

RA8M1 Group

Evaluation Kit for RA8M1 Microcontroller Group
EK-RA8M1 v1
User's Manual

Renesas RA Family
RA8 Series

All information contained in these materials, including products and product specifications, represents information on the product at the time of publication and is subject to change by Renesas Electronics Corp. without notice. Please review the latest information published by Renesas Electronics Corp. through various means, including the Renesas Electronics Corp. website (<https://www.renesas.com>).

Notice

1. Descriptions of circuits, software and other related information in this document are provided only to illustrate the operation of semiconductor products and application examples. You are fully responsible for the incorporation or any other use of the circuits, software, and information in the design of your product or system. Renesas Electronics disclaims any and all liability for any losses and damages incurred by you or third parties arising from the use of these circuits, software, or information.
2. Renesas Electronics hereby expressly disclaims any warranties against and liability for infringement or any other claims involving patents, copyrights, or other intellectual property rights of third parties, by or arising from the use of Renesas Electronics products or technical information described in this document, including but not limited to, the product data, drawings, charts, programs, algorithms, and application examples.
3. No license, express, implied or otherwise, is granted hereby under any patents, copyrights or other intellectual property rights of Renesas Electronics or others.
4. You shall be responsible for determining what licenses are required from any third parties, and obtaining such licenses for the lawful import, export, manufacture, sales, utilization, distribution or other disposal of any products incorporating Renesas Electronics products, if required.
5. You shall not alter, modify, copy, or reverse engineer any Renesas Electronics product, whether in whole or in part. Renesas Electronics disclaims any and all liability for any losses or damages incurred by you or third parties arising from such alteration, modification, copying or reverse engineering.
6. Renesas Electronics products are classified according to the following two quality grades: "Standard" and "High Quality". The intended applications for each Renesas Electronics product depends on the product's quality grade, as indicated below.

"Standard": Computers; office equipment; communications equipment; test and measurement equipment; audio and visual equipment; home electronic appliances; machine tools; personal electronic equipment; industrial robots; etc.

"High Quality": Transportation equipment (automobiles, trains, ships, etc.); traffic control (traffic lights); large-scale communication equipment; key financial terminal systems; safety control equipment; etc.

Unless expressly designated as a high reliability product or a product for harsh environments in a Renesas Electronics data sheet or other Renesas Electronics document, Renesas Electronics products are not intended or authorized for use in products or systems that may pose a direct threat to human life or bodily injury (artificial life support devices or systems; surgical implantations; etc.), or may cause serious property damage (space system; undersea repeaters; nuclear power control systems; aircraft control systems; key plant systems; military equipment; etc.). Renesas Electronics disclaims any and all liability for any damages or losses incurred by you or any third parties arising from the use of any Renesas Electronics product that is inconsistent with any Renesas Electronics data sheet, user's manual or other Renesas Electronics document.
7. No semiconductor product is absolutely secure. Notwithstanding any security measures or features that may be implemented in Renesas Electronics hardware or software products, Renesas Electronics shall have absolutely no liability arising out of any vulnerability or security breach, including but not limited to any unauthorized access to or use of a Renesas Electronics product or a system that uses a Renesas Electronics product. RENESAS ELECTRONICS DOES NOT WARRANT OR GUARANTEE THAT RENESAS ELECTRONICS PRODUCTS, OR ANY SYSTEMS CREATED USING RENESAS ELECTRONICS PRODUCTS WILL BE INVULNERABLE OR FREE FROM CORRUPTION, ATTACK, VIRUSES, INTERFERENCE, HACKING, DATA LOSS OR THEFT, OR OTHER SECURITY INTRUSION ("Vulnerability Issues"). RENESAS ELECTRONICS DISCLAIMS ANY AND ALL RESPONSIBILITY OR LIABILITY ARISING FROM OR RELATED TO ANY VULNERABILITY ISSUES. FURTHERMORE, TO THE EXTENT PERMITTED BY APPLICABLE LAW, RENESAS ELECTRONICS DISCLAIMS ANY AND ALL WARRANTIES, EXPRESS OR IMPLIED, WITH RESPECT TO THIS DOCUMENT AND ANY RELATED OR ACCOMPANYING SOFTWARE OR HARDWARE, INCLUDING BUT NOT LIMITED TO THE IMPLIED WARRANTIES OF MERCHANTABILITY, OR FITNESS FOR A PARTICULAR PURPOSE.
8. When using Renesas Electronics products, refer to the latest product information (data sheets, user's manuals, application notes, "General Notes for Handling and Using Semiconductor Devices" in the reliability handbook, etc.), and ensure that usage conditions are within the ranges specified by Renesas Electronics with respect to maximum ratings, operating power supply voltage range, heat dissipation characteristics, installation, etc. Renesas Electronics disclaims any and all liability for any malfunctions, failure or accident arising out of the use of Renesas Electronics products outside of such specified ranges.
9. Although Renesas Electronics endeavors to improve the quality and reliability of Renesas Electronics products, semiconductor products have specific characteristics, such as the occurrence of failure at a certain rate and malfunctions under certain use conditions. Unless designated as a high reliability product or a product for harsh environments in a Renesas Electronics data sheet or other Renesas Electronics document, Renesas Electronics products are not subject to radiation resistance design. You are responsible for implementing safety measures to guard against the possibility of bodily injury, injury or damage caused by fire, and/or danger to the public in the event of a failure or malfunction of Renesas Electronics products, such as safety design for hardware and software, including but not limited to redundancy, fire control and malfunction prevention, appropriate treatment for aging degradation or any other appropriate measures. Because the evaluation of microcomputer software alone is very difficult and impractical, you are responsible for evaluating the safety of the final products or systems manufactured by you.
10. Please contact a Renesas Electronics sales office for details as to environmental matters such as the environmental compatibility of each Renesas Electronics product. You are responsible for carefully and sufficiently investigating applicable laws and regulations that regulate the inclusion or use of controlled substances, including without limitation, the EU RoHS Directive, and using Renesas Electronics products in compliance with all these applicable laws and regulations. Renesas Electronics disclaims any and all liability for damages or losses occurring as a result of your noncompliance with applicable laws and regulations.
11. Renesas Electronics products and technologies shall not be used for or incorporated into any products or systems whose manufacture, use, or sale is prohibited under any applicable domestic or foreign laws or regulations. You shall comply with any applicable export control laws and regulations promulgated and administered by the governments of any countries asserting jurisdiction over the parties or transactions.
12. It is the responsibility of the buyer or distributor of Renesas Electronics products, or any other party who distributes, disposes of, or otherwise sells or transfers the product to a third party, to notify such third party in advance of the contents and conditions set forth in this document.
13. This document shall not be reprinted, reproduced or duplicated in any form, in whole or in part, without prior written consent of Renesas Electronics.
14. Please contact a Renesas Electronics sales office if you have any questions regarding the information contained in this document or Renesas Electronics products.

(Note1) "Renesas Electronics" as used in this document means Renesas Electronics Corporation and also includes its directly or indirectly controlled subsidiaries.

(Note2) "Renesas Electronics product(s)" means any product developed or manufactured by or for Renesas Electronics.

(Rev.5.0-1 October 2020)

Corporate Headquarters

TOYOSU FORESIA, 3-2-24 Toyosu,
Koto-ku, Tokyo 135-0061, Japan
www.renesas.com

Trademarks

Renesas and the Renesas logo are trademarks of Renesas Electronics Corporation. All trademarks and registered trademarks are the property of their respective owners.

Contact information

For further information on a product, technology, the most up-to-date version of a document, or your nearest sales office, please visit:
www.renesas.com/contact/

General Precautions in the Handling of Microprocessing Unit and Microcontroller Unit Products

The following usage notes are applicable to all Microprocessing unit and Microcontroller unit products from Renesas. For detailed usage notes on the products covered by this document, refer to the relevant sections of the document as well as any technical updates that have been issued for the products.

1. Precaution against Electrostatic Discharge (ESD)

A strong electrical field, when exposed to a CMOS device, can cause destruction of the gate oxide and ultimately degrade the device operation. Steps must be taken to stop the generation of static electricity as much as possible, and quickly dissipate it when it occurs. Environmental control must be adequate. When it is dry, a humidifier should be used. This is recommended to avoid using insulators that can easily build up static electricity. Semiconductor devices must be stored and transported in an anti-static container, static shielding bag or conductive material. All test and measurement tools including work benches and floors must be grounded. The operator must also be grounded using a wrist strap. Semiconductor devices must not be touched with bare hands. Similar precautions must be taken for printed circuit boards with mounted semiconductor devices.

2. Processing at power-on

The state of the product is undefined at the time when power is supplied. The states of internal circuits in the LSI are indeterminate and the states of register settings and pins are undefined at the time when power is supplied. In a finished product where the reset signal is applied to the external reset pin, the states of pins are not guaranteed from the time when power is supplied until the reset process is completed. In a similar way, the states of pins in a product that is reset by an on-chip power-on reset function are not guaranteed from the time when power is supplied until the power reaches the level at which resetting is specified.

3. Input of signal during power-off state

Do not input signals or an I/O pull-up power supply while the device is powered off. The current injection that results from input of such a signal or I/O pull-up power supply may cause malfunction and the abnormal current that passes in the device at this time may cause degradation of internal elements. Follow the guideline for input signal during power-off state as described in your product documentation.

4. Handling of unused pins

Handle unused pins in accordance with the directions given under handling of unused pins in the manual. The input pins of CMOS products are generally in the high-impedance state. In operation with an unused pin in the open-circuit state, extra electromagnetic noise is induced in the vicinity of the LSI, an associated shoot-through current flows internally, and malfunctions occur due to the false recognition of the pin state as an input signal become possible.

5. Clock signals

After applying a reset, only release the reset line after the operating clock signal becomes stable. When switching the clock signal during program execution, wait until the target clock signal is stabilized. When the clock signal is generated with an external resonator or from an external oscillator during a reset, ensure that the reset line is only released after full stabilization of the clock signal. Additionally, when switching to a clock signal produced with an external resonator or by an external oscillator while program execution is in progress, wait until the target clock signal is stable.

6. Voltage application waveform at input pin

Waveform distortion due to input noise or a reflected wave may cause malfunction. If the input of the CMOS device stays in the area between V_{IL} (Max.) and V_{IH} (Min.) due to noise, for example, the device may malfunction. Take care to prevent chattering noise from entering the device when the input level is fixed, and also in the transition period when the input level passes through the area between V_{IL} (Max.) and V_{IH} (Min.).

7. Prohibition of access to reserved addresses

Access to reserved addresses is prohibited. The reserved addresses are provided for possible future expansion of functions. Do not access these addresses as the correct operation of the LSI is not guaranteed.

8. Differences between products

Before changing from one product to another, for example to a product with a different part number, confirm that the change will not lead to problems. The characteristics of a microprocessing unit or microcontroller unit products in the same group but having a different part number might differ in terms of internal memory capacity, layout pattern, and other factors, which can affect the ranges of electrical characteristics, such as characteristic values, operating margins, immunity to noise, and amount of radiated noise. When changing to a product with a different part number, implement a system-evaluation test for the given product.

Renesas EK-RA8M1 Disclaimer

By using this EK-RA8M1, the User accepts the following terms, which are in addition to, and control in the event of disagreement, with Renesas' General Terms and Conditions available at [renesas.com/legal-notices](https://www.renesas.com/legal-notices).

The EK-RA8M1 is not guaranteed to be error free, and the entire risk as to the results and performance of the EK-RA8M1 is assumed by the User. The EK-RA8M1 is provided by Renesas on an "as is" basis without warranty of any kind whether express or implied, including but not limited to the implied warranties of good workmanship, fitness for a particular purpose, title, merchantability, and non-infringement of intellectual property rights. Renesas expressly disclaims any implied warranty.

Renesas does not consider the EK-RA8M1 to be a finished product and therefore the EK-RA8M1 may not comply with some requirements applicable to finished products, including, but not limited to recycling, restricted substances and electromagnetic compatibility regulations. Refer to Certifications section, for information about certifications and compliance information for the EK-RA8M1. It is the kit User's responsibility to make sure the kit meets any local requirements applicable to their region.

Renesas or its affiliates shall in no event be liable for any loss of profit, loss of data, loss of contract, loss of business, damage to reputation or goodwill, any economic loss, any reprogramming or recall costs (whether the foregoing losses are direct or indirect) nor shall Renesas or its affiliates be liable for any other direct or indirect special, incidental or consequential damages arising out of or in relation to the use of this EK-RA8M1, even if Renesas or its affiliates have been advised of the possibility of such damages.

Renesas has used reasonable care in preparing the information included in this document, but Renesas does not warrant that such information is error free nor does Renesas guarantee an exact match for every application or parameter to part numbers designated by other vendors listed herein. The information provided in this document is intended solely to enable the use of Renesas products. No express or implied license to any intellectual property right is granted by this document or in connection with the sale of Renesas products. Renesas reserves the right to make changes to specifications and product descriptions at any time without notice. Renesas assumes no liability for any damages incurred by you resulting from errors in or omissions from the information included herein. Renesas cannot verify, and assumes no liability for, the accuracy of information available on another company's website.

Precautions

This Evaluation Kit is only intended for use in a laboratory environment under ambient temperature and humidity conditions. A safe separation distance should be used between this and any sensitive equipment. Its use outside the laboratory, classroom, study area, or similar such area invalidates conformity with the protection requirements of the Electromagnetic Compatibility Directive and could lead to prosecution.

The product generates, uses, and can radiate radio frequency energy and may cause harmful interference to radio communications. There is no guarantee that interference will not occur in a particular installation. If this equipment causes harmful interference to radio or television reception, which can be determined by turning the equipment off or on, you are encouraged to try to correct the interference by one or more of the following measures:

- Ensure attached cables do not lie across the equipment.
- Reorient the receiving antenna.
- Increase the distance between the equipment and the receiver.
- Connect the equipment into an outlet on a circuit different from that which the receiver is connected.
- Power down the equipment when not in use.
- Consult the dealer or an experienced radio/TV technician for help.

Note: It is recommended that wherever possible shielded interface cables are used.

The product is potentially susceptible to certain EMC phenomena. To mitigate against them it is recommended that the following measures be undertaken:

- The user is advised that mobile phones should not be used within 10 m of the product when in use.
- The user is advised to take ESD precautions when handling the equipment.

The Evaluation Kit does not represent an ideal reference design for an end product and does not fulfill the regulatory standards for an end product.

Renesas RA Family

EK-RA8M1 v1
Contents

1. Kit Overview.....	5
1.1 Assumptions and Advisory Notes.....	8
2. Kit Contents	9
3. Ordering Information.....	9
4. Hardware Architecture and Default Configuration	10
4.1 Kit Architecture	10
4.2 System Block Diagram	12
4.3 Jumper Configuration	13
4.3.1 Copper Jumpers.....	13
4.3.2 Traditional Pin Header Jumpers.....	13
4.3.3 Default Jumper Configuration.....	14
5. System Control and Ecosystem Access Area	16
5.1 Power	17
5.1.1 Power Supply Options.....	17
5.1.2 Power Supply Considerations	18
5.1.3 Power-up Behavior.....	18
5.2 Debug and Trace.....	18
5.2.1 Debug On-Board	19
5.2.2 Debug In.....	20
5.2.3 Debug Out.....	21
5.3 Ecosystem.....	21
5.3.1 Seeed Grove® Connectors	21
5.3.2 SparkFun Qwiic® Connector.....	22
5.3.3 Digilent Pmod™ Connectors.....	22
5.3.4 Arduino™ Connector	24
5.3.5 MikroElektronika mikroBUS™ Connector.....	26
5.4 Connectivity.....	27
5.4.1 USB Full Speed.....	27
5.4.2 I3C.....	28
5.5 Miscellaneous.....	28
5.5.1 User and Power LEDs.....	28
5.5.2 User and Reset Switches	29
5.5.3 MCU Boot Mode.....	29

5.5.4	Crystals	29
6.	Special Feature Access Area	31
6.1	CAN FD Bus	31
6.2	Ethernet	32
6.3	USB High Speed	33
6.4	Octo-SPI Flash	34
7.	MCU Native Pin Access Area	35
7.1	Breakout Pin Headers	35
7.2	MCU and USB Current Measurement	36
8.	Certifications	37
8.1	EMC/EMI Standards	37
8.2	Material Selection, Waste, Recycling and Disposal Standards	37
8.3	Safety Standards	38
9.	Design and Manufacturing Information	39
10.	Website and Support	39
	Revision History	40

Figures

Figure 1.	EK-RA8M1 Board Top Side	6
Figure 2.	EK-RA8M1 Board Bottom Side	7
Figure 3.	EK-RA8M1 Kit Contents	9
Figure 4.	EK-RA8M1 Board Functional Area Definitions	11
Figure 5.	EK-RA8M1 Board Block Diagram	12
Figure 6.	Copper Jumpers	13
Figure 7.	System Control and Ecosystem Access Area	16
Figure 8.	Power Supply Options	17
Figure 9.	Test Point Location	18
Figure 10.	EK-RA8M1 Debug Interface	19
Figure 11.	Seeed Grove® and SparkFun Qwiic® Connector Footprints	22
Figure 12.	Pmod 1 Connector	23
Figure 13.	Pmod 2 Connector	24
Figure 14.	Arduino Uno Connectors	25
Figure 15.	mikroBUS™ Connection	26
Figure 16.	USB Full Speed Connector	27
Figure 17.	User LEDs	28
Figure 18.	Power LED	29
Figure 19.	Reset and User Switches	29

Figure 20. Boot Mode	29
Figure 21. Special Feature Access Area	31
Figure 22. CAN FD Bus	31
Figure 23. Ethernet Connector	32
Figure 24. USB High Speed Connector	33
Figure 25. Octo-SPI Flash	34
Figure 26. Native Pin Access Area	35
Figure 27. RA USB Current Measurement Circuit	36
Figure 28. RA +3.3 V Current Measurement Circuit	36
Figure 29. RA MCU and USB Current Measurement	36

Tables

Table 1. Kit Architecture	10
Table 2. Default Jumper Configuration	14
Table 3. Debug Modes	18
Table 4. Jumper Connection Summary for Different Debug Modes	19
Table 5. Debug USB Port Assignments	19
Table 6. Debug On-Board Jumper Configuration	19
Table 7. Debug In Mode Jumper Configuration	20
Table 8. JTAG/SWO/SWD/ETM Debug Port Assignments	20
Table 9. JTAG/SWO/SWD Debug Port Assignments	20
Table 10. Debug Out Jumper Configuration	21
Table 11. Grove 1 Port Assignments	21
Table 12. Grove 2 Port Assignments	22
Table 13. Qwiic [®] Port Assignments	22
Table 14. Pmod 1 Port Assignments	23
Table 15. Pmod 2 Port Assignments	24
Table 16. Arduino Uno Port Assignments	24
Table 17. mikroBUS [™] Assignments	26
Table 18. USB Full Speed Port Assignments	27
Table 19. I ² C/I ³ C Pullup Configuration	28
Table 20. EK-RA8M1 Board LED Functions	28
Table 21. EK-RA8M1 Board Switches	29
Table 22. Main 20 MHz Crystal Configuration	30
Table 23. CAN FD bus connections between U21 and RA8M1	31
Table 24. CAN FD Port Assignments	31
Table 25. Ethernet Port Assignments	32
Table 26. Ethernet Components	32
Table 27. USB High Speed Port Assignments	33
Table 28. Octo-SPI Flash Port Assignments	34

Table 29. EK-RA8M1 Board Design Package Contents39

1. Kit Overview

The EK-RA8M1, an Evaluation Kit for RA8M1 MCU Group, enables users to seamlessly evaluate the features of the RA8M1 MCU group and develop embedded systems applications using Flexible Software Package (FSP) and e² studio IDE. The users can utilize rich on-board features along with their choice of popular ecosystems add-ons to bring their big ideas to life.

The key features of the EK-RA8M1 board are categorized in three groups (consistent with the architecture of the kit, with one exception) as follows:

MCU Native Pin Access

- R7FA8M1AHECBD MCU (referred to as RA MCU)
- 480 MHz, Arm[®] Cortex[®]-M85 core
- 2 MB Code Flash, 1 MB SRAM
- 224 pins, BGA package
- Native pin access through 2 x 50-pin, and 2 x 40-pin male headers
- MCU current measurement points for precision current consumption measurement
- Multiple clock sources - RA MCU oscillator and sub-clock oscillator crystals, providing precision 20.000 MHz and 32,768 Hz reference clocks. Additional low-precision clocks are available internal to the RA MCU

System Control and Ecosystem Access

- USB Full Speed Host and Device (micro-AB connector)
- Four 5 V input sources
 - USB (Debug, Full Speed, High Speed)
 - External power supply (using surface mount clamp test points and power input vias)
- Three Debug modes
 - Debug on-board (SWD and JTAG)
 - Debug in (ETM, SWD, SWO and JTAG)
 - Debug out (SWD, SWO and JTAG)
- User LEDs and buttons
 - Three User LEDs (red, blue, green)
 - Power LED (white) indicating availability of regulated power
 - Debug LED (yellow) indicating the debug connection
 - Two User buttons
 - One Reset button
- Five most popular ecosystems expansions
 - Two Seeed Grove[®] system (I²C/I³C) connectors (not populated)
 - One SparkFun Qwiic[®] connector (not populated)
 - Two Digilent Pmod[™] (SPI, UART and I²C/I³C) connectors
 - Arduino[™] (Uno R3 / R4) connector
 - MikroElektronika mikroBUS[™] connector
- MCU boot configuration jumper

Special Feature Access

- Ethernet (RJ45 RMII interface)
- USB High Speed Host and Device (micro-AB connector)
- 512 Mb (64 MB) External Octo-SPI Flash (present in the MCU Native Pin Access area of the EK-RA8M1 board)
- CAN FD (3-pin header)

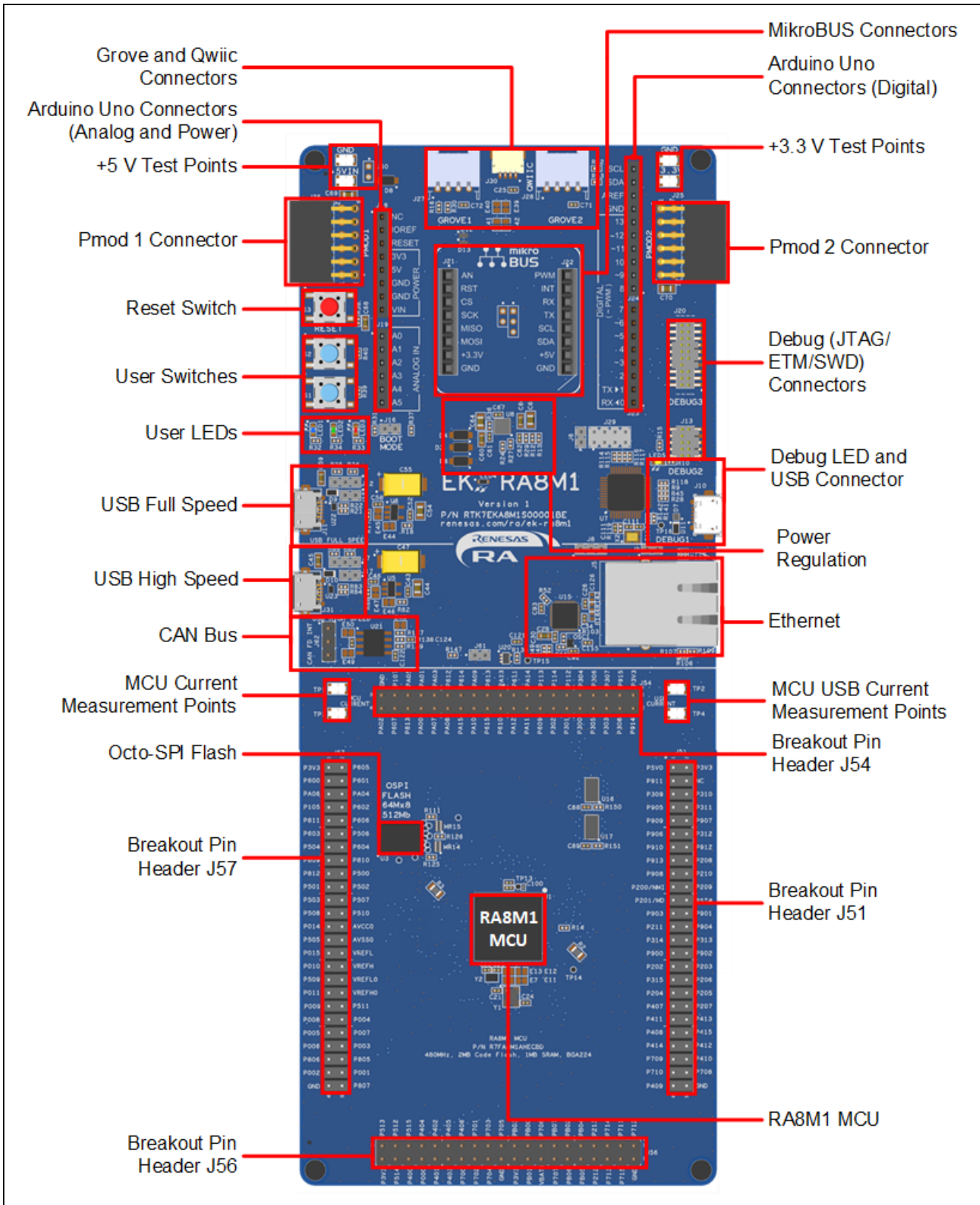

Figure 1. EK-RA8M1 Board Top Side

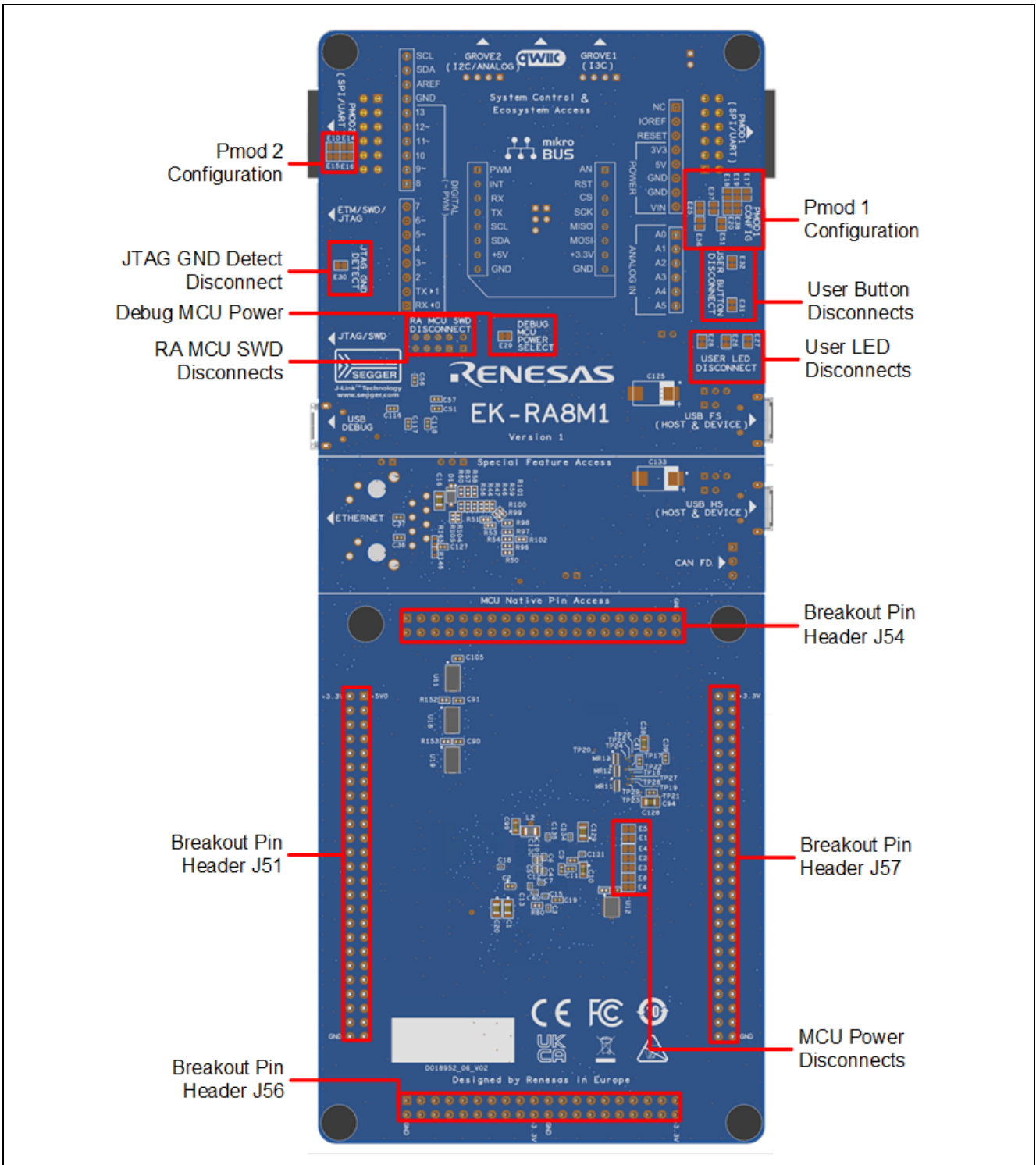

Figure 2. EK-RA8M1 Board Bottom Side

1.1 Assumptions and Advisory Notes

1. It is assumed that the user has a basic understanding of microcontrollers and embedded systems hardware.
2. It is recommended that the user refers to the *EK-RA8M1 Quick Start Guide* to get acquainted with the kit and the Quick Start example project that EK-RA8M1 board comes pre-programmed with.
3. Flexible Software Package (FSP) and Integrated Development Environment (IDE) such as e² studio are required to develop embedded applications on EK-RA8M1 kit.
4. Instructions to download and install software, import example projects, build them and program the EK-RA8M1 board are provided in the quick start guide.
5. The MCU fitted to the EK board may not contain the latest version of the on-chip boot firmware.

2. Kit Contents

The following components are included in the kit:

1. EK-RA8M1 v1 board
2. Micro USB device cable (type-A male to micro-B male)
3. Micro USB host cable (type-A female to micro-B male)
4. Ethernet patch cable

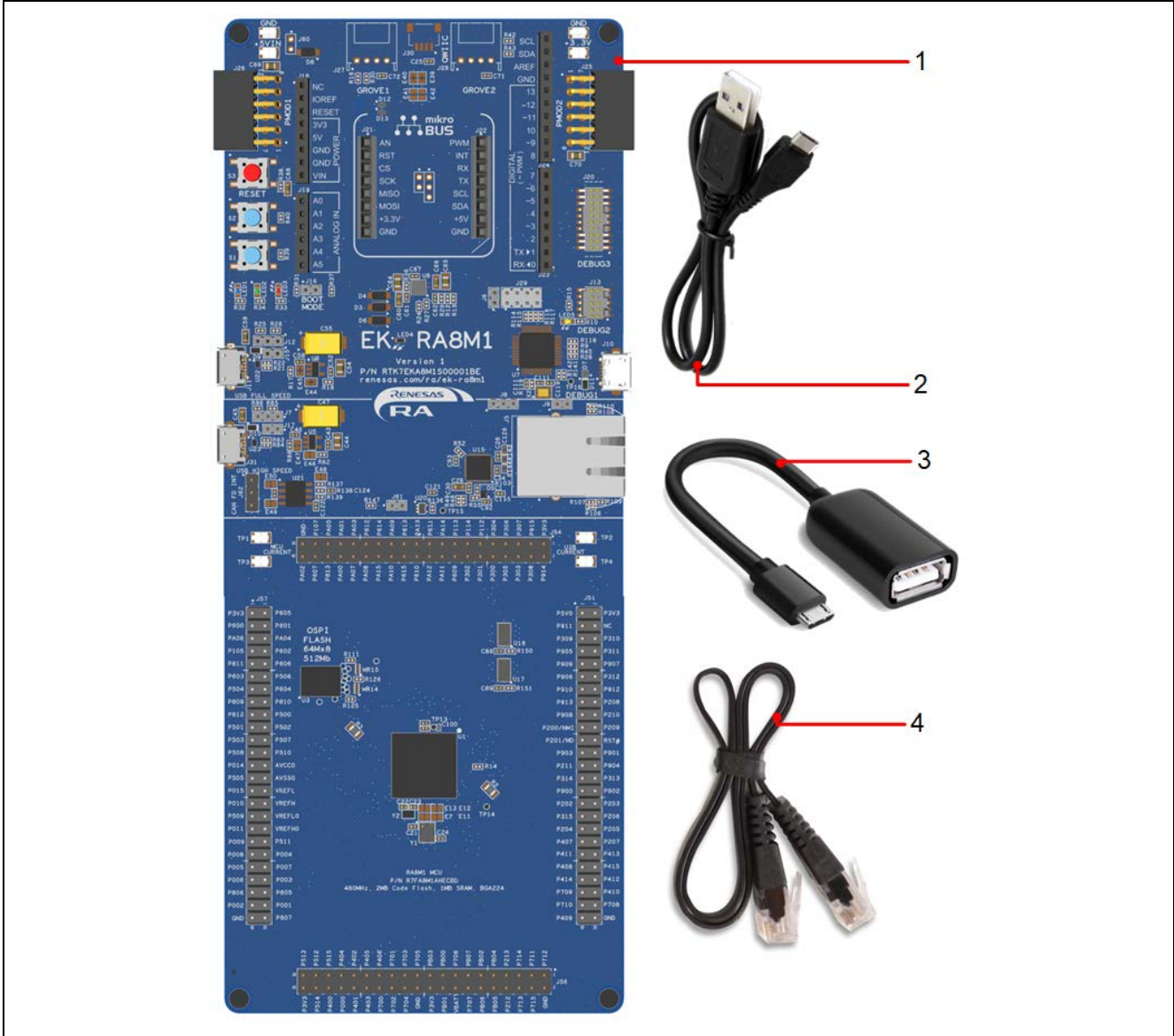

Figure 3. EK-RA8M1 Kit Contents

3. Ordering Information

- EK-RA8M1 v1 kit orderable part number: RTK7EKA8M1S00001BE

Note: The underlined character in the orderable part number represents the kit version

- EK-RA8M1 board dimensions: 80 mm (width) x 200 mm (length)

4. Hardware Architecture and Default Configuration

4.1 Kit Architecture

The EK-RA8M1 board is designed with three sections or areas to help shorten the learning curve of the users and maximize the design and knowledge reuse among similar kits. The contents of these three areas are conceptually standardized among similar kits.

Table 1. Kit Architecture

Kit area	Area features	Area present on all similar kits	Functionality is:
MCU Native Pin Access Area	RA MCU, breakout pin headers for all MCU I/O and power, current measurement, and Octo-SPI Flash	Yes	MCU dependent
Special Feature Access Area	MCU special features: Ethernet, USB High Speed Host and Device, and CAN FD	Optional	MCU dependent
System Control and Ecosystem Access Area	Power, Debug MCU, User LED and buttons, reset, ecosystem connectors, USB Full Speed Host and Device, and Boot configuration	Yes	Same or similar across similar kits

Note: The Octo-SPI Flash is among the Special Feature Access features. Normally, it would be in Special Feature Access Area, however, to optimize the layout, routing, and performance, it is placed in the MCU Native Pin Access area.

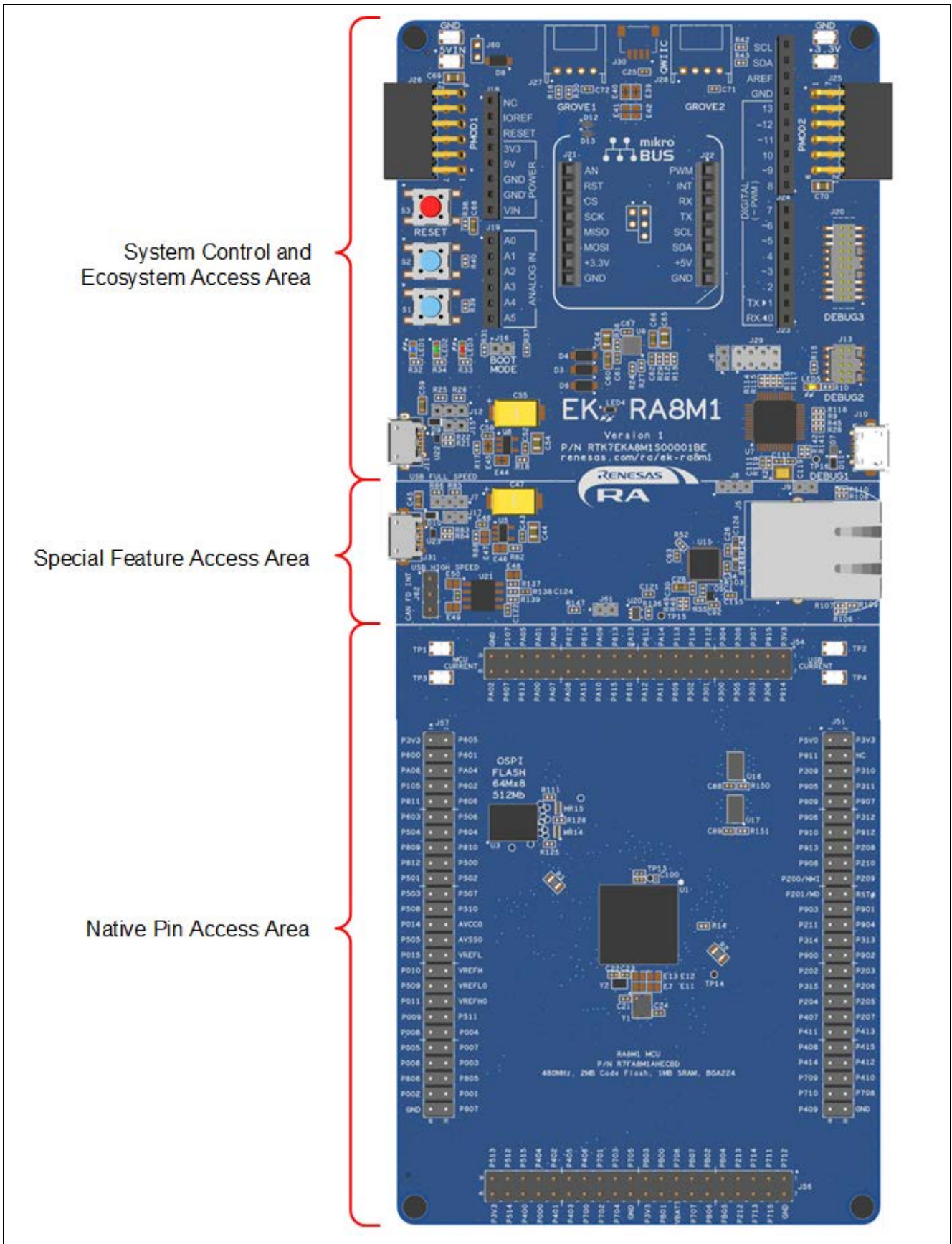

Figure 4. EK-RA8M1 Board Functional Area Definitions

4.2 System Block Diagram

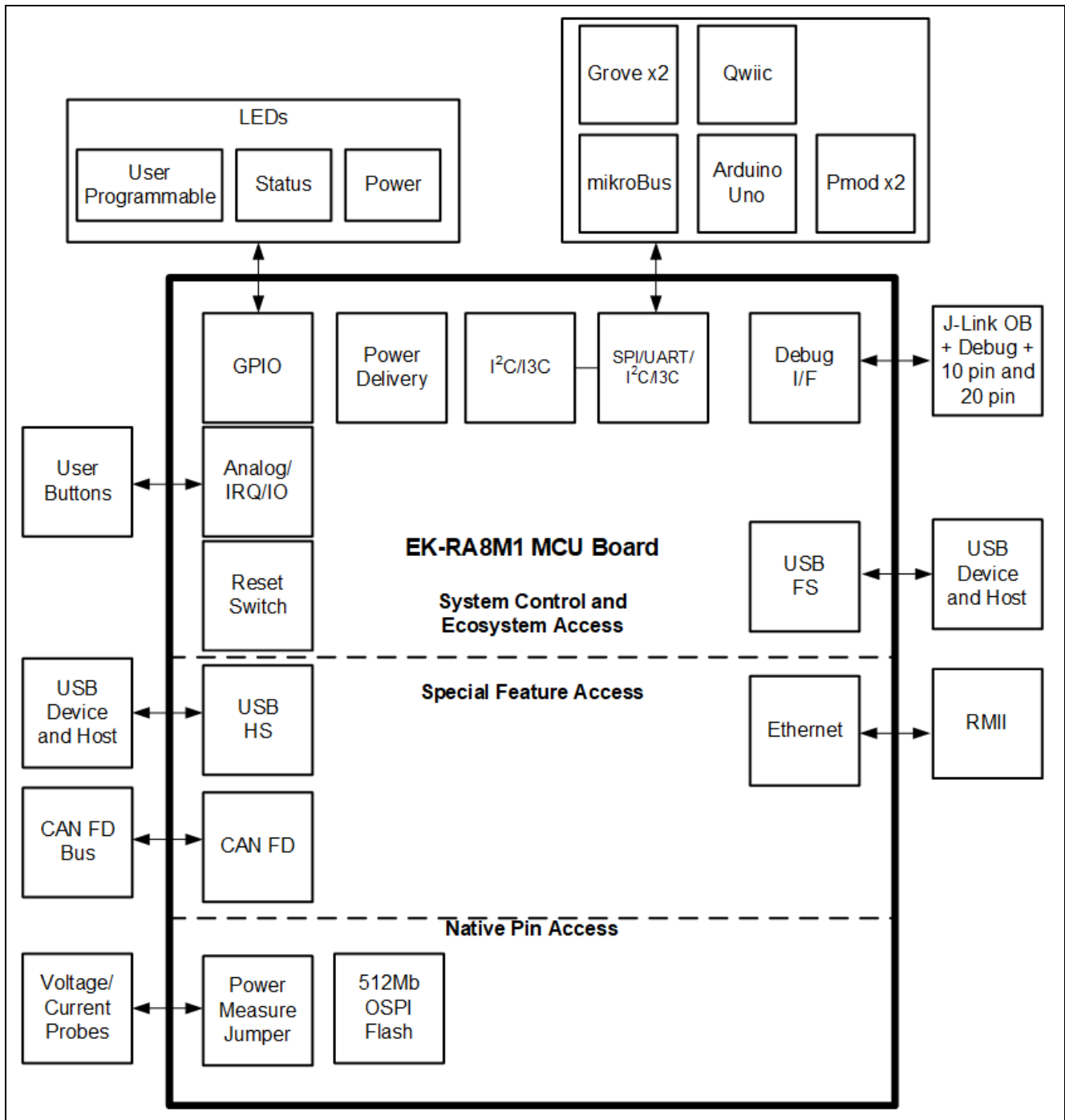

Figure 5. EK-RA8M1 Board Block Diagram

4.3 Jumper Configuration

Two types of jumpers are provided on the EK-RA8M1 board.

1. Copper jumpers (trace-cut type and solder bridge type)
2. Traditional pin header jumpers

The following sections describe each type and their default configuration.

4.3.1 Copper Jumpers

Copper jumpers are of two types, designated **trace-cut** and **solder-bridge**.

A **trace-cut jumper** is provided with a narrow copper trace connecting its pads. The silk screen overlay printing around a trace-cut jumper is a solid box. To isolate the pads, cut the trace between pads adjacent to each pad, then remove the connecting copper foil either mechanically or with the assistance of heat. Once the etched copper trace is removed, the trace-cut jumper is turned into a solder-bridge jumper for any later changes.

A **solder-bridge** jumper is provided with two isolated pads that may be joined together by one of three methods:

- Solder may be applied to both pads to develop a bulge on each and the bulges joined by touching a soldering iron across the two pads.
- A small wire may be placed across the two pads and soldered in place.
- A SMT resistor, size 0805, 0603 or 0402, may be placed across the two pads and soldered in place. A zero-ohm resistor shorts the pads together.

For any copper jumper, the connection is considered **closed** if there is an electrical connection between the pads (default for trace-cut jumpers). The connection is considered **open** if there is no electrical connection between the pads (default for the solder-bridge jumpers.)

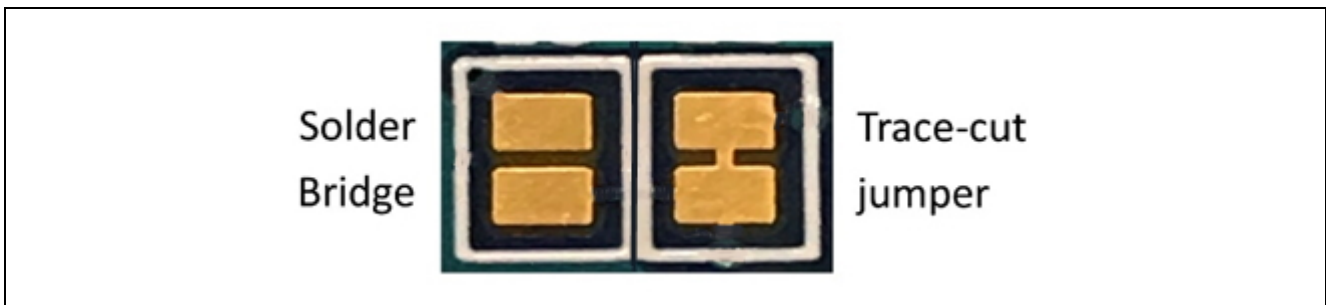

Figure 6. Copper Jumpers

4.3.2 Traditional Pin Header Jumpers

These jumpers are traditional small pitch jumpers that require an external shunt to open/close them. The traditional pin jumpers on the EK-RA8M1 board are 2 mm pitch headers and require compatible 2 mm shunt jumpers.

4.3.3 Default Jumper Configuration

The following table describes the default configuration for each jumper on the EK-RA8M1 board. This includes copper jumpers (Ex designation) and traditional pin jumpers (Jx designation).

The Circuit Group for each jumper is the designation found in the board schematic (available in the Design Package). Functional details for many of the listed jumpers may be found in sections associated with each functional area of the kits.

Table 2. Default Jumper Configuration

Location	Circuit Group	Default Open/Closed	Function
J6	J-Link OB	Open	Configures J-Link OB connection to MCU mode
J8	J-Link OB	Jumper on pins 1-2	Configures the MCU for normal operation
J9	J-Link OB	Open	Configures JLOB_RESET# for on-board debugger mode
J29	J-Link OB	Jumper on pins 1-2 Jumper on pins 3-4 Jumper on pins 5-6 Jumper on pins 7-8	Connects the J-Link OB debugger to the RA MCU
J16	MCU Boot Mode	Open	Configures the MCU for normal boot mode
J12	USB FS	Jumper on pins 2-3	Sets USB FS power to device mode
J15	USB FS	Closed	Connects micro-USB power to system power
J7	USB HS	Jumper on pins 2-3	Sets USB HS power to device mode
J17	USB HS	Closed	Connects micro-USB power to system power
J61	I3C	Closed	Connects P400 and P401 to Arduino/MikroBUS™/Grove1/qwiic® connector. Note: To enable pull-up, set PB00/P711 to push-pull output drive high.
E1	MCU Power	Closed	Connects VREFL0 to GND
E2	MCU Power	Closed	Connects VREFH to +3.3 V
E3	MCU Power	Closed	Connects AVCC0 to +3.3 V
E4	MCU Power	Closed	Connects AVSS0 to GND
E5	MCU Power	Closed	Connects VREFL to GND
E6	MCU Power	Closed	Connects VREFH0 to +3.3 V
E7	MCU Clock	Closed	Connects P212/EXTAL to 20 MHz crystal
E11	MCU Clock	Closed	Connects P213/XTAL to 20 MHz crystal
E12	MCU Clock	Open	Connects P213/XTAL pin to pin headers
E13	MCU Clock	Open	Connects P212/EXTAL pin to pin headers
E10	Pmod2	Open	Connects PA06 (CTS2) to Pmod 2 pin 1
E14	Pmod2	Open	Connects PA05 (RTS2) to Pmod 2 pin 4
E15	Pmod2	Closed	Connects PA05 (SSL2) to Pmod 2 pin 1
E16	Pmod2	Closed	Connects PA04 (SCK2) to Pmod 2 pin 4
E17	Pmod1	Open	Connects P613 (CTS0) to Pmod 1 pin 1
E18	Pmod1	Open	Connects P612 (RTS0) to Pmod 1 pin 4
E19	Pmod1	Closed	Connects P612 (SSL0) to Pmod 1 pin 1
E20	Pmod1	Closed	Connects P611 (SCK0) to Pmod 1 pin 4
E25	Pmod1	Closed	Connects +3.3 V to Pmod 1
E36	Pmod1	Open	Connects +5.0 V to Pmod 1
E37	Pmod1	Open	Connects P400 (I3C_SCL0) to Pmod 1 pin 3
E38	Pmod1	Open	Connects P401 (I3C_SDA0) to Pmod 1 pin 4
E51	Pmod1	Closed	Connects P610 (MISO0/RXD0) to Pmod 1 pin 3
E26	User LED	Closed	Connects P414 to User LED2
E27	User LED	Closed	Connects P600 to User LED1
E28	User LED	Closed	Connects P107 to User LED3

Location	Circuit Group	Default Open/Closed	Function
E29	Debug MCU Power	Closed	Connects the Debug MCU power to +3.3 V
E30	JTAG	Closed	Connects the JTAG GND Detect pin on J20 and J13 to GND
E31	User Switch	Closed	Connects P009 to User Switch S1
E32	User Switch	Closed	Connects P008 to User Switch S2
E39	Grove 2	Closed	Connects P512 (I ² C/SCL1) to Grove 2
E40	Grove 2	Closed	Connects P511 (I ² C/SDA1) to Grove 2
E41	Grove 2	Open	Connects P002 (AN102) to Grove 2
E42	Grove 2	Open	Connects P005 (AN001) to Grove 2
E43	Arduino	Closed	Connects VREFH to the Arduino AREF pin
E44	USBFS	Closed	Connects P500 to the VBUS power supply enable pin for USB Full Speed
E45	USBFS	Closed	Connects P501 to the USB VBUS Fault signal for USB Full Speed
E46	USBHS	Closed	Connects P408 to the VBUS power supply enable pin for USB High Speed
E47	USBHS	Closed	Connects P409 to the USB OVRCURA for USB High Speed
E48	CAN FD	Closed	Connects P207 STB to CAN-FD Interface
E49	CAN FD	Closed	Connects P311 RXD to CAN-FD Interface
E50	CAN FD	Closed	Connects P312 TXD to CAN-FD Interface

5. System Control and Ecosystem Access Area

The following figure shows the System Control and Ecosystem Access area on the EK-RA8M1 board. Subsequent sections detail the features and functionality provided in the area.

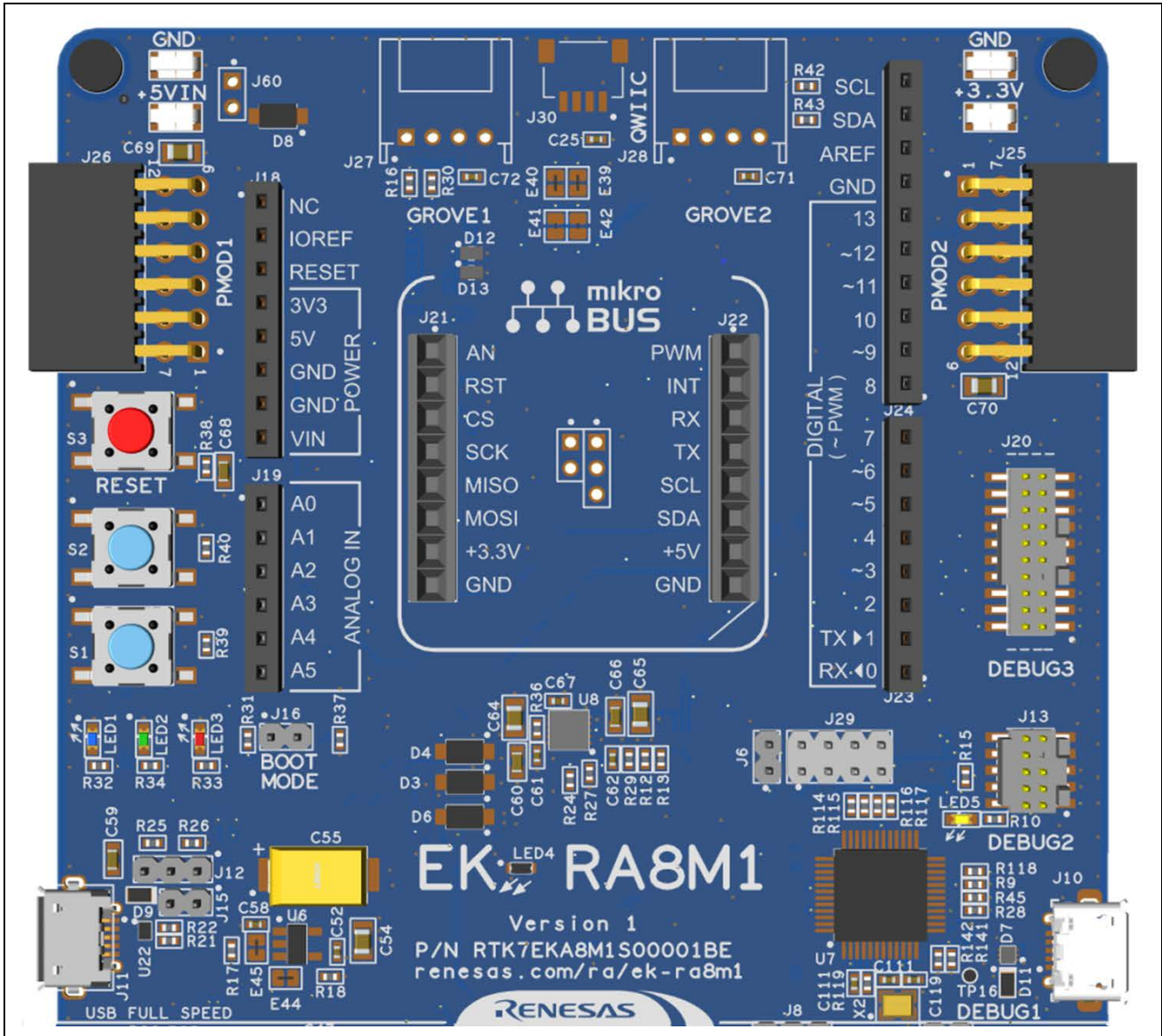

Figure 7. System Control and Ecosystem Access Area

5.1 Power

The EK-RA8M1 kit is designed for +5 V operation. An on-board Low Dropout Regulator (LDO) is used to convert the 5 V supply to a 3.3 V supply. The 3.3 V supply is used to power the RA MCU and other peripheral features.

5.1.1 Power Supply Options

This section describes the different ways in which EK-RA8M1 kit can be powered.

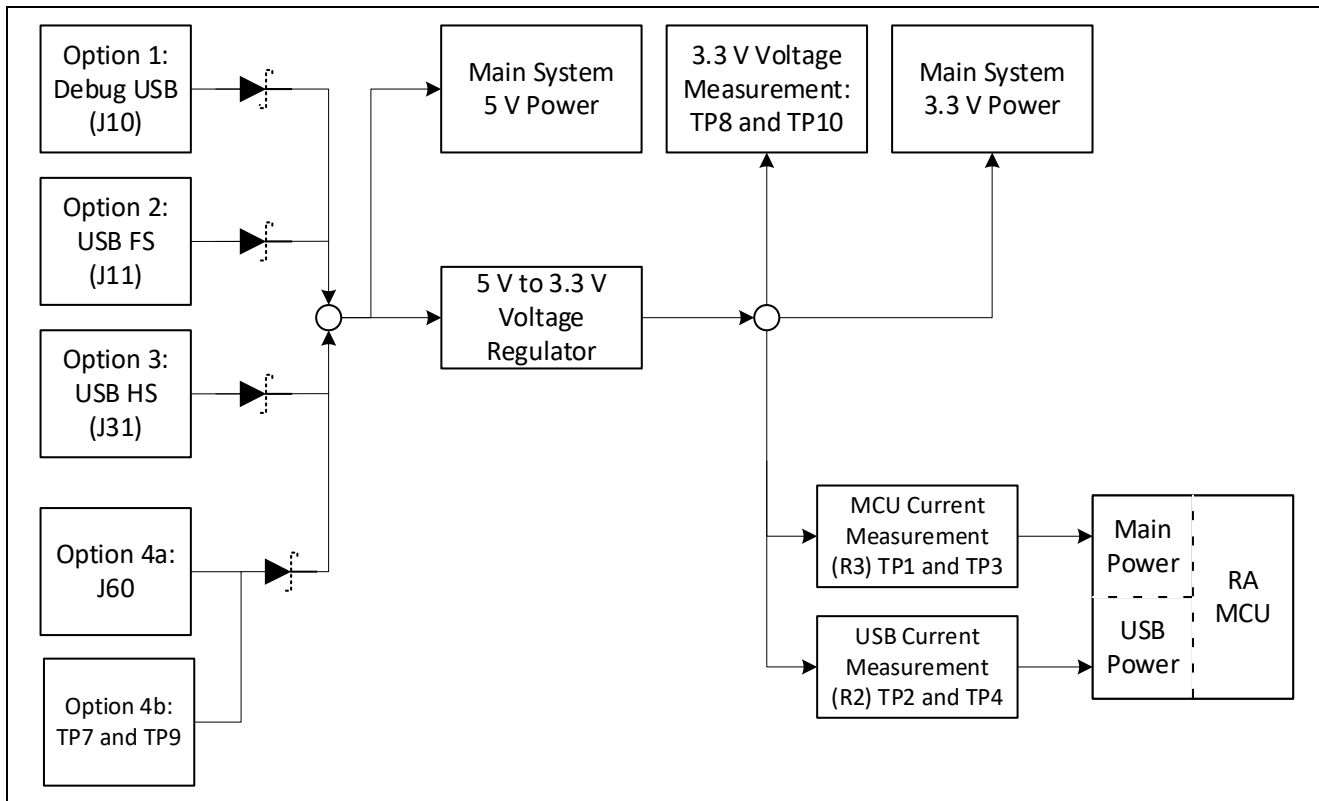

Figure 8. Power Supply Options

5.1.1.1 Option 1: Debug USB

5 V may be supplied from an external USB host to the USB Debug connector (J10) labelled DEBUG1 on the board. Power from this source is connected to the main system 5 V power. Reverse current protection is provided between this connector and the main system 5 V power.

5.1.1.1 Option 2: USB Full Speed

5 V may be supplied from an external USB host to the USB Full Speed connector (J11) labelled USB FULL SPEED on the board. Power from this source is connected to the main system 5 V power. Reverse current protection is provided between this connector and the main system 5 V power.

5.1.1.2 Option 3: USB High Speed

5 V may be supplied from an external USB host to the USB High Speed connector (J31) labelled USB HIGH SPEED on the board. Power from this source is connected to the main system 5 V power. Reverse current protection is provided between this connector and the main system 5 V power.

5.1.1.3 Option 4: 5V Test Points

5 V may be supplied from an external power supply to test points on the board. TP7 (5 V) and TP9 (GND) are loop-style test points, and J60 provides large via style test points that can accommodate a 0.1" pin header or connector. The two types of test points are electrically equivalent, and both are provided for user convenience. Power from this source is connected to the main system 5 V power. Reverse current protection is provided between the 5 V test points and the main system 5 V power. TP7 (5 V), TP9 (GND) and J60 can be found at the top left of the board above Pmod1.

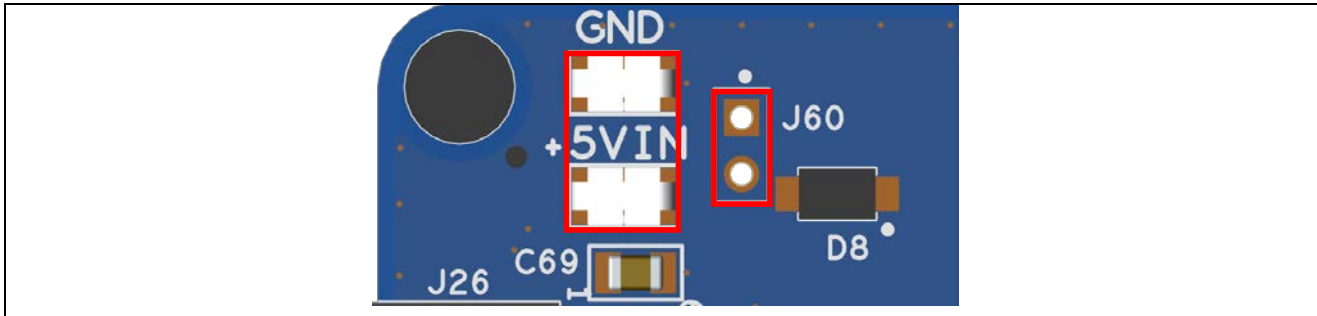

Figure 9. Test Point Location

5.1.2 Power Supply Considerations

The on-board LDO regulator which supplies +3.3 V has a built-in current limit of 2.0 A. Make sure the total current required by the RA MCU, any active on-board features, and any connected peripheral devices does not exceed this limit.

Note: The total current available from a typical enumerated USB host is 500 mA maximum. Depending on the configuration of the kit, multiple power sources may be required.

5.1.3 Power-up Behavior

When powered, the white LED near the center of the board (the “dash” in the EK-RA8M1 name) will light up. For more details on initial power up behavior, see the *EK-RA8M1 Quick Start Guide*.

5.2 Debug and Trace

The EK-RA8M1 board supports the following three debug modes.

Table 3. Debug Modes

Debug Modes	Debugger MCU (the device that connects to the IDE on PC)	Target MCU (the device that is being debugged)	Debugging Interface/Protocol	Connector Used
Debug on-board	RA4M2 (on-board)	RA8M1 (on-board)	SWD, SWO, JTAG	Micro USB (J10)
Debug in	External debugging tools	RA8M1 (on-board)	SWD, SWO, ETM, JTAG	20-pin connector (J20) or 10-pin connector (J13)
Debug out	RA4M2 (on-board)	Any external RA MCU	SWD, SWO, JTAG	Micro USB (J10) plus either 20-pin connector (J20) or 10-pin connector (J13)

Notes:

- See Table 5 for the Debug USB connector pin definition.
- See Table 8 for the 20-pin JTAG connector pin definition.
- See Table 9 for the 10-pin JTAG connector pin definition.

The following table summarizes the jumper configuration for each of the debug modes.

Table 4. Jumper Connection Summary for Different Debug Modes

Debug Modes	J6	J8	J9	J29
Debug on-board	Open	Jumper on pins 1-2	Open	Jumpers on pins 1-2, 3-4, 5-6, 7-8
Debug in	Open	Jumper on pins 1-2	Closed	Jumpers on pins 1-2, 3-4, 5-6, 7-8
Debug out	Open	Jumper on pins 2-3	Open	All pins open

5.2.1 Debug On-Board

The on-board debug functionality is provided using J-Link On-Board Debug MCU and SEGGER J-Link® firmware. Debug USB micro-B connector (J10) connects the J-Link On-Board Debug MCU to an external USB Full Speed Host, allowing re-programming and debugging of the target RA MCU firmware. This connection is the default debug mode for the EK-RA8M1 board.

The J-Link On-Board Debug MCU connects to the target RA MCU using the SWD interface.

Table 5. Debug USB Port Assignments

Debug USB Connector		EK-RA8M1
Pin	Description	Signal/Bus
J10-1	+5 VDC	+5V_USB_DBG
J10-2	Data-	USB_JLOB_N (U7-14)
J10-3	Data+	USB_JLOB_P (U7-15)
J10-4	USB ID, jack internal switch, cable inserted	N.C.
J10-5	Ground	GND

A yellow indicator, LED5, shows the visual status of the debug interface. When the EK-RA8M1 board is powered on, and LED5 is blinking, it indicates that the J-Link On-Board Debug MCU is not connected to a programming host. When LED5 is on solid, it indicates that the J-Link On-Board Debug MCU is connected to a programming interface.

To configure the EK-RA8M1 board to use the Debug On-Board mode, configure the jumpers using the following table.

Table 6. Debug On-Board Jumper Configuration

Location	Default Open/Closed	Function
J6	Open	Target RA MCU MD connected to debug
J8	Jumper on pins 1-2	Target RA MCU RESET# connected to debug RESET#
J9	Open	J-Link On-Board Debug MCU in normal operation mode
J29	Jumpers on pins 1-2, 3-4, 5-6, 7-8	Target RA MCU debug signals connected to the debug interface

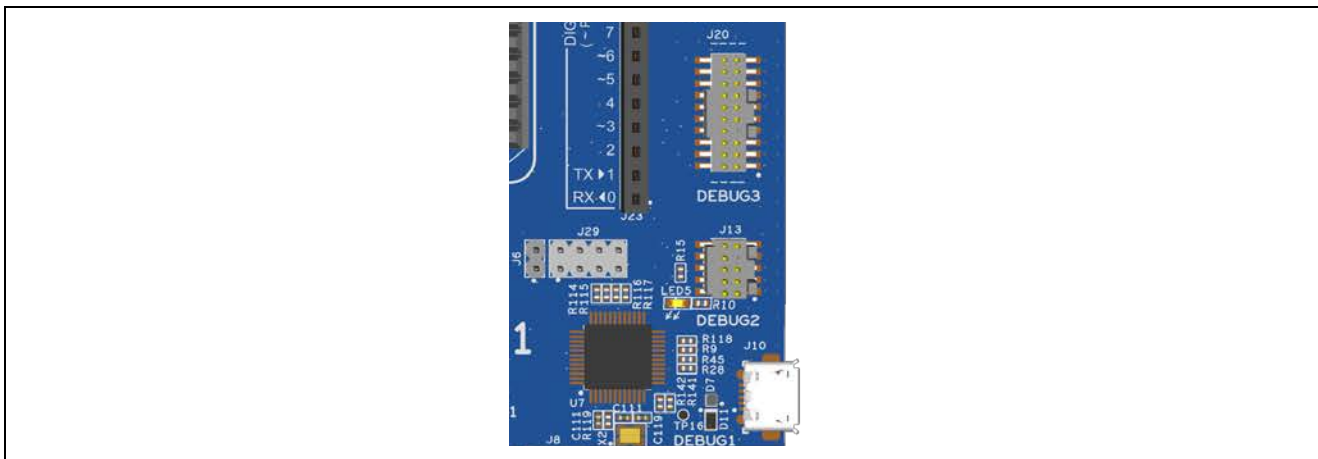

Figure 10. EK-RA8M1 Debug Interface

5.2.2 Debug In

One 20-pin Cortex® Debug Connector at J20 supports JTAG, SWD, SWO and ETM (TRACE) debug. One 10-pin Cortex® Debug Connector at J13 supports JTAG, SWD and SWO. Either of these connectors may be used for external debug of the target RA MCU.

To configure the EK-RA8M1 board to use the Debug In mode, configure the jumpers as shown in Table 7.

Table 7. Debug In Mode Jumper Configuration

Location	Default Open/Closed	Function
J6	Open	Target RA MCU MD connected to debug
J8	Jumper on pins 1-2	Target RA MCU RESET# connected to debug RESET#
J9	Closed	J-Link On-Board Debug MCU is held in RESET
J29	Jumpers on pins 1-2, 3-4, 5-6, 7-8	Target RA MCU debug signals connected to the debug interface

Table 8. JTAG/SWO/SWD/ETM Debug Port Assignments

JTAG Connector				EK-RA8M1
Pin	JTAG Pin Name	SWD Pin Name	ETM Pin Name	Signal/Bus
J20-1	Vtref	Vtref	Vtref	+3.3 V
J20-2	TMS	SWDIO	TMS / SWDIO	P210/SWDIO/TMS
J20-3	GND	GND	GND	GND
J20-4	TCK	SWCLK	TCK / SWCLK	P211/SWCLK/TCK
J20-5	GND	GND	GND	GND
J20-6	TDO	SWO	TDO / SWO	P209/SWO/TDO
J20-7	Key	Key	Key	N.C.
J20-8	TDI	N/A	TDI / N/A	P208/TDI
J20-9	GNDDetect	GNDDetect	GNDDetect	GND (cut E30 to open)
J20-10	nSRST	nSRST	nSRST	RESET#
J20-11	GND	GND	GND	GND
J20-12	N/A	N/A	TCLK	P308/TCLK*
J20-13	GND	GND	GND	GND
J20-14	N/A	N/A	TDATA0	P307/TDATA0*
J20-15	GND	GND	GND	GND
J20-16	N/A	N/A	TDATA1	P306/TDATA1*
J20-17	GND	GND	GND	GND
J20-18	N/A	N/A	TDATA2	P305/TDATA2*
J20-19	GND	GND	GND	GND
J20-20	N/A	N/A	TDATA3	P304/TDATA3*

* Option selection by J61 or P115. Please check section 5.4.2.

Table 9. JTAG/SWO/SWD Debug Port Assignments

JTAG Connector			EK-RA8M1
Pin	JTAG Pin Name	SWD Pin Name	Signal/Bus
J13-1	Vtref	Vtref	+3.3 V
J13-2	TMS	SWDIO	P210/TMS/SWDIO
J13-3	GND	GND	GND
J13-4	TCK	SWCLK	P211/TCK/SWCLK
J13-5	GND	GND	GND
J13-6	TDO	SWO	P209/SWO/TDO
J13-7	Key	Key	N.C.
J13-8	TDI	N/A	P208/TDI
J13-9	GNDDetect	GNDDetect	GND (cut E30 to open)
J13-10	nSRST	nSRST	RESET#

Note: The Cortex® Debug Connector is fully described in the Arm® CoreSight™ Architecture Specification.

5.2.3 Debug Out

The EK-RA8M1 board can be configured to use the J-Link On-Board Debug MCU to debug target RA MCU on an external board.

A yellow indicator, LED5, shows the visual status of the debug interface. When the EK-RA8M1 board is powered on, and LED5 is blinking, this indicates that the J-Link On-Board Debug MCU is not connected to a programming host. When LED5 is on solid, this indicates that the J-Link On-Board Debug MCU is connected to a programming interface. When the debug interface is actively in use, the LED will flicker randomly.

To configure the EK-RA8M1 board to use the Debug Out mode, configure the jumpers according to the following table.

Table 10. Debug Out Jumper Configuration

Location	Default Open/Closed	Function
J6	Open	No connection to RA MCU
J8	Jumper on pins 2-3	On-board RA MCU is held in RESET
J9	Open	J-Link On-Board Debug MCU in normal operation mode
J29	All jumpers removed	Disconnects the on-board RA MCU debug signals from the debug interface

5.3 Ecosystem

The System Control and Ecosystem area provides users the option to simultaneously connect several third-party add-on modules compatible with five most popular ecosystems using the following connectors:

1. Two Seeed Grove® system (I²C and I³C) connectors (not populated)
2. One SparkFun Qwiic® connector (not populated)
3. Two Digilent Pmod™ (SPI, UART and I²C/I³C) connectors
4. Arduino™ (Uno R3 / R4) connector
5. MikroElektronika mikroBUS™ connector

5.3.1 Seeed Grove® Connectors

5.3.1.1 Grove 1

A Seeed Grove® I³C connector footprint is provided at J27. The RA MCU acts as a two-wire serial master, and a connected module acts as a two-wire serial slave.

Table 11. Grove 1 Port Assignments

Grove 1 Connector		EK-RA8M1
Pin	Description	Signal/Bus
J27-1	I3C_SCL	P400 (I3C_SCL0)*
J27-2	I3C_SDA	P401 (I3C_SDA0)*
J27-3	VCC	+3.3 V
J27-4	GND	GND

* Option selection for connection between MCU pins and ecosystem connectors by J61 or P115. Please check section 5.4.2.

5.3.1.2 Grove 2

A Seeed Grove® I²C connector footprint is provided at J28. The RA MCU acts as a two-wire serial master, and a connected module acts as a two-wire serial slave.

To configure for I²C function, complete links E39 and E40, and unlink E41 and E42.

To configure for analog function, unlink E39 and E40, and complete links E41 and E42.

Table 12. Grove 2 Port Assignments

Grove 2 Connector		EK-RA8M1	
Pin	Description	Signal/Bus	
J28-1	SCL1/AN	P512 (SCL1)	P005 (AN001)*
J28-2	SDA1/AN	P511 (SDA1)	P002 (AN102)*
J28-3	VCC	+3.3 V	
J28-4	GND	GND	

* Jumpers E39 and E40 are open, E41 and E42 are closed.

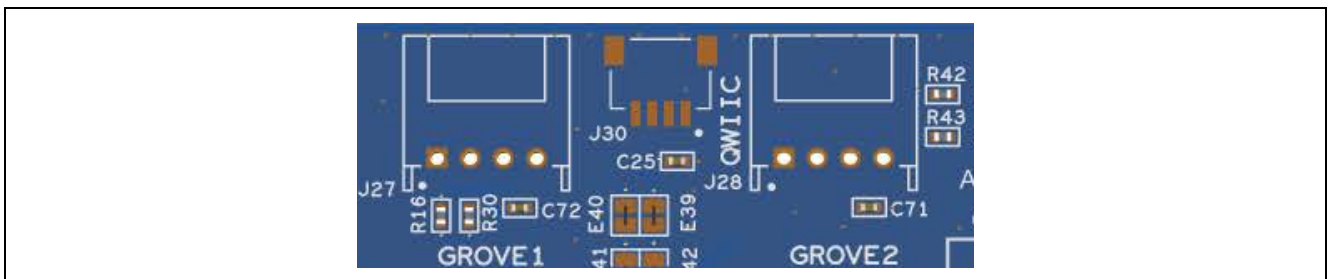

Figure 11. Seed Grove® and SparkFun Qwiic® Connector Footprints

5.3.2 SparkFun Qwiic® Connector

A SparkFun Qwiic® connector footprint is provided at J30. The main MCU acts as a two-wire serial master, and a connected module acts as a two-wire serial slave (data lines shared with Grove 1).

Table 13. Qwiic® Port Assignments

Qwiic® Connector		EK-RA8M1	
Pin	Description	Signal/Bus	
J30-1	GND	GND	
J30-2	VCC	+3.3 V	
J30-3	I3C_SCL	P400 (SCL0)*	
J30-4	I3C_SDA	P401 (SDA0)*	

* Option selection for connection between MCU pins and ecosystem connectors by J61 or P115. Please check section 5.4.2.

* Note: The SDA and SCL connectors are incorrectly swapped compared to the SparkFun Qwiic® definition. Please manage the connection swap by modifying the cable.

5.3.3 Digilent Pmod™ Connectors

Two 12-pin connectors are provided to support Pmod modules where the RA MCU acts as the master, and the connected module acts as a slave device.

These interfaces may be configured in firmware to support several Pmod types such as Type-2A (expanded SPI) and Type-3A (expanded UART).

The EK-RA8M1 board also provides jumpers so the 12-pin connector may alternatively be used for Pmod Type-6A (I²C).

The default 12-pin Pmod interface supports +3.3 V devices. Please ensure that any Pmod device installed is compatible with a +3.3 V supply.

The 6-pin Pmod interface option for Type-6 (I²C) may also support +5.0 V devices. Please ensure that only 6-pin modules are used when this option is selected.

Note: Both Pmods use the SCI peripheral in “Simple SPI” mode, and so do not offer the full functionality of the SPI peripheral. Please see the hardware manual for full details of the SCI “Simple SPI” mode.

5.3.3.1 Pmod 1

A 12-pin Pmod connector is provided at J26, Pmod 1.

This Pmod connector is controlled by a jumper option (J61) or P115. Please check section 5.4.2. as the signals needed are shared with the Ethernet-B. Pmod 1 option type-6A and Ethernet-B cannot be used concurrently.

Table 14. Pmod 1 Port Assignments

Pmod 1 Connector				EK-RA8M1	Pmod 1 Configuration	
Pin	Option Type-2A (SPI)	Option Type-3A (UART)	Option Type-6A (I ² C/I3C)*	Signal/Bus	Short	Open
J26-1	SSL			P612 (SSL0)	E19	E17
		CTS		P613 (CTS0)	E17	E19
J26-2	MOSI	TXD		P609 (MOSI0/TXD0)		
J26-3	MISO	RXD		P610 (MISO0/RXD0)	E51	E37
			SCL	P400 (SCL0)*	E37	E51
J26-4	SCK			P611 (SCK0)	E20	E18, E38
		RTS		P612 (RTS0)	E18	E20, E38
			SDA	P401 (SDA0)*	E38	E18, E20
J26-5	GND			GND		
J26-6	VCC			+3.3 V	E25	E36
				+5.0 V	E36	E25
J26-7	IRQ			P006 (IRQ11)		
J26-8	RESET (master to slave)			PA08		
J26-9	GPIO			P614		
J26-10	GPIO			P615		
J26-11	GND			GND		
J26-12	VCC			+3.3 V	E25	E36
				+5.0 V	E36	E25

* Option selection for connection between MCU pins and ecosystem connectors by J61 or P115. Please check section 5.4.2.

Caution: 5 V optional supply is provided (J26-6 and J26-12), however the interface must only be driven with 3.3 V signals from the Pmod. The EK-RA8M1 will only provide 3.3 V signal levels to the Pmod.

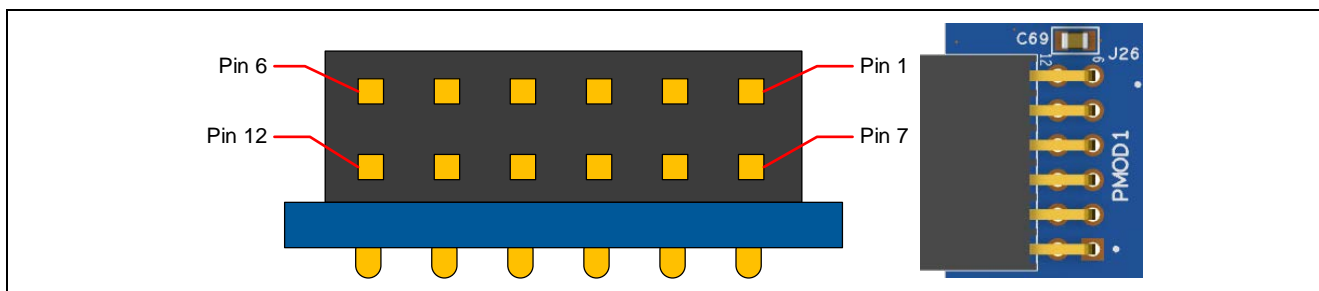

Figure 12. Pmod 1 Connector

5.3.3.2 Pmod 2

A 12-pin Pmod connector is provided at J25, Pmod 2.

These interfaces may be configured in firmware to support several Pmod types such as Type-2A (expanded SPI) and Type-3A (expanded UART).

Note: Both Pmods use the SCI peripheral in “Simple SPI” mode, and so do not offer the full functionality of the SPI peripheral. Please see the hardware manual for full details of the SCI “Simple SPI” mode.

Table 15. Pmod 2 Port Assignments

Pmod 2 Connector			EK-RA8M1	Pmod 2 Configuration	
Pin	Option Type-2A (SPI)	Option Type-3A (UART)	Signal/Bus	Short	Open
J25-1	SSL		PA05 (SSL2)	E15	E10
J25-1		CTS	PA06 (CTS2)	E10	E15
J25-2	MOSI	TXD	PA03 (TXD2/MOSI2)		
J25-3	MISO	RXD	PA02 (RXD2/MISO2)		
J25-4	SCK		PA04 (SCK2)	E16	E14
J25-4		RTS	PA05 (RTS2)	E14	E16
J25-5	GND		GND		
J25-6	VCC		+3.3 V		
J25-7	IRQ		P508 (IRQ1)		
J25-8	RESET (master to slave)		P809		
J25-9	GPIO		P810		
J25-10	GPIO		P811		
J25-11	GND		GND		
J25-12	VCC		+3.3 V		

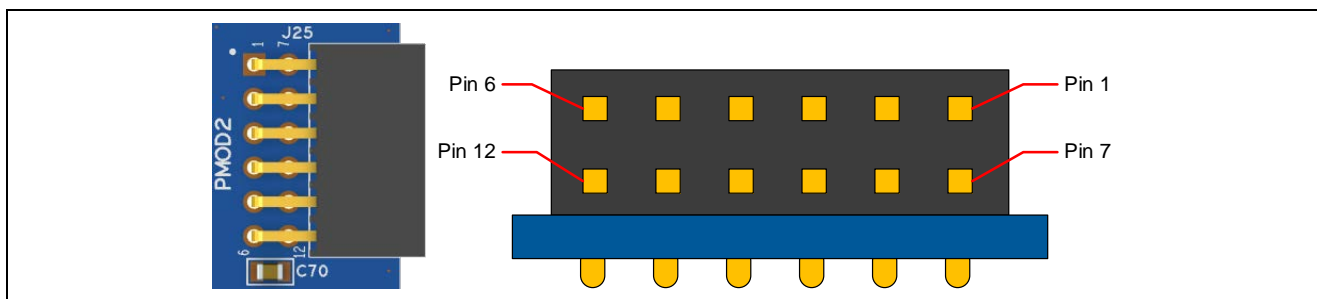

Figure 13. Pmod 2 Connector

5.3.4 Arduino™ Connector

Near the center of the System Control and Ecosystem Access area is an Arduino Uno R3 / R4 compatible connector interface.

Table 16. Arduino Uno Port Assignments

Arduino Compatible Connector		EK-RA8M1
Pin	Description	Signal/Bus
J18-1	N.C.	N.C.
J18-2	IOREF	+3.3 V
J18-3	RESET	P812
J18-4	+3.3 V	+3.3 V
J18-5	+5 V	+5 V
J18-6	GND	GND
J18-7	GND	GND
J18-8	VIN	N.C.

Arduino Compatible Connector		EK-RA8M1		
Pin	Description	Signal/Bus		
J19-1	A0	P004 (AN000)		
J19-2	A1	P003 (AN104)		
J19-3	A2	P007 (AN004)		
J19-4	A3	P001 (AN101)		
J19-5	A4	P014 (AN007/DA0)		
J19-6	A5	P015 (AN105/DA1)		
J23-1	D0	RXD	P309 (GPIO/RXD3)	
J23-2	D1	TXD	P310 (GPIO/TXD3)	
J23-3	D2	INT0	P906 (GPIO/IRQ9)	
J23-4	D3	INT1	PWM	P907 (GPIO/IRQ10/GTIOC13A)
J23-5	D4		P905 (GPIO)	
J23-6	D5		PWM	P601 (GPIO/GTIOC6A)
J23-7	D6		PWM	P602 (GPIO/GTIOC7B)
J23-8	D7		P908 (GPIO)	
J24-1	D8		P909 (GPIO)	
J24-2	D9		PWM	P603 (GPIO/GTIOC7A)
J24-3	D10	SPI_SS	P413 (GPIO/SSLB0)	
J24-4	D11	SPI_MOSI	PWM	P411 (GPIO/MOSIB/GTIOC9A)
J24-5	D12	SPI_MISO	PWM	P410 (GPIO/MISOB/GTIOC9B)
J24-6	D13	SPI_SCK	P412 (GPIO/RSPCKB)	
J24-7	GND		GND	
J24-8	AREF		ARDUINO_AREF (linked to VREFH via E43)	
J24-9	SDA		P401 (I3C_SDA0)*	
J24-10	SCL		P400 (I3C_SCL0)*	

* Option selection for connection between MCU pins and ecosystem connectors by J61 or P115. Please check section 5.4.2.

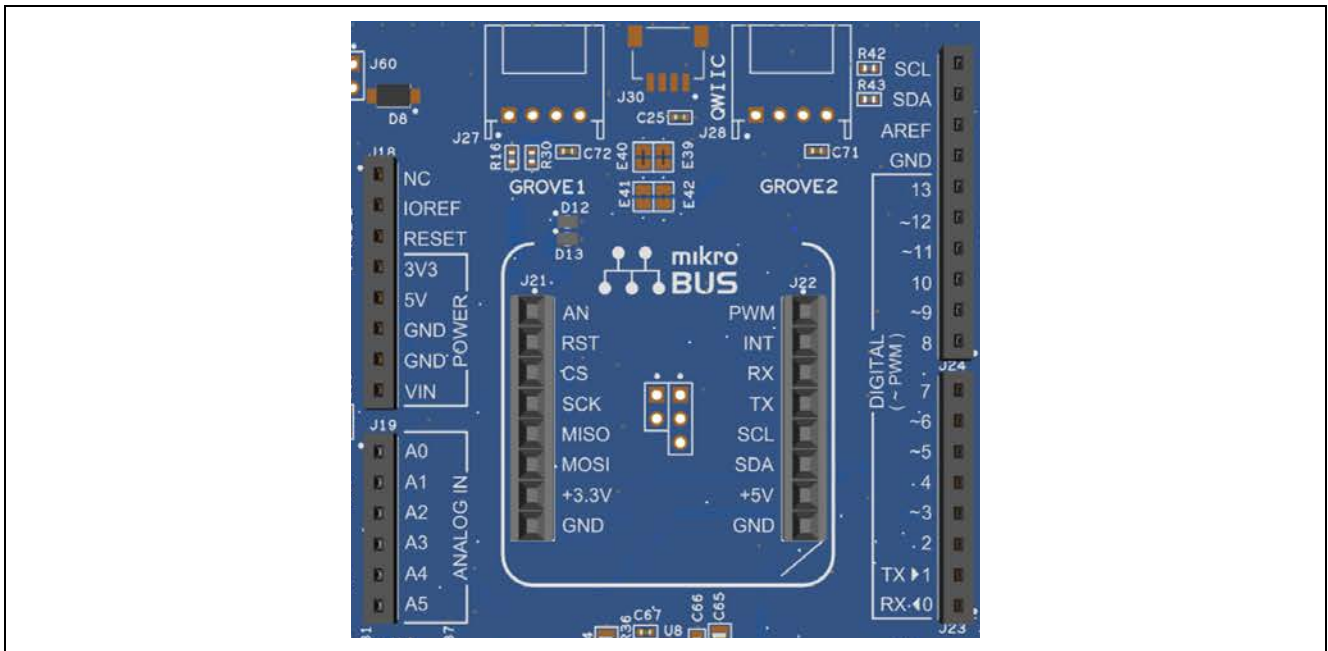

Figure 14. Arduino Uno Connectors

5.3.5 MikroElektronika mikroBUS™ Connector

In the center of the System Control and Ecosystem Access area is a mikroBUS™ compatible connector interface. This interface is compliant with mikroBUS™ Standard Specifications revision 2.00.

Table 17. mikroBUS™ Assignments

mikroBUS™ Connector		EK-RA8M1
Pin	Description	Signal/Bus
J21-1	AN (Analog)	P004 (AN000)
J21-2	RST (Reset)	P502
J21-3	CS (SPI Chip Select)	P413 (SSLB0)
J21-4	SCK (SPI Clock)	P412 (RSPCKB)
J21-5	MISO	P410 (MISOB)
J21-6	MOSI	P411 (MOSIB)
J21-7	+3.3 V	+3.3 V
J21-8	GND	GND
J22-1	PWM	P907 (GTIOC13A)
J22-2	INT (Hardware Interrupt)	P010 (IRQ14)
J22-3	RX (UART Receive)	P309 (RXD3)
J22-4	TX (UART Transmit)	P310 (TXD3)
J22-5	SCL (I ² C Clock)	P400 (SCL0)*
J22-6	SDA (I ² C Data)	P401 (SDA0)*
J22-7	+5 V	+5 V
J22-8	GND	GND

* Option selection for connection between MCU pins and ecosystem connectors by J61 or P115. Please check section 5.4.2.

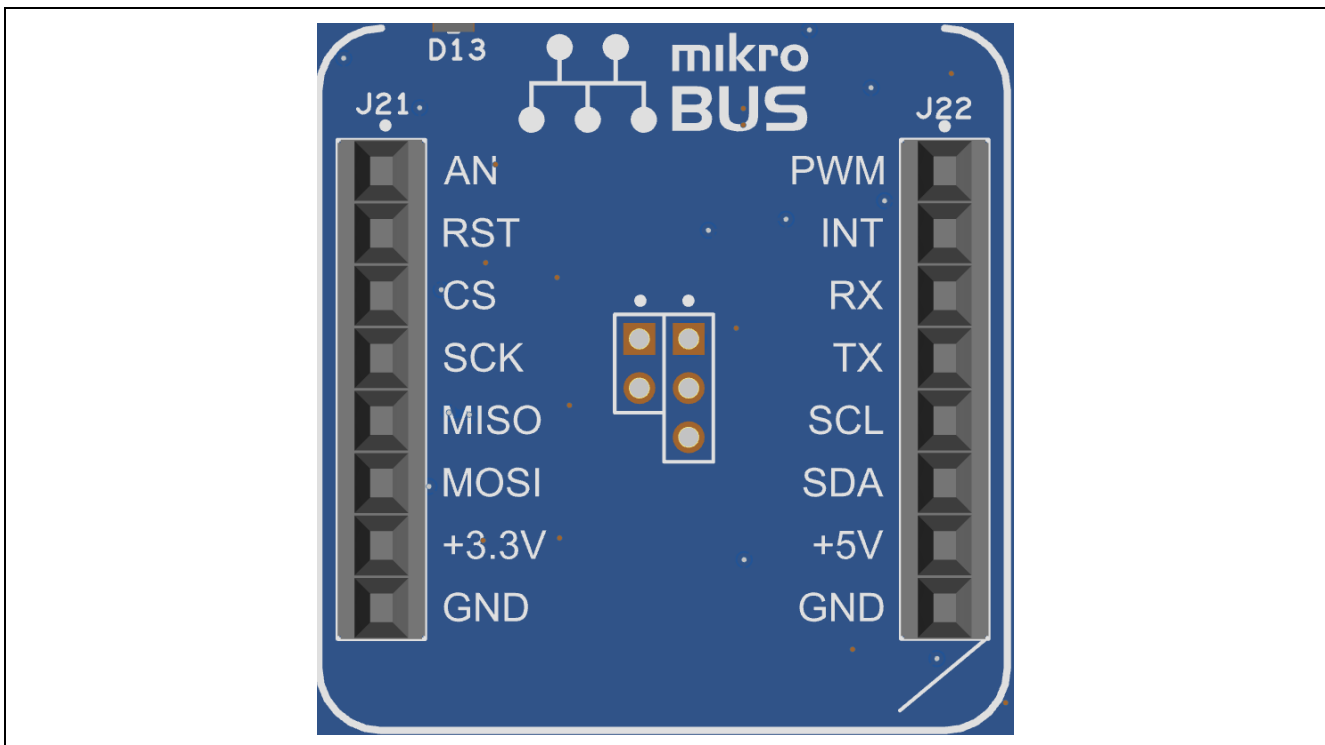

Figure 15. mikroBUS™ Connection

5.4 Connectivity

5.4.1 USB Full Speed

The USB micro-AB connection jack (J11) connects the RA MCU USB Full Speed interface to an external USB interface, allowing communications for testing and use of the RA MCU firmware. This connection can be configured as either a USB device or a USB host interface.

For a USB Device configuration, set jumper J12 to pins 2-3, install a jumper on J15 pins 1-2, and configure the RA MCU firmware to use the USB Full Speed ports in device mode. Power from an external USB Host on this connection can be used to provide power to the EK-RA8M1 board.

For a USB Host configuration, set jumper J12 to pins 1-2, remove the jumper from J15, and configure the RA MCU firmware to use the USB Full Speed ports in host mode. In this configuration, power to J11 is supplied from U6. The total current available from U6 is 500 mA. Note that the input power sources must be configured with enough power for both the EK-RA8M1 board and the USB Full Speed port in host mode. Connect the included USB type-A female to micro-B male cable to J11. USB device cables or devices can be connected to the USB Full Speed port using this cable.

Table 18. USB Full Speed Port Assignments

USB Full Speed Connector		EK-RA8M1
Pin	Description	Signal/Bus
J11-1	+5 VDC	+5V_USBFS (Host Mode) ^{*1} P407/USB_VBUS = 2/3 of +5V_USBFS at J11 ^{*2}
J11-2	Data-	USBF_N
J11-3	Data+	USBF_P
J11-4	USB ID, jack internal switch, cable inserted	N.C.
J11-5	Ground	GND

^{*1} When J12 is linked 1-2 and J15 is open

^{*2} When J12 is linked 2-3 and J15 is closed

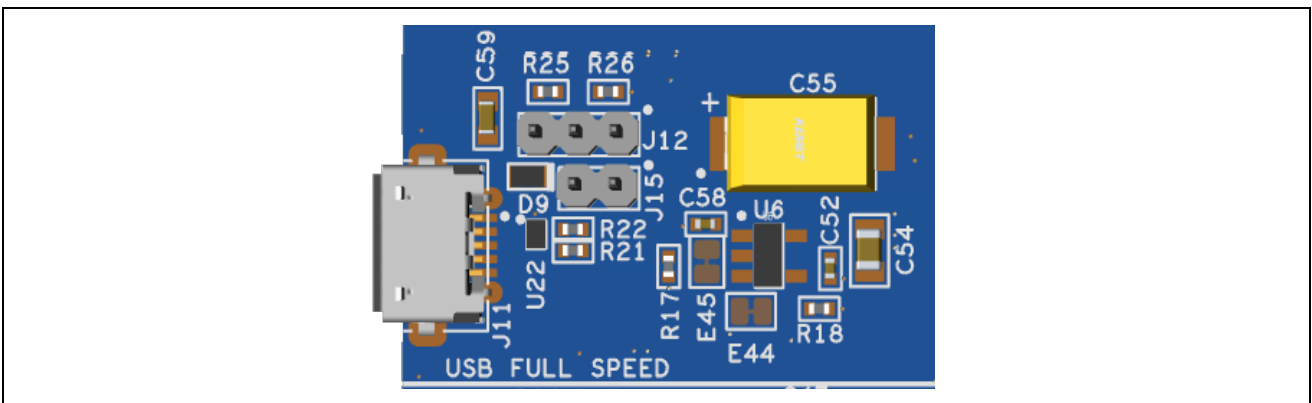

Figure 16. USB Full Speed Connector

5.4.2 I3C

The Arduino, mikroBUS™, Grove 1, Qwiic®, and Pmod 1 connectors connect the RA MCU I3C interface to external I3C or I²C devices, allowing communications between devices.

Please ensure that J61 or P115 are set correctly.

For I²C set PB00 and P711 to outputs driven high to enable the pull-ups. For I3C set the pins to high impedance unless the I3C specification requires pull ups. In which case, drive PB00 and P711 high. Please refer to the I3C specification for management and control of the I3C pull-ups.

The required configurations can be seen in Table 19 where “x” means that the setting does not matter.

Table 19. I²C/I3C Pullup Configuration

I ² C/I3C	J61	P115	PB00/P711
I3C (Ecosystems expansions)	Closed	Pin disable	Input (High impedance) or outputs driven high* ¹
I ² C (Ecosystems expansions)	Closed	Pin disable	Outputs driven high
I3C (Ecosystems expansions)	x	Low	Input (High impedance) or outputs driven high* ¹
I ² C (Ecosystems expansions)	x	Low	Outputs driven high
I3C (Breakout pin header)	Open	Pin disable	x
I3C (Breakout pin header)	x	High	x

*¹Please refer to the I3C specification for management and control of the I3C pull-ups

5.5 Miscellaneous

5.5.1 User and Power LEDs

Five LEDs are provided on the EK-RA8M1 board. In addition, the Ethernet connector has built-in link status and link speed LEDs.

Behavior of the LEDs on the EK-RA8M1 board is described in the following table.

Table 20. EK-RA8M1 Board LED Functions

Designator	Color	Function	MCU Control Port
LED1	Blue	User LED	P600
LED2	Green	User LED	P414
LED3	Red	User LED	P107
LED4	White	Power on indicator	+3.3 V
LED5	Yellow	Debug LED	J-Link OB MCU

The user LEDs may be isolated from the main MCU, so the associated ports can be used for other purposes. To separate LED1 from P600, trace-cut jumper E27 must be open. To separate LED2 from P414, trace-cut jumper E26 must be open. To separate LED3 from P107, trace-cut jumper E28 must be open.

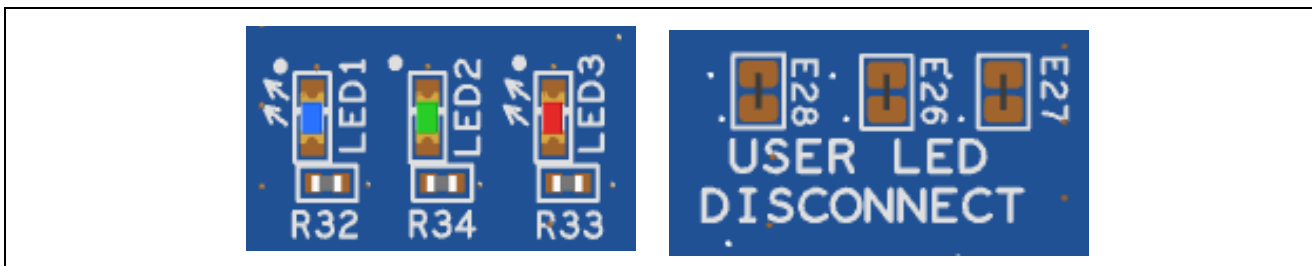

Figure 17. User LEDs



Figure 18. Power LED

5.5.2 User and Reset Switches

Three miniature, momentary, mechanical push-button type SMT switches are mounted on the EK-RA8M1 board.

Pressing the reset switch (S3) generates a reset signal to restart the RA MCU.

Table 21. EK-RA8M1 Board Switches

Designator	Function	MCU Control Port	Button Color
S3	MCU Reset Switch	RESET#	Red
S2	User Switch	P008 (IRQ12-DS)	Blue
S1	User Switch	P009 (IRQ13-DS)	Blue

The user switches S1 and S2 may be isolated from the main MCU, so the associated ports can be used for other purposes. To separate S1 from P009, trace cut jumper E31 must be open. To separate S2 from P008, trace cut jumper E32 must be open.

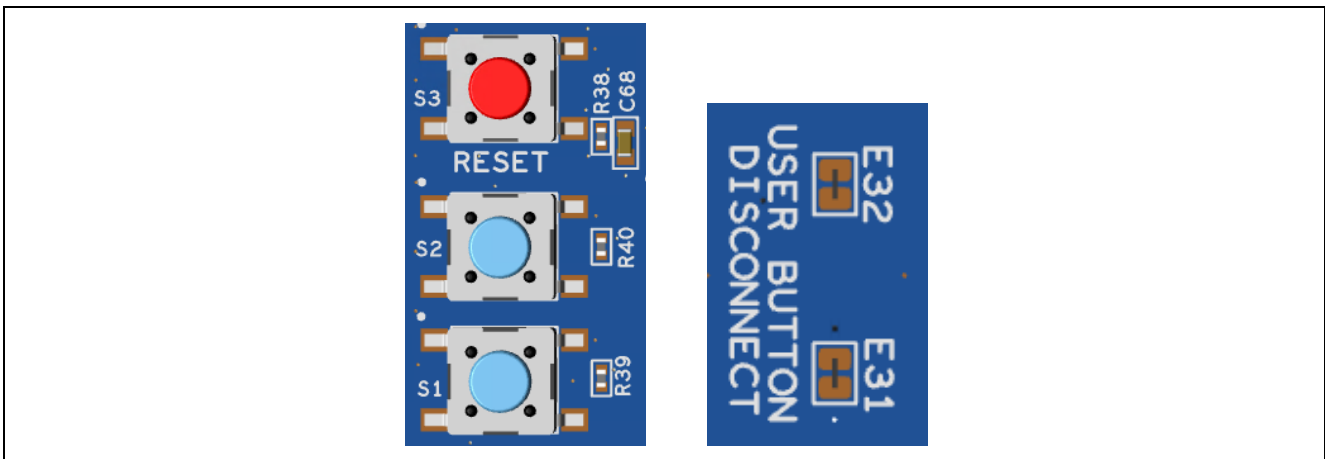

Figure 19. Reset and User Switches

5.5.3 MCU Boot Mode

A two-pin header (J16) is provided to select the boot mode (P201) of the RA MCU. For normal operation, or Single-Chip mode, leave J16 open. To enter SCI Boot mode or USB boot mode, place a jumper on J16.



Figure 20. Boot Mode

5.5.4 Crystals

If the main high-precision crystal oscillator is not needed, then the ports that it is connected to can be used for other purposes.

Table 22. Main 20 MHz Crystal Configuration

20MHz Crystal Oscillator	Configuration
Required	E7 and E11 closed, E12 and E13 open
Not required	E7 and E11 open, E12 and E13 closed. P212 and P213 are available for other purposes.

6. Special Feature Access Area

The Special Feature Access area provides features specific to the RA8M1 MCU group such as Ethernet MAC controller, USB High Speed (host and device) and CAN FD Bus.

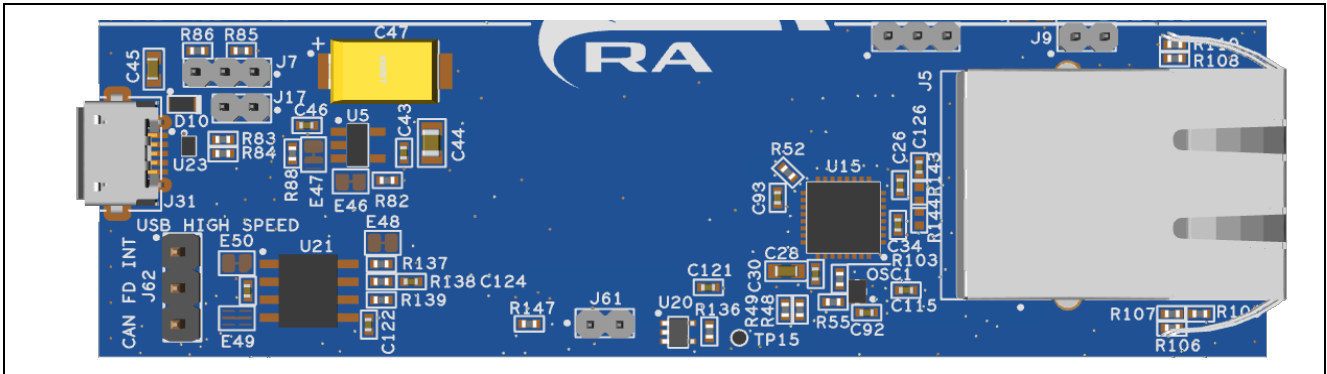

Figure 21. Special Feature Access Area

6.1 CAN FD Bus

The EK-RA8M1 board provides a CAN FD bus transceiver (TJA1042T) that is connected directly to the RA MCU. External connection to the CAN FD bus is made using the 0.1" pitch 3-pin male header J62.

Table 23. CAN FD bus connections between U21 and RA8M1

CAN FD Signal Description	EK-RA8M1 Port
RXD	P311
TXD	P312
STB	P207

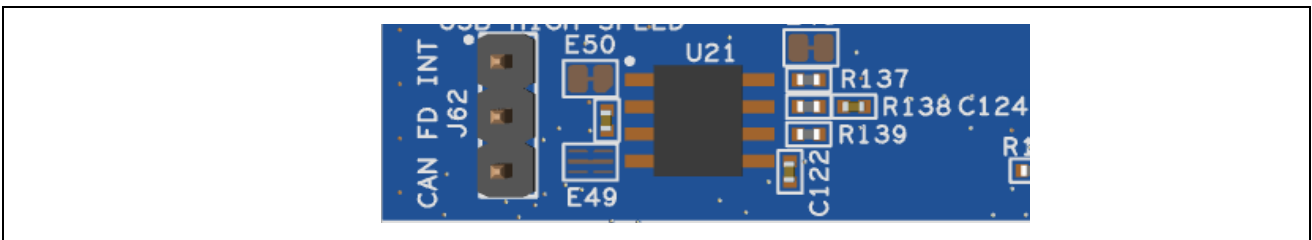

Figure 22. CAN FD Bus

Table 24. CAN FD Port Assignments

J62 Pin	Function
1	CANH
2	CANL
3	GND

6.2 Ethernet

The Ethernet interface uses an RMII Ethernet Physical Layer Transceiver (PHY) (U15), connected to an RJ45 standard Ethernet connector (J5) with integrated magnetics and status indicators. The Ethernet clock is sourced from a precision 50 MHz clock oscillator connected directly to the Ethernet PHY.

The RMII signals used for the Ethernet port are connected from the RA MCU through two sets of bus switches. This is to allow different feature sets of the RA8M1 device to be evaluated, that would otherwise become unavailable. The Jumper J61 and P115 control the peripheral interface option used to communicate with the Ethernet PHY device.

Table 25. Ethernet Port Assignments

Ethernet Signal Description	RA8M1 MCU Port J61 is Closed* or P115 is Low	RA8M1 MCU Port J61 is Open* or P115 is High
INT	P000	P000
MDC	P308	P401
MDIO	P307	P402
TXD1	P305	P406
TXD0	P304	P700
TXD_EN	P306	P405
RXD1	P301	P703
RXD0	P302	P702
RMII/RXDV	P112	P705
RX_ER	P300	P704
REF50CK	P303	P701
RESET#	P404	P404
LINKSTA	P114	P403

*P115 must be set to high impedance setting if you intend to use J61.

Table 26. Ethernet Components

Component	Manufacturer	Manufacturer Part Number
Ethernet PHY	Renesas	ICS1894-32
RJ45 Connector	Pulse	J0011D21BNL
50 MHz Oscillator	ECS Inc International	ECS-1612MV

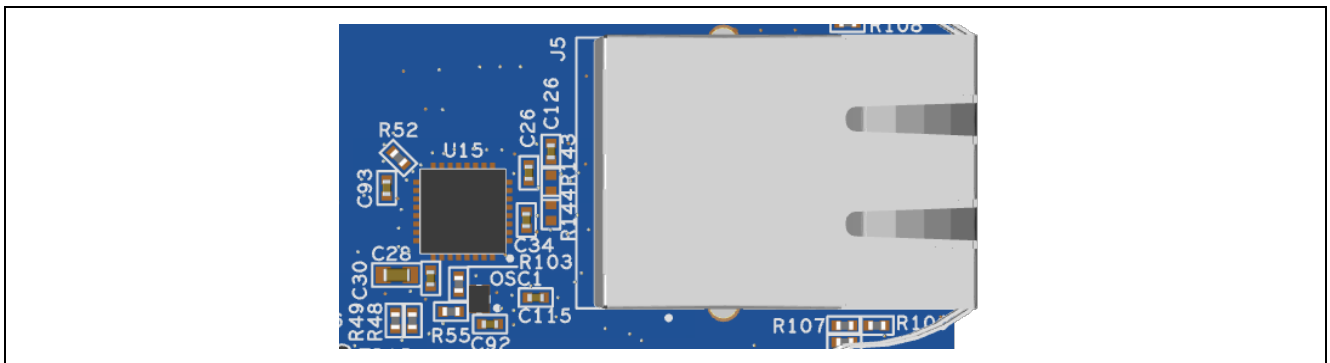

Figure 23. Ethernet Connector

6.3 USB High Speed

The USB micro-AB connection jack (J31) connects the RA MCU USB High Speed interface to an external USB interface, allowing communications for testing and use of the RA MCU firmware. This connection can be configured as either a USB device or a USB host interface.

For a USB device configuration, set jumper J7 to pins 2-3, install a jumper on J17 pins 1-2, and configure the RA MCU firmware to use the USB High Speed ports in device mode. Power from an external USB host on this connection can be used to provide power to the EK-RA8M1 board.

For a USB host configuration, set jumper J7 to pins 1-2, remove the jumper from J17, and configure the RA MCU firmware to use the USB High Speed ports in host mode. In this configuration, power to J7 is supplied from U5. The total current available from U5 is 500 mA. Note that the input power sources must be configured with enough power for both the EK-RA8M1 board and the USB High Speed port in host mode. Connect the included USB type-A female to micro-B male cable to J31. USB device cables or devices can be connected to the USB High Speed port using this cable.

Table 27. USB High Speed Port Assignments

USB High Speed Connector		EK-RA8M1
Pin	Description	Signal/Bus
J31-1	+5 VDC	+5V_USBHS (Host Mode) ^{*1} PB01/USBHS_VBUS = 2/3 of +5V_USBHS at J31 ^{*2}
J31-2	Data-	USBH_N
J31-3	Data+	USBH_P
J31-4	USB ID, jack internal switch, cable inserted	N.C.
J31-5	Ground	GND

^{*1} When J7 is linked 1-2 and J17 is open

^{*2} When J7 is linked 2-3 and J17 is closed

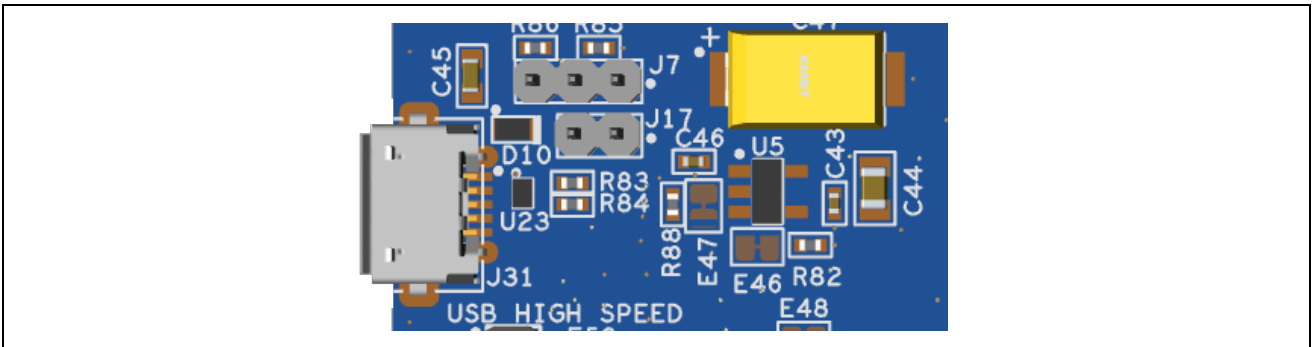

Figure 24. USB High Speed Connector

6.4 Octo-SPI Flash

Included on the EK-RA8M1 board is a 512 Mb (64 MB) Octo-serial flash memory (S28HL512TFPBHI010). The Octo-SPI serial flash device (U3) connects to the Octo-SPI peripheral on the RA MCU and defaults to standard SPI mode initially. The flash memory is enabled for XIP (Execute-In-Place) mode directly after power-on.

The Octo-SPI signals are not provided on an external pin header due to the high speed of this interface.

Table 28. Octo-SPI Flash Port Assignments

Octo-SPI Signal Description	EK-RA8M1 Port
OSPI_RESET#	P106
OSPI_INT#	P105
OSPI_SCLK	P808
OSPI_CS#	P104
OSPI_DS	P801
OSPI_DQ0	P100
OSPI_DQ1	P803
OSPI_DQ2	P103
OSPI_DQ3	P101
OSPI_DQ4	P102
OSPI_DQ5	P800
OSPI_DQ6	P802
OSPI_DQ7	P804

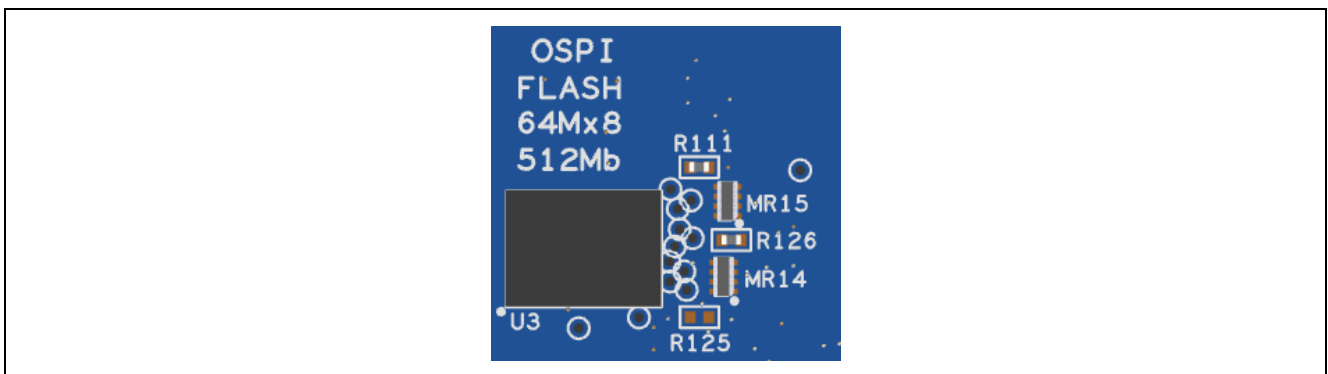

Figure 25. Octo-SPI Flash

Note: The Octo-SPI Flash is among the Special Feature Access features. Normally, it would be in Special Feature Access Area, however, to optimize the layout, routing, and performance, it is placed in the MCU Native Pin Access area.

7. MCU Native Pin Access Area

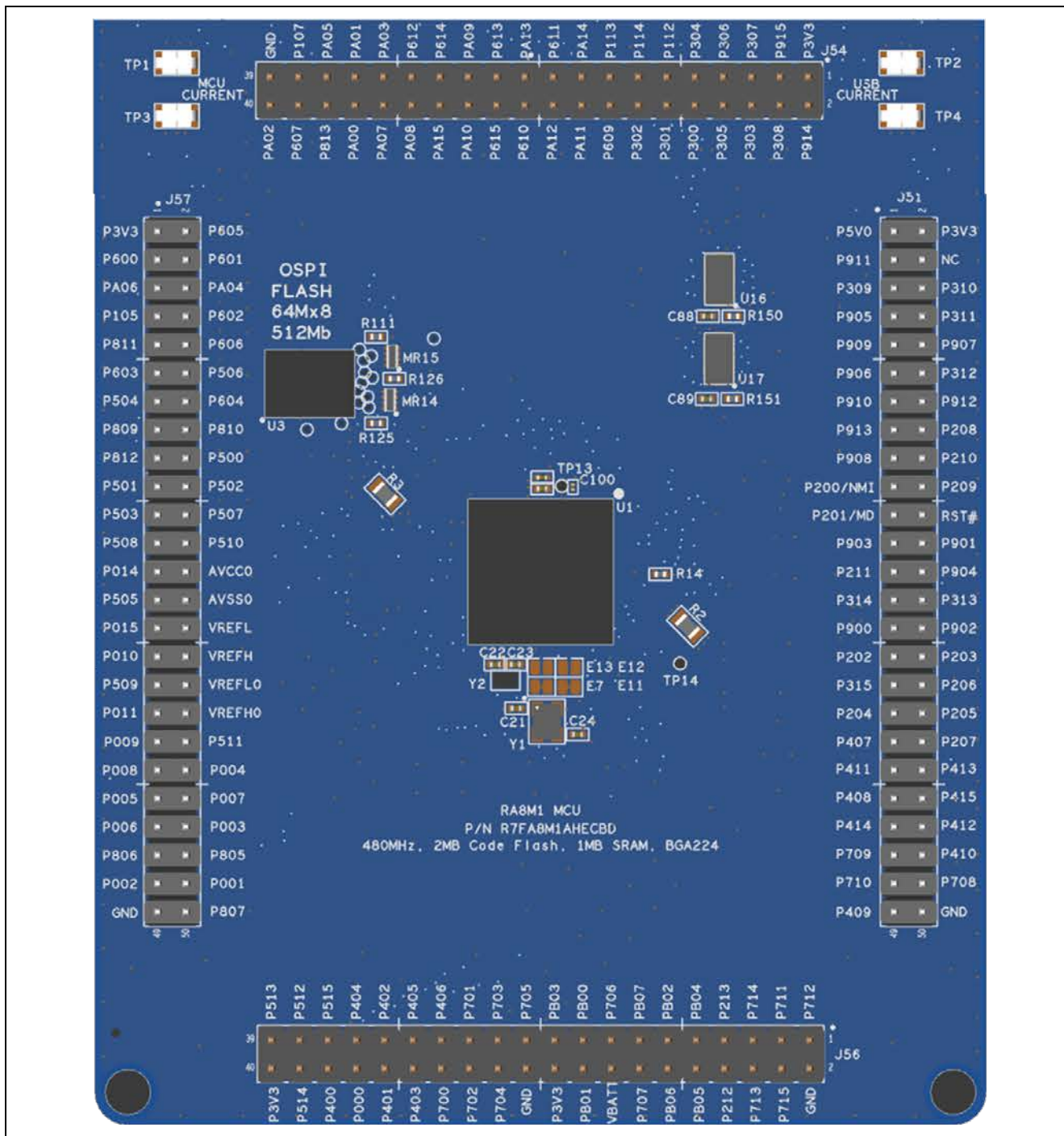

Figure 26. Native Pin Access Area

7.1 Breakout Pin Headers

The EK-RA8M1 board pin headers, J51, J54, J56 and J57 provide access to nearly all RA MCU interface signals, and to voltages for all RA MCU power ports. Each header pin is labelled with the voltage or port connected to that pin. Refer to the RA8M1 MCU Group User's Manual for details of each port function, and the EK-RA8M1 board schematic for pin header port assignments.

The placement of the breakout pin headers allows for a standard 2.54 mm (0.100") center breadboard to be placed on all pin headers simultaneously. This can be used for prototyping and testing of custom circuitry for use with the RA8M1 MCU.

7.2 MCU and USB Current Measurement

Included in the Native Pin Access area are current measurement resistors and test points to measure the MCU USB controller current and the MCU core power current.

The EK-RA8M1 board provides precision 5 mΩ resistors (Vishay, part number WSLP08055L000FEA18) for current measurement of the main 3.3 V MCU power and the 3.3 V USB MCU power. Measure the voltage drop across these resistors and use Ohm's Law to calculate the current. For convenience, TP1 and TP3 are provided to measure the main 3.3 V MCU power, and TP2 and TP4 are provided to measure the 3.3 V USB MCU power. See Figure 29 for the location of TP1, TP2, TP3 and TP4.

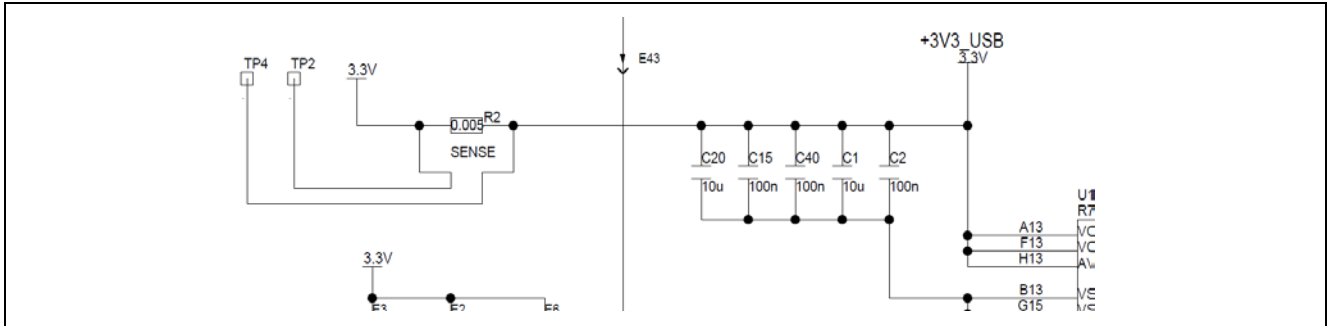

Figure 27. RA USB Current Measurement Circuit

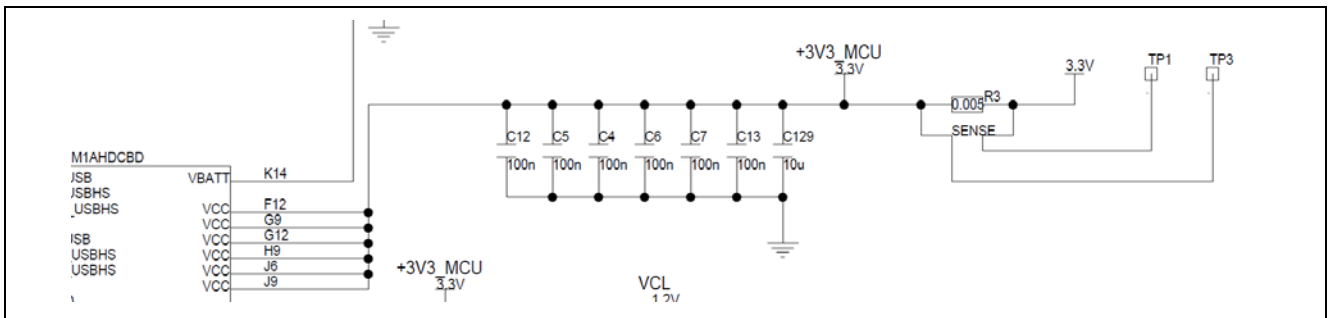

Figure 28. RA +3.3 V Current Measurement Circuit

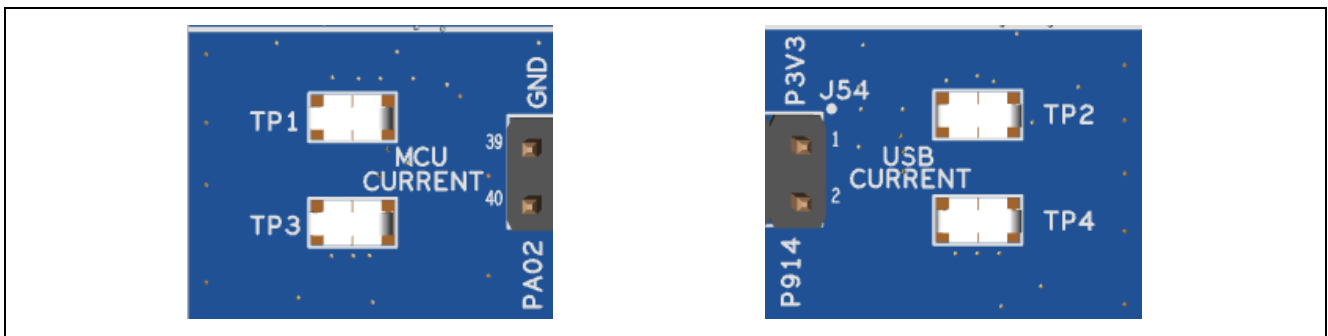

Figure 29. RA MCU and USB Current Measurement

8. Certifications

The EK-RA8M1 v1 kit meets the following certifications/standards. See page 3 of this user's manual for the disclaimer and precautions.

8.1 EMC/EMI Standards

- FCC Notice (Class A)



This device complies with part 15 of the FCC Rules. Operation is subject to the following two conditions: (1) This device may not cause harmful interference, and (2) this device must accept any interference received, including interference that may cause undesired operation.

NOTE- This equipment has been tested and found to comply with the limits for a Class A digital device, pursuant to Part 15 of the FCC Rules. These limits are designed to provide reasonable protection against harmful interference in a residential installation. This equipment generates, uses and can radiate radio frequency energy and, if not installed and used in accordance with the instructions, may cause harmful interference to radio communications. However, there is no guarantee that interference will not occur in a particular installation. If this equipment does cause harmful interference to radio or television reception, which can be determined by turning the equipment off and on, the user is encouraged to try to correct the interference by one or more of the following measures:

- Reorient or relocate the receiving antenna.
- Increase the separation between the equipment and receiver.
- Connect the equipment into an outlet on a circuit different from that to which the receiver is connected.
- Consult the dealer or an experienced radio/television technician for help.

- Innovation, Science and Economic Development Canada ICES-003 Compliance:

CAN ICES-3 (A)/NMB-3(A)

- CE Class A (EMC)



This product is herewith confirmed to comply with the requirements set out in the Council Directives on the Approximation of the laws of the Member States relating to Electromagnetic Compatibility Directive 2014/30/EU.

Warning – This is a Class A product. In a domestic environment this product may cause radio interference in which case the user may be required to take adequate measures to correct this interference.

- UKCA Class A (EMC)



This product is in conformity with the following relevant UK Statutory Instrument(s) (and its amendments): 2016 No. 1091 Electromagnetic Compatibility Regulations 2016.

Warning – This is a Class A product. In a domestic environment this product may cause radio interference in which case the user may be required to take adequate measures to correct this interference.

- Taiwan: CNS 15936, Class A limits 警告：為避免電磁干擾，本產品不應安裝或使用於住宅環境
- Australia/New Zealand AS/NZS CISPR 32:2015, Class A

8.2 Material Selection, Waste, Recycling and Disposal Standards

- EU RoHS
- WEEE Directive (2012/19/EU) & The Waste Electrical and Electronic Equipment Regulations 2013



- The WEEE (Waste Electrical and Electronic Equipment) regulations put responsibilities on producers for the collection and recycling or disposal of electrical and electronic waste. Return of WEEE under these regulations is applicable in the UK and European Union.

- This equipment (including all accessories) is not intended for household use. After use the equipment cannot be disposed of as household waste, and the WEEE must be treated, recycled and disposed of in an environmentally sound manner.

- Renesas Electronics Europe GmbH can take back end of life equipment. Register for this service at;
- <https://www.renesas.com/en/form/weee-questionnaire>
- China SJ/T 113642014, 10-year environmental protection use period.

8.3 Safety Standards

- UL 94V-0

9. Design and Manufacturing Information

The design and manufacturing information for the EK-RA8M1 v1 kit is available in the “EK-RA8M1 v1 Design Package” available on renesas.com/ra/ek-ra8m1.

- Design package file name: ek-ra8m1-v1-designpackage.zip
- Design package contents

Table 29. EK-RA8M1 Board Design Package Contents

File Type	Content	File/Folder Name
File (PDF)	Schematics	ek-ra8m1-v1-schematics
File (PDF)	Mechanical Drawing	ek-ra8m1-v1-mechdwg
File (PDF)	3D Drawing	ek-ra8m1-v1-3d
File (PDF)	BOM	ek-ra8m1-v1-bom
Folder	Manufacturing Files	Manufacturing Files
Folder	Design Files	Design Files - Cadence

10. Website and Support

Visit the following URLs to learn about the kit and the RA family of microcontrollers, download tools and documentation, and get support.

EK-RA8M1 Resources	renesas.com/ek-ra8m1
RA Kit Information	renesas.com/ra/kits
RA Product Information	renesas.com/ra
RA Product Support Forum	renesas.com/ra/forum
RA Videos	renesas.com/ra/videos
Renesas Support	renesas.com/support
RA Flexible Software Package (FSP)	renesas.com/fsp

Revision History

Rev.	Date	Description	
		Page	Summary
1.00	Oct.03.23	—	Initial release
1.10	Oct.13.23	21	Qwiic [®] connections note added.
1.11	Jan.22.24	5, 6, 8, 10, 15, 20, 21	Grove and Qwiic [®] connectors removed, now referred to as footprints or denoted as “not populated”.
1.12	Mar.08.24	16, 21-23, 25-26, 28	Updated J61 description Updated section 5.4.2 for more description Updated * text on table 11,13,14,16,17
1.13	May.28.24	5-6,18- 21,24,37	Updated Section 1, Section 5.2, Section 10, Figure 1. Updated Arduino description
1.14	Jan.31.25	28	Updated the description for the I ² C/I3C pull-up resistors.
1.15	Oct.31.25	32	Switched Column 2 and 3 headings in table 25
1.16	May.13.26	19	Corrected Table 4 for J9, Debug in.

EK-RA8M1 v1 – User's Manual

Publication Date: May.13.26

Published by: Renesas Electronics Corporation

EK-RA8M1 v1 – User's Manual