

To our customers,

Old Company Name in Catalogs and Other Documents

On April 1st, 2010, NEC Electronics Corporation merged with Renesas Technology Corporation, and Renesas Electronics Corporation took over all the business of both companies. Therefore, although the old company name remains in this document, it is a valid Renesas Electronics document. We appreciate your understanding.

Renesas Electronics website: <http://www.renesas.com>

April 1st, 2010
Renesas Electronics Corporation

Issued by: Renesas Electronics Corporation (<http://www.renesas.com>)

Send any inquiries to <http://www.renesas.com/inquiry>.

Notice

1. All information included in this document is current as of the date this document is issued. Such information, however, is subject to change without any prior notice. Before purchasing or using any Renesas Electronics products listed herein, please confirm the latest product information with a Renesas Electronics sales office. Also, please pay regular and careful attention to additional and different information to be disclosed by Renesas Electronics such as that disclosed through our website.
2. Renesas Electronics does not assume any liability for infringement of patents, copyrights, or other intellectual property rights of third parties by or arising from the use of Renesas Electronics products or technical information described in this document. No license, express, implied or otherwise, is granted hereby under any patents, copyrights or other intellectual property rights of Renesas Electronics or others.
3. You should not alter, modify, copy, or otherwise misappropriate any Renesas Electronics product, whether in whole or in part.
4. Descriptions of circuits, software and other related information in this document are provided only to illustrate the operation of semiconductor products and application examples. You are fully responsible for the incorporation of these circuits, software, and information in the design of your equipment. Renesas Electronics assumes no responsibility for any losses incurred by you or third parties arising from the use of these circuits, software, or information.
5. When exporting the products or technology described in this document, you should comply with the applicable export control laws and regulations and follow the procedures required by such laws and regulations. You should not use Renesas Electronics products or the technology described in this document for any purpose relating to military applications or use by the military, including but not limited to the development of weapons of mass destruction. Renesas Electronics products and technology may not be used for or incorporated into any products or systems whose manufacture, use, or sale is prohibited under any applicable domestic or foreign laws or regulations.
6. Renesas Electronics has used reasonable care in preparing the information included in this document, but Renesas Electronics does not warrant that such information is error free. Renesas Electronics assumes no liability whatsoever for any damages incurred by you resulting from errors in or omissions from the information included herein.
7. Renesas Electronics products are classified according to the following three quality grades: “Standard”, “High Quality”, and “Specific”. The recommended applications for each Renesas Electronics product depends on the product’s quality grade, as indicated below. You must check the quality grade of each Renesas Electronics product before using it in a particular application. You may not use any Renesas Electronics product for any application categorized as “Specific” without the prior written consent of Renesas Electronics. Further, you may not use any Renesas Electronics product for any application for which it is not intended without the prior written consent of Renesas Electronics. Renesas Electronics shall not be in any way liable for any damages or losses incurred by you or third parties arising from the use of any Renesas Electronics product for an application categorized as “Specific” or for which the product is not intended where you have failed to obtain the prior written consent of Renesas Electronics. The quality grade of each Renesas Electronics product is “Standard” unless otherwise expressly specified in a Renesas Electronics data sheets or data books, etc.
 - “Standard”: Computers; office equipment; communications equipment; test and measurement equipment; audio and visual equipment; home electronic appliances; machine tools; personal electronic equipment; and industrial robots.
 - “High Quality”: Transportation equipment (automobiles, trains, ships, etc.); traffic control systems; anti-disaster systems; anti-crime systems; safety equipment; and medical equipment not specifically designed for life support.
 - “Specific”: Aircraft; aerospace equipment; submersible repeaters; nuclear reactor control systems; medical equipment or systems for life support (e.g. artificial life support devices or systems), surgical implantations, or healthcare intervention (e.g. excision, etc.), and any other applications or purposes that pose a direct threat to human life.
8. You should use the Renesas Electronics products described in this document within the range specified by Renesas Electronics, especially with respect to the maximum rating, operating supply voltage range, movement power voltage range, heat radiation characteristics, installation and other product characteristics. Renesas Electronics shall have no liability for malfunctions or damages arising out of the use of Renesas Electronics products beyond such specified ranges.
9. Although Renesas Electronics endeavors to improve the quality and reliability of its products, semiconductor products have specific characteristics such as the occurrence of failure at a certain rate and malfunctions under certain use conditions. Further, Renesas Electronics products are not subject to radiation resistance design. Please be sure to implement safety measures to guard them against the possibility of physical injury, and injury or damage caused by fire in the event of the failure of a Renesas Electronics product, such as safety design for hardware and software including but not limited to redundancy, fire control and malfunction prevention, appropriate treatment for aging degradation or any other appropriate measures. Because the evaluation of microcomputer software alone is very difficult, please evaluate the safety of the final products or system manufactured by you.
10. Please contact a Renesas Electronics sales office for details as to environmental matters such as the environmental compatibility of each Renesas Electronics product. Please use Renesas Electronics products in compliance with all applicable laws and regulations that regulate the inclusion or use of controlled substances, including without limitation, the EU RoHS Directive. Renesas Electronics assumes no liability for damages or losses occurring as a result of your noncompliance with applicable laws and regulations.
11. This document may not be reproduced or duplicated, in any form, in whole or in part, without prior written consent of Renesas Electronics.
12. Please contact a Renesas Electronics sales office if you have any questions regarding the information contained in this document or Renesas Electronics products, or if you have any other inquiries.

(Note 1) “Renesas Electronics” as used in this document means Renesas Electronics Corporation and also includes its majority-owned subsidiaries.

(Note 2) “Renesas Electronics product(s)” means any product developed or manufactured by or for Renesas Electronics.

H8S Family

Simultaneous Startup of DTC, DMAC, and CPU

Introduction

Starts up DTC, DMAC, and CPU each time a compare match occurs. DTC transfers data from the ROM to the I/O port and outputs pulses. The DMAC transfers data stored in RAM1 to RAM2. The CPU monitors the state of the port and stops DTC and DMAC when the port output goes high.

Target Device

H8S/2339

Contents

1. Specifications	2
2. Description of Functions	3
3. Principles of Operation.....	4
4. Description of Software.....	5
5. PAD.....	7
6. Link Address Specifications	8

1. Specifications

1. As shown in figure 1, this sample task starts up DTC, DMAC, and CPU each time a timer compare match occurs. DTC transfers data to I/O Port from the data table (ROM) to output the pulses. The DMAC transfers 512-byte data stored in RAM1 to RAM2. The CPU monitors the state of the port. When the port goes high, the CPU stops DTC and DMAC transfer. An interrupt to the CPU continues to be enabled.
2. Data to be transferred by the DMAC is stored in addresses H'FF8C00 to H'FF8DFF.
3. The H8S/2339 runs at 19.6608-MHz internal operating frequency.

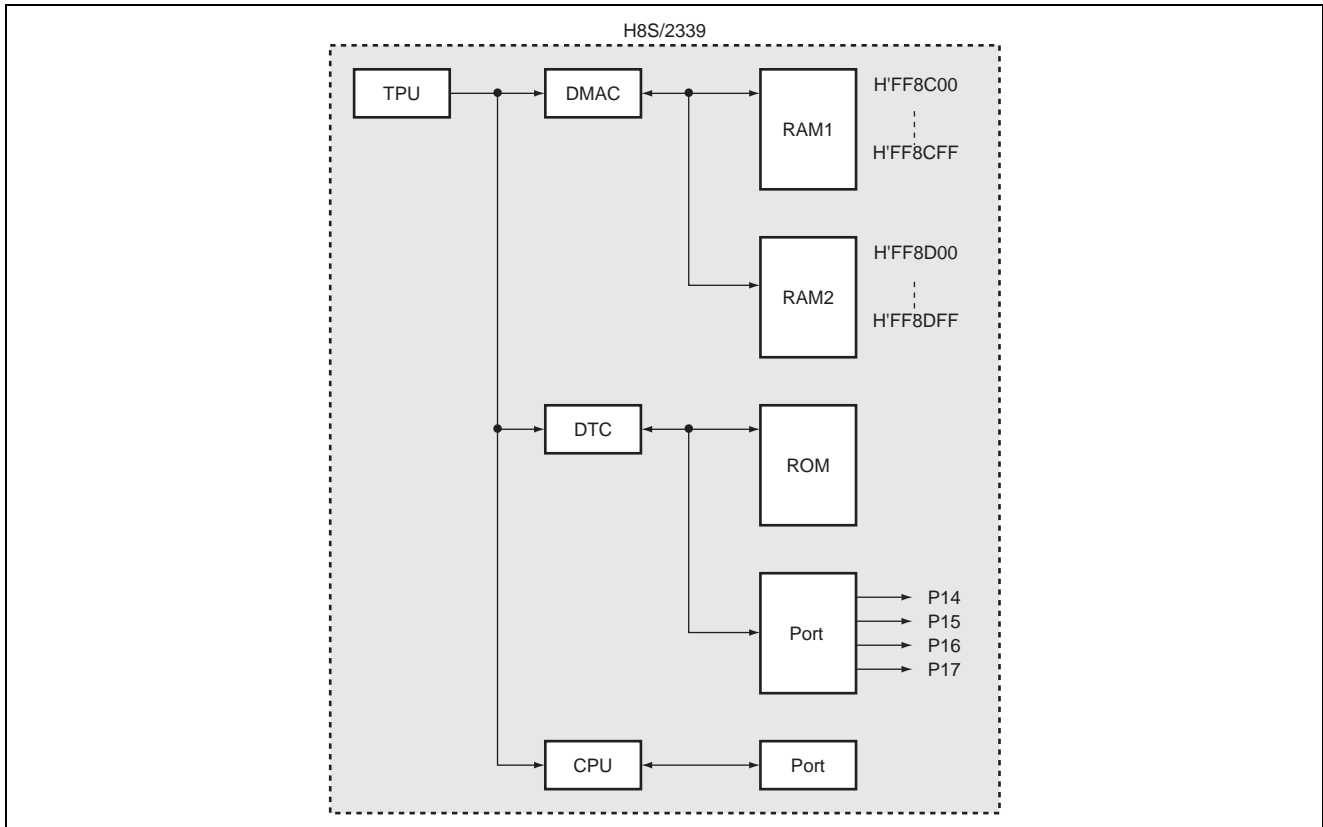

Figure 1 Block Diagram of Simultaneous Startup of DTC, DMAC, and CPU

2. Description of Functions

1. This sample task starts up the DMAC, DTC, and CPU each time a TPU compare match occurs.

A. The block diagram of H8S/2339 internal functions that this sample task uses is shown in figure 2.

This sample task uses the following functions to start up DTC, DMAC, and CPU simultaneously to transfer data and monitor the port.

[TPU]

Generates a compare match to generate a transfer request to DTC and DMAC and a CPU interrupt request.

[DMAC]

Starts up by a TPU compare match to transfer 256-byte data to RAM2 from RAM1.

[DTC], [PORT]

Start up by a TPU compare match to transfer 4-byte data to I/O port from the data table.

[CPU]

Executes interrupt processing by a TPU compare match. During interrupt processing, monitors the port state and controls DMAC and DTC transfer.

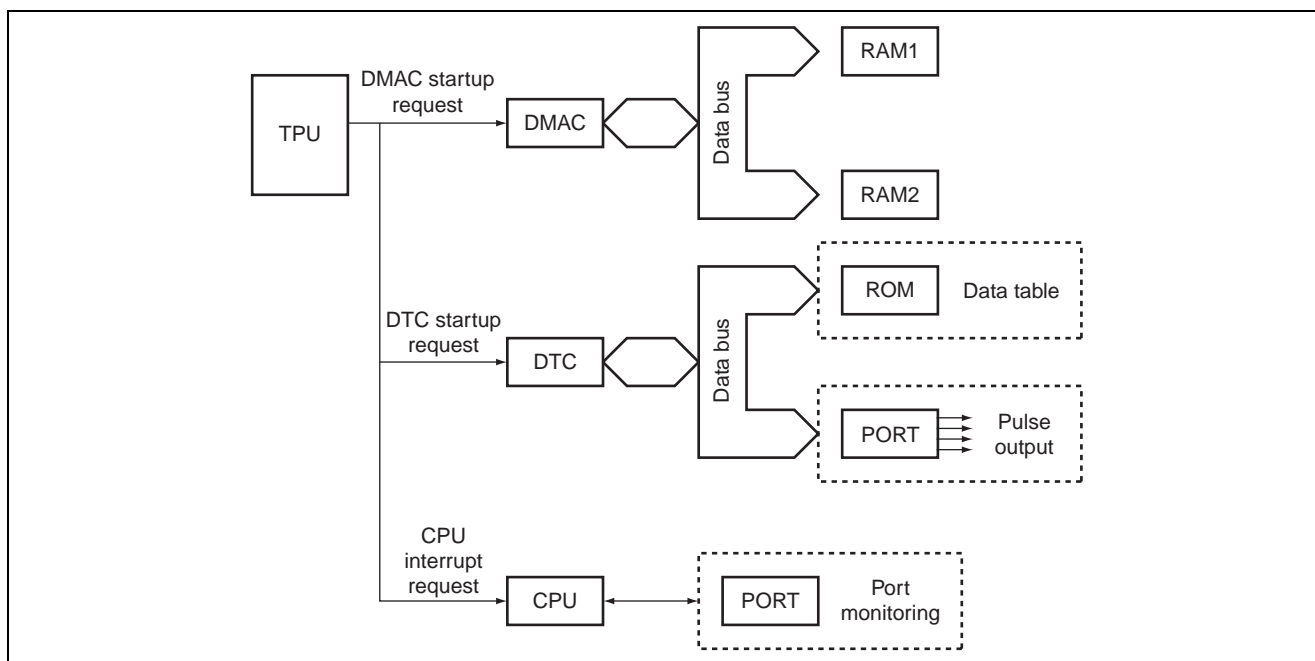

Figure 2 Block Diagram of Simultaneous Startup of DTC, DMAC, and CPU

3. Principles of Operation

The principles of operations used are shown in figure 3. This sample task performs hardware and software processing at the timing shown in figure 3 to request simultaneous startup of DTC, DMAC, and CPU interrupt.

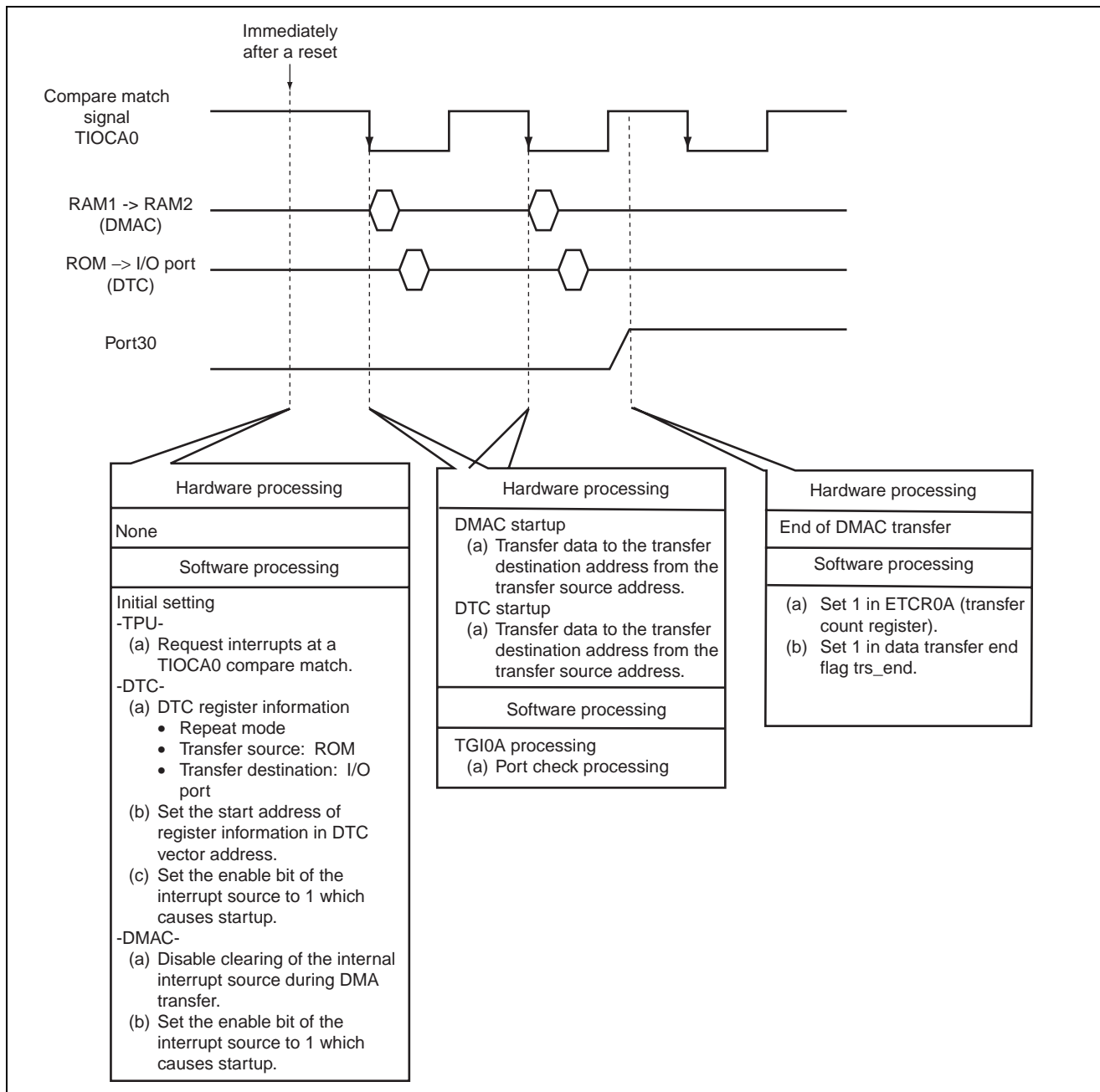

Figure 3 Principles of Operations Used of Simultaneous Startup of DTC, DMAC, and CPU

4. Description of Software

1. Description of Modules

Module Name	Label Name	Function
Main routine	simbsrnm	Performs initial setting of the TPU, DTC, DMAC, I/O port and interrupt processing.
Port check	portchk	Checks the port and performs transfer disable processing.
Data transfer end	trsend	Sets the data transfer end flag.

2. Description of Arguments

Elements	Function	Data Length	Used in	I/O
status	Indicates the state of port 30. 0: Transfer enabled 1: Data transfer disabled	unsigned char	Port check	Output
trs_end	Flag indicating the end of 256-byte transfer 0: Transfer enabled 1: Data transfer disabled	unsigned char	Data transfer end	Output

3. Description of Internal Registers Used

Implemented Function	Register Name	Function
DMAC	DMABCR	Sets the DMAC0A as follows: <ul style="list-style-type: none"> • Full-address mode as the transfer mode • Disabling clear of the internal interrupt source during DMA transfer • Enabling data transfer and a transfer end interrupt
	DMACR0A	Sets the DMAC0A as follows: <ul style="list-style-type: none"> • Byte size as the data size • MAR increment • Block transfer mode for data transfer, and block area is set on the destination side • Setting the startup source to TPU0A
	MAR0A	Sets the start address (trs) of RAM1.
	MAR0B	Sets the start address (rev) of RAM2.
	ETCR0A, OB	Sets the transfer count.
	TPU	TCR0
TIOR0		Enables compare match output.
TIER0		Enables a compare match interrupt.
TSR0		Sets the TGRA capture interrupt request flag.
TGR0A		Set the compare-match counter value in TGR0A.
TSTR		Startup the TPU0 counter.
DTC		DT CER
MSTPCR		Controls module stop mode of DTC, TPU and DMAC.

4. RAM Usage

Table below describes RAM usage in this sample task.

Elements	Function	Data Length	Used in
MAR0	Sets the DTC0 in the repeat mode.	unsigned char	Main routine
MRB0	Enables an interrupt to the CPU.	unsigned char	
SAR0	Sets the transfer source address (PATTBL1).	unsigned long	
DAR0	Sets the transfer destination address (P07 to P04).	unsigned long	
CRA0	Sets the transfer count.	unsigned short	
trs	Stores transmit data.	256 bytes	
rev	Stores received data.	256 bytes	
PATTBL1	Stores pulse output data.	4 bytes	

5. PAD

1. Main Routine

<div style="border: 1px solid black; padding: 2px; display: inline-block;">Simultaneous startup</div> simbsrmm	Initialize status flag and trs_end flag.
	Cancel the TPU, DMA, and DTC module stop mode.
	Set port 2 to output.
	Using "next data enable L register", set pulse pins PO7 to PO0 to output.
	Initialize "output data register".
	Set PPG pulse output groups 3 to 0 to operate at TPU0 compare-match.
	Set PPG output mode register so that PPG pulse output groups 3 to 0 outputs are not inverted.
	Set DMAC to full address mode and to disable clearing of internal interrupt sources
	Set the transfer source address (MAR0A) to RAM1 start address.
	Set the transfer destination address (MAR0B) to RAM2 start address.
	Set the number of transfer to 256 times.
	Set transfer in block transfer mode, the block area on the transfer destination side, byte size, and to increment MARA after data transfer.
	After data transfer, increment MARB, and startup following interrupt by TPU0 compare match.
	Set the DTME bit to enable data transfer of channel 0.
	Set the DTE bit of DMAC to enable data transfer of channel 0.
	Set the DTIEA bit to enable transfer end interrupts on channel 0.
	Set the DTIEB bit to enable transfer-suspend interrupts on channel 0.
	Set the start address of the transfer source PATTBL1 in SAR0.
	Set the start address of the transfer destination PPG.NDRL1 in DAR0.
	Increment SAR after transfer, DAR is fixed, and transfer in repeat mode on the transfer source side.
	After DTC data transfer is completed, enable interrupts to the CPU.
	Set the number of data transfers by the DTC to 04.
	Set the DTC startup enable bit to startup by the TG10A interrupt.
	Output 1 by compare match of the output compare register.
	Set the count value to be used for compare matching in TGRA.
	Clear TCNT by TGRA compare match.
	Enable TGIA interrupts.
	Clear the I flag and enable interrupts.
	Enable TPU0 count operation.
	while (1)

2. Port Check

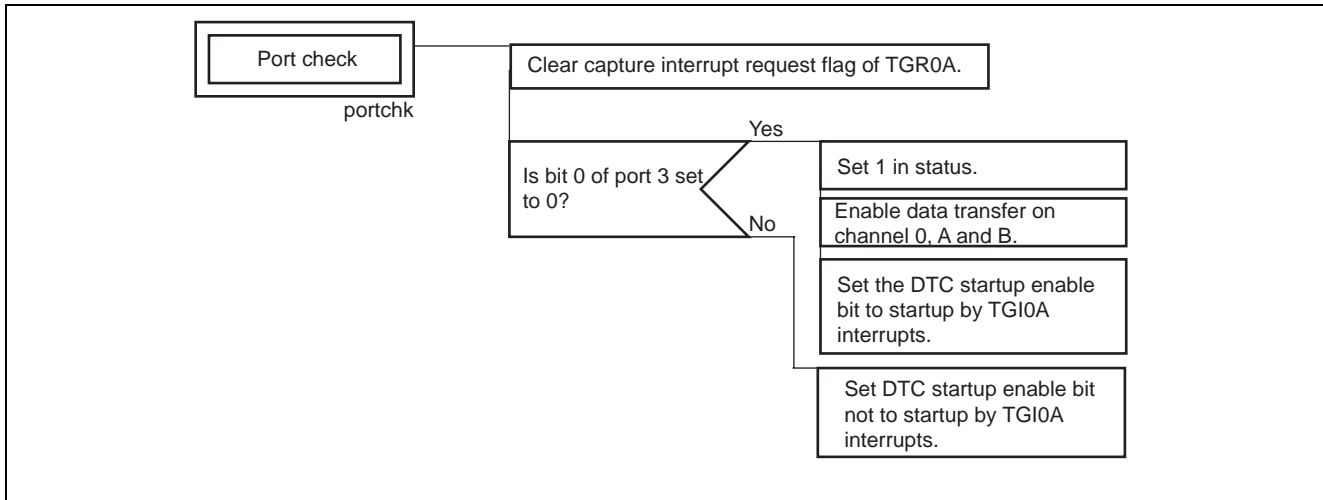

3. Data Transfer End

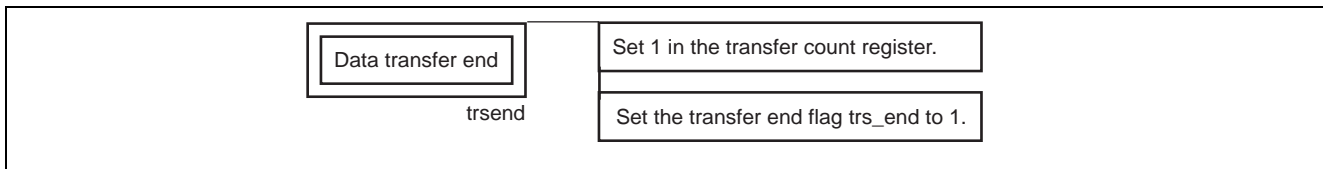

6. Link Address Specifications

Section Name	Address
dDtc_vect_TGI0A	H'00000400
PResetPRG, PIntPRG, P, C, C\$DSEC, C\$BSEC, D	H'00000800
B, R	H'00FFDC00
S	H'00FFF9F0

Revision Record

Rev.	Date	Description	
		Page	Summary
1.00	Feb.17.05	—	First edition issued

Keep safety first in your circuit designs!

1. Renesas Technology Corp. puts the maximum effort into making semiconductor products better and more reliable, but there is always the possibility that trouble may occur with them. Trouble with semiconductors may lead to personal injury, fire or property damage.
Remember to give due consideration to safety when making your circuit designs, with appropriate measures such as (i) placement of substitutive, auxiliary circuits, (ii) use of nonflammable material or (iii) prevention against any malfunction or mishap.

Notes regarding these materials

1. These materials are intended as a reference to assist our customers in the selection of the Renesas Technology Corp. product best suited to the customer's application; they do not convey any license under any intellectual property rights, or any other rights, belonging to Renesas Technology Corp. or a third party.
2. Renesas Technology Corp. assumes no responsibility for any damage, or infringement of any third-party's rights, originating in the use of any product data, diagrams, charts, programs, algorithms, or circuit application examples contained in these materials.
3. All information contained in these materials, including product data, diagrams, charts, programs and algorithms represents information on products at the time of publication of these materials, and are subject to change by Renesas Technology Corp. without notice due to product improvements or other reasons. It is therefore recommended that customers contact Renesas Technology Corp. or an authorized Renesas Technology Corp. product distributor for the latest product information before purchasing a product listed herein.
The information described here may contain technical inaccuracies or typographical errors.
Renesas Technology Corp. assumes no responsibility for any damage, liability, or other loss rising from these inaccuracies or errors.
Please also pay attention to information published by Renesas Technology Corp. by various means, including the Renesas Technology Corp. Semiconductor home page (<http://www.renesas.com>).
4. When using any or all of the information contained in these materials, including product data, diagrams, charts, programs, and algorithms, please be sure to evaluate all information as a total system before making a final decision on the applicability of the information and products. Renesas Technology Corp. assumes no responsibility for any damage, liability or other loss resulting from the information contained herein.
5. Renesas Technology Corp. semiconductors are not designed or manufactured for use in a device or system that is used under circumstances in which human life is potentially at stake. Please contact Renesas Technology Corp. or an authorized Renesas Technology Corp. product distributor when considering the use of a product contained herein for any specific purposes, such as apparatus or systems for transportation, vehicular, medical, aerospace, nuclear, or undersea repeater use.
6. The prior written approval of Renesas Technology Corp. is necessary to reprint or reproduce in whole or in part these materials.
7. If these products or technologies are subject to the Japanese export control restrictions, they must be exported under a license from the Japanese government and cannot be imported into a country other than the approved destination.
Any diversion or reexport contrary to the export control laws and regulations of Japan and/or the country of destination is prohibited.
8. Please contact Renesas Technology Corp. for further details on these materials or the products contained therein.