

# Electric Toothbrush

## SLG47513

This application note describes how to use the SLG47513 to implement an electric toothbrush. The application note comes complete with design files, which can be found in the References section.

## Contents

1. Introduction .....	2
2. GreenPAK Design .....	2
2.1 Motor Control .....	3
2.2 Charging .....	4
2.3 Simulation of Project .....	6
3. Conclusions .....	6
4. Revision History .....	7

## References

For related documents and software, please visit:

<https://www.renesas.com/eu/en/products/programmable-mixed-signal-asic-ip-products/greenpak-programmable-mixed-signal-products>

Download our free GreenPAK Designer software [1] to open the .gp file [2] and view the proposed circuit design. Use the GreenPAK development tools [3] to freeze the design into your own customized IC in a matter of minutes. Renesas Electronics provides a complete library of application notes [4] featuring design examples, as well as explanations of features and blocks within the Renesas IC.

[1] [GreenPAK Go Configure Software Hub](#), Software Download and User Guide, Renesas Electronics

[2] [AN-CM-360 Electric Toothbrush.gp6](#), GreenPAK Design File, Renesas Electronics

[3] [GreenPAK Development Tools](#), GreenPAK Development Tools Webpage, Renesas Electronics

[4] [GreenPAK Application Notes](#), GreenPAK Application Notes Webpage, Renesas Electronics

# Electric Toothbrush

## 1. Introduction

The global population increasingly prioritizes oral health and hygiene. This factor is driving the utilization of toothbrushes across the world. Electric toothbrushes enhance the brushing experience and brushing habits. The most popular and effective type of electric toothbrush is one with a rotating or side-to-side movement. Motions at sonic speeds or lower are made with the help of a motor.

Modern electric toothbrushes typically rely on rechargeable batteries, which are charged through inductive charging when the toothbrush is placed in a charging base between uses. They often use nickel-metal hydride (NiMH) batteries, whose nominal voltage is 1.2 V. The SLG47513 has a working voltage range from 1 V to 1.65 V, enabling control over the toothbrush's operation.

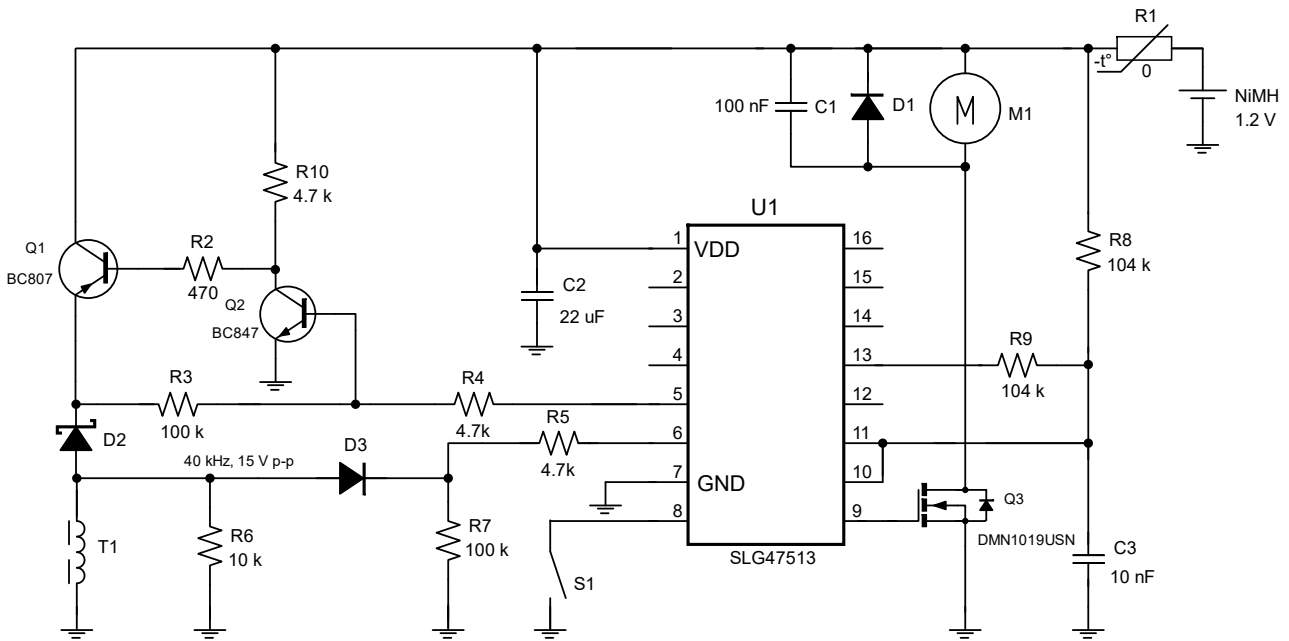

Figure 1. General Schematic of Electric Toothbrush Based on SLG47513

## 2. GreenPAK Design

Figure 2 shows an internal design of the electric toothbrush in the GreenPAK Designer software.

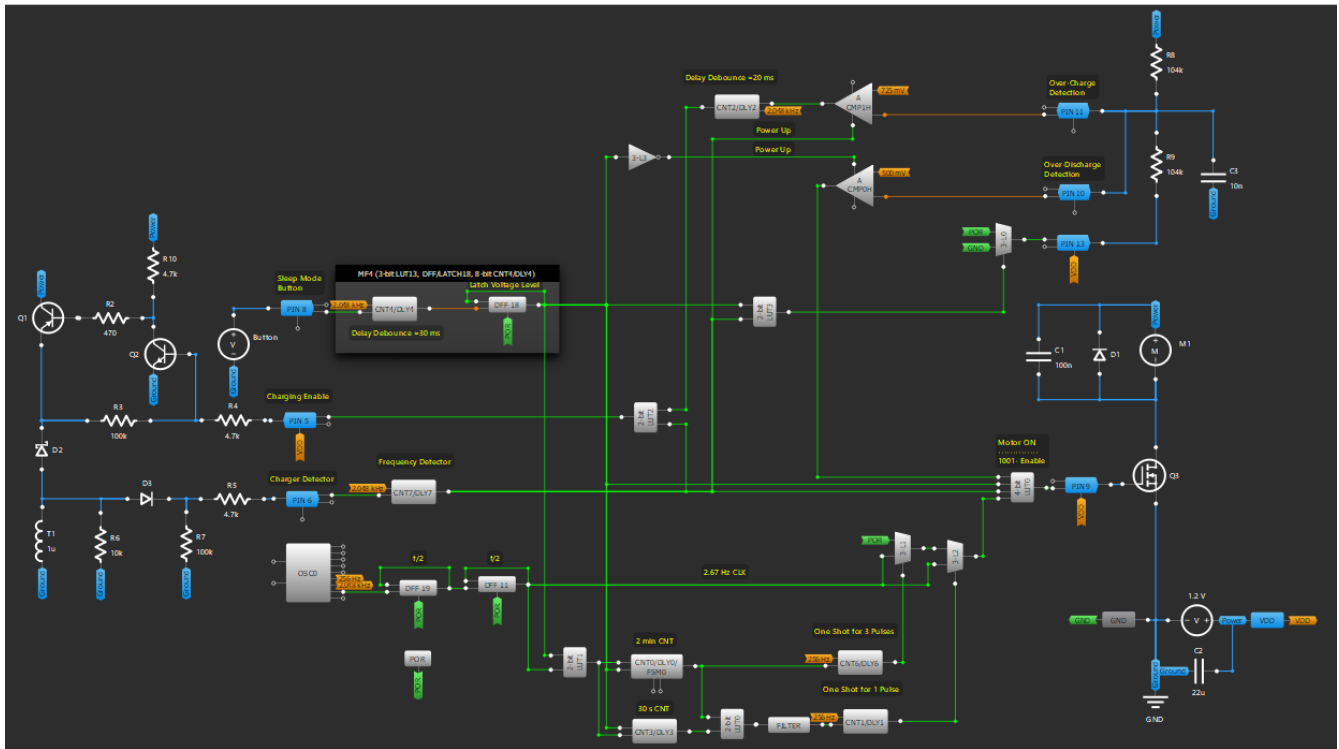

Figure 2. Electric Toothbrush GreenPAK Designer Schematic

## 2.1 Motor Control

When the toothbrush is in sleep mode, Pin 8 output is set to HIGH due to a pull-up resistor, but when a button is pressed, a low-level signal appears for a brief period. To filter out switch bouncing, a Delay macrocell DLY4 is used. A DFF18 latches the voltage level and flips it each time the button is pressed, allowing the toothbrush to switch between two modes using an external button – working mode and sleep mode.

When the toothbrush is switched to the working mode, there is a constant HIGH voltage level at a gate of a transistor, as well as at the output of a multiplexer 3-L2. This voltage level opens the transistor Q3 and starts a DC motor.

The brush has 2 timers. The first one informs the user about the completion of a 2-minute brushing session. An oscillator OSC0, a DFF19, and a DFF11 form a clock signal with a frequency of 2.67 Hz. When the toothbrush is switched to ON mode, a 2-bit LUT1 feeds this clock signal to the CLK input of a CNT0. After two minutes have passed, a HIGH level appears at the CNT0 output, which triggers a one-shot (CNT6), forming a signal pulse with a width equal to three and a half periods of the clock signal. These three pulses, through two multiplexers, 3-bit LUT0, and Pin 9 are fed to the transistor gate and, accordingly, to the motor, creating a vibration effect (see [Figure 3](#) and [Figure 4a](#)).

In addition to the 2-minute timer, this toothbrush also contains a 30-second timer based on a CNT3, which signals the need to proceed with brushing the next quadrant (quarter) of the oral cavity. After 30 seconds have passed, a HIGH level appears at the CNT3 output. A 2-bit LUT0 filters every 4th pulse, and a Filter macrocell eliminates glitches. The CNT3 output signal triggers a one-shot (CNT1), which forms a signal pulse with a width equal to one and a half periods of the clock signal (see [Figure 3](#) and [Figure 4b](#)).

To ensure that the timers are restarted each time the toothbrush is turned off, the counters are reset on the rising edge of the DFF18 output signal.

Digital multiplexers enable the passage of either a constant voltage, one pulse, or three pulses to the transistor gate based on the one-shots outputs.

# Electric Toothbrush

The 3-bit LUT0 prevents the motor from running while charging. Specifically, a signal on the transistor gate is HIGH only when the toothbrush is in working mode and not placed in the charging station.



Figure 3 Waveforms that Illustrate Work of Toothbrush during One Brushing Session

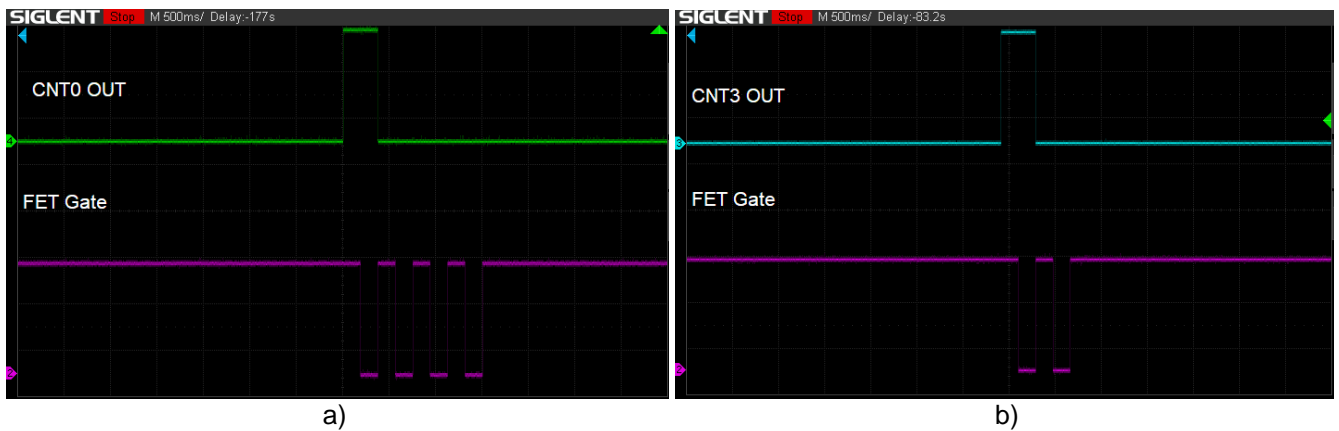

Figure 4. Signals Informing about Completion a) 2-minute Total Brushing; b) 30-second Quadrant Brushing

## 2.2 Charging

Most modern electric toothbrushes use wireless inductive charging. The toothbrush and its base form a two-part transformer, with the base having the primary winding of the transformer and the toothbrush having the secondary winding. The voltage induced on the secondary winding is rectified by a diode D1 and then reduced by a resistive divider to the value required for proper detection of the presence of a charger (see Figure 1). The divider comprises external resistors R7 (100 kΩ) and R5 (4.7 kΩ), and an internal pull-down resistor (10 kΩ) inside the SLG47513, which sets the peak value of the voltage on Pin 6 at around 1.2 V.

When the signal from the charger reaches Pin 6, which functions as an analog comparator, a HIGH level appears at the input of a frequency detector. The frequency detector generates a high-level output on this signal, which

# Electric Toothbrush

goes to Pin 5 and enables charging (see Figure 5 and Figure 6). This high-level signal at the output of Pin 5 opens a Q2 transistor, which, in turn, opens a Q1 transistor, initiating the charging process of the battery.

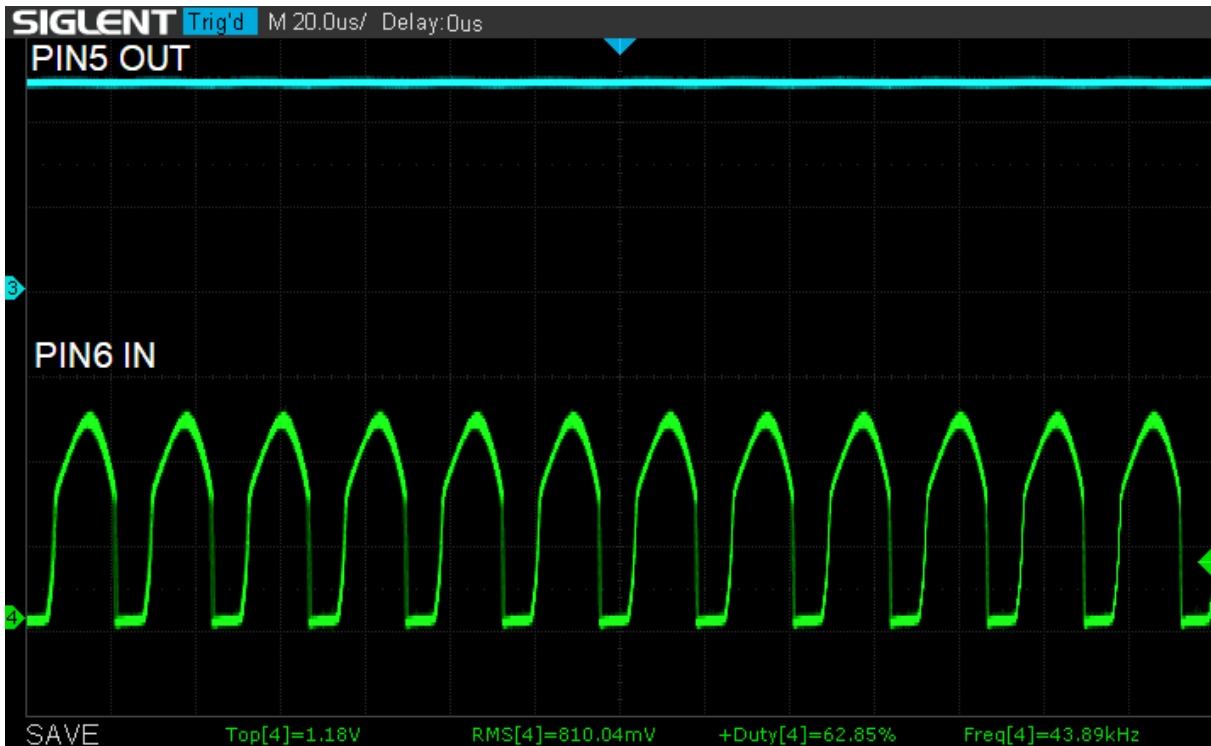

Figure 5 Signal from Charger at Input of Pin 6 and Output Enable at Pin 5

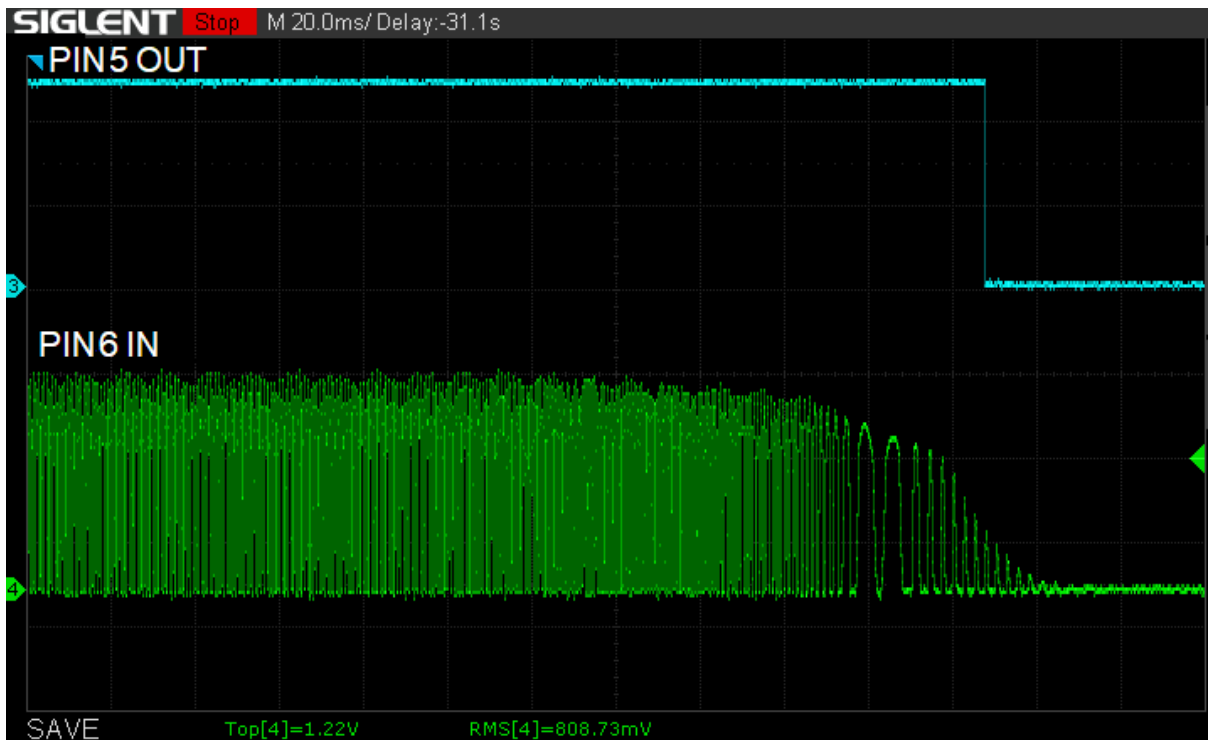

Figure 6 Signals at Input of Pin 6 and Output of Pin 5 during the Process of Disconnecting Charger

To protect the battery against overcharging, an analog comparator ACMP1H is used. Resistors R8 and R9 divide the battery voltage in half, and this voltage is applied to the input of Pin 11. Then it is compared with a reference voltage of 725 mV by a comparator with a hysteresis of 100 mV. If the voltage from the divider reaches this reference voltage, the battery charging stops. A Delay macrocell DLY2 as a filter is used.

## Electric Toothbrush

---

To protect the battery against over-discharging, an analog comparator ACMP0H is used. This comparator compares the same voltage from the divider but has its reference voltage set at 500 mV and hysteresis at 100 mV. When the measured voltage becomes less than the reference, the comparator output goes LOW and the transistor closes, preventing the battery from over-discharging.

To prevent the circuit from consuming excess energy through the divider, the divider is connected to the ground bus only when the battery is charging or when the toothbrush is on. These conditions are checked by a 2-bit LUT3 and its output goes HIGH when at least one of the conditions is met. A multiplexer 3-L0, based on this high-level signal, connects the ground bus to the divider through an open-collector transistor of Pin13. Additionally, ACMP0H is powered on only when the toothbrush comes out of sleep mode, and ACMP1H is powered on only when the charger is connected. These measures ensure extremely low consumption in sleep mode.

### 2.3 Simulation of Project

The motor control part of the project can be simulated in the GreenPAK Designer Software Simulation Tool.

## 3. Conclusions

The SLG47513 is a low-voltage GreenPAK IC. Its low-voltage operation allows the project to be supplied by just one 1.2 V NiMH battery, which is the primary power source for electric toothbrushes. The SLG47513 is a perfect fit for these devices as it has a sufficient number of digital and analog macrocells that can be used to control the toothbrush motor and implement additional features such as timers and charging control. The SLG47513 can serve as a functional replacement for popular electric toothbrushes available in the market. Because there are not many integrated circuits available in the market that can be powered by 1.2 V and can implement toothbrush functionalities, manufacturers often use custom ASICs, which increases the cost of the toothbrush. GreenPAK is a cost-effective solution as it uses an off-the-shelf base die and comes in an extremely small case of 1.6 mm x 1.6 mm, which helps to reduce the board space required.

## 4. Revision History

Revision	Date	Description
1.00	May 24, 2023	Initial release.

## IMPORTANT NOTICE AND DISCLAIMER

RENESAS ELECTRONICS CORPORATION AND ITS SUBSIDIARIES (“RENESAS”) PROVIDES TECHNICAL SPECIFICATIONS AND RELIABILITY DATA (INCLUDING DATASHEETS), DESIGN RESOURCES (INCLUDING REFERENCE DESIGNS), APPLICATION OR OTHER DESIGN ADVICE, WEB TOOLS, SAFETY INFORMATION, AND OTHER RESOURCES “AS IS” AND WITH ALL FAULTS, AND DISCLAIMS ALL WARRANTIES, EXPRESS OR IMPLIED, INCLUDING, WITHOUT LIMITATION, ANY IMPLIED WARRANTIES OF MERCHANTABILITY, FITNESS FOR A PARTICULAR PURPOSE, OR NON-INFRINGEMENT OF THIRD-PARTY INTELLECTUAL PROPERTY RIGHTS.

These resources are intended for developers who are designing with Renesas products. You are solely responsible for (1) selecting the appropriate products for your application, (2) designing, validating, and testing your application, and (3) ensuring your application meets applicable standards, and any other safety, security, or other requirements. These resources are subject to change without notice. Renesas grants you permission to use these resources only to develop an application that uses Renesas products. Other reproduction or use of these resources is strictly prohibited. No license is granted to any other Renesas intellectual property or to any third-party intellectual property. Renesas disclaims responsibility for, and you will fully indemnify Renesas and its representatives against, any claims, damages, costs, losses, or liabilities arising from your use of these resources. Renesas' products are provided only subject to Renesas' Terms and Conditions of Sale or other applicable terms agreed to in writing. No use of any Renesas resources expands or otherwise alters any applicable warranties or warranty disclaimers for these products.

(Disclaimer Rev.1.01)

### Corporate Headquarters

TOYOSU FORESIA, 3-2-24 Toyosu,  
Koto-ku, Tokyo 135-0061, Japan  
[www.renesas.com](http://www.renesas.com)

### Trademarks

Renesas and the Renesas logo are trademarks of Renesas Electronics Corporation. All trademarks and registered trademarks are the property of their respective owners.

### Contact Information

For further information on a product, technology, the most up-to-date version of a document, or your nearest sales office, please visit [www.renesas.com/contact-us/](http://www.renesas.com/contact-us/).