

Application Note

Self-Powered Solar Tracking Sensor

AN-CM-252

Abstract

The application note will present the design of a simple self-powered solar tracking sensor circuit based upon the Dialog Semiconductors products, i.e. the Dialog Semiconductors operational amplifier. The circuitry uses only the energy obtained from the photodetectors, i.e. the sensors. This application note comes complete with design files which can be found in the References section.

Self-Powered Solar Tracking Sensor

Contents

Abstract.....	1
Contents.....	2
Figures.....	2
1 Terms and Definitions.....	3
2 References.....	3
3 Introduction.....	4
4 The Sensor Circuitry.....	4
5 Realization with SLG88103 Operational Amplifiers.....	6
6 Example Implementation.....	8
7 Conclusion.....	10
Revision History.....	11

Figures

Figure 1: Schematic of the Simple Self-Powered Solar Tracking Sensor Circuitry.....	5
Figure 2: Measurement of the Position of the Sun with Respect to the Sensor.....	6
Figure 3: Schematic of the Simulated Circuitry.....	7
Figure 4: Simulation Results of the Proposed Circuitry.....	8
Figure 5: Photo of the Test Board Together with the Sensor.....	9
Figure 6: Transfer Function of the Sensor Circuitry.....	10

Self-Powered Solar Tracking Sensor

1 Terms and Definitions

OP, OpAmp	Operational Amplifier
PD	Photodiode

2 References

For related documents and software, please visit:

<https://www.dialog-semiconductor.com/configurable-mixed-signal>.

Download our free [GreenPAK Designer software](#) [1] to view the proposed circuit design. Use the [GreenPAK development tools](#) [2] to freeze the design into your own customized IC in a matter of minutes. Dialog Semiconductor provides a complete library of application notes [3] featuring design examples as well as explanations of features and blocks within the Dialog IC.

- [1] [GreenPAK Designer Software](#), Software Download and User Guide, Dialog Semiconductor
- [2] [GreenPAK Development Tools](#), [GreenPAK Development Tools Webpage](#), Dialog Semiconductor
- [3] [GreenPAK Application Notes](#), [GreenPAK Application Notes Webpage](#), Dialog Semiconductor
- [4] SLG88103/4 Rail to Rail I/O 375 nA/Amp Dual/Quad CMOS Op Amps with Power Down, Datasheet, Dialog Semiconductor
- [5] BPW 34 B Silicon PIN Photodiode with Enhanced Blue Sensitivity; in SMT Version 1.6, Datasheet, OSRAM Opto Semiconductors

Self-Powered Solar Tracking Sensor

3 Introduction

This application note will present the possibility of designing a simple self-powered solar tracking sensor circuit using a Dialog Semiconductor SLG88103 operational amplifier. The complete circuitry is self-powered, since it uses only the power obtained from the photodetectors. There is no need for an additional external power supply. The photodetectors are arranged so that they can sense the direction of solar irradiance. Based upon the signal processing circuitry at the outputs, two highly sensitive voltage signals are generated. These signals correspond to the pitch and roll angles of the sun with respect to the photodiodes. The circuitry has an inherent automatic gain control. Therefore, the output signals are only proportional to these angles and not to the solar irradiation level.

4 The Sensor Circuitry

The schematic of the proposed simple self-powered solar tracking sensor circuitry is presented in [Figure 1](#). Processing the signals from the photodetectors requires only two operational amplifiers and several resistors. Additionally, as the photodetectors (photodiodes PDYU1, PDYU2, PDYD1, PDYD2, PDXR1, PDXR2, PDXL1, and PDXL2) work in the photovoltaic mode the generated power is significant enough to power the op-amps. Both the X and Y direction use four photodiodes (PDYU1, PDYU2, PDYD1, and PDYD2) connected in series to power on the operational amplifiers OP1 and OP2. The corresponding voltages, obtained at the photodiodes when in photovoltaic mode, are given by:

$$V_i = V_T \ln\left(\frac{\mathfrak{R}P_i}{I_S}\right) \quad (1)$$

where V_i is the corresponding i-th ($i = YU1, YU2, YD1, YD2, XR1, XR2, XL1, \text{ and } XL2$) photodiode voltage, V_T is the thermal voltage given by $V_T = k_B T / q$ where $k_B = 1.38 \times 10^{-23} \text{ J/K}$ is the Boltzmann constant, T is the absolute temperature, $q = 1.602 \times 10^{-19} \text{ C}$ is the elementary charge, \mathfrak{R} is the photodiode responsivity, P_i is the i-th photodiode captured optical power, and I_S is the photodiode saturation current.

To keep photodiodes in the photovoltaic mode they must be connected to the high impedance nodes, thus requiring high values of the resistance R_L . The corresponding photodiode-captured optical power depends upon the shadow position within the enclosure, i.e. it depends on the shadow distribution over the active photodiode surface. This is presented in [Figure 1](#). The actively-illuminated area on the photodiodes' surface depends upon the pitch and roll angles of the sun with respect to the photodiodes, as presented in [Figure 2](#). This is, naturally, valid only for the photodiodes that are shadowed by the enclosure. For example, if the Sun illuminates the sensor from the first quadrant, shown in [Figure 2](#), only photodiodes PDYU2 and PDXR2 will be in the shadow and their corresponding illuminated area will be:

$$A_{XR2} = A - K\xi \quad (2.1)$$

$$A_{YU2} = A - K\psi \quad (2.2)$$

where small pitch ξ and roll ψ angles were assumed ($\xi, \psi \ll 1$) thus giving, in the first approximation, the linear dependence of the illuminated photodiode area with respect to the corresponding angles, where A is the area of the photodiode active surface, K is the positive proportionality constant that depends on the sensor geometry, and where $A \gg K\xi, K\psi$ is also valid.

Self-Powered Solar Tracking Sensor

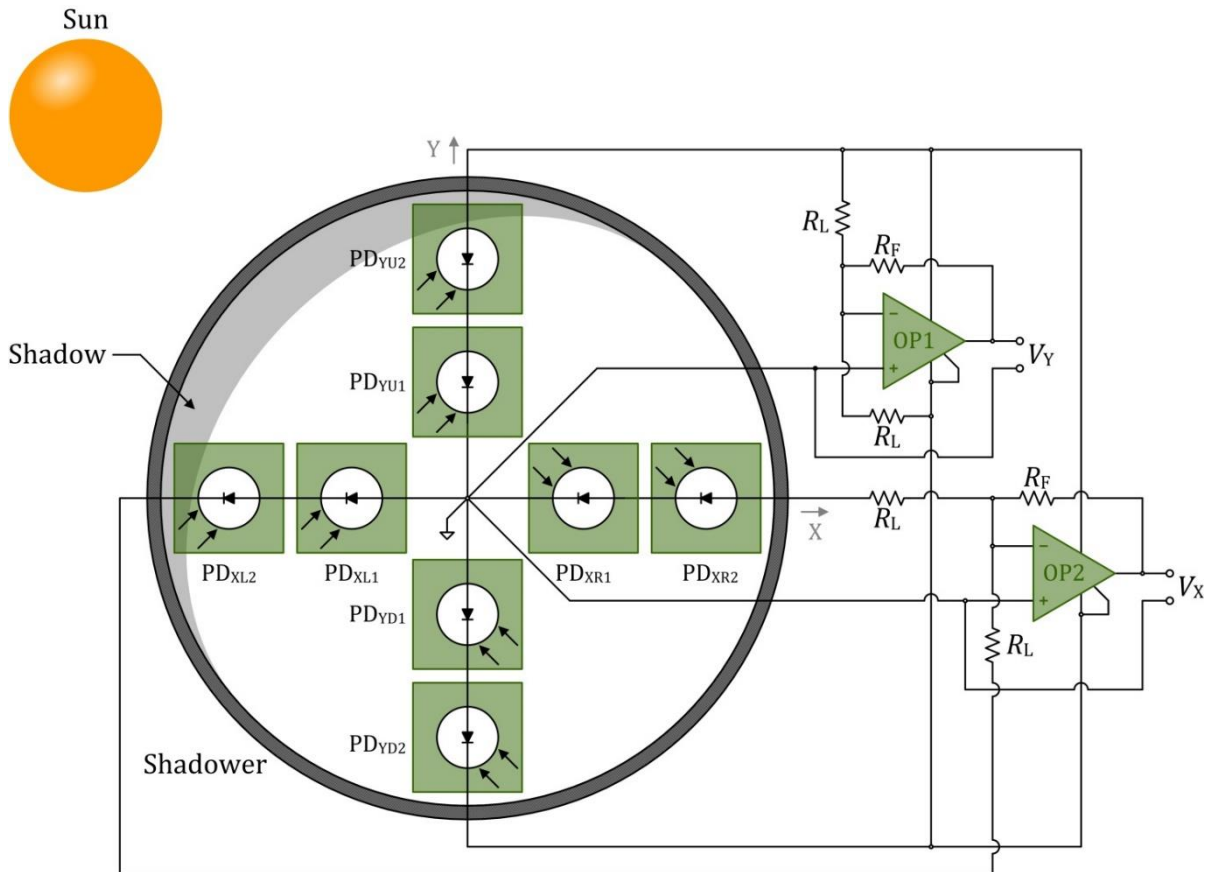

Figure 1: Schematic of the Simple Self-Powered Solar Tracking Sensor Circuitry

The corresponding photodiode voltages V_i according to equation (1) are given by:

$$V_{XR2} = V_T \ln\left(\frac{\mathfrak{R}EA_{XR2}}{I_S}\right) \quad (3.1)$$

$$V_{XR1} = V_{XL1} = V_{XL2} = V_T \ln\left(\frac{\mathfrak{R}EA}{I_S}\right) \quad (3.2)$$

$$V_{YU2} = V_T \ln\left(\frac{\mathfrak{R}EA_{YU2}}{I_S}\right) \quad (3.3)$$

$$V_{YU1} = V_{YD1} = V_{YD2} = V_T \ln\left(\frac{\mathfrak{R}EA}{I_S}\right) \quad (3.4)$$

where E is the solar irradiance. The output voltages V_X and V_Y are given as:

$$V_X = -\frac{R_F}{R_L}(V_{XR2} + V_{XR1} - V_{XL2} - V_{XL1}) \quad (4.1)$$

$$V_Y = -\frac{R_F}{R_L}(V_{YU2} + V_{YU1} - V_{YD2} - V_{YD1}) \quad (4.2)$$

where R_F is the feedback resistor resistance. Equations (2), (3), and (4) give:

$$V_X = -\frac{R_F}{R_L} V_T \ln\left(1 - \frac{K\xi}{A}\right) \approx \frac{R_F K}{R_L A} V_T \xi = S\xi \quad (5.1)$$

$$V_Y = -\frac{R_F}{R_L} V_T \ln\left(1 - \frac{K\psi}{A}\right) \approx \frac{R_F K}{R_L A} V_T \psi = S\psi \quad (5.2)$$

In the first approximation the output voltage signals V_X and V_Y are directly proportional to the pitch and roll angles with sensor sensitivity S . As the output signals are independent of the solar irradiance the circuitry has an inherent automatic gain control.

Self-Powered Solar Tracking Sensor

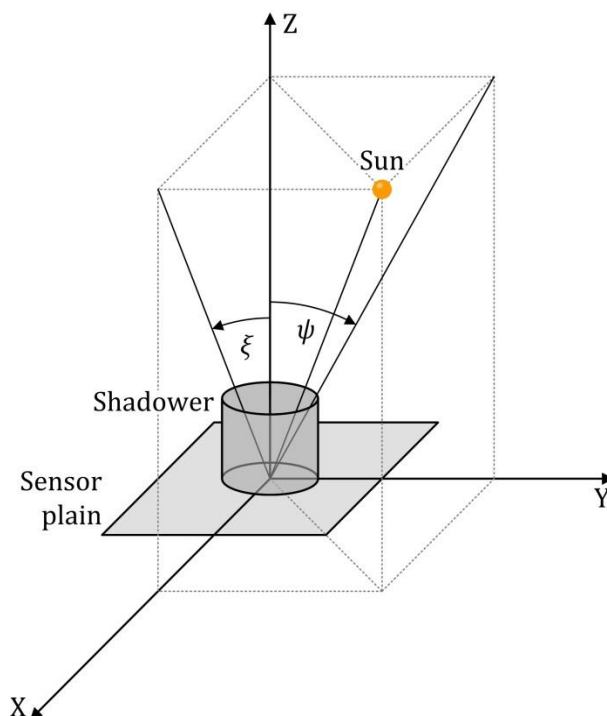

Figure 2: Measurement of the Position of the Sun with Respect to the Sensor

5 Realization with SLG88103 Operational Amplifiers

The realization of a simple self-powered solar tracking sensor circuitry will be based on the extremely low-power characteristics of the SLG88103 operational amplifiers [4]. To test the proposed circuitry a simulation in LTspice has been performed. The simulated circuitry, only for a single axis, has been presented in Figure 3. The system circuitry consists of two such sub circuitries, each aimed for sensing a single axis position of the sun. As the photodetectors, four BPW34 photodiodes from OSRAM Opto Semiconductors have been used in the simulation due to their relatively large sensing area of 7.45 mm^2 ($2.73 \text{ mm} \times 2.73 \text{ mm}$). The spice model of the photodiodes is provided by Opto Semiconductors as well [5].

Self-Powered Solar Tracking Sensor

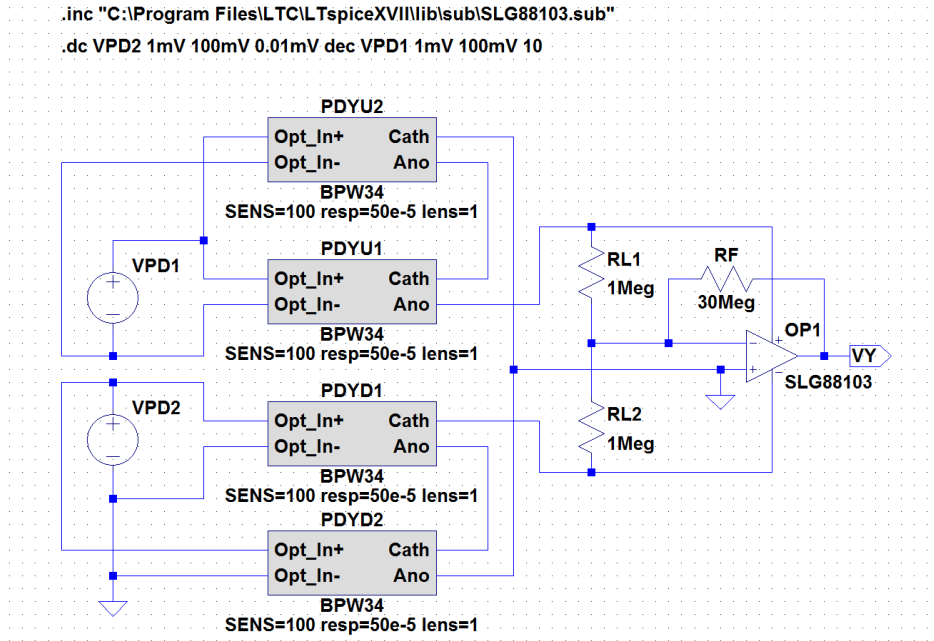

Figure 3: Schematic of the Simulated Circuitry

The solar irradiance has been modeled by two voltage sources VPD1 and VPD2, where the voltage in millivolts (mV) corresponds to the solar irradiance in mW/ cm². The solar irradiance was swept within the range of 1 mW/ cm² (1 mV) and 100 mW/cm², (100 mV), wherein 100 mW/cm² also represents the maximal possible value of the solar irradiance. As mentioned above, if the angle between the sensor surface and the Sun is not perpendicular, i.e. the pitch and roll angles are not equal to zero, due to intentional partial-shading of the photodiodes, there will be an unequal distribution of the irradiance at the photodiode surface. The unequal distribution of the solar radiation over the photodiode surfaces has been modeled with the different values of the solar irradiance, i.e. with the different values of the voltage sources VPD1 and VPD2. The corresponding simulation results are presented in Figure 4.

The conclusion, which can be drawn from the simulation results, is that the circuitry is highly sensitive to the change in the solar illumination direction, which correlates to the change of the corresponding voltages of the voltage sources VPD1 and VPD2. The important characteristic of the proposed design is that the sensor sensitivity doesn't depend on the overall illumination of the sun, provided the rail-to-rail voltage of the op-amp is greater than 1.71 V. This can be concluded from the same slopes of the sensor response in the logarithmic scale. Therefore, the sensor has inherent gain control, which is a very important feature of this sensor circuitry, especially if it has been used in the control loop where the overall system stability is of the paramount importance. The same sensor sensitivity for a broad range of the solar irradiances leads to the very simple design of the control loop.

Self-Powered Solar Tracking Sensor

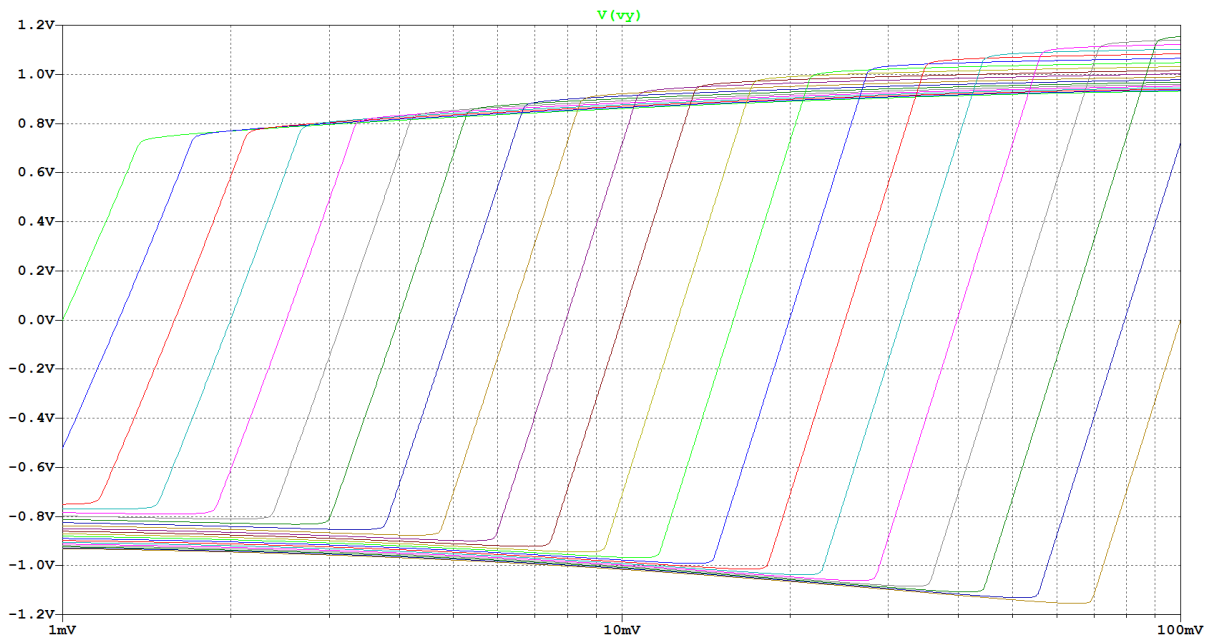

Figure 4: Simulation Results of the Proposed Circuitry

The photodiode shunt resistance R_{SH} is given as:

$$R_{SH} = \frac{V_T}{\mathfrak{R}AE} \quad (6)$$

which, in the case of the BPW34 photodiode, with $\mathfrak{R} = 0.5 \text{ A/W}$, $A = 7.45 \text{ mm}^2$ and the minimum solar irradiance of $E = 1 \text{ mW/cm}^2$, gives the maximum value of the photodiode shunt resistance of $R_{SH} \approx 670 \Omega$. To operate in the photovoltaic mode the shunt resistance of the photodiode must be much smaller than the load resistance of the photodiode, i.e. must be fulfilled $R_{SH} \ll R_L$. By choosing $R_L = 1 \text{ M}\Omega$ this condition is certainly fulfilled. The value for the feedback resistance R_F can be arbitrarily chosen to obtain the desired sensitivity. In this application the value of $R_F = 30 \text{ M}\Omega$ was chosen.

According to the simulated results in [Figure 4](#), the maximum output voltage is in the range of $V_{X,Y_{MAX}} \approx 1 \text{ V}$. Therefore, the current that flows through the feedback resistor and thus through the load resistors is smaller than $I_{F_{MAX}} = V_{X,Y_{MAX}}/R_F \approx 33 \text{ nA}$, which is much smaller than the operational amplifier quiescent current of $I_Q = 375 \text{ nA}$. The operational amplifier quiescent current must fulfill the condition $I_Q \ll \mathfrak{R}AE$ to enable the simultaneous work of the photodiode in the photovoltaic mode and proper biasing the operational amplifiers. Since $\mathfrak{R}AE \approx 37 \mu\text{A}$ for the minimum solar irradiance of $E = 1 \text{ mW/cm}^2$ this condition is also fulfilled.

6 Example Implementation

Using an evaluation board for the SLG88103 operational amplifiers and photodiodes the test circuitry was created. The photo of the proto-board realized circuitry, together with the photodiode-based sensor, is shown in [Figure 5](#). The cylinder, i.e. the shadower, is fixed onto the sensor board in order to form the shadow when illuminated by the Sun. The cylinder dimensions can be chosen with regard to the sensor sensitivity and the required measurement range. The sensor that was used in this application note has a shadower of the cylindrical shape with the inner diameter of the cylinder of 38 mm and the height of the cylinder of 35 mm.

Self-Powered Solar Tracking Sensor

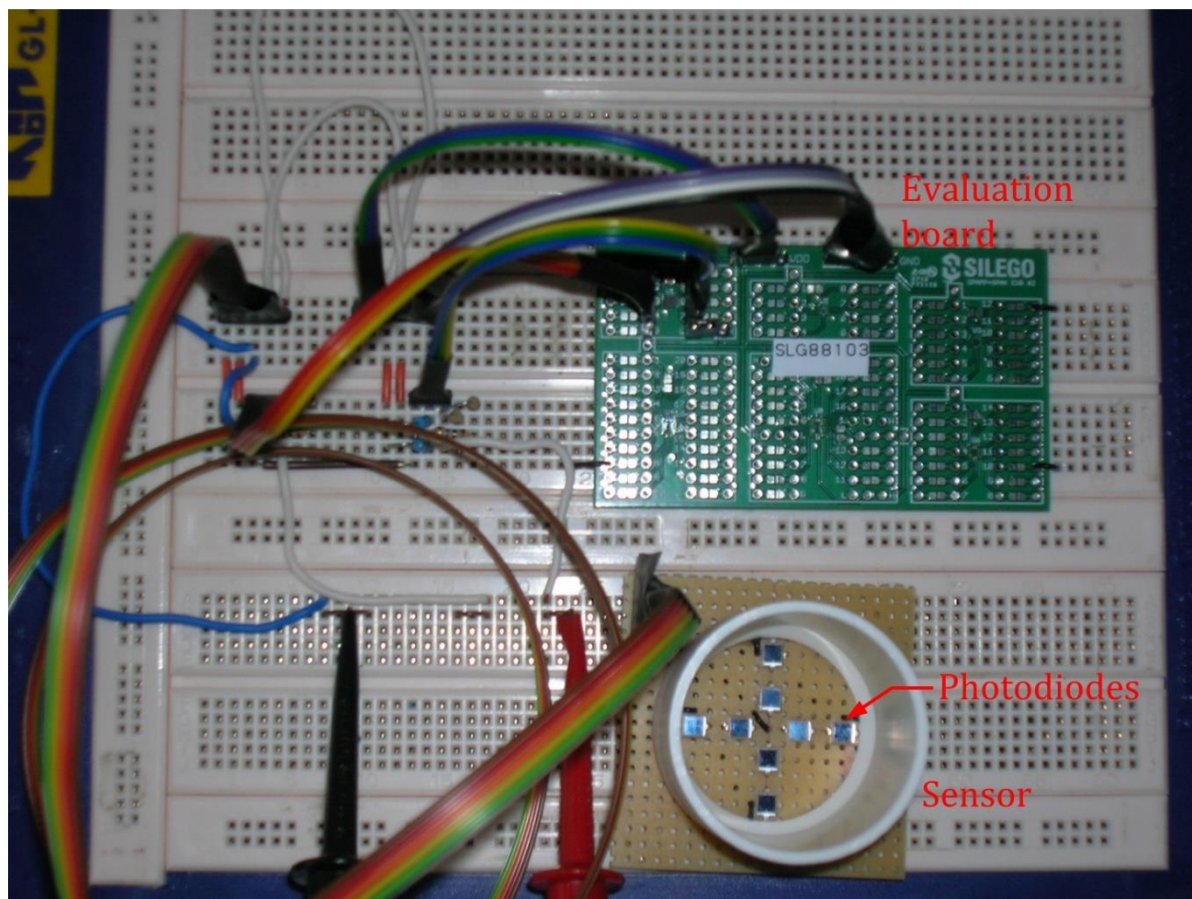

Figure 5: Photo of the Test Board Together with the Sensor

In order to determine the overall sensor circuitry transfer function, the sensor was mounted on a platform, whose tilt angles can be varied. The sensor was directed toward the Sun and by controlling the tilt angles, i.e. the pitch and roll angles of the platform, both voltages V_X and V_Y were adjusted to be as close as possible to zero. Then, by changing the corresponding tilt angles of the platform, the pitch and roll angles of the sensor were changed with respect to the Sun in the range from -5° to $+5^\circ$ while simultaneously measuring the output voltages. The transfer function of the sensor circuitry is presented in [Figure 6](#). Based on the measured data set it was estimated that the sensor sensitivity is approximately $S \approx 56 \text{ mV}/^\circ$.

Self-Powered Solar Tracking Sensor

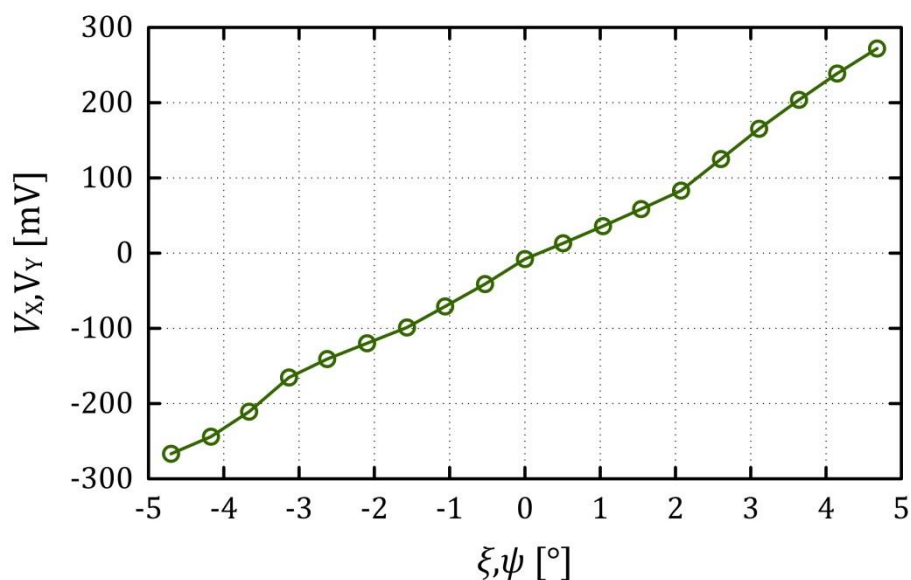

Figure 6: Transfer Function of the Sensor Circuitry

7 Conclusion

Solar tracking sensor has a very important role in many solar power systems (photovoltaic systems) to increase the overall system efficiency. In order to direct the solar panels toward the Sun a control loop, using the signals obtained from the solar tracking sensor, rotates the panels toward the Sun. Therefore, a simple, reliable (without additional power supply), and cost-effective sensor, as presented in this application, will improve the characteristics of the solar power system.

The presented self-powered solar tracking sensor circuitry can be tested with different combinations of photodetectors and shadowing geometries to achieve characteristics that can better fit into the end user requirements.

Self-Powered Solar Tracking Sensor

Revision History

Revision	Date	Description
1.0	16-Aug-2018	Initial Version

Self-Powered Solar Tracking Sensor

Status Definitions

Status	Definition
DRAFT	The content of this document is under review and subject to formal approval, which may result in modifications or additions.
APPROVED or unmarked	The content of this document has been approved for publication.

Disclaimer

Information in this document is believed to be accurate and reliable. However, Dialog Semiconductor does not give any representations or warranties, expressed or implied, as to the accuracy or completeness of such information. Dialog Semiconductor furthermore takes no responsibility whatsoever for the content in this document if provided by any information source outside of Dialog Semiconductor.

Dialog Semiconductor reserves the right to change without notice the information published in this document, including without limitation the specification and the design of the related semiconductor products, software and applications.

Applications, software, and semiconductor products described in this document are for illustrative purposes only. Dialog Semiconductor makes no representation or warranty that such applications, software and semiconductor products will be suitable for the specified use without further testing or modification. Unless otherwise agreed in writing, such testing or modification is the sole responsibility of the customer and Dialog Semiconductor excludes all liability in this respect.

Customer notes that nothing in this document may be construed as a license for customer to use the Dialog Semiconductor products, software and applications referred to in this document. Such license must be separately sought by customer with Dialog Semiconductor.

All use of Dialog Semiconductor products, software and applications referred to in this document are subject to Dialog Semiconductor's [Standard Terms and Conditions of Sale](#), available on the company website (www.dialog-semiconductor.com) unless otherwise stated.

Dialog and the Dialog logo are trademarks of Dialog Semiconductor plc or its subsidiaries. All other product or service names are the property of their respective owners.

© 2018 Dialog Semiconductor. All rights reserved.

Contacting Dialog Semiconductor

United Kingdom (Headquarters)

Dialog Semiconductor (UK) LTD
Phone: +44 1793 757700

Germany

Dialog Semiconductor GmbH
Phone: +49 7021 805-0

The Netherlands

Dialog Semiconductor B.V.
Phone: +31 73 640 8822

Email:

enquiry@diasemi.com

North America

Dialog Semiconductor Inc.
Phone: +1 408 845 8500

Japan

Dialog Semiconductor K. K.
Phone: +81 3 5769 5100

Taiwan

Dialog Semiconductor Taiwan
Phone: +886 281 786 222

Web site:

www.dialog-semiconductor.com

Hong Kong

Dialog Semiconductor Hong Kong
Phone: +852 2607 4271

Korea

Dialog Semiconductor Korea
Phone: +82 2 3469 8200

China (Shenzhen)

Dialog Semiconductor China
Phone: +86 755 2981 3669

China (Shanghai)

Dialog Semiconductor China
Phone: +86 21 5424 9058

IMPORTANT NOTICE AND DISCLAIMER

RENESAS ELECTRONICS CORPORATION AND ITS SUBSIDIARIES (“RENESAS”) PROVIDES TECHNICAL SPECIFICATIONS AND RELIABILITY DATA (INCLUDING DATASHEETS), DESIGN RESOURCES (INCLUDING REFERENCE DESIGNS), APPLICATION OR OTHER DESIGN ADVICE, WEB TOOLS, SAFETY INFORMATION, AND OTHER RESOURCES “AS IS” AND WITH ALL FAULTS, AND DISCLAIMS ALL WARRANTIES, EXPRESS OR IMPLIED, INCLUDING, WITHOUT LIMITATION, ANY IMPLIED WARRANTIES OF MERCHANTABILITY, FITNESS FOR A PARTICULAR PURPOSE, OR NON-INFRINGEMENT OF THIRD PARTY INTELLECTUAL PROPERTY RIGHTS.

These resources are intended for developers skilled in the art designing with Renesas products. You are solely responsible for (1) selecting the appropriate products for your application, (2) designing, validating, and testing your application, and (3) ensuring your application meets applicable standards, and any other safety, security, or other requirements. These resources are subject to change without notice. Renesas grants you permission to use these resources only for development of an application that uses Renesas products. Other reproduction or use of these resources is strictly prohibited. No license is granted to any other Renesas intellectual property or to any third party intellectual property. Renesas disclaims responsibility for, and you will fully indemnify Renesas and its representatives against, any claims, damages, costs, losses, or liabilities arising out of your use of these resources. Renesas' products are provided only subject to Renesas' Terms and Conditions of Sale or other applicable terms agreed to in writing. No use of any Renesas resources expands or otherwise alters any applicable warranties or warranty disclaimers for these products.

(Rev.1.0 Mar 2020)

Corporate Headquarters

TOYOSU FORESIA, 3-2-24 Toyosu,
Koto-ku, Tokyo 135-0061, Japan
www.renesas.com

Contact Information

For further information on a product, technology, the most up-to-date version of a document, or your nearest sales office, please visit:
www.renesas.com/contact/

Trademarks

Renesas and the Renesas logo are trademarks of Renesas Electronics Corporation. All trademarks and registered trademarks are the property of their respective owners.