



Multi-functional remote controls with Dialog's DA14580 Bluetooth® Smart controller

Author(s) **Marios Iliopoulos, Pavlos Bougas**
Revision **Final**
Release Date **April 2015**

Dialog Semiconductor

L. Katsoni & Achilleos 8,
17121, Kallithea, Athens
Greece

Phone: +30 210 93 10 580

Neue Straße 95
73230 Kirchheim/Teck
Germany

Phone: +49 7021 805-0

1 Remote controls past and present

For over a century, television and home entertainment has been our lives. Today, we can't think of using our televisions without a remote control. The first remote control was invented 60 years ago by Eugene Polley. Although the form, the number of buttons, and the interface may have changed since this invention in 1955, the purpose of the TV remote remains the same: to allow people to control devices and appliances wirelessly without getting off the couch.

Going back to 1950s, the first wireless remote was the Flash-Matic, it's design encapsulating the space-age futurism of the decade. Eugene Polley's remote emitted a visible light beam that the user had to aim accurately at one of four sensors on a TV set to change channels, adjust the volume, and turn the TV on or off [1].

In 1956, Robert Adler developed "Zenith Space Command", a mechanical ultrasound remote control for changing channels and adjusting volume. When the user pushed a button on the control, it clicked and struck a bar, hence the term "clicker". Each bar emitted a different ultrasound frequency and circuits in the television detected this sound. A few years later the invention of the transistor made cheaper electronic remotes possible. Early electronic remotes contained a piezoelectric crystal that was fed with an oscillating electric current at a frequency near or above the upper threshold of human hearing. The receiver contained a microphone attached to a circuit tuned to the same frequency. The device had its problems – the receiver could be triggered accidentally by naturally occurring noises, and some people could hear the piercing ultrasonic signals [2].

In 1980, a Canadian company, Viewstar, Inc., was formed by engineer Paul Hrivnak. Viewstar started producing a cable TV converter with an infrared remote control and sold it through Philips. The Viewstar converter was an immediate success, the millionth converter being sold on March 21, 1985, with 1.6 million sold by 1989.

In 1993, Sony proved its innovation skills in electronics, releasing a futuristic touchscreen remote for its SL-HF2100 VCR. The illuminated display of the Sony SL-HF2100 Remote featured 12 modal screens not unlike the displays on today's smartphones.

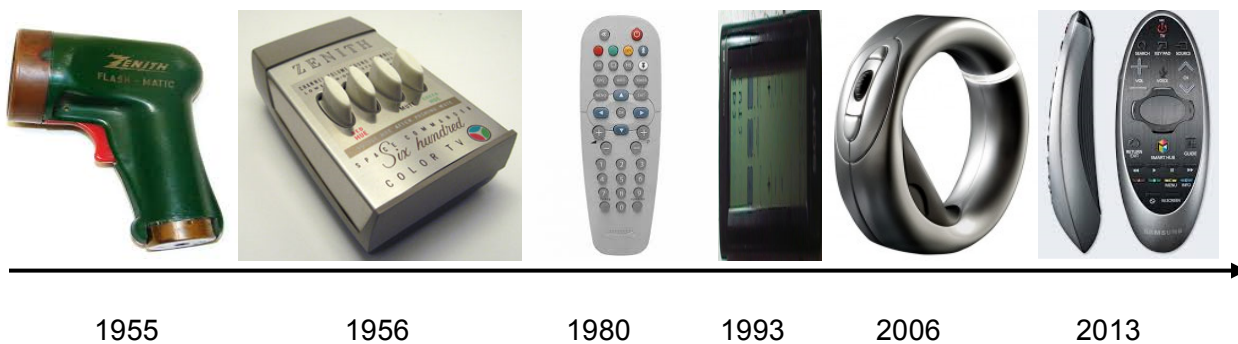

Figure 1: Evolution of remote controls

In 2006, Hillcrest Labs introduced the Loop pointer, a remote control that used Hillcrest's Freespace motion control technology to allow users to control televisions with natural gestures. The Loop had just four buttons and a scroll wheel. Freespace-enabled remote controls use radio waves to communicate with a USB antenna connected to a computer that is also connected to the television, so they do not need to be pointed at the PC, or even have a direct line of sight.

Some television manufacturers now include Bluetooth remotes to control televisions without requiring line of sight, overcoming the limited range of IR-based remotes.

2 Smart TVs and multi-functional remotes

The evolution of remote controls is closely connected with the evolution of TV sets. The new features of TVs had to go hand-to-hand with the features supported by the respective remote controls. The four buttons of the first remote (volume up/down, change channel and turn TV on/off) were replaced by several buttons and numeric keypads in infrared remotes and later by touch screens..

Remotes became more complex and advanced with the introduction of so-called "smart TVs".

Originally called "connected TVs," these were later branded by companies such as Samsung and LG as "smart TVs." The term has come to denote any television that can be connected to the Internet to access streaming media services and that can run entertainment apps, such as on-demand video-rental services, Internet music stations or web browsers.

As smart TVs function in a similar way to PCs, remote controls need to support a greater variety of actions. These may include changing pages, typing web addresses, scrolling pages up-down etc., that are not supported by conventional remotes. Moreover, these functions need to be accessible in a simple, user friendly way. Conventional remotes don't offer that.

One approach is to combine conventional operation on one side of the remote with a QWERTY keyboard on the other. This makes things easier when you want to type text into a web browser or complete online forms. However it is not an elegant solution when you simply want to select the right window and click.

This problem is solved with a combination of QWERTY keyboard and touch pad. Some remote controls implement capacitive touch to emulate a mouse-pad on the remote. Another way to do that is with motion sensing. With the addition of an accelerometer and gyro, 3-D sensor information is transmitted to the TV, making it easy to emulate an air-mouse pointer with the remote control.



Figure 2: QWERTY remotes

Today, it's becoming increasingly popular for remote controls to integrate functionality for voice commands. A microphone is placed inside the remote and voice commands are transmitted to the TV. As smart TVs are connected to the internet, it is then easy to use a voice recognition cloud service and translate long phrases into text commands for web-browsing or perhaps searching a movie application.

The growing functionality of remote control units, which sometimes involves two-way communication with a TV to display status or get other feedback, increases the amount of data that needs to be transmitted and received. Line-of-sight communications is too restrictive so RF technologies like RF4CE, ANT, Bluetooth or Bluetooth Smart are now preferred. Moreover, as a typical user doesn't want to change the batteries every couple of months, the technology of choice needs to provide very low transmission power. Finally, as remote controls are considered low-cost peripherals, the system cost needs to be kept very low.

Taking all of this into account, a remote control that will cover current and future needs for smart TVs should have the following characteristics:

- Be based on an efficient, low cost wireless technology
- Integrate audio capture and motion sensing
- Have very low power consumption for key or voice/motion transmission
- Allow very low cost implementations

3 Multi-functional remote controls platform based on DA14582

Following the introduction of DA14580 Bluetooth Smart controller, which enables the smallest, most power efficient and lowest cost Bluetooth Smart systems, Dialog Semiconductor today offers a development platform that provides all the above remote control functions in a single reference design for developing multi-functional remote controls for smart TVs and Set-Top-Boxes. The development

platform supports the latest addition to Dialog's Bluetooth Smart family of products, the DA14582 Bluetooth Smart SoC. This device integrates an audio codec and is optimized for advanced remote control applications:

- It supports Bluetooth smart technology which is the most power efficient technology, compared to other available RF technologies for remote controls [3]
- It offers the lowest power consumption for receive, transmit and standby operation of any Bluetooth Smart controller
- It integrates an audio codec in the same package
- It is the smallest, most integrated Bluetooth Smart solution, requiring the fewest external components for a complete system implementation

The Dialog semiconductor Voice and Motion remote control reference platform developed around the DA14582 chip integrates the necessary features for a remote control developer to deliver all requirements for smart TV remote controls:

- It provides ultra low power system operation based on the low power consumption of DA14582 and facilitates very low power operation of system components by shutting them down when they are not used.
- It integrates on-board flash for storing firmware and pairing information and allows firmware upgrades through Dialog development tools or Over-The-Air using smartphone applications.
- It supports a customisable 27 key, 6 x 5 matrix.
- It supports advanced, low power key-processing by detecting simultaneous key-presses, allowing programmable key de-bouncing and de-ghosting.
- It integrates an audio subsystem that samples 16-bit, 16 kHz audio, encodes it into IMA-ADPCM packets and transmits them over the air through standard HID protocol. The system provides audio buffering exceeding 500 ms, allowing smooth audio operation even in RF-dense environments.
- It supports an accelerometer and gyro (Bosch BMI055) to implement a pointing device similar to a mouse using the information coming from gyro/accelerometer sensor and Hillcrest host libraries.
- It provides a host demo application for Windows and Android platforms that can be used as starting-point for development of customer applications.

The reference application is based on the HID over GATT Profile 0. It is an adaptation of the USB HID specification for operation over a Bluetooth low energy wireless link. The HID over GATT profile requires the Generic Attribute Profile (GATT), the Battery Service and the Device Information Service. The remote application implements the HID Device role. The GATT role is Server and the GAP role is Peripheral.

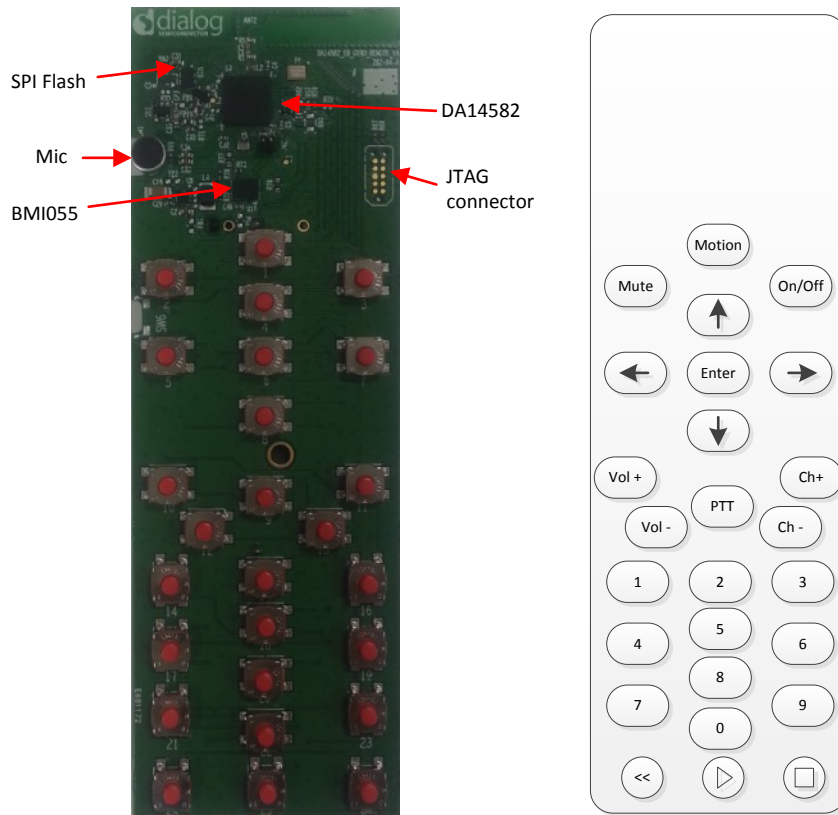

Figure 3: RCU voice and motion development platform

The hardware architecture of the Voice and Motion remote control reference platform includes the following hardware blocks:

Block	Main part	Interface	Comments
Flash	W25X20CL	SPI	External flash memory with SPI interface used to store the firmware and the bonding data
Gyro/Accelerometer	BMI055	I2C, Interrupt line	Accelerometer and Gyro used for the motion control
Key Matrix	-	11 GPIOs	Typical 6x5 key matrix configuration
Debug Connector		Jtag, Uart	A PCB based connector for JTAG control and UART connection

The audio codec that is integrated into DA14582 is a powerful analog block that allows wideband sampling and buffering, and is connected to the DA14580 through an SPI interface. The audio codec is used as an input device only. However, its operation could be extended also to provide an audio output..

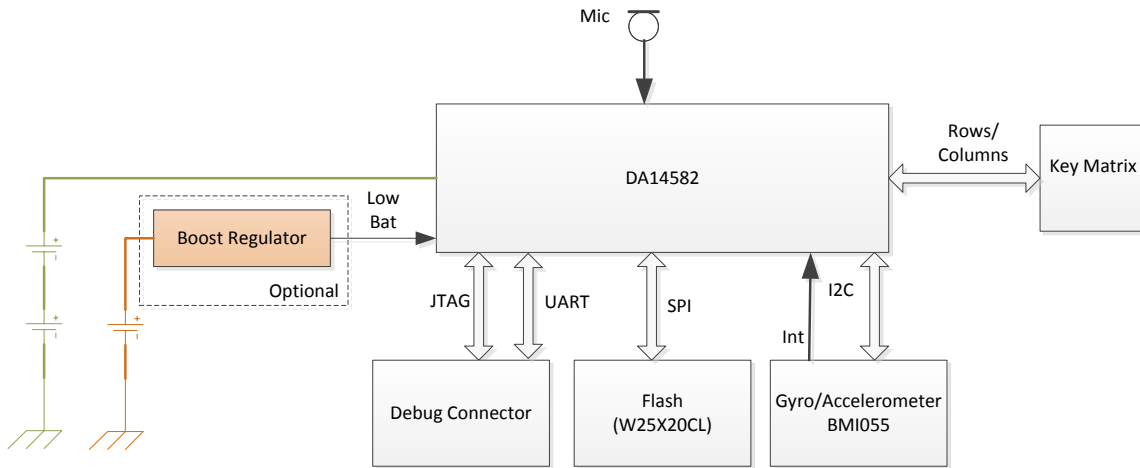

Figure 4: HW architecture of the Bluetooth Smart Voice and Motion Remote Control

Windows 8.1 and an Android demo host applications and their source code are included in the reference design package, both to showcase a demo application and as a starting point for customer development.

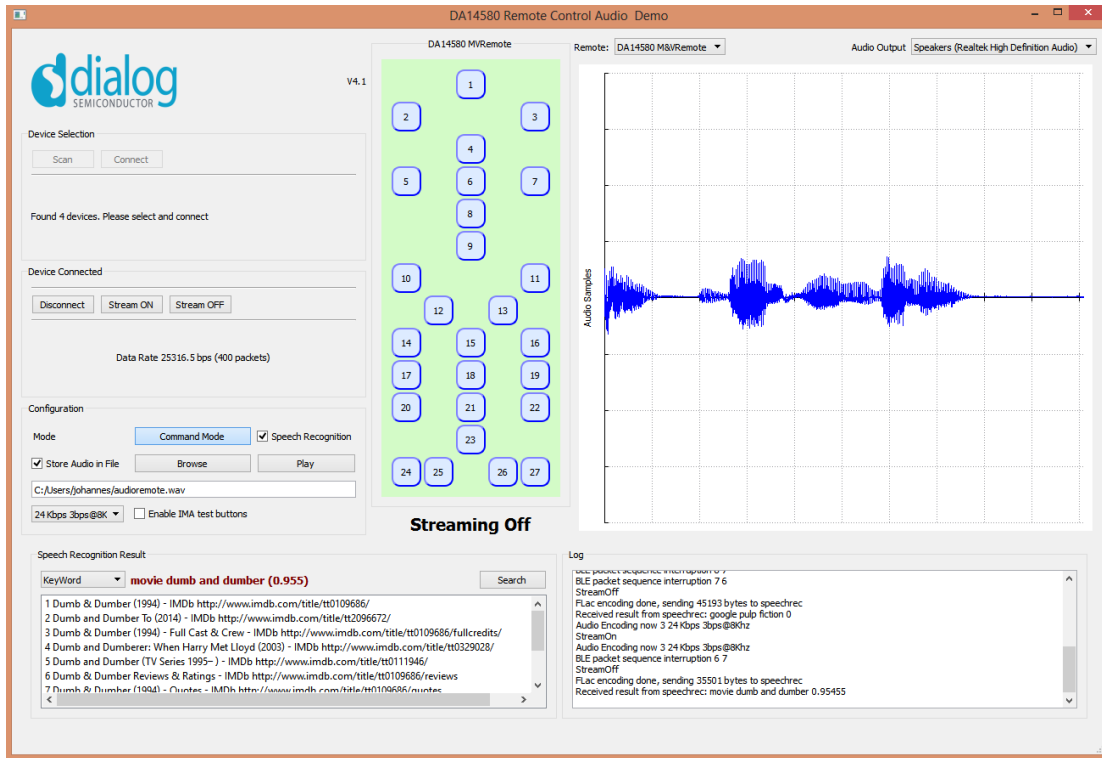

Figure 5: Host application

The application provides the following functions to the user:

- **Logging:** provides a textbox that displays messages, warnings and debug information.
- **Audio Capture:** The user can select to store the audio data captured in a file.
- **Device Selection:** This area contains a listbox of available HID drivers and the user can select the HID driver of the RCU to be communicated with. After communication is established the application is in Connected Mode. In this area three buttons appear to start and stop the Audio Stream without the use of the SW9 (PTT) key from the host, or to disconnect the application from the HID driver.
- **Remote Key Press Visualization:** This area contains a sketch of the remote control layout. It is used to visually show the press and release of the remote control buttons. At the bottom of this area a large label shows the status of the remote when connected.
- **Selectable Audio Output:** The audio output list box shows all the audio devices available in the host. The user selects the audio device to be used for audio playback.
- **Real-Time Audio Plots:** The application supports real time plotting of the audio data received from the RCU.
- **Search Application Selection:** The application supports invoking a configurable application that uses the translated voice commands for “string searching”.

The control/data path flow for audio application is as follows:

1. Codec is powered up when the voice command key is pressed.
2. The DA14582 configures the integrated codec using the SPI.
3. Codec is configured to sample data with 16 bit/16kHz rate and store them in its internal RAM in a ring buffer.
4. DA14582 encodes the audio samples in IMA-ADPCM and stores them in a second fifo.
5. Samples are streamed over BLE using the fastest possible rate to the remote device. Since HID reports are used, there is no need to develop an extra profile on the other side. Streaming over custom profile is also possible.
6. On the host side, data are read in Java application and decoded. They can be saved in a file if this is required.
7. For voice commands data are re-encoded in Flac format to be pushed into the Google engine via a web client to get back the final result.

The data path for motion application is as follows:

1. User activates the motion via a special key press. Alternatively, the accelerometer could be used to automatically activate the remote through motion sensing.
2. DA14582 powers-up and configures the sensor.

3. Sampling of the data is synchronized with the connection event to keep the latency at the minimum possible level.
4. Data are sent over HID.
5. Data are probed from within the Bluedroid stack. Solution is native to minimise the latency.
6. Data are pushed into a Native client and forwarded to the Hillcrest Library in order to show the mouse pointer on the screen.

3.1 Power consumption

The DA14582 voice+motion RCU platform demonstrates unprecedented power consumption figures:

- extended sleep of <math><8 \mu\text{A}</math> (all system memory maintained).
- during Tx of voice commands 10 mA at 3 V.
- during motion operation 8 mA.

This means that for a typical remote control application with audio and motion the lifetime when 2 alkaline cell batteries are used is:

- More than 10 years of standby.
- More than 1year of active operation if 200 key presses are performed per day and half an hour of voice commands or 40' of motion operation are performed per day.

4 Future enhancements of remote control platform

Future remotes will integrate even more functionality. Some features that will be integrated in DA1458x SmartBond SoCs, including:

- Automated selection of encoder/decoder to adapt to RF-intense environments
- 'Findme' functionality, the remote control platform integrating a buzzer so that it can be traced using a "locate" button on a smartphone or TV .
- Motion activated remote control functionality.
- Bi-directional audio, allowing playback functions in the remote.
- More advanced host libraries for smoother integration of audio in smartTV / Set-Top-Box devices.

Dialog provides a roadmap for the upcoming DA1468x family. In addition to 580 existing features new SoCs will provide an integrated PDM interface for digital microphones and more headroom in the application processor for including functionality such as:

- Always-on voice trigger to remove the need for pressing a button to activate voice commands, as they will be activated by a pass-phrase.
- Beam tracking/de-reverberation to eliminate the need to hold the remote for performing voice commands, allowing the device to be located in a remote location.

5 Summary

As presented in this paper, Dialog's DA14582 SoC already offers a powerful reference platform that combines all the required characteristics for today's smart TV remote controls. Moreover, through Dialog's software and hardware roadmap, remote control developers have a solution that is future-proof, minimizing development risks.

6 References

- [1] A Tribute to the TV Remote Control: Past, Present, and Future, Liviu Oprescu, PCWorld, http://www.techhive.com/article/257078/a_tribute_to_the_tv_remote_control_past_present_and_future.html
- [2] Wikipedia, remote control, http://en.wikipedia.org/wiki/Remote_control
- [3] "Power Consumption Analysis of Bluetooth Low Energy, ZigBee and ANT Sensor Nodes in a Cyclic Sleep Scenario", Artem Dementyev, Steve Hodges, Stuart Taylor and Joshua Smith
- [4] HID over GATT Profile Specification, HOGP_SPEC_V10.pdf, Bluetooth SIG