USB Power Delivery Changes the Game

Abstract

Connections between equipment for data transfer and power are being revolutionized by the adoption of ‘USB Power Delivery’, a version of USB that allows up to 240W to be passed in either direction. This white paper traces the history of the standard and its capabilities up to the present day with USB Type-C® cables and connectors enabling ‘Super-speed’ communication while providing bi-directional power transfer for peripheral operation and battery charging.

Practical advantages of USB Power Delivery are described along with the wider benefits of reduction in complexity and number of interconnections and their environmental impact. Integrated circuit solutions for the design of interfaces to control power flow are introduced.

Contents

Abstract	1
USB Power Delivery origins	2
Capabilities of USB Power Delivery Introduced	3
USB Type-C® Connectors Enable More Functionality	4
Controllers Implement the Features of USB PD	6
USB PD Needs Device Controllers	6
Conclusion	8
References	8
Revision History	9

USB Power Delivery origins

The Universal Serial Bus concept was born in 1994 with its origins in a forum of industry leaders - Intel, Microsoft, Compaq, IBM and NEC. The idea was to replace the proliferation of serial and parallel interfaces in computer systems that needed expansion cards and custom drivers with a Universal Serial Interface, USB, that was faster by far and was 'plug and play'. Initially the emphasis was on improved speed and interoperability but a couple of extra wires were added in with +5V power and return from the host. Only 100mA was available according to the original USB 1.0 specification but that was useful for a mouse or other very low power peripherals.

As data transfer speed requirements increased, the 12 megabits/second optimistically-termed 'full speed', of USB 1.0 became inadequate and USB 2.0 was introduced in 2000 with a leap to 480 megabits/second. A principle of USB design is backwards compatibility so USB 2.0 devices could operate at the lower rates down to 12 or even 1.5 megabits/second. USB 2.0 also upgraded the 5V power source capability to 500mA/2.5W which users soon found could be useful for charging batteries in portable devices such as cell phones. As this became a common use for a USB port, often with no data exchange at all, the founding organization 'USB Implementers Forum' (USB-IF)^[1] introduced USB 3.0 which, amongst other things increased power to 900mA/4.5W and introduced a mode 'CDP' (Charging Downstream Port). A battery charging specification (USB BC) was generated in 2007 which allowed yet higher current to 1.5A, or 7.5W at 5V. BC 1.2 in 2010 introduced a more robust specification for charging operation. International standardization of USB performance for data and power has now been formalized, IEC 62680 series^[2].

A feature of USB so far was that power could only be sourced from the host although data was bi-directional. The connector is 'hot' with 5V present continuously, meaning that two hosts in theory could interconnect and exchange data but would both try to apply power which could damage one or the other. Active devices that could source power at different current levels need to 'enumerate' with the peripheral to communicate what power is available and required, with this done over the data lines, interrupting their operation. Dedicated charging ports did not need enumeration, however. These disadvantages, along with the 7.5W power limit were problematic to further development of power sourcing over USB.

A parallel topic was the increasing complexity and compatibility problems seen interconnecting and powering peripherals that might be used with a PC or laptop. More devices started to use adapters or 'wall-warts' for AC power conversion to perhaps 19V for a laptop or 12V for a printer or external hard drive. A desk top might look like **Figure 1** with multiple tangled and incompatible power and data cables.

USB Type-C® and USB-C® are trademarks of USB Implementers Forum. All product names, trademarks and registered trademarks are property of their respective owners.

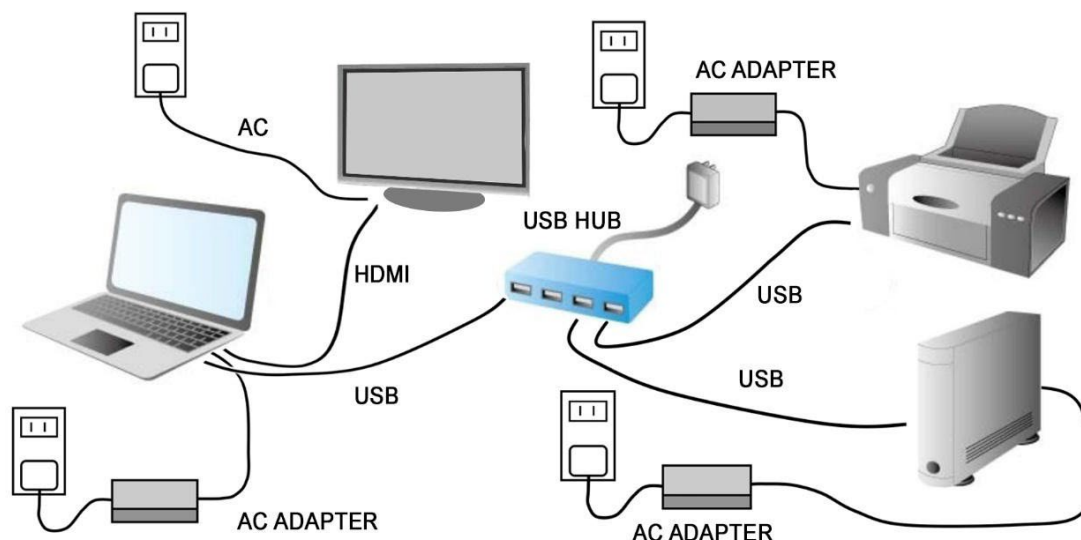

Figure 1. Interconnections before USB PD

When travelling, several heavy adapters and chargers might be needed along with foreign mains socket converters. The problem of E-waste also came to the fore with average households accumulating boxes of cables and obsolete adapters that didn't match the latest gadgets bought. The variety of USB connectors that had emerged also didn't help with 'standard', 'mini', 'micro' form factors in type A, B and AB. USB 3.0 also introduced a 'superspeed' transfer mode which started at 5 Gigabits/second and increased to 10 Gigabits/second with revision 3.1. Furthermore, the latest standard as of 2026, USB4 Version 2.0, will support speeds up to 80Gbps.

Capabilities of USB Power Delivery Introduced

To address the power limit situation, USB 'Power Delivery' specification USB PD 1.0 was conceived and released in 2012 by the USB Implementers Forum, USB-IF. This allowed in an output voltage range of 5V to 20V and a maximum negotiated current of 5A, enabling a total power supply of up to 100W. As of 2026, the latest standard, USB PD3.2, will further enable power supply and reception up to a maximum of 240W(48V/5A). This opened up the tantalizing possibility of charging laptops directly from a USB port or powering peripherals like monitors over USB cables, eliminating the separate mains connection. The specification includes detail of the enumeration between devices to ensure that over-voltage is not applied and current is limited to what is required only. Initially the source outputs 5V, deemed as safe for all legacy devices and limits power to 10W. Thereafter, negotiation takes place to set Output Source Power. See **Table 1**.

Table 1. USB PD Output Source Power

Standard Power Range	Current at: (A)		Extended Power Range	Current at: (A)
	3 (max)	5 (max)		
Voltage			Voltage	5 (max)
+5V	15W	25W	28V	140W
+9V	27W	45W	36V	180W
+15V	45W	75W	48V	240W
+20V	60W	100W		

USB Type-C® Connectors Enable More Functionality

The solution to extracting the full potential of the USB PD specification is the 'USB Type-C®' connector (**Figure 2**). USB Type-C® and USB-C® are trademarks of USB Implementers Forum. With 24 connections in a 'flippable' format, the connector is smaller than types A and B with a plug height of just 2.4mm, ideal for slim-line products. As USB Type-C® connectors can handle 'alternate modes' such as DisplayPort™ over USB-C®, fewer types of connectors are needed on laptops for example.

Now separate power adapters are not necessarily needed with power provided from perhaps the laptop and distributed via the USB Type-C® cables to the monitor and other peripherals. The video signal for the monitor could also use the DisplayPort™ 'alternate mode' connections in the cable. A desktop might now look like Figure 3 with just one connection to AC mains and otherwise all cables identical types.



Figure 2. USB Type-C® connector

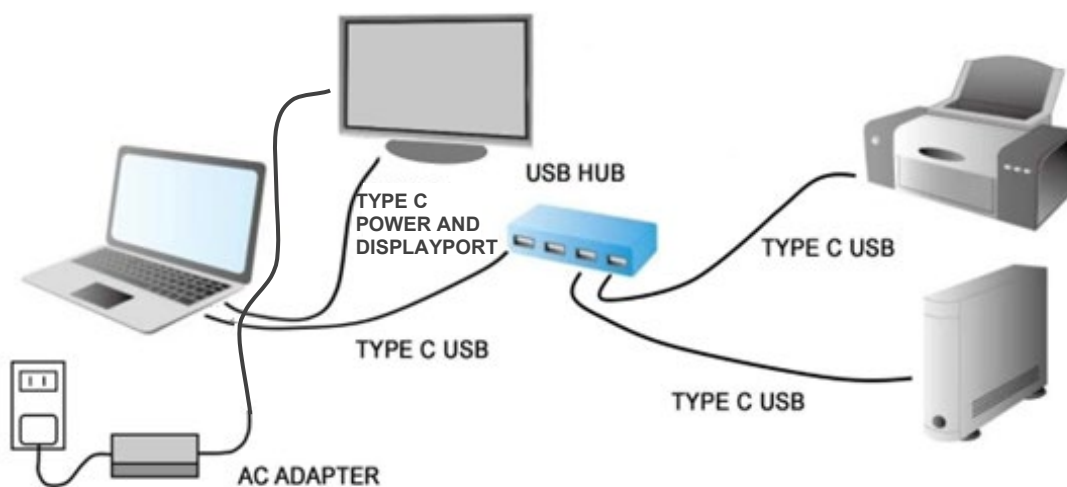

Figure 3. USB Type-C® connections avoid multiple cable types and power adapters

The connector is now 'cold', in that devices interconnected now do not impose any voltage until source and sink have been identified. This facilitates bi-directional power flow which can seamlessly change direction, identified as Fast Role Swap (FRS) – a power bank for example, can have a single USB Type-C® connection to a laptop which automatically switches from charge to discharge. Furthermore, fixed voltage (5V, 9V, 15V, 20V) or programmable value (Programmable Power Supply) function (PPS) and AVS (Adjustable Voltage Supply) are available for power supply connections, enabling fine-grained control of charging applications to achieve maximum efficiency. Lithium-Ion batteries for example, are best charged initially at constant current with slowly increasing voltage, followed by constant voltage. With the fixed voltage of non-USB PD applications, the charge would need to be controlled at the battery with a dissipating regulator. With PPS, the source switched-mode power supply can be programmed to do the same with little or no change in efficiency.

Standard IEC 63002^[3] defines the protocols for monitoring and controlling an External Power Supply (EPS).

Controllers Implement the Features of USB PD

With flexibility comes the requirement to monitor and control the power flow and data connections so there must be an active controller in devices at each end of a USB PD system. Let's look at a typical scenario of an AC adapter connected to a device by a compliant USB Type-C® cable, **Figure 6**.

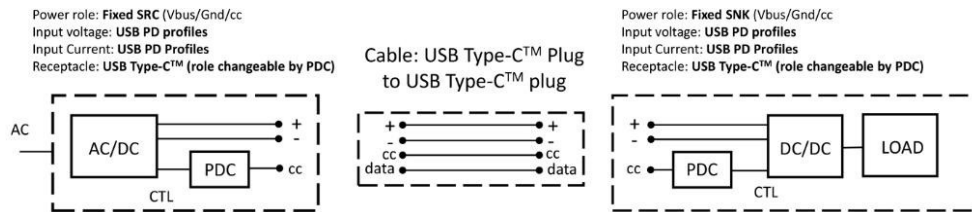

Figure 6. Portable device and AC adapter USB PD application

After the connection is made, 5V is applied to VBUS, marked '+', and by pull-up or down resistors on the CC lines, the adapter on the left is identified as a source and the device on the right as a sink. Communication now starts, and the E-marker in the cable is interrogated to identify the system voltage and cable's current-carrying capacity (3 A or 5 A). Negotiation then follows, with the source stating its power capability and the sink, its requested voltage and current. On agreement of compatibility, the source voltage is raised to the appropriate level. Voltage, current and temperature are monitored at both source and sink, with source power reduced if a problem is detected. Another scenario is typical of a cell phone being charged from an AC/DC adapter through USB PD, **Figure 7**. Charger on the left, cell phone on the right.

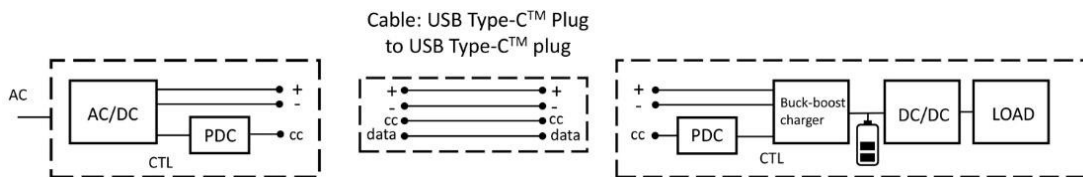

Figure 7. Typical USB PD application of device and charger with USB Type-C® cable

When power flow needs to be bi-directional, a similar 'handshaking' occurs with each device initially 'toggling' between source and sink states until direction of required current is established.

USB PD Needs Device Controllers

Given the complexity of monitoring and control needed, integrated controller solutions have been developed which include the Fast Role Swap and programmable Power Supply features. Devices can include the fault condition monitoring of over-voltage, current and temperature. Having this degree of intelligence in the controller enables compliance with Energy Star® and EuP specifications for low power PC peripheral systems by fine adjustment of dissipation in connected devices through monitoring and setting of bus voltages. Parts can be self-contained with an on-chip oscillator and as small as the R9A02G011^[4] device from [Renesas](#) for example, at 3.6 x 3.1mm in a BGA package.

For the source power requirements, AC-DC or DC-DC converters are needed that can be monitored and controlled according to the USB PD specification. Integrated solutions are again available. For example, the AC-DC adapter in Figures 6 and 7 may be based on a flyback circuit which has Pulse Width Modulation (PWM) control to set the fixed output voltage or variable for PPS applications.

When used with a USB PD controller such as the R9A02G011, form an integrated solution using minimal board area. Parts in the Renesas RAA489800 are also available for the buck-boost regulator function^[5] using a versatile structure of external switching MOSFETs. Parts such as the Renesas RAA489118^[6] can perform battery charging and battery power sourcing as well as buck-boost DC-to-DC power conversion.

USB Power Delivery Changes the Game

There are applications where power conversion needs to be bi-directional. A good example is a 'power bank' connected by USB Type-C® cables to a portable device, **Figure 8**.

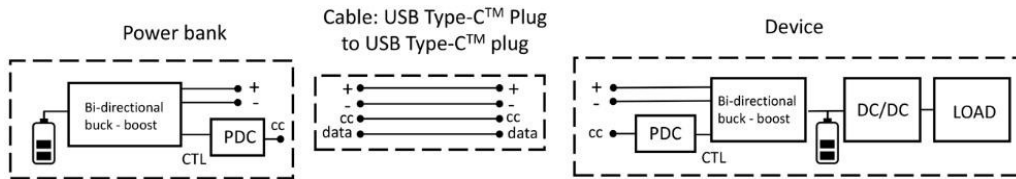

Figure 8. Power bank USB PD application

When the power bank is charging, a voltage within the USB PD range of 5V – 48V is supplied from the device with the final lithium-ion battery cell voltage derived from a step-down 'buck' converter in the power bank. When the power bank is required to provide power, a 'boost' converter supplies a higher voltage back to the original source within the USB PD range. Fortunately, there is a buck-boost converter topology that can perform both functions in one power stage **Figure 9**. Furthermore, with the expansion of the USB PD range to 48V, we are developing a more efficient 3-level buck boost converter in addition to the 2-level buck boost converter shown in **Figure 9**.

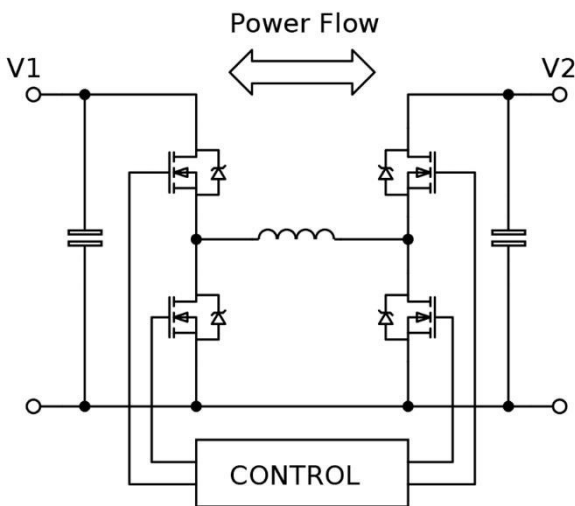

Figure 9. 2 level Buck-Boost converter configuration

By setting combinations of the MOSFETS permanently on or off while switching the others under PWM control, the functions of boost or buck can be achieved in either direction.

The boost conversion ensures that the voltage delivered back to the portable device remains in the USB PD range even as the battery discharges to a low value. A PWM controller is needed for the buck-boost converter, with parts available from Renesas which integrate with their USB PD controllers and provide seamless role reversal from source to sink, buck to boost, with all the necessary fault monitoring included.

Reference design kits are invaluable for developing USB PD solutions, customizing performance to the requirements of the application through firmware. Versions available from Renesas currently are: a generic power sink, a multi-port USB PD Buck-boost DC/DC module and a one-port power bank (battery pack). In addition, there is an evaluation board that enables the implementation of a USB Type-C® battery system. With the integrated facility to re-write flash memory in the Renesas controllers, debugging is easy and updates to a completed design are easily achieved through the USB connection.

Components in a USB PD system can qualify for accreditation in a USB IF compliance program, which provides a guarantee of performance to the USB specifications. Products that comply are added to the Integrators List and can be licensed to show the USB-IF logo. The website www.usb.org features a free-to-view document library, developer information and details of their compliance program. A product search is provided to identify products that meet the USB-IF compliance requirements. All Renesas USB PD products are compliant, enabling end products to be the same and show the compliance logo.

Conclusion

USB PD is a revolution in the powering of devices that applies from cell phones through to power-hungry laptops and monitors. The technology promises a reduction in cabling and the number of power sources needed with consequent savings in energy, cost and waste in the environment. Protection against hazards comes with the package along with many user convenience advantages. Implementing USB PD solutions has never been easier with integrated suites of controllers from companies such as Renesas. Comprehensive design guidelines and application information is available on their website www.renesas.com.

References

- [1] USB Implementers Forum www.usb.org
- [2] IEC 62680 series Universal serial bus interfaces for data and power
- [3] IEC 63002: Identification and communication interoperability method for external power supplies used with portable computing devices
- [4] Renesas R9A02G011 <https://www.renesas.com/eu/en/products/R9A02G011>
- [5] Renesas RAA489800 <https://www.renesas.com/en/products/RAA489800>
- [6] Renesas RAA489118 <https://www.renesas.com/en/products/RAA489118>

Revision History

Revision	Date	Description
2.00	May 19, 2026	USB spec related information and product information updates
1.00	Jan, 2019	Initial release.

IMPORTANT NOTICE AND DISCLAIMER

RENESAS ELECTRONICS CORPORATION AND ITS SUBSIDIARIES (“RENESAS”) PROVIDES TECHNICAL SPECIFICATIONS AND RELIABILITY DATA (INCLUDING DATASHEETS), DESIGN RESOURCES (INCLUDING REFERENCE DESIGNS), APPLICATION OR OTHER DESIGN ADVICE, WEB TOOLS, SAFETY INFORMATION, AND OTHER RESOURCES “AS IS” AND WITH ALL FAULTS, AND DISCLAIMS ALL WARRANTIES, EXPRESS OR IMPLIED, INCLUDING, WITHOUT LIMITATION, ANY IMPLIED WARRANTIES OF MERCHANTABILITY, FITNESS FOR A PARTICULAR PURPOSE, OR NON-INFRINGEMENT OF THIRD-PARTY INTELLECTUAL PROPERTY RIGHTS.

These resources are intended for developers who are designing with Renesas products. You are solely responsible for (1) selecting the appropriate products for your application, (2) designing, validating, and testing your application, and (3) ensuring your application meets applicable standards, and any other safety, security, or other requirements. These resources are subject to change without notice. Renesas grants you permission to use these resources only to develop an application that uses Renesas products. Other reproduction or use of these resources is strictly prohibited. No license is granted to any other Renesas intellectual property or to any third-party intellectual property. Renesas disclaims responsibility for, and you will fully indemnify Renesas and its representatives against, any claims, damages, costs, losses, or liabilities arising from your use of these resources. Renesas' products are provided only subject to Renesas' Terms and Conditions of Sale or other applicable terms agreed to in writing. No use of any Renesas resources expands or otherwise alters any applicable warranties or warranty disclaimers for these products.

(Disclaimer Rev.1.01)

Corporate Headquarters

TOYOSU FORESIA, 3-2-24 Toyosu,
Koto-ku, Tokyo 135-0061, Japan
www.renesas.com

Trademarks

Renesas and the Renesas logo are trademarks of Renesas Electronics Corporation. All trademarks and registered trademarks are the property of their respective owners.

Contact Information

For further information on a product, technology, the most up-to-date version of a document, or your nearest sales office, please visit www.renesas.com/contact-us/.