

Description

The HXT14400 is a quad-channel, low power, Linear PAM4 VCSEL driver for SR optical applications that supports signaling rates up to 28Gbaud or 56Gbps PAM4. In conjunction with an individual DFB laser diode, the device handles the complete digital-to-optical conversion, including CML input with equalization, laser driver, drive control and supervision.

The HXT14400 also integrates a number of functions required for Automatic Power Control (APC), as well as internal and module temperature measurements and reporting. Using the included RSSI input, the module receive optical power can also be measured and reported.

Designed for direct DC-coupled die in TOSA applications with a small number of additional components for cost-effective and compact assemblies. Available in die form.

Typical Applications

- 200G QSFP56 Ethernet modules for datacenter application
- 400G CFP8 Ethernet SR16
- Fiber channel modules
- Infiniband EDR optical modules

Ordering Information

Part	Temperature Range	Dimensions
HXT14400-DNU ¹ HXT14400-TNU ²	-5°C to +95°C	Nominal Die Size: 1650 x 2370 μm
HXT14400-EVB	Room Temp	Evaluation Board

Notes: Product Shipping Carrier Type: ¹ – Waffle Pack; ² – Blue Tape

For price, delivery schedules, and to place orders, please contact IDT: www.IDT.com/go/sales

Features

- 230mW per channel power dissipation typical
- Supports up to: $I_{MOD} = 12mA_{PP}$ and $I_{BIAS} = 12mA$ with $V_{CC} = 3.3V$
- Integrated 12-bit ADC with 6 channel analog multiplexor front-end
- Programmable 8-bit Laser Modulation and Bias current control
- Integrated Bias Monitor, Transmit and Receive Power Monitor capability
- Automatic Power Control (APC)
- Programmable input LOS and squelch function with disable, transmit disable, and transmit fault indication
- Programmable input CTLE equalization
- Integrated temperature sensor and input for external module temperature sensor
- Interrupts with user selectable mask control
- Input polarity inversion
- Laser disable for I_{MOD} and I_{BIAS}
- Integrated OTP for calibration
- 2-wire interface control

Device Diagram

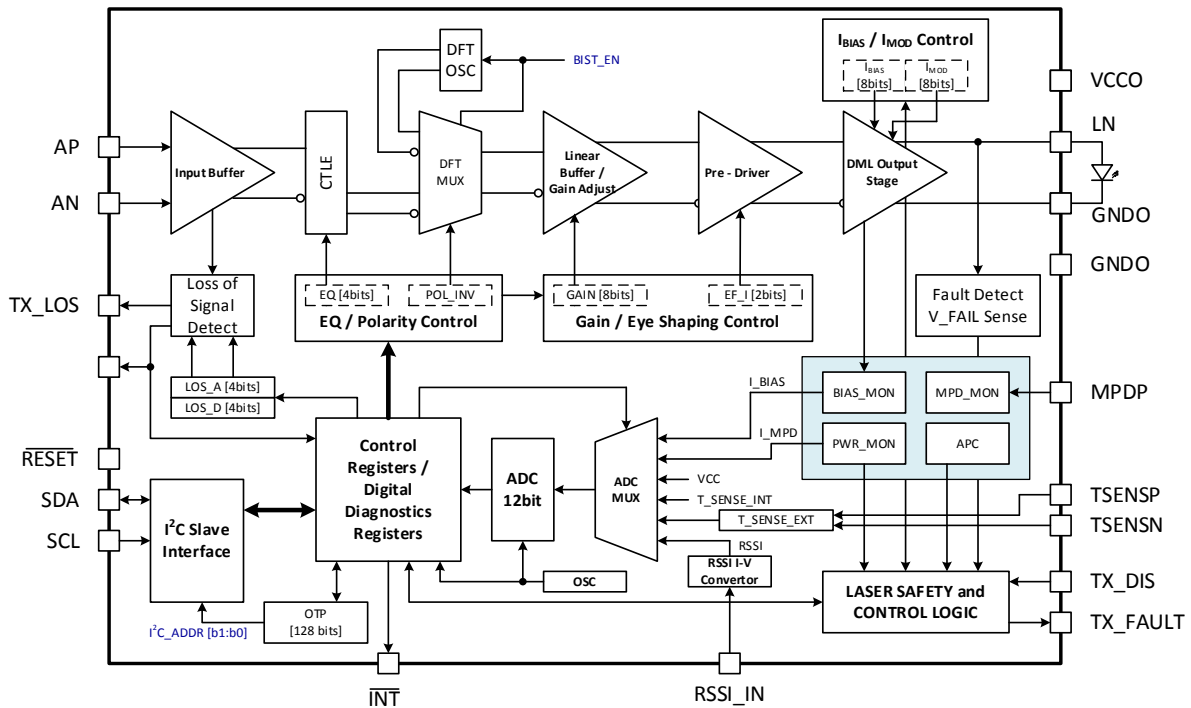

Figure 1: Functional Block Diagram of a Single Channel

IMPORTANT NOTICE AND DISCLAIMER

RENESAS ELECTRONICS CORPORATION AND ITS SUBSIDIARIES (“RENESAS”) PROVIDES TECHNICAL SPECIFICATIONS AND RELIABILITY DATA (INCLUDING DATASHEETS), DESIGN RESOURCES (INCLUDING REFERENCE DESIGNS), APPLICATION OR OTHER DESIGN ADVICE, WEB TOOLS, SAFETY INFORMATION, AND OTHER RESOURCES “AS IS” AND WITH ALL FAULTS, AND DISCLAIMS ALL WARRANTIES, EXPRESS OR IMPLIED, INCLUDING, WITHOUT LIMITATION, ANY IMPLIED WARRANTIES OF MERCHANTABILITY, FITNESS FOR A PARTICULAR PURPOSE, OR NON-INFRINGEMENT OF THIRD-PARTY INTELLECTUAL PROPERTY RIGHTS.

These resources are intended for developers who are designing with Renesas products. You are solely responsible for (1) selecting the appropriate products for your application, (2) designing, validating, and testing your application, and (3) ensuring your application meets applicable standards, and any other safety, security, or other requirements. These resources are subject to change without notice. Renesas grants you permission to use these resources only to develop an application that uses Renesas products. Other reproduction or use of these resources is strictly prohibited. No license is granted to any other Renesas intellectual property or to any third-party intellectual property. Renesas disclaims responsibility for, and you will fully indemnify Renesas and its representatives against, any claims, damages, costs, losses, or liabilities arising from your use of these resources. Renesas' products are provided only subject to Renesas' Terms and Conditions of Sale or other applicable terms agreed to in writing. No use of any Renesas resources expands or otherwise alters any applicable warranties or warranty disclaimers for these products.

(Disclaimer Rev.1.01)

Corporate Headquarters

TOYOSU FORESIA, 3-2-24 Toyosu,
Koto-ku, Tokyo 135-0061, Japan
www.renesas.com

Trademarks

Renesas and the Renesas logo are trademarks of Renesas Electronics Corporation. All trademarks and registered trademarks are the property of their respective owners.

Contact Information

For further information on a product, technology, the most up-to-date version of a document, or your nearest sales office, please visit www.renesas.com/contact-us/.