

LED Notes:  
 RX-Side  
 LED0 = (Yellow) LINK+ACTIVITY  
 LED2 = 100BT (Green)  
 GPIO0 should be configured at LED0  
 GPIO7 should be configured as LED2  
 LEDMODE register should be programmed to 0x0

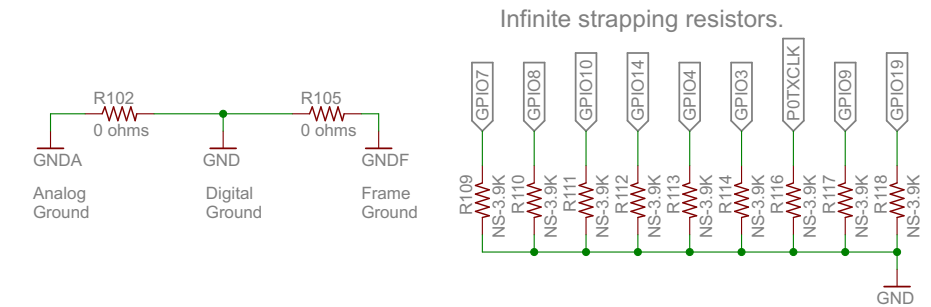

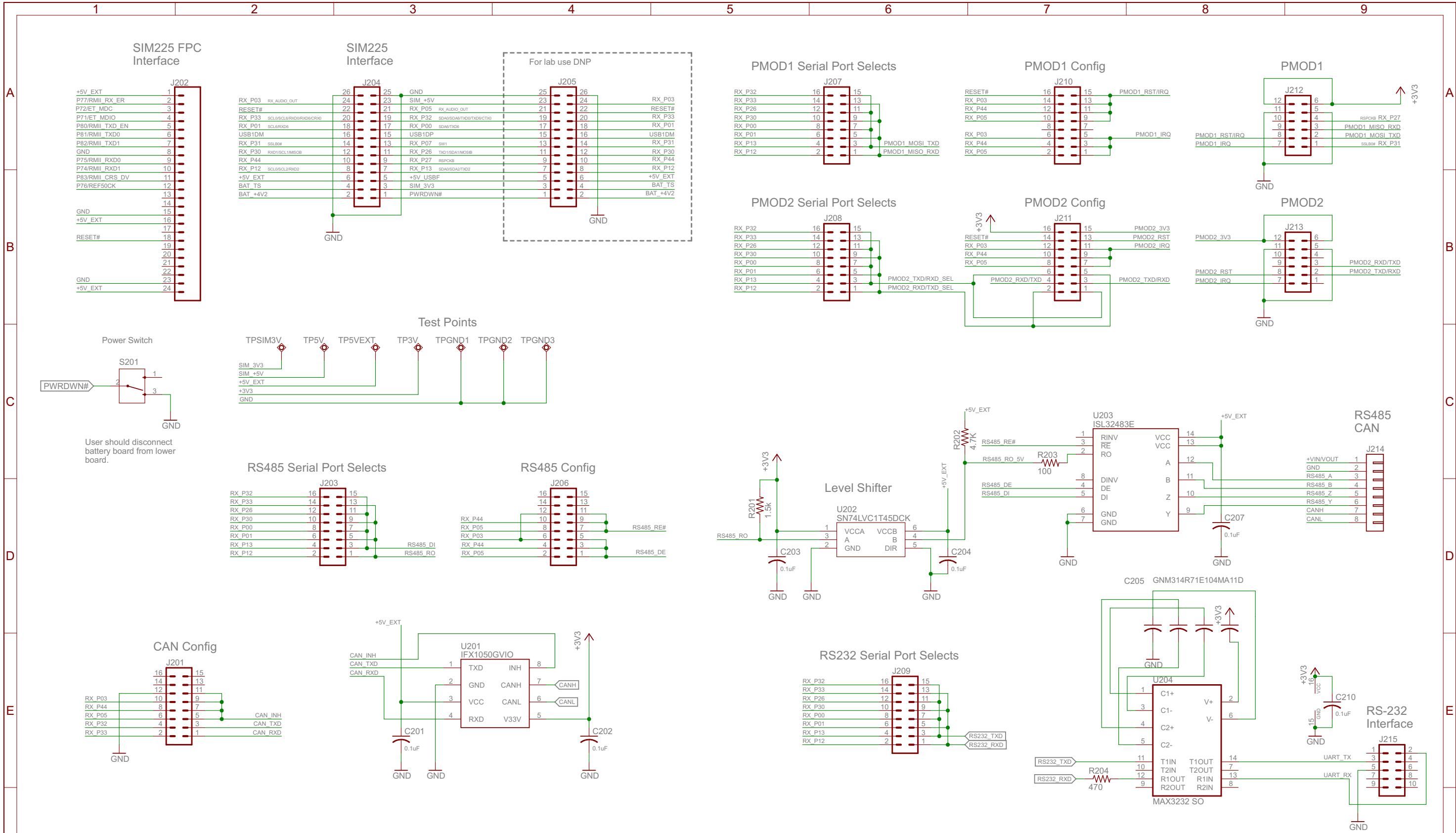

Unused R-pack Resistors



### Serious Communication Module

SIM, RS485, CAN, RS232 & PMOD connections

TITLE: YDBENETPMOD\_v03

REV: v03

**Serious** (c) Serious Integrated, Inc

Date: 8/15/2013 12:03:07 PM

Sheet: 2/2