

HW10120_FC3_RC32308A_QFN48_RevD



Renesas
603 March RD
Kanata, ON K2K 2M5

Title: HW10120_FC3_RC32308A_QFN48_RevD

Size B	HW Number: HW10120	Engineer: Kapilan Ramachandran	Rev. D
	Date: 07/23/2025	Sheet: 1 of 5	

REV.	DESCRIPTION	DATE	ENGINEER
A	INITIAL RELEASE	07/05/22	Dung Nguyen
B	-----	10/13/22	Dung Nguyen
C	-----	04/06/23	Kapilan
D	-----	07/22/25	Kapilan



Renesas
603 March RD
Kanata, ON K2K 2M5

Title: HW10120_FC3_RC32308A_QFN48_RevD

Size B	HW Number: HW10120	Engineer: Kapilan Ramachandran	Rev. D
	Date: 07/23/2025	Sheet: 2 of 5	

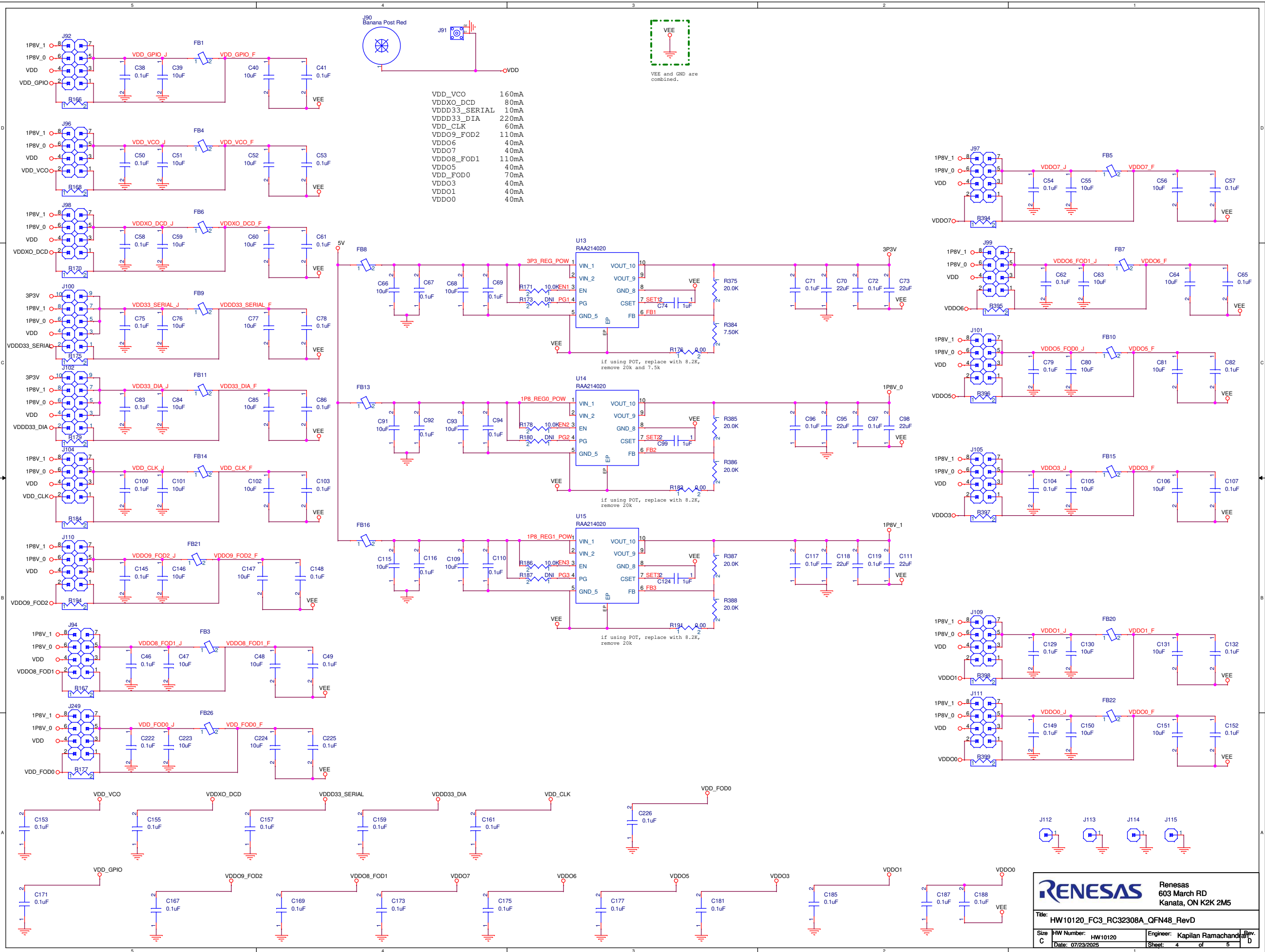

RENESAS Renesas
 603 March RD
 Kanata, ON K2K 2M5

Title: HW10120_FC3_RC32308A_QFN48_RevD

Size	HW Number: HW10120	Engineer: Kapil Ramachandran
C	Date: 07/23/2025	Sheet: 4 of 5

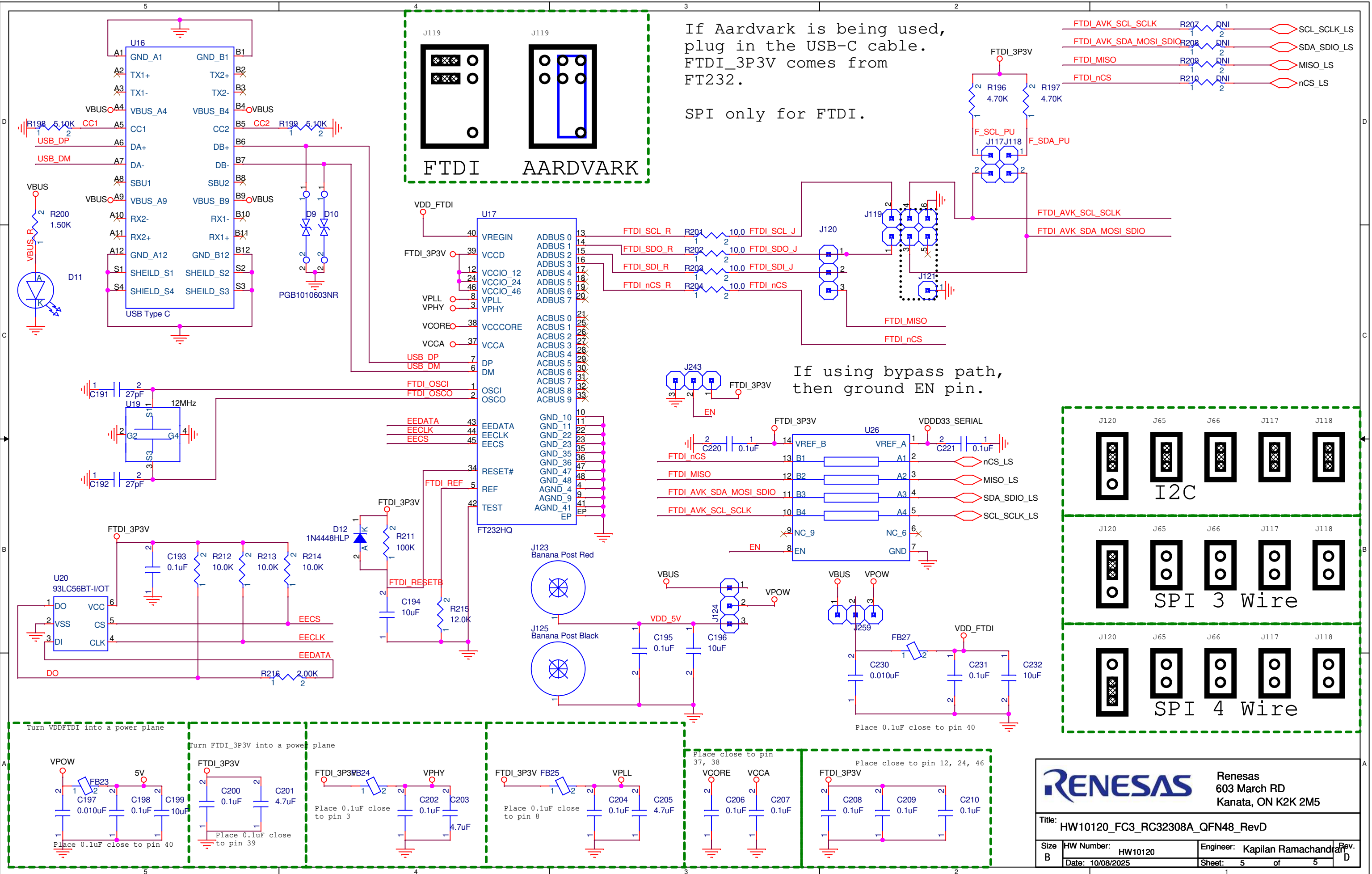

If Aardvark is being used, plug in the USB-C cable. FTDI_3P3V comes from FT232.

SPI only for FTDI.

If using bypass path, then ground EN pin.

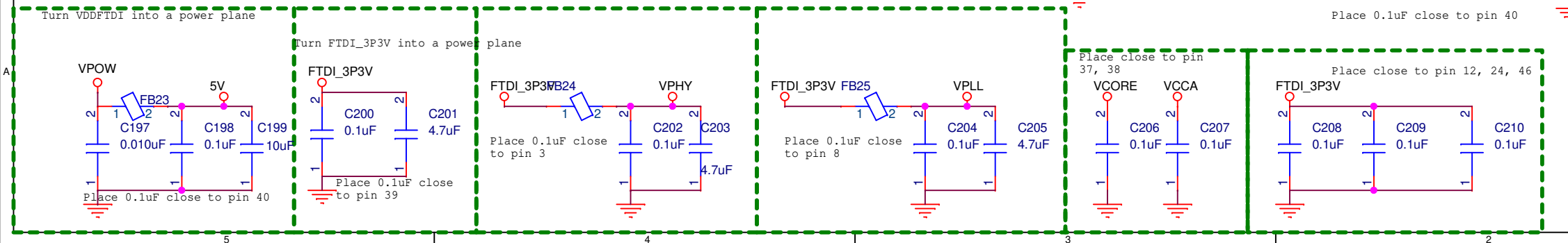
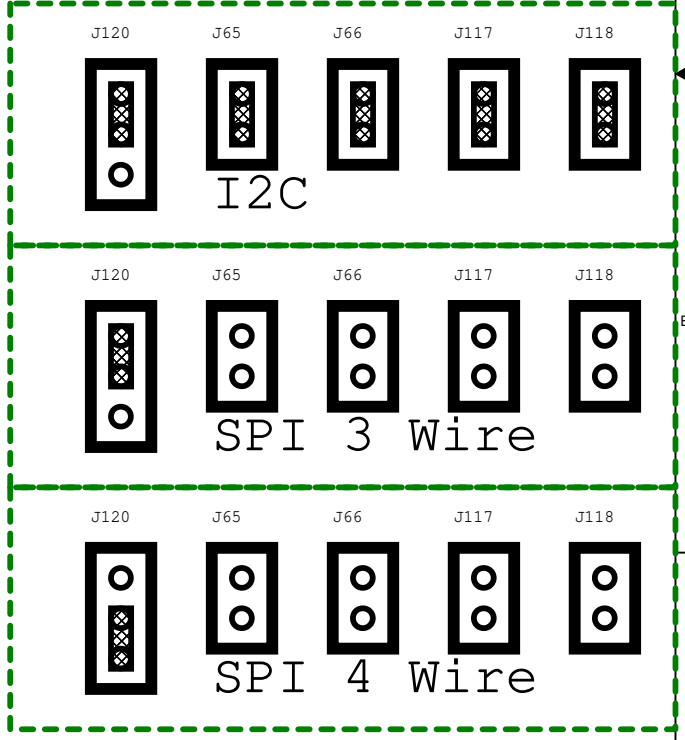
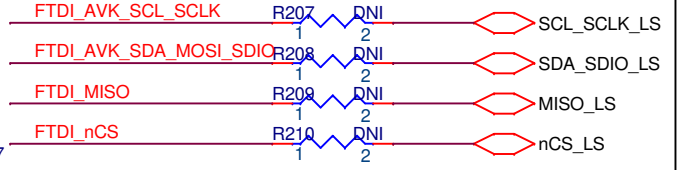

RENESAS Renesas
603 March RD
Kanata, ON K2K 2M5

Title: HW10120_FC3_RC32308A_QFN48_RevD

Size B	HW Number: HW10120	Engineer: Kapilan Ramachandran	Rev. D
	Date: 10/08/2025	Sheet: 5 of 5	