

C7, C10, C11, C14, C15  
 C18, C19 and C22 are  
 U2J dielectric capacitors.

Title		
FemtoClock2 Evaluation Board		
Size	Document Number	Rev
B	RC32514A_EVB_REV-A	A
Date:	Tuesday, April 14, 2020	Sheet 2 of 4

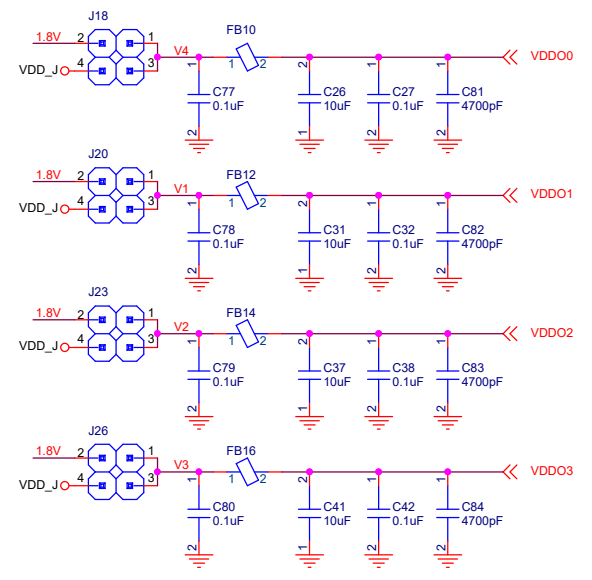

C81, C82, C83 and C84 are U2J dielectric capacitors.

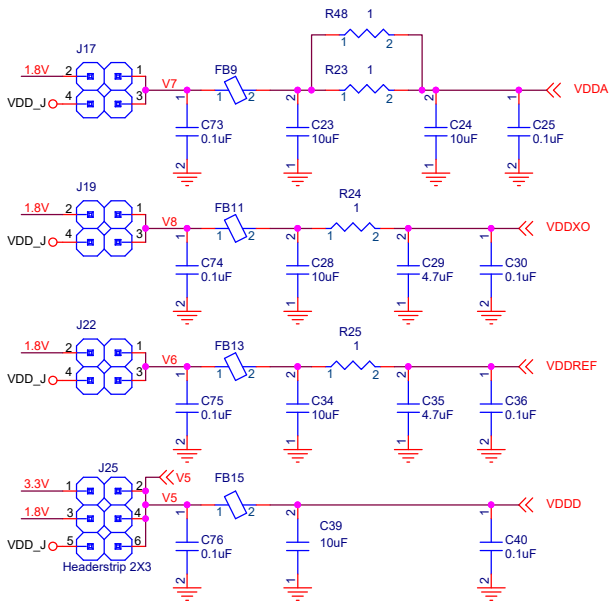
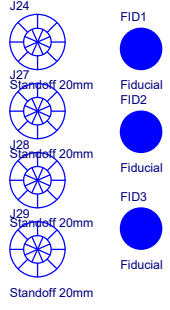
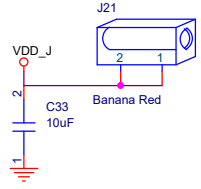
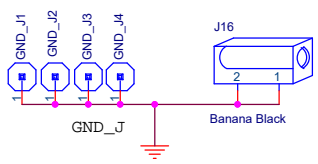
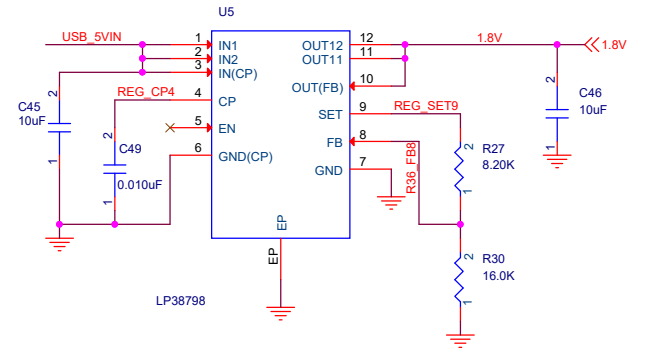
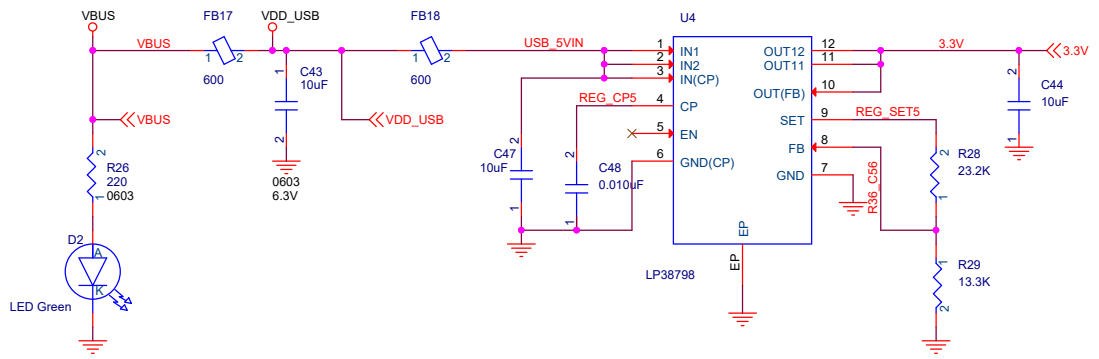

Title		
FemtoClock2 Evaluation Board		
Size	Document Number	Rev
B	RC32514A_EVB_REV-A	A
Date:	Friday, April 17, 2020	Sheet 3 of 4

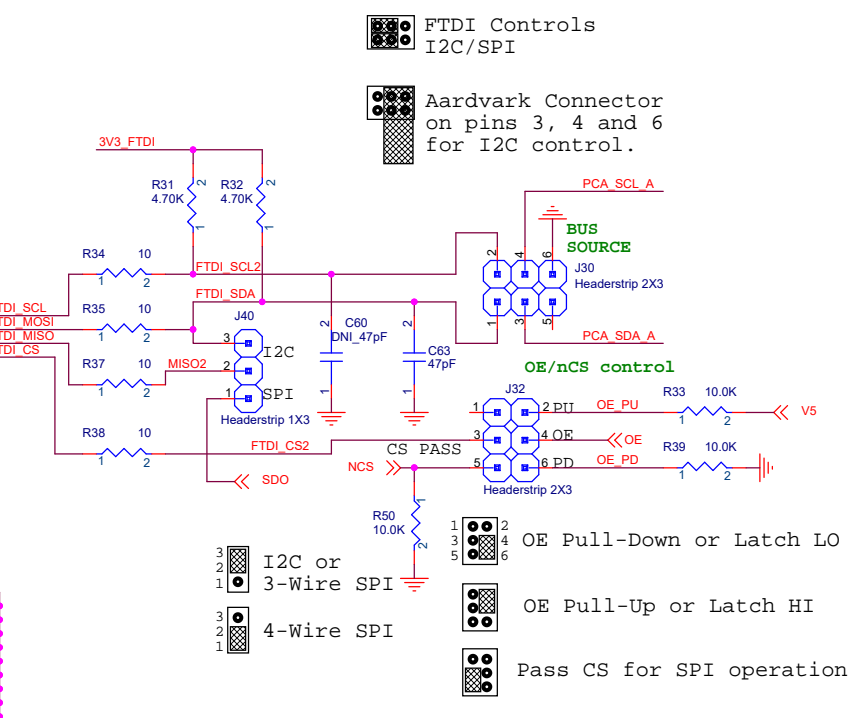
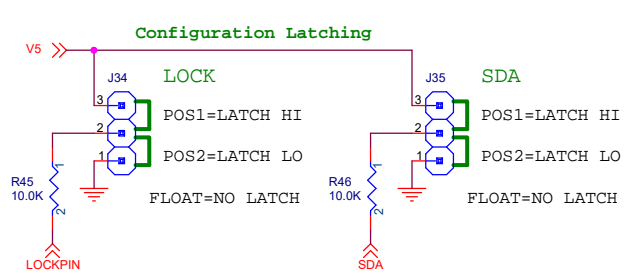
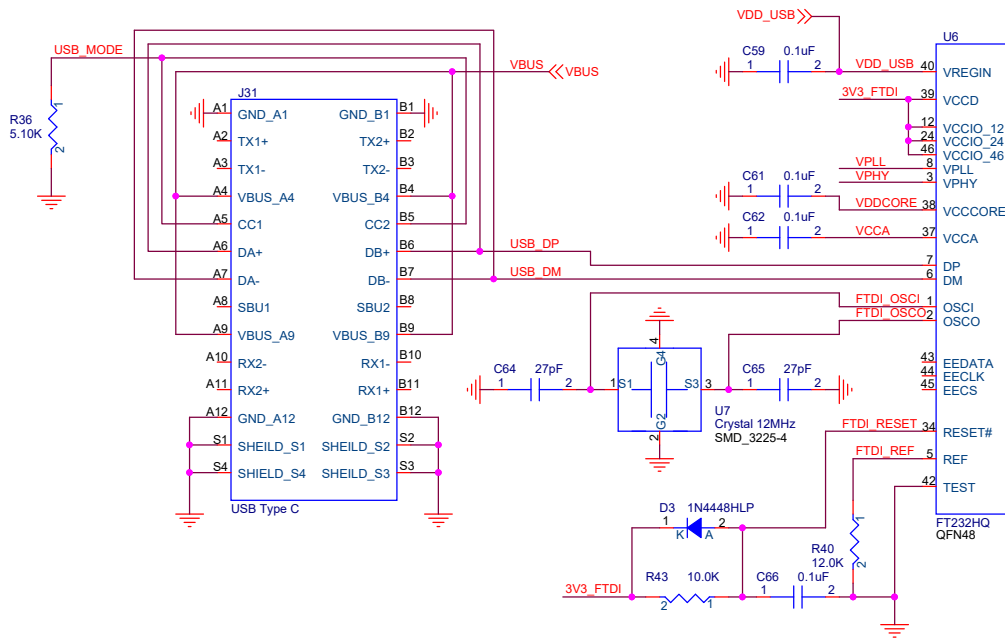
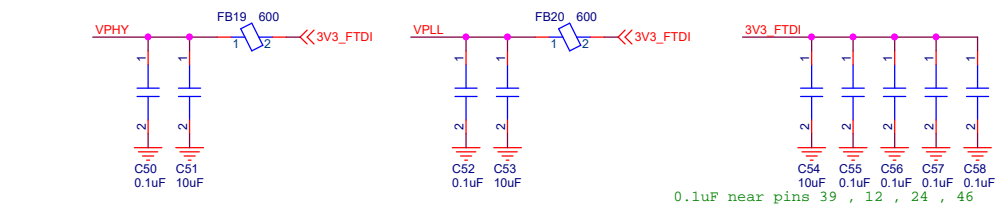

- I2C or 3-Wire SPI
- 3-Wire SPI
- 4-Wire SPI
- OE Pull-Down or Latch LO
- OE Pull-Up or Latch HI
- Pass CS for SPI operation

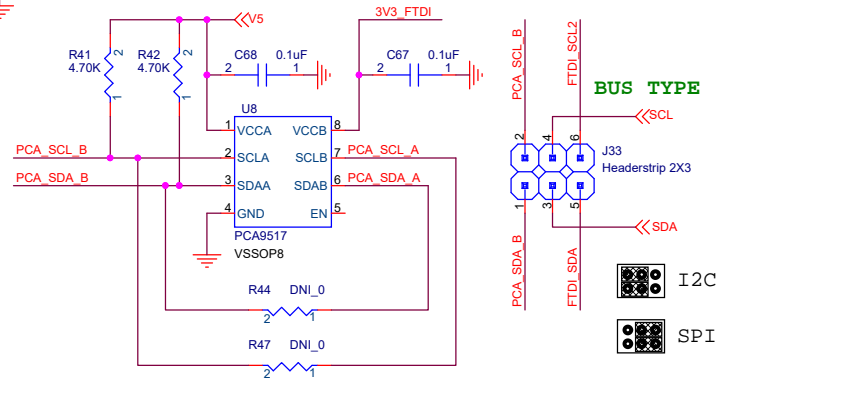

Assemble R44 and R47 when not assembling U9.

Title		
FemtoClock2 Evaluation Board		
Size B	Document Number RC32514A_EVB_REV-A	Rev A
Date:	Thursday, April 16, 2020	Sheet 4 of 4