

REVISIONS				
DCN	REV	DESCRIPTION	DATE	CHANGE BY
	1.0	INITIAL RELEASE	2009-12-05	T. TRAN

1. TITLE PAGE / TABLE OF CONTENTS

- | | |
|---------------------------------------|--|
| 2. SAS CONNECTOR PORTS 0-7 | 22. POWER CONNECTORS, MIN LOAD RESISTORS |
| 3. MEZZANINE CONNECTOR PORTS 8, 12 | 23. POWER REGULATOR - VDDIO |
| 4. MEZZANINE CONNECTOR PORTS 16, 20 | 24. POWER REGULATOR - VDDCORE |
| 5. 24NT24G2 - SERDES | 25. POWER REGULATOR - VDDPEA |
| 6. 24NT24G2 - CLK, CONFIG, GPIO | 26. POWER REGULATOR - VDDPEHA |
| 7. 24NT24G2 - POWER, GND | 27. POWER REGULATOR - VDDPETA |
| 8. IOEXPANDER 0-3 | 28. RESET, SMBUS, EEPROM, JTAG |
| 9. IOEXPANDER 4-7 | 29. DIP SWITCHES |
| 10. IOEXPANDER 8-11 | 30. LED - PORT STATUS (1 OF 7) |
| 11. IOEXPANDER 12-13 | 31. LED - PORT STATUS (2 OF 7) |
| 12. IOEXPANDER 16-19 | 32. LED - PORT STATUS (3 OF 7) |
| 13. IOEXPANDER 20-21 | 33. LED - PORT STATUS (4 OF 7) |
| 14. HOT PLUG CONTROL PORTS 8-12 | 34. LED - PORT STATUS (5 OF 7) |
| 15. HOT PLUG CONTROL PORTS 16-20 | 35. LED - PORT STATUS (6 OF 7) |
| 16. SLOT RESETS AND WAKE PULL-UPS | 36. LED - PORT STATUS (7 OF 7) |
| 17. CLOCK | 37. 12PK RIBBON CONNECTORS |
| 18. CLOCK BUFFER | 38. PARTITION RESET SELECT HEADERS |
| 19. CLOCK SELECTOR - DUT PCLK 8 | 39. SLOT RESET SELECT HEADERS |
| 20. CLOCK SELECTOR - DUT PCLK 16 | 40. PORT 8 CLOCK GENERATOR |
| 21. CLOCK SELECTOR - SLOTS 0-20, GCLK | 41. PORT 16 CLOCK GENERATOR |



CONFIDENTIAL PROPERTY OF INTEGRATED DEVICE TECHNOLOGY, INC.
 6024 SILVER CREEK VALLEY RD. SAN JOSE, CA 95138
 COPYRIGHT (C) 2010

TITLE EB-LOGAN-19			
SIZE B	DRAWING NO. SCH-PESEB-002	FAB P/N 18-692-001	REV. 2.0
AUTHOR Tony Tran		CHECKED BY Derek Huang	
Thu Jun 10 11:24:42 2010			SHEET 1 OF 41

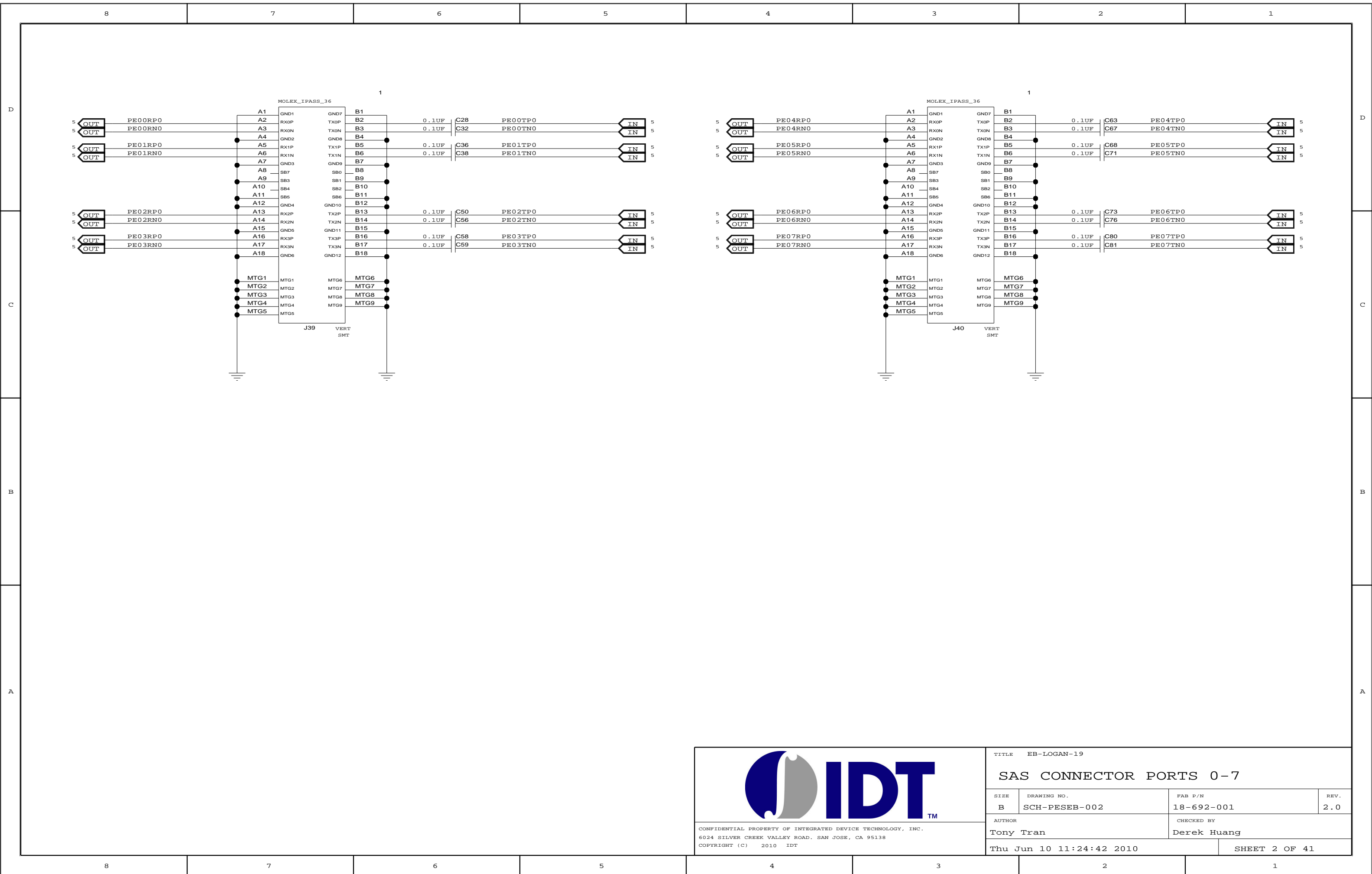

		TITLE EB-LOGAN-19		
		SAS CONNECTOR PORTS 0-7		
SIZE	DRAWING NO.	FAB P/N	REV.	
B	SCH-PESEB-002	18-692-001	2.0	
AUTHOR		CHECKED BY		
Tony Tran		Derek Huang		
Thu Jun 10 11:24:42 2010			SHEET 2 OF 41	

CONFIDENTIAL PROPERTY OF INTEGRATED DEVICE TECHNOLOGY, INC.
6024 SILVER CREEK VALLEY ROAD. SAN JOSE, CA 95138
COPYRIGHT (C) 2010 IDT

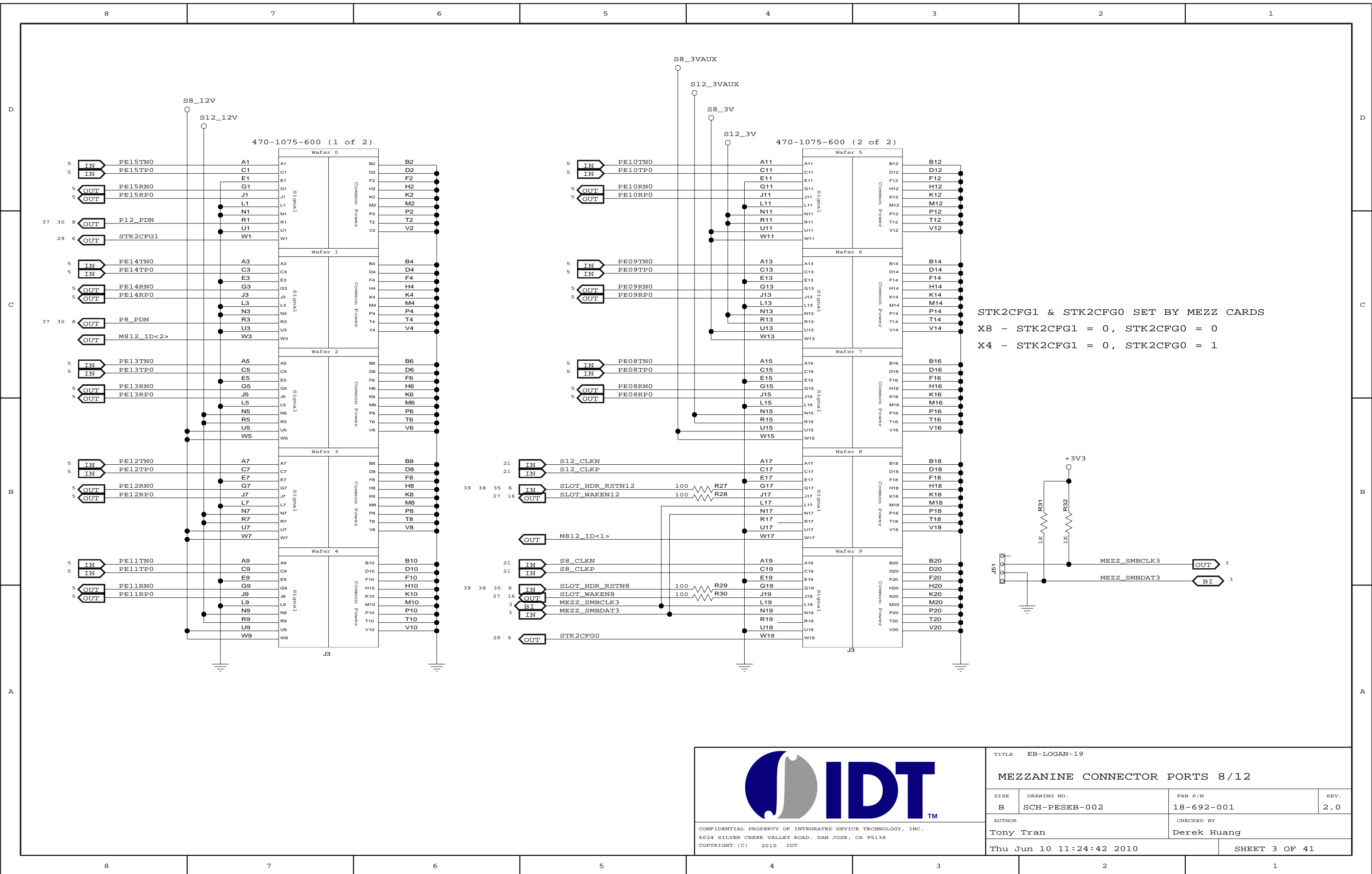

STK2CFG1 & STK2CFG0 SET BY MEZZ CARDS
 X8 - STK2CFG1 = 0, STK2CFG0 = 0
 X4 - STK2CFG1 = 0, STK2CFG0 = 1



CONFIDENTIAL PROPERTY OF INTEGRATED DEVICE TECHNOLOGY, INC.
 6024 SILVER CREEK VALLEY ROAD, SAN JOSE, CA 95138
 COPYRIGHT (C) 2010 IDT

TITLE EB-LOGAN-19			
MEZZANINE CONNECTOR PORTS 8/12			
SIZE B	DRAWING NO. SCH-PESEB-002	FAB P/N 18-692-001	REV. 2.0
AUTHOR Tony Tran		CHECKED BY Derek Huang	
Thu Jun 10 11:24:42 2010			SHEET 3 OF 41

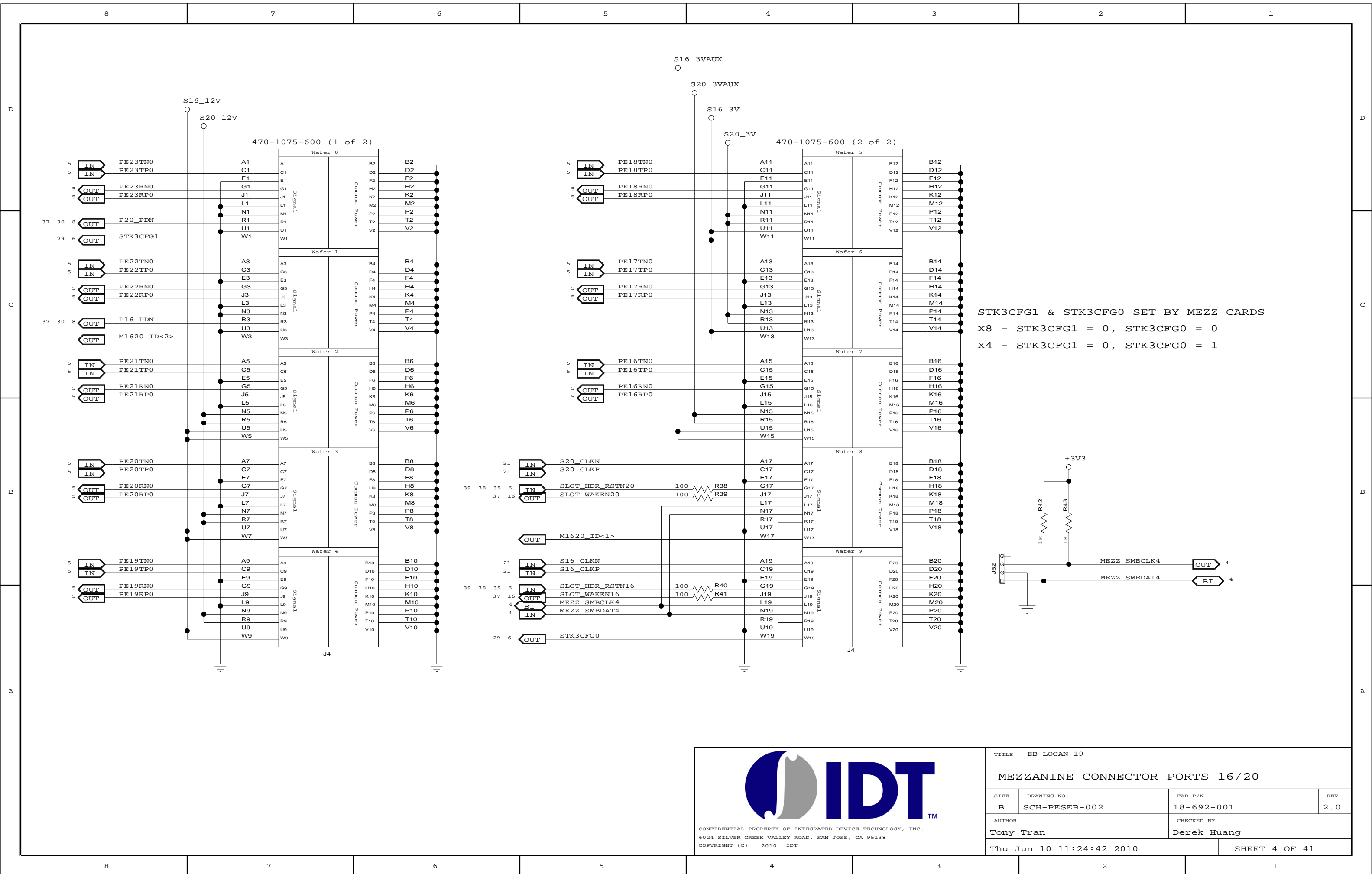



STK3CFG1 & STK3CFG0 SET BY MEZZ CARDS
 X8 - STK3CFG1 = 0, STK3CFG0 = 0
 X4 - STK3CFG1 = 0, STK3CFG0 = 1

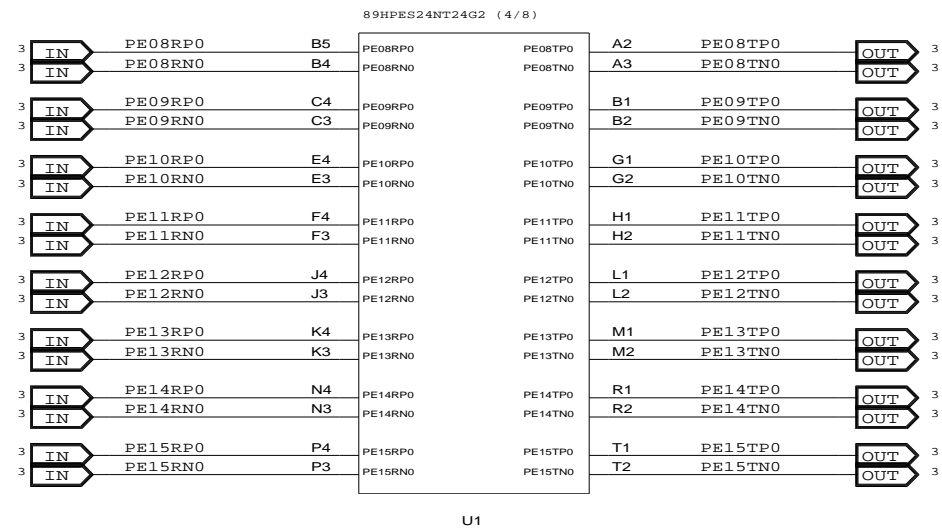
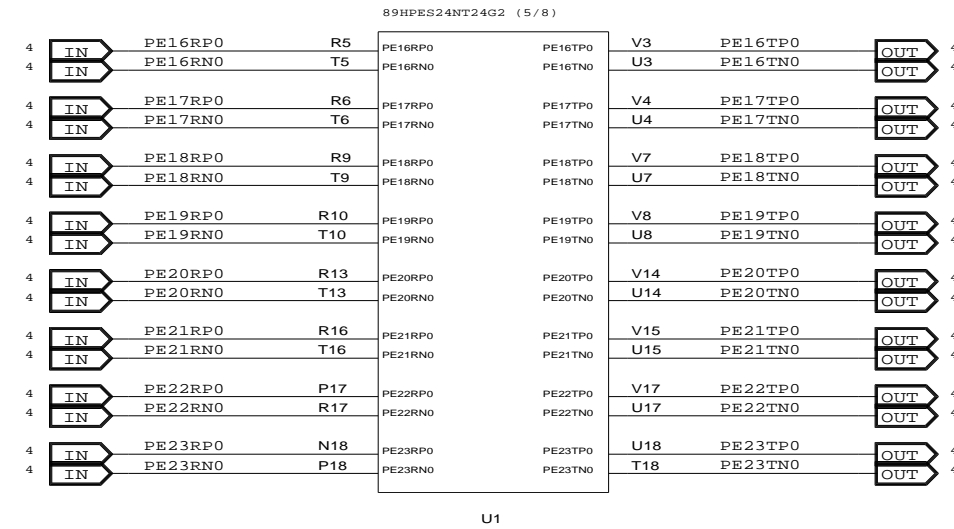
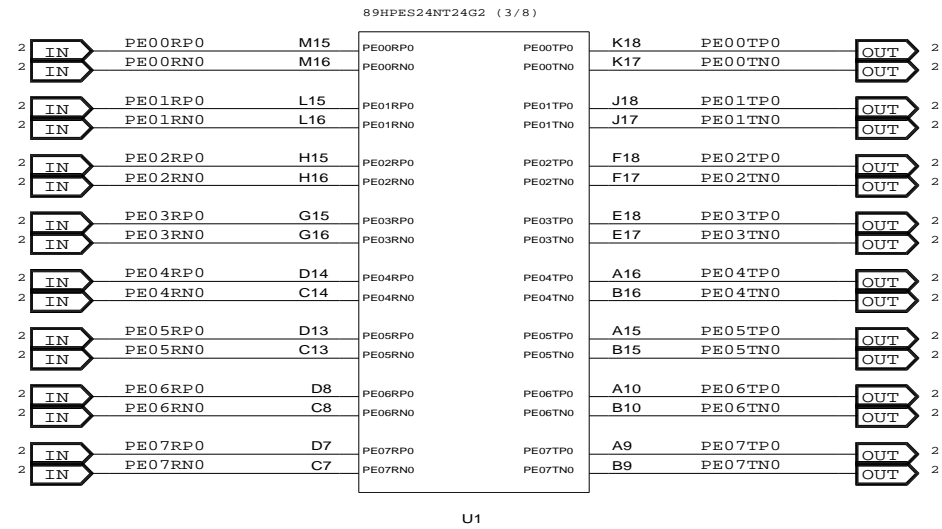

CONFIDENTIAL PROPERTY OF INTEGRATED DEVICE TECHNOLOGY, INC.
 6024 SILVER CREEK VALLEY ROAD, SAN JOSE, CA 95138
 COPYRIGHT (C) 2010 IDT

TITLE EB-LOGAN-19			
MEZZANINE CONNECTOR PORTS 16/20			
SIZE	DRAWING NO.	FAB P/N	REV.
B	SCH-PESEB-002	18-692-001	2.0
AUTHOR		CHECKED BY	
Tony Tran		Derek Huang	
Thu Jun 10 11:24:42 2010			SHEET 4 OF 41



	TITLE EB-LOGAN-19		
	24NT24G2 - SERDES		
SIZE	DRAWING NO.	FAB P/N	REV.
B	SCH-PESEB-002	18-692-001	2.0
AUTHOR		CHECKED BY	
Tony Tran		Derek Huang	
Thu Jun 10 11:24:43 2010			SHEET 5 OF 41

CONFIDENTIAL PROPERTY OF INTEGRATED DEVICE TECHNOLOGY, INC.
6024 SILVER CREEK VALLEY ROAD. SAN JOSE, CA 95138
COPYRIGHT (C) 2010 IDT

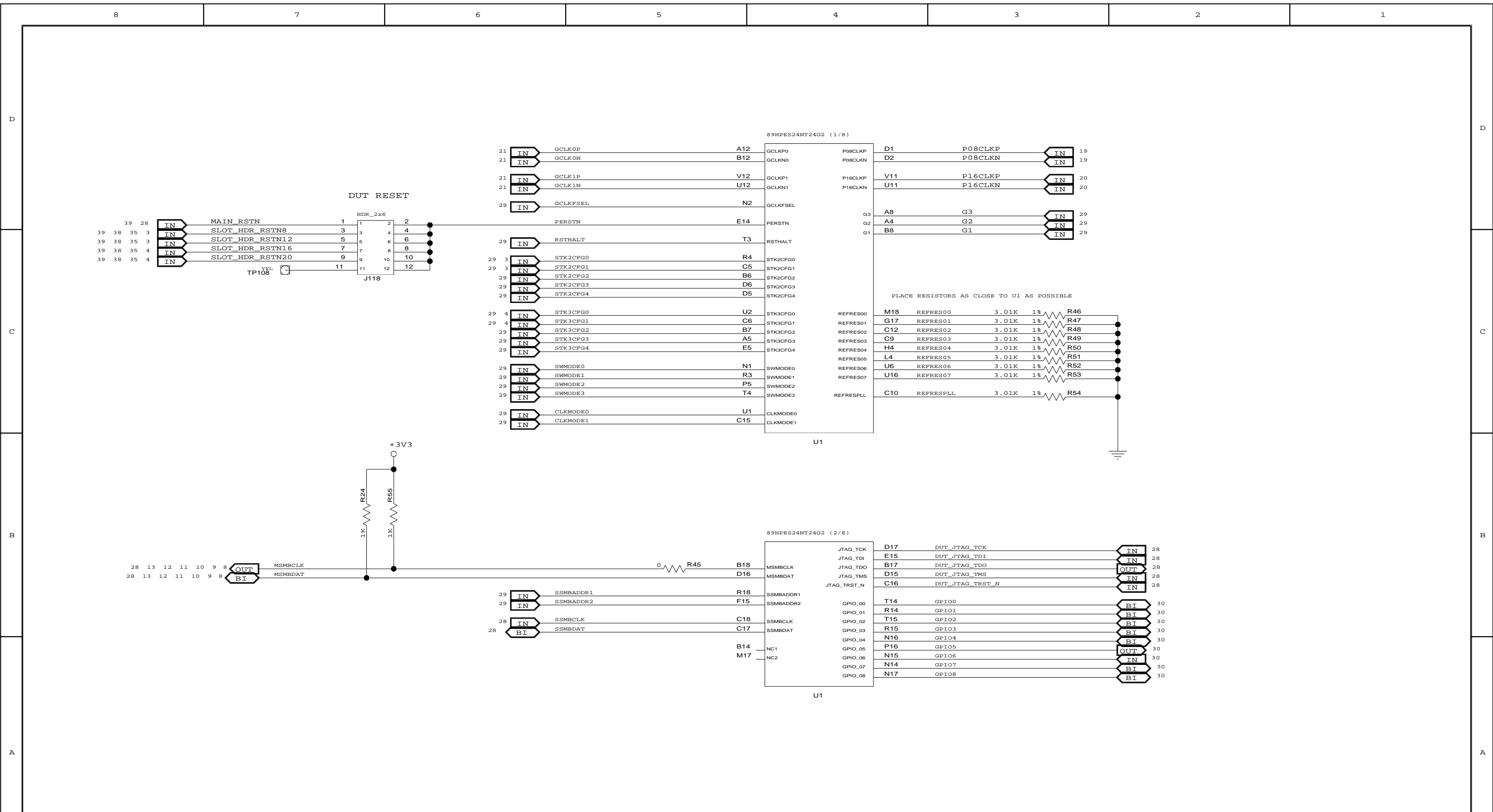

		TITLE EB-LOGAN-19		
		24NT24G2 - CLK, CONFIG, GPIO		
SIZE	DRAWING NO.	FAB P/N	REV.	
B	SCH-PESEB-002	18-692-001	2.0	
AUTHOR		CHECKED BY		
Tony Tran		Derek Huang		
Thu Jun 10 11:24:43 2010			SHEET 6 OF 41	

CONFIDENTIAL PROPERTY OF INTEGRATED DEVICE TECHNOLOGY, INC.
6024 SILVER CREEK VALLEY ROAD. SAN JOSE, CA 95138
COPYRIGHT (C) 2010 IDT

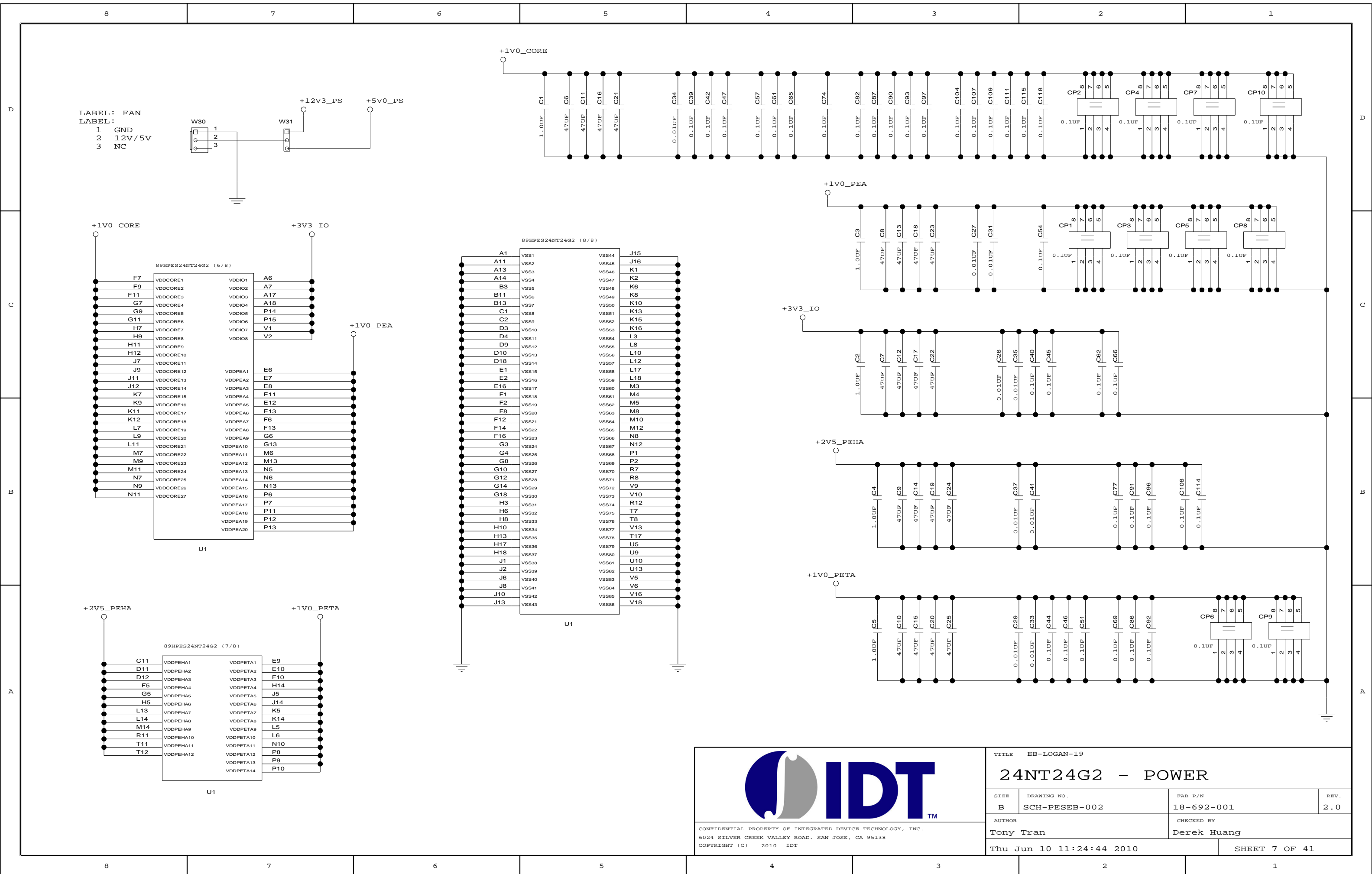

LABEL: FAN
 LABEL:
 1 GND
 2 12V/5V
 3 NC



+12V3_PS
 +5V0_PS

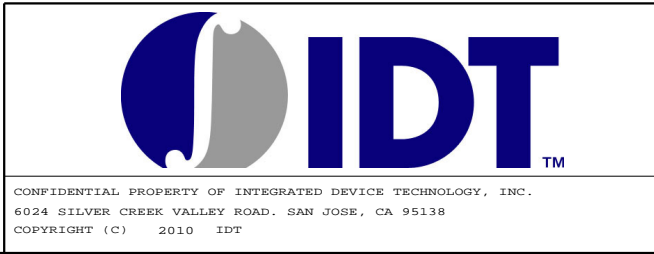
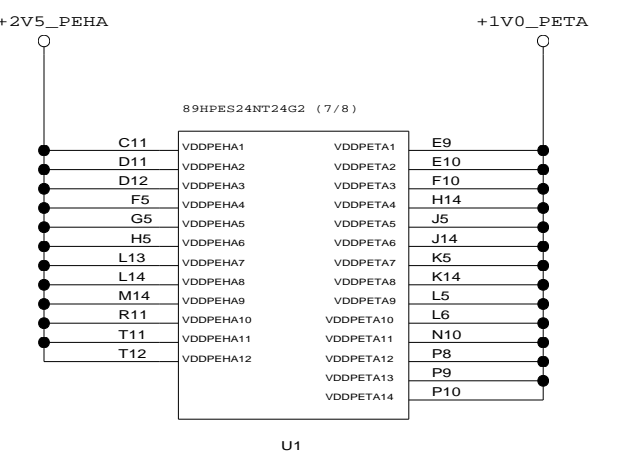
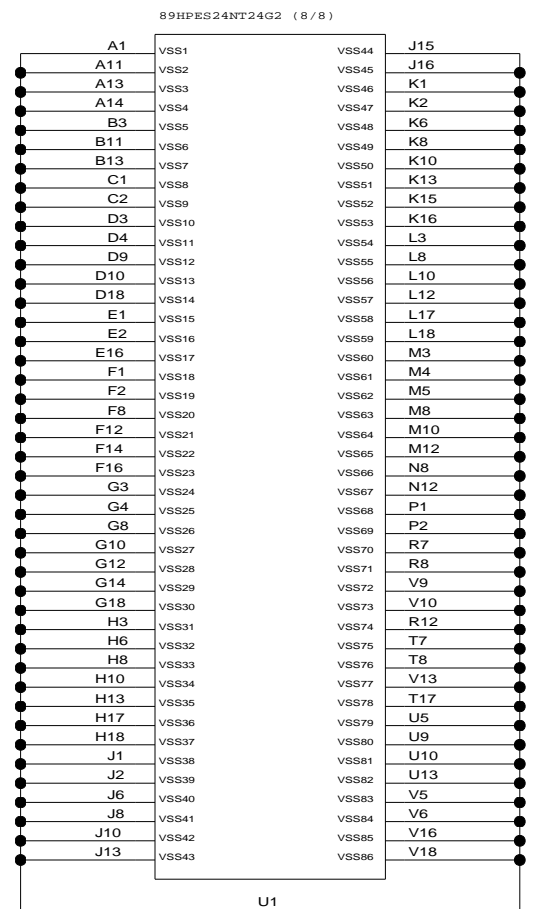
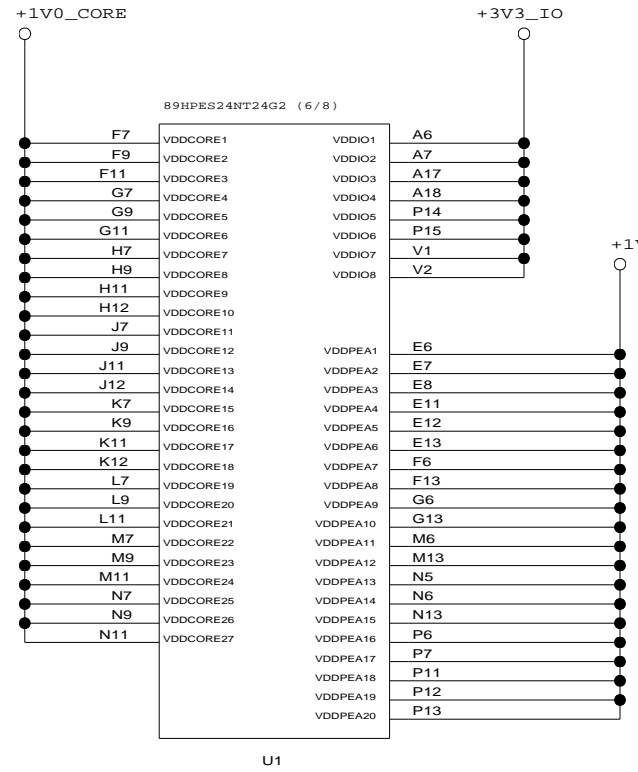

TITLE EB-LOGAN-19			
24NT24G2 - POWER			
SIZE B	DRAWING NO. SCH-PESEB-002	FAB P/N 18-692-001	REV. 2.0
AUTHOR Tony Tran		CHECKED BY Derek Huang	
Thu Jun 10 11:24:44 2010			SHEET 7 OF 41

D

D

C

C

B

B

A

A

PLACE RESISTORS ON CLOSE AND ON SAME SIDE OF BOARD

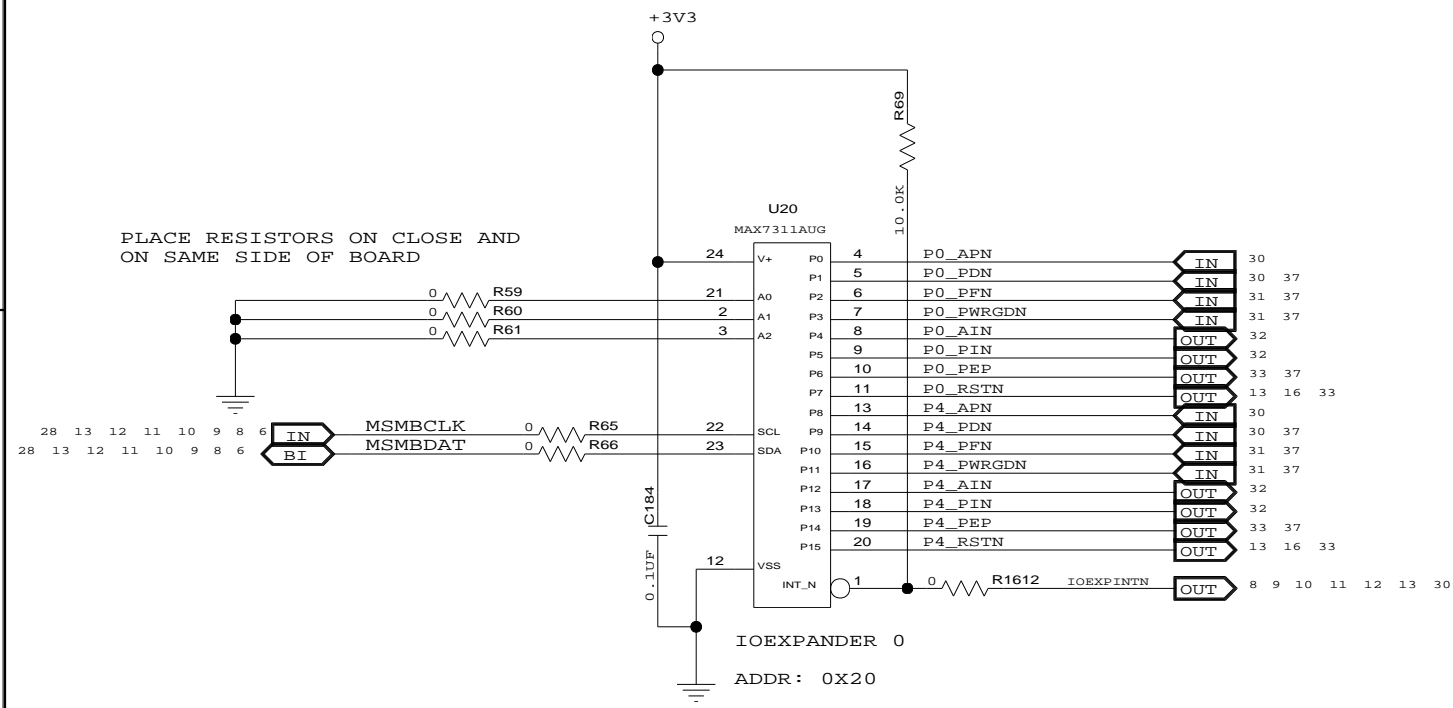

PLACE RESISTORS ON CLOSE AND ON SAME SIDE OF BOARD

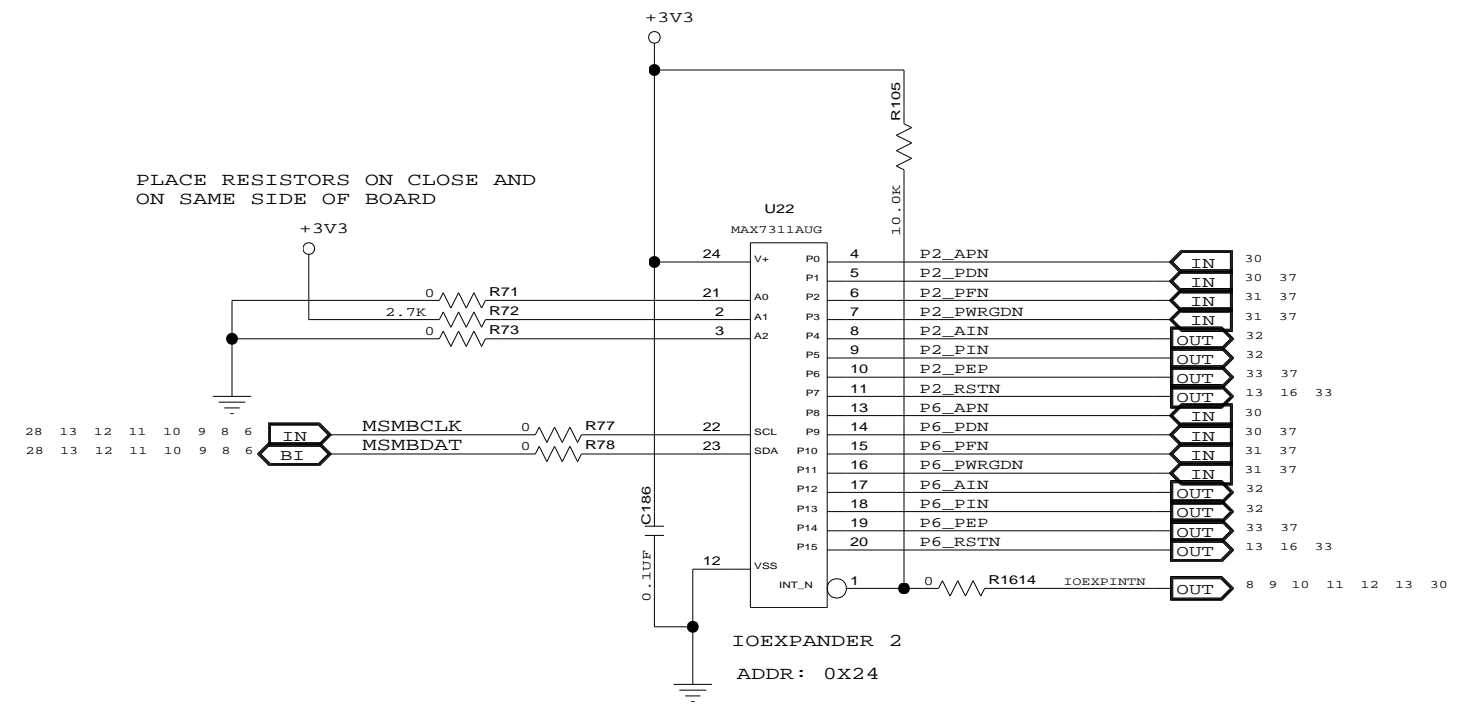

PLACE RESISTORS ON CLOSE AND ON SAME SIDE OF BOARD

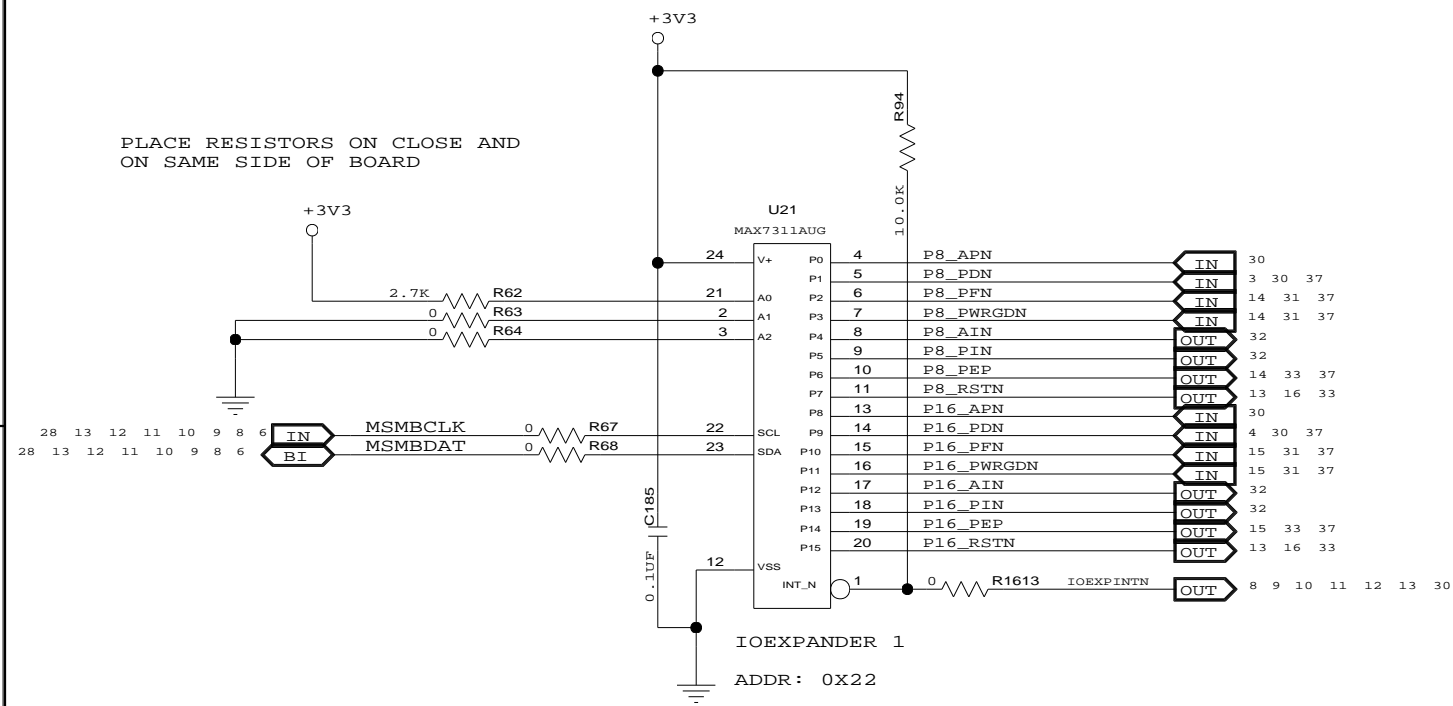

PLACE RESISTORS ON CLOSE AND ON SAME SIDE OF BOARD

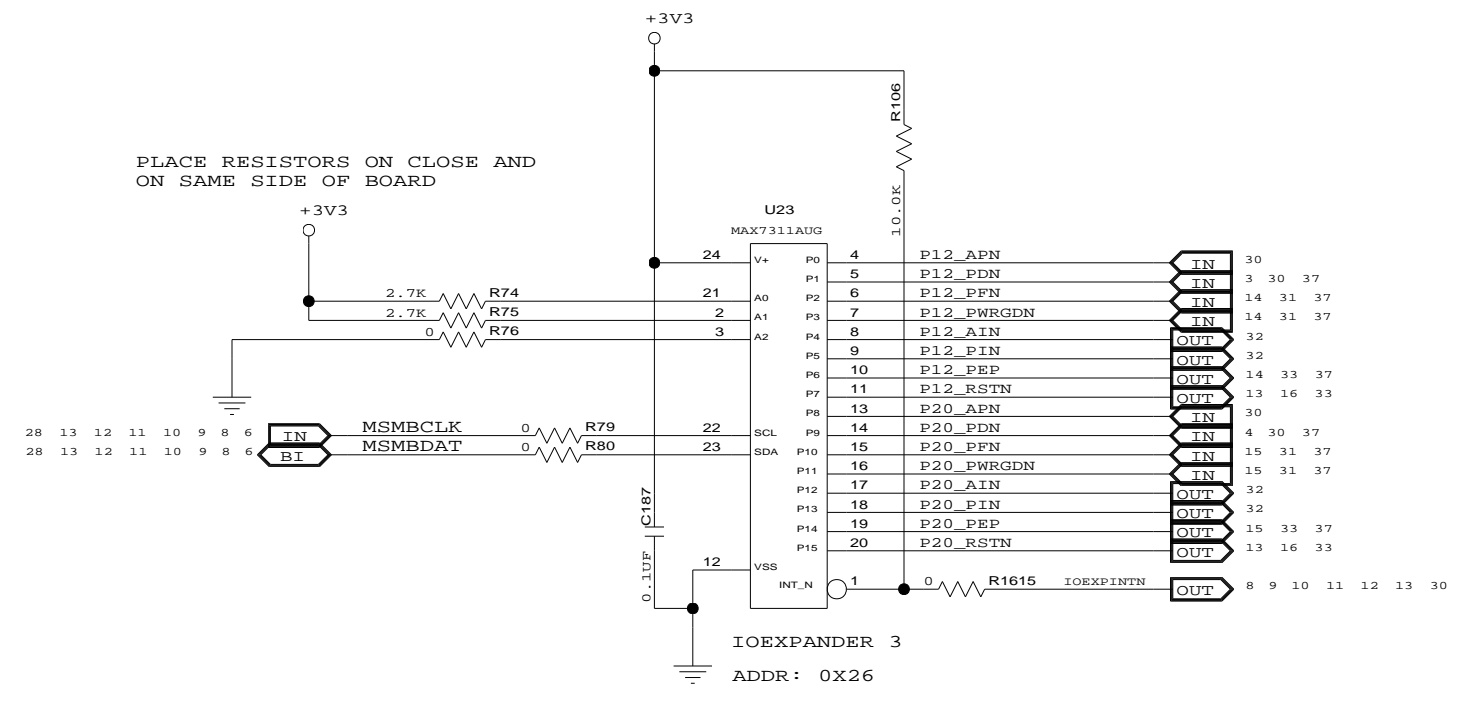



CONFIDENTIAL PROPERTY OF INTEGRATED DEVICE TECHNOLOGY, INC.
6024 SILVER CREEK VALLEY ROAD, SAN JOSE, CA 95138
COPYRIGHT (C) 2010 IDT

TITLE EB-LOGAN-19

IOEXPANDER 0-3

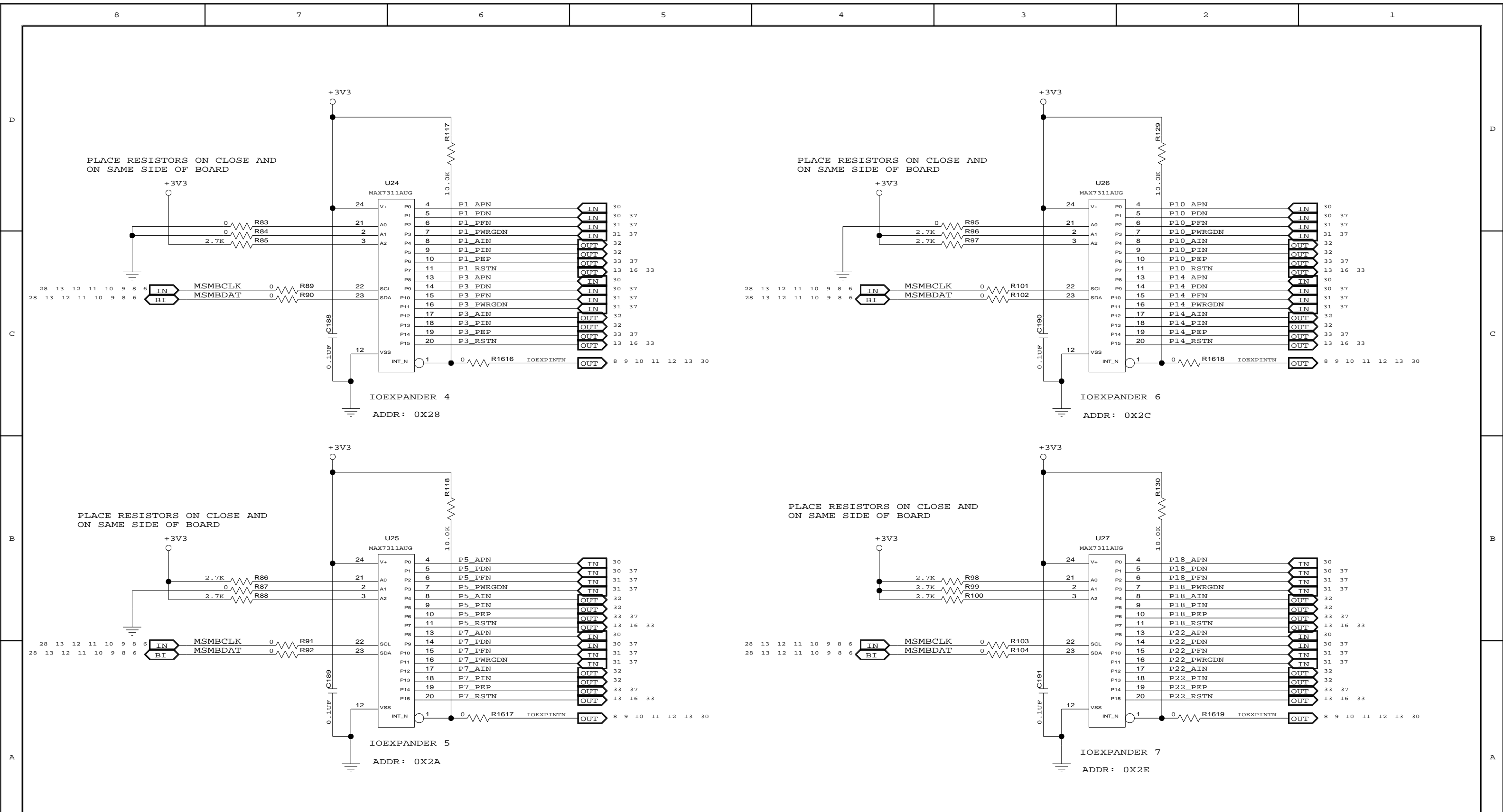
SIZE	DRAWING NO.	FAB P/N	REV.
B	SCH-PESEB-002	18-692-001	2.0
AUTHOR		CHECKED BY	
Tony Tran		Derek Huang	
Thu Jun 10 11:24:44 2010			SHEET 8 OF 41





CONFIDENTIAL PROPERTY OF INTEGRATED DEVICE TECHNOLOGY, INC.
 6024 SILVER CREEK VALLEY ROAD, SAN JOSE, CA 95138
 COPYRIGHT (C) 2010 IDT

TITLE EB-LOGAN-19

IOEXPANDER 4-7

SIZE	DRAWING NO.	FAB P/N	REV.
B	SCH-PESEB-002	18-692-001	2.0
AUTHOR		CHECKED BY	
Tony Tran		Derek Huang	
Thu Jun 10 11:24:45 2010			SHEET 9 OF 41

D

D

PLACE RESISTORS ON CLOSE AND ON SAME SIDE OF BOARD

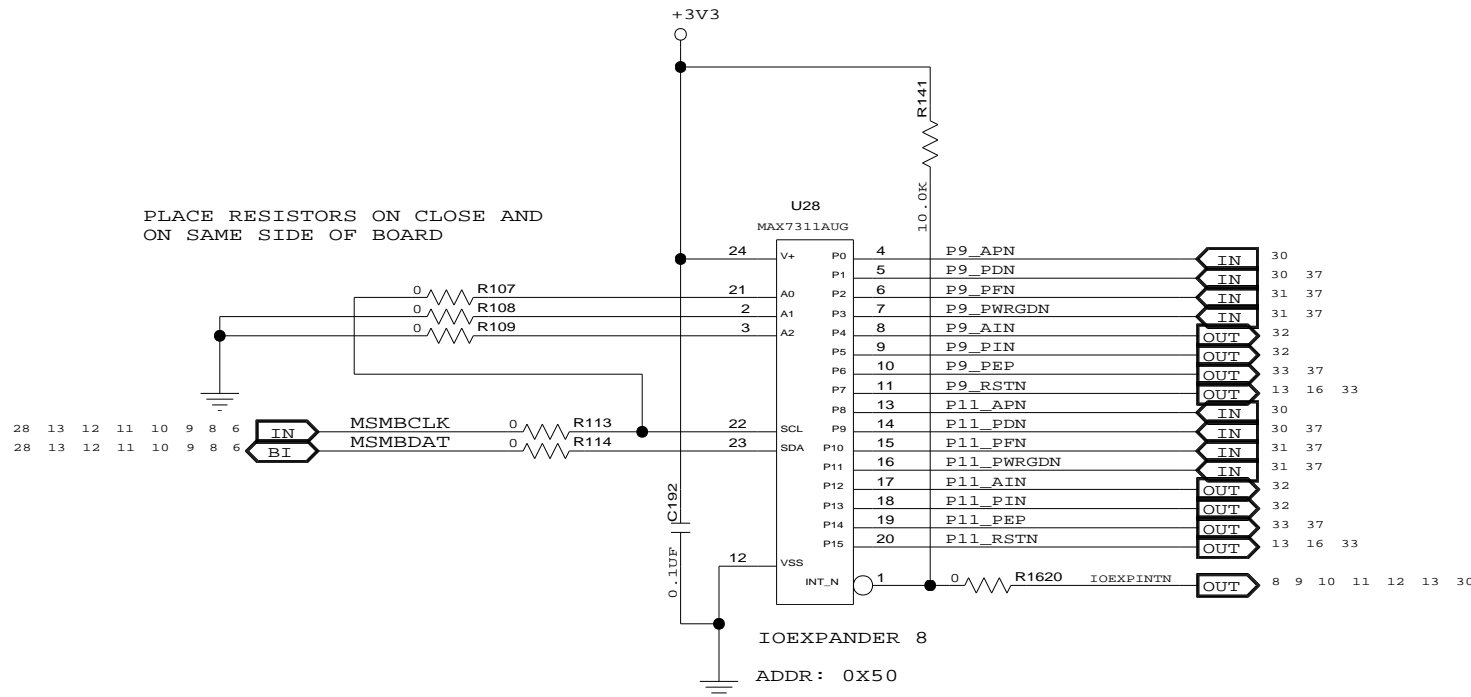

PLACE RESISTORS ON CLOSE AND ON SAME SIDE OF BOARD

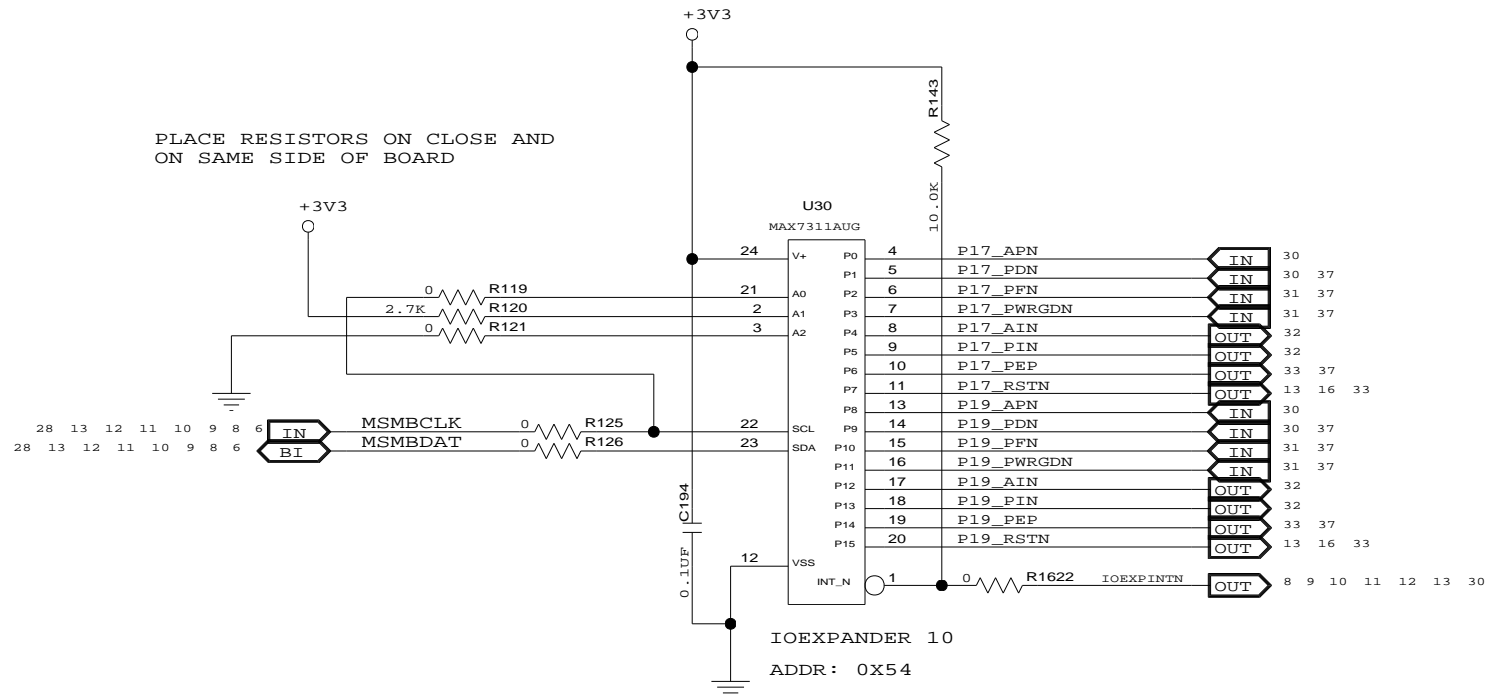

C

C

PLACE RESISTORS ON CLOSE AND ON SAME SIDE OF BOARD

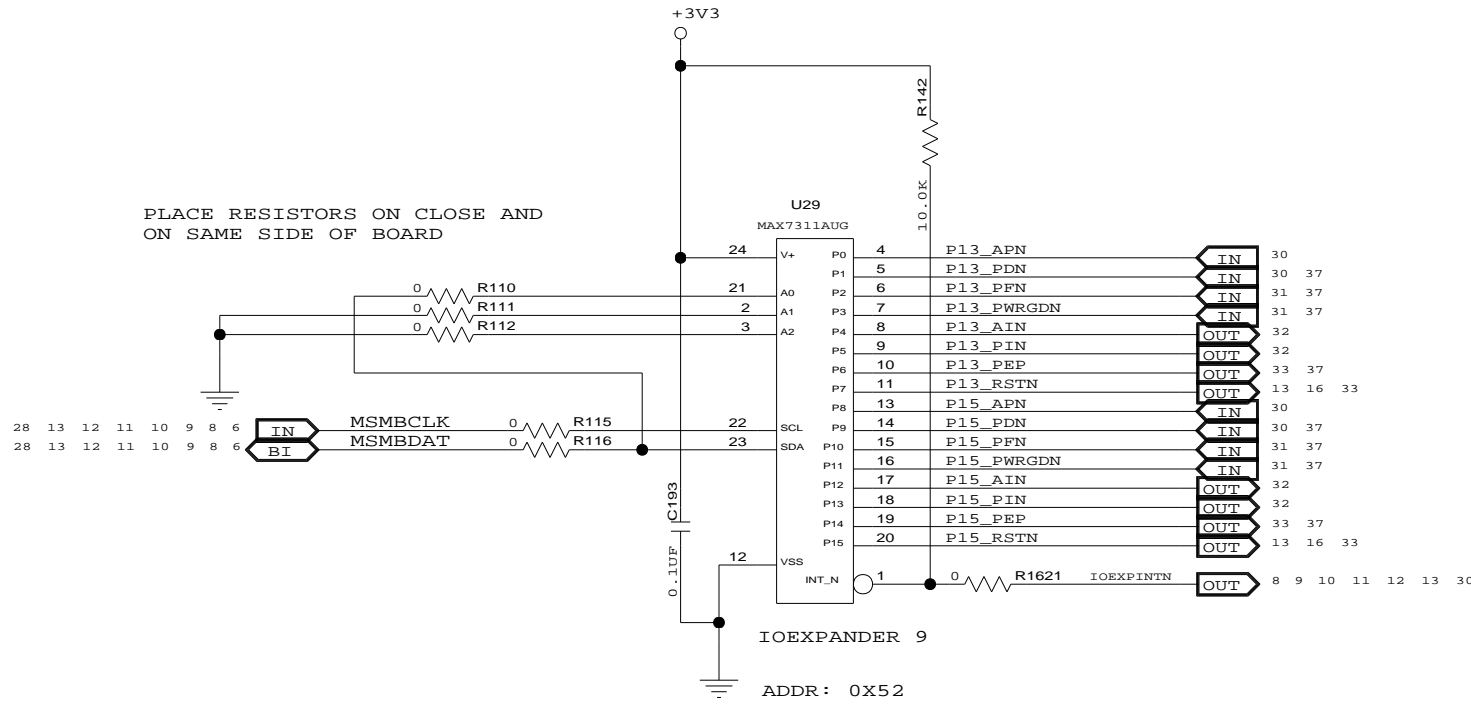

PLACE RESISTORS ON CLOSE AND ON SAME SIDE OF BOARD

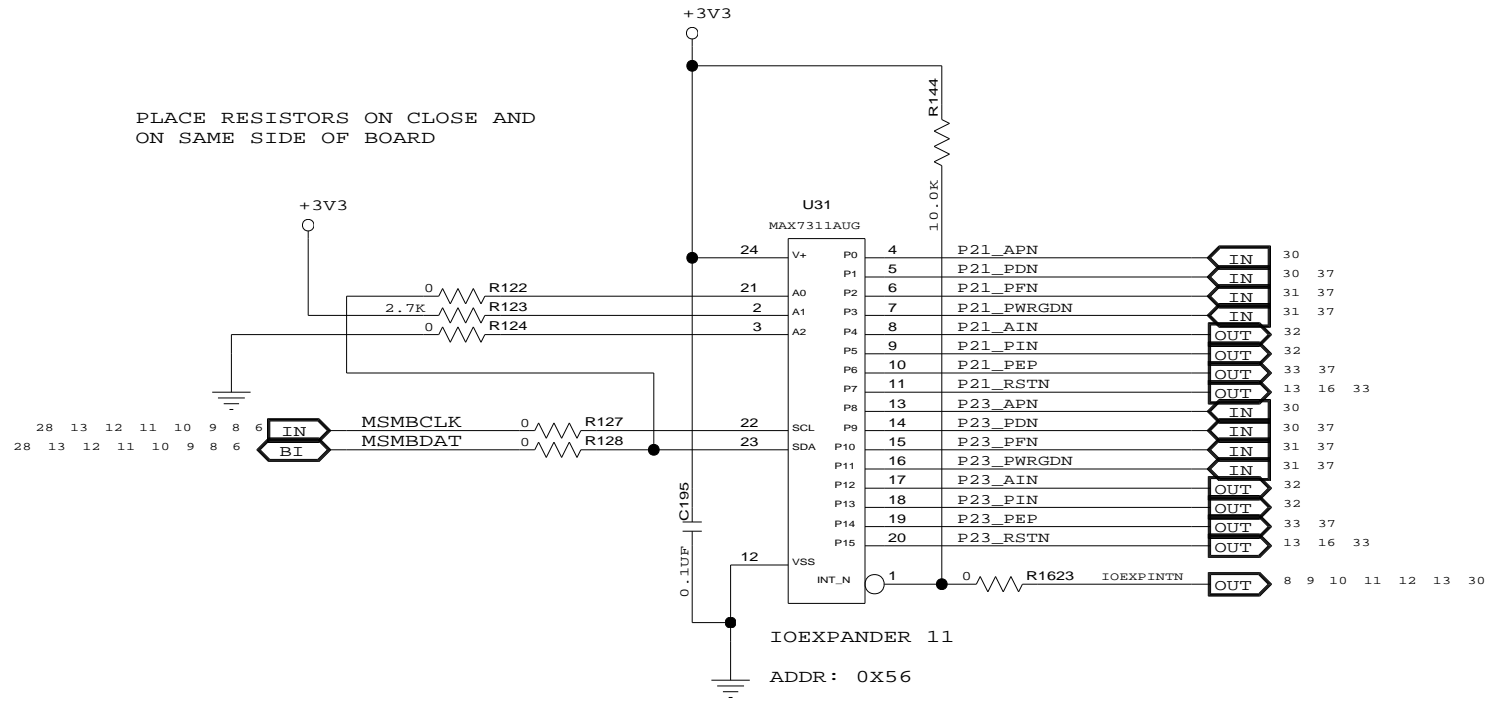

B

B

A

A

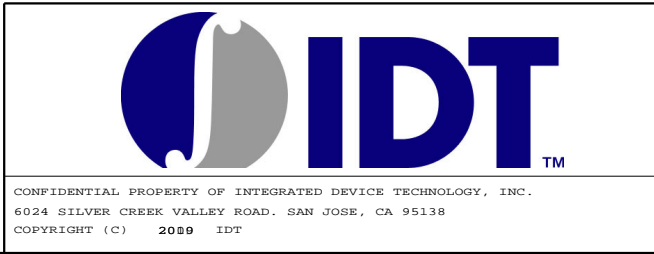

TITLE EB-LOGAN-19			
IOEXPANDER 8-11			
SIZE B	DRAWING NO. SCH-PESEB-002	FAB P/N 18-692-001	REV. 2.0
AUTHOR Tony Tran		CHECKED BY Derek Huang	
Thu Jun 10 11:24:45 2010			SHEET 10 OF 41

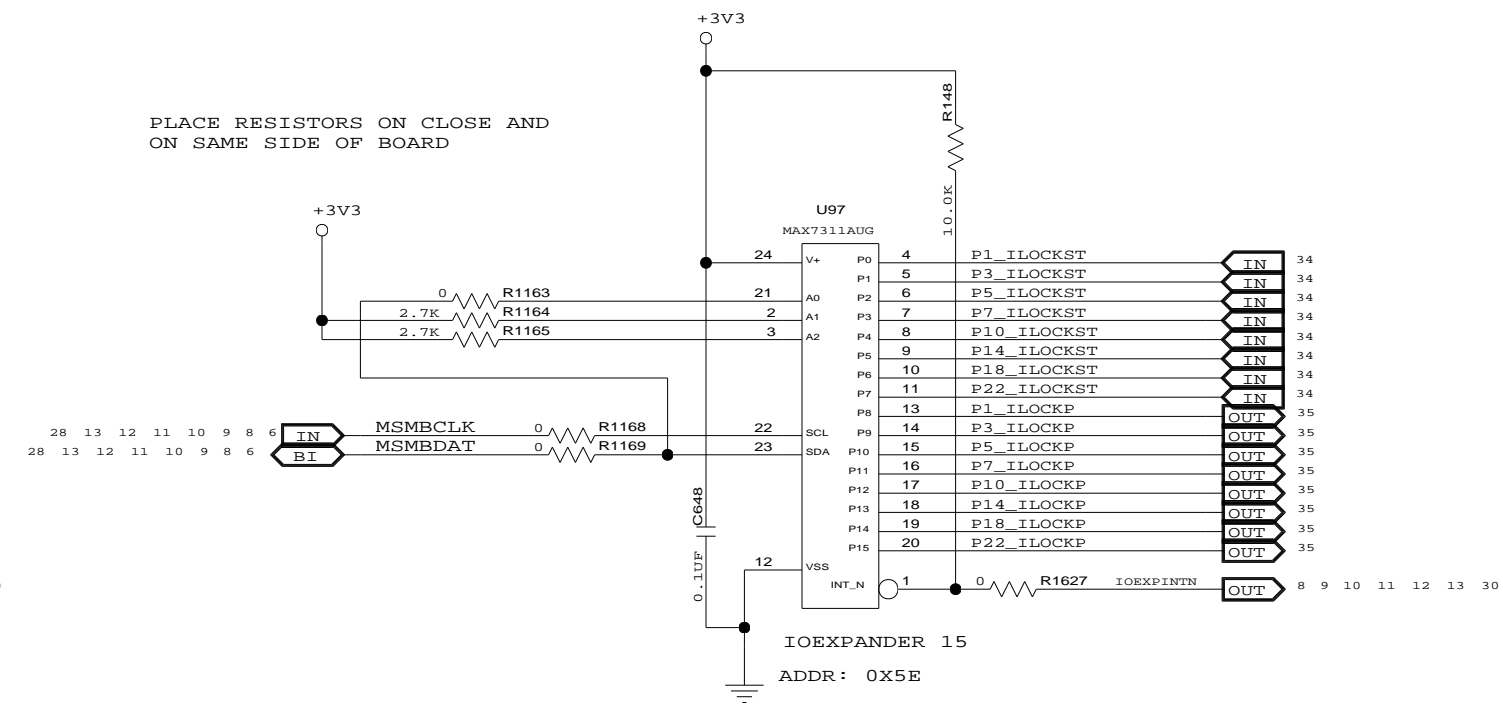
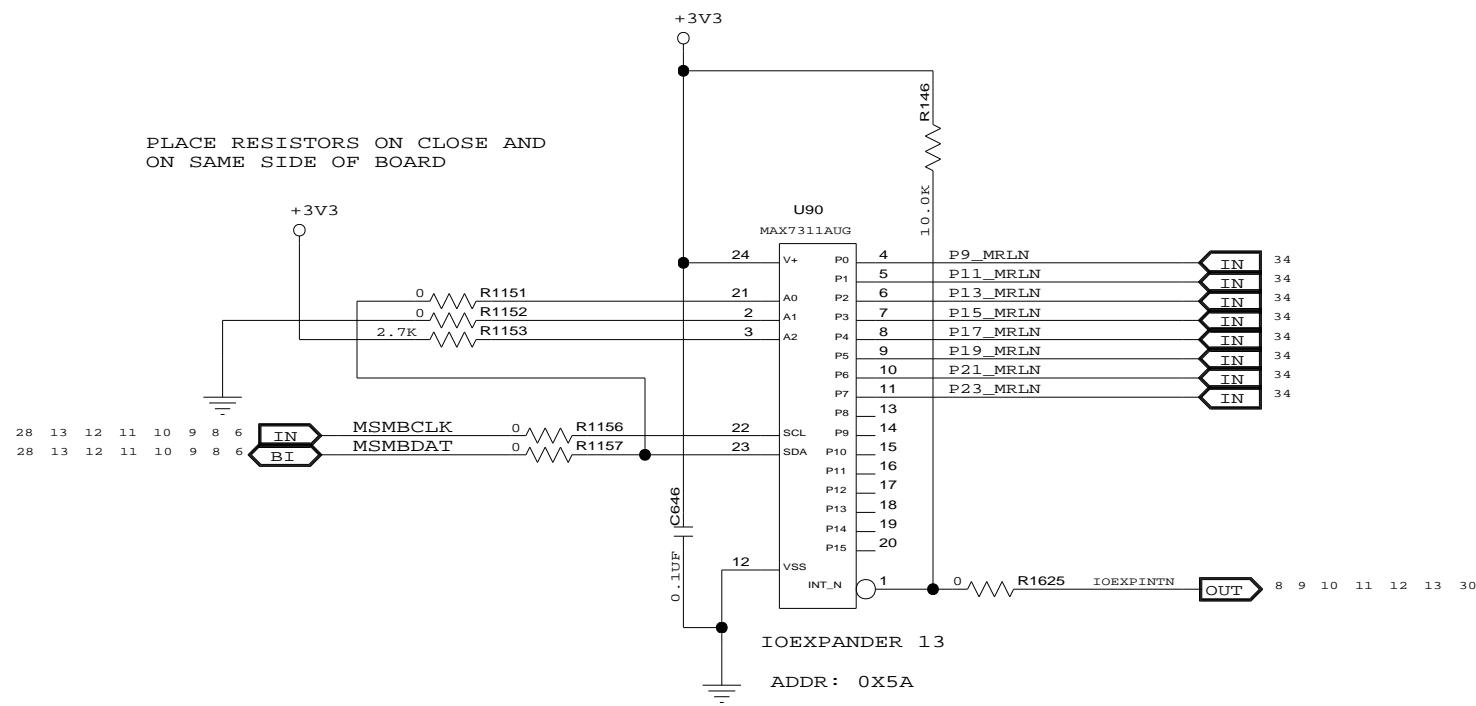
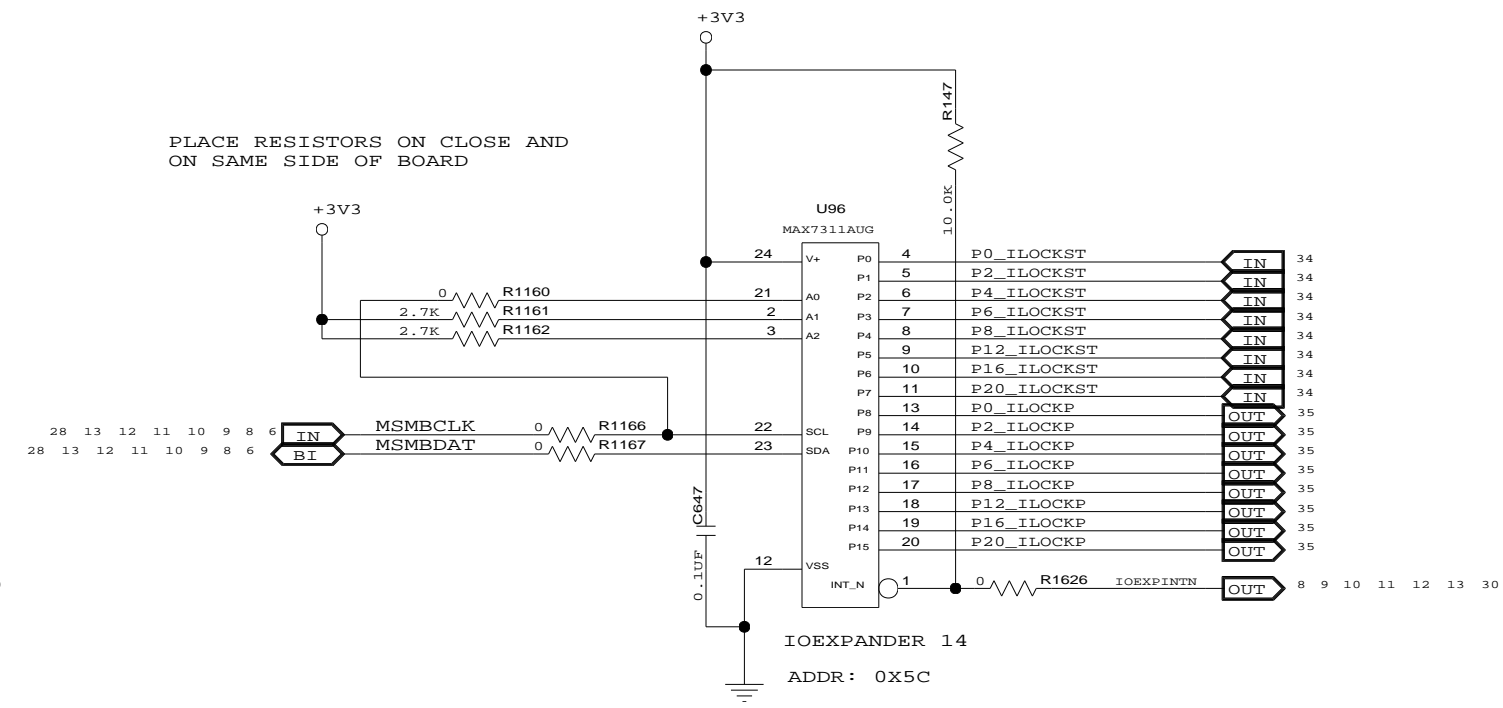
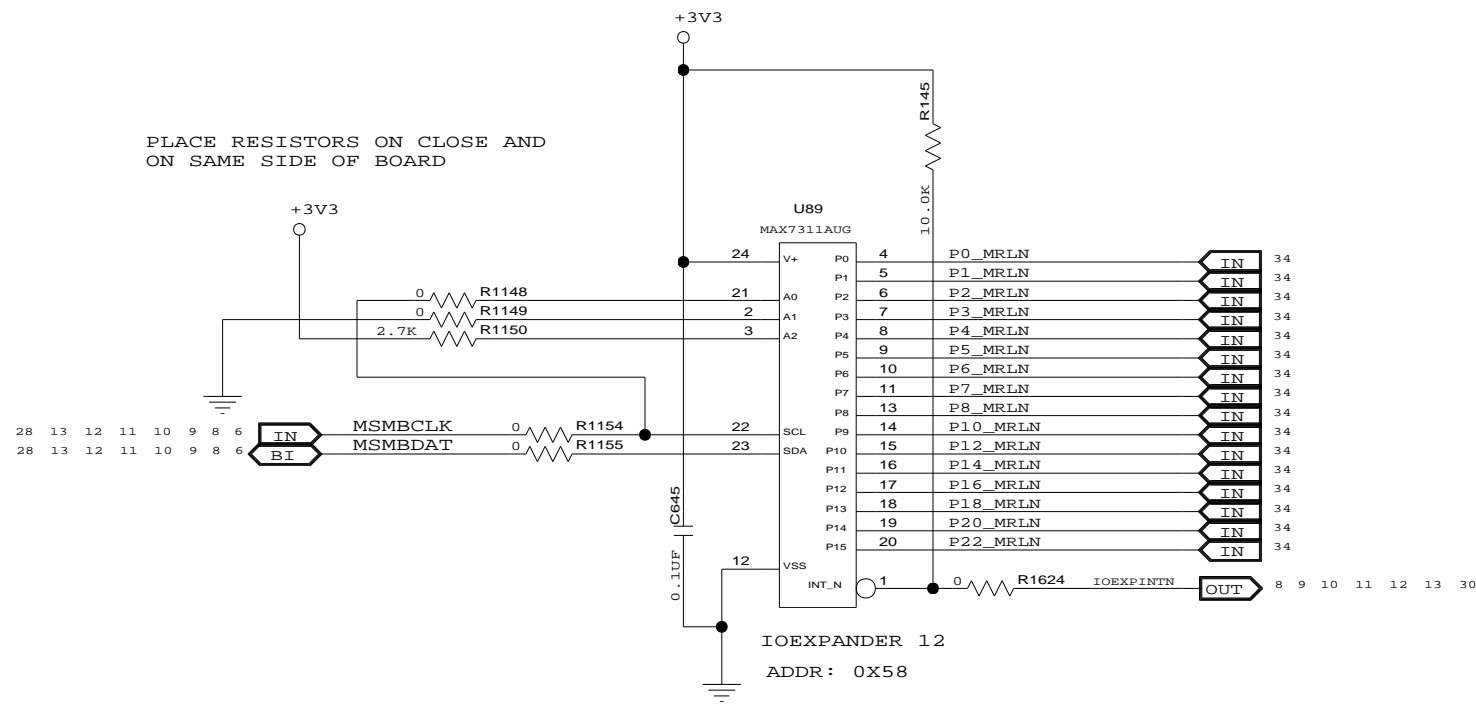

CONFIDENTIAL PROPERTY OF INTEGRATED DEVICE TECHNOLOGY, INC.
6024 SILVER CREEK VALLEY ROAD, SAN JOSE, CA 95138
COPYRIGHT (C) 2010 IDT

TITLE EB-LOGAN-19			
IOEXPANDER 12-15			
SIZE	DRAWING NO.	FAB P/N	REV.
B	SCH-PESEB-002	18-692-001	2.0
AUTHOR		CHECKED BY	
Tony Tran		Derek Huang	
Thu Jun 10 11:24:45 2010			SHEET 11 OF 41

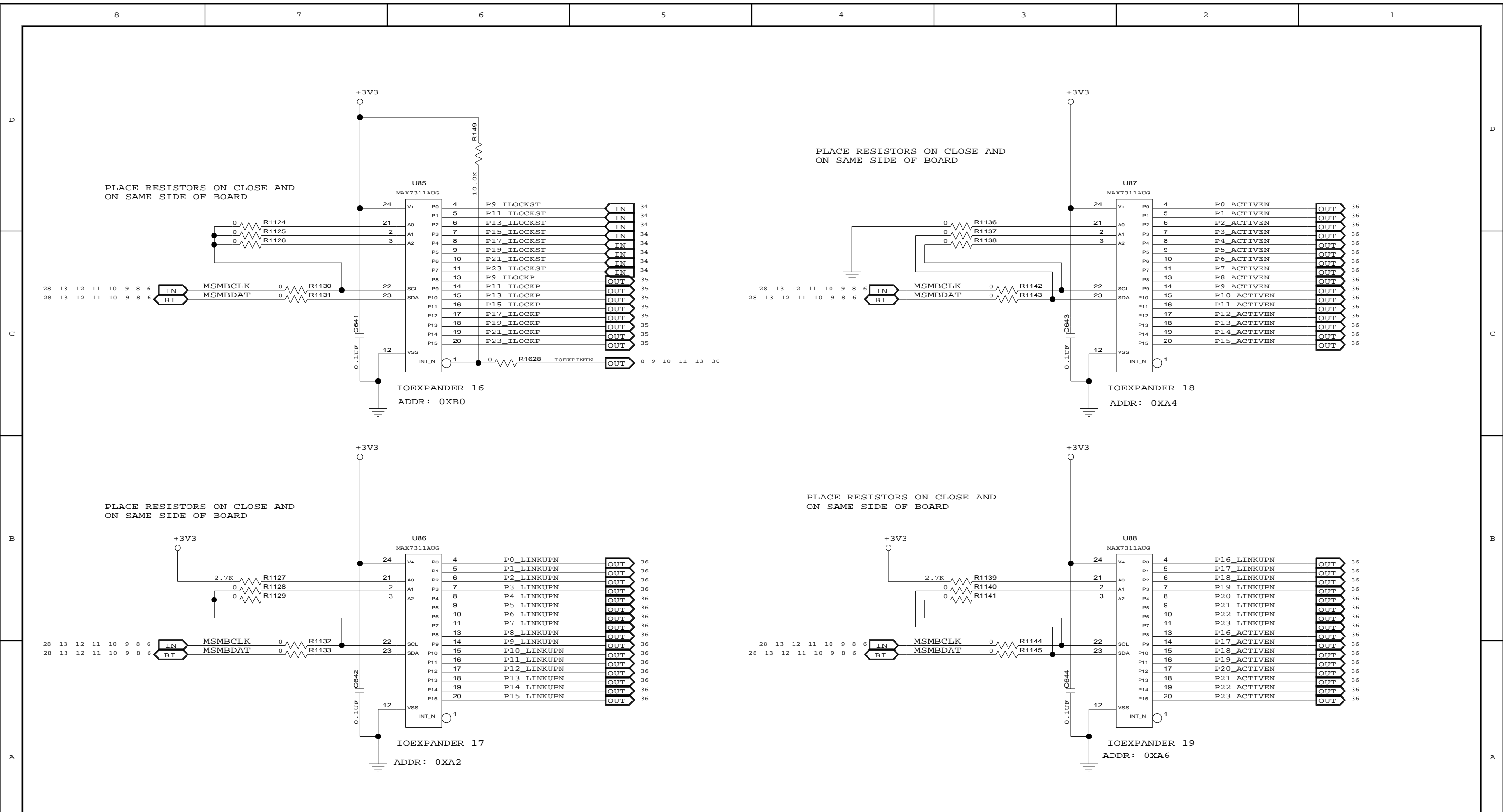

PLACE RESISTORS ON CLOSE AND ON SAME SIDE OF BOARD

PLACE RESISTORS ON CLOSE AND ON SAME SIDE OF BOARD

PLACE RESISTORS ON CLOSE AND ON SAME SIDE OF BOARD

PLACE RESISTORS ON CLOSE AND ON SAME SIDE OF BOARD

TITLE EB-LOGAN-19

IOEXPANDER 16-19

SIZE	DRAWING NO.	FAB P/N	REV.
B	SCH-PESEB-002	18-692-001	2.0
AUTHOR		CHECKED BY	
Tony Tran		Derek Huang	
Thu Jun 10 11:24:46 2010			SHEET 12 OF 41

CONFIDENTIAL PROPERTY OF INTEGRATED DEVICE TECHNOLOGY, INC.
6024 SILVER CREEK VALLEY ROAD, SAN JOSE, CA 95138
COPYRIGHT (C) 2010 IDT

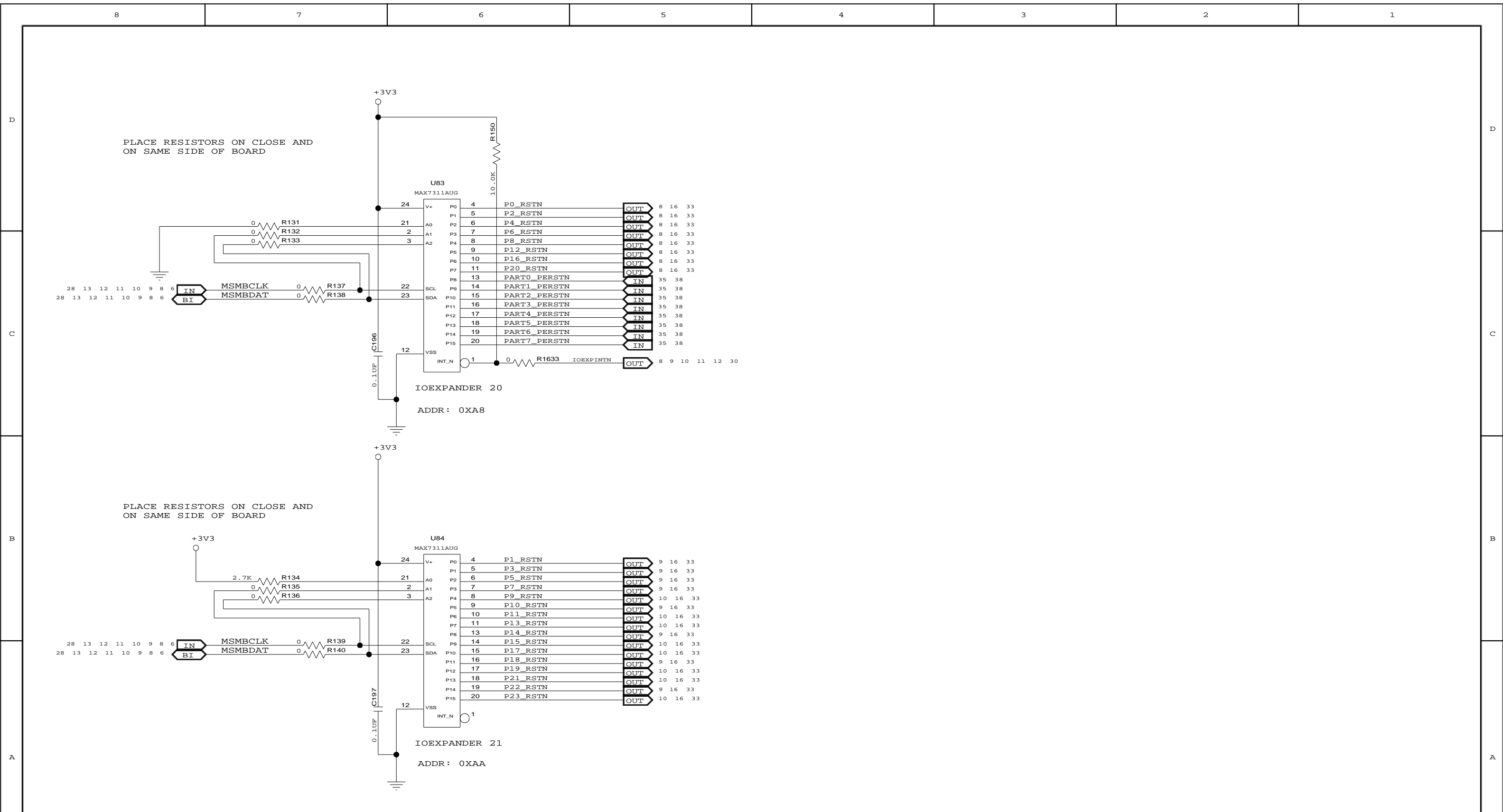



TITLE EB-LOGAN-19

IOEXPANDER 20-21

SIZE	DRAWING NO.	FAB P/N	REV.
B	SCH-PESEB-002	18-692-001	2.0
AUTHOR		CHECKED BY	
Tony Tran		Derek Huang	
Thu Jun 10 11:24:46 2010			SHEET 13 OF 41

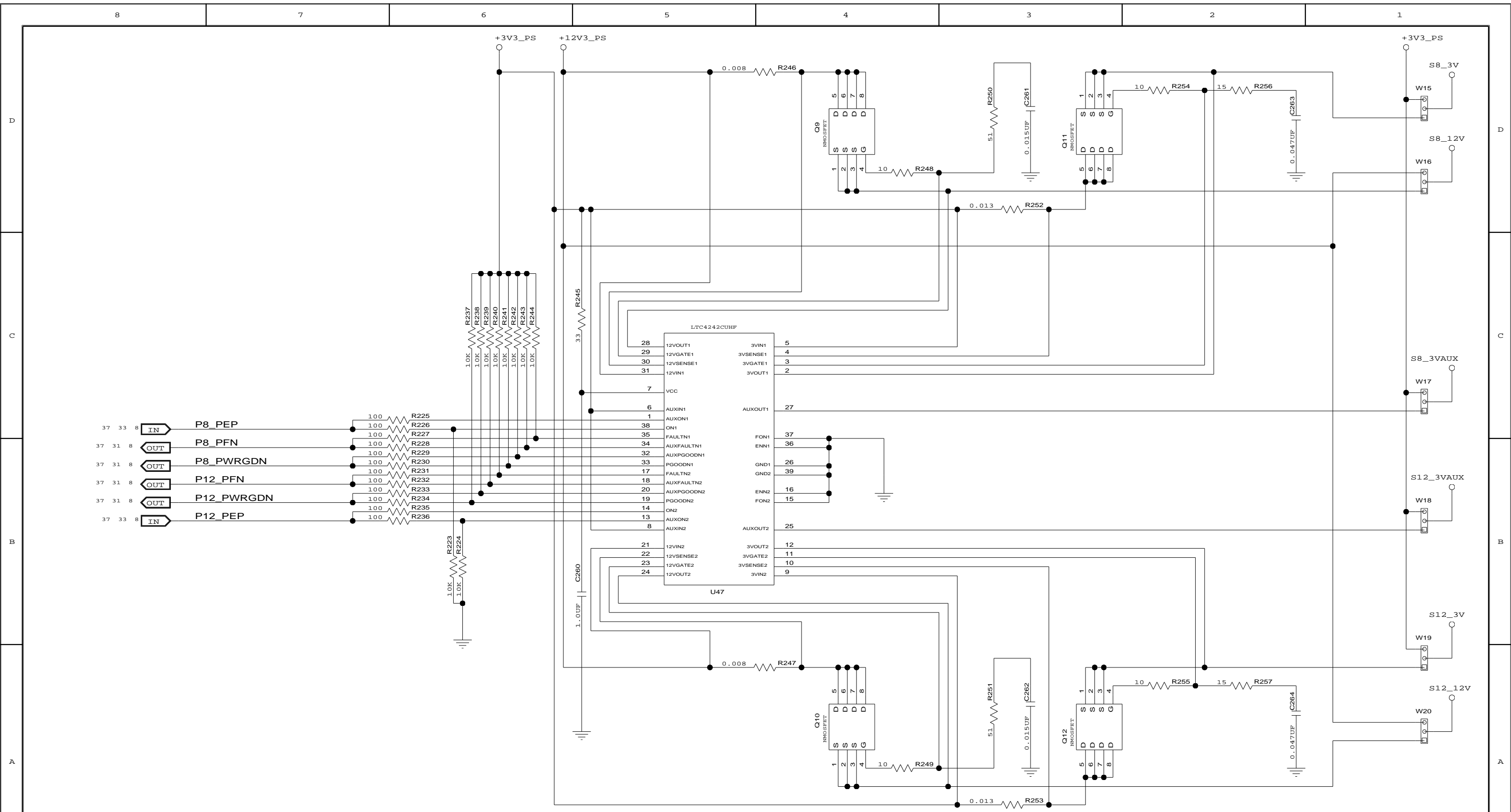
CONFIDENTIAL PROPERTY OF INTEGRATED DEVICE TECHNOLOGY, INC.
 6024 SILVER CREEK VALLEY ROAD. SAN JOSE, CA 95138
 COPYRIGHT (C) 2010 IDT

CONFIDENTIAL PROPERTY OF INTEGRATED DEVICE TECHNOLOGY, INC.
6024 SILVER CREEK VALLEY ROAD. SAN JOSE, CA 95138
COPYRIGHT (C) 2010 IDT

TITLE EB-LOGAN-19			
HOT PLUG CONTROL PORTS 8-12			
SIZE	DRAWING NO.	FAB P/N	REV.
B	SCH-PESEB-002	18-692-001	2.0
AUTHOR		CHECKED BY	
Tony Tran		Derek Huang	
Thu Jun 10 11:24:46 2010			SHEET 14 OF 41



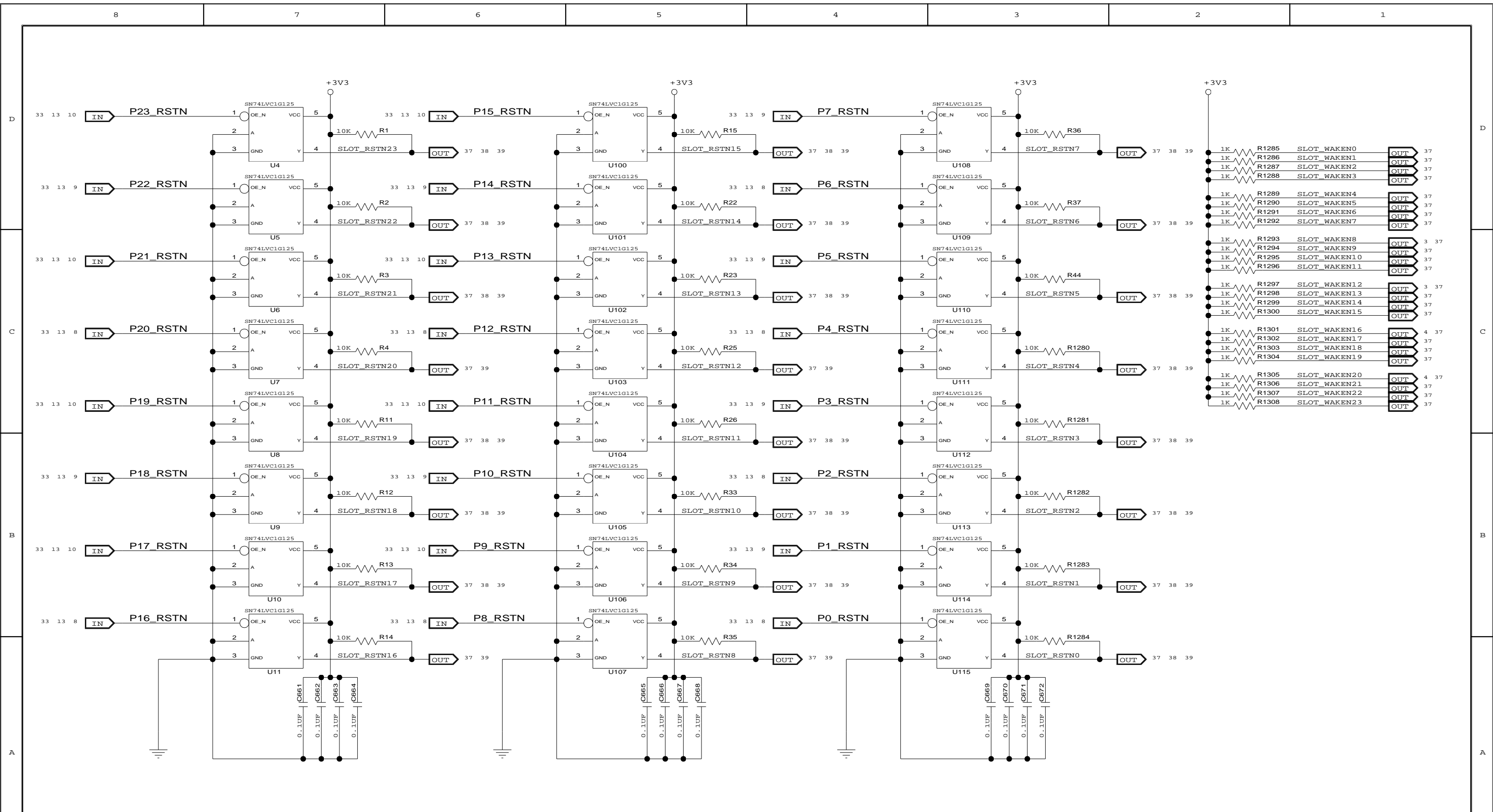



CONFIDENTIAL PROPERTY OF INTEGRATED DEVICE TECHNOLOGY, INC.
6024 SILVER CREEK VALLEY ROAD, SAN JOSE, CA 95138
COPYRIGHT (C) 2010 IDT

TITLE EB-LOGAN-19

SLOT RESETS AND WAKE PULL-UPS

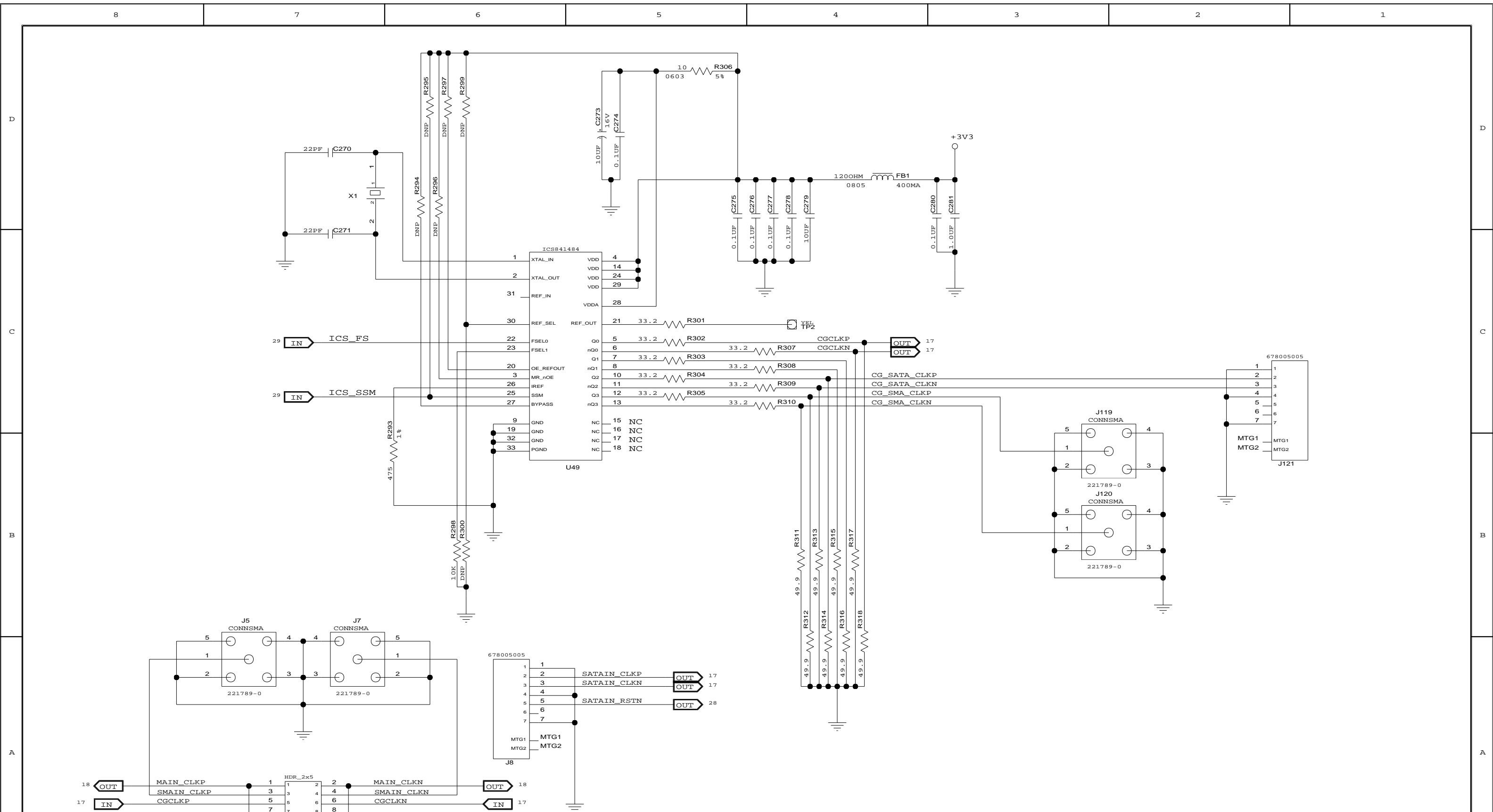
SIZE	DRAWING NO.	FAB P/N	REV.
B	SCH-PESEB-002	18-692-001	2.0
AUTHOR		CHECKED BY	
Tony Tran		Derek Huang	
Thu Jun 10 11:24:47 2010			SHEET 16 OF 41



		TITLE EB-LOGAN-19	
		CLOCK	
SIZE B	DRAWING NO. SCH-PESEB-002	FAB P/N 18-692-001	REV. 2.0
AUTHOR Tony Tran		CHECKED BY Derek Huang	
CONFIDENTIAL PROPERTY OF INTEGRATED DEVICE TECHNOLOGY, INC. 6024 SILVER CREEK VALLEY ROAD, SAN JOSE, CA 95138 COPYRIGHT (C) 2010 IDT		Thu Jun 10 11:24:48 2010	
		SHEET 17 OF 41	

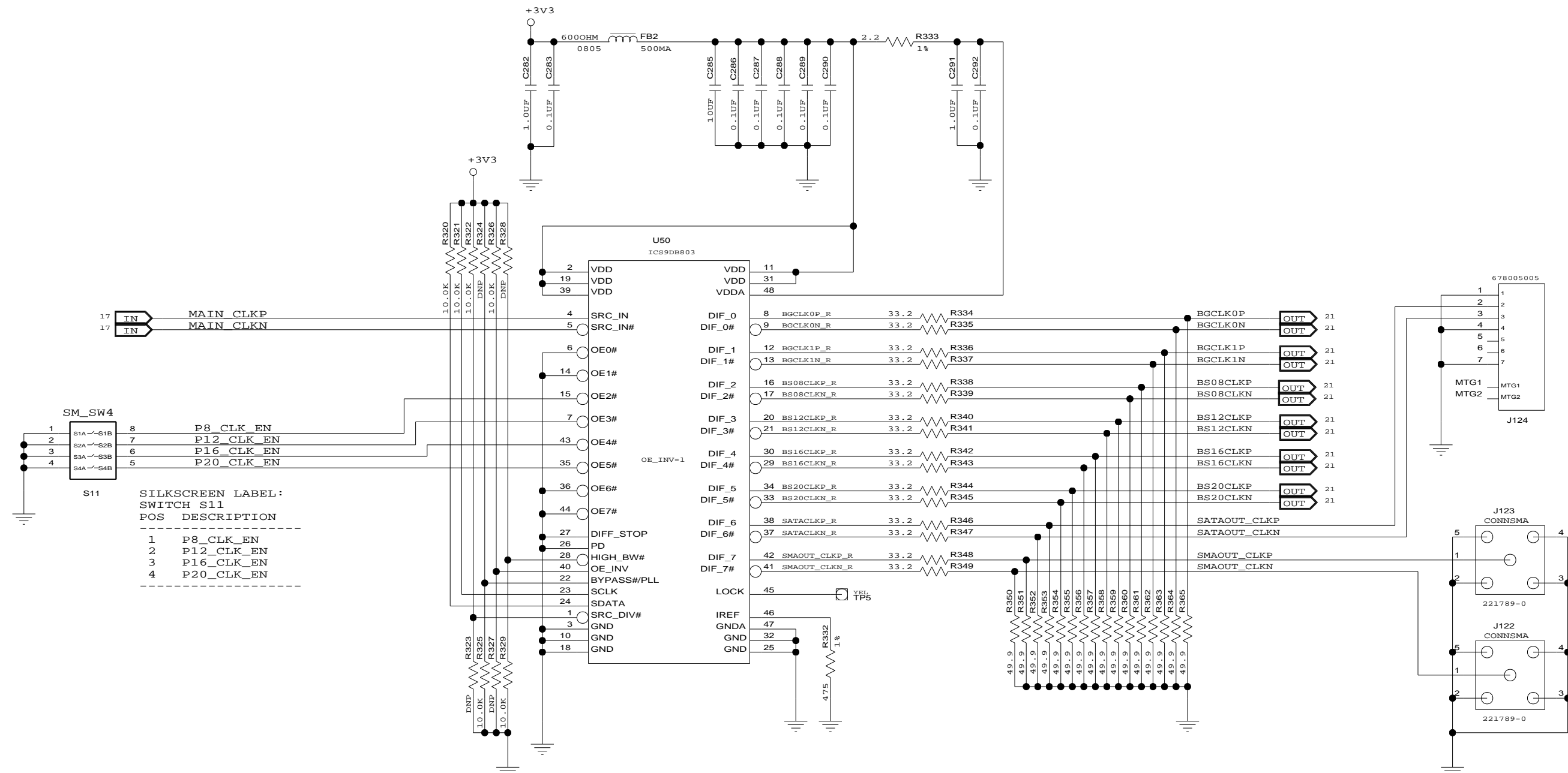

SILKSCREEN LABEL:
SWITCH S11
POS DESCRIPTION

POS	DESCRIPTION
1	P8_CLK_EN
2	P12_CLK_EN
3	P16_CLK_EN
4	P20_CLK_EN



CONFIDENTIAL PROPERTY OF INTEGRATED DEVICE TECHNOLOGY, INC.
6024 SILVER CREEK VALLEY ROAD, SAN JOSE, CA 95138
COPYRIGHT (C) 2010 IDT

TITLE EB-LOGAN-19

CLOCK BUFFER

SIZE	DRAWING NO.	FAB P/N	REV.
B	SCH-PESEB-002	18-692-001	2.0
AUTHOR		CHECKED BY	
Tony Tran		Derek Huang	
Thu Jun 10 11:24:48 2010			SHEET 18 OF 41

P8CLK - DUT PORT 8 CLK
 LP8CLK - LOCAL CLOCK GEN. PORT 8 CLK
 P8SHXCLK - TO SLOT CLK HEADERS

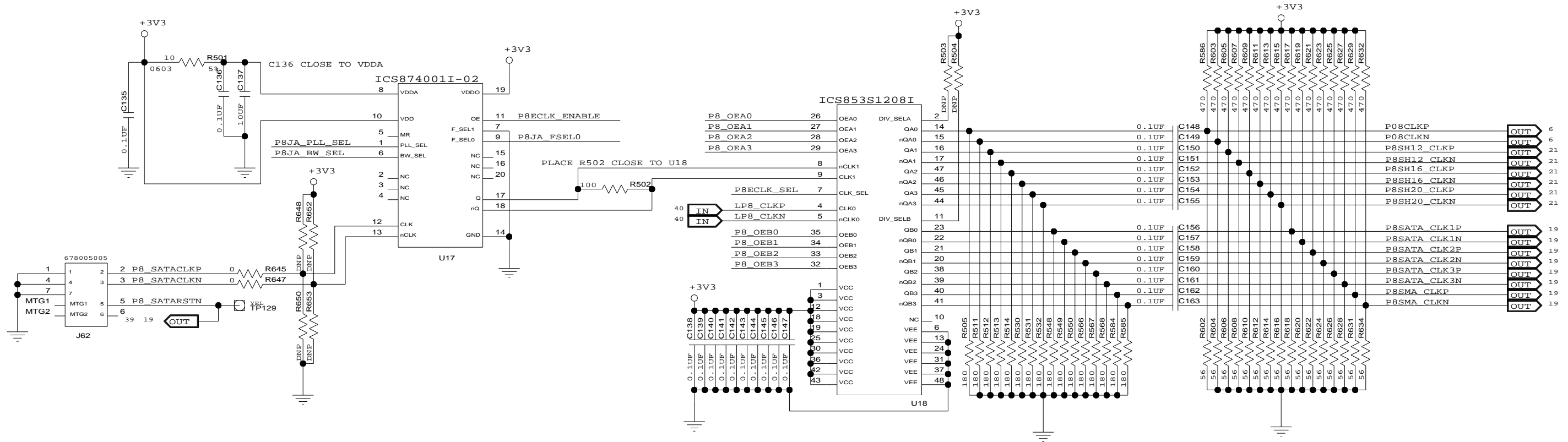

DEFAULT DIPSW SETTING

- S19:1 OFF (SATACLK)
- S19:3 OFF (PLL)
- S19:4 OFF (2.2MHZ)
- S19:5 OFF (U15 OUT ON)
- S19:6 ON (100MHZ)

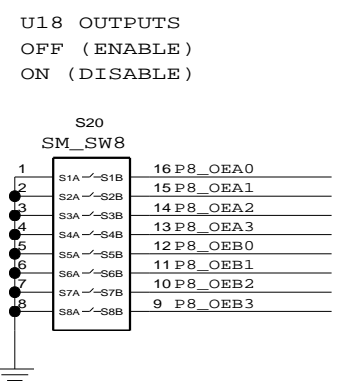
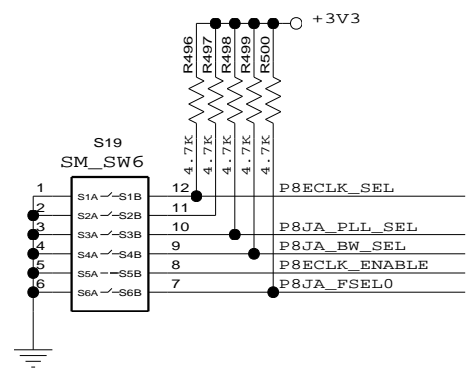
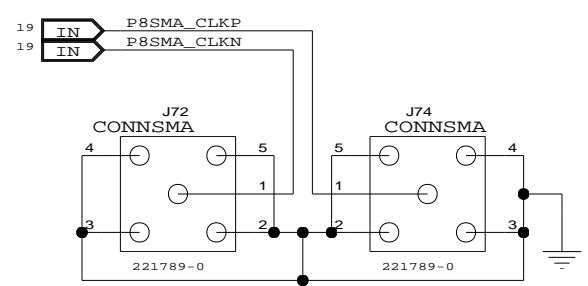
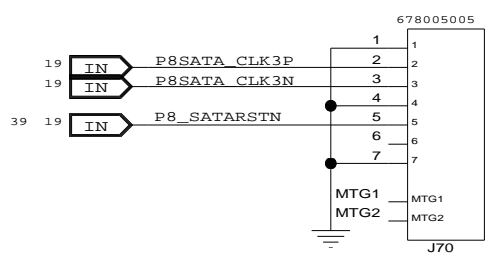
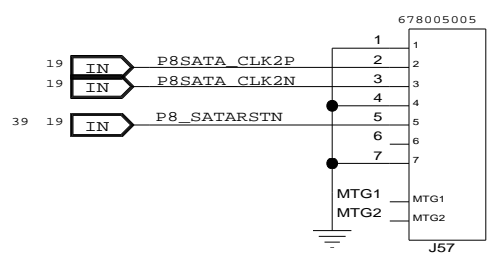
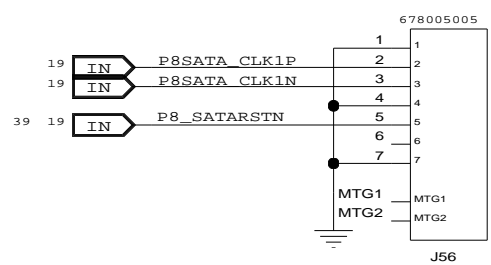

IDT
 CONFIDENTIAL PROPERTY OF INTEGRATED DEVICE TECHNOLOGY, INC.
 6024 SILVER CREEK VALLEY ROAD, SAN JOSE, CA 95138
 COPYRIGHT (C) 2010 IDT

TITLE EB-LOGAN-19			
CLOCK SELECTOR DUT PCLK 8			
SIZE	DRAWING NO.	FAB P/N	REV.
B	SCH-PESEB-002	18-692-001	2.0
AUTHOR		CHECKED BY	
Tony Tran		Derek Huang	
Thu Jun 10 11:28:22 2010			SHEET 19 OF 41

P16CLK - DUT PORT 16 CLK
 LP16CLK - LOCAL CLOCK GEN. PORT 16 CLK
 P16SHXCLK - TO SLOT CLK HEADERS

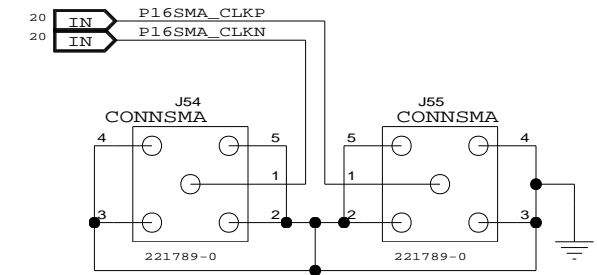
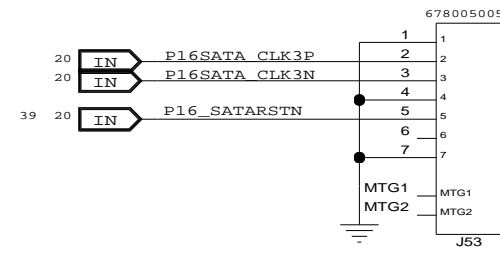
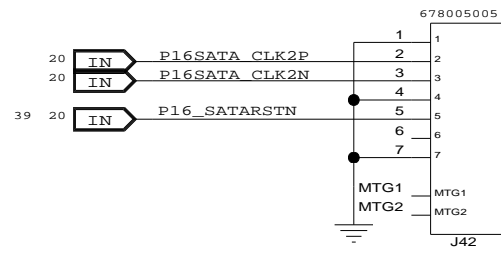
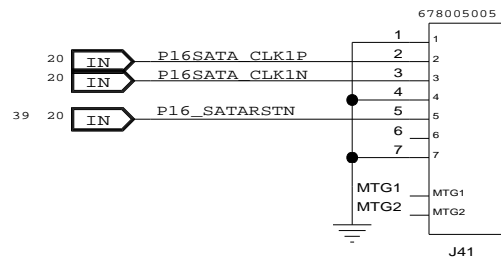
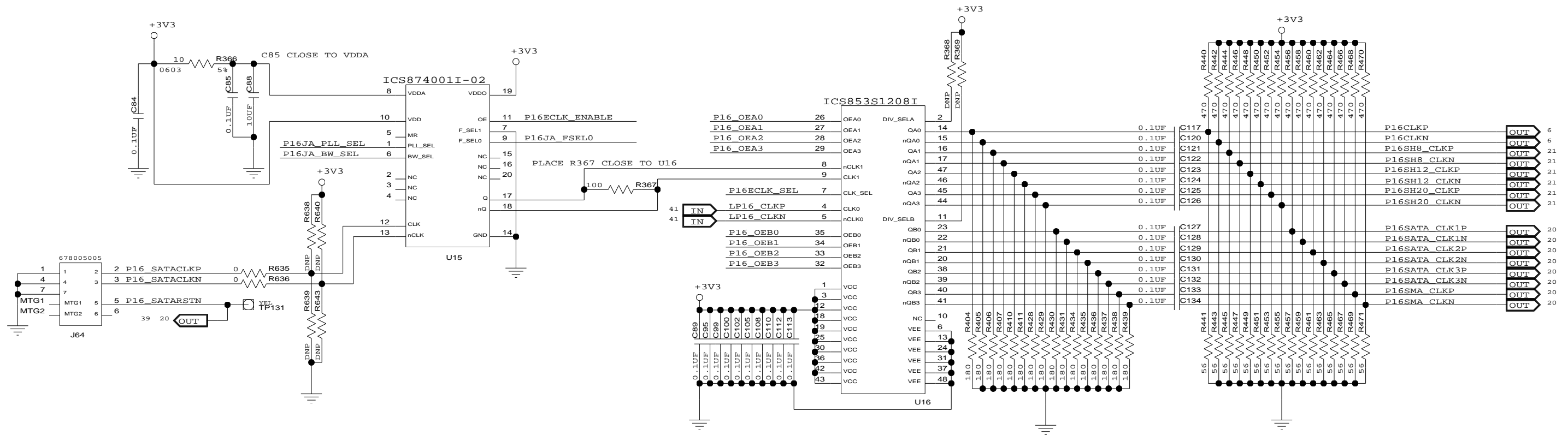

DEFAULT DIPSW SETTING

- S17:1 OFF (SATACLK)
- S17:3 OFF (PLL)
- S17:4 OFF (2.2MHZ)
- S17:5 OFF (U15 OUT ON)
- S17:6 ON (100MHZ)

U16 OUTPUTS
 OFF (ENABLE)
 ON (DISABLE)

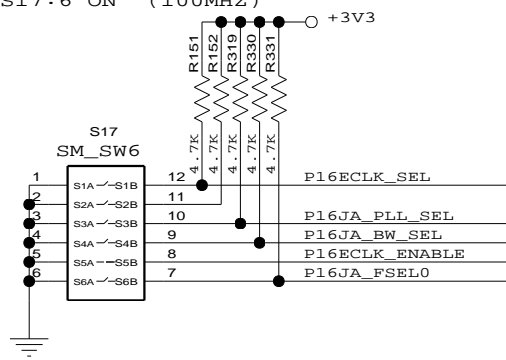
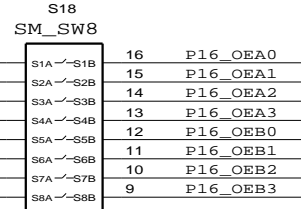

CONFIDENTIAL PROPERTY OF INTEGRATED DEVICE TECHNOLOGY, INC.
 6024 SILVER CREEK VALLEY ROAD. SAN JOSE, CA 95138
 COPYRIGHT (C) 2010 IDT

TITLE EB-LOGAN-19			
CLOCK SELECTOR DUT PCLK 16			
SIZE	DRAWING NO.	FAB P/N	REV.
B	SCH-PESEB-002	18-692-001	2.0
AUTHOR		CHECKED BY	
Tony Tran		Derek Huang	
Thu Jun 10 11:28:19 2010			SHEET 20 OF 41

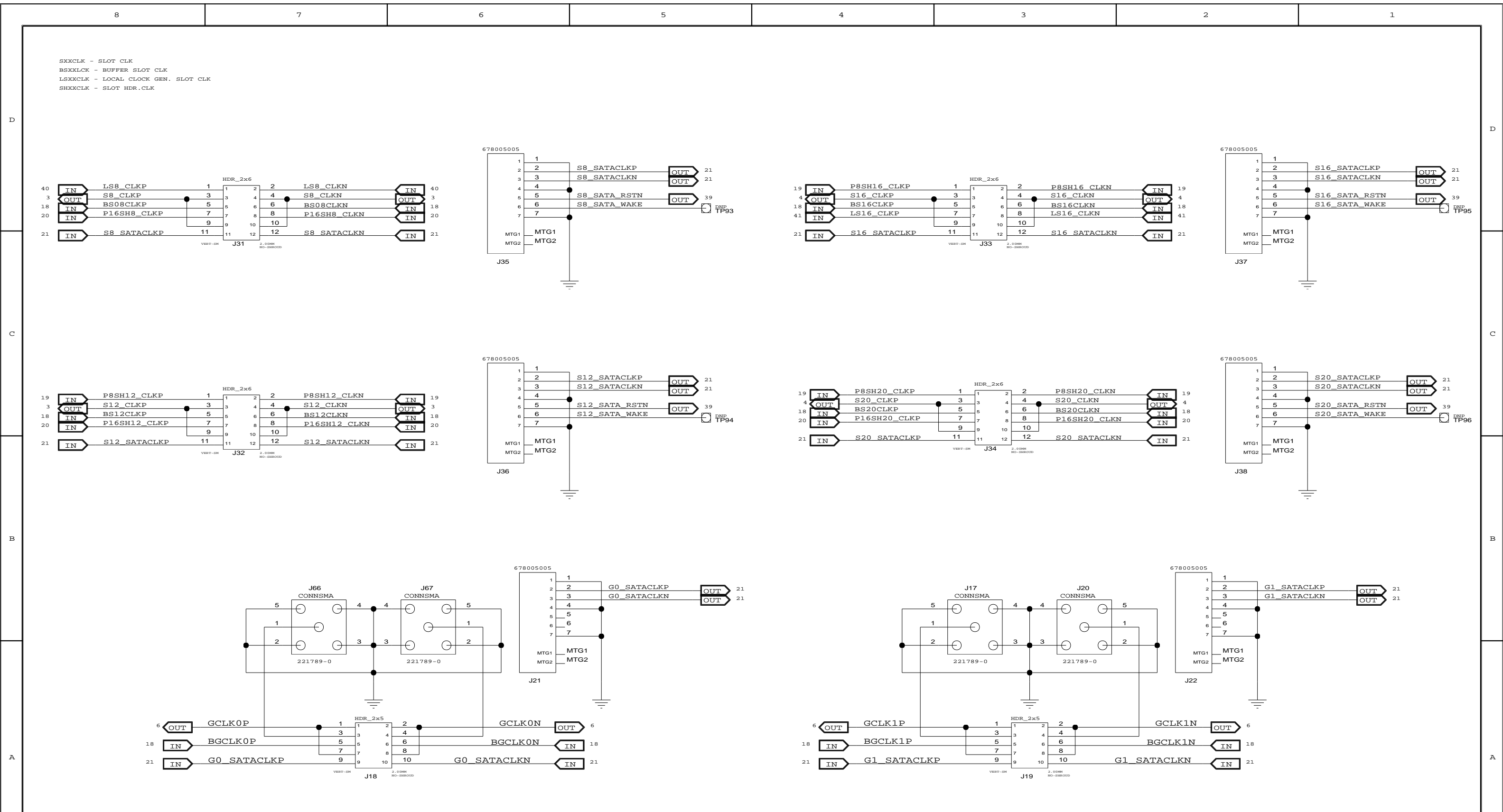

SXXCLK - SLOT CLK
 BSXXCLK - BUFFER SLOT CLK
 LSXXCLK - LOCAL CLOCK GEN. SLOT CLK
 SHXXCLK - SLOT HDR.CLK

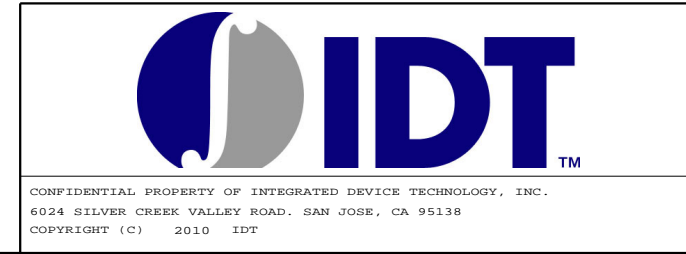

TITLE EB-LOGAN-19			
CLOCK SELECTOR SLOTS 8-20, GCLK			
SIZE	DRAWING NO.	FAB P/N	REV.
B	SCH-PESEB-002	18-692-001	2.0
AUTHOR		CHECKED BY	
Tony Tran		Derek Huang	
Thu Jun 10 11:24:49 2010			SHEET 21 OF 41

MINIMUM POWER SUPPLY LOADS

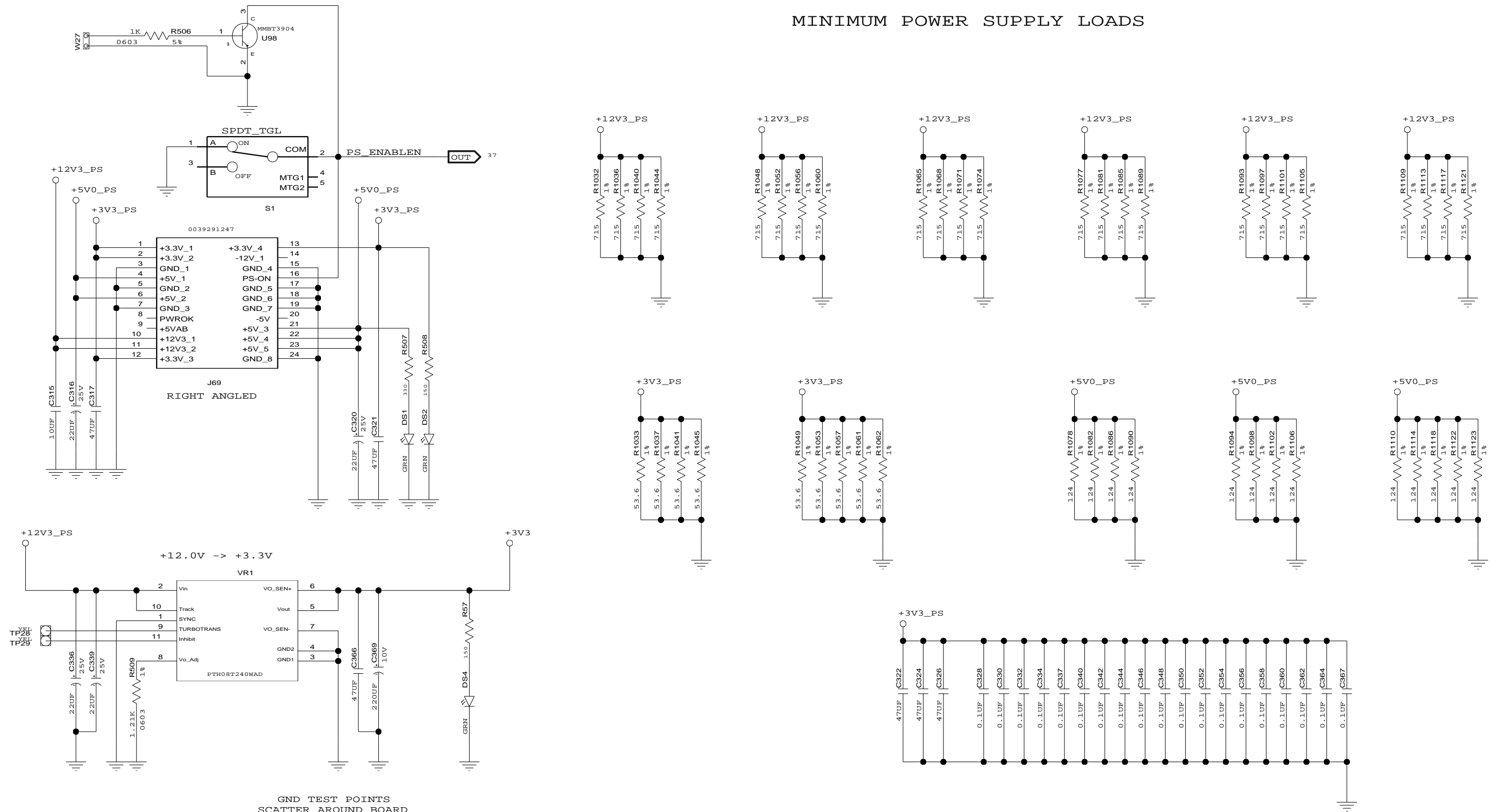

GND TEST POINTS
SCATTER AROUND BOARD

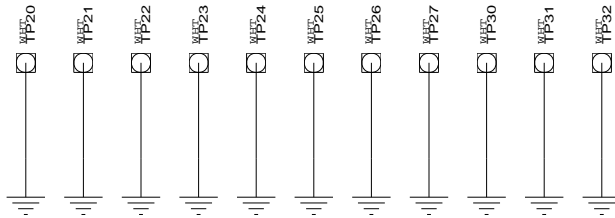
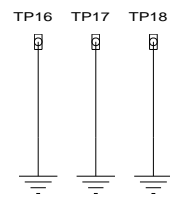

CONFIDENTIAL PROPERTY OF INTEGRATED DEVICE TECHNOLOGY, INC.
6024 SILVER CREEK VALLEY ROAD. SAN JOSE, CA 95138
COPYRIGHT (C) 2010 IDT

TITLE EB-LOGAN-19			
POWER CONNECTORS, MIN LOAD RESISTORS			
SIZE B	DRAWING NO. SCH-PESEB-002	FAB P/N 18-692-001	REV. 2.0
AUTHOR Tony Tran		CHECKED BY Derek Huang	
Thu Jun 10 11:24:50 2010			SHEET 22 OF 41

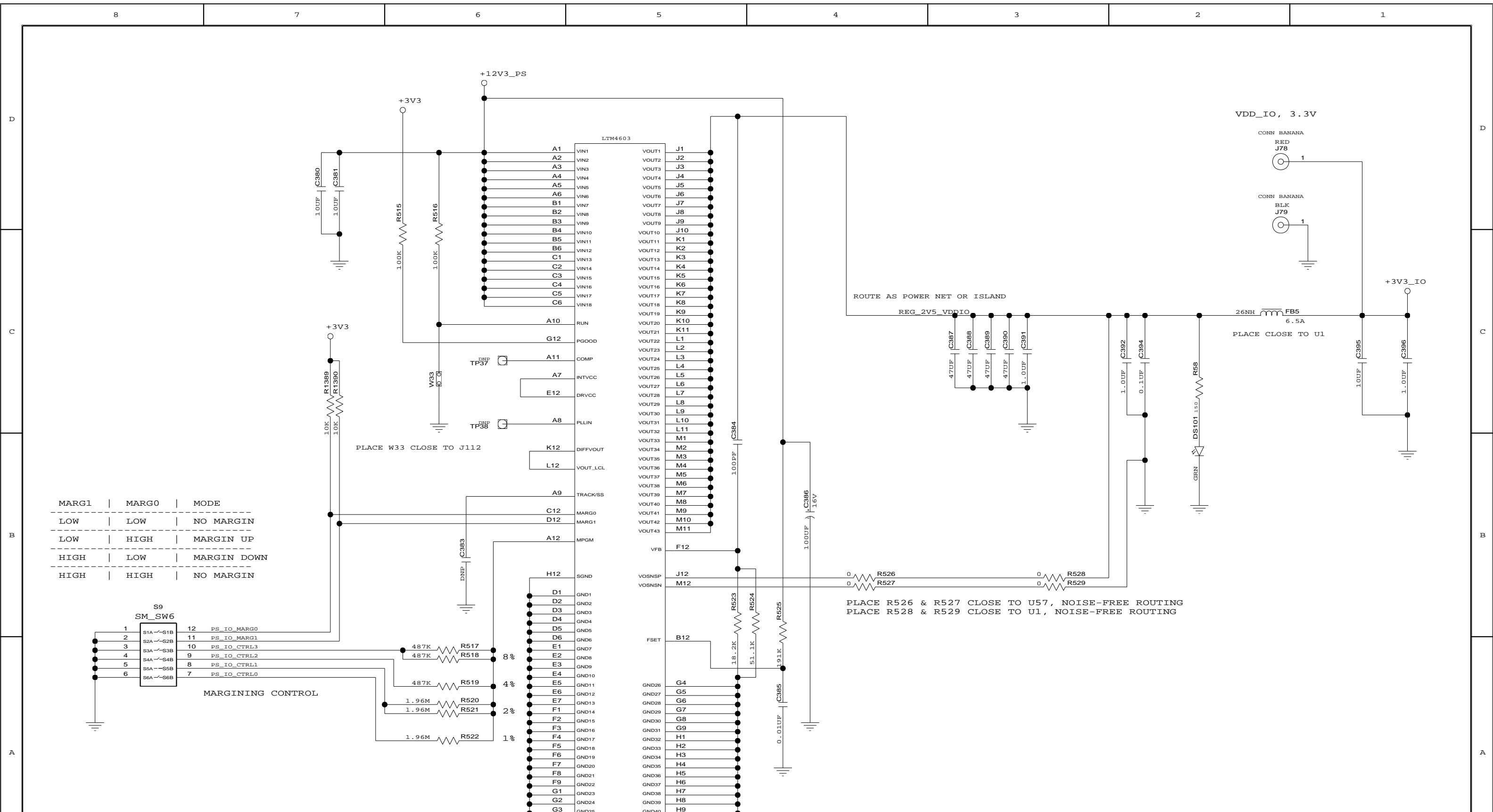

MARG1	MARG0	MODE
LOW	LOW	NO MARGIN
LOW	HIGH	MARGIN UP
HIGH	LOW	MARGIN DOWN
HIGH	HIGH	NO MARGIN

MARGINING CONTROL

PLACE R526 & R527 CLOSE TO U57, NOISE-FREE ROUTING
 PLACE R528 & R529 CLOSE TO U1, NOISE-FREE ROUTING

TITLE EB-LOGAN-19

POWER REGULATOR - VDDIO

SIZE	DRAWING NO.	FAB P/N	REV.
B	SCH-PESEB-002	18-692-001	2.0
AUTHOR		CHECKED BY	
Tony Tran		Derek Huang	
Thu Jun 10 11:24:50 2010			SHEET 23 OF 41

CONFIDENTIAL PROPERTY OF INTEGRATED DEVICE TECHNOLOGY, INC.
 6024 SILVER CREEK VALLEY ROAD, SAN JOSE, CA 95138
 COPYRIGHT (C) 2010 IDT

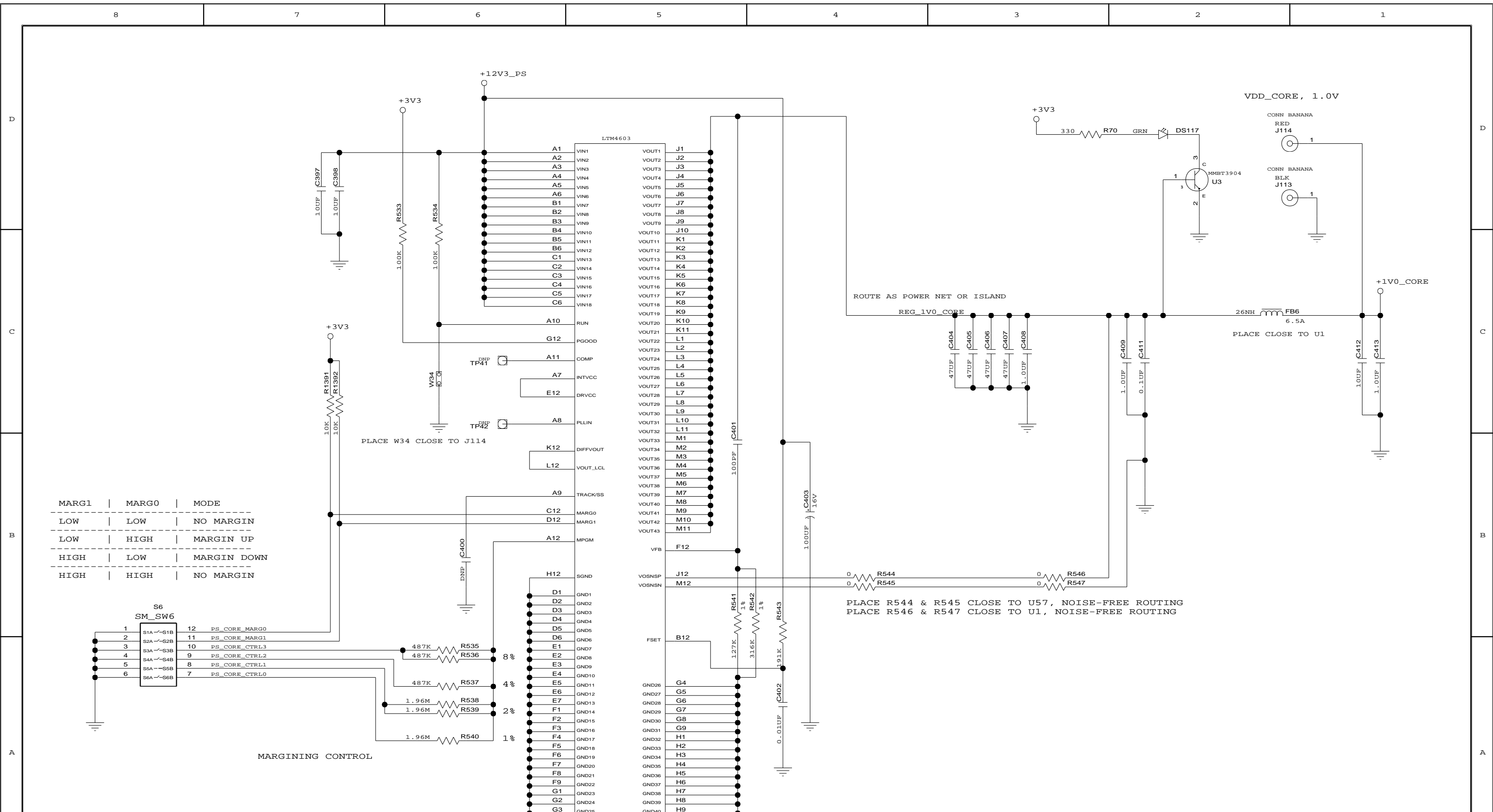



CONFIDENTIAL PROPERTY OF INTEGRATED DEVICE TECHNOLOGY, INC.
6024 SILVER CREEK VALLEY ROAD, SAN JOSE, CA 95138
COPYRIGHT (C) 2010 IDT

TITLE EB-LOGAN-19

POWER REGULATOR - VDDCORE

SIZE	DRAWING NO.	FAB P/N	REV.
B	SCH-PESEB-002	18-692-001	2.0
AUTHOR		CHECKED BY	
Tony Tran		Derek Huang	
Thu Jun 10 11:24:51 2010			SHEET 24 OF 41

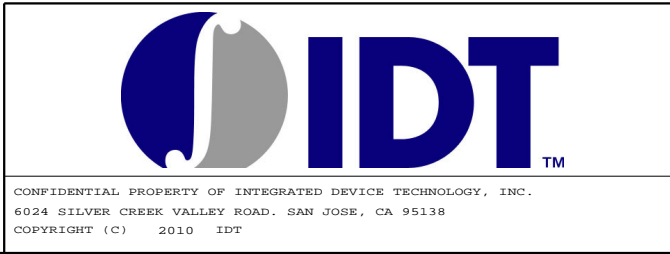
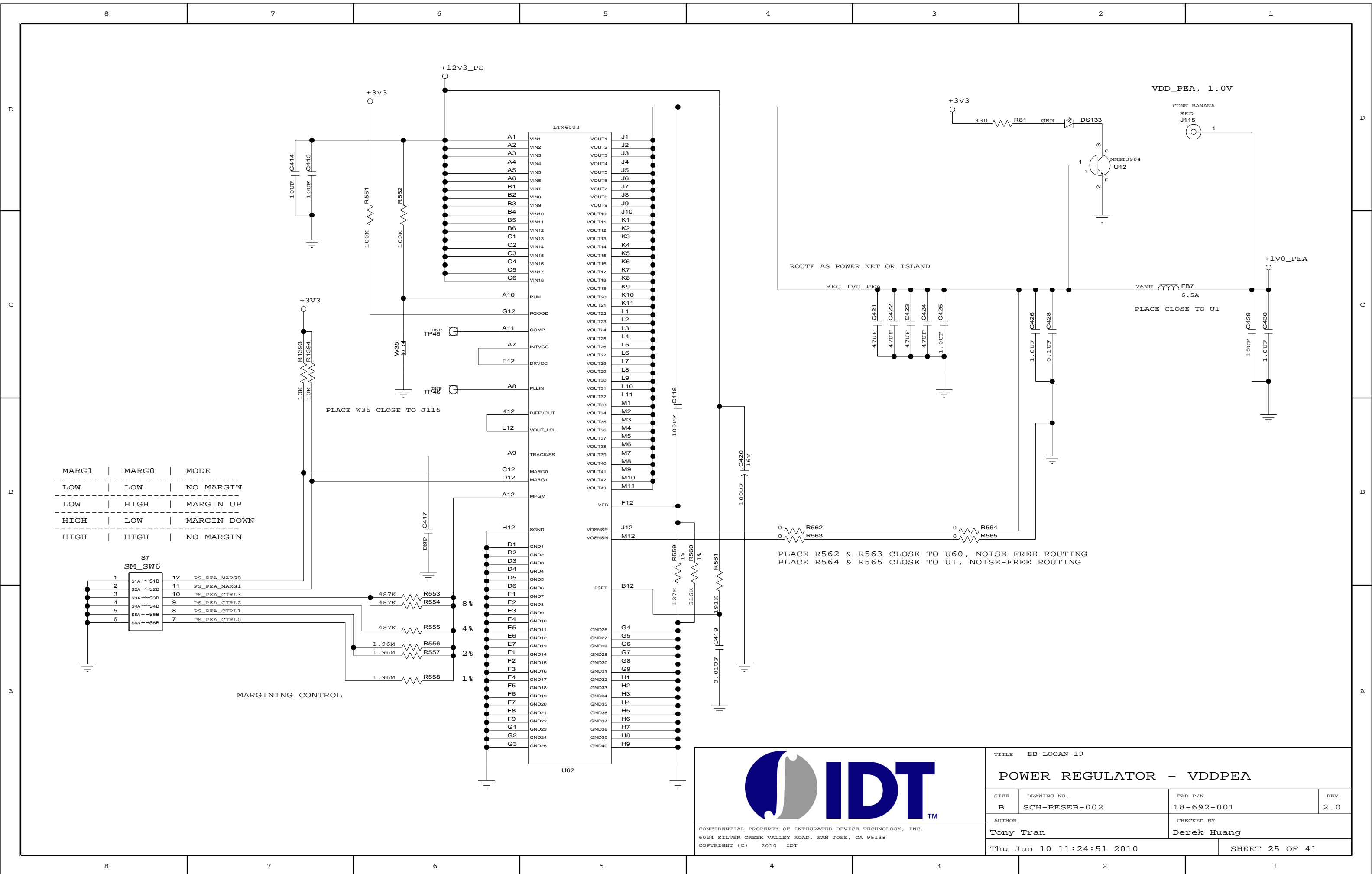

TITLE EB-LOGAN-19			
POWER REGULATOR - VDDPEA			
SIZE	DRAWING NO.	FAB P/N	REV.
B	SCH-PESEB-002	18-692-001	2.0
AUTHOR		CHECKED BY	
Tony Tran		Derek Huang	
Thu Jun 10 11:24:51 2010			SHEET 25 OF 41

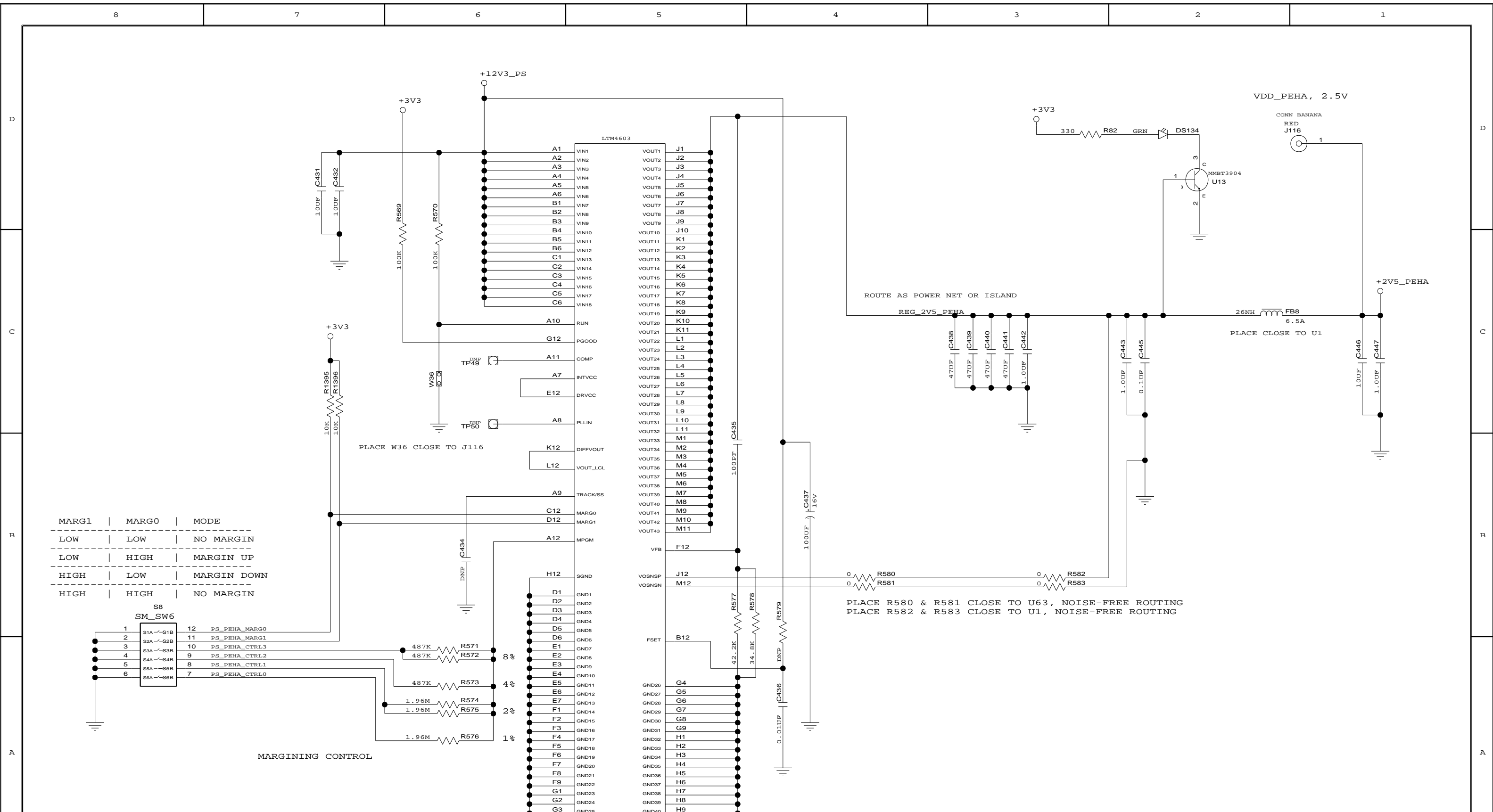

CONFIDENTIAL PROPERTY OF INTEGRATED DEVICE TECHNOLOGY, INC.
6024 SILVER CREEK VALLEY ROAD. SAN JOSE, CA 95138
COPYRIGHT (C) 2010 IDT

TITLE EB-LOGAN-19			
POWER REGULATOR - VDDPEHA			
SIZE	DRAWING NO.	FAB P/N	REV.
B	SCH-PESEB-002	18-692-001	2.0
AUTHOR		CHECKED BY	
Tony Tran		Derek Huang	
Thu Jun 10 11:24:51 2010			SHEET 26 OF 41

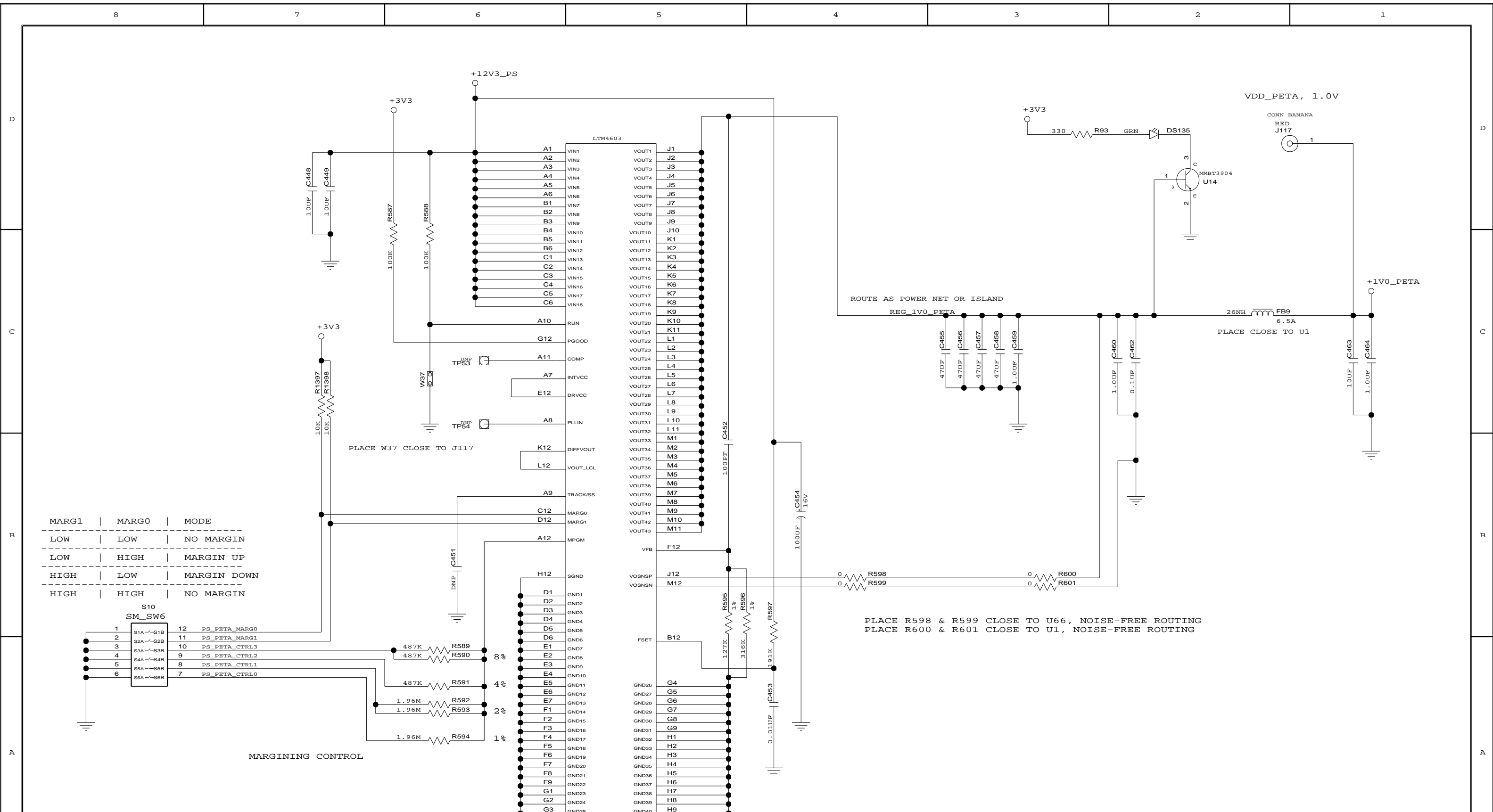

MARG1	MARG0	MODE
LOW	LOW	NO MARGIN
LOW	HIGH	MARGIN UP
HIGH	LOW	MARGIN DOWN
HIGH	HIGH	NO MARGIN

MARGINING CONTROL



TITLE EB-LOGAN-19

POWER REGULATOR - VDDPETA

SIZE	DRAWING NO.	FAB P/N	REV.
B	SCH-PESEB-002	18-692-001	2.0
AUTHOR		CHECKED BY	
Tony Tran		Derek Huang	
Thu Jun 10 11:24:52 2010			SHEET 27 OF 41

CONFIDENTIAL PROPERTY OF INTEGRATED DEVICE TECHNOLOGY, INC.
6024 SILVER CREEK VALLEY ROAD. SAN JOSE, CA 95138
COPYRIGHT (C) 2010 IDT

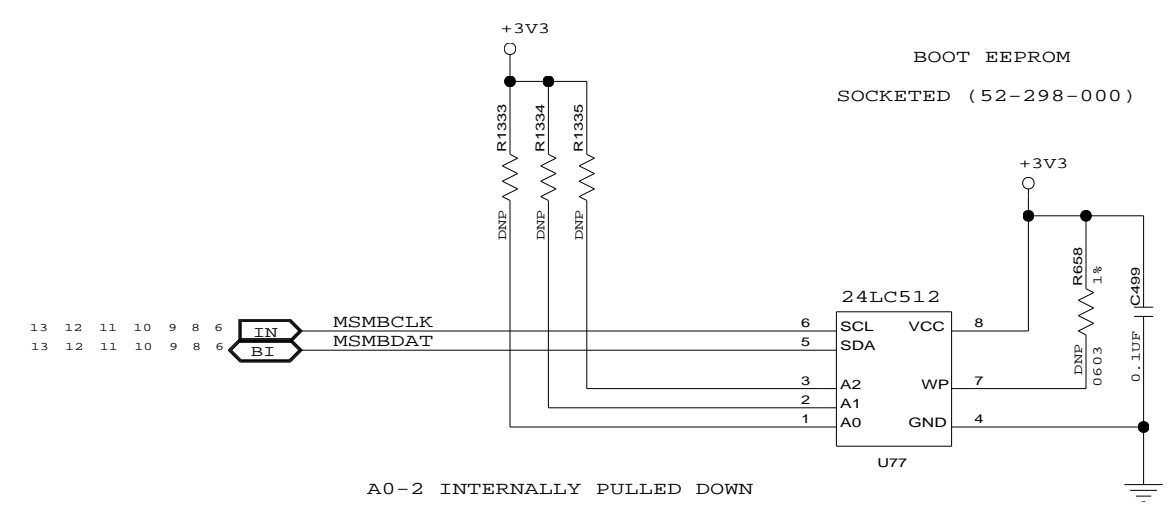
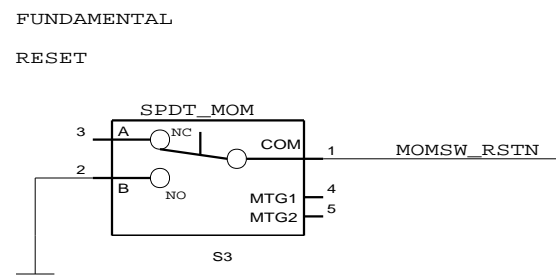
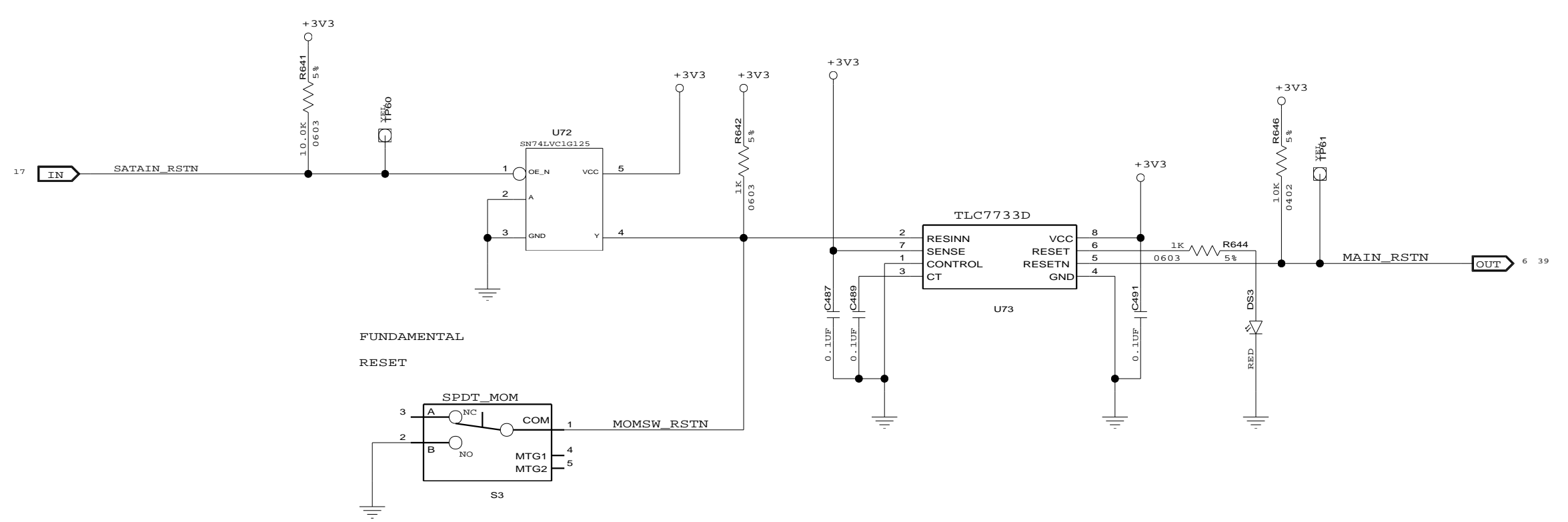

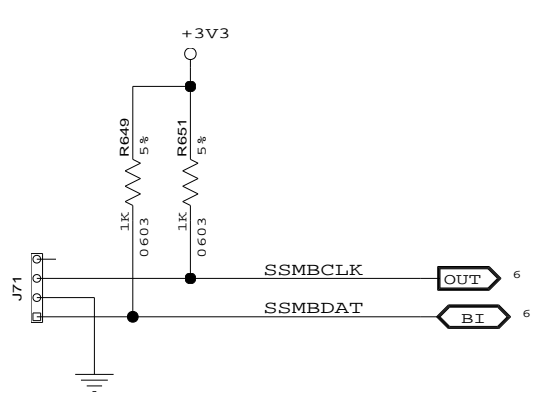
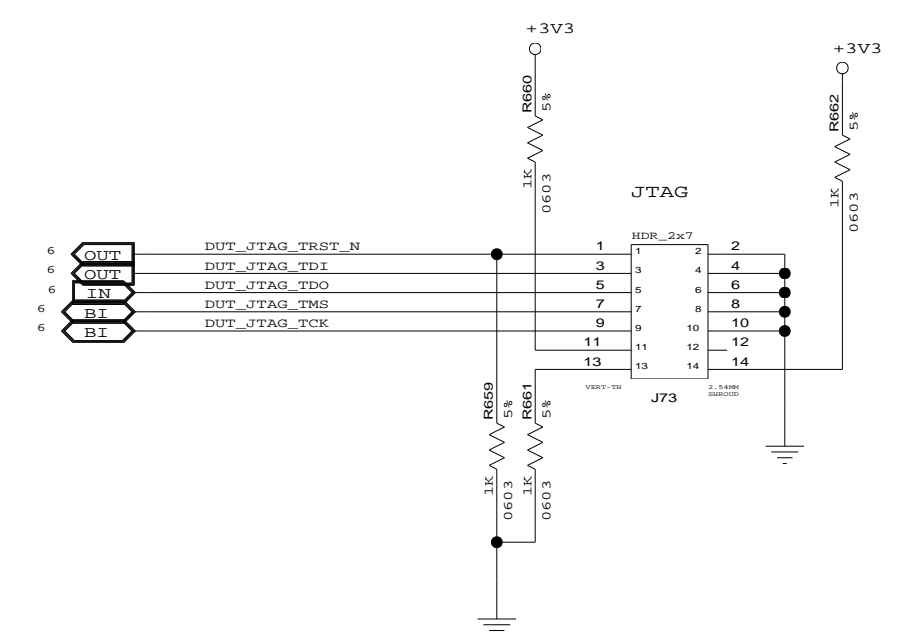

A0-2 INTERNALLY PULLED DOWN

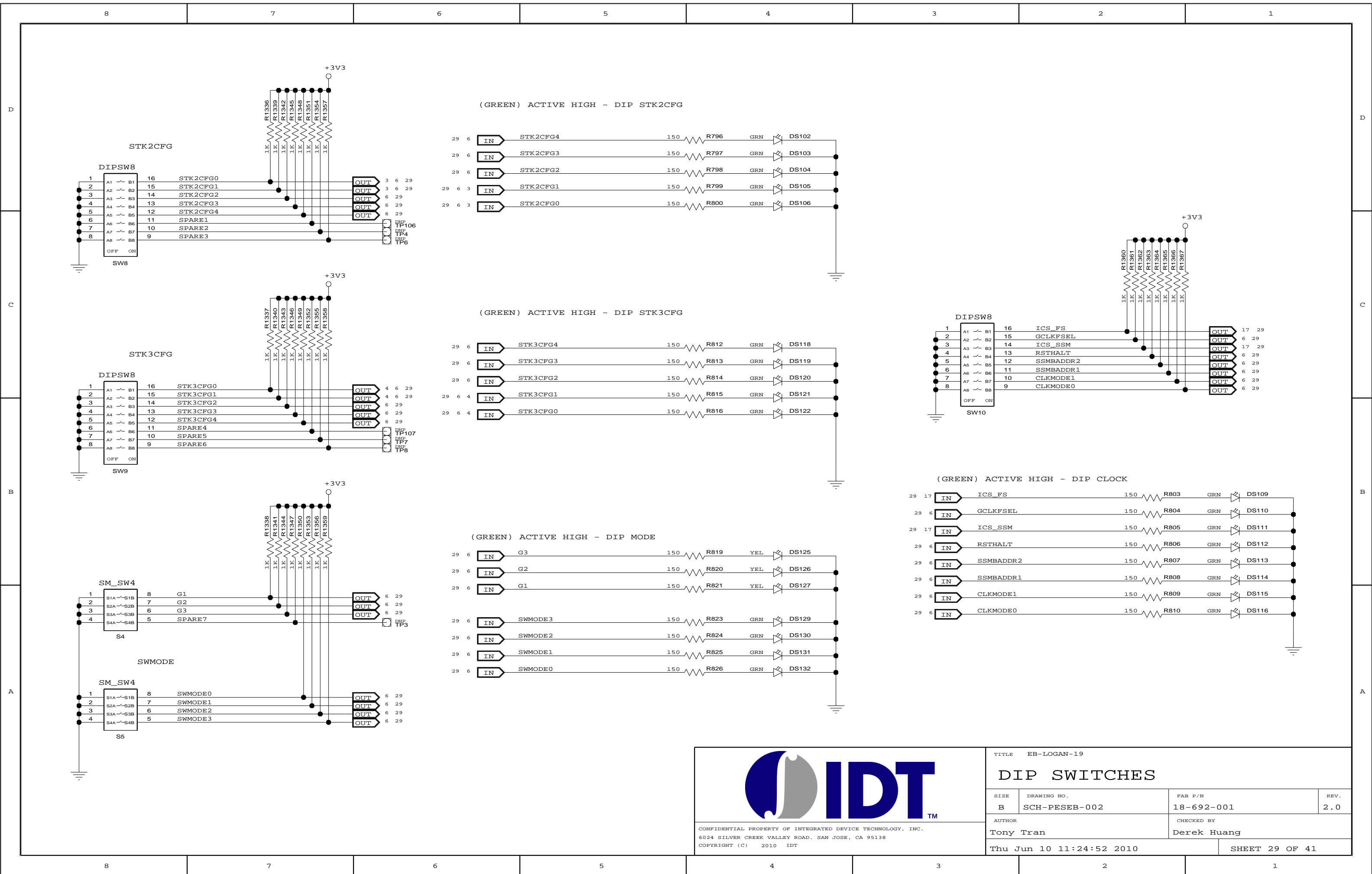

CONFIDENTIAL PROPERTY OF INTEGRATED DEVICE TECHNOLOGY, INC.
6024 SILVER CREEK VALLEY ROAD, SAN JOSE, CA 95138
COPYRIGHT (C) 2010 IDT

TITLE EB-LOGAN-19			
RESET, SMBUS, EEPROM, JTAG			
SIZE	DRAWING NO.	FAB P/N	REV.
B	SCH-PESEB-002	18-692-001	2.0
AUTHOR		CHECKED BY	
Tony Tran		Derek Huang	
Thu Jun 10 11:24:52 2010			SHEET 28 OF 41





CONFIDENTIAL PROPERTY OF INTEGRATED DEVICE TECHNOLOGY, INC.
6024 SILVER CREEK VALLEY ROAD, SAN JOSE, CA 95138
COPYRIGHT (C) 2010 IDT

TITLE EB-LOGAN-19

DIP SWITCHES

SIZE	DRAWING NO.	FAB P/N	REV.
B	SCH-PESEB-002	18-692-001	2.0
AUTHOR		CHECKED BY	
Tony Tran		Derek Huang	
Thu Jun 10 11:24:52 2010			SHEET 29 OF 41

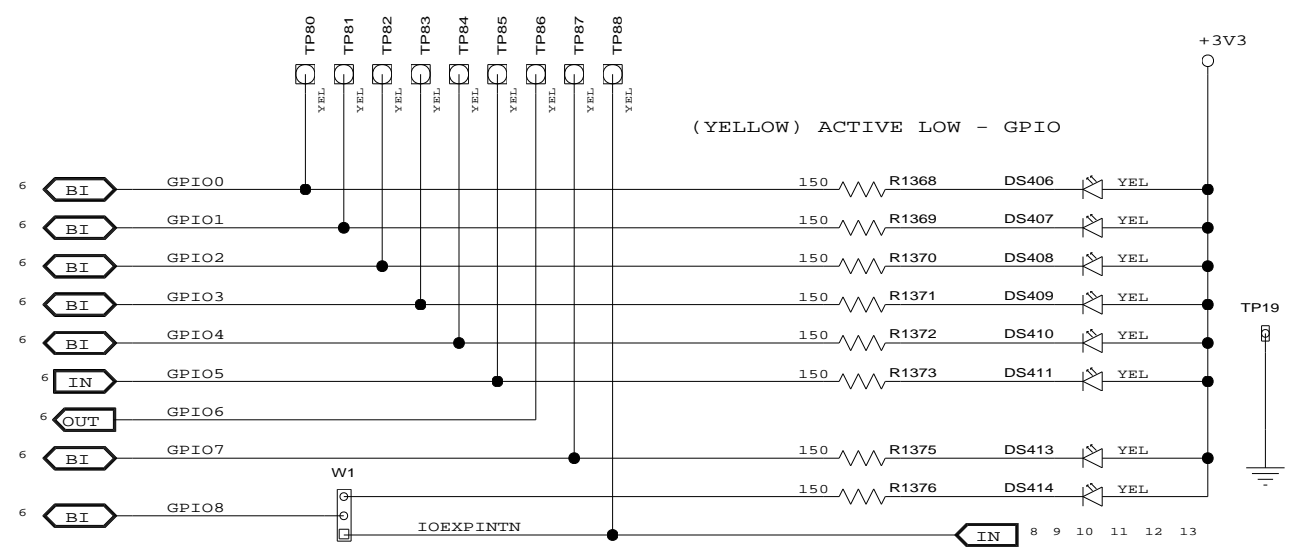

GPIO	ALT0	ALT1
0	PART0PERSTN	P16LINKUPN
1	PART1PERSTN	P16ACTIVEN
2	PART2PERSTN	P4LINKUPN
3	PART3PERSTN	P4ACTIVEN
4	FAILOVER0	P0LINKUPN
5	GPEN	P0ACTIVEN
6	FAILOVER1	FAILOVER3
7	FAILOVER2	P8LINKUPN
8	IOEXPINTN W1:1-2	P8ACTIVEN W1:2-3

(ORANGE) ACTIVE LOW - ATTENTION INPUT

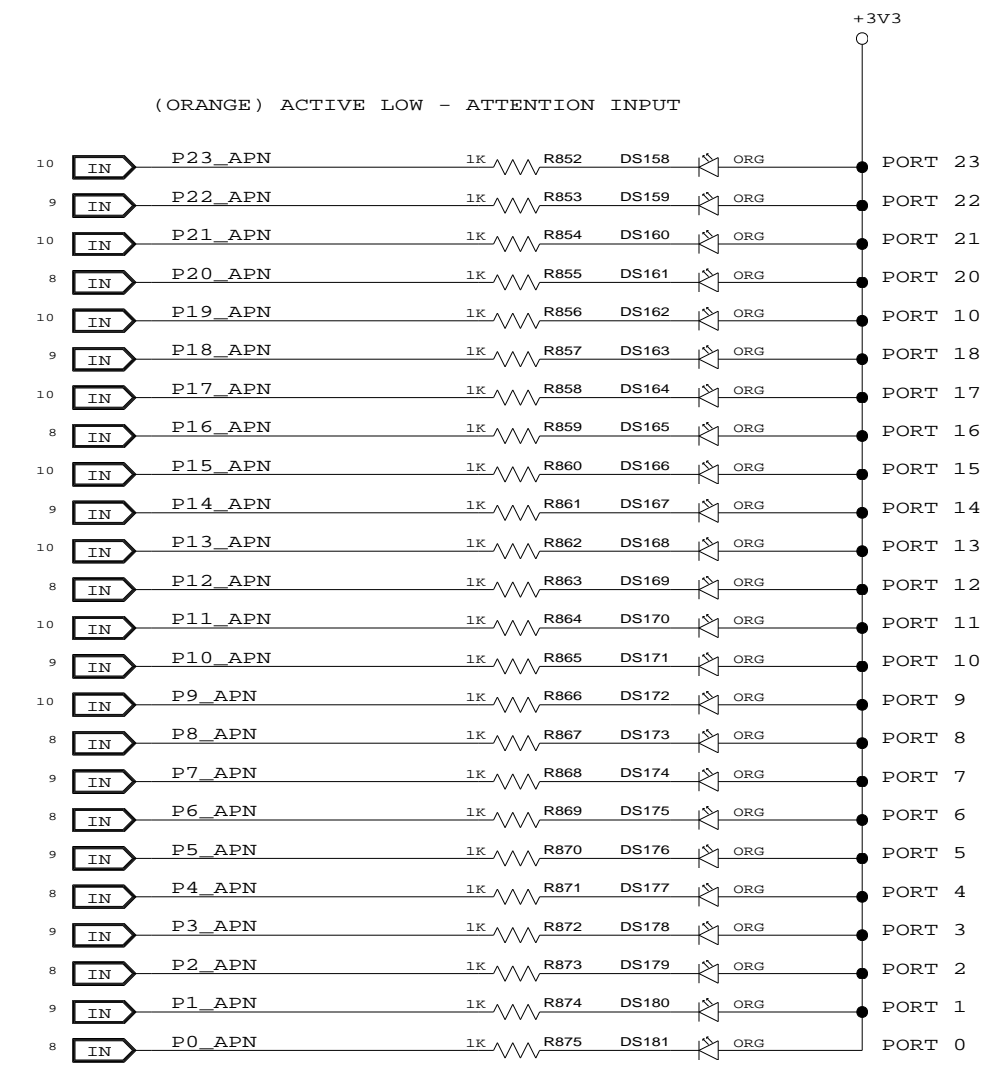

(YELLOW) ACTIVE LOW - PRESENCE DETECT

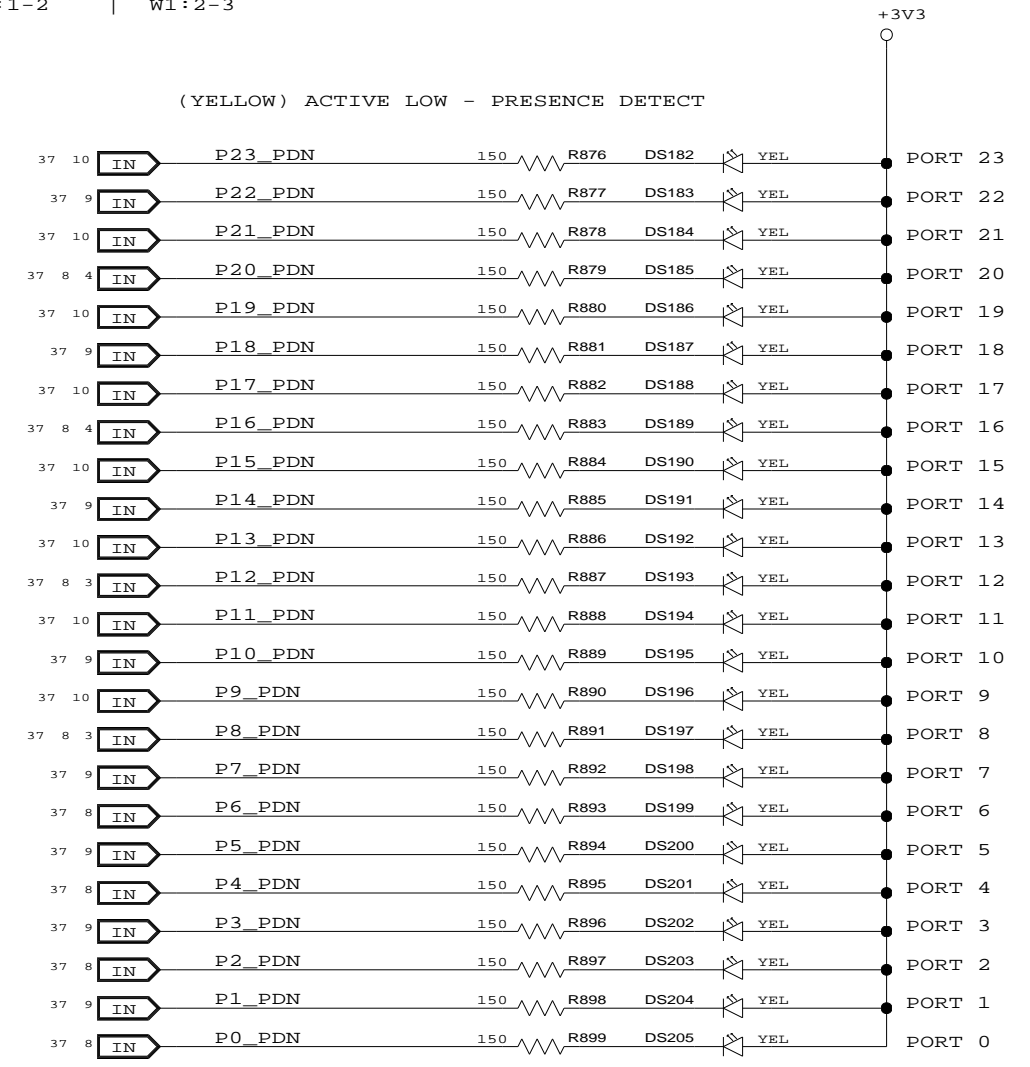

CONFIDENTIAL PROPERTY OF INTEGRATED DEVICE TECHNOLOGY, INC.
6024 SILVER CREEK VALLEY ROAD, SAN JOSE, CA 95138
COPYRIGHT (C) 2010 IDT

TITLE EB-LOGAN-19			
LED - PORT STATUS (1 OF 7)			
SIZE B	DRAWING NO. SCH-PESEB-002	FAB P/N 18-692-001	REV. 2.0
AUTHOR Tony Tran		CHECKED BY Derek Huang	
Thu Jun 10 11:24:53 2010			SHEET 30 OF 41

(RED) ACTIVE LOW - POWER FAULT

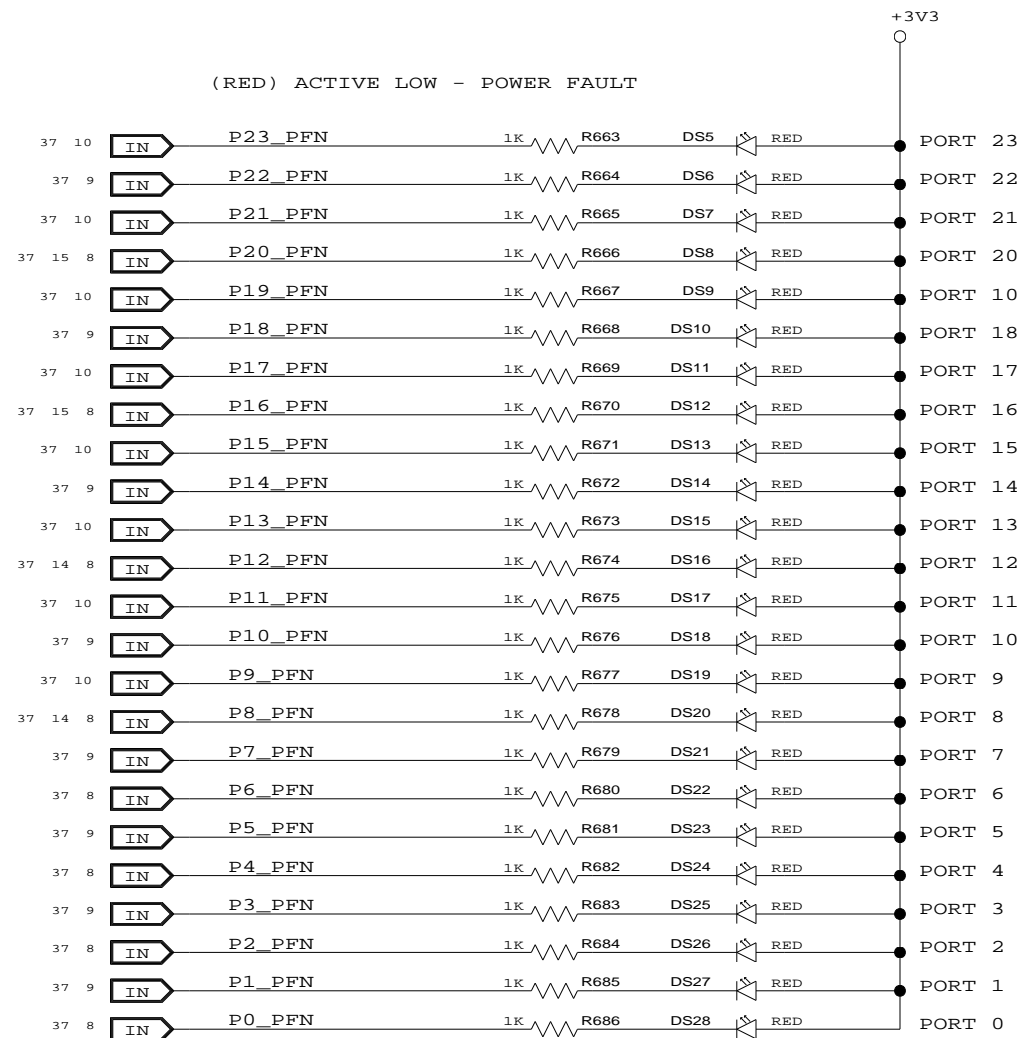

(GREEN) ACTIVE LOW - POWER GOOD

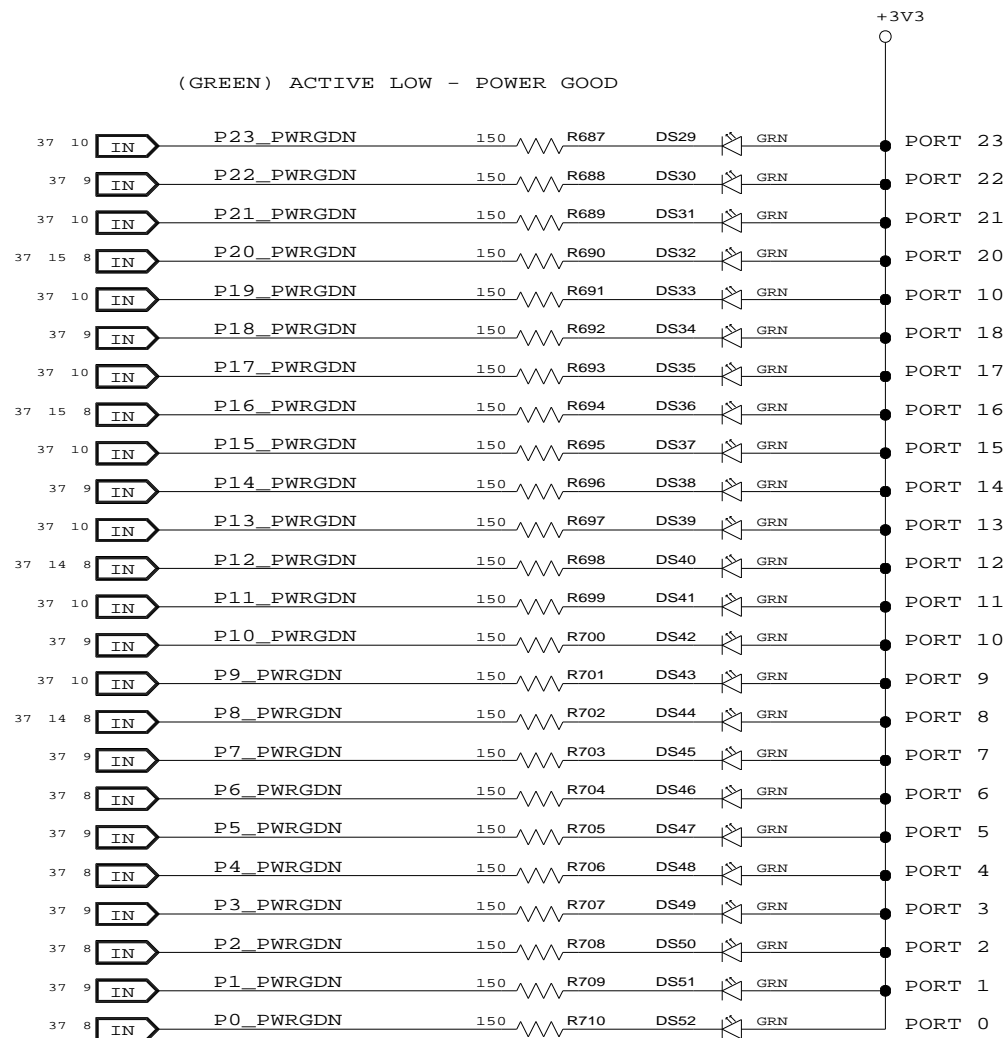

CONFIDENTIAL PROPERTY OF INTEGRATED DEVICE TECHNOLOGY, INC.
6024 SILVER CREEK VALLEY ROAD, SAN JOSE, CA 95138
COPYRIGHT (C) 2010 IDT

TITLE EB-LOGAN-19

LED - PORT STATUS (2 OF 7)

SIZE B	DRAWING NO. SCH-PESEB-002	FAB P/N 18-692-001	REV. 2.0
AUTHOR Tony Tran		CHECKED BY Derek Huang	
Thu Jun 10 11:24:53 2010			SHEET 31 OF 41

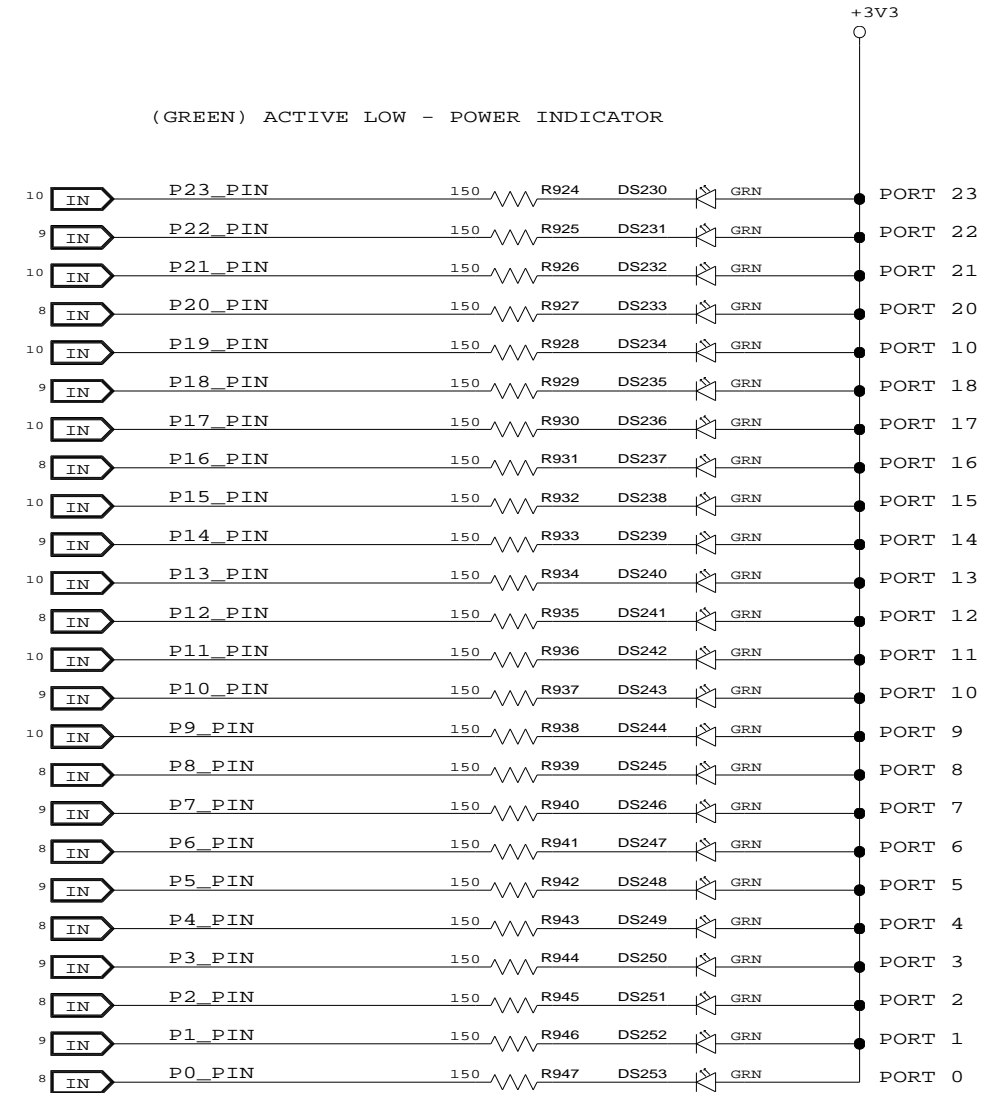
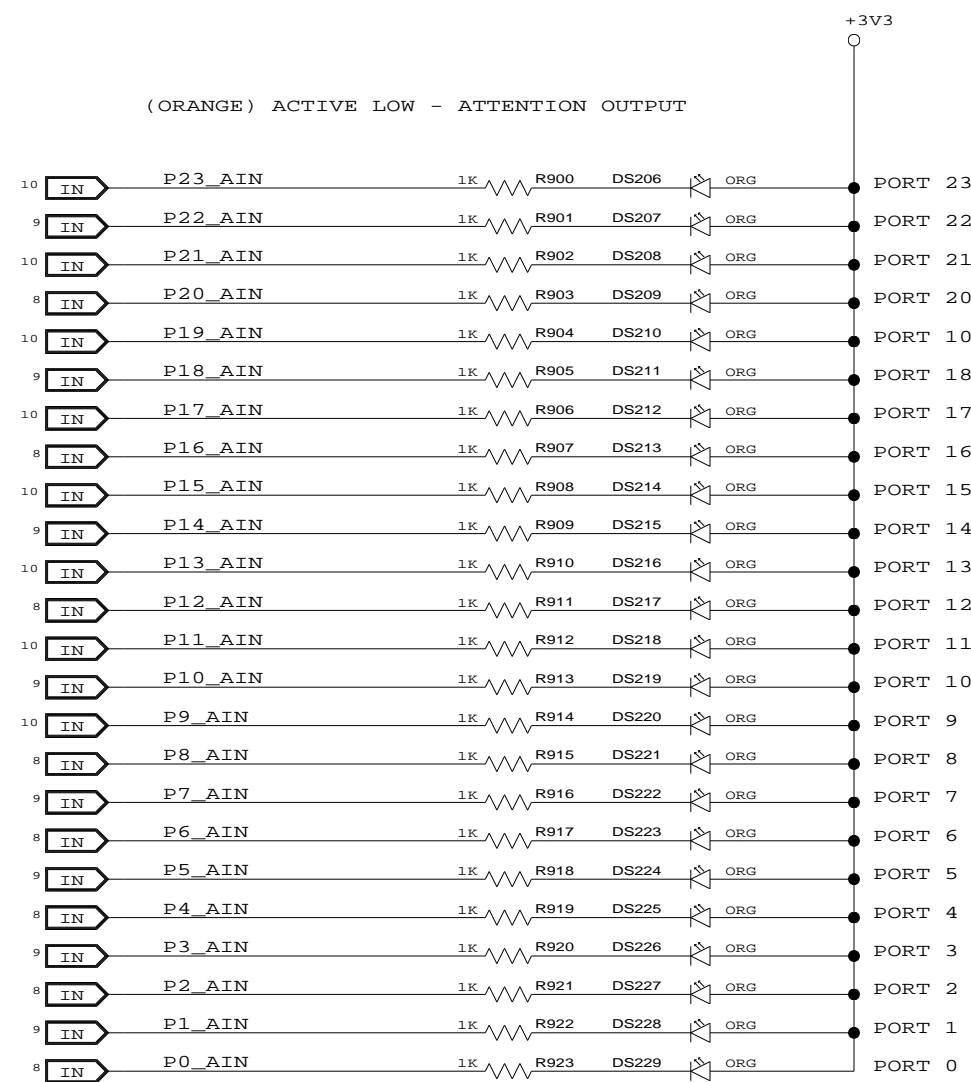

CONFIDENTIAL PROPERTY OF INTEGRATED DEVICE TECHNOLOGY, INC.
6024 SILVER CREEK VALLEY ROAD, SAN JOSE, CA 95138
COPYRIGHT (C) 2010 IDT

TITLE EB-LOGAN-19

LED - PORT STATUS (3 OF 7)

SIZE	DRAWING NO.	FAB P/N	REV.
B	SCH-PESEB-002	18-692-001	2.0
AUTHOR Tony Tran		CHECKED BY Derek Huang	
Thu Jun 10 11:24:53 2010			SHEET 32 OF 41

(GREEN) ACTIVE HIGH - POWER ENABLE

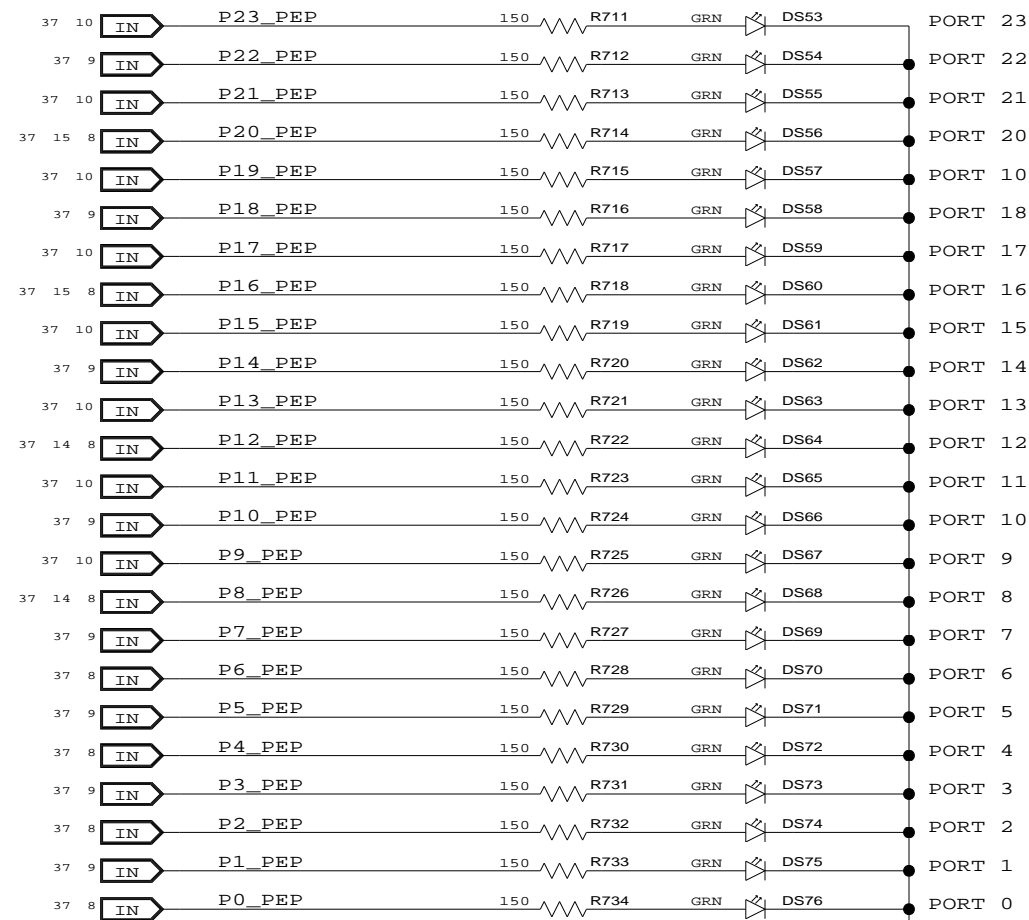

(RED) ACTIVE LOW - HP SLOT RST

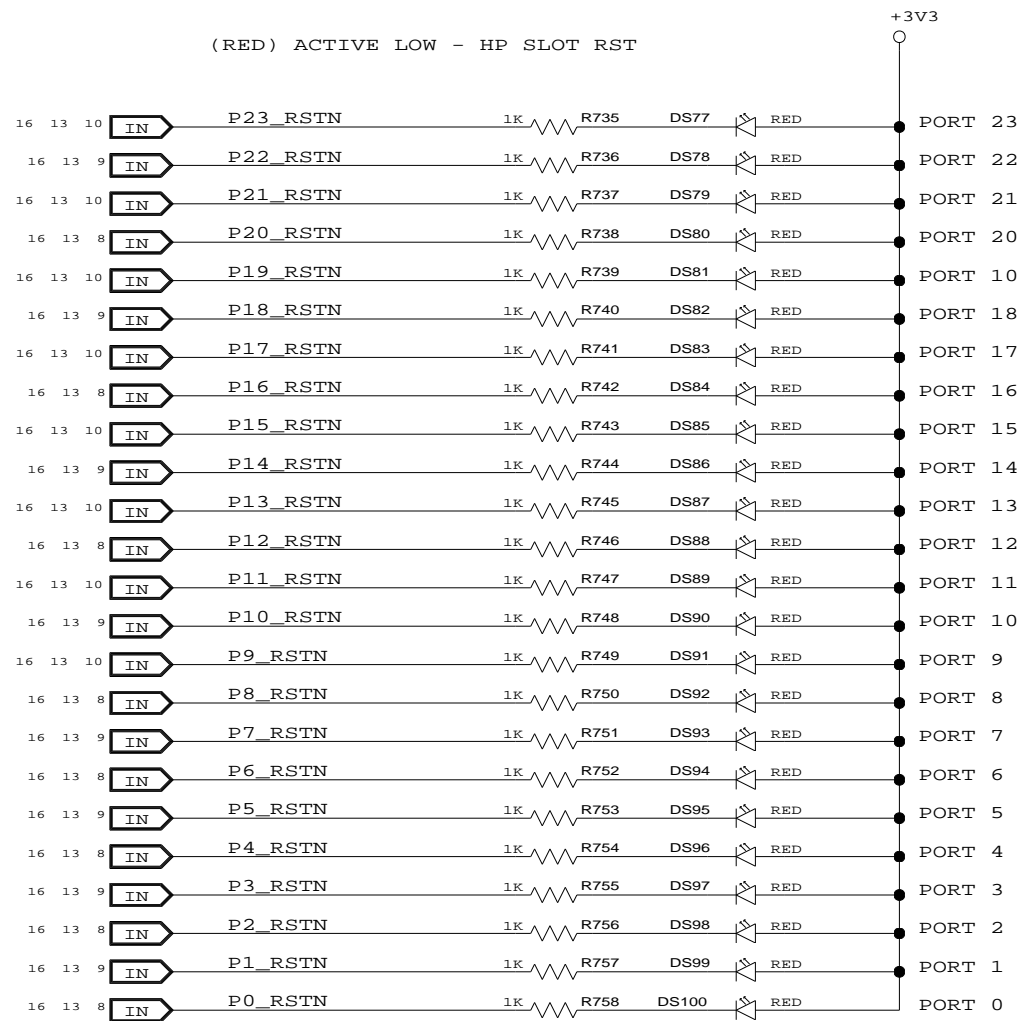

CONFIDENTIAL PROPERTY OF INTEGRATED DEVICE TECHNOLOGY, INC.
6024 SILVER CREEK VALLEY ROAD. SAN JOSE, CA 95138
COPYRIGHT (C) 2010 IDT

TITLE EB-LOGAN-19

LED - PORT STATUS (4 OF 7)

SIZE	DRAWING NO.	FAB P/N	REV.
B	SCH-PESEB-002	18-692-001	2.0
AUTHOR Tony Tran		CHECKED BY Derek Huang	
Thu Jun 10 11:24:54 2010			SHEET 33 OF 41

8

7

6

5

4

3

2

1

(GREEN) ACTIVE HIGH - INTERLOCK INPUT

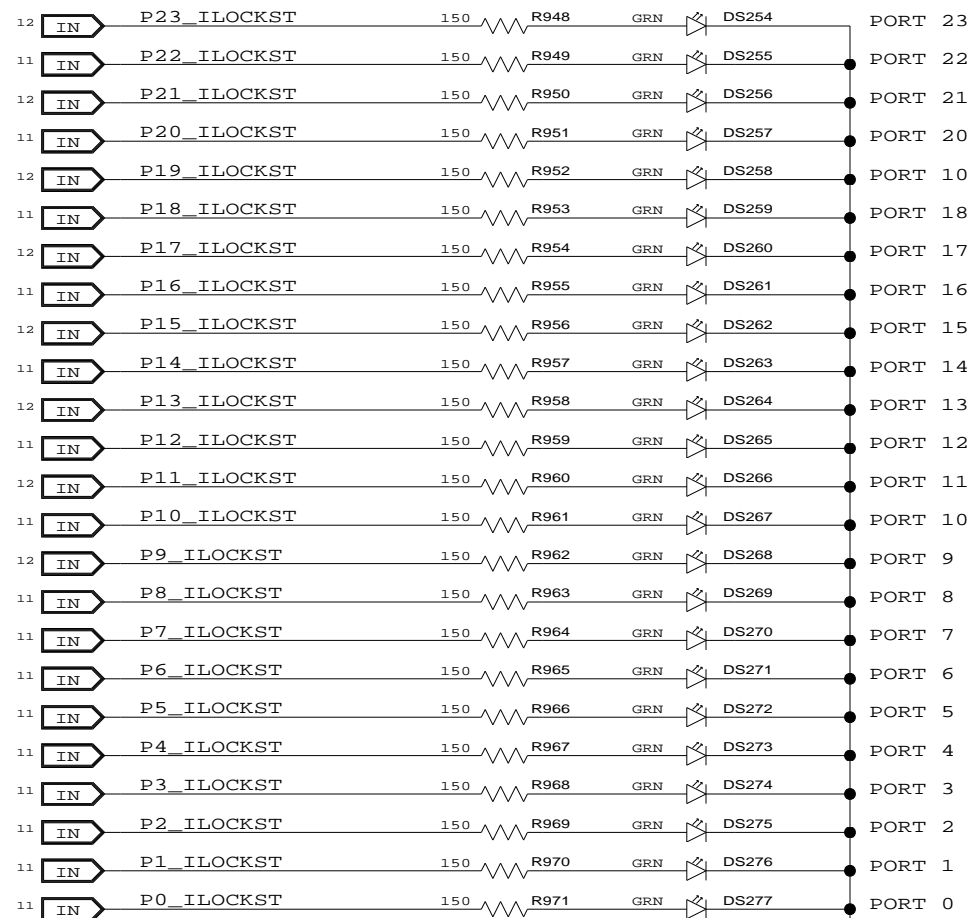

(RED) ACTIVE LOW - MRL

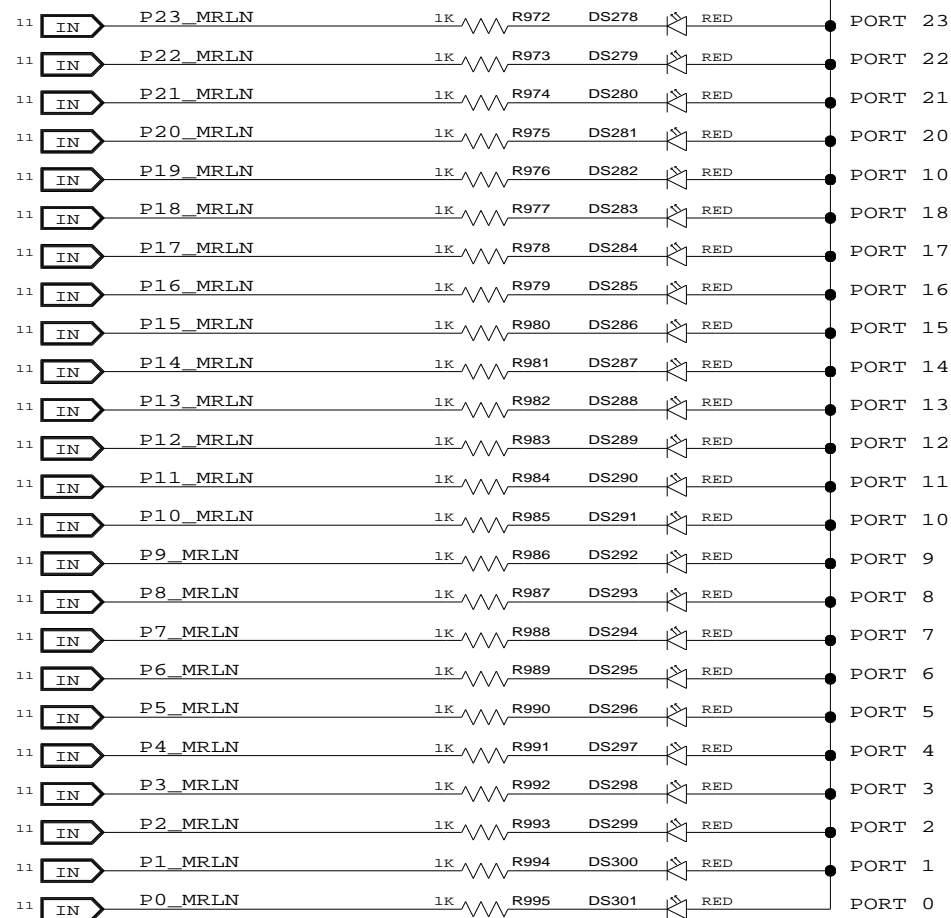

CONFIDENTIAL PROPERTY OF INTEGRATED DEVICE TECHNOLOGY, INC.
 6024 SILVER CREEK VALLEY ROAD, SAN JOSE, CA 95138
 COPYRIGHT (C) 2010 IDT

TITLE EB-LOGAN-19

LED - PORT STATUS (5 OF 7)

SIZE B	DRAWING NO. SCH-PESEB-002	FAB P/N 18-692-001	REV. 2.0
-----------	------------------------------	-----------------------	-------------

AUTHOR Tony Tran	CHECKED BY Derek Huang
---------------------	---------------------------

Thu Jun 10 11:24:54 2010

SHEET 34 OF 41

8

7

6

5

4

3

2

1

(RED) ACTIVE LOW - PARTITION FUND. RESET

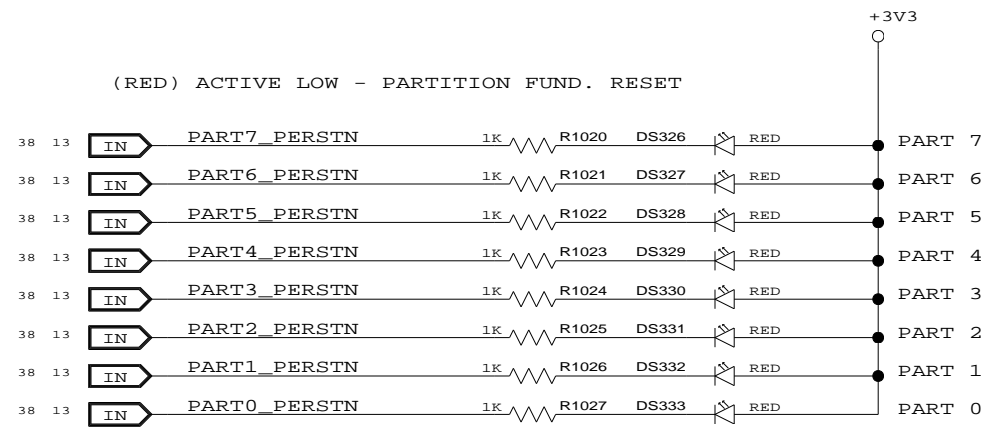

(RED) ACTIVE LOW - SLOT HEADER RESET

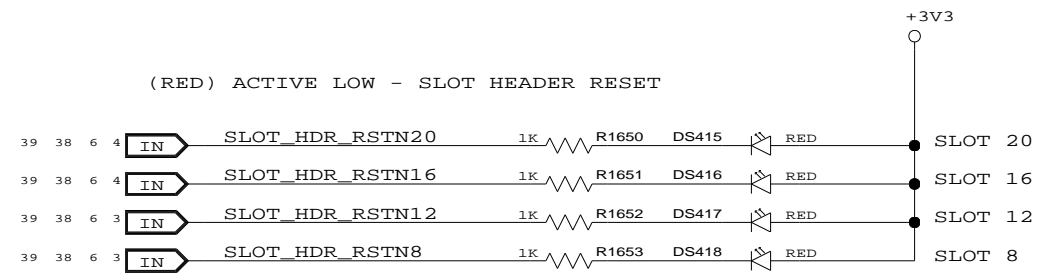

(GREEN) ACTIVE HIGH - INTERLOCK OUTPUT

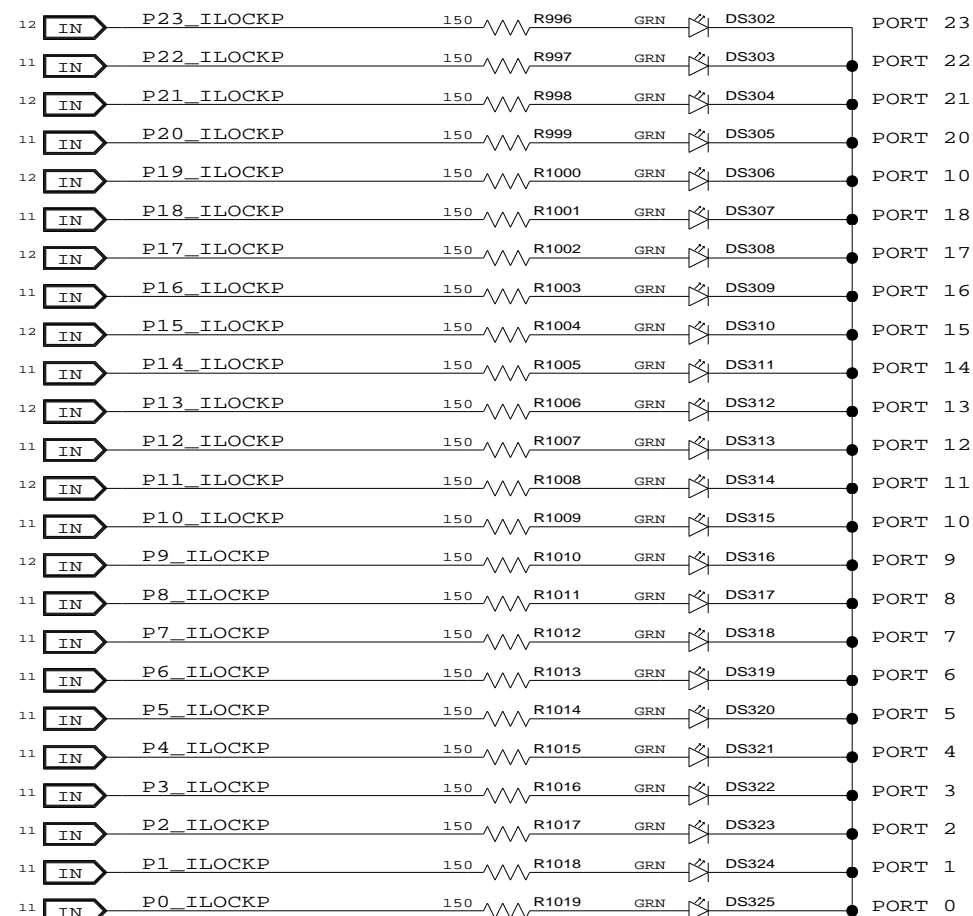

CONFIDENTIAL PROPERTY OF INTEGRATED DEVICE TECHNOLOGY, INC.
6024 SILVER CREEK VALLEY ROAD, SAN JOSE, CA 95138
COPYRIGHT (C) 2010 IDT

TITLE EB-LOGAN-19

LED - PORT STATUS (6 OF 7)

SIZE	DRAWING NO.	FAB P/N	REV.
B	SCH-PESEB-002	18-692-001	2.0

AUTHOR	CHECKED BY
Tony Tran	Derek Huang

Thu Jun 10 11:24:54 2010

SHEET 35 OF 41

(GREEN) ACTIVE LOW - LINK UP

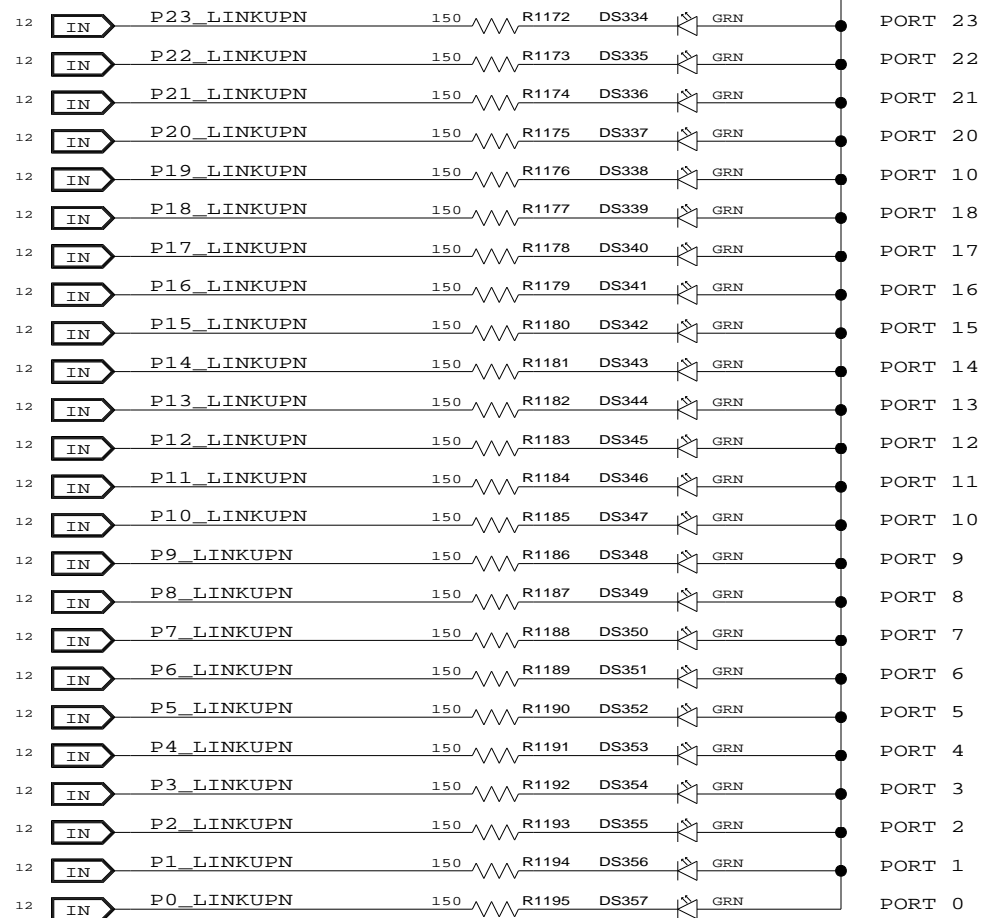

(BLUE) ACTIVE LOW - LINK ACTIVITY

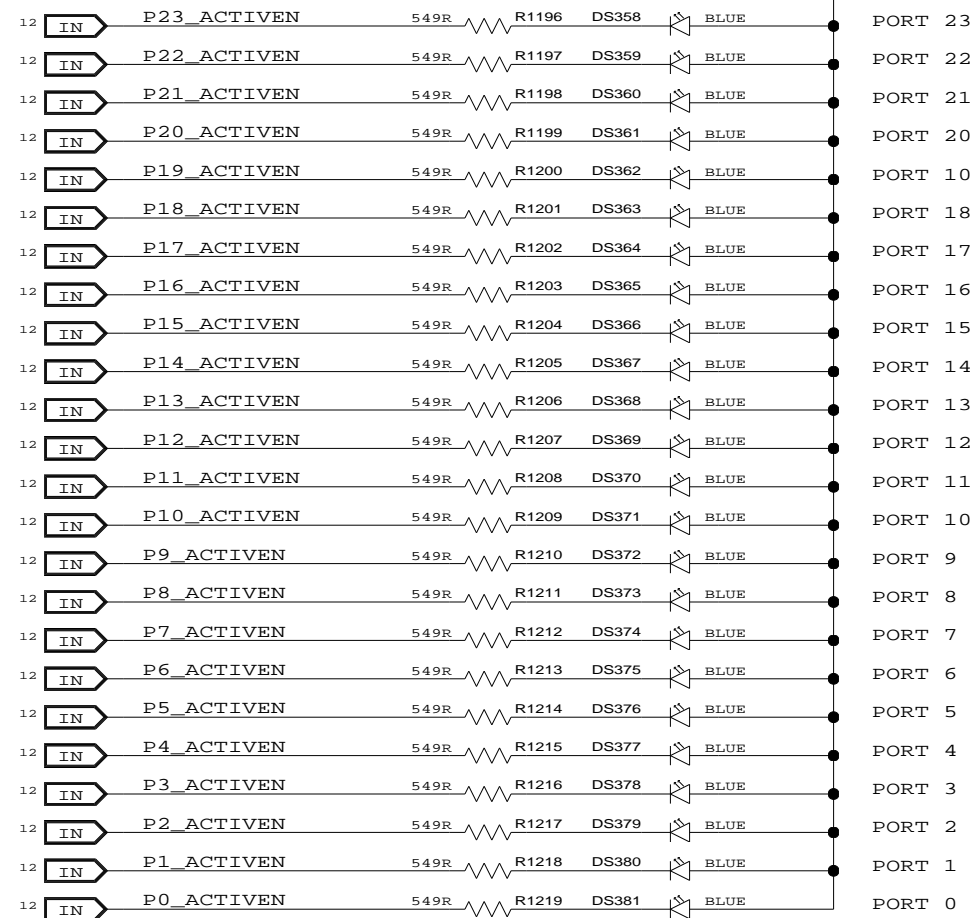

CONFIDENTIAL PROPERTY OF INTEGRATED DEVICE TECHNOLOGY, INC.
6024 SILVER CREEK VALLEY ROAD. SAN JOSE, CA 95138
COPYRIGHT (C) 2010 IDT

TITLE EB-LOGAN-19

LED - PORT STATUS (7 OF 7)

SIZE B	DRAWING NO. SCH-PESEB-002	FAB P/N 18-692-001	REV. 2.0
-----------	------------------------------	-----------------------	-------------

AUTHOR Tony Tran	CHECKED BY Derek Huang
---------------------	---------------------------

Thu Jun 10 11:24:55 2010

SHEET 36 OF 41

SLOT_RESETN
 CARD_PRESENTN
 WAKEN
 POWERGOOD
 PWR_FLTN
 PWR_ENABLE
 CLOCK_ENABLEN
 PS_ENABLEN
 CABLE SENSE

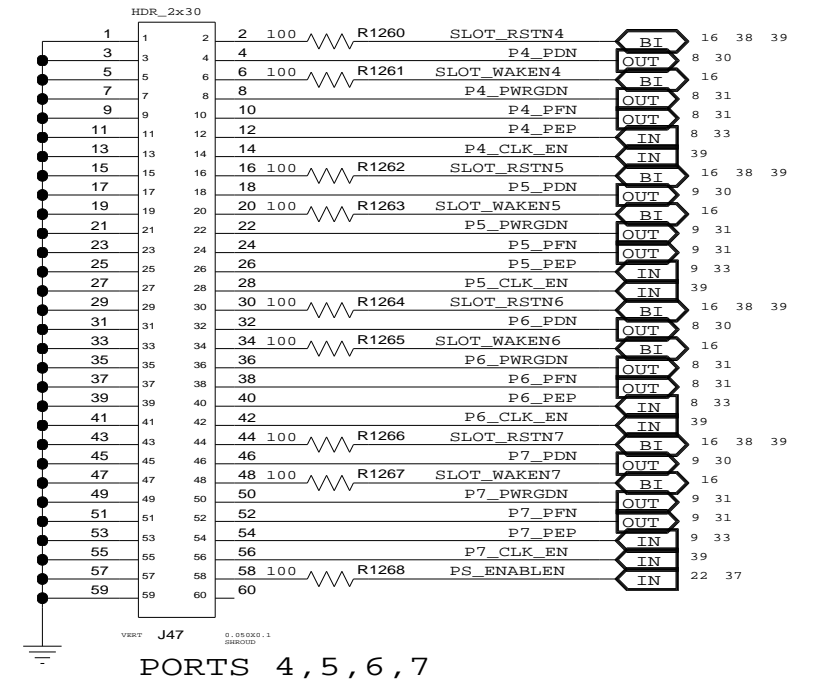
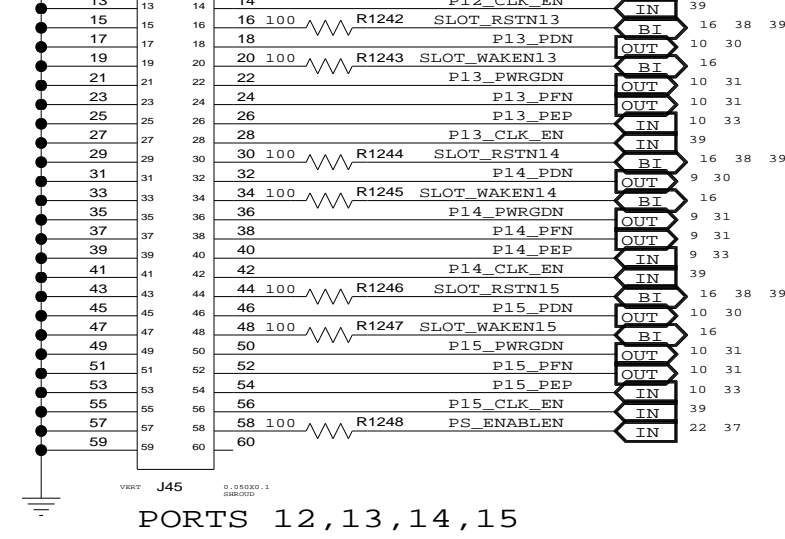
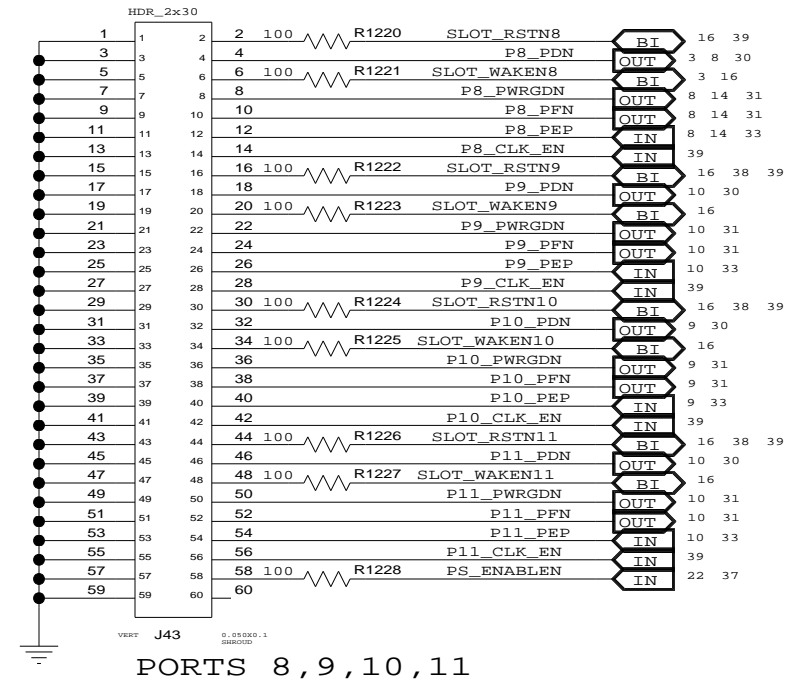

SLOT_RESETN
 CARD_PRESENTN
 WAKEN
 POWERGOOD
 PWR_FLTN
 PWR_ENABLE
 CLOCK_ENABLEN
 PS_ENABLEN
 CABLE SENSE

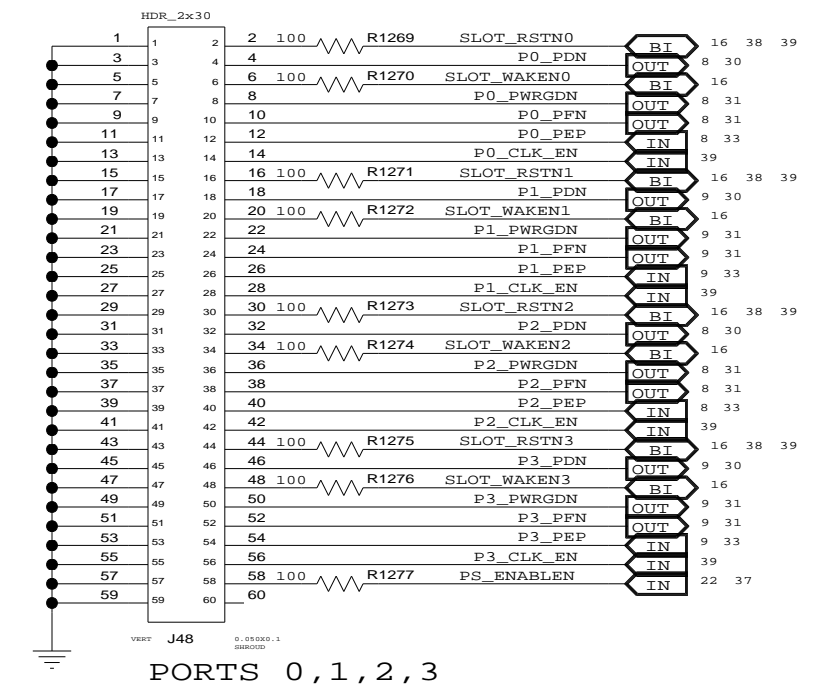
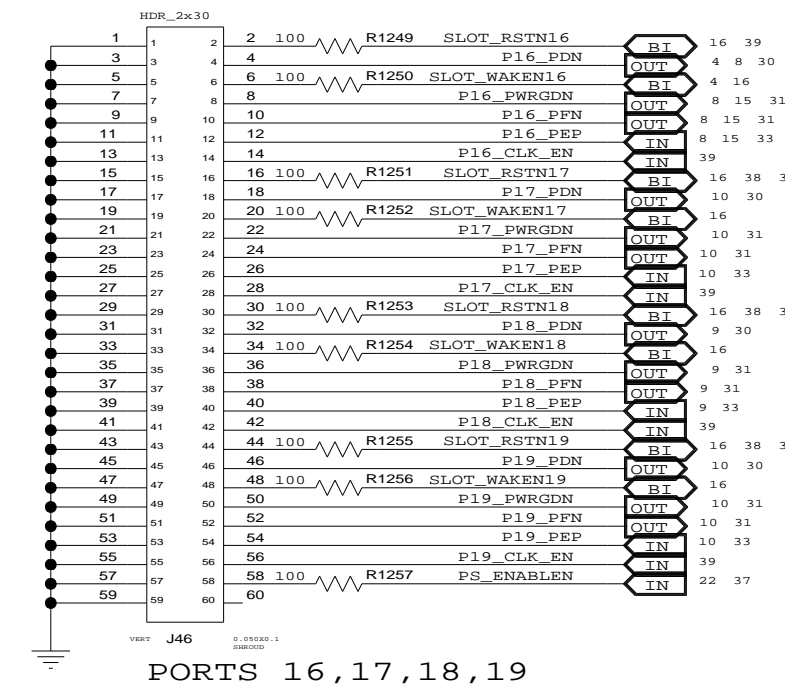
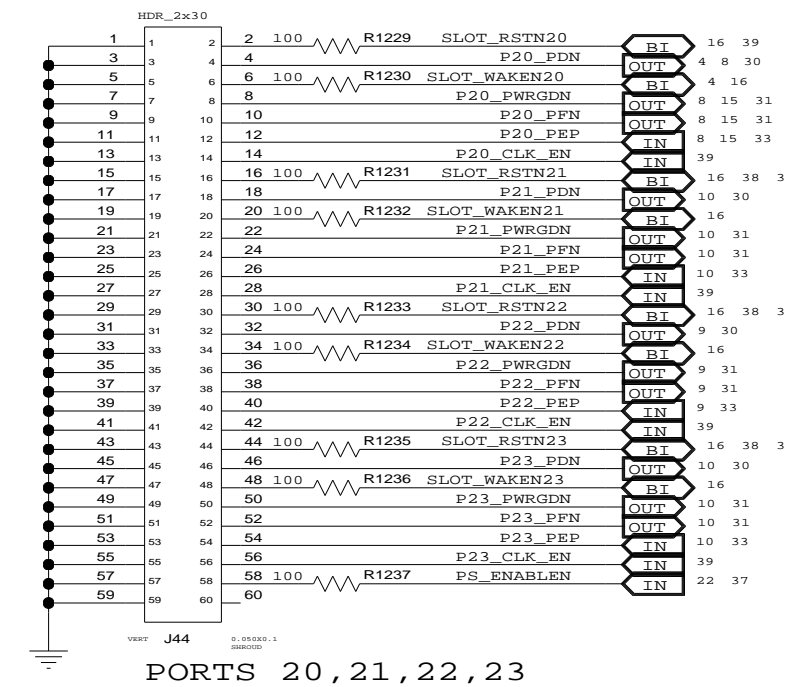

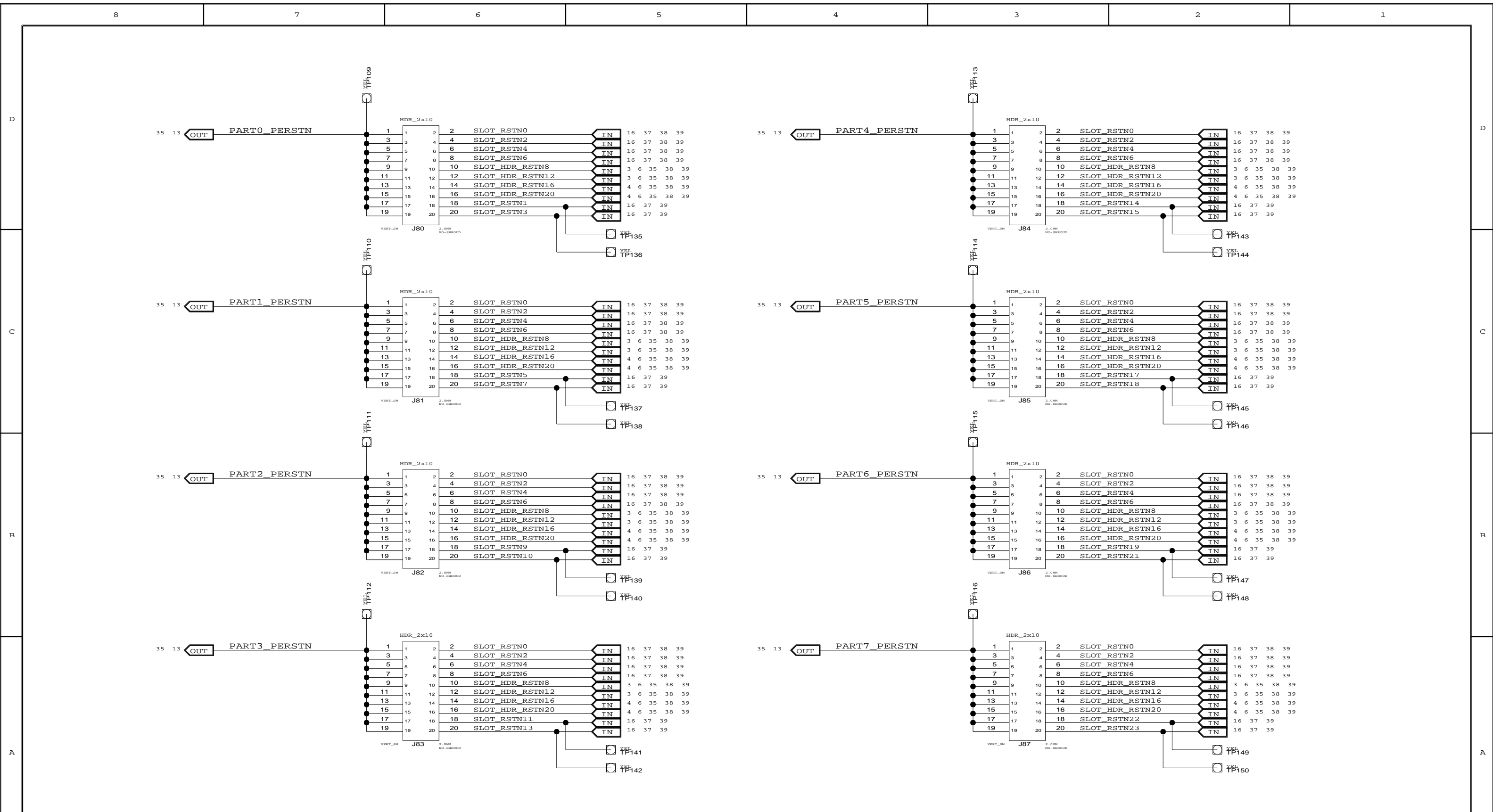

		TITLE EB-LOGAN-19	
		PARTITION RESET SELECT HEADERS	
SIZE	DRAWING NO.	FAB P/N	REV.
B	SCH-PESEB-002	18-692-001	2.0
AUTHOR		CHECKED BY	
Tony Tran		Derek Huang	
Thu Jun 10 11:24:56 2010			SHEET 38 OF 41

CONFIDENTIAL PROPERTY OF INTEGRATED DEVICE TECHNOLOGY, INC.
 6024 SILVER CREEK VALLEY ROAD. SAN JOSE, CA 95138
 COPYRIGHT (C) 2010 IDT

NOTE: DNP JUMPERS WHEN IOEXPANDER IS ENABLED

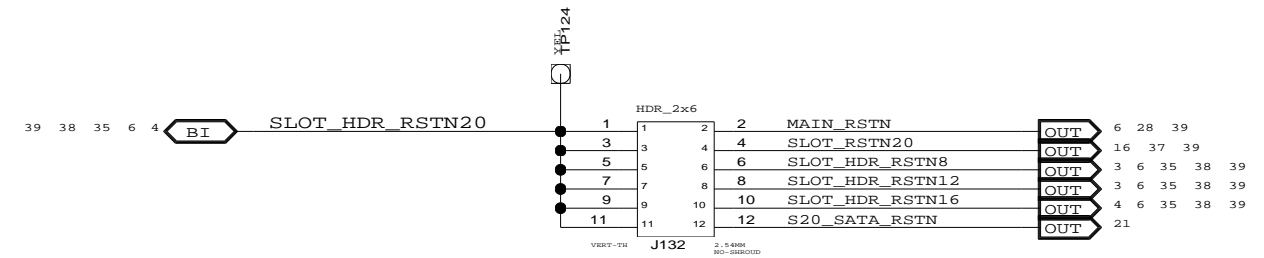
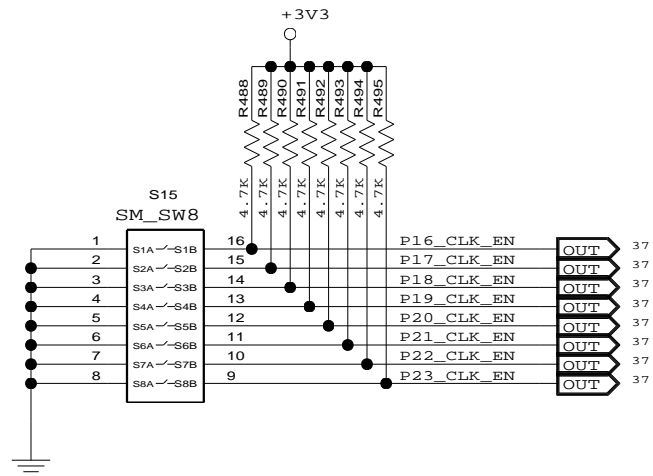
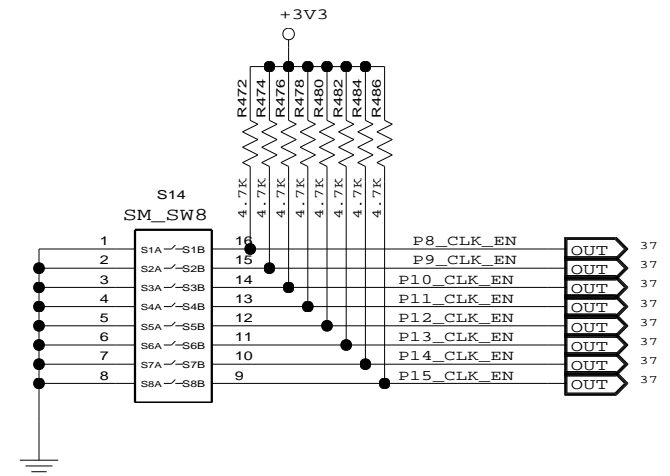
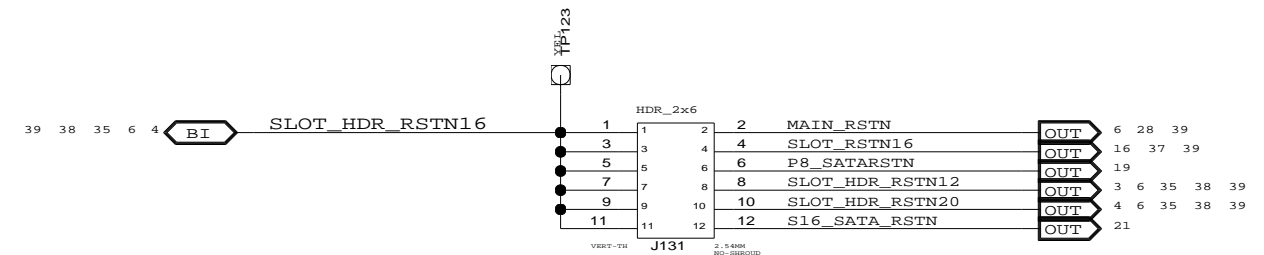
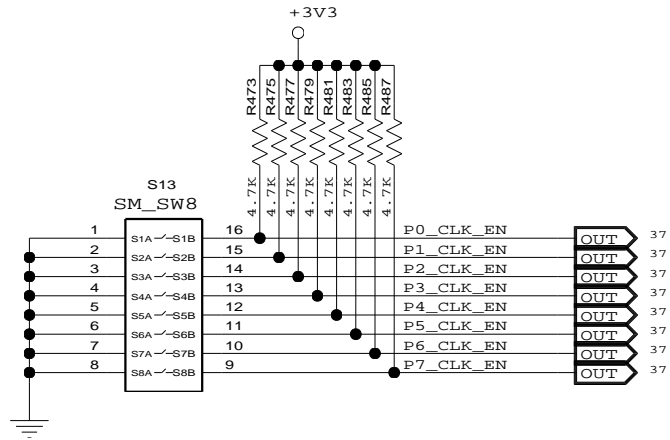
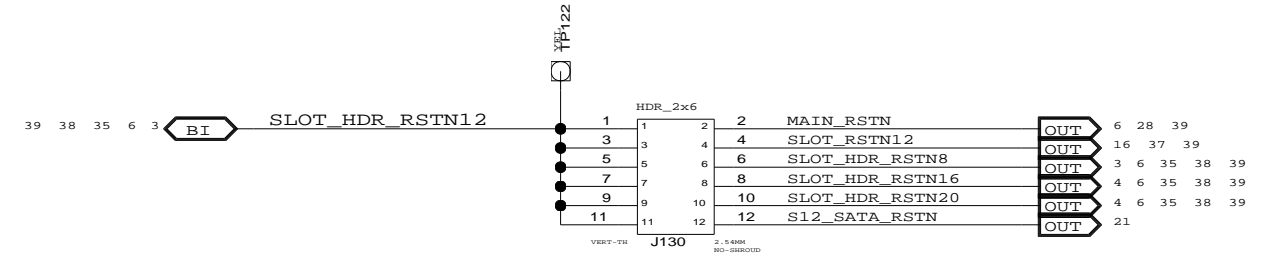
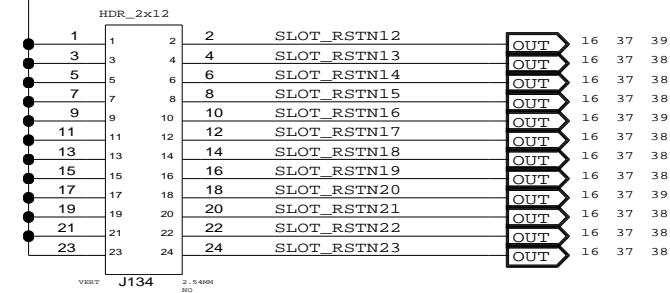
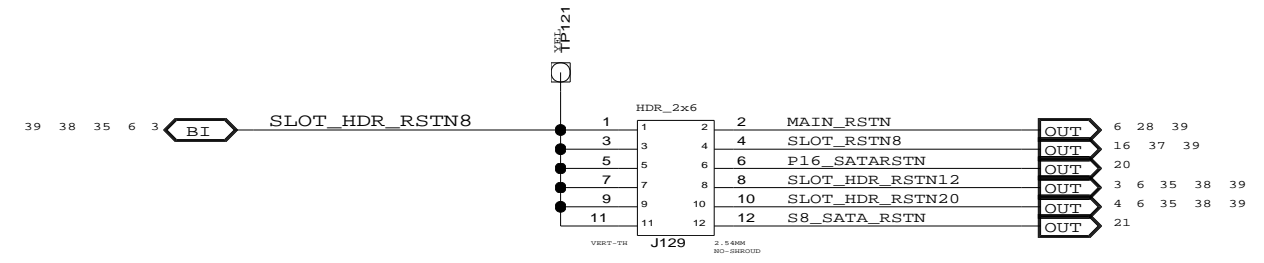
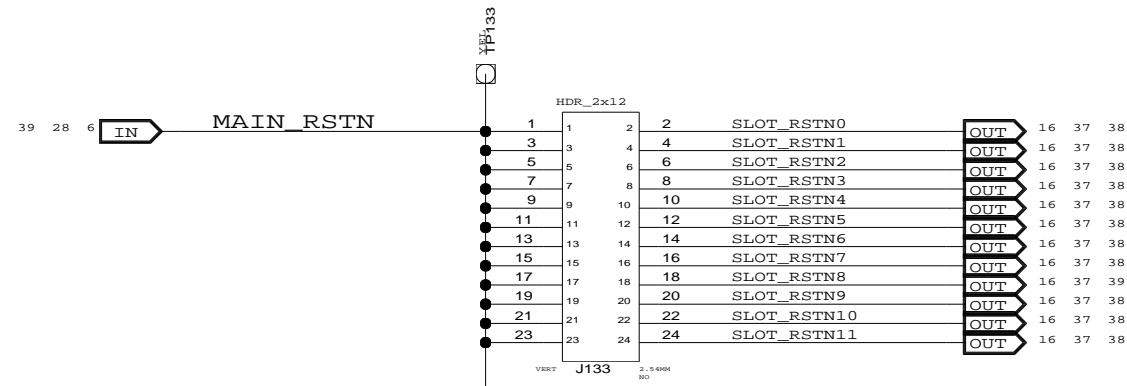

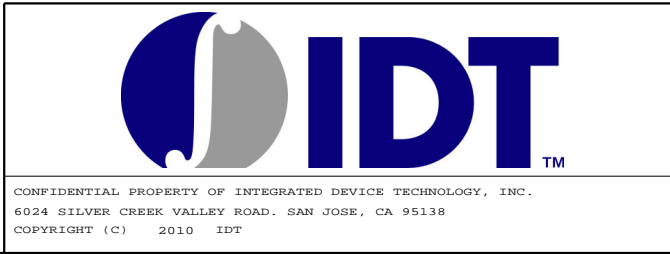
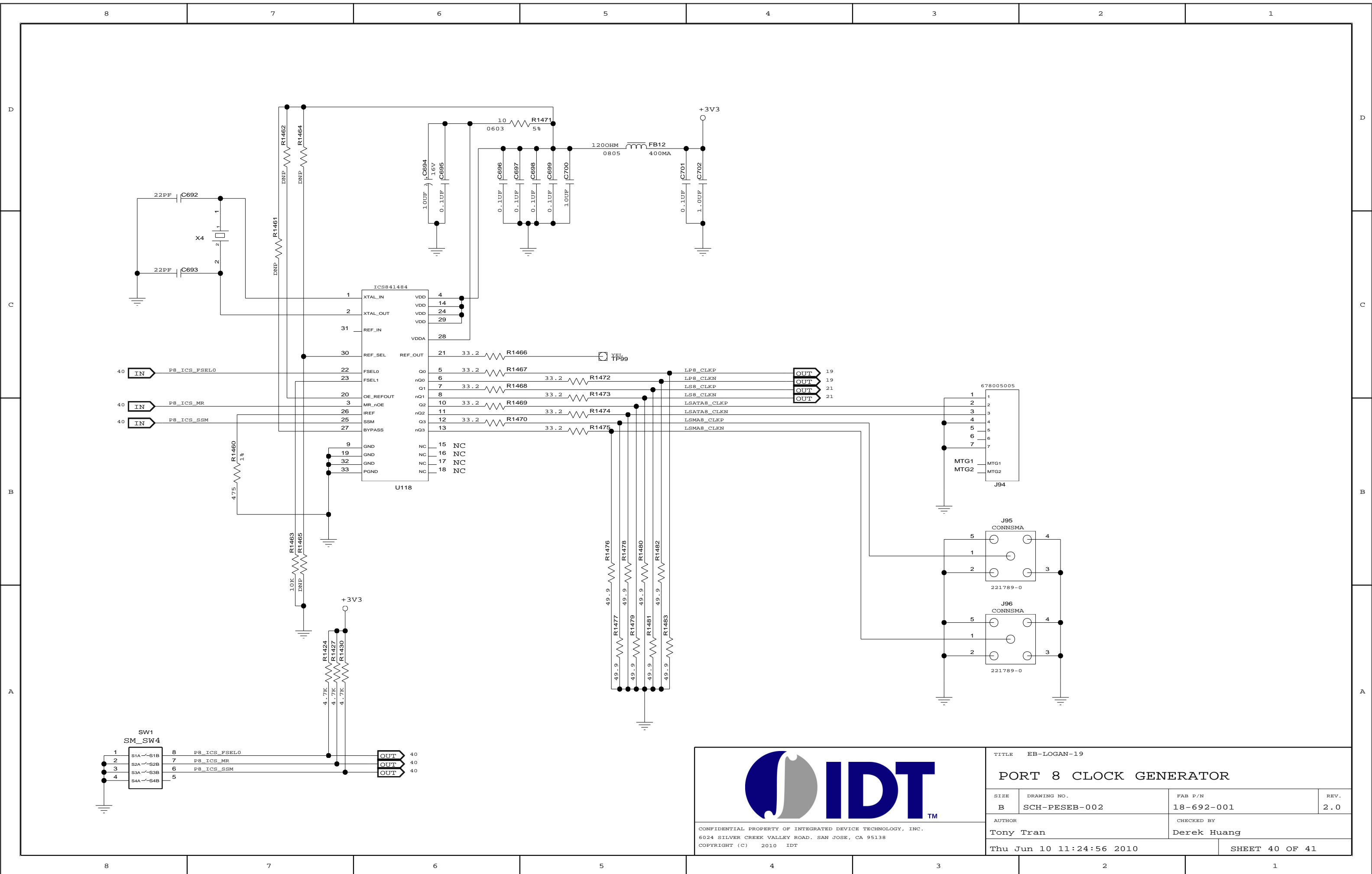

CONFIDENTIAL PROPERTY OF INTEGRATED DEVICE TECHNOLOGY, INC.
6024 SILVER CREEK VALLEY ROAD, SAN JOSE, CA 95138
COPYRIGHT (C) 2010 IDT

TITLE EB-LOGAN-19			
SLOT RESET SELECT HEADERS			
SIZE	DRAWING NO.	FAB P/N	REV.
B	SCH-PESEB-002	18-692-001	2.0
AUTHOR		CHECKED BY	
Tony Tran		Derek Huang	
Thu Jun 10 11:24:56 2010			SHEET 39 OF 41

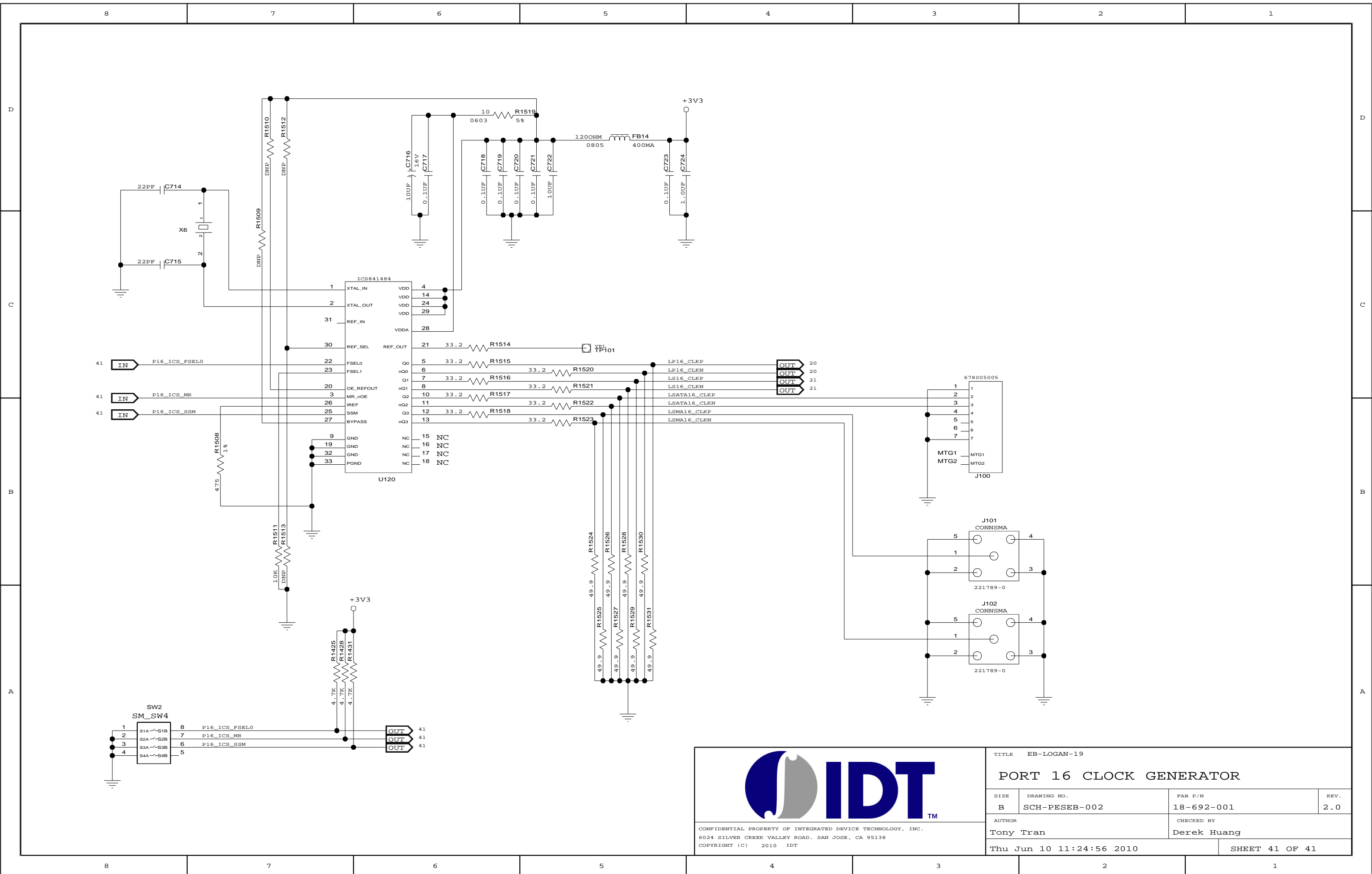

TITLE EB-LOGAN-19			
PORT 8 CLOCK GENERATOR			
SIZE	DRAWING NO.	FAB P/N	REV.
B	SCH-PESEB-002	18-692-001	2.0
AUTHOR		CHECKED BY	
Tony Tran		Derek Huang	
Thu Jun 10 11:24:56 2010			SHEET 40 OF 41





CONFIDENTIAL PROPERTY OF INTEGRATED DEVICE TECHNOLOGY, INC.
6024 SILVER CREEK VALLEY ROAD, SAN JOSE, CA 95138
COPYRIGHT (C) 2010 IDT

TITLE EB-LOGAN-19

PORT 16 CLOCK GENERATOR

SIZE	DRAWING NO.	FAB P/N	REV.
B	SCH-PESEB-002	18-692-001	2.0
AUTHOR		CHECKED BY	
Tony Tran		Derek Huang	
Thu Jun 10 11:24:56 2010			SHEET 41 OF 41