

ISL72814SEH, ISL73814SEH

R34ST0001EU0100

Single Event Effects (SEE) Testing

Rev.1.00

Jan 8, 2019

## Introduction

The intense proton and heavy ion environment encountered in space applications can cause a variety of Single Event Effects (SEE) in electronic circuitry, including Single Event Upset (SEU), Single Event Transient (SET), Single Event Functional Interrupt (SEFI), Single Event Latch-Up (SEL), Single Event Gate Rupture (SEGR), and Single Event Burnout (SEB). SEE can lead to system-level performance issues including disruption, degradation, and destruction. For predictable and reliable space system operation, individual electronic components should be characterized to determine their SEE response. This report discusses the results of SEE testing performed on the [ISL72814SEH](#) product. Although this report was written for the ISL72814SEH, it applies equally to the [ISL73814SEH](#), which is the same silicon die and differs only in the total ionizing dose assurance testing.

## Product Description

The ISL72814SEH is a radiation hardened, high-voltage, high-current switch array fabricated using Renesas' proprietary complementary bipolar PR40 Silicon-on-Insulator (SOI) process. The device integrates 16 switches that feature greater than a 42V breakdown voltage. The maximum DC current rating for each switch is 700mA.

To reduce solution size and increase system density, the ISL72814SEH integrates a 4-bit to 16-line decoder (plus enable pin). This conveniently selects 1 of the 16 available switch channels that provide switching from a positive supply to a common ground. The inputs to the decoder are four TTL/CMOS compatible address lines and one enable line.

The ISL72814SEH operates across the military temperature range from -55°C to +125°C and is available in a 28 Ld hermetic ceramic flat pack (CDFP) package.

The ISL72814SEH samples tested for this report were from the innovative lot XCP2E, wafer 09. The samples were packaged without lids to allow irradiation, and only room temperature testing of the parts was done. No burn-in stressing was done on the parts.

## Related Literature

For a full list of related documents, visit our website:

- [ISL72814SEH](#), [ISL73814SEH](#) device pages

## 1. Test Description

### 1.1 Test Objective

The testing was intended to find the limits of the  $V_{CC}$  supply and channel voltages for avoiding destructive single event effects (such as SEB) at a Linear Energy Transfer (LET) of  $86\text{MeV}\cdot\text{cm}^2/\text{mg}$  (gold). Because of the SOI process, the part is inherently immune to single event latch-up (SEL). In addition, testing was carried out to look for significant single event transients (SET) impacting the switch channel activity at LET of  $86\text{MeV}\cdot\text{cm}^2/\text{mg}$  (gold),  $28\text{MeV}\cdot\text{cm}^2/\text{mg}$  (krypton), and  $20\text{MeV}\cdot\text{cm}^2/\text{mg}$  (copper).

### 1.2 Test Facility

Single event effects testing was done at the Texas A&M University (TAMU) Radiation Effects Facility of the Cyclotron Institute in College Station Texas. This facility is coupled to a K500 superconducting cyclotron which is capable of supplying a wide range of ion species and flux. The testing referred to here was done on June 19 to 20, 2018.

### 1.3 Test Set-Up

The schematic for SEE testing is shown [Figure 1](#). The address lines were all grounded so that only CH0 was selectable using the EN pin. The OFF channels CH2 through CH15 were all wired in parallel to terminal CHX which was tied through a  $100\Omega$  resistor to VCOM (COM). The OFF channel CH1 was brought out separately to allow monitoring of a single OFF channel.

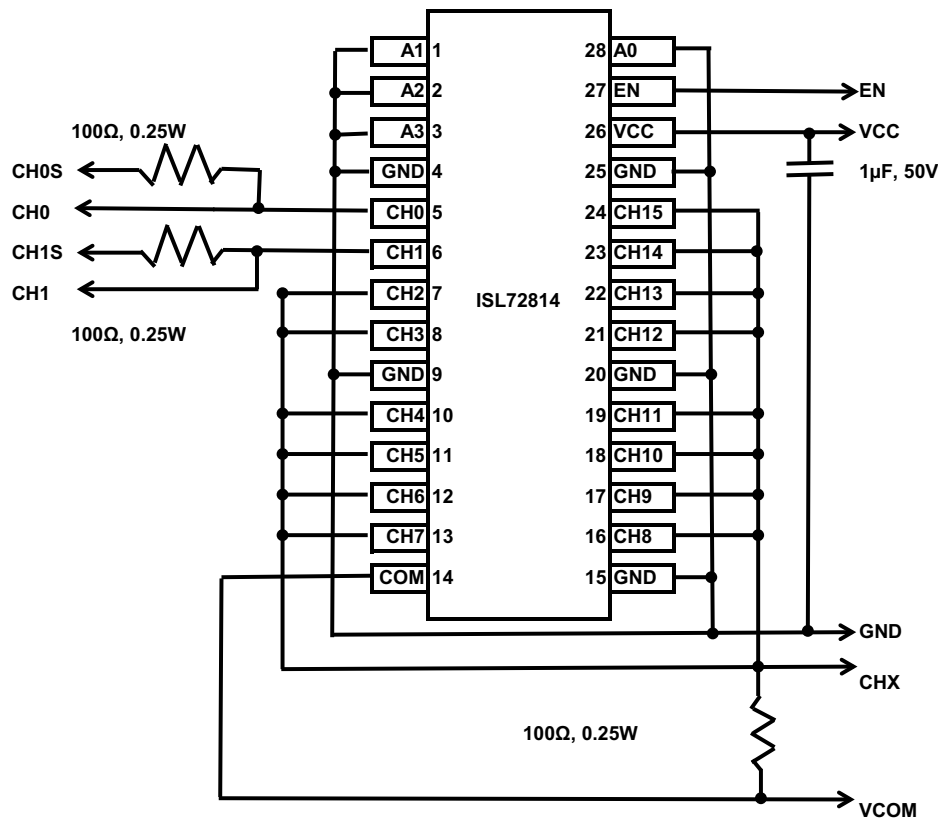

Figure 1. Schematic of the SEE testing arrangement for the ISL72814SEH.

For damaging single events (such as SEB) five parameters were measured before and after irradiation to look for changes indicative of damage. The logic supply current,  $I_{CC}$ , was measured at  $V_{CC} = 15\text{V}$  for both enabled

(EN = 15V) and disabled (EN = GND) conditions. The CH0 voltage (measured on CH0S) was measured while CH0 was enabled and forced to 700mA. Finally the CHX current was measured at CHX = 30V for both enabled and disabled states. For the damaging SEE testing thin film heaters were used on the back of the PCB to raise the case temperature of the part to 125°C ±10°C. Failures were determined at 10% changes across irradiation in enabled I<sub>CC</sub> and for the CH0 voltage. The other leakage current parameters were considered failures at a 50% change across irradiation.

For the damaging single events (such as SEB) irradiations the V<sub>CC</sub> supply and EN line were supplied with 15V. A current of 700mA was forced into the addressed CH0. The OFF channel voltages (CH1, CHX) were set to the test voltage in the range of 32V to 42V. The VCOM terminal was left open. The SEB irradiations tested were with normal incidence gold for LET of 86MeV·cm<sup>2</sup>/mg to a fluence of 1x10<sup>7</sup>ion/cm<sup>2</sup> at a flux of approximately 5x10<sup>4</sup>ion/(cm<sup>2</sup>·s).

For SET testing of the disabled part (EN = GND), the logic supply, V<sub>CC</sub>, was tested at 3V and 4.5V to operate the digital logic with the least noise margin. The OFF channel biasing terminals (VCOM, CH0S, and CH1S) were supplied with 34V. All the OFF channels (CH0, CH1, and CHX) were monitored using oscilloscopes set to capture and store events. The oscilloscope triggers were set to ±2V around the nominal 34V so that any event that turned a channel ON to conduct more than 20mA would result in an event capture.

For single event transient (SET) testing of the enabled part (EN = V<sub>CC</sub>), the logic supply, V<sub>CC</sub>, was again tested at 3V and 4.5V. The OFF channels (VCOM and CH1S) were again supplied with 34V. The ON channel, CH0, was forced to carry 500mA. All the OFF channels (CH1 and CHX) were monitored using oscilloscopes set to capture and store events at ±2V transients. The ON channel, CH0, was monitored (CH0S) for the switch voltage and the oscilloscope trigger was set to ±20mV so that any event that changed the 500mA conduction voltage by more than 20mV was captured.

## 2. Test Results

### 2.1 SEB Testing Results at 86M·cm<sup>2</sup>/mg

Damaging SEE testing started by testing a part (DUT1) at channel voltages starting at 32V and proceeding in 2V increments until failure or 42V. Subsequent parts were tested starting at 1V below the last passing voltage for DUT1 and proceeding with 1V increments until failure. The results of this testing are presented in [Table 1](#). Failures, shown in bold, are determined by a 10% change in either enabled I<sub>CC</sub> or the CH0 voltage at 700mA, or they were determined by a 50% change in either the disabled I<sub>CC</sub>, the enabled CHX leakage, or the disabled CHX leakage.

**Table 1. SEB testing results with LET = 86MeV·cm<sup>2</sup>/mg, 125°C case temperature, and V<sub>CC</sub> = 15V. Channel CH0 was conducting 700mA during irradiation. Tests indicating failures are in bold.**

DUT	VCH	I <sub>CC</sub> Enabled (mA) 10%		I <sub>CC</sub> Disabled (μA) 50%		VCH0 700mA (V) 10%		ICHX at 30V Enabled (μA) 50%		ICHX at 30V Disabled (μA) 50%	
		Pre	Delta	Pre	Delta	Pre	Delta	Pre	Delta	Pre	Delta
1	40	6.5	0%	405	-2%	1.226	0%	0.502	12%	0.215	14%
	42	6.5	0%	396	3%	1.228	0%	0.564	11%	0.245	18%
2	43	6.7	0%	575	0%	1.228	0%	0.168	23%	0.085	12%
	44	6.7	0%	577	-2%	1.230	0%	0.206	>5mA	0.095	>5mA
3	42	6.5	0%	392	5%	1.217	0%	0.288	>5mA	0.151	>5mA
4	38	6.9	0%	586	-5%	1.221	0%	0.082	>5mA	0.059	>5mA
5	37	6.5	0%	411	0%	1.214	1%	0.382	6%	0.189	23%
	38	6.5	0%	413	0%	1.223	0%	0.404	62%	0.232	77%
6	35	6.7	0%	563	2%	1.225	0%	0.125	>5mA	0.089	>5mA
7	35	6.3	0%	399	-4%	1.221	0%	0.33	24%	0.19	21%
	36	6.3	0%	385	4%	1.224	0%	0.409	>5mA	0.23	>5mA

Of the six failing parts, the voltages at failure ranged from 35V to 44V. The lowest fail, DUT6 at 35V, was at the first voltage tested on that particular DUT. However, four DUTs (DUT1, DUT2, DUT5, and DUT7) were tested at 35V or greater without failure. The SEB testing results support the conclusion that the ISL72814SEH, biased at  $V_{CC} = 15V$  and OFF channels at 34V, is immune to damaging SEE for irradiation with normal incidence  $LET=86MeV \cdot cm^2/mg$  ions with a case temperature of  $125^{\circ}C \pm 10^{\circ}C$ .

## 2.2 Testing Results for SET

SET testing consisted of running four unique parts at each of the three LET levels (86, 28, and  $20MeV \cdot cm^2/mg$ ) for a total of twelve parts. Each part was tested at four operating conditions bringing the number of irradiation runs to 48. First, the part was disabled (all channels OFF) and tested at  $V_{CC} = 3.0V$  and  $4.5V$ . Next, the part was enabled (addressing CH0) and tested again at the two  $V_{CC}$  levels.

Throughout the SET testing channels CH2 through CH15 were OFF. All 14 of these OFF channels were wired in parallel as CHX with a  $100\Omega$  resistor to VCOM which was biased at 34V. An SET resulting in conduction of any of these 14 channels led to a voltage transient on CHX. The transients were captured and stored by an oscilloscope set to trigger on a 2V transient (20mA). The oscilloscope also captured the voltages on CH1 and CH0 at the same time.

CH1 was also OFF for all SET testing and was biased through a  $100\Omega$  resistor to 34V and CH1 was monitored with another oscilloscope using a 2V trigger on the channel to capture and store the events. Again the other two voltages, CH0 and CHX, were also captured by the oscilloscope at the same time.

Finally, CH0 was monitored for SET. In the case where the part was disabled ( $EN = GND$ ), CH0 was OFF, and it was biased and monitored in a fashion similar to CH1 described above. When the part was enabled ( $EN = V_{CC}$ ), CH0 was ON and had 500mA forced through it. In this case, the voltage CH0S was monitored and captured by an oscilloscope set to trigger at a 20mV deviation from its nominal value. The voltages on CH1 and CHX were also captured by the oscilloscope at the same time.

Review of the SET captures for CHX at  $86MeV \cdot cm^2/mg$  revealed that many triggering events were very short spikes of much less than the 34V bias. Investigation indicated that noise coupling between channels led to triggering such that events were not always originating on the signal monitored for triggering. An example of this situation is represented in [Figure 2 on page 5](#). In this case the triggering was on the CHX (red) signal. However, the waveforms for CH1 were searched for the ten longest events with at least a 30V deviation. Although the ten events in [Figure 2](#) obviously originated on CH1, CHX saw enough disturbance to trigger capture of the events.

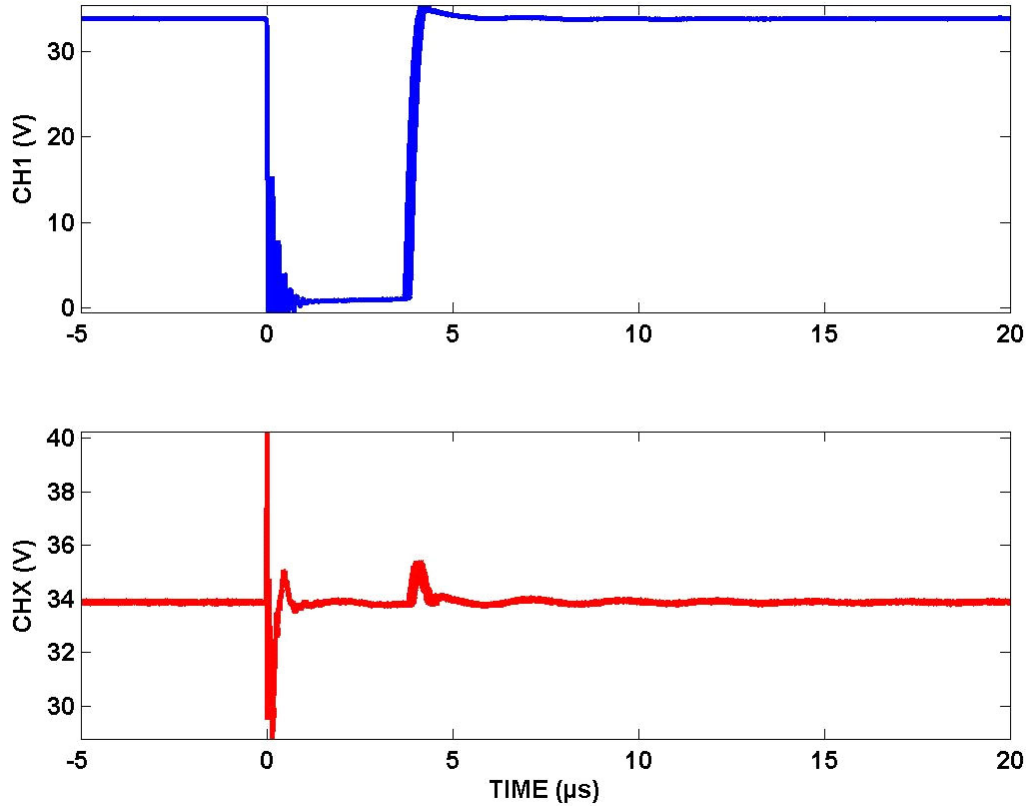

**Figure 2. Composite of the ten longest CH1 transients for disabled DUT8 at  $V_{CC} = 3.0V$  with  $86MeV \cdot cm^2/mg$ . Triggering was done on CHX (red) with CH1 (blue) concurrently captured.**

This noise coupling worked in the reverse direction where an event on CHX would register noise coupling onto CH0 and CH1. In this direction, the more frequent events on CHX (14 channels combined) produced a much higher proportion of noise events on the CH0 and CH1 triggered capture records, greatly complicating the analysis of the CH0 and CH1 data.

In addition to the noise coupling, many short and shallow events were also captured. In an effort to focus attention on the larger and longer SET, the collection of SET captures were filtered to select only those SET that exceeded a 30V deviation (300mA) for more than  $1\mu s$ . This filtering selected approximately 17,000 SET out of the raw 86,000 count, or about one out of five. These limits were arbitrary but provided a data set that highlighted the larger and longer SET that were seen. The change in  $V_{CC}$  voltage did not appreciably impact the SET populations of the filtered CHX data so the SET data for the two voltages were merged: The results are presented on a type of probability plot in [Figure 3 on page 6](#).

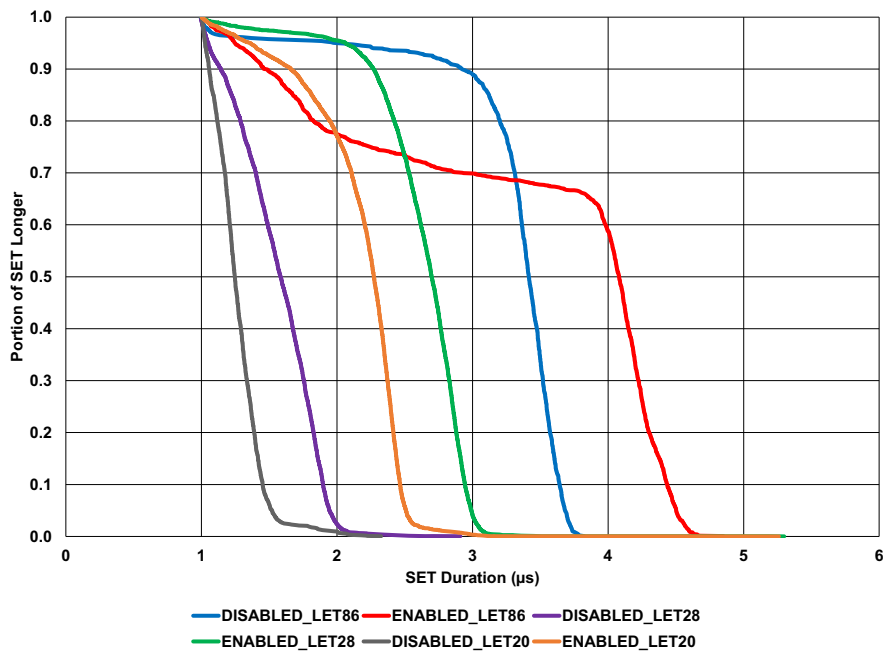

**Figure 3. Probability plot of the CHX SET data filtered for greater than 1µs at a deviation of greater than 30V (300mA through the 100Ω) out of the 34V bias.**

Each of the plotted data sets in [Figure 3](#) is the combination of four parts (unique for each LET), each tested at the two  $V_{CC}$  voltages for a total of eight irradiation runs. For the 86MeV·cm<sup>2</sup>/mg cases the plot data represents a total fluence of  $8.0 \times 10^6$  ion/cm<sup>2</sup> per plot line, while for the two lower LET each plot line represents  $1.6 \times 10^7$  ion/cm<sup>2</sup>. The ultimate SET durations (beyond the 1µs filter limit) show marked dependence on radiation LET. This is an expected result as the energy delivered by the ion is reflected in the length of the SET. However, an unexpected result was that the state of the enable on the part also had a significant impact on the duration of the SET. The enabled state produced longer SET than the disabled state. The longest SET captured was 5.3µs for an enabled part at 28MeV·cm<sup>2</sup>/mg. Inspection of the three longest SET identified them as double events, which explained their rarity.

Cross sections for OFF channel SET based on the results of the single channel CH1 data are summarized in [Table 2](#). The data represents a wide range of cross sections going from a maximum of 4400µm<sup>2</sup> for 86MeV·cm<sup>2</sup>/mg down to a minimum of 500µm<sup>2</sup> for 20MeV·cm<sup>2</sup>/mg. The SET were still relatively common even at 20MeV·cm<sup>2</sup>/mg indicating that an LET threshold for these SET must be at a substantially lower LET.

**Table 2. CH1 SET cross sections for events that exceeded 30V deviation (>300mA) and 1µs duration on parts biased at 34V. The results for four parts at each condition were combined to yield the mean, minimum, and maximum cross sections for those parts.**

LET (MeV·cm <sup>2</sup> /mg)	V <sub>CC</sub> (V)	30V Deviation and 1µs Duration SET Cross Sections (µm <sup>2</sup> )					
		CH1 OFF and Disabled			CH1 OFF and Enabled		
		MEAN	MIN	MAX	MEAN	MIN	MAX
86	3.0	2300	1600	3000	4075	3600	4400
	4.5	2000	1400	2600	2950	1700	3800
28	3.0	1800	1050	2450	3025	2750	3500
	4.5	2063	1850	2550	2163	1800	2500
20	3.0	1075	1000	1250	1913	500	3100
	4.5	1088	850	1300	2300	1750	2550

It was noted earlier that the events on CH1 and CHX seem to be relatively independent with transient edge coupling between the channels. Although that is mostly true, there are some SET that appear to be common to both CH1 and CHX. An example of these common SET is presented in [Figure 4](#) for CH1 and CHX transients that concurrently exhibit deviations of 30V or more. The strong similarity of the seven plotted SET implies a common cause. Such a common cause is likely the transient ESD clamp on the COM node which discharges all the switch channels together if it is tripped. In the sixteen runs at  $86\text{MeV}\cdot\text{cm}^2/\text{mg}$ , the average cross section for the events was  $200\mu\text{m}^2$  with a maximum of  $700\mu\text{m}^2$  (for an enabled part). At  $28\text{MeV}\cdot\text{cm}^2/\text{mg}$ , there were no coincident CH1 and CHX 30V events in sixteen runs at  $2.0\times 10^6\text{ion}/\text{cm}^2$  for each run.

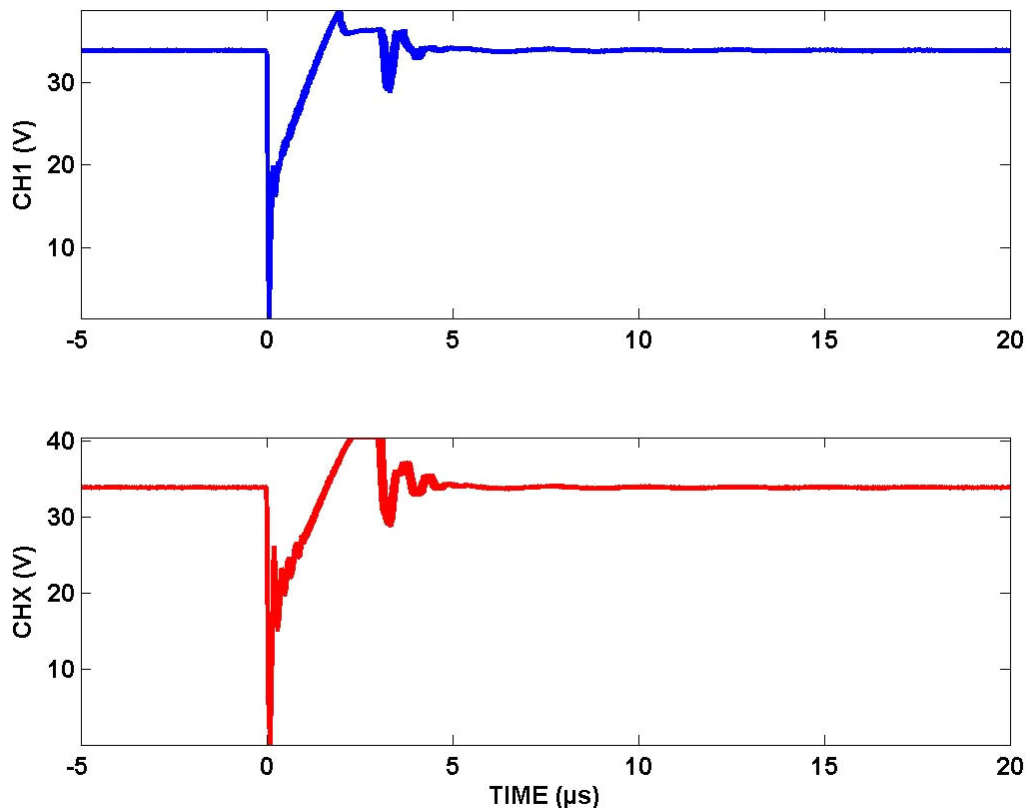

**Figure 4. Composite plot of CH1 (coincidental) and CHX (triggered at 2V) SET where both exceeded 30V deviation on the same capture. This plot is the seven events captured on DUT9 for  $86\text{MeV}\cdot\text{cm}^2/\text{mg}$  irradiation.**

Examination of the captures for the 20mV trigger of the ON channel CH0 revealed that the vast majority of captures were transients of less than 100mV excursion and less than  $1\mu\text{s}$  duration. In fact, most SET appeared to be noise coupling from events occurring on the OFF channels. Consequently, the 20mV triggered CH0 events were filtered to select those events that were greater than +100mV deviation from initial value for more than  $1\mu\text{s}$ . The post processing was applied to the captured data.

A composite plot of the filtered ON channel events from the run of DUT19 at  $V_{CC} = 3.0\text{V}$  and  $20\text{MeV}\cdot\text{cm}^2/\text{mg}$  is presented in [Figure 5 on page 8](#). There are a total of fourteen transients in the plot. All of them have essentially identical beginnings, starting at about 1.07V (the saturation value of the switch with 500mA), then rising to the clipping level of the oscilloscope input at about 1.27V. The rise in voltage indicates the switch is no longer in full conduction and has begun to switch OFF. The current supply providing the 500mA pushes the voltage up toward a 20V compliance level although that is not captured by the oscilloscope. After a period of time from  $25\mu\text{s}$  to  $35\mu\text{s}$  above the 1.27V clipping level, the switch turns ON again and the voltage spikes low to about 0.9V. After the spike, the voltage goes through a recovery transient that includes an overshoot and decay back to the 1.07V switch voltage for 500mA. The recovery transient can hit the oscilloscope clipping level again as seen for the longer transients. The full recovery transients are not captured in the  $45\mu\text{s}$  span of the capture. The post processing

program was tailored to ignore the rebound of the recovery and only measure the event from the trigger (+20mV) to the spike down.

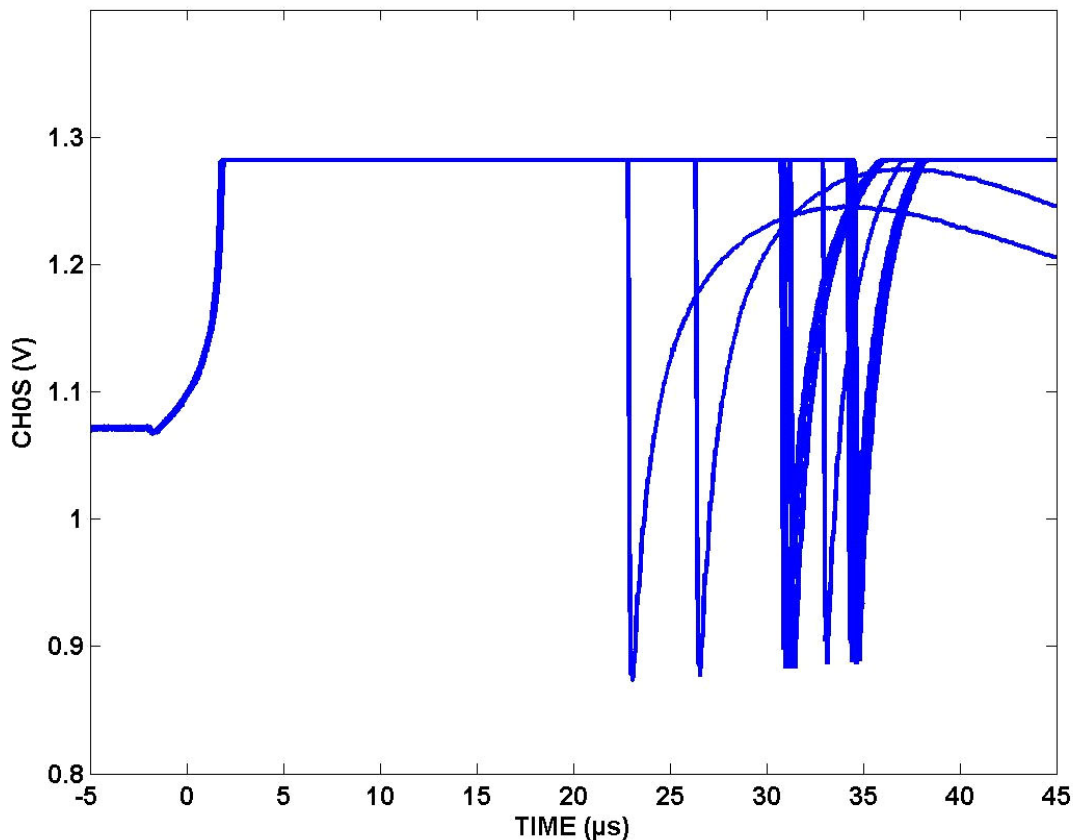

Figure 5. Composite of the 14 ON CH0 transients that exceeded 100mV for more than 1µs for DUT19 run at 20MeV·cm<sup>2</sup>/mg with V<sub>CC</sub> = 3.0V.

The filtered ON CH0 resulted in a total of 578 CH0 ON events to the +100mV deviation and greater than 1µs duration logged for all of the SET testing. The SET counts per irradiation run were widely disparate with a minimum of 1 event in 1.0x10<sup>6</sup>ion/cm<sup>2</sup> (for DUT8 and DUT10 at V<sub>CC</sub> = 4.5V with 86MeV·cm<sup>2</sup>/mg) and a maximum of 98 in 2.0x10<sup>6</sup>ion/cm<sup>2</sup> (for DUT14 at V<sub>CC</sub> = 3.0 with 28MeV·cm<sup>2</sup>/mg). The minimum cross section was then 100µm<sup>2</sup>, and the maximum cross section was 4900µm<sup>2</sup>. The lengths of the SET were slightly dependent on LET. At 86MeV·cm<sup>2</sup>/mg the maximum SET duration (beyond 100mV deviation) was 39.2µs, while at 20MeV·cm<sup>2</sup>/mg the maximum duration was 34.5µs.

### 3. Discussion and Conclusions

Single Event Burnout (SEB) testing supports the conclusion that the ISL72814SEH can survive environments with normal incidence 86MeV·cm<sup>2</sup>/mg ions to 1x10<sup>7</sup>ion/cm<sup>2</sup> at biases of V<sub>CC</sub> = 15V and switch blocking of 34V while at 125°C ±10°C case temperature. There was some variability in the failure voltage, from 35V up to 44V. The lowest failure recorded was 35V. Four units passed SEB testing at 34V or greater, while one unit failed at 35V without being tested at a lower voltage.

Single Event Transient (SET) testing revealed OFF channel conduction events up to 340mA (34V across the 100Ω resistor). SET of at least 1µs duration beyond a 30V deviation (300mA) registered a maximum duration of 5.3µs and maximum cross section of 4400µm<sup>2</sup> at 86MeV·cm<sup>2</sup>/mg. At 20MeV·cm<sup>2</sup>/mg, the maximum cross section recorded was 3100µm<sup>2</sup>. No threshold LET was established for the OFF channel conduction events of 1µs and 30V (300mA) deviation.

SETs occurring for an ON channel (CH0) cause loss of switch conduction for the duration of such transients. The transients were defined as more than 1 $\mu$ s duration at a 500mA conduction voltage of +100mV deviation above the switch nominal saturation voltage at the current. Transients up to 39 $\mu$ s long were recorded in the SET testing for 86MeV $\cdot$ cm<sup>2</sup>/mg. No ON channel threshold LET was established as the events occurred down to 20MeV $\cdot$ cm<sup>2</sup>/mg. The events recorded a maximum cross section of 4900 $\mu$ m<sup>2</sup> at 28MeV $\cdot$ cm<sup>2</sup>/mg.

The SET disturbances on the channels lasting tens of microseconds make the use of the ISL72814SEH for fast response loads contraindicated. However, with the SET durations limited to 40 $\mu$ s or less, slow response inductive loads such as relays should not be adversely impacted by the SET.

## 4. Revision History

Rev.	Date	Description
1.00	Jan 8, 2019	Initial release

## Notice

1. Descriptions of circuits, software and other related information in this document are provided only to illustrate the operation of semiconductor products and application examples. You are fully responsible for the incorporation or any other use of the circuits, software, and information in the design of your product or system. Renesas Electronics disclaims any and all liability for any losses and damages incurred by you or third parties arising from the use of these circuits, software, or information.
  2. Renesas Electronics hereby expressly disclaims any warranties against and liability for infringement or any other claims involving patents, copyrights, or other intellectual property rights of third parties, by or arising from the use of Renesas Electronics products or technical information described in this document, including but not limited to, the product data, drawings, charts, programs, algorithms, and application examples.
  3. No license, express, implied or otherwise, is granted hereby under any patents, copyrights or other intellectual property rights of Renesas Electronics or others.
  4. You shall not alter, modify, copy, or reverse engineer any Renesas Electronics product, whether in whole or in part. Renesas Electronics disclaims any and all liability for any losses or damages incurred by you or third parties arising from such alteration, modification, copying or reverse engineering.
  5. Renesas Electronics products are classified according to the following two quality grades: "Standard" and "High Quality". The intended applications for each Renesas Electronics product depends on the product's quality grade, as indicated below.  
"Standard": Computers; office equipment; communications equipment; test and measurement equipment; audio and visual equipment; home electronic appliances; machine tools; personal electronic equipment; industrial robots; etc.  
"High Quality": Transportation equipment (automobiles, trains, ships, etc.); traffic control (traffic lights); large-scale communication equipment; key financial terminal systems; safety control equipment; etc.  
Unless expressly designated as a high reliability product or a product for harsh environments in a Renesas Electronics data sheet or other Renesas Electronics document, Renesas Electronics products are not intended or authorized for use in products or systems that may pose a direct threat to human life or bodily injury (artificial life support devices or systems; surgical implantations; etc.), or may cause serious property damage (space system; undersea repeaters; nuclear power control systems; aircraft control systems; key plant systems; military equipment; etc.). Renesas Electronics disclaims any and all liability for any damages or losses incurred by you or any third parties arising from the use of any Renesas Electronics product that is inconsistent with any Renesas Electronics data sheet, user's manual or other Renesas Electronics document.
  6. When using Renesas Electronics products, refer to the latest product information (data sheets, user's manuals, application notes, "General Notes for Handling and Using Semiconductor Devices" in the reliability handbook, etc.), and ensure that usage conditions are within the ranges specified by Renesas Electronics with respect to maximum ratings, operating power supply voltage range, heat dissipation characteristics, installation, etc. Renesas Electronics disclaims any and all liability for any malfunctions, failure or accident arising out of the use of Renesas Electronics products outside of such specified ranges.
  7. Although Renesas Electronics endeavors to improve the quality and reliability of Renesas Electronics products, semiconductor products have specific characteristics, such as the occurrence of failure at a certain rate and malfunctions under certain use conditions. Unless designated as a high reliability product or a product for harsh environments in a Renesas Electronics data sheet or other Renesas Electronics document, Renesas Electronics products are not subject to radiation resistance design. You are responsible for implementing safety measures to guard against the possibility of bodily injury, injury or damage caused by fire, and/or danger to the public in the event of a failure or malfunction of Renesas Electronics products, such as safety design for hardware and software, including but not limited to redundancy, fire control and malfunction prevention, appropriate treatment for aging degradation or any other appropriate measures. Because the evaluation of microcomputer software alone is very difficult and impractical, you are responsible for evaluating the safety of the final products or systems manufactured by you.
  8. Please contact a Renesas Electronics sales office for details as to environmental matters such as the environmental compatibility of each Renesas Electronics product. You are responsible for carefully and sufficiently investigating applicable laws and regulations that regulate the inclusion or use of controlled substances, including without limitation, the EU RoHS Directive, and using Renesas Electronics products in compliance with all these applicable laws and regulations. Renesas Electronics disclaims any and all liability for damages or losses occurring as a result of your noncompliance with applicable laws and regulations.
  9. Renesas Electronics products and technologies shall not be used for or incorporated into any products or systems whose manufacture, use, or sale is prohibited under any applicable domestic or foreign laws or regulations. You shall comply with any applicable export control laws and regulations promulgated and administered by the governments of any countries asserting jurisdiction over the parties or transactions.
  10. It is the responsibility of the buyer or distributor of Renesas Electronics products, or any other party who distributes, disposes of, or otherwise sells or transfers the product to a third party, to notify such third party in advance of the contents and conditions set forth in this document.
  11. This document shall not be reprinted, reproduced or duplicated in any form, in whole or in part, without prior written consent of Renesas Electronics.
  12. Please contact a Renesas Electronics sales office if you have any questions regarding the information contained in this document or Renesas Electronics products.
- (Note 1) "Renesas Electronics" as used in this document means Renesas Electronics Corporation and also includes its directly or indirectly controlled subsidiaries.  
(Note 2) "Renesas Electronics product(s)" means any product developed or manufactured by or for Renesas Electronics.

(Rev.4.0-1 November 2017)



### SALES OFFICES

Renesas Electronics Corporation

<http://www.renesas.com>

Refer to "<http://www.renesas.com/>" for the latest and detailed information.

#### Renesas Electronics Corporation

TOYOSU FORESIA, 3-2-24 Toyosu, Koto-ku, Tokyo 135-0061, Japan

#### Renesas Electronics America Inc.

1001 Murphy Ranch Road, Milpitas, CA 95035, U.S.A.  
Tel: +1-408-432-8888, Fax: +1-408-434-5351

#### Renesas Electronics Canada Limited

9251 Yonge Street, Suite 8309 Richmond Hill, Ontario Canada L4C 9T3  
Tel: +1-905-237-2004

#### Renesas Electronics Europe Limited

Dukes Meadow, Millboard Road, Bourne End, Buckinghamshire, SL8 5FH, U.K  
Tel: +44-1628-651-700

#### Renesas Electronics Europe GmbH

Arcadiastrasse 10, 40472 Düsseldorf, Germany  
Tel: +49-211-6503-0, Fax: +49-211-6503-1327

#### Renesas Electronics (China) Co., Ltd.

Room 1709 Quantum Plaza, No.27 ZhichunLu, Haidian District, Beijing, 100191 P. R. China  
Tel: +86-10-8235-1155, Fax: +86-10-8235-7679

#### Renesas Electronics (Shanghai) Co., Ltd.

Unit 301, Tower A, Central Towers, 555 Langao Road, Putuo District, Shanghai, 200333 P. R. China  
Tel: +86-21-2226-0888, Fax: +86-21-2226-0999

#### Renesas Electronics Hong Kong Limited

Unit 1601-1611, 16/F., Tower 2, Grand Century Place, 193 Prince Edward Road West, Mongkok, Kowloon, Hong Kong  
Tel: +852-2265-6688, Fax: +852 2886-9022

#### Renesas Electronics Taiwan Co., Ltd.

13F, No. 363, Fu Shing North Road, Taipei 10543, Taiwan  
Tel: +886-2-8175-9600, Fax: +886 2-8175-9670

#### Renesas Electronics Singapore Pte. Ltd.

80 Bendemeer Road, Unit #06-02 Hyflux Innovation Centre, Singapore 339949  
Tel: +65-6213-0200, Fax: +65-6213-0300

#### Renesas Electronics Malaysia Sdn.Bhd.

Unit 1207, Block B, Menara Amcorp, Amcorp Trade Centre, No. 18, Jln Persiaran Barat, 46050 Petaling Jaya, Selangor Darul Ehsan, Malaysia  
Tel: +60-3-7955-9390, Fax: +60-3-7955-9510

#### Renesas Electronics India Pvt. Ltd.

No.777C, 100 Feet Road, HAL 2nd Stage, Indiranagar, Bangalore 560 038, India  
Tel: +91-80-67208700, Fax: +91-80-67208777

#### Renesas Electronics Korea Co., Ltd.

17F, KAMCO Yangjae Tower, 262, Gangnam-daero, Gangnam-gu, Seoul, 06265 Korea  
Tel: +82-2-558-3737, Fax: +82-2-558-5338