

---

## EBC10296

SSR GaN-SiP Design, GaN Ecosystem, 65W PD3.2

---

## Introduction

This document explains how to set up the EBC10296 evaluation board.

## Target Device

EBC10296 – 65W PD3.2 design

## Notice

The EBC10296 evaluation board is powered by AC main voltage. When powered, the board generates non-insulated high voltages that may produce electrical shock, burn, and/or fire hazards, resulting in risk of property damage, personal injury, and/or death.

When the board is powered, never touch it or its electrical circuits because they may cause electrical shock.

## Contents

1. Overview.....	2
2. Equipment and Setup.....	2
2.1 Recommended Equipment .....	2
2.2 Setup and Operation.....	3
3. System Power Off .....	3
4. Ordering Information .....	4
5. Revision History .....	4

# 1. Overview

The EBC10296 board supports the PD3.2 protocol for various voltage levels according to the setting in the voltage adjustable USB PD trigger.

The USB PD tester can trigger the different PD protocols (20V 3.25A, 15V 3.25A, 9V 3.25A, and 5V 3.25A).

The current and power can be adjusted by electric load.

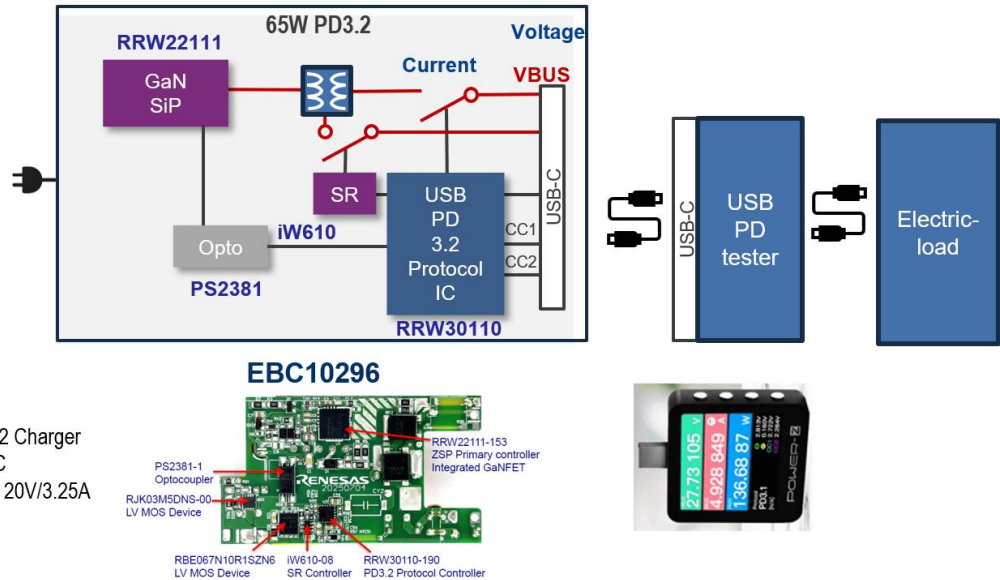

- EBC 10296: 65W USB-C PD 3.2 Charger
- AC input range: 90-264 VAC
  - DC output from 5V/3.25A to 20V/3.25A

Figure 1. EBC10296 Evaluation Board

# 2. Equipment and Setup

## 2.1 Recommended Equipment

- An AC power supply capable of generating AC voltage from 90V to 264V at 60Hz/50Hz, with at least 2A output current capability.
- An E-load or a load resistor box with an adjustable value of 6.2Ω and up, or an electronic load that can emulate a resistor load or current load up to 3.25A for 20V output. A load resistor box with an adjustable value of 1.5Ω and up or an electronic load that can emulate a resistor load or current load up to 3.25A for 5V output.
- Multimeters to measure the output voltage and current
- Power meter to measure the AC input power
- Power-Z tester: For more information about the tester, visit [ChargerLAB POWER-Z KM003C - POWER-Z](https://www.chargerlab.com/power-z-km003c-power-z/)

## 2.2 Setup and Operation

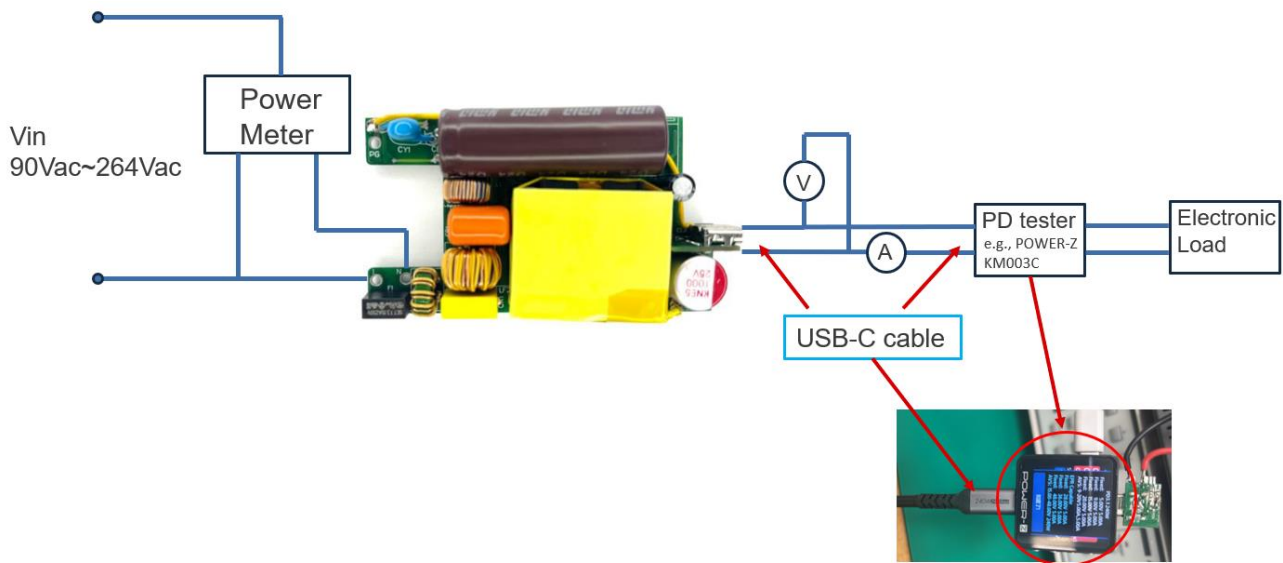

Figure 2. EBC10296 Connection Diagram

1. Program the AC power supply with a voltage between 90V and 264V at the corresponding frequency of 60Hz or 50Hz.
2. While the AC power supply is off, connect the output cables of the AC power supply to the L and N terminal of the EBC10296 board. An optional power meter can be added in between the AC power supply output and input of the board.
3. Connect the EBC10296 board to the PD tester (for example, Power-Z KM003C) using a 65W USB-C cable, and the corresponding load to the output terminal of PD tester.
4. Connect a voltage meter to VOUT and GND, and connect a current meter between the board outputs and the load.
5. Turn on the AC power supply. When a successful connection is established, POWER-Z KM003C performs a PDO discovery, and the solution kit is pre-configured with corresponding PDOs.

## 3. System Power Off

Before powering off the system, read the following important operational note.

*Important:* Due to large capacitors in the EBC10296 board, the board requires a long time to power off. Do not take out the module from the box and touch it.

## 4. Ordering Information

Part Number	Description
EBC10296	EBC10296 Evaluation Board

## 5. Revision History

Revision	Date	Description
1.00	Mar 13, 2026	Initial release.