

Rapid Charge™ AC/DC Digital Quasi-Resonant PWM Controller

1 Description

The iW1780 is a high performance AC/DC power supply controller for rapid charge that uses digital control technology to build peak-current mode PWM flyback power supplies. The device operates in quasi-resonant mode to provide high efficiency and a number of key built-in protection features. The iW1780 can achieve tight multi-level constant voltage and multi-level constant current regulation without a traditional secondary-feedback circuit. It also eliminates the need for loop compensation components while maintaining stability over all operating conditions.



The iW1780 is optimized to work with Dialog's secondary-side controller for Qualcomm® Quick Charge™ 2.0 (QC2.0) interface and secondary-primary communication, iW626, to achieve fast and smooth voltage transition upon request by portable devices (PD). When paired with the iW626, the iW1780 eliminates the discrete decoders on the primary side, minimizes the external component count and simplifies system designs. The iW626 can communicate with the iW1780 through one optocoupler for all the necessary rapid charge information including output voltage requests, output current limits, output voltage undershoot and output over-voltage.

Dialog's innovative proprietary technology ensures that power supplies designed with the iW1780 and iW626 can provide 5V/9V/12V output voltage configuration, with user-selected various output current limit combinations. Furthermore, the chipset can achieve <10mW no-load power consumption at 5V2A output setting and fast dynamic load response in typical AC/DC HVDCP adapter designs.

2 Features

- Supports rapid charge technologies such as Qualcomm® Quick Charge™ 2.0 (QC2.0) technology to provide 5V/9V/12V with user-selected various output current limit combinations
- Proprietary secondary-to-primary digital communication and built-in decoder eliminate discrete decoder and significantly simplify system design
- Single optocoupler for all the rapid charge information: output voltage request, output current limit, output voltage undershoot, and over-voltage protection
- Tight multi-level constant-voltage and multi-level constant-current regulation with primary-side feedback and control
- Ultra-low no-load power consumption with lowest system cost (< 10mW at 230V_{AC} with typical 5V2A setting using Schottky diode rectifier; < 20mW at 230V_{AC} with typical 5V2A setting using synchronous rectifier)
- Fast dynamic load response (DLR) with secondary-side load transient detection
- Proprietary optimized line/load adaptive maximum constant frequency PWM switching with quasi-resonant operation achieves best size, efficiency, and common mode noise
- Multi-mode PWM/PFM control improves efficiency at various load conditions
- User-configurable 5-level cable drop compensation independent of output voltage
- **EZ-EMI**® design enhances manufacturability
- Built-in single-point fault protections against output short-circuit including soft short and half short, output over-voltage, and output over-current
- **SmartDefender**™ smart hiccup technology helps address issues of soft shorts in cables and connectors by effectively reducing the average output power at fault conditions without latch
- User-configurable external shutdown control
- No audible noise over entire operating range

3 Applications

- Rapid-charging AC/DC adapters for smart phones, tablets and other portable devices (5V-12V, 1A-3A).



Rapid Charge™ AC/DC Digital Quasi-Resonant PWM Controller

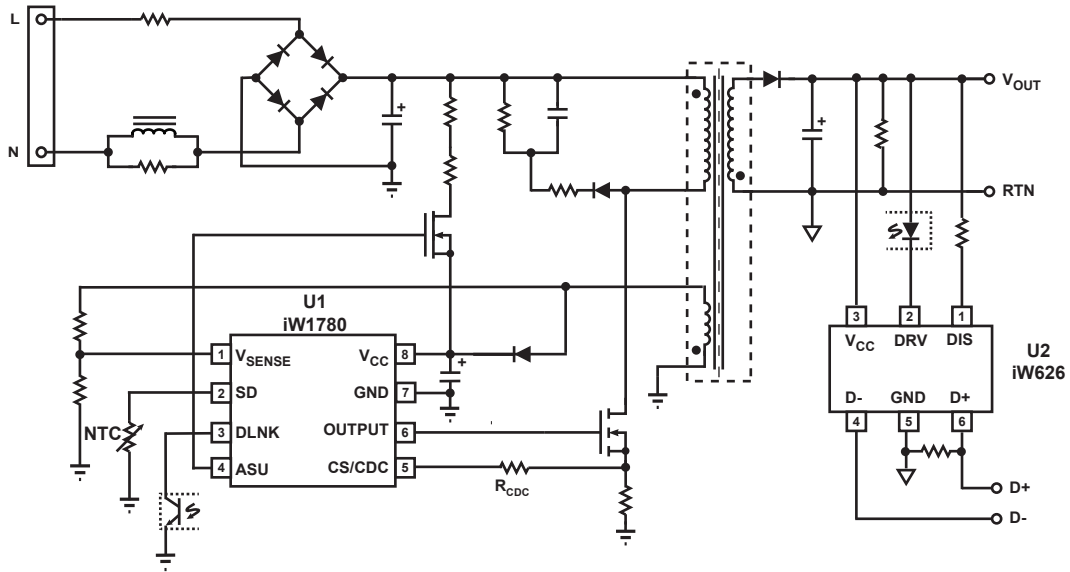

Figure 3.1 : iW1780 Typical Application Circuit for Multi-Level Output Voltage and Current (Using iW626 as Secondary-Side Controller for QC2.0. Achieving < 10mW No-Load Power Consumption.)

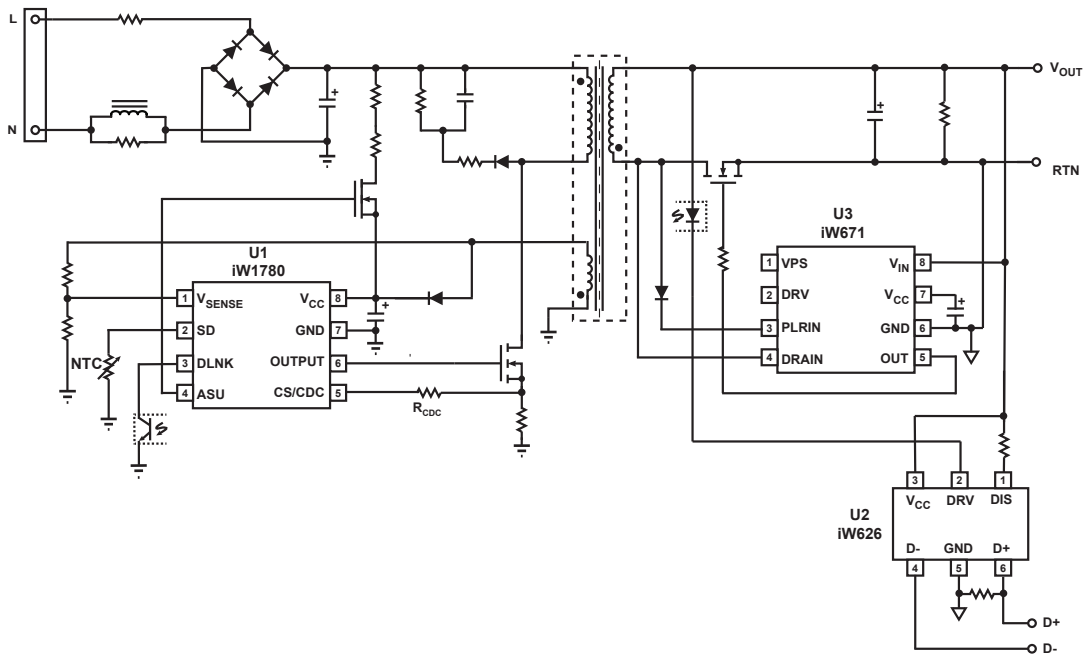

Figure 3.2 : iW1780 Typical Application Circuit for Multi-Level Output Voltage and Current (Using iW626 as Secondary-Side Controller for QC2.0 and iW671 as Synchronous Rectifier Controller. Achieving < 20mW No-Load Power Consumption.)

Rapid Charge™ AC/DC Digital Quasi-Resonant PWM Controller

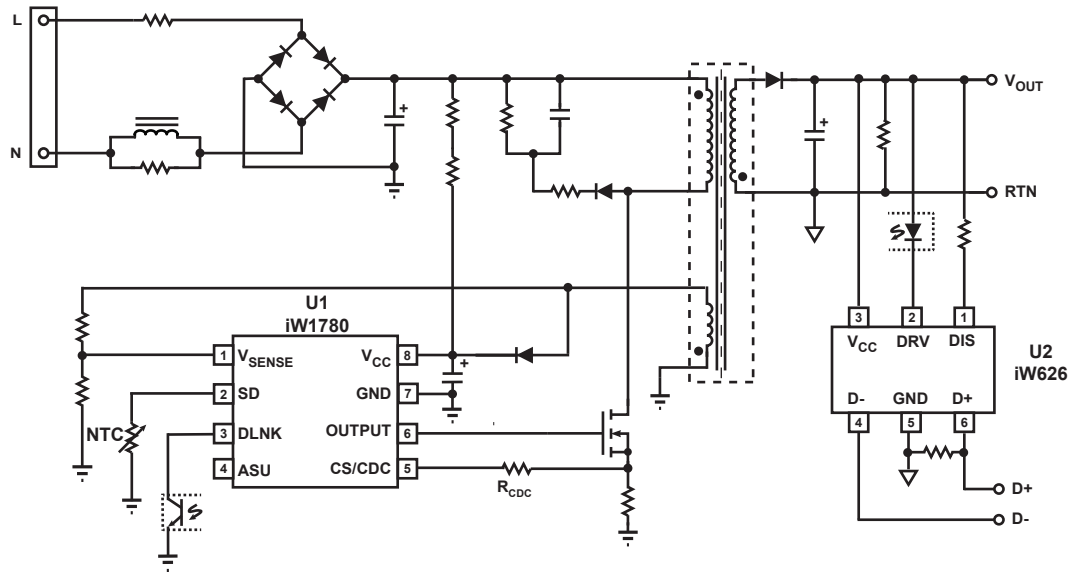

Figure 3.3 : iW1780 Typical Low Cost Application Circuit for Multi-Level Output Voltage and Current (Using iW626 as Secondary-Side Controller for QC2.0. Achieving < 50mW No-Load Power Consumption Without Using Active Start-up Device.)

4 Pinout Description

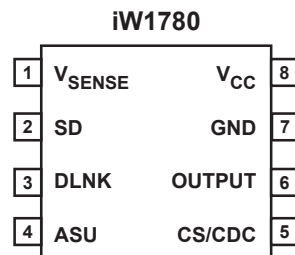

Figure 4.1 : 8-Lead SOIC Package

Pin Number	Pin Name	Type	Pin Description
1	V _{SENSE}	Analog Input	Auxiliary voltage sense. Used for primary-side regulation.
2	SD	Analog Input	External shutdown control. Can be configured for external over-temperature protection (OTP) by connecting an NTC resistor from this pin to Ground.
3	DLNK	Analog Input	Digital communication link signal. Used for secondary-side to primary-side communication for all rapid charge information, which includes output voltage requests, output current limits, output voltage undershoot, and over-voltage protection.
4	ASU	Output	Control signal. Used for active start-up device (BJT or depletion mode N-FET).
5	CS/CDC	Analog Input	Primary-side current sense and external cable drop compensation (CDC). Used for cycle-by-cycle peak-current control and limit in primary-side CV/CC regulation. Also used for CDC configuration.
6	OUTPUT	Output	Gate drive for external MOSFET switch.
7	GND	Ground	Ground.
8	V _{CC}	Power Input	IC power supply.

Rapid Charge™ AC/DC Digital Quasi-Resonant PWM Controller

5 Absolute Maximum Ratings

Absolute maximum ratings are the parameter values or ranges which can cause permanent damage if exceeded.

Parameter	Symbol	Value	Units
DC supply voltage range (pin 8, $I_{CC} = 20\text{mA max}$)	V_{CC}	-0.3 to 25.0	V
Continuous DC supply current at V_{CC} pin ($V_{CC} = 15\text{V}$)	I_{CC}	20	mA
ASU output (pin 4)		-0.3 to 19.0	V
OUTPUT (pin 6)		-0.3 to 20.0	V
V_{SENSE} input (pin 1, $I_{V_{sense}} \leq 10\text{mA}$)		-0.7 to 10.0	V
CS/CDC input (pin 5)		-0.3 to 4.0	V
SD (pin 2)		-0.3 to 4.0	V
DLNK (pin 3)		-0.3 to 4.0	V
Maximum junction temperature	T_{JMAX}	150	°C
Operating junction temperature	T_{JOPT}	-40 to 150	°C
Storage temperature	T_{STG}	-65 to 150	°C
Thermal resistance junction-to-ambient	θ_{JA}	160	°C/W
ESD rating per JEDEC JESD22-A114		$\pm 2,000$	V
Latch-up test per JESD78A		± 100	mA

Rapid Charge™ AC/DC Digital Quasi-Resonant PWM Controller

6 Physical Dimensions

8-Lead Small Outline (SOIC) Package

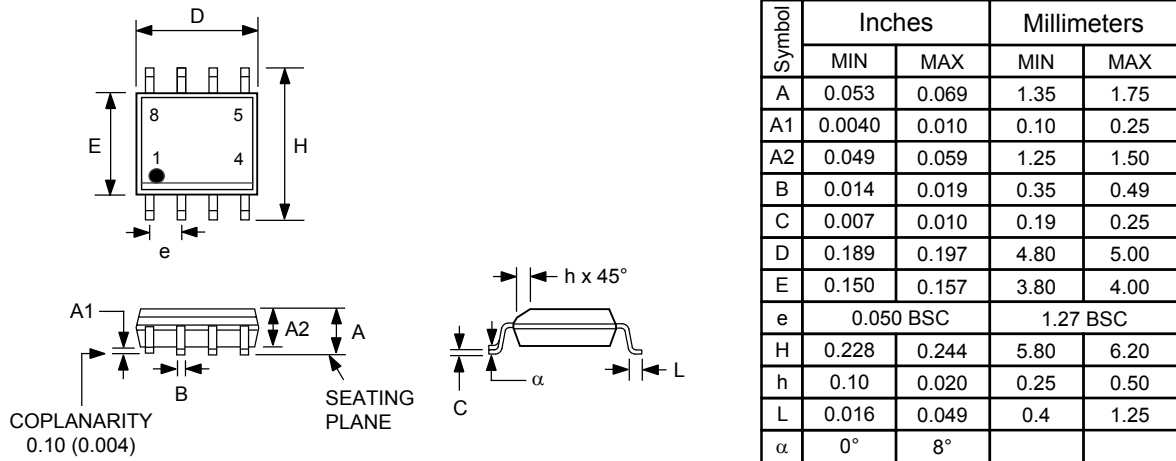

Compliant to JEDEC Standard MS12F

Controlling dimensions are in inches; millimeter dimensions are for reference only

This product is RoHS compliant and Halide free.

Soldering Temperature Resistance:

[a] Package is IPC/JEDEC Std 020D moisture sensitivity level 1

[b] Package exceeds JEDEC Std No. 22-A111 for solder immersion resistance; package can withstand 10 s immersion < 260°C

Dimension D does not include mold flash, protrusions or gate burrs. Mold flash, protrusions or gate burrs shall not exceed 0.15 mm per end. Dimension E1 does not include interlead flash or protrusion. Interlead flash or protrusion shall not exceed 0.25 mm per side.

The package top may be smaller than the package bottom. Dimensions D and E1 are determined at the outermost extremes of the plastic body exclusive of mold flash, tie bar burrs, gate burrs and interlead flash, but including any mismatch between the top and bottom of the plastic body.

Figure 6.1 : 8-Lead Small Outline (SOIC) Package

Rapid Charge™ AC/DC Digital Quasi-Resonant PWM Controller

7 Ordering Information

Part no.	Options	Package	Description
iW1780-00	For applications with same CC limit for 5V/9V, 3V CC shutdown voltage ¹ for 5V V _{OUT} , no smart hiccup, paired with iW626-02/04	SOIC-8	Tape & Reel ²
iW1780-01	For applications with different CC limits for 5V/9V, 3V CC shutdown voltage ¹ for 5V V _{OUT} , smart hiccup with 2/8 duty cycle, paired with iW626-00	SOIC-8	Tape & Reel ²
iW1780-03	For applications with different CC limits for 5V/9V, 3V CC shutdown voltage ¹ for 5V V _{OUT} , smart hiccup with 2/8 duty cycle, the regulation voltage for 9V/12V V _{OUT} is approximately 2% lower compared with iW1780-01 with the same external circuit, paired with iW626-00	SOIC-8	Tape & Reel ²
iW1780-04	For applications with same CC limits for 5V/9V, 2.7V CC shutdown voltage ¹ for all V _{OUT} , no smart hiccup, paired with iW626-02/04	SOIC-8	Tape & Reel ²
iW1780-06	For applications with same CC limits for 5V/9V, no CC operation, no smart hiccup, paired with iW626-02/04	SOIC-8	Tape & Reel ²
iW1780-07	For applications with same CC limits for 5V/9V, 3.5V CC shutdown voltage ¹ for 5V V _{OUT} , no smart hiccup, paired with iW626-02/04	SOIC-8	Tape & Reel ²
iW1780-09	For applications with same CC limits for 5V/9V, 3V CC shutdown voltage ¹ for 5V V _{OUT} , smart hiccup with 2/8 duty cycle, paired with iW626-02/04	SOIC-8	Tape & Reel ²
iW1780-23	For applications with pre-determined CC limit coefficients of k=0.411/0.347/0.411 for 5V/9V/12V, 3V CC shutdown voltage for 5V V _{OUT} ¹ , smart hiccup with 2/8 duty cycle, same CV regulation as iW1780-03, paired with iW626-02/04	SOIC-8	Tape & Reel ²
iW1780-30	For applications with same CC limit for 5V/9V, 3V CC shutdown voltage ¹ for 5V V _{OUT} , no smart hiccup, paired with iW626-02/04, OVP latch for V _{SENSE} -based OVP and secondary-side-based OVP	SOIC-8	Tape & Reel ²

Note 1: Unless specified, the default CC shutdown voltages are 6.5V for 9V V_{OUT} and 10V for 12V V_{OUT}.

Note 2: Tape & Reel packing quantity is 2,500/reel. Minimum ordering quantity is 2,500.

Rapid Charge™ AC/DC Digital Quasi-Resonant PWM Controller

IMPORTANT NOTICE AND DISCLAIMER

RENESAS ELECTRONICS CORPORATION AND ITS SUBSIDIARIES (“RENESAS”) PROVIDES TECHNICAL SPECIFICATIONS AND RELIABILITY DATA (INCLUDING DATASHEETS), DESIGN RESOURCES (INCLUDING REFERENCE DESIGNS), APPLICATION OR OTHER DESIGN ADVICE, WEB TOOLS, SAFETY INFORMATION, AND OTHER RESOURCES “AS IS” AND WITH ALL FAULTS, AND DISCLAIMS ALL WARRANTIES, EXPRESS OR IMPLIED, INCLUDING, WITHOUT LIMITATION, ANY IMPLIED WARRANTIES OF MERCHANTABILITY, FITNESS FOR A PARTICULAR PURPOSE, OR NON-INFRINGEMENT OF THIRD PARTY INTELLECTUAL PROPERTY RIGHTS.

These resources are intended for developers skilled in the art designing with Renesas products. You are solely responsible for (1) selecting the appropriate products for your application, (2) designing, validating, and testing your application, and (3) ensuring your application meets applicable standards, and any other safety, security, or other requirements. These resources are subject to change without notice. Renesas grants you permission to use these resources only for development of an application that uses Renesas products. Other reproduction or use of these resources is strictly prohibited. No license is granted to any other Renesas intellectual property or to any third party intellectual property. Renesas disclaims responsibility for, and you will fully indemnify Renesas and its representatives against, any claims, damages, costs, losses, or liabilities arising out of your use of these resources. Renesas’ products are provided only subject to Renesas’ Terms and Conditions of Sale or other applicable terms agreed to in writing. No use of any Renesas resources expands or otherwise alters any applicable warranties or warranty disclaimers for these products.

© 2022 Renesas Electronics Corporation. All rights reserved.

RoHS Compliance

Dialog Semiconductor’s suppliers certify that its products are in compliance with the requirements of Directive 2011/65/EU of the European Parliament on the restriction of the use of certain hazardous substances in electrical and electronic equipment. RoHS certificates from our suppliers are available on request.

(Rev.1.0 Mar 2020)

Corporate Headquarters

TOYOSU FORESIA, 3-2-24 Toyosu
Koto-ku, Tokyo 135-0061, Japan
www.renesas.com

Contact Information

For further information on a product, technology, the most up-to-date version of a document, or your nearest sales office, please visit:
www.renesas.com/contact/

Trademarks

Renesas and the Renesas logo are trademarks of Renesas Electronics Corporation. All trademarks and registered trademarks are the property of their respective owners.