

FEATURES

- Compensates for cable and PCB trace attenuation and ISI jitter
- Programmable receiver equalization up to 24dB
- Programmable transmitter swing and de-emphasis
- Recovers data stream even when the differential signal eye is completely closed due to trace attenuation and ISI jitter
- Configurable via external pins
- No external bias resistors or reference clocks required
- Low operating power
- Available in a 20-pin QFN package (4.0 x 4.0mm, 0.5mm pitch)

BENEFITS

- Extends maximum cable length to over 8 meters and trace length over 48 inches
- Minimizes BER

APPLICATIONS

- Supports differential signaling to 6.25Gbps
- Systems:
 - Servers, Telecommunications, Storage, Instrumentation, Active Cabling

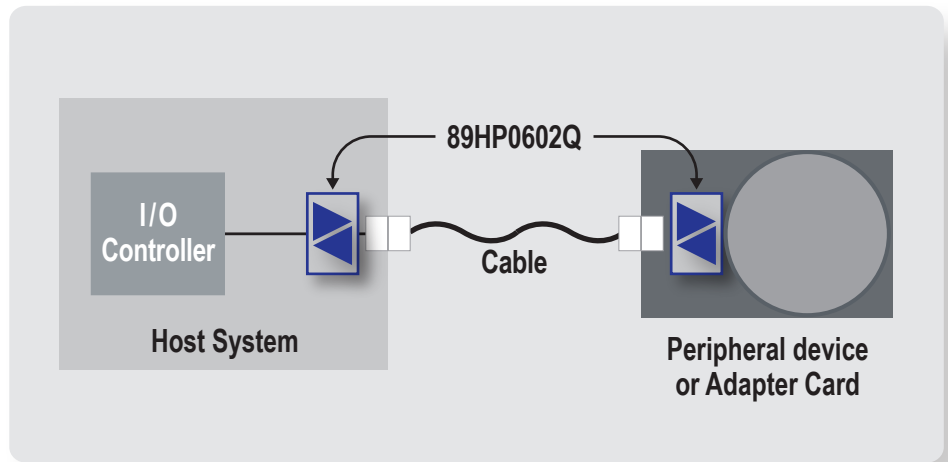

Device Overview

The IDT 89HP0602Q is a 6.25Gbps Repeater featuring IDT EyeBoost™ technology that compensates for cable and board trace attenuations and ISI jitter, thereby extending connection reach. The device is optimized for differential high speed serial data streams and contains two data channels, each able to process 6.25Gbps transmission rates. Each channel consists of an input equalizer and amplifier, signal detection with glitch filter, as well as programmable output swing and de-emphasis. Allowing for application specific optimization, the 89HP0602Q, with its configurable receiver and transmitter features, is ideal for a variety of applications using a wide combination of cables and board trace materials.

All modes of active data transfer are designed with minimized power consumption. In addition, power is further reduced in the absence of input signals (loss of signal mode).

89HP0602Q Channel Block Diagram (one of two shown)

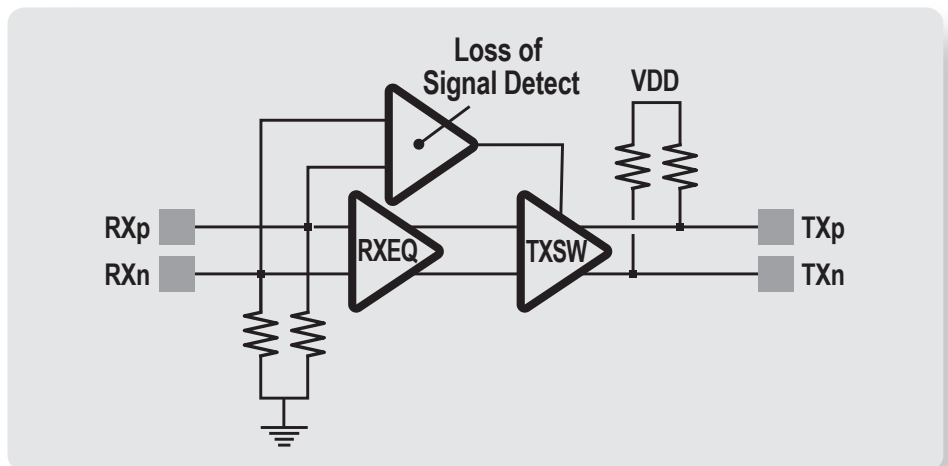

Discover what IDT know-how can do for you: www.IDT.com

DISCLAIMER Integrated Device Technology, Inc. (IDT) and its subsidiaries reserve the right to modify the products and/or specifications described herein at any time and at IDT's sole discretion. All information in this document, including descriptions of product features and performance, is subject to change without notice. Performance specifications and the operating parameters of the described products are determined in the independent state and are not guaranteed to perform the same way when installed in customer products. The information contained herein is provided without representation or warranty of any kind, whether express or implied, including, but not limited to, the suitability of IDT's products for any particular purpose, an implied warranty of merchantability, or non-infringement of the intellectual property rights of others. This document is presented only as a guide and does not convey any license under intellectual property rights of IDT or any third parties. IDT's products are not intended for use in life support systems or similar devices where the failure or malfunction of an IDT product can be reasonably expected to significantly affect the health or safety of users. Anyone using an IDT product in such a manner does so at their own risk, absent an express, written agreement by IDT.
Integrated Device Technology, IDT and the IDT logo are registered trademarks of IDT. Other trademarks and service marks used herein, including protected names, logos and designs, are the property of IDT or their respective third party owners.
© Copyright 2012. All rights reserved.