

RL78 Motor Control

YRMCKITRL78G14 Starter Kit



Renesas Electronics Europe

David Parsons Application Engineering
Industrial Business Group

July 2012

Renesas MCU for 3-phase Motor Control



Control Method

Brushless AC



Vector Control

180°



Sensorless ✓
⇒ 1 or 3 shunts



Sensored ✓
⇒ Hall, encoder...



Brushless DC

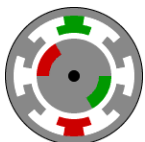

Trapezoidal Control

120°



Sensorless ✓
⇒ Back EMF

Sensored ✓
⇒ Hall, encoder...

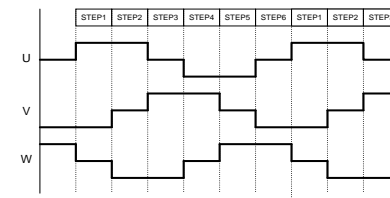

Induction AC



Vector Control

180°



Sensorless ✓
⇒ 1 or 3 shunts

Sensored ✓
⇒ Hall, encoder...



V/f Control

180°



Sensored ✓
⇒ Tacho, Hall, encoder...

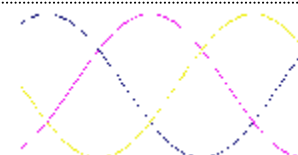

Renesas MCU portfolio covers all 3-phase MC requirements

RL78/G14: 16-bit MCU for Motor Control



Memory

- Program Flash up to 64KB
- SRAM up to 5.5KB
- Data Flash up to 4KB

System

- DTC
- Interrupt Controller 4 Levels, 20 pins
- POR, LVD
- MUL/DIV/MAC
- Debug Single-Wire

Power Management

- HALT RTC, DMA Enabled
- SNOOZE Serial, ADC Enabled
- STOP SRAM On

Clock system

- External Clock 20MHz
- External Clock 32.768KHz
- Internal OCO up to 64MHz
- Internal LOCO 15KHz
- Clock Monitoring

Safety

- RAM Parity Check/protection
- ADC Self-diagnostic
- SFR protection
- Memory CRC

Timers

- 2 x Timer Array 16-bit, 4ch
- Interval Timer 12-bit, 1ch
- Window WDT 17-bit, 1ch
- RTC Calendar

Motor Control

- 3ph MC Timer RD 16-bit with dead time
- Encoder Timer RG 16-bit, 1ch
- Timer RJ 16-bit, 1ch
- ELC

Analog

- ADC 10-bit, 12ch
- Internal Vref.
- Temp. Sensor

Communications

- 2 x I²C Master / Slave
- 1 x I²C Multi-Master
- x CSI/SPI 7-, 8-bit
- 3 x UART 7-, 8-, 9-bit
- 1 x LIN 1ch

On Chip Features

- 1% Internal Clock (64MHz)
- 32MHz CPU
 - Including MUL/DIV/MAC instructions
 - Barrel Shifter
- Motor Control
 - 16bit Motor Control Timer
 - 64MHz Motor Control 3-Phase timer (RD)
 - Timer for H/W encoder (RJ)
 - ADC trigger
 - H/W support
 - Event Link Controller (ELC)
 - Data Transfer Controller (DTC)
- 10-bit A/D
 - Analogue comparator (Larger Devices)
 - Internal temperature sensor
 - Internal Voltage reference
- H/W safety and self test:
 - Flash ECC, RAM Parity, HW CRC, Clock Monitor
 - Windowed WDT, A/D self test, RAM/SFR write protect,
 - Window Watchdog with separate clock
 - Hardware Shutdown (INTP)

Used in the motor control kit

RL78/G14: Typical Applications

■ Typical application fields include:

- Small Appliances
- Fans and Blowers
- Pumps
- Power Tools

Typical application Block Diagram

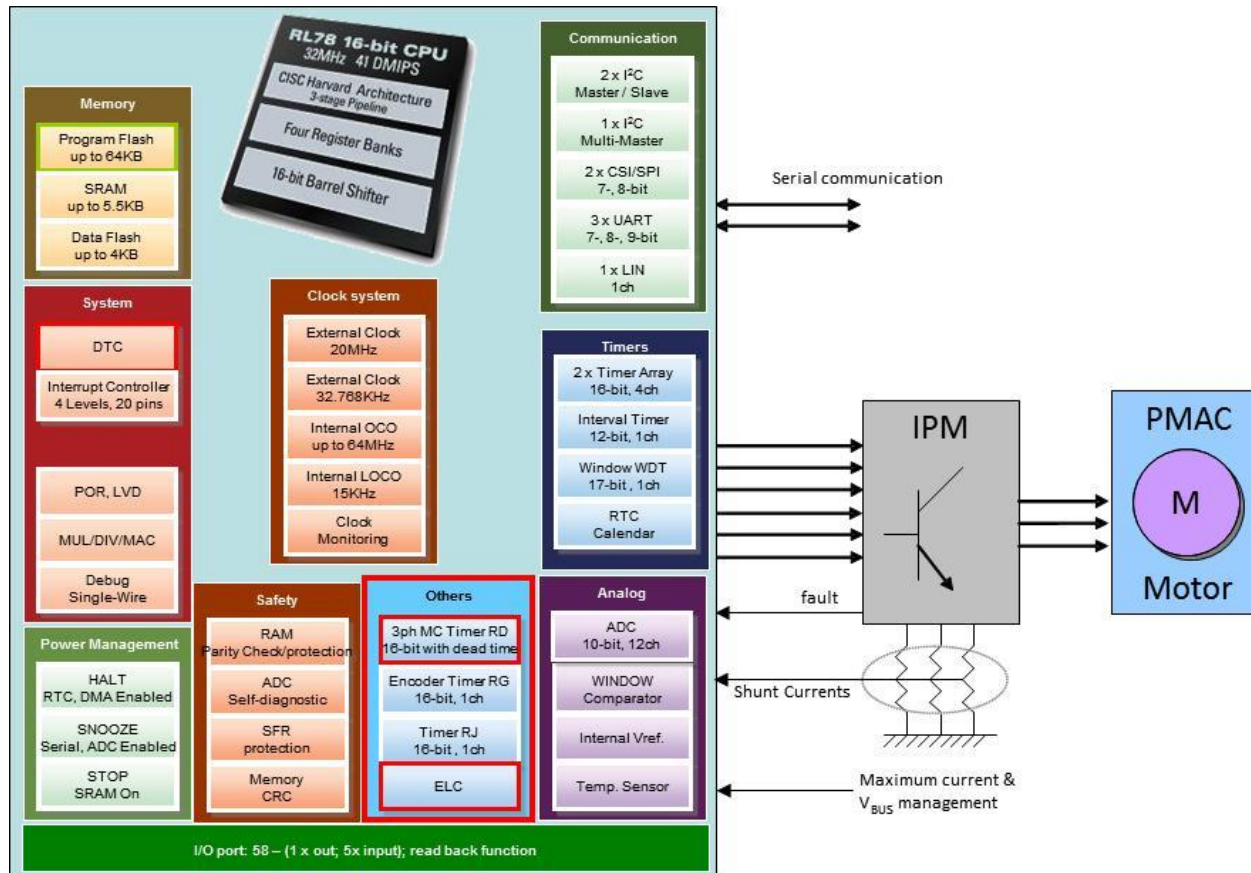

RL78/G14 F.O.C Overview

RL78 F.O.C Sensorless Algorithm

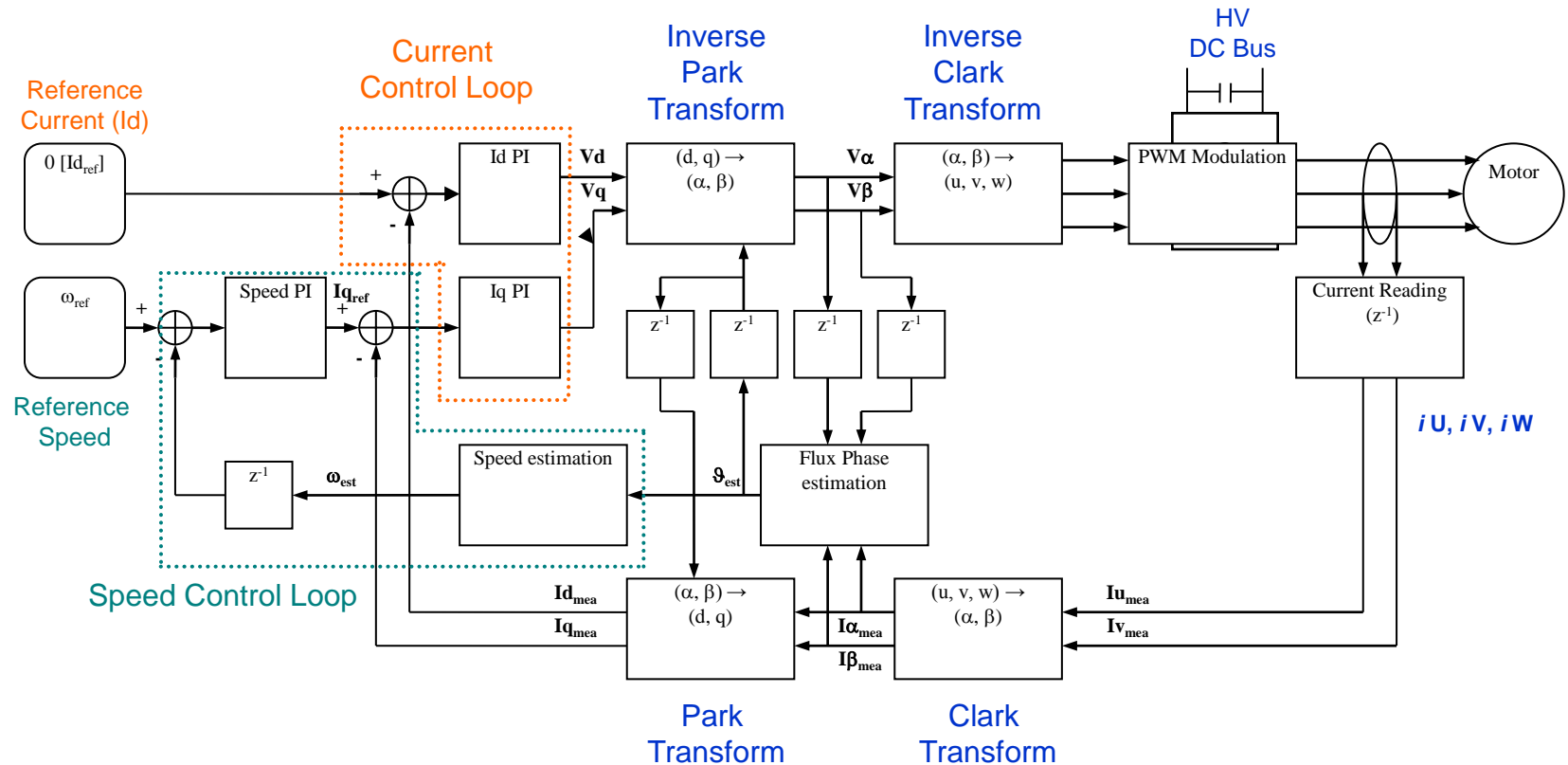

- Variables are Signed Integer

RL78/G14 F.O.C Software Overview

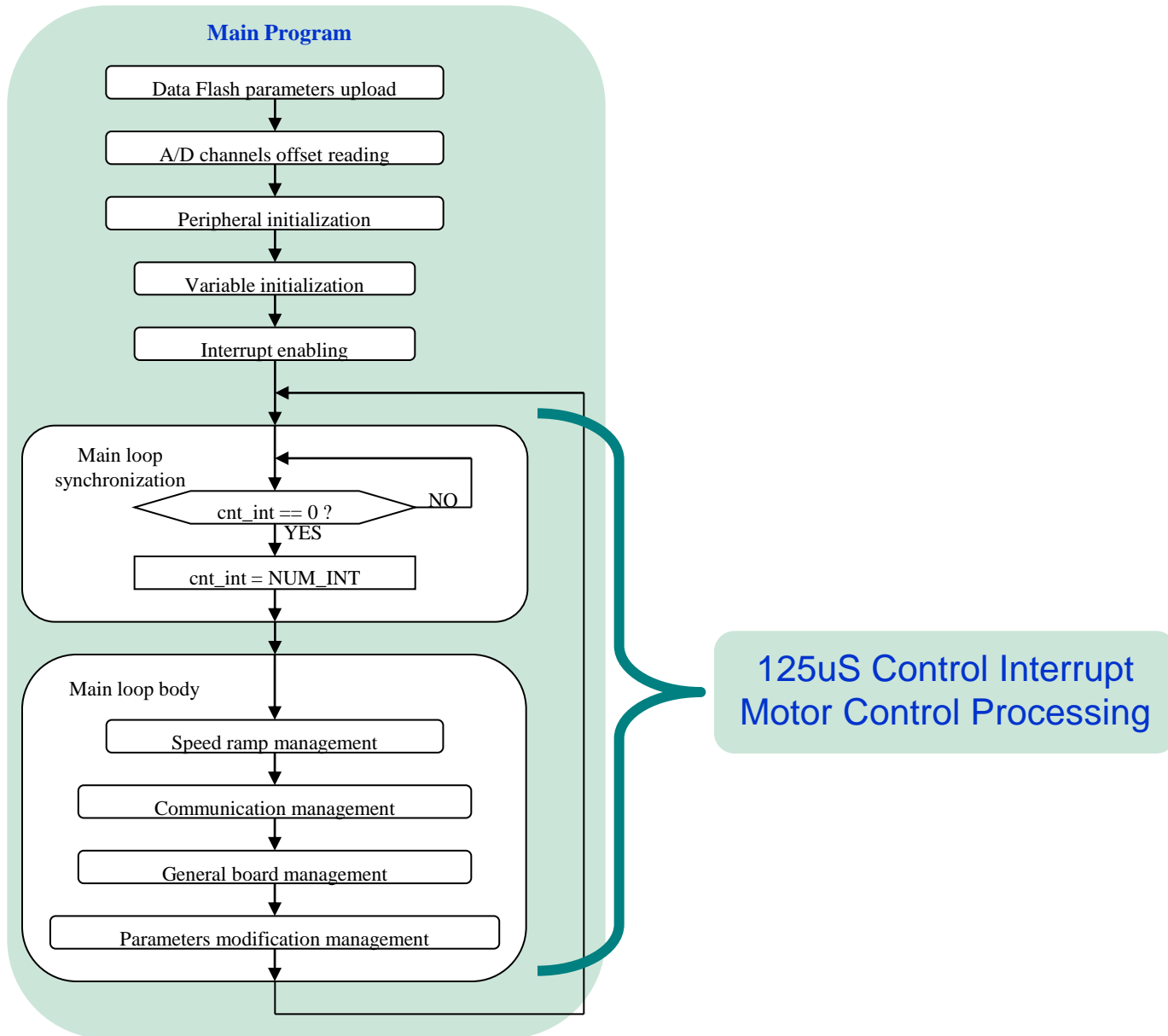

RL78/G14 F.O.C Software Overview

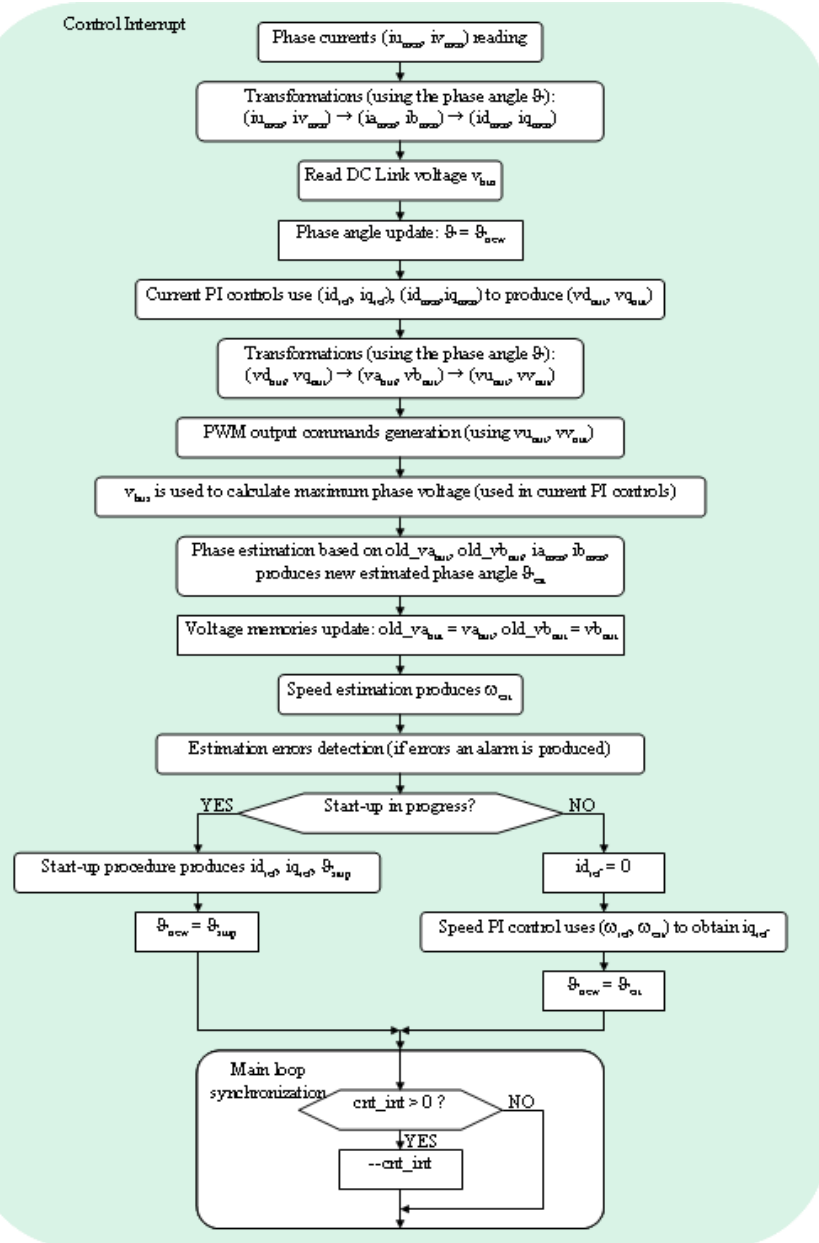

■ Sensorless FOC algorithm

- Signed integer 16 and 32bit variables
- Low level assembler maths functions

- Shift and Add
- Multiply and Shift
- Divide
- Multiply and Divide

RL78/G14 – F.O.C Software Organisation

Modules

C Modules

hwsetup.c

stl_support.c

main.c:

userif.c

par_tab.c

globalvar.c

Function Descriptions

The basic hardware initialisation

Support routines for the self test functions

The main program loop

Communication routines (i.e. GUI)

The Parameter management routines definitions and tables

Global variable definitions

Assembler Modules

self-test

multiply.s87

cstartup.s87

IEC assembler Self test routines (RAM, FLASH, Registers and Clock)

Combined assembler maths functions

Customised start up file for March C RAM test

Library Module

MCRP08_RL78_Lib.r87

Motor Control Library Module

RL78/G14 – F.O.C Software Organisation-Cont

Modules

Function Descriptions

Header Files

customise.h

Basic parameters, not modifiable through the GUI

const_def.h

Definition of the basic numerical constants

mcrplib.h

Motor control library definitions, references and function prototypes

par_tab.h

Parameter definitions, function prototypes and references

hwsetup.h

Hardware definitions, references and function prototype (low_level_init)

globalvars.h

Global variable definitions and references

multiply.h

Assembler Maths function references

mask.h

General support definitions and references

userif.h

General support definitions, references and function prototypes

RL78/G14 F.O.C - Software/GUI Parameter List

Index	Parameter Description	Unit
1	00 Default Parameter Setting	--
2	01 Minimum Speed	RPM
3	02 Maximum Speed	RPM
4	03 Acceleration	RPM/s
5	04 Deceleration	RPM/s
6	05 Polar Couples	--
7	06 Start Up Current	Apeak / 10
8	07 Maximum "q" current	Apeak / 10
9	08 Stator Resistance	Ohm/10
10	09 Synchronous Inductance	Henry/10000
11	10 Start Up Time	mS
12	11 Current Loop Kp	--
13	12 Current Loop Ki	--
14	13 Speed Loop Kp	--
15	14 Speed Loop Kp	--
16	15 Free	--
17	16 Free	--
18	17 Pi Tuning Trigger	--
19	18 Free	--
20	19 Free	--

RL78/G14 Peripheral Hardware Support

- Timer RD
- Interrupt Culling (ELC and Timer RJ)
- Hardware Shutdown (INTP0 pin and HW control)

RL78/G14 Example - Automatic Interrupt Culling

Timer RD: complementary PWM

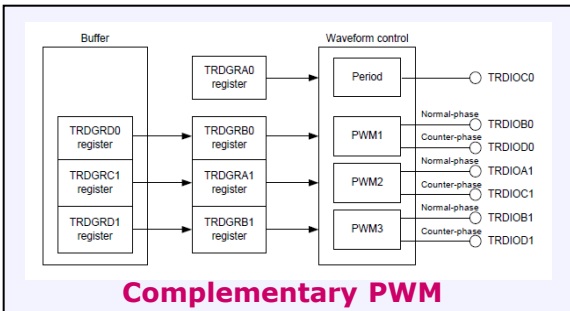

TRD1 Underflow

Timer RD is set to operate in Complementary 3-phase mode:

PWM can be set up to 24KHz

Event Link Controller

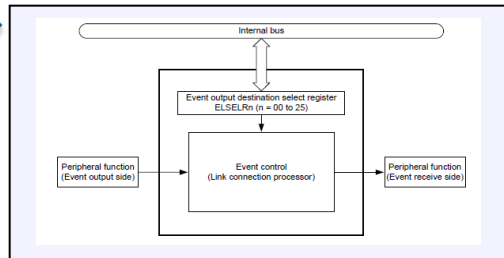

Timer Event Input Trigger

ELC is set to trigger external count in Timer RJ or TAU, when timer RD underflows

Interrupt is not generated, so ISR is not accessed

Timer RJ – event counter

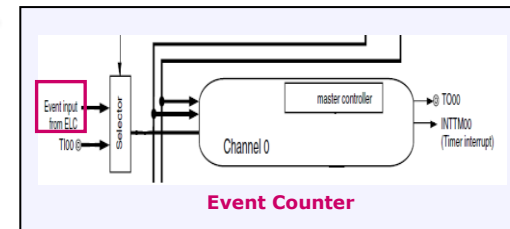

Timer is set to external event count mode. Timer counts down on each ELC trigger. When the count reaches zero the interrupt is generated. (The event count value is reloaded automatically)

This is the Control Loop Interrupt

RL78/G14 Example - Automatic Interrupt Culling

Timer RD

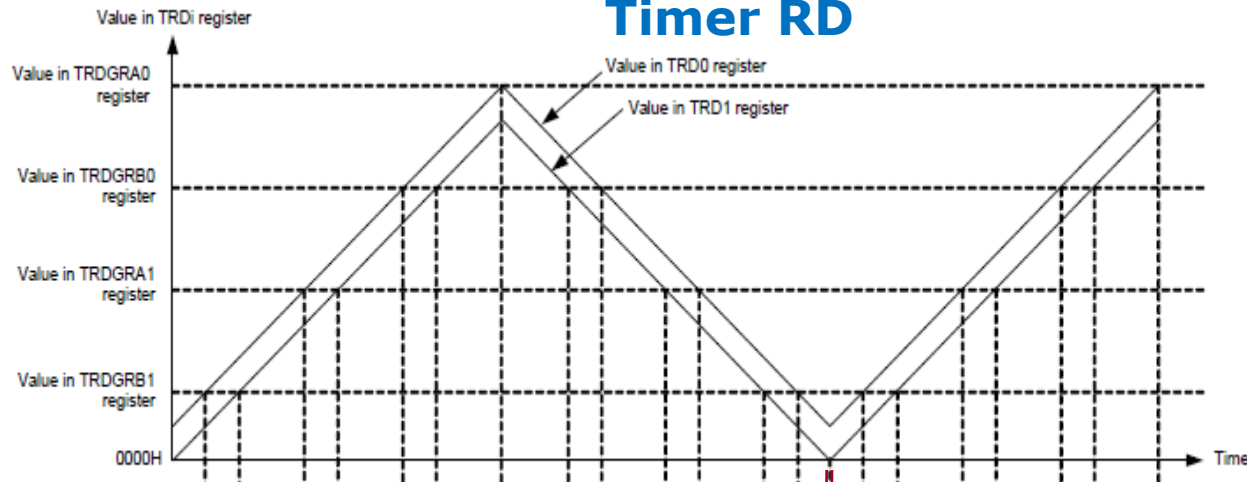

TRD1 Underflow

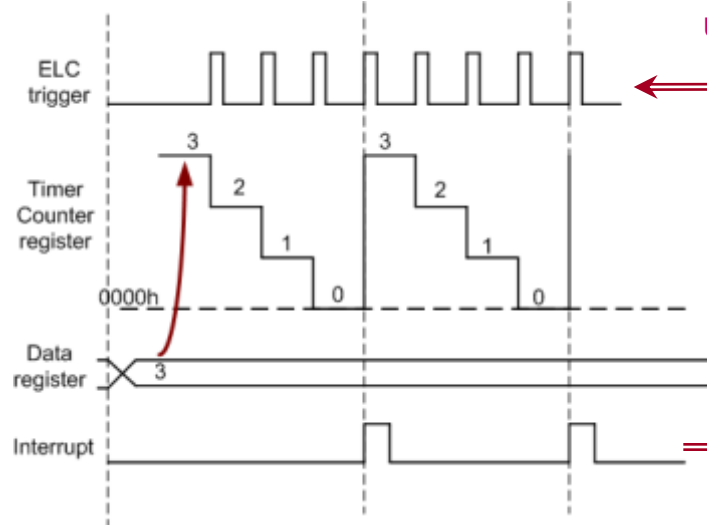

Example Shown

- Timer RD set to 24KHz PWM frequency
- Timer RJ/ TAU set to Event counter
- $24\text{KHz} / 3 = 8\text{KHz}$
- ELC set to trigger Timer RJ (event count) every TRD1 underflow

**Timer RJ/TAU Interrupt
i.e. Control Loop Interrupt**

Timer RJ or TAU (CH0 or CH1)

RL78/G14 – Hardware Shutdown

I/O Port Pin P137 – INTPO

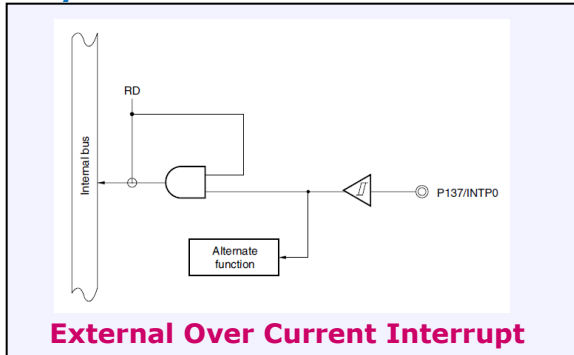

INTPO Interrupt: RD Software Shutdown

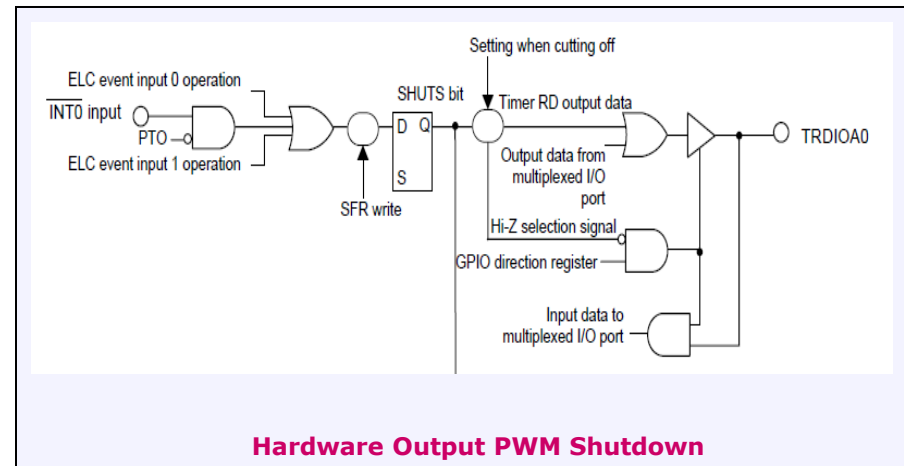
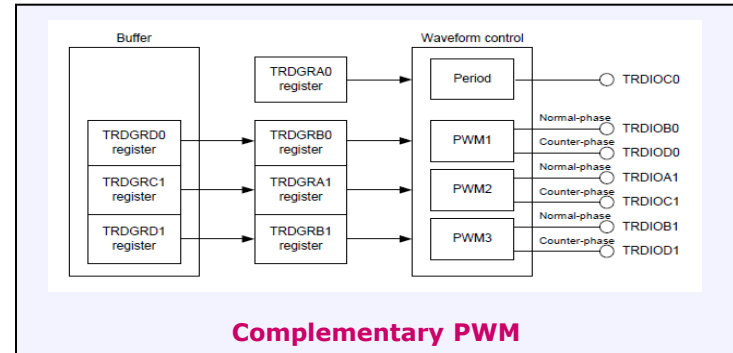

RL78/G14 Self Test / Safety Functions

Self Test / Safety Functions – RL78/G14

Run @ Start Up	User Protection Options (Optional)
Register Tests (Software) USED	Watchdog (Option - clock cannot be stopped Set in Option Byte)
RAM Test (Software) USED	Flash and Data Flash ECC Always On USED
CRC (Hardware) USED	RAM Parity (Hardware Parity generator/checker) USED
System Clock Test (Software or Hardware) USED	Illegal Access Protection (Hardware Detection) USED
	SFR Protection (SFR write protect)
	RAM area Protection (RAM area write protect)



RL78/G14 Motor Control Reference Kit

RL78/G14 Motor control Kit – Board details

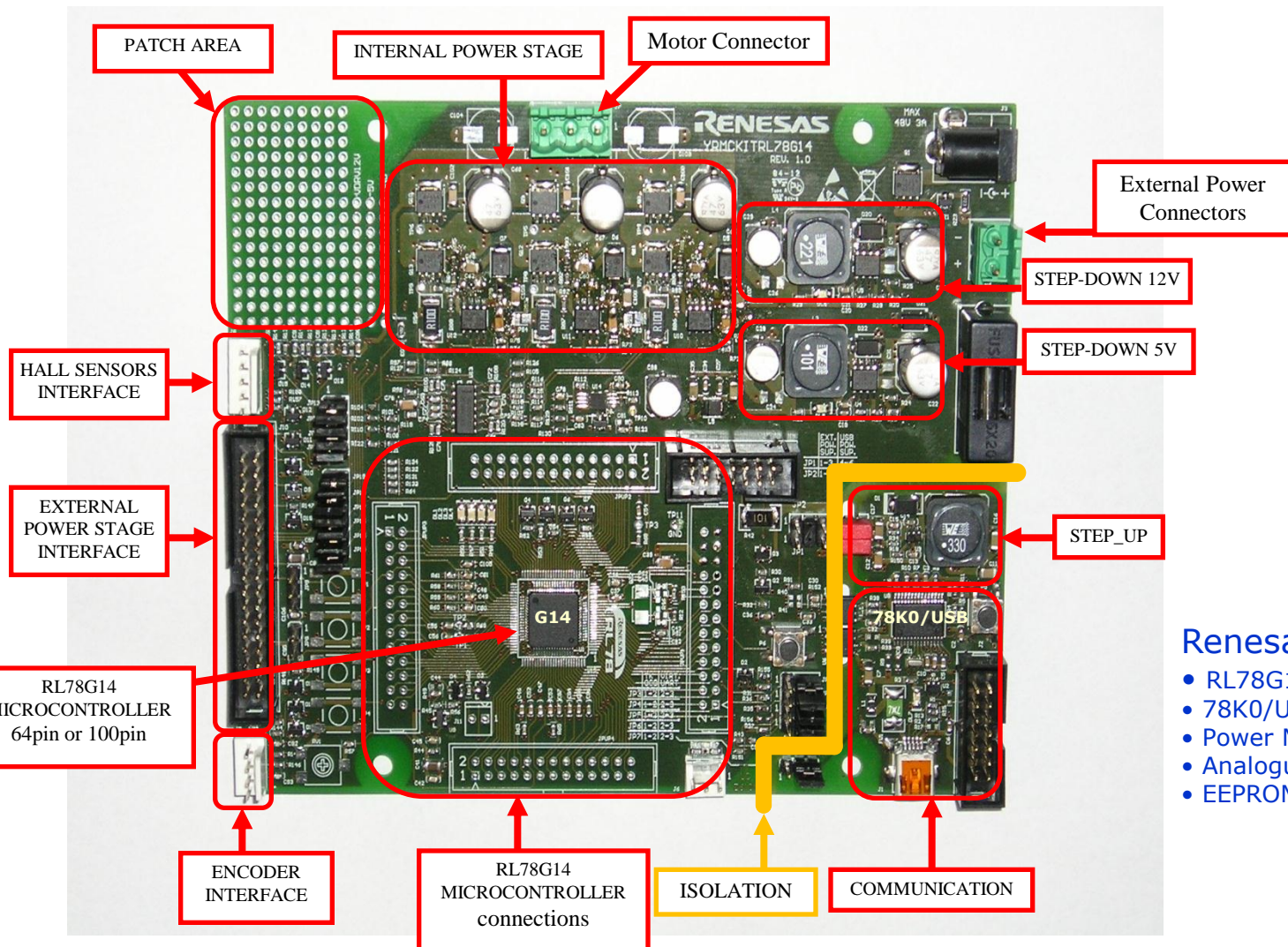

Renesas Parts used

- RL78G14 (R5F104LE or 104PJ)
- 78K0/USB (uPD78F0730)
- Power MosFets - RJK0654
- Analogue Comparator - HAT1631
- EEPROM - R1EX240

RL78/G14 MC Kit - PC Control GUI

Motor Control Demonstrator

RENESAS RL78G14 Demo Kit User Interface
Kit number: YRMCKITRL78G14

RENESAS

Communication Settings
Disconnect

Algorithm information

Parameters Setting

System Monitor

Speed Control

Position Control

Speed Control

SPEED ZOOM VOLTAGE ZOOM CURRENT ZOOM

Reference Measured Direct Quadrature Bus Total Direct Torque Total

STOP UPDATE

Motor Operation graphs
- Speeds, Currents and Voltages

Function Tabs

Motor Control
- Start, Stop, Speed and Direction DEMO Mode

RPM CONTROL

0 2333 4667 7000

DEMO

PROPERTY MONITOR

Motor speed

Motor speed 0 rpm Imposed F... 0.0 Hz Direct Curr... 0 mA Torque Cur... 0 mA Direct Volt... 0.0 V

DC Bus Vol... 13.6 V Alarm Code 0

Save data to file

Property Monitor where motor parameters can be analysed

- Speed, Currents, Voltages, Torque
- Operation and Parameters can be saved to Excel file

Parameters Setting

DESCRIPTION	UNIT	MIN	MAX	VALUE	VALID
00. Default Parameters Setting	-	0	32767	0	true
01. Minimum Speed	rpm	200	5000	2000	true
02. Maximum Speed	rpm	1000	20000	7000	true
03. Acceleration	rpm/s	1	10000	4000	true
04. Deceleration	rpm/s	1	10000	2000	true
05. Polar couples	-	1	4	2	true
06. Startup Current	Apk/10	0	5000		
07. Maximum Current	Apk/10	0	5000		
08. Stator Resistance	Ohm/10	0	5000	40	true

Reload Write

Motor Tuning Parameters

System Monitor

Clock frequency: 32MHz
Flash occupation: 15KB
RAM occupation: 2KB
PWM modulation frequency: 16KHz
Sampling frequency: 8KHz

March C Test CPU Regs Test Motor Alarm
CRC Test Clock Test

System Parameters

Exit

RL78/G14 Motor control Kit Resources

Resource	Usage	Value	Notes
Device	R5F104LE (64KB (F), 5.5KB (R) 4KB (DF) R5F104PJ (256KB (F), 24KB (R), 8KB (DF))	64pin 100pin	Dual footprint supported
Flash Memory	Source Code	13KB	Includes <ul style="list-style-type: none"> ■ Motor control algorithm ■ GUI serial interface ■ Data Flash interface ■ IEC Self test code
	Constants	2KB	Includes <ul style="list-style-type: none"> ■ Motor Control Algorithm ■ Reference CRC table ■ Data Flash Library
RAM Memory	All variables	2KB	Includes <ul style="list-style-type: none"> ■ Motor control algorithm ■ Data Flash Library ■ Self Test variables
Timing	Control Loop Interrupt	8KHz (125uS)	Includes <ul style="list-style-type: none"> ■ Motor Control Algorithm ■ Data Flash interface ■ GUI interface
	Control loop execution time	86uS	70% CPU used



Renesas Electronics Europe

© 2012 Renesas Electronics Europe. All rights reserved.