

Renesas Electronics Business Policy

Renesas Electronics Corporation

August 2, 2011

Yasushi Akao, President

Introduction

–Recovery and Reconstruction

Following the Great East Japan Earthquake-

Recovery from the Earthquake- Completion of Naka Factory Restoration

- Great support from outside and inside the Renesas Group helped to speed up the resumption of operation by three months

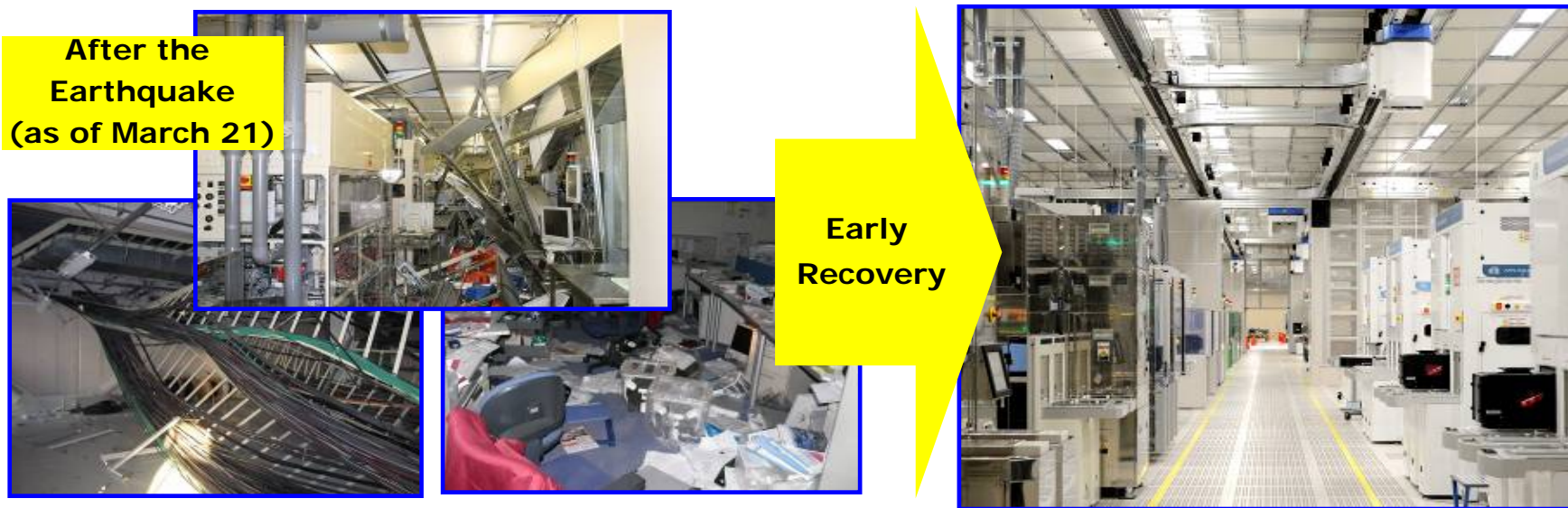

- Expect the supply capability to reach the pre-earthquake level by the end of September

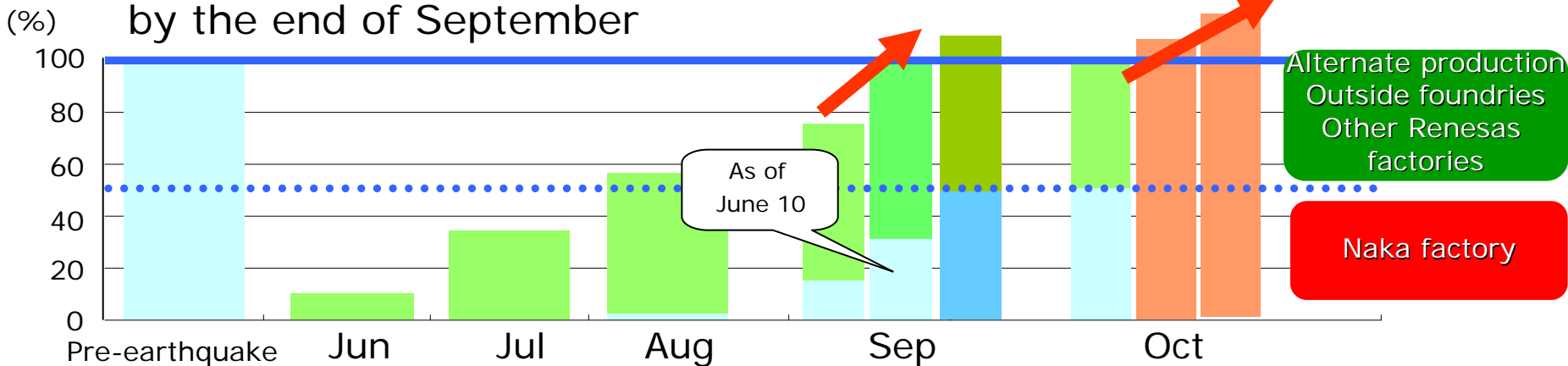

Impact of the Earthquake and Efforts toward Recovery, and Measures for Mid-Term Growth

- Carried out recovery from earthquake with utmost effort
 - Grateful for all of the help from everyone involved
- Accelerate transformation of business portfolio following the earthquake

CY2010

1H/CY2011

2H/CY2011

CY2012

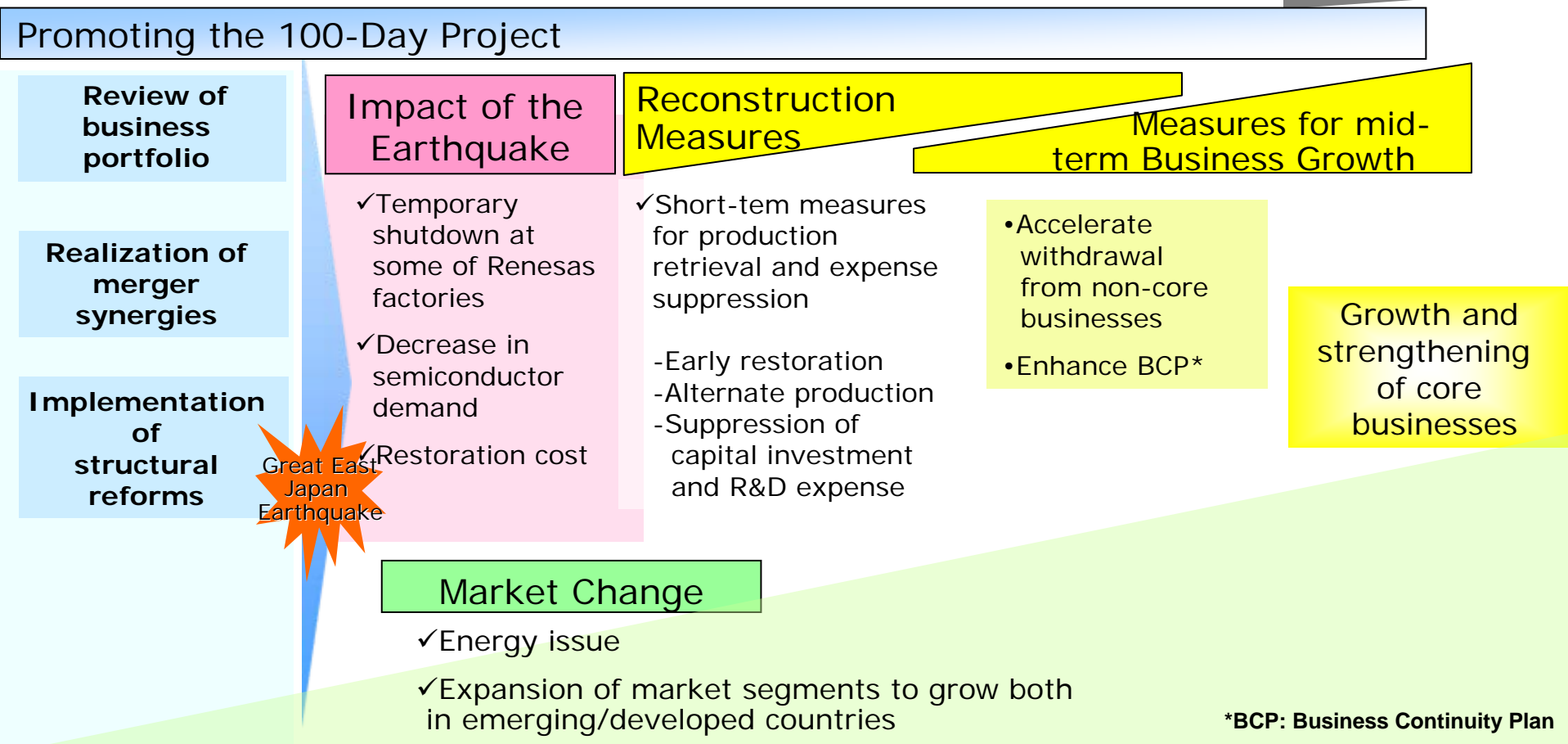

*BCP: Business Continuity Plan

Executive Summary

1. Business Focus of Renesas Group

2. Strengthen Core Business -Focus Market

3. Business Continuity Plan (BCP)

4. Summary of Business Policy

1. Strengthen Core Business -Focus Market (1) Keywords to Market Development

Key Words: "Overseas Market", "Emerging Countries" and "Smart Society"

- Capture **overseas market** with high growth potential
 - ✓Rapid economic development in **emerging countries**
 - ✓Increasing range of functions in electric equipment and automobiles and growing demand for reasonably priced products

- Increase in electric power consumption accelerates the movement toward **"Smart Society"**, enabling efficient use of energy resources

- **"Smart Society"** is expected to expand both in developed countries and **"Emerging Countries"** and **"Smart Society"** and expect to lead the semiconductor market as a driving force

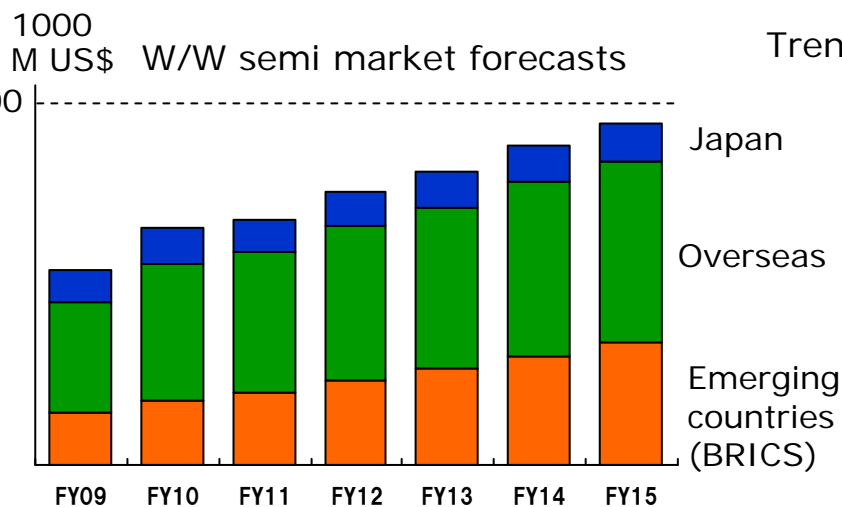

Trends in electric power consumption W/W (by region)

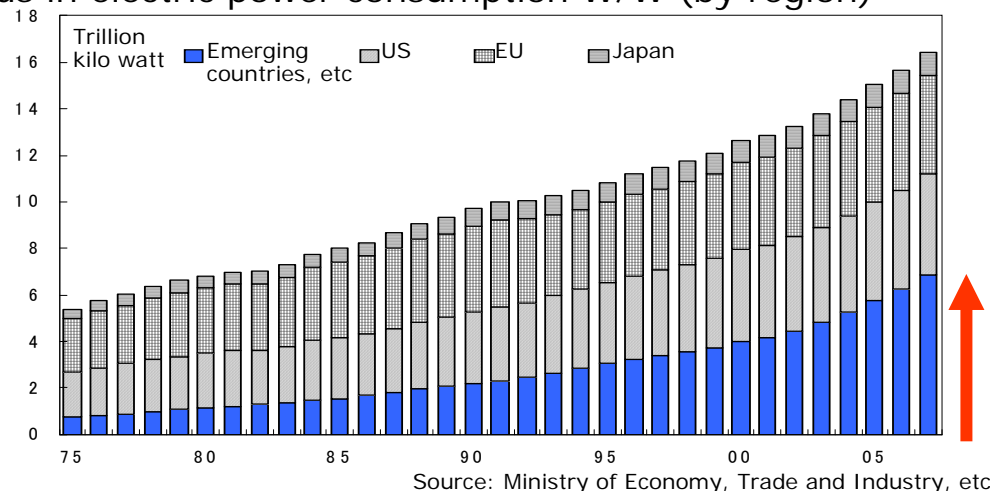

Source: WSTS, Renesas

Source: Ministry of Economy, Trade and Industry, etc.

Toward "Smart Society" through Coexistence with the Global Environment

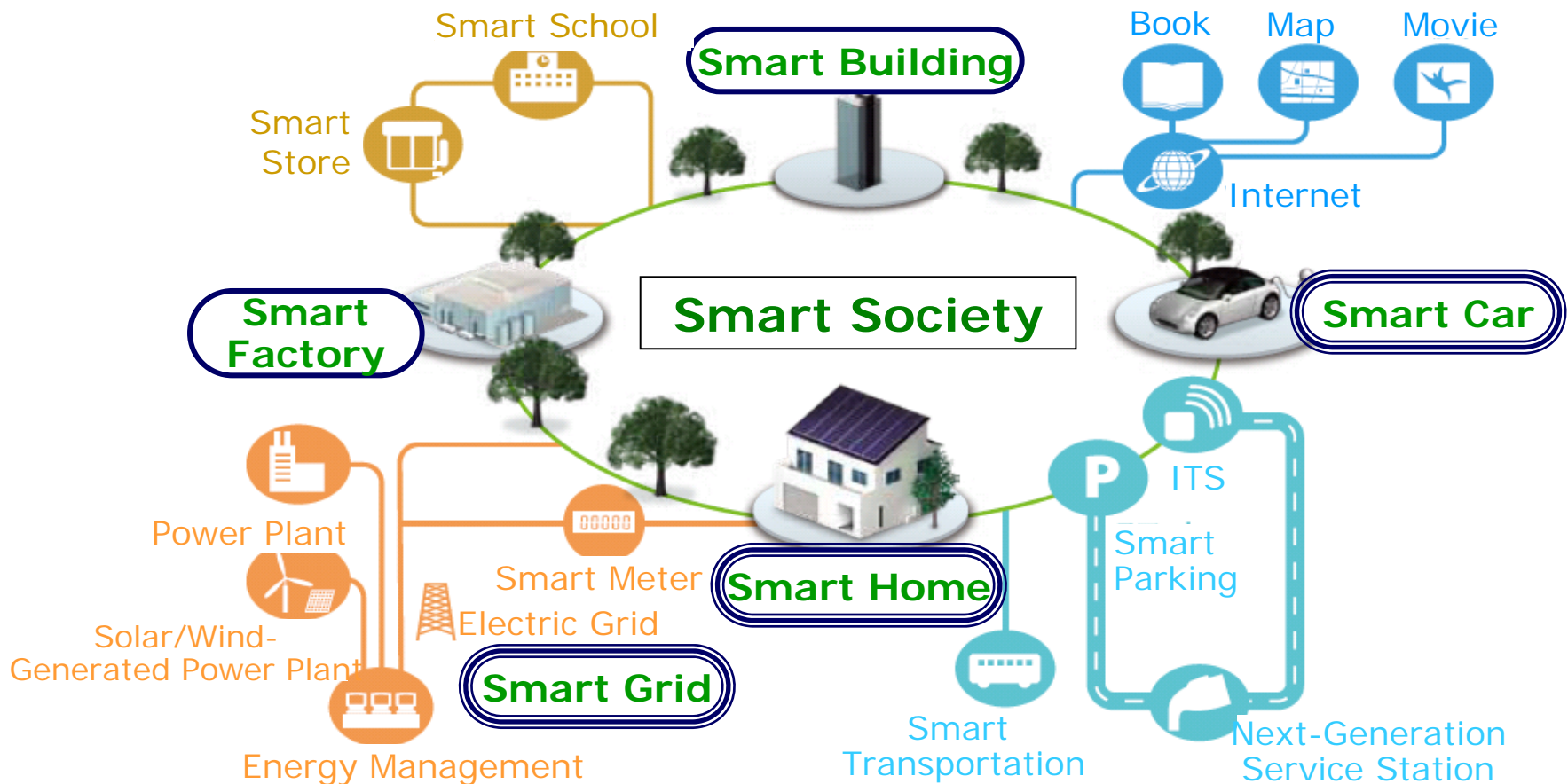

With the energy condition and zero-based infrastructure in addition to environmental conservation and convenience, smart society will develop both in emerging/developed countries
=> Expansion of market segments to grow both in emerging/developed countries



1. Strengthen Core Business -Focus Market (2)Market of "Smart Society"

Renesas' World-Leading Products for Smart Society

- Further enhance lineups of one-kit solution with power and analog devices evolving around the strong MCUs

Smart Society Market	 <p>Smart Grid</p>	 <p>Smart Home</p>	 <p>Smart Car</p>
System/ Application	<ul style="list-style-type: none"> •Power generation/ storage •Energy management •Smart meter •Wireless/PLC* 	<ul style="list-style-type: none"> •Energy-saving home appliance •Home network •LED lighting •Mobile device •Healthcare equipment 	<ul style="list-style-type: none"> •Next-generation automobile (HEV/EV) (Infrastructure for electric charge) •Transportation system (ITS/ETC) •Car navigation



#1 World's #1 Business (Source: Renesas)

Renesas Products	<ul style="list-style-type: none"> #1 MCU for meter -IGBT -PFC (Power factor correction IC) -ASIC for industry application 	<ul style="list-style-type: none"> #1 Low-power MCU #1 MCU for inverter motor #1 Low-voltage MOSFET -IGBT -LED driver -ASIC for industry application 	<ul style="list-style-type: none"> #1 Automotive MCU #1 MCU for EV/HEV motor -IGBT #1 SoC for car infotainment system -LTE modem #1 ASIC for industry application
------------------	--	--	---

Approach to Smart Grid Market

- Semiconductor market for Smart Grid applications as the new promising market to grow drastically

1 million USD

Semiconductor Market for Smart Grid Applications

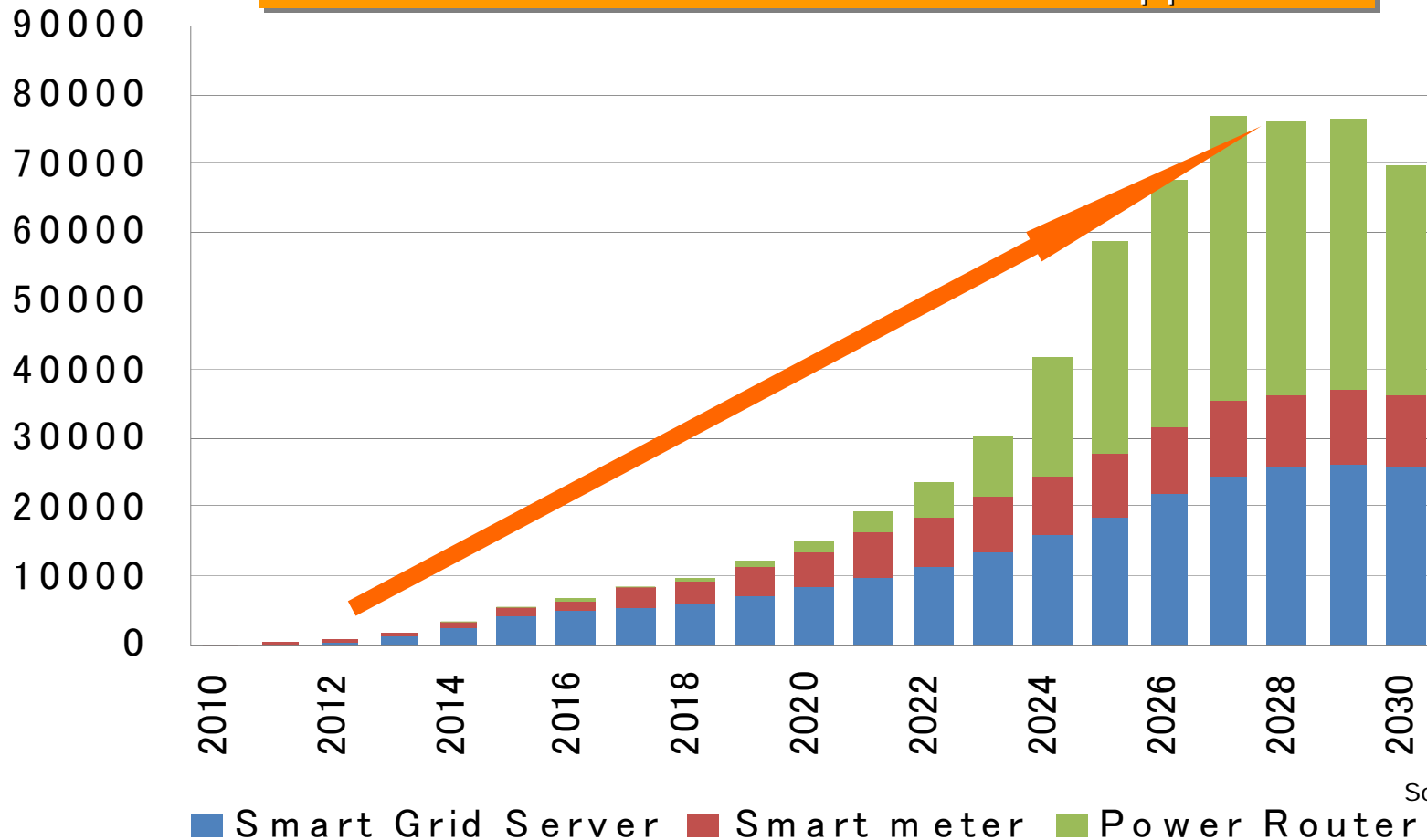

Source: iSuppli

Approach to Smart Grid Market

■ Provide solution for Smart Meter, a key component for Smart Grid

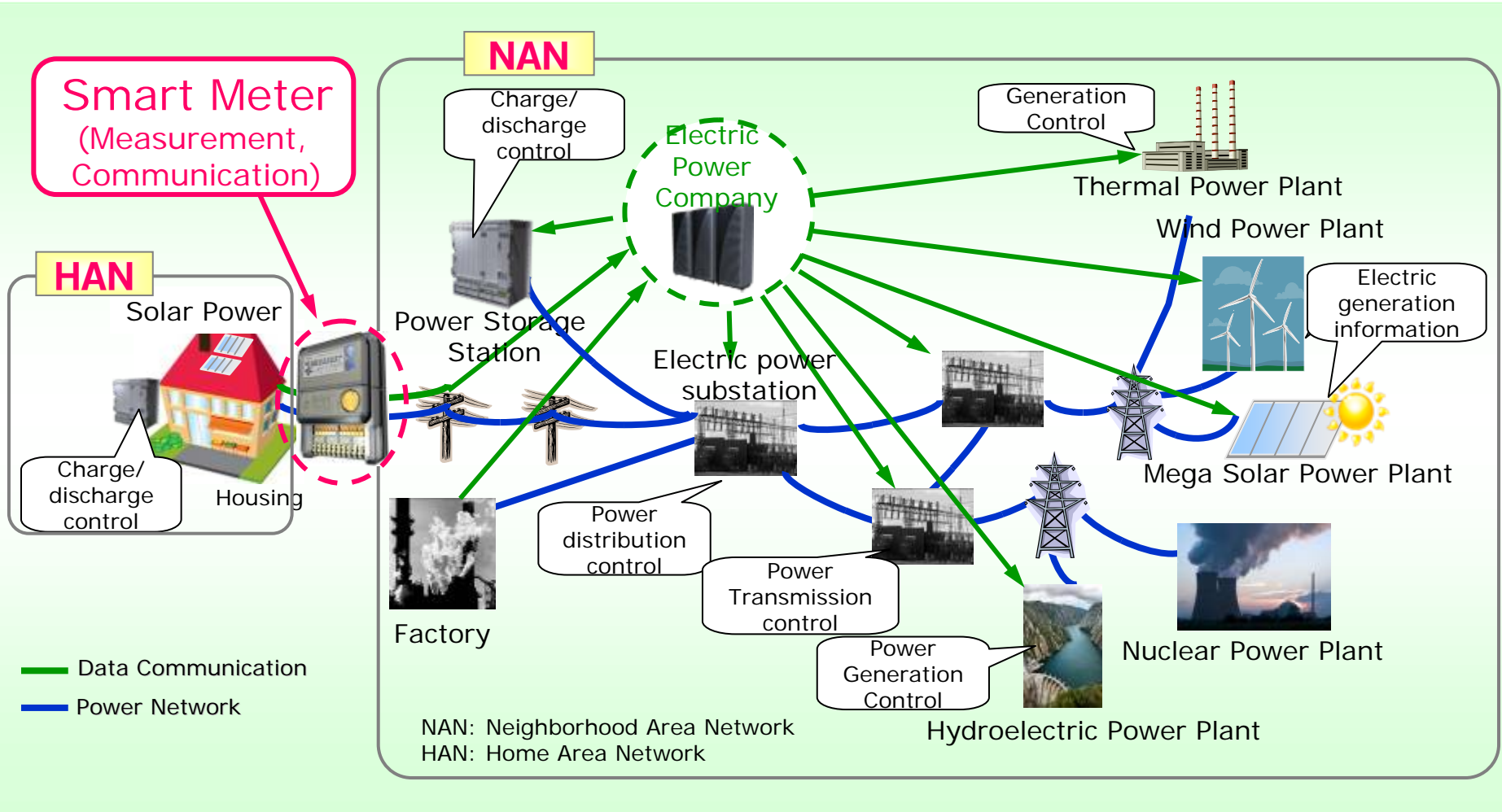

Smart Meter Solution

- Aggressive approach to Smart Meter market, that has high market growth rate and requires multiple MCUs
- Strengthen solutions for meter/communication unit based on proven track record as the top supplier of MCUs for meter

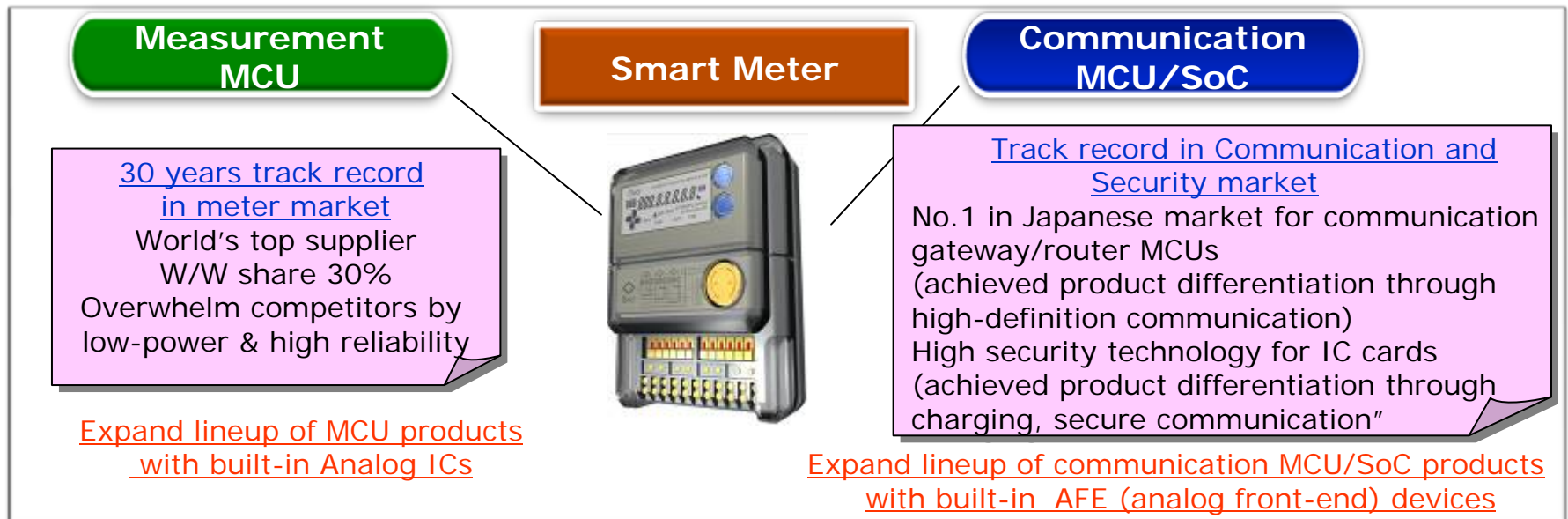
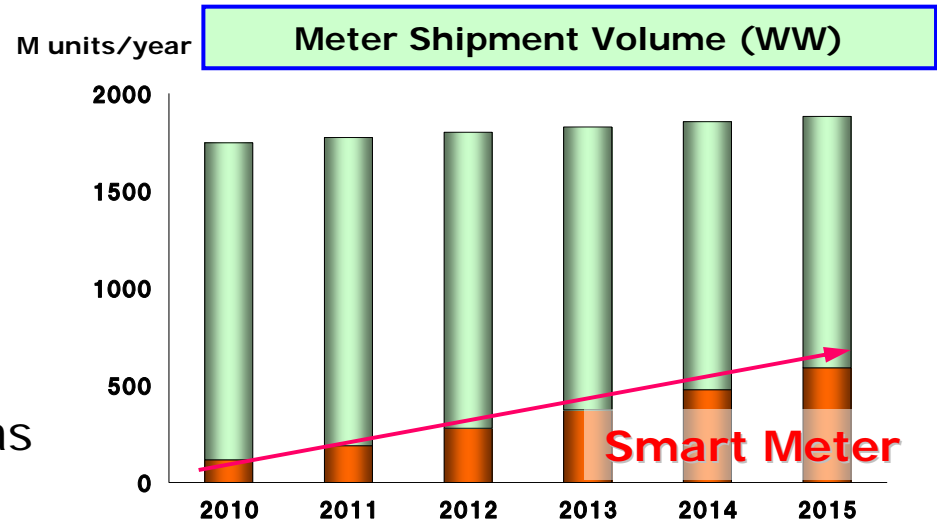

Approach to Smart Home Market

- Aggressive promotion of MCU and Analog & Power products to the inverter-controlled home electronics and LED lighting markets globally expanding with increasing awareness on energy conservation

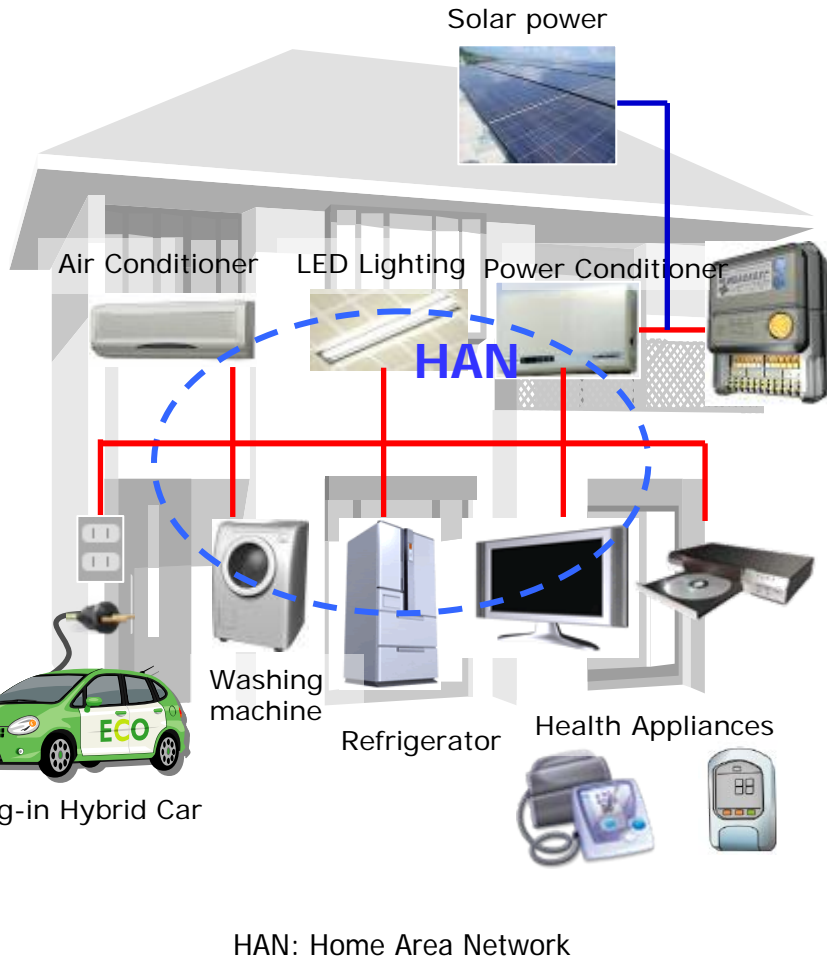

Inverter-controlled home electronics

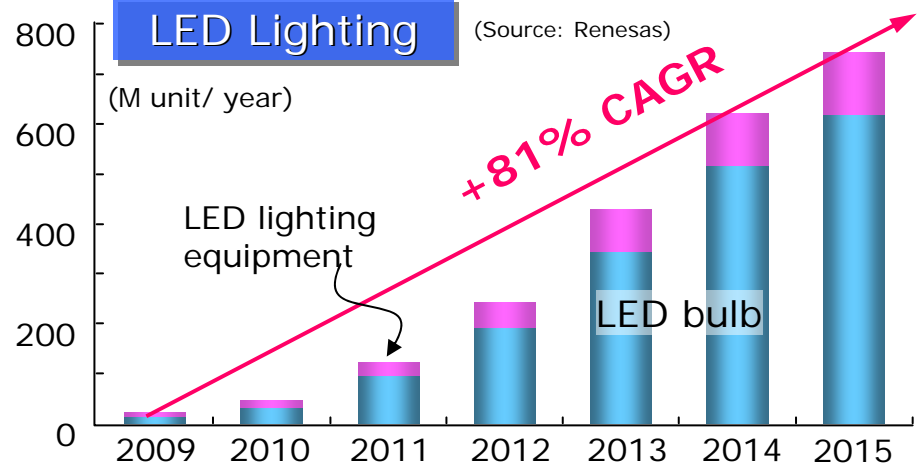
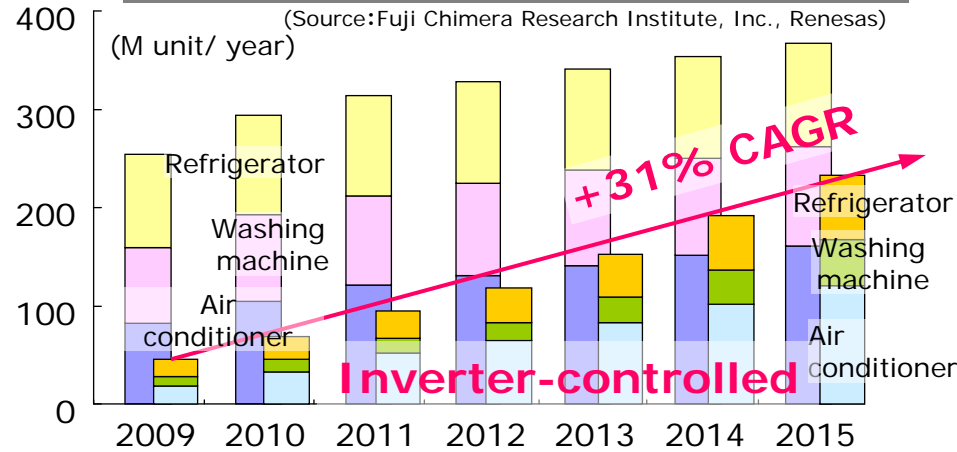

Solutions for Inverter-Controlled Home Appliances

- Provide inverter-control MCU (40% W/W share) together with Analog & Power products as one kit-solution

Inverter-controlled home appliances

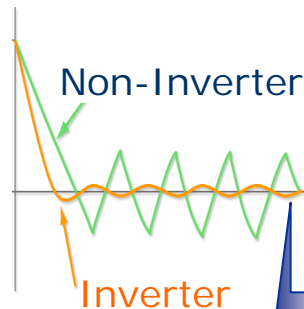

Provide solutions

- Inverter Control**
- low power consumption
 - Fine-tuned temperature control
 - low noise

Low-power inverter MCU

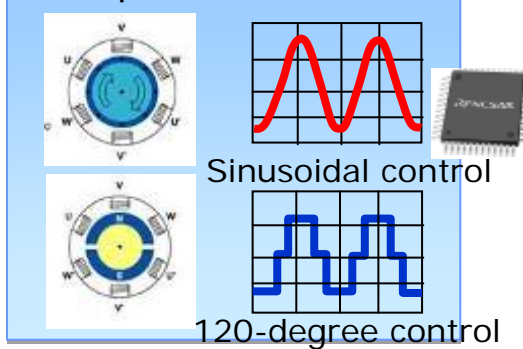

+ Analog & Power products

- IGBT
- Photo Coupler
- PFC (Power Factor Correction)
- Power MOS

Reference board for inverter motor (Renesas MCU + A&P)

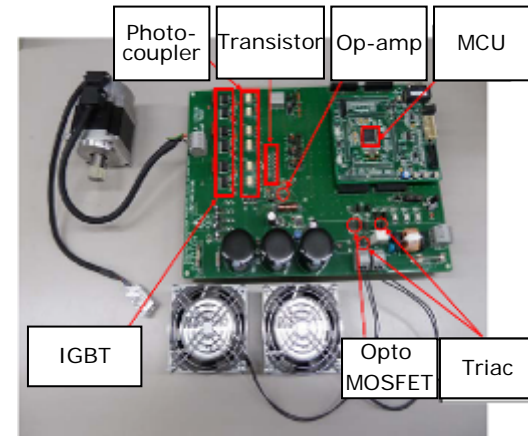

Reference board for PFC (Power Factor Correction)



LED Lighting Solution

Provide full lineups of MCU solutions with analog drivers for various LED lightings together with enhanced development environment

Low system cost

Light bulb/
Down light, etc

Analog LED driver

AC power supply (incl. PFC)



Analog LED driver

DC power supply (excl. PFC)

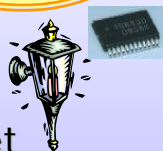

Solar street lighting, etc

PFC: Power Factor Correction

Communication function/
Multi-channels driver

Base light/
Ceiling light, etc

MCU + LED driver

MCU with communication function + LED driver



Analog 4ch LED driver



Illumination, etc

SiP solution MCU + 4ch driver



MCU

Driver IC



• [Software automatic-generation tool](#)

› Reduce software development time

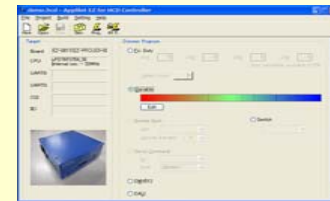

• [LED lighting reference](#)

› Evaluation of LED lighting dimmer control
› Evaluation of DALI/DMX512 communication

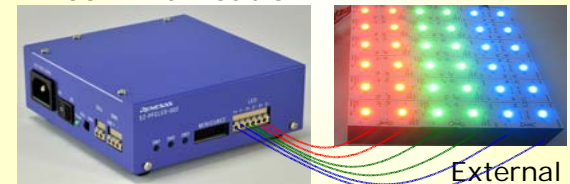

DALI: Digital Addressable Lighting Interface
DMX512: Common communication standard for stage lighting

Approach to Smart Car Market

- Automotive semiconductor market is expected to increase steadily driven by growth in emerging countries and rise in HEV/EV ratio

Automotive MCU :
5.1B US\$ (CY2010)

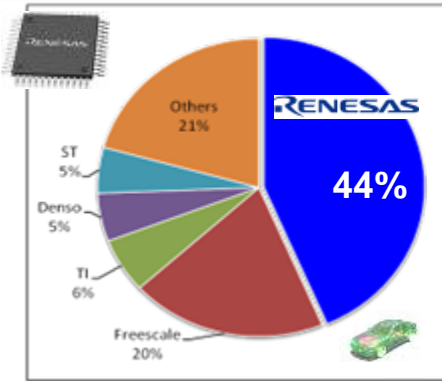

Automotive Semiconductor Market Demand Trend

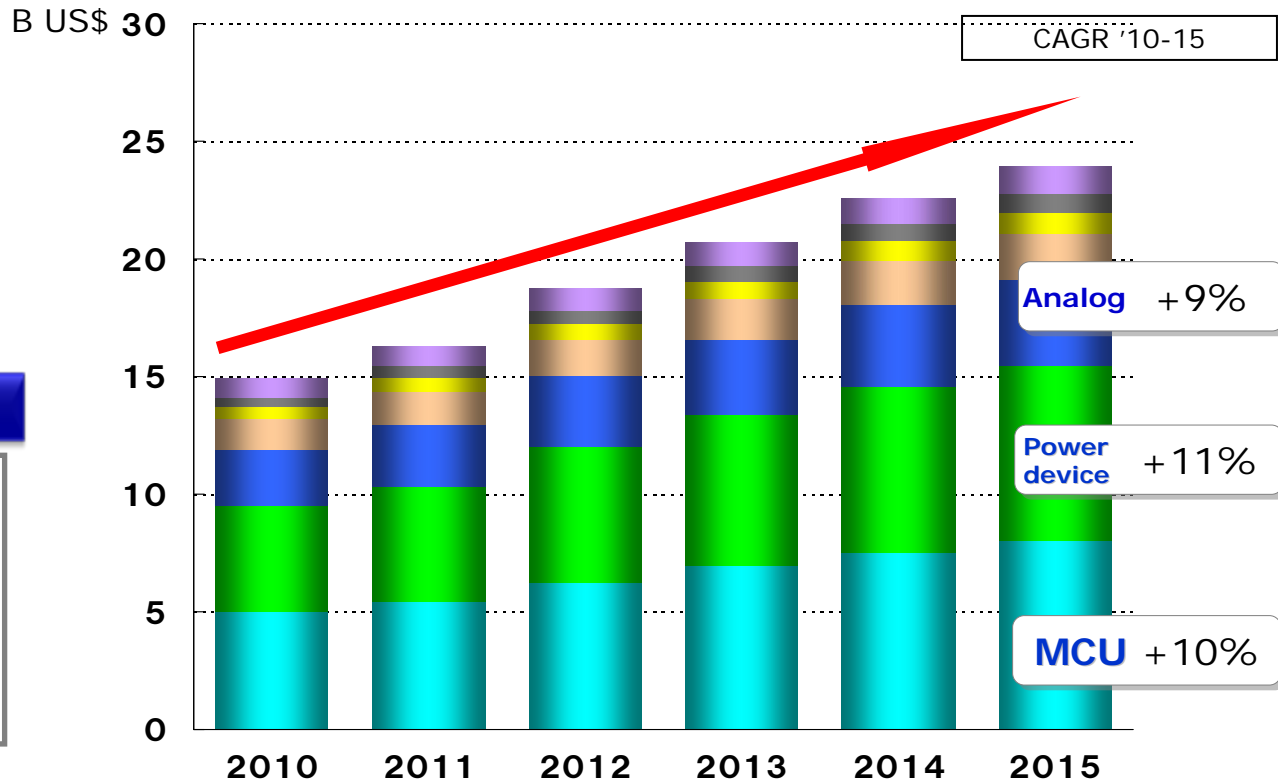

Source: Renesas, Gartner & Strategy Analytics (April 2011)

Automotive Analog IC :
\$2.7B US\$ (CY2010)

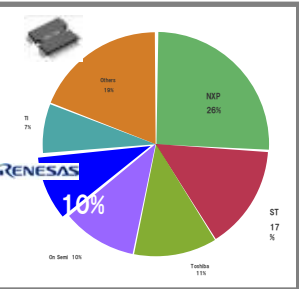

Automotive Power Device:
4.1B US\$ (CY2010)

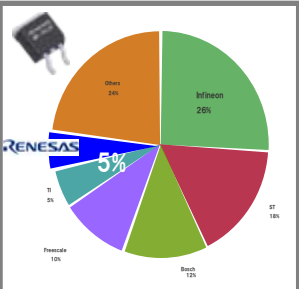

Smart Car Solution

- Expanded lineup of A&P products for automobiles, Provide as a kit-solution with MCU
 - Reduce development time by offering a sample software
 - Provide timely support for customers' evaluation by offering a demonstration board

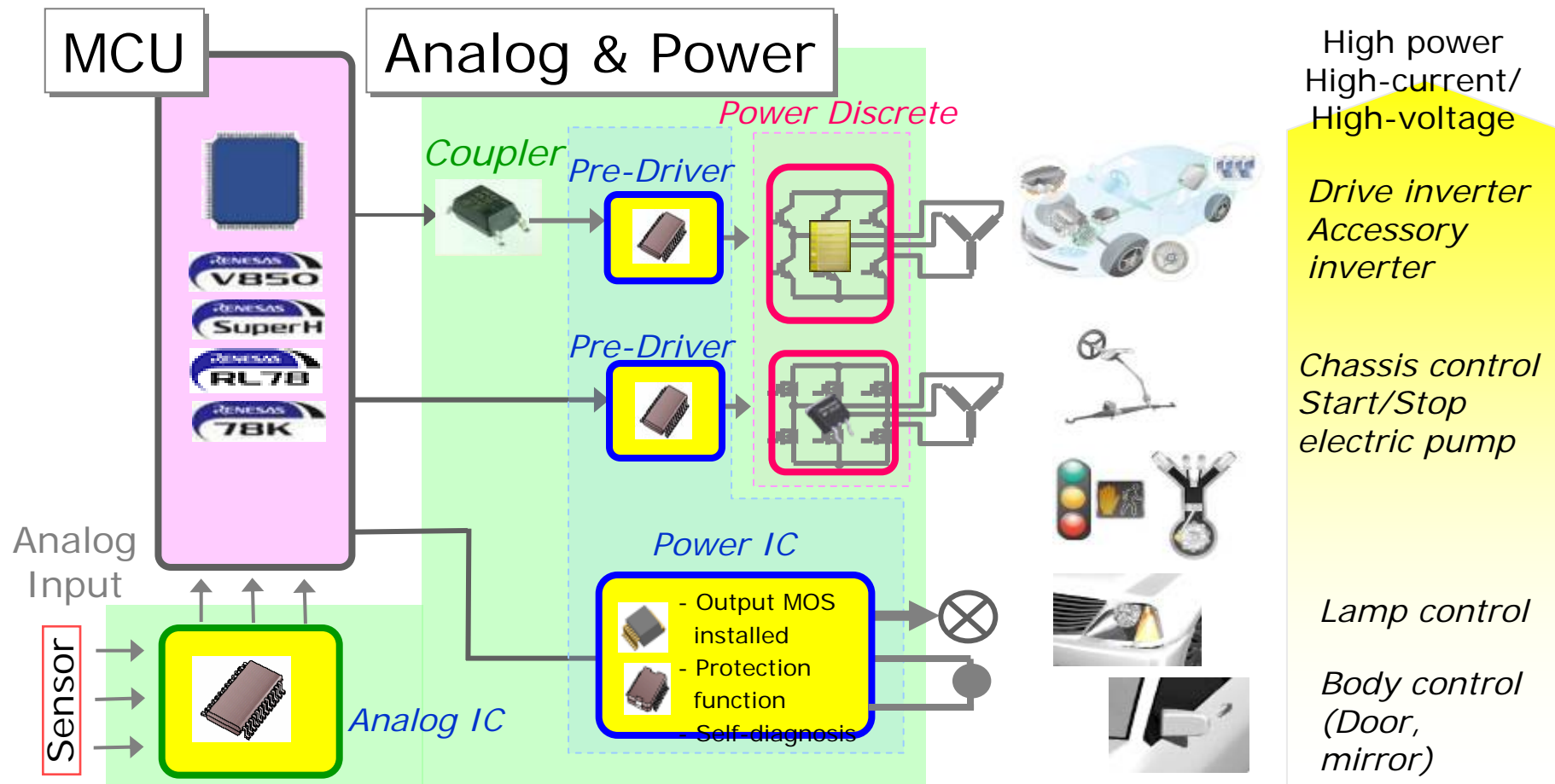

1. Strengthen Core Business -Focus Market (3)Global/Emerging Market

Approach to Emerging Markets

- Future semiconductor market growth will be led by China and other emerging countries

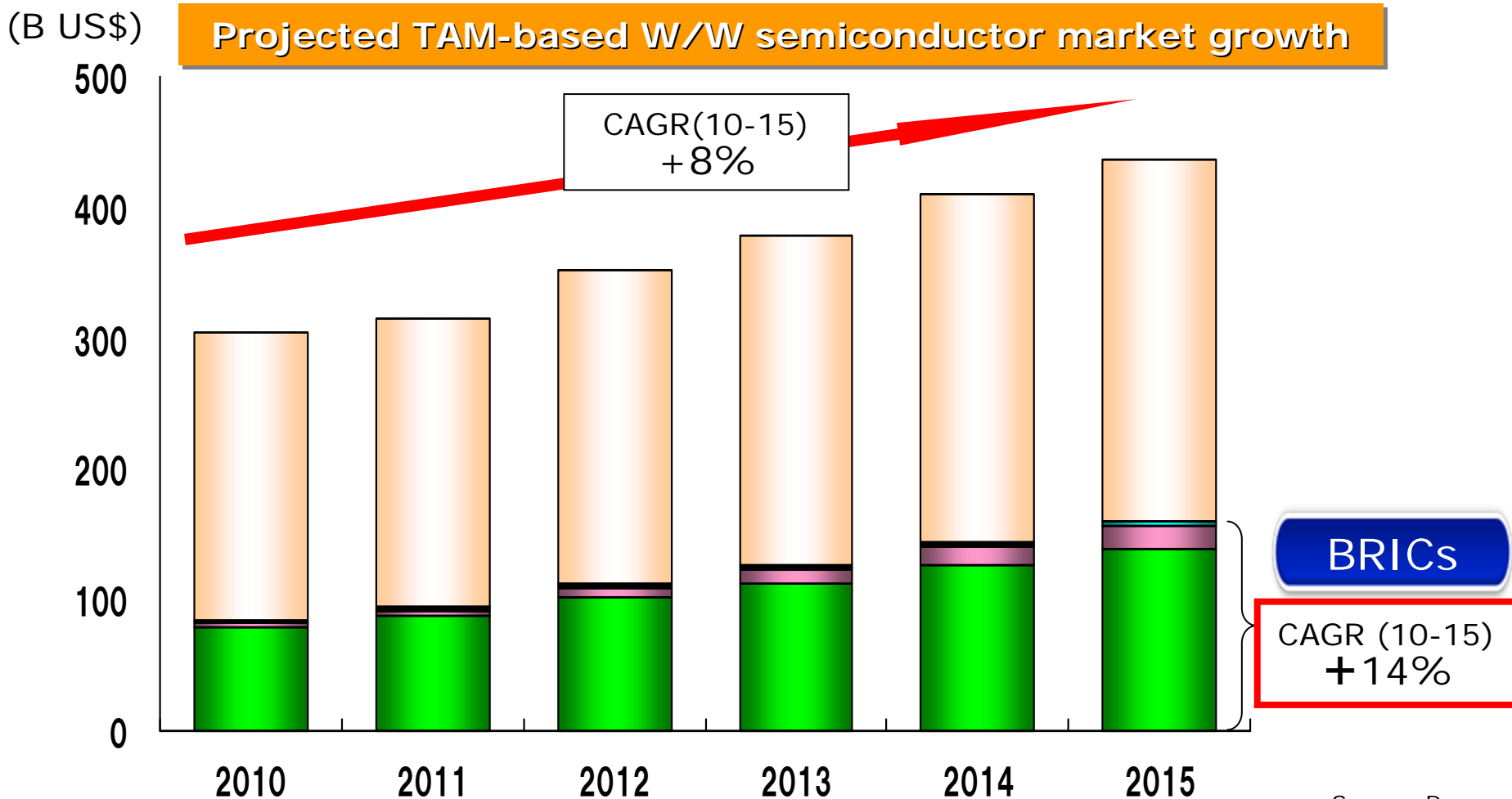

Source: Renesas

Approach to Emerging Markets

Amidst a rapid expansion of MCU market in China, Renesas attained the position as the market leader leaving competitors far behind

MCU Sales of Chinese Market

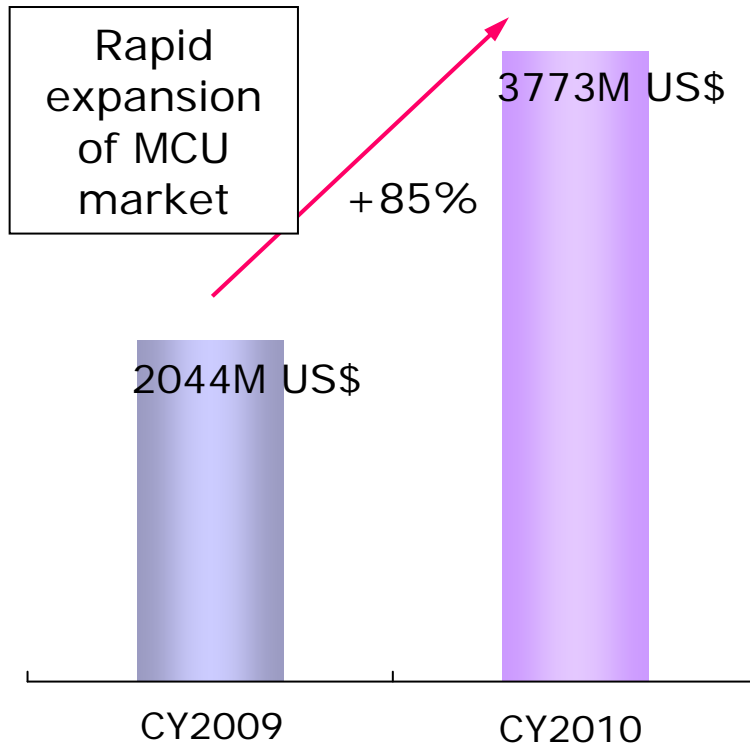

MCU Share of Chinese Market

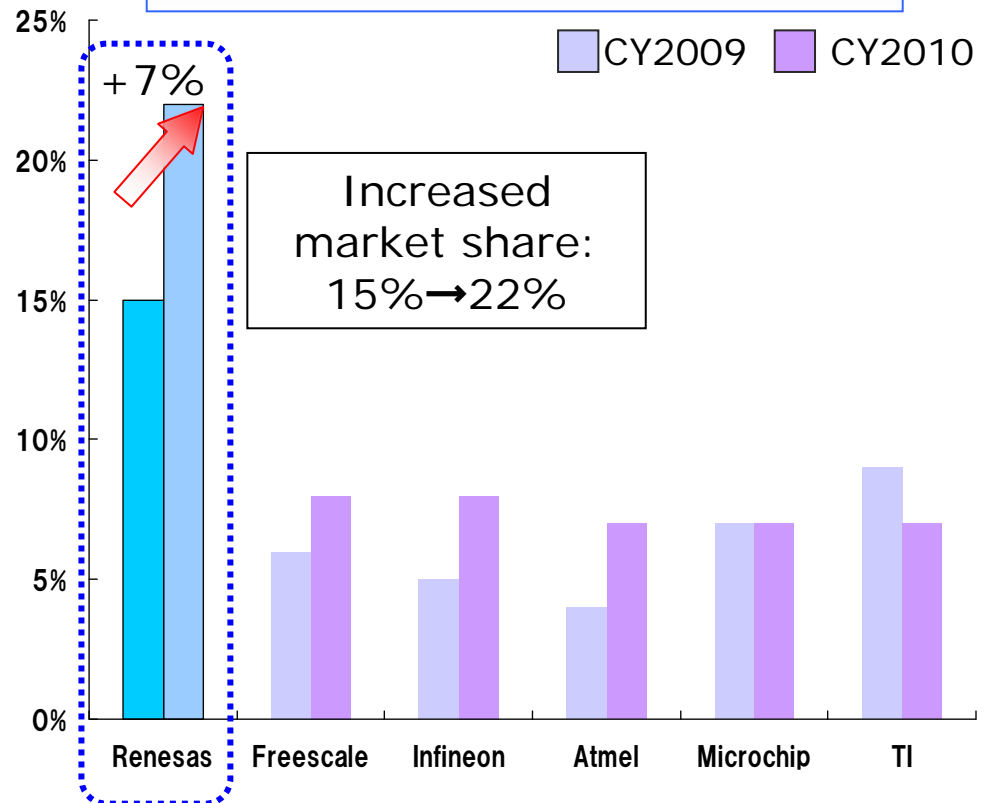

Source: IHS iSuppli 2011

Approach to Emerging Country Markets

- Built a comprehensive structure facilitating local development based on local needs with the market-leading, rich lineup of elemental technologies and products that correspond with expanding areas

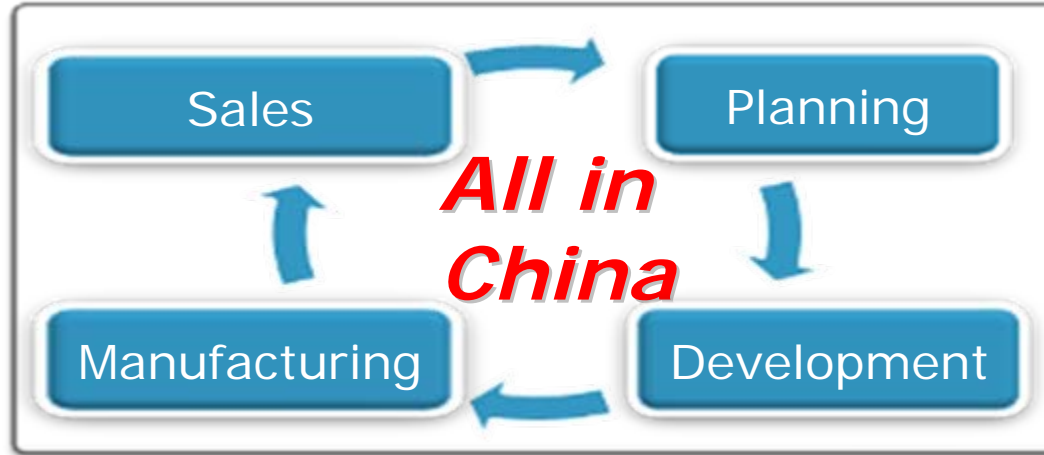

Plan to launch products that address local needs
(1st product available now)

Social infrastructure



100 products

Energy-saving home appliance



600 products

Automobile
(EV/HEV, e-Bike)



100 products

Home environment
(Home security, etc)

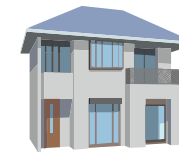

200 products

Approach to Emerging Country Markets

- Efforts to grow sales in the next promising Indian and Brazilian market that have a huge potential for growth with enhanced local-based support

Chinese Market

Oct. 2010

- Started operation of "MCU China Business Unit"
- Raised CY10 MCU market share to 22% from 15% in China
- <Semiconductor TAM: 78,950M US\$(FY10)>

Indian Market

Jan. 2011

- Opened a local branch of Renesas Electronics Singapore in Bangalore to enhance sales and support for the market with huge growth potential
- <Semiconductor TAM: 3,600M US\$(FY10)>
- <CAGR(10-15): +38%>

Brazilian Market

- Contracted with a local distributor to promote sales
- Started to study to open Renesas branch office
- <Semiconductor TAM: 1,600M US\$(FY10)>
- <CAGR(10-15): +15%>

Source: Renesas

Approach to Overseas Market

- Provide the best solutions combining MCUs and A&P products tailored to overseas market demands

Competitive A&P products in Japan



Provide the best solutions to overseas customers

	MCU	Transistor	Analog IC
Japan	64% 1st	17% 2nd	6% 4th
US	16% 2nd	2% 15th	Below 15th
EMEA	23% 1st	3% 11th	Below 15th
ASIA	17% 1st	6% 5th	Below 15th
W/W	29% 1st	8% 4th	2% 14th

Launched Marketing Unit (Apr. 2011)

→ Unified marketing functions of MCU and A&P

- Consolidation of eco-system for A&P sales (Complete by the end of Aug. 2011)
 - Consolidate enough sales infrastructure to the same level of MCU
- Consolidation of sales tools combining MCUs and A&P products
 - Application catalogs and demo boards are available
- Study to provide incentive for selling kit solutions

Big potential for sales growth

- ✓ Lack of infrastructure to promote sales of A&P
- ✓ Insufficient sales tools for system configuration
- ✓ Emphasis on MCU promotion and sales by distributors

Power Management	Transistor	DAC
LED Dr.	MEMS	AMP
Sensor	MCU	ASSP
Buffer	Timing	I/F
Digital IC	Memory	Opt coupler



Source: Renesas, Gartner, Analog (General-purpose linear IC)

2. Business Policy by Business Segment

2. Business Policy by Business Segment

(1) MCU Business

World-Leading Renesas MCU

- Firmly maintained top positions both in general-purpose/automotive MCUs with 29% market share w/w

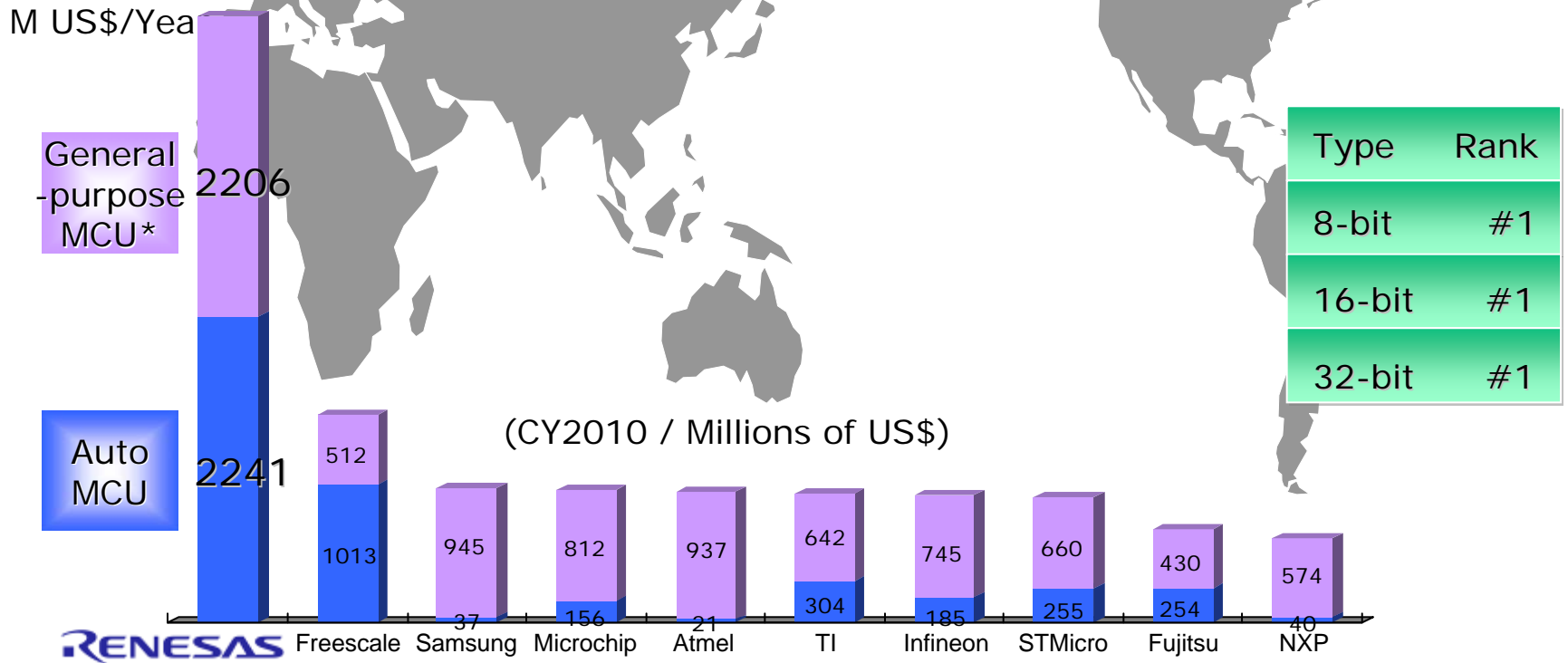

*General-purpose MCU: MCU market for applications excluding automotive

Source: Gartner, "Market Share: Semiconductor Applications, Worldwide, 2010," 30 March 2011, "Market Share Semiconductor Devices Worldwide 2010" 30 March 2011, Chart created by Renesas Technology based on Gartner data. Renesas Technology's MCU revenues in the 1st quarter (Jan. - Mar.) of 2010 has been combined in Renesas Electronics' MCU revenues in 2010.

Strength of the MCU Business

■ High Quality

<Safety improvement>

Target zero-defects

-Currently boasts 0.4ppm
(parts per million)

■ Low Power

<Support promotion
of green products>

World-leading low power consumption

-Achieved 55 μ A/DMIPS with RL78 MCU

■ Integrate Tools

<Provide best-fit
development environment>

Integrated GUI (Graphical User Interface)
supports user operability

RL78, RX, SH, V850

■ Support Structure

<Offer industry-leading
hospitality>

Extensive alliance with over 700
partner companies worldwide
to provide detailed assistance

■ Global Network

Local support structure to support
customers worldwide

Exceptional High Quality

- Utilizing the strength as an IDM, realized percent defective of 0.4ppm through cross-sectional zero-defect activities from design to manufacturing

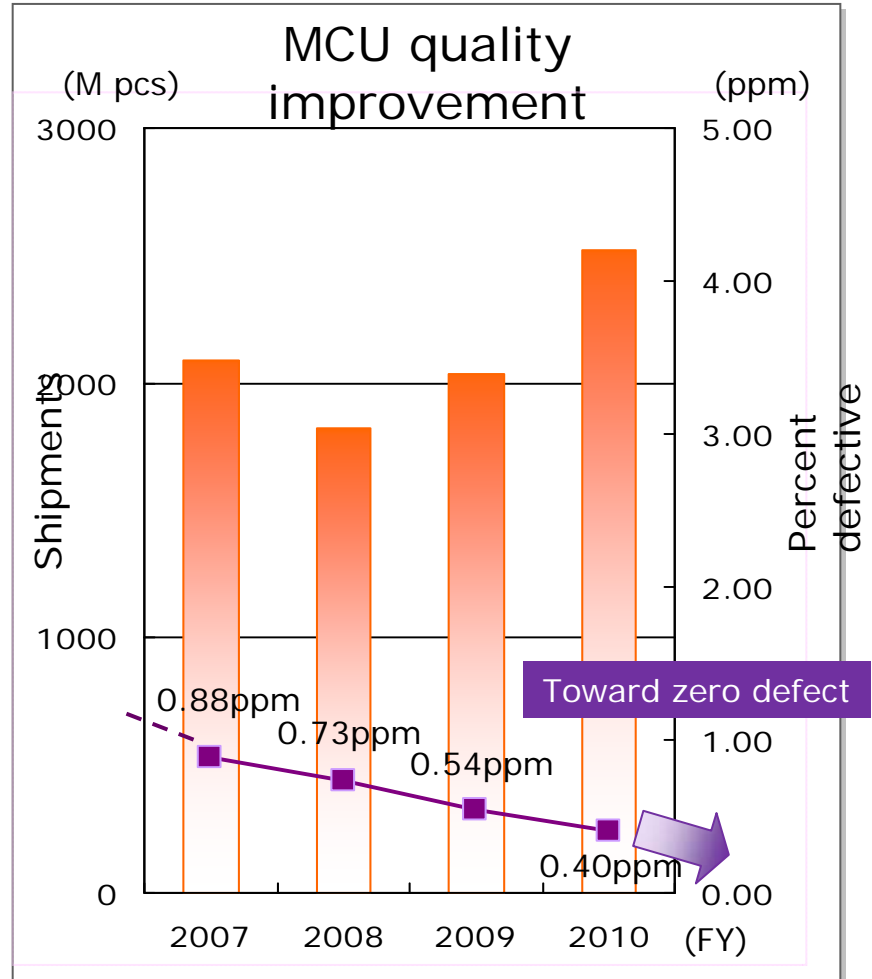
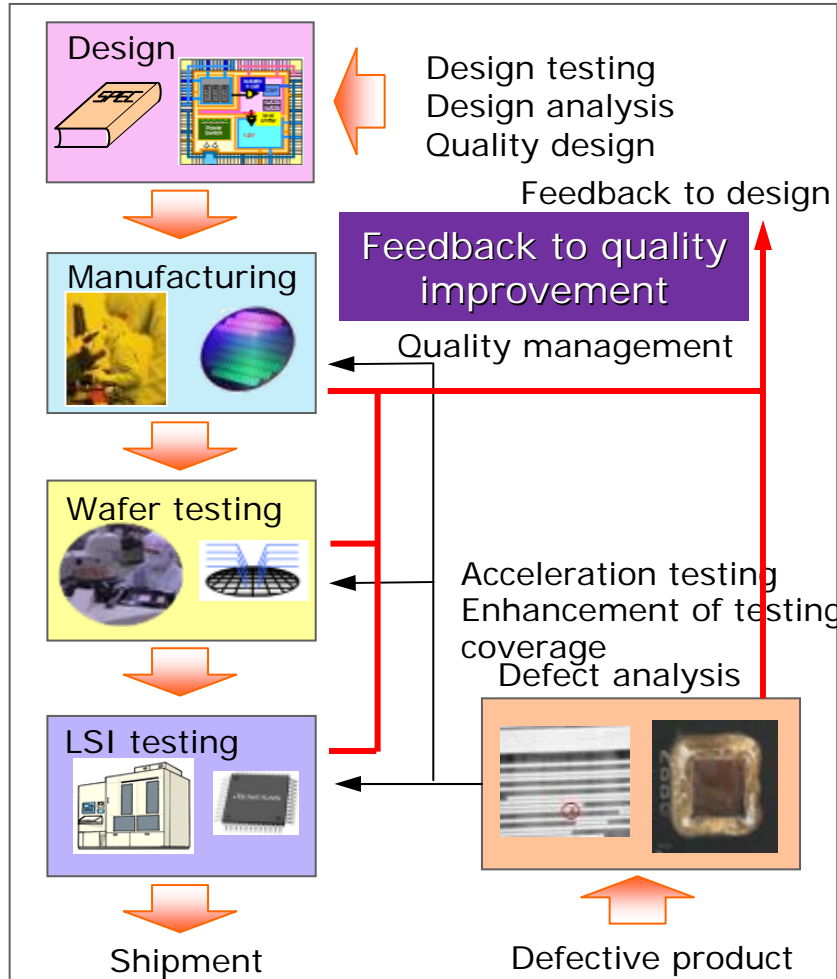

Out-and-Out Efforts toward Low Power

- Realize unparalleled low power consumption through optimization of CPU core and processes

Power consumption/performance comparison (uA/DMIPS)

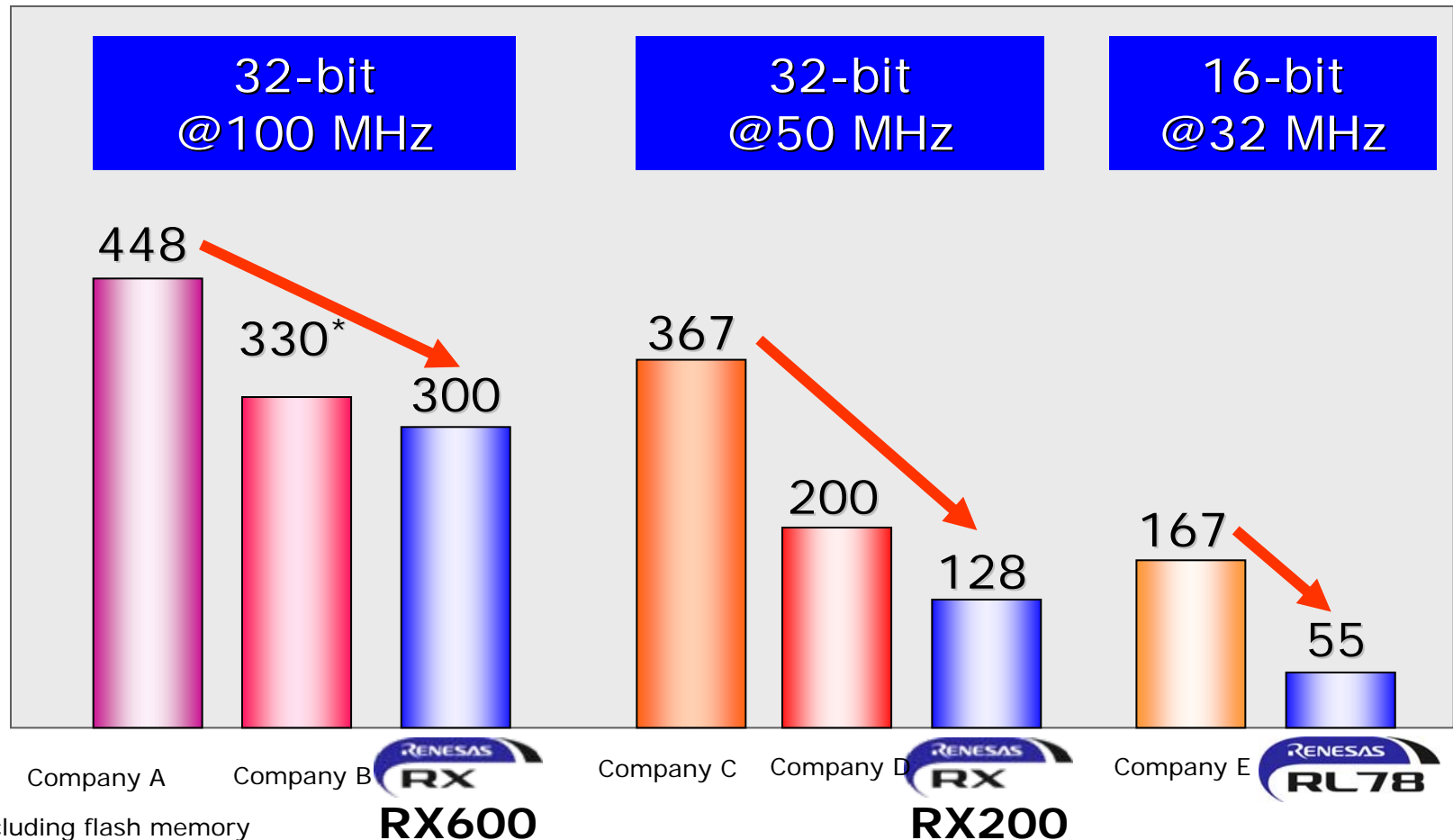

* Excluding flash memory

Promotion of Integrated Support Tools

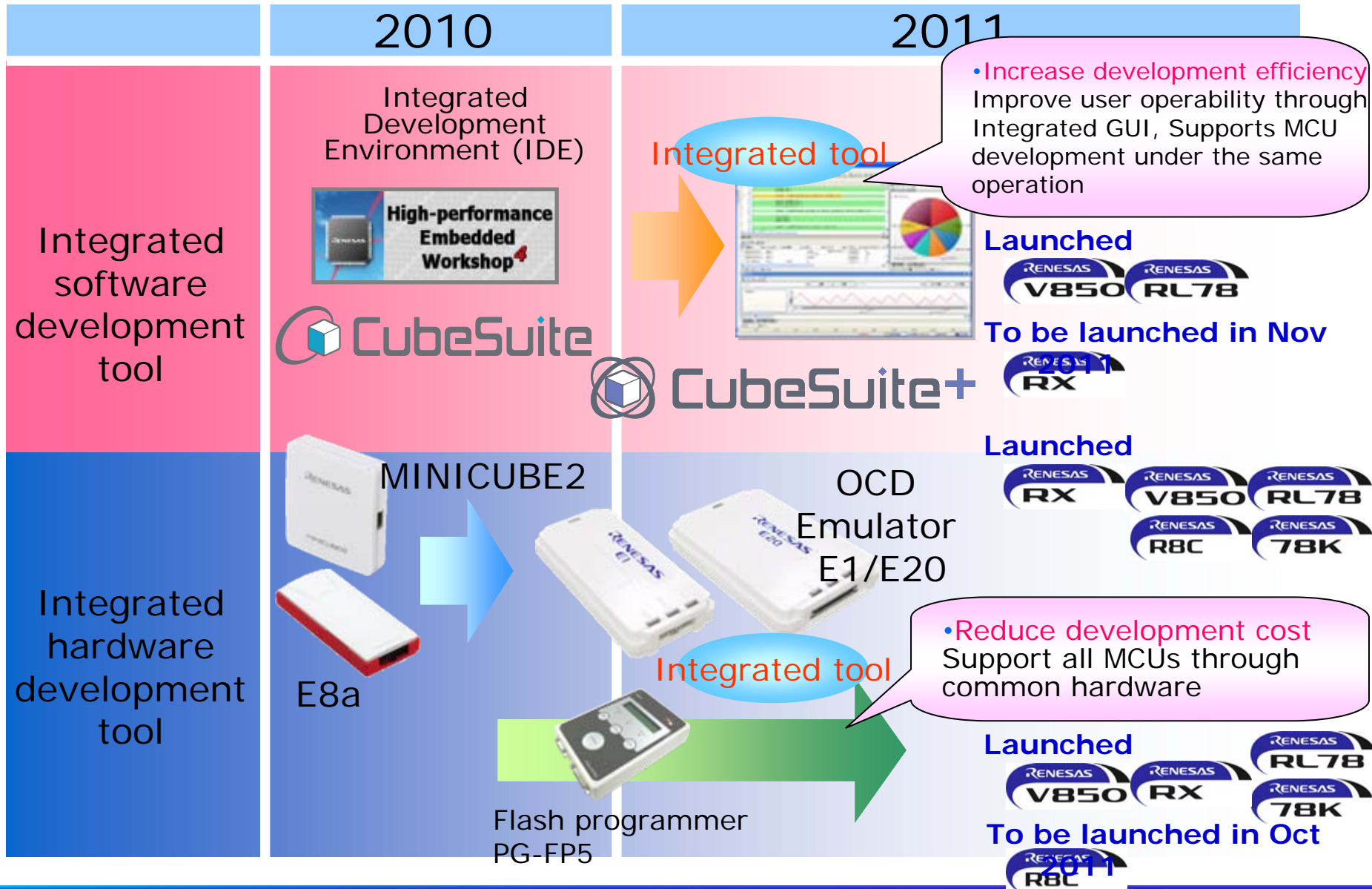

Support Structure

- Provide fine-tuned support as a semiconductor company in cooperation with partner companies
- Extensive alliance with over 700 partner companies worldwide



Provides customers with wide range of solutions including products and services from numbers of partners that provide services or products that support Renesas products and customers

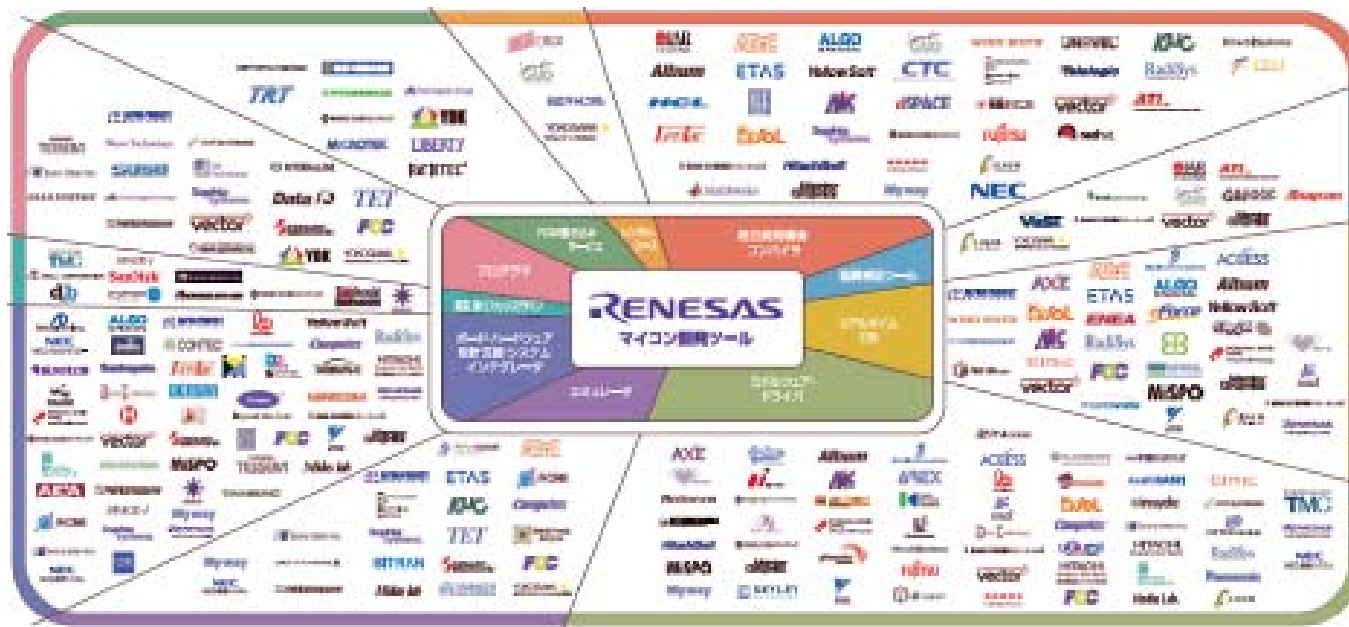

Global Network

- Construct a network on a global basis for sales, marketing, technology development

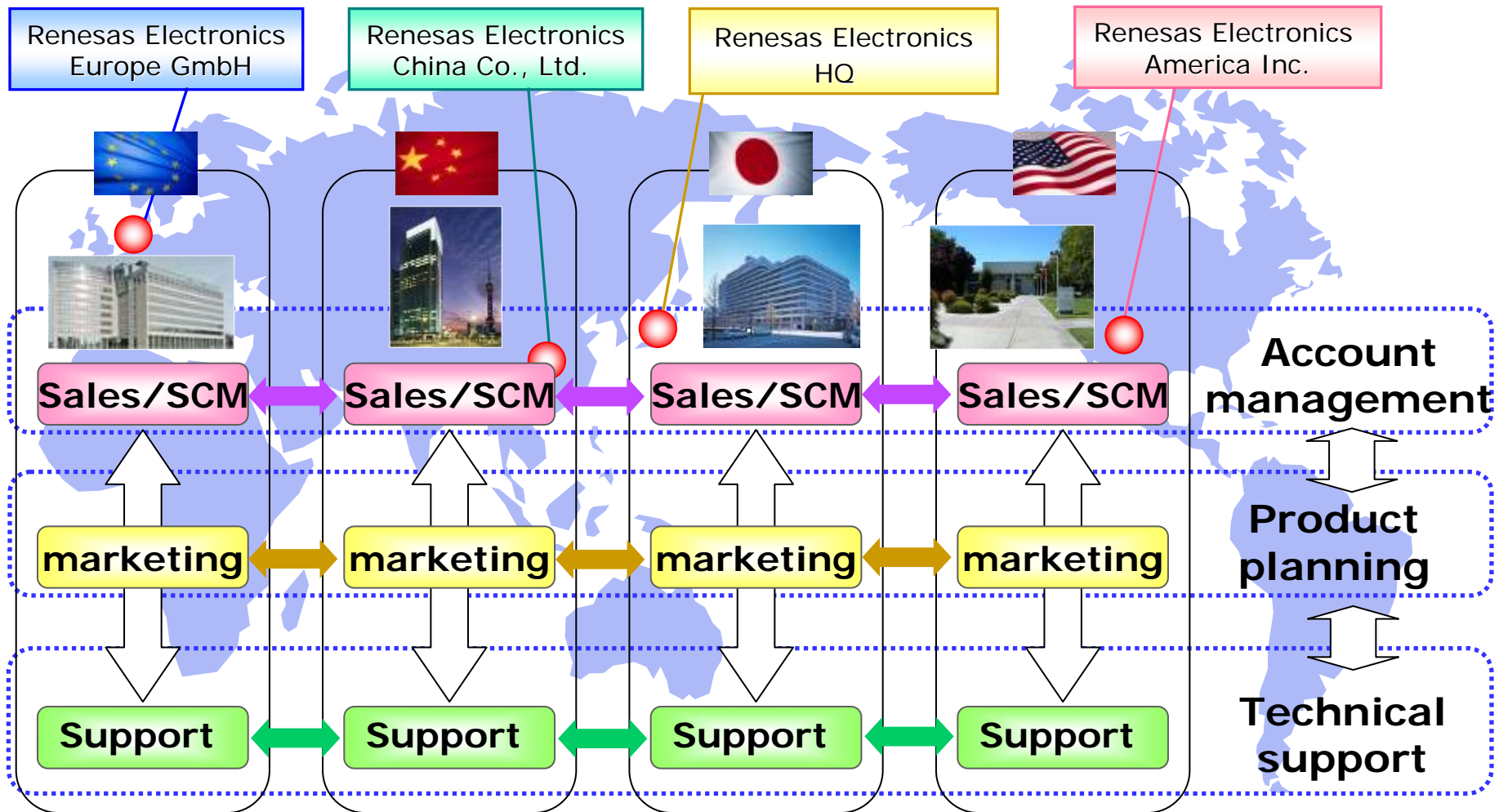

*Automotive organization

Target to Grow with Higher Rate than the Market

- Realize further growth in the global market, emerging countries and "Smart Society" by utilizing Renesas' overwhelming strength on MCU. Aim to expand market share at a growth rate exceeding that of MCU market

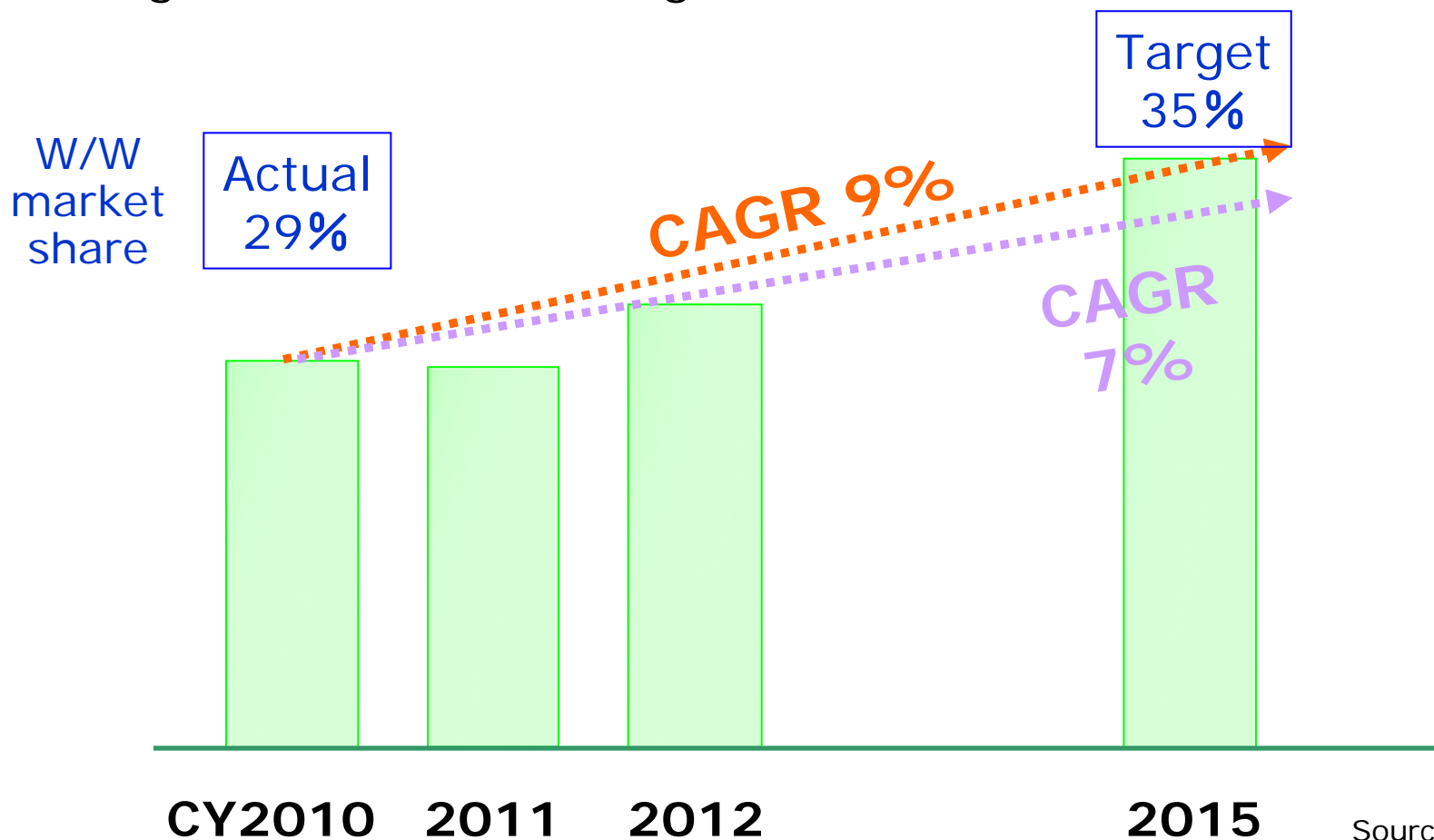

Source: Renesas

2. Business Policy by Business Segment (2) Analog & Power Business

Overview of Analog & Power Business

- Low-loss power device, and highly-integrated analog ICs realize energy-efficient and compact system

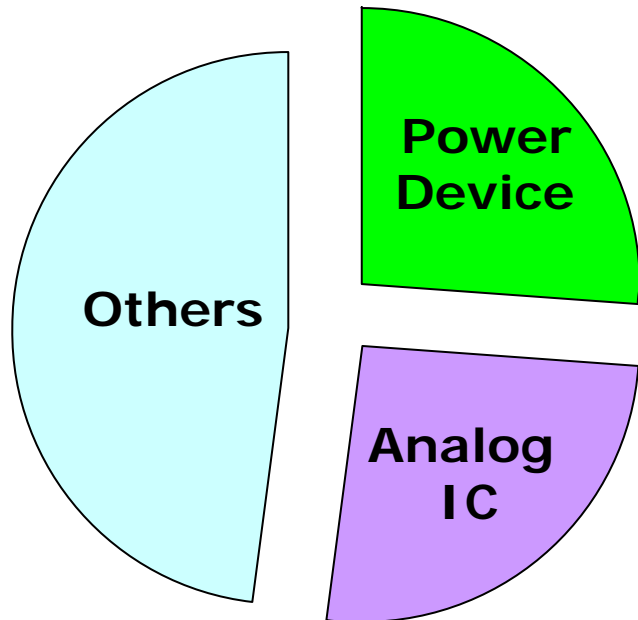

Power Device

- Power devices such as MOSFET and IGBT
- Market share: 7.4% (5th) (Note: including IGBT module)

Analog IC

- Analog ASIC/ASSP for automobile
- Market share: 3.9% (5th)

Source: Renesas, iSuppli (CY10)

Power device (Low voltage/high voltage power MOSFET, IGBT, Triac/SCR, IPD)
Analog IC (Analog ASIC/ASSP, General-purpose linear IC, High-frequency IC)
Others (Diode, Photocoupler, General-purpose SRAM, EEPROM, LCD driver, etc.)

Renesas' Power Device

- Extensive product lineups ranging from low-voltage to high-voltage (up to 2,000V) contribute to offering wide range of highly-efficient systems

Demand forecast of power device (excl. module)



Adding to world's No.1 low-voltage power MOSFET, Renesas will enhance the high-voltage MOSFET and IGBT lineups with such technology as trench filling epitaxial, and ultra-thin wafer process

Total power device will grow by 7% annually driven by high-voltage power device such as IGBT

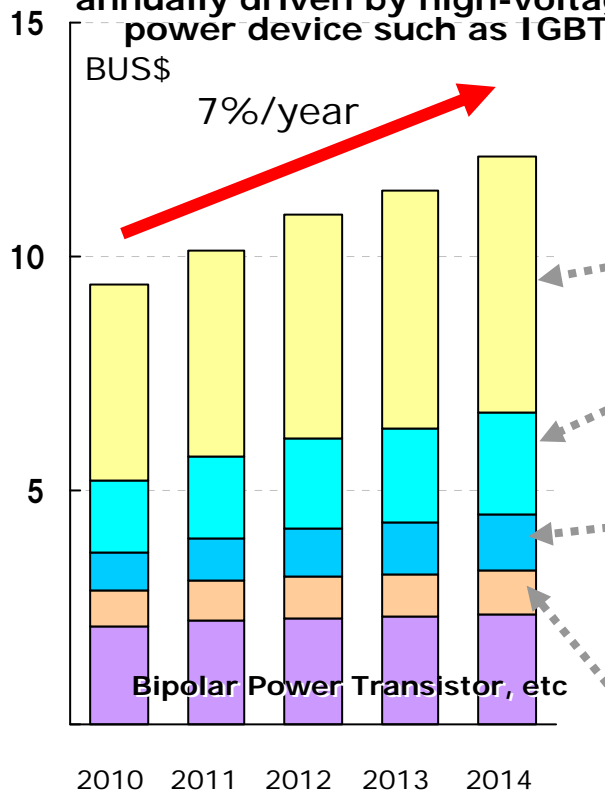

	CAGR (10-14)	CY10 Market ranking (Share)	Application	
Low-voltage Power MOSFET	+7%	1st* (15%)	Automotive device, PC/server, rechargeable battery	Keep
High-voltage Power MOSFET	+9%	6th* (7%)	Power supply module	Enhance
IGBT (excl. module)	+11%	4th* (9%)	White goods, Digital AV device, Strobe	Enhance
Triac/Thyristor	+5%	3rd* (14%)	White goods, Power supply module	Enhance

2010 2011 2012 2013 2014
Excluding power diode

Source: WSTS

Renesas' Low-Voltage Power Device Technology

- Low on-resistance, fast switching speed and space-saving packaging to attain high efficiency and more compact systems

MOSFET for battery

Established excellent record with world's smallest chip

MOSFET for mobile phone

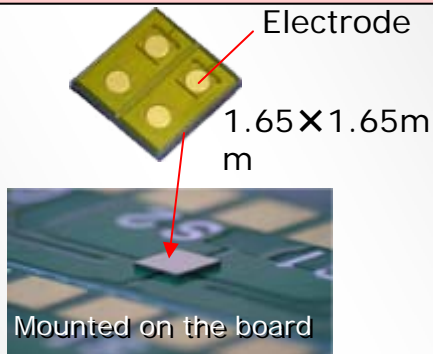

SVR solution for power supply of PC and server

Energy-saving, space-saving and easy evaluation

High-performance one-chip controller with built-in MCU

+

Highly-efficient power device Dr.MOS

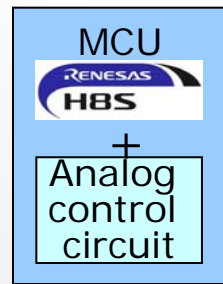

(5x5-mm)

Driver+MOSFETx2 in 1 package

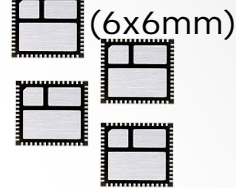

Optimized Power control



Easy evaluation

SVR: Scalable Voltage Regulator



Power device for automobile

Automotive MOSFET

Address wide range of needs from compact package to large-current bare die



IPD (Intelligent Power Device)

Switching device with integrated protection function

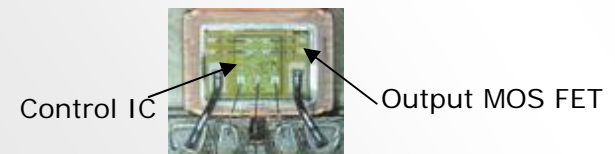

Renesas' Power Device Technology Realizes High-efficiency Inverter

- Trench-filling epitaxial technology, ultra-thin wafer process technology and space-saving packaging yield more compact systems with high efficiency

High-voltage MOSFET (Over 200V)

Deep trench (50 micron)

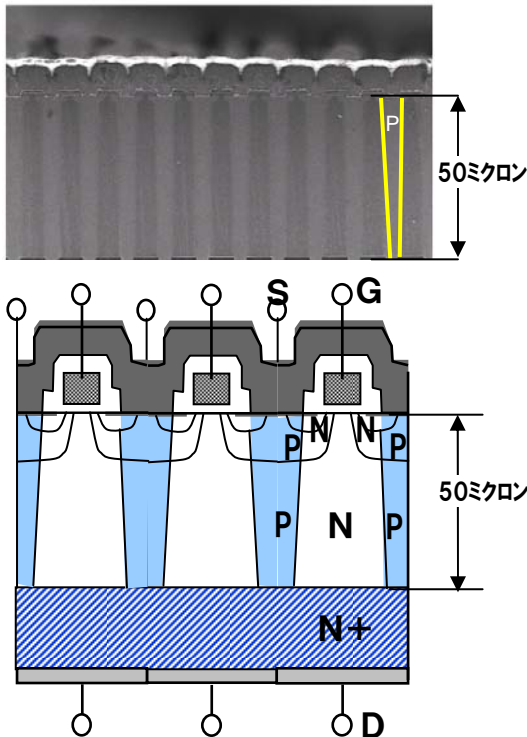

IGBT

(Excluding module)

Thin wafer (70 micron@8-inch)

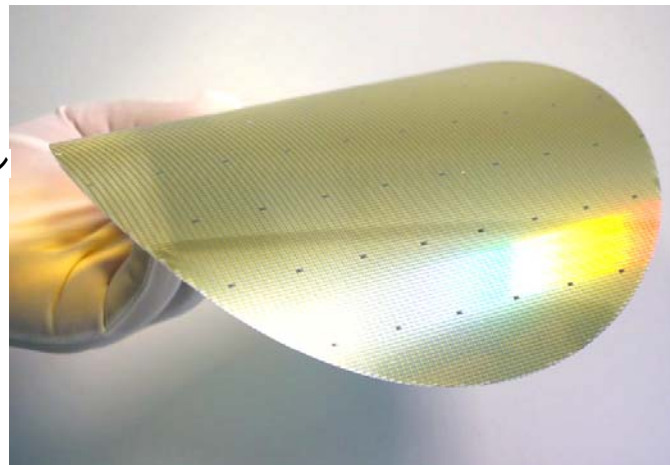

FRD Diode FRD: First Recovery Diode

Integrates the newly-adopted SiC and compound IGBT in a single package

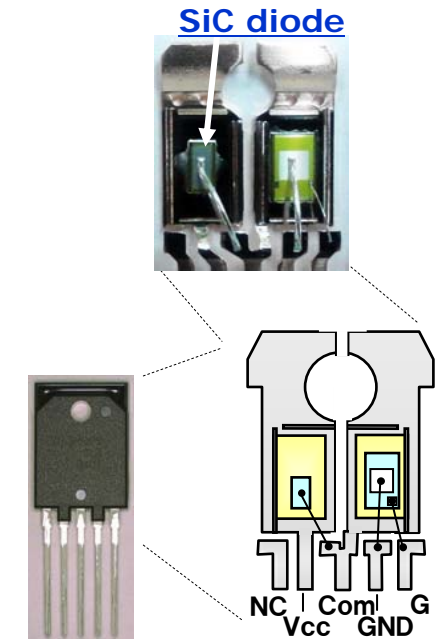

Enhance Product Lineups of High-voltage Power Devices

- Inverters as the key driving force for growing power devices
- Enhance product lineup covering up to 1,800V centering around power devices for inverter control

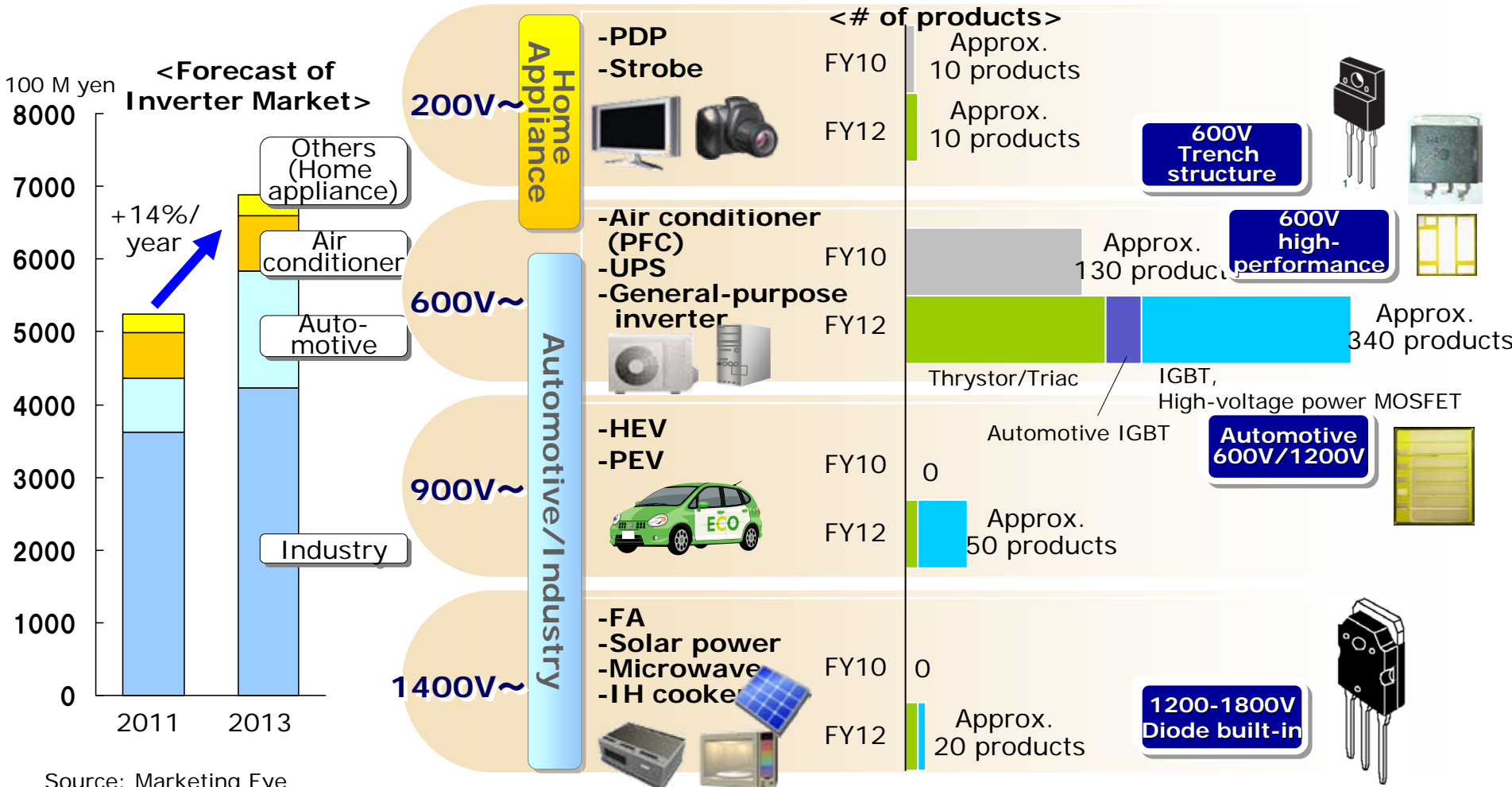

Source: Marketing Eye

Renesas Analog ASIC/ASSP Products

- Optimally-designed by system needs, realizing a compact system with high functionality

Analog IC market

- Market of analog ASIC/ASSP accounts for 60% of the whole analog market
- Renesas has a proven record centering around automotive, consumer and PC areas with approx. 4% market share and is ranked in the 5th place

Analog ASIC

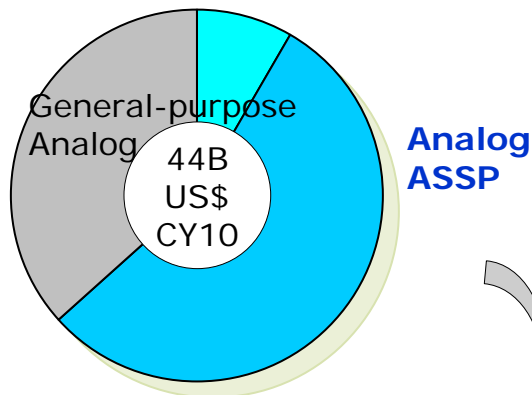

- Business expansion through automotive analog ASSP as well as automotive ASIC
- Providing battery-control solution of MCU together with analog ASSP for cloud-computing terminals, such as smartphones and tablet PC, etc

Analog ASIC/ASSP market

	CAGR (10-15)	CY10 Market ranking (Share)	Major product
Automotive	+9%	5th* (9%)	Body control, Engine control, Communication interface
Consumer	+3%	3rd** (8%)	DSC lens control, LED driver, PFC***
PC	+3%	4th** (6%)	Motor driver, Battery control

Enhance

Keep

Keep

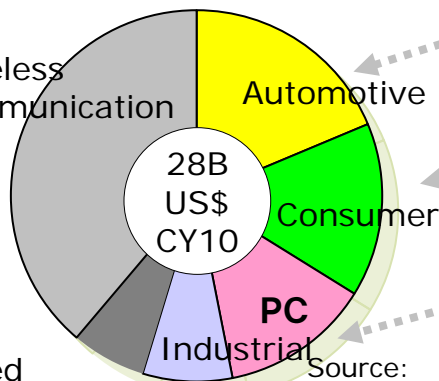

Source: Renesas, iSuppli

***PFC: Power Factor Correction

Source: * Strategy Analytics, ** iSuppli, Renesas

Automotive Analog ASIC/ASSP

- Automotive systems require sensor inputs, and mechanical control, and thereby makes analog IC a key component
- Needs for uniting peripherals with analog IC as a core to realize compact and highly-integrated system

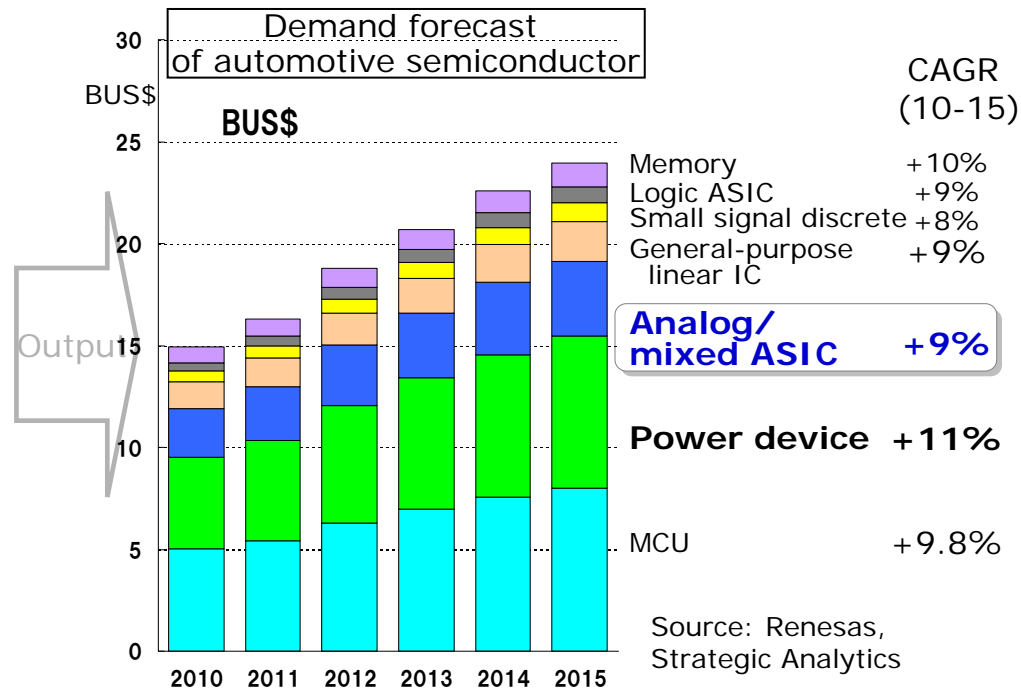
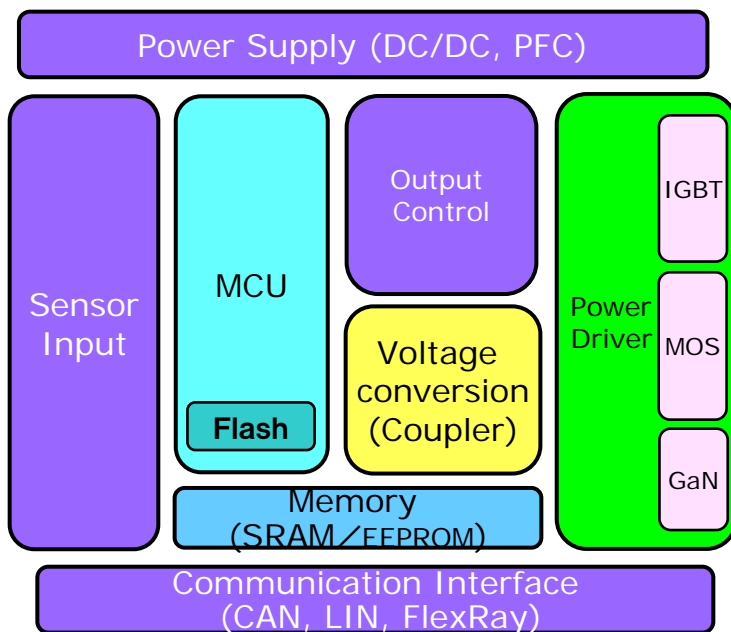

As the world's leader of automotive semiconductor, Renesas has established a significant presence in all three areas, including MCU, analog IC and power devices.

Market share	Automotive Semiconductor	Automotive MCU	Automotive Analog IC	Automotive Power MOSFET
	#1*	#1*	#5*	#1**

Automotive Analog IC: Expand to ASSP in Addition to ASIC

- Adding ASSP business based upon the rich experience of automotive analog system technology of ASIC

Automotive analog system technology

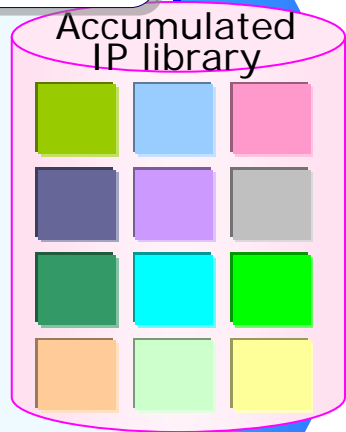
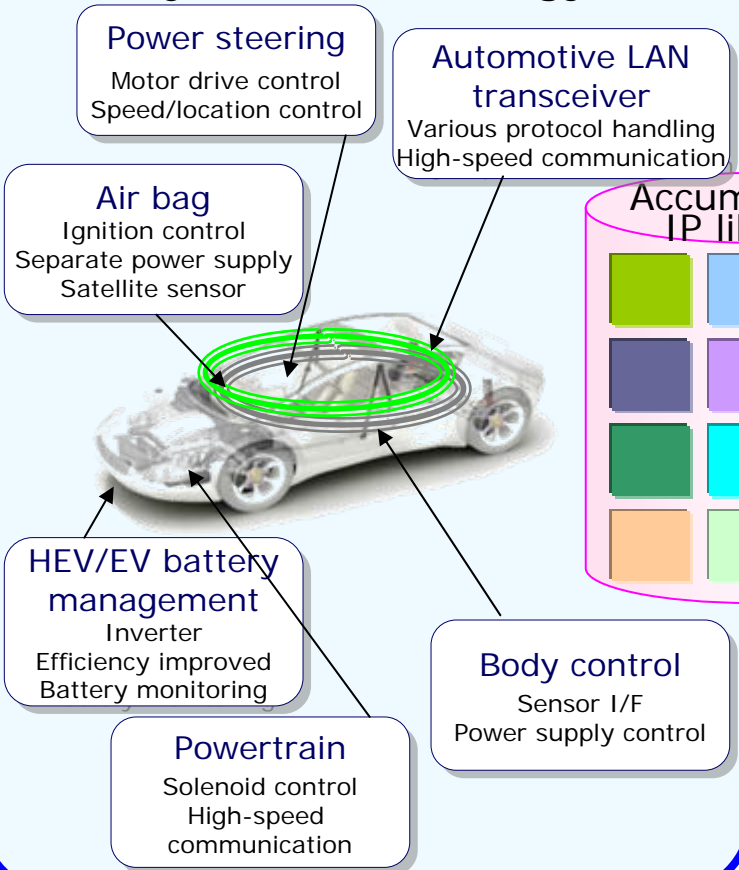

Analog ASSP

"Contribute to low-power, down-sized, safety design of automotive system"

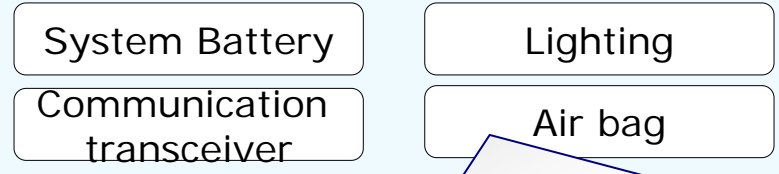

ASSP solution case for products supporting air bag

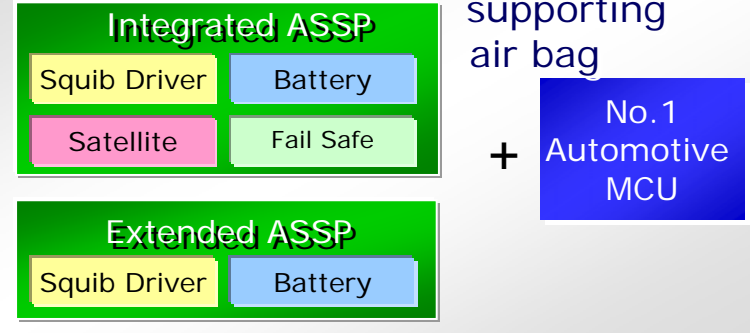

Analog ASIC

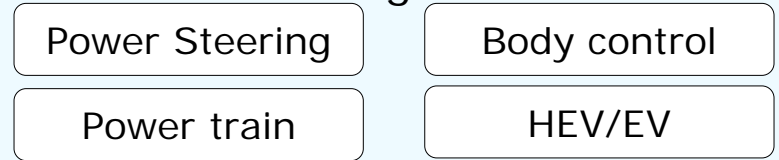

Provide Battery Management Solutions for Cloud Terminals

Forecast for Market scale in 2015: Approx. 38BUS\$

Battery monitor/control

With total technology of MCU+Analog IC (+firmware), apply knowhow of laptop PC to smart phone and tablet PC and provide best solutions for high performance battery control

Long-lived battery technology

- Precision analog circuit technology ($\Delta\Sigma$ ADC)
- Precision battery failure prediction algorism

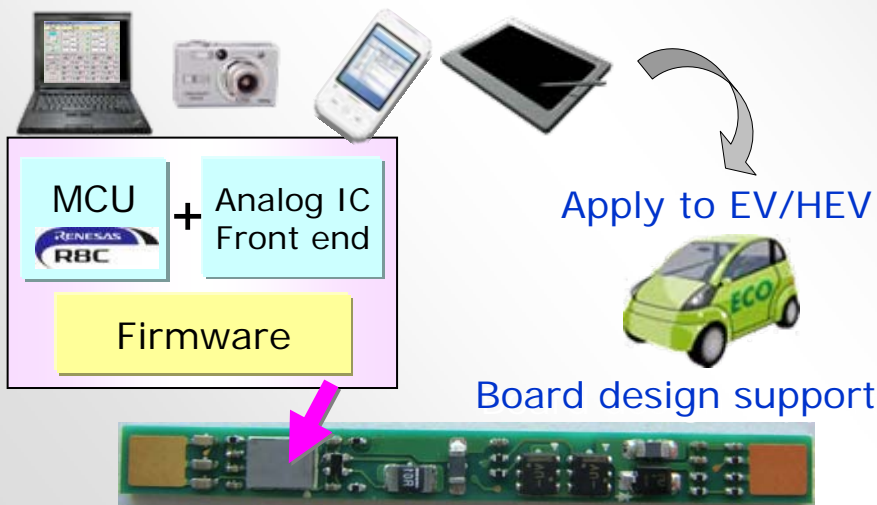

Wireless charging system

Provide solution combining MCU and analog IC

Technology for wireless power supply system

- High-efficiency/low-noise power supply technology
- RF technology
- Protocol control/authentication/safety control

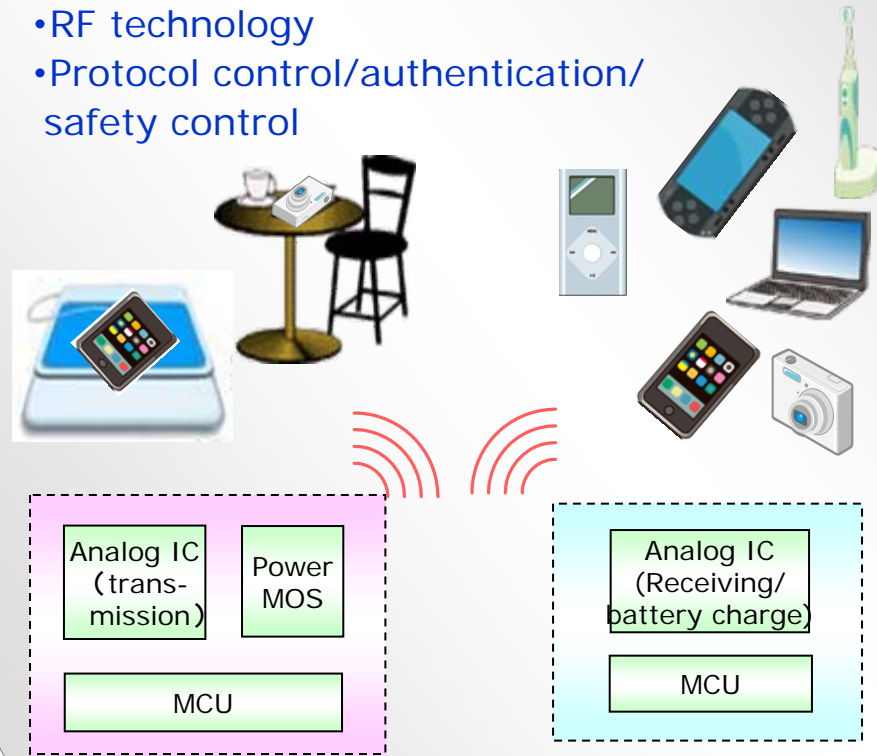

Target Market Share

CY2010

CY2015

Power Device

1st	11%
2nd	9.2%
3rd	8.4%
4th	7.9%
5th Renesas	7.4%

Over 10%

Analog IC

1st	11%
2nd	9.0%
3rd	6.7%
4th	6.6%
5th Renesas	3.9%

Over 5%

Source: Renesas, iSuppli (CY10)

2. Business Policy by Business Segment

(3) SoC Business

SoC Business Domain and Policy

Core devices for cloud-computing infrastructure

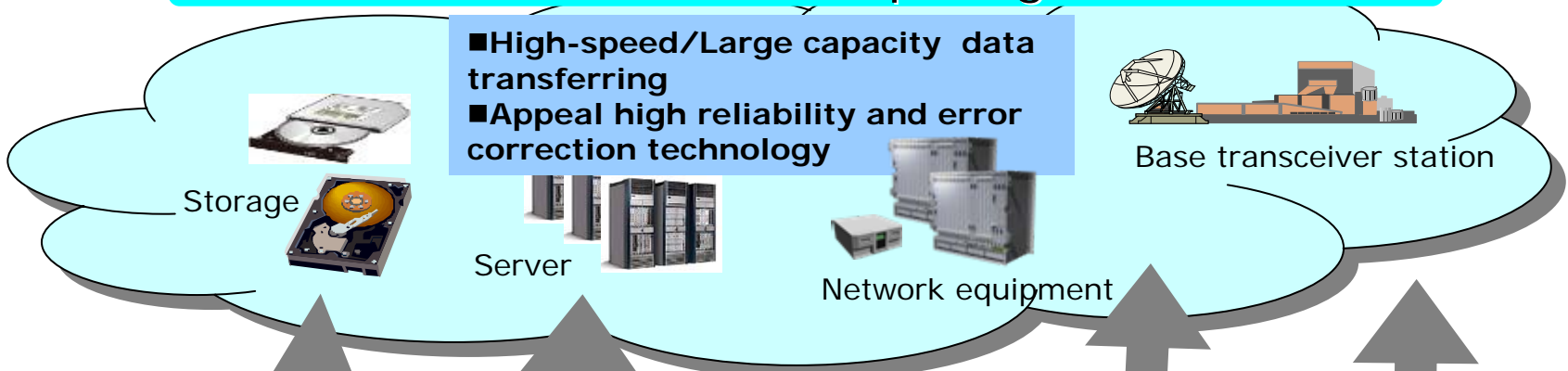

Highly-reliable, real-time Ethernet communication

Communication Via power line

Encryption

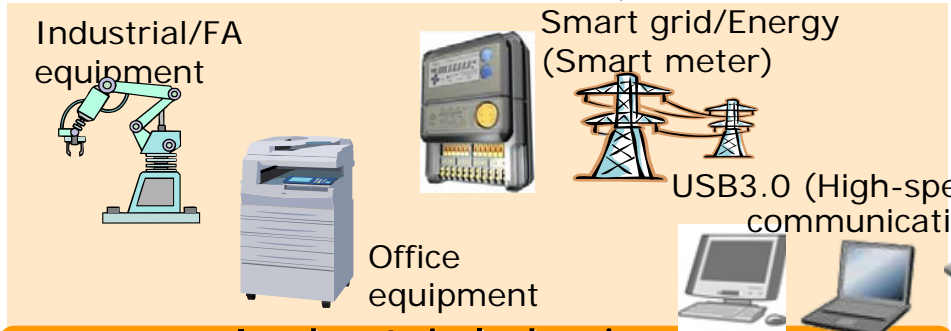

Industrial devices for cloud-computing



Multimedia cloud terminal

Cloud infrastructure

Terminal (Client)

- Real-time Ethernet
- PLC
- USB3.0, etc.

Provide silicon solutions that boast competitive interconnect technology with cloud-computing systems

- High-speed wireless communication
- Cryptographic communication

Strengthen interconnect technology with cloud-computing systems and provide system solutions

Provide SoCs for Core Equipment of Cloud Infrastructure and Industrial Equipment

- Steadily expand business by providing silicon solutions for core equipments of cloud infrastructure and for industrial equipments
- Streamline consumer products of short lifecycle



Address the needs for high-performance, highly-reliable and differentiated products for infrastructure and industrial equipment

Fine-tuned WW network of sales and design

Design platform for custom LSI

Rich IP lineup for industrial and communication

Low power technology (Green Technology)

High quality and reliability

Long-term stable production

Focus on STB in the Era of Cloud Computing

- Propose and expand new STB for pay-per-view TV service with rich cryptographic technology for/via service operator and provider integrating communication, broadcasts and internet

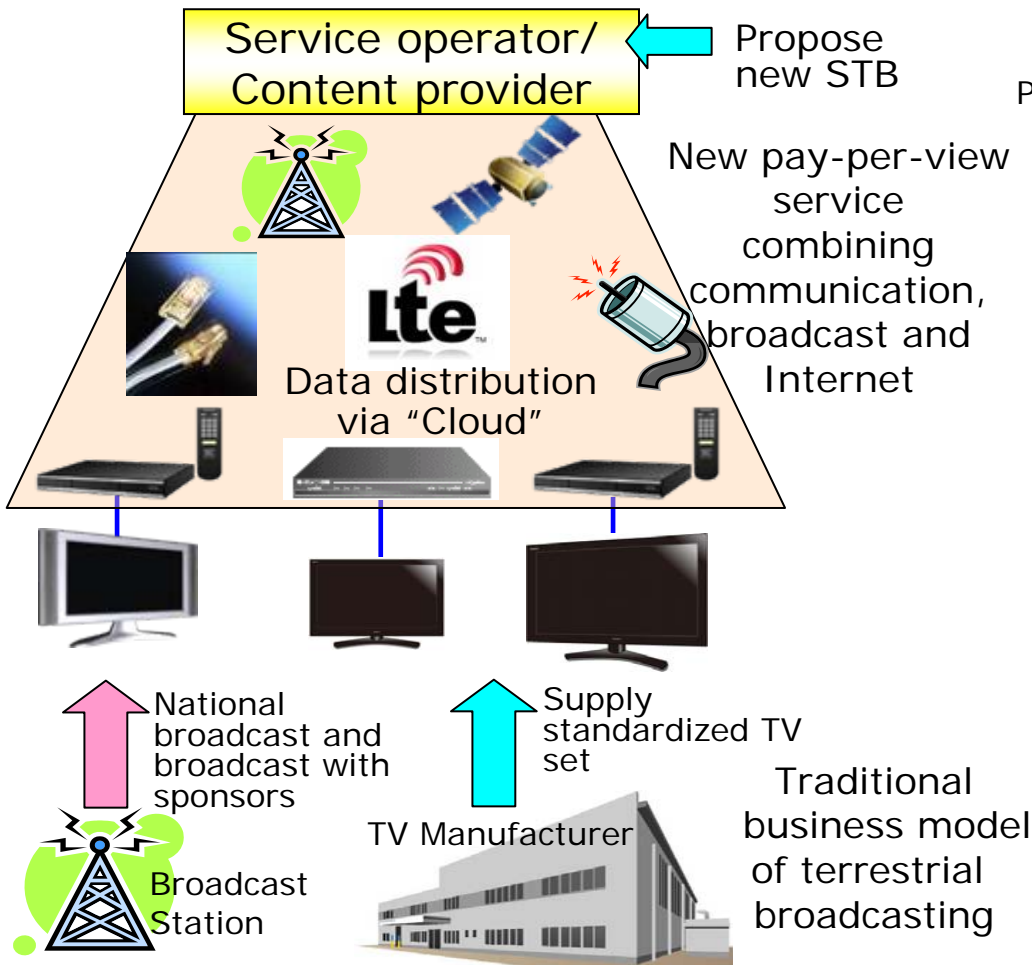

Traffic forecast of Internet video

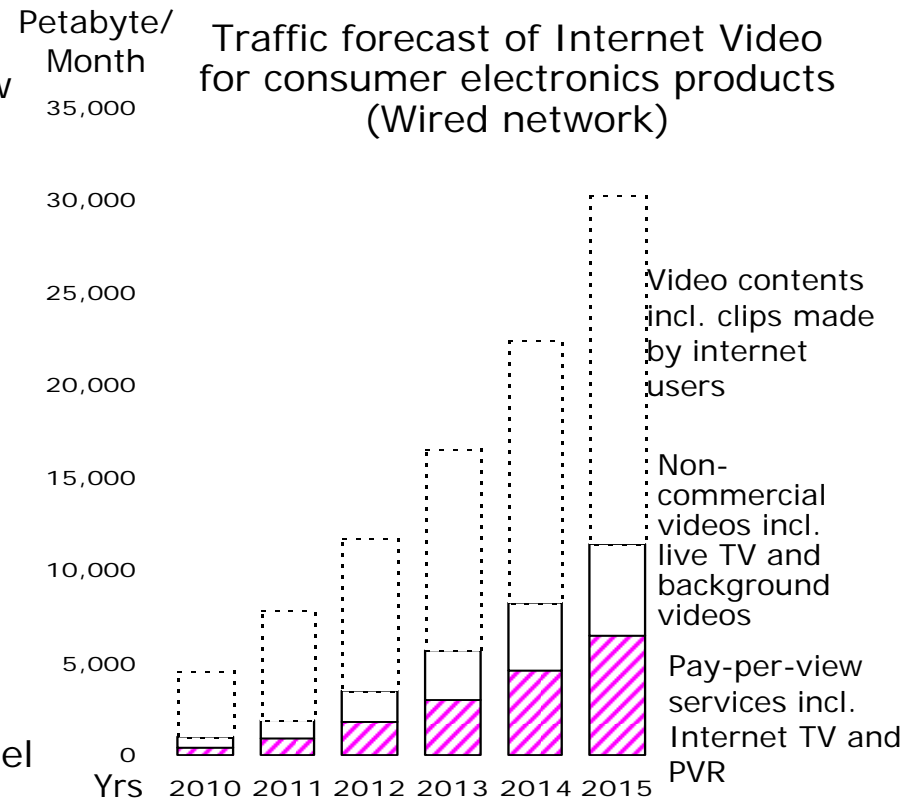

Source: Cisco (Cisco Visual Networking Index: Forecast and Methodology, 2010-2015)

Renesas Mobile Business Strategy – Necessary Conditions to Win in the Market

Application technologies



No.1 track record in Japan

OS Technologies



Support Android 2.3

Modem technologies



World's smallest LTE chip

Reference design



LTE data card

SoC



- Application processor
- RF IC
- Modem baseband



Android smartphone

Customers W/W

Business Strategy of Renesas Mobile

– Sufficient Condition to Win

- Long-term partnership with third-party companies is essential to provide mobile platform
- Only Renesas Mobile and other few companies have experience of broad partnership

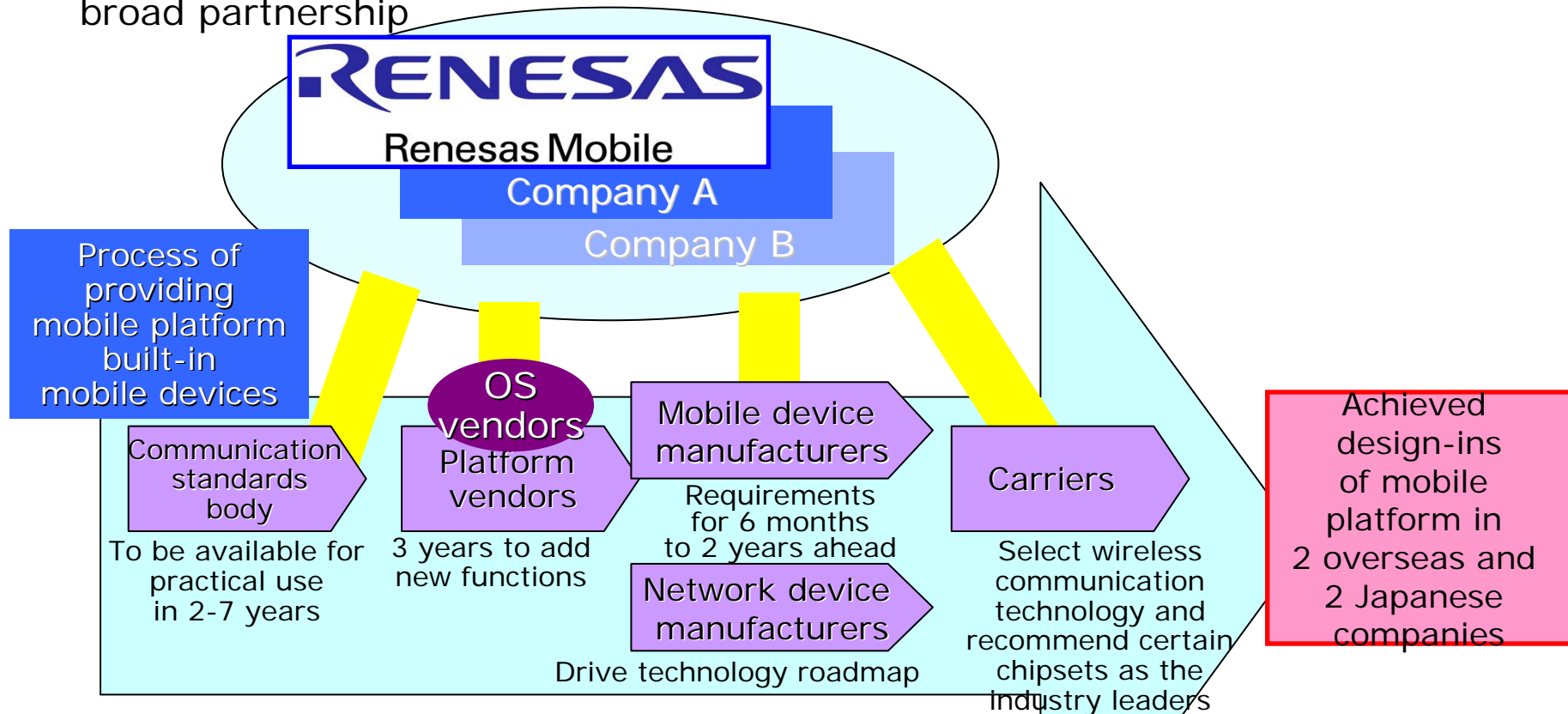

Essential to establish a close, long-term partnership with third parties in order to incorporate advanced technology into mobile platform and to get that mobile platform adopted to network and mobile devices

3. Business Continuity Plan (BCP)

Renesas' New BCP

- Aim to improve strength for business continuity to prioritize keeping stable product supply to customers

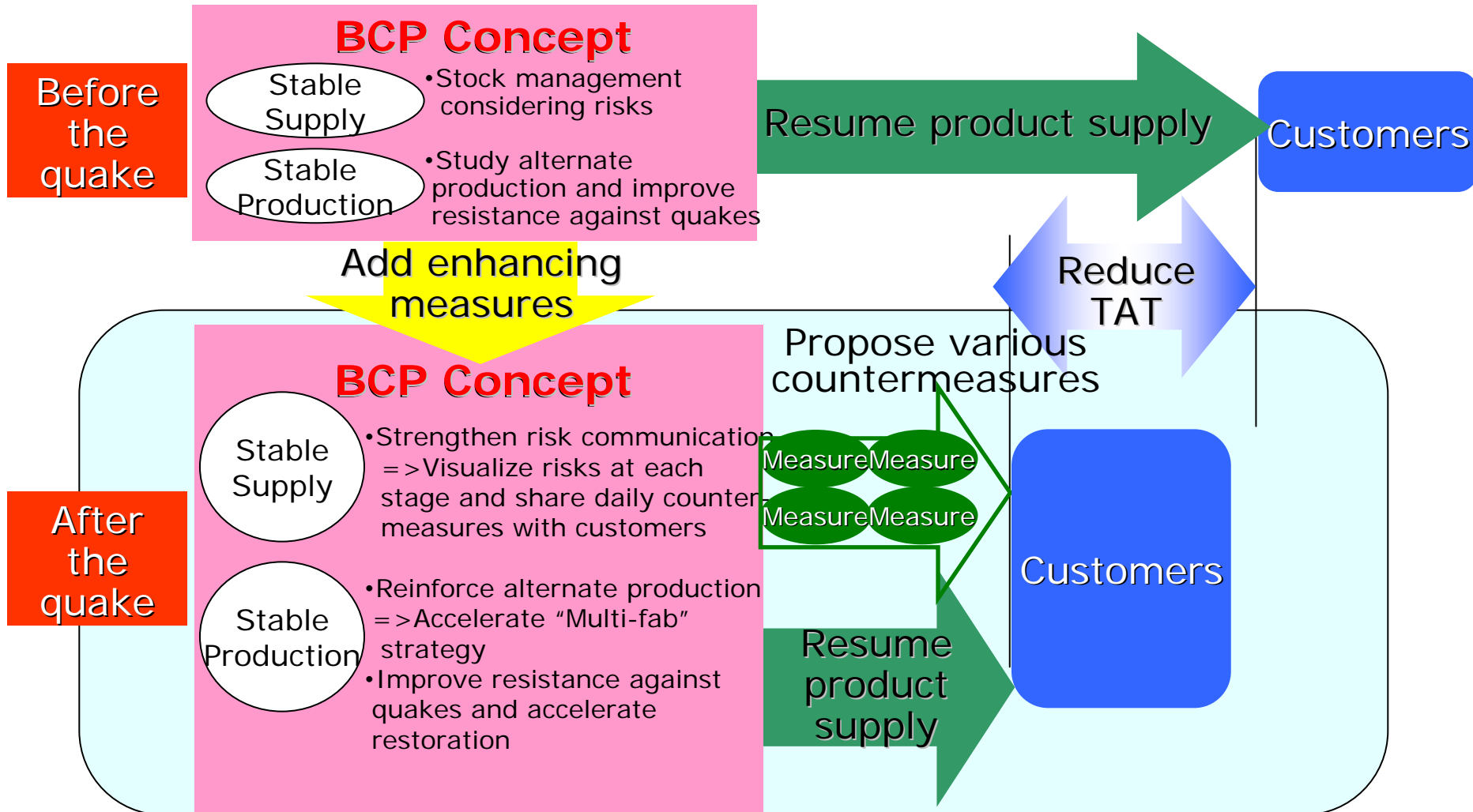

Approach to Reduce Damages to Minimum Level

- Build robust factories by enhancing earthquake resistance and countermeasures for quick recovery

■ Enhance earthquake safety

- Resistant to intensity 6 lower → Strengthen to 6 upper
(same level as the Great East Japan Earthquake)
- Target to resume production within one month for front-end lines and within 0.5 month for back-end lines

■ Countermeasures for quick recovery

- Clarify the points which took time to restore due to great damages

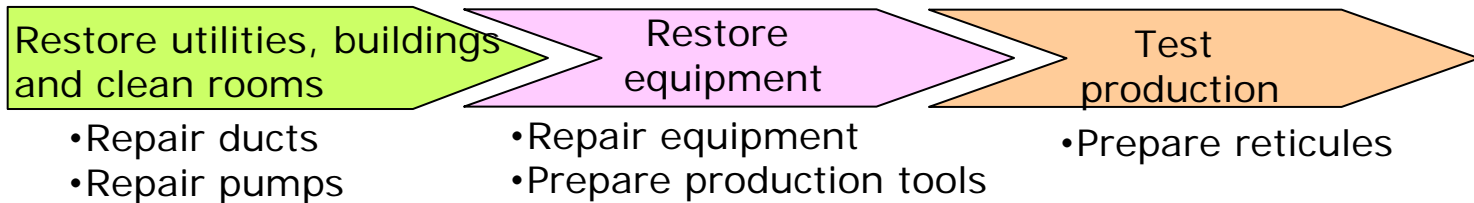

- Improve mainly the points above which we learned from the earthquake to resume production earlier

More robust and easier-to-recover
Manufacturing facilities

Accelerate the “Fab Network” as Part of Stronger BCP

- “Fab network”, which has been promoted through the 100-Day project, is the most effective countermeasures against earthquake
- Full-effort to accelerate establishment of “fab network” to ensure further reliability to customers

Customers requests

- Multi-fab (more than two factories available for mass-production)
- Continue to offer high quality through alternate production (multi-fab production)

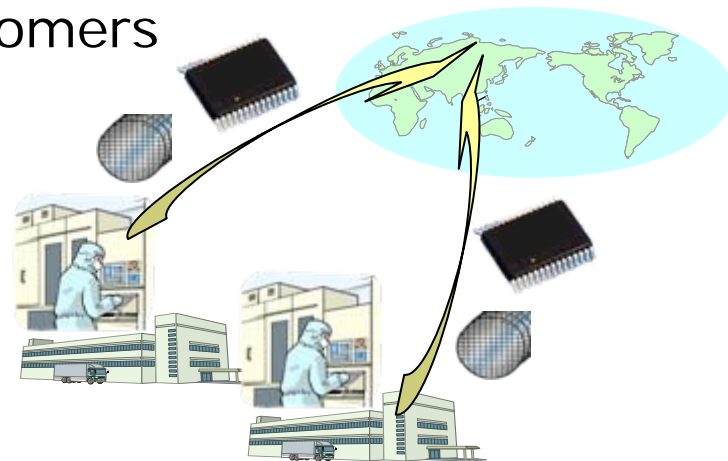

Renesas countermeasures

- Accelerate establishment of fab network, including multi-fab, which has been planned and promoted since the 100-Day project
 - For core **MCU business** aims to establish a structure which enables production of **more than 90%** of Renesas' MCU products (below 0.15 μm) to be done at alternate manufacturing sites upon customers' approval (achieved for 80% of MCU products at present)
- Establish a system which enables multi-fab more smoothly by streamlining production process of system analog and others

Example of “Multi-Fab” Approach for MCU Products

Process node	Process technology	Current fab/line	Alternate fab/line	Time frame
0.15 μ m	RC01F	Naka/200mm	Naka/300mm, Foundry	Mass production now
	RC01S	Saijo/200mm	Naka/300mm	Mass production now
	MF2	Kawashiri/200mm	Foundry, (Shiga)	Mass production now, (FY12)
	MF3	Kawajiri/200mm	Shiga, Foundry	FY13
90nm	RC03F	Naka/300mm	Yamagata, Foundry	FY12
	UX6LF	Yamagata/300mm	Naka/300mm	FY13
65nm	RC04LP	Naka/300mm	Foundry	1H/FY11
40nm	RV40F	Naka/300mm	Yamagata, Foundry	FY13

*Foundry: GLOBALFOUNDRIES, TSMC, Telefunken Semiconductors (Roseville factory)

Approach to “Multi-Fab” for A&P Products

Process-node	Process technology	Current fab/line	Alternate fab/line	Time frame
10 μm	TRIAC	Takasaki/150mm	Foundry	FY12
0.5 μm	BCD	Kochi/150mm	Saijo/200mm	2H/FY12
0.35 μm	Automotive IGBT	Kofu/200mm	Shiga/200mm	FY12
	Automotive Analog	Naka/200mm	Takasaki/150mm	Mass production now
0.18~ 0.2 μm	APEX	Kofu/200mm	Foundry	FY12
0.15 μm	BEAM2	Kofu/200mm	Shiga/200mm	2H/FY11
	BCD	Saijo/200mm	Foundry	TBD
0.13 μm	C130L	Powerchip	Naka/300mm	Mass production now
90nm	90nmHV	Powerchip	TSMC	1H/FY12

Approach to Stable Supply

- Promote visualization of risks and provide tailored various options to customers

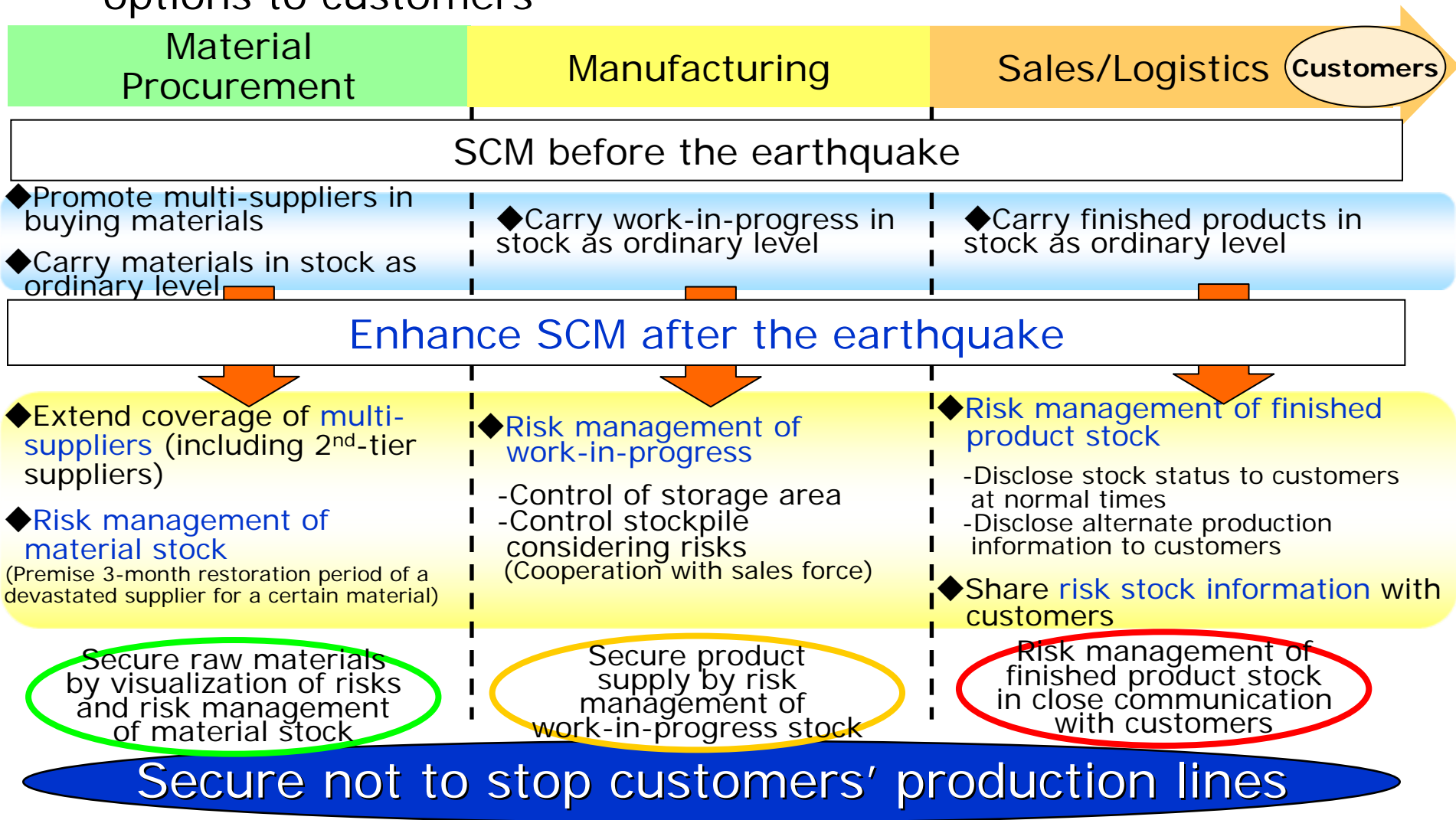

4. Summary of Business Policy

Target Business Structure

Accelerate focusing on MCU and A&P businesses

- ✓ Continue to expand Renesas' world No.1 MCU business for **smart society and emerging countries**
- ✓ Further expand MCU and A&P businesses with synergy among MCU, Analog IC and power device as the main pillar for achieving profits
- ✓ Drastically sort out core competence in the SoC business and focus on markets related to society- and industrial-infrastructure and cloud computing

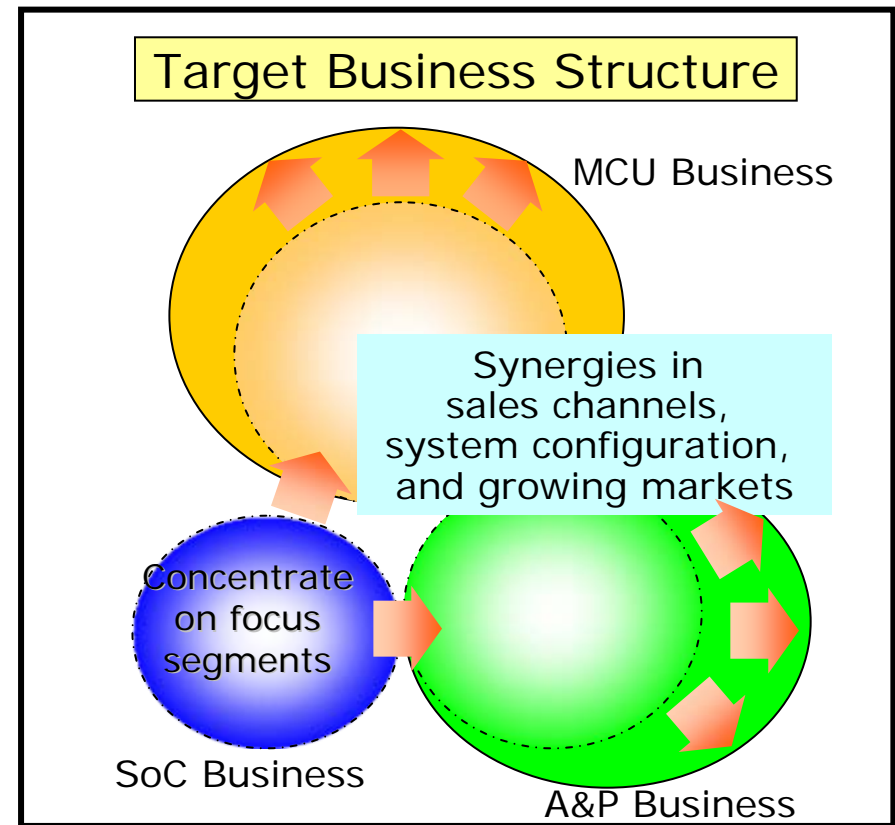
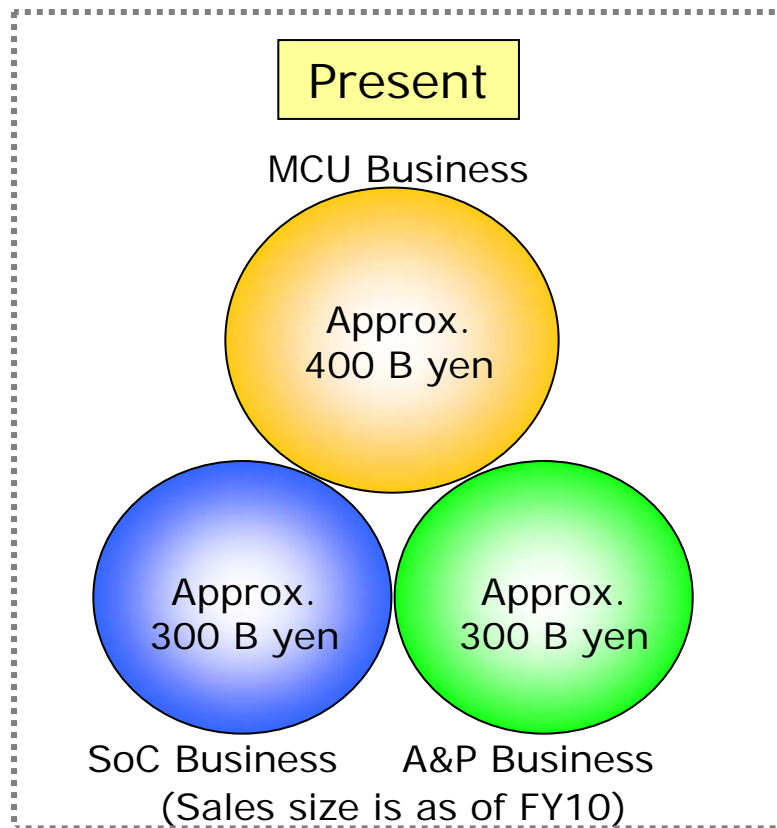

Path to Target Business Structure

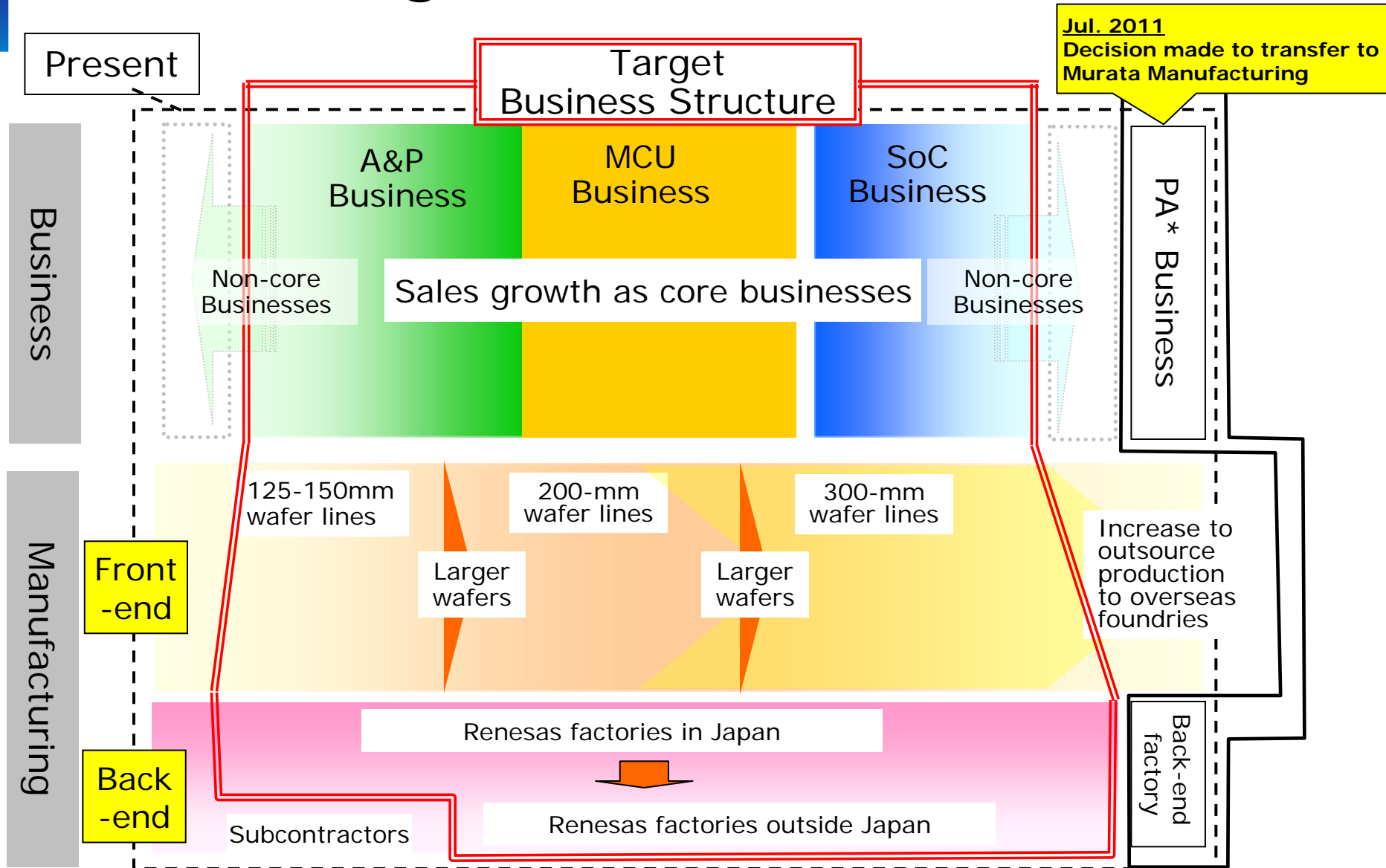

*PA: Power Amplifier

Target Management Index

Ratio to Sales	FY2011		Mid-term target
Operating Profit Ratio	-3%	<ul style="list-style-type: none"> ➤ Transformation of business structure 	<i>Over 10%</i>
Gross Profit Ratio	32%	<ul style="list-style-type: none"> -Strengthen core businesses -Accelerate withdrawal from non-core businesses -Manufacturing realignment 	<i>Approx. 40%</i>
R&D Ratio	20%		<i>Approx. 16%</i>
SG&A Ratio	15%	<ul style="list-style-type: none"> ➤ FY2012 Full-year -Achieve operating profit -Achieve net profit 	<i>Approx. 14%</i>

(FOREWARD-LOOKING STATEMENTS)

The statements in this presentation with respect to the plans, strategies and forecasts of Renesas Electronics and its consolidated subsidiaries (collectively “we”) are forward-looking statements involving risks and uncertainties. We caution you in advance that actual results could differ materially from such forward-looking statements due to several factors. The important factors that could cause actual results to differ materially from such statements include, but are not limited to: general economic conditions in our markets, which are primarily Japan, North America, Asia and Europe; demand for, and competitive pricing pressure on, our products and services in the marketplace; our ability to continue to win acceptance of its products and services in these highly competitive markets; and movements in currency exchange rates, particularly the rate between the yen and the U.S. dollar. Among other factors, a worsening of the world economy; a worsening of financial conditions in the world markets, and a deterioration in the domestic and overseas stock markets, would cause actual results to differ from the projected results forecast.



Renesas Electronics Corporation

© 2011 Renesas Electronics Corporation. All rights reserved.