



Integrated Device Technology, Inc.
6024 Silver Creek Valley Road, San Jose, CA - 95138

PRODUCT/PROCESS CHANGE NOTICE (PCN)

PCN #: A1804-01 DATE: 18-Apr-2018 Product Affected: TSE2004GB2C0NCG TSE2004GB2C0NCG8 Date Effective: 18-Jul-2018	MEANS OF DISTINGUISHING CHANGED DEVICES: <input type="checkbox"/> Product Mark <input type="checkbox"/> Back Mark Assembly lot# prefix: <input type="checkbox"/> Date Code "TF" denote TFME, China <input checked="" type="checkbox"/> Other "HT" denote HTC, China
--	---

Contact: IDT PCN DESK E-mail: pcndesk@idt.com	Attachment: <input checked="" type="checkbox"/> Yes <input type="checkbox"/> No Samples: Please contact your local sales representative for sample request.
---	--

DESCRIPTION AND PURPOSE OF CHANGE:

<input type="checkbox"/> Die Technology <input type="checkbox"/> Wafer Fabrication Process <input type="checkbox"/> Assembly Process <input type="checkbox"/> Equipment <input type="checkbox"/> Material <input type="checkbox"/> Testing <input checked="" type="checkbox"/> Manufacturing Site <input type="checkbox"/> Data Sheet <input type="checkbox"/> Other	<p>This notification is to advise our customers that IDT is adding TFME, China and HTC, China as alternate facilities for Assembly, Test and Backend process for the select product. Current Assembly, Test and Backend location is Carsem, Malaysia.</p> <p>Attachment 1 details the change.</p>
--	---

RELIABILITY/QUALIFICATION SUMMARY:

There is no expected change to the product quality or reliability performance.

CUSTOMER ACKNOWLEDGMENT OF RECEIPT:

IDT records indicate that you require written notification of this change. Please use the acknowledgement below or E-Mail to grant approval or request additional information. If IDT does not receive acknowledgement within 30 days of this notice it will be assumed that this change is acceptable.

IDT reserves the right to ship either version manufactured after the process change effective date until the inventory on the earlier version has been depleted.

Customer: _____	<input type="checkbox"/> <i>Approval for shipments prior to effective date.</i>
Name/Date: _____	E-Mail Address: _____
Title: _____	Phone# /Fax# : _____

CUSTOMER COMMENTS: _____

IDT ACKNOWLEDGMENT OF RECEIPT:

RECD. BY: _____ DATE: _____



PRODUCT/PROCESS CHANGE NOTICE (PCN)

ATTACHMENT 1 - PCN # : A1804-01

PCN Type: Manufacturing Site - Alternate Assembly, Test & Backend Location

Data Sheet Change: None

Detail Of Change:

This notification is to advise our customers that IDT is adding TFME, China and HTC, China as alternate facilities for Assembly, Test and Backend process for the select product. Current Assembly, Test and Backend location is Carsem, Malaysia.

This change will allow IDT the flexibility to ship from all the qualified facilities and will provide the increased capacity, flexibility and shorter lead time to meet market demand.

The material set details of the current and alternate assembly locations are as shown in Table 1.

There is no change to moisture sensitive level.

There is no change in the Test processing flows. IDT has completed the electrical test correlation and based on the test results we do not anticipate any impact on device performance. The testing is fully compatible and transferrable between the test facilities with no change to the test coverage.

The Backend process is standardized between the alternate sites. The carrier tape and plastic reel used in the alternate sites are with the same dimensions as used in Carsem Malaysia. There is no change to form, fit and functions.

If you require samples to conduct evaluations, please contact your local sales representative to acknowledge this PCN and request samples.

Table 1: Assembly Material Sets for The Existing and Alternate Assembly Locations

	Existing Assembly (Carsem, Malaysia)	Alternate Assembly (TFME, China)	Alternate Assembly (HTC, China)
Die Attach	EN4900GC	EN4900GC	8200T
Bond Wire	Gold wire	Gold wire	Gold wire
Mold Compound	CEL-9240HF10CS	CEL-9240HF10NF-B3	CEL-9240HF10NF-B3
Singulation Method	Sawn	Sawn	Sawn



Integrated Device Technology, Inc.
6024 Silver Creek Valley Road, San Jose, CA - 95138

PRODUCT/PROCESS CHANGE NOTICE (PCN)

ATTACHMENT 1 - PCN # : A1804-01

Qualification Information and Qualification Data:

Assembly Qualification Results

Affected Packages: VFQFPN-8
Assembly Material: Shown on page 2 of this attachment.
Qual Plan & Results: Tests are in accordance with JEDEC47 recommended tests.
Qualification Vehicle: VFQFPN-8, 3 lots each Assembly Location

Test Description	Test Method	Test Results (Rej / SS)	
		TFME, China	HTC, China
* Temperature Cycling (-55°C to 125°C, 700 cycles)	JESD22-A104	0/25, 0/25, 0/25	0/25, 0/25, 0/25
* HAST - biased (130 °C/85% RH, 96 Hrs)	JESD22-A110	0/25, 0/25, 0/25	0/25, 0/25, 0/25
High Temperature Storage Bake (150°C, 1000 Hrs)	JESD22-A103	0/25, 0/25, 0/25	0/25, 0/25, 0/25
Ball Shear Test	JESD22-B116	0/5, 0/5, 0/5	0/5, 0/5, 0/5
Bond Pull Test	IDT Spec MAC-3010	0/5, 0/5, 0/5	0/5, 0/5, 0/5
X Ray	IDT Spec. MAC-3012	0/45, 0/45, 0/45	0/45, 0/45, 0/45
Moisture Sensitivity Level, MSL	J-STD-20 / MSL 1, 260 °C	0/25, 0/25	0/25, 0/25

* Tests were subjected to Preconditioning per JESD22-A113 prior to stress test



Integrated Device Technology, Inc.
6024 Silver Creek Valley Road, San Jose, CA - 95138

PRODUCT/PROCESS CHANGE NOTICE (PCN)

ATTACHMENT 1 - PCN # : A1804-01

Electrical Test Correlation Results

Vehicle: TSE2004GB2C0
Sample size: 600 electrically good units and 30 GRR units for each Test Location

Description	Existing Test (Carsem, Malaysia)	Alternate Test (TFME, China)	Alternate Test (HTC, China)
Tester Platform	HP83000	Nextest maverick PT2	Vengy v50
Loadboard	SN#1	SN#1	SN#1
Test Program	QC_Cruz_TF	QC_Cruz_TF	QC_Cruz_TF
Test Site	4	4	2
Test Temperature	25°C	25°C	25°C
Test Correlation Results	100%	100%	100%
Number of Good Units Correlated @ ambient	600 pcs	600 pcs	600 pcs
600 units Bin 1 handler run (good units)	Passed	Passed	Passed
Number of GRR Units Correlated @ ambient	N/A	30 pcs	30 pcs
30 units GRR handler run by site	N/A	Passed	Passed
600 units Bin 1 datalog correlation (good units)	Passed	Passed	Passed



Integrated Device Technology, Inc.
6024 Silver Creek Valley Road, San Jose, CA - 95138

PRODUCT/PROCESS CHANGE NOTICE (PCN)

ATTACHMENT 1 - PCN # : A1804-01

Carrier Tape and Plastic Reel comparisons (Carsem and TFME, China)

Table 1: Carrier Tape Comparisons



	Carsem, Malaysia	TFME, China
Part Number	C-PAK BD0200x0300	ECA1941-PS-BLK-520
Ao	2.3+0.1mm	2.3+0.05mm
Bo	3.2+0.1mm	3.2+0.05mm
Ko	1.0+0.1mm	1.0+0.05mm
P	4.0+0.1mm	4.0+0.1mm
W	8.0+0.3mm	8.0+0.2/-0.1mm
Drawing	Refer Page 7	Refer Page 8
Snapshot		

Table 2: Plastic Reel Comparisons

	Carsem, Malaysia	TFME, China
Part Number	NEWTECH P9-065-000 White	E-PAK eRL0126-T08-A47-TRL
Reel Dia	7"	7"
Hub Dia	2"	2"
Drawing	Refer Page 9, 10	Refer Page 11
Snapshot		

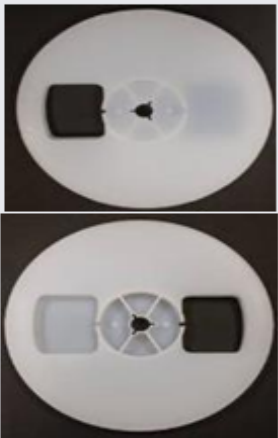
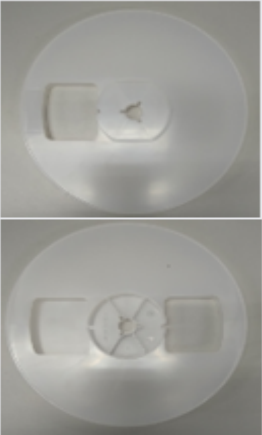

Integrated Device Technology, Inc.
6024 Silver Creek Valley Road, San Jose, CA - 95138

PRODUCT/PROCESS CHANGE NOTICE (PCN)

ATTACHMENT 1 - PCN # : A1804-01

Carrier Tape and Plastic Reel comparisons (Carsem and HTC, China)

Table 3: Carrier Tape Comparisons





	Carsem, Malaysia	HTC, China
Part Number	C-PAK BD0200x0300	ECA1941-PS-BLK-520
Ao	2.3+0.1mm	2.3+0.05mm
Bo	3.2+0.1mm	3.2+0.05mm
Ko	1.0+0.1mm	1.0+0.05mm
P	4.0+0.1mm	4.0+0.1mm
W	8.0+0.3mm	8.0+0.2/-0.1mm
Drawing	Refer Page 7	Refer Page 12
Snapshot		

Table 4: Plastic Reel Comparisons

	Carsem, Malaysia	HTC, China
Part Number	NEWTECH P9-065-000 White	E-PAK eRL0126-T08-A47-TRL
Reel Dia	7"	7"
Hub Dia	2"	2"
Drawing	Refer Page 9, 10	Refer Page 13
Snapshot	 	 

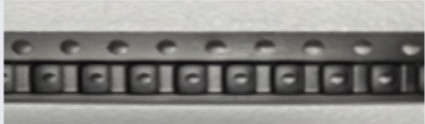

SECTION Y-Y

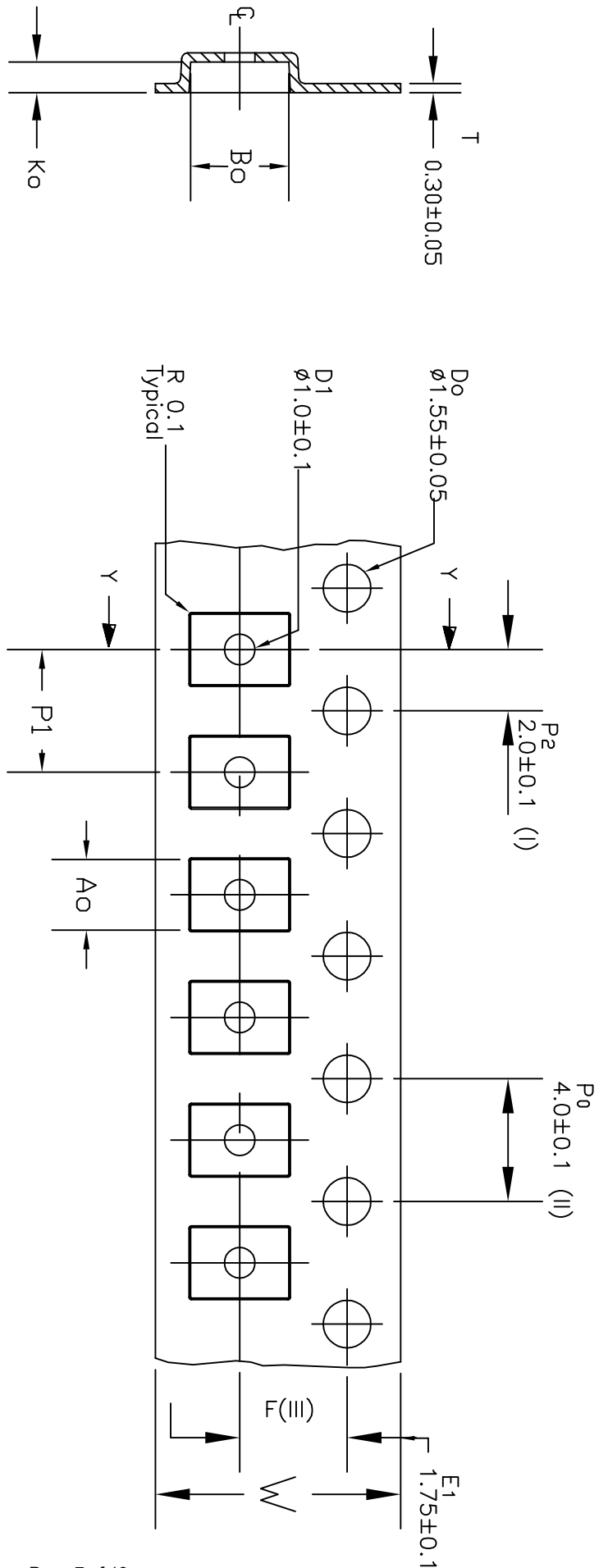
Ao	2.30	+/-0.1
Bo	3.20	+/-0.1
Ko	1.00	+/-0.1
F	3.50	+/-0.05
P1	4.00	+/-0.1
W	8.00	+/-0.3

TOLERANCES UNLESS OTHERWISE SPECIFIED
 DECIMAL 25
 X ± .25
 Y ± .13
 XXX ± .13

ANGLE 4.5°

APPROVALS _____ DATE _____

DRAWN _____

SCALE N/A

SIZE _____

REV _____

DO NOT SCALE DRAWING SHEET 1 OF 1

IDT
 6024 Silver Creek Valley Road,
 San Jose, CA 95138
 PHONE: (408) 284-8200
 FAX: (408) 284-3572

www.IDT.com

TITLE: NC/NCG 8 & NR/NRG 8
 CARRIER TAPE

STOCK NO. N/A
 DRAWING NO. MSC-5940-A
 REV 00

TFME Carrier Tape

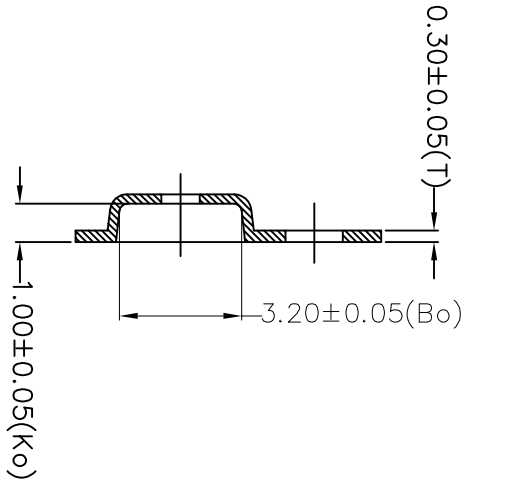

Section B-B

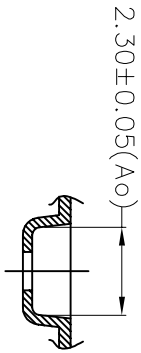
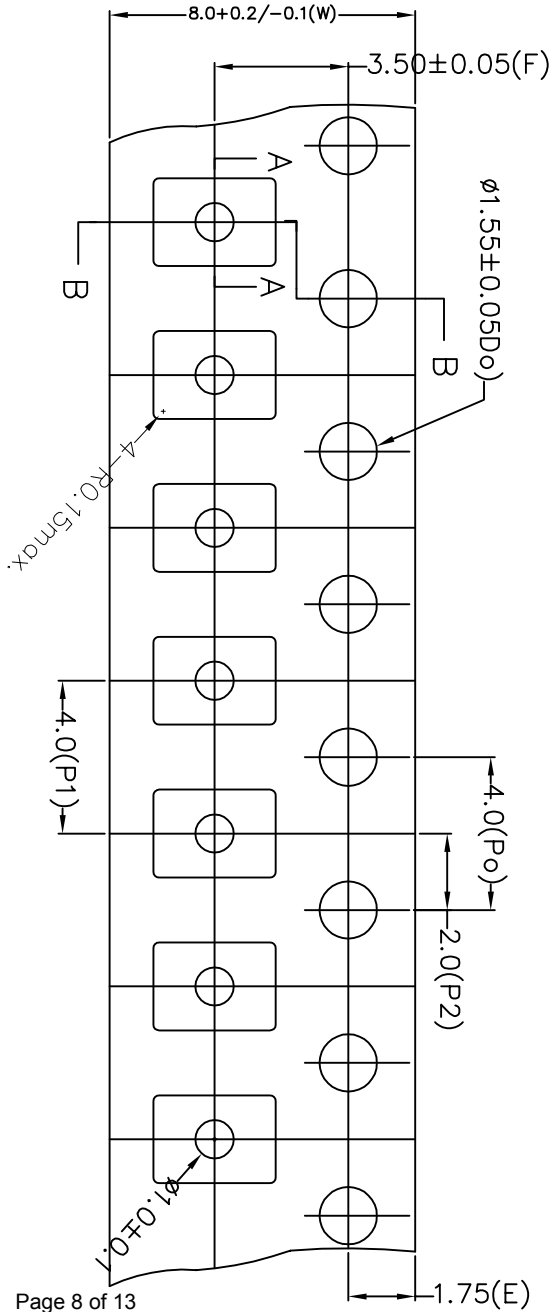

Section A-A

TOLERANCES UNLESS OTHERWISE SPECIFIED
 DECIMAL : X ±.1
 .XX ±.10
 .XXX ±.1
 ANGLE : ±
 ANGULAR : ±



6024 Silver Creek Valley Road,
 San Jose, CA 95138
 PHONE: (408) 284-8200
 FAX: (408) 284-3572

TITLE:

NCG 8 CARRIER TAPE

SCALE
 N/A

STOCK NO.

N/A

DRAWING NO.

MSC-7980-A

REV

00

DO NOT SCALE DRAWING

SHEET 1 OF 1

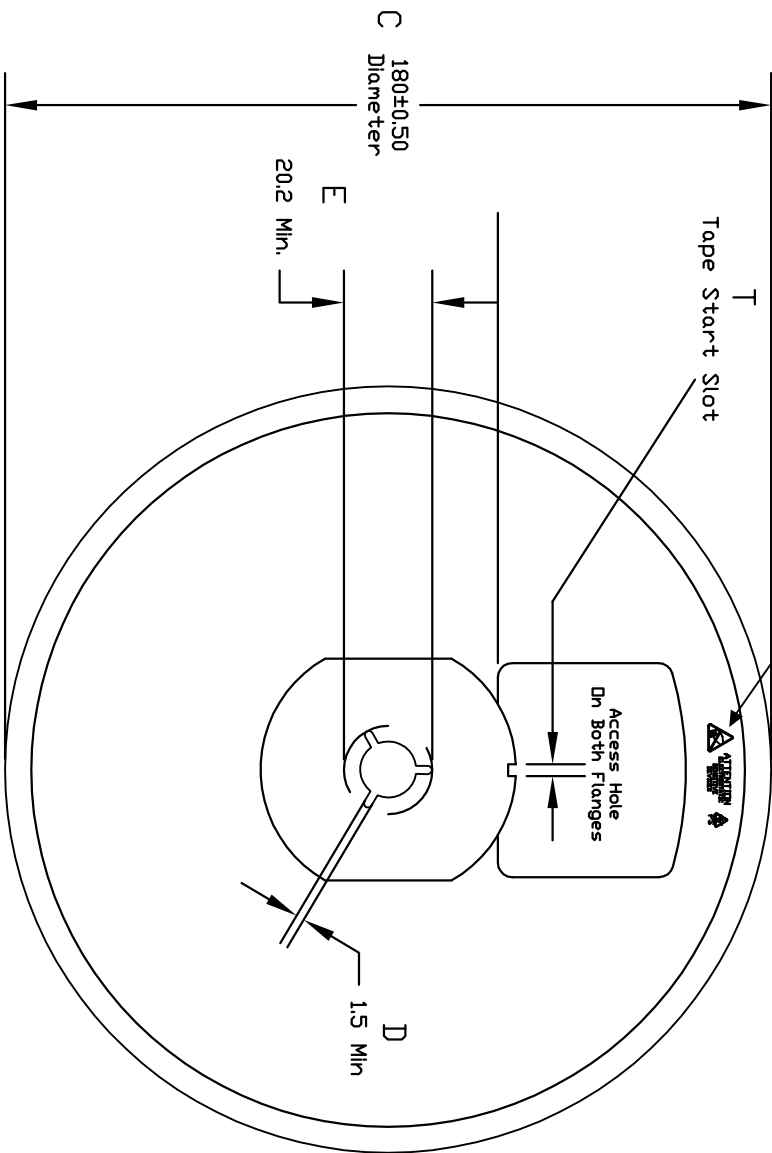

IDT PART NUMBER	SUPPLIER PART NUMBER	T	W1	W2	W3	COLOR
P9-065-000	7" x 8 MM WHITE REEL	3±0.50	8.4+1.5/-0.0	14.4 MAX	7.9 MIN 10.9 MAX	WHITE
P9-065-BLUE	7" x 8 MM BLUE REEL	3±0.50	8.4+1.5/-0.0	14.4 MAX	7.9 MIN 10.9 MAX	BLUE

- NOTES : (UNLESS OTHERWISE SPECIFIED)
1. MATERIAL : AMTISTATIC POLYSTYRENE
 2. ALL DIMENSIONS ARE IN mm.
 3. REEL & ESD SURFACE RESISTIVITY SHALL CONFORM TO IDT SPEC MSA-3018.
 4. SUPPLIER : UNITED NEWTECH
 5. TAPE WIDTH : 8 MM

FRONT VIEW

TOLERANCES UNLESS OTHERWISE SPECIFIED
 DECIMAL .25
 .X ± .25
 .XX ± .13
 .XXX ± .13
 ANGLE ± .5°

IDT
 6024 Silver Creek Valley Road,
 San Jose, CA 95138
 PHONE: (408) 284-8200
 FAX: (408) 284-3572
 www.IDT.com

STOCK NO.	DRAWING NO.	SCALE
8 MM WIDTH PLASTIC REEL (7"/2" HUB)	MSC-5965	N/A
REV	REV	N/A
DO NOT SCALE DRAWING	SHEET 1 OF 3	

Carsem Reel

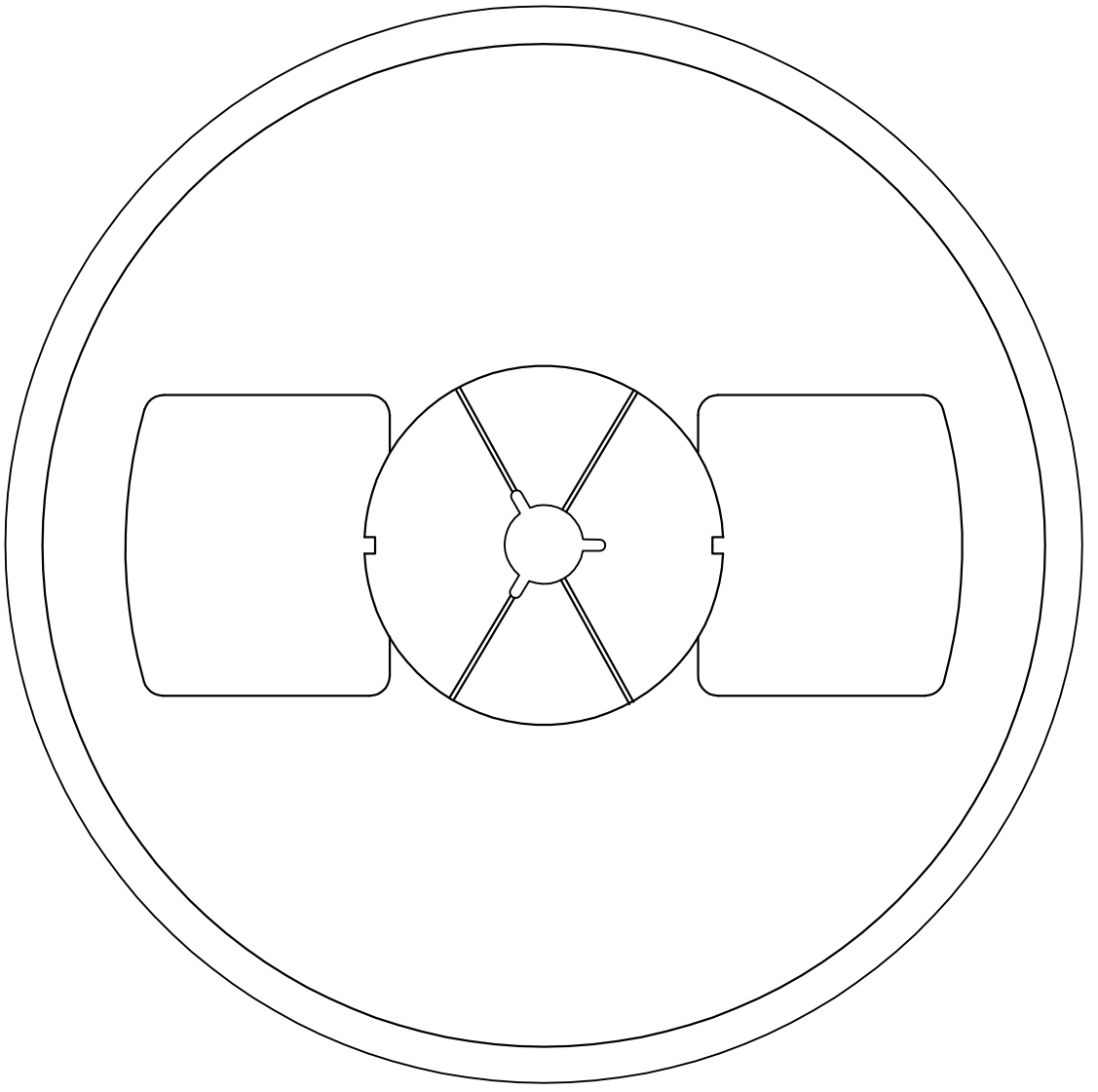
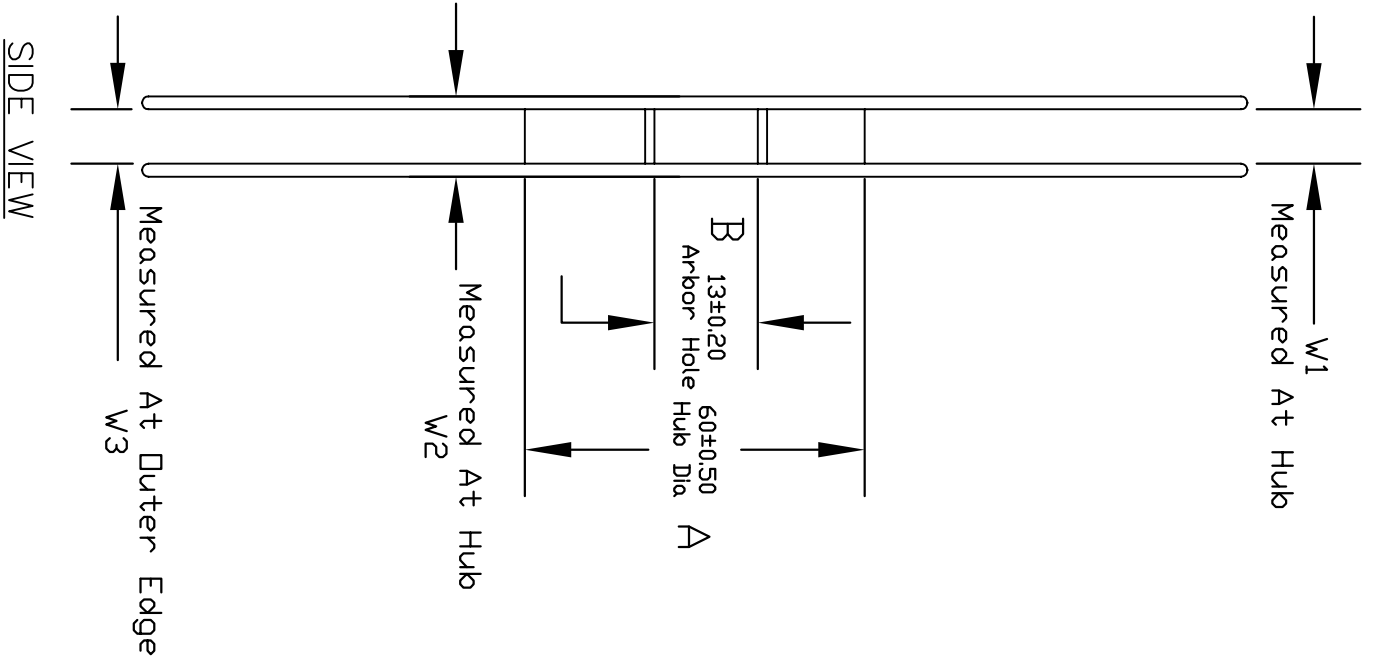

BACK VIEW

SIDE VIEW

TOLERANCES UNLESS OTHERWISE SPECIFIED		ANGLE	
XX ± .25	XX ± .12	± .5°	
APPROVALS		DATE	
DRWN			
TITLE:		SCALE	
8 MM WIDTH PLASTIC		N/A	
REEL (7" / 2" HUB)		SIZE	
		N/A	
STOCK NO.		DRAWING NO.	
REFER TO TABLE		MSC-5965	
DO NOT SCALE DRAWING		REV	
		03	
		SHEET 2 OF 3	



6024 Silver Creek Valley Road,
San Jose, CA 95138
PHONE: (408) 284-8200
FAX: (408) 284-3572

TFME Reel

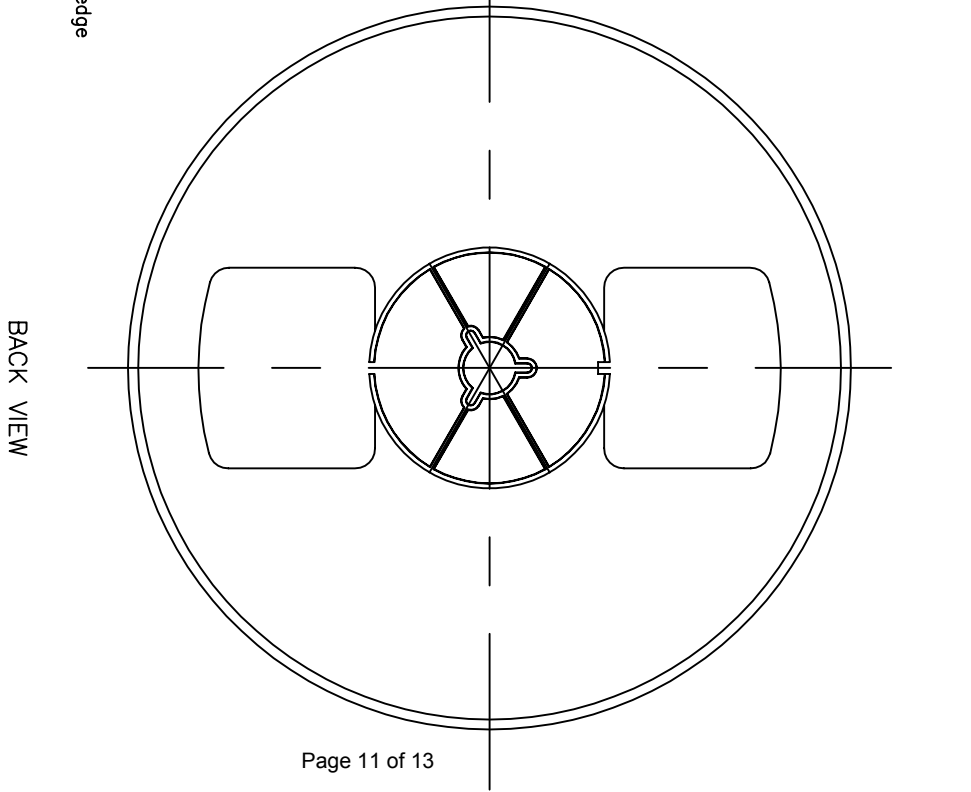
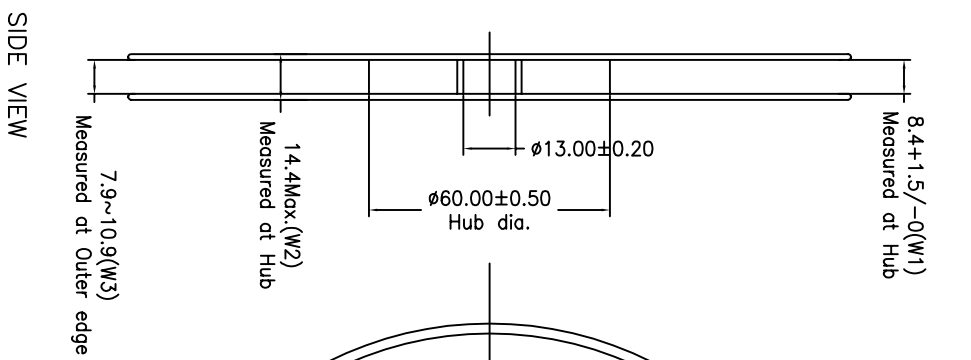
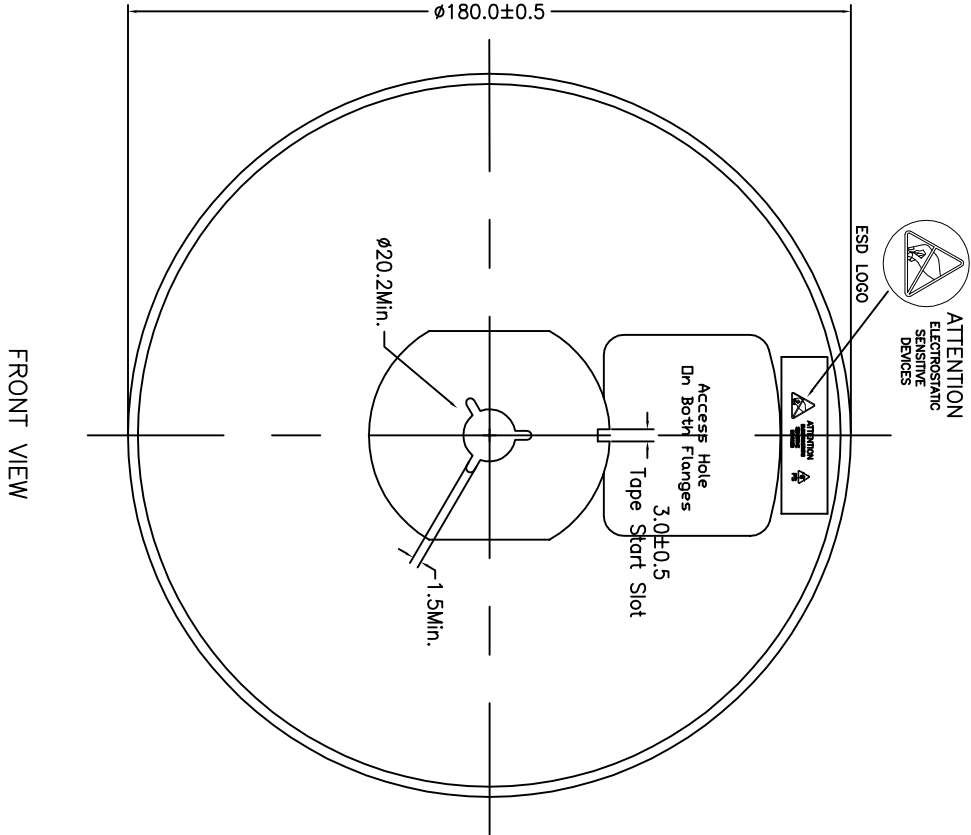

NOTES : (UNLESS OTHERWISE SPECIFIED)
1. COLOR : TRANSLUCENT.

FRONT VIEW

SIDE VIEW

BACK VIEW

TOLERANCES UNLESS OTHERWISE SPECIFIED
DECIMAL : X ± .5
.XX ± .25
.XXX ± .1
ANGLE : ± .5°
ANGULAR : ±



6024 Silver Creek Valley Road,
San Jose, CA 95138
PHONE: (408) 284-8200
FAX: (408) 284-3572

TITLE:		7" PLASTIC REEL FOR 8 MM	
STOCK NO.	DRAWING NO.	REV	SCALE
N/A	MSC-8402-A	00	N/A
DO NOT SCALE DRAWING		SHEET 1 OF 1	

HTC Carrier Tape

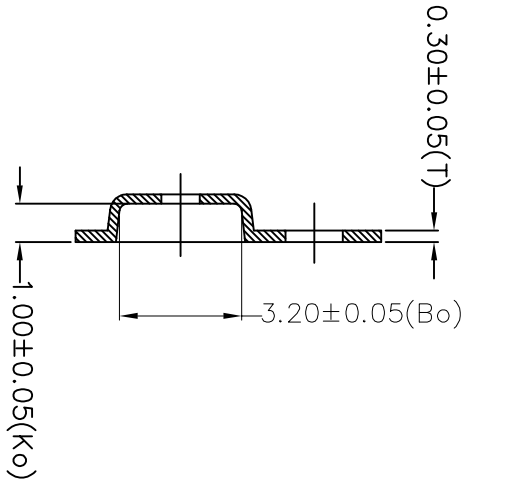

Section B-B

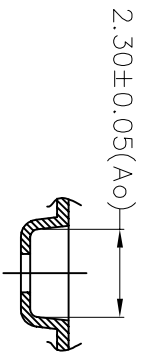
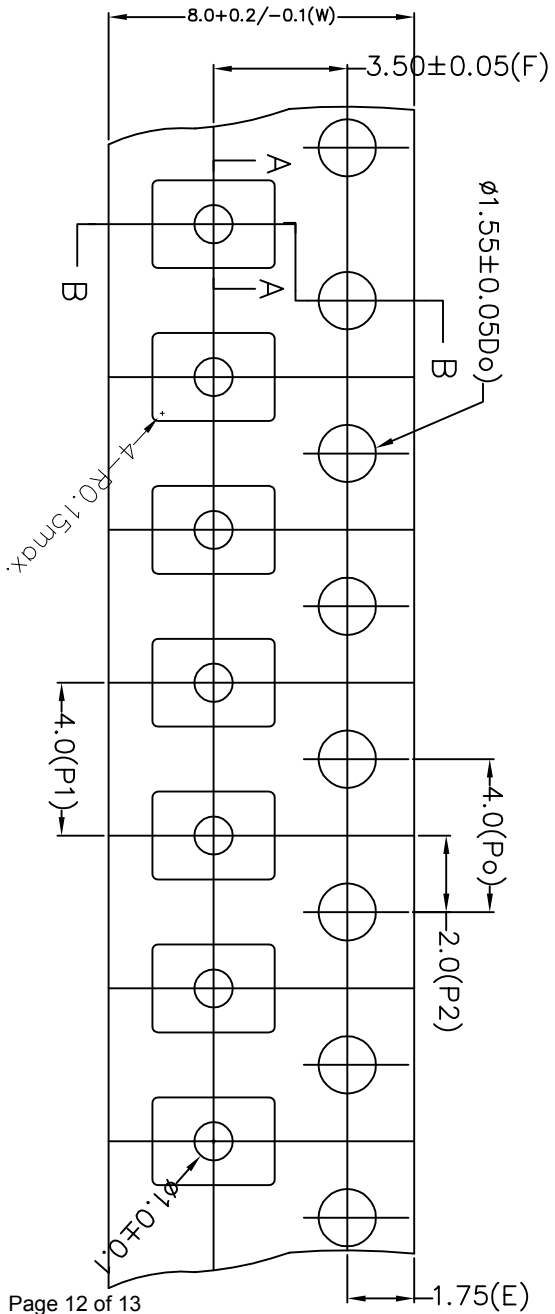

Section A-A

TOLERANCES UNLESS OTHERWISE SPECIFIED
 DECIMAL : X ±.1
 .XX ±.10
 .XXX ±
 ANGLAR : ±



6024 Silver Creek Valley Road,
 San Jose, CA 95138
 PHONE: (408) 284-8200
 FAX: (408) 284-3572

TITLE:

NCG 8 CARRIER TAPE

SCALE
 N/A

STOCK NO.

N/A

DRAWING NO.

MSC-7980-A

REV

00

DO NOT SCALE DRAWING

SHEET 1 OF 1

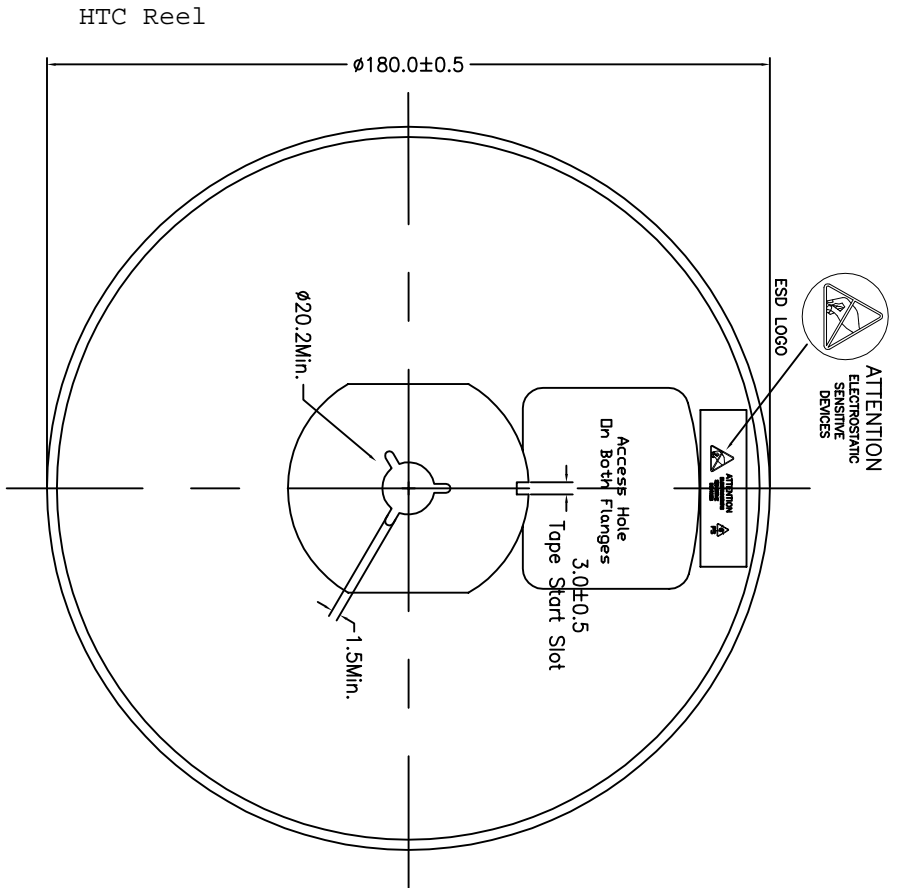

FRONT VIEW

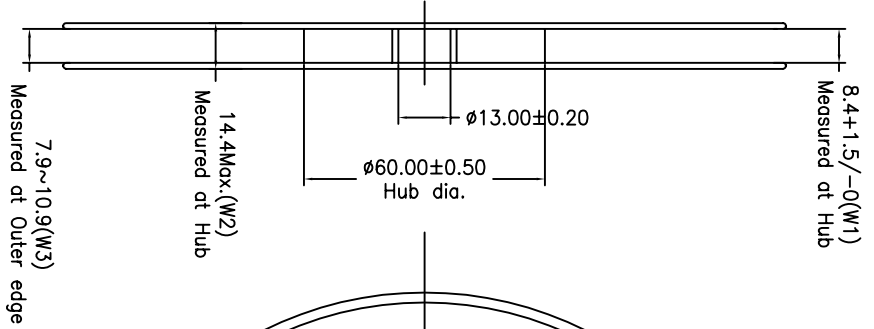

SIDE VIEW

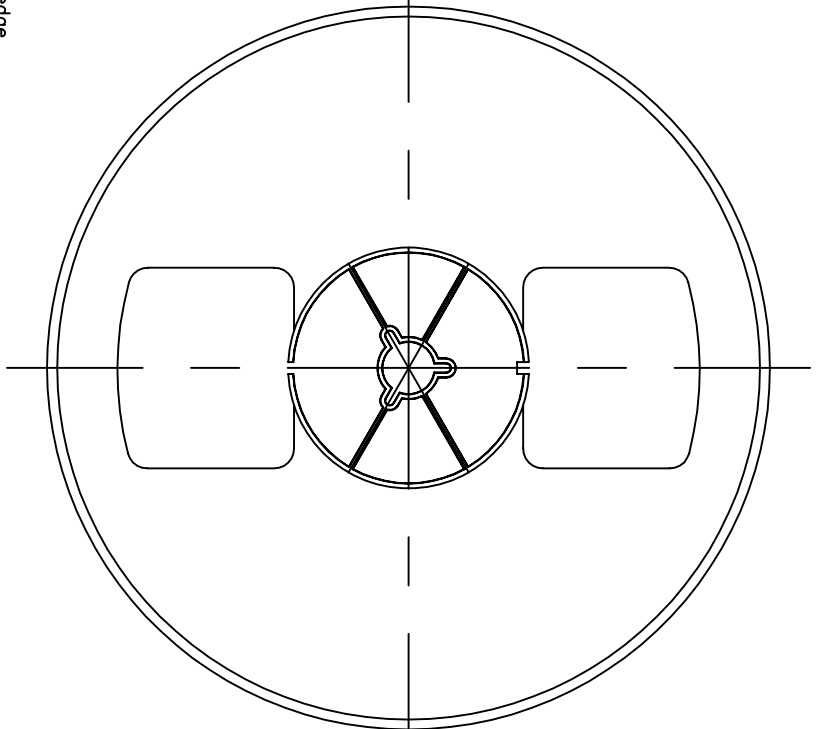

BACK VIEW

NOTES : (UNLESS OTHERWISE SPECIFIED)
1. COLOR : TRANSLUCENT.

TOLERANCES UNLESS OTHERWISE SPECIFIED
DECIMAL : X ±.5
.XX ±.25
.XXX ±
ANGLE : ±.5°
ANGULAR : ±



www.IDT.com

6024 Silver Creek Valley Road,
San Jose, CA 95138
PHONE: (408) 284-8200
FAX: (408) 284-3572

TITLE:		7" PLASTIC REEL FOR 8 MM	
STOCK NO.	DRAWING NO.	SCALE	
N/A	MSC-8402-A	N/A	
DO NOT SCALE DRAWING	SHEET 1 OF 1	REV	00
		SIZE	N/A