

User Manual

DA14585 IoT Multi Sensor Development Kit Hardware Design

UM-B-095

Abstract

This document describes the hardware design of DA14585 IoT Multi Sensor development kit, which is based on Dialog Semiconductor's DA14585 Bluetooth® Low Energy SoC. This development kit includes an accelerometer/gyro sensor, digital microphone, Gas (CO2) sensor, and an infrared proximity combined with an ambient light sensor in a single package.

Contents

Abstract	1
Contents	2
Figures	3
Tables	4
1 Terms and Definitions	5
2 References	5
3 Introduction	6
4 System Overview	6
4.1 Features	6
4.2 Block Diagram.....	7
4.3 PCBA Overview	8
5 DA14585 IoT MSK	9
5.1 DA14585 SoC	9
5.1.1 DA14585 Pin Assignment.....	10
5.1.2 DA14585 Power Pins.....	12
5.2 Flash Memory	12
5.3 Crystal Oscillators	13
5.4 Power Amplifier	14
5.4.1 Control Signals	15
5.4.1.1 RF Control Signals.....	15
5.4.1.2 Power Control Signals	16
5.5 Microphone	17
5.6 GPO Expander	17
5.7 Expansion Slots	18
5.8 Accelerometer/Gyroscope Sensor	19
5.8.1 Additional (Non-Populated) Motion Sensor	20
5.9 Ambient Light and IR Proximity Sensor	21
5.10 Buzzer	22
5.11 Electronic Compass (Magnetometer)	23
5.12 Environmental and Gas Sensor	24
5.13 Barometric Pressure Sensor	26
5.14 System Power Supply Options	27
5.14.1 Battery Power Options.....	27
5.14.2 Alternative Power Options	29
5.15 Printed Antennas.....	29
6 Schematics	31
7 PCB Layout	32
8 Power Measurements	33
9 Enclosure	37

DA14585 IoT Multi Sensor Development Kit Hardware Design Company Confidential

9.1 Adjust IR Proximity Sensor Performance inside the Enclosure	38
10 Configuration of the Debugging Interface	41
Revision History	43

Figures

Figure 1: Block Diagram of DA14585 IoT MSK from Top Level.....	7
Figure 2: PCBA of a DA14585 IoT MSK: Top view.....	8
Figure 3: PCBA of DA14585 IoT MSK: Bottom View	9
Figure 4: The System Schematic of DA14585 SoC	10
Figure 5: Serial NOR Flash Memory	13
Figure 6: Block Diagram of the SKY66111-11 Power Amplifier	15
Figure 7: Schematic of SKY66111-11 Front End Module	15
Figure 8: Schematic of SPK0838HT4H Microphone	17
Figure 9: Schematic of GPO Expander	18
Figure 10: Schematic of Expansion Slots.....	19
Figure 11: Schematic of ICM42605 Motion Sensor	20
Figure 12: Schematic of the Ambient Light and IR Proximity Sensor	21
Figure 13: Buzzer Schematic	22
Figure 14: Frequency Response versus dB Magnitude	23
Figure 15: Schematic of the Magnetic Sensor	24
Figure 16: Schematic of the Environmental and Gas Sensor	25
Figure 17: Schematic of Barometric Sensor.....	27
Figure 18: Power ON/OFF Switch and Power Options	28
Figure 19: BT2, Coin Cell Battery Holder Position	29
Figure 20: The Printed IFA of a Reduced Size on PCB	30
Figure 21: Radiation Pattern of the Printed IFA of a Reduced Size	30
Figure 22: Schematic 1 of DA14585 IoT MSK	31
Figure 23: Schematic 2 of DA14585 IoT MSK	31
Figure 24: PCB of the DA14585 IoT MSK: Top View.....	32
Figure 25: PCB of DA14585 IoT MSK: Bottom View	33
Figure 26: DA14585 Disconnected, All Sensors in Sleep Mode	34
Figure 27: DA14585 Connected, All Sensors Active.....	34
Figure 28: DA14585 Connected, Gas Sensor Off Only	35
Figure 29: DA14585 Connected, Environmental and Gas Sensor OFF	35
Figure 30: DA14585 Connected, Environmental, Gas, ALS and IR Sensors OFF	36
Figure 31: DA14585 Connected, Motion Sensor ON Only.....	36
Figure 32: DA14585 IoT MSK Enclosure: Top View	37
Figure 33: DA14585 IoT MSK Enclosure: Bottom View	38
Figure 34: DA14585 IoT MSK Enclosure: Side View	38
Figure 35: Reading Panel of Dialog IoT Sensors App	38
Figure 36: Menu Panel of Dialog IoT Sensors APP	39
Figure 37: Settings Menu of Dialog IoT Sensors App	40
Figure 38: Choices of Basic Settings in Dialog IoT Sensors App	40
Figure 39: Suggested Values of Proximity Hysteresis to Adjust IR Proximity Performance	Error!
Bookmark not defined.	
Figure 40: Communication Interface Board (CIB)	41
Figure 41: Connection between DA14585 IoT MSK and the CIB	42

Tables

Table 1: GPIO Pin Assignment for DA14585 IoT MSK	10
Table 2: Y1 (16 MHz Crystal) Characteristics	13
Table 3: Y2 (32 kHz Crystal) Characteristics	14
Table 4: Truth Table for SKY66111-11	16
Table 5: Signal Configurations for Power Control	16
Table 6: GPO Expander Pin Assignment	17
Table 7: Indicative Electrical Characteristics of ICM42605 Motion Sensor	20
Table 8: Motion Sensor Mounting Scenarios	21
Table 9: Indicative Electrical Characteristics of VCNL4010 ALS and IR Sensor	22
Table 10: Indicative Electrical Characteristics of AK09915C Magnetic Sensor	24
Table 11: Indicative Electrical Characteristics of BME680	26
Table 12: Indicative Electrical Characteristics of ICP10110	27
Table 13: Collective Table for Current Measurement	37

1 Terms and Definitions

ALS	Ambient Light Sensor
APDU	Application Protocol Data Unit
AVG	Average
BLE	Bluetooth Low Energy
BOM	Bill of Materials
CIB	Communication Interface Board
DCXO	Digitally Controlled Crystal Oscillator
e-CO ₂	Equivalent CO ₂
ESR	Equivalent Series Resistance
FW	Firmware
HW	Hardware
IAQ	Indoor Air Quality
IFA	Inverted-F Antenna
IR	Infrared
IoT	Internet of Things
JTAG	Joint Test Action Group (test interface)
LED	Light Emitting Diode
L2CAP	Logical Link Control and Adaptation Layer Protocol
MSK	Multi Sensor development kit
NP	Non-Populated
PA	Power Amplifier
PCM	Pulse Code Modulation
PDM	Pulse Density Modulation
RF	Radio Frequency
SoC	System on Chip
SIG	Special Interest Group
SPI	Serial Peripheral Interface
UART	Universal Asynchronous Receiver/Transmitter
USB	Universal Serial Bus
VOC	Volatile Oxide Compound

2 References

- [1] DA14585, Datasheet, Dialog Semiconductor.
- [2] AN-B-027, Designing printed antennas for Bluetooth® Smart, Application Note , Dialog Semiconductor
- [3] AN-B-054, DA14585 Application Hardware Design Guidelines, Application Note , Dialog Semiconductor
- [4] UM-B-089, DA14585 Range Extender Reference Application, User Manual, Dialog Semiconductor.
- [5] UM-B-096, DA14585 IoT Multi Sensor Development Kit Software Reference Application, User Manual, Dialog Semiconductor.

3 Introduction

Today's Internet of Things (IoT) market is extremely vibrant and promising. Various applications keep appearing on the market. They are expected to contain as many sensors as possible while consuming minimum power. Dialog's DA14585 IoT Multi Sensor development kit (MSK) uses components that consume low power and allows the development of IoT applications to offer a wide range of products and to react to the market fast. Using this development kit, users can develop numerous applications using the same hardware and support different use cases through the same firmware.

This document describes the hardware design for DA14585 IoT MSK. To learn about the architecture and configuration of the software reference applications, please refer to [\[5\]](#).

4 System Overview

4.1 Features

- Highly integrated DA14585 Bluetooth® Smart SoC from Dialog Semiconductor
- Stand-alone module
- Low cost due to printed antenna
- Low cost PCB
- Combined accelerometer/gyroscope sensor unit
- Combined sensors:
 - Accelerometer and gyroscope sensor unit
 - Gas and environmental (Temperature, Humidity and Pressure)
 - ALS and IR proximity
- Access to processor via JTAG and UART from the enclosure
- Programmable RF power up to +9.3 dBm
- Three LED indicators
- General purpose push button
- Expansion slots
- Powered by two low cost AAA alkaline batteries

4.2 Block Diagram

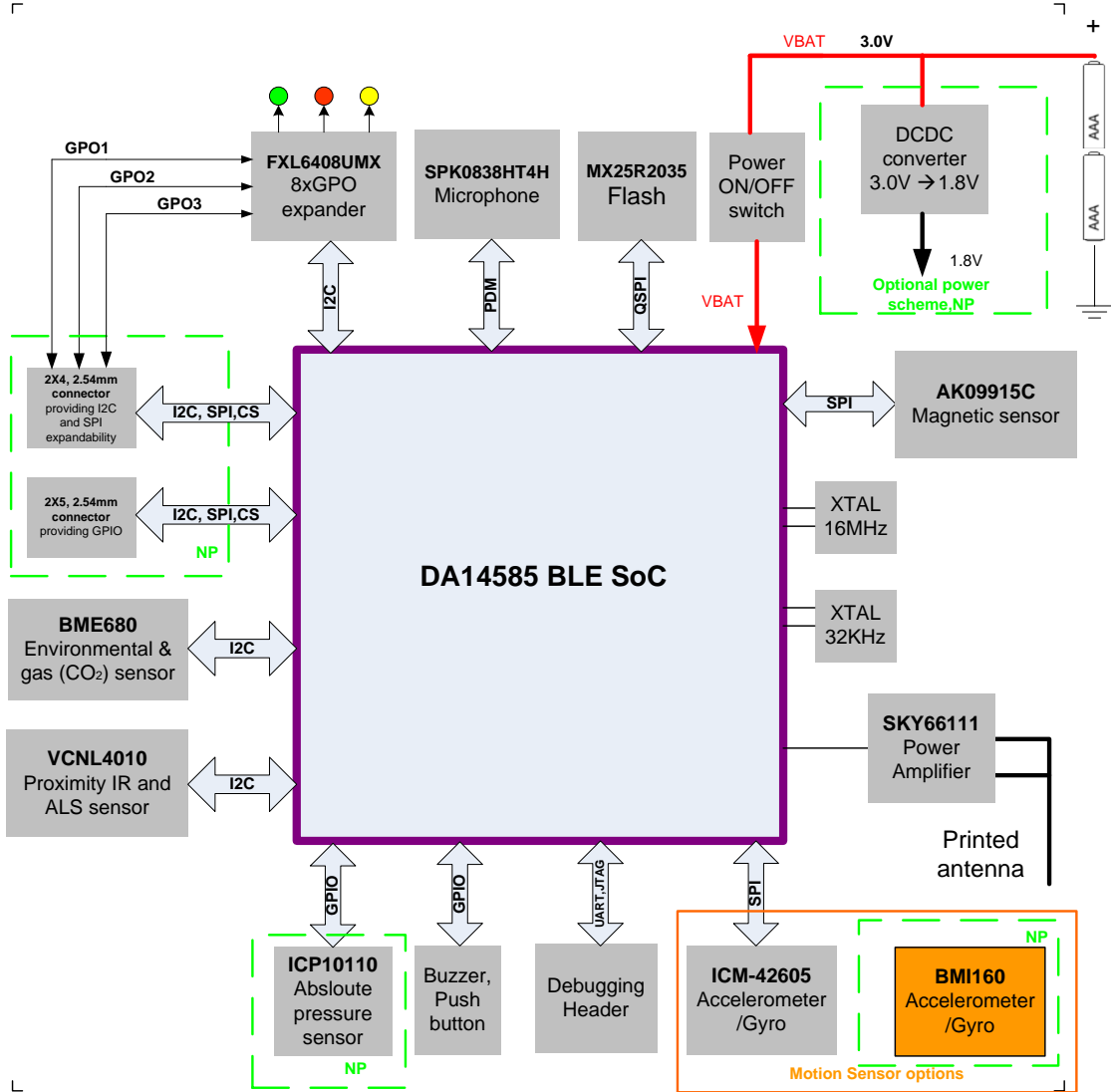

Figure 1: Block Diagram of DA14585 IoT MSK from Top Level

4.3 PCBA Overview

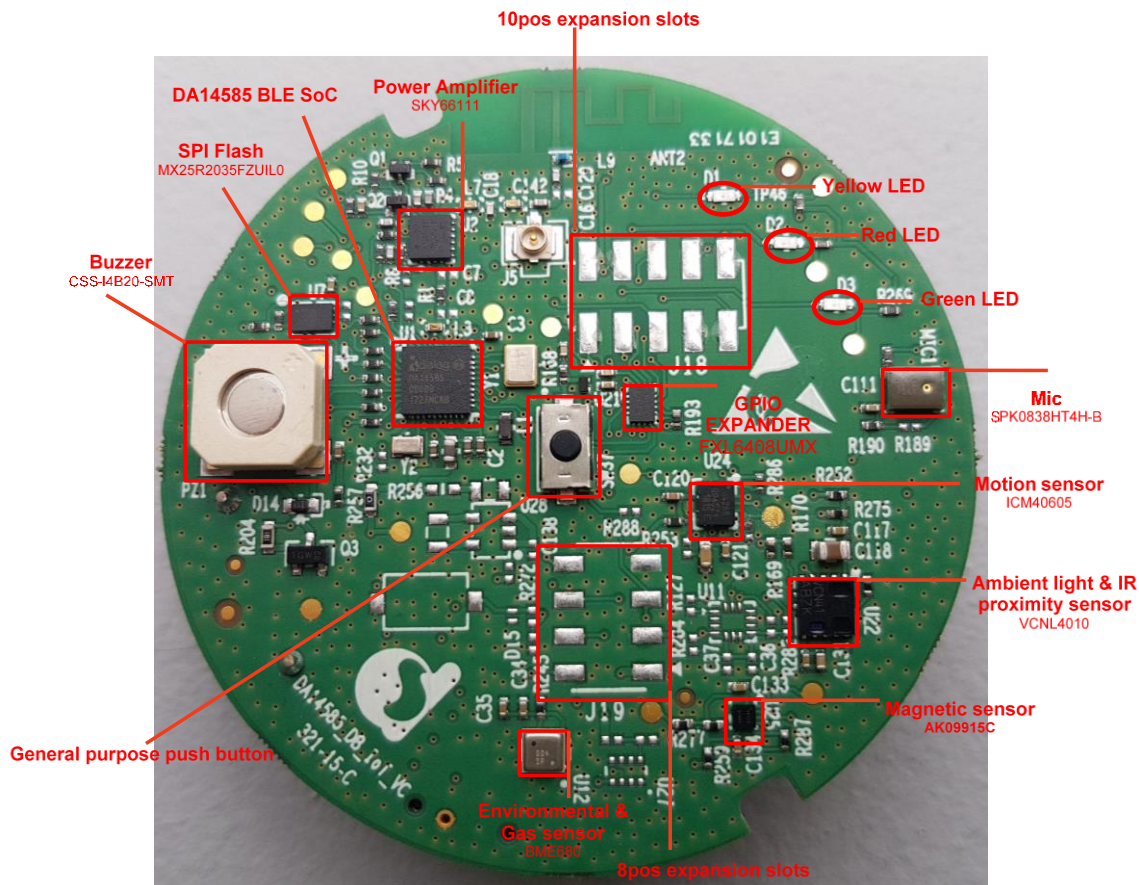

Figure 2: PCBA of a DA14585 IoT MSK: Top view

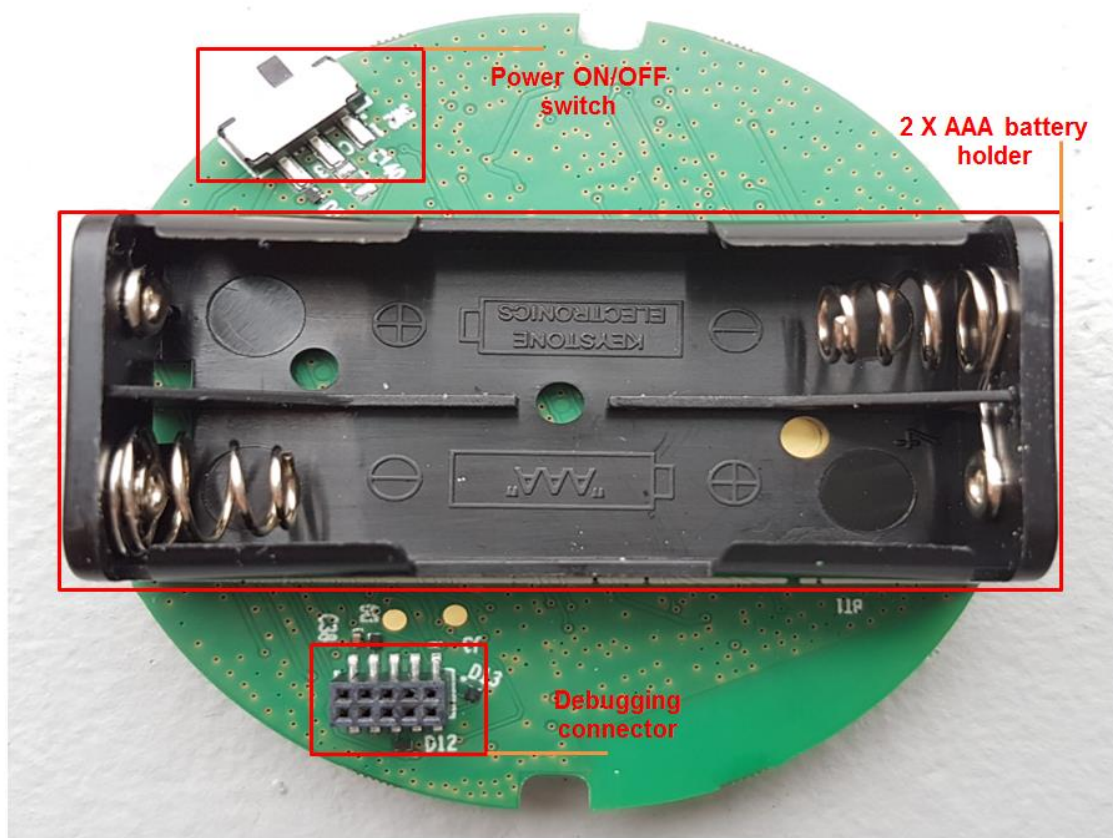

Figure 3: PCBA of DA14585 IoT MSK: Bottom View

5 DA14585 IoT MSK

5.1 DA14585 SoC

DA14585 SoC is an optimized version of DA14580, offering a reduced boot time and supporting up to eight connections. It has a fully integrated radio transceiver and baseband processor for Bluetooth® Low Energy. It can be used as a stand-alone application processor or as a data pump in hosted systems.

The Bluetooth® Low Energy firmware includes L2CAP service layer protocols, Security Manager (SM), Attribute Protocol (ATT), Generic Attribute Profile (GATT), and Generic Access Profile (GAP). The firmware also supports all profiles published by the Bluetooth SIG as well as custom profiles.

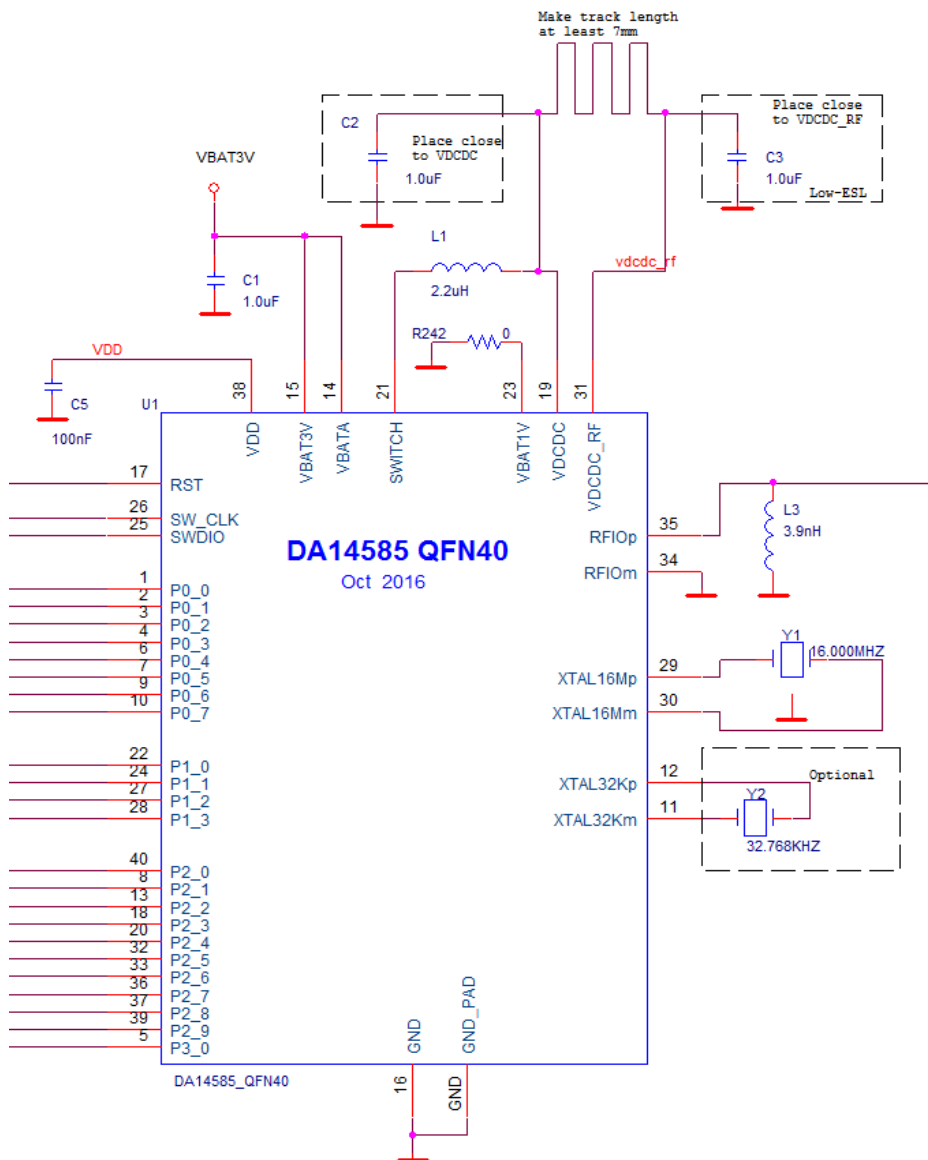

Figure 4: The System Schematic of DA14585 SoC

5.1.1 DA14585 Pin Assignment

Table 1 shows GPIO pin assignment of DA14585 IoT MSK and related pin names for GPIO in the QFN40 package of DA14585.

Table 1: GPIO Pin Assignment for DA14585 IoT MSK

Pin Name	Pin Assignment for GPIO	Comments
P0_0	SPI_CLK	SPI clock (Flash memory)
P0_1	CTRL_TX	PA's control signal

Pin Name	Pin Assignment for GPIO	Comments
P0_2	CTRL_RX	PA's control signal
P0_3	SPI_CS	SPI chip select (Flash memory)
P0_4	UTX	UART transmit signal - Also connected on the expansion slots J8 and J9
P0_5	SPI_MISO/URX	SPI multiplexed with UART receive signal- Also connected on the expansion slots J8 and J9
P0_6	SPI_MOSI	SPI
P0_7	GPIOx3	External GPIO pin - To CTRL_PWM_BP via a non-pop resistor (R288)
P1_0	PDM_DATA	Audio interface (Mic)
P1_1	DRDY_AK09915	Data ready pin for the AK09915 magneto module
P1_2	INT_ICM42605	Interrupt pin for the ICM42605 accelerometer Multi Sensor gyro module
P1_3	PB1	Push button
P2_0	PDM_CLK	Audio interface (Mic)
P2_1	SPI_CS1	Chip select for the SPI the ICM40605 accelerometer Multi Sensor gyro module
P2_2	GPIOx	External GPIO pin
P2_3	INT_VCNL4010	Interrupt pin for the VCNL4010 optical sensor module
P2_4	SPI_CS2	Chip select for the SPI, connected to the testing connector for external use (additional sensor)
P2_5	SDA	I2C data (AK09915 magneto, Optical sensor module, GPIO expander)
P2_6	SCK	I2C clock (AK09915 magneto, Optical sensor module, GPIO expander)
P2_7	SPI_CS3	Chip select magneto (AK09915)

Pin Name	Pin Assignment for GPIO	Comments
P2_8	Buzzer(Multi Sensor)	Buzzer
P2_9	CTRL_PWM	PWM signal for PA power control
P3_0	GPIOx2	External GPIO pin - To the non-populated push button

5.1.2 DA14585 Power Pins

The power management subsystem of DA14585 SoC consists of:

- VBAT1V: INPUT.
 - Battery connection for an alkaline or a NiMH battery (1.5 V).
 - Power input in boost configuration only.
 - For buck configuration, this pin is shorted to GND.
- VBAT3V: INPUT/OUTPUT.
 - Battery connection for a single coin battery (3 V) or dual AAA batteries (2 × 1.5 V).
 - Power input in buck configuration only.
- SWITCH: INPUT/OUTPUT.
 - Connection for the external inductor of the DC-DC converter.
- VDCDC: Output of the DC-DC converter.
- VDCDC_RF: Supply input of the Bluetooth radio.
- VDD: INPUT.
 - This pin is used for testing purposes only.

The power supply of the DA14585 IoT Multi Sensor development kit includes:

- Battery type:
Two standard non-rechargeable AAA batteries.
- DC-DC converter:
The internal DC-DC converter has been configured to operate in Buck mode.
- Power ON/OFF switch:
This reference design is equipped with a power ON/OFF switch.
- The track length between the VDCDC pin and the VDCDC_RF pin on the PCB should be at least 7 mm long.

5.2 Flash Memory

DA14585 uses an external Serial NOR Flash memory ([Figure 5](#)) to mirror its contents to RAM and execute the content. The Flash memory type used is MX25R2035FZUILO:

- 2 Mbit QSPI Flash memory, operated in single I/O mode
- Operating voltage: 1.65 V to 3.6 V for read, erase, and program operations
- 8USON package

Please notice that a pull-up resistor has been added on the chip select (CS) pin. The reason is that during power-up and power-down, the pin CS needs to follow the voltage applied to the pin VCC to keep the device not selected.

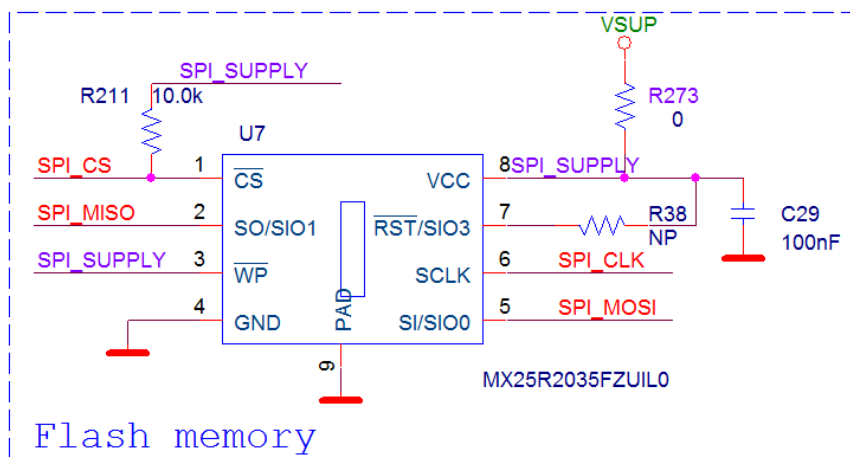

Figure 5: Serial NOR Flash Memory

5.3 Crystal Oscillators

DA14585 SoC has two Digitally Controlled Crystal Oscillators (DCXO), one at 16 MHz (XTAL16M) and the other at 32.768 kHz (XTAL32K). XTAL32K has no trimming capabilities and is used as the clock for the Extended/Deep Sleep modes. XTAL16M can be trimmed.

The crystals used on the DA14585 IoT Multi Sensor development kit are specified in Table 2 and Table 3.

Table 2: Y1 (16 MHz Crystal) Characteristics

Reference Designator	Value
Part Number	7M-16.000MEEQ-T
Frequency	16 MHz
Accuracy	±10 ppm
Load Capacitance (CL)	10 pF
Shunt Capacitance (C0)	3 pF
Equivalent Series Resistance (ESR)	100 Ω
Drive Level (PD)	50 μW

Table 3: Y2 (32 kHz Crystal) Characteristics

Reference Designator	Value
Part Number	ABS06-32.768KHz-9-T
Frequency	32.768 kHz
Accuracy	±20 ppm
Load Capacitance (CL)	9 pF
Shunt Capacitance (C0)	1.2 pF
Equivalent Series Resistance (ESR)	90 kΩ
Drive Level (PD)	0.1 to 0.5 μW

5.4 Power Amplifier

The amplifier circuit is the [SKY66111-11](#) from Skyworks. The SKY66111-11 is a fully integrated RF Front End Module (FEM) designed for Smart Energy applications. The device provides a PA and digital controls compatible with 1.7 V to 5 V CMOS levels. The basic characteristics for the SKY66111-11 are:

- TX Power:10 dBm
- TX current: 10 mA
- RX sensitivity: SoC Multi Sensor1 (see [Note 1](#))
- RX current: 1 μA
- Sleep current < 1 μA
- Supply operation:1.8 to 5 V
- CTX and CRX control signals
- RX bypass
- One antenna port

Note 1 The FEM presents around 1dB insertion loss compared to the case where no PA is used.

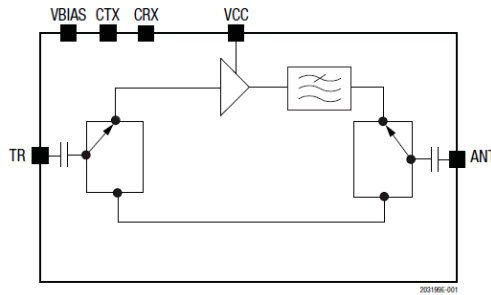

Figure 6: Block Diagram of the SKY66111-11 Power Amplifier

The SKY66111-11 CTX pin is used as the TX control signal and amplifier bias voltage while CRX pin is used as the RX control signal (Figure 6).

The SKY66111-11 BIAS pin supplies the bias to the internal PA (Figure 6). By varying the voltage at this pin, PA operating parameters, including gain, supply current, and efficiency, can be adjusted. The desired bias voltage can also be generated by connecting BIAS to the GPIO controlling CTX with a resistor. In the current design, the BIAS pin is connected to the CTX via resistor R7 (Figure 7), providing a constant voltage, VBIAS, of 1.8 V when the PA is enabled. The resistor value is adjusted so that the maximum 9.3 dBm output power is achieved.

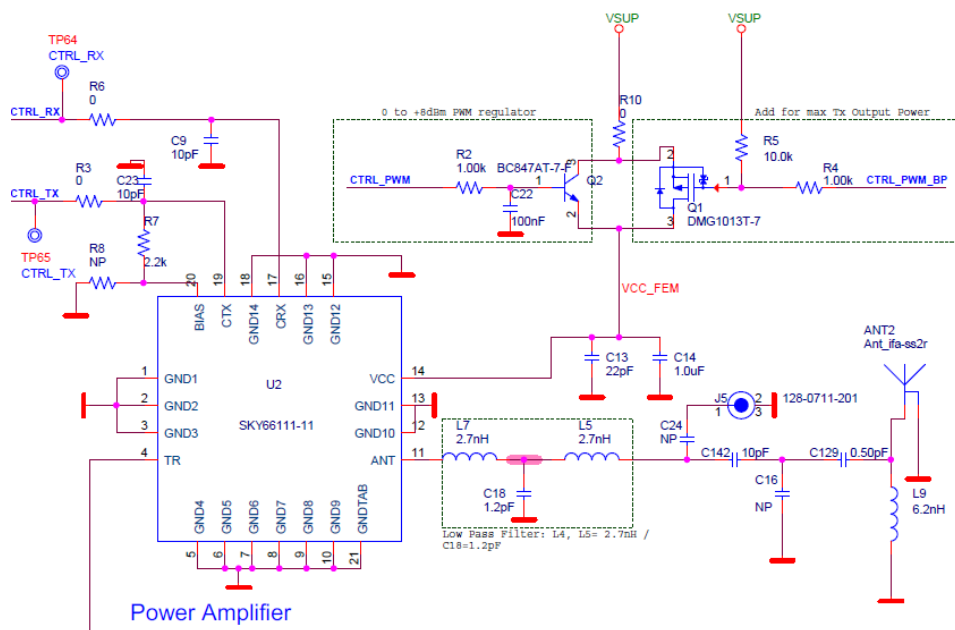

Figure 7: Schematic of SKY66111-11 Front End Module

5.4.1 Control Signals

5.4.1.1 RF Control Signals

The SKY66111-11 is controlled by CTX and CRX control signals. Their functionality is explained in Table 4.

Table 4: Truth Table for SKY66111-11

Mode	CTX	CRX	BIAS
Sleep mode	0	0	0
Receive (RX) mode	0	1	0
Transmit (TX) mode	1	0	1 (See Note 2)
Non-permissible state (See Note 3)	1	1	X

Note 2 Analog voltage control for PA output power.

Note 3 This state will enable both the TX and RX paths. It is not permitted to operate in this state.

5.4.1.2 Power Control Signals

An external circuit is used to adjust the voltage level of the VCC power supply pin in SKY66111-11. By adjusting VCC, the output power of the PA can be regulated.

In general, the system can be configured to operate in three different modes:

- Programmable Output Power Mode:
 - A PWM signal with programmable duty cycle drives the external circuit.
 - The system operates in the range of 0 to +8 dBm by steps of 0, 2, 4, 6, and 8 dBm defined by the used duty cycle.
- Maximum Output Power Mode:
 - The system operates at the maximum power (+9.3dBm) as defined by the RBIAS.
- Bypass Mode: the PA is bypassed.

To configure the programmable output power mode and the maximum output power mode, the following two control signals are used:

- CTRL_PWM:
 - A PWM generated from DA14585 SoC with programmable duty cycle.
 - Uses timer0.
- CTRL_PWM_BP:
 - normal GPIO configured low or high (Accessed via the GPO expander)

To configure the bypass mode, the CTX and CRX inverted signals are used (see [Note 4](#)).

The signal configuration for each mode are described in [Table 5](#).

Table 5: Signal Configurations for Power Control

Mode	CTRL_PWM	CTRL_PWM_BP	CTX	CRX
Programmable Output Power Mode	PWM	1	1	0
Maximum Power Mode	0	0	1	0
Bypass Mode	Input pull-down	0	0 (see Note 4)	1 (see Note 4)

Note 4 CTX and CRX are configured as normal GPIO and not extracted from the diagnostic port. CTX is configured LOW and CRX HIGH during transmission.

5.5 Microphone

The [SPK0838HT4H-B](#) from Knowles is a miniature, high performance, low power, and top port silicon digital microphone with a single-bit PDM output.

Due to its high power consumption at sleep mode, it is supplied via a dedicated GPO from the GPIO expander.

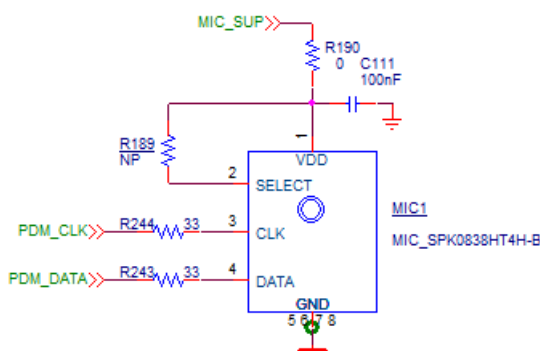

Figure 8: Schematic of SPK0838HT4H Microphone

5.6 GPO Expander

Due to the high GPO demand in this reference design, a GPO expander is necessary. The used component is the low-power, I2C-controlled [FXL6408UMX](#) from Fairchild. It uses both power rails of 1.8 V and 3.3 V while its power consumption remains very low at only 1.5 μ A (Sleep current).

Table 6: GPO Expander Pin Assignment

GPO Expander Pin (FXL6408UMX)	Pin description	Comments
GPO 0	LED YELLOW	LED
GPO 1	MIC_SUP	Supply voltage for the PDM microphone
GPO 2	LED RED	LED
GPO 3	CTRL_PWM_BP	Controlling PA max power
GPO 4	LED GREEN	LED

GPO 5	GPO_EXT1	GPO for usage connected to the expansion slot
GPO 6	GPO_EXT2	GPO for usage connected to the expansion slot
GPO 7	GPO_EXT3	GPO for usage connected to the expansion slot

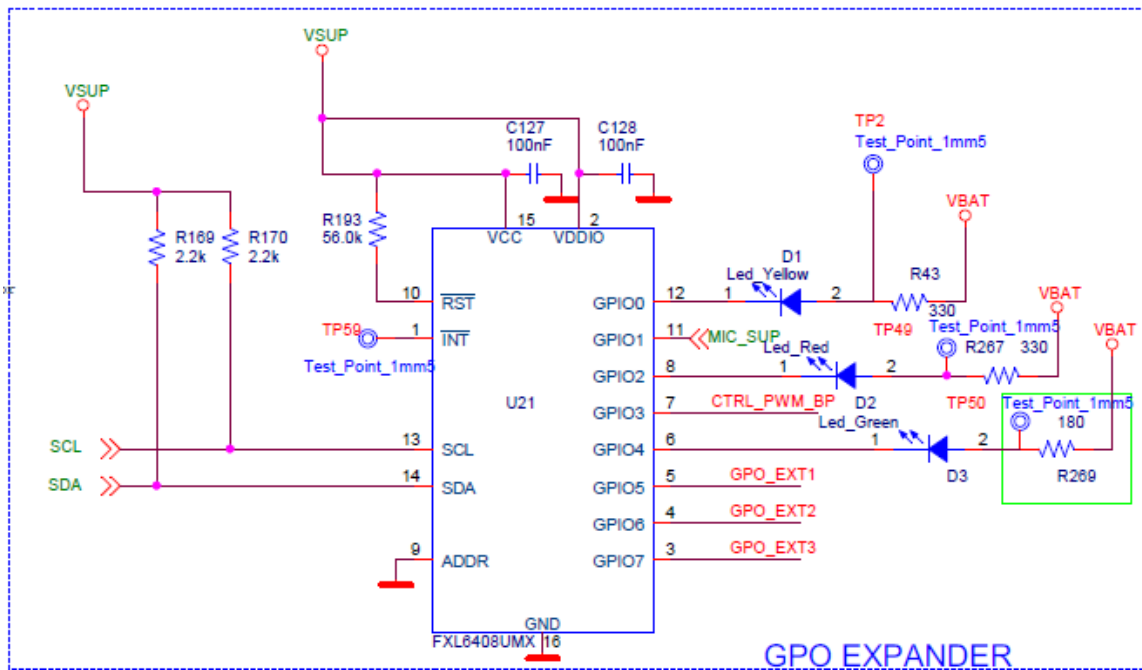

Figure 9: Schematic of GPO Expander

5.7 Expansion Slots

DA14585 IoT MSK features two connection slots (J18 and J19) of a standard 2.54 mm pitch that enables developers to connect additional peripheral and sensors modules as it outputs the SPI with dedicated chip select SPI_CS2 and I2C interface. To provide users with programming and debugging capabilities, the JTAG/UART P0_4 and P0_5 GPIOs are also mapped on the J18 slot. Three spare DA14585 GPIOs and three from the GPO expander are also connected on these expansion slots. These are described in Table 1 and Table 6.

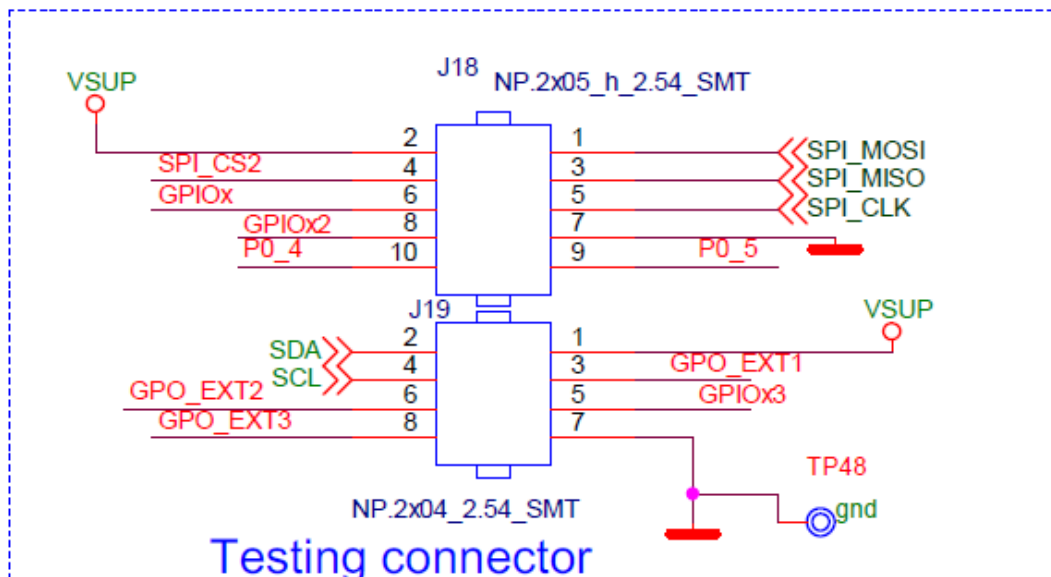

Figure 10: Schematic of Expansion Slots

5.8 Accelerometer/Gyroscope Sensor

The DA14585 IoT MSK employs the ICM42605 motion sensor from TDK Invensense that combines a 3-axis gyroscope and a 3-axis accelerometer.

The ICM42605 features a 2 kB FIFO memory that can reduce the traffic on the serial bus interface and thus reduce power consumption, allowing the system processor to burst read sensor data and then go into a low-power mode.

The gyroscope supports eight independently-programmable full-scale range settings from ± 15.625 dps to ± 2000 dps, and the accelerometer supports four independently programmable full-scale range settings from ± 2 g to ± 16 g.

In full operation mode with the accelerometer and gyroscope enabled, the current consumption is typically 0.72 mA, while it drops down to 11 μ A in sleep mode.

The ICM42605 module is connected to DA14585 via an SPI interface which supports speeds up to 24 MHz.

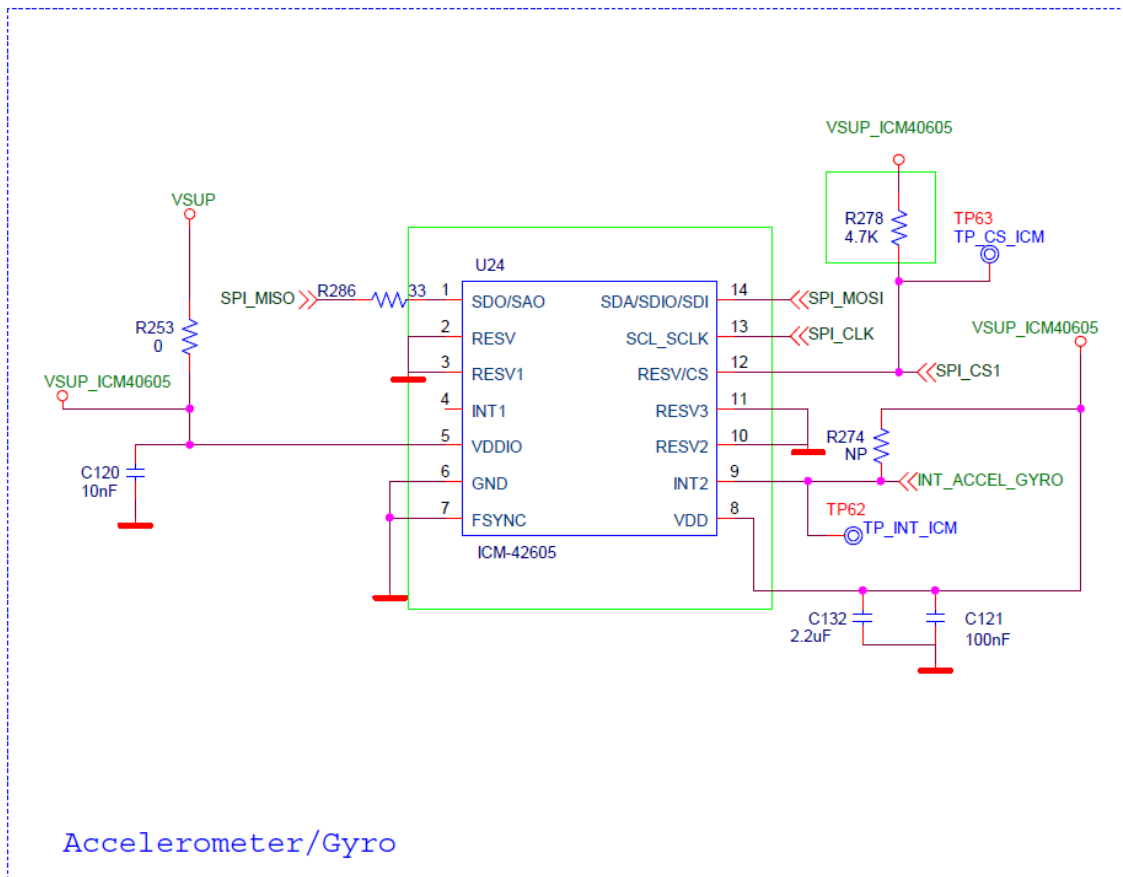

Figure 11: Schematic of ICM42605 Motion Sensor

Table 7: Indicative Electrical Characteristics of ICM42605 Motion Sensor

Parameter	Min	Typ	Max	Unit
Supply Voltage (VDD)	1.71	1.8	3.6	V
Supply Voltage (VDD I/O)	1.71	1.8	3.6	V
Supply Currents				
6-Axis Gyroscope Multi Sensor Accelerometer		0.72		mA
3-Axis Accelerometer		0.24		mA
3-Axis Gyroscope		0.57		mA
Sleep mode		11		uA
Temperature				
Operating Temperature	-40		85	°C

5.8.1 Additional (Non-Populated) Motion Sensor

For additional flexibility, the DA14585 IoT MSK is equipped with an additional PCB footprint (U11 as shown in Figure 24) of an alternative accelerometer/gyroscope sensor. This corresponds to the part number BMI160 of gyroscope/accelerometer from Bosch Sensortec. The SPI bus is shared with the

TDK sensor, meaning that ICM42605 along with its peripheral passive components have to be unsoldered before using BMI160.

Table 8: Motion Sensor Mounting Scenarios

BMI160 as Motion Sensor		ICM42605 as Motion Sensor	
BMI160	Mounted	BMI160	Not mounted
R283,R127,R282 C36,C37	Mounted	R283,R127,R282 C36,C37	Not mounted
ICM42605	Not mounted	ICM42605	Mounted
R253,R286,R278 C120,C121,C132	Not mounted	R253,R286,R278 C120,C121,C132	Mounted

5.9 Ambient Light and IR Proximity Sensor

The DA14585 IoT MSK has an ambient light and IR proximity sensor from Vishay, the [VCNL4010](#), on board. This particular sensor is fully integrated as the IR LED emitter is included in the package. This optical sensor is connected to DA14585 via the I2C interface.

Potential applications include:

- Display contrast/brightness control
- Proximity switch for consumer electronics, display, and devices
- Dimming control

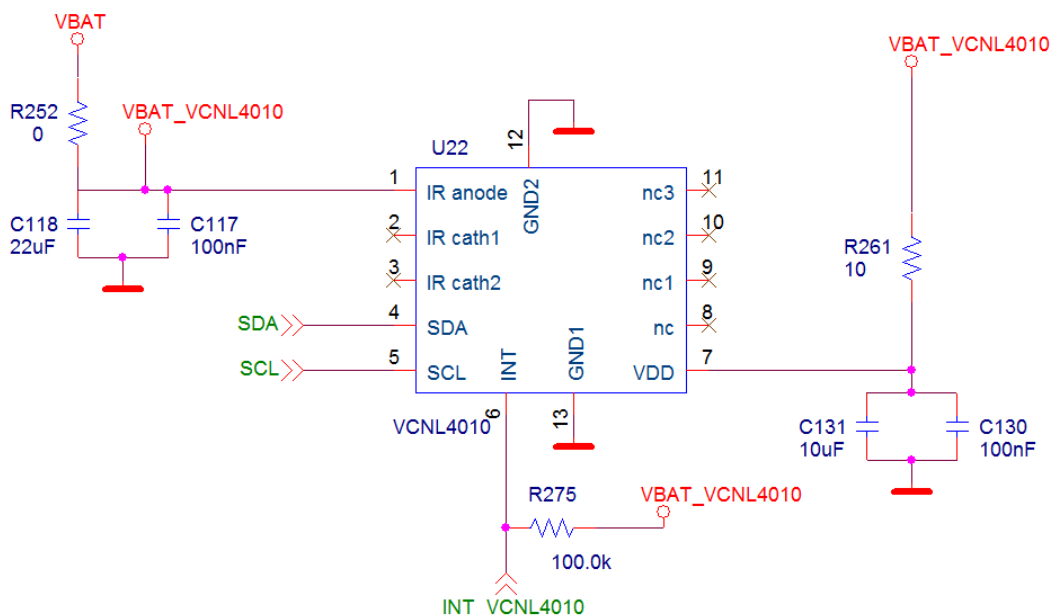

Figure 12: Schematic of the Ambient Light and IR Proximity Sensor

Table 9: Indicative Electrical Characteristics of VCNL4010 ALS and IR Sensor

Parameter	Min	Typ	Max	Unit
Supply Voltage (VDD)	2.5		3.6	V
Supply Voltage IR Anode	2.5		3.6	V
Supply currents IR mode (Indicative)				
2 measurements per second, IRED current 20 mA		5		uA
250 measurements per second, IRED current 20 mA		520		uA
Supply currents IR mode (Indicative)				
2 measurements per second averaging = 1		2.5		uA
8 measurements per second averaging = 1		10		uA
Standby current consumption		1.5	2	uA
Ambient light resolution				
Digital resolution (LSB count)		0.25		lx
Temperature				
Operating Temperature	-40		85	°C

Note 5 As can be noted from the table above, this particular sensor operates with a minimum battery voltage of 2.5 V, therefore battery level warnings will appear on the Android application at the sensor readings when the battery level reach the minimum voltage threshold level.

5.10 Buzzer

The DA14585 IoT MSK employs the [CSS-14B20-SMT](#) magnetic buzzer transducer from CUI INC. The buzzer is driven by the P2_8 GPIO via a transistor switch. [Figure 14](#) shows the frequency response versus dB magnitude of the buzzer, with the largest magnitude being approximately 2.2 KHz.

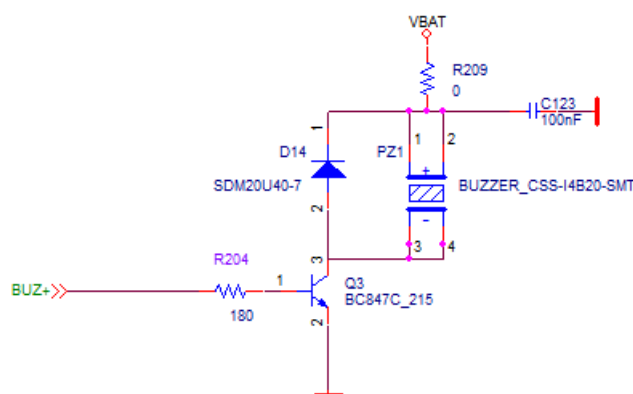

Figure 13: Buzzer Schematic

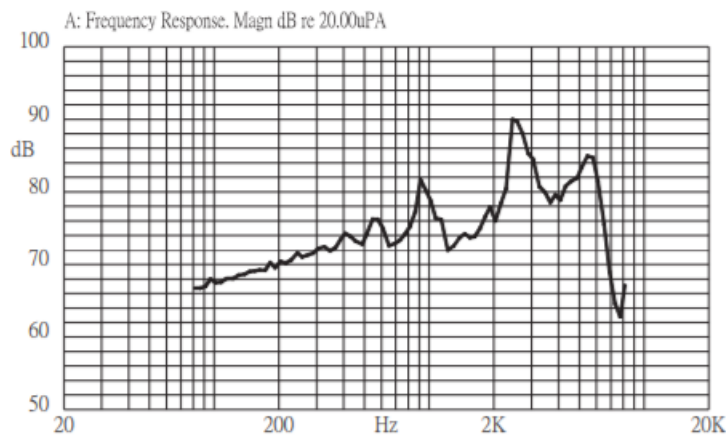

Figure 14: Frequency Response versus dB Magnitude

5.11 Electronic Compass (Magnetometer)

The DA14585 IoT MSK employs an electronic compass (magnetometer) sensor from Asahi Kasei, the [AK09915C](#). It incorporates:

- A magnetic sensor for detecting terrestrial magnetism in the X-axis, Y-axis, and Z-axis
- A sensor driving circuit
- A signal amplifier chain
- An arithmetic circuit for processing signals from each sensor off-loading the main processing unit
- Self-test function

The magnetic sensor is connected to the DA14585 via an SPI interface.

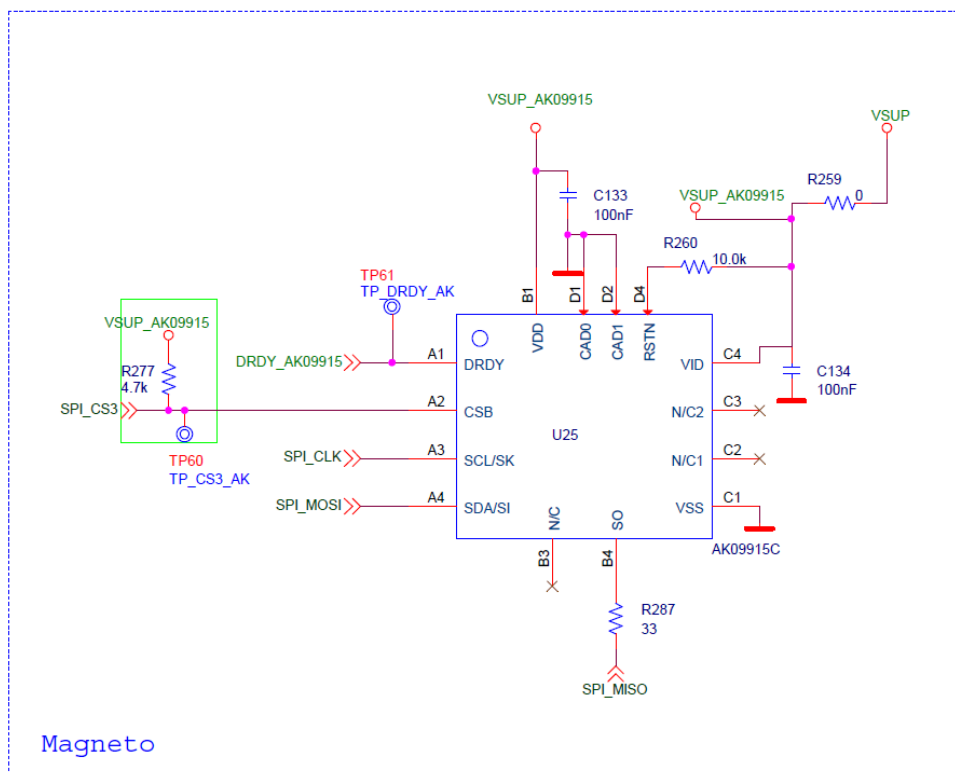

Figure 15: Schematic of the Magnetic Sensor

Table 10: Indicative Electrical Characteristics of AK09915C Magnetic Sensor

Parameter	Min	Typ	Max	Unit
Supply Voltage (VDD)	1.7	3.0	3.6	V
Supply Voltage (VDD I/O)	1.65	3.0	3.6	V
Supply currents				
When magnetic sensor is driven		2.1	3.5	mA
Self-test mode3-Axis Accelerometer		0.27	0.35	mA
Power down mode		3	6	uA
Temperature				
Operating Temperature	-30		85	°C

5.12 Environmental and Gas Sensor

The DA14585 IoT MSK employs the [BME680](#) from Bosch Sensortec to detect environmental changes such as temperature, humidity, atmospheric pressure, and as well as e-CO₂. This highly compacted sensor is suitable for monitoring indoor air quality and can detect air contamination from paint, furniture, garbage, and others using volatile oxide compounds (VOC) levels. From the VOC readings, two air quality parameters can be displayed using smart algorithms: the indoor air quality index (IAQ) and the e-CO₂. This sensor is connected to DA14585 via an I2C interface.

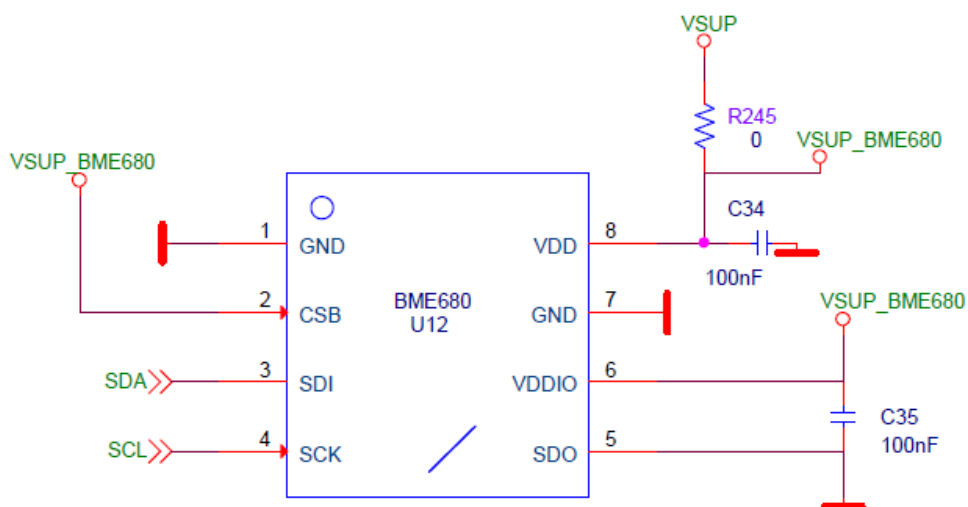

Figure 16: Schematic of the Environmental and Gas Sensor

Table 11: Indicative Electrical Characteristics of BME680

Parameter	Min	Typ	Max	Unit
Supply Voltage (VDD)	1.71	1.8	3.6	V
Supply Voltage (VDD I/O)	1.2	1.6	3.6	V
Supply Currents				
Current consumption during humidity measurement		340	450	uA
Current consumption during pressure measurement		714	849	uA
Current consumption during temperature measurement		350		uA
Current consumption during gas measurement		0.9		mA
Current consumption during gas measurement, continuous mode		12		mA
Sleep current		0.15	1	uA
Temperature				
Operating Temperature	-40		85	°C

5.13 Barometric Pressure Sensor

The DA14585 IoT MSK employs a high-accuracy, low-power, and waterproof barometric pressure sensor from TDK InvenSense, [ICP10100](#), for atmospheric pressure detection. This barometric pressure sensor is connected to DA14585 via an I2C interface, although it is not mounted on this reference design (non-populated). This additional barometric pressure sensor is not supported by the software reference applications provided with the DA14585 IoT MSK, and users who would like to use this sensor need to do the soldering themselves.

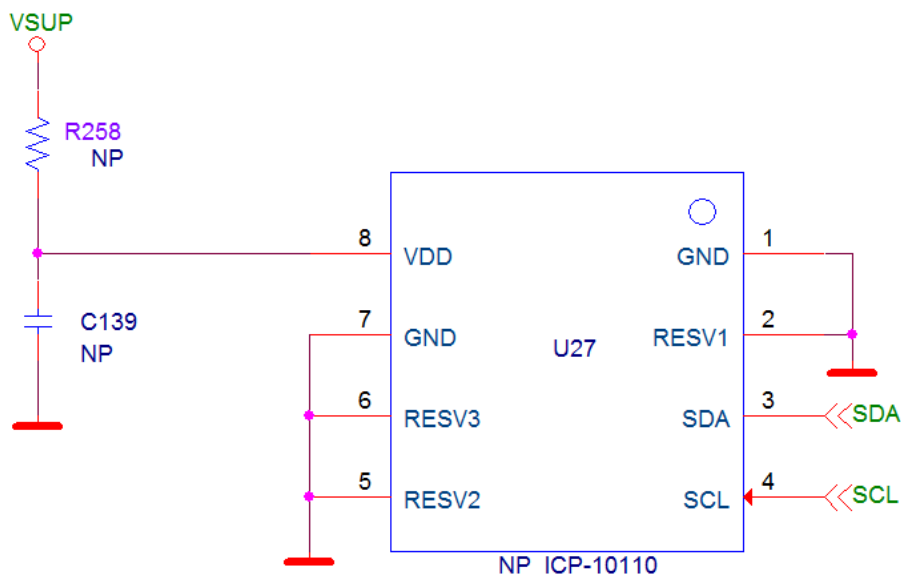

Figure 17: Schematic of Barometric Sensor

Table 12: Indicative Electrical Characteristics of ICP10110

Parameter	Min	Typ	Max	Unit
Supply Voltage (VDD)	1.71	1.8	1.89	V
Supply currents				
Idle state		1.0	2.5	µA
Measurement		210	300	µA
Temperature				
Operating Temperature	-40		85	°C

5.14 System Power Supply Options

5.14.1 Battery Power Options

Figure 18 shows that the DA14585 IoT MSK can choose power supply between batteries and JTAG supply using the two-position ON/OFF switch (SW2).

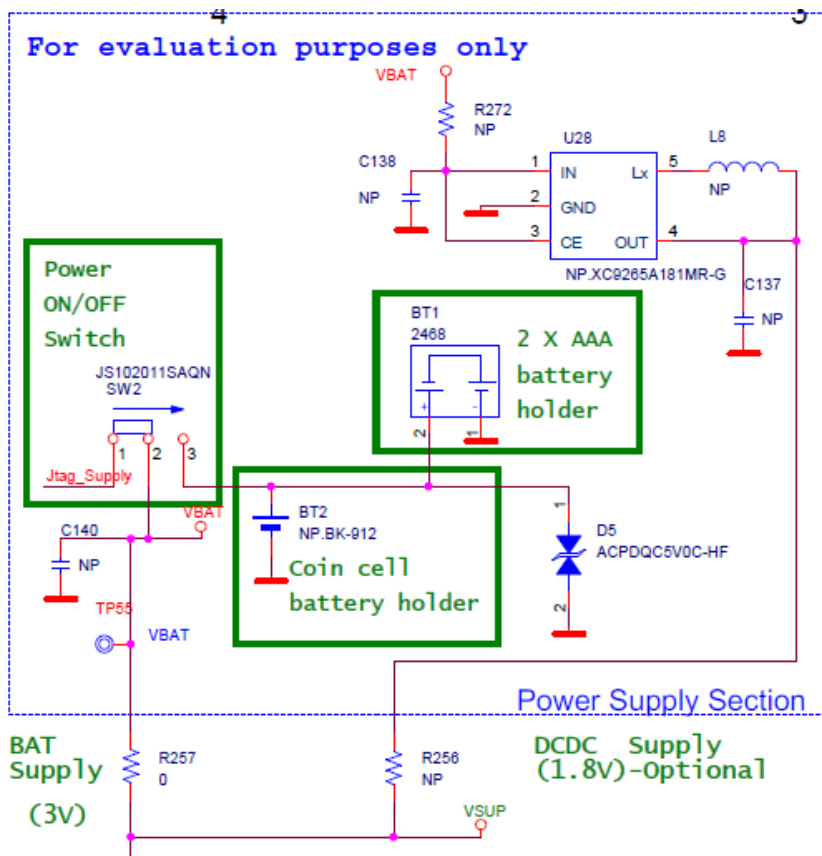

Figure 18: Power ON/OFF Switch and Power Options

The default power option for this development kit is to use two AAA batteries in the battery holder (BT1) to supply a 3 V voltage. In addition, the DA14585 MSK has an additional optional 3 V coin cell battery holder, although this battery holder (BT2) is not mounted on this reference design.

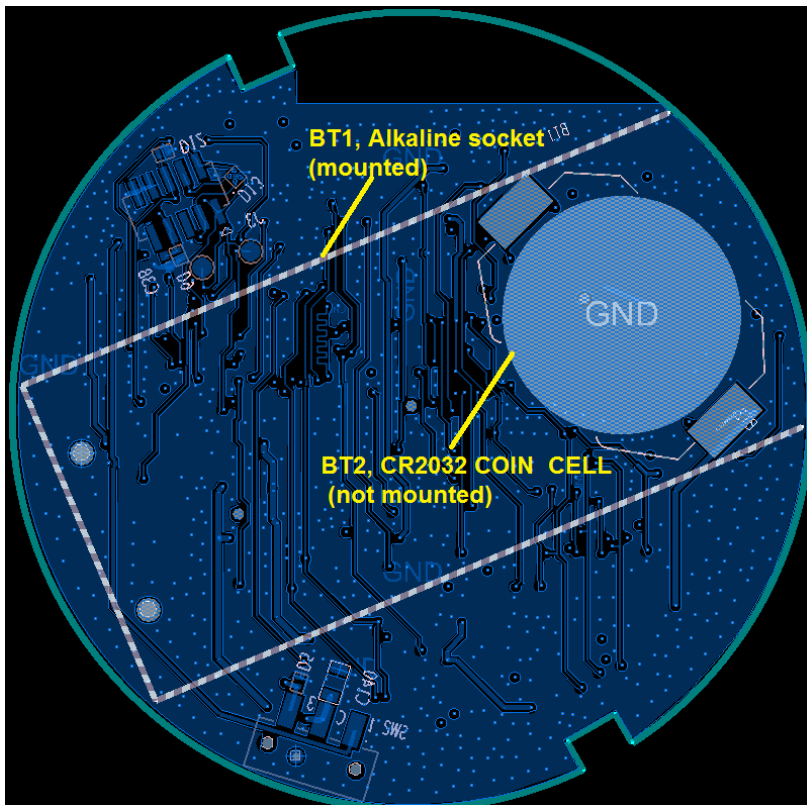

Figure 19: BT2, Coin Cell Battery Holder Position

5.14.2 Alternative Power Options

Alternatively, the DA14585 IoT MSK can be powered by an external DCDC converter, [XC9265A181MR](#) from Torex. The input voltage comes directly from the battery input and the output of this particular DCDC converter is fixed to 1.8 V. This power option is deactivated by default. To activate this power option, users should mount the U28 circuitry, resistors R272 and R256 while dismount R257, as presented in [Figure 22](#).

5.15 Printed Antennas

Printed antennas are of low cost, easy to manufacture, and able to provide diversity in polarization.

The antenna used in this reference design is based on [2]. [Figure 21](#) shows the directional dependence of the antenna (radiation pattern) of the printed IFA used in DA14585 IoT MSK.

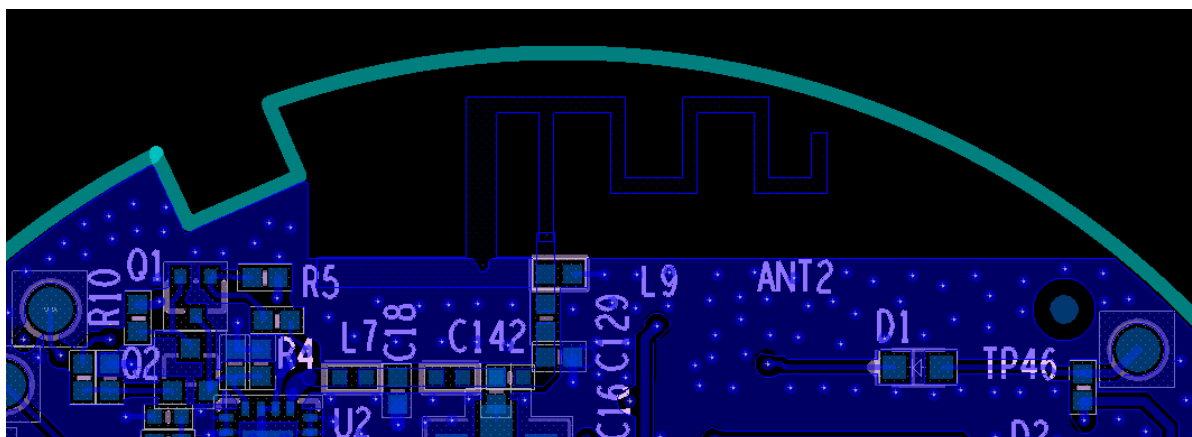

Figure 20: The Printed IFA of a Reduced Size on PCB

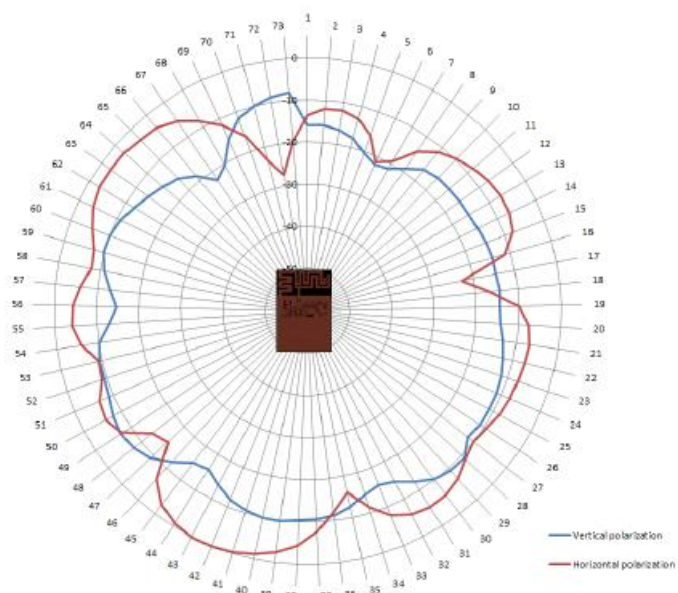

Figure 21: Radiation Pattern of the Printed IFA of a Reduced Size

6 Schematics

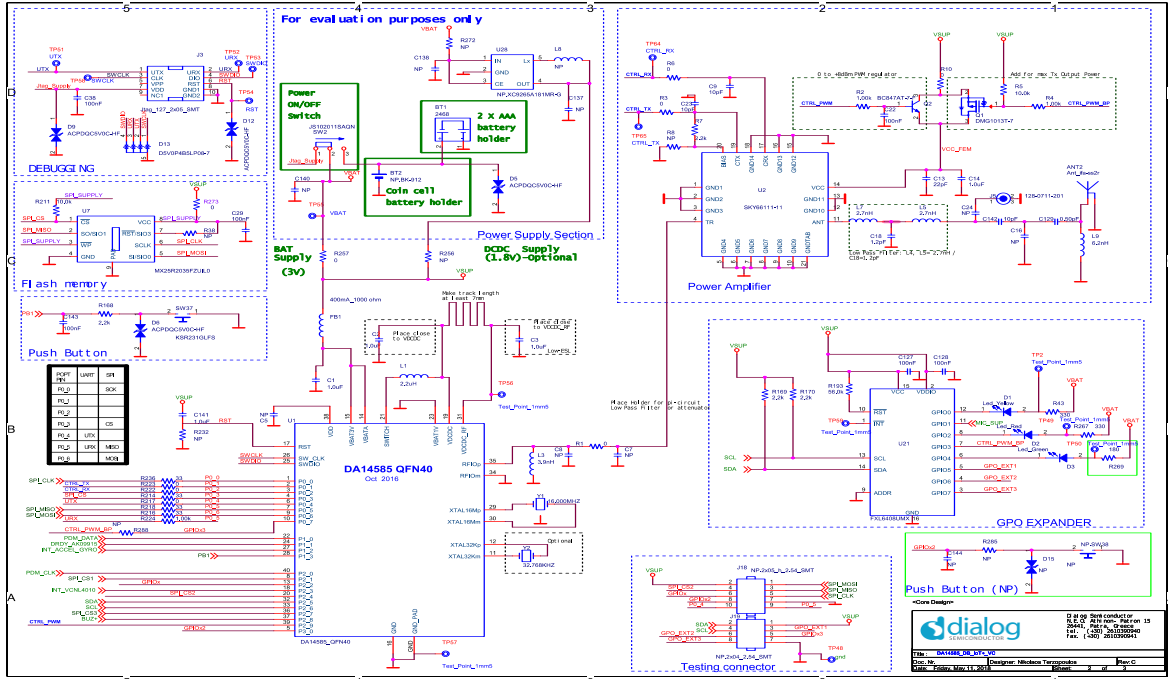

Figure 22: Schematic 1 of DA14585 IoT MSK

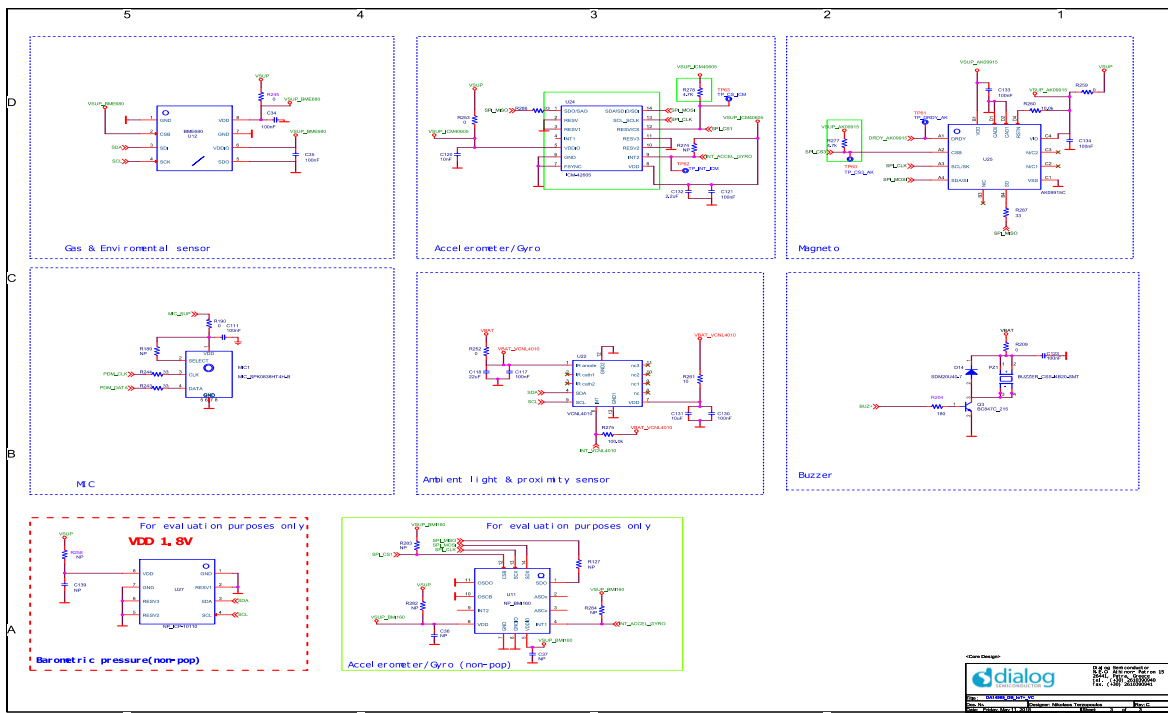

Figure 23: Schematic 2 of DA14585 IoT MSK

7 PCB Layout

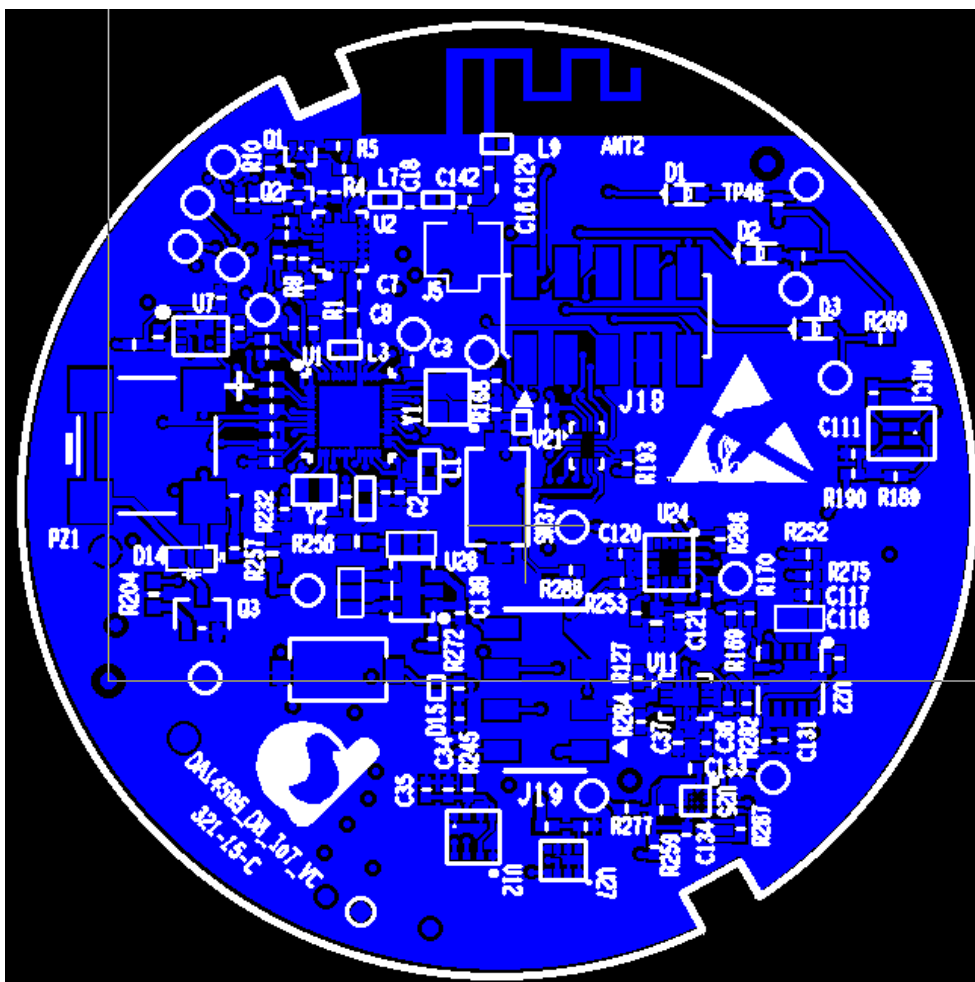

Figure 24: PCB of the DA14585 IoT MSK: Top View

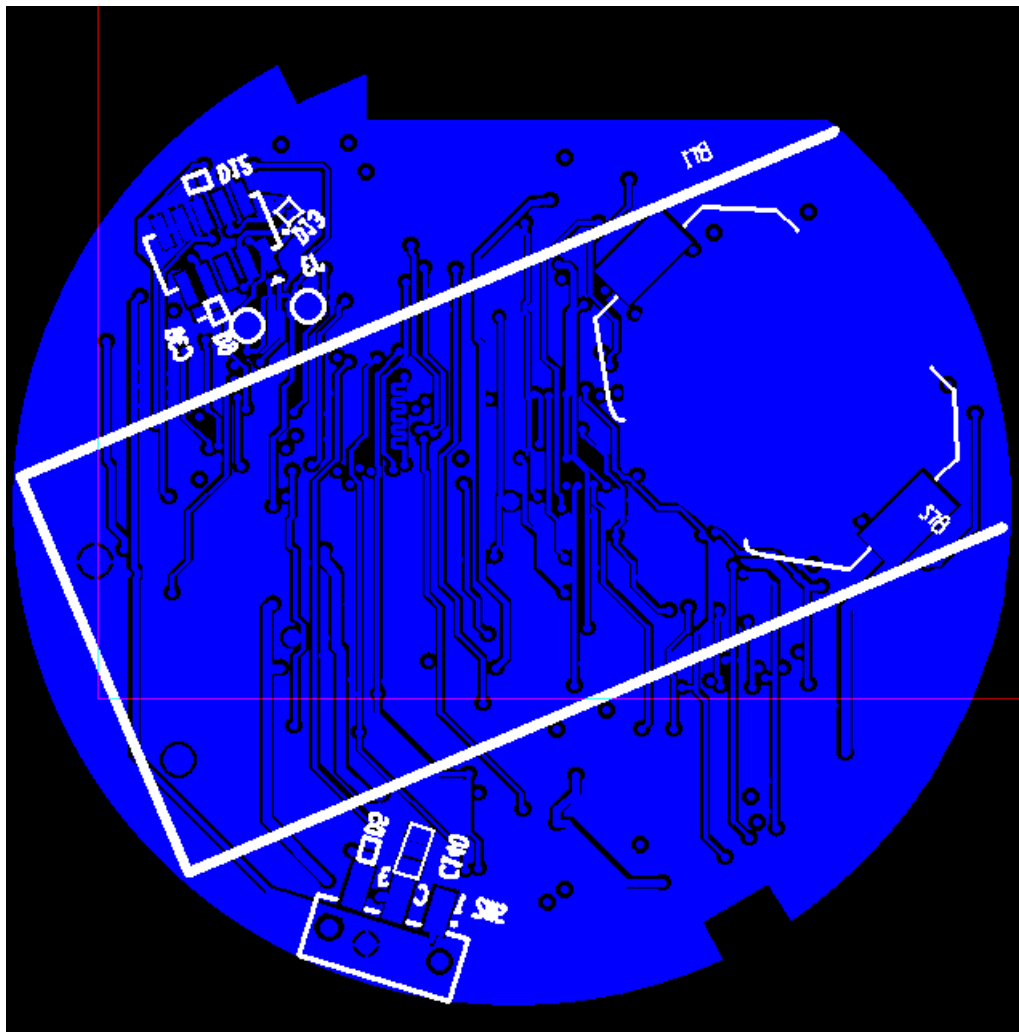

Figure 25: PCB of DA14585 IoT MSK: Bottom View

8 Power Measurements

The following figures outline a series of power consumption measurements done on DA14585 MSK. Several scenarios were tested to provide some indicative power consumption figures. In these measurements the PA remains in bypass mode.

Figure 26 illustrated the power consumption of DA14585 IoT MSK when all the sensors are in sleep mode, while DA14585 SoC is in advertise mode and not connected to any mobile devices. The spike seen is from LED blinking. The average power consumption at sleep mode is 18.63 μA .

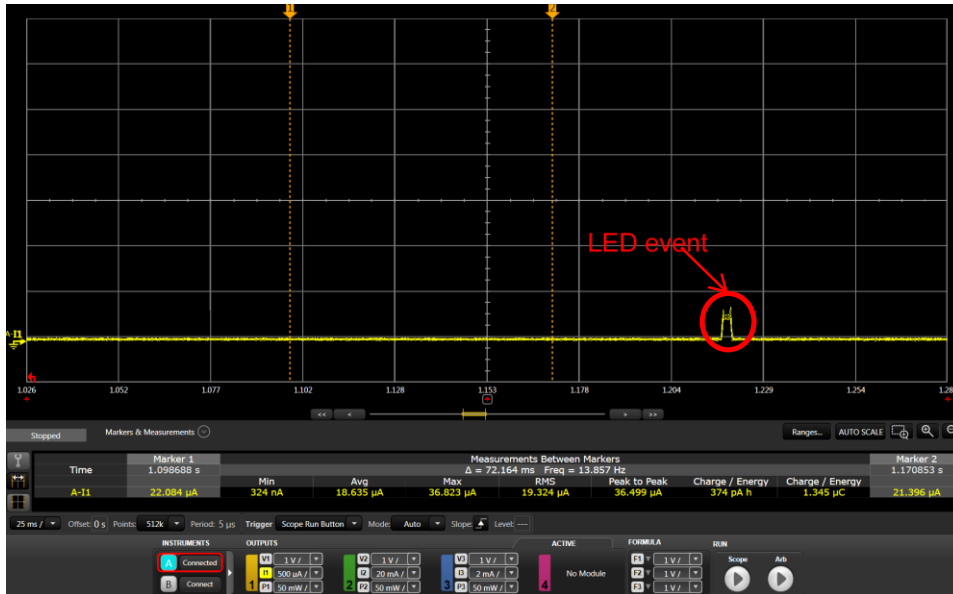

Figure 26: DA14585 Disconnected, All Sensors in Sleep Mode

Figure 27 shows the average power consumption with all sensors active and DA14585 IoT MSK in connected mode is 2.74 mA. DA14585 IoT MSK in connected mode means that it is connected with a mobile device which is providing the sensor reading to the user. With the gas sensor on, the total power consumption is approximately 14 mA.

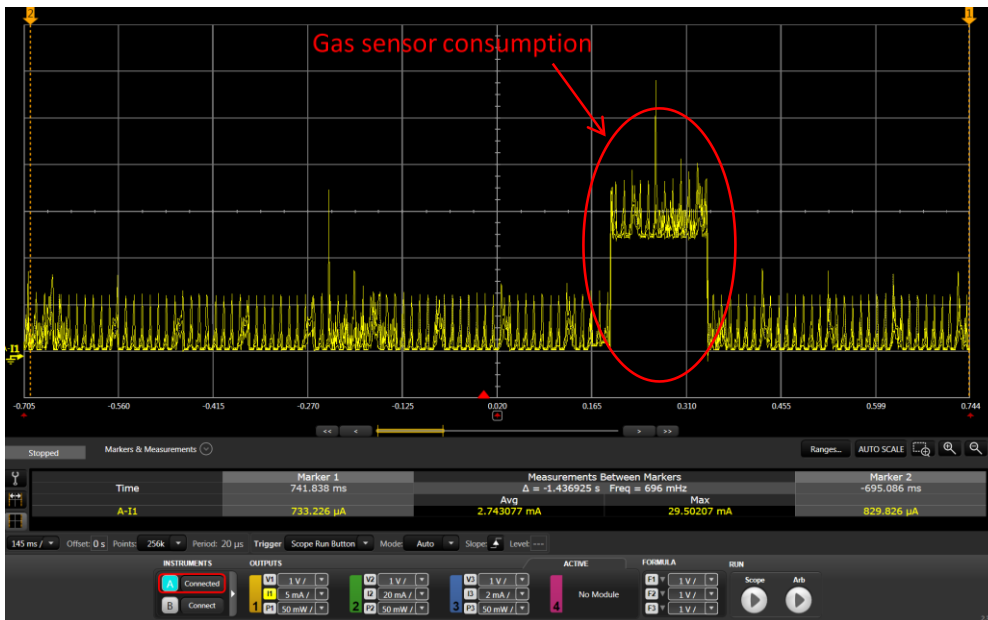

Figure 27: DA14585 Connected, All Sensors Active

Figure 28 shows the power consumption when DA14585 IoT MSK is set in connected mode with the gas sensor turned off. The average power consumption drops to 1.47 mA.

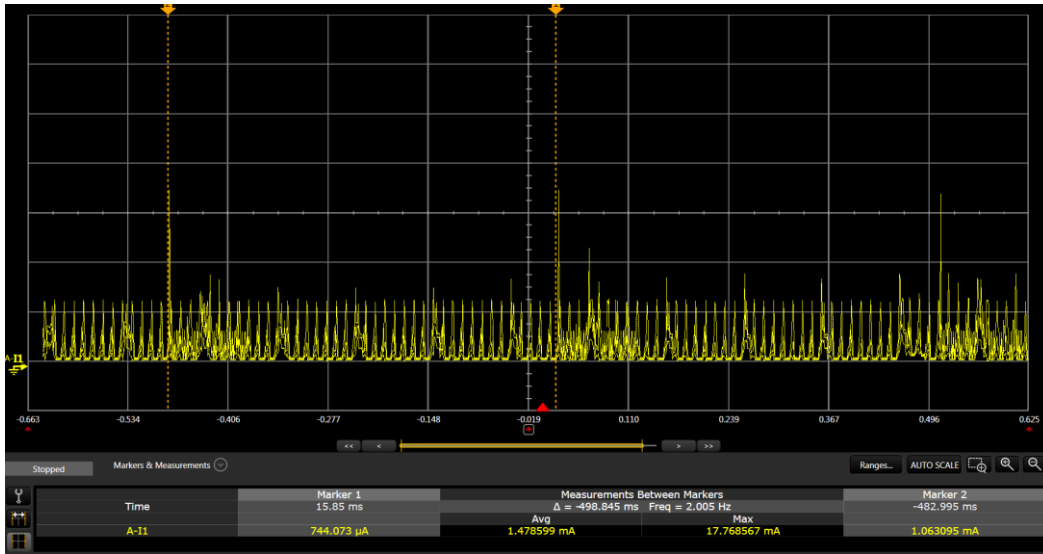

Figure 28: DA14585 Connected, Gas Sensor Off Only

Figure 29 illustrates the power consumption when DA14585 IoT MSK is set in connected mode with all sensors except the environmental and gas sensor on. Compared to Figure 28, the average power consumption has been slightly decreased by 200 nA down to 1.45 mA, indicating the very low power consumption of the environmental sensor.

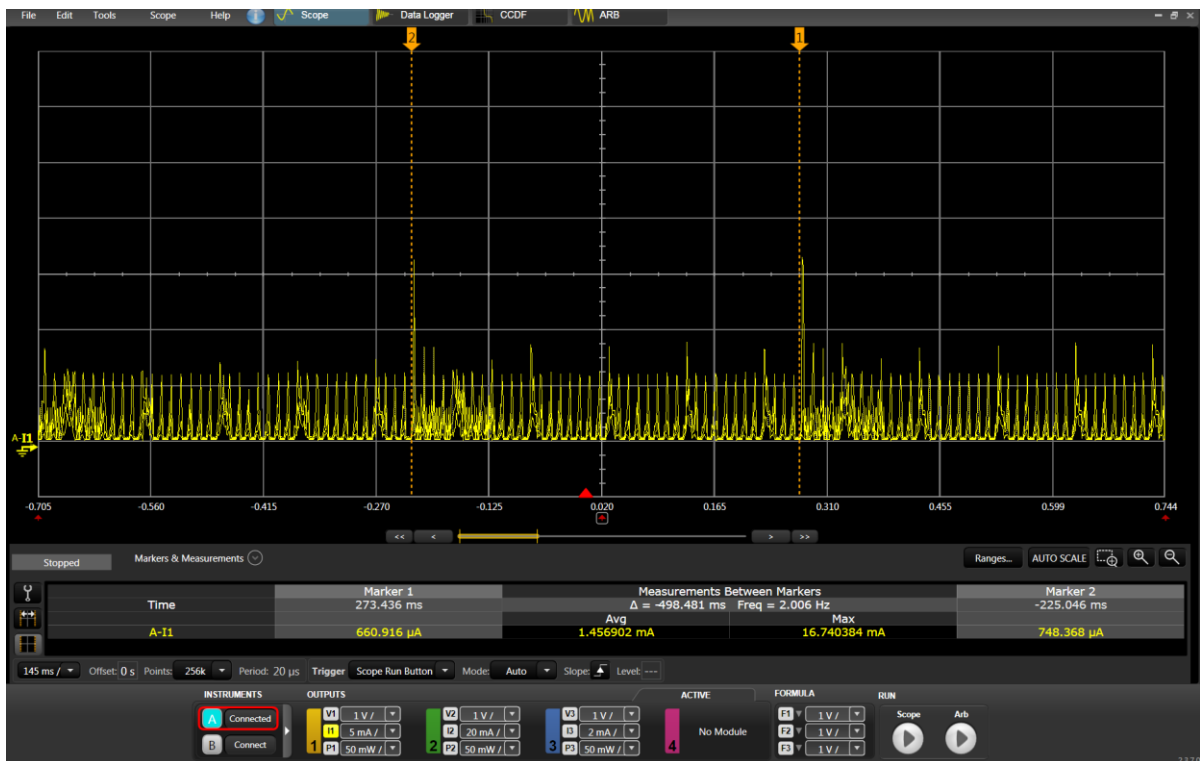

Figure 29: DA14585 Connected, Environmental and Gas Sensor OFF

Figure 30 shows that when DA14585 IoT MSK is set in connected mode with only the motion and magnetometer sensors on, the average power consumption is 1.38mA.

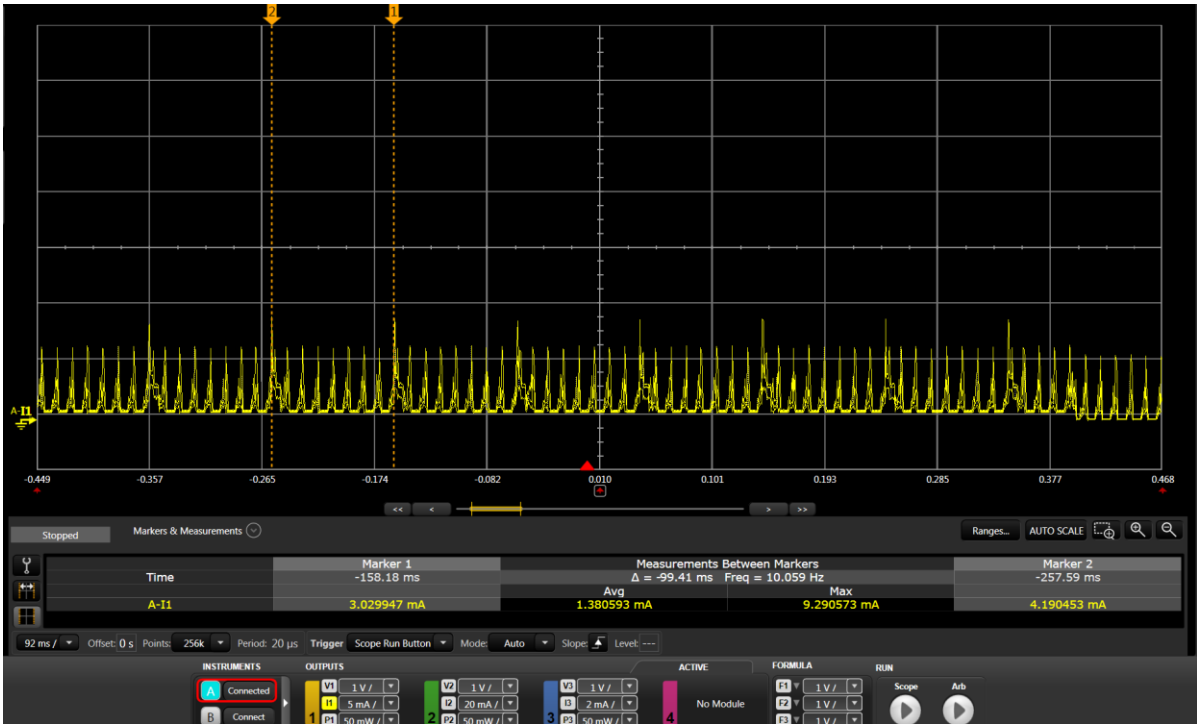

Figure 30: DA14585 Connected, Environmental, Gas, ALS and IR Sensors OFF

Finally, Figure 31 shows that when DA14585 IoT MSK is set on connected mode with only the motion sensor on, the average total power consumption is merely 440 μA.

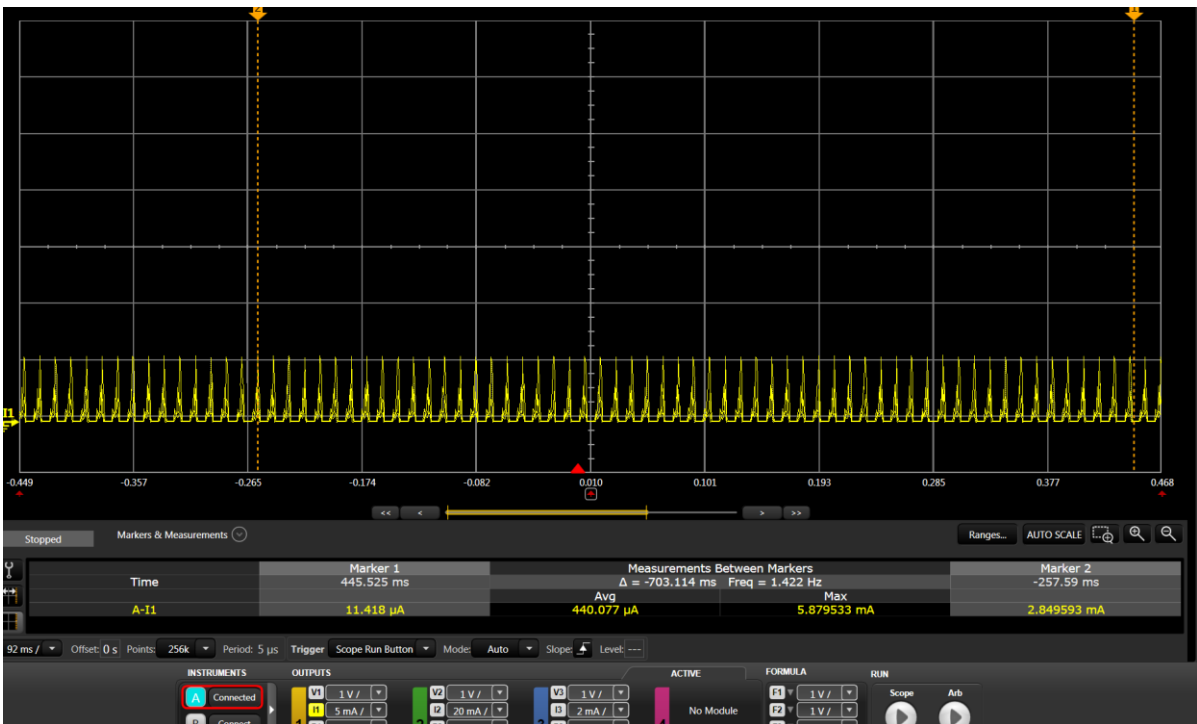

Figure 31: DA14585 Connected, Motion Sensor ON Only

Table 13 shows the power measurement results in tabular form.

Table 13: Collective Table for Current Measurement

Connection Mode	Active Sensors	Average Current Consumption Active (mA)	Average Current Consumption Sleep (µA)
Connected	All	2.74	
Connected	Gas off only	1.47	
Connected	Environmental and gas sensors off	1.45	
Connected	Environmental and gas sensors, ALS, and IR sensors off	1.38	
Connected	Only motion sensor ON	0.440	
Disconnected, sleep mode	off		18.63

9 Enclosure

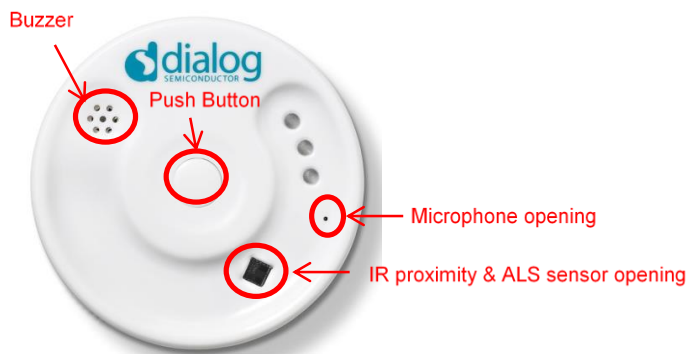

Figure 32: DA14585 IoT MSK Enclosure: Top View

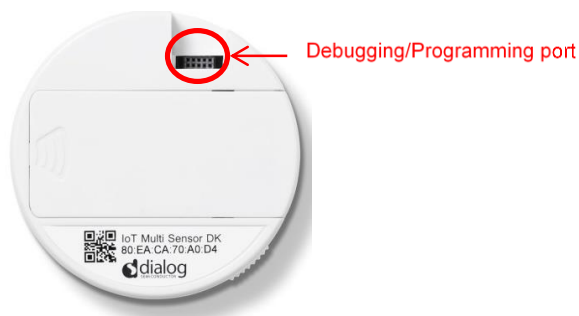

Figure 33: DA14585 IoT MSK Enclosure: Bottom View



Figure 34: DA14585 IoT MSK Enclosure: Side View

9.1 Adjust IR Proximity Sensor Performance inside the Enclosure

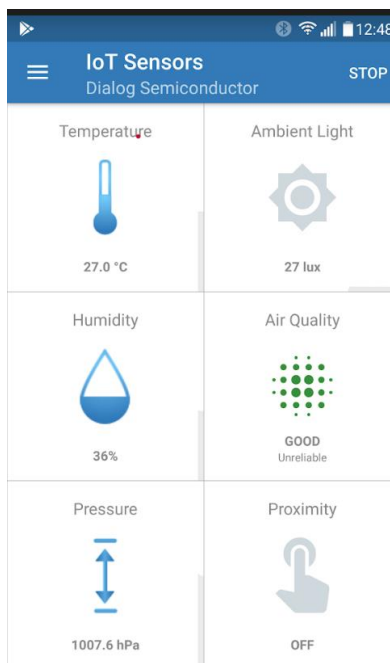

Figure 35: Reading Panel of Dialog IoT Sensors App

Once the PCBA board of DA14585 IoT MSK is placed inside the enclosure, the proximity readings from the ALS and IR proximity sensor need to be adjusted to the lighting constraints imposed by the enclosure and it can be done by the Dialog IoT Sensors app that accompanies DA14585 IoT MSK.

Figure 35 shows the front app panel of various sensor readings after the app is connected to DA14585 IoT MSK.

To adjust the ALS and IR proximity sensor, follow the following steps:

1. Press the “**STOP**” icon at the top right corner to stop all sensors.
2. Choose the menu at the top left corner, and the menu appears (Figure 36).
3. Choose “Settings” and the settings menu appears (Figure 37).
4. In the settings menu, choose “**Basic settings**” and scroll down to “**Reset to defaults**” (Figure 38). The values of the proximity hysteresis have now been adjusted for proper IR proximity functionality.

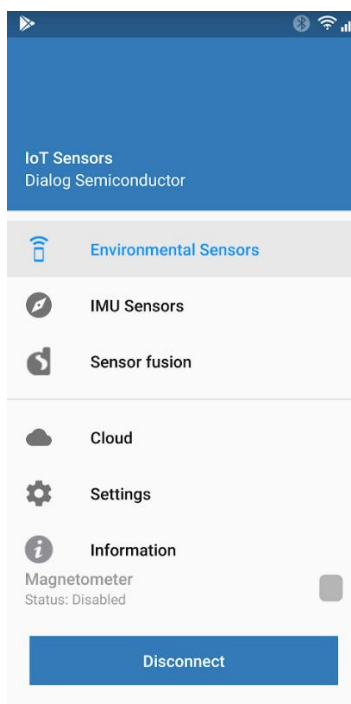

Figure 36: Menu Panel of Dialog IoT Sensors APP

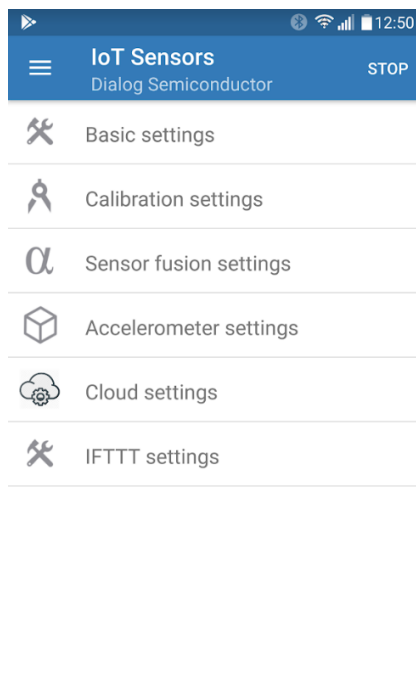

Figure 37: Settings Menu of Dialog IoT Sensors App

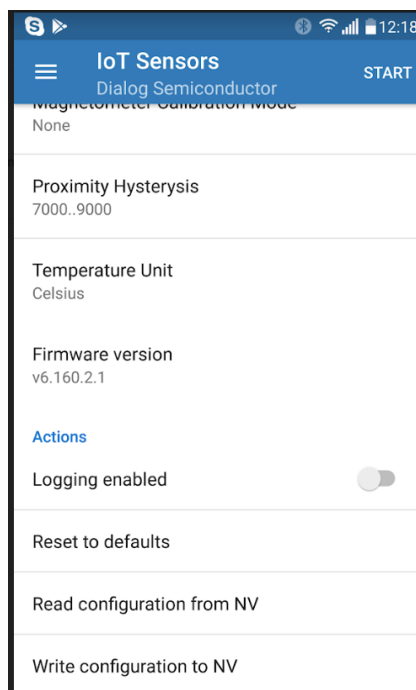

Figure 38: Choices of Basic Settings in Dialog IoT Sensors App

10 Configuration of the Debugging Interface

The DA14585 IoT MSK has a dedicated debugging port (Figure 33), which can be used by both JTAG and UART debugging ports on DA14585 SoC.

The USB-to-JTAG and USB-to-UART functions are implemented by an external Communication Interface Board (CIB) shown in Figure 39. This CIB has a SEGGER chip running the JLink-OB firmware.

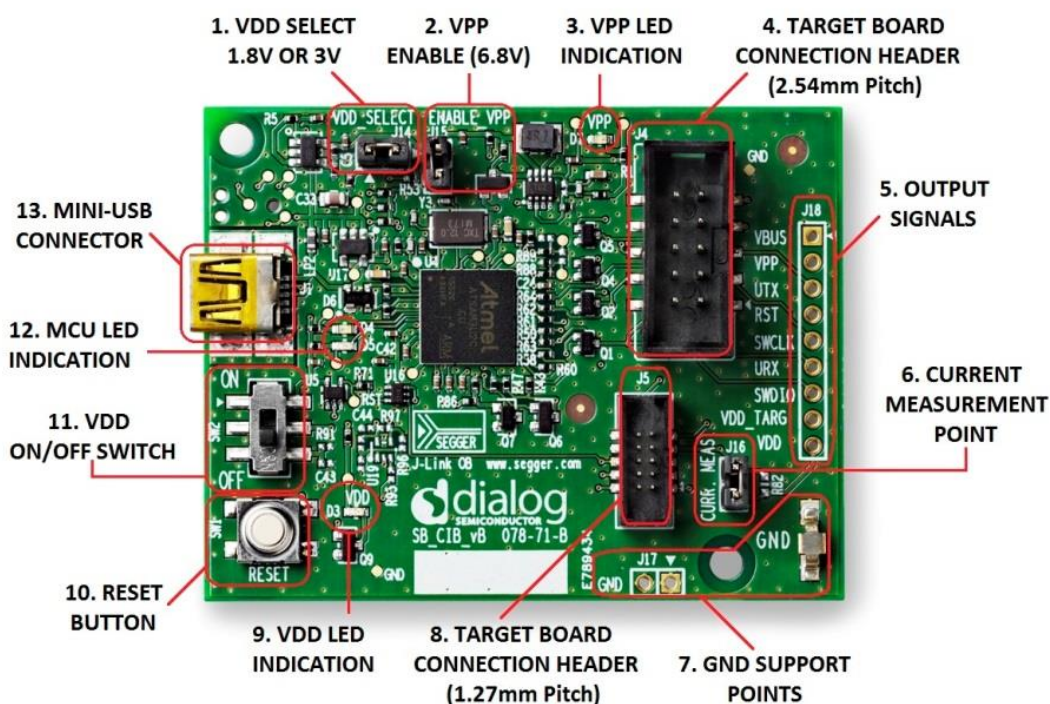

Figure 39: Communication Interface Board (CIB)

The CIB performs the following functions:

- Connecting the PC to the DA14585 JTAG port, or
- Connecting PC to the DA14585 UART port (full UART is possible but it shall be enabled on the PC driver)
- Hardware RESET capability. Note that the RESET signal is active high.

Users should enforce the following on-board settings (Figure 39) to program/debug the DA14585 IoT MSK board:

- Set the ON/OFF switch (11) of the CIB to ON to power the DA14585 IoT MSK from the CIB
- Connect the USB cable to the mini USB connector (13)
- Connect an IDC-10 cable to the 1.27 mm pitch header (8) on the CIB
- Connect the other end of the IDC-10 cable to the debugging port on the bottom of the DA14585 IoT MSK
- Populate the jumper at J16 header (6)

The connection between the CIB and DA14585 IoT MSK is shown in Figure 40.



Figure 40: Connection between DA14585 IoT MSK and the CIB

Note 6 During programming/debugging, the ON/OFF switch should be set at OFF to have the DA14585 IoT MSK powered by JTAG, because users should program the development kit or download the firmware via the CIB without the two AAA batteries.

Revision History

Revision	Date	Description
1.2	23-Feb-2022	Updated logo, disclaimer, copyright.
1.1	06-Aug-2018	Added section 9.1
1.0	03-Aug-2018	Initial version.

Status Definitions

Status	Definition
DRAFT	The content of this document is under review and subject to formal approval, which may result in modifications or additions.
APPROVED or unmarked	The content of this document has been approved for publication.