

To our customers,

Old Company Name in Catalogs and Other Documents

On April 1st, 2010, NEC Electronics Corporation merged with Renesas Technology Corporation, and Renesas Electronics Corporation took over all the business of both companies. Therefore, although the old company name remains in this document, it is a valid Renesas Electronics document. We appreciate your understanding.

Renesas Electronics website: <http://www.renesas.com>

April 1st, 2010
Renesas Electronics Corporation

Issued by: Renesas Electronics Corporation (<http://www.renesas.com>)

Send any inquiries to <http://www.renesas.com/inquiry>.

Notice

1. All information included in this document is current as of the date this document is issued. Such information, however, is subject to change without any prior notice. Before purchasing or using any Renesas Electronics products listed herein, please confirm the latest product information with a Renesas Electronics sales office. Also, please pay regular and careful attention to additional and different information to be disclosed by Renesas Electronics such as that disclosed through our website.
2. Renesas Electronics does not assume any liability for infringement of patents, copyrights, or other intellectual property rights of third parties by or arising from the use of Renesas Electronics products or technical information described in this document. No license, express, implied or otherwise, is granted hereby under any patents, copyrights or other intellectual property rights of Renesas Electronics or others.
3. You should not alter, modify, copy, or otherwise misappropriate any Renesas Electronics product, whether in whole or in part.
4. Descriptions of circuits, software and other related information in this document are provided only to illustrate the operation of semiconductor products and application examples. You are fully responsible for the incorporation of these circuits, software, and information in the design of your equipment. Renesas Electronics assumes no responsibility for any losses incurred by you or third parties arising from the use of these circuits, software, or information.
5. When exporting the products or technology described in this document, you should comply with the applicable export control laws and regulations and follow the procedures required by such laws and regulations. You should not use Renesas Electronics products or the technology described in this document for any purpose relating to military applications or use by the military, including but not limited to the development of weapons of mass destruction. Renesas Electronics products and technology may not be used for or incorporated into any products or systems whose manufacture, use, or sale is prohibited under any applicable domestic or foreign laws or regulations.
6. Renesas Electronics has used reasonable care in preparing the information included in this document, but Renesas Electronics does not warrant that such information is error free. Renesas Electronics assumes no liability whatsoever for any damages incurred by you resulting from errors in or omissions from the information included herein.
7. Renesas Electronics products are classified according to the following three quality grades: "Standard", "High Quality", and "Specific". The recommended applications for each Renesas Electronics product depends on the product's quality grade, as indicated below. You must check the quality grade of each Renesas Electronics product before using it in a particular application. You may not use any Renesas Electronics product for any application categorized as "Specific" without the prior written consent of Renesas Electronics. Further, you may not use any Renesas Electronics product for any application for which it is not intended without the prior written consent of Renesas Electronics. Renesas Electronics shall not be in any way liable for any damages or losses incurred by you or third parties arising from the use of any Renesas Electronics product for an application categorized as "Specific" or for which the product is not intended where you have failed to obtain the prior written consent of Renesas Electronics. The quality grade of each Renesas Electronics product is "Standard" unless otherwise expressly specified in a Renesas Electronics data sheets or data books, etc.

"Standard": Computers; office equipment; communications equipment; test and measurement equipment; audio and visual equipment; home electronic appliances; machine tools; personal electronic equipment; and industrial robots.

"High Quality": Transportation equipment (automobiles, trains, ships, etc.); traffic control systems; anti-disaster systems; anti-crime systems; safety equipment; and medical equipment not specifically designed for life support.

"Specific": Aircraft; aerospace equipment; submersible repeaters; nuclear reactor control systems; medical equipment or systems for life support (e.g. artificial life support devices or systems), surgical implantations, or healthcare intervention (e.g. excision, etc.), and any other applications or purposes that pose a direct threat to human life.

8. You should use the Renesas Electronics products described in this document within the range specified by Renesas Electronics, especially with respect to the maximum rating, operating supply voltage range, movement power voltage range, heat radiation characteristics, installation and other product characteristics. Renesas Electronics shall have no liability for malfunctions or damages arising out of the use of Renesas Electronics products beyond such specified ranges.
9. Although Renesas Electronics endeavors to improve the quality and reliability of its products, semiconductor products have specific characteristics such as the occurrence of failure at a certain rate and malfunctions under certain use conditions. Further, Renesas Electronics products are not subject to radiation resistance design. Please be sure to implement safety measures to guard them against the possibility of physical injury, and injury or damage caused by fire in the event of the failure of a Renesas Electronics product, such as safety design for hardware and software including but not limited to redundancy, fire control and malfunction prevention, appropriate treatment for aging degradation or any other appropriate measures. Because the evaluation of microcomputer software alone is very difficult, please evaluate the safety of the final products or system manufactured by you.
10. Please contact a Renesas Electronics sales office for details as to environmental matters such as the environmental compatibility of each Renesas Electronics product. Please use Renesas Electronics products in compliance with all applicable laws and regulations that regulate the inclusion or use of controlled substances, including without limitation, the EU RoHS Directive. Renesas Electronics assumes no liability for damages or losses occurring as a result of your noncompliance with applicable laws and regulations.
11. This document may not be reproduced or duplicated, in any form, in whole or in part, without prior written consent of Renesas Electronics.
12. Please contact a Renesas Electronics sales office if you have any questions regarding the information contained in this document or Renesas Electronics products, or if you have any other inquiries.

(Note 1) "Renesas Electronics" as used in this document means Renesas Electronics Corporation and also includes its majority-owned subsidiaries.

(Note 2) "Renesas Electronics product(s)" means any product developed or manufactured by or for Renesas Electronics.

SuperH™ Family E10A Emulator

Additional Document for User's Manual

SH7618 E10A HS7618KCM02HE

Renesas Microcomputer

Development Environment

System

SuperH™ Family / SH7600 Series

Specific Guide for the SH7618

E10A Emulator

Cautions

Keep safety first in your circuit designs!

1. Renesas Technology Corp. puts the maximum effort into making semiconductor products better and more reliable, but there is always the possibility that trouble may occur with them. Trouble with semiconductors may lead to personal injury, fire or property damage. Remember to give due consideration to safety when making your circuit designs, with appropriate measures such as (i) placement of substitutive, auxiliary circuits, (ii) use of nonflammable material or (iii) prevention against any malfunction or mishap.

Notes regarding these materials

1. These materials are intended as a reference to assist our customers in the selection of the Renesas Technology Corp. product best suited to the customer's application; they do not convey any license under any intellectual property rights, or any other rights, belonging to Renesas Technology Corp. or a third party.
2. Renesas Technology Corp. assumes no responsibility for any damage, or infringement of any third-party's rights, originating in the use of any product data, diagrams, charts, programs, algorithms, or circuit application examples contained in these materials.
3. All information contained in these materials, including product data, diagrams, charts, programs and algorithms represents information on products at the time of publication of these materials, and are subject to change by Renesas Technology Corp. without notice due to product improvements or other reasons. It is therefore recommended that customers contact Renesas Technology Corp. or an authorized Renesas Technology Corp. product distributor for the latest product information before purchasing a product listed herein. The information described here may contain technical inaccuracies or typographical errors. Renesas Technology Corp. assumes no responsibility for any damage, liability, or other loss rising from these inaccuracies or errors. Please also pay attention to information published by Renesas Technology Corp. by various means, including the Renesas Technology Corp. Semiconductor home page (<http://www.renesas.com>).
4. When using any or all of the information contained in these materials, including product data, diagrams, charts, programs, and algorithms, please be sure to evaluate all information as a total system before making a final decision on the applicability of the information and products. Renesas Technology Corp. assumes no responsibility for any damage, liability or other loss resulting from the information contained herein.
5. Renesas Technology Corp. semiconductors are not designed or manufactured for use in a device or system that is used under circumstances in which human life is potentially at stake. Please contact Renesas Technology Corp. or an authorized Renesas Technology Corp. product distributor when considering the use of a product contained herein for any specific purposes, such as apparatus or systems for transportation, vehicular, medical, aerospace, nuclear, or undersea repeater use.
6. The prior written approval of Renesas Technology Corp. is necessary to reprint or reproduce in whole or in part these materials.
7. If these products or technologies are subject to the Japanese export control restrictions, they must be exported under a license from the Japanese government and cannot be imported into a country other than the approved destination. Any diversion or reexport contrary to the export control laws and regulations of Japan and/or the country of destination is prohibited.
8. Please contact Renesas Technology Corp. for further details on these materials or the products contained therein.

Contents

Section 1	Connecting the Emulator with the User System	1
1.1	Components of the Emulator	1
1.2	Connecting the E10A Emulator with the User System	2
1.3	Installing the H-UDI Port Connector on the User System	2
1.4	Pin Assignments of the H-UDI Port Connector	2
1.5	Recommended Circuit between the H-UDI Port Connector and the MPU	4
1.5.1	Recommended Circuit	4
Section 2	Specifications of the SH7618 E10A Emulator's Software	7
2.1	Differences between the SH7618 and the Emulator	7
2.2	Specific Functions for the SH7618 E10A Emulator	10
2.2.1	Emulator Driver Selection	10
2.2.2	Break Condition Functions	11
2.2.3	Trace Functions.....	12
2.2.4	Note on Using the JTAG Clock (TCK).....	13
2.2.5	Notes on Setting the [Breakpoint] Dialog Box	13
2.2.6	Notes on Setting the [Break Condition] Dialog Box and BREAKCONDITION_SET Command	14
2.2.7	Notes on Setting the UBC_MODE Command.....	14

Section 1 Connecting the Emulator with the User System

1.1 Components of the Emulator

The SH7618 E10A emulator supports the SH7618. Table 1.1 lists the components of the emulator.

Table 1.1 Components of the Emulator (HS7618KCM01H or HS7618KCI01H)

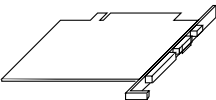
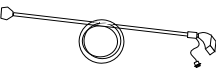
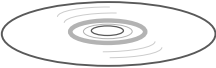
Classification	Component	Appearance	Quantity	Remarks
Hardware	Card emulator	 (PCMCIA)	1	HS7618KCM01H (PCMCIA: 14-pin type): Depth: 85.6 mm, Width: 54.0 mm, Height: 5.0 mm, Mass: 27.0 g HS7618KCI01H (PCI: 14-pin type): Depth: 144.0 mm, Width: 105.0 mm, Mass: 93.0 g
		or  (PCI)		
	User system interface cable		1	HS7618KCM01H (PCMCIA: 14-pin type): Length: 80 cm, Mass: 45.0 g HS7618KCI01H (PCI: 14-pin type): Length: 150 cm, Mass: 86.0 g
Software	SH7618 E10A emulator setup program, SuperH™ Family E10A Emulator User's Manual, and Specific Guide for the SH7618 E10A Emulator		1	HS7618KCM01SR, HS0005KCM01HJ, HS0005KCM01HE, HS7618KCM02HJ, and HS7618KCM02HE (provided on a CD-R)

1.2 Connecting the E10A Emulator with the User System

To connect the E10A emulator (hereinafter referred to as the emulator), the H-UDI port connector must be installed on the user system to connect the user system interface cable. When designing the user system, refer to the recommended circuit between the H-UDI port connector and the MCU. In addition, read the E10A emulator user's manual and hardware manual for the related device.

Table 1.2 shows the type number of the E10A emulator and the corresponding connector type.

Table 1.2 Type Number and Connector Type

Type Number	Connector
HS7618KCM01H, HS7618KCI01H	14-pin connector

1.3 Installing the H-UDI Port Connector on the User System

Table 1.3 shows the recommended H-UDI port connectors for the emulator.

Table 1.3 Recommended H-UDI Port Connectors

Connector	Type Number	Manufacturer	Specifications
14-pin connector	2514-6002	Minnesota Mining & Manufacturing Ltd.	14-pin straight type

Note: Do not install any components within 3 mm of the H-UDI port connector.

1.4 Pin Assignments of the H-UDI Port Connector

Figure 1.1 shows the pin assignments of the H-UDI port connector.

Note: Note that the pin number assignments of the H-UDI port connector shown below differ from those of the connector manufacturer.

Pin No.	Signal	Input/ Output*1	SH7618 Pin No.	Note
1	TCK	Input	N10	
2*2	/TRST	Input	M11	
3	TDO	Output	N11	
4	Not connected	—	—	
5	TMS	Input	P11	
6	TDI	Input	R11	
7*2	/RES	Output	R12	
11	Not connected	—	—	
8 to 10 12 to 13	GND	—	—	
14*3	GND	Output	—	

- Notes: 1. Input to or output from the user system.
2. The slash (/) means that the signal is active-low.
3. The emulator monitors the GND signal of the user system and detects whether the user system is connected or not.

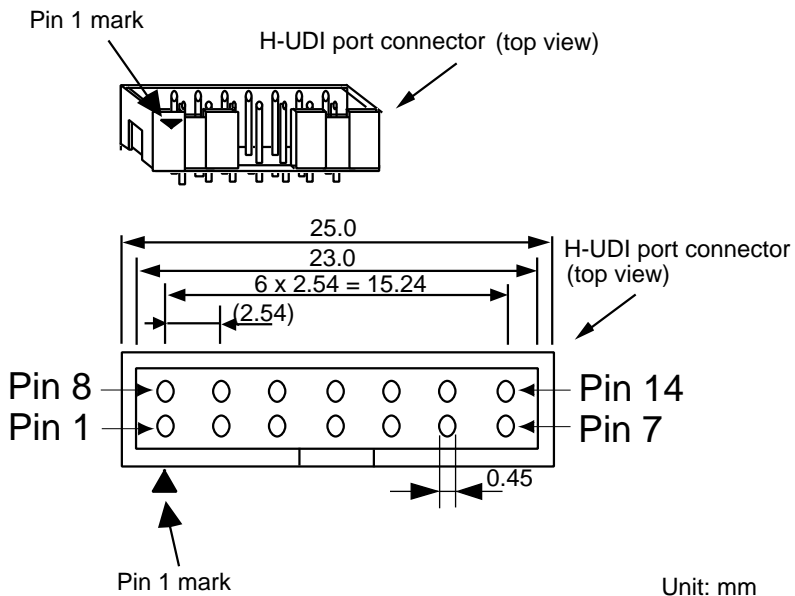

Figure 1.1 Pin Assignments of the H-UDI Port Connector

1.5 Recommended Circuit between the H-UDI Port Connector and the MPU

1.5.1 Recommended Circuit

Figure 1.2 shows a recommended circuit between the H-UDI port connector and the MPU.

- Notes:
1. Do not connect anything to the N.C. pin of the H-UDI port connector.
 2. The processing of the /ASEMD pin differs depending on whether the emulator is used or not. As the emulator does not control this pin, it must be controlled by a switch on the board.
 - (1) When the emulator is used: /ASEMD = low (ASE mode)
 - (2) When the emulator is not used: /ASEMD = high (normal mode)
 3. The reset signal in the user system is input to the /RES pin of the SH7618. Connect this signal to the H-UDI port connector as the output from the user system.
 4. When a network resistance is used for pull-up, it may be affected by a noise. Separate TCK from other resistances.
 5. The pattern between the H-UDI connector and the MPU must be as short as possible. Do not connect the signal lines to other components on the board.
 6. The resistance values shown in figure 1.2 are recommended.
 7. For the pin processing in cases where the emulator is not used, refer to the hardware manual of the related device.

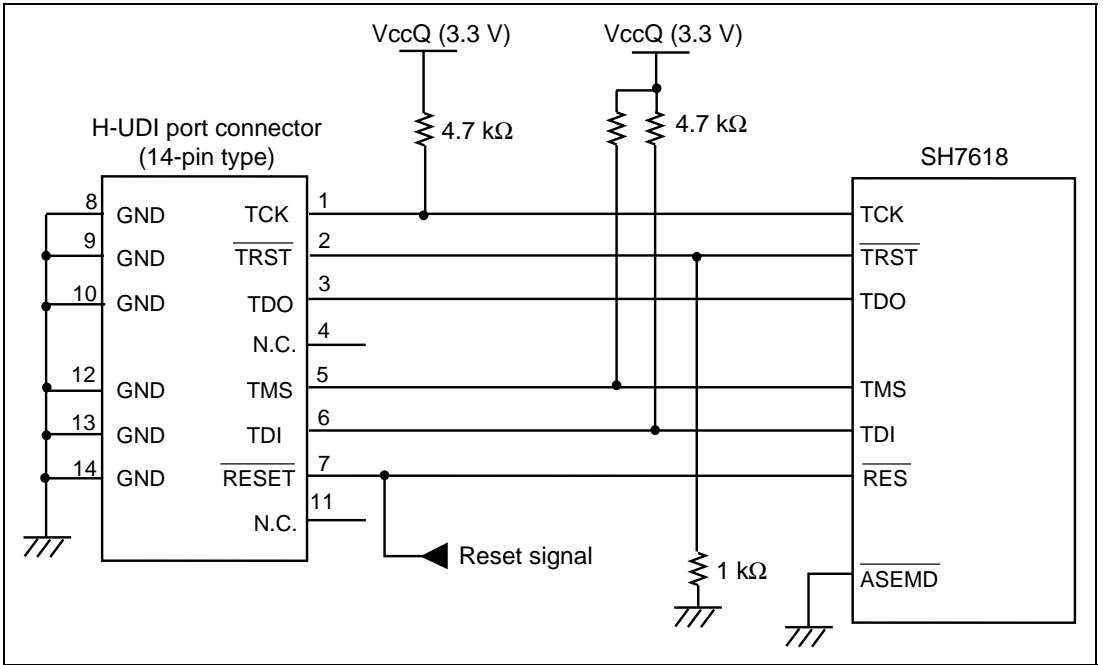

Figure 1.2 Recommended Circuit for Connection between the H-UDI Port Connector and MPU

Section 2 Specifications of the SH7618 E10A Emulator's Software

2.1 Differences between the SH7618 and the Emulator

- When the emulator system is initiated, it initializes the general registers and part of the control registers as shown in table 2.1. The initial values of the actual SH7618 registers are undefined.

Table 2.1 Register Initial Values at Emulator Power-On

Register	Emulator at Power-on
R0 to R14	H'00000000
R15 (SP)	SP in the vector address
PC	PC in the vector address
SR	H'000000F0
GBR	H'00000000
VBR	H'00000000
MACH	H'00000000
MACL	H'00000000
PR	H'00000000

- The emulator uses the H-UDI; do not access the H-UDI.
- Low-Power States (Sleep and Standby)

For low-power consumption, the SH7618 has sleep and standby states.

The sleep and standby states are switched using the SLEEP instruction. When the emulator is used, only the sleep state can be cleared with either the normal clearing function or with the [Stop] button, and a break will occur.

Note: The memory must not be accessed or modified in sleep state.

- Reset Signals

The SH7618 reset signals are only valid during emulation started with clicking the GO or STEP-type button. If these signals are input from the user system in command input wait state, they are not sent to the SH7618.

Note: Do not break the user program when the /RES and /WAIT signals are being low. A TIMEOUT error will occur. If the /WAIT signal is fixed to low during break, a TIMEOUT error will occur at memory access.

- Memory Access during User Program Execution

When a memory is accessed from the memory window, etc. during user program execution, the user program is resumed after it has stopped in the E10A emulator to access the memory. Therefore, realtime emulation cannot be performed.

The stopping time of the user program is as follows:

Environment:

Host computer: 650 MHz (Pentium® III)

SH7618: 50 MHz

JTAG clock: 3.75 MHz

When a one-byte memory is read from the command-line window, the stopping time will be about 20 ms.

- Memory Access during User Program Break

The emulator can download the program for the flash memory area. Other memory write operations are enabled for the RAM area. Therefore, an operation such as memory write or BREAKPOINT should be set only for the RAM area.

- Cache Operation during User Program Break

When cache is enabled, the emulator accesses the memory by the following methods:

- At memory write: Writes through the cache, then writes to the memory.
- At memory read: Does not change the cache write mode that has been set.

Therefore, when memory read or write is performed during user program break, the cache state will be changed.

- UBC

When [User] is specified in the [UBC mode] list box in the [Configuration] dialog box, the UBC can be used in the user program.

Do not use the UBC in the user program as it is used by the E10A emulator when [EML] is specified in the [UBC mode] list box in the [Configuration] dialog box.

- Loading Sessions

Information in [JTAG clock] of the [Configuration] dialog box cannot be recovered by loading sessions. Thus the TCK value will be as follows:

When HS7618KCI01H is used: TCK = 4.125 MHz

When HS7618KCM01H is used: TCK = 3.75 MHz

- [IO] Window

— Display and modification

Do not change values of the user break controller because it is used by the emulator.

For each watchdog timer register, there are two registers to be separately used for write and read operations.

Table 2.2 Watchdog Timer Register

Register Name	Usage	Register
WTCSR(W)	Write	Watchdog timer control/status register
WTCNT(W)	Write	Watchdog timer counter
WTCSR(R)	Read	Watchdog timer control/status register
WTCNT(R)	Read	Watchdog timer counter

- The watchdog timer operates only when the user program is executed. Do not change the value of the frequency change register in the [IO] window or [Memory] window.

- The internal I/O registers can be accessed from the [IO] window. After the I/O-register file is created, the MPU's specification may be changed. If each I/O register in the I/O-register definition file differs from addresses described in the hardware manual, change the I/O-register definition file according to the description in the hardware manual. The I/O-register definition file can be customized depending on its format. Note that, however, the E10A emulator does not support the bit-field function.

- Verify

In the [IO] window, the verify function of the input value is disabled.

- Illegal Instructions

If illegal instructions are executed by STEP-type commands, the emulator cannot go to the next program counter.

2.2 Specific Functions for the SH7618 E10A Emulator

The SH7618 E10A emulator does not support the following function:

- MMU-related functions (The SH7618 does not mount the MMU.)
 - VPMAP-related command
 - Virtual and Physical specification in the [Configuration] window
 - Virtual and Physical specification on the command-line function
 - Virtual and Physical specification in the [Breakpoint] window
 - LDTLB instruction execution break function
 - MEMORYAREA_SET command
- Profiler function
- Performance measurement function
- AUD trace function

2.2.1 Emulator Driver Selection

Table 2.3 shows drivers which are selected in the [E10A Driver Details] dialog box.

Table 2.3 Type Number and Driver

Type Number	Driver
HS7618KCM01H	E10A PC Card Driver 3
HS7618KCI01H	E10A PCI Card Driver 3

2.2.2 Break Condition Functions

In addition to BREAKPOINT functions, the emulator has Break Condition functions. Three types of conditions can be set under Break Condition 1, 2, 3. Table 2.4 lists these conditions of Break Condition.

Table 2.4 Types of Break Conditions

Break Condition Type	Description
Address bus condition (Address)	Breaks when the SH7618 address bus value or the program counter value matches the specified value.
Data bus condition (Data)	Breaks when the SH7618 data bus value matches the specified value. Byte, word, or longword can be specified as the access data size.
Bus state condition (Bus State)	<p>There are two bus state condition settings:</p> <p>Read/Write condition: Breaks when the SH7618 RD or RDWR signal level matches the specified condition.</p> <p>Bus state condition: Breaks when the operating state in an SH7618 bus cycle matches the specified condition.</p> <p>Types of buses that can be specified are listed below.</p> <ul style="list-style-type: none">• L-bus (CPU-ALL): Indicates an instruction fetch and data access, including a hit to the cache memory.• L-bus (CPU-Data): Indicates a data access by the CPU, including a hit to the cache memory.• I-bus (CPU.DMA): Indicates a CPU cycle when the cache memory is not hit, and a data access by the DMA.
Internal I/O break condition	Breaks when the SH7618 accesses the internal I/O.
Count	Breaks when the conditions set are satisfied the specified number of times.

Note: When U-RAM is accessed from the P0 space, the I-bus must be selected, and when accessed from the P2 space, the L-bus must be selected. When cache fill cycle is acquired, the I-bus must be selected.

Table 2.5 lists the combinations of conditions that can be set under Break Condition 1, 2, 3.

Table 2.5 Dialog Boxes for Setting Break Conditions

Dialog Box	Type				
	Address Bus Condition (Address)	Data Bus Condition (Data)	Bus State Condition (Bus Status)	Count Condition (Count)	Internal I/O Break
[Break Condition 1] dialog box	○	○	○	○	X
[Break Condition 2] dialog box	○	X	○	X	X
[Break Condition 3] dialog box	X	X	X	X	○

Note: ○: Can be set in the dialog box.
X: Cannot be set in the dialog box.

2.2.3 Trace Functions

The SH7618 E10A emulator supports the trace functions listed in table 2.6.

Table 2.6 Trace Functions

Function	Internal Trace
Branch trace	Supported (four branches)
Range memory access trace	Not supported
Software trace	Not supported

Internal Trace Function: This function is activated by selecting the [Internal trace] radio button in the [Trace type] group box of the [Trace mode] page. This function traces and displays the branch instructions. The branch source address and branch destination address for the four latest branch instructions are displayed.

Notes: 1. If an interrupt is generated at the program execution start or end, including a step execution, the emulator address may be acquired. In such a case, the following message will be displayed. Ignore this address because it is not a user program address.

*** EML ***

2. If a completion-type exception occurs during exception branch acquisition, the next address to the address in which an exception occurs is acquired.
3. Trace information cannot be acquired for the following branch instructions:
 - The BF and BT instructions whose displacement value is 0
 - Branch to H'A0000000 by reset
4. When [User] is specified in the [UBC mode] list box in the [Configuration] window, the internal trace is not acquired. In this case, exit the [Trace] window.
5. The SH7618 E10A emulator does not display the source code on the [Trace] window.

2.2.4 Note on Using the JTAG Clock (TCK)

Set the JTAG clock (TCK) frequency to less than the frequency of the SH7618 peripheral module clock (CKP).

2.2.5 Notes on Setting the [Breakpoint] Dialog Box

1. When an odd address is set, the next lowest even address is used.
2. A BREAKPOINT is accomplished by replacing instructions of the specified address. Accordingly, it can be set only to the internal RAM area. However, a BREAKPOINT cannot be set to the following addresses:
 - An area other than CS0 to CS6 and the internal RAM
 - An instruction in which Break Condition 2 is satisfied
 - A slot instruction of a delayed branch instruction
3. During step execution, BREAKPOINTS are disabled.
4. Conditions set at Break Condition 2 are disabled when an instruction to which a BREAKPOINT has been set is executed. Do not set a BREAKPOINT to an instruction in which Break Condition 2 is satisfied.
5. When execution resumes from the address where a BREAKPOINT is specified, single-step execution is performed at the address before execution resumes. Therefore, realtime operation cannot be performed.

6. When a BREAKPOINT is set to the slot instruction of a delayed branch instruction, the PC value becomes an illegal value. Accordingly, do not set a BREAKPOINT to the slot instruction of a delayed branch instruction.
7. When a BREAKPOINT is set to the cacheable area, the cache block containing the BREAKPOINT address is filled immediately before and after user program execution.
8. If an address of a BREAKPOINT cannot be correctly set in the ROM or flash memory area, a mark ● will be displayed in the [BP] area of the address on the [Editor] or [Disassembly] window by refreshing the [Memory] window, etc. after Go execution. However, no break will occur at this address. When the program halts with the break condition, the mark ● disappears.

2.2.6 Notes on Setting the [Break Condition] Dialog Box and BREAKCONDITION_SET Command

1. When [Go to cursor], [Step In], [Step Over], or [Step Out] is selected, the settings of Break Condition 2 are disabled.
2. Break Condition 2 is disabled when an instruction to which a BREAKPOINT has been set is executed. Accordingly, do not set a BREAKPOINT to an instruction which satisfies Break Condition 2.
3. When a Break Condition is satisfied, emulation may stop after two or more instructions have been executed.
4. If a PC break address condition is set to the slot instruction after a delayed branch instruction, user program execution cannot be terminated before the slot instruction execution; execution stops before the branch destination instruction.
5. Note that a break occurs with a break satisfaction condition by an instruction that has been cancelled due to the generation of an exception.
6. Use the sequential break or count break with the L-bus condition. If such break is used with the I-bus condition, it will not operate correctly.
7. A break will not occur with the execution counts specified on the execution of the multi-step instruction.

2.2.7 Notes on Setting the UBC_MODE Command

In the [Configuration] window, if [User] is set while the [UBC mode] list box has been set, the STEP-type commands that use Break Condition 2 for implementation cannot be used.

SuperH™ Family E10A Emulator
Additional Document for User's Manual
Specific Guide for the SH7618 E10A Emulator

Publication Date: Rev.1.00, December 16, 2003

Published by: Sales Strategic Planning Div.
Renesas Technology Corp.

Edited by: Technical Documentation & Information Department
Renesas Kodaira Semiconductor Co., Ltd.

SuperH™ Family E10A Emulator Additional Document for User's Manual



Renesas Electronics Corporation

1753, Shimonumabe, Nakahara-ku, Kawasaki-shi, Kanagawa 211-8668 Japan

REJ10B0077-0100H