

Evaluation Platform for RH850 and R-Car U5X

Common Main Board for RH850 and R-Car U5x

Y-COMMON-MB-T1-V1

Y-COMMON-MB-T1-V1-JP

The newest version of this document can be obtained from the following web location:

[Y-COMMON-MB-T1-V1](#)

All information contained in these materials, including products and product specifications, represents information on the product at the time of publication and is subject to change by Renesas Electronics Corp. without notice. Please review the latest information published by Renesas Electronics Corp. through various means, including the Renesas Electronics Corp. website (<https://www.renesas.com>)

Notice

1. Descriptions of circuits, software and other related information in this document are provided only to illustrate the operation of semiconductor products and application examples. You are fully responsible for the incorporation or any other use of the circuits, software, and information in the design of your product or system. Renesas Electronics disclaims any and all liability for any losses and damages incurred by you or third parties arising from the use of these circuits, software, or information.
 2. Renesas Electronics hereby expressly disclaims any warranties against and liability for infringement or any other claims involving patents, copyrights, or other intellectual property rights of third parties, by or arising from the use of Renesas Electronics products or technical information described in this document, including but not limited to, the product data, drawings, charts, programs, algorithms, and application examples.
 3. No license, express, implied or otherwise, is granted hereby under any patents, copyrights or other intellectual property rights of Renesas Electronics or others.
 4. You shall not alter, modify, copy, or reverse engineer any Renesas Electronics product, whether in whole or in part. Renesas Electronics disclaims any and all liability for any losses or damages incurred by you or third parties arising from such alteration, modification, copying or reverse engineering.
 5. Renesas Electronics products are classified according to the following two quality grades: "Standard" and "High Quality". The intended applications for each Renesas Electronics product depends on the product's quality grade, as indicated below.
"Standard": Computers; office equipment; communications equipment; test and measurement equipment; audio and visual equipment; home electronic appliances; machine tools; personal electronic equipment; industrial robots; etc.
"High Quality": Transportation equipment (automobiles, trains, ships, etc.); traffic control (traffic lights); large-scale communication equipment; key financial terminal systems; safety control equipment; etc.
Unless expressly designated as a high reliability product or a product for harsh environments in a Renesas Electronics data sheet or other Renesas Electronics document, Renesas Electronics products are not intended or authorized for use in products or systems that may pose a direct threat to human life or bodily injury (artificial life support devices or systems; surgical implantations; etc.), or may cause serious property damage (space system; undersea repeaters; nuclear power control systems; aircraft control systems; key plant systems; military equipment; etc.). Renesas Electronics disclaims any and all liability for any damages or losses incurred by you or any third parties arising from the use of any Renesas Electronics product that is inconsistent with any Renesas Electronics data sheet, user's manual or other Renesas Electronics document.
 6. When using Renesas Electronics products, refer to the latest product information (data sheets, user's manuals, application notes, "General Notes for Handling and Using Semiconductor Devices" in the reliability handbook, etc.), and ensure that usage conditions are within the ranges specified by Renesas Electronics with respect to maximum ratings, operating power supply voltage range, heat dissipation characteristics, installation, etc. Renesas Electronics disclaims any and all liability for any malfunctions, failure or accident arising out of the use of Renesas Electronics products outside of such specified ranges.
 7. Although Renesas Electronics endeavors to improve the quality and reliability of Renesas Electronics products, semiconductor products have specific characteristics, such as the occurrence of failure at a certain rate and malfunctions under certain use conditions. Unless designated as a high reliability product or a product for harsh environments in a Renesas Electronics data sheet or other Renesas Electronics document, Renesas Electronics products are not subject to radiation resistance design. You are responsible for implementing safety measures to guard against the possibility of bodily injury, injury or damage caused by fire, and/or danger to the public in the event of a failure or malfunction of Renesas Electronics products, such as safety design for hardware and software, including but not limited to redundancy, fire control and malfunction prevention, appropriate treatment for aging degradation or any other appropriate measures. Because the evaluation of microcomputer software alone is very difficult and impractical, you are responsible for evaluating the safety of the final products or systems manufactured by you.
 8. Please contact a Renesas Electronics sales office for details as to environmental matters such as the environmental compatibility of each Renesas Electronics product. You are responsible for carefully and sufficiently investigating applicable laws and regulations that regulate the inclusion or use of controlled substances, including without limitation, the EU RoHS Directive, and using Renesas Electronics products in compliance with all these applicable laws and regulations. Renesas Electronics disclaims any and all liability for damages or losses occurring as a result of your noncompliance with applicable laws and regulations.
 9. Renesas Electronics products and technologies shall not be used for or incorporated into any products or systems whose manufacture, use, or sale is prohibited under any applicable domestic or foreign laws or regulations. You shall comply with any applicable export control laws and regulations promulgated and administered by the governments of any countries asserting jurisdiction over the parties or transactions.
 10. It is the responsibility of the buyer or distributor of Renesas Electronics products, or any other party who distributes, disposes of, or otherwise sells or transfers the product to a third party, to notify such third party in advance of the contents and conditions set forth in this document.
 11. This document shall not be reprinted, reproduced or duplicated in any form, in whole or in part, without prior written consent of Renesas Electronics.
 12. Please contact a Renesas Electronics sales office if you have any questions regarding the information contained in this document or Renesas Electronics products.
- (Note 1) "Renesas Electronics" as used in this document means Renesas Electronics Corporation and also includes its directly or indirectly controlled subsidiaries.
- (Note 2) "Renesas Electronics product(s)" means any product developed or manufactured by or for Renesas Electronics.

General Precautions in the Handling of Microprocessing Unit and Microcontroller Unit Products

The following usage notes are applicable to all Microprocessing unit and Microcontroller unit products from Renesas. For detailed usage notes on the products covered by this document, refer to the relevant sections of the document as well as any technical updates that have been issued for the products.

1. Handling of Unused Pins

Handle unused pins in accordance with the directions given under Handling of Unused Pins in the manual.

- The input pins of CMOS products are generally in the high-impedance state. In operation with an unused pin in the open-circuit state, extra electromagnetic noise is induced in the vicinity of LSI, an associated shoot-through current flows internally, and malfunctions occur due to the false recognition of the pin state as an input signal become possible. Unused pins should be handled as described under Handling of Unused Pins in the manual.

2. Processing at Power-on

The state of the product is undefined at the moment when power is supplied.

- The states of internal circuits in the LSI are indeterminate and the states of register settings and pins are undefined at the moment when power is supplied.
In a finished product where the reset signal is applied to the external reset pin, the states of pins are not guaranteed from the moment when power is supplied until the reset process is completed.
In a similar way, the states of pins in a product that is reset by an on-chip power-on reset function are not guaranteed from the moment when power is supplied until the power reaches the level at which resetting has been specified.

3. Prohibition of Access to Reserved Addresses

Access to reserved addresses is prohibited.

- The reserved addresses are provided for the possible future expansion of functions. Do not access these addresses; the correct operation of LSI is not guaranteed if they are accessed.

4. Clock Signals

After applying a reset, only release the reset line after the operating clock signal has become stable. When switching the clock signal during program execution, wait until the target clock signal has stabilized.

- When the clock signal is generated with an external resonator (or from an external oscillator) during a reset, ensure that the reset line is only released after full stabilization of the clock signal. Moreover, when switching to a clock signal produced with an external resonator (or by an external oscillator) while program execution is in progress, wait until the target clock signal is stable.

5. Differences between Products

Before changing from one product to another, i.e. to a product with a different part number, confirm that the change will not lead to problems.

- The characteristics of Microprocessing unit or Microcontroller unit products in the same group but having a different part number may differ in terms of the internal memory capacity, layout pattern, and other factors, which can affect the ranges of electrical characteristics, such as characteristic values, operating margins, immunity to noise, and amount of radiated noise. When changing to a product with a different part number, implement a system-evaluation test for the given product.

Table of Contents

1.	Overview	8
1.1	Package Components	8
1.2	Applicable Piggyback Boards.....	9
1.3	Main Features	9
1.4	Main Board Versions	9
1.5	Extension Boards	12
1.6	Main Board Views	14
2.	Switches, Connectors, Jumpers, and LEDs	18
2.1	Switches Overview	22
2.2	Jumper Overview	22
2.3	LEDs Overview.....	22
2.4	Connectors Overview	24
3.	Power Supply	27
3.1	Board Power Connection	27
3.2	Board Power Switch, Reverse Voltage Connection Protection.....	28
3.3	Voltage Regulator Circuits.....	29
3.4	Peripheral Supply Voltage VDDIOF	30
3.5	Voltage Level LEDs.....	33
4.	Main Board Configuration.....	34
4.1	General description	34
4.2	Main Board Configurator Software	38
4.2.1	Main Board Connection.....	38
4.2.2	General Operation.....	38
4.2.3	Main Board Firmware Update	40
5.	Peripheral Circuits	41
5.1	Piggyback Board	41
5.1.1	Piggyback Board Connectors.....	41
5.2	LIN Interfaces	47
5.2.1	LIN Circuit Diagram.....	47
5.2.2	LIN Interface Connectors	49
5.2.3	LIN0 / UART0 selection.....	50
5.3	CAN Interfaces	50
5.3.1	CAN Circuit Diagram.....	50
5.3.2	CAN Interface Connectors	52
5.4	CAN XL Modules.....	54
5.4.1	CAN XL Board Y-COMMON-CANXL-xxxx	55
5.5	FlexRay Interfaces	56

5.5.1	Circuit Diagram.....	56
5.5.2	FlexRay Connectors.....	60
5.6	Ethernet Modules	61
5.6.1	Ethernet Modules Supporting MII/SGMII	61
5.6.1.1	Circuit Diagram.....	61
5.6.1.2	Pin Assignments of MII/SGMII Ethernet Connectors	63
5.6.1.3	Renesas Ethernet Board Y-COMMON-100BASE-TX-LAN8700	65
5.6.1.4	Renesas Ethernet Board Y-COMMON-1000BASE-T1-88Q2112.....	66
5.6.2	Ethernet Modules Supporting T1S.....	67
5.6.2.1	Ethernet Board Y-COMMON-10BASE-T1S-xxxx	68
5.7	SENT (Single Edge Nibble Transmission) Interfaces	71
5.7.1	SENT Interface Connectors	73
5.8	UART Interfaces	73
5.8.1	Circuit Diagram.....	74
5.8.2	UART Connector	76
5.9	Connection Cable for Various Interfaces	77
5.10	Serial Flash Memory	79
5.11	MicroSD Card Interface.....	80
5.12	Display.....	81
5.12.1	TFT Display	81
5.12.1.1	Circuit Diagram.....	81
5.12.1.2	Usage Information.....	81
5.12.1.3	Touch Display Connectors	82
5.12.2	OLED Graphic Display	83
5.13	Pmod™ Interfaces.....	84
5.14	RGB Illuminated Rotary Encoder	87
5.15	LED CSI Driver for LED Ring Indicator	88
5.16	Motor Control Circuit	89
5.16.1	Motor Control Extension Board Y-COMMON-BLDC-MOTOR-DRV.....	91
5.17	Resolver Circuit	92
5.18	Interrupt Push Buttons.....	94
5.19	A/D Measurements.....	95
5.20	Signal LEDs.....	96
5.21	I2S Interface	97
5.22	IIC Level Shifter	98
6.	Precautions	99
6.1	Resolver Circuit	99
7.	Mechanical Dimensions.....	100
8.	Schematics.....	104
8.1	Board Version D019712_06_V01	105

8.1.1	Page 1: Table of Contents	105
8.1.2	Page 2: Power Supply.....	106
8.1.3	Page 3: Voltage-/Signal LEDs / IIC0 / Board Configurator	107
8.1.4	Page 4: LIN / SENT Interfaces.....	108
8.1.5	Page 5: UART Interfaces	109
8.1.6	Page 6: CAN (XL) Interfaces.....	110
8.1.7	Page 7: FlexRay Interfaces.....	111
8.1.8	Page 8: Ethernet / SD Card / SFMA / I2S.....	112
8.1.9	Page 9: Encoder / LED CSI-Driver	113
8.1.10	Page 10: Display / Interrupt / A/D Measurement	114
8.1.11	Page 11: Resolver.....	115
8.1.12	Page 12: Motor.....	116
8.1.13	Page 13: Pmod™ Interfaces	117
8.1.14	Page 14: Piggyback Board Connectors / Multiplexer	118
8.1.15	Page 15: LIN Transceiver X4	119
8.1.16	Page 16: LIN Transceiver	120
8.1.17	Page 17: CAN Transceiver X4	121
8.1.18	Page 18: CAN Transceiver	122
8.2	Board Version D019712_06_V02	123
8.2.1	Page 1: Table of Contents	123
8.2.2	Page 2: Power Supply.....	124
8.2.3	Page 3: Voltage-/Signal LEDs / IIC0 / Board Configurator	125
8.2.4	Page 4: LIN / SENT Interfaces.....	126
8.2.5	Page 5: UART Interfaces	127
8.2.6	Page 6: CAN (XL) Interfaces.....	128
8.2.7	Page 7: FlexRay Interfaces.....	129
8.2.8	Page 8: Ethernet / SD Card / SFMA / I2S.....	130
8.2.9	Page 9: Encoder / LED CSI Driver.....	131
8.2.10	Page 10: Display / Interrupt / A/D Measurement	132
8.2.11	Page 11: Resolver.....	133
8.2.12	Page 12: Motor.....	134
8.2.13	Page 13: Pmod™ Interfaces	135
8.2.14	Page 14: Piggyback Connectors / Multiplexer	136
8.2.15	Page 15: LIN Transceiver X4	137
8.2.16	Page 16: LIN Transceiver	138
8.2.17	Page 17: CAN Transceiver X4	139
8.2.18	Page 18: CAN Transceiver	140
8.3	Board Version D019712_06_V03	141
8.3.1	Page 1: Table of Contents	141
8.3.2	Page 2: Power Supply.....	142
8.3.3	Page 3: Voltage-/Signal LEDs / IIC0 / Board Configurator	143
8.3.4	Page 4: LIN / SENT Interfaces.....	144

8.3.5	Page 5: UART Interfaces	145
8.3.6	Page 6: CAN (XL) Interfaces.....	146
8.3.7	Page 7: FlexRay Interfaces.....	147
8.3.8	Page 8: Ethernet / SD Card / SFMA / I2S.....	148
8.3.9	Page 9: Encoder / LED CSI Driver.....	149
8.3.10	Page 10: Display / Interrupt / A/D Measurement	150
8.3.11	Page 11: Resolver.....	151
8.3.12	Page 12: Motor.....	152
8.3.13	Page 13: Pmod™ Interfaces	153
8.3.14	Page 14: Piggyback Connectors / Multiplexer	154
8.3.15	Page 15: LIN Transceiver X4	155
8.3.16	Page 16: LIN Transceiver	156
8.3.17	Page 17: CAN Transceiver X4	157
8.3.18	Page 18: CAN Transceiver	158
8.4	Board Version D019712_06_V04	159
8.4.1	Page 1: Table of Contents	159
8.4.2	Page 2: Power Supply.....	160
8.4.3	Page 3: Voltage-/Signal LEDs / IIC0 / Board Configurator	161
8.4.4	Page 4: LIN / SENT Interfaces.....	162
8.4.5	Page 5: UART Interfaces	163
8.4.6	Page 6: CAN (XL) Interfaces.....	164
8.4.7	Page 7: FlexRay Interfaces.....	165
8.4.8	Page 8: Ethernet / SD Card / SFMA / I2S.....	166
8.4.9	Page 9: Encoder / LED CSI Driver.....	167
8.4.10	Page 10: Display / Interrupt / A/D Measurement	168
8.4.11	Page 11: Resolver.....	169
8.4.12	Page 12: Motor.....	170
8.4.13	Page 13: Pmod™ Interfaces	171
8.4.14	Page 14: Piggyback Connectors / Multiplexer	172
8.4.15	Page 15: LIN Transceiver X4	173
8.4.16	Page 16: LIN Transceiver	174
8.4.17	Page 17: CAN Transceiver X4	175
8.4.18	Page 18: CAN Transceiver	176

1. Overview

The Common Main Board for RH850 and R-Car U5x serves as a simple and easy to use platform for evaluating the features and performance of Renesas Electronics' 32-bit RH850 and R-Car/U5x microcontrollers. This main board must be used in conjunction with a piggyback board (e.g. Y-RH850-U2A-516PIN-PB-T1-V1), that carries the target microcontroller.

Actually we have 2 different versions of the main board, Y-COMMON-MB-T1-V1 and Y-COMMON-MB-T1-V1-JP. The only difference is whether the power supply is included in the delivery or not (refer to *Table 1.1 Package Components for the Y-COMMON-MB-T1-V1*). Thus, we only use the name Y-COMMON-MB-T1-V1 throughout the manual.

Notes

1. The document describes the functionality of the main board and guides the user through its operation. For details regarding the operation of the microcontroller, please refer to the device's Hardware User's Manual.
2. In this document active low signals are marked by an appended 'Z' to the pin or signal name. E.g. the reset pin is named RESETZ.
3. In this document following abbreviations are used:
 - H level, L level: high or low signal level of a digital signal, the absolute voltage value depends on the signal

1.1 Package Components

The Y-COMMON-MB-T1-V1 product package consists of the following items. After you have unpacked the box, check if your Y-COMMON-MB-T1-V1 package contains all of these items. Table 1.1 Package Components for the Y-COMMON-MB-T1-V1 shows all components in the Y-COMMON-MB-T1-V1 package.

Table 1.1 Package Components for the Y-COMMON-MB-T1-V1

Item	Description	Quantity
D019712#01T	Main board for RH850 / R-Car	1
236-000016-05	Power supply unit, 12V/2A, incl. 4 international AC plugs.	1, not included in Y-COMMON-MB-T1-V1-JP
228-000078-01	USB Cable, Type A to Type-C	1 (board version D019712_06_V02 and later)
228-000058-01	Red connection cables	8
228-000059-01	Black connection cables	8
230-000109-01	Parallel Cable [1x DIL connector 10-pin - 1x D-SUB connector 9-pin]	8
230-000110-01	Sub-D male to male gender changer, 9-pin	8
230-000003-01	Jumper (2-way, 0.1")	1

Note

Please keep the Y-COMMON-MB-T1-V1 packaging at hand for later reuse in sending the product for repair or for other purposes. Always use the original packaging when transporting the Y-COMMON-MB-T1-V1. If packing of your product is not complete, it may be damaged during transportation.

1.2 Applicable Piggyback Boards

For a list of applicable piggyback boards please refer to the "Related products" list via the following link:

[Y-COMMON-MB-T1-V1](#)

1.3 Main Features

- Single board power supply (12V) with on-board voltage regulators
- High density connectors for piggyback boards
- Board set-up via PC GUI software
- 16 CAN interfaces supporting CAN FD
- 24 LIN interfaces
- Two FlexRay interfaces
- Two SENT interfaces
- Three connectors for Ethernet modules supporting MII, SGMII, T1S
- Two connectors for two CAN XL interfaces each
- Two graphic display connectors
- Two connectors for motor control signal outputs, one with resolver input circuit
- Two Pmod™ connectors providing serial interfaces in various standards
- Two UART interfaces, 1 with connection to USB PHY
- One SD-card interface
- Four general purpose signal LEDs
- LED ring indicator with 16 LEDs
- Rotary encoder with RGB illuminated shaft
- Two interrupt push buttons
- Two potentiometers for analog signal input
- Serial flash memory (not mounted)
- Operating temperature from 0°C to +40°C

1.4 Main Board Versions

The following versions of the main board are available:

Table 1.2 Y-COMMON-MB-T1-V1 board versions

Board Version	Schematic Version
D019712_06_V01	D019712_04_V0105
D019712_06_V02	D019712_04_V0202
D019712_06_V03	D019712_04_V0302
D019712_06_V04	D019712_04_V0400

Table 1.3 on the next pages lists all modifications that have been implemented in different board revisions.

Table 1.3 Differences between board versions V01, V02, V03 and V04

Item	Modified Function	Detailed Description of Changes	D019712_06_V01	D019712_06_V02	D019712_06_V03	D019712_06_V04
1	IIC0 level shift circuit	Modified level shift circuit.	Uses transistors SI1902DL.	Uses transceiver IC NXS0102.		
2	Reverse voltage protection circuit	Modified circuit on FLT# and EN ports of protection IC.	Original circuit.	Added some resistors, diodes, and a transistor.		
3	LIN and CAN transceivers (each channel), FlexRay interfaces (each channel), SENT interfaces (each channel), UART interfaces (each channel), SD card interface, SFMA, LED ring indicator, Encoder, A/D measurement circuit, IIC0 level shifter	Added LEDs to peripheral circuits to indicate module has been activated	No activation LEDs.	Activation LEDs added.		
4	VIO selection circuit on FlexRay0 interface	Changed VIO control circuit.	Capacitor C245 is connected to GND.	Capacitor C245 is connected to PMOS output.		
5	VIO selection circuit on FlexRay1 interface	Changed VIO control circuit.	Capacitor C246 is connected to GND.	Capacitor C246 is connected to PMOS output.		
6	VIO selection circuit on SFMA	Changed VIO control circuit.	Capacitor C247 is connected to GND.	Capacitor C247 is connected to PMOS output.		
7	USB connector CN6	Changed USB connector.	Connector Micro-AB type for USB 2.0.	Connector is Type-C for USB-C.		
8	UART0 circuit	Connected open input ports T2IN_TTL and R2_TTL on IC14.	Input ports T2IN_TTL and R2_TTL were left open.	Input ports T2IN_TTL and R2_TTL clamped to defined signal levels.		
9	RL78 board configurator	Modified RESET_TR circuit.	Transistor is only controlled by RL78 port.	Added resistor to transistor to give it a defined state when RL78 port output is undefined.		
10	Display 1 connector	Modified signal lines from display to RL78.	Control ports for display are only connected to RL78	Added pull-down resistors MR26 to communication signals.		
11	CSI LED	Modified signals CSI0_PMOD_EN# and CSI0LE.	CSI0_PMOD_EN# and CSI0LE are only connected to RL78 ports.	Added pull-up resistor R316 to CSI0_PMOD_EN# signal and pull-down resistor R317 to CSI0LE signal.		
12	Ethernet connectors	Connection for ETH0RESET and ETH1RESET modified.	ETH0RESET and ETH1RESET only connected to piggyback board connector.	Added pull-down resistors R313 (ETH0RESET) and R314 (ETH1RESET). On delivery the pulldown resistors are not assembled.		
13	SD card interface	Modified SD card enable circuit.	SD_EN# signal is only connected to RL78 port.	Added pull-up resistor R315 to SD_EN# signal.		
14	Resolver circuit	Improve output waveform of the resolver circuit.	Has to be fixed manually.		Fixed in hardware.	
15	LED17 and LED18 at SENT connectors CN11 and CN101	LEDs for SENT activity.	No LEDs included.	LED17 and LED18 included at SENT ports, but they don't work.	LED17 and LED18 work correctly.	

Table 1.3 Differences between board versions V01, V02, V03 and V04 (cont'd)

Item	Modified Function	Detailed Description of Changes	D019712_06_V01	D019712_06_V02	D019712_06_V03	D019712_06_V04
16	LED29, LED30 and LED31 for Motor 0 activity	Changed implementation	LED29, LED30 and LED31 are always active when the motor is being used.		LED29, LED30 and LED31 can be switched on and off in the board configurator software.	
17	INT3 interrupt input	Changed implementation	The interrupt signals from the encoder switch IC22 and from an external Ethernet module connected to Ethernet 1 connector CN25 are connected together.		INT3 source can be selected in the board configurator as Ethernet 1 or encoder switch interrupt.	
18	Control circuit for VBAT_FLX0 power supply	Added low pass filter in control of output transistor TR29.	Output transistor directly controlled by switching transistor TR28.			Added low pass filter with resistor R101 and capacitor C202 at base of output transistor TR29.
19	Control circuit for VBAT_FLX1 power supply	Added low pass filter in control of output transistor TR35.	Output transistor directly controlled by switching transistor TR34.			Added low pass filter with resistor R102 and capacitor C203 at base of output transistor TR35.
20	Board configurator RL78	Possibility to reset RL78 by the USB interface IC	No direct possibility to reset RL78 from the USB interface IC.		Added footprint for IC56 (NXS0102) to use RTS signal of the UART interface IC as reset signal for RL78.	No direct possibility to reset RL78 from the USB interface IC.

1.5 Extension Boards

Renesas offers some extension boards for this main board to provide additional functionality.

Table 1.4 Extension board overview





Order Code	Description	Board Picture
Y-RH850-TFT-EXT-BRD	TFT display / 2.8" TFT touch shield with capacitive touch	
Y-RH850-SENT-EXT-BRD-V2	SENT extension board with IDT ZSSC416x sensor device	
Y-COMMON-100BASE-TX-LAN8700 (former Y-RH850-100BASE-TX-LAN8700)	Ethernet extension board with LAN8700 100BASE-TX transceiver	
Y-COMMON-1000BASE-T1-88Q2112 (former Y-RH850-1000BASE-T1-88Q2112)	Ethernet extension board with Marvell 88Q2112 1000BASE-T1 transceiver	
Y-COMMON-10BASE-T1S-NN Y-COMMON-10BASE-T1S-TJA1410A	Universal Ethernet extension board for 10BASE-T1S transceivers of various manufacturers. Ethernet extension board equipped with NXP TJA1410A 10BASE-T1S transceiver.	
Y-COMMON-CANXL-NN Y-COMMON-CANXL-TCAN6062V	Universal CAN extension board for CAN XL transceivers of various manufacturers. CAN extension board equipped with TI TCAN6062V CAN XL transceivers.	

Table 1.4 Extension board overview (cont'd)

Order Code	Description	Board Picture
Y-COMMON-BLDC-MOTOR-DRV	Motor control board for brushless DC motor connection	

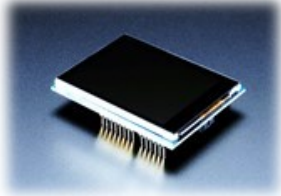
1.6 Main Board Views

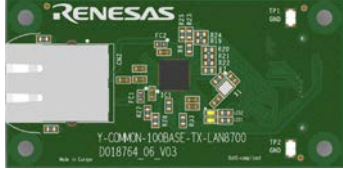
The following figures provide the top and bottom views of the main board.

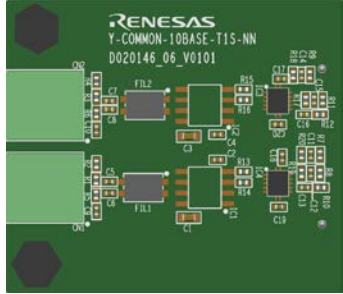
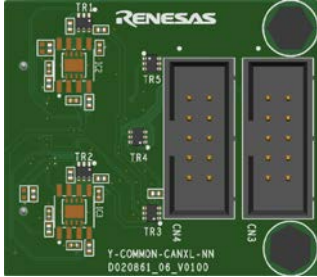
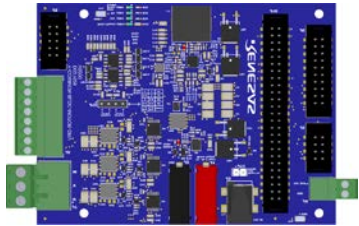
In the beginning this board was designed as main board for RH850 piggyback boards. Thus, the product name was “Y-RH850-X2X-MB-T1-V2”.

When the usage of the board was extended to also support R-CAR/U5x piggyback boards, the product name changed to “Y-COMMON-MB-T1-V1”.



Figure 1.1 Main board top view of board version D019712_06_V01

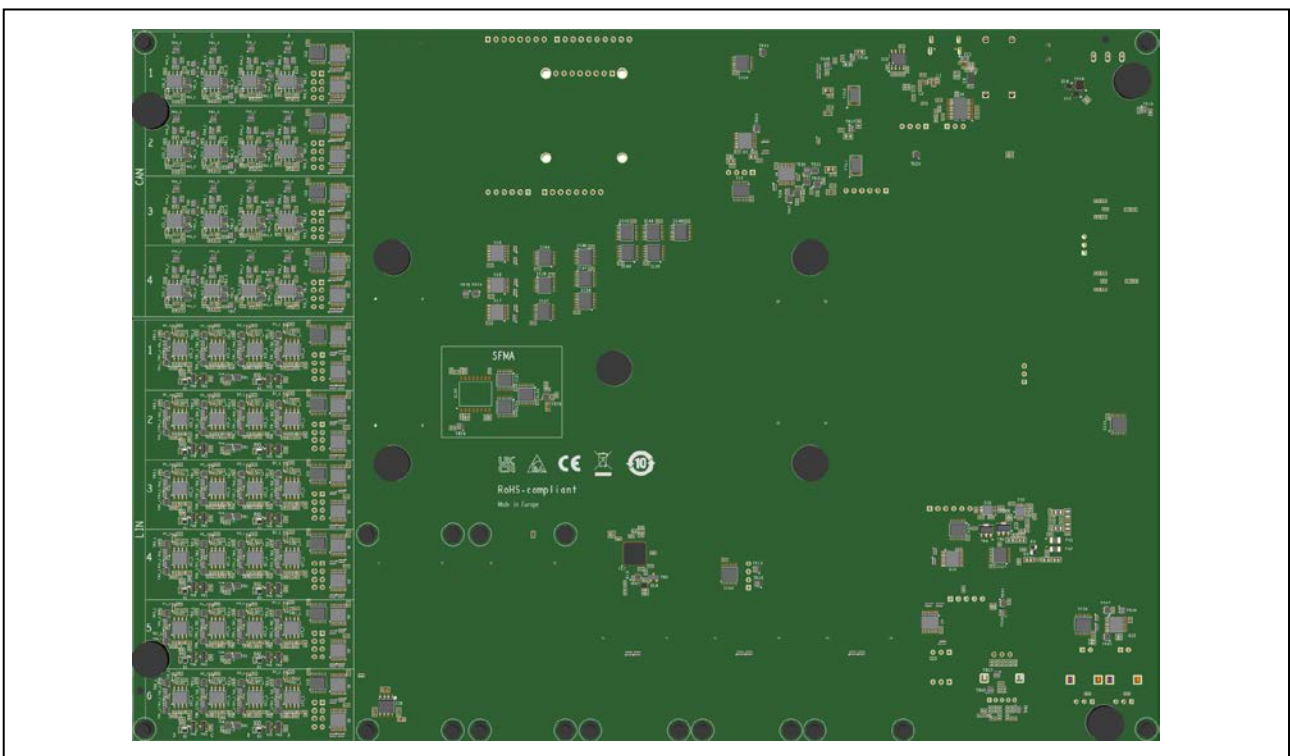

Figure 1.2 Main board bottom view of board version D019712_06_V01

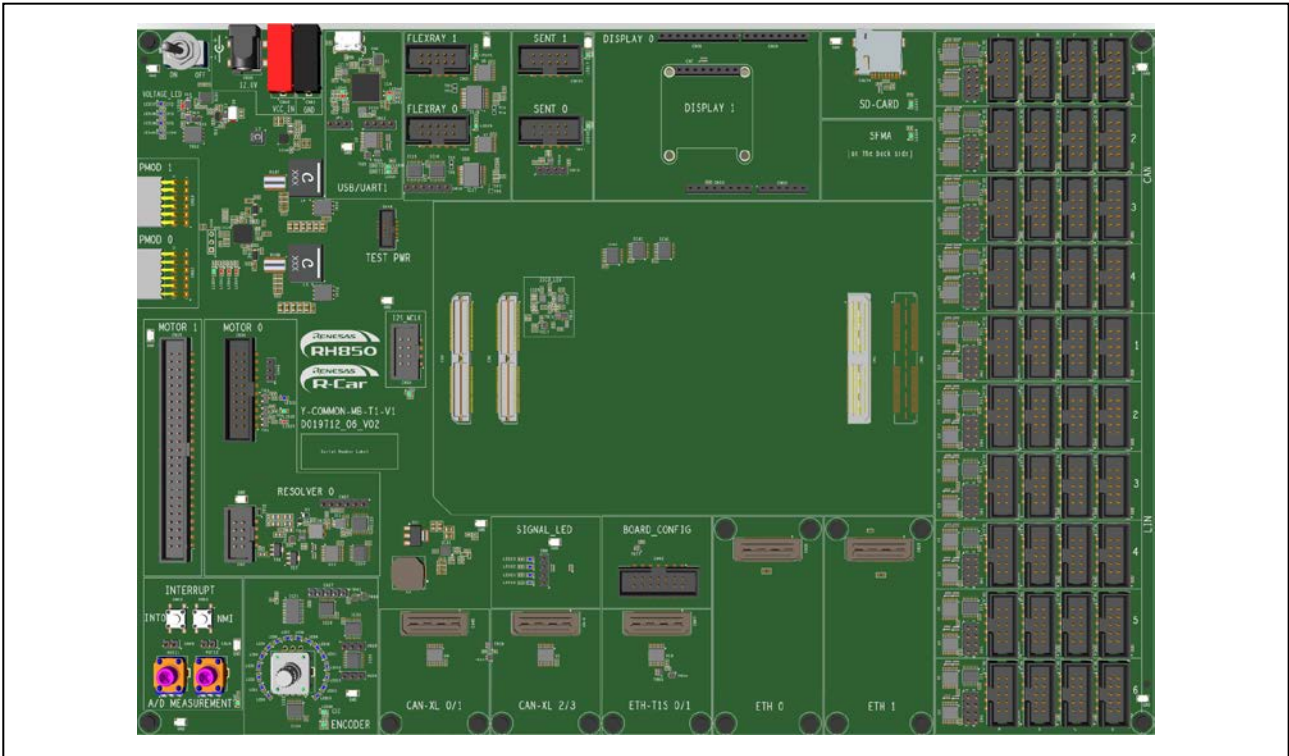

Figure 1.3 Main board bottom view of board version D019712_06_V02

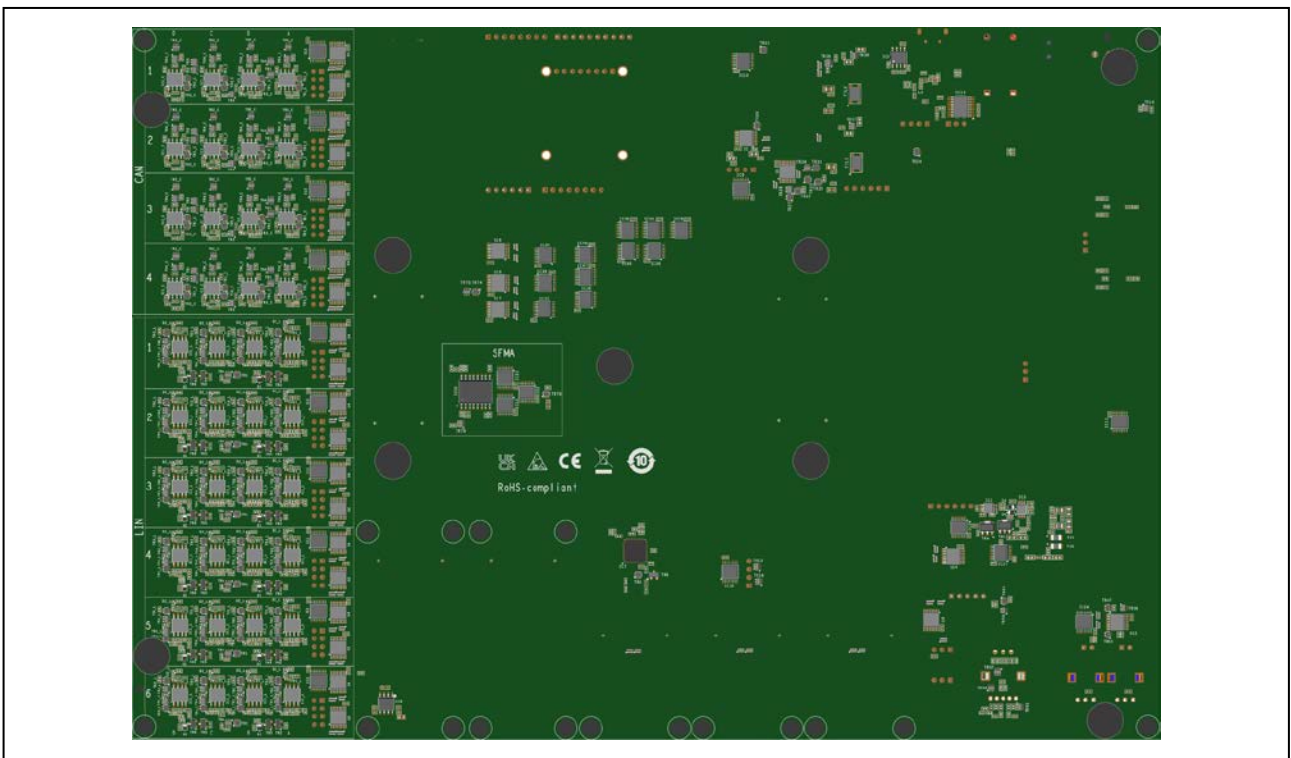

Figure 1.4 Main board top view of board version D019712_06_V02

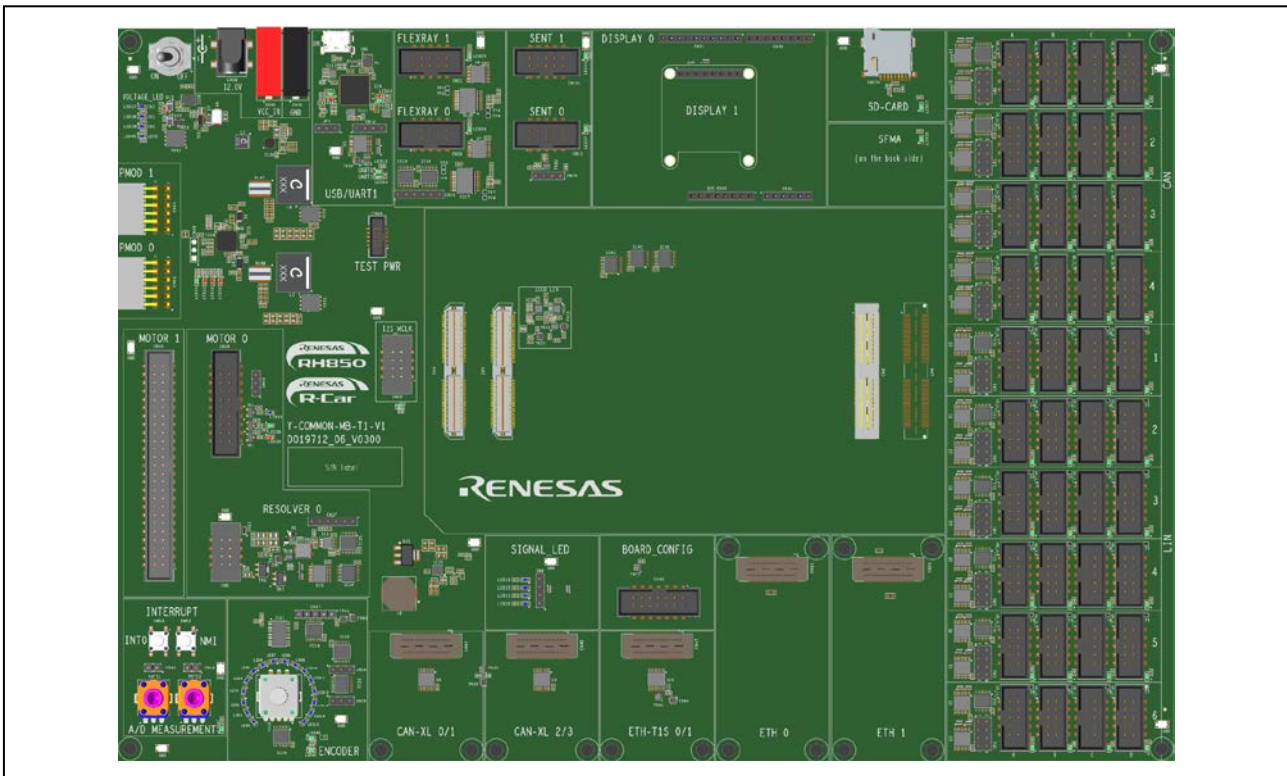

Figure 1.5 Main board top view of board version D019712_06_V03

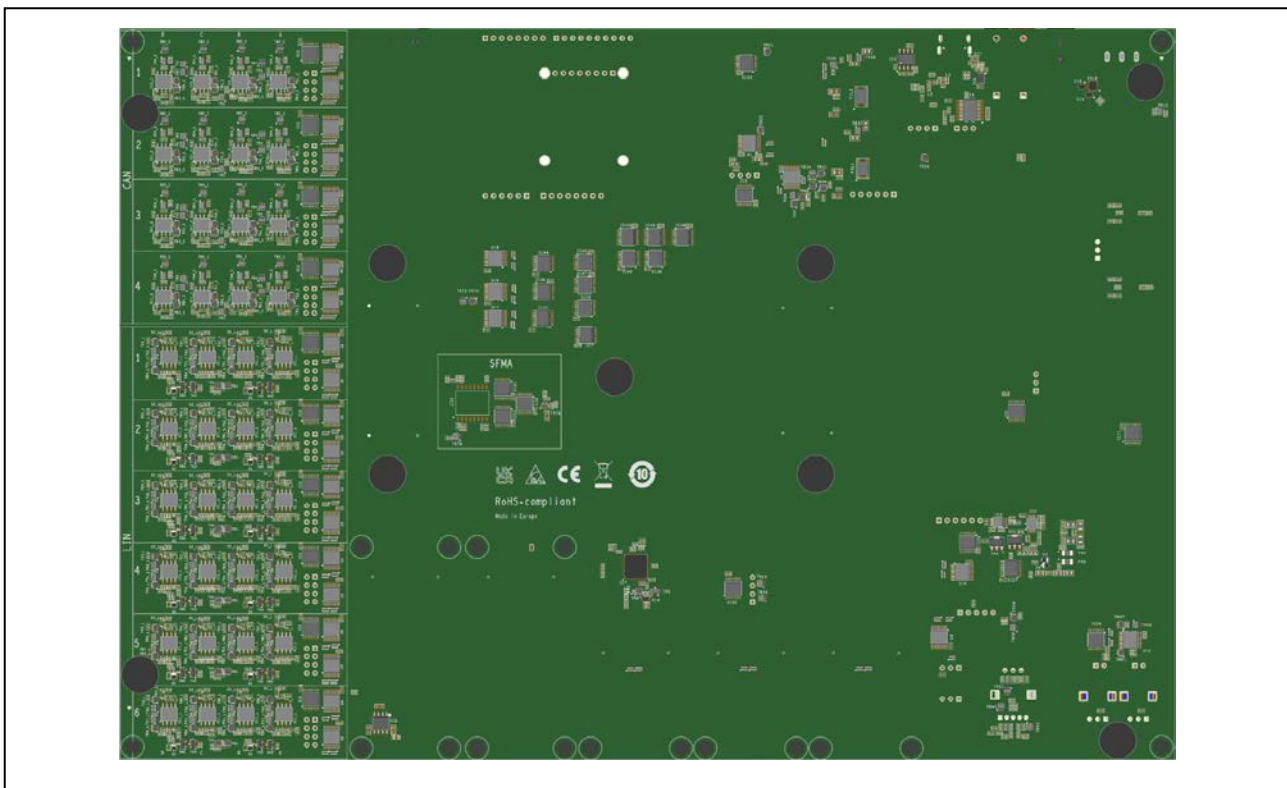

Figure 1.6 Main board bottom view of board version D019712_06_V03

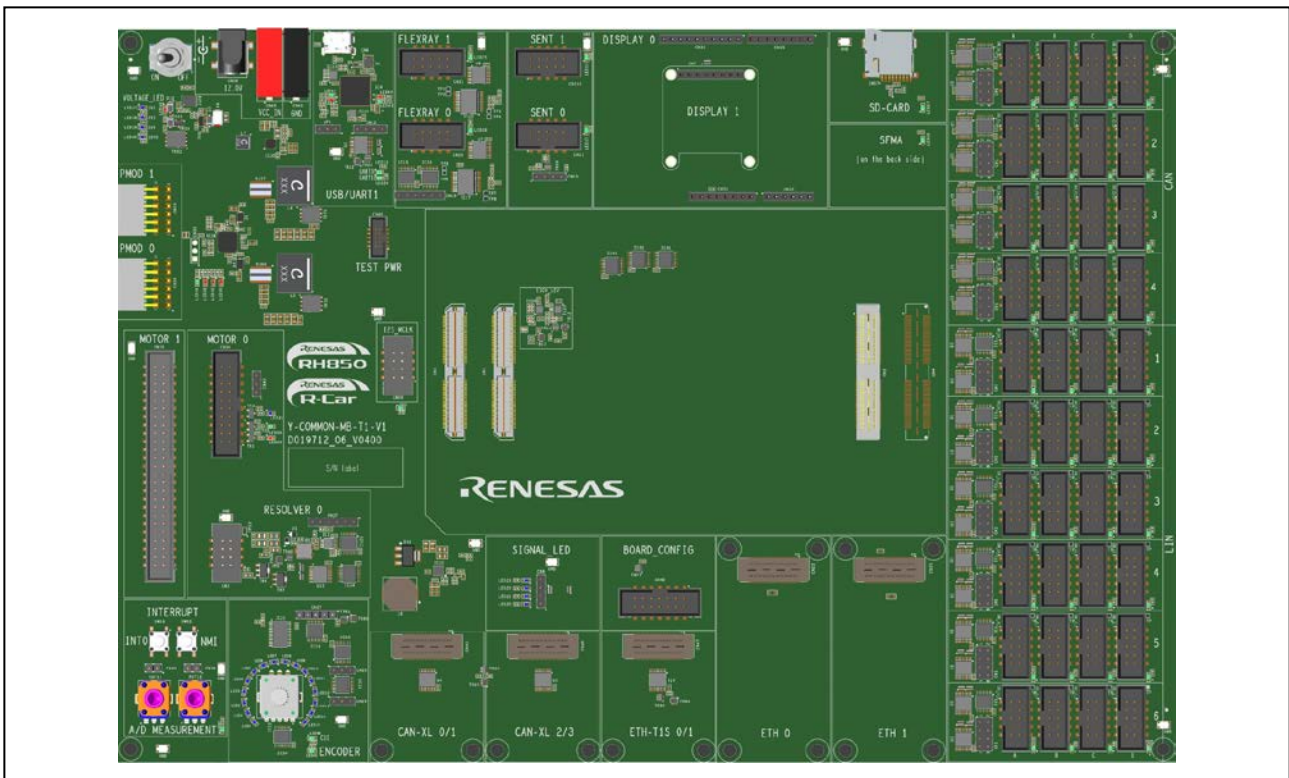

Figure 1.7 Main board top view of board version D019712_06_V04

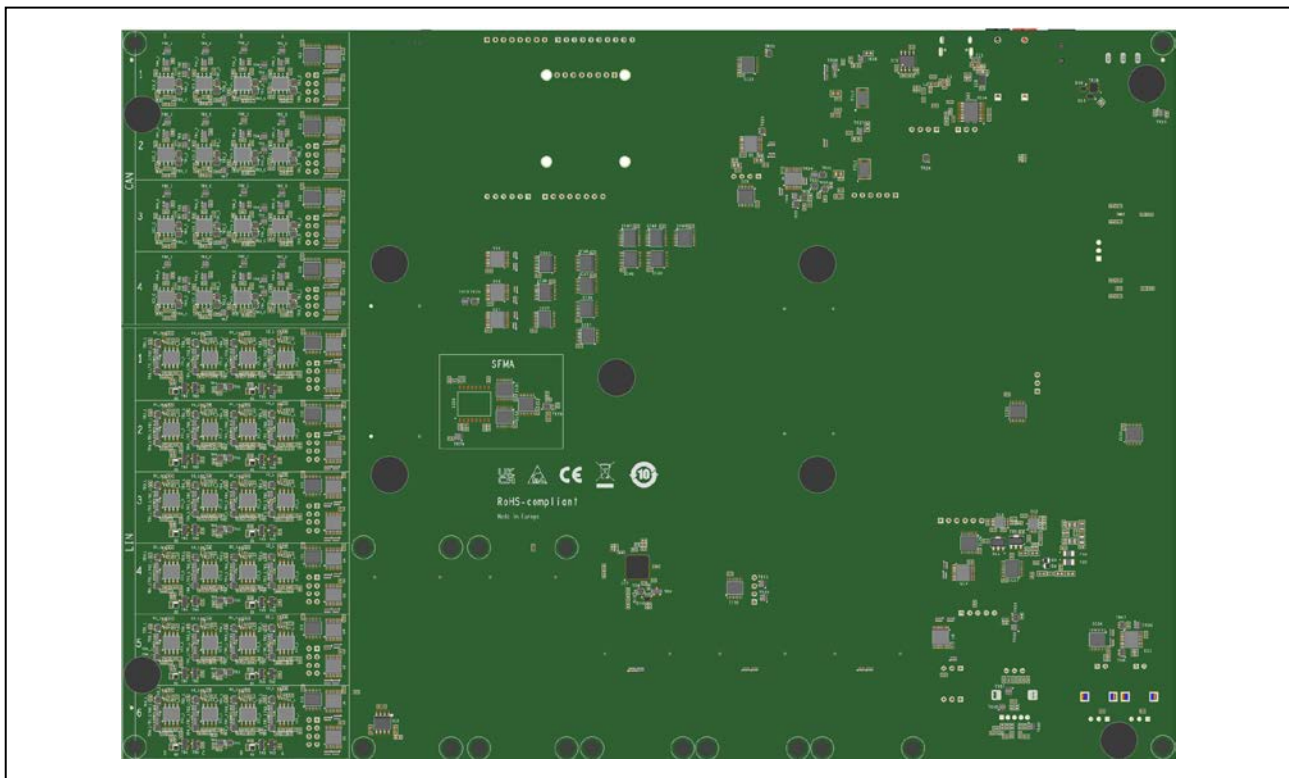

Figure 1.8 Main board bottom view of board version D019712_06_V04

2. Switches, Connectors, Jumpers, and LEDs

This section provides complete lists of all switches, connectors, jumpers, and LEDs.

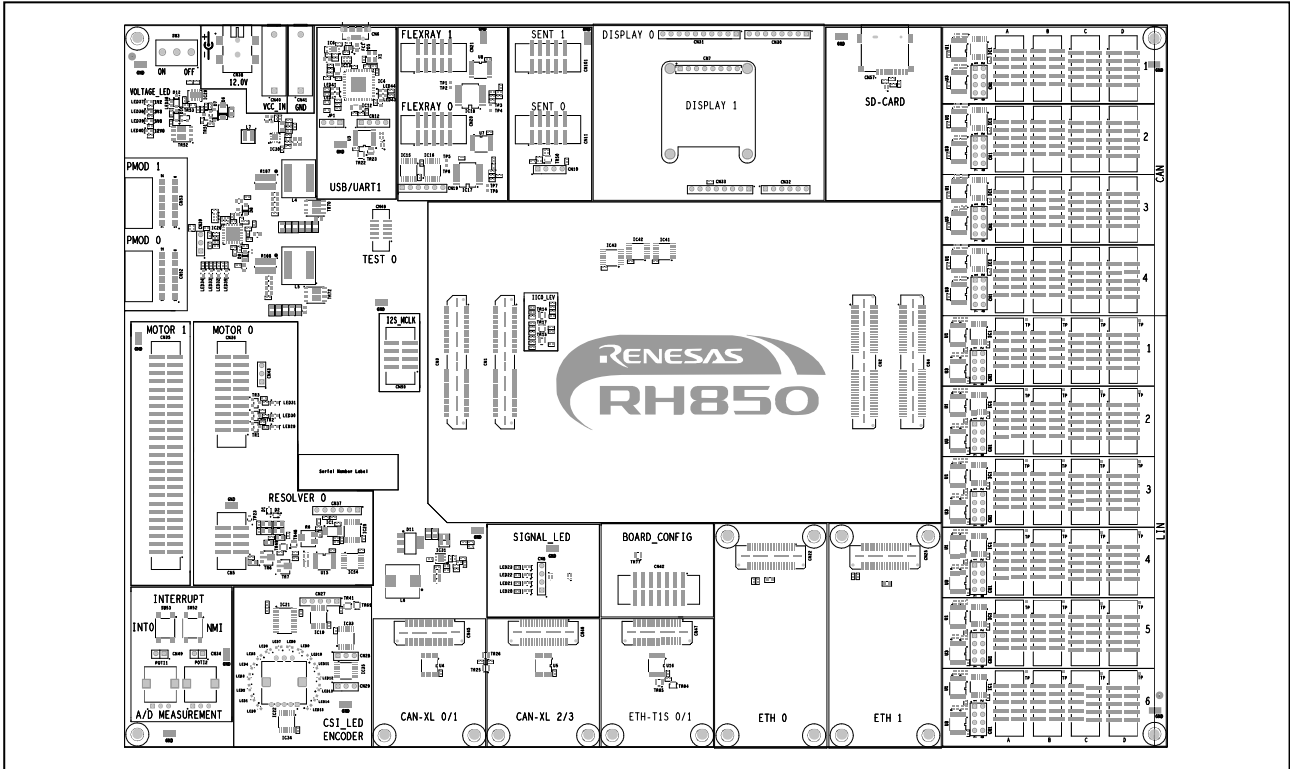

Figure 2.2 Placement of switches, connectors and LEDs on top side of board version D019712_06_V01

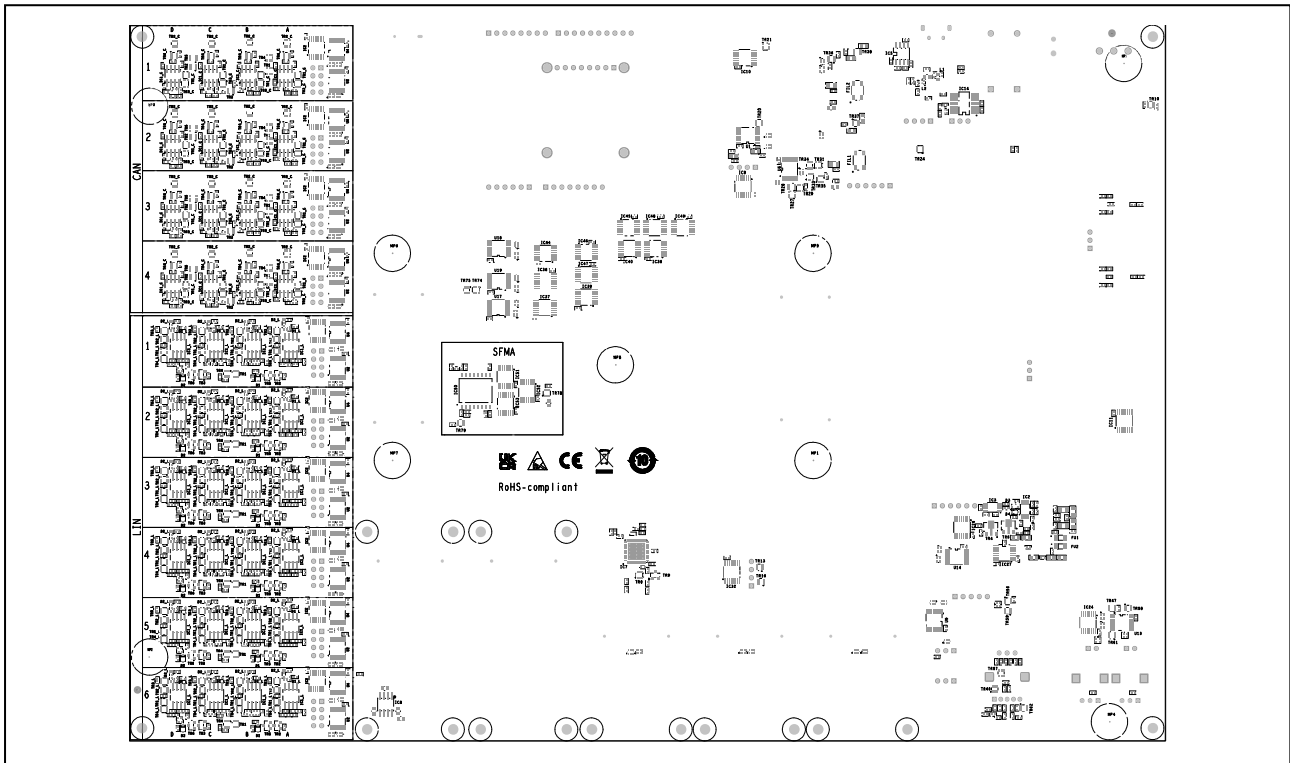

Figure 2.1 Placement of switches, connectors and LEDs on bottom side of board version D019712_06_V01

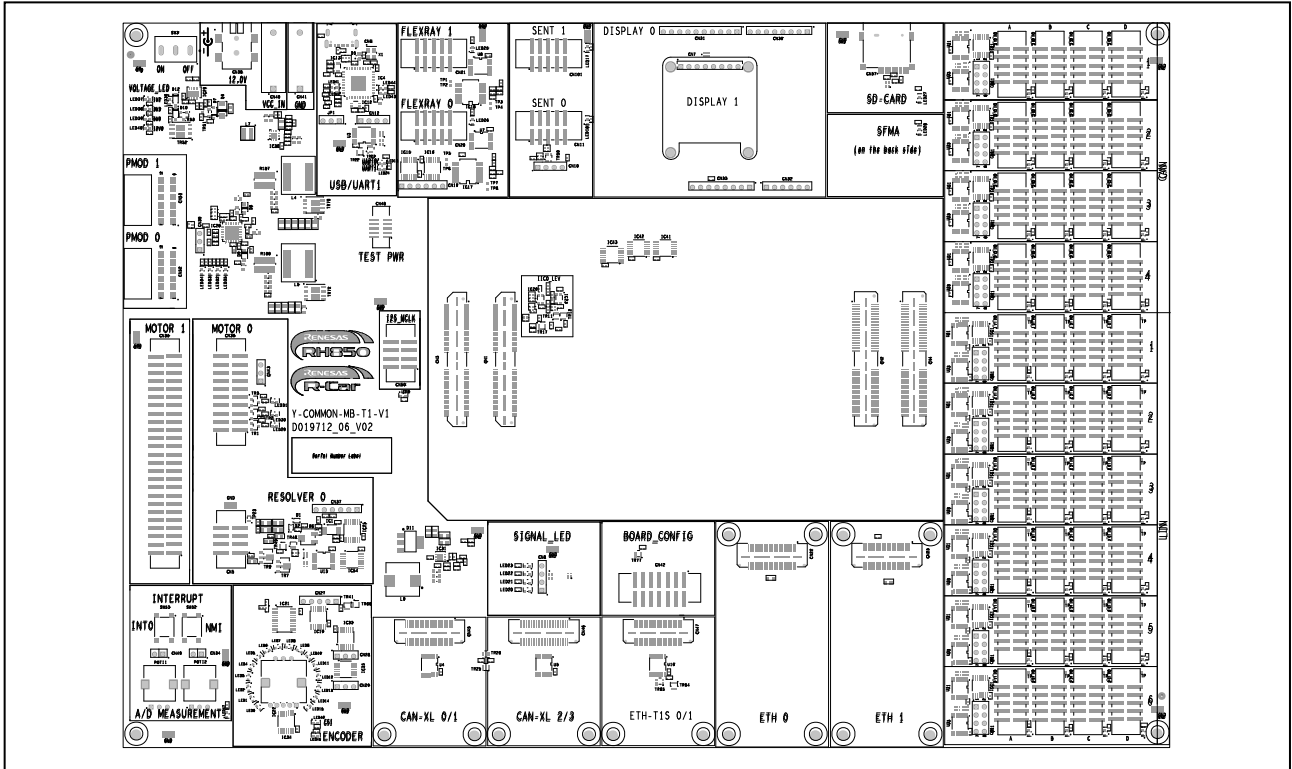

Figure 2.3 Placement of switches, connectors and LEDs on top side of board version D019712_06_V02

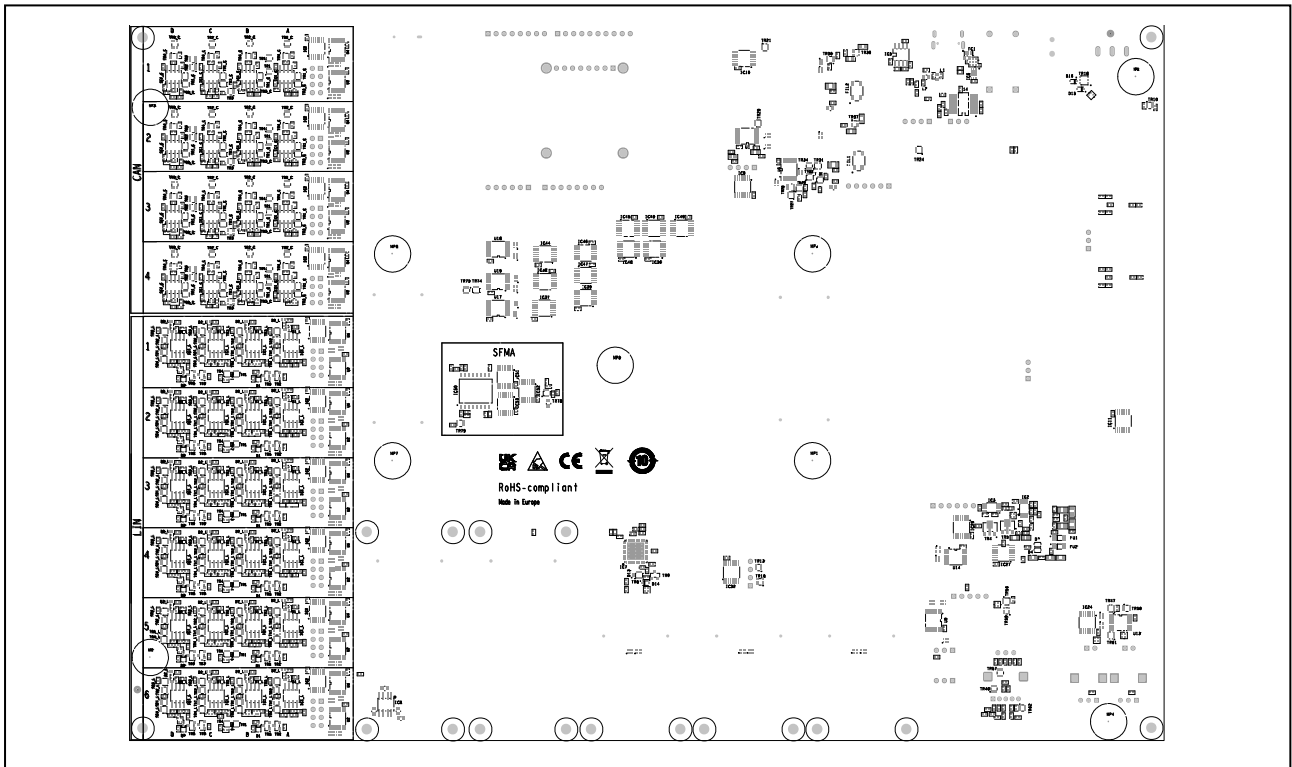

Figure 2.4 Placement of switches, connectors and LEDs on bottom side of board version D019712_06_V02

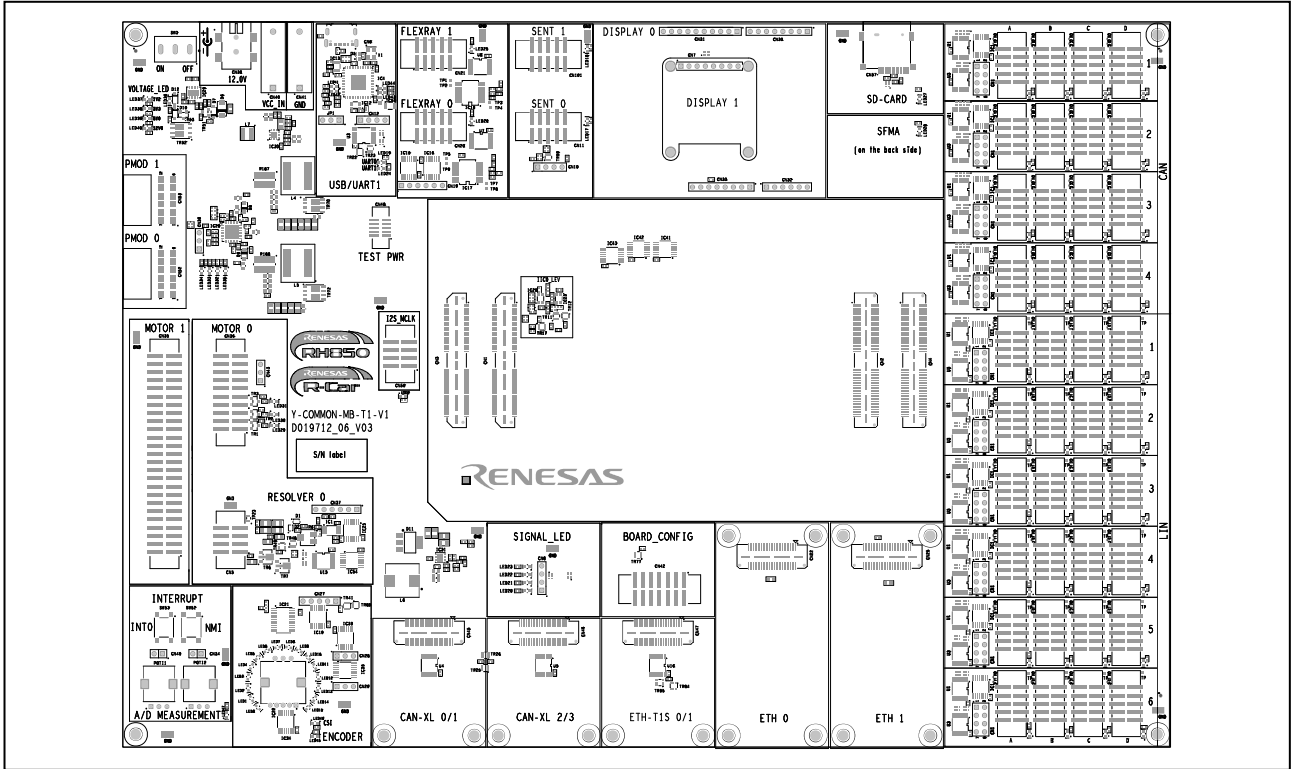

Figure 2.6 Placement of switches, connectors and LEDs on bottom side of board version D019712_06_V03

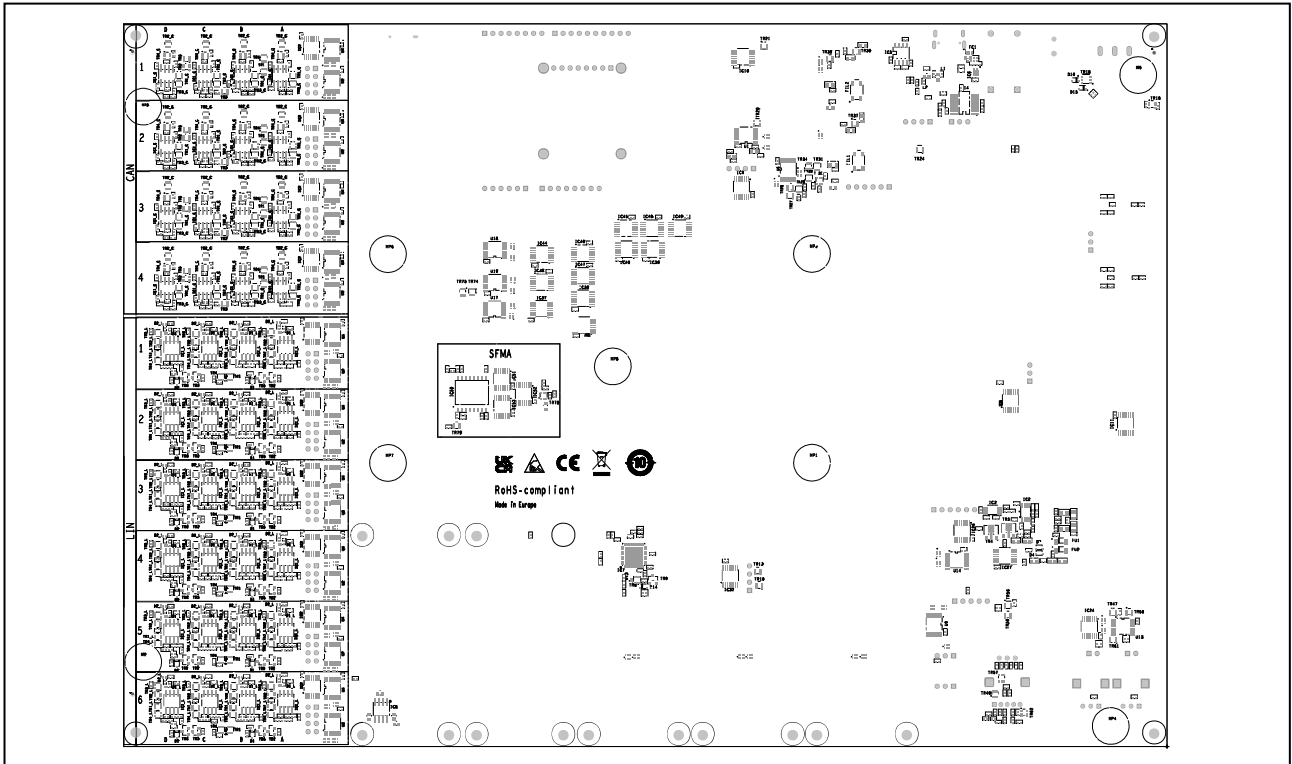

Figure 2.5 Placement of switches, connectors and LEDs on top side of board version D019712_06_V03

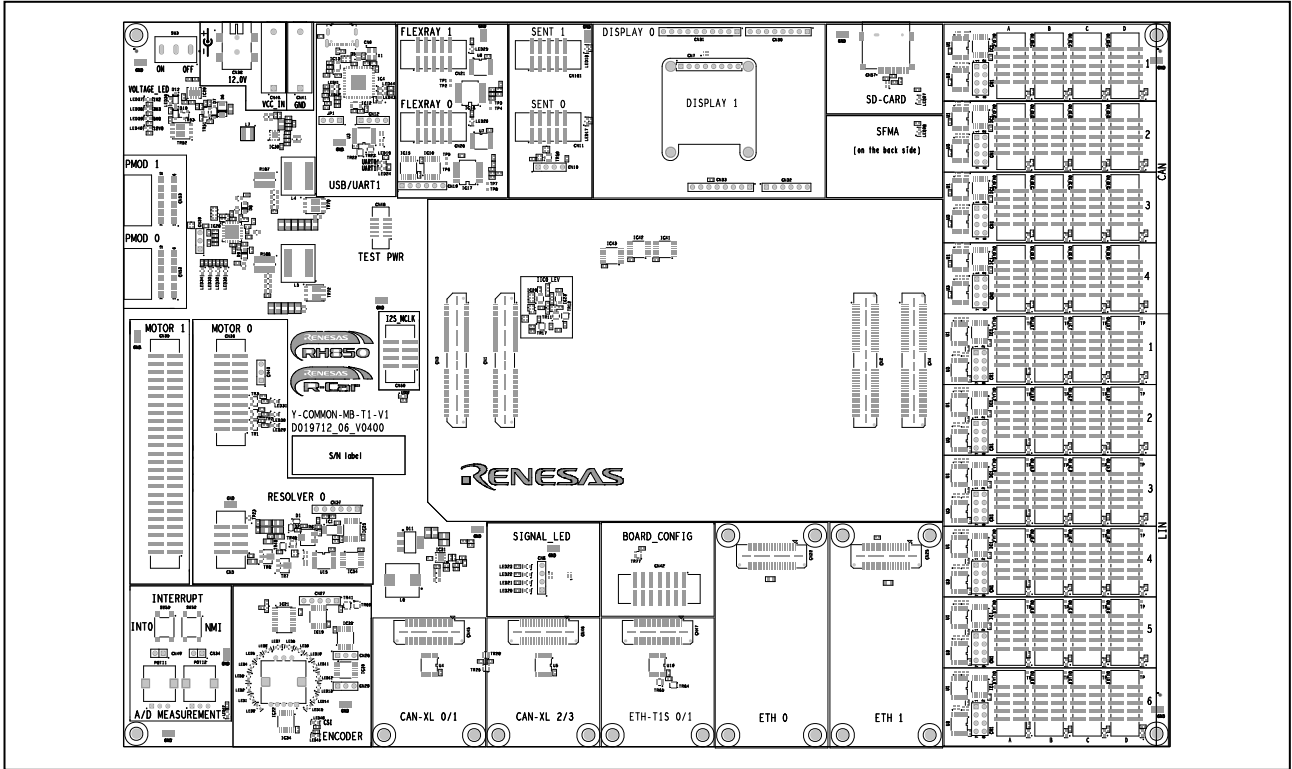

Figure 2.7 Placement of switches, connectors and LEDs on bottom side of board version D01912_06_V04

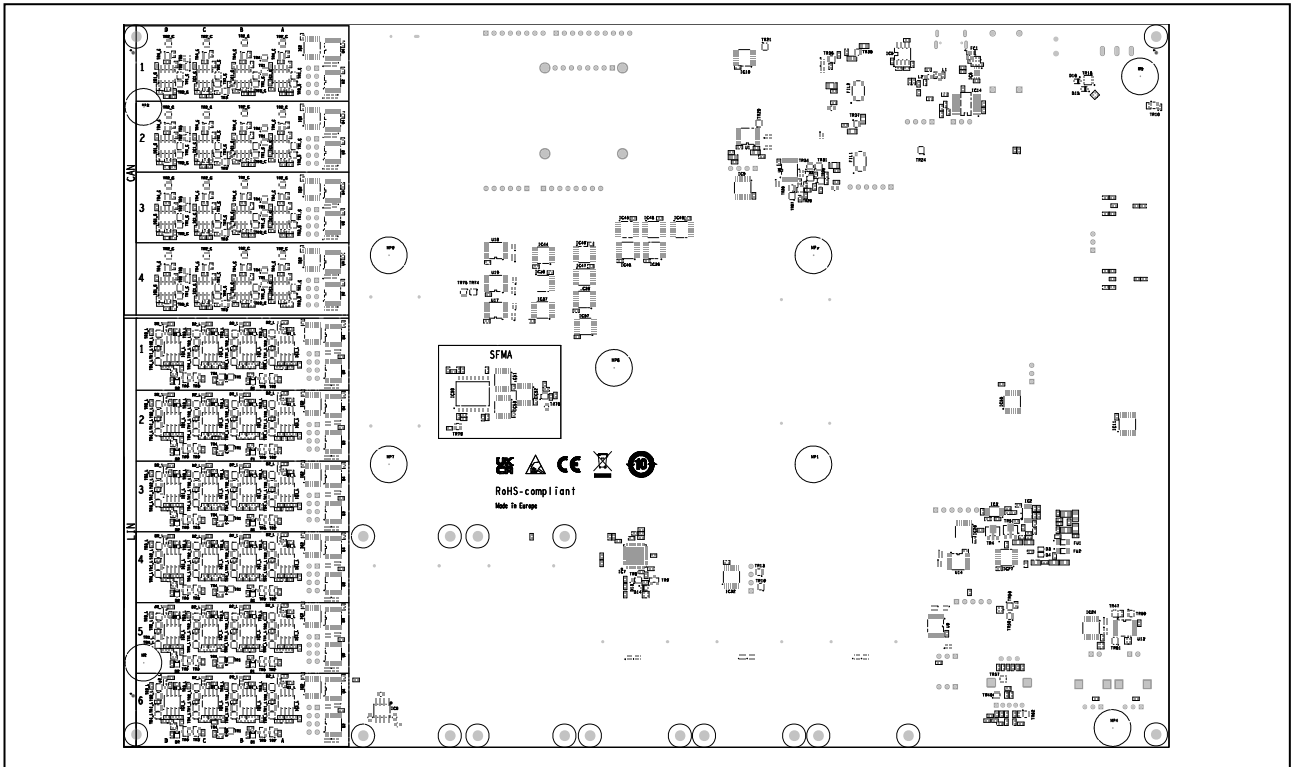

Figure 2.8 Placement of switches, connectors and LEDs on top side of board version D01912_06_V04

2.1 Switches Overview

The following table provides an overview of all switches.

Table 2.1 Switches overview

Switch	Function	Remark
SW3	Power switch	refer to 3 <i>Power Supply</i>
SW52	External interrupt switch	refer to 5.18 <i>Interrupt Push Buttons</i>
SW53		

2.2 Jumper Overview

This main board has only a single jumper JP1.

JP1 is used to select the interface being connected to connector CN1_LA_1. Connector CN1_LA_1 can be used for UART0 or LIN0 interface. Please refer to chapter 5.2 *LIN Interfaces*.

2.3 LEDs Overview

The following table provides an overview of all LEDs.

From board version D019712_06_V02 onwards power supply LEDs have been added to all peripheral circuits indicating peripherals that have been switched on. Such power supply LEDs were not included in board version D019712_06_V01

Table 2.2 LEDs overview (cont'd)

LED	Function	Color	Remark
LED0 – LED15	Circular ring LED	blue	refer to 5.15 <i>LED CSI Driver for LED Ring Indicator</i>
LED1_LA_1 - LED1_LA_6	Power on LED for LIN interfaces (not board version D019712_06_V01)	green	refer to 5.2 <i>LIN Interfaces</i>
LED1_LB_1 - LED1_LB_6			
LED1_LC_1 - LED1_LC_6			
LED1_LD_1 - LED1_LD_6			
LED1_CA_1 - LED1_CA_4	Power on LED for CAN interfaces (not board version D019712_06_V01)	green	refer to 5.3 <i>CAN Interfaces</i>
LED1_CB_1 - LED1_CB_4			
LED1_CC_1 - LED1_CC_4			
LED1_CD_1 - LED1_CD_4			
LED16	Power on LED for IIC0 level shifter (not board version D019712_06_V01)	green	refer to 5.22 <i>IIC Level Shifter</i>
LED17	Power on LED for SENT0 interface (not board version D019712_06_V01)	green	refer to 5.7 <i>SENT (Single Edge Nibble Transmission) Interfaces</i>

Table 2.2 LEDs overview (cont'd)

LED	Function	Color	Remark
LED18	Power on LED for SENT1 interface (not board version D019712_06_V01)	green	
LED19	Power on LED for UART0 interface (not board version D019712_06_V01)	green	refer to 5.8 <i>UART Interfaces</i>
LED20 – LED23	Signal LED	blue	refer to 5.20 <i>Signal LEDs</i>
LED24	Power on LED for UART1 interface (not board version D019712_06_V01)	green	refer to 5.8 <i>UART Interfaces</i>
LED25	Power on LED for FLEXRAY1 interface (not board version D019712_06_V01)	green	refer to 5.5 <i>FlexRay Interfaces</i>
LED26	Power on LED for FLEXRAY0 interface (not board version D019712_06_V01)	green	
LED27	Power on LED for SD card interface (not board version D019712_06_V01)	green	refer to 5.11 <i>MicroSD Card Interface</i>
LED28	Power on LED for serial flash memory (not board version D019712_06_V01)	green	refer to 5.10 <i>Serial Flash Memory</i>
LED29	Motor0 LED phase U	red	refer to 5.16 <i>Motor Control Circuit</i>
LED30	Motor0 LED phase V	green	
LED31	Motor0 LED phase W	blue	
LED32	Status signals of voltage regulator IC	red	refer to 3.3 <i>Voltage Regulator Circuits</i>
LED33		red	
LED34		green	
LED35		red	
LED36	Reverse voltage protection	red	refer to 3.2 <i>Reverse Voltage Connection Protection</i>
LED37	1.2 V power supply VCC1V2	blue	refer to 3.5 <i>Voltage Level LEDs</i>
LED38	3.3 V power supply VSYS3V3	blue	
LED39	5.0 V power supply VSYS5V0	blue	
LED40	12.0 V power supply VCC12V0	blue	
LED41	UART1 RxD LED	green	refer to 5.8 <i>UART Interfaces</i>
LED42	UART1 TxD LED	red	
LED43	UART1 RxD LED (RL78)	green	
LED44	UART1 TxD LED (RL78)	red	
LED45	Power on LED for rotary encoder (not board version D019712_06_V01)	green	refer to 5.14 <i>RGB Illuminated Rotary Encoder</i>
LED46	Power on LED for circular ring LED (not board version D019712_06_V01)	green	refer to 5.15 <i>LED CSI Driver for LED Ring Indicator</i>
LED47	Power on LED for ADC inputs (not board version D019712_06_V01)	green	refer to 5.19 <i>A/D Measurements</i>

2.4 Connectors Overview

The following table provides an overview of all connectors.

Note

Only connect a function of the main board to the piggyback board if the function is used. If a function is not used, remove any related module or jumper. Otherwise, it might interfere with other functions shared on the same port of an attached piggyback board.

Table 2.3 Connectors overview (cont'd)

Connector	Function	Remark
CN1	Piggyback board connectors	refer to 5.1 <i>Piggyback Board</i>
CN2		
CN3		
CN4	Piggyback board connector (not assembled)	reserved for future use
CN1_1	Connector to monitor LIN interface signals	refer to 5.2 <i>LIN Interfaces</i>
CN1_2		
CN1_3		
CN1_4		
CN1_5		
CN1_6		
CN1_LA_1 - CN1_LA_6	LIN interface connector	
CN1_LB_1 - CN1_LB_6		
CN1_LC_1 - CN1_LC_6		
CN1_LD_1 - CN1_LD_6		
CN1_C1	Connector to monitor CAN interface signals	refer to 5.3 <i>CAN Interfaces</i>
CN1_C2		
CN1_C3	Connector to monitor CAN interface signals	refer to 5.3 <i>CAN Interfaces</i>
CN1_C4		
CN1_CA_1 - CN1_CA_4	CAN interface connector	
CN1_CB_1 - CN1_CB_4		
CN1_CC_1 - CN1_CC_4		
CN1_CD_1 - CN1_CD_4		
CN5	Connector for external resolver 0	refer to 0 Resolver Circuit
CN6	USB-connector to UART1 via USB to UART IC	refer to 5.8 <i>UART Interfaces</i>

Main Board for RH850 and R-Car U5x 2. Switches, Connectors, Jumpers, and LEDs

Table 2.3 Connectors overview (cont'd)

Connector	Function	Remark
CN7	Connector for OLED display	refer to 5.12.2 <i>OLED Graphic Display</i>
CN8	External connector for user LEDs: LED20 – LED23	refer to 5.20 <i>Signal LEDs</i>
CN10	Connector to monitor SENT interface signals	refer to 5.7 <i>SENT (Single Edge Nibble Transmission) Interfaces</i>
CN11	SENT0 interface connector	
CN12	Connector to monitor UART interface signals	refer to 5.8 <i>UART Interfaces</i>
CN19	Connector to monitor FlexRay interface signals	refer to 5.5 <i>FlexRay Interfaces</i>
CN20	FLEXRAY0 interface connector	
CN21	FLEXRAY1 interface connector	
CN22	Ethernet0 module connector (MII)	refer to 5.6.1 <i>Ethernet Modules Supporting MII/SGMII</i>
CN25	Ethernet1 module connector (MII)	
CN27	Connector to monitor LED / CSI signals	refer to 5.15 <i>LED CSI Driver for LED Ring Indicator</i>
CN28	Connector to RGB signals for encoder shaft illumination	refer to 5.14 <i>RGB Illuminated Rotary Encoder</i>
CN29	Connector to monitor encoder signals	
CN30	Connectors for 2.8" touch display (Y-RH850-TFT-EXT-BRD)	refer to 5.12.1 <i>TFT Display</i>
CN31		
CN32		
CN33		
CN34	Analog signal for ADC[0..1]	refer to 5.19 <i>A/D Measurements</i>
CN35	MOTOR1 motor control signals	refer to 5.16 <i>Motor Control Circuit</i>
CN36	MOTOR0 motor control signals	
CN37	Connector to resolver signals	refer to 0 <i>Resolver Circuit</i>
CN38	Power supply connector 12V	refer to 3 <i>Power Supply</i>
CN39	GND connection	
CN40	Power supply connector 12V	refer to 3 <i>Power Supply</i>
CN41	Power supply connector GND	
CN42	Debug connector for RL78/F13	refer to 4 <i>Main Board Configuration</i>
CN43	MOTOR0 motor control signals	refer to 5.16 <i>Motor Control Circuit</i>
CN45	CAN XL module connector	refer to 5.4 <i>CAN XL Modules</i>
CN46		
CN47	Ethernet module connector 10BASE-T1S	refer to 5.6.2 <i>Ethernet Modules Supporting T1S</i>
CN48	Power test connector	refer to 3 <i>Power Supply</i>
CN49	Inputs for external interrupts NMI and INTO	refer to 5.18 <i>Interrupt Push Buttons</i>
CN50	I2S MCLK connector	refer to 5.21 <i>I2S Interface</i>
CN52	Pmod™ signal connector	refer to 5.13 <i>Pmod™ Interfaces</i>
CN53		

Table 2.3 Connectors overview (cont'd)

Connector	Function	Remark
CN57	SD card connector	refer to 5.11 <i>MicroSD Card Interface</i>
CN101	SENT1 interface connector	refer to 5.7 <i>SENT (Single Edge Nibble Transmission) Interfaces</i>

3. Power Supply

3.1 Board Power Connection

The main board is operated with a single external 12 V power supply via two banana-type plugs or a barrel connector as shown in *Figure 3.1* and *Figure 3.2*:

- CN38: barrel connector ()
- CN40: red banana jack for typ. +12V
- CN41: black banana jack for GND

All other supply voltages for the main and the piggyback board are generated on the main board using voltage regulators.

All on-board generated voltages are connected to the pin header CN48 for measurement purposes.

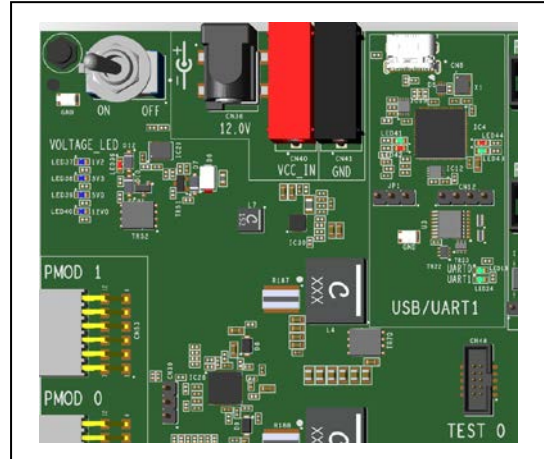

Figure 3.1 Power supply connectors

Table 3.1 Supply voltages pin header CN48

Pin	Voltage
1	GND
3	VSYS12V0
5	VSYS3V3
7	VCP_OUT5V#
9	NC

Pin	Voltage
2	VBAT
4	VSYS5V0
6	VCC1V2
8	NC
10	GND

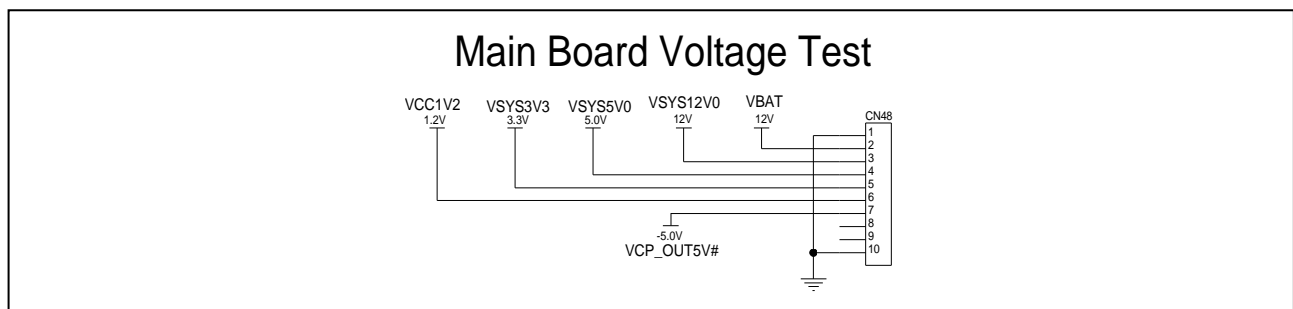

Figure 3.2 Connector to measure main board voltages

Note

Within this document all voltage values are considered as 'typical'.

Please refer to the 'Electrical Characteristics' section of the Hardware User's Manual for allowed voltage ranges.

3.2 Board Power Switch, Reverse Voltage Connection Protection

The entire board power supply can be switched on or off via the switch SW3.

The board is protected against reverse connection of the external power supply via CN38, or CN40 and CN41.

Figure 3.3 and Figure 3.4 show the connection of the external power supply and the board protection circuit.

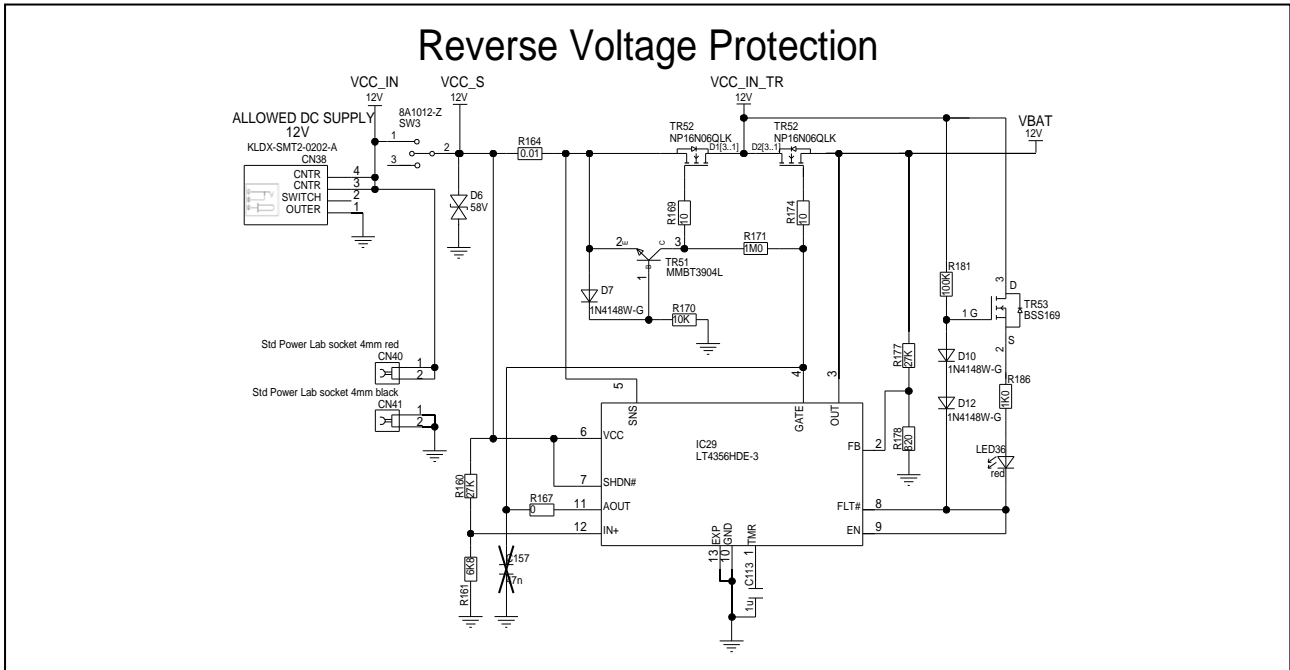

Figure 3.4 Connection of power supply and board protection circuit of board version D019712_06_V01

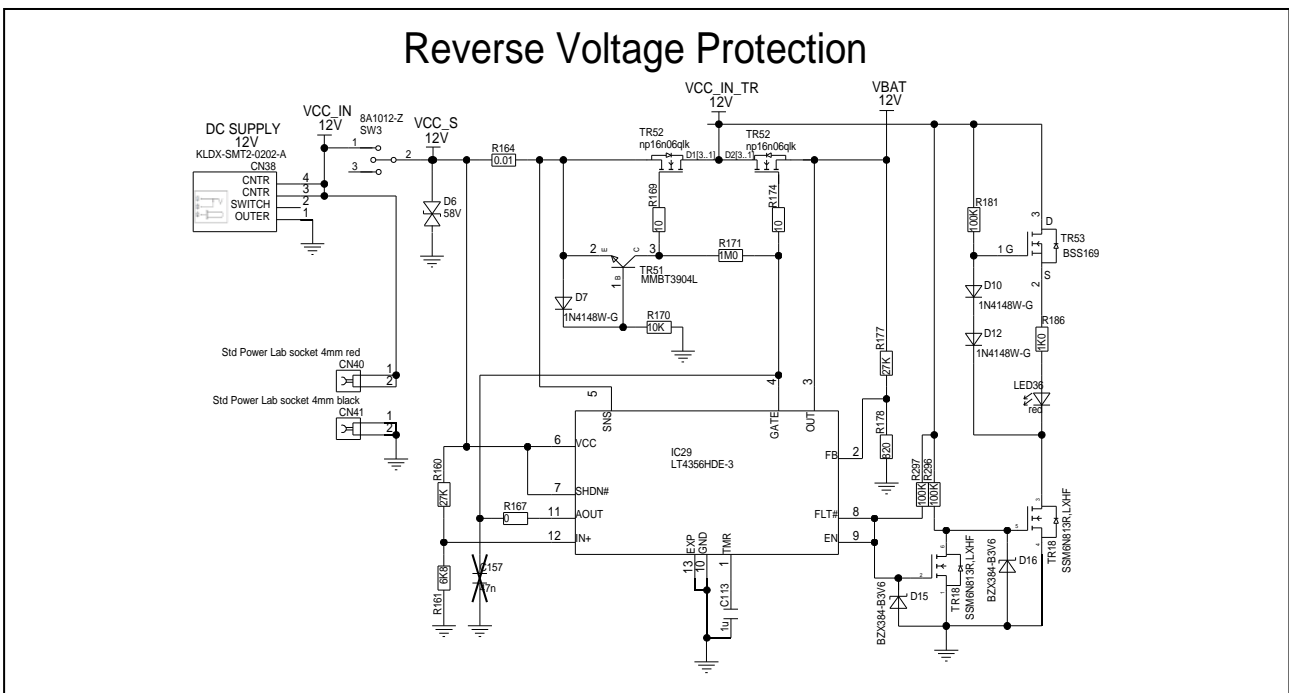

Figure 3.3 Connection of power supply and board protection circuit of board version D019712_06_V02 and later

3.3 Voltage Regulator Circuits

Figure 3.5 to Figure 3.7 show the voltage regulator circuits that generate the necessary voltage levels.

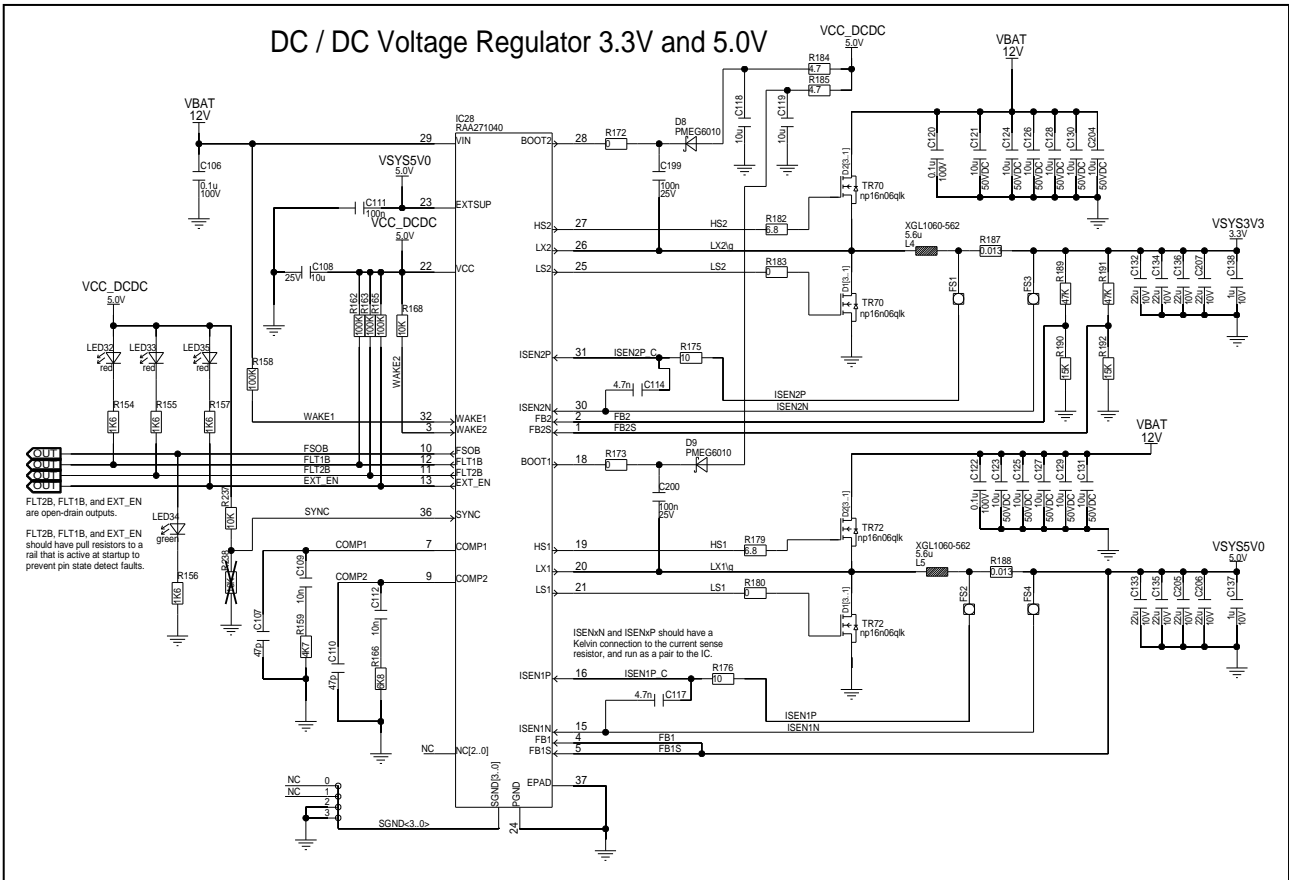

Figure 3.6 Voltage regulator 3.3V / 5.0V

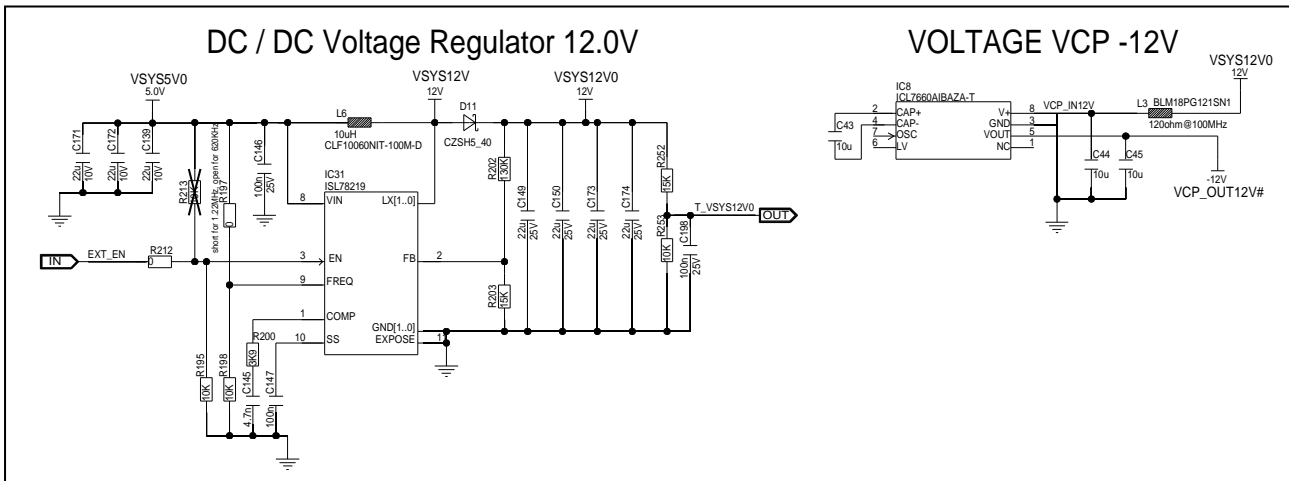

Figure 3.5 Voltage regulator +- 12.0V

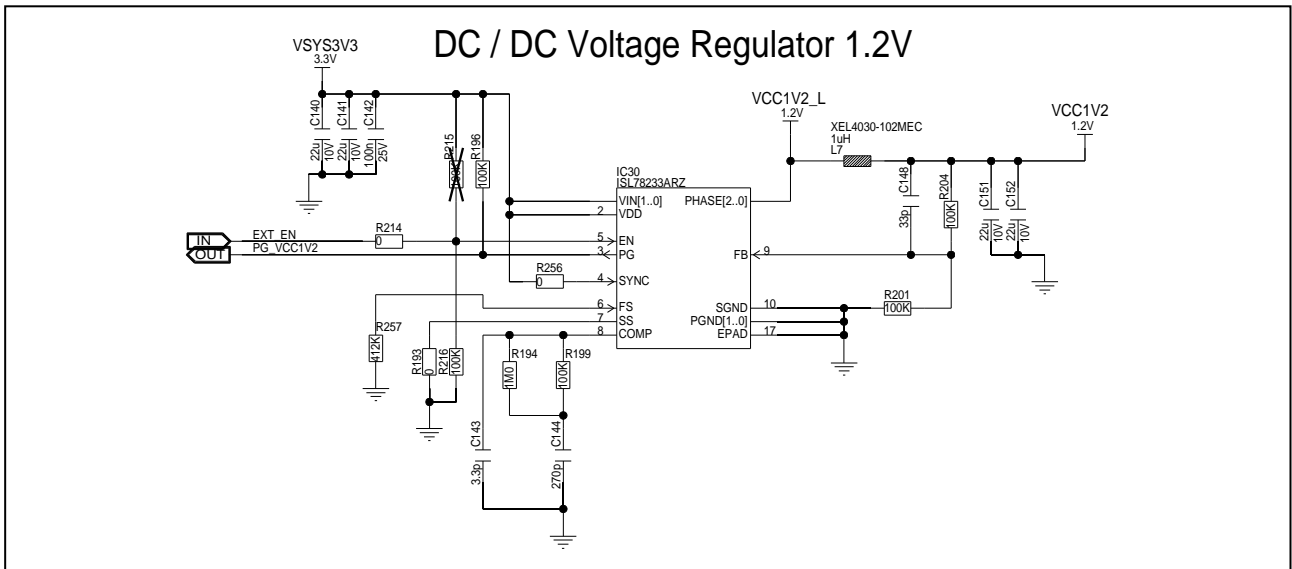

Figure 3.7 Core voltage regulator 1.2V

3.4 Peripheral Supply Voltage VDDIOF

The peripheral supply voltage VDDIOF is provided from the piggyback board via the connectors CN1. The VDDIOF voltage level is determined by the piggyback board.

All peripheral circuits on the main board have their own supply voltage control. VDDIOF from the piggyback board is NOT used as supply voltage for the peripheral circuits on the main board.

The supply voltages for the peripherals are derived from the voltage regulators for VSYS3V3 or VSYS5V0 on the main board. The supply voltage for each peripheral is controlled separately by the main board configurator. The circuit diagrams in Figure 3.8 to Figure 3.13 show the circuits for various peripheral power supplies as they are implemented on different board versions.

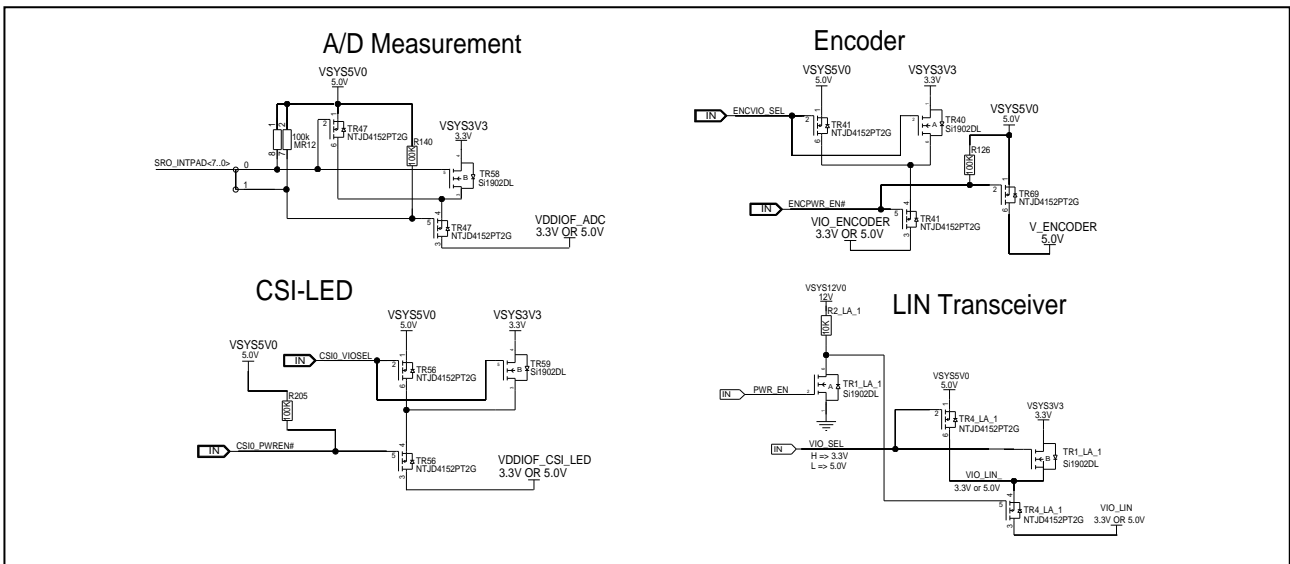

Figure 3.8 VDDIOF for peripheral circuits (1) of board version D019712_06_V01

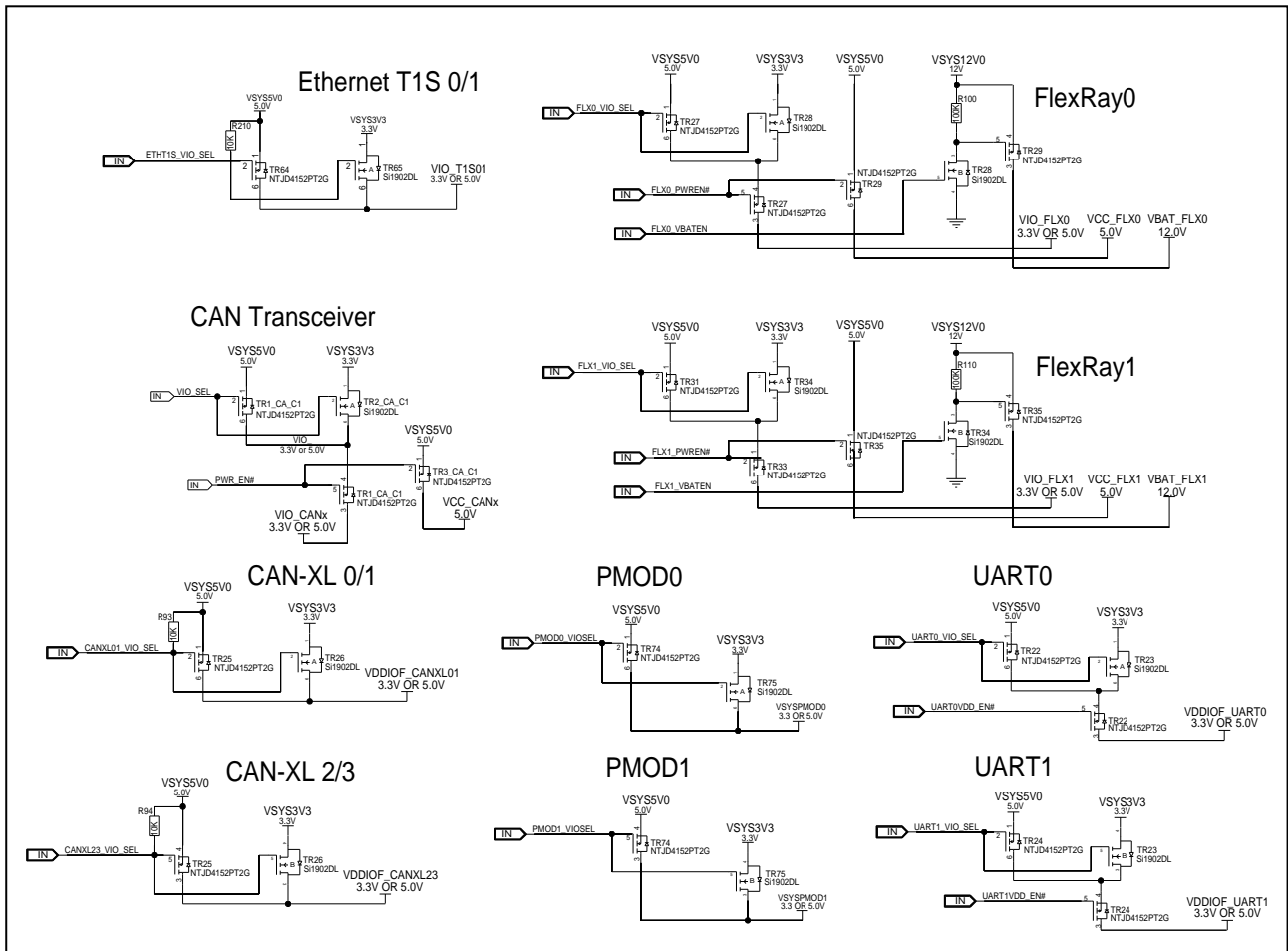

Figure 3.9 VDDIOF for peripheral circuits (2) of board version D019712_06_V01

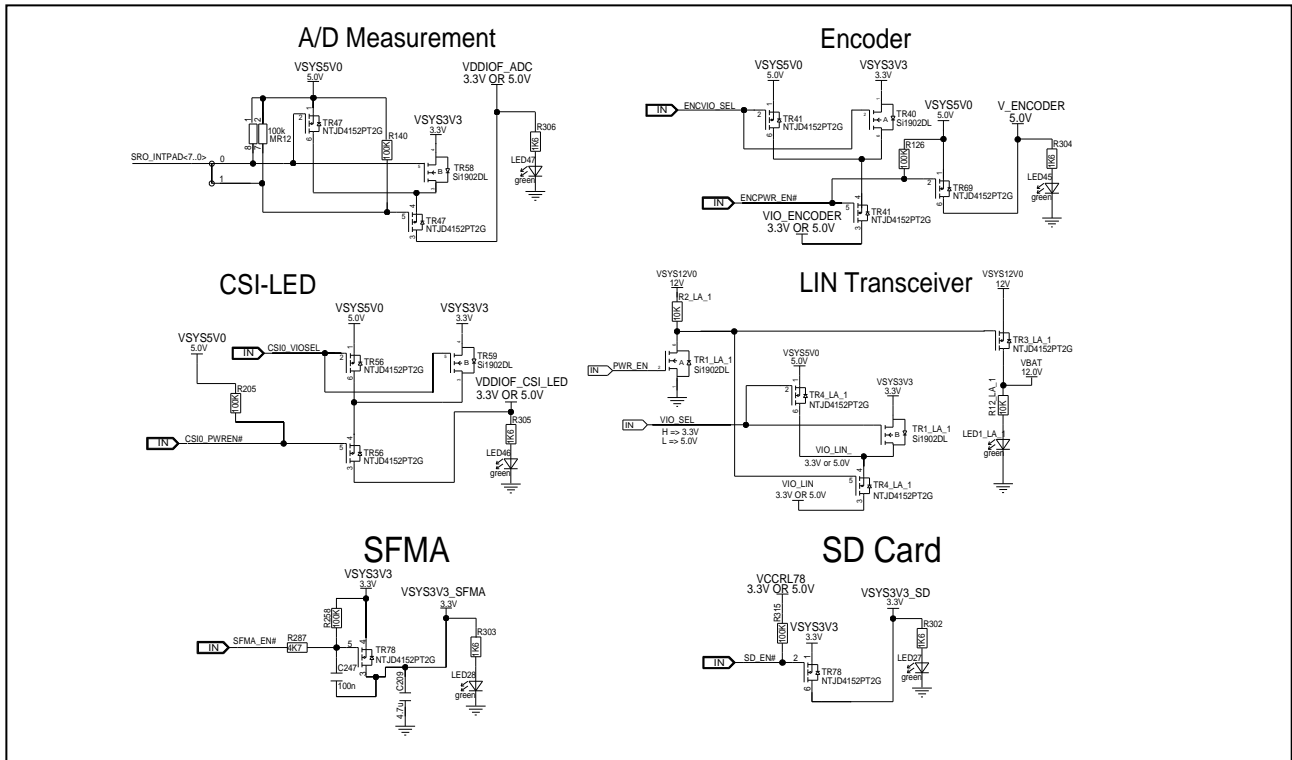

Figure 3.10 VDDIOF for peripheral circuits (1) of board version D019712_06_V02 and D019712_06_V03

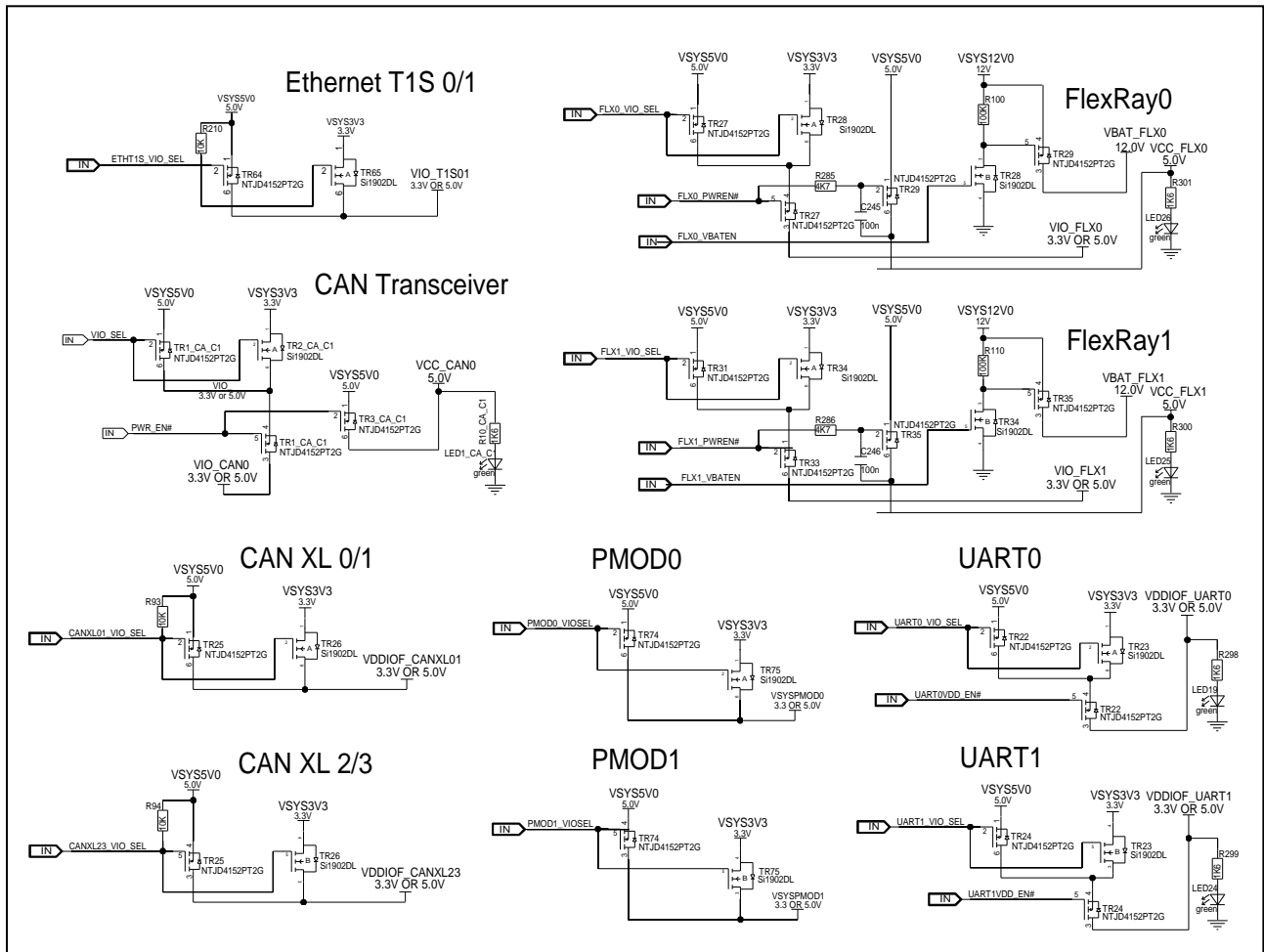

Figure 3.11 VDDIOF for peripheral circuits (2) of board version D019712_06_V02 and D019712_06_V03

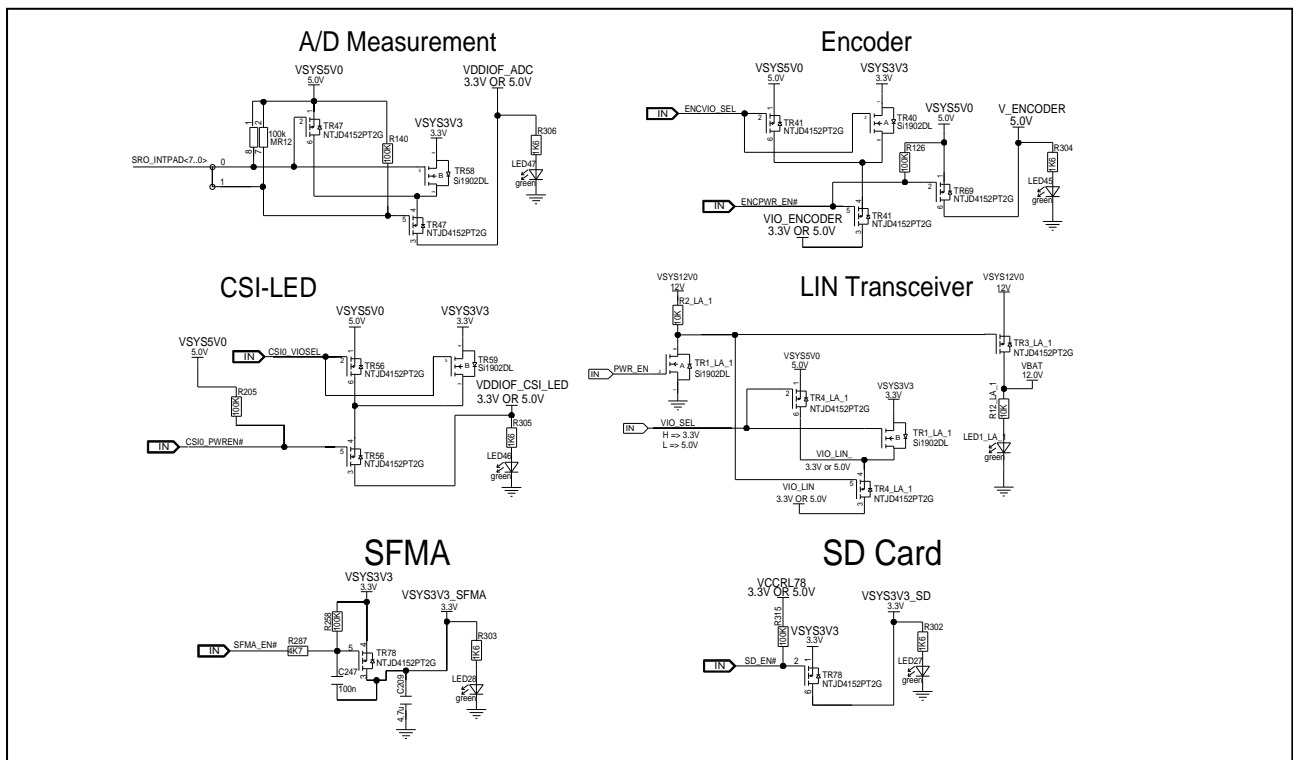

Figure 3.12 VDDIOF for peripheral circuits (1) of board version D019712_06_V04 and later

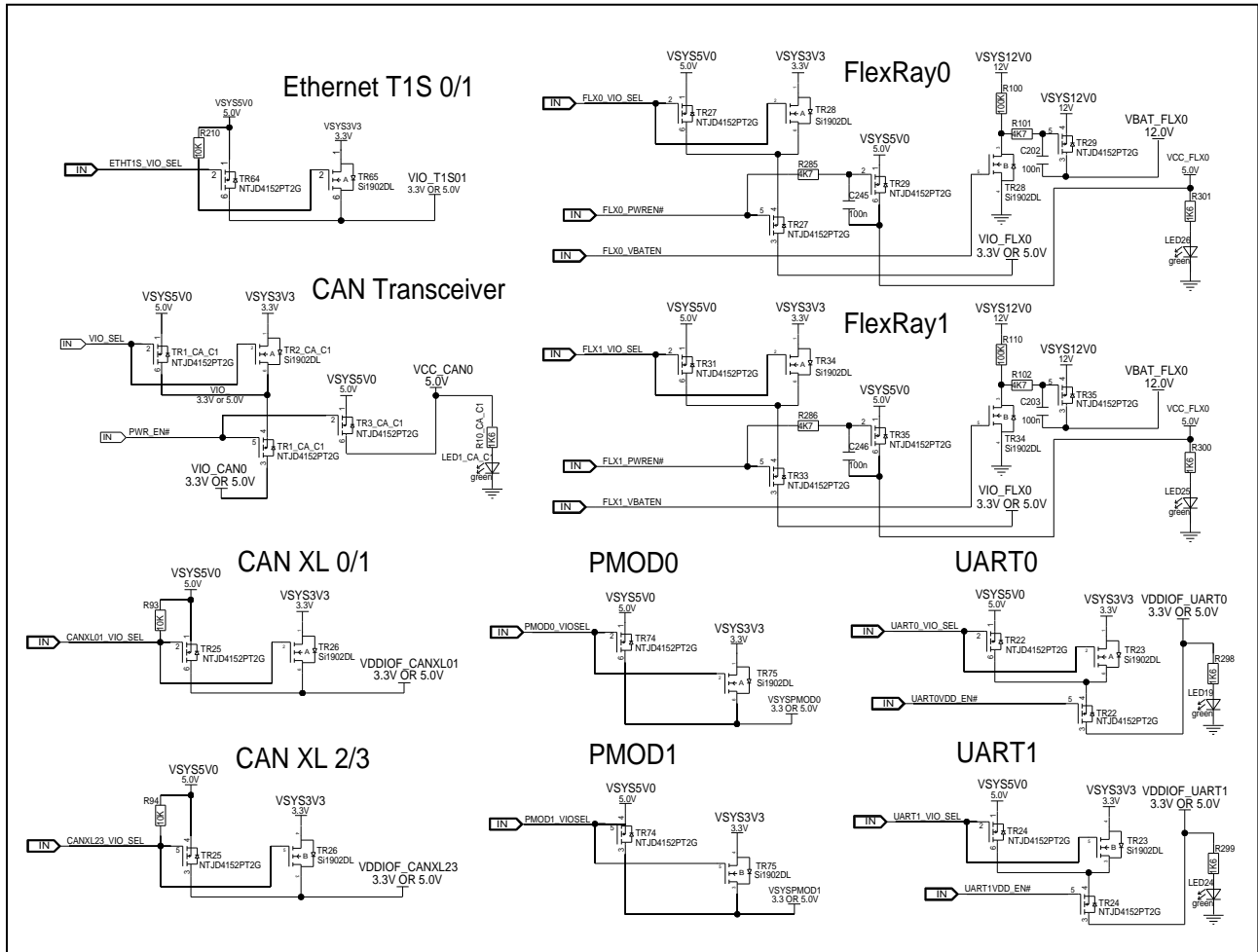

Figure 3.13 VDDIOF for peripheral circuits (2) of board version D019712_06_V04 and later

3.5 Voltage Level LEDs

The following blue LEDs indicate the availability of various voltages on the main board:

- LED37 for 1.2 V power rail VCC1V2
- LED38 for 3.3 V power rail VSYS3V3
- LED39 for 5.0 V power rail VSYS5V0
- LED40 for 12.0 V external power supply VSYS12V0

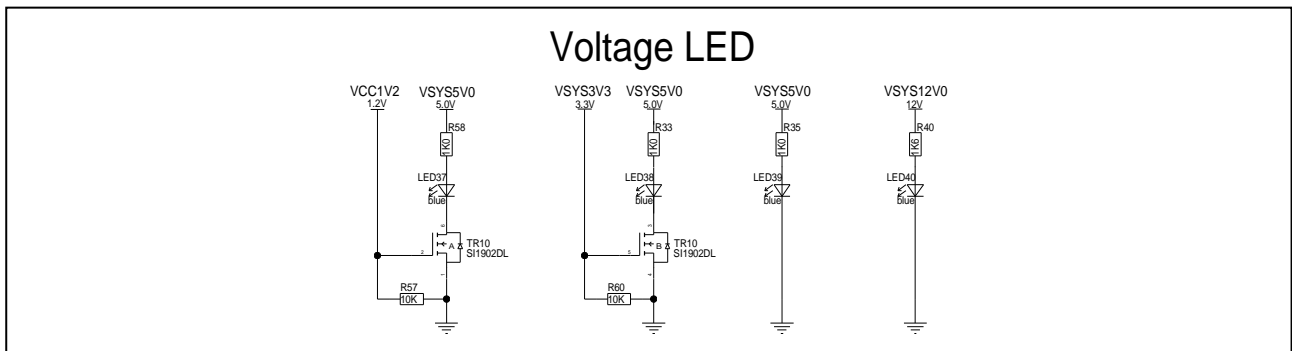

Figure 3.14 Power supply LEDs

4. Main Board Configuration

4.1 General description

Y-COMMON-MB-T1-V1 uses a design with only 1 jumper for main board configuration.

Main board configuration is implemented using an RL78/F13 device (IC7, R5F10BGGLNA).

The configuration is done in a PC based configuration software.

The configurator software for Windows PC and the firmware for the RL78 on the main board can be downloaded from the main board homepage ([Y-COMMON-MB-T1-V1](#)).

Configuration data is downloaded to RL78/F13 via virtual COM port using USB interface on connector CN6. Depending on the main board version connector CN6 uses a Micro-AB type connector or a USB-C connector. Refer to chapter 5.8 *UART Interfaces* for details on the UART interface.

RL78 then utilizes a synchronous interface on ports P10 – P14 to download the configuration to a series of shift registers, whose output ports are used to configure the peripheral circuits on the main board. *Figure 4.1* to *Figure 4.4* show the circuit diagram for RL78 for different board versions.

In case RL78/F13 is not programmed with the board configuration software or the software should be updated, the board has a built-in programmer interface on connector CN42. This can be used with E1 / E2 / E2 Lite emulator and Renesas Flash Programmer (RFP) software to program new software to RL78/F13.

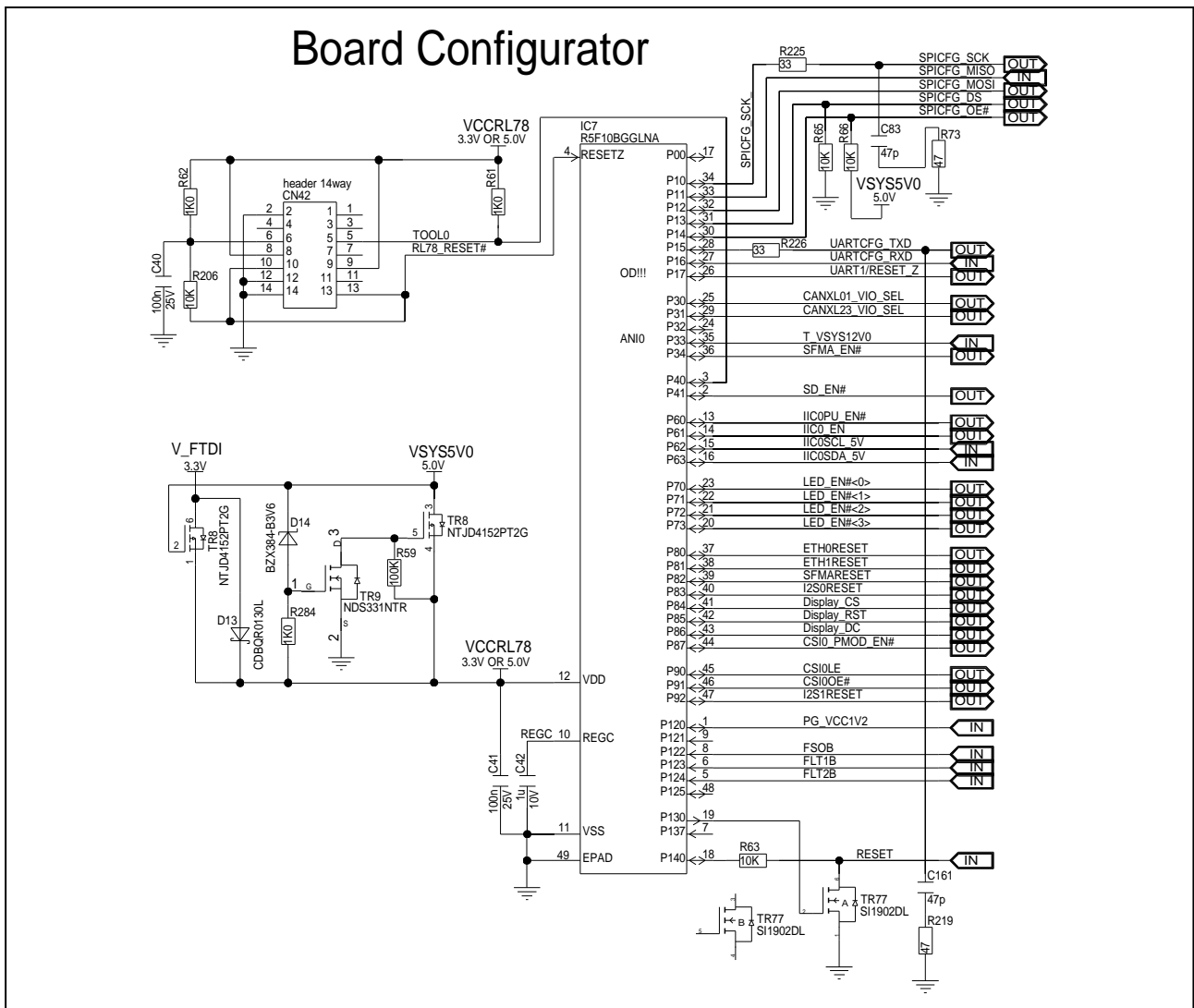

Figure 4.1 Main board configurator circuit using RL78/F13 of board version D019712_06_V01

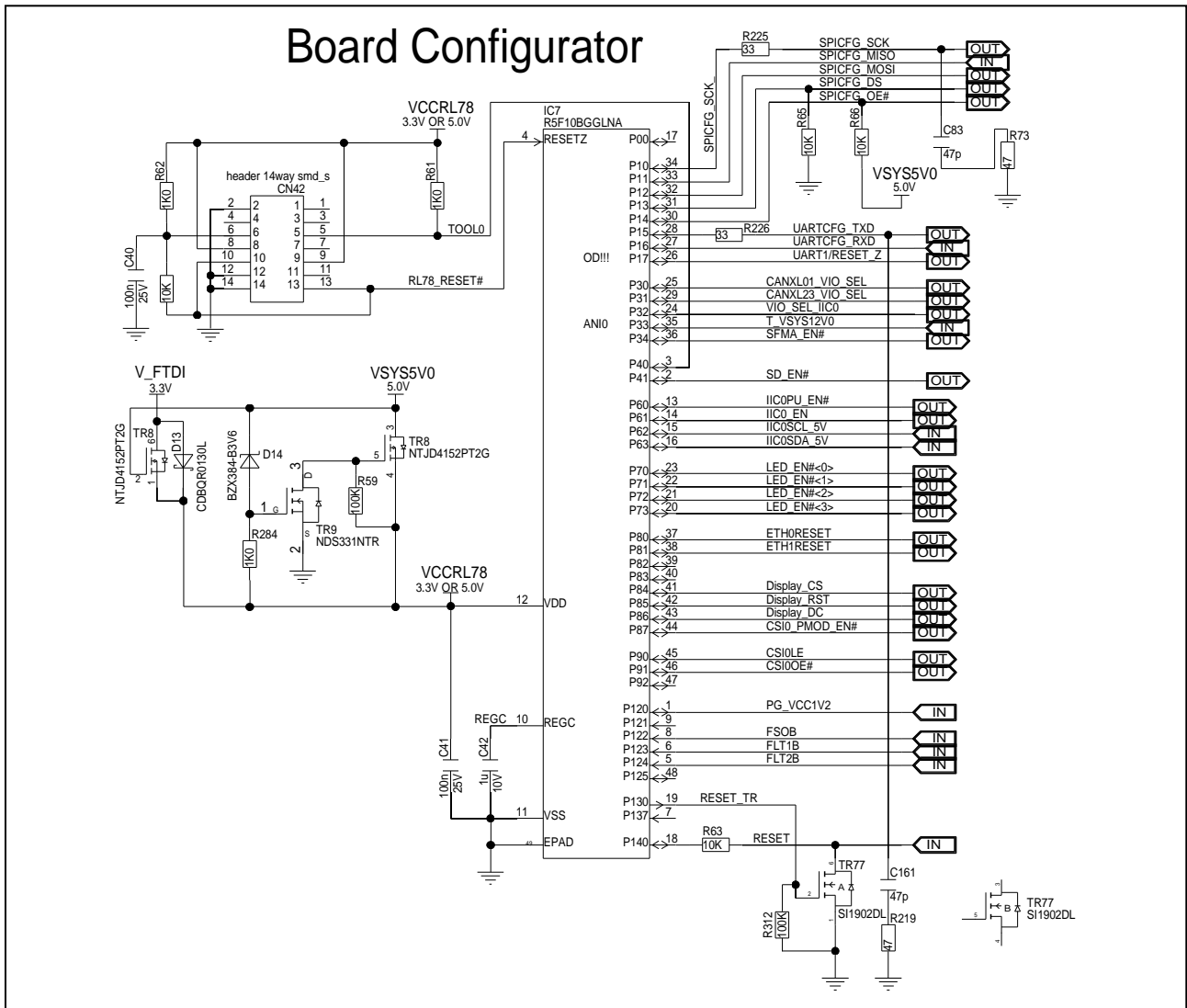

Figure 4.2 Main board configurator circuit using RL78/F13 of board version D019712_06_V02

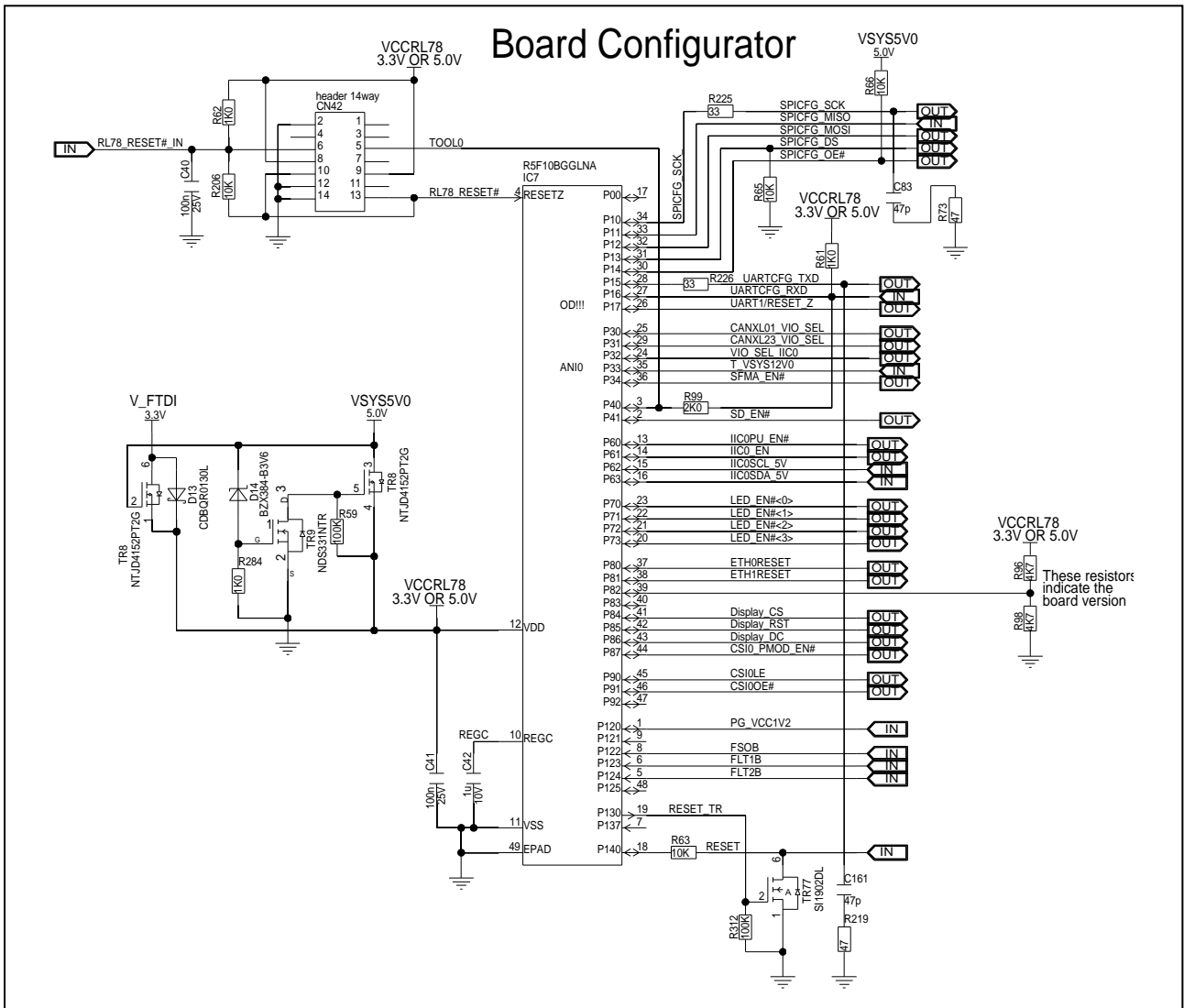

Figure 4.3 Main board configurator circuit using RL78/F13 of board version D019712_06_V03

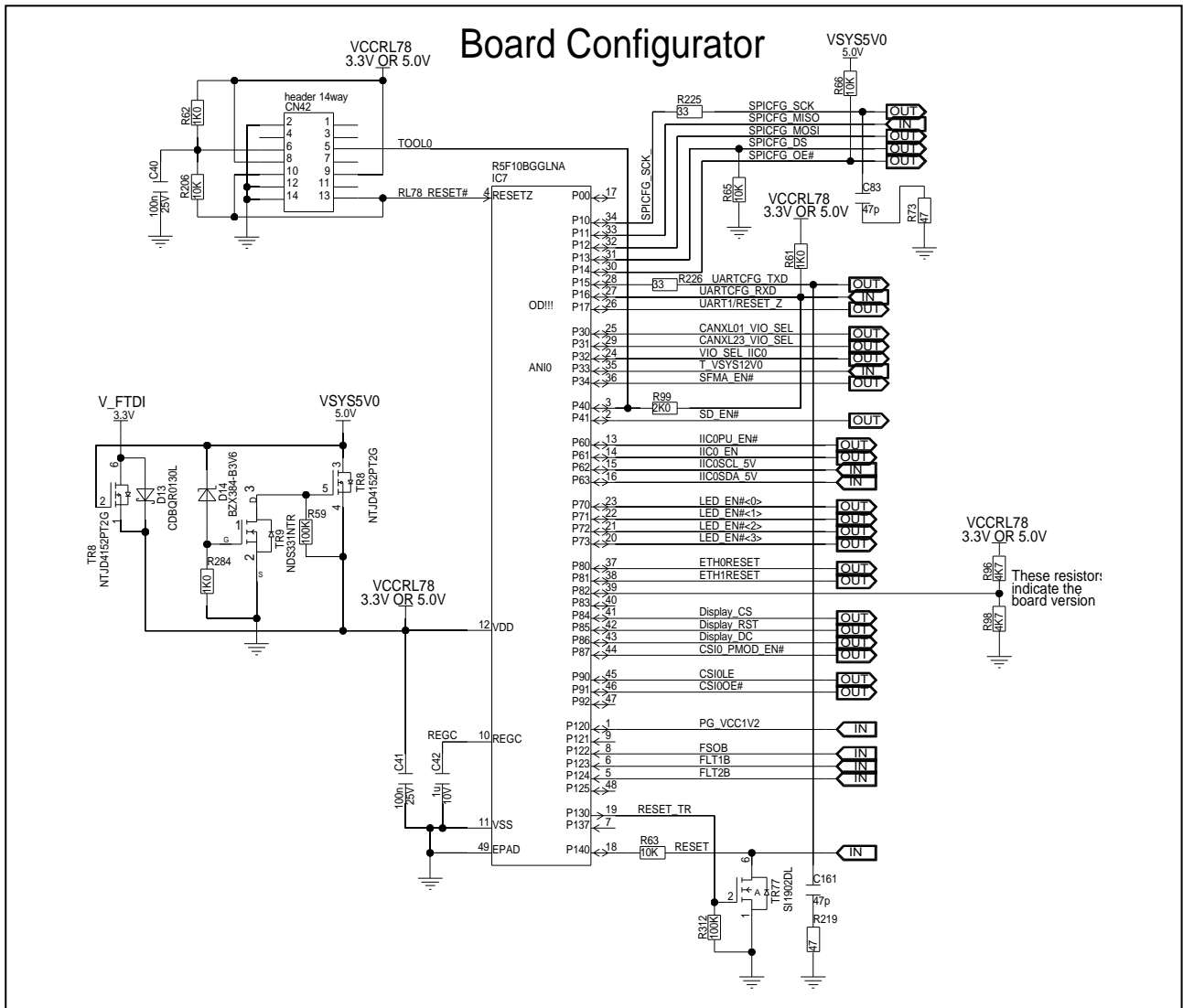

Figure 4.4 Main board configurator circuit using RL78/F13 of board version D019712_06_V04

4.2 Main Board Configurator Software

The main board is provided with a Microsoft-Windows based configuration software. This allows the activation and configuration of all on-board peripherals as well as some settings for the external modules like CAN XL, Ethernet and displays.

4.2.1 Main Board Connection

Connect a USB cable from the Micro-AB USB connector (board version D019712_06_V01) or the USB-C connector (board version D019712_06_V02 or later) to a USB port of your Windows PC.

When the board is connected the PC should recognize two virtual COM ports and initialize those automatically.

When you start the MB_Configurator software it will automatically look for these ports and use one of them to connect to the board. If the configurator does not find a main board it will show this error message:

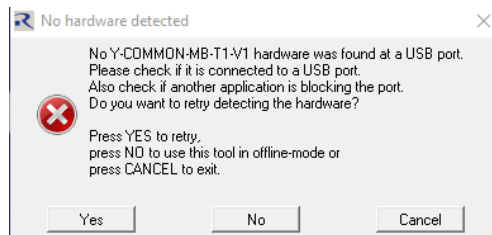

If you have your main board connected to your PC it may be that the serial ports have not been initialized. In this case, please check the windows device manager if the COM ports have been correctly initialized as shown below. Sometimes this initialization takes a little while.

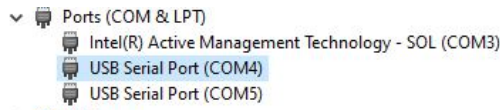

4.2.2 General Operation

When the main board configurator starts properly it shows such a start screen.

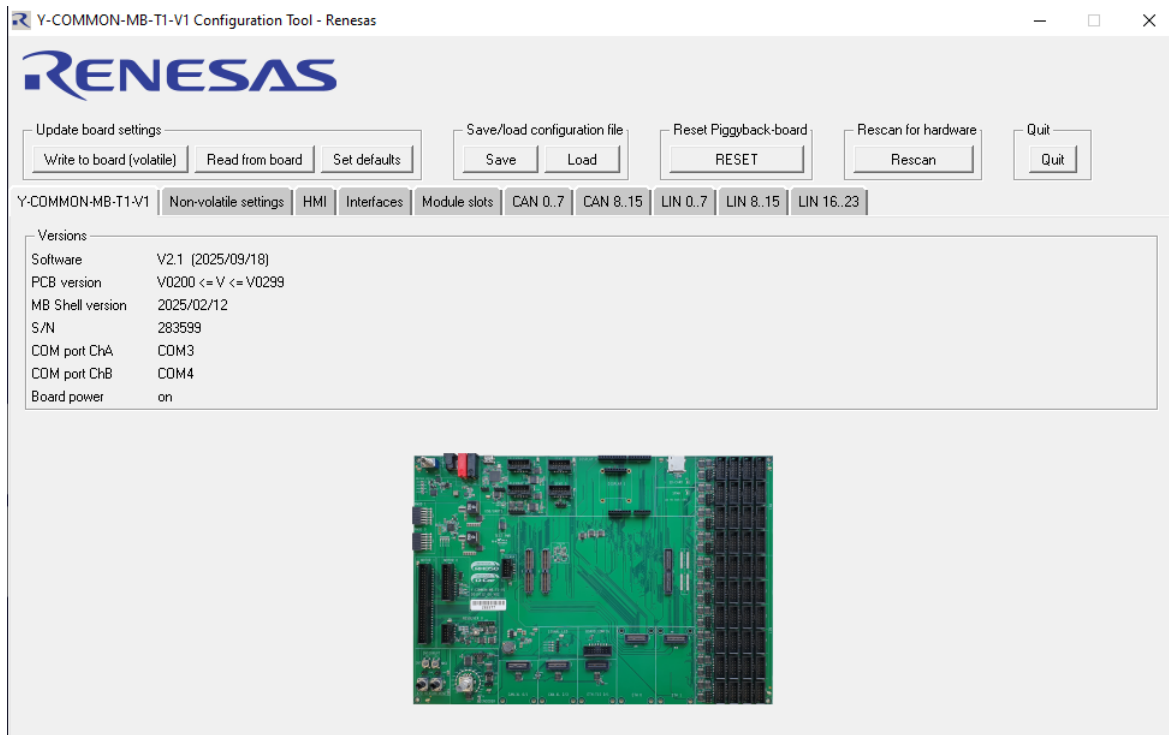

The buttons in the upper part are for general board operation.

- Group “Update board settings”
Using these buttons it is possible to download a configuration to the main board, read an active configuration from the main board and reset all peripheral settings in the configurator to a default value (all off).
- Group “Save/load configuration files”
It is possible to save a configuration to a simple text file and reload it from such a file.
- “Reset piggyback board”
- “Rescan for hardware”
- “Quit”

Below the buttons is a line of tabs for board control:

- “Y-COMMON-MB-T1-V1”
This gives a short summary of the main board. Most important are
 - The MB shell version. This is the software running on the RL78 in the main board. It is used to program the shift registers that are used to control the on-board peripheral circuits.
 - “Non-volatile settings”
The “Write to board (volatile)” button in the top row only writes the configuration data. If the configuration should be saved permanently on the main board you have to go to the “Non-volatile settings” tab.
With this function it is possible to save up to 4 configurations and make them bootable. A bootable configuration will be loaded automatically at power-on of the main board.

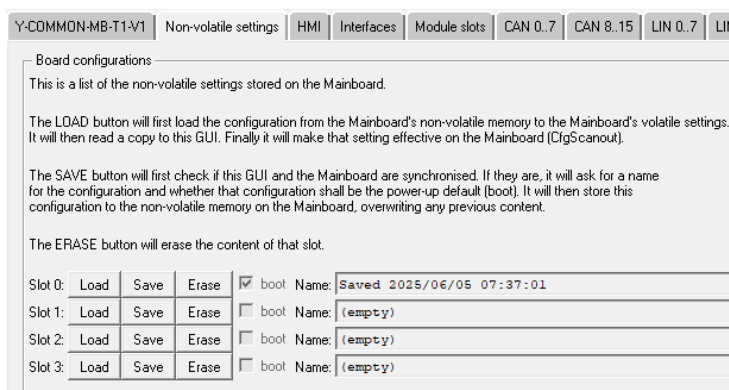

Note

Only one configuration can be bootable at a time. If more than one configuration is saved as “bootable”, then the configuration saved in the lowest slot is active and marked in the check box.

- “HMI”
The main board offers several means for user interaction, for example potentiometers, various LED, switches as interrupt inputs, a rotary encoder and display connectors for OLED or TFT displays.
- “Interfaces”
This tab is used to configure “non-CAN” and “non-LIN” interfaces included in the main board. These include for example FlexRay, SENT and UART interfaces.
- “Module slots”
In addition to the built-in interfaces the main board also includes some connectors where extension boards providing additional interfaces like Pmod™, CAN XL and Ethernet can plugged-in.
- “CAN” and “LIN”
The “CAN” and “LIN” tabs can be used to enable and configure each CAN and LIN channel separately.

4.2.3 Main Board Firmware Update

The main board includes a connector CN42, which can be used to update the firmware in RL78.

The firmware update is done using the Renesas Flash Programming software (RFP) and an E1 emulator, E2 emulator or E2 emulator Lite being used as flash programmer.

Note

The E2 emulator is connected to CN42 using the conversion adapter RTE0T00020KCA00000R. For programming RL78, switch SW1 on the conversion adapter must be set to position 3.

Otherwise, RFP cannot connect to RL78.

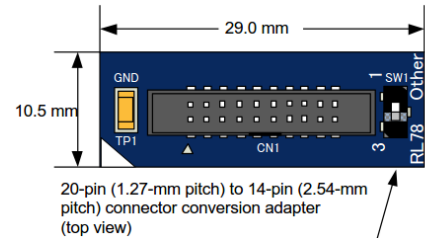

20-pin (1.27-mm pitch) to 14-pin (2.54-mm pitch) connector conversion adapter (top view)

The switch (SW1) must be in position 1 (labelled "Other") for RH850 or RX MCUs or in position 3 (labelled "RL78") for RL78 MCUs.

To reprogram the RL78 firmware on the main board follow this procedure:

1. Connect emulator E1, E2 or E2 Lite to connector CN42.
2. Start RFP software.
3. Create a new project for RL78 in RFP. The exact processor type is determined automatically when RFP connects to the target device on operation start.
4. There are 3 possibilities to provide the power supply to RL78:
 - From the USB connection on connector CN6.
 - From the board power supply on connector CN38.
 - From the emulator. In this case power supply must be switched on in the "Connect settings" in the RFP software.
5. Add the firmware file as "Program File" in RFP.
6. Push the "Start" button to execute the programming operation as defined in "Operation Settings"

5. Peripheral Circuits

The main board includes driver hardware for various interfaces (e.g. CAN, LIN, FlexRay, Ethernet) which is necessary to output the signals from the microcontroller to external hardware circuits. The microcontroller is mounted on a piggyback board that can be connected to the main board.

5.1 Piggyback Board

The main board has four connectors CN1-CN4 for connecting piggyback boards with different microcontrollers to this main board. However, up to now only the connectors CN1-CN3 are used by piggyback boards, and thus only these three connectors are assembled on the main board.

Regarding the function on the piggyback board, please refer to the User's Manual of the selected piggyback board.

For a list of applicable piggyback boards please refer to the "Related products" list via the following link:

[Y-COMMON-MB-T1-V1](#)

5.1.1 Piggyback Board Connectors

The signals of each connector are summarized in the following tables.

Table 5.1 Piggyback Board Connector CN1 pin assignment

Pin	Main board function	Pin	Main board function
1	VSYS5V0	2	VSYS5V0
3	VSYS5V0	4	VSYS5V0
5	RESET	6	NMI
7	WAKE	8	–
9	INT0	10	INT1
11	INT2	12	INT3
13	–	14	–
15	UART0TX	16	UART1TX
17	UART0RX	18	UART1RX
19	LIN0TX	20	LIN1TX
21	LIN0RX	22	LIN1RX
23	IIC0SCL	24	IIC1SCL
25	IIC0SDA	26	IIC1SDA
27	CAN0TX	28	CAN1TX
29	CAN0RX	30	CAN1RX
31	SENT0RX	32	SENT1RX
33	SENT0SPCO	34	SENT1SPCO
35	–	36	–
37	–	38	–
39	–	40	–
41	FLX0TX	42	FLX0TXE
43	FLX0RX	44	FLXSTPWT

Table 5.1 Piggyback Board Connector CN1 pin assignment (cont'd)

Pin	Main board function	Pin	Main board function
45	FLX1TX	46	FLX1TXE
47	FLX1RX	48	FLXCLK
49	–	50	–
51	ETH0MDIO	52	ETH0MDC
53	ETH0RXD0	54	EH0TXD0
55	ETH0RXD1	56	EH0TXD1
57	ETH0RXD2	58	EH0TXD2
59	ETH0RXD3	60	EH0TXD3
61	ETH0RXCLK	62	ETH0TXCLK
63	ETH0RXER	64	ETH0TXER
65	ETH0CRSDV	66	ETH0TXEN
67	ETH0RXDV	68	ETH0COL
69	ETH0RESET	70	ETH0LINK
71	CANXL0TX	72	CANXL1TX
73	CANXL0RX	74	CANXL1RX
75	CANXL2TX	76	CANXL3TX
77	CANXL2RX	78	CANXL3RX
79	ETH0_T1S_TX	80	ETH1_T1S_TX
81	ETH0_T1S_RX_MDC	82	ETH1_T1S_RX_MDC
83	ETH0_T1S_ED_MDIO	84	ETH1_T1S_ED_MDIO
85	DIGIO_0	86	DIGIO_1
87	DIGIO_2	88	DIGIO_3
89	DIGIO_4	90	DIGIO_5
91	DIGIO_6	92	DIGIO_7
93	DIGIO_8	94	DIGIO_9
95	DIGIO_10	96	DIGIO_11
97	DIGIO_12	98	DIGIO_13
99	DIGIO_14	100	DIGIO_15
101	–	102	–
103	MUX0	104	MUX1
105	MUX2	106	–
107	ADC0	108	ADC1
109	ADC2	110	ADC3
111	ADC4	112	ADC5
113	ADC6	114	ADC7
115	VDDIOF	116	VDDIOF
117	VSYS3V3	118	VSYS3V3
119	VSYS3V3	120	VSYS3V3

Table 5.1 Piggyback Board Connector CN1 pin assignment (cont'd)

Pin	Main board function	Pin	Main board function
121	GND	122	GND
123	GND	124	GND
125	GND	126	GND
127	GND	128	GND

Table 5.2 Piggyback Board Connector CN2 pin assignment

Pin	Main board function	Pin	Main board function
1	CAN2TX	2	CAN3TX
3	CAN2RX	4	CAN3RX
5	CAN4TX	6	CAN5TX
7	CAN4RX	8	CAN5RX
9	LIN2TX	10	LIN3TX
11	LIN2RX	12	LIN3RX
13	LIN4TX	14	LIN5TX
15	LIN4RX	16	LIN5RX
17	LIN6TX	18	LIN7TX
19	LIN6RX	20	LIN7RX
21	LIN8TX	22	LIN9TX
23	LIN8RX	24	LIN9RX
25	LIN10TX	26	LIN11TX
27	LIN10RX	28	LIN11RX
29	LIN12TX	30	LIN13TX
31	LIN12RX	32	LIN13RX
33	LIN14TX	34	LIN15TX
35	LIN14RX	36	LIN15RX
37	–	38	–
39	CAN12TX	40	CAN13TX
41	CAN12RX	42	CAN13RX
43	CAN14TX	44	CAN15TX
45	CAN14RX	46	CAN15RX
47	CAN6TX	48	CAN7TX
49	CAN6RX	50	CAN7RX
51	CAN8TX	52	CAN9TX
53	CAN8RX	54	CAN9RX
55	CAN10TX	56	CAN11TX
57	CAN10RX	58	CAN11RX
59	–	60	–

Table 5.2 Piggyback Board Connector CN2 pin assignment (cont'd)

Pin	Main board function	Pin	Main board function
61	LIN16TX	62	LIN17TX
63	LIN16RX	64	LIN17RX
65	LIN18TX	66	LIN19TX
67	LIN18RX	68	LIN19RX
69	LIN20TX	70	LIN21TX
71	LIN20RX	72	LIN21RX
73	LIN22TX	74	LIN23TX
75	LIN22RX	76	LIN23RX
77	–	78	–
79	SFMA0CLK	80	SFMA0SSL
81	SFMA0IO0	82	SFMA0IO1
83	SFMA0IO2	84	SFMA0IO3
85	–	86	–
87	MMCA0CLK	88	MMCA0CMD
89	MMCA0DAT0	90	MMCA0DAT1
91	MMCA0DAT2	92	MMCA0DAT3
93	MMCA0DAT4	94	MMCA0DAT5
95	MMCA0DAT6	96	MMCA0DAT7
97	–	98	–
99	ETH1MDIO	100	ETH1MDC
101	ETH1RXD0	102	ETH1TXD0
103	ETH1RXD1	104	ETH1TXD1
105	ETH1RXD2	106	ETH1TXD2
107	ETH1RXD3	108	ETH1TXD3
109	ETH1RXCLK	110	ETH1TXCLK
111	ETH1RXER	112	ETH1TXER
113	ETH1CRSDV	114	ETH1TXEN
115	ETH1RXDV	116	ETH1COL
117	ETH1RESET	118	ETH1LINK
119	–	120	–
121	GND	122	GND
123	GND	124	GND
125	GND	126	GND
127	GND	128	GND

Table 5.3 Piggyback Board Connector CN3 pin assignment (cont'd)

Pin	Main board function	Pin	Main board function
1	CSI0CS0	2	CSI0CLK
3	CSI0CS1	4	CSI0SI
5	CSI0CS2	6	CSI0SO
7	CSI0CS3	8	–
9	–	10	CSI1CS1
11	I2S0TXD	12	I2S1TXD
13	I2S0RXD	14	I2S1RXD
15	I2S0BCLK	16	I2S1BCLK
17	I2S0LRCLK	18	I2S1LRCLK
19	I2SMCLK	20	–
21	CSI1CS2	22	CSI1CS3
23	–	24	CSI1CS0
25	–	26	DIGIO_24
27	–	28	CSI1SO
29	CSI1CLK	30	CSI1SI
31	–	32	–
33	MOT0ADU	34	MOT1ADU
35	MOT0ADV	36	MOT1ADV
37	MOT0ADW	38	MOT1ADW
39	MOT0RDCS1	40	MOT1RDCS1
41	MOT0RDCS3	42	MOT1RDCS3
43	MOT0RDCS2	44	MOT1RDCS2
45	MOT0RDCS4	46	MOT1RDCS4
47	MOT0RDCCOM	48	MOT1RDCCOM
49	MOT0RDCRSO	50	MOT1RDCRSO
51	–	52	–
53	–	54	–
55	AD1_0	56	AD1_1
57	AD1_2	58	AD1_3
59	AD1_4	60	AD1_5
61	AD1_6	62	AD1_7
63	PWM0	64	PWM1
65	PWM2	66	PWM3
67	PWM4	68	PWM5
69	PWM6	70	PWM7
71	DIGIO_16	72	DIGIO_17
73	DIGIO_18	74	DIGIO_19
75	DIGIO_20	76	DIGIO_21

Table 5.3 Piggyback Board Connector CN3 pin assignment (cont'd)

Pin	Main board function	Pin	Main board function
77	DIGIO_22	78	DIGIO_23
79	ENC0	80	ENC1
81	MOT0ERR	82	MOT1ERR
83	MOT0U_P	84	MOT1U_P
85	MOT0U_N	86	MOT1U_N
87	MOT0V_P	88	MOT1V_P
89	MOT0V_N	90	MOT1V_N
91	MOT0W_P	92	MOT1W_P
93	MOT0W_N	94	MOT1W_N
95	–	96	–
97	–	98	–
99	–	100	ETH0_SO_P
101	GND	102	ETH0_SO_N
103	AD2_0	104	–
105	AD2_1	106	ETH0_SI_P
107	AD2_2	108	ETH0_SI_N
109	AD2_3	110	–
111	AD2_4	112	ETH1_SO_P
113	AD2_5	114	ETH1_SO_N
115	AD2_6	116	–
117	AD2_7	118	ETH1_SI_P
119	GND	120	ETH1_SI_N
121	GND	122	GND
123	GND	124	GND
125	GND	126	GND
127	GND	128	GND

5.2 LIN Interfaces

The main board provides 24 LIN interfaces using NXP TJA1021 LIN transceiver.

Each LIN channel can be switched on separately using the main board configurator.

The 24 LIN interfaces are grouped in 6 blocks (numbered 1 to 6) with 4 channels (named LA, LB, LC, and LD) each.

The main board configurator can enable a feedback line between channel LA and channel LB and/or channel LC and channel LD inside each LIN block.

Connector CN1_LA_1 (LIN0, channel LA in block 1) can also be used as UART output. This can be selected by the only jumper on this main board, jumper JP1. For details, please see 5.2.3 LIN0 / UART0 selection.

Chapter 5.2.1 shows the circuit diagram of the LIN circuits.

Chapter 5.2.2 lists all connectors for the LIN interfaces and shows their pin configuration.

5.2.1 LIN Circuit Diagram

The LIN circuit diagram is split into three levels. Figure 5.1 to Figure 5.4 show the different levels.

Figure 5.1 is the top level. It shows 6 LIN blocks, where each block includes 4 LIN channels.

Figure 5.2 is the second level. It shows the details of a 4 channel LIN block except for the transceiver details.

Figure 5.3 and Figure 5.4 are the third level. They show the details of the LIN transceiver circuit. From board version D019712_06_V02 onwards the power supply LEDs LED1Lx_y have been added.

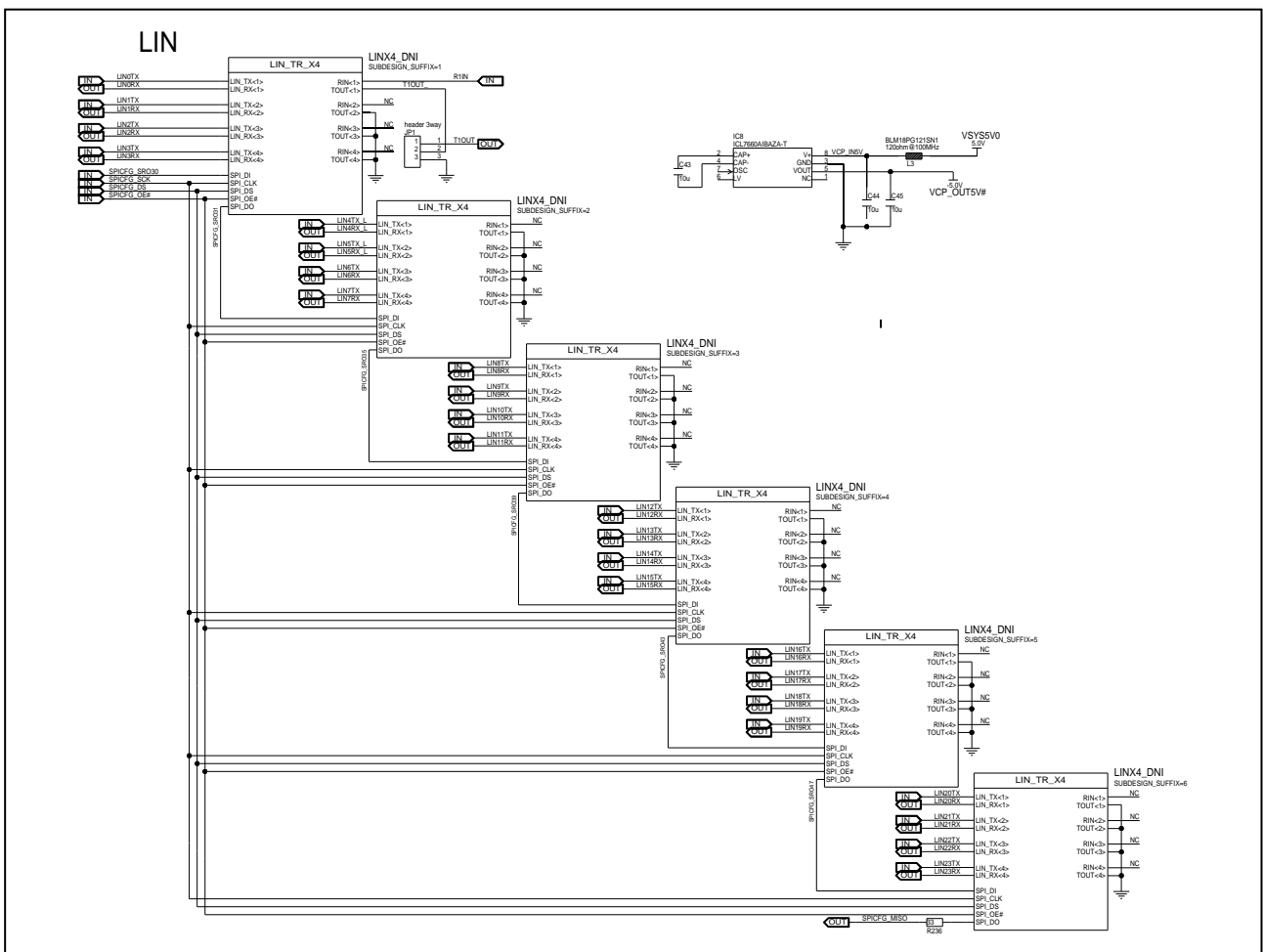

Figure 5.1 Circuit diagram LIN interfaces

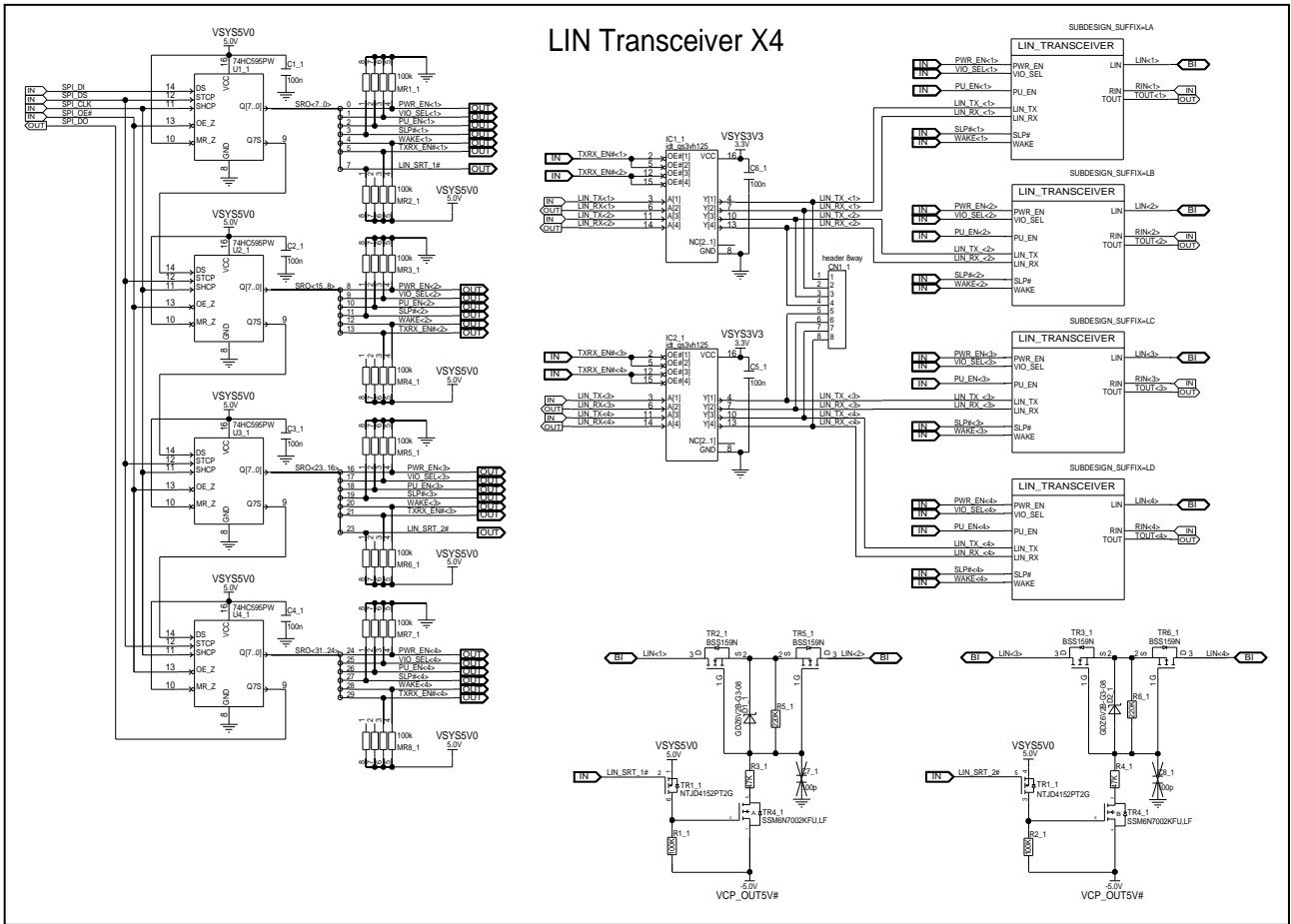

Figure 5.3 Circuit diagram LIN transceiver block X4

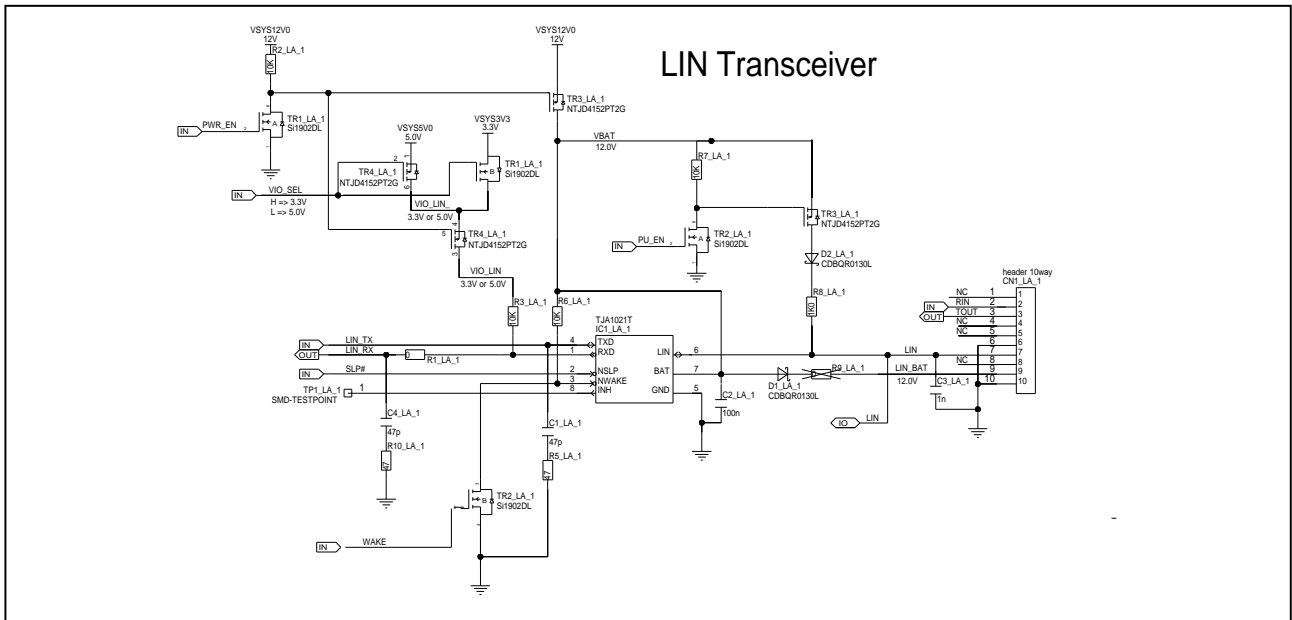

Figure 5.2 Circuit diagram LIN transceiver of board version D019712_06_V01

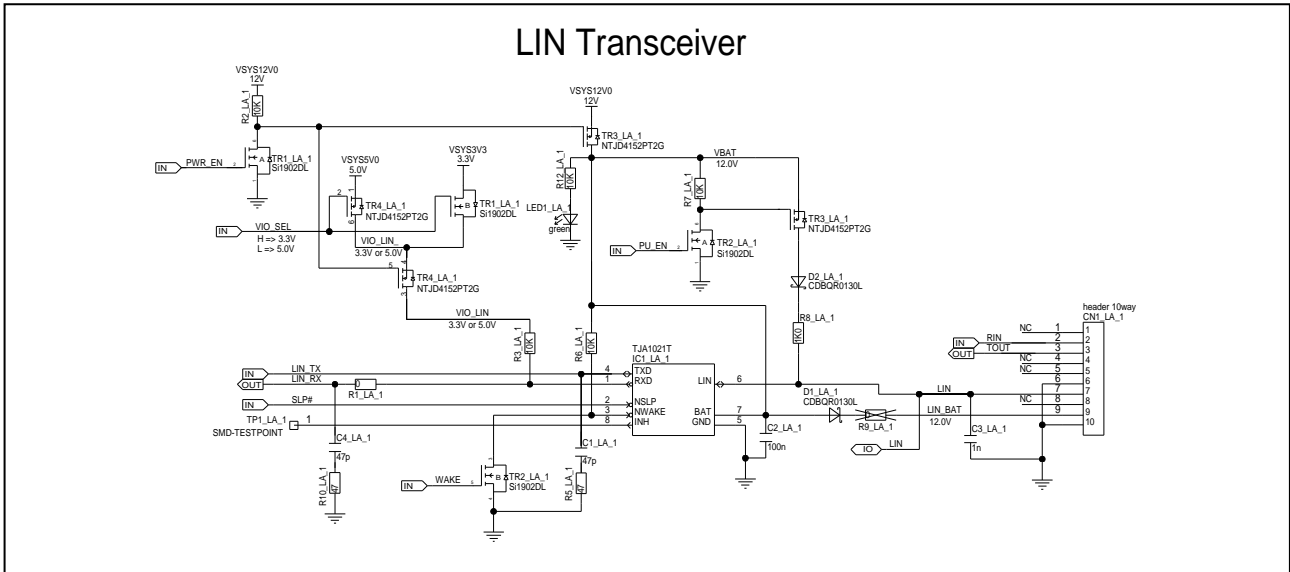

Figure 5.4 Circuit diagram LIN transceiver of board version D019712_06_V02 and later

5.2.2 LIN Interface Connectors

Each LIN interface has a separate connector. Table 5.4 shows which LIN interface uses which connector.

The pin configuration of each LIN interface connector is shown in Table 5.6.

In addition to the LIN interface specific connectors each LIN interface block of 4 channels has a separate connector which allows monitoring of the LIN signals before they enter the LIN transceiver. The pin configuration of these connectors is shown in Table 5.5.

Table 5.4 LIN interface LINn and 10-pin connector CN1_Lx_y correspondence

LINn	CN1_Lx_y	LINn	CN1_Lx_y	LINn	CN1_Lx_y	LINn	CN1_Lx_y
LIN0	CN1_LA_1	LIN1	CN1_LB_1	LIN2	CN1_LC_1	LIN3	CN1_LD_1
LIN4	CN1_LA_2	LIN5	CN1_LB_2	LIN6	CN1_LC_2	LIN7	CN1_LD_2
LIN8	CN1_LA_3	LIN9	CN1_LB_3	LIN10	CN1_LC_3	LIN11	CN1_LD_3
LIN12	CN1_LA_4	LIN13	CN1_LB_4	LIN14	CN1_LC_4	LIN15	CN1_LD_4
LIN16	CN1_LA_5	LIN17	CN1_LB_5	LIN18	CN1_LC_5	LIN19	CN1_LD_5
LIN20	CN1_LA_6	LIN21	CN1_LB_6	LIN22	CN1_LC_6	LIN23	CN1_LD_6

Table 5.5 Monitor connectors for LIN signals

Pin	CN1_1	CN1_2	CN1_3	CN1_4	CN1_5	CN1_6
1	LIN0_TX	LIN4_TX	LIN8_TX	LIN12_TX	LIN16_TX	LIN20_TX
2	LIN0_RX	LIN4_RX	LIN8_RX	LIN12_RX	LIN16_RX	LIN20_RX
3	LIN1_TX	LIN5_TX	LIN9_TX	LIN13_TX	LIN17_TX	LIN21_TX
4	LIN1_RX	LIN5_RX	LIN9_RX	LIN13_RX	LIN17_RX	LIN21_RX
5	LIN2_TX	LIN6_TX	LIN10_TX	LIN14_TX	LIN18_TX	LIN22_TX
6	LIN2_RX	LIN6_RX	LIN10_RX	LIN14_RX	LIN18_RX	LIN22_RX
7	LIN3_TX	LIN7_TX	LIN11_TX	LIN15_TX	LIN19_TX	LIN23_TX
8	LIN3_RX	LIN7_RX	LIN11_RX	LIN15_RX	LIN19_RX	LIN23_RX

Table 5.6 LINn interface on 10-pin connectors CN1_Lx_y

CN1_LA_1 for LIN0 (UART0*)			CN1_Lx_y (LINn) (see Table 5.4)	
Pin	Function in LIN0 mode (JP1[2-3])	Function in UART0 mode (JP1[2-1])	Pin	Function
1	–	–	1	–
2	(R1IN*)	R1IN	2	–
3	GND	TOUT	3	GND
4	–	–	4	–
5	–	–	5	–
6	GND	GND	6	GND
7	LIN0	(LIN0*)	7	LINn
8	–	–	8	–
9	LIN0_BAT	(LIN0_BAT*)	9	LINn_BAT
10	GND	GND	10	GND

Note: * These signals are always connected to the related pin but may be irrelevant in the respective mode.

5.2.3 LIN0 / UART0 selection

The connector CN1_LA_1 can be used as LIN0 or UART0 interface. The selection is done using jumper JP1.

- JP1[1-2]: CN1_LA_1 is used as UART0 connector
- JP1[2-3]: CN1_LA_1 is used as LIN0 connector

5.3 CAN Interfaces

The main board provides 16 CAN interfaces using Microchip ATA6561 CAN transceiver.

Each CAN channel can be switched on separately using the main board configurator.

The 16 CAN interfaces are grouped in 4 blocks (named C1 to C4) with 4 channels (named CA, CB, CC and CD) each.

The main board configurator can enable a loopback connection between channel CA and channel CB and/or channel CC and channel CD inside each CAN block.

In the board configuration it is also possible to control the STB signal and to enable a bus termination resistor for each CAN channel separately.

Chapter 5.3.1 shows the circuit diagram of the CAN circuits.

Chapter 0 lists all connectors for the CAN interfaces and shows their pin configuration.

5.3.1 CAN Circuit Diagram

Figure 5.5 to Figure 5.8 show the CAN circuit diagram. The circuit diagram is split into three levels.

Figure 5.5 is the top level. It shows 4 CAN blocks, where each block includes 4 CAN channels.

Figure 5.6 is the second level. It shows the details of a 4 channel CAN block except for the transceiver details.

Figure 5.7 and Figure 5.8 are the third level. They show the details of the CAN transceiver circuit.

As with the LIN interface, from board version D019712_06_V02 onwards a power supply LEDs LED1Cx_y have been added to the transceiver circuit.

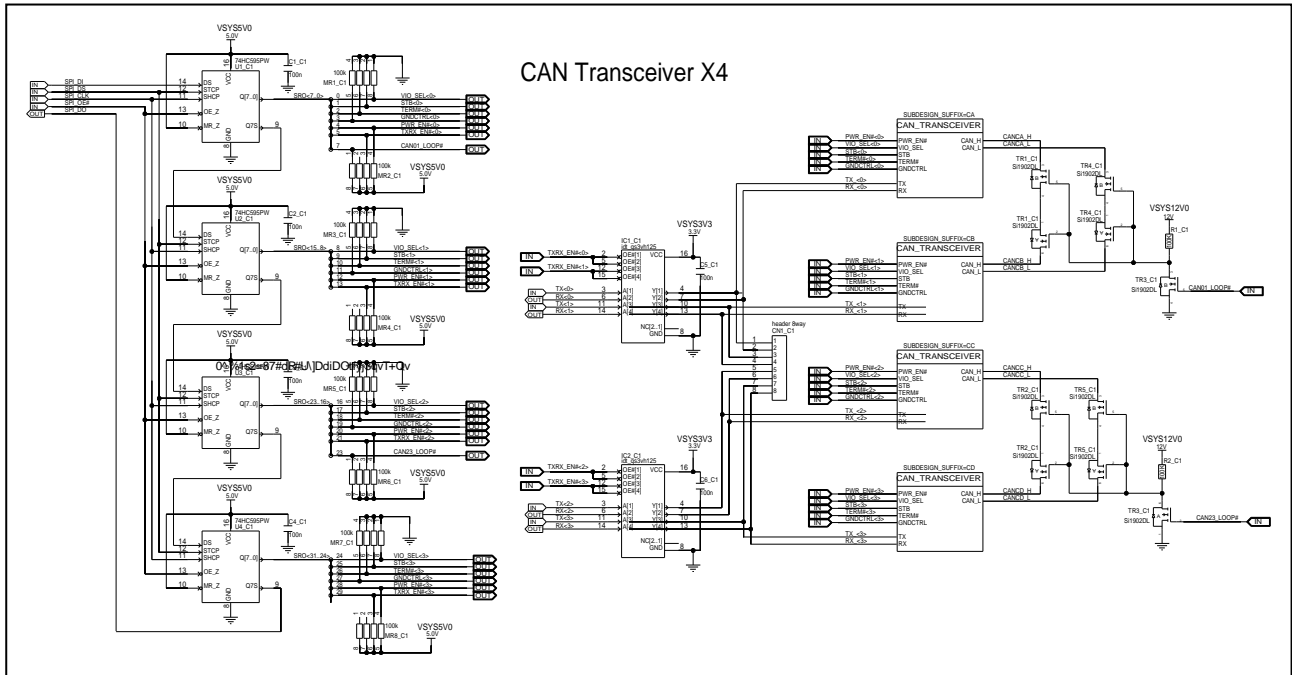

Figure 5.5 Circuit diagram CAN interfaces

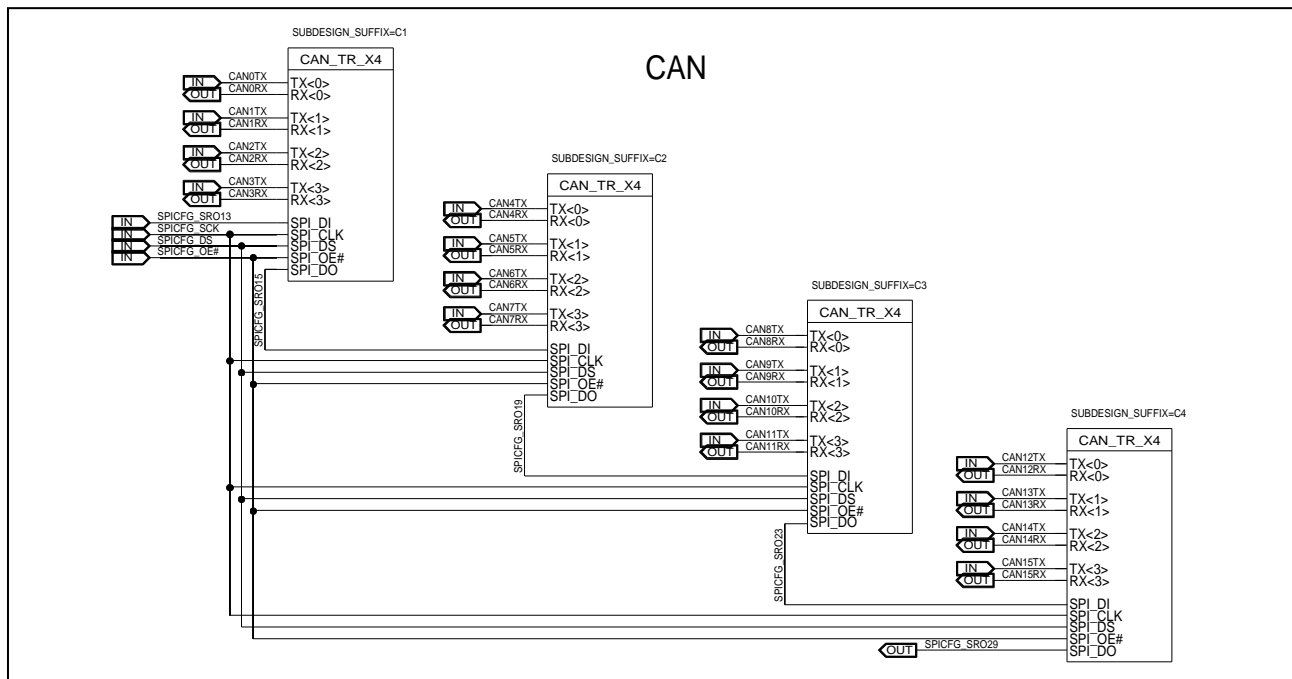

Figure 5.6 Circuit diagram CAN transceiver block X4

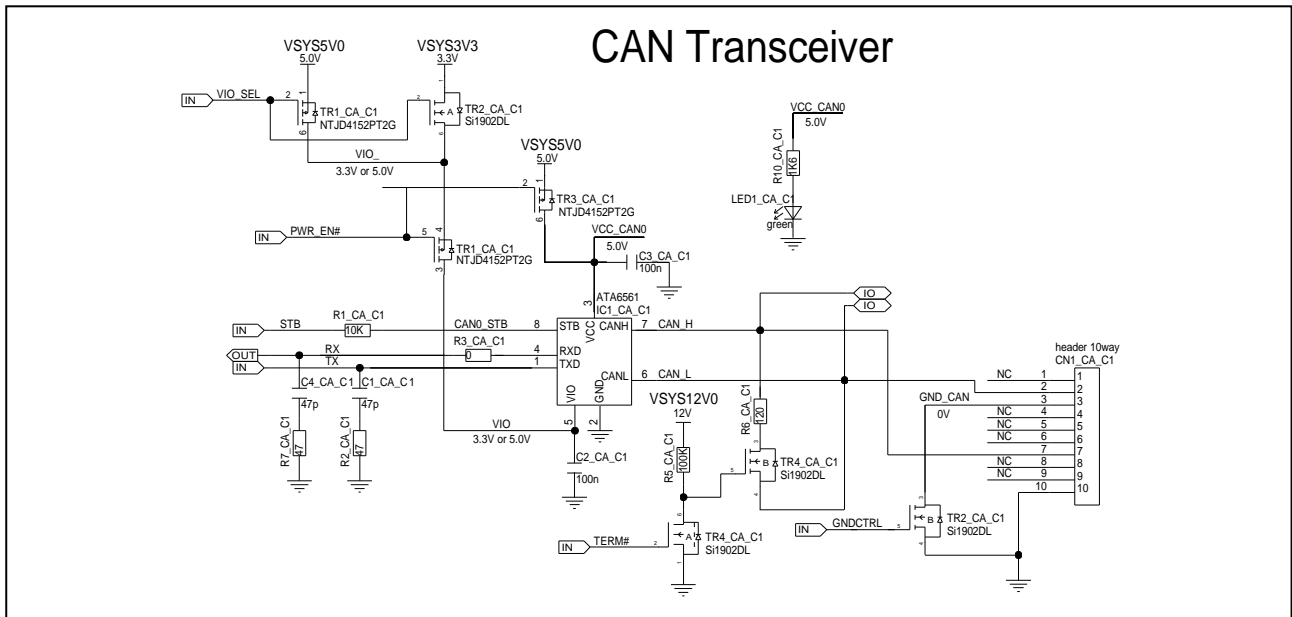

Figure 5.8 Circuit diagram CAN transceiver of board version D019712_06_V01

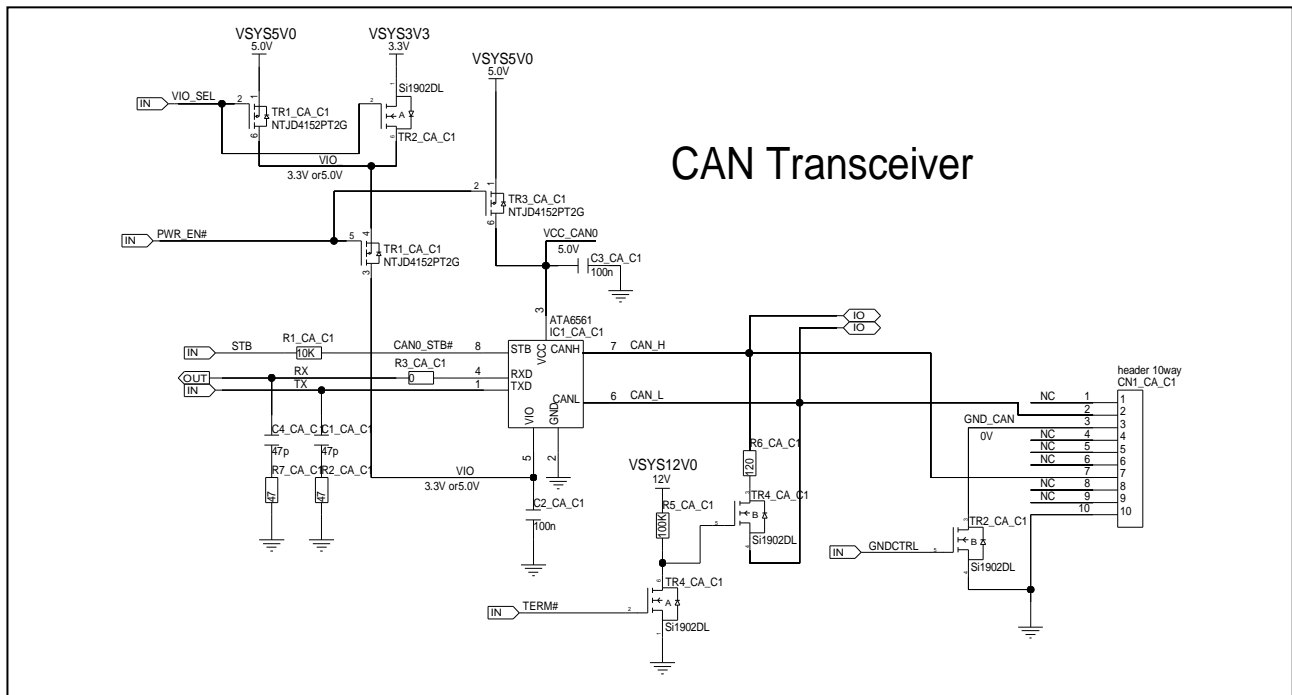

Figure 5.7 Circuit diagram CAN transceiver of board version D019712_06_V02 and later

5.3.2 CAN Interface Connectors

Each CAN interface has a separate connector. *Table 5.7* shows which CAN interface uses which connector. The pin configuration of each CAN interface connector is shown in *Table 5.8*.

In addition to the CAN interface specific connectors each CAN interface block of 4 channels has a separate connector which allows monitoring of the CAN signals before they enter the CAN transceiver. The pin configuration of these connectors is shown in *Table 5.9*.

Table 5.7 CAN interface CANn and connector CNm correspondence

CANn	CN1_Cx_Cy	CANn	CN1_Cx_Cy	CANn	CN1_Cx_Cy	CANn	CN1_Cx_Cy
CAN0	CN1_CA_C1	CAN1	CN1_CB_C1	CAN2	CN1_CC_C1	CAN3	CN1_CD_C1
CAN4	CN1_CA_C2	CAN5	CN1_CB_C2	CAN6	CN1_CC_C2	CAN7	CN1_CD_C2
CAN8	CN1_CA_C3	CAN9	CN1_CB_C3	CAN10	CN1_CC_C3	CAN11	CN1_CD_C3
CAN12	CN1_CA_C4	CAN13	CN1_CB_C4	CAN14	CN1_CC_C4	CAN15	CN1_CD_C4

Table 5.8 CANn interface on 10-pin connectors CN1_Cx_Cy

Pin	Voltage	Pin	Voltage
1	–	6	–
2	CANnL	7	CANnH
3	–/GND_CAN*	8	–
4	–	9	–
5	–	10	GND

Note: * Enabled in the board configuration settings

Table 5.9 Monitor connectors for CAN signals

Pin	CN1_C1	CN1_C2	CN1_C3	Cn1_C4
1	CAN0TX	CAN4TX	CAN8TX	CAN12TX
2	CAN0RX	CAN4RX	CAN8RX	CAN12RX
3	CAN1TX	CAN5TX	CAN9TX	CAN13TX
4	CAN1RX	CAN5RX	CAN9RX	CAN13RX
5	CAN2TX	CAN6TX	CAN10TX	CAN14TX
6	CAN2RX	CAN6RX	CAN10RX	CAN14RX
7	CAN3TX	CAN7TX	CAN11TX	CAN15TX
8	CAN3RX	CAN7RX	CAN11RX	CAN15RX

5.4 CAN XL Modules

The main board has two connectors for external CAN XL modules. Each of the CAN XL modules can have 2 CAN channels.

The connectors for the CAN XL modules are activated by the main board configurator.

Renesas prepares an extension board supporting CAN XL functionality named Y-COMMON-CANXL-NN.

Figure 5.9 shows in the upper part the circuit diagram for CAN XL channels 0 and 1 and in the lower part the circuit diagram for CAN XL channels 2 and 3.

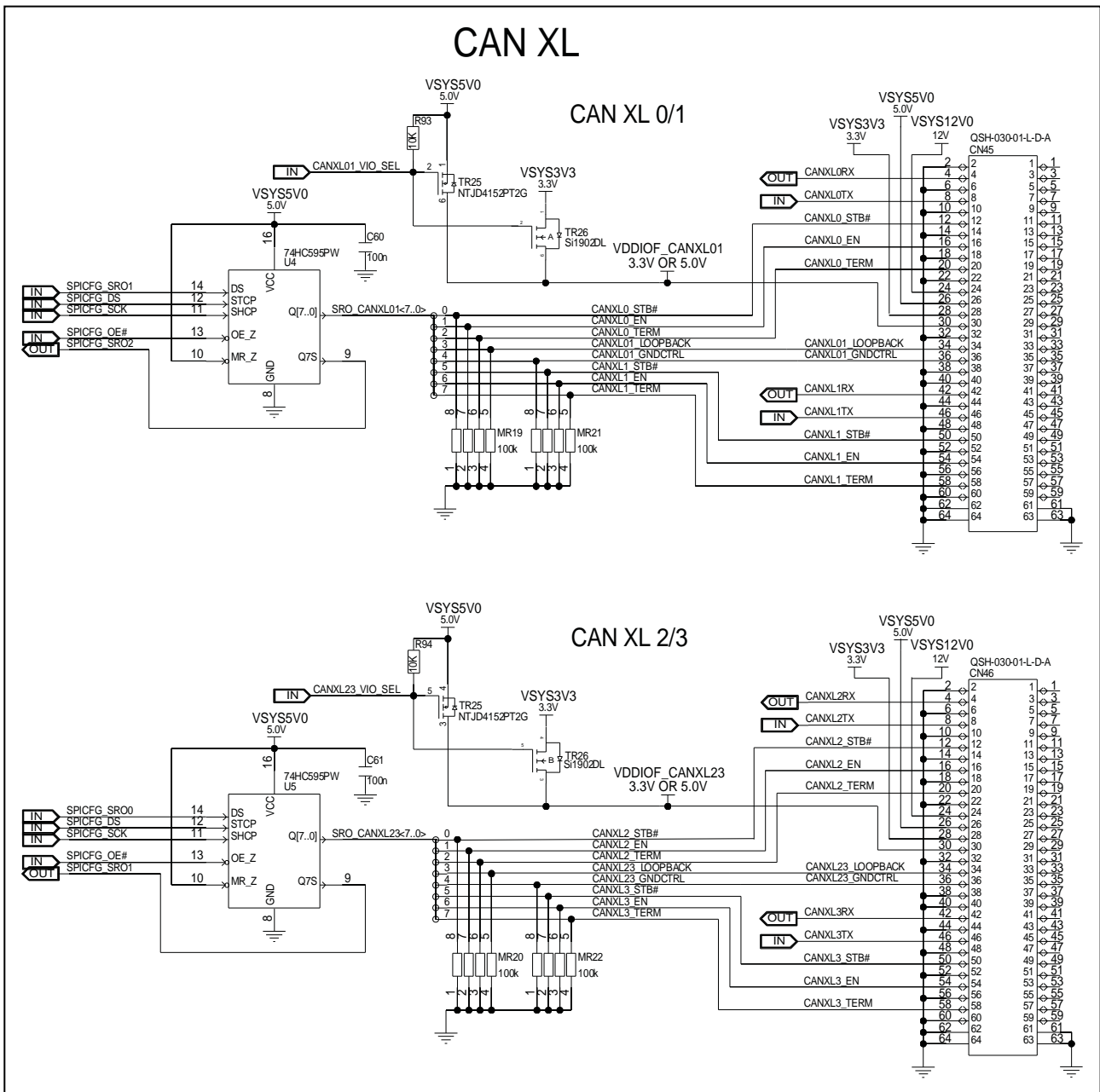

Figure 5.9 CAN XL connector circuit diagram

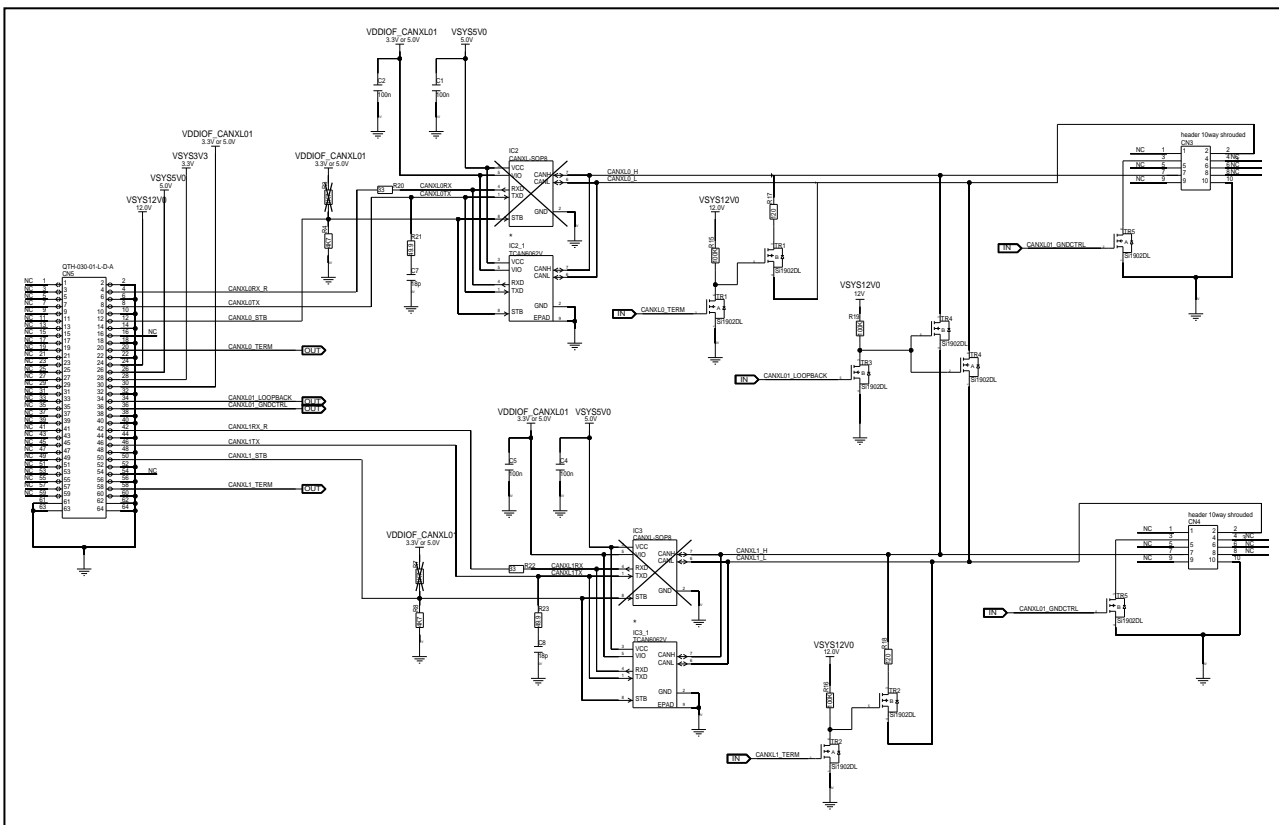

Figure 5.11 Y-COMMON-CANXL-TCAN6062V board circuit diagram

Figure 5.14 shows the physical dimensions of this board.

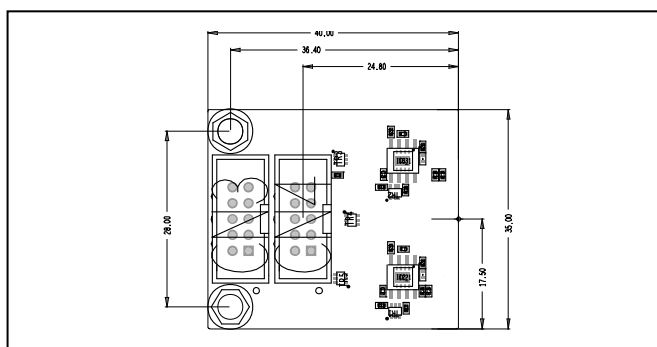

Figure 5.12 Y-COMMON-CANXL-NN dimensions

5.5 FlexRay Interfaces

The main board provides 2 FlexRay interfaces using NXP TJA1080ATS FlexRay transceiver.

The FlexRay interfaces can be enabled and configured separately using the main board configurator.

The main board configurator also controls the bus termination circuit with the FLX0_TERM# and FLX1_TERM# signals and the loop between FLEXRAY0 and FLEXRAY1 using the FLX01_LOOP# signal.

5.5.1 Circuit Diagram

Figure 5.14 shows the connection of the main board configurator to the FlexRay circuit on board revision D019712_06_V01 and D019712_06_V02.

Figure 5.15 shows the connection of the main board configurator to the FlexRay circuit on board revision D019712_06_V03 and later.

Figure 5.16 shows the circuit diagrams of the FlexRay interfaces on board revision D019712_06_V01.

Figure 5.17 shows the circuit diagrams of the FlexRay interfaces on board revisions D019712_06_V02.

From board version D019712_06_V02 onwards the power supply LEDs LED25 and LED26 have been added.

Figure 5.18 shows the circuit diagrams of the FlexRay interfaces on board revisions D019712_06_V03.

Figure 5.19 shows the circuit diagrams of the FlexRay interfaces on board revisions D019712_06_V04 and later.

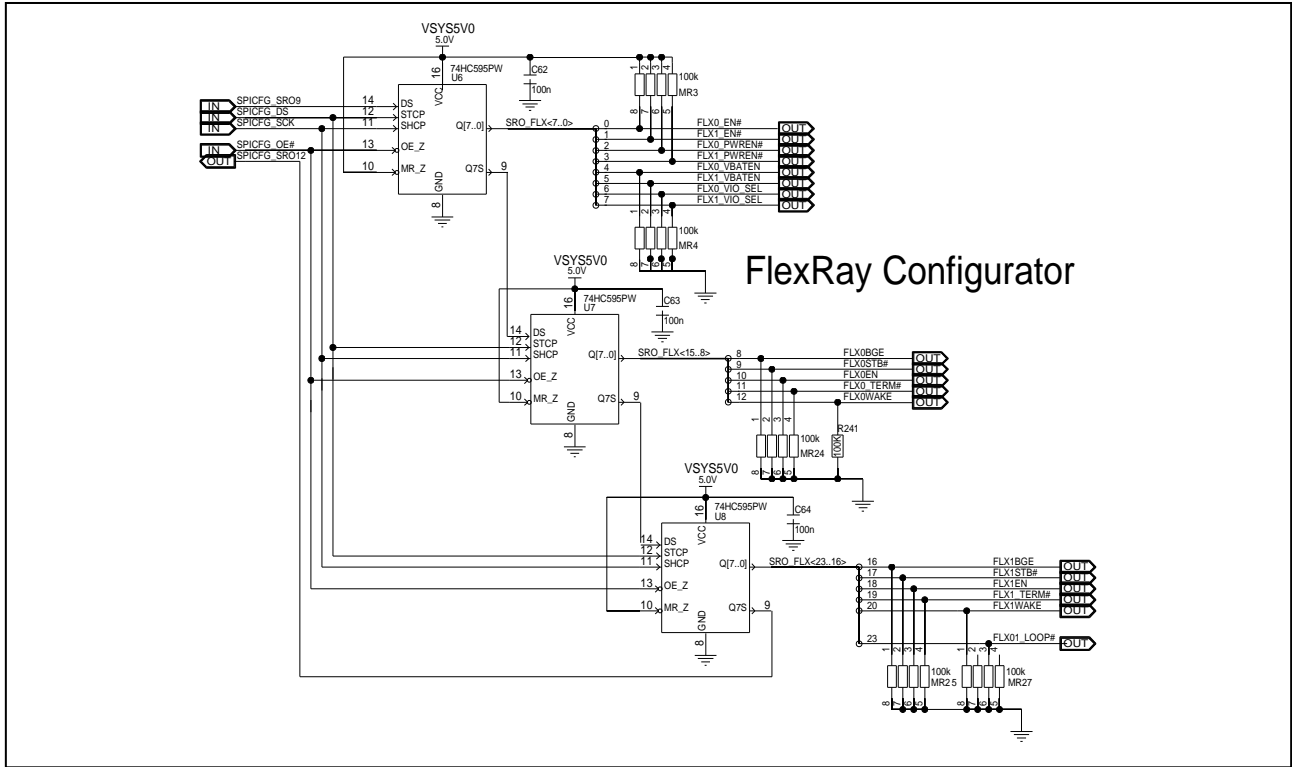

Figure 5.14 FlexRay configurator circuit diagram of board version D019712_06_V01 and D019712_06_V02

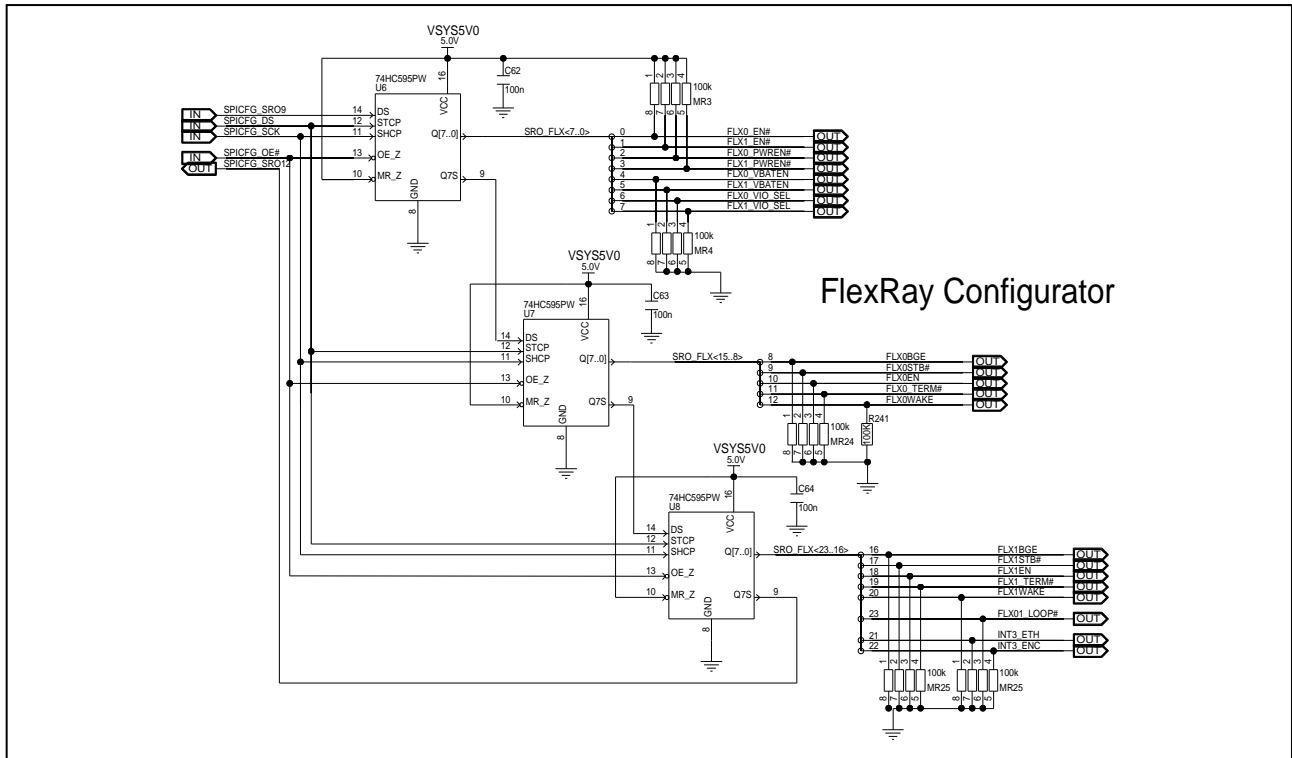

Figure 5.13 FlexRay configurator circuit diagram of board version D019712_06_V03 and later

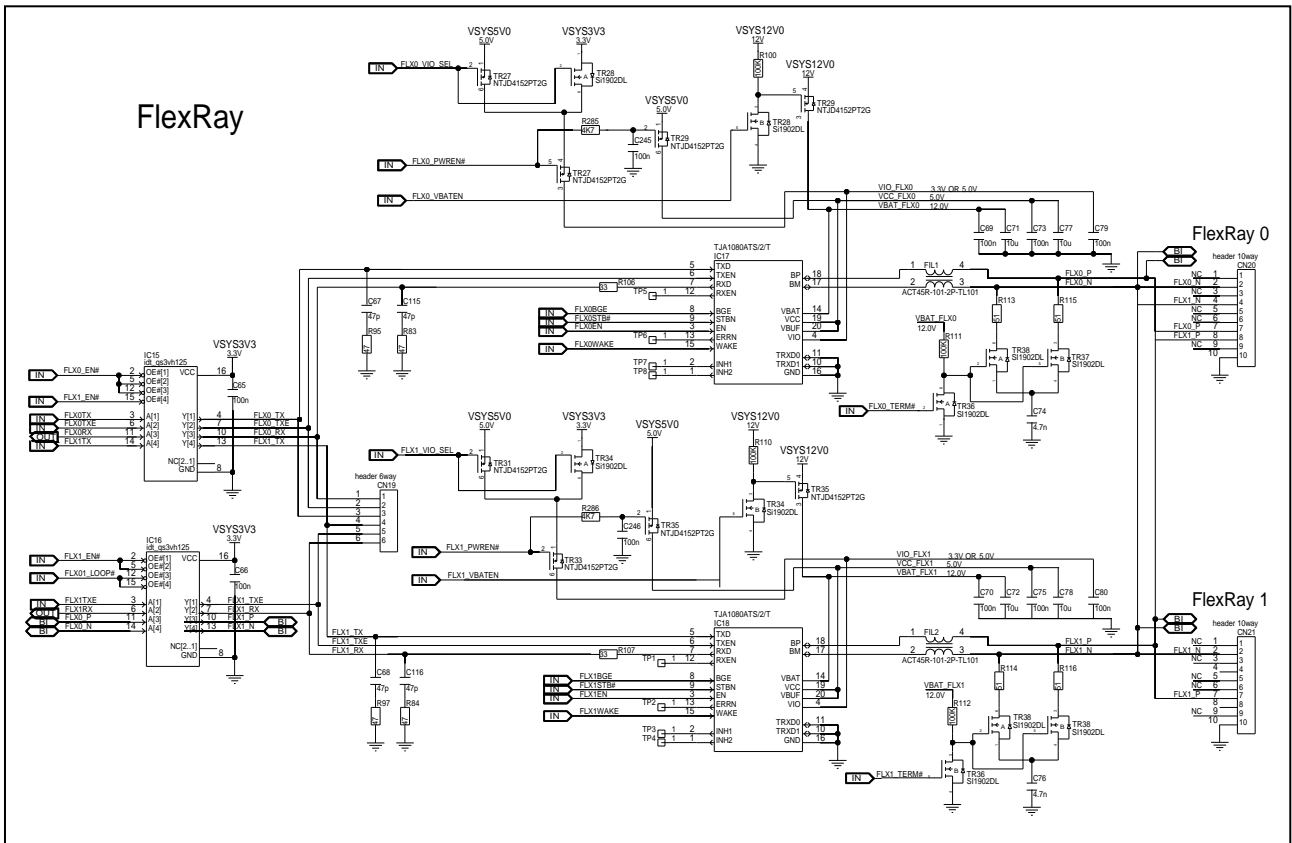

Figure 5.15 FlexRay interface circuit diagram of board version D019712_06_V01

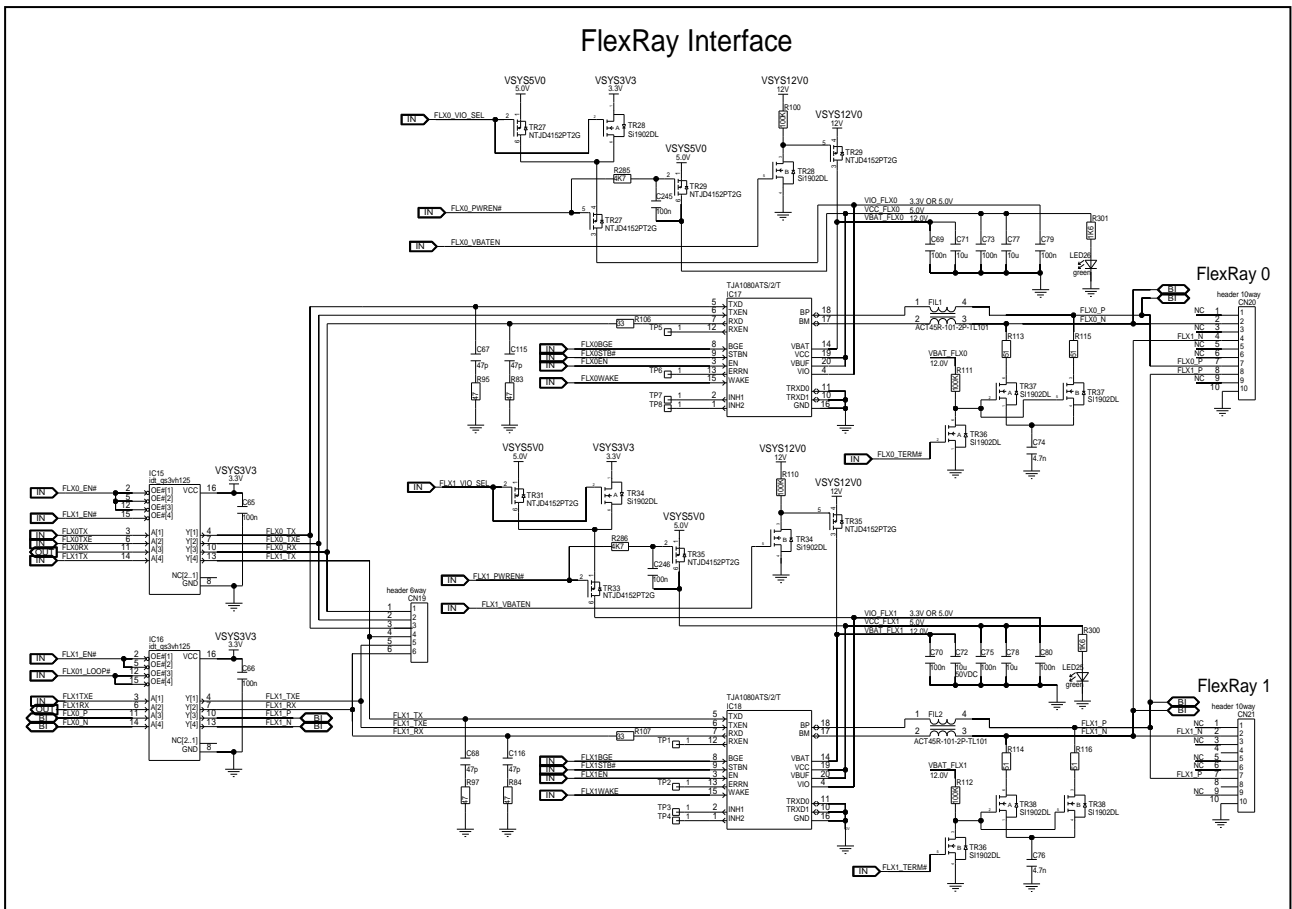

Figure 5.16 FlexRay interface circuit diagram of board version D019712_06_V02

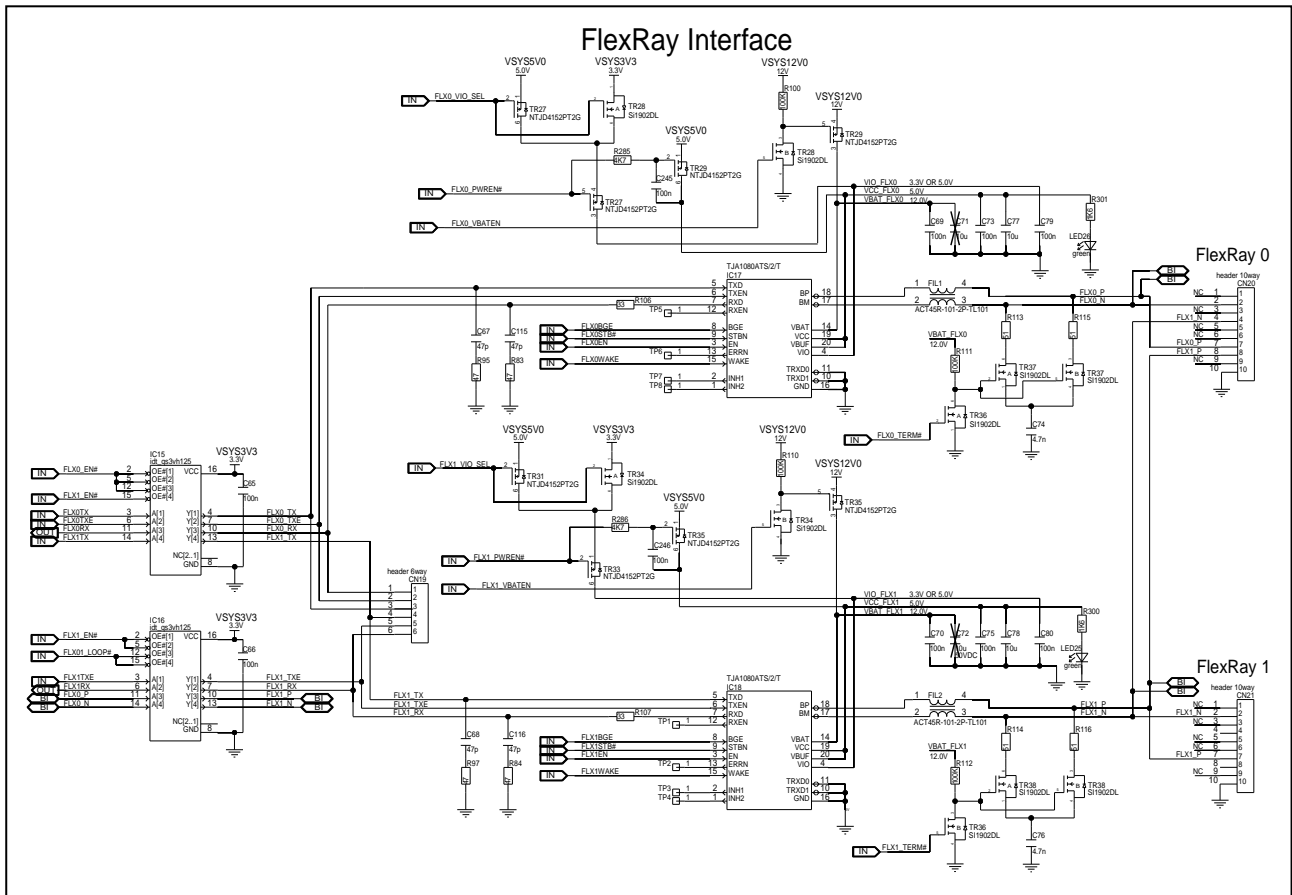

Figure 5.17 FlexRay interface circuit diagram of board version D019712_06_V03

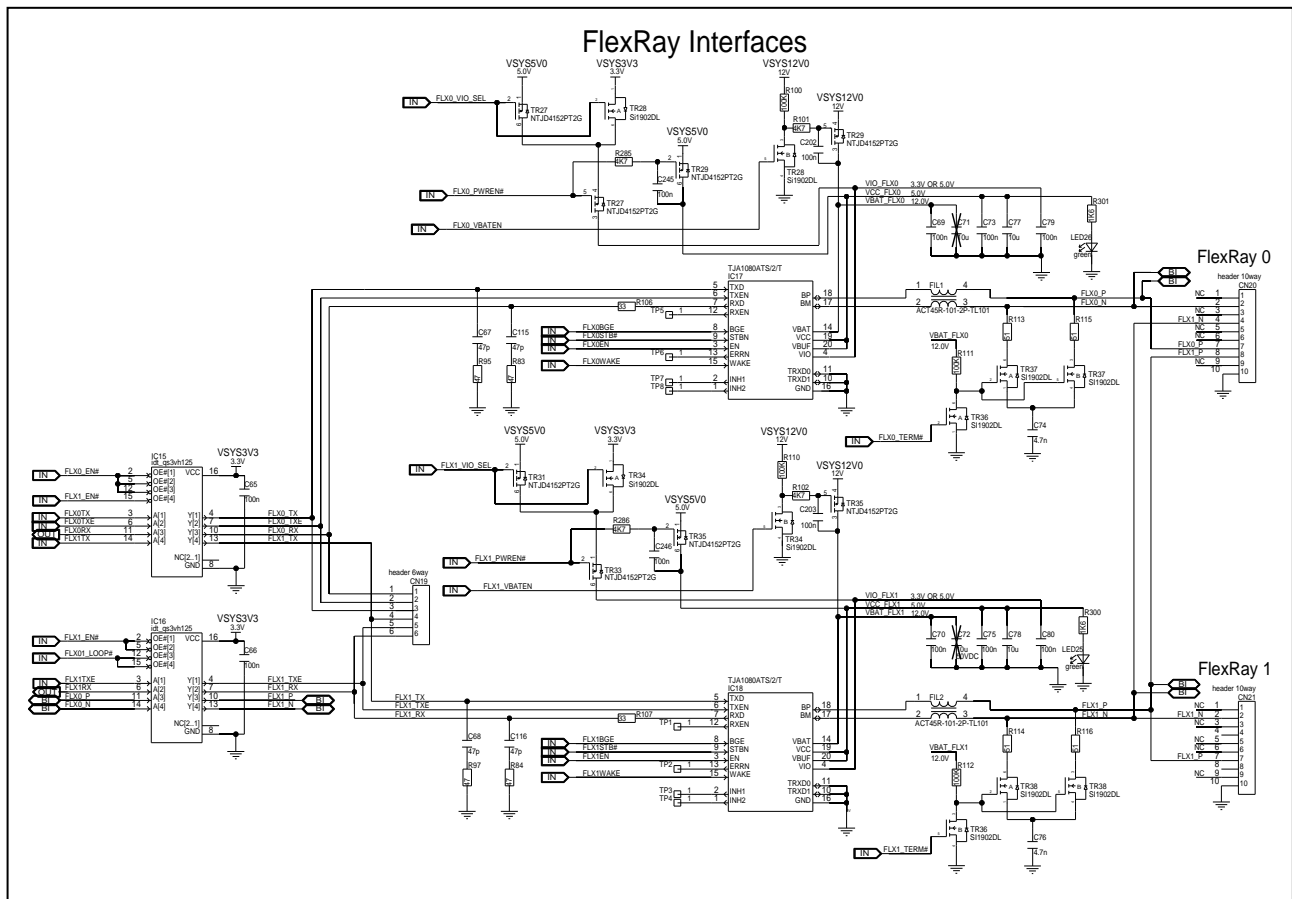

Figure 5.18 FlexRay interface circuit diagram of board version D019712_06_V04 and later

5.5.2 FlexRay Connectors

Connections to the FlexRay interfaces are provided on connectors CN20 and CN21. Table 5.10 shows the pin configuration of these connectors.

Table 5.10 FlexRay transceiver signal connectors

CN20	FlexRay Signal	CN21	FlexRay Signal
1	NC	1	NC
2	FLX0_N	2	FLX_1N
3	NC	3	NC
4	FLX1_N	4	NC
5	NC	5	NC
6	NC	6	NC
7	FLX0_P	7	FLX1_P
8	FLX1_P	8	NC
9	NC	9	NC
10	GND	10	GND

Like the LIN and CAN interfaces described before, also the FlexRay circuit includes a connector to monitor the interface signals before they are fed to the FlexRay transceivers. The monitor signals are provided in connector CN19. Table 5.11 shows the pin configuration of CN19.

Table 5.11 Monitor connector CN19 for FlexRay signals

Pin	CN19
1	FLX0_RX
2	FLX0_TXE
3	FLX0_TX
4	FLX1_TX
5	FLX1_TXE
6	FLX1_RX

5.6 Ethernet Modules

The main board has three connectors for Ethernet modules. Two connectors support MII/SGMII. The third connector supports two channels 10BASE-T1S.

5.6.1 Ethernet Modules Supporting MII/SGMII

The main board provides two connectors for MII/SGMII Ethernet modules. The list of applicable Ethernet modules is shown in *Table 5.12 Available Ethernet Modules*. The extension boards must be ordered separately. Please refer to chapter 1.5 *Extension Boards* for details.

Table 5.12 Available Ethernet Modules

Module Name	Interface	Ethernet PHY	Connection
Y-COMMON-100BASE-TX-LAN8700 (former Y-RH850-100BASE-TX-LAN8700)	MII	Microchip LAN8700	100BASE-TX 10BASE-T
Y-COMMON-1000BASE-T1-88Q2112 (former Y-RH850-1000BASE-T1-88Q2112)	SGMII	Marvell 88Q2112	100/1000BASE-T1

5.6.1.1 Circuit Diagram

Figure 5.20, Figure 5.21 and Figure 5.22 show the pin assignment on the connectors for Ethernet modules supporting MII and SGMII on different main board revisions.

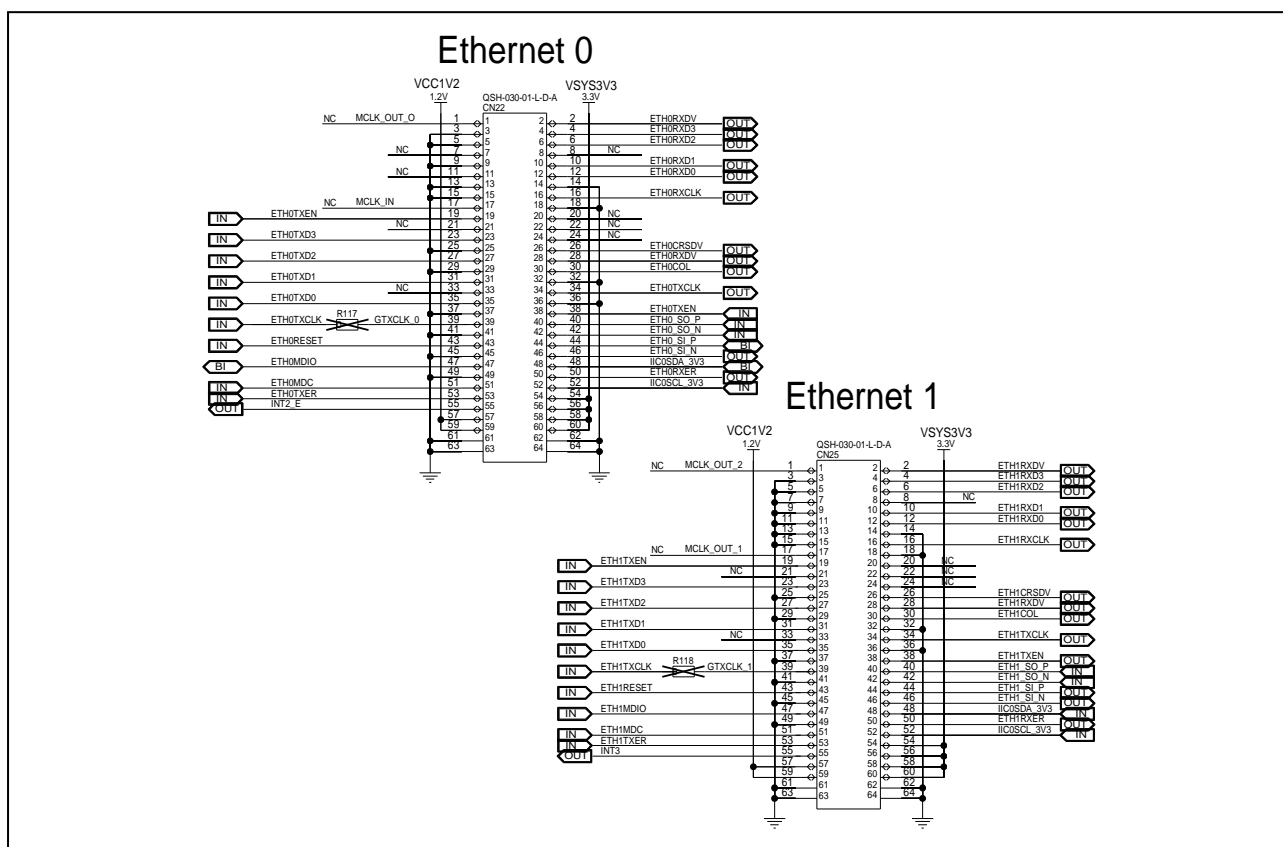

Figure 5.19 Ethernet module connector circuit for MII/SGMII compliant Ethernet modules of board version D019712_06_V01

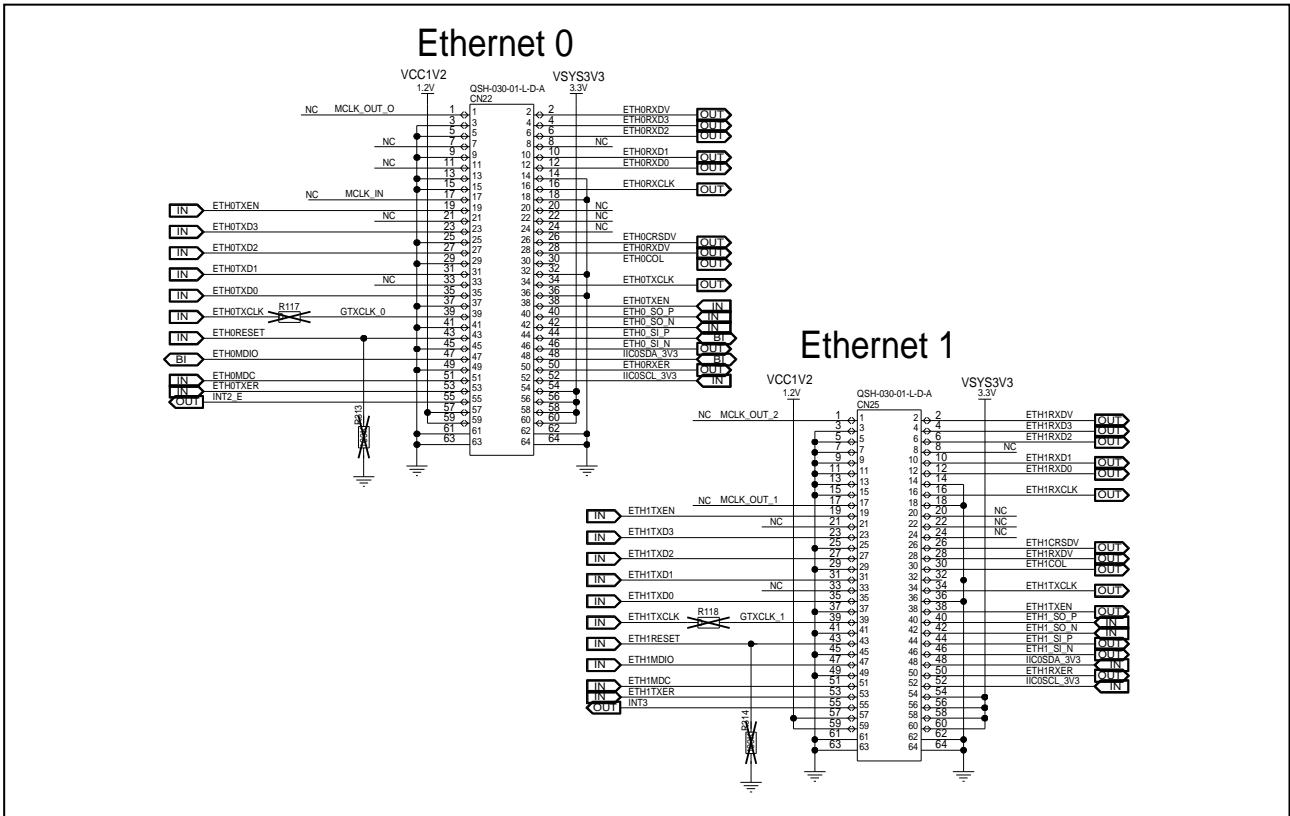

Figure 5.20 Ethernet module connector circuit for MII/SGMII compliant Ethernet modules of board version D019712_06_V02

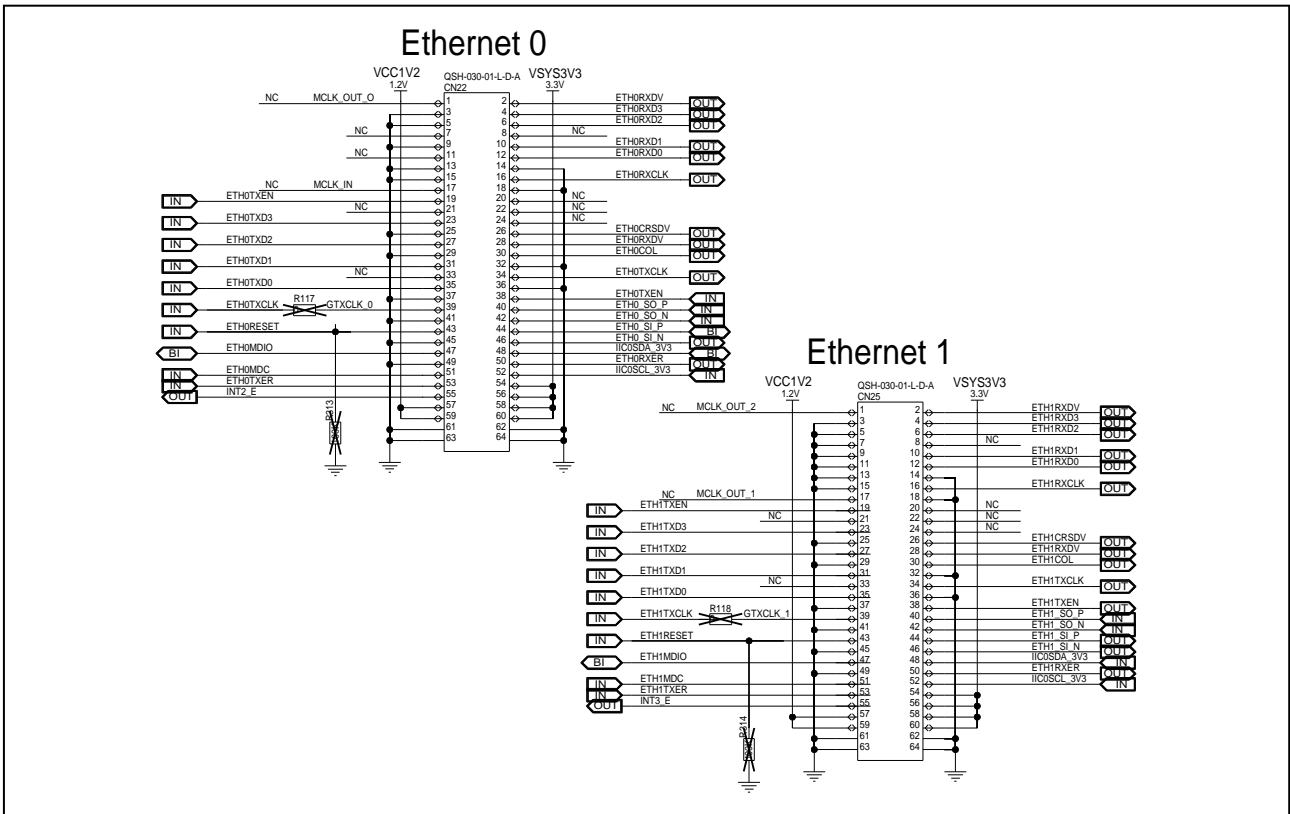

Figure 5.21 Ethernet module connector circuit for MII/SGMII compliant Ethernet modules of board version D019712_06_V03 and later

5.6.1.2 Pin Assignments of MII/SGMII Ethernet Connectors

Table 5.13 Ethernet PHY (MII/SGMII) connector CN22 pin assignment

Pin	Function	Pin	Function
1	– (MCLK_OUT_0*)	2	ETH0RXDV
3	GND	4	ETH0RXD3
5	GND	6	ETH0RXD2
7	–	8	–
9	GND	10	ETH0RXD1
11	–	12	ETH0RXD0
13	GND	14	GND
15	GND	16	ETH0RXCLK
17	– (MCLK_IN*)	18	GND
19	ETH0TXEN	20	–
21	–	22	–
23	ETH0TXD3	24	–
25	GND	26	ETH0CRSDV
27	ETH0TXD2	28	ETH0RXDV
29	GND	30	ETH0COL
31	ETH0TXD1	32	GND
33	–	34	ETH0TXCLK
35	ETH0TXD0	36	GND
37	GND	38	ETH0TXEN
39	– (ETH0TXCLK can be connected if R117 is assembled) (GTXCLK_0*)	40	ETH0_SO_P
41	GND	42	ETH0_SO_N
43	ETH0RESET	44	ETH0_SI_P
45	GND	46	ETH0_SI_N
47	ETH0MDIO	48	IIC0SDA_3V3
49	GND	50	ETH0RXER
51	ETH0MDC	52	IIC0SCL_3V3
53	ETH0TXER	54	VSYS3V3
55	INT2_E	56	VSYS3V3
57	VCC1V2	58	VSYS3V3
59	VCC1V2	60	VSYS3V3
61	GND	62	GND
63	GND	64	GND

Note: * These MII signals are not connected on the main board.

Table 5.14 Ethernet PHY (MII/SGMII) connector CN25 pin assignment

Pin	Function	Pin	Function
1	– (MCLK_OUT_2*)	2	ETH1RXDV
3	GND	4	ETH1RXD3
5	GND	6	ETH1RXD2
7	GND	8	–
9	GND	10	ETH1RXD1
11	GND	12	ETH1RXD0
13	GND	14	GND
15	GND	16	ETH1RXCLK
17	– (MCLK_OUT_1*)	18	GND
19	ETH1TXEN	20	–
21	–	22	–
23	ETH1TXD3	24	–
25	GND	26	ETH1CRSDV
27	ETH1TXD2	28	ETH1RXDV
29	GND	30	ETH1COL
31	ETH1TXD1	32	GND
33	–	34	ETH1TXCLK
35	ETH1TXD0	36	GND
37	GND	38	ETH1TXEN
39	– (ETH1TXCLK can be connected if R118 is assembled) (GTXCLK_1*)	40	ETH1_SO_P
41	GND	42	ETH1_SO_N
43	ETH1RESET	44	ETH1_SI_P
45	GND	46	ETH1_SI_N
47	ETH1MDIO	48	IIC0SDA_3V3
49	GND	50	ETH1RXER
51	ETH1MDC	52	IIC0SCL_3V3
53	ETH1TXER	54	VSYS3V3
55	INT3	56	VSYS3V3
57	VCC1V2	58	VSYS3V3
59	VCC1V2	60	VSYS3V3
61	GND	62	GND
63	GND	64	GND

Note: * These MII signals are not connected on the main board.

5.6.1.3 Renesas Ethernet Board Y-COMMON-100BASE-TX-LAN8700

Figure 5.23 shows the circuit diagram of the Ethernet board Y-COMMON-100BASE-TX-LAN8700. The base address of the Microchip PHY is 0x001F.

Note

The former name of this extension board was Y-RH850-100BASE-TX-LAN8700. Please check the piggyback board schematic carefully to ensure that on the piggyback board all necessary signals are connected from processor to the main board connector.

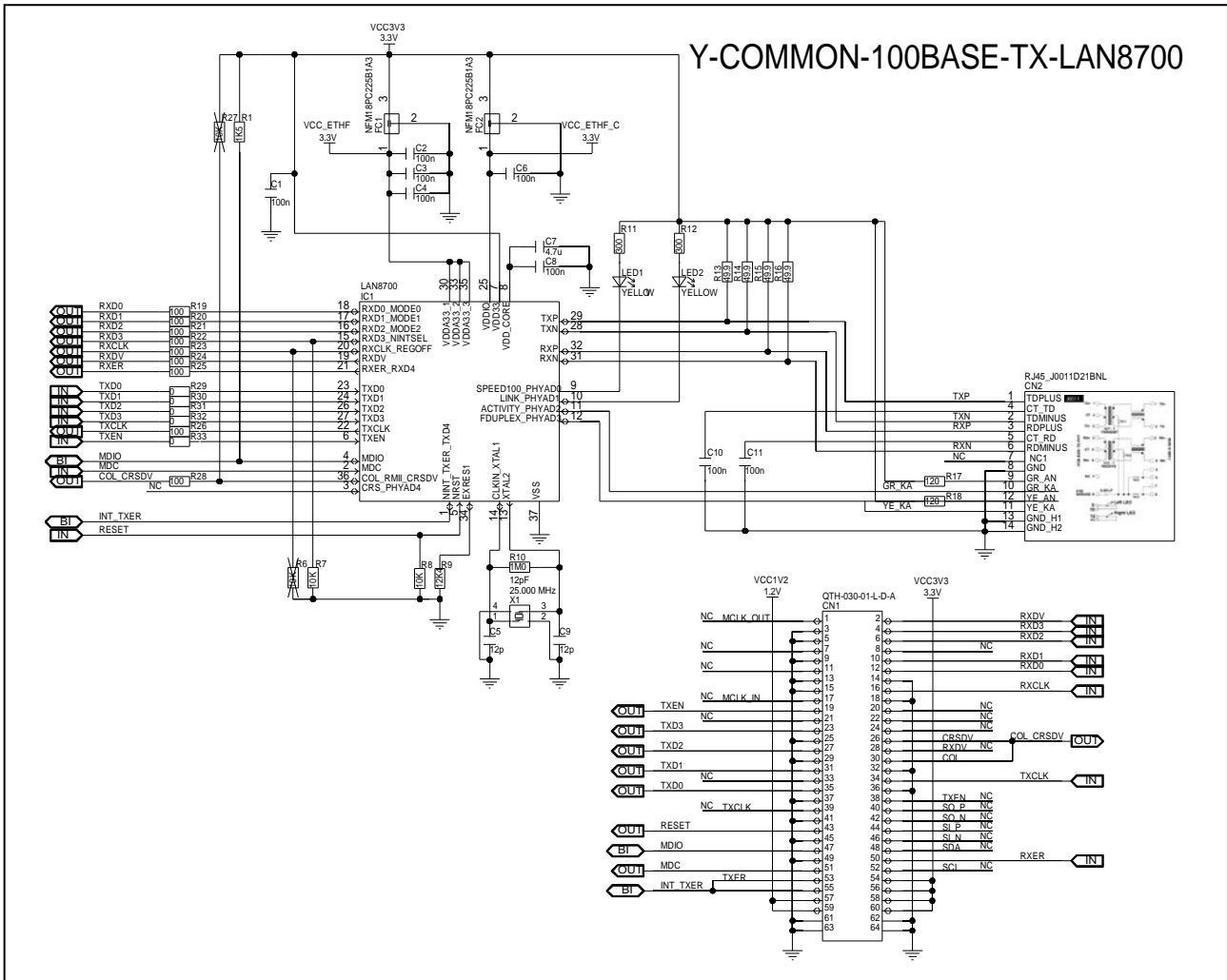
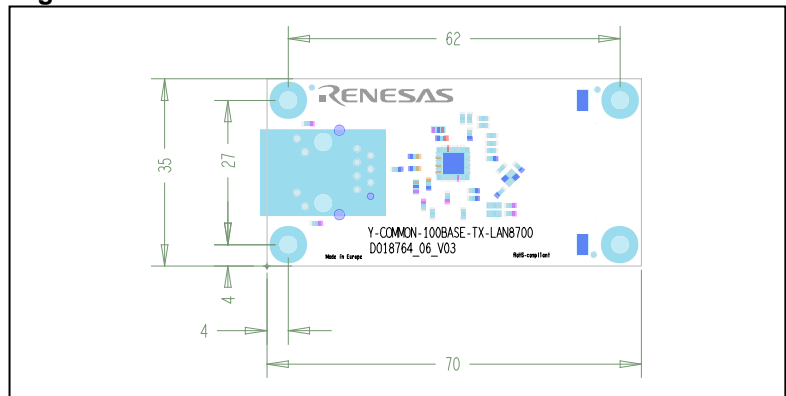

Figure 5.22 Circuit diagram of Renesas Ethernet board Y-COMMON-100BASE-TX-LAN8700
 Figure 5.23 Y-COMMON-100BASE-TX-LAN8700 dimensions

Figure 5.24 shows the physical dimensions of this board.



5.6.1.4 Renesas Ethernet Board Y-COMMON-1000BASE-T1-88Q2112

Figure 5.25 shows the circuit diagram of the Ethernet board Y-COMMON-1000BASE-T1-88Q2112.

The base address of the Marvell PHY is 0x0000.

Note

The former name of this extension board was Y-RH850-1000BASE-T1-88Q2112.

Please check the piggyback board schematic carefully to ensure that on the piggyback board all necessary signals are connected from processor to the main board connector.

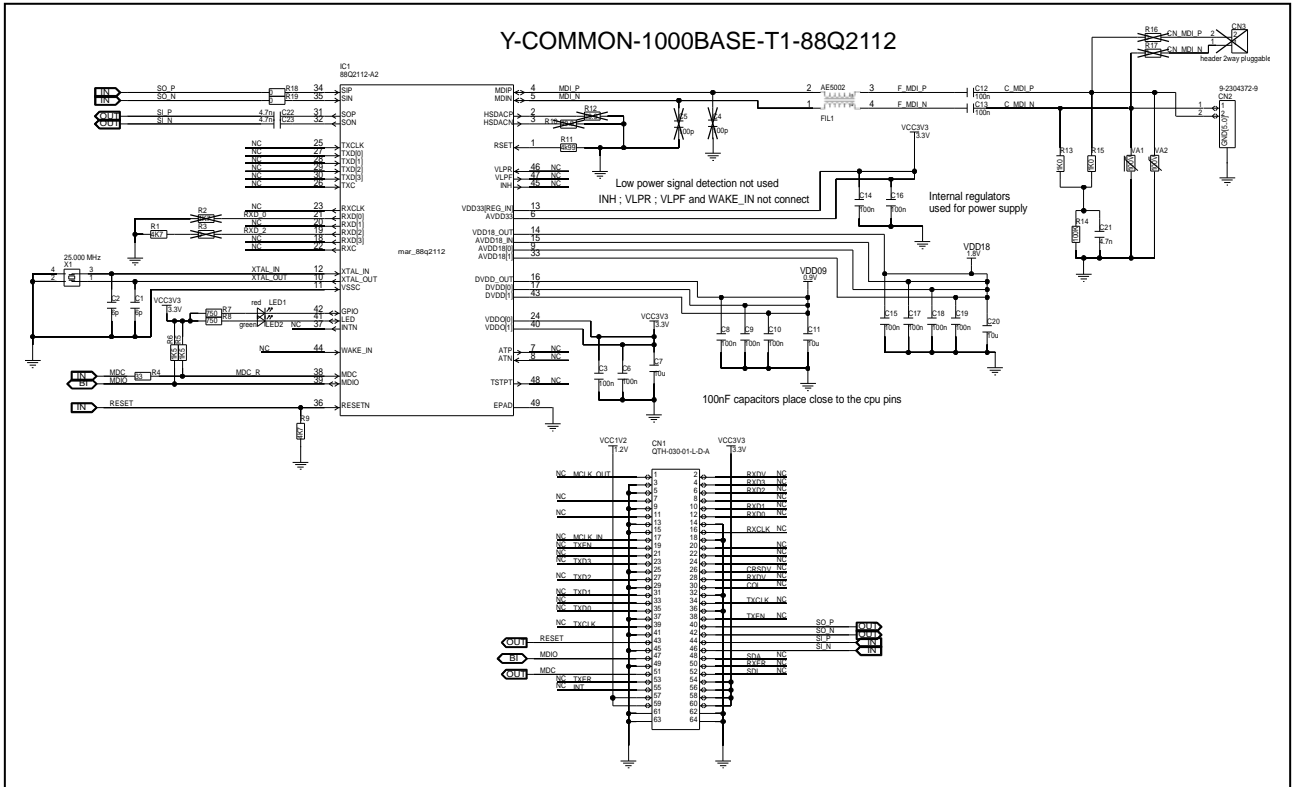

Figure 5.24 Circuit diagram of Renesas Ethernet board Y-COMMON-1000BASE-T1-88Q2112

Figure 5.26 shows the physical dimensions of this board.

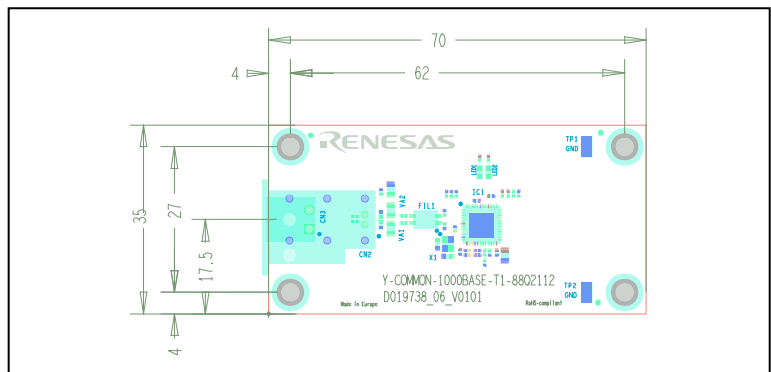

Figure 5.25 Y-COMMON-1000BASE-T1-88Q2112 dimensions

5.6.2 Ethernet Modules Supporting T1S

The main board has one connector for Ethernet modules supporting 10BASE-T1S standard.

Figure 5.27 shows the pin assignment on the connectors for Ethernet modules using 10BASE-T1S on the common main board.

Table 5.15 shows the pin configuration of the connector.

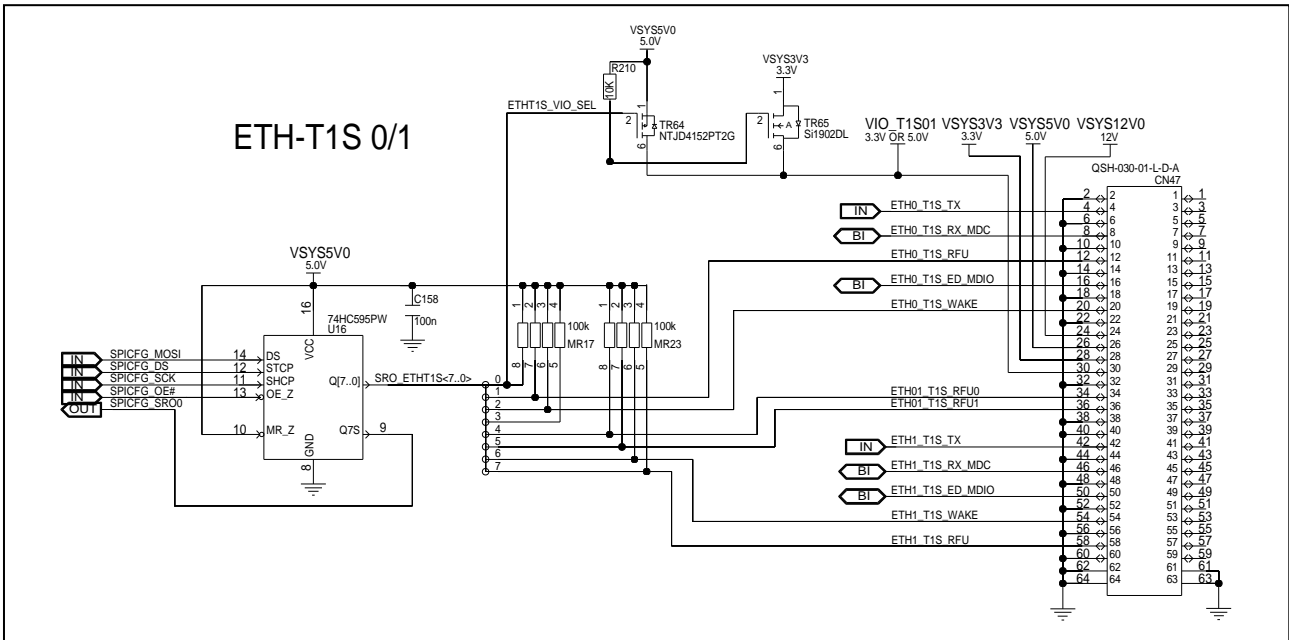

Figure 5.26 Ethernet module connector circuit for 10BASE-T1S compliant Ethernet modules

Table 5.15 Ethernet PHY (T1S) connector CN47 pin assignment

Pin	Function	Pin	Function
1	-	2	GND
3	-	4	ETH0_T1S_TX
5	-	6	GND
7	-	8	ETH0_T1S_RX_MDC
9	-	10	GND
11	-	12	ETH0_T1S_RFU
13	-	14	GND
15	-	16	ETH0_T1S_ED_MDIO
17	-	18	GND
19	-	20	ETH0_T1S_WAKE
21	-	22	GND
23	-	24	VSYS12V0
25	-	26	VSYS5V0
27	-	28	VSYS3V3
29	-	30	VIO_T1S01
31	-	32	GND

Table 5.15 Ethernet PHY (T1S) connector CN47 pin assignment (cont'd)

Pin	Function
33	–
35	–
37	–
39	–
41	–
43	–
45	–
47	–
49	–
51	–
53	–
55	–
57	–
59	–
61	GND
63	GND

Pin	Function
34	ETH01_T1S_RFU0
36	ETH01_T1S_RFU1
38	GND
40	GND
42	ETH1_T1S_TX
44	GND
46	ETH1_T1S_RX_MDC
48	GND
50	ETH1_T1S_ED_MDIO
52	GND
54	ETH1_T1S_WAKE
56	GND
58	ETH1_T1S_RFU
60	GND
62	GND
64	GND

5.6.2.1 Ethernet Board Y-COMMON-10BASE-T1S-xxxx

Renesas provides a standard board for CAN XL interfaces, which can be used with various transceivers.

The board is available in 2 different versions:

- Y-COMMON-10BASE-T1S-NN: No transceiver is assembled on the pcb.
- Y-COMMON-10BASE-T1S-TJA1410A: The NXP transceiver TJA1410A is assembled for channel 0.

Figure 5.27 and Figure 5.28 show the circuit diagram of the Ethernet board Y-COMMON-100BASE-T1S-NN.

Note

Please check the piggyback board schematic carefully to ensure that all necessary signals are connected from the microcontroller to the main board connector on the piggyback board.

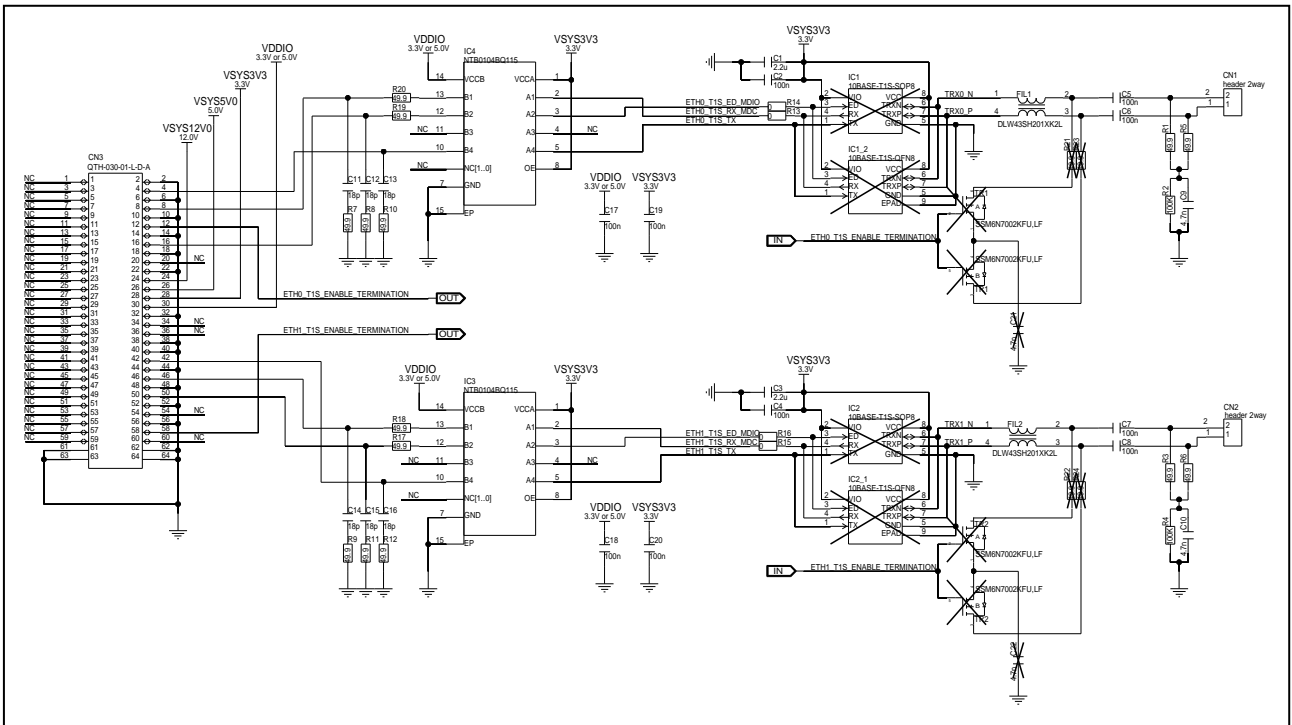

Figure 5.28 Circuit diagram of Renesas Ethernet board Y-COMMON-10BASE-T1S-NN

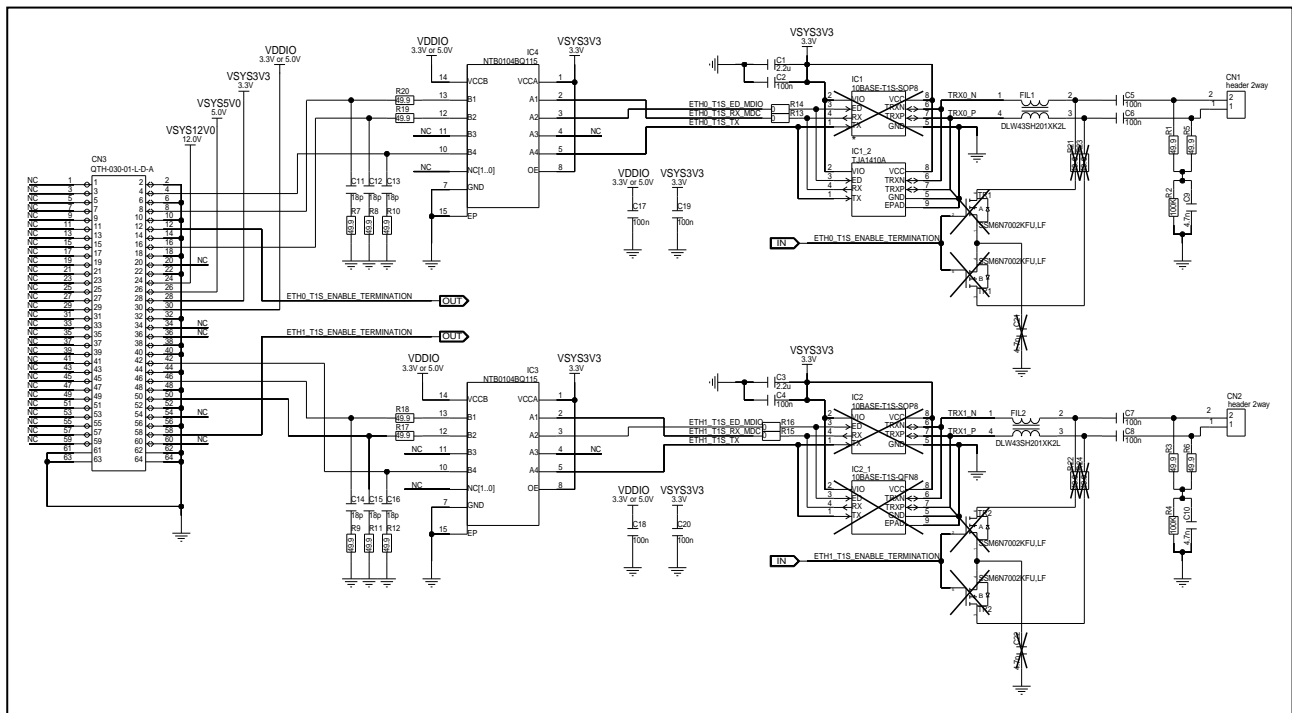

Figure 5.27 Circuit diagram of Renesas Ethernet board Y-COMMON-10BASE-T1S-TJA1410A

Figure 5.29 shows the physical dimensions of this board.

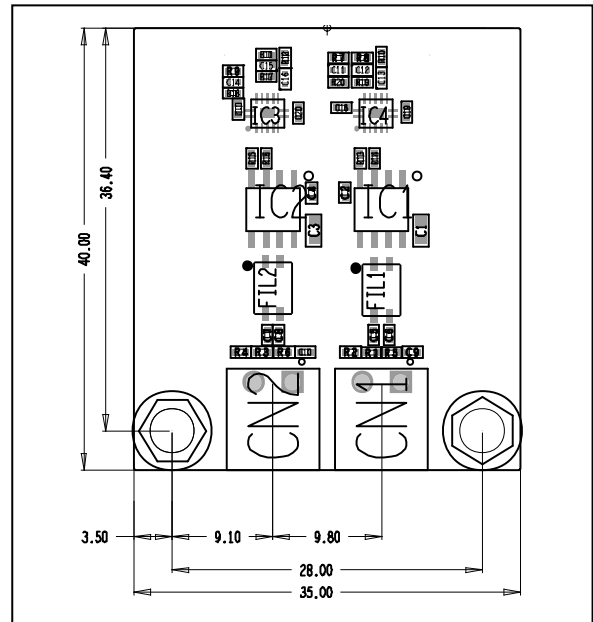

Figure 5.29 Y-COMMON-10BASE-T1S-NN dimensions

5.7 SENT (Single Edge Nibble Transmission) Interfaces

The main board provides the connectors CN11 and CN101 for connecting two SENT interfaces. The SENT extension boards must be ordered from Renesas separately. Please refer to chapter 1.5 *Extension Boards* for details.

The SENT interfaces are controlled by the main board configurator. *Figure 5.30* shows the connections of the board configurator.

Figure 5.31, *Figure 5.32* and *Figure 5.33* show the SENT interface circuit on different main board revisions.

From board version D019712_06_V02 onwards the power supply LEDs LED17 and LED18 have been added.

The main board also has an additional connector CN10, where the signals coming from the microcontroller for both interfaces can be monitored.

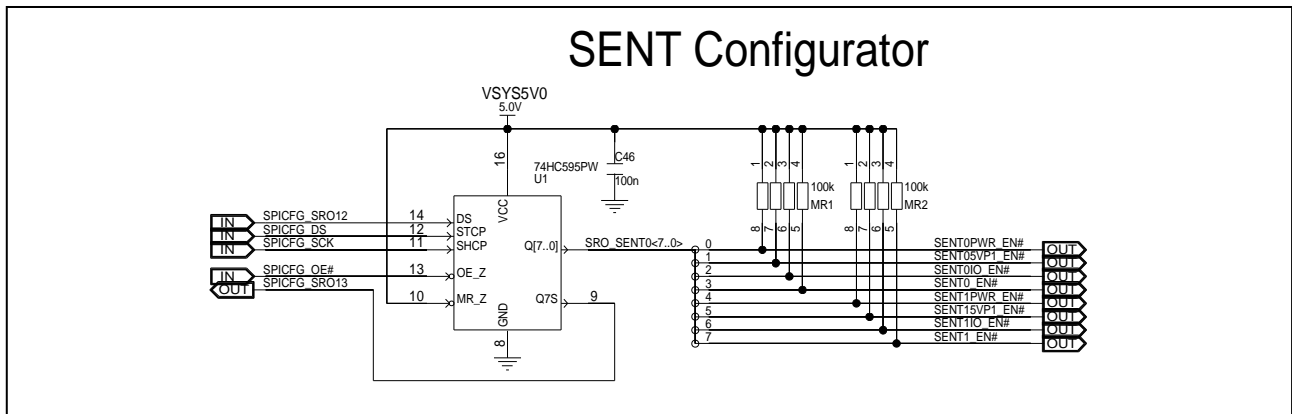

Figure 5.31 SENT interface configurator

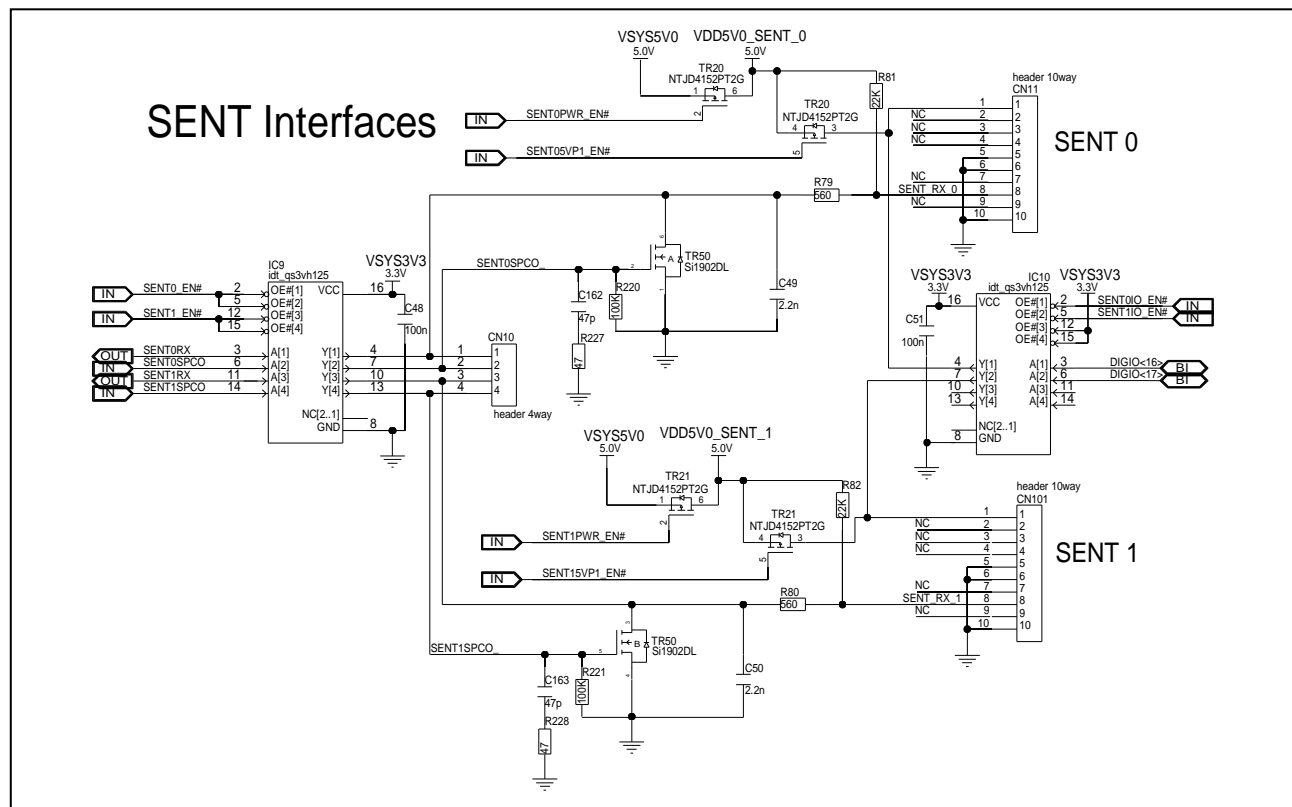

Figure 5.30 SENT interfaces of board version D019712_06_V01

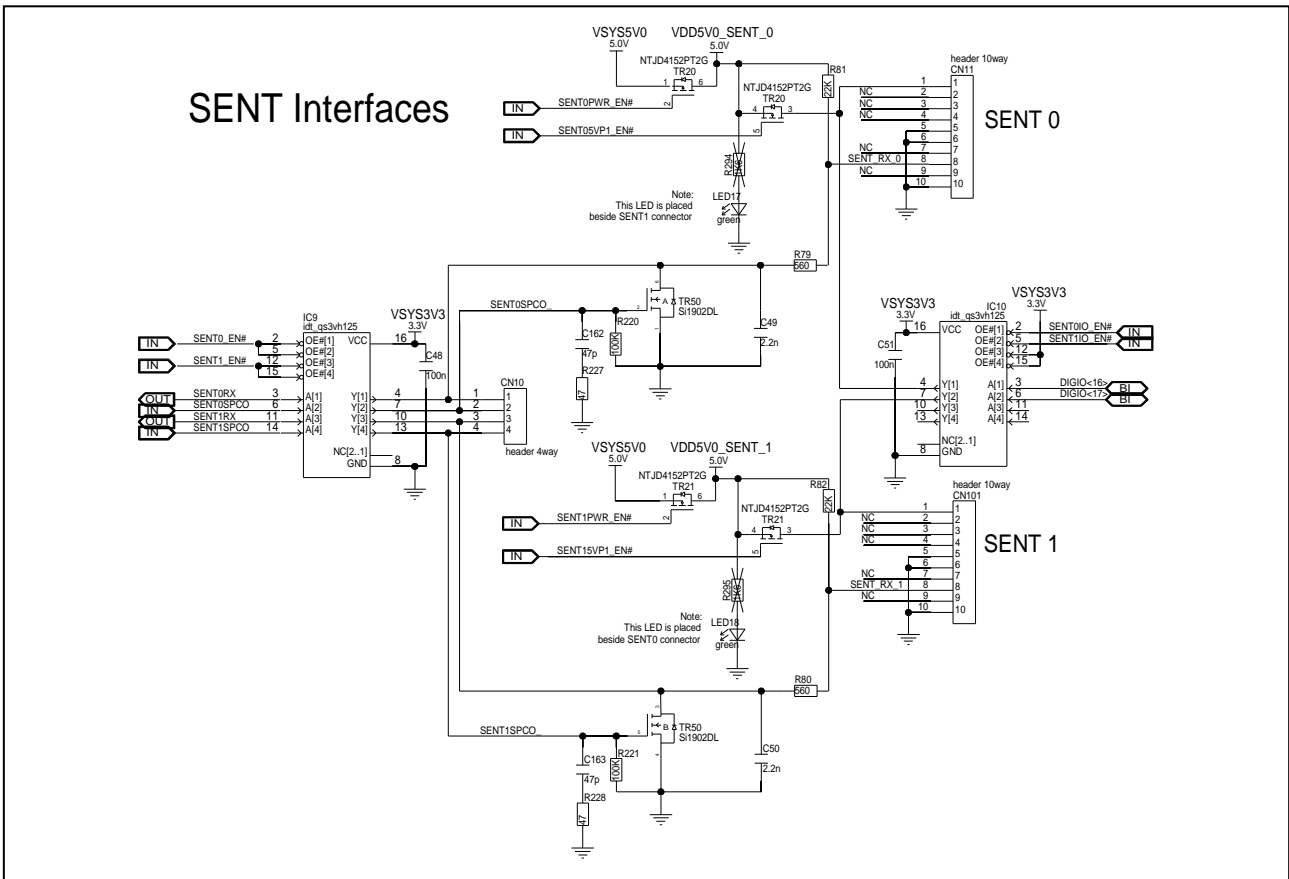

Figure 5.33 SENT interfaces of board version D019712_06_V02

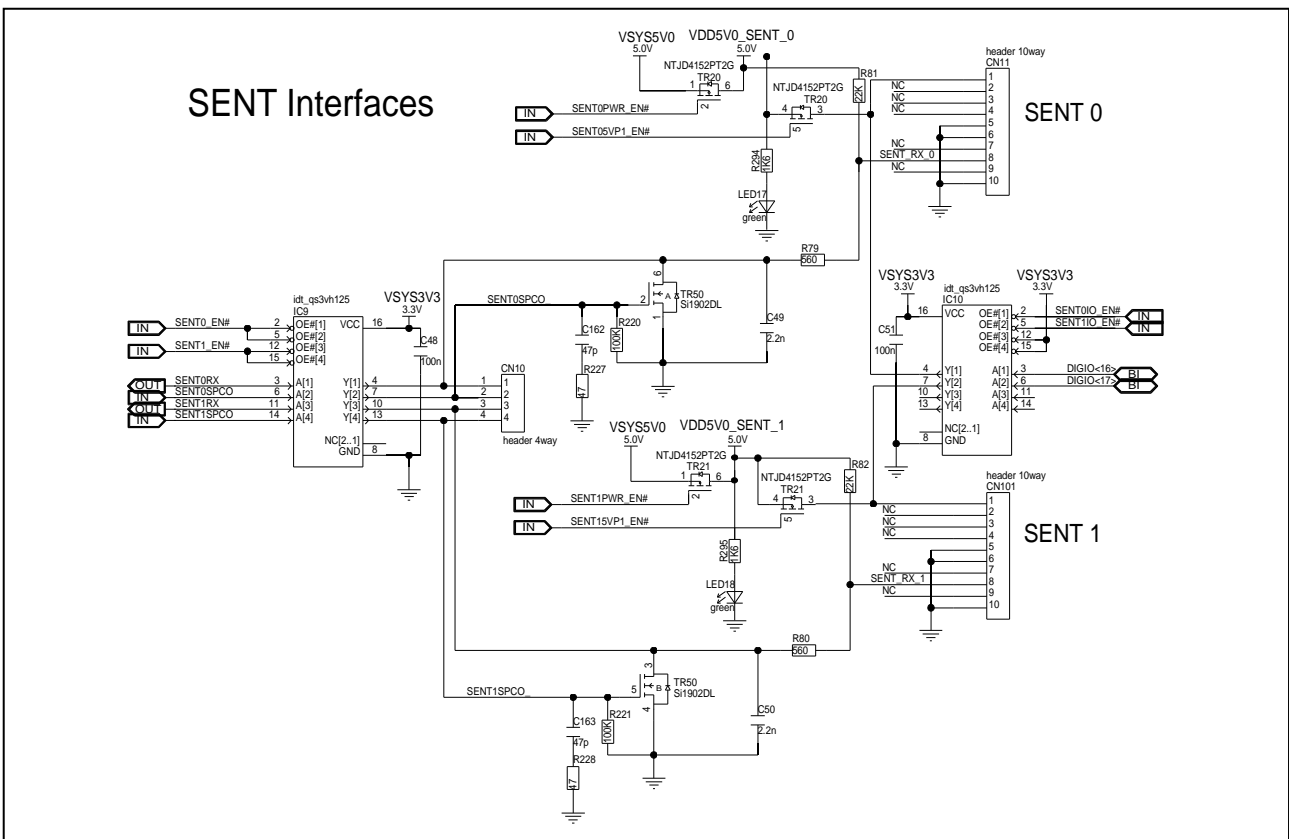

Figure 5.32 SENT interfaces of board version D019712_06_V03 and later

5.7.1 SENT Interface Connectors

Table 5.16 SENT interfaces connectors CN11, CN101

CN11 (SENT0)	
Pin	Function
1	Bus Power / Programming Power SENT0
2	–
3	–
4	–
5	GND
6	GND
7	–
8	SENT_RX_0
9	–
10	GND

CN101 (SENT1)	
Pin	Function
1	Bus Power / Programming Power SENT1
2	–
3	–
4	–
5	GND
6	GND
7	–
8	SENT_RX_1
9	–
10	GND

Table 5.17 SENT monitor connector CN10

CN10	
Pin	Function
1	SENT0RX
2	SENT0SPCO
3	SENT1RX
4	SENT1SPCO

5.8 UART Interfaces

The main board provides two UART interfaces.

The UART0 interface uses connector CN1_LA_1 and shares this with the LIN0 interface. The jumper JP1 selects the interface to be connected to CN1_LA_1:

- JP1[1-2]: UART0
- JP1[2-3]: LIN0

UART1 uses an FTDI chip to provide an USB interface on connector CN6.

On main board version D019712_06_V01 the USB interface uses a Micro-AB type USB 2.0 connector.

On main board version D019712_06_V02 the USB interface uses a Type-C (USB-C) USB connector.

The FTDI chip provides two virtual COM ports to the connected PC.

One virtual COM port is used by the microcontroller on the connected piggyback board as UART1.

The second virtual COM port is the communication port for the RL78 on the main board. This communication port is used for board configuration. Refer to chapter 4 *Main Board Configuration* for details.

The board configurator can enable and control UART0 and UART1 interface.

5.8.1 Circuit Diagram

Figure 5.34 shows the circuit diagram of the UART configuration circuits for board version D019712_06_V01.

Figure 5.35 shows the circuit diagram of the UART configuration circuits for board version D019712_06_V02 and later.

Figure 5.36 to Figure 5.39 show the circuit diagrams for UART0 and UART1 for different board versions.

From board version D019712_06_V02 onwards the power supply LEDs LED19 and LED24 have been added.

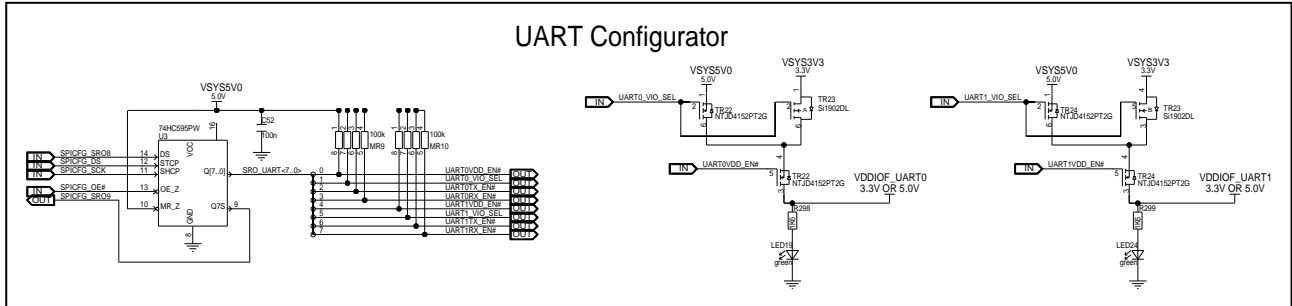

Figure 5.34 Circuit diagram of the UART configuration circuit of board version D019712_06_V01

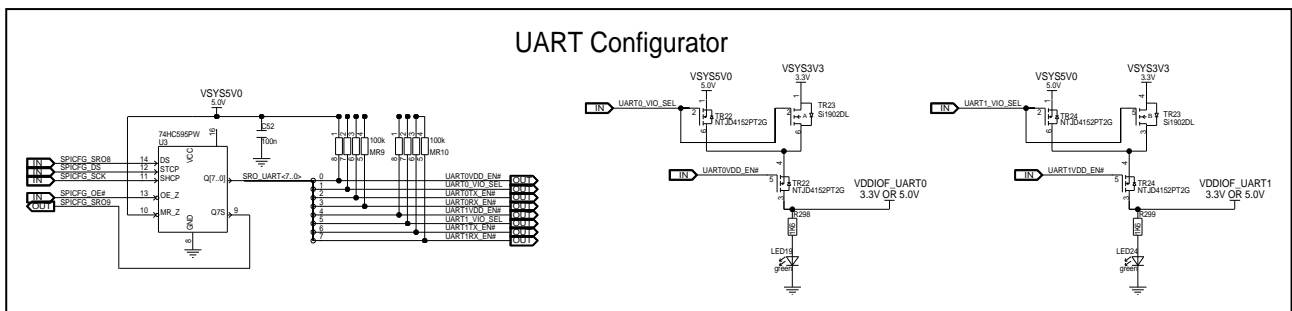

Figure 5.35 Circuit diagram of the UART configuration circuit of board version D019712_06_V02 and later

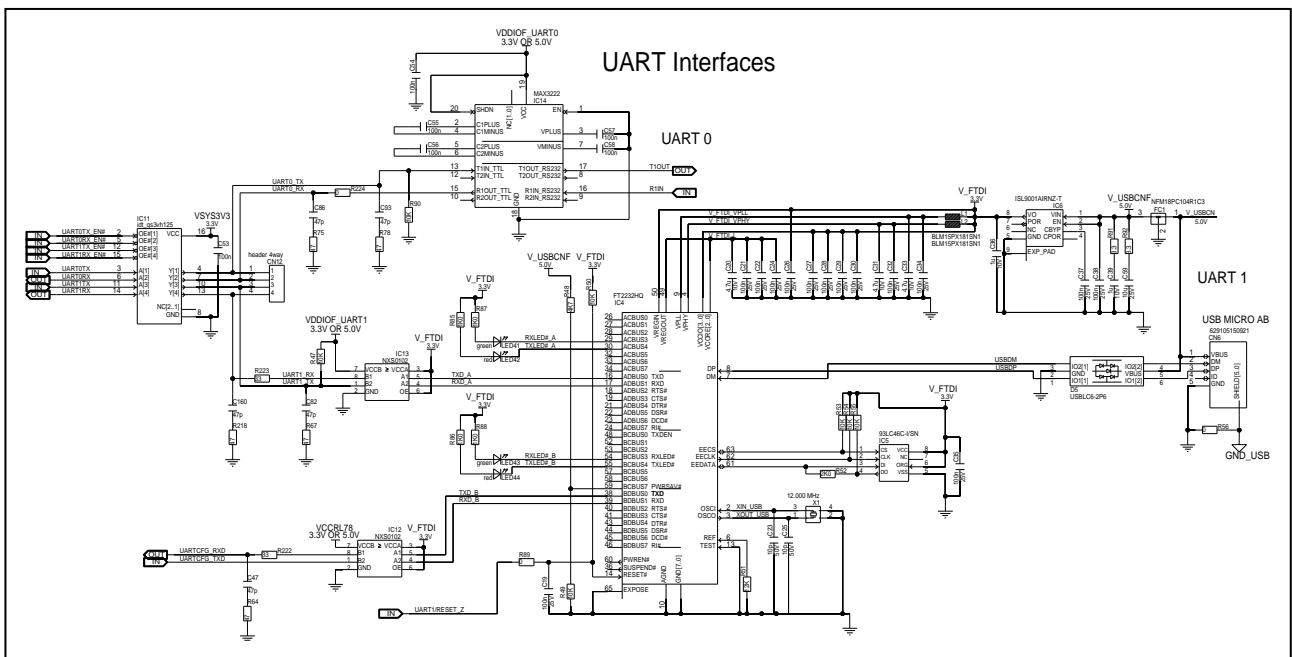

Figure 5.36 UART interface circuit diagram of board version D019712_06_V01

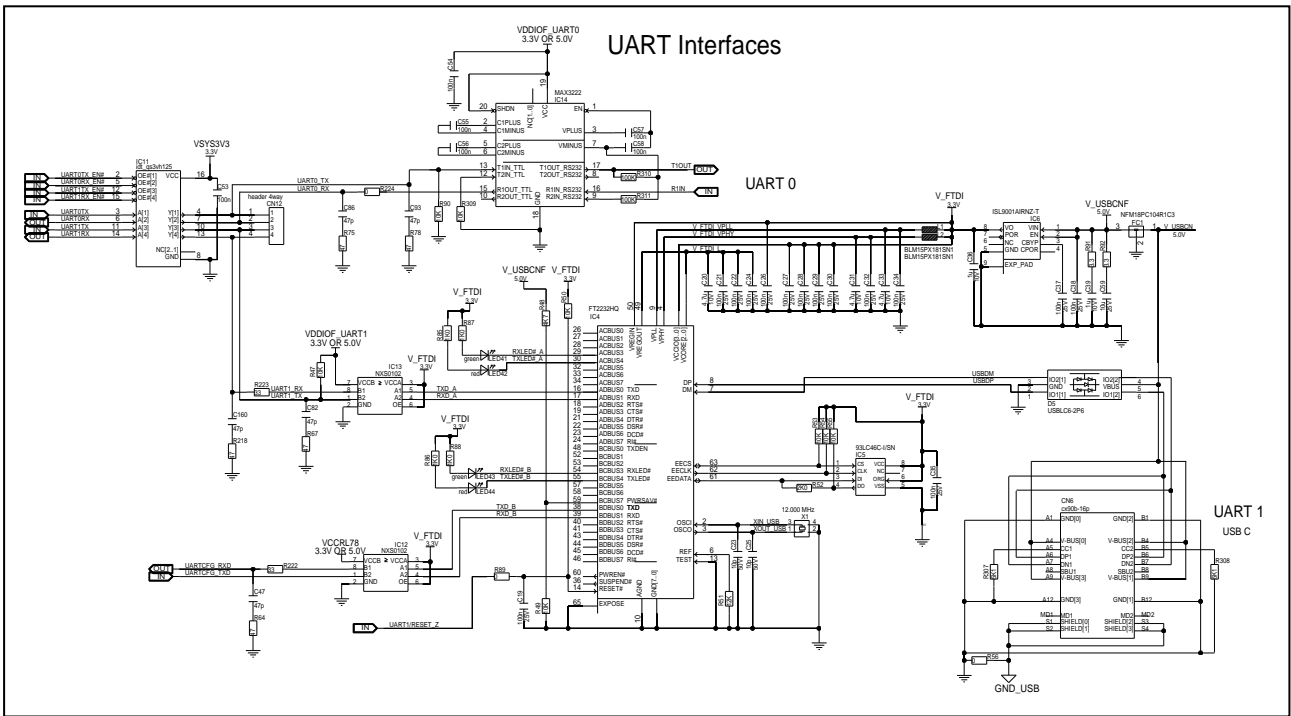

Figure 5.37 UART interface circuit diagram of board version D019712_06_V02

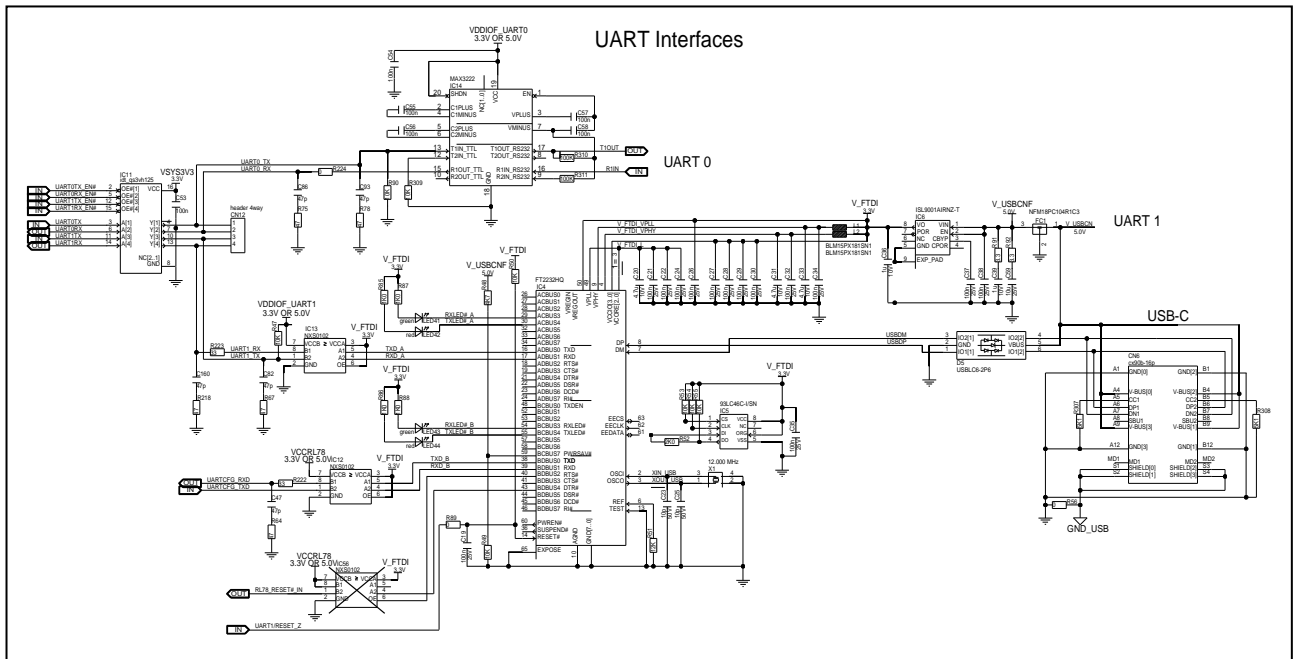

Figure 5.38 UART interface circuit diagram of board version D019712_06_V03

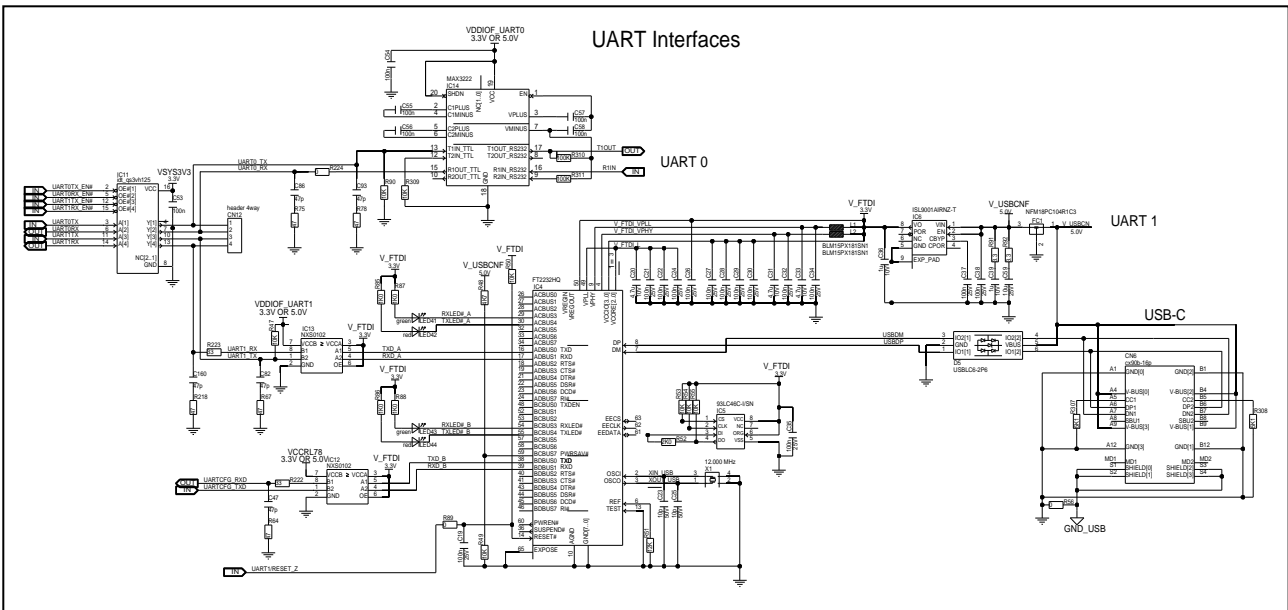

Figure 5.39 UART interface circuit diagram of board version D019712_06_V04 and later

5.8.2 UART Connector

UART1 provides two connectors for UART interfaces.

CN1_LA_1 is used for the UART0 interface.

CN6 is the USB connector for the UART1 interface.

In addition, connector CN12 can be used to monitor the UART signals of UART0 and UART1.

Table 5.18 LIN0 / UART0 interface on 10-pin connectors CN1_LA_1

CN1_LA_1 for LIN0 / UART0		
Pin	Function in LIN0 mode (JP1[2-3])	Function in UART0 mode (JP1[2-1])
1	—	—
2	(R1IN*)	R1IN
3	GND	T1OUT
4	—	—
5	—	—
6	GND	GND
7	LIN0	(LIN0*)
8	—	—
9	LIN0_BAT	(LIN0_BAT*)
10	GND	GND

Note: * These signals are always connected to the related pin but may be irrelevant in the respective mode.

Table 5.19 USB connector CN6 on board version D019712_06_V01

Pin	Function
1	USBVBUS
2	USBDM
3	USBDP

Pin	Function
4	–
5	GND

Table 5.20 USB connector CN6 on board version D019712_06_V02 and later

Pin	Function
A1	GND[0]
A4	V-BUS[0]
A5	CC1
A6	DP1
A7	DN1
A8	SBU1
A9	V-BUS[3]
A12	GND[3]

Pin	Function
B1	GND[2]
B4	V-BUS[2]
B5	CC2
B6	DP2
B7	DN2
B8	SBU2
B9	V-BUS[1]
B12	GND[1]

Table 5.21 UART monitor connector CN12

Pin	Function
1	UART0TX
2	UART0RX
3	UART1TX
4	UART1RX

5.9 Connection Cable for Various Interfaces

The main board includes 8 connection cables from 10-pin DIL to 9-pin D-SUB, which can be used for CAN, LIN, FlexRay, UART0 and SENT connections to external hardware.

The DIL connector can be plugged-in to the connectors for the corresponding interfaces.

Table 5.22 shows the connection between the 10-pin connector and the 9-pin D- SUB connector, and the functions when the cable is connected to any of the interface ports providing 10 pin DIL connector.



Figure 5.40 Interface cable

Table 5.22 Connection between 10-pin connector and 9-pin D-SUB connector

Pin no. on DIL connector	Pin no. on D-SUB connector	Function				
		LINn (n = 0 - 23)	CANn (n = 0-15)	FLEX0 / FLEX1	SENT0 / SENT1	UART0
1	1	–	–	–	DIGIO_16 (CN11, SENT0IO_EN# is enabled) DIGIO_17 (CN101, SENT1IO_EN# is enabled)	–
2	2	(R1IN, only CN14, not used for LIN)	CANnL	FLX0_N (CN20) FLX1_N (CN21)	–	R1IN (RxD)
3	3	GND (if JP9[2-3] is set)	GND (when jumper is closed)	–	–	T1OUT (TxD) (if JP1[1-2] is set)
4	4	–	–	FLX1_N (CN20) – (CN21)	–	–
5	5	–	–	–	GND	–
6	6	GND	–	–	GND	GND
7	7	LINn	CANnH	FLX0_P (CN20) FLX1_P (CN21)	–	(LIN0, not used for UART)
8	8	–	–	FLX1_P (CN20) – (CN21)	SENT_RX_0 (CN11) SENT_RX_1 (CN101)	–
9	9	LINn_BAT	–	–	–	(LIN0_BAT, not used for UART)
10	–	GND	GND	GND	GND	GND

5.10 Serial Flash Memory

The main board is prepared to assemble a serial flash memory IC as IC50 on the lower side of the pcb. This IC is not assembled in production.

Figure 5.41 and Figure 5.42 show the circuit diagrams for the serial flash memory IC. From board version D019712_06_V02 onwards the power supply LED LED28 has been added.

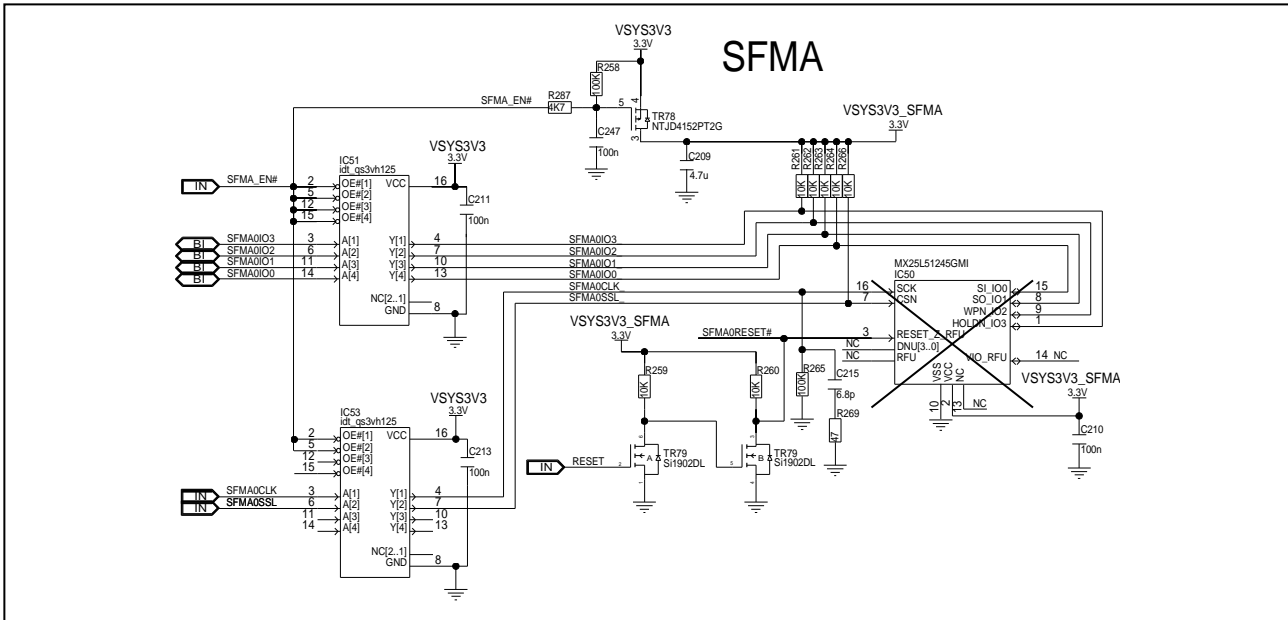

Figure 5.41 SFMA circuit of board version D019712_06_V01

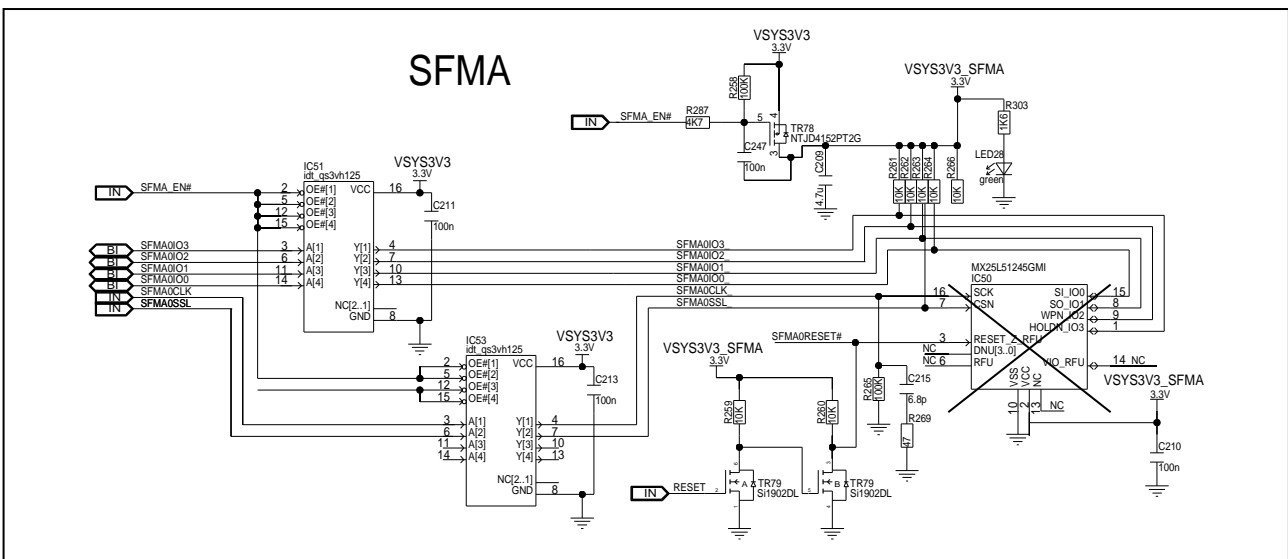

Figure 5.42 SFMA circuit of board version D019712_06_V02 and later

5.11 MicroSD Card Interface

The main board provides a MicroSD card socket on connector CN57. The MicroSD card interface is enabled by the main board configurator.

Figure 5.43 and Figure 5.44 show the circuit diagrams for the MicroSD card interface.

From board version D019712_06_V02 onwards the power supply LED LED27 has been added.

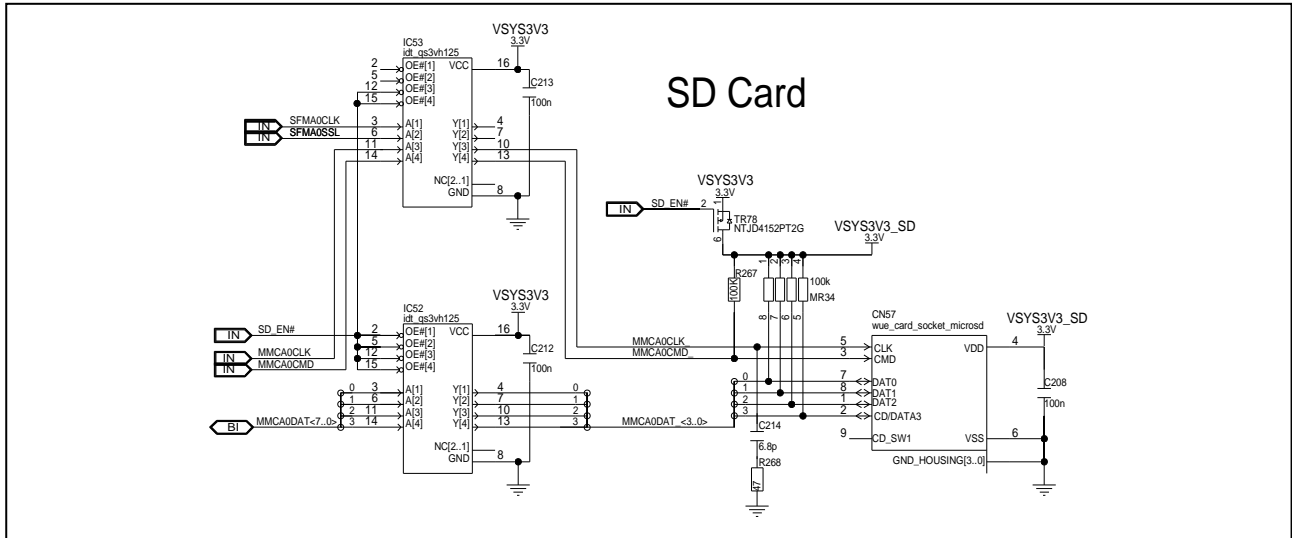

Figure 5.43 MicroSD card circuit of board version D019712_06_V01

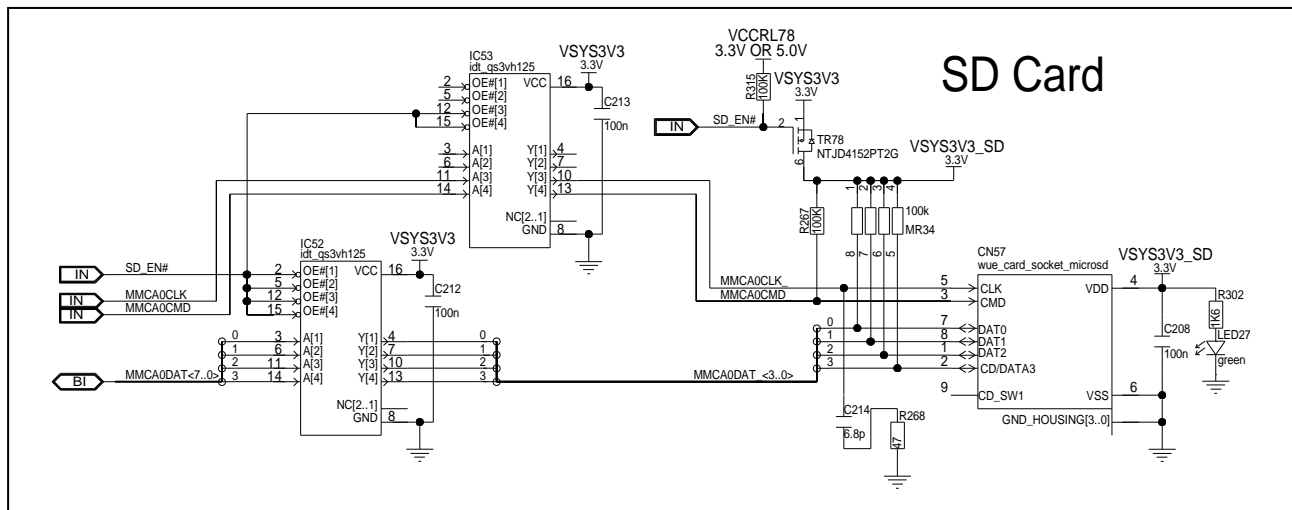

Figure 5.44 MicroSD card circuit of board version D019712_06_V02 and later

5.12 Display

The main board provides connectors for two different displays. Only one display can be used at a time.

Display 0 is a 2.8" TFT display with touch functions for use by the microcontroller on the piggyback board.

Display 1 is a 0.96" OLED display for use by the configuration processor RL78.

5.12.1 TFT Display

The main board is equipped with the sockets CN30 – CN33 to connect a display module. The connection is designed to be used with the Arduino display with capacitive touch by Adafruit (product ID 1947). The TFT display board must be ordered from Renesas separately. Please refer to chapter 1.5 *Extension Boards* for details.

The TFT can be used by the microcontroller on the piggyback board. To use the TFT display from the microcontroller on the piggyback board the I²C level shifter must be enabled by the main board configurator.

5.12.1.1 Circuit Diagram

Figure 5.45 shows the connectors for the TFT display on the main board.

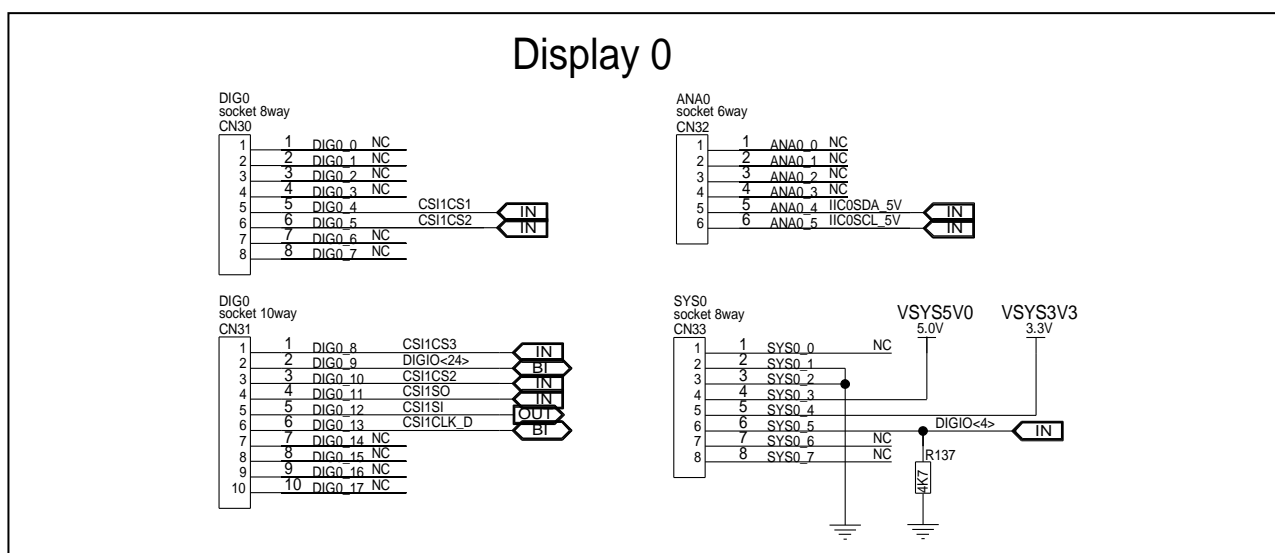

Figure 5.45 Touch screen circuit diagram

5.12.1.2 Usage Information

The 2.8" display is equipped with a capacitive touch controller FT6206.

Figure 5.46 shows the circuit diagram of the TFT with touch controller.

This touch controller can be controlled via I²C interface. The I²C interface it is enabled on the display PCB by connecting the solder bridges for SDA and SCL signals. These bridges are marked with a blue circle in Figure 5.46.

The following documents are available on the internet to set up the display:

- [FT6x06_AN_public_ver0.1.3.pdf](#) (Application Note for FT6x06 CTPM from FocalTech)
- [FT6x06+Datasheet_v0.1_Preliminary_20120723.pdf](#) (Self-Capacitive Touch Panel Controller)
- [Adafruit-2-8-tft-touch-shield-v2.pdf](#) (Adafruit 2.8" TFT Touch Shield v2 from Adafruit learning system)

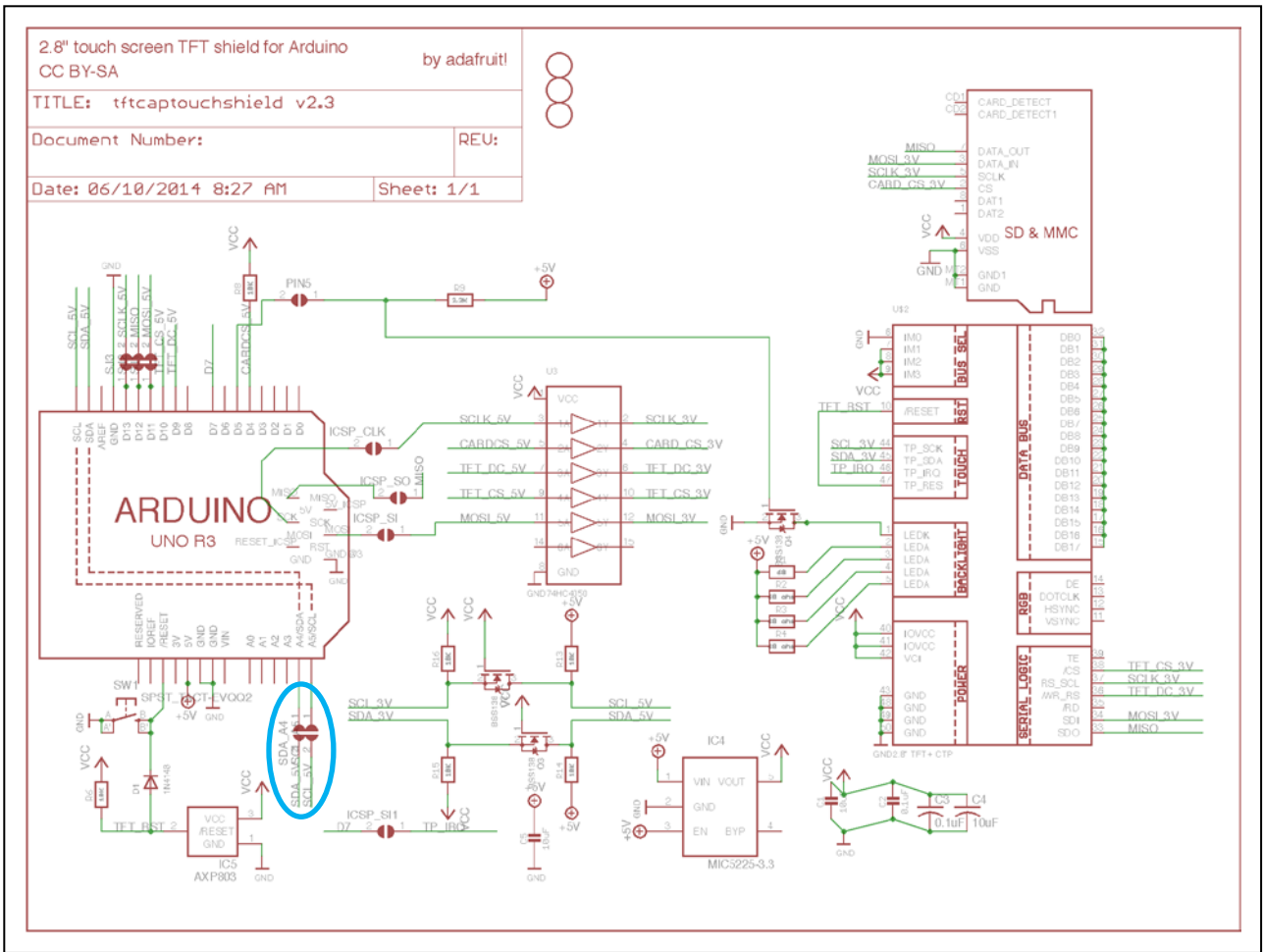

Figure 5.46 Touch display

5.12.1.3 Touch Display Connectors

Table 5.23 Touch Display connectors CN30 to CN33 pin assignment

CN30		CN31		CN32		CN33	
Pin	Function	Pin	Function	Pin	Function	Pin	Function
1	–	1	CSI1CS3	1	–	1	–
2	–	2	DIGIO_24	2	–	2	GND
3	–	3	CSI1CS2	3	–	3	GND
4	–	4	CSI1SO	4	–	4	VSYS5V0
5	CSI1CS1	5	CSI1SI	5	IIC0SDA_5V ¹	5	VSYS3V3
6	CSI1CS2	6	CSI1CLK_D ¹	6	IIC0SCL_5V ¹	6	DIGIO_4
7	–	7	–			7	–
8	–	8	–			8	–
		9	–				
		10	–				

Notes: ¹ These signals can be switched on/off by the main board configurator

5.12.2 OLED Graphic Display

The starter kit includes an [Adafruit 0.96" monochrome OLED display](#).

Figure 5.47 and Figure 5.48 show the circuit diagram of the display connection and the display.

The display is controlled via I2C bus. The I2C address of the display is 0x7A.

The reset input to the display is only connected on board version D017871_06_V03.

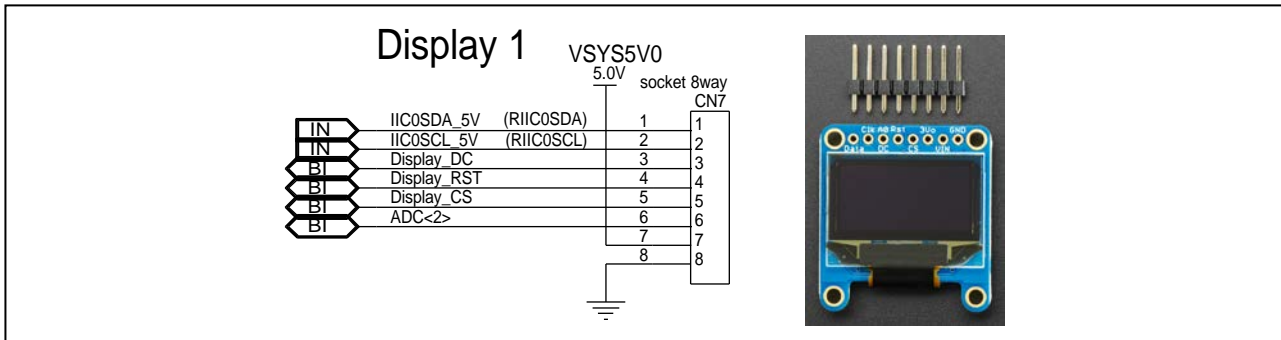

Figure 5.47 OLED display connection of board version D019712_06_V01

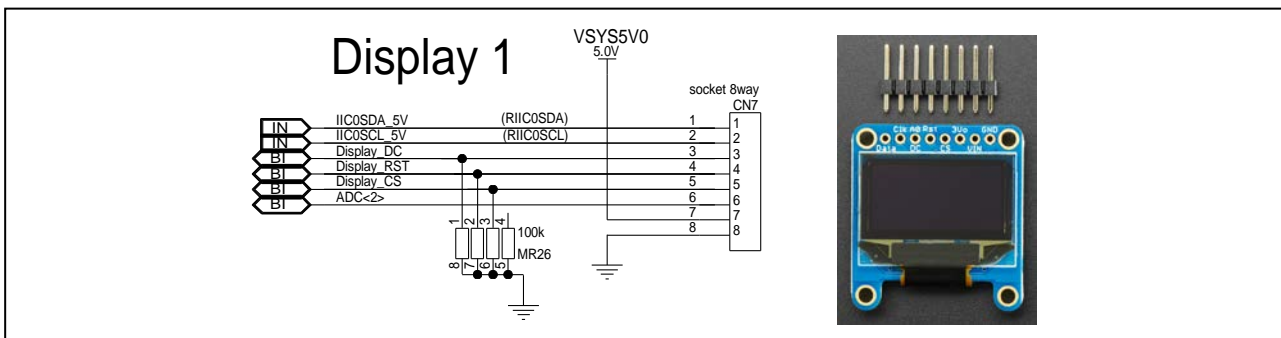

Figure 5.48 OLED display connection of board version D019712_06_V02 and later

Table 5.24 Display connection

Pin	Function	Main Board Signal
1	SDA	IIC0SDA_5V (RIIC0SDA)
2	SCL	IIC0SCL_5V (RIIC0SCL)
3	DC/SA0_5V0	Display_DC
4	RST_5V0	Display_RST
5	CS_5V0	Display_CS
6	3V3	ADC_2
7	VCC	VSYS5V0
8	GND	GND

5.13 Pmod™ Interfaces

The main board includes two Pmod™ interfaces. Each interface uses a 12-pin connector.

The interfaces support 4 different output configurations:

- Expanded SPI (type 2A)
- Expanded UART (type 3A)
- Expanded I2C (type 6A)
- I²S Codec (type 7)

The Pmod outputs are configured using the main board configurator.

Table 5.25 and Table 5.26 show the pin configurations of the Pmod connectors.

Figure 5.49 shows the Pmod configuration signals, Figure 5.50 shows the Pmod circuit diagrams.

Table 5.25 PMOD0 pin configuration

Pin	Exp. SPI (type 2A)		Exp. UART (type 3A)		Exp. I2C (type 6A)		I2S Codec (type 7)	
	Pmod signal	MCU signal	Pmod signal	MCU signal	Pmod signal	MCU signal	Pmod signal	MCU signal
1	CS	CSI0CS0	CTS (GPIO)	CSI0CS0	NC (INT)	INT1	LRCLK	I2S0LRCLK
2	MOSI	CSI0SO	TXD	LIN4TX_P	NC (RESET)	LIN4TX_P	DAC DATA	I2S0TXD
3	MISO	CSI0SI	RXD	LIN4RX_P	SCL	IIC1SCL	ADC DATA	I2S0RXD
4	SCK	CSI0CLK PMOD0	RTS (GPIO)	IIC1SDA	SDA	IIC1SDA	BCLK	I2S0BCLK
5	GND	GND	GND	GND	GND	GND	GND	GND
6	VCC	VSYS PMOD0	VCC	VSYS PMOD0	VCC	VSYS PMOD0	VCC	VSYS PMOD0
7	GPIO (INT)	INT1	GPIO (INT)	INT1	GPIO	DIGIO_16	GPIO	DIGIO_16
8	GPIO (RESET)	DIGIO_17	GPIO (RESET)	DIGIO_17	GPIO	DIGIO_17	GPIO	DIGIO_17
9	GPIO (CS2)	CSI0CS1	GPIO	DIGIO_18	GPIO	DIGIO_18	GPIO (MCLK)	I2S0MCLK
10	GPIO (CS3)	CSI0CS2	GPIO	DIGIO_19	GPIO	DIGIO_19	GPIO	DIGIO_19
11	GND	GND	GND	GND	GND	GND	GND	GND
12	VCC	VSYS PMOD0	VCC	VSYS PMOD0	VCC	VSYS PMOD0	VCC	VSYS PMOD0

Table 5.26 PMOD1 pin configuration

Pin	Exp. SPI (type 2A)		Exp. UART (type 3A)		Exp. I2C (type 6A)		I2S Codec (type 7)	
	Pmod signal	MCU signal	Pmod signal	MCU signal	Pmod signal	MCU signal	Pmod signal	MCU signal
1	CS	CSI1CS0	CTS (GPIO)	CSI1CS0	NC (INT)	INT2_P	LRCLK	I2S1LRCLK
2	MOSI	CSI1SO	TXD	LIN5TX_P	NC (RESET)	CSI1SO	DAC DATA	I2S1TXD
3	MISO	CSI1SI	RXD	LIN5RX_P	SCL	IIC1SCL	ADC DATA	I2S1RXD
4	SCK	CSI1CLK_P	RTS (GPIO)	NC	SDA	IIC1SDA	BCLK	I2S1BCLK
5	GND	GND	GND	GND	GND	GND	GND	GND
6	VCC	VSYSMOD1	VCC	VSYSMOD1	VCC	VSYSMOD1	VCC	VSYSMOD1
7	GPIO (INT)	INT2_P	GPIO (INT)	INT2_P	GPIO	DIGIO_20	GPIO	DIGIO_20
8	GPIO (RESET)	DIGIO_21	GPIO (RESET)	DIGIO_21	GPIO	DIGIO_21	GPIO	DIGIO_21
9	GPIO (CS2)	DIGIO_22	GPIO	DIGIO_22	GPIO	DIGIO_22	GPIO (MCLK)	I2S1MCLK
10	GPIO (CS3)	DIGIO_23	GPIO	DIGIO_23	GPIO	DIGIO_23	GPIO	DIGIO_23
11	GND	GND	GND	GND	GND	GND	GND	GND
12	VCC	VSYSMOD1	VCC	VSYSMOD1	VCC	VSYSMOD1	VCC	VSYSMOD1

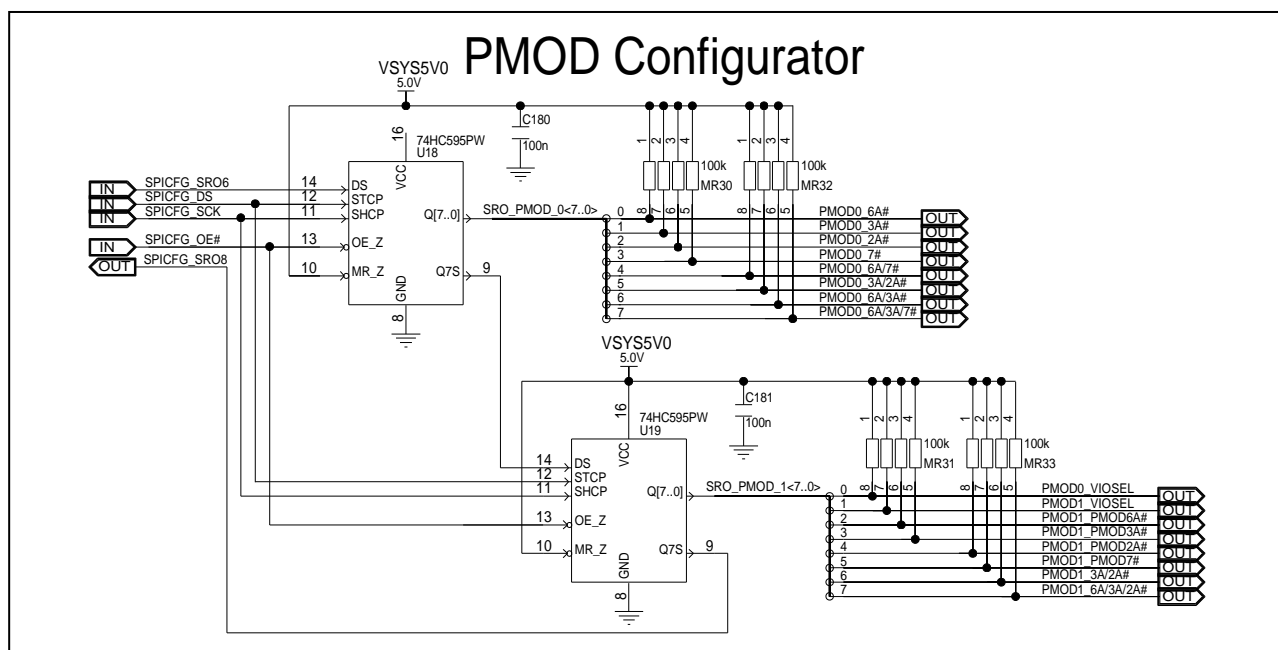

Figure 5.49 Pmod configuration signals

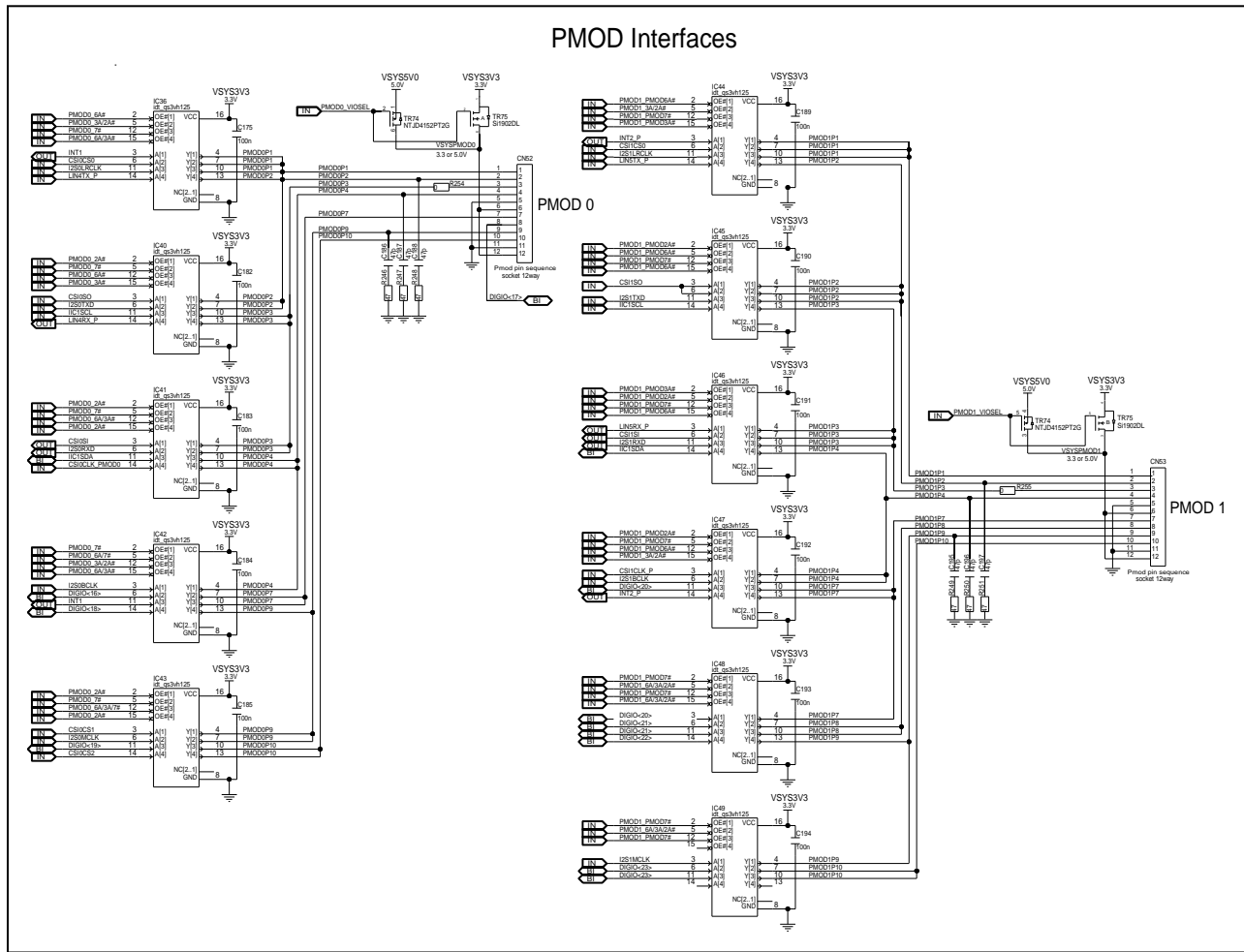

Figure 5.50 Pmod circuit diagrams

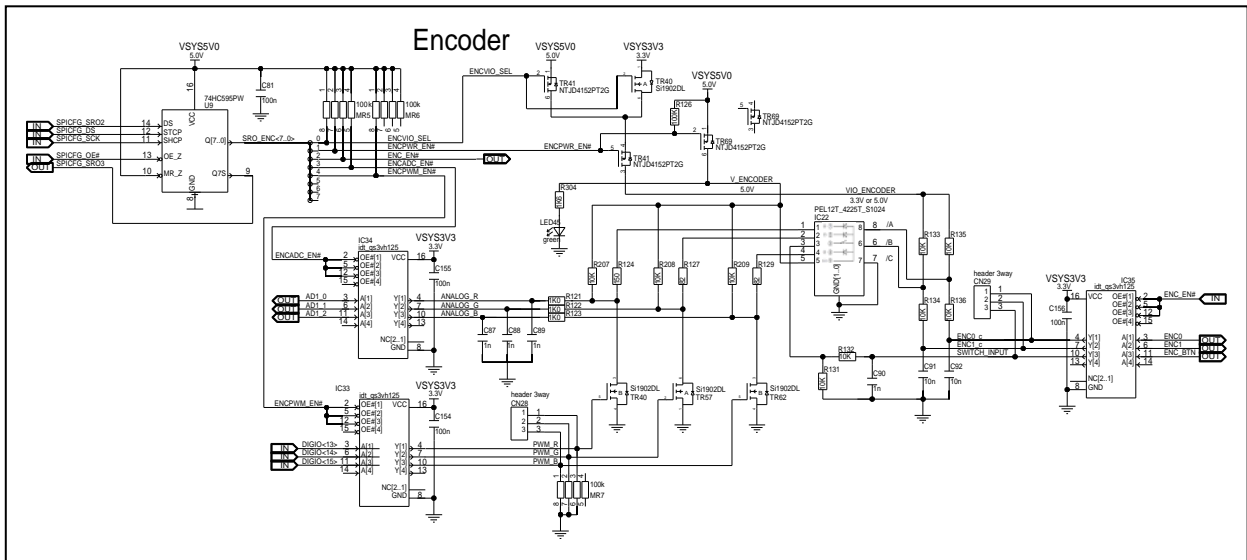

Figure 5.53 Rotary Encoder of board version D019712_06_V03 and later

5.15 LED CSI Driver for LED Ring Indicator

The main board provides a LED ring indicator with 16 blue LEDs.

The ring indicator's 16 LEDs are located around the rotary encoder switch.

They are controlled by an LED driver with CSI interface.

The LED driver is controlled by the main board configurator.

Figure 5.55 and Figure 5.54 show the circuit diagrams of the circular LED circuit.

From board version D019712_06_V02 onwards the power supply LED LED46 has been added.

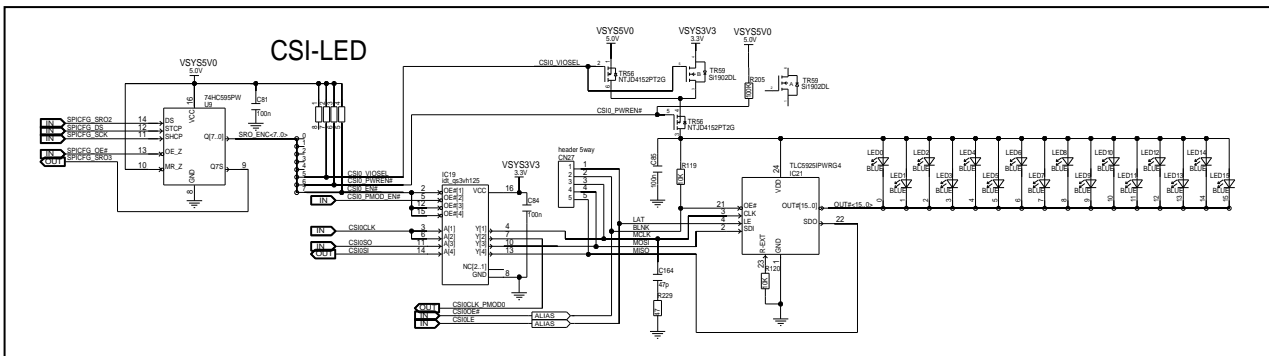

Figure 5.55 LED CSI driver for LED ring indicator of board version D019712_06_V01

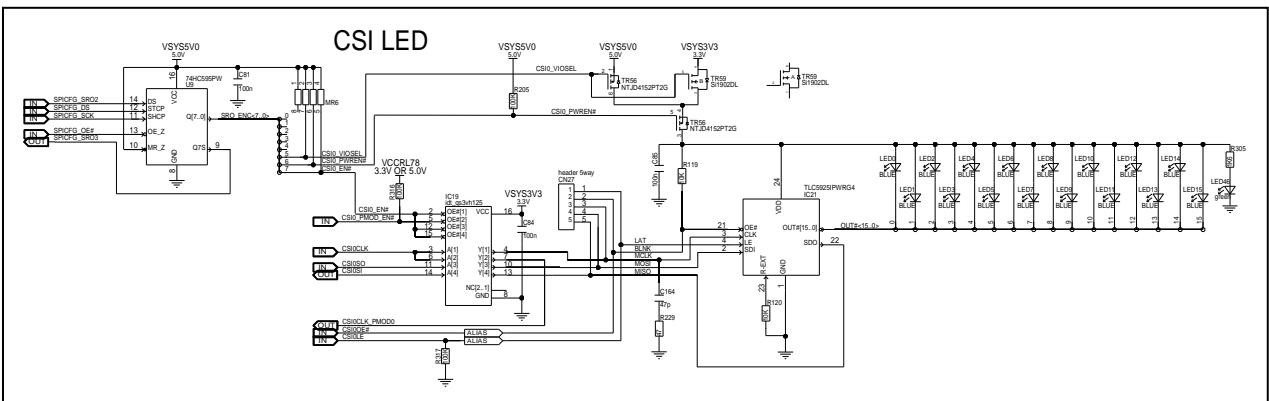

Figure 5.54 LED CSI driver for LED ring indicator of board version D019712_06_V02 and later

The main board incorporates connector CN27, which can be used to monitor the CSI signals.

Table 5.27 Connector CN27 pin assignment

Pin	Board signal	CSI driver signal	Description
1	CSI0LE	LAT	Data strobe
2	CSI0OE#	BLNK	Output enable
3	CSI0CLK	MCLK	Clock input
4	CSI0SO	MOSI	Serial data output
5	CSI0SI	MISO	Serial data input

5.16 Motor Control Circuit

The main board has two connectors to connect to external motors.

Both motor connectors are connected permanently and do not need to be enabled using the main board configurator.

Motor 0 includes 3 LEDs (LED29, LED30, LED31) to monitor the motor control signals. On main board versions D019712_06_V01 and D019712_06_V02 these LEDs are always connected to the motor control signals. On main board version D019712_06_V03 the LEDs are activated by the Main Board Configurator.

Figure 5.56 and Figure 5.57 show the circuit diagram of motor 0 on different main board revisions, Figure 5.58 shows the connector for motor 1 on all board revisions.

Figure 5.56 shows the circuit diagram of motor 0 on main board revision D019712_06_V01 and D019712_06_V02.

Figure 5.57 shows the circuit diagram of motor 0 on main board revision D019712_06_V03 and later.

Figure 5.58 shows the connector for motor 1 on all main board revisions.

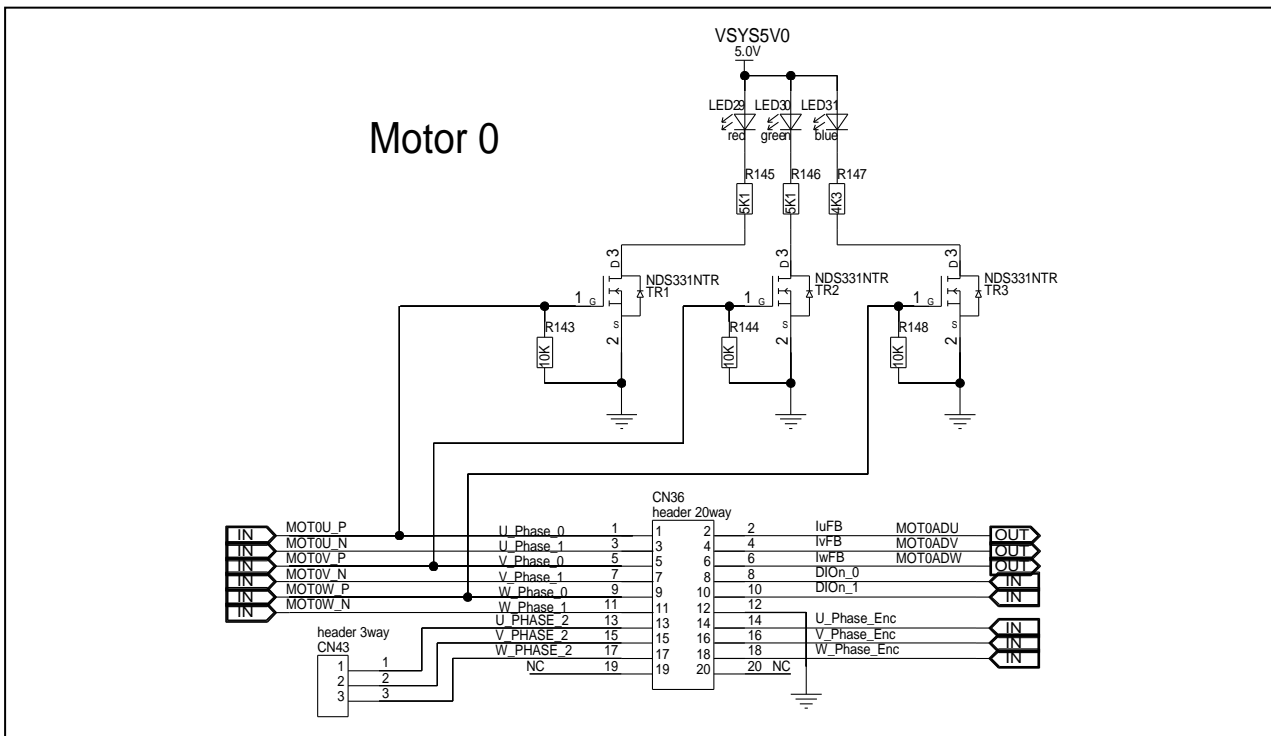

Figure 5.56 Motor control circuit Motor 0 of board versions D019712_06_V01 and D019712_06_V02

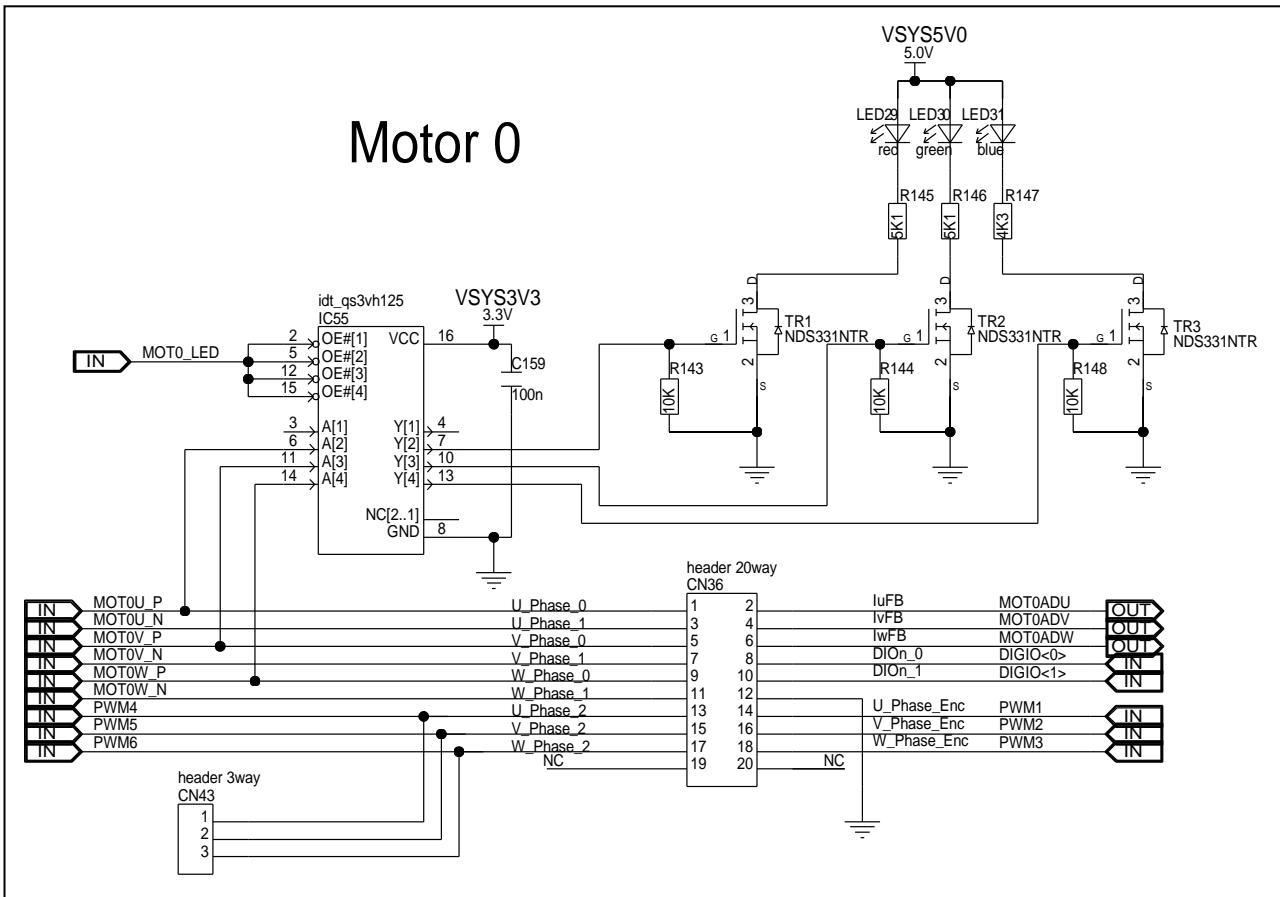

Figure 5.58 Motor control circuit Motor 0 of board versions D019712_06_V03 and later

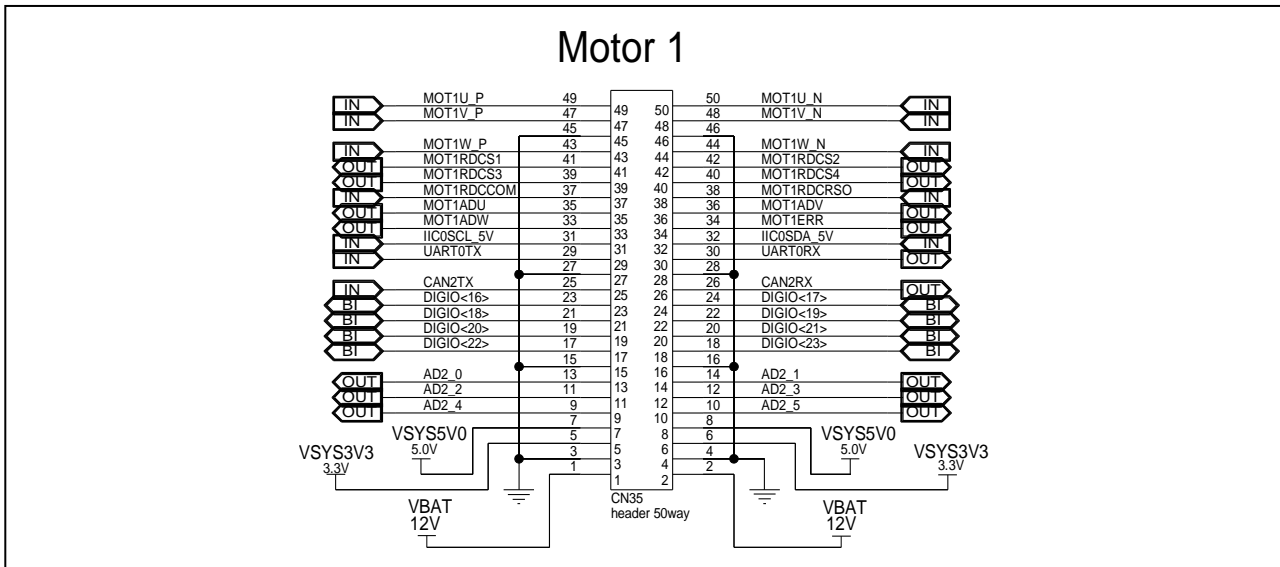

Figure 5.57 Motor control circuit Motor 1

5.16.1 Motor Control Extension Board Y-COMMON-BLDC-MOTOR-DRV

The motor control extension board is used to connect a BLDC motor to common main board or to a suitable starter kit.

On the left side the extension board has the connectors for the motor.

On the right side the extension board has the connectors for the main board or the starter kit.

For details on the motor control extension board refer to the manual of this board (to be released).

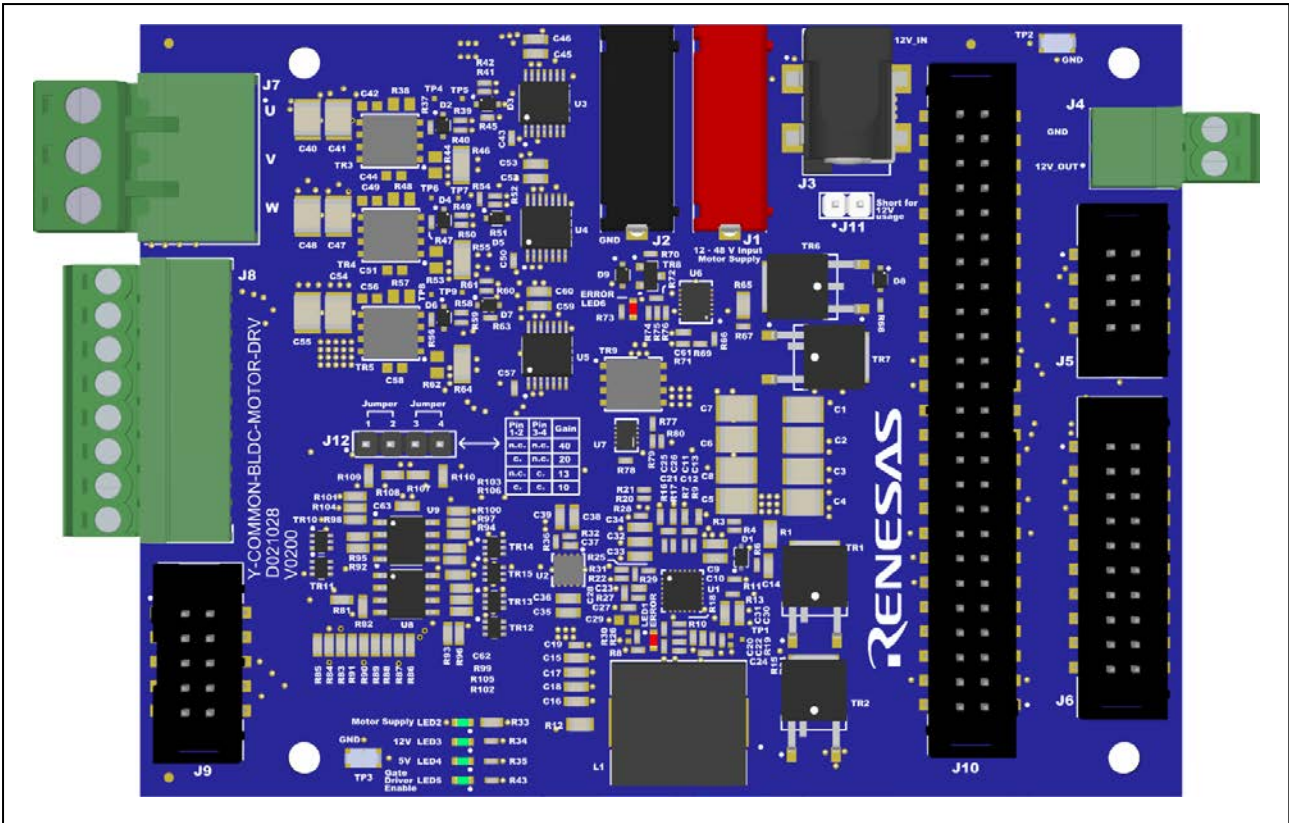

Figure 5.59 Connectors on the motor control extension board

5.17 Resolver Circuit

The main board includes a resolver circuit. It is enabled and controlled by the main board configurator.

Figure 5.60 shows the control signals of the main board configurator used to configure the resolver circuit on board revisions D019712_06_V01 and D019712_06_V02.

Figure 5.61 shows the control signals of the main board configurator used to configure the resolver circuit on board revision D019712_06_V03.

Figure 5.62 shows the resolver circuit diagram of the resolver circuit on board revisions D019712_06_V01 and D019712_06_V02.

Figure 5.63 shows the resolver circuit diagram of the resolver circuit on board revisions D019712_06_V01 and D019712_06_V02.

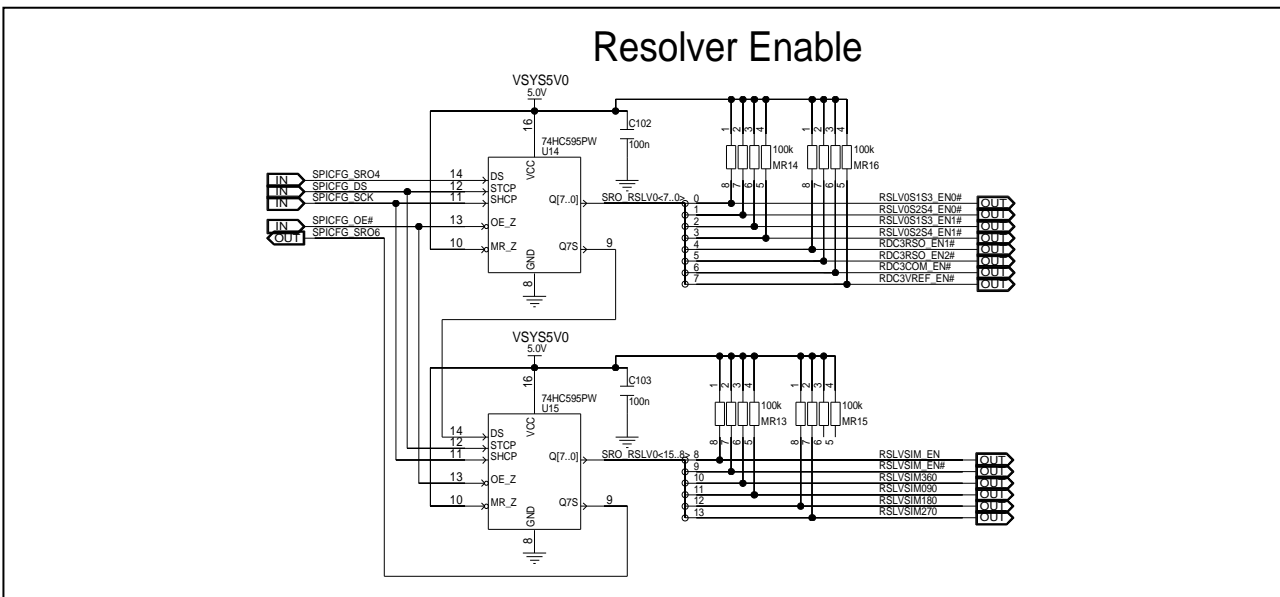

Figure 5.60 Resolver enable signals of board version D019712_06_V01 and D019712_06_V02

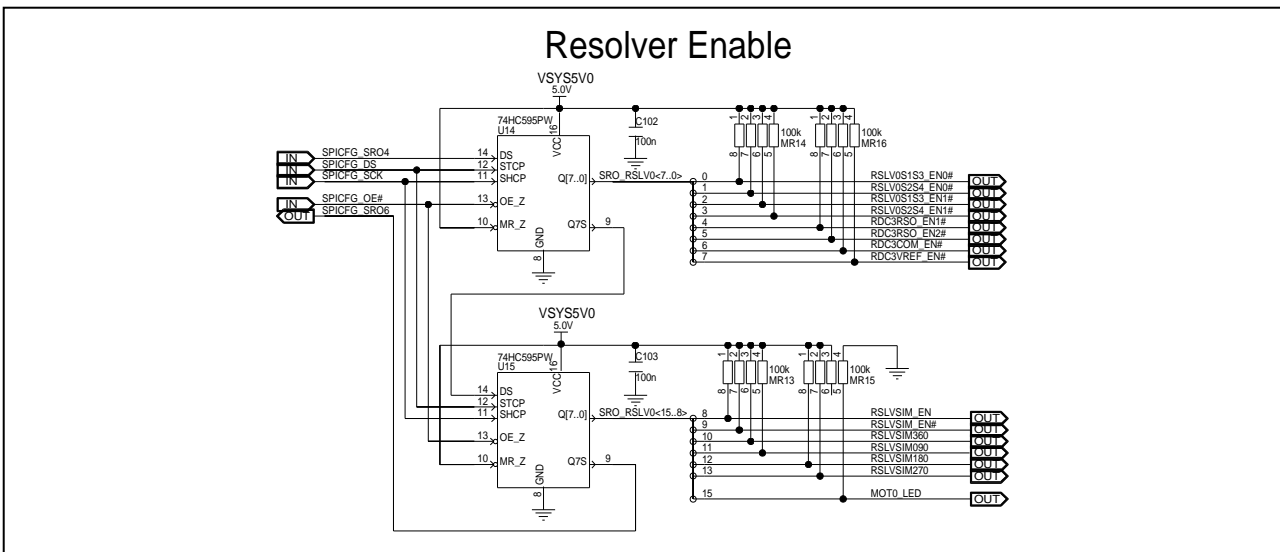

Figure 5.61 Resolver enable signals of board version D019712_06_V03

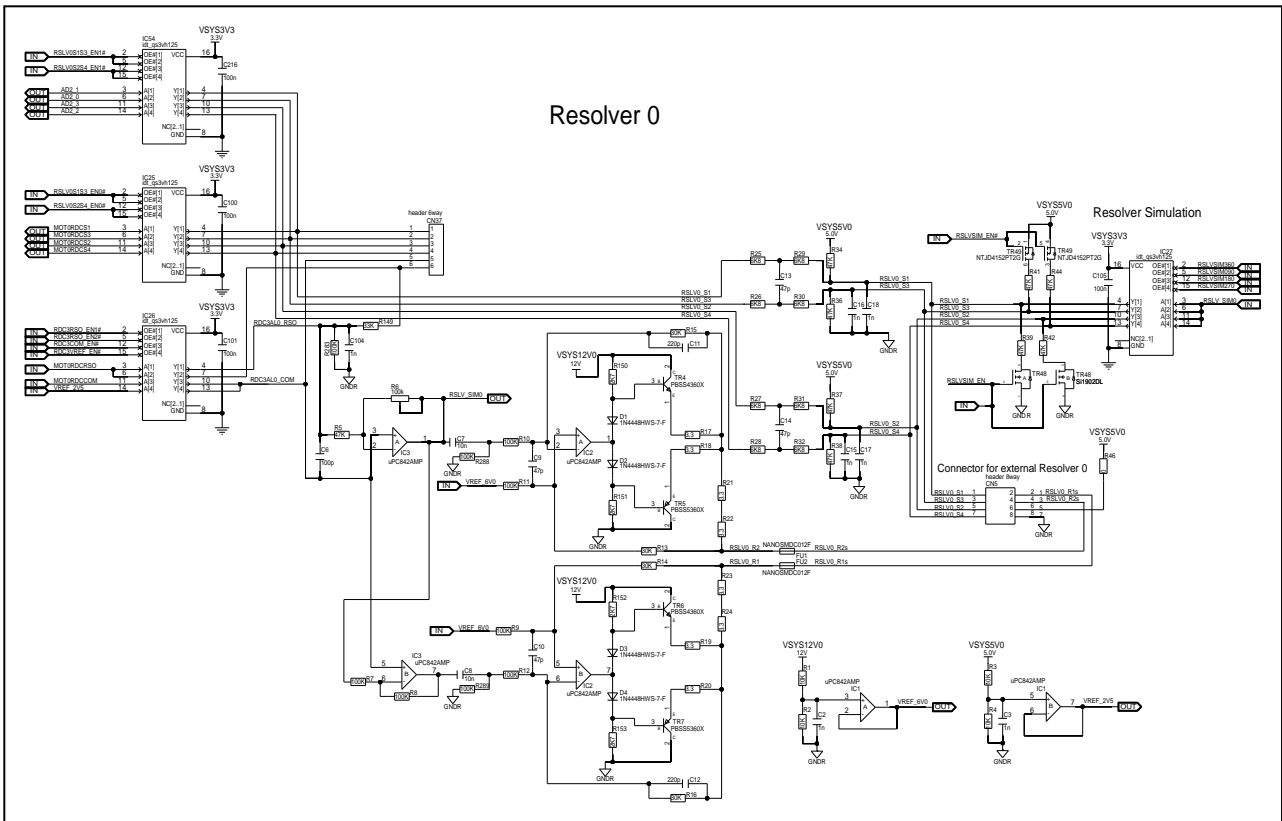

Figure 5.62 Circuit diagram resolver circuit of board version D019712_06_V01 and D019712_06_V02

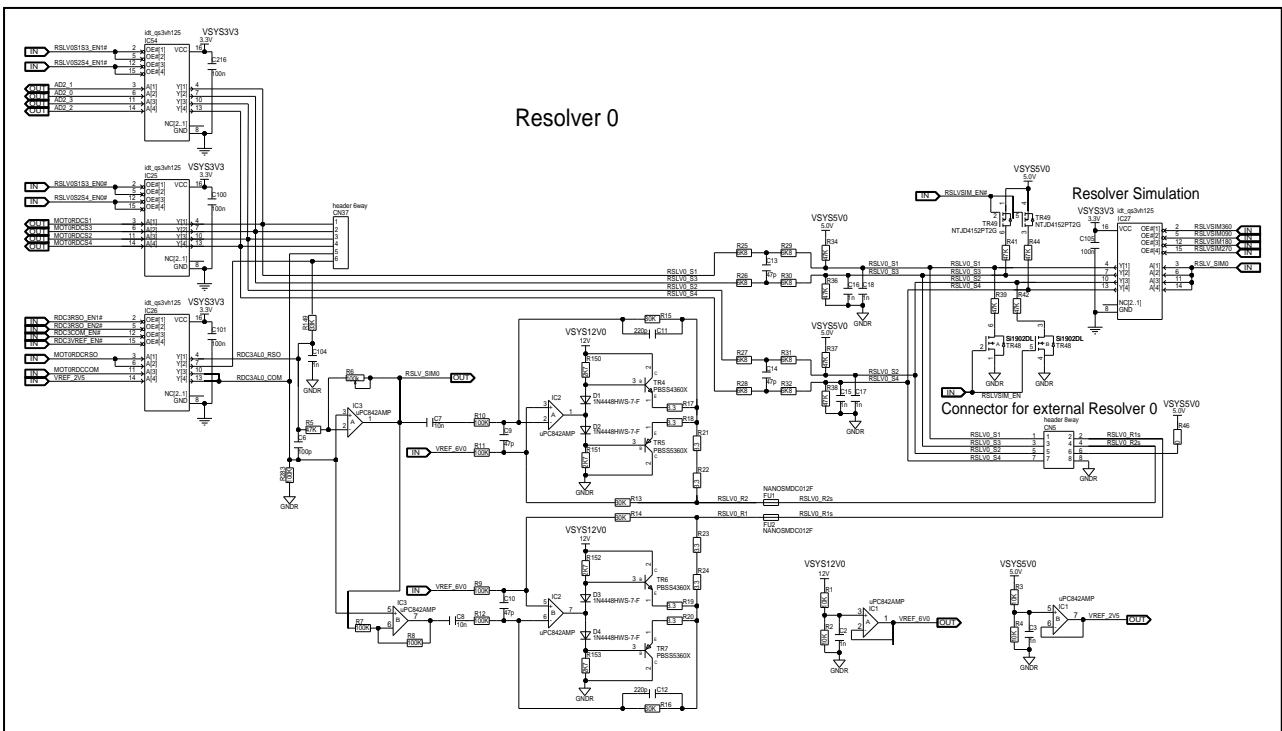

Figure 5.63 Circuit diagram resolver circuit of board version D019712_06_V03

5.18 Interrupt Push Buttons

Two push buttons are available to trigger the interrupts NMI and INT0:

- Push button SW52 issues an NMI signal
- Push button SW53 issues an INT0 signal

The pin header CN49 can be used to output the signals to some other external hardware.

Figure 5.64 shows the circuit diagram of the interrupt switches.

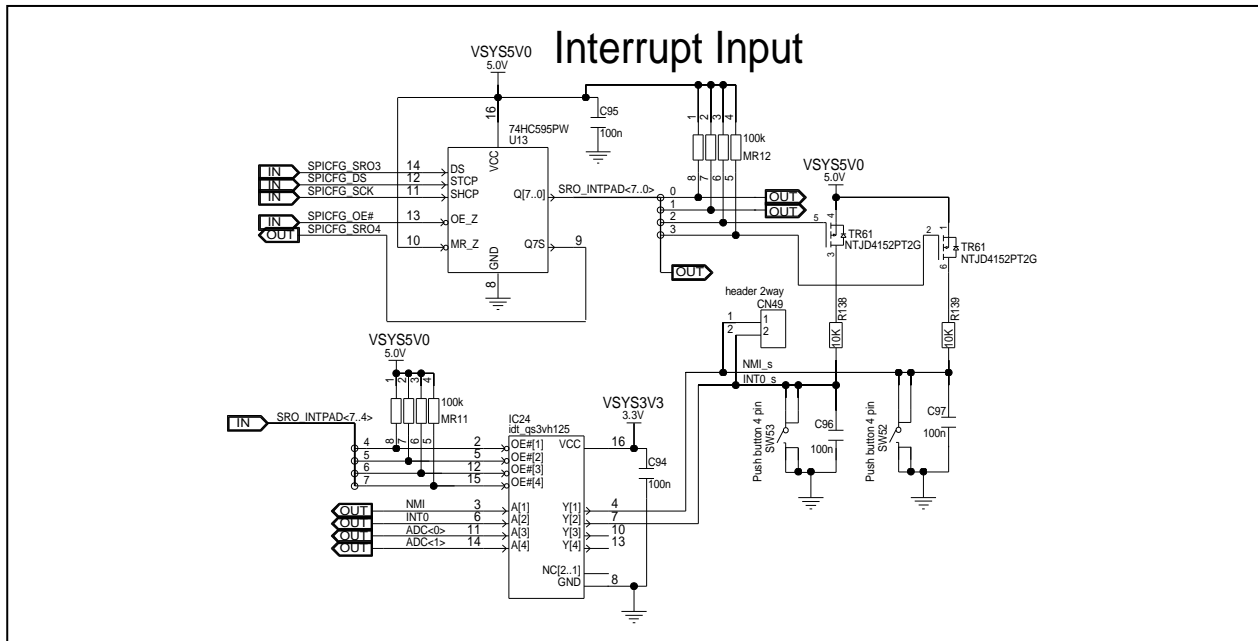

Figure 5.64 Interrupts push buttons

5.19 A/D Measurements

The main board includes 2 potentiometer circuits in order to provide variable voltage levels on the ADC[1:0] signals as inputs to the microcontroller's A/D Converter.

- POT11 generates a signal for ADC[0].
- POT12 generates a signal for ADC[1].

The analog voltages can be checked on CN34 pin header.

The voltage can be adjusted between VDDIOF_ADC and GND.

The AD inputs are enabled using the main board configurator.

Figure 5.65 and Figure 5.66 show the A/D measurement circuit.

From board version D019712_06_V02 onwards the power supply LED LED47 has been added.

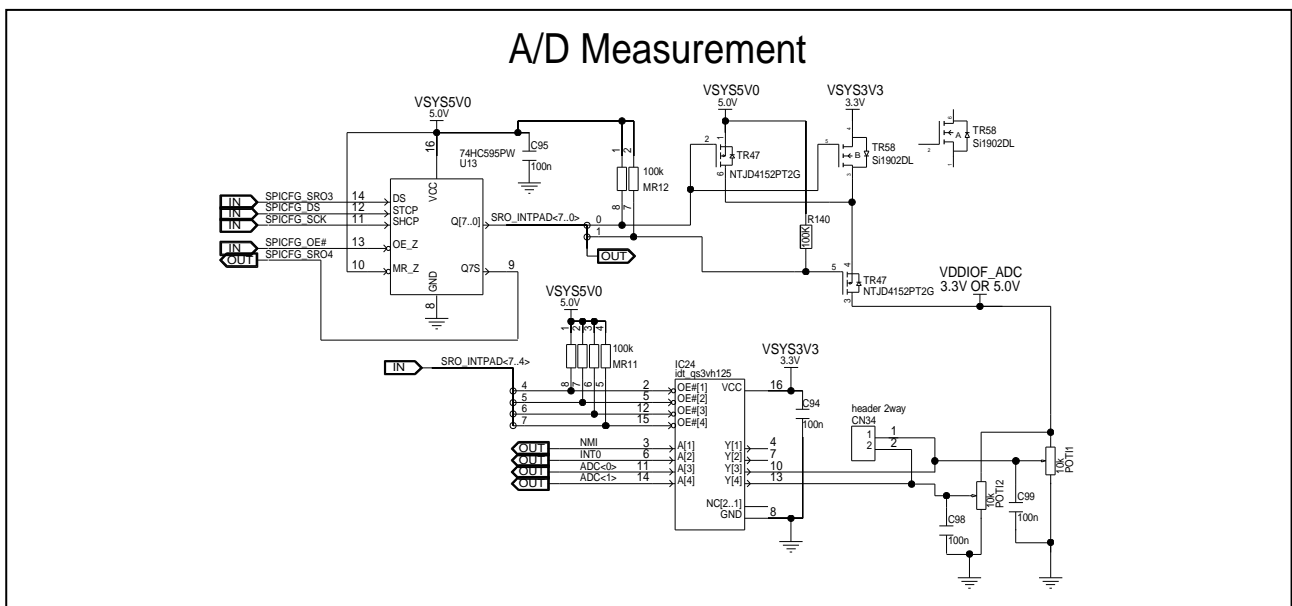

Figure 5.65 A/D measurements of board version D019712_06_V01

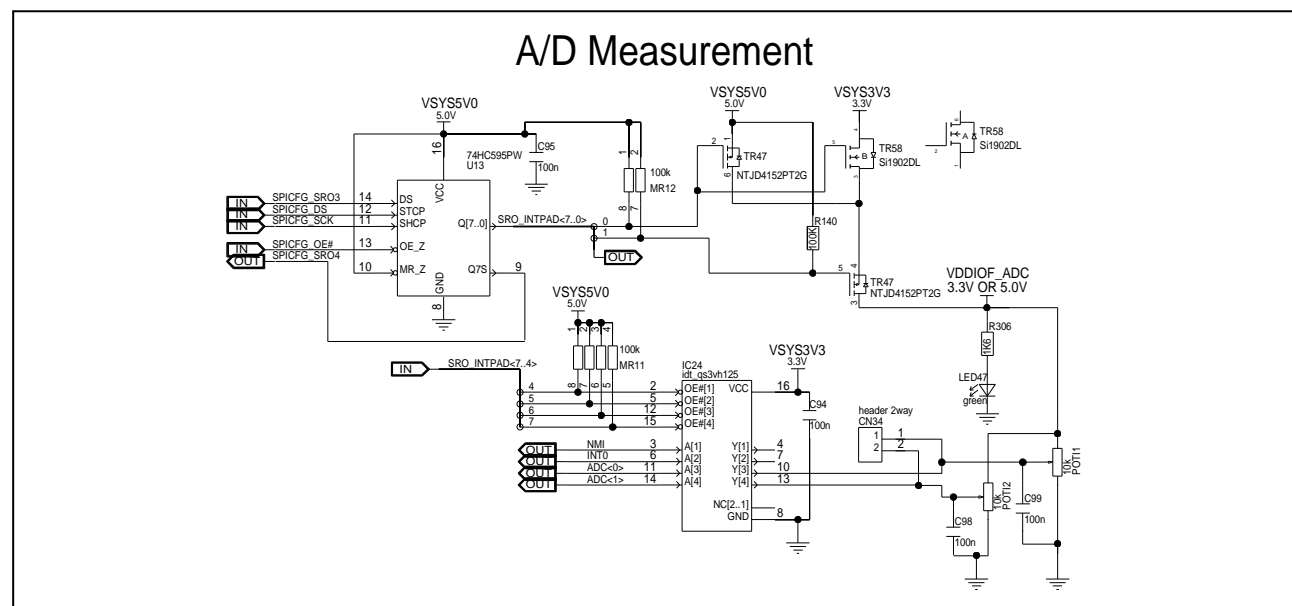

Figure 5.66 A/D measurements of board version D019712_06_V02 and later

5.20 Signal LEDs

Four blue LEDs are provided to allow visual outputs of four signals.

The four signal LEDs can be driven by DIGIO[3:0] signals or signals from the pin header CN8.

The signal LEDs are enabled by the main board configurator.

Table 5.28 shows the signals and the pins which the signal LEDs are connected to.

Figure 5.67 shows circuit diagram for the signal LEDs.

Table 5.28 LED signal connection

LED	Signal name	Connector
LED20	DIGIO[0]	CN8 pin 1
LED21	DIGIO[1]	CN8 pin 2
LED22	DIGIO[2]	CN8 pin 3
LED23	DIGIO[3]	CN8 pin 4

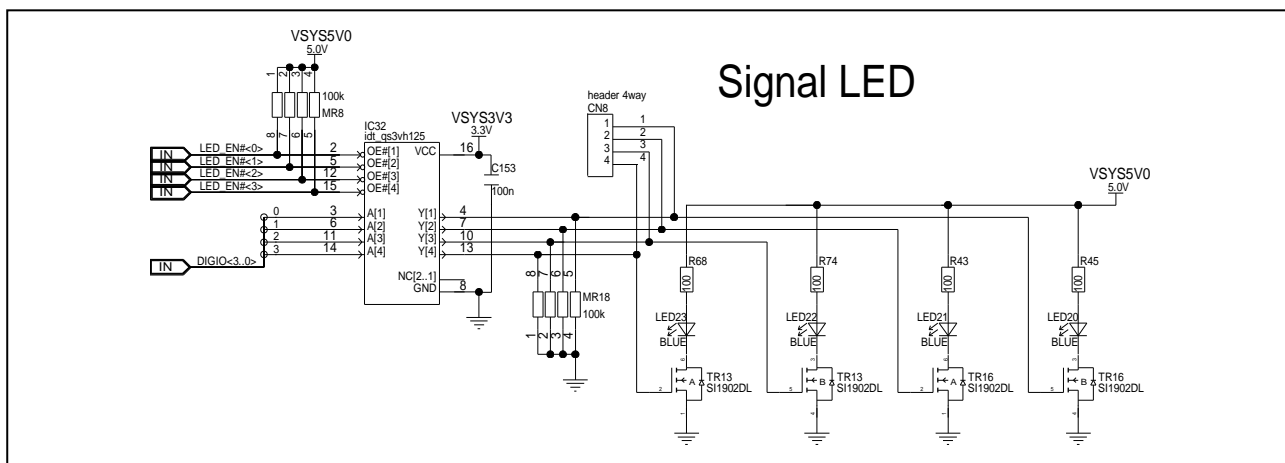

Figure 5.67 Signal LEDs

5.21 I2S Interface

The main board provides two Serial Sound Interfaces (SSIF) on the Pmod™ connectors. For this the main board includes a connector for a module that implements the master clock generation.

Figure 5.68 shows circuit diagram for the clock module connector.

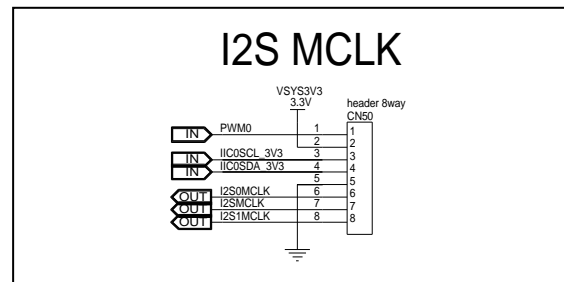

Figure 5.68 Connector for master clock generation

Table 5.29 Connector for master clock generator module

Pin	Signal name	Function
1	PWM0	PWM output from main board to module
2	VSYS3V3	Supply voltage
3	IIC0SCL_3V3	I2C interface to module
4	IIC0SDA_3V3	
5	GND	GND
6	I2S0MCLK	Clock signal from module to PMOD0 pin 9
7	I2SMCLK	Clock signal from module to piggyback connector CN3 pin 19
8	I2S1MCLK	Clock signal from module to PMOD1 pin 9

5.2.2 IIC Level Shifter

The main board has a level shift circuit, which can be used to change the signal level for IIC0 coming from the piggyback board (connectors CN1[23] and CN1[24]). The level shifter is enabled using the main board configurator.

The level shifter takes care that the peripheral circuits on the main board get 5.0V or 3.3V IIC signals depending on their requirements.

Figure 5.69 and Figure 5.70 show the circuit diagrams for the clock module connector. From board version D019712_06_V02 onwards the power supply LED LED16 has been added.

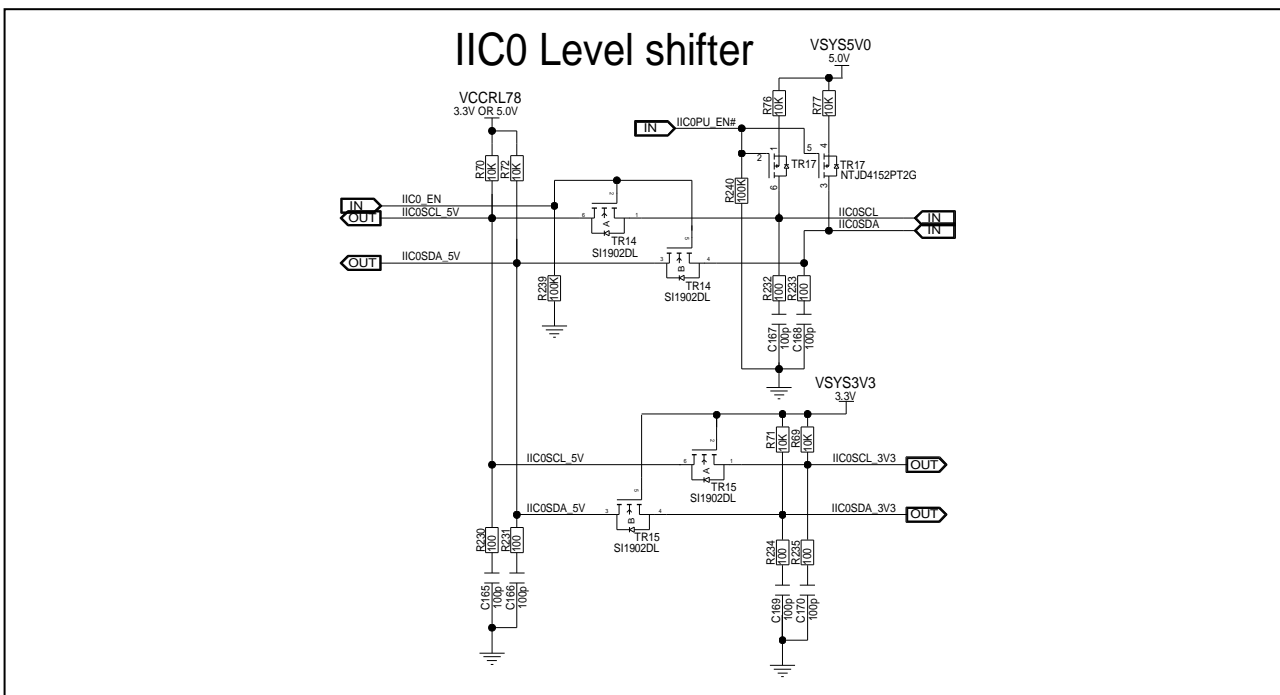

6. Precautions

6.1 Resolver Circuit

The signal quality of the resolver circuit output signal may not be sufficient for the resolver to digital converter in the processor of the connected piggyback board to work properly.

If needed instructions how to rework the main board can be provided separately.

Affected boards: All boards up to version D019712_04_V0202.

Improved boards: Boards from version D019712_04_V0300 onwards.

7. Mechanical Dimensions

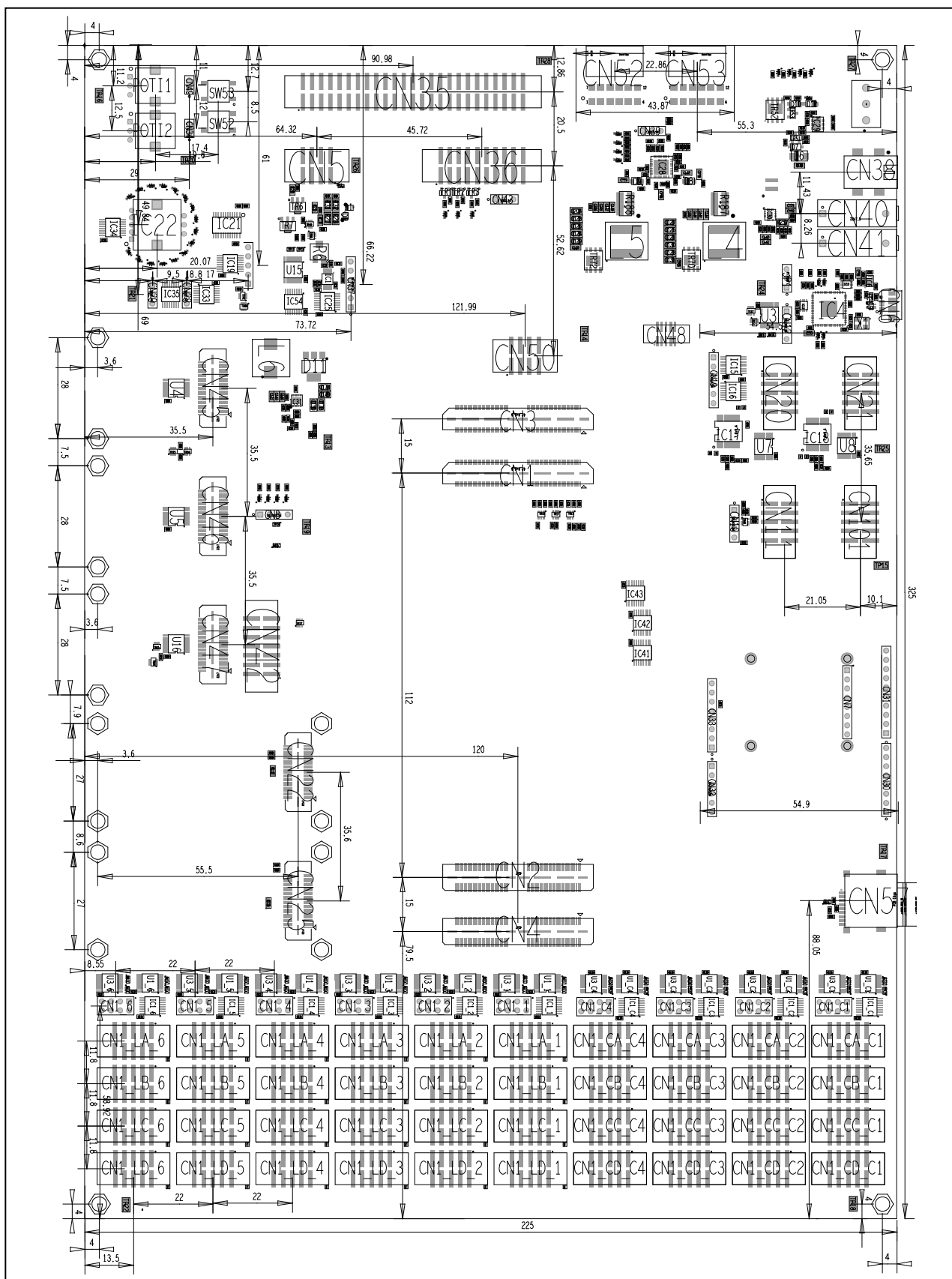

Figure 7.1 Mechanical dimensions of board version D019712_06_V01

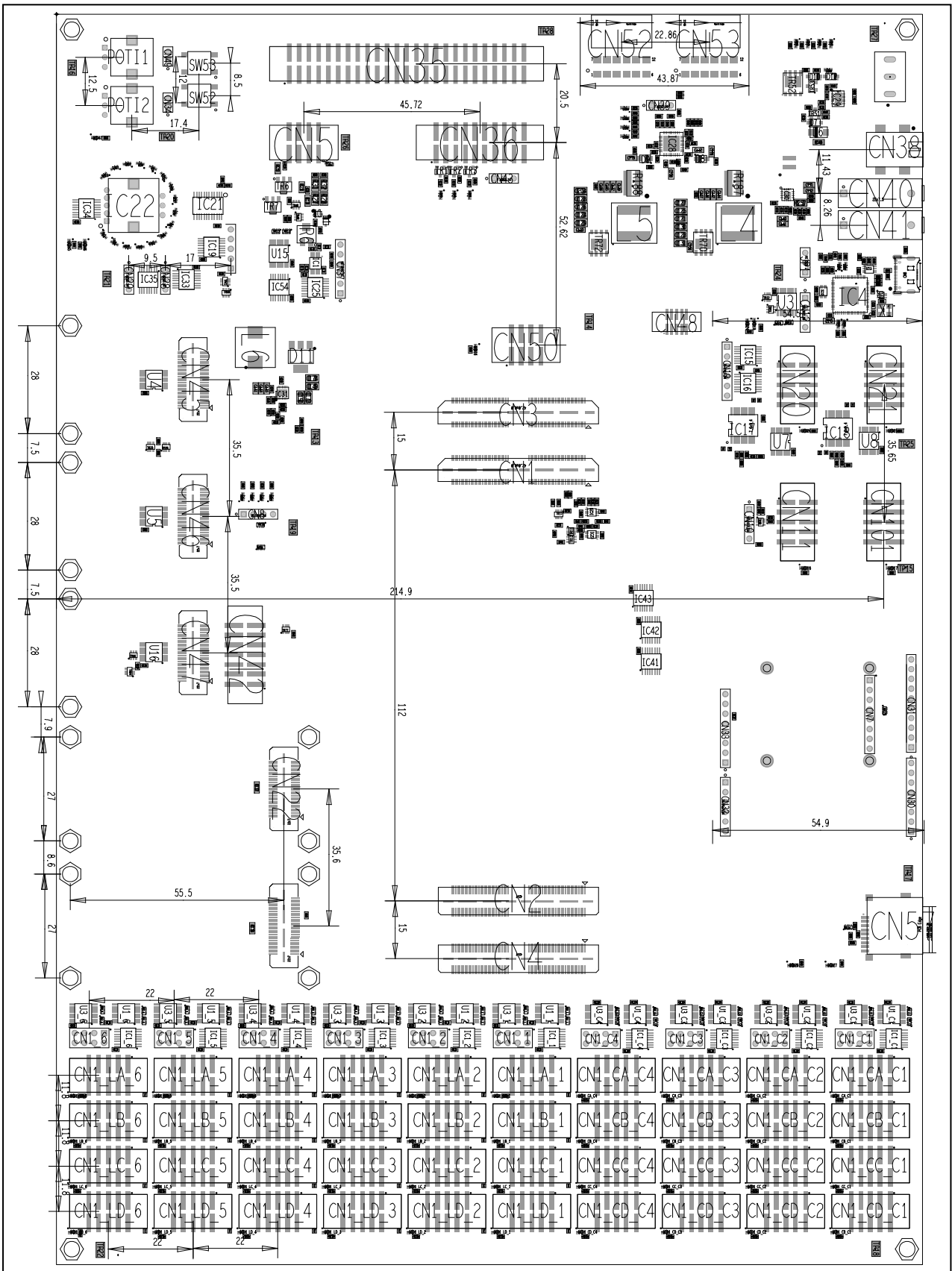

Figure 7.2 Mechanical dimensions of board version D019712_06_V02

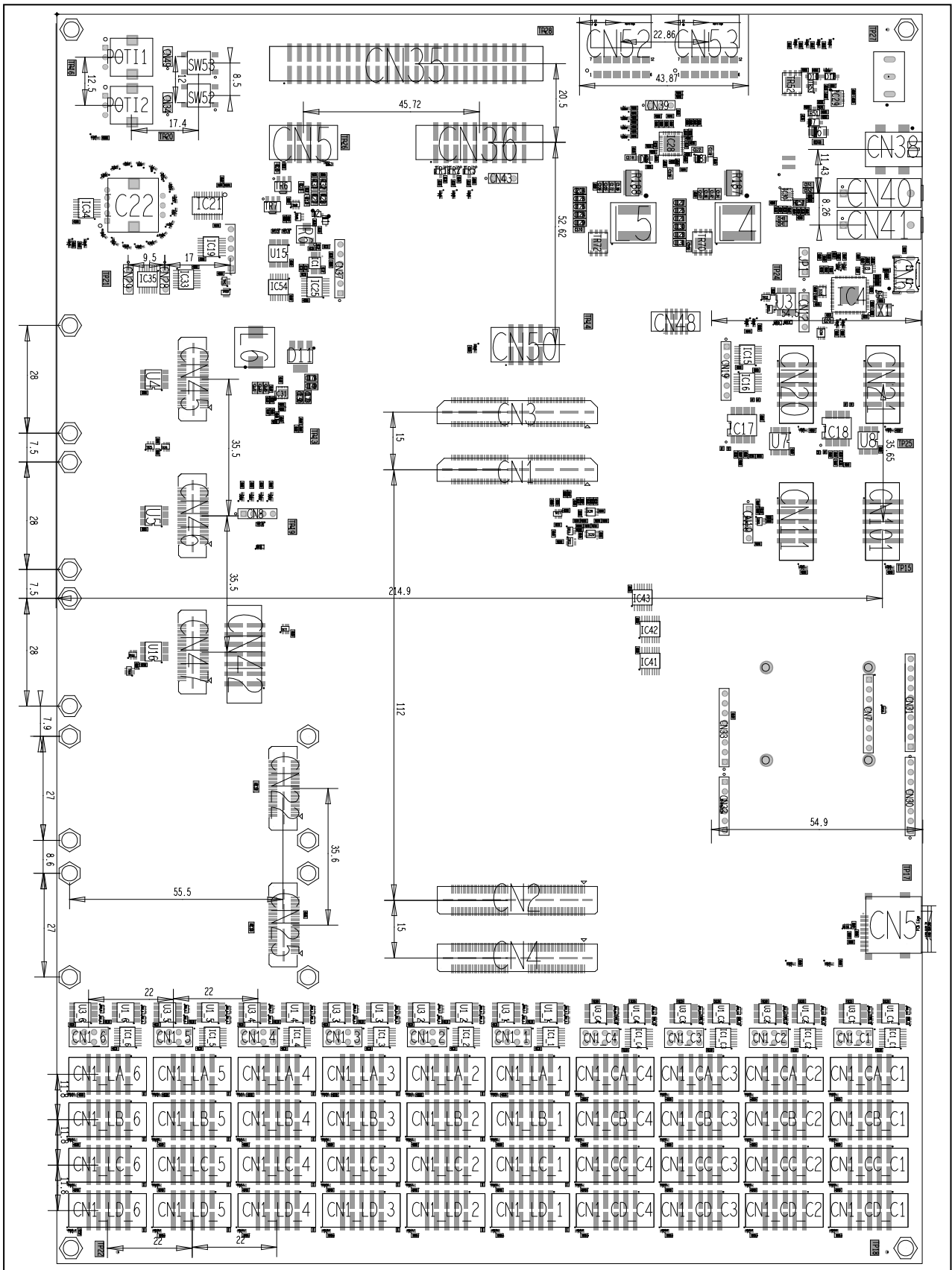

Figure 7.3 Mechanical dimensions of board version D019712_06_V03

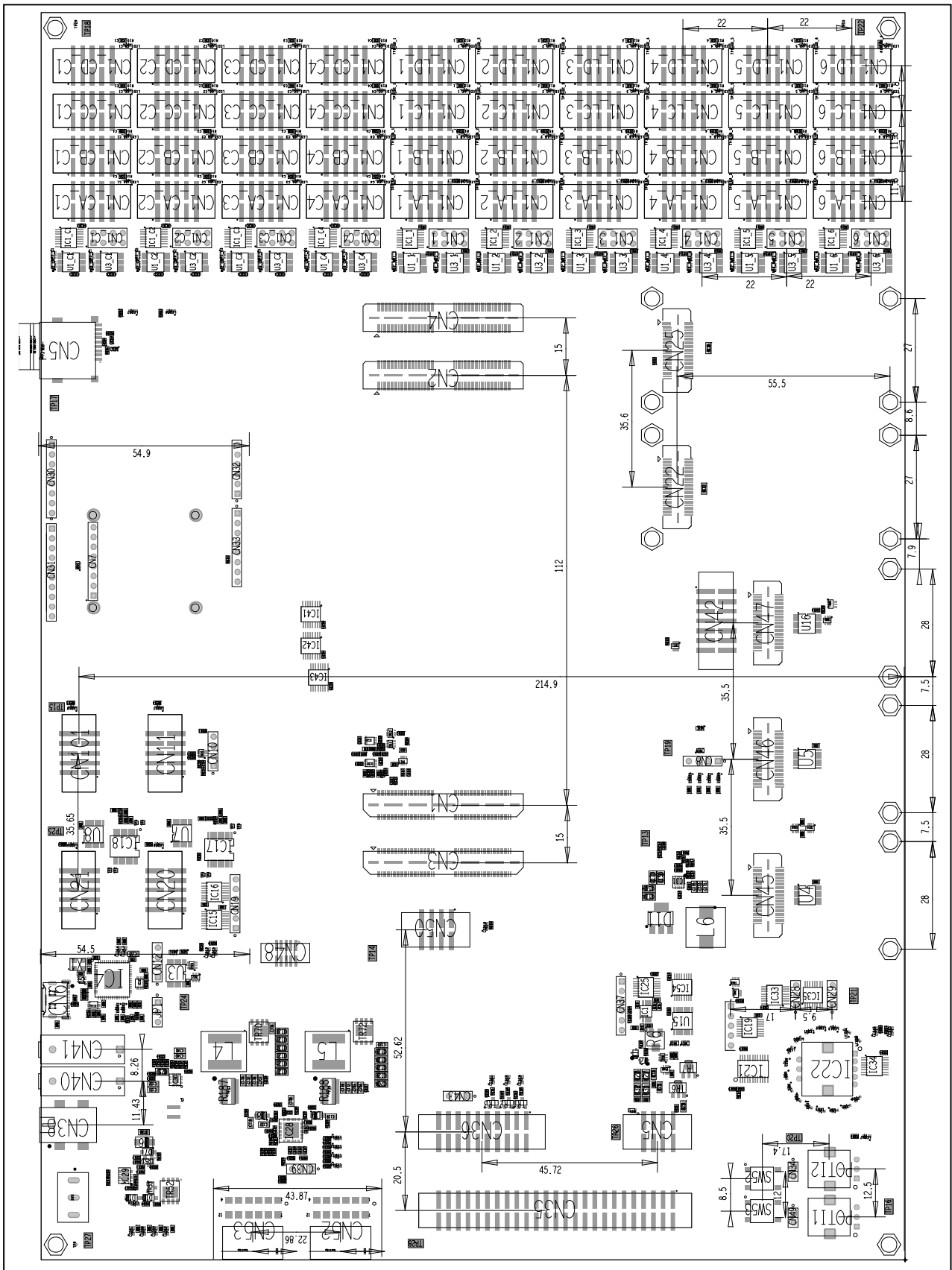

Figure 7.4 Mechanical dimensions of board version D019712_06_V04

8. Schematics

CAUTION

The schematics shown in this document are not intended to be used as a reference for mass production. Any usage in an application design is in sole responsibility of the customer.

The following components described in the schematics of Y-COMMON-MB-T1-V1 are not assembled and are not provided with the board upon delivery:

- Capacitors: C7_1, C7_2, C7_3, C7_4, C7_5, C7_6, C8_1, C8_2, C8_3, C8_4, C8_5, C8_6, C157
- Resistors: R117, R118, R195, R213, R215, R216, R238, R9_LA_1, R9_LA_2, R9_LA_3, R9_LA_4, R9_LA_5, R9_LA_6, R9_LB_1, R9_LB_2, R9_LB_3, R9_LB_4, R9_LB_5, R9_LB_6, R9_LC_1, R9_LC_2, R9_LC_3, R9_LC_4, R9_LC_5, R9_LC_6, R9_LD_1, R9_LD_2, R9_LD_3, R9_LD_4, R9_LD_5, R9_LD_6
- Serial flash memory IC: IC50
- Connector: CN4

The above components are crossed out in the schematics.

The following components described in the schematics are provided with but not mounted on the board upon delivery:

- 1 jumper, 2.54 mm, black

On board version D019712_06_V02 these additional components are not assembled and are not provided with the board upon delivery:

- Resistors: R244, R245, R294, R295, R313, R314
- Connector: CN39

On board version D019712_06_V03 these additional components are not assembled and are not provided with the board upon delivery:

- Capacitors: C71, C72
- Resistors: R244, R245, R313, R314
- Transceiver IC: IC56
- Connector: CN39

The above components are crossed out in the schematics.

Resistors R294 and R295, that were not assembled on board version D019712_06_V02, are again assembled on board version D019172_06_V03 and later.

8.1 Board Version D019712_06_V01

8.1.1 Page 1: Table of Contents

REV	COMMENT	DATE	DRAWN BY
1.0	Initial Release	18.07.2023	WR
1.04	D019712_04_S03_V0104_y_common_mb_t1_v1_RevisionHistory.txt	14.11.2023	FR
1.05	D019712_04_S03_V0105_y_common_mb_t1_v1_RevisionHistory.txt	05.12.2023	FR

Table of Contents	
Page No.	Page Name
1	Table of Contents
2	Power Supply
3	Voltage-/Signal LED's / IIC0 / Board Configuration
4	LIN / SENT
5	UART
6	CAN (XL)
7	FlexRay
8	Ethernet / SD-SFMA / I2S
9	Encoder / LED CSI-Driver
10	Display / Interrupt / A/D Measurement
11	Resolver
12	Motor
13	PMOD
14	Piggyback Board Connectors / Multiplexer
15	LIN Transceiver X4
16	LIN Transceiver
17	CAN Transceiver X4
18	CAN Transceiver

	
Title Y-RH850-X2X-MB-T1-V2	
Size	Document Number
A3	D019712_04_V2
Date	Type Dec 5 15:57:46 2023
PAGE 1 OF 18 V1.05	

8.1.2 Page 2: Power Supply

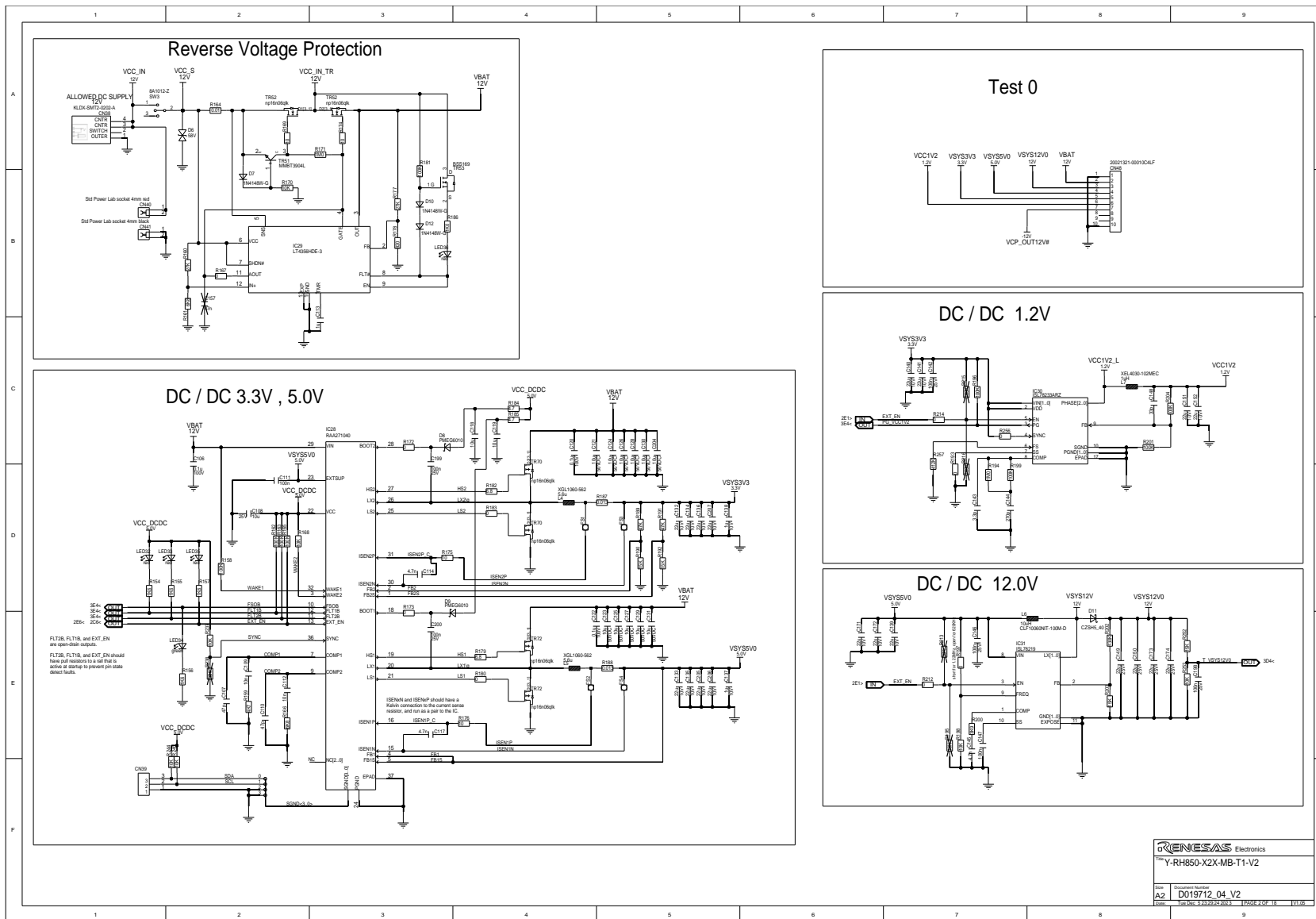

8.1.3 Page 3: Voltage-/Signal LEDs / IIC0 / Board Configurator

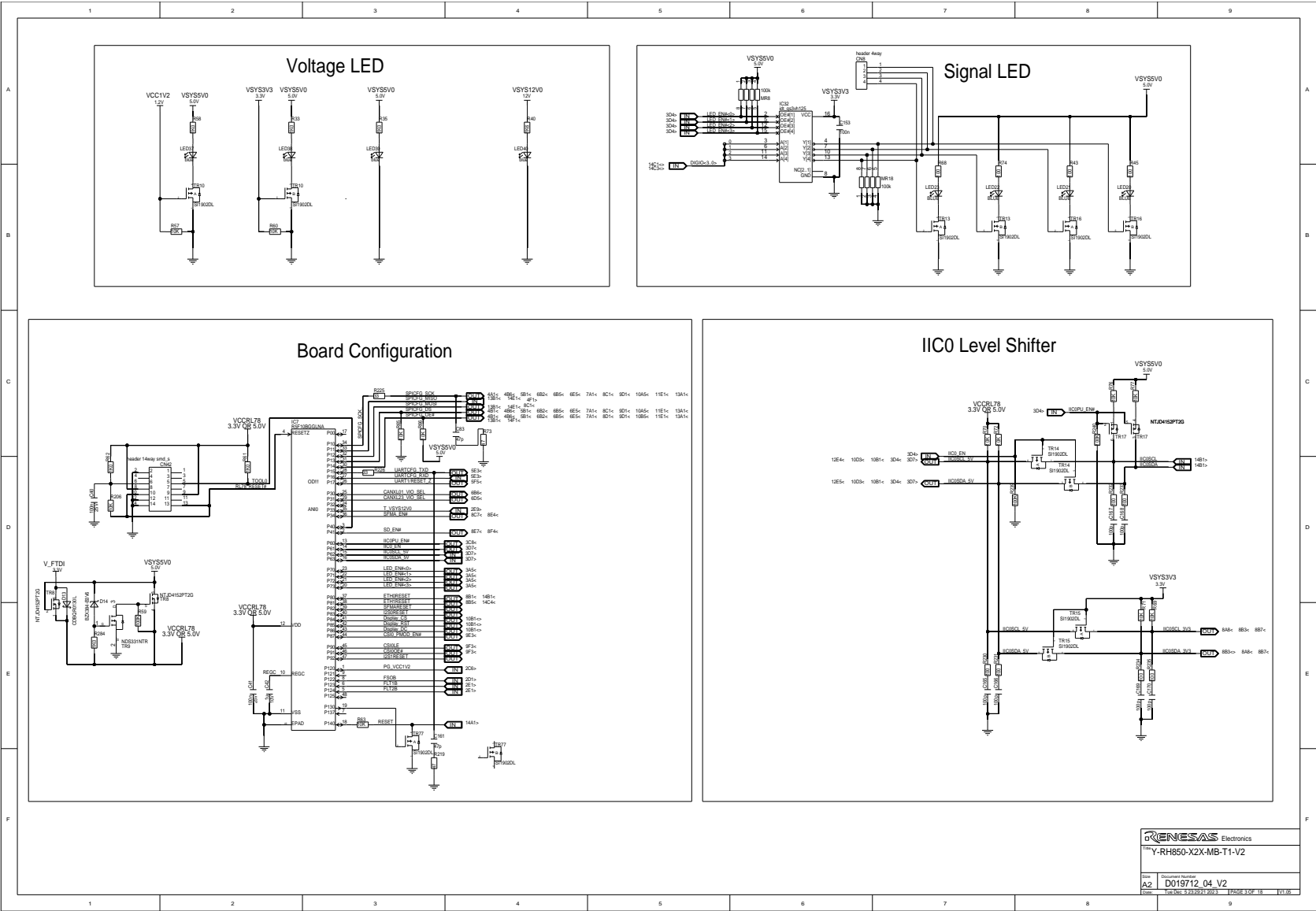

8.1.4 Page 4: LIN / SENT Interfaces

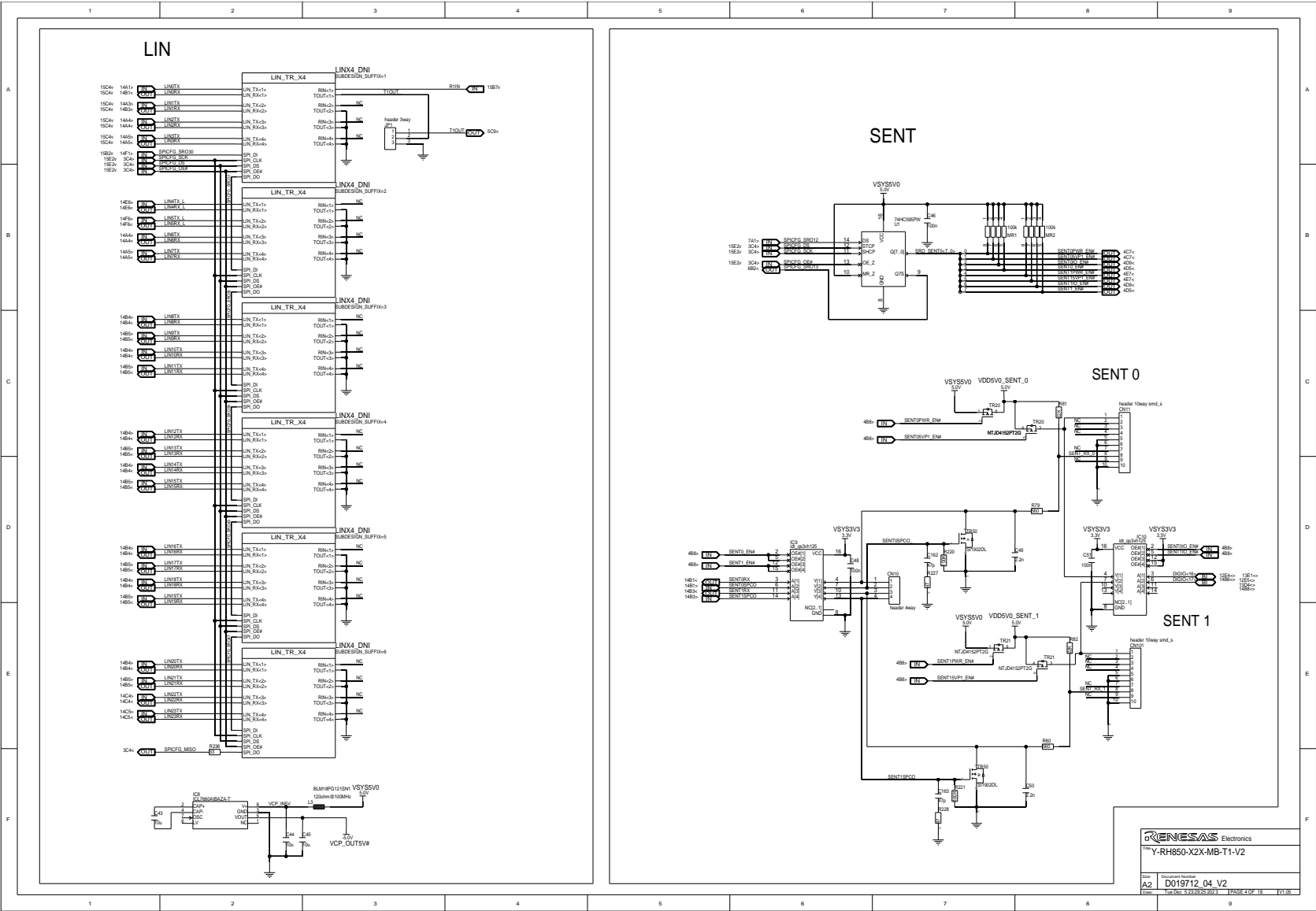

Y-RH850-X2X-MB-T1-V2	
Doc. No.	Document Number
A.2	D019712.04_V2
Rev.	1st Ed. 5/23/2020 (2020) 1/2021 (Rev. 11)

8.1.5 Page 5: UART Interfaces

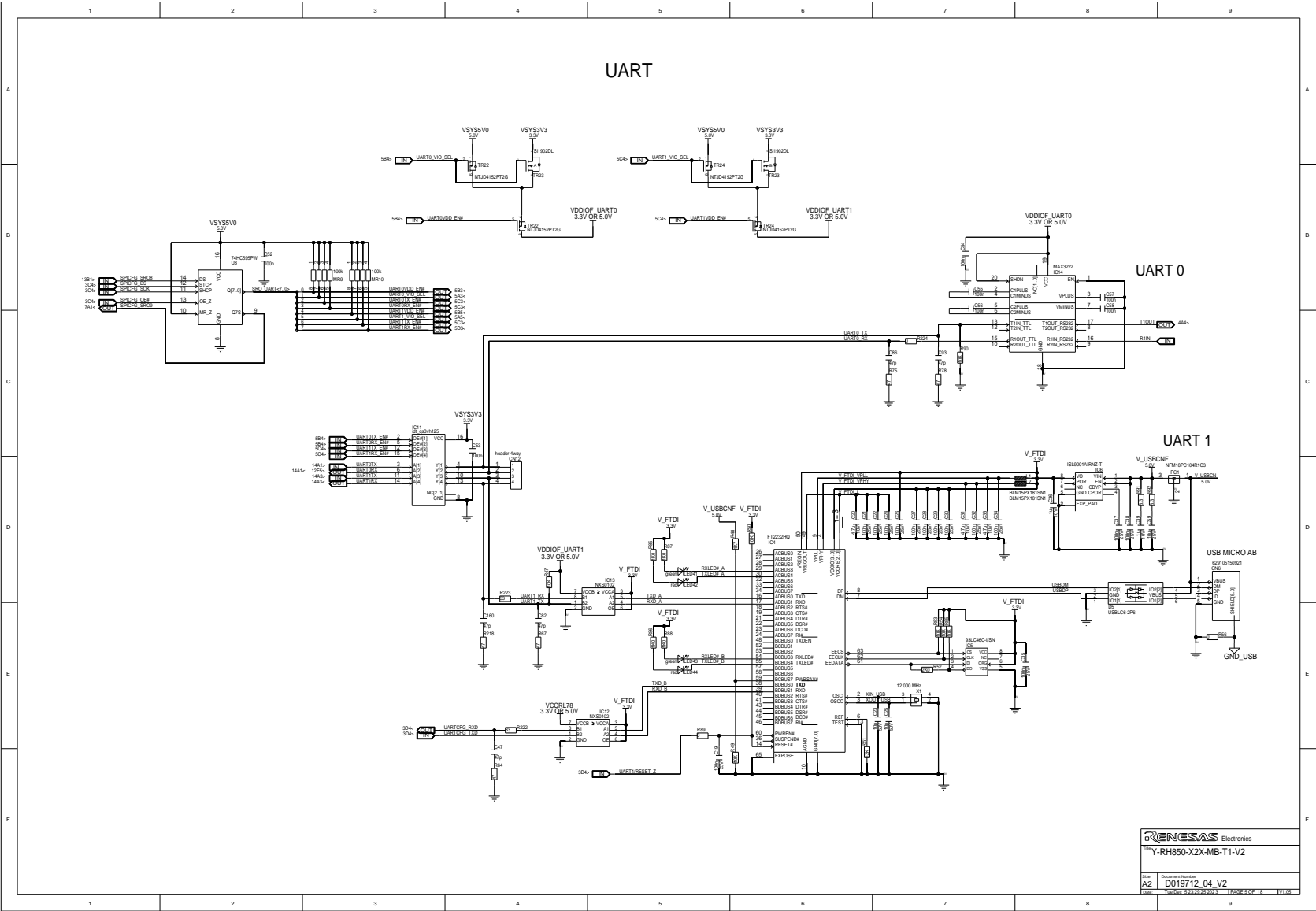

Y-RH850-X2X-MB-T1-V2	
Date: A2	Document Number: D019712_04_V2
Ver: 1.00	(Rev. Ver. 5/21/2020/2021) (PAGE 5 OF 18) (10/36)

8.1.6 Page 6: CAN (XL) Interfaces

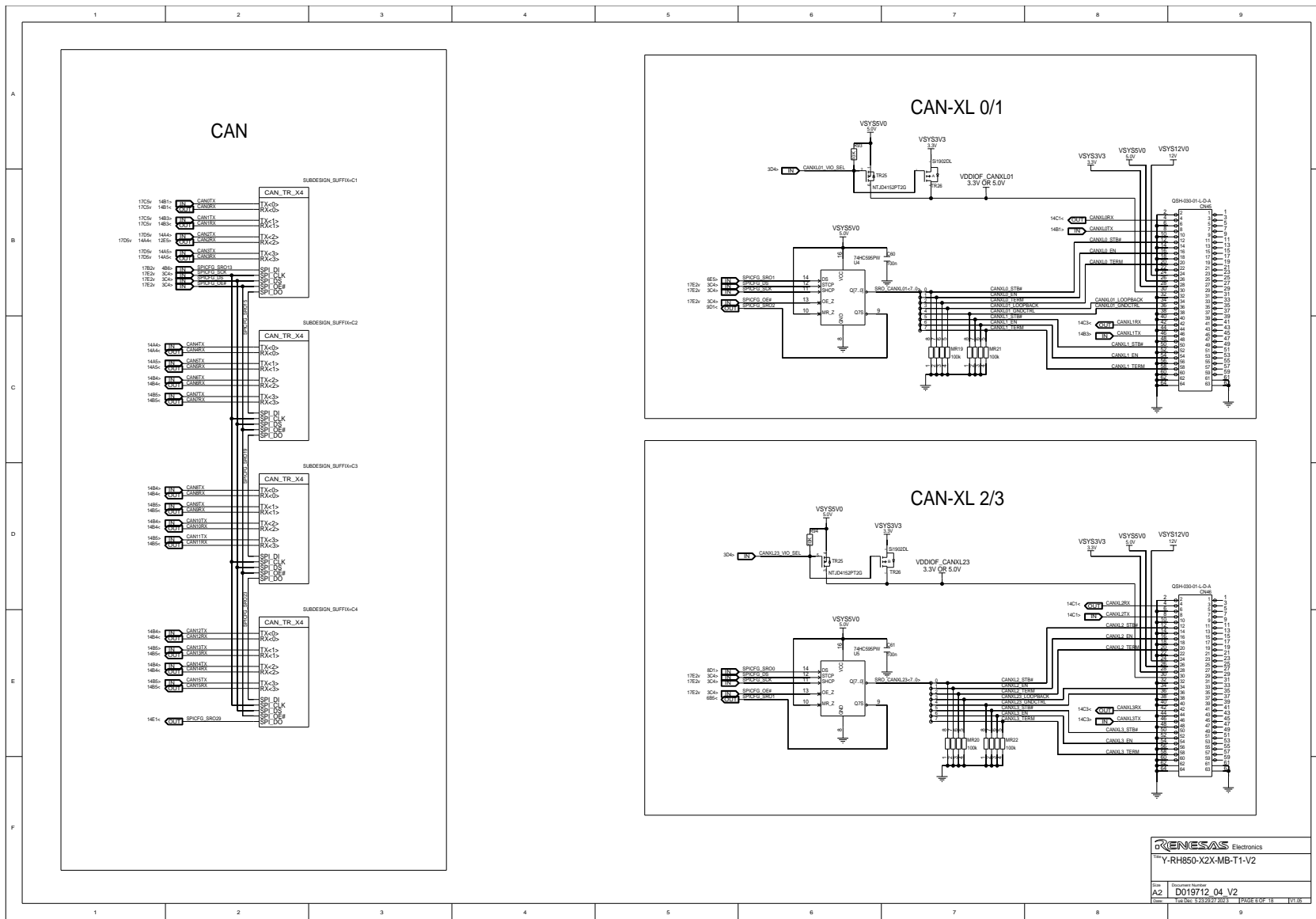

Y-RH850-X2X-MB-T1-V2	
Date:	Document Number:
A2	D019712_04_V2
Date:	(Use Date: 5/23/2027 20:21)
1/2027 EDR: 18	1/10/26

8.1.7 Page 7: FlexRay Interfaces

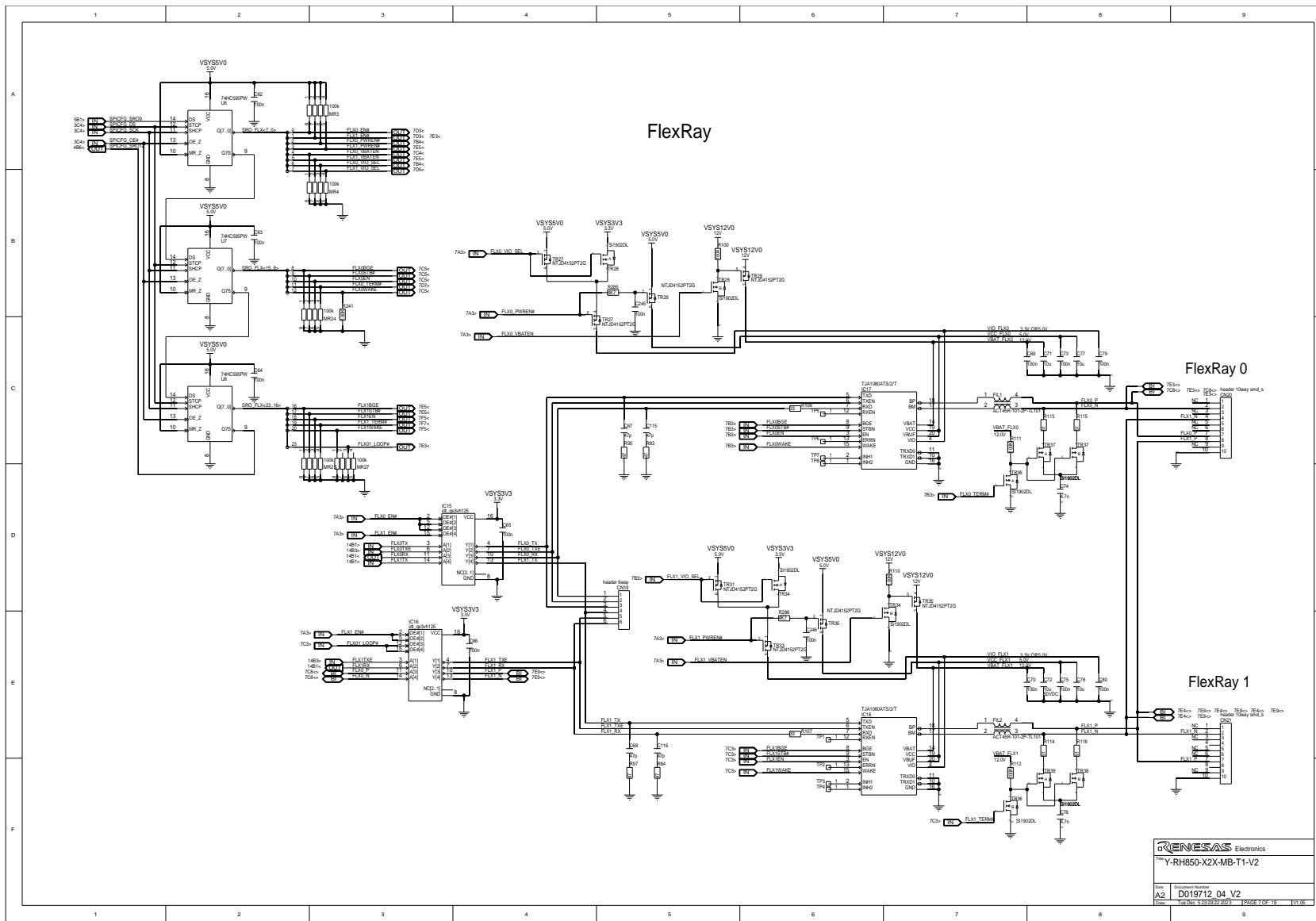

Y-RH850-X2X-MB-T1-V2	
Rev.	Document Number
A.2	D019712_04_V2
Date	(1st Ed.) 5/23/2022 (2021) 1 Page 7 of 18 (10/26)

8.1.8 Page 8: Ethernet / SD Card / SFMA / I2S

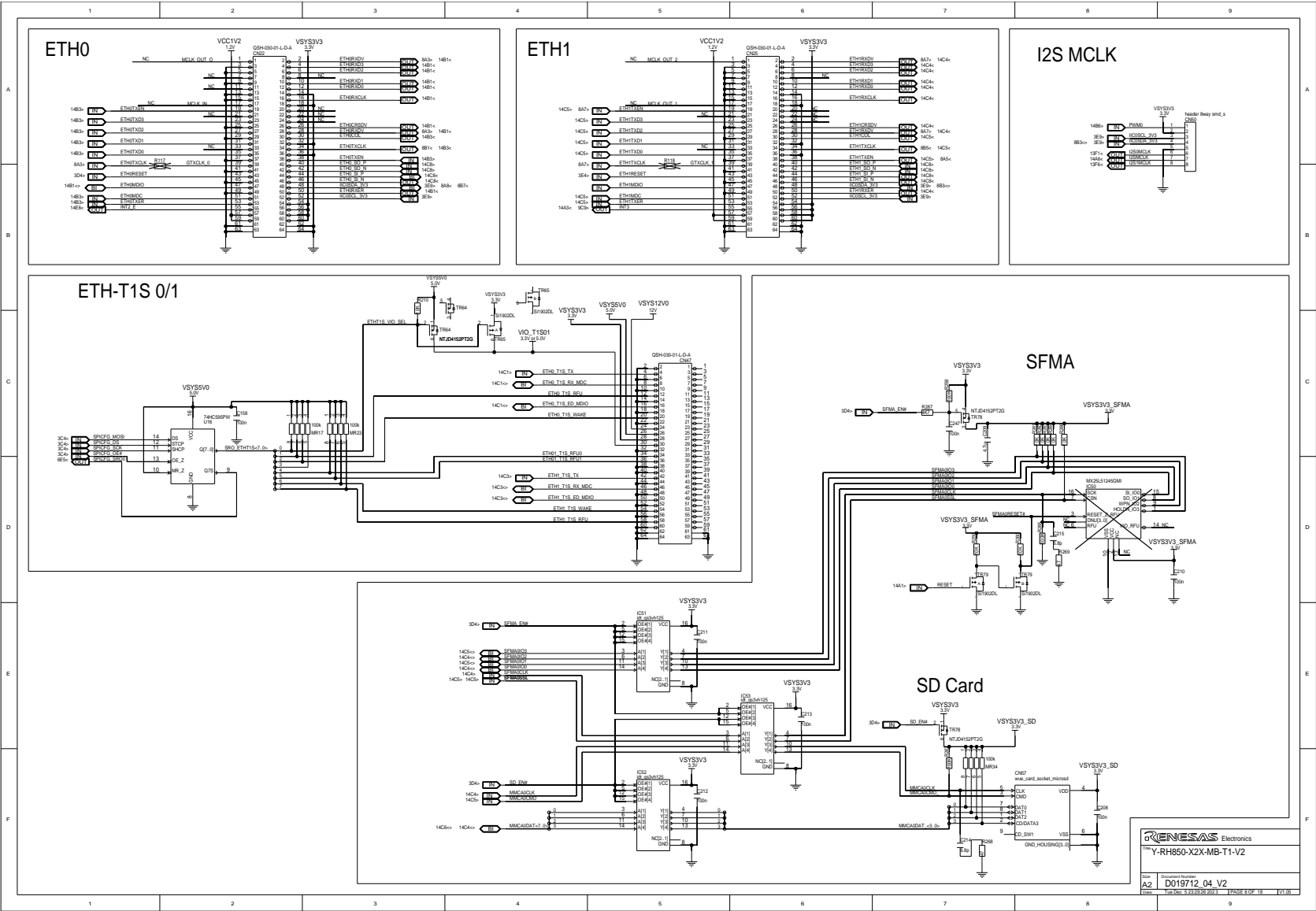

RENESAS Electronics
 Y-RH850-X2M-MB-T1-V2
 Doc. No. D01972.04 V2
 (Rev. Ver. 5.21.2020.2021) PAGE 8 OF 18

8.1.9 Page 9: Encoder / LED CSI-Driver

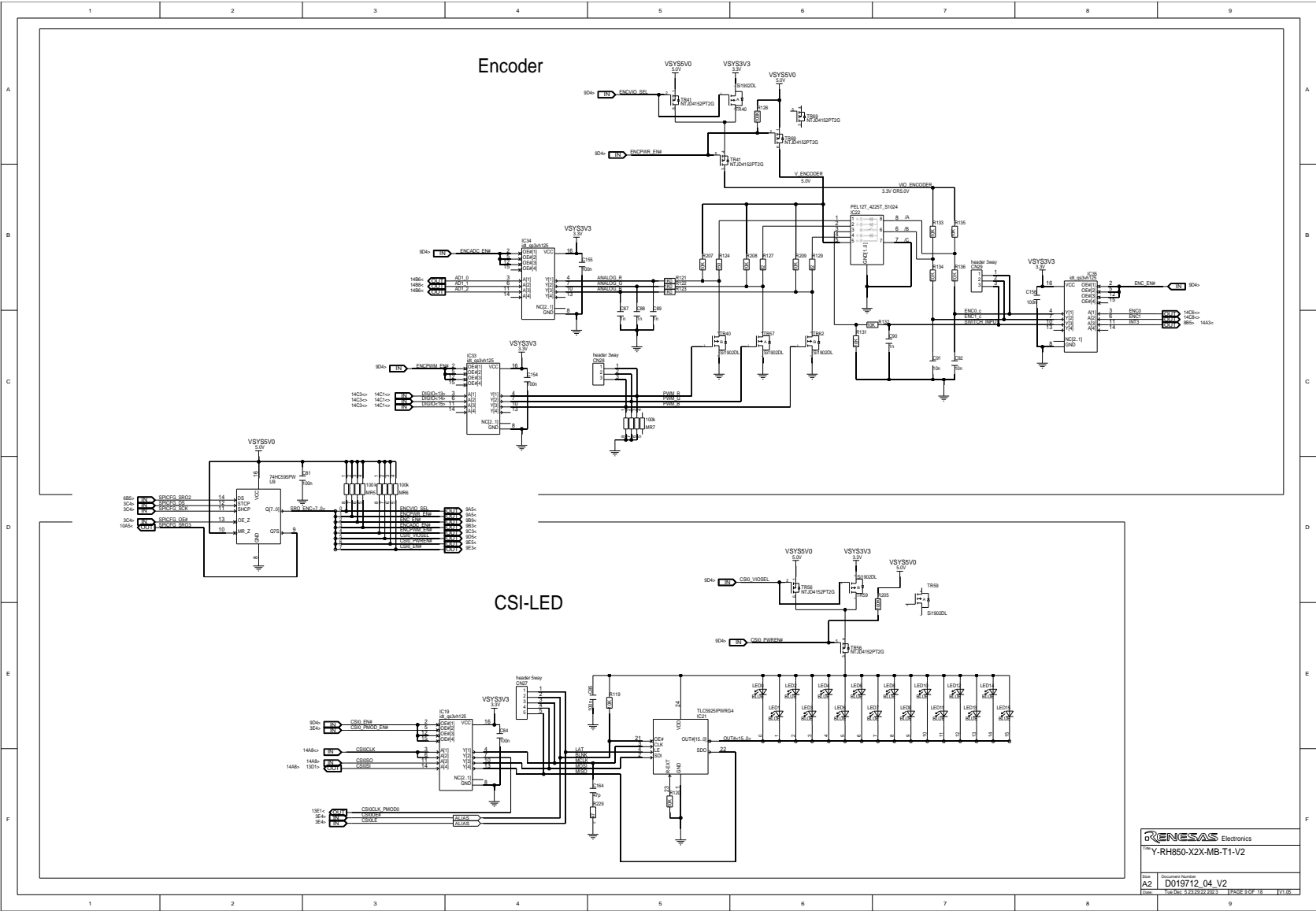

Renesas Electronics
 Y-RH850-X2X-MB-T1-V2
 Doc. No. D01972_04_V2
 Date: 2022.05.11

8.1.10 Page 10: Display / Interrupt / A/D Measurement

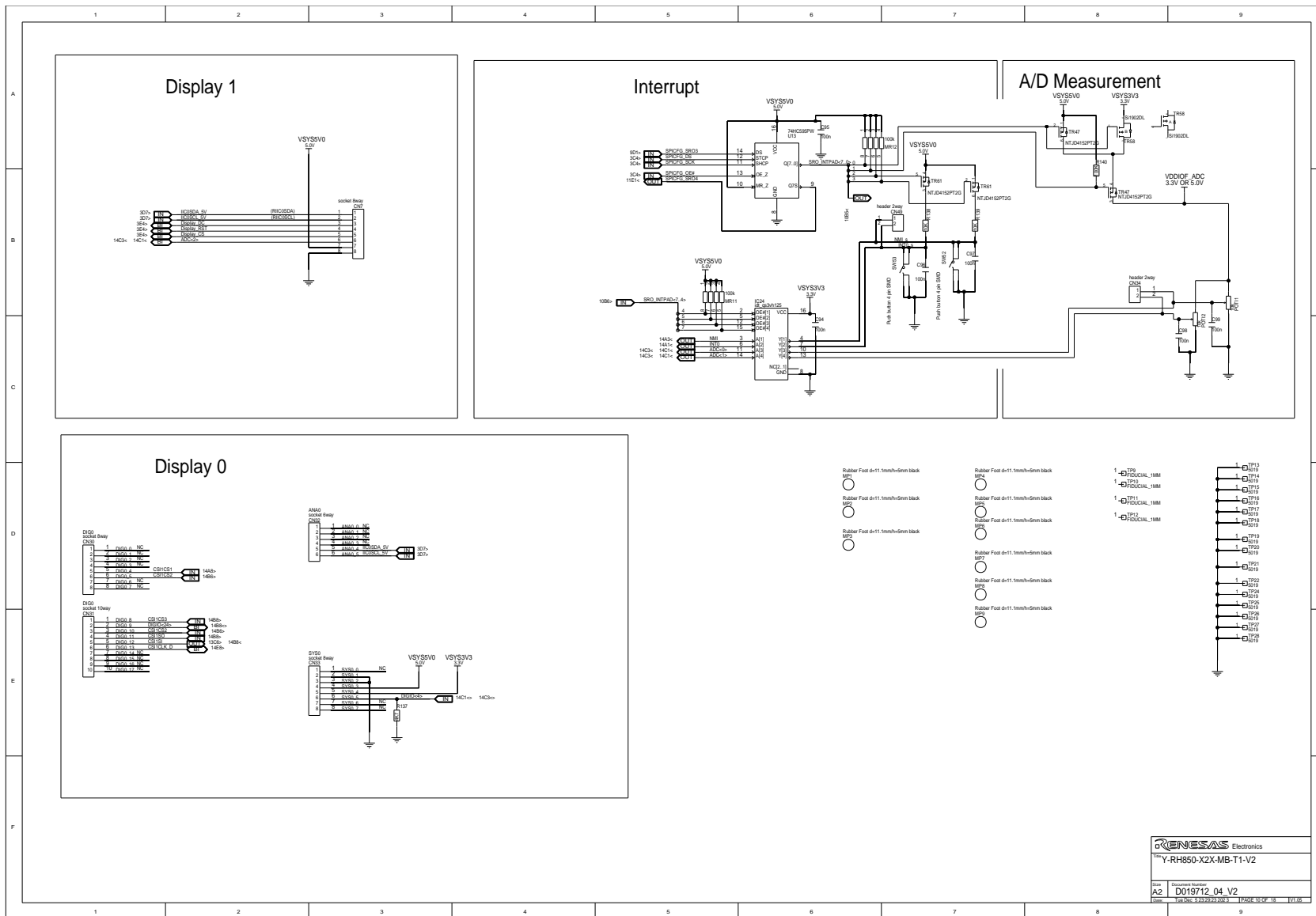

8.1.12 Page 12: Motor

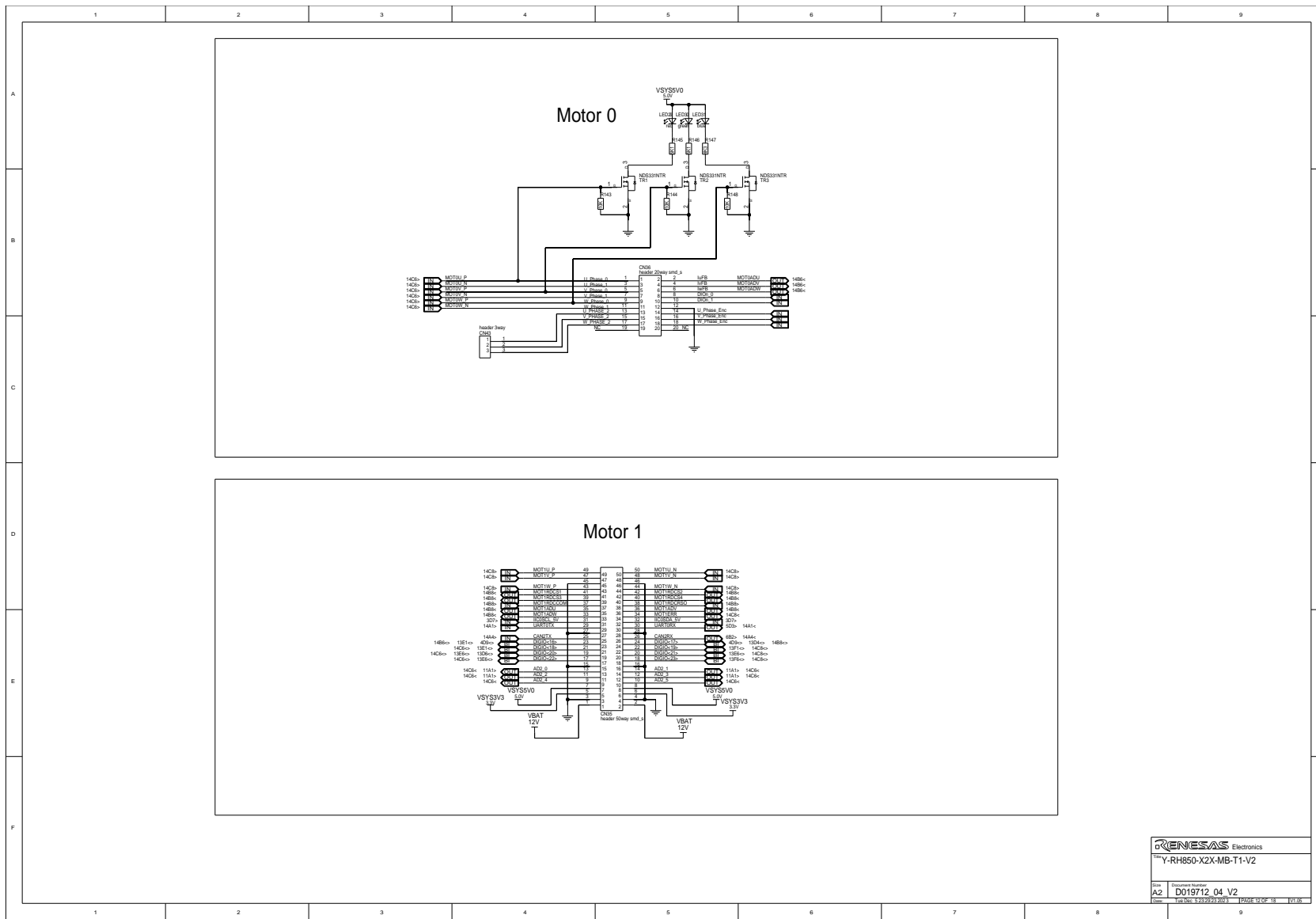

Y-RH850-X2X-MB-T1-V2	
Date:	Document Number:
A2	D019712_04_V2
Date:	(Use Date: 5/27/2021) 1/20th of 11 10/26

8.1.13 Page 13: Pmod™ Interfaces

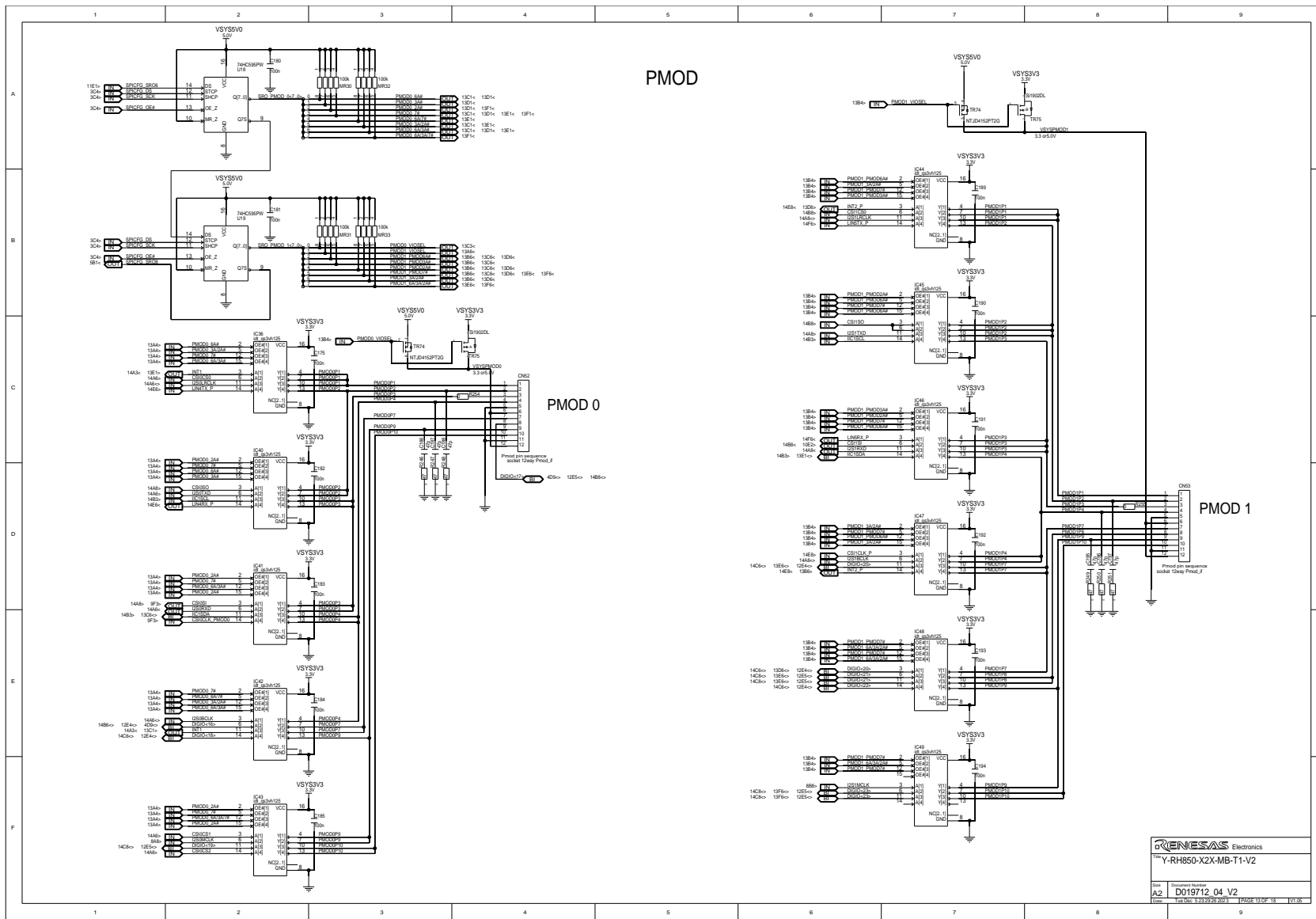

Y-RH850-X2X-MB-T1-V2	
Doc. No.	D019712_04_V2
Doc. Date	2022/02/25
Page No.	11 of 11

8.1.14 Page 14: Piggyback Board Connectors / Multiplexer

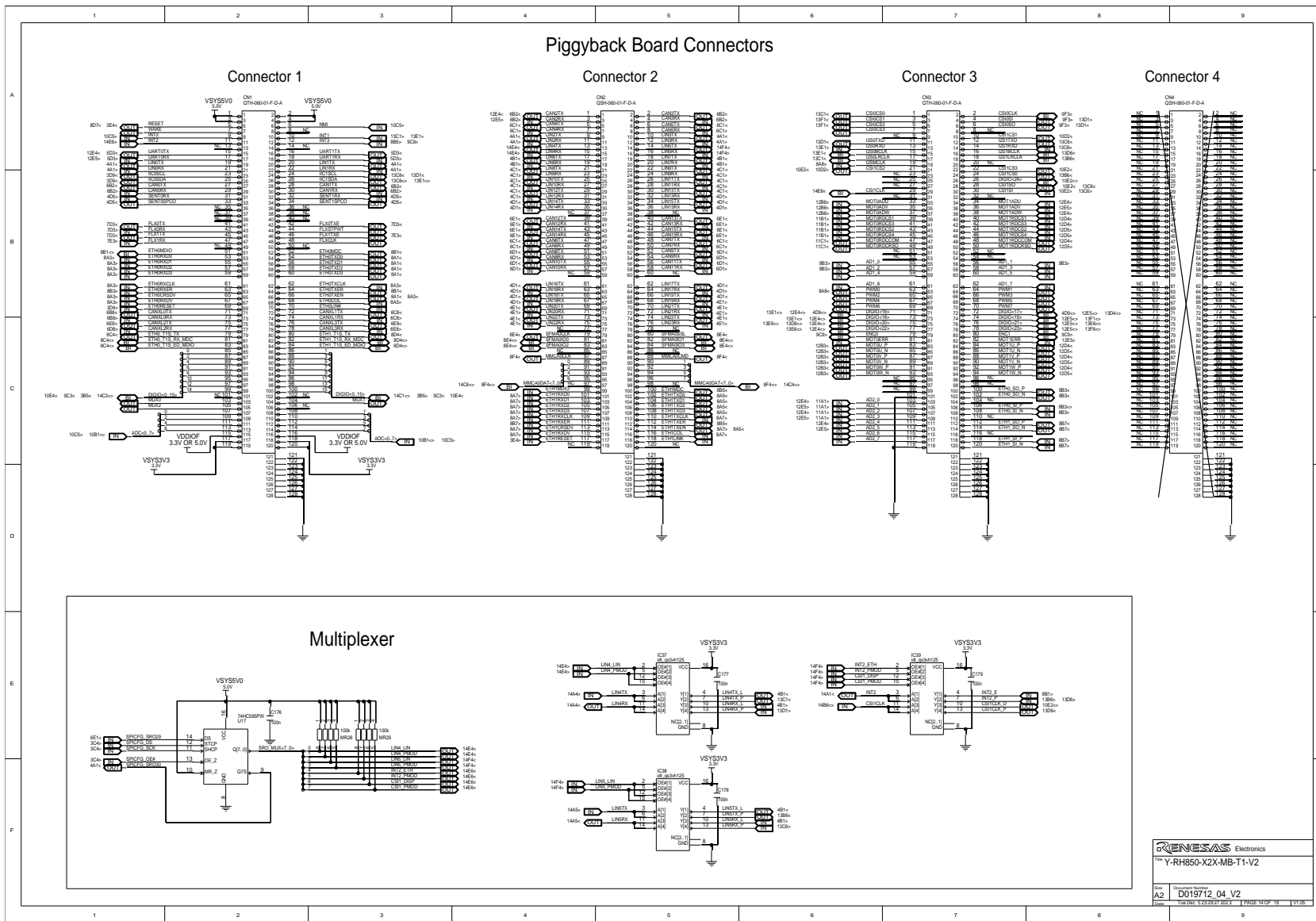

RENESAS Electronics
 Y-RH850-X2X-MB-T1-V2
 Doc. No. D01972.04_V2
 Date: 2022.02.23 1/16

8.1.15 Page 15: LIN Transceiver X4

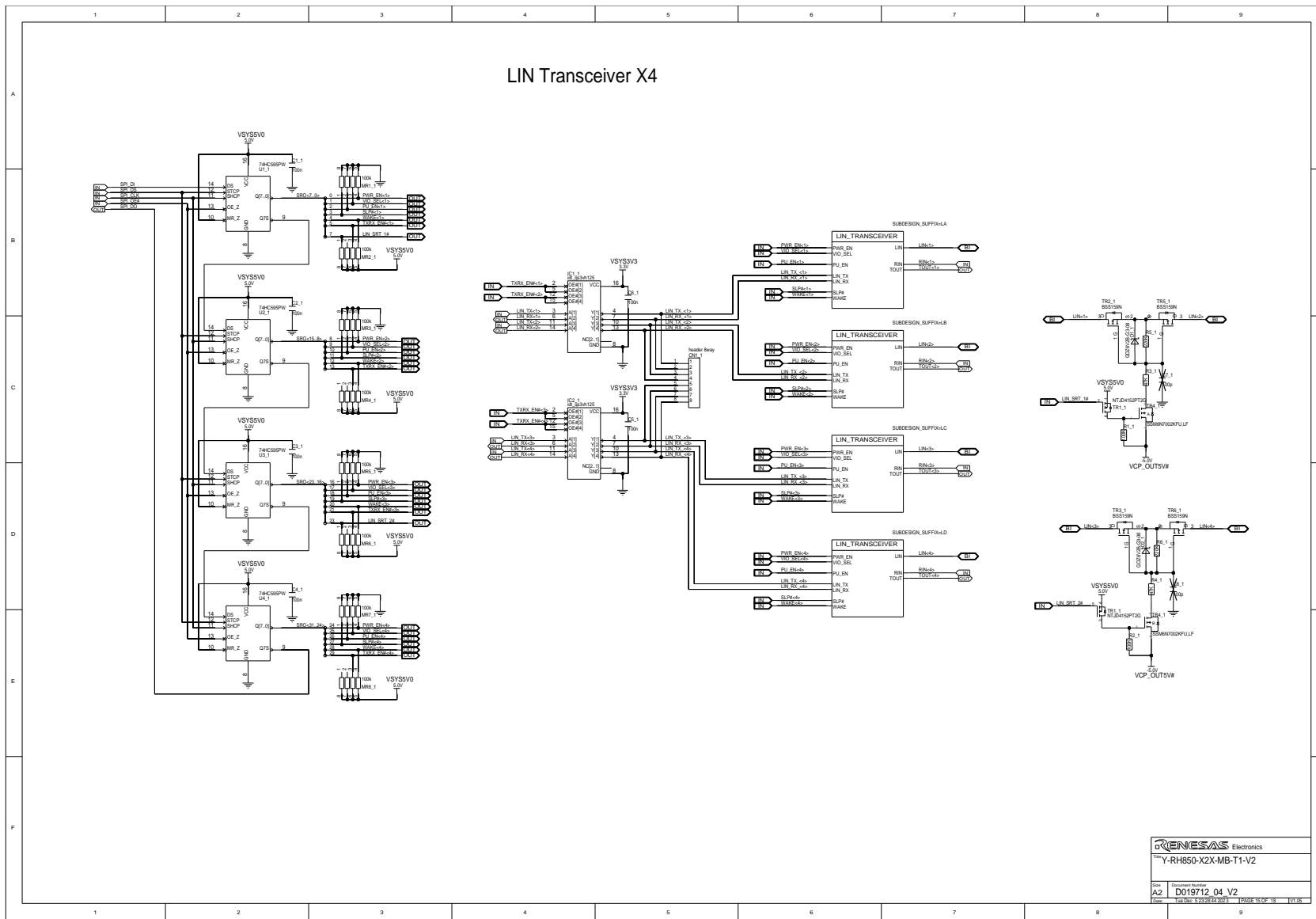

8.1.16 Page 16: LIN Transceiver

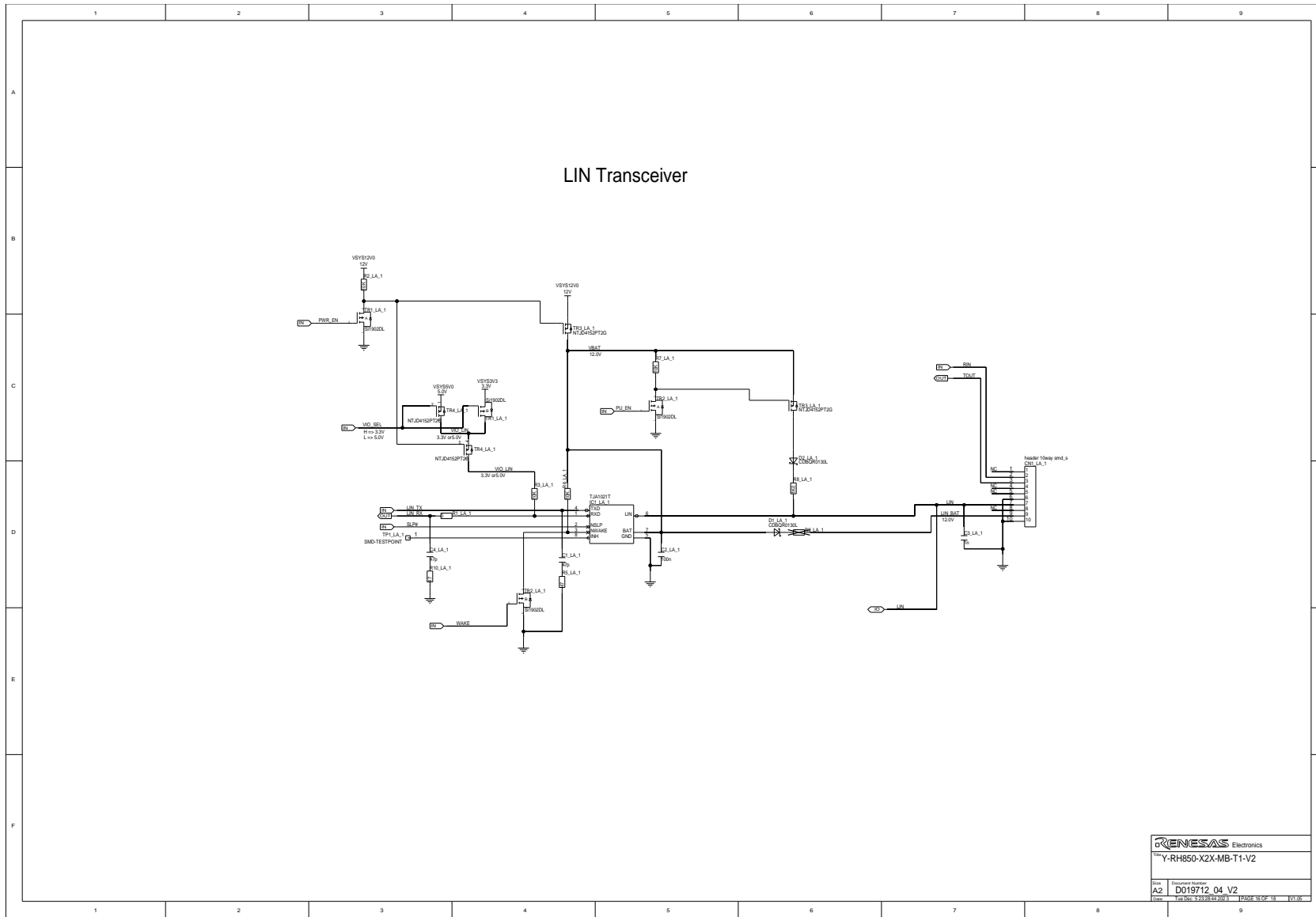

RENESAS Electronics	
Y-RH850-X2X-MB-T1-V2	
Doc. No.	Document Number
A2	D019712 04 V2
Date	Iss. Date: 2022/01/20
	1 PAGE 16 OF 11

8.1.18 Page 18: CAN Transceiver

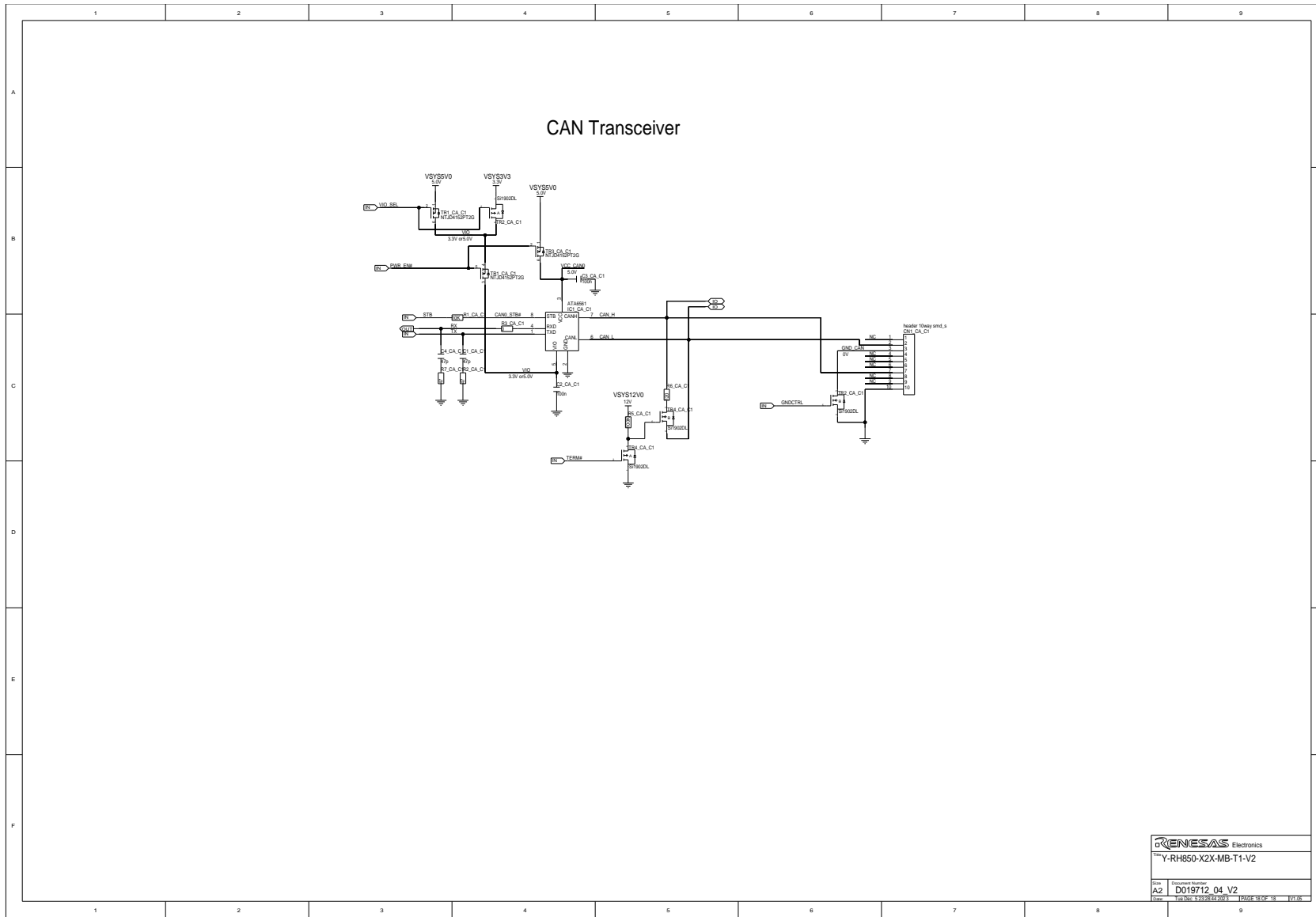

RENESAS Electronics	
Y-RH850-X2X-MB-T1-V2	
Doc. No.	Document Number
A2	D019712_04_V2
Date	1st Ed. 5/27/2021 1/2021 18 of 11 1/1/20

8.2 Board Version D019712_06_V02

8.2.1 Page 1: Table of Contents

REV	COMMENT	DATE	DRAWN BY
1.0	Initial Release	22.02.2024	FR
1.04	D019712_04_S03_V0104_y_common_mb_t1_v1_RevisionHistory.txt	14.11.2023	FR
1.05	D019712_04_S03_V0105_y_common_mb_t1_v1_RevisionHistory.txt	05.12.2023	FR
2.00	D019712_04_S03_V0200_y_common_mb_t1_v1_RevisionHistory.txt	06.12.2023	FR/LS
2.02	D019712_04_S03_V0202_y_common_mb_t1_v1_RevisionHistory.txt	22.02.2024	FR/LS/ME

Page No.	Page Name
1	Table of Contents
2	Power Supply
3	Voltage-/Signal LEDs / IIC0 / Board Configurator
4	LIN / SENT Interface
5	UART Interface
6	CAN (XL) Interface
7	FlexRay Interface
8	Ethernet / SD Card / SFMA / I2S Interface
9	Encoder / LED CSI Driver
10	Display/ Interrupt/ A/D Measurement
11	Resolver
12	Motor
13	PMOD Interface
14	Piggyback Connectors / Multiplexer
15	LIN Transceiver X4
16	LIN Transceiver
17	CAN Transceiver X4
18	CAN Transceiver

RENESAS Electronics	
Title Y-COMMON-MB-T1-V1	
Size A3	Document Number D019712_04_V2
Date: Fri Feb 23 19:23:17 2024	PAGE 1 OF 18 V2.02

8.2.2 Page 2: Power Supply

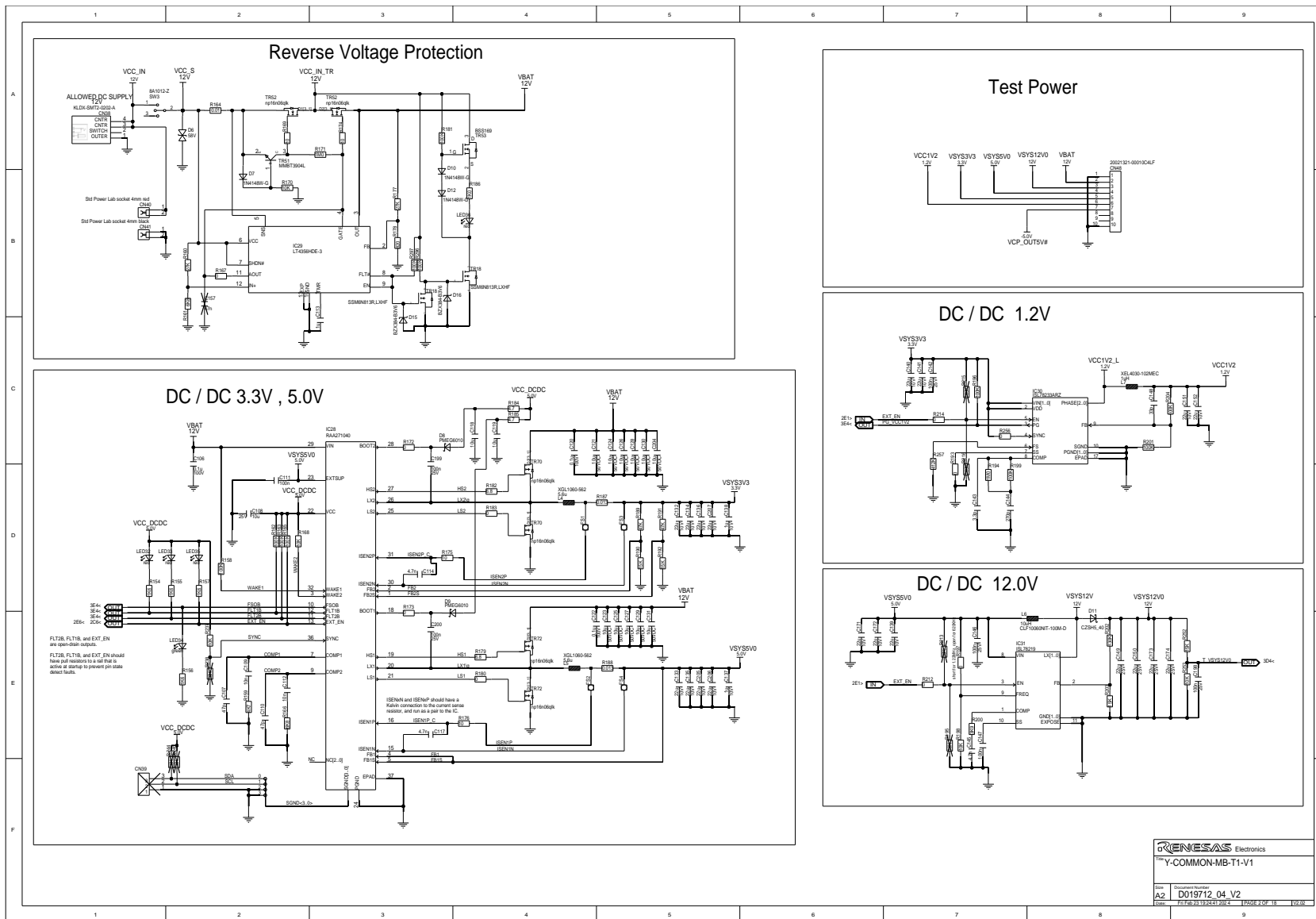

8.2.3 Page 3: Voltage-/Signal LEDs / IIC0 / Board Configurator

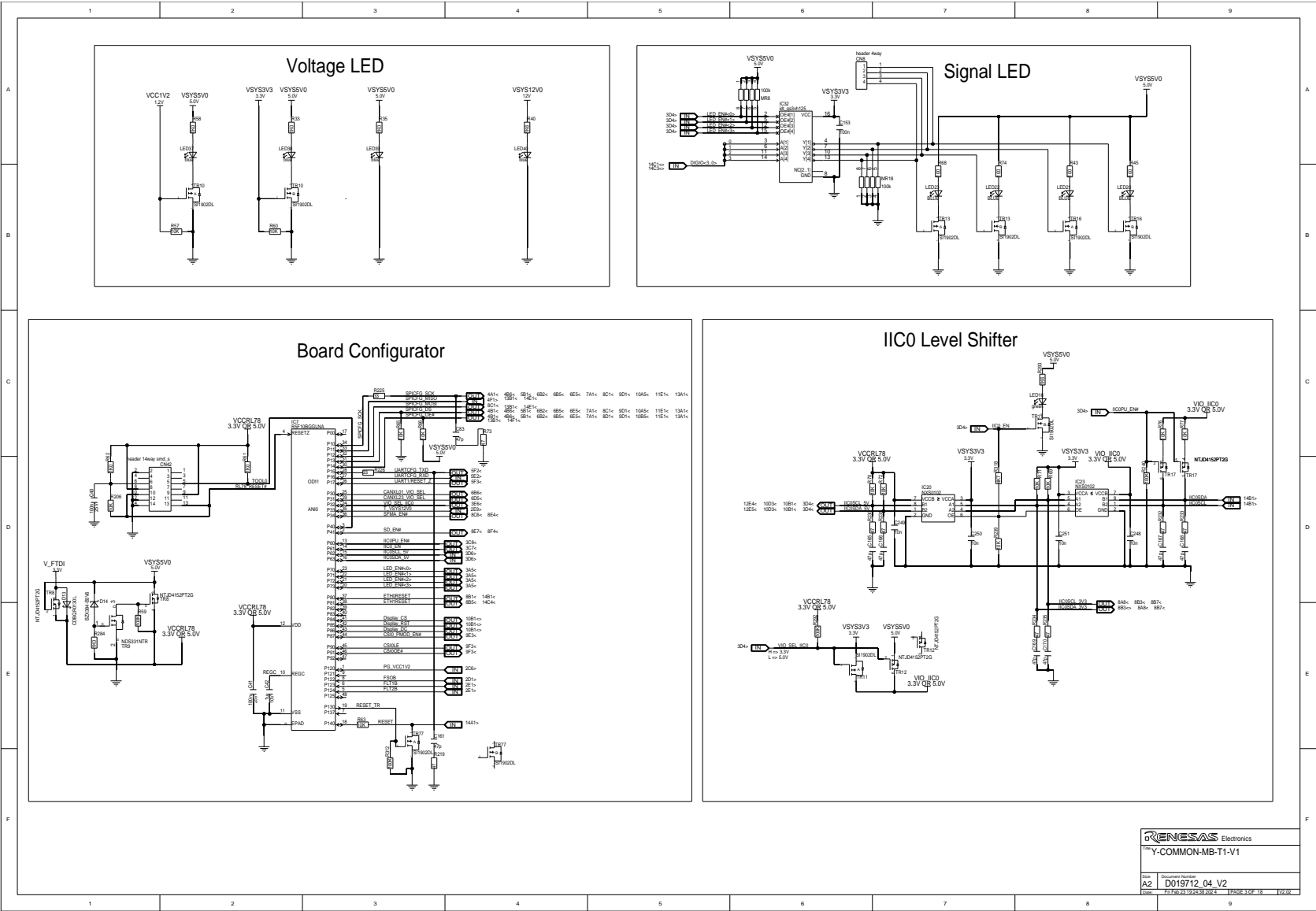

8.2.4 Page 4: LIN / SENT Interfaces

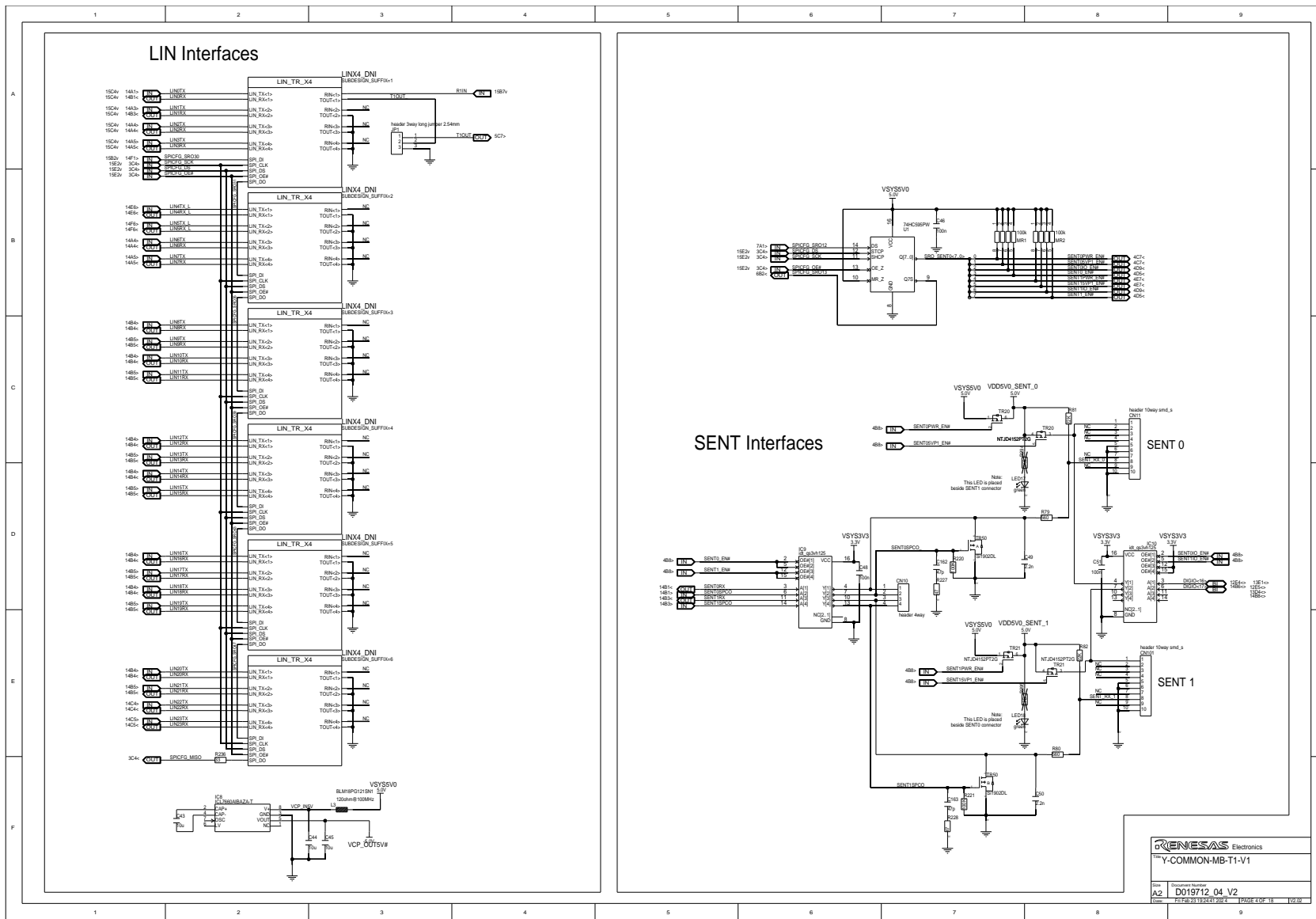

Y-COMMON-MB-T1-V1	
Doc. No.	Document Number
A.2	D01972.04 V2
Rev.	Rev. 23.10.24.1.00.2
Doc. No.	Doc. No. 11

8.2.6 Page 6: CAN (XL) Interfaces

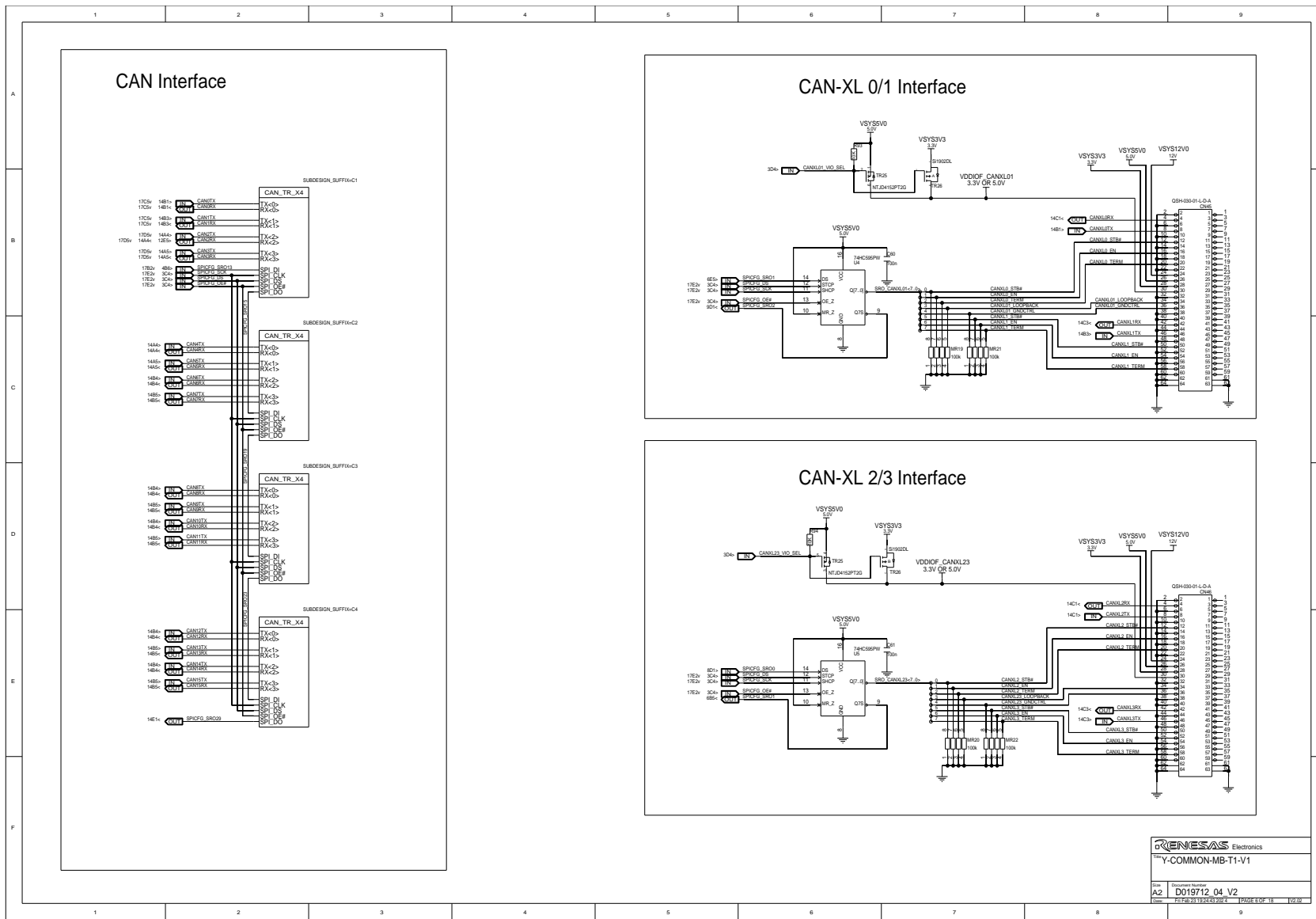

Y-COMMON-MB-T1-V1

 Date: _____ Document Number:

 A2 D01972 04 V2

 Date: 19 Feb 23 10:24:03 UTC Page: 6 of 18 10/26

8.2.7 Page 7: FlexRay Interfaces

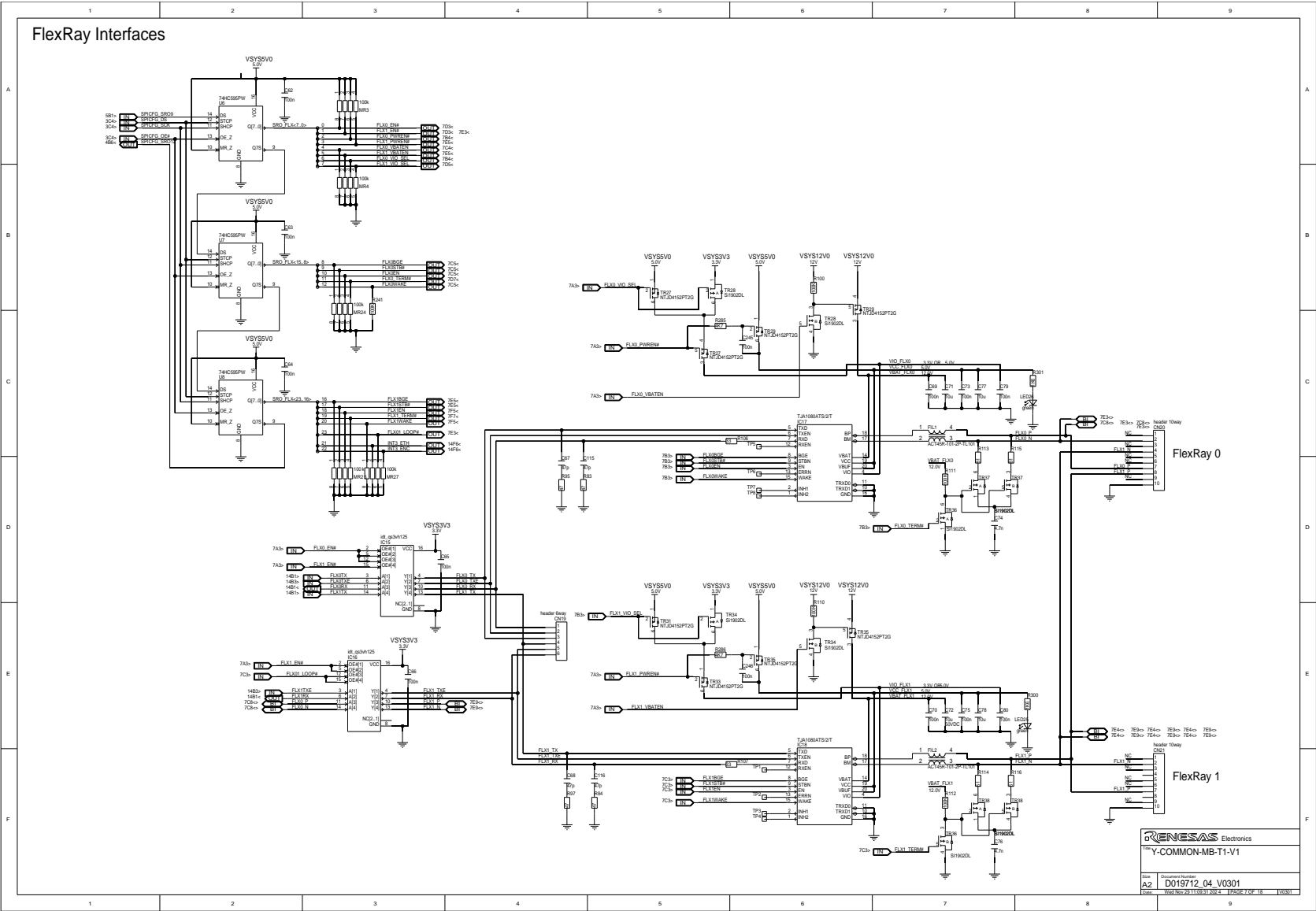

8.2.8 Page 8: Ethernet / SD Card / SFMA / I2S

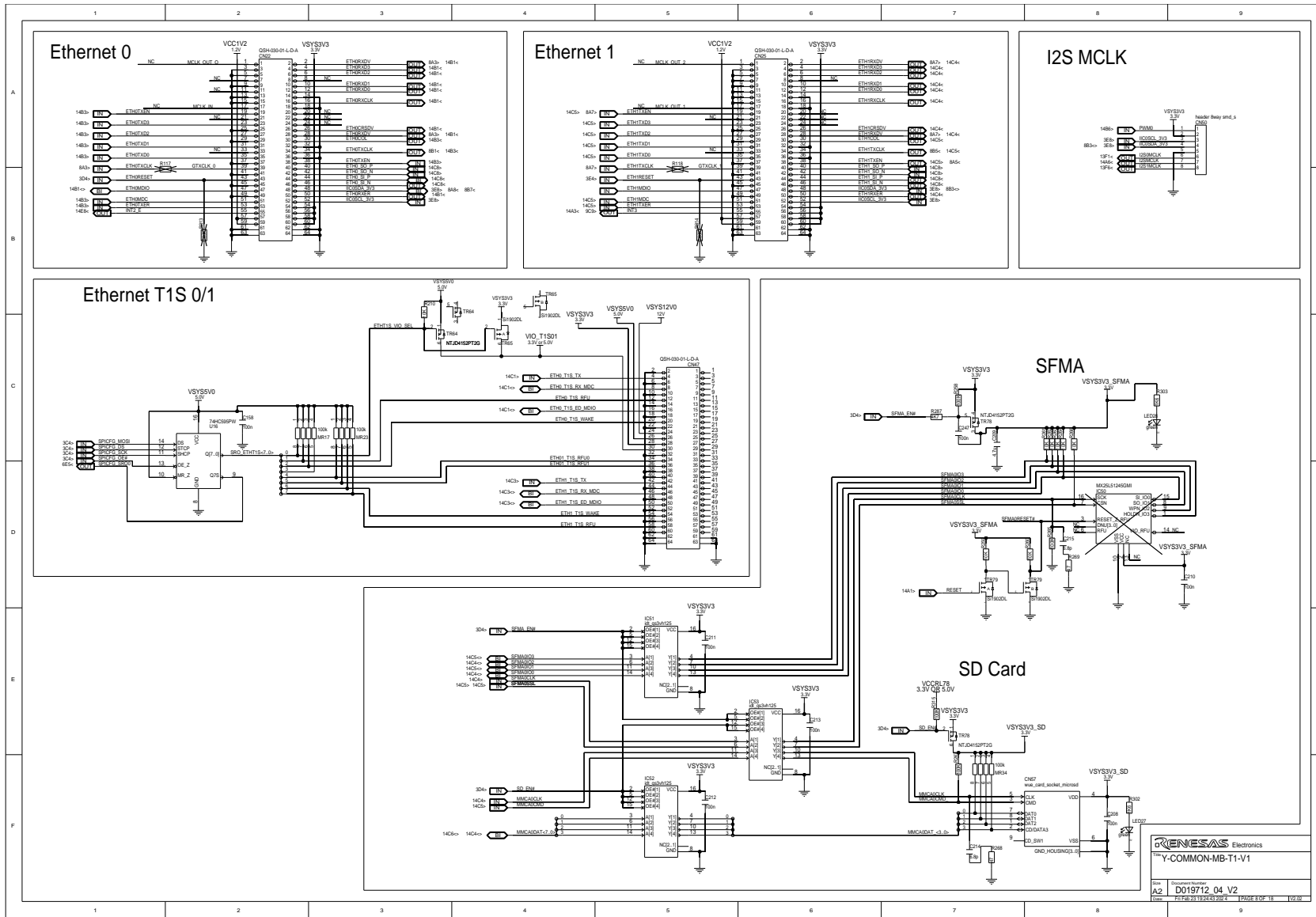

8.2.9 Page 9: Encoder / LED CSI Driver

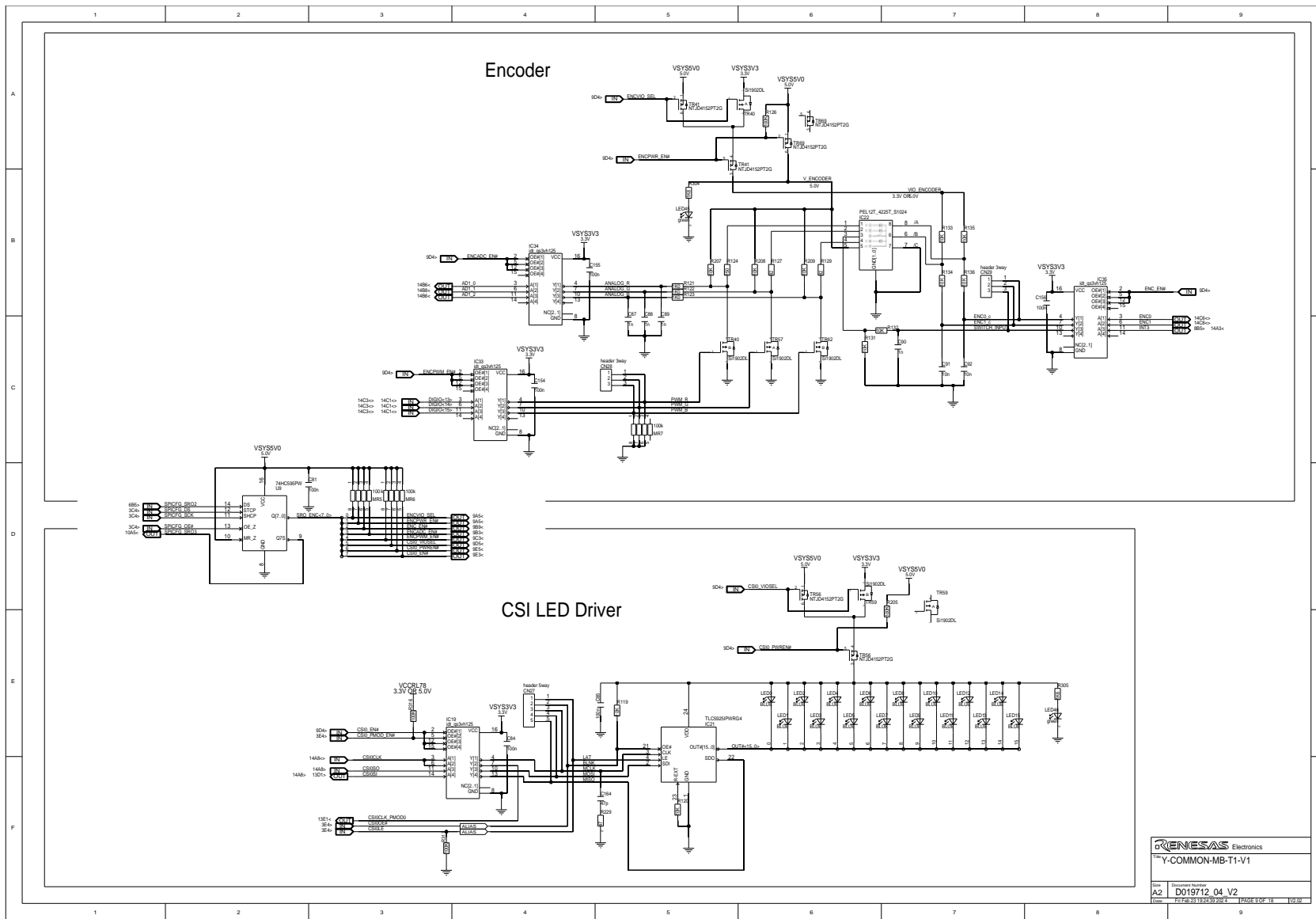

8.2.10 Page 10: Display / Interrupt / A/D Measurement

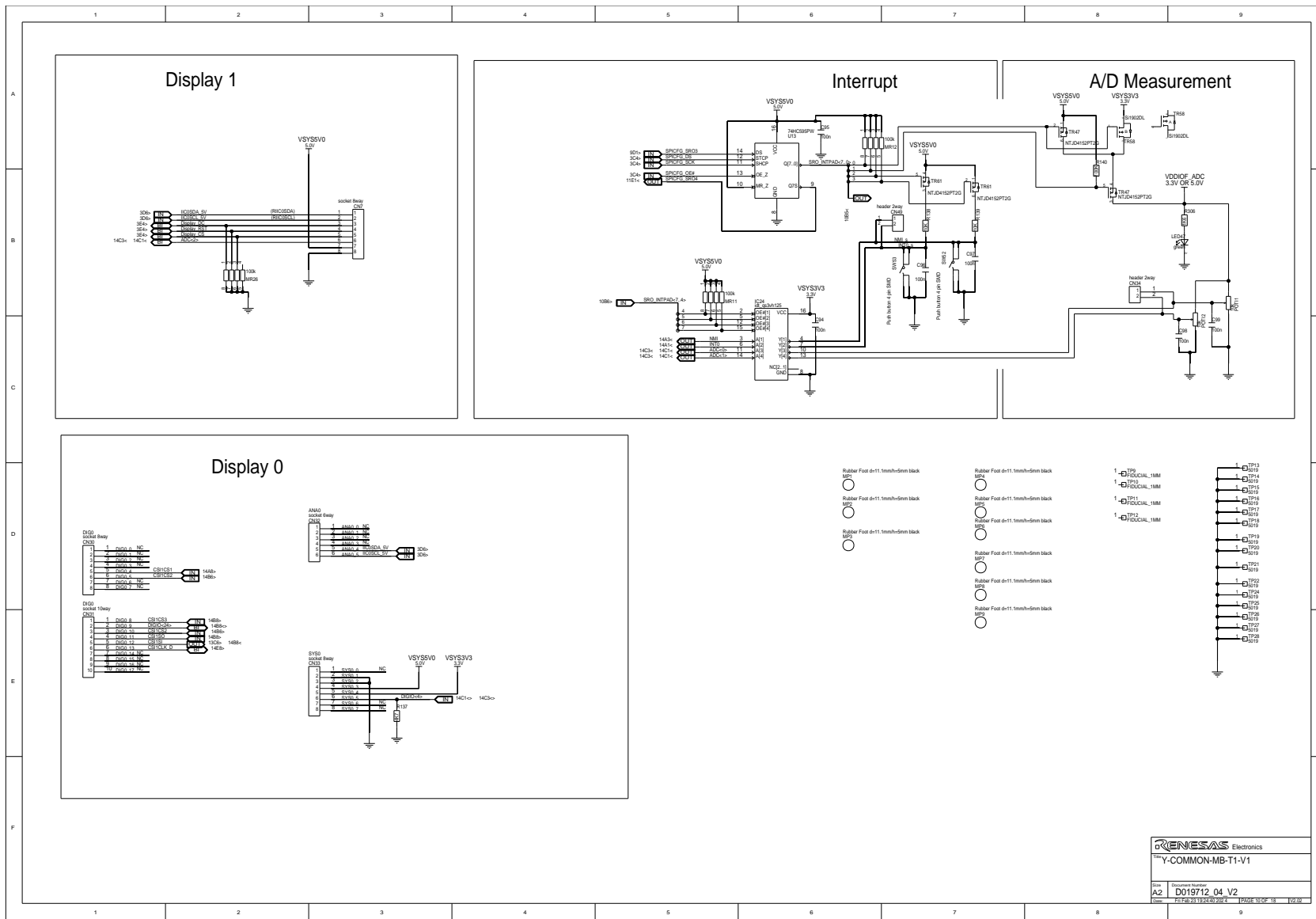

8.2.11 Page 11: Resolver

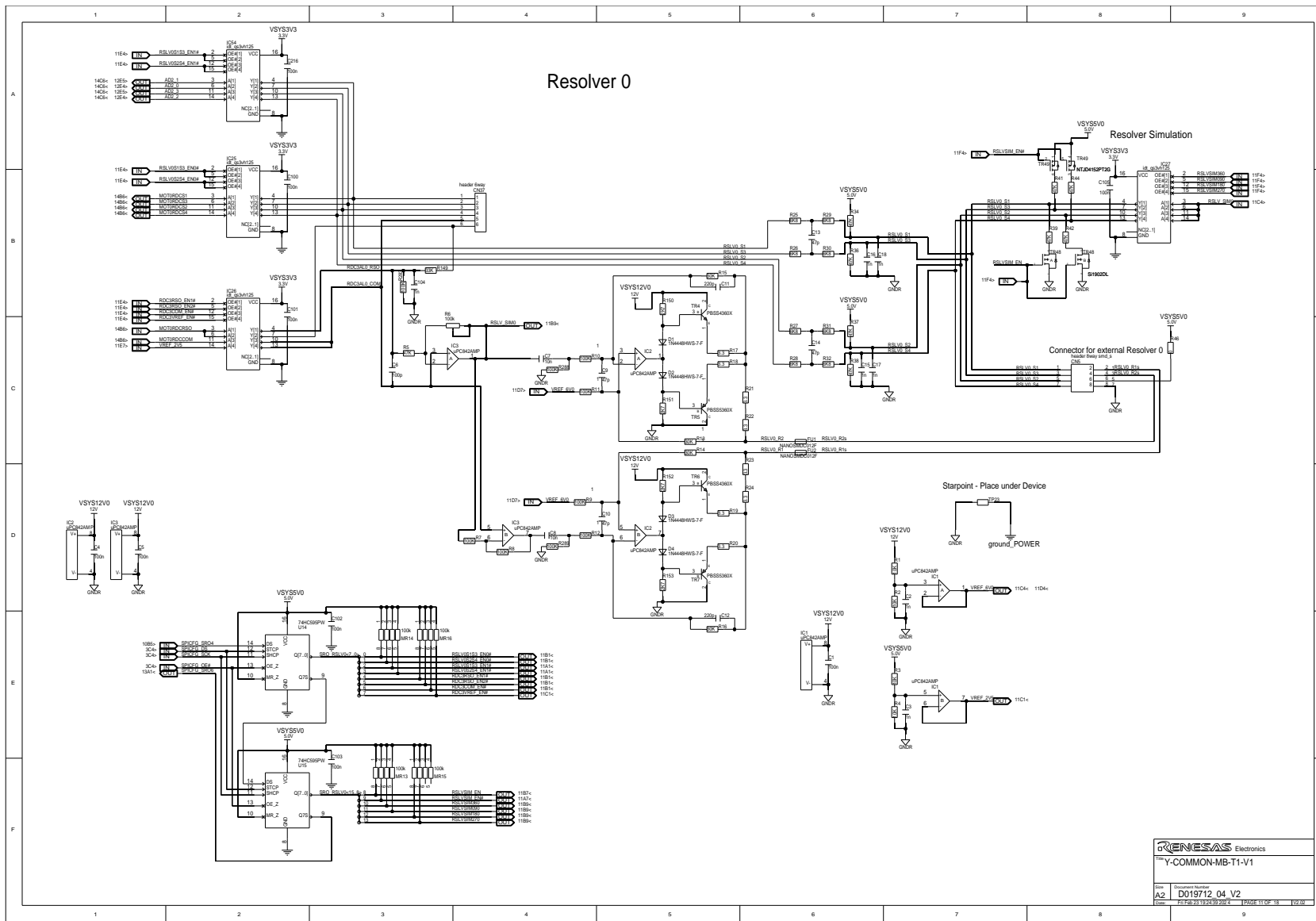

Y-COMMON-MB-T1-V1	
Rev.	Document Number
A.2	D019712_04_V2
Date	Fri Feb 21 10:28:30 2025
Page	11 of 18

8.2.12 Page 12: Motor

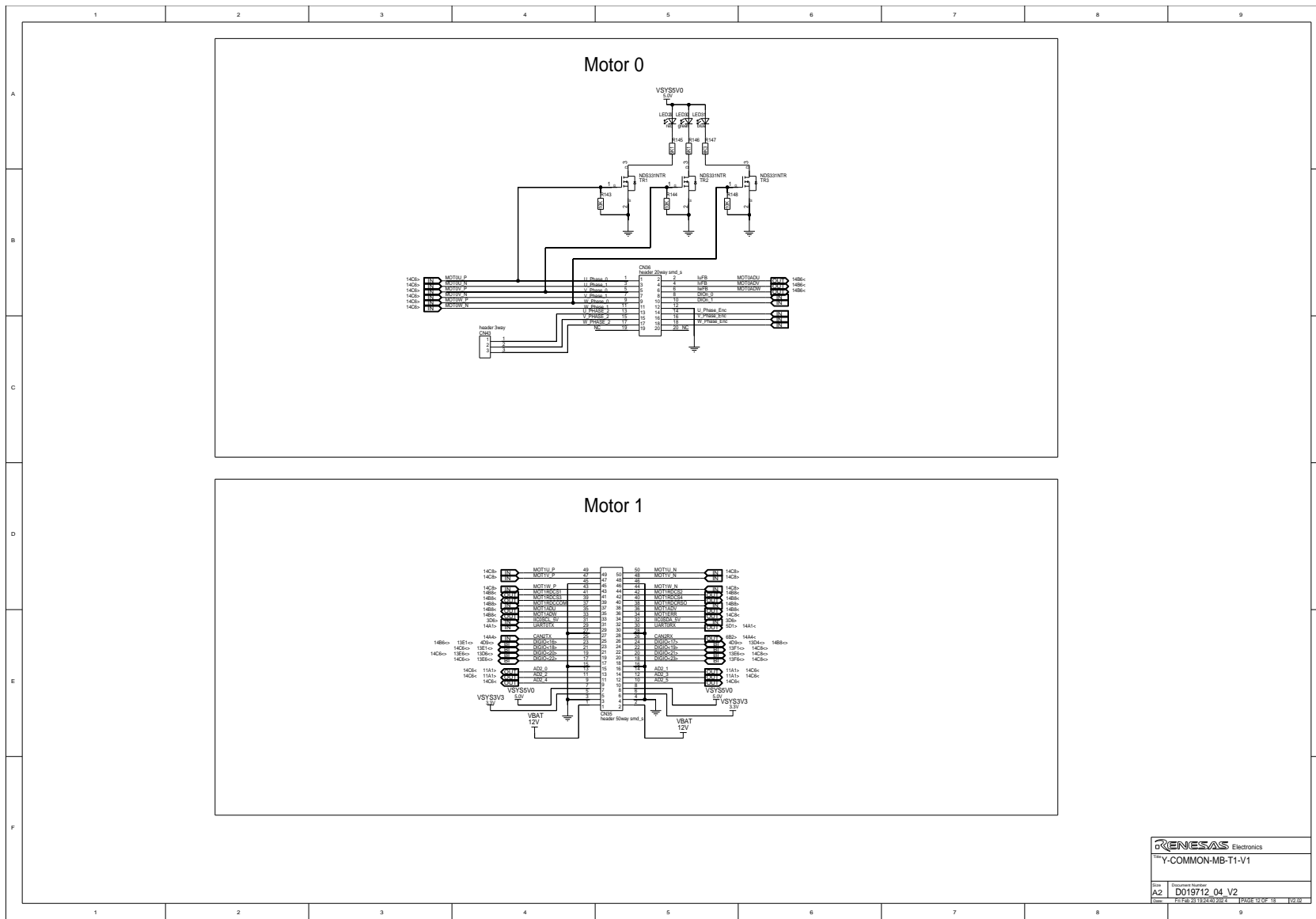

Y-COMMON-MB-T1-V1	
Date:	Document Number:
A2	D019712_04_V2
Date:	File Path: 21.10.22.01.2019
1/20	1/20

8.2.14 Page 14: Piggyback Connectors / Multiplexer

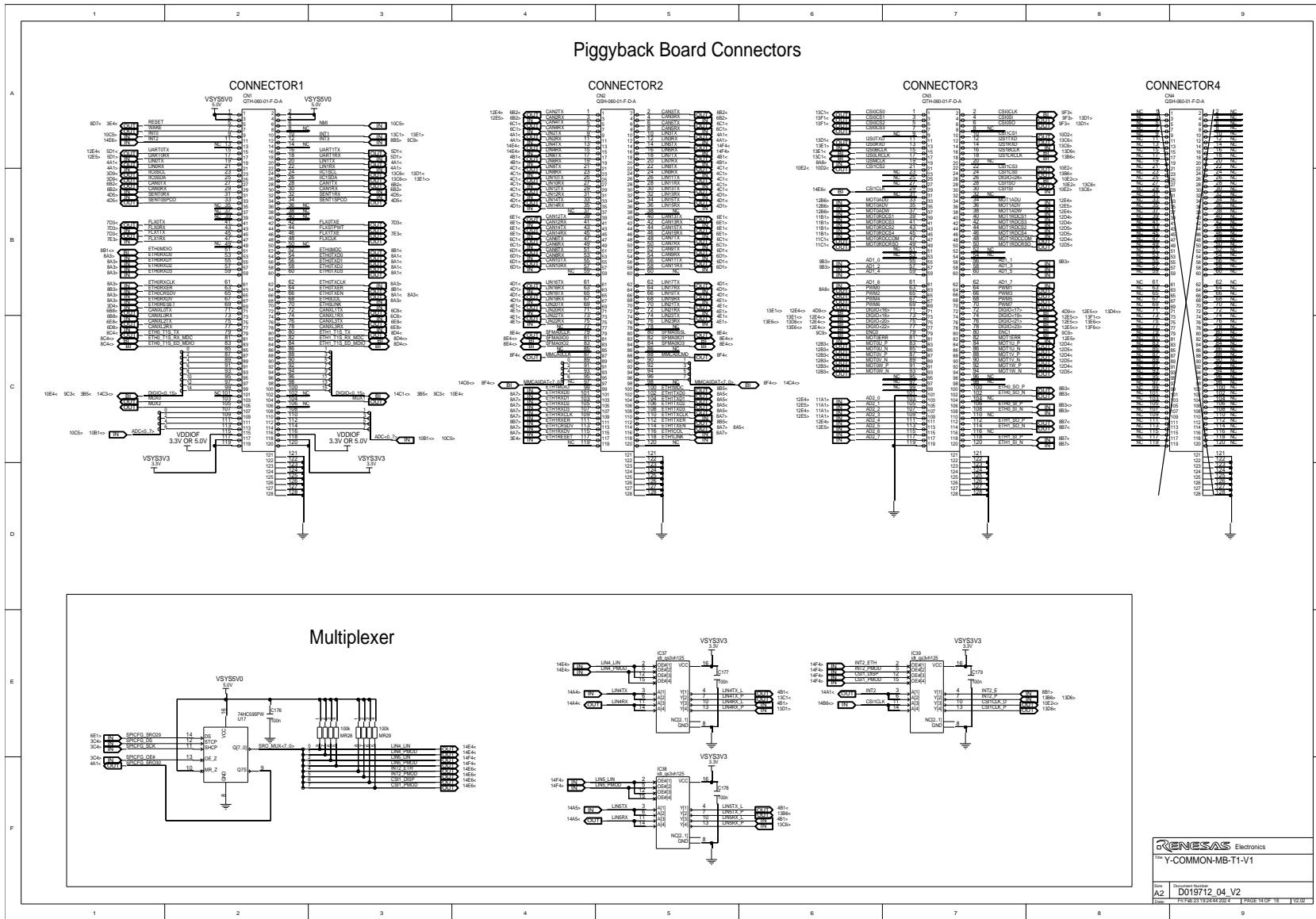

8.2.15 Page 15: LIN Transceiver X4

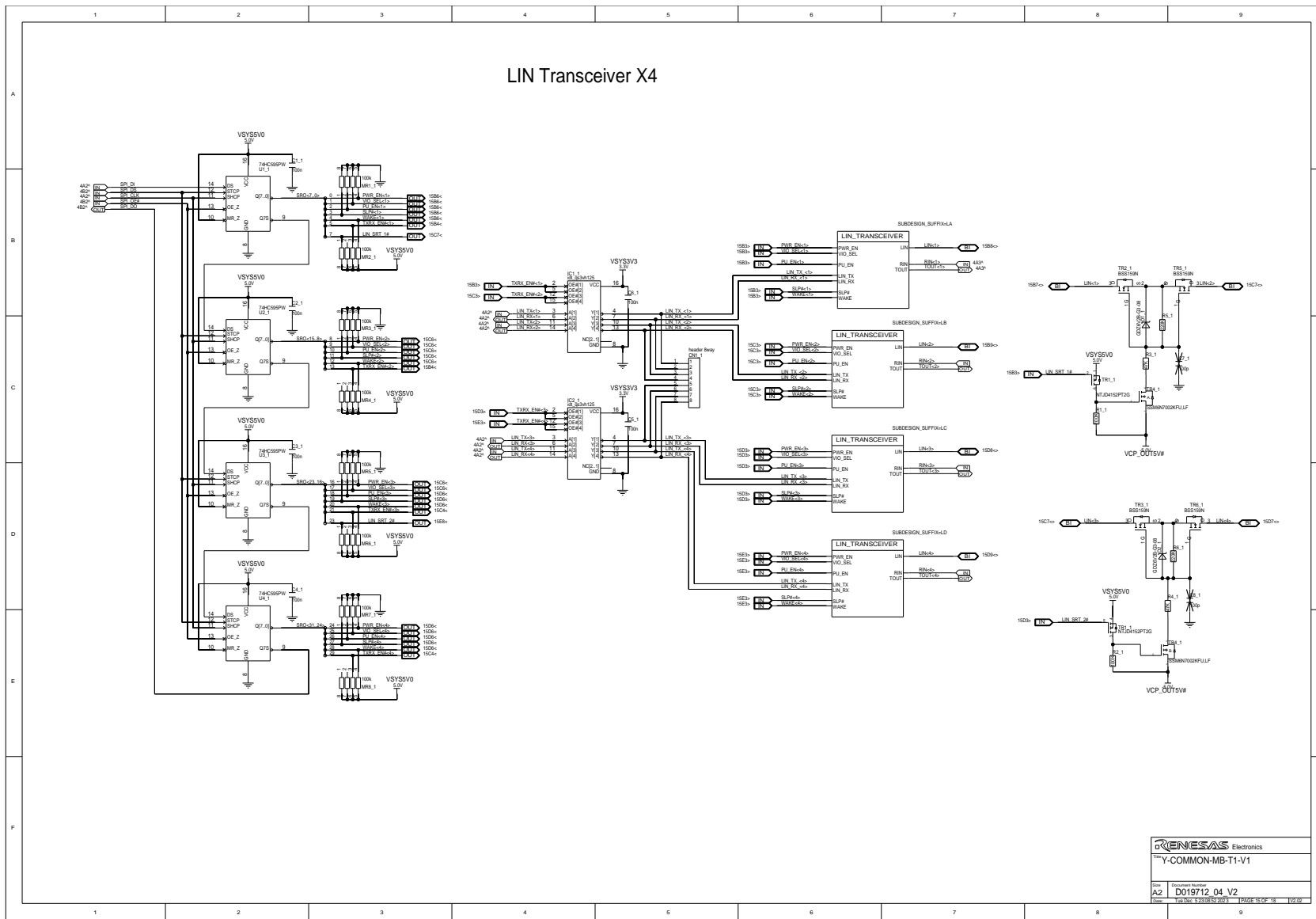

Y-COMMON-MB-T1-V1	
Date: A2	Document Number: D019712 04 V2
Date: 2016/02/26	Page: 15 of 18

8.2.16 Page 16: LIN Transceiver

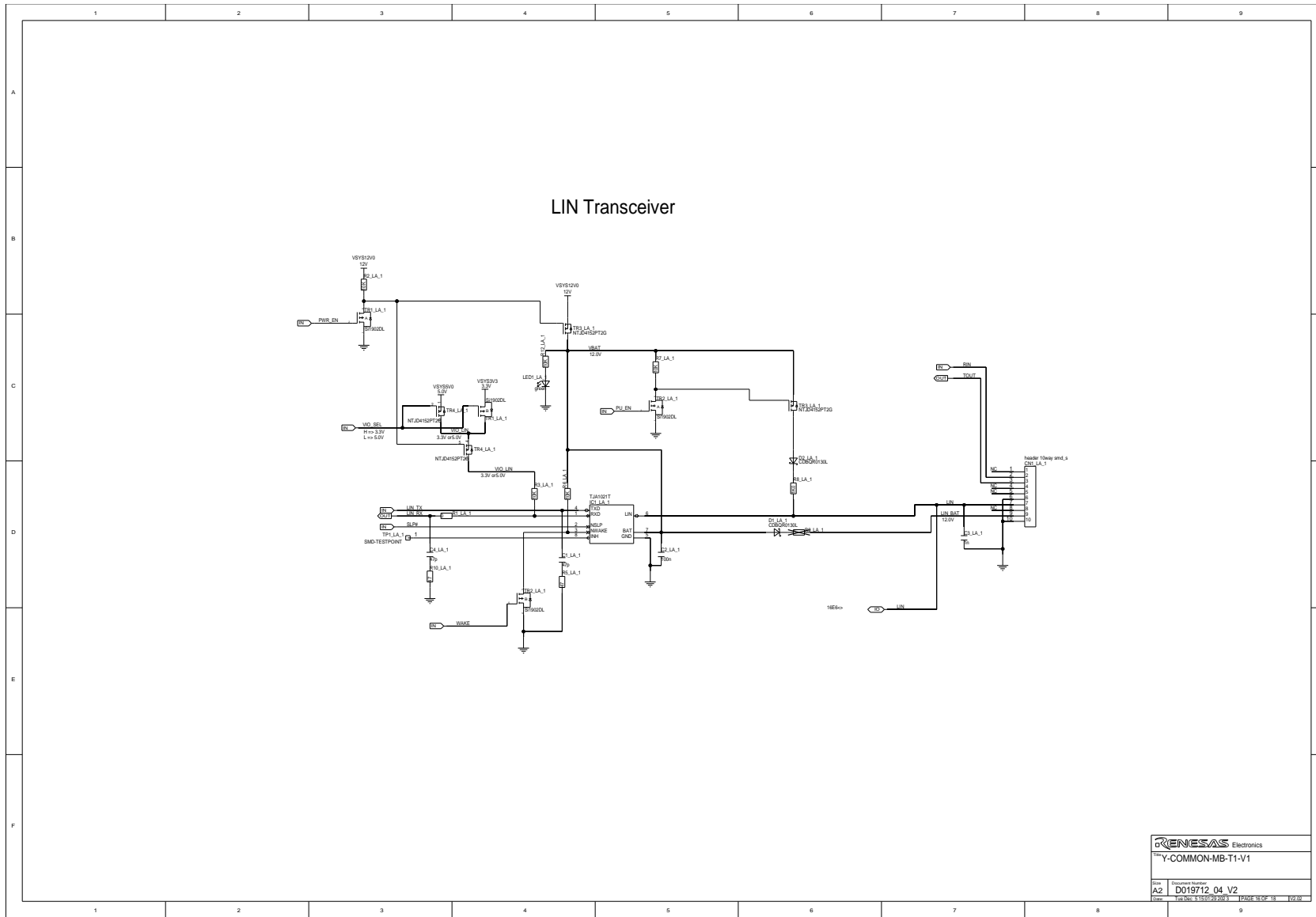

RENESAS Electronics	
Y-COMMON-MB-T1-V1	
Doc. No.	Document Number
A2	D019712_04_V2
Date	1st Ed. 3/10/2022 1/25th of 11 10/24

8.2.17 Page 17: CAN Transceiver X4

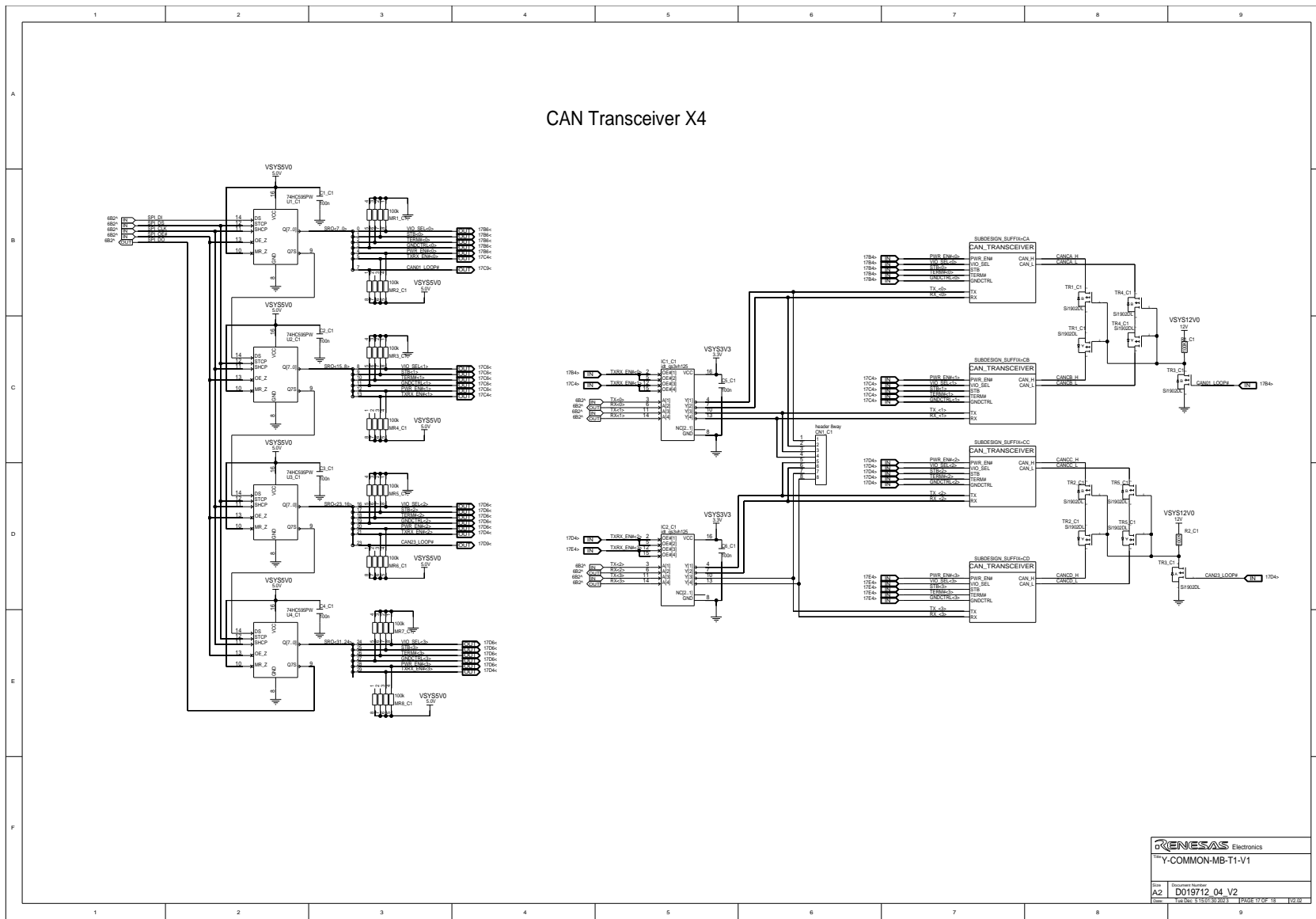

Y-COMMON-MB-T1-V1	
Rev.	Document Number
A2	D019712_04_V2
Date	(Use date: \$1308302021) 1/20/21 17 OF 18 1/2/21

8.2.18 Page 18: CAN Transceiver

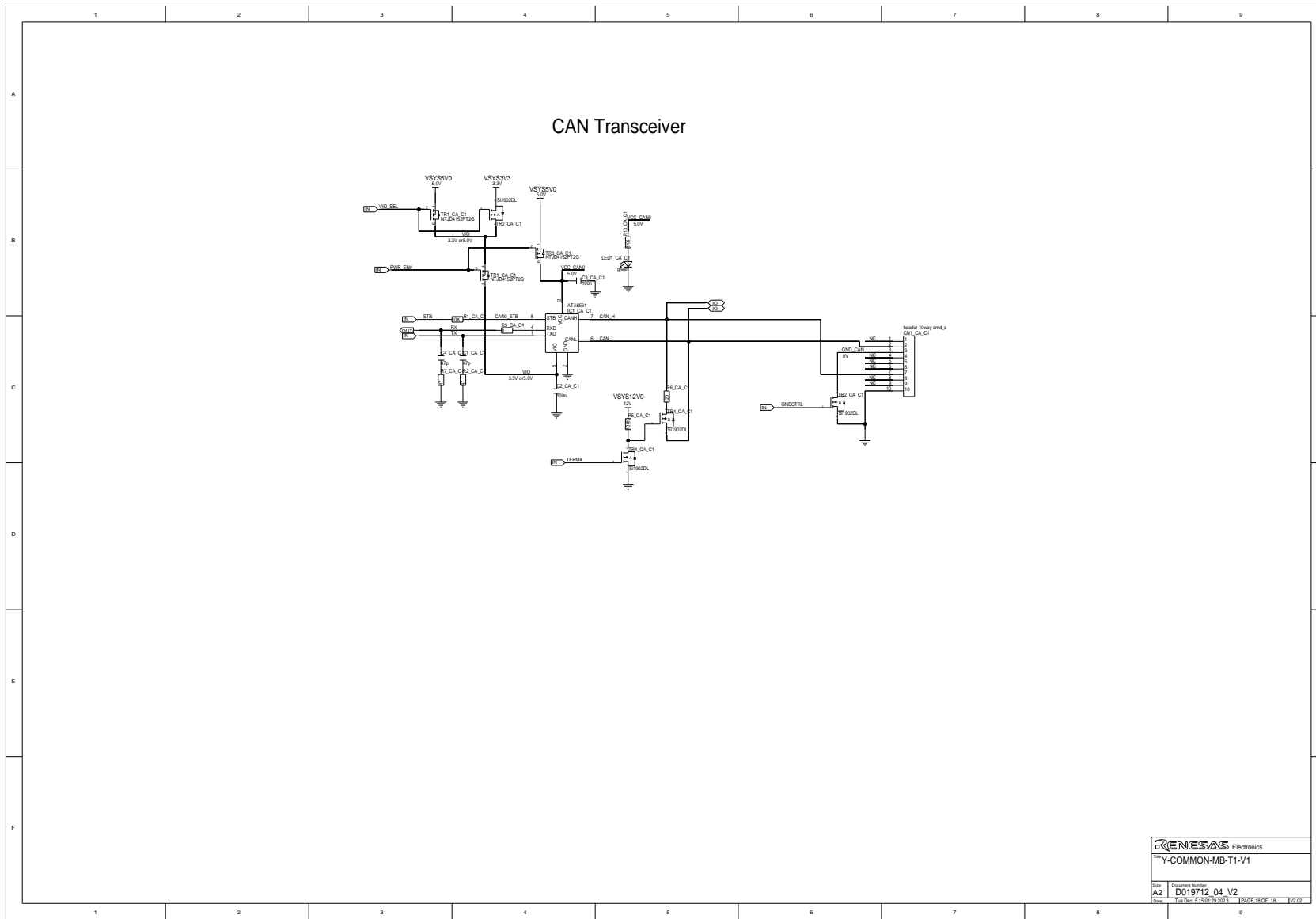

8.3 Board Version D019712_06_V03

8.3.1 Page 1: Table of Contents

	1	2	3	4	5	6	7	8	9																																						
A	<h1>Y-COMMON-MB-T1-V1</h1>						<table border="1" style="width: 100%; border-collapse: collapse;"> <thead> <tr> <th>REV</th> <th>COMMENT</th> <th>DATE</th> <th>DRAWN BY</th> </tr> </thead> <tbody> <tr> <td>V0100</td> <td>Initial release</td> <td>18.07.2023</td> <td>FR</td> </tr> <tr> <td>V0104</td> <td>D019712_04_S03_V0104_y_common_mb_t1_v1_RevisionHistory.txt</td> <td>14.11.2023</td> <td>FR</td> </tr> <tr> <td>V0105</td> <td>D019712_04_S03_V0105_y_common_mb_t1_v1_RevisionHistory.txt</td> <td>05.12.2023</td> <td>FR</td> </tr> <tr> <td>V0200</td> <td>D019712_04_S03_V0200_y_common_mb_t1_v1_RevisionHistory.txt</td> <td>08.12.2023</td> <td>FR/LS</td> </tr> <tr> <td>V0202</td> <td>D019712_04_S03_V0202_y_common_mb_t1_v1_RevisionHistory.txt</td> <td>22.02.2024</td> <td>FR/LS/ME</td> </tr> <tr> <td>V0301</td> <td>D019712_04_S03_V0301_y_common_mb_t1_v1_RevisionHistory.txt</td> <td>21.11.2024</td> <td>ME</td> </tr> <tr> <td>V0302</td> <td>D019712_04_S03_V0302_y_common_mb_t1_v1_RevisionHistory.txt</td> <td>26.02.2025</td> <td>ME</td> </tr> </tbody> </table>			REV	COMMENT	DATE	DRAWN BY	V0100	Initial release	18.07.2023	FR	V0104	D019712_04_S03_V0104_y_common_mb_t1_v1_RevisionHistory.txt	14.11.2023	FR	V0105	D019712_04_S03_V0105_y_common_mb_t1_v1_RevisionHistory.txt	05.12.2023	FR	V0200	D019712_04_S03_V0200_y_common_mb_t1_v1_RevisionHistory.txt	08.12.2023	FR/LS	V0202	D019712_04_S03_V0202_y_common_mb_t1_v1_RevisionHistory.txt	22.02.2024	FR/LS/ME	V0301	D019712_04_S03_V0301_y_common_mb_t1_v1_RevisionHistory.txt	21.11.2024	ME	V0302	D019712_04_S03_V0302_y_common_mb_t1_v1_RevisionHistory.txt	26.02.2025	ME	A					
REV	COMMENT	DATE	DRAWN BY																																												
V0100	Initial release	18.07.2023	FR																																												
V0104	D019712_04_S03_V0104_y_common_mb_t1_v1_RevisionHistory.txt	14.11.2023	FR																																												
V0105	D019712_04_S03_V0105_y_common_mb_t1_v1_RevisionHistory.txt	05.12.2023	FR																																												
V0200	D019712_04_S03_V0200_y_common_mb_t1_v1_RevisionHistory.txt	08.12.2023	FR/LS																																												
V0202	D019712_04_S03_V0202_y_common_mb_t1_v1_RevisionHistory.txt	22.02.2024	FR/LS/ME																																												
V0301	D019712_04_S03_V0301_y_common_mb_t1_v1_RevisionHistory.txt	21.11.2024	ME																																												
V0302	D019712_04_S03_V0302_y_common_mb_t1_v1_RevisionHistory.txt	26.02.2025	ME																																												
B	<table border="1" style="width: 100%; border-collapse: collapse;"> <thead> <tr> <th colspan="2">Table of Contents</th> </tr> <tr> <th>Page No.</th> <th>Page Name</th> </tr> </thead> <tbody> <tr><td>1</td><td>Table of Contents</td></tr> <tr><td>2</td><td>Power Supply</td></tr> <tr><td>3</td><td>Voltage-/Signal LED'S / IIC0 / Board Configurator</td></tr> <tr><td>4</td><td>LIN / SENT Interfaces</td></tr> <tr><td>5</td><td>UART Interfaces</td></tr> <tr><td>6</td><td>CAN (XL) Interfaces</td></tr> <tr><td>7</td><td>FlexRay Interfaces</td></tr> <tr><td>8</td><td>Ethernet / SD-Card / SFMA / I2S Interface</td></tr> <tr><td>9</td><td>Encoder / LED CSI Driver</td></tr> <tr><td>10</td><td>Display / Interrupt / AD Measurement</td></tr> <tr><td>11</td><td>Resolver</td></tr> <tr><td>12</td><td>Motor</td></tr> <tr><td>13</td><td>PMOD Interfaces</td></tr> <tr><td>14</td><td>Piggyback Connectors / Multiplexer</td></tr> <tr><td>15</td><td>LIN Transceiver X4</td></tr> <tr><td>16</td><td>LIN Transceiver</td></tr> <tr><td>17</td><td>CAN Transceiver X4</td></tr> <tr><td>18</td><td>CAN Transceiver</td></tr> </tbody> </table>						Table of Contents		Page No.	Page Name	1	Table of Contents	2	Power Supply	3	Voltage-/Signal LED'S / IIC0 / Board Configurator	4	LIN / SENT Interfaces	5	UART Interfaces	6	CAN (XL) Interfaces	7	FlexRay Interfaces	8	Ethernet / SD-Card / SFMA / I2S Interface	9	Encoder / LED CSI Driver	10	Display / Interrupt / AD Measurement	11	Resolver	12	Motor	13	PMOD Interfaces	14	Piggyback Connectors / Multiplexer	15	LIN Transceiver X4	16	LIN Transceiver	17	CAN Transceiver X4	18	CAN Transceiver	B
Table of Contents																																															
Page No.	Page Name																																														
1	Table of Contents																																														
2	Power Supply																																														
3	Voltage-/Signal LED'S / IIC0 / Board Configurator																																														
4	LIN / SENT Interfaces																																														
5	UART Interfaces																																														
6	CAN (XL) Interfaces																																														
7	FlexRay Interfaces																																														
8	Ethernet / SD-Card / SFMA / I2S Interface																																														
9	Encoder / LED CSI Driver																																														
10	Display / Interrupt / AD Measurement																																														
11	Resolver																																														
12	Motor																																														
13	PMOD Interfaces																																														
14	Piggyback Connectors / Multiplexer																																														
15	LIN Transceiver X4																																														
16	LIN Transceiver																																														
17	CAN Transceiver X4																																														
18	CAN Transceiver																																														
C										C																																					
D										D																																					
E										E																																					
F							<table border="1" style="width: 100%; border-collapse: collapse;"> <tr> <td colspan="2" style="text-align: center;">RENESAS Electronics</td> </tr> <tr> <td colspan="2" style="text-align: center;">Title: Y-COMMON-MB-T1-V1</td> </tr> <tr> <td style="text-align: center;">Size: A3</td> <td style="text-align: center;">Document Number: D019712-04-V0302</td> </tr> <tr> <td colspan="2" style="text-align: center;">Date: Wed Feb 26 17:25:42 2025 PAGE 1 OF 18 V0302</td> </tr> </table>			RENESAS Electronics		Title: Y-COMMON-MB-T1-V1		Size: A3	Document Number: D019712-04-V0302	Date: Wed Feb 26 17:25:42 2025 PAGE 1 OF 18 V0302		F																													
RENESAS Electronics																																															
Title: Y-COMMON-MB-T1-V1																																															
Size: A3	Document Number: D019712-04-V0302																																														
Date: Wed Feb 26 17:25:42 2025 PAGE 1 OF 18 V0302																																															
	1	2	3	4	5	6	7	8	9																																						

8.3.2 Page 2: Power Supply

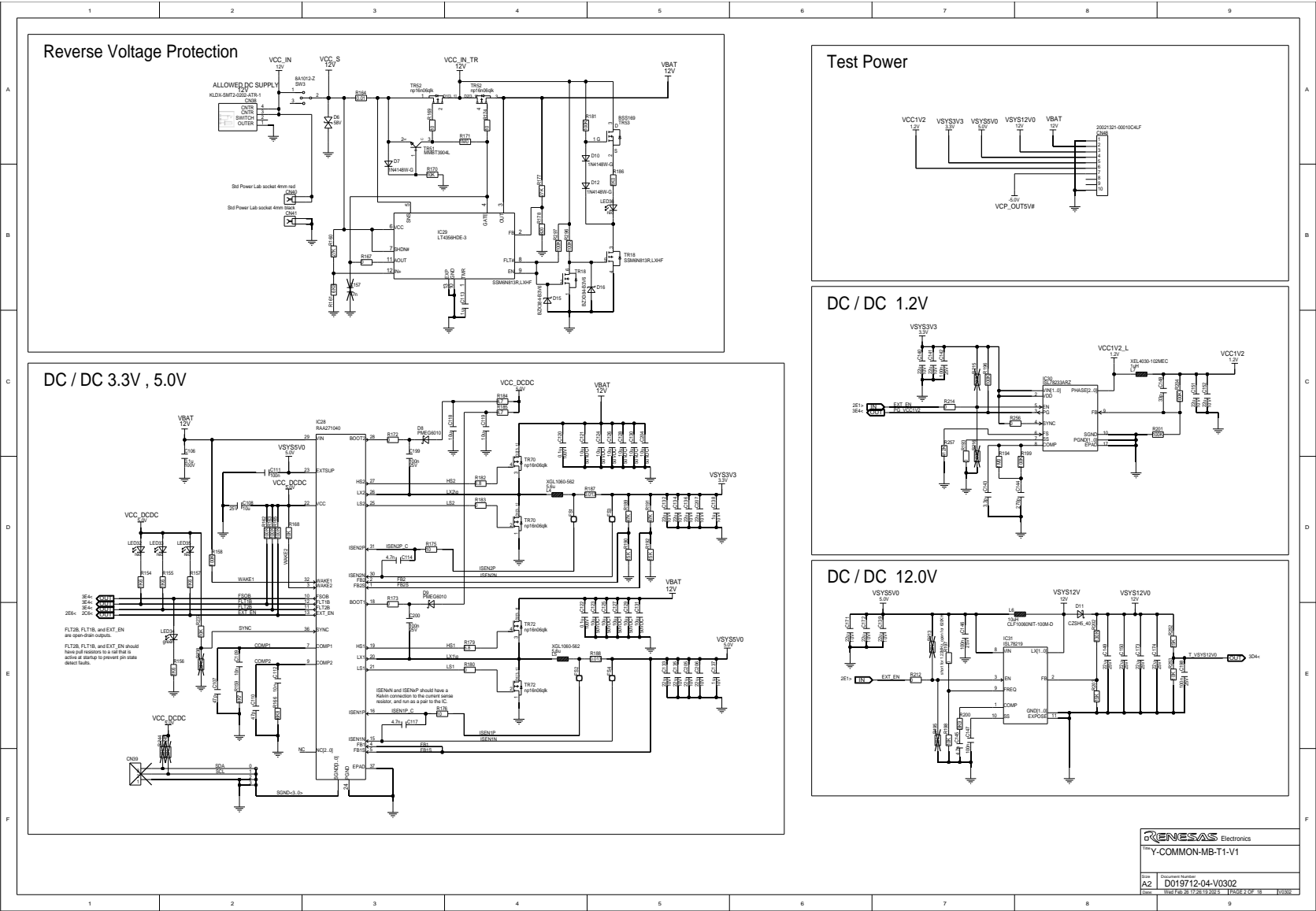

8.3.3 Page 3: Voltage-/Signal LEDs / IIC0 / Board Configurator

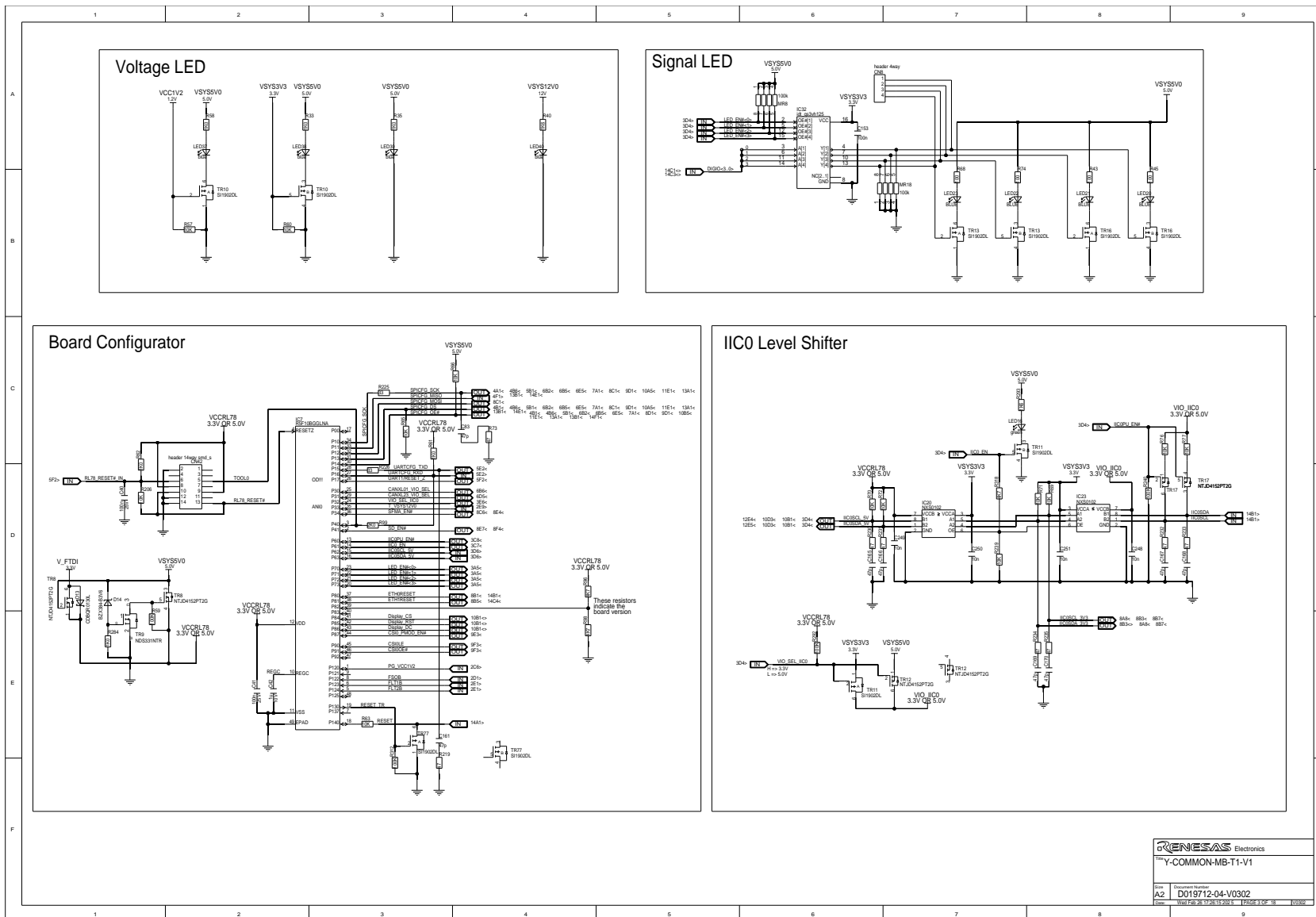

8.3.4 Page 4: LIN / SENT Interfaces

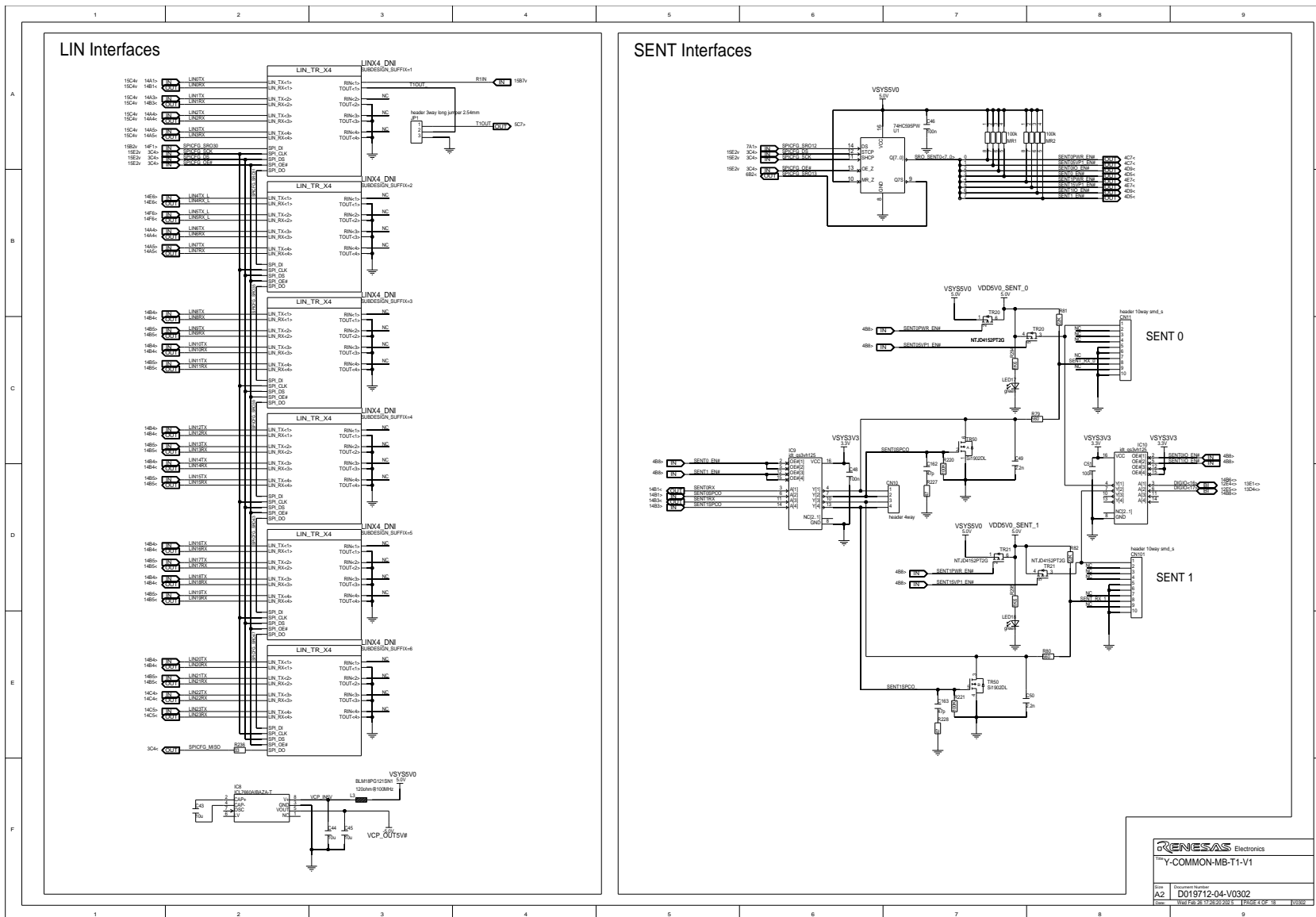

8.3.5 Page 5: UART Interfaces

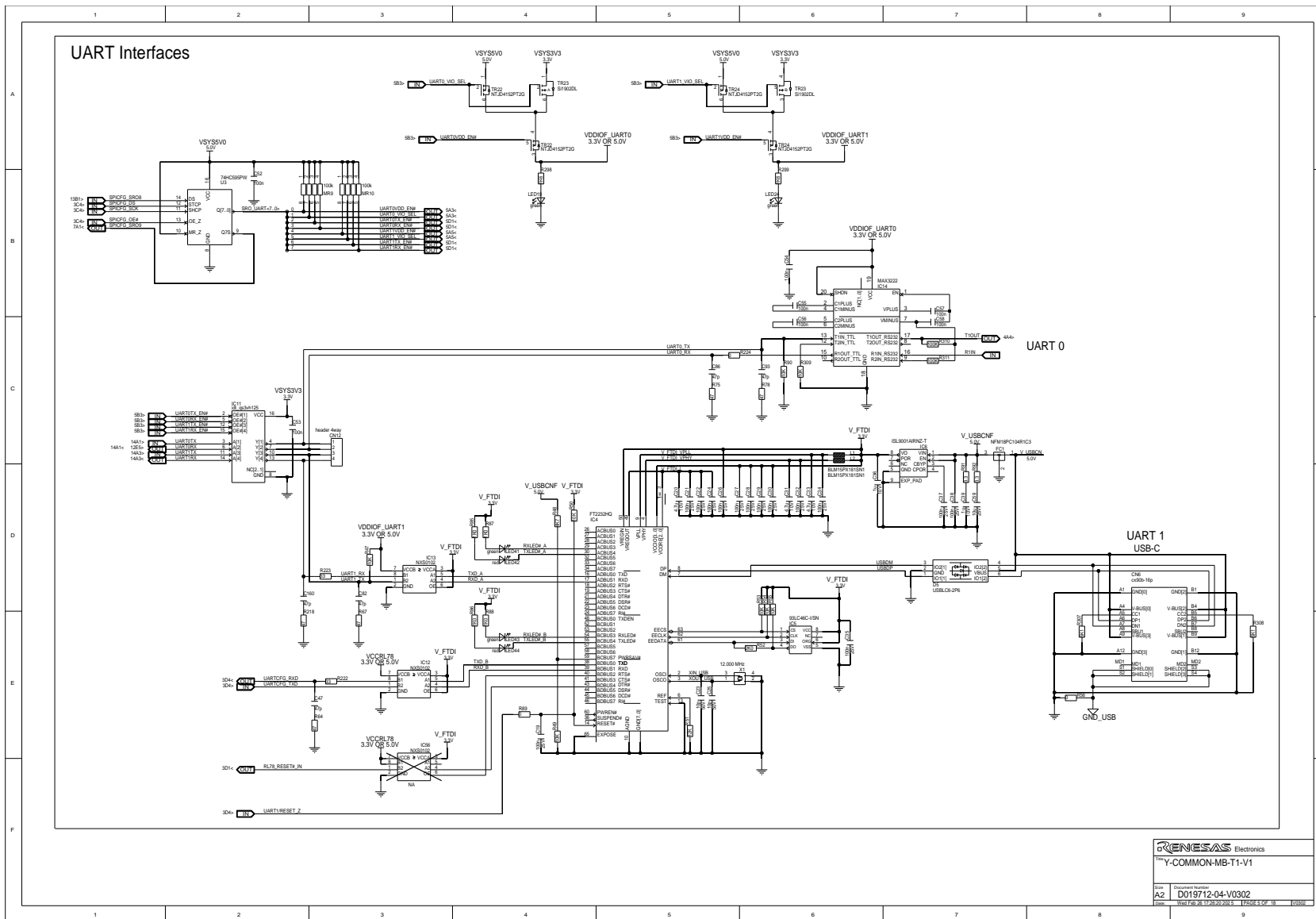

8.3.6 Page 6: CAN (XL) Interfaces

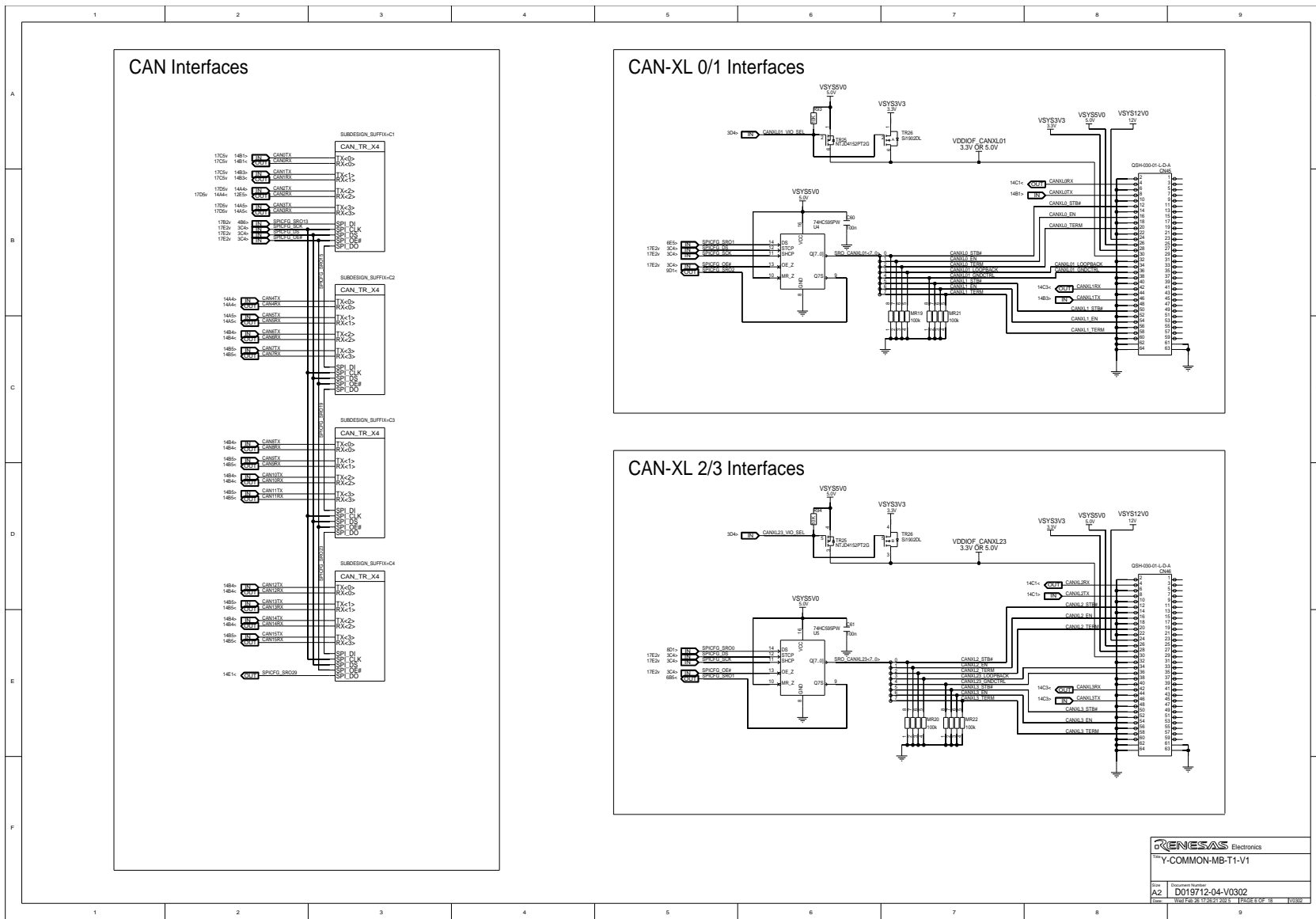

RENESAS Electronics
 Y-COMMON-MB-T1-V1
 Date: D019712-04-V0302
 Issue: 1/1

8.3.7 Page 7: FlexRay Interfaces

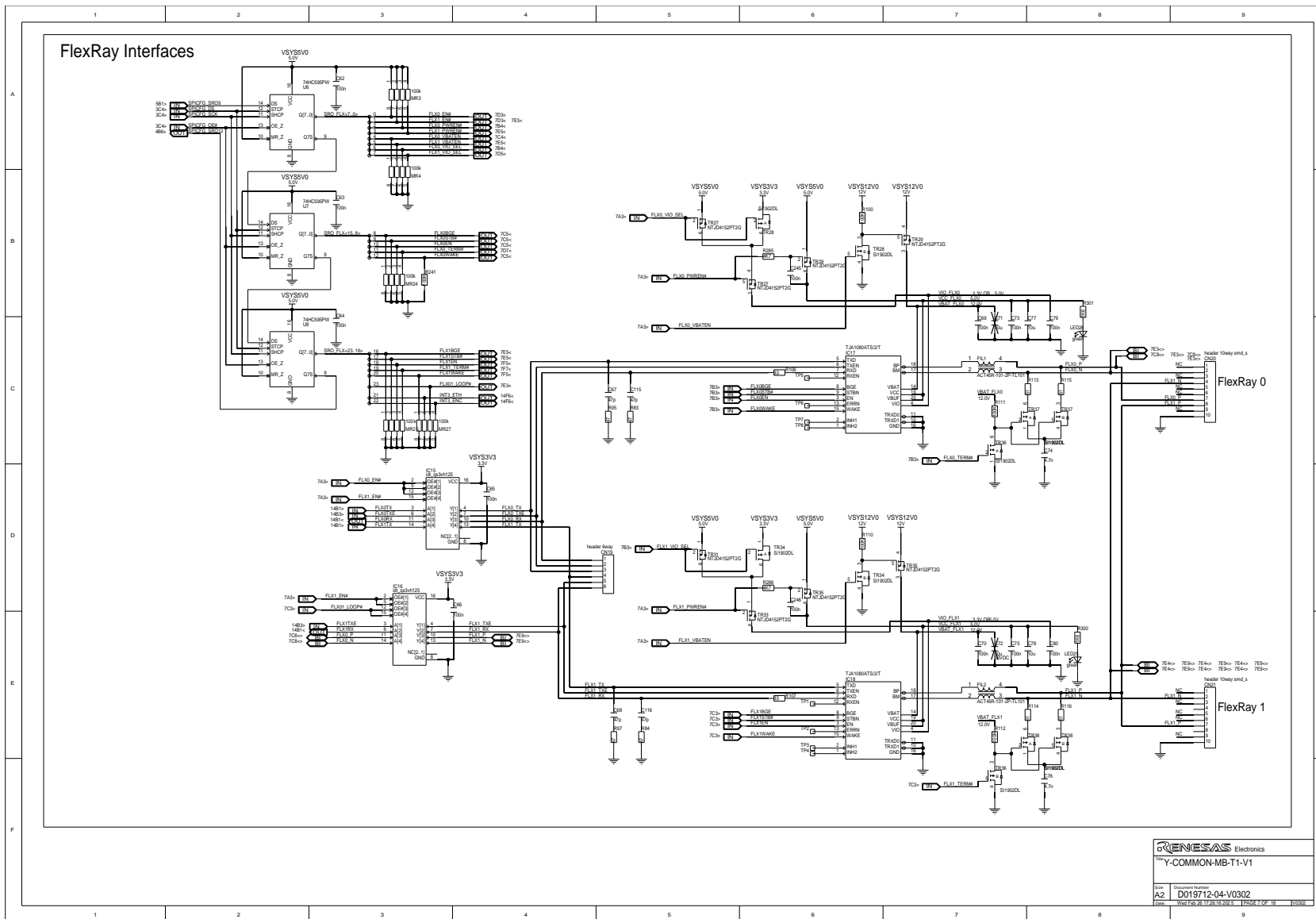

8.3.9 Page 9: Encoder / LED CSI Driver

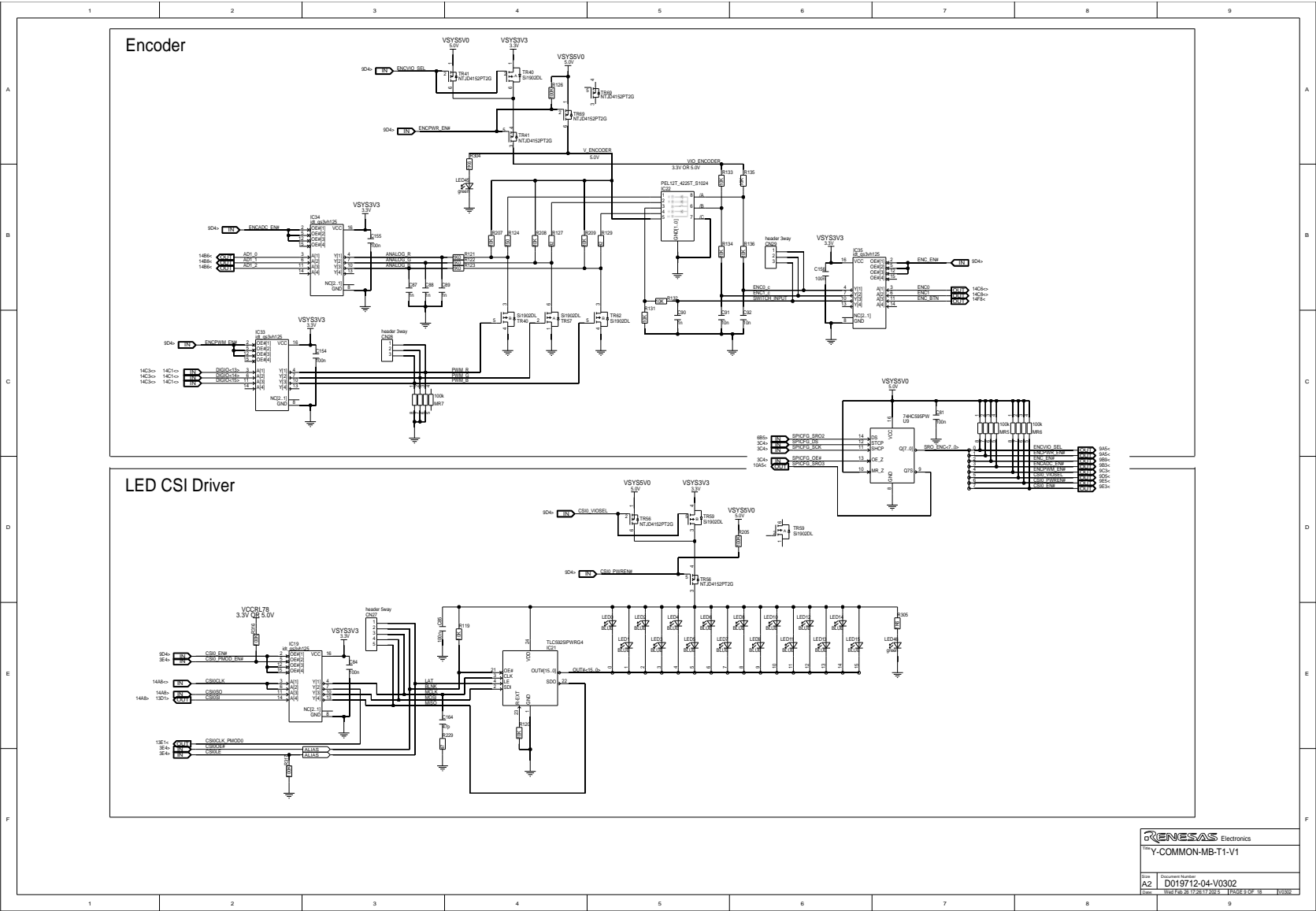

RENESAS Electronics

 Y-COMMON-MB-T1-V1

 Date: D019712-04-V0302

 A2

 Date: 2024/12/23

8.3.10 Page 10: Display / Interrupt / A/D Measurement

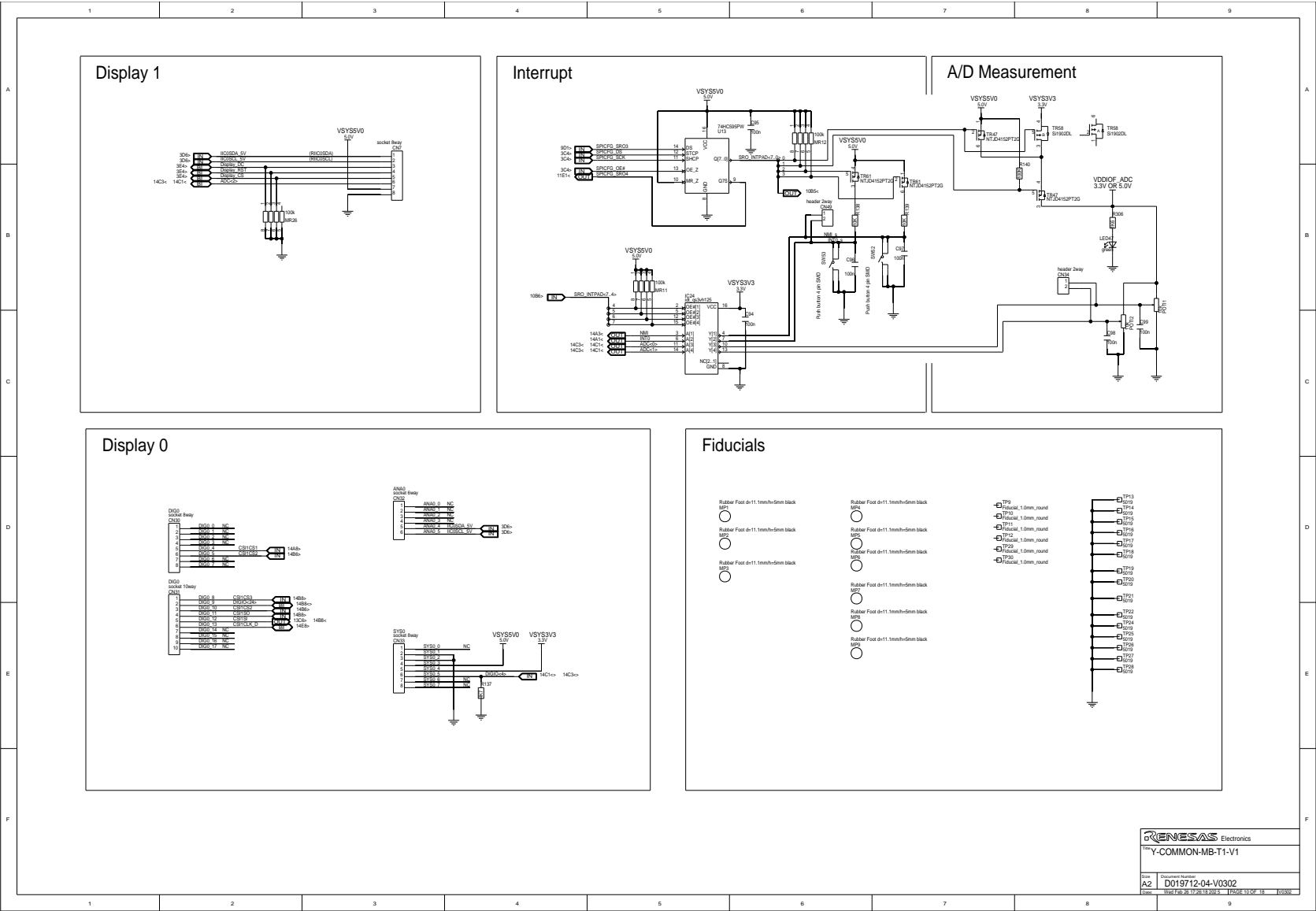

RENESAS Electronics	
Y-COMMON-MB-T1-V1	
Date	Document Number
A2	D019712-04-V0302
Date	Issue No.
2024.06.18	1/0000

8.3.11 Page 11: Resolver

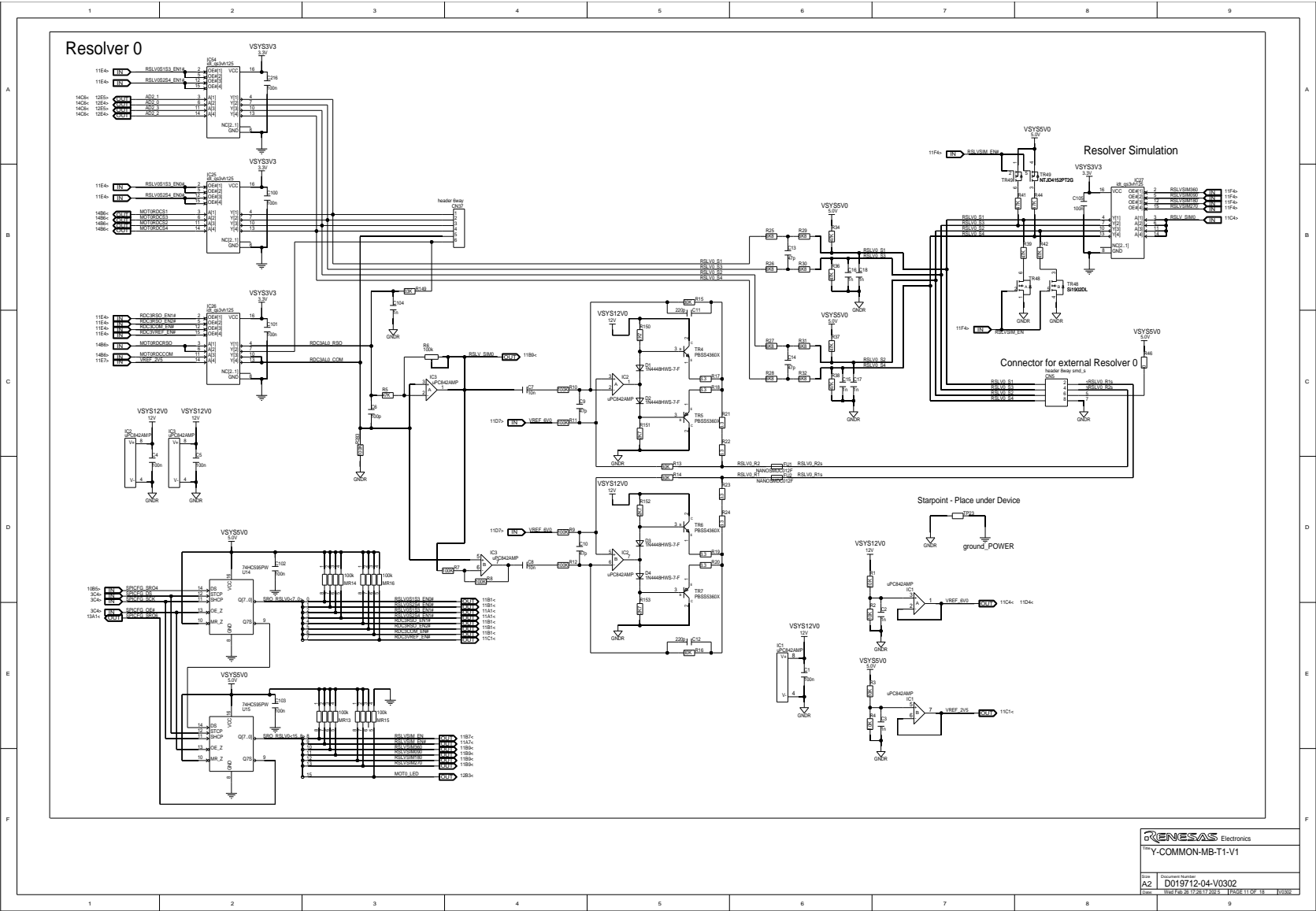

RENESAS Electronics
 Y-COMMON-MB-T1-V1
 Date: Document Number
 A2: D019712-04-V0302
 Date: 1997 Feb 28 / 2017 Sep 15 / 2024 11 Oct 18 / 2024

8.3.12 Page 12: Motor

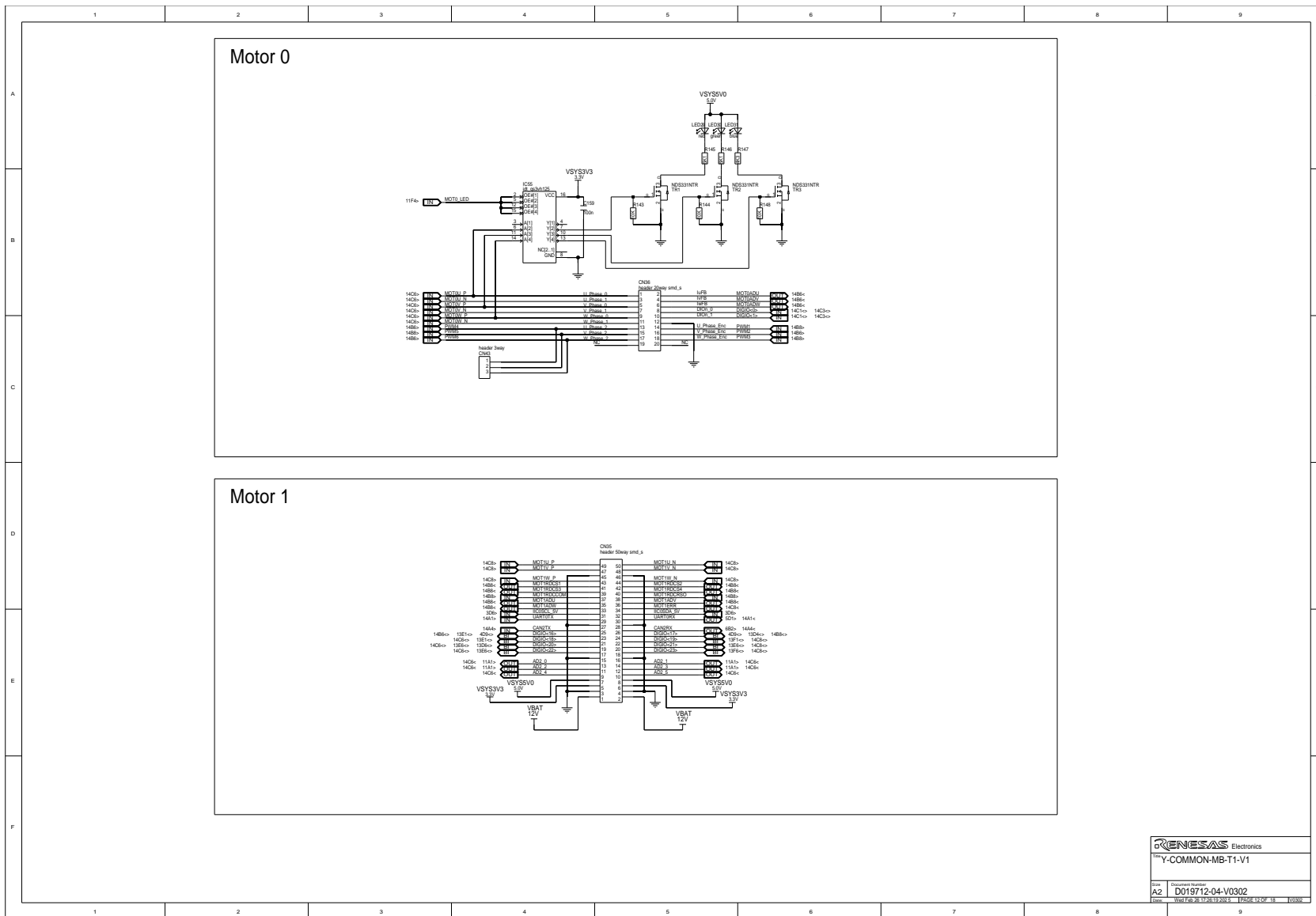

Y-COMMON-MB-T1-V1	
Date: A2	Document Number: D019712-04-V0302
File Path: \\fs1\prod\proj\p2013\1206\1206_01\ref_01\0302	

8.3.13 Page 13: Pmod™ Interfaces

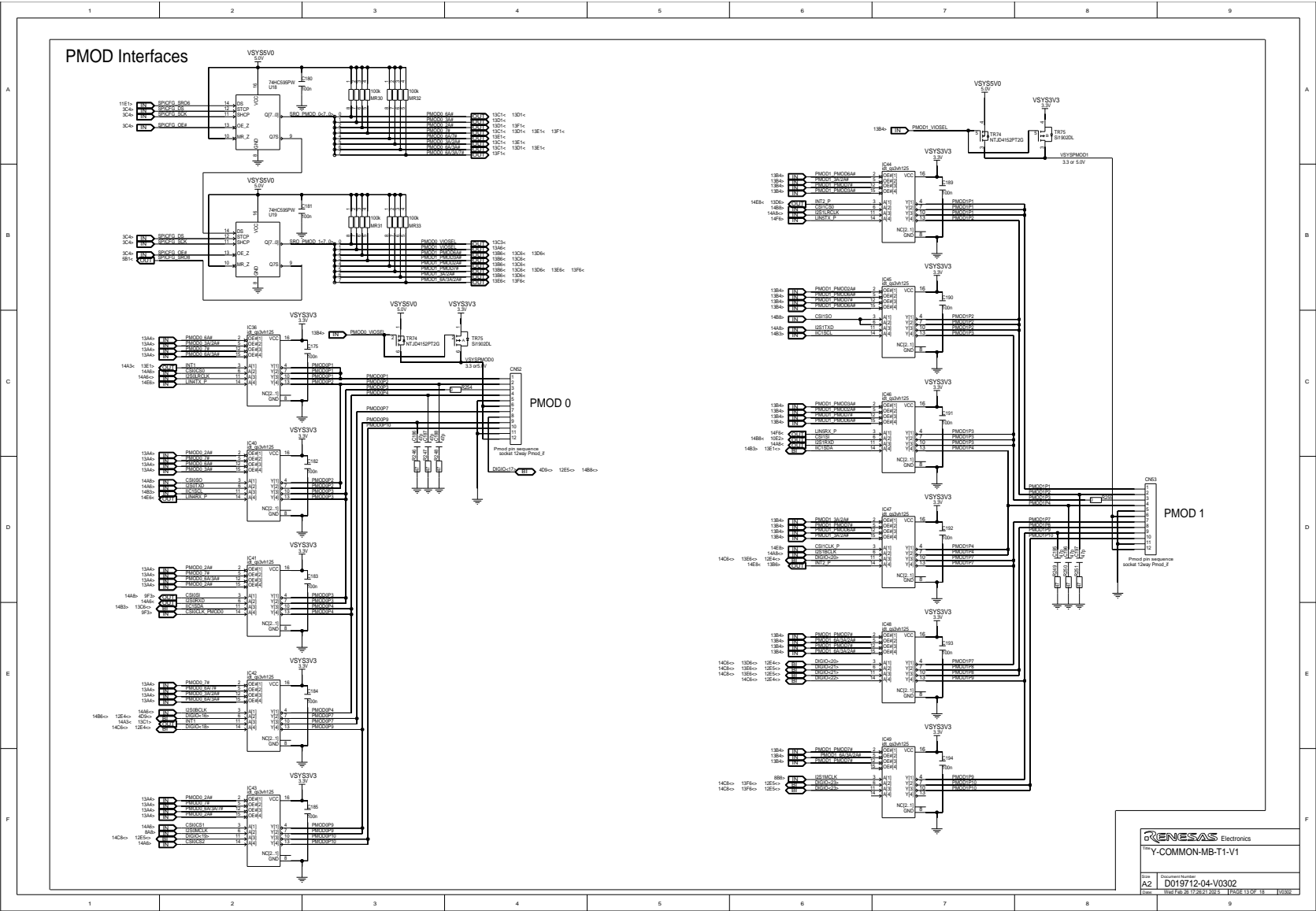

8.3.15 Page 15: LIN Transceiver X4

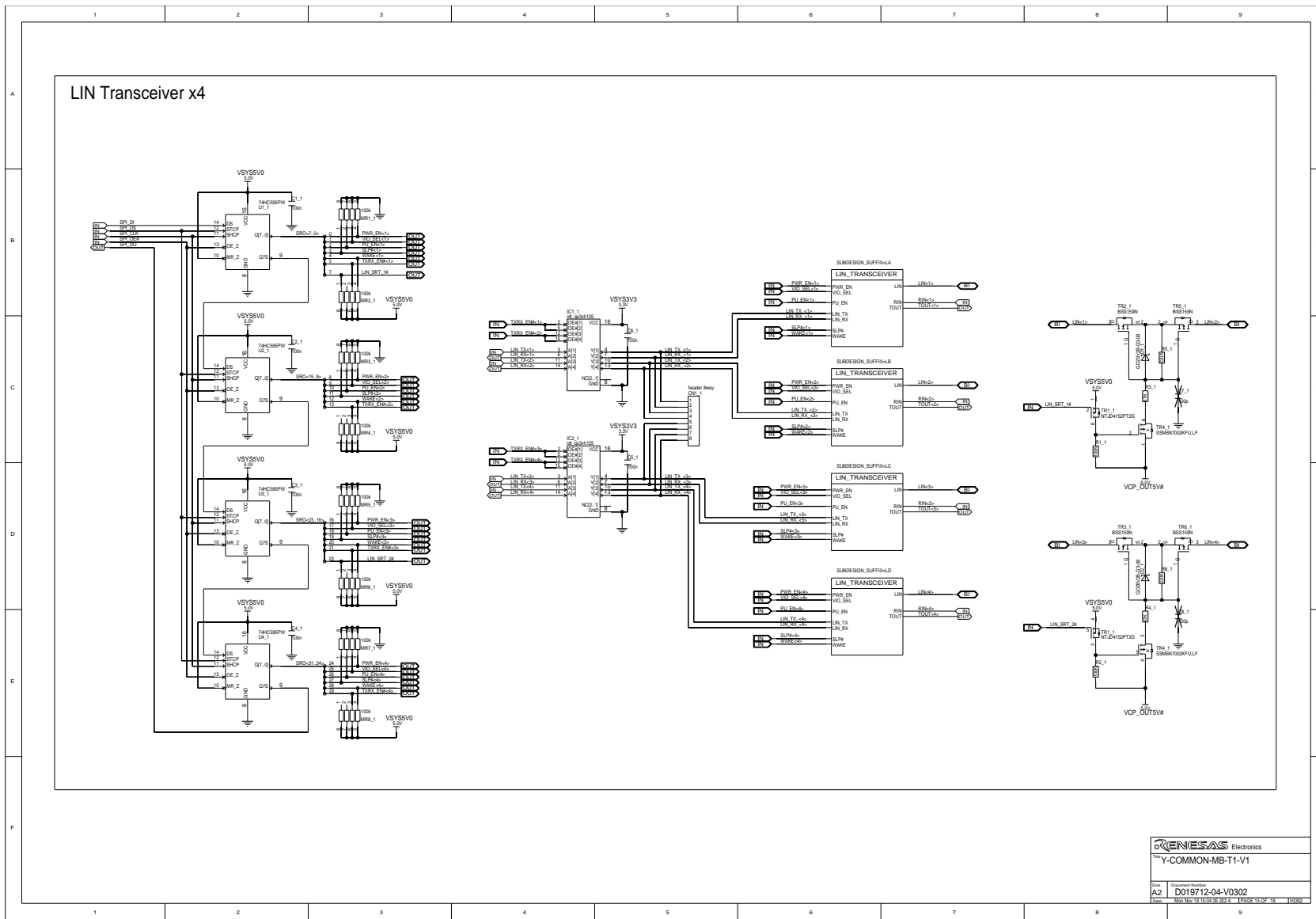

Y-COMMON-MB-T1-V1	
Date: A2	Document Number: D019712-04-V0302
File Path: Main Board for RH850 and R-Car U5x > 8. Schematics > 8.3.15 Page 15: LIN Transceiver X4	

8.3.17 Page 17: CAN Transceiver X4

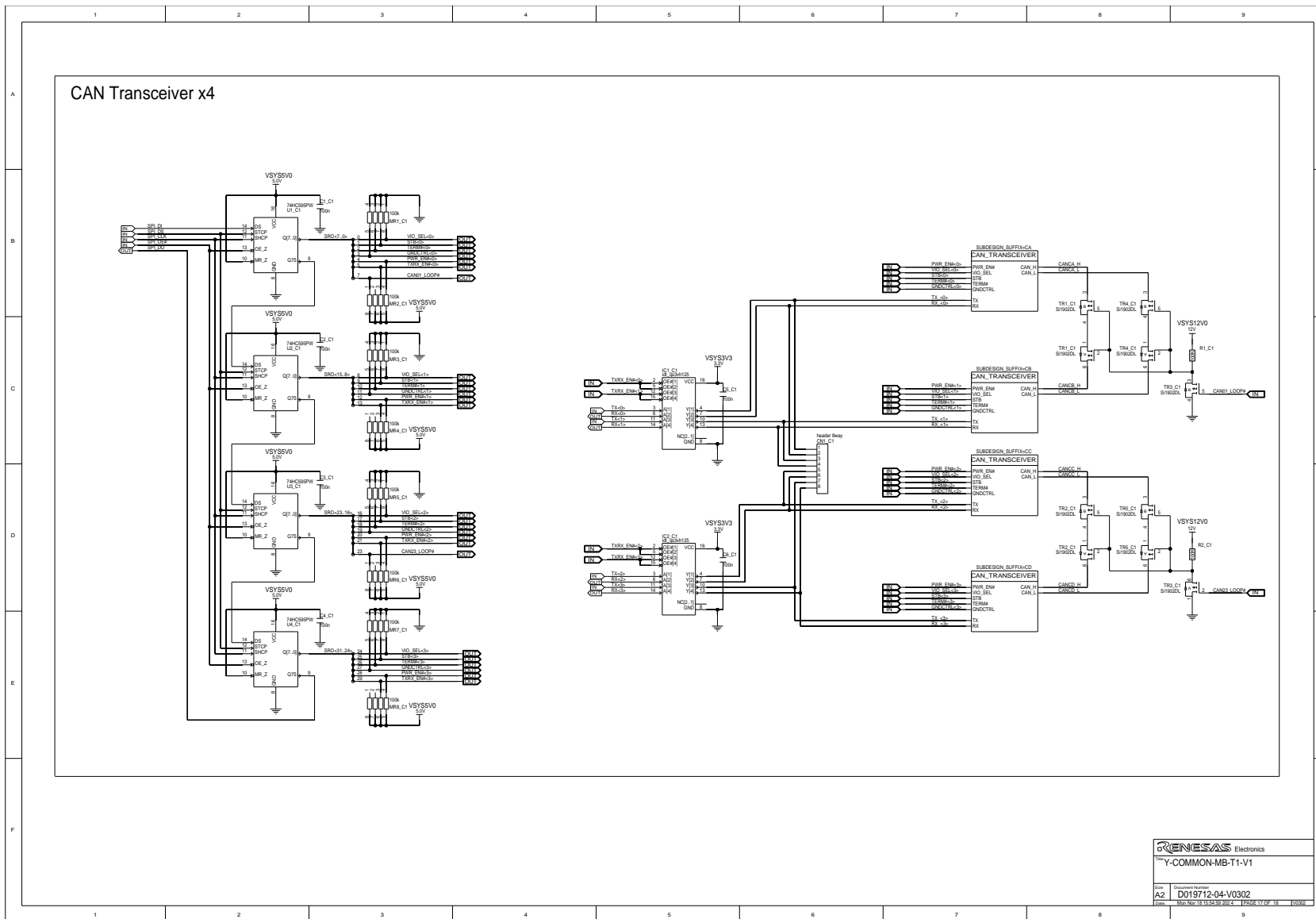

Y-COMMON-MB-T1-V1	
Date	Document Number
A2	D019712-04-V0302
Date	Rev. No. 18 (15SEP2024) (1509) 17 of 18 (10/2024)

8.3.18 Page 18: CAN Transceiver

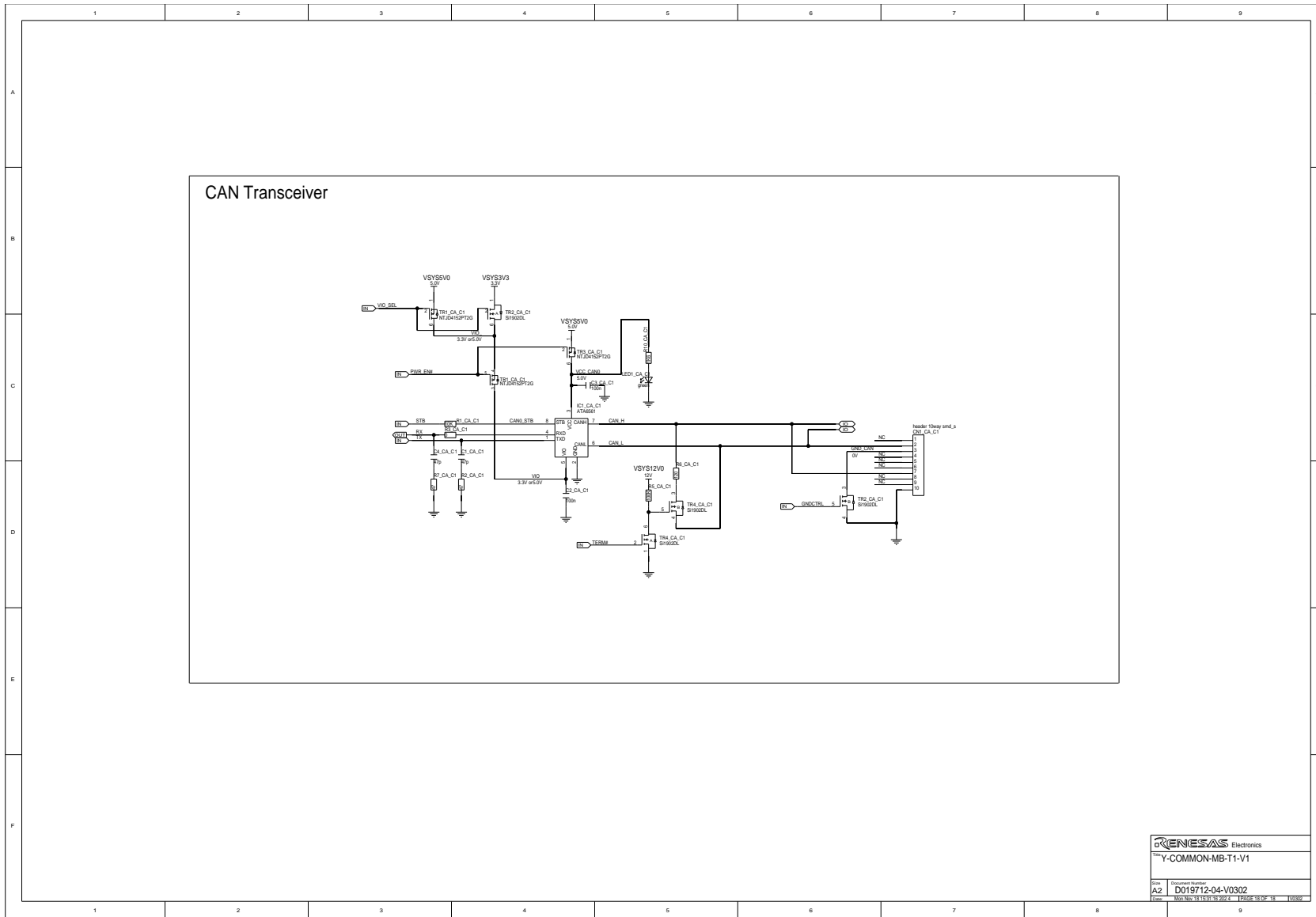

Y-COMMON-MB-T1-V1	
Date: A2	Document Number: D019712-04-V0302
Date:	Rev. No: 1815-01B-p02 1/25 Rev. 11 of 18 10/2019

8.4 Board Version D019712_06_V04

8.4.1 Page 1: Table of Contents

Y-COMMON-MB-T1-V1

Table of Contents	
Page No.	Page Name
1	Table of Contents
2	Power Supply
3	Voltage-/Signal LEDs / IIC0 / Board Configurator
4	LIN / SENT Interfaces
5	UART Interfaces
6	CAN (XL) Interfaces
7	FlexRay Interfaces
8	Ethernet / SD-Card / SFMA / I2S Interfaces
9	Encoder / LED CSI Driver
10	Display / Interrupt / AD Measurement
11	Resolver
12	Motor
13	PMOD Interfaces
14	Piggyback Connectors / Multiplexer
15	LIN Transceiver X4
16	LIN Transceiver
17	CAN Transceiver X4
18	CAN Transceiver

REV	COMMENT	DATE	DRAWN BY
V0100	Initial release	18.07.2023	FR
V0104	D019712_04_S03_V0104_y_common_mb_t1_v1_RevisionHistory.txt	14.11.2023	FR
V0105	D019712_04_S03_V0105_y_common_mb_t1_v1_RevisionHistory.txt	05.12.2023	FR
V0200	D019712_04_S03_V0200_y_common_mb_t1_v1_RevisionHistory.txt	06.12.2023	FR/LS
V0202	D019712_04_S03_V0202_y_common_mb_t1_v1_RevisionHistory.txt	22.02.2024	FR/LS/ME
V0301	D019712_04_S03_V0301_y_common_mb_t1_v1_RevisionHistory.txt	21.11.2024	ME
V0302	D019712_04_S03_V0302_y_common_mb_t1_v1_RevisionHistory.txt	26.02.2025	ME
V0400	D019712_04_S03_V0400_y_common_mb_t1_v1_RevisionHistory.txt	10.06.2025	ME

Title: Y-COMMON-MB-T1-V1
 Size: A3 Document Number: D019712-04-V0400
 Date: Tue Jun 10 13:41:51 2025 | PAGE 1 OF 18 | V0400

8.4.2 Page 2: Power Supply

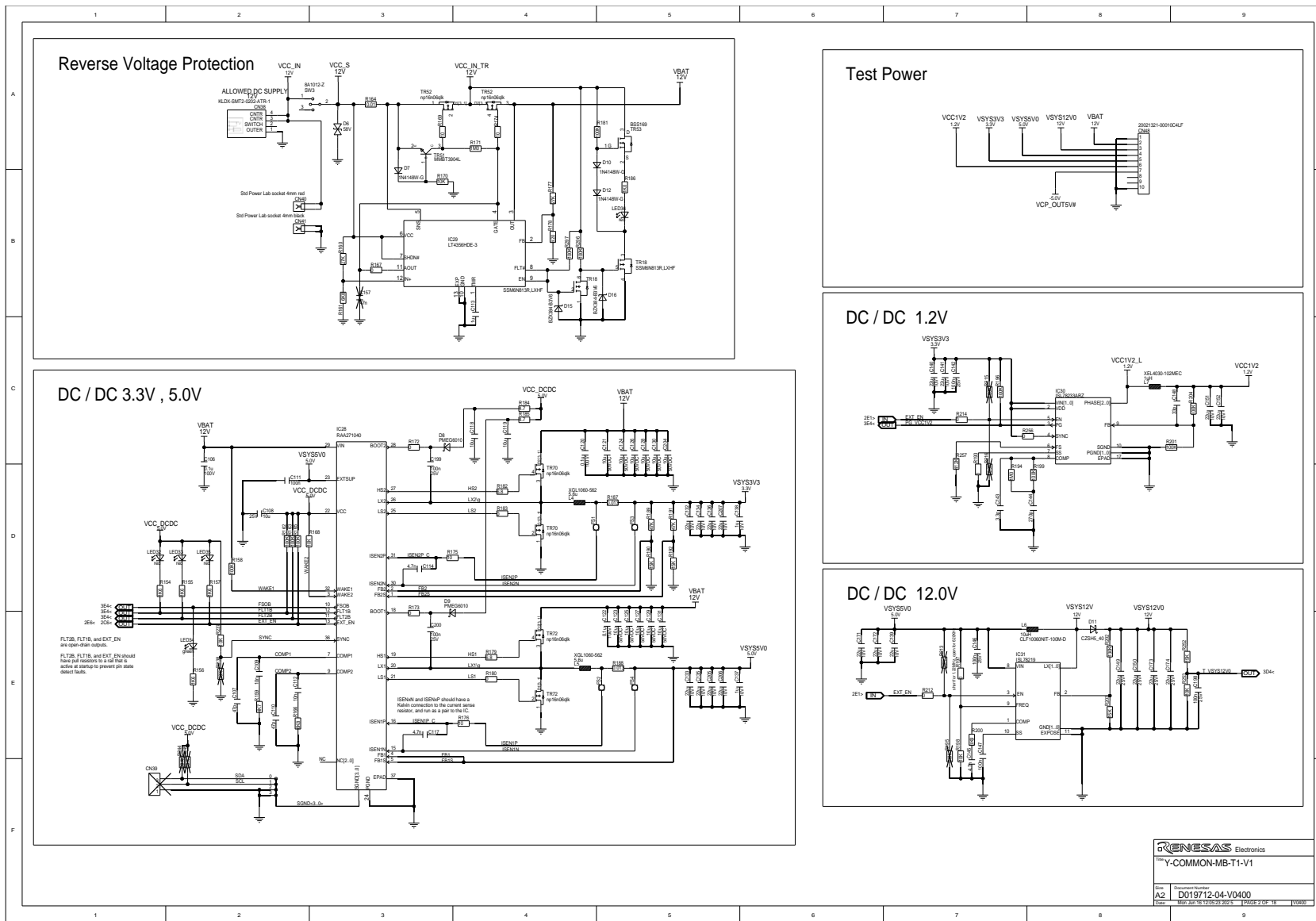

8.4.3 Page 3: Voltage-/Signal LEDs / IIC0 / Board Configurator

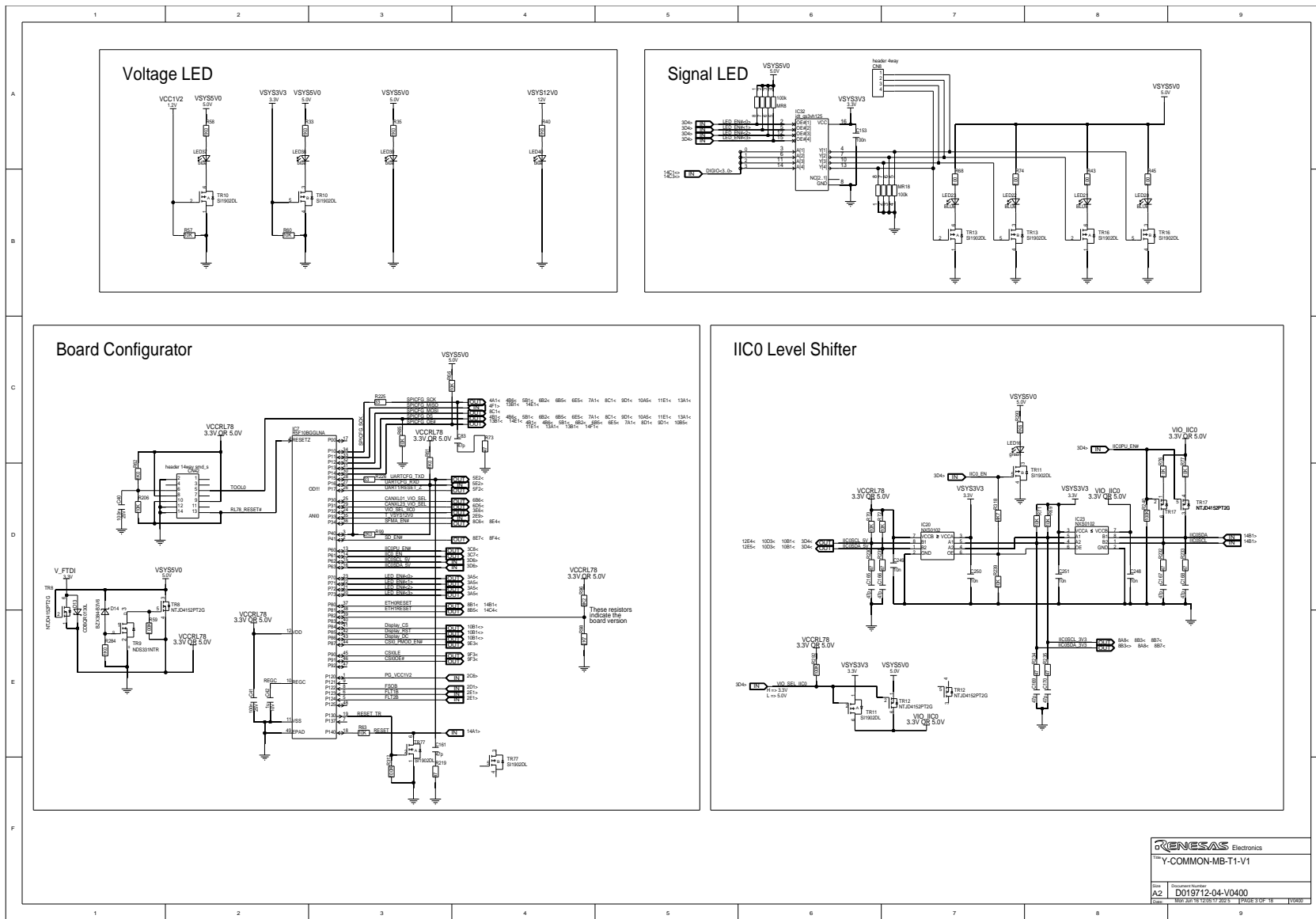

8.4.4 Page 4: LIN / SENT Interfaces

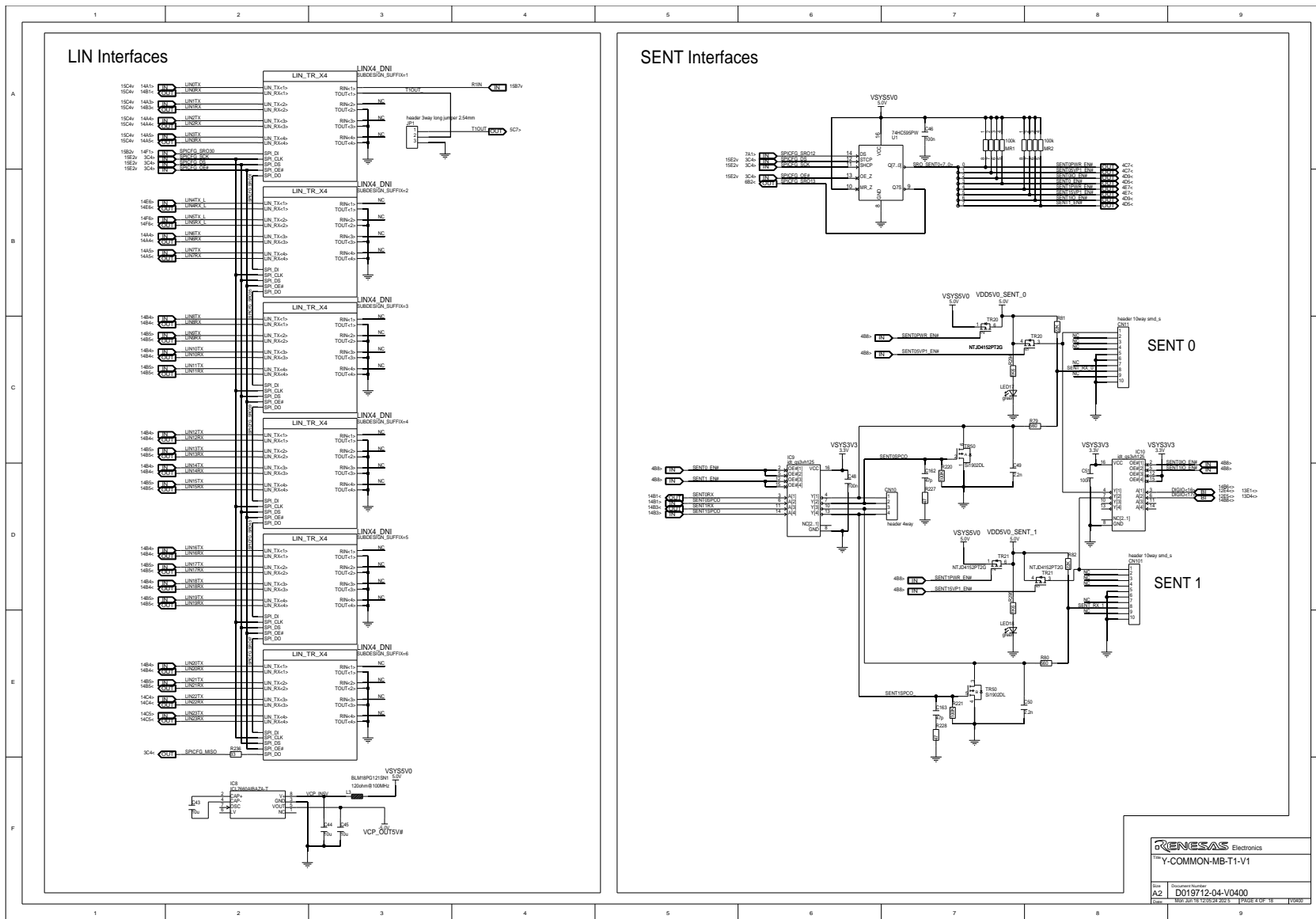

RENESESAS Electronics
Y-COMMON-MB-T1-V1
Rev. A2
Docu. Number: D019712-04-V0400
Date: Mar 2019 16:23:52 J203 1 Page 4 of 18 10980

8.4.5 Page 5: UART Interfaces

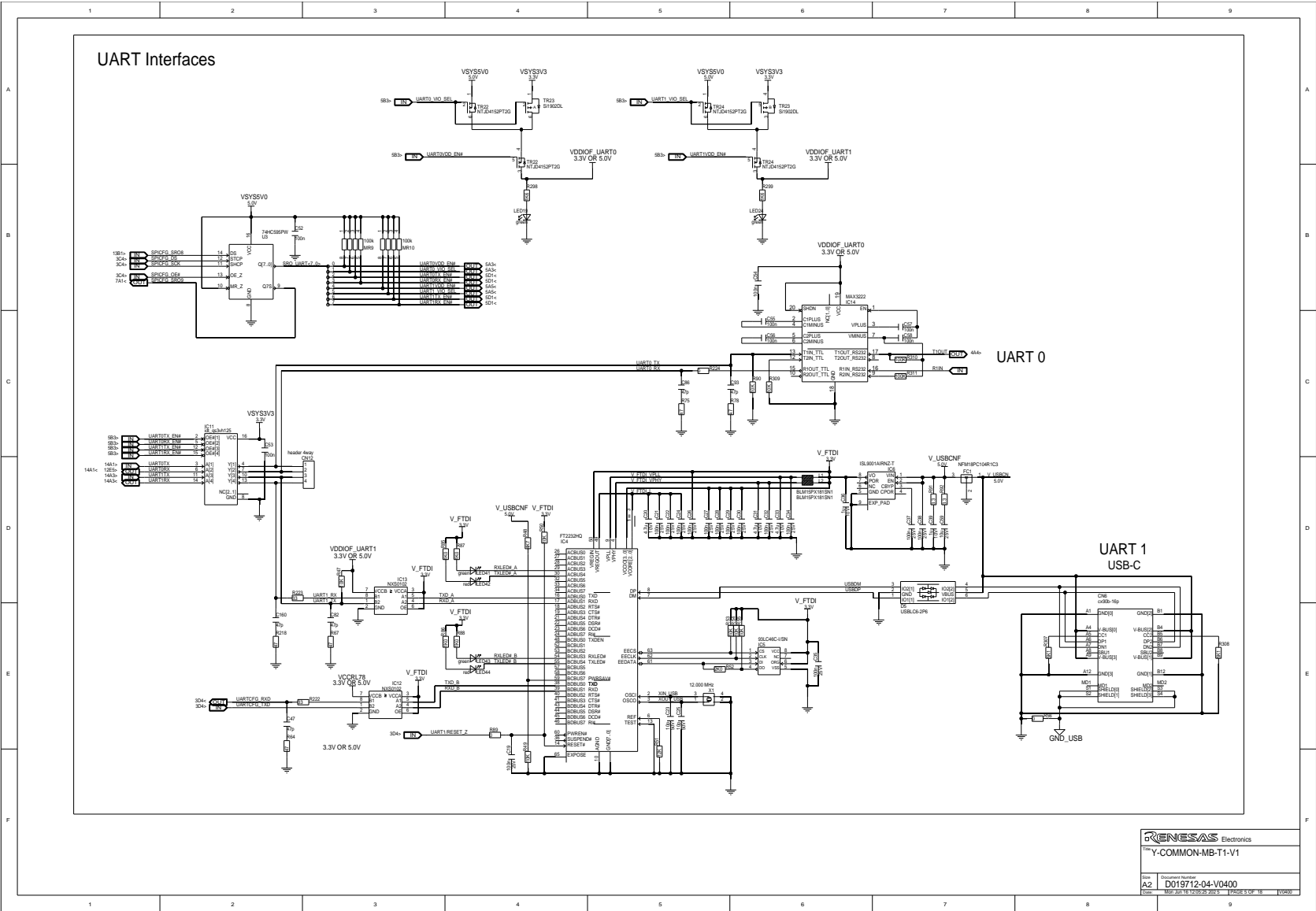

8.4.6 Page 6: CAN (XL) Interfaces

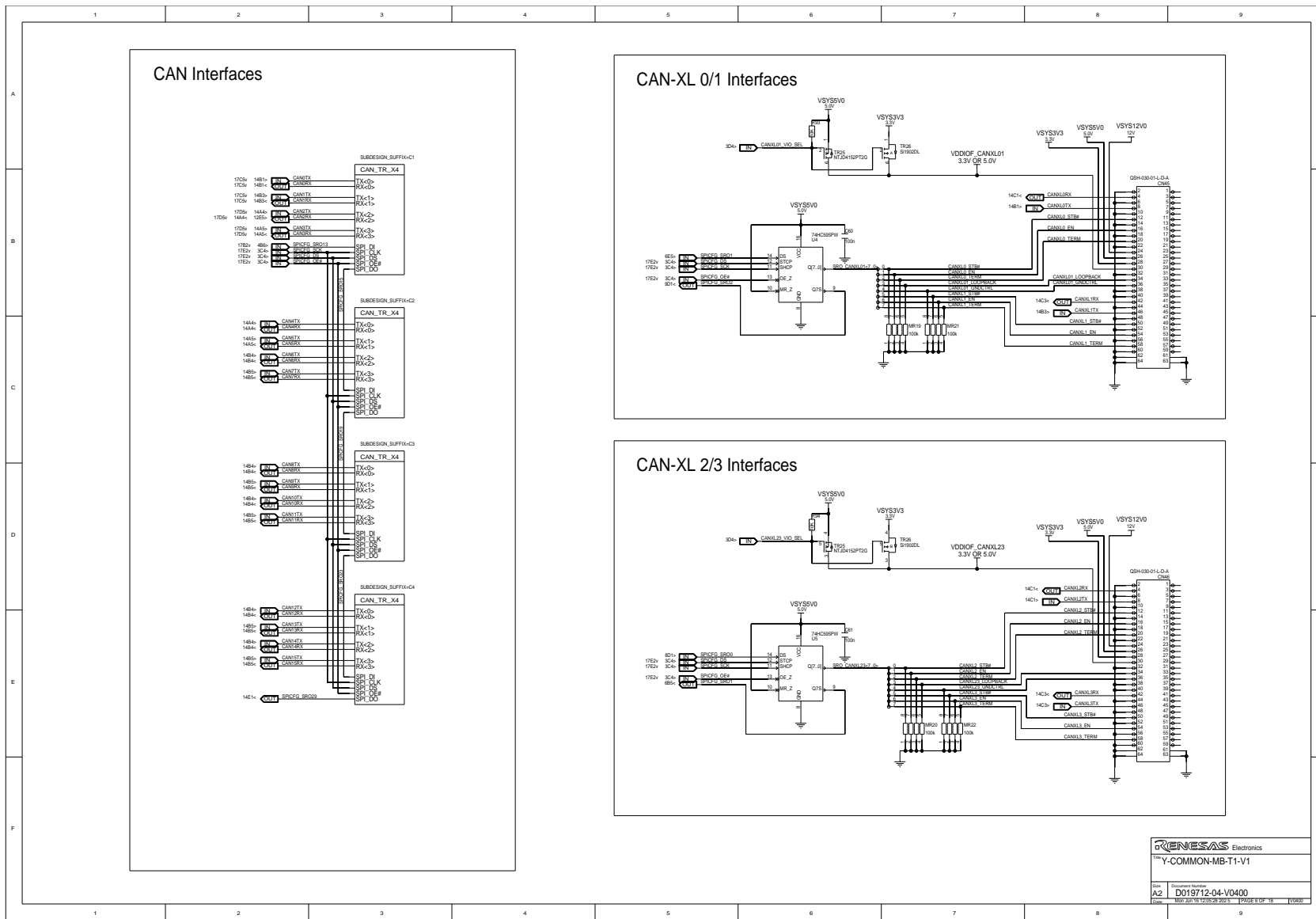

RENESAS Electronics

 Y-COMMON-MB-T1-V1

 Rev. A.2

 Document Number: D019712-04-V0400

 Date: Mar 2019 16:23:28 JST 5 1 PAGE 6 OF 18 109895

8.4.7 Page 7: FlexRay Interfaces

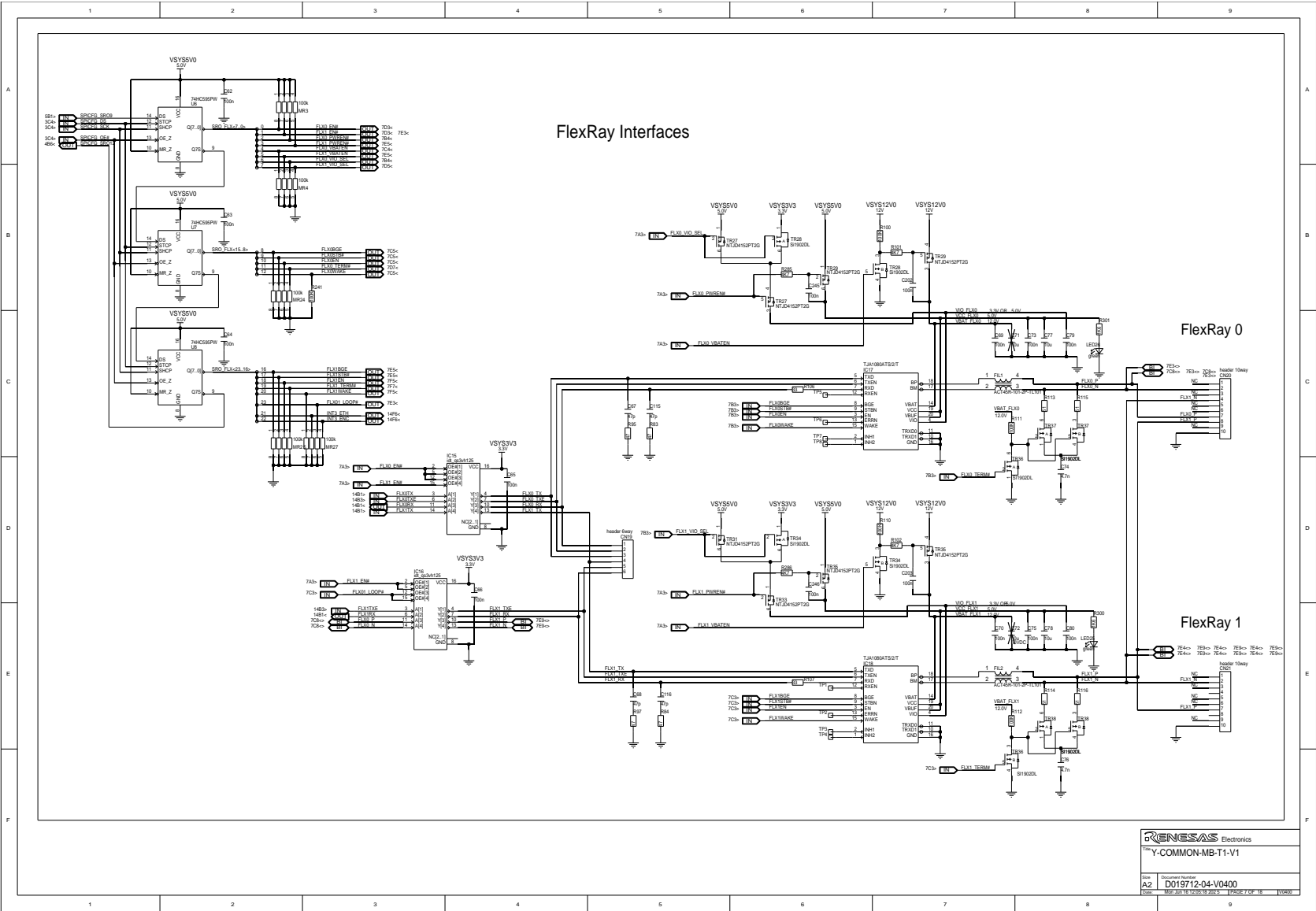

8.4.10 Page 10: Display / Interrupt / A/D Measurement

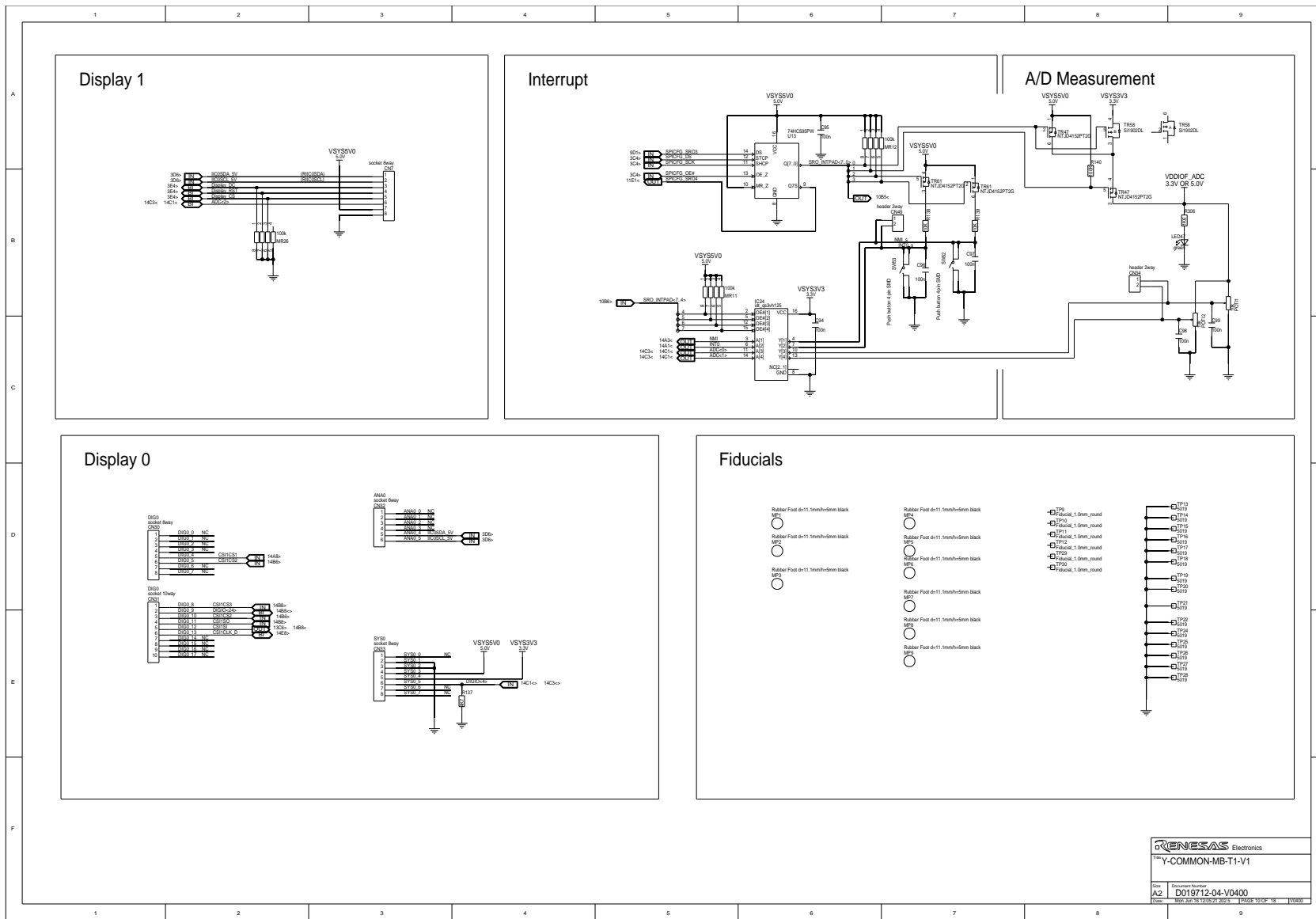

RENEASAS Electronics

 Y-COMMON-MB-T1-V1

 Rev. A.2

 Document Number: D019712-04-V0400

 Date: Mar 2019 16:23:57 JST 5 1 Page 19 of 18 100000

8.4.11 Page 11: Resolver

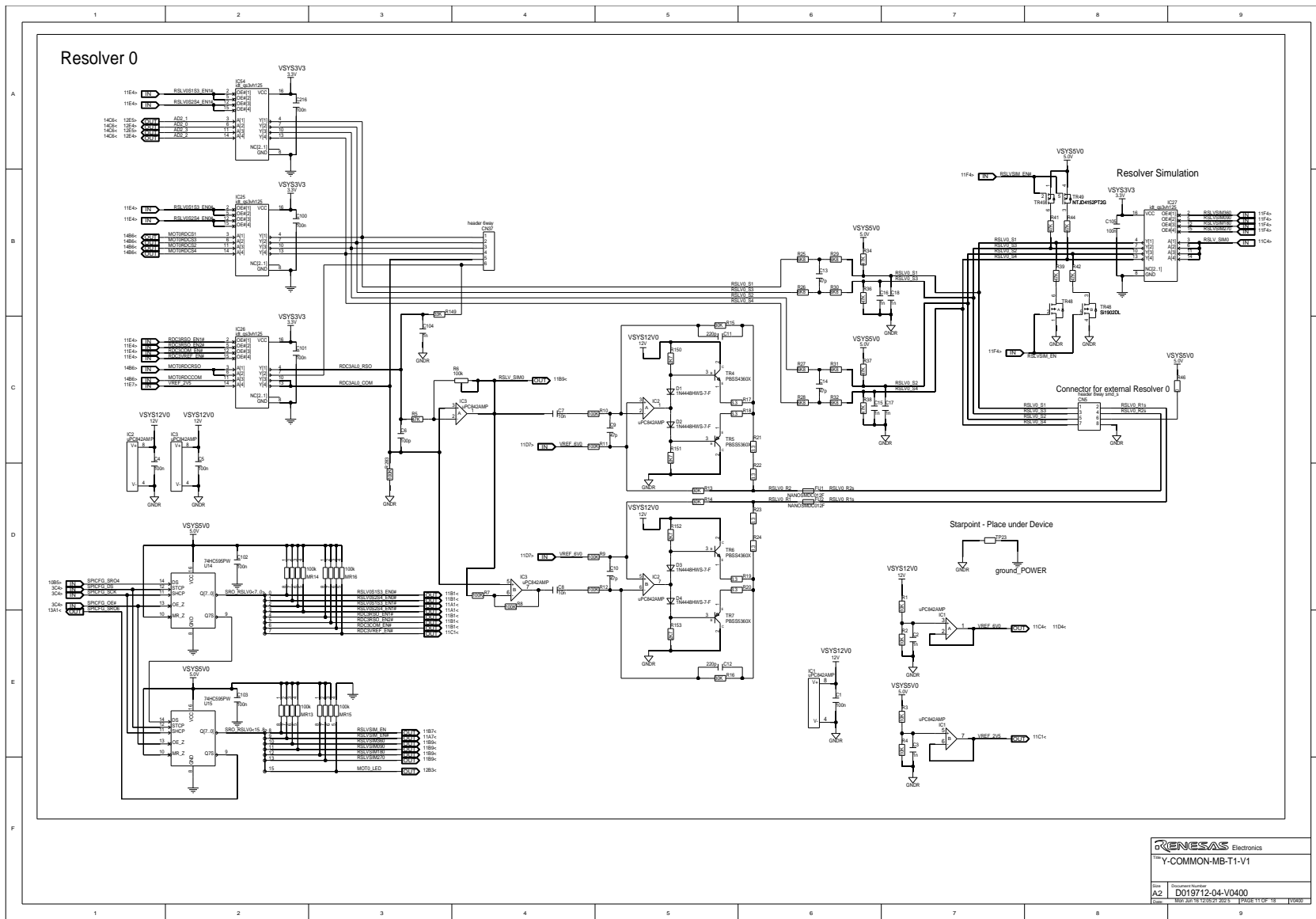

Y-COMMON-MB-T1-V1	
Rev.	Document Number
A.2	D019712-04-V0400
Date	Mar 2016 16:25:57 J253 1/PAGE 11 OF 18 109850

8.4.12 Page 12: Motor

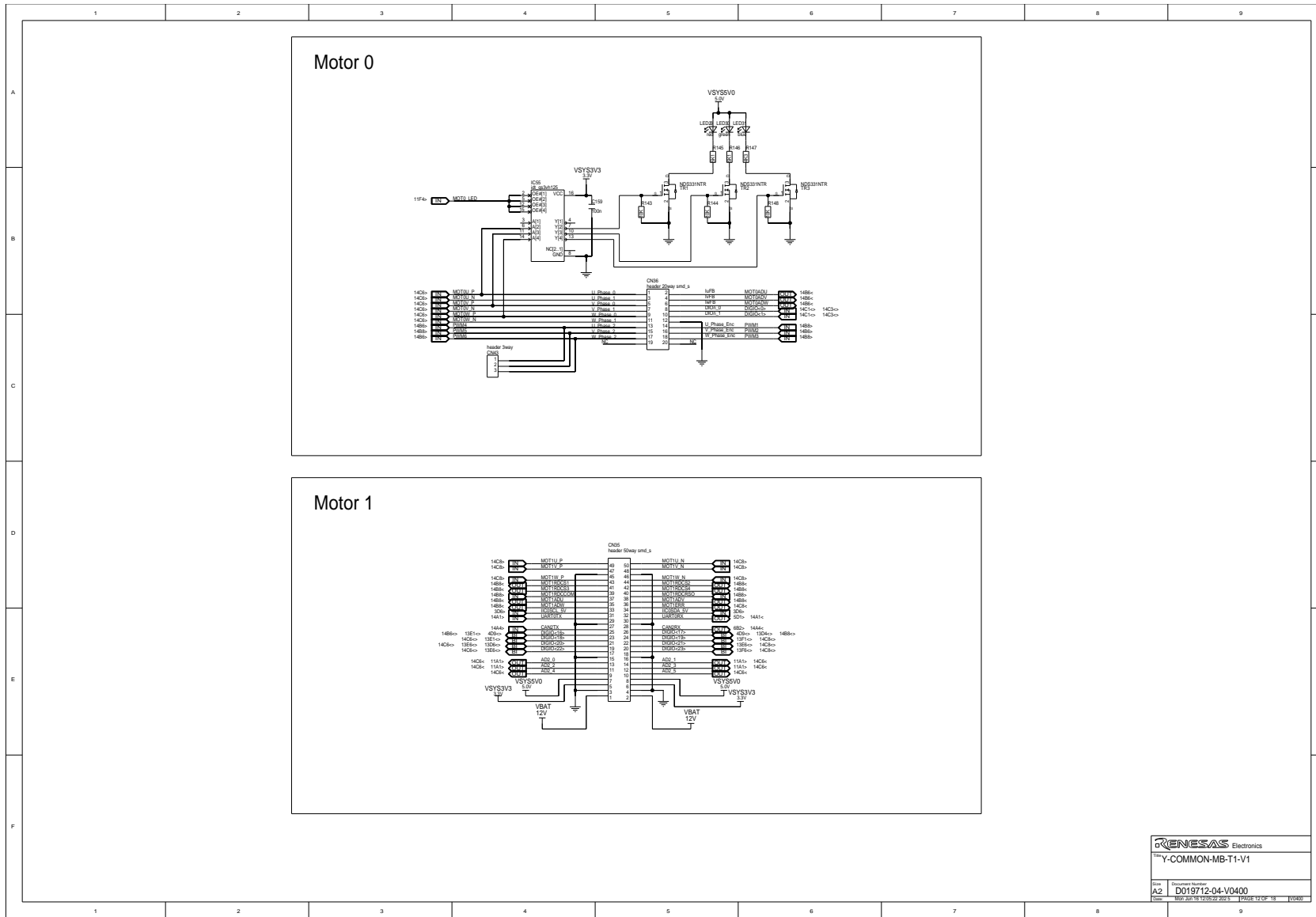

Y-COMMON-MB-T1-V1

 Doc. No. D019712-04-V0400

 Date: Mar 2016 12:05:22 JST 1/ Page 12 of 18 10/400

8.4.16 Page 16: LIN Transceiver

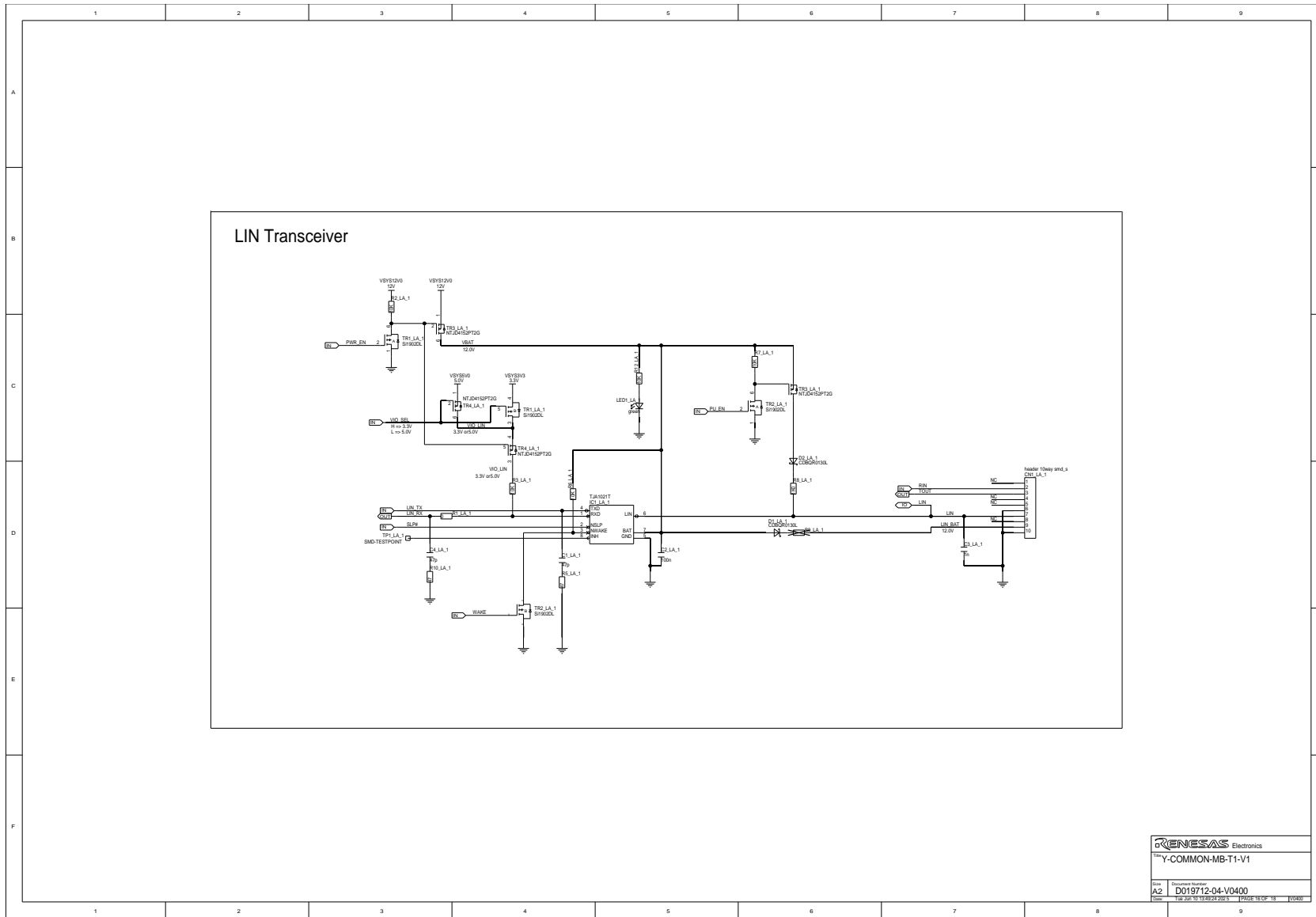

RENESAS Electronics	
Y-COMMON-MB-T1-V1	
Rev.	Document Number
A2	D019712-04-V0400
Date	Thu Jul 15 11:57:21 2022 1/2 Page 16 of 18 100400

8.4.17 Page 17: CAN Transceiver X4

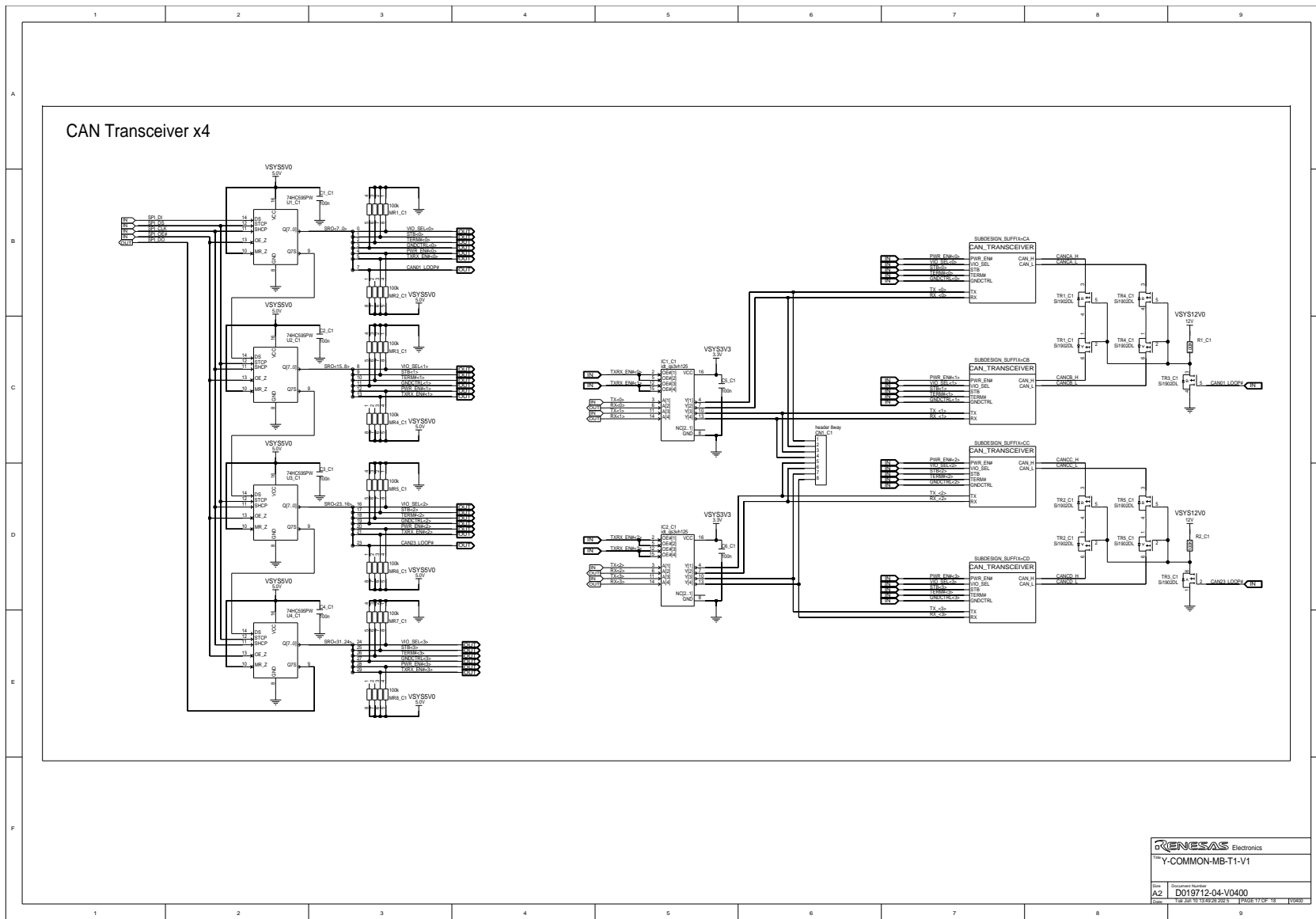

Y-COMMON-MB-T1-V1	
Rev.	Document Number
A.2	D019712-04-V0400
Date	Tue Jul 19 11:57:28 2016 1/ PAGE 17 OF 18 109561

8.4.18 Page 18: CAN Transceiver

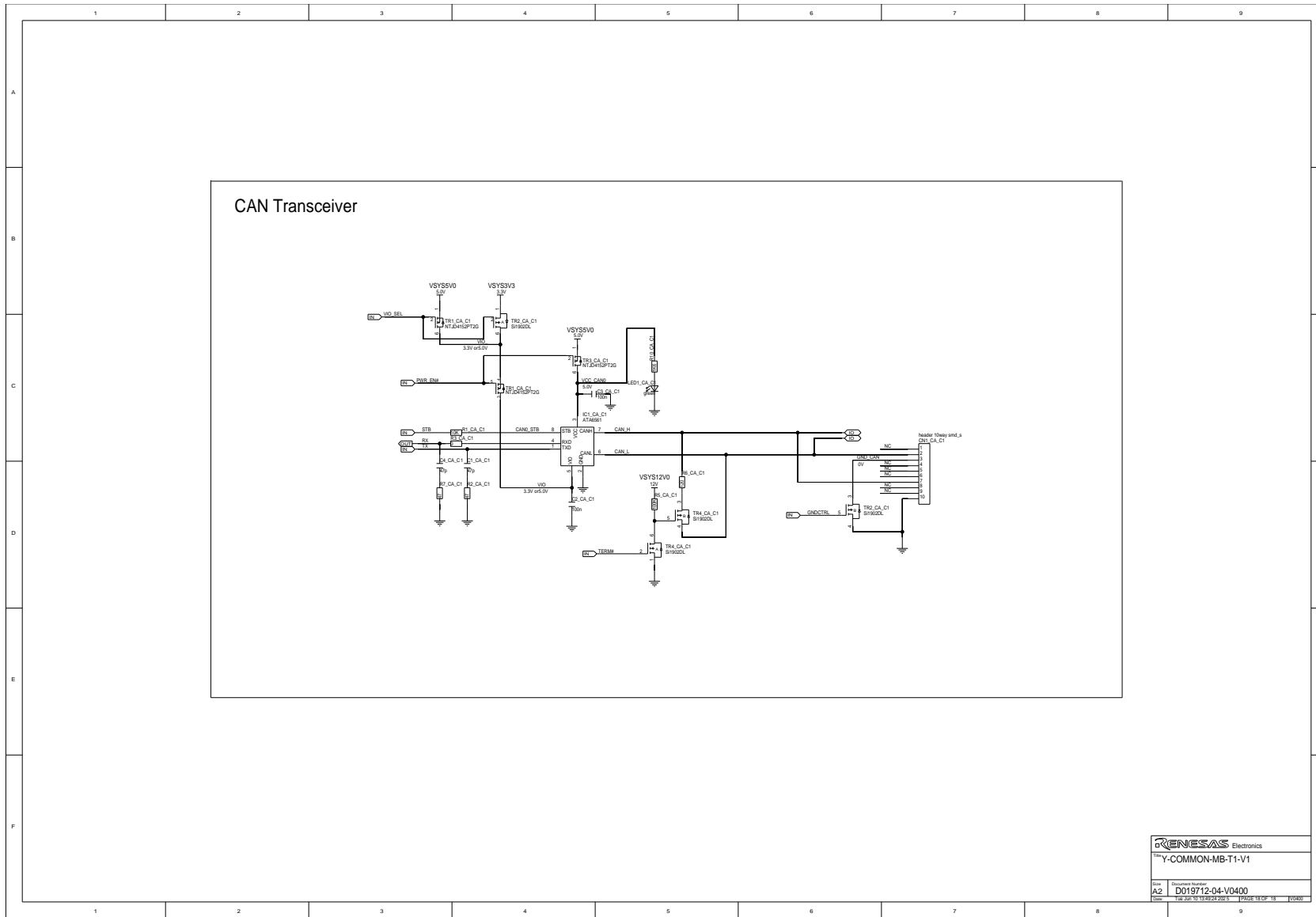

Revision History

Rev.	Date	Description	
		Page	Summary
V1.00	2024-01-10	–	Initial release (Hardware revision D019712_06_V01)
V2.00	2024-04-17	9	Revised hardware release (Hardware revision D019712_06_V02) Details are summarized in chapter <i>1.4 Main Board Versions</i>
		1	Added new product code Y-COMMON-MB-T1-V1-JP for Japan version of the main board.
V2.01	2024-11-28	61	Updated information for Ethernet extension modules in chapter <i>5.6 Ethernet Modules</i> .
		99	Added precaution about resolver signals in chapter <i>6.1 Resolver Circuit</i>
V3.00	2025-01-24	9	Revised hardware release (Hardware revision D019712_06_V03) Details are summarized in chapter <i>1.4 Main Board Versions</i>
		54	Updated information on CAN XL modules in chapter <i>5.4 CAN XL Modules</i> .
V3.01	2025-02-18	99	Added precaution <i>6.1 Resolver Circuit</i> .
V4.00	2025-10-17	9	Revised hardware release (Hardware revision D019712_06_V04)
		30, 56	Updated power supply circuit for FlexRay circuit in <i>3.4 Peripheral Supply Voltage VDDIOF</i> and in <i>5.5 FlexRay Interfaces</i>
V4.01	2026-03-30	66	Updated circuit diagram for Ethernet circuit in <i>5.6.1.4 Renesas Ethernet Board Y-COMMON-1000BASE-T1-88Q2112</i>
V4.02	2026-06-15	12	Removed extension board Y-RH850-CANFD-TJA1463 from Table 1.4 due to non-availability.
		54	Updated description for CAN XL boards in <i>5.4 CAN XL Modules</i> .
		67	Updated description for Ethernet T1S boards in <i>5.6.2 Ethernet Modules Supporting T1S</i> .
		91	Updated description for BLDC Motor Control Board in <i>5.16.1 Motor Control Extension Board Y-COMMON-BLDC-MOTOR-DRV</i>

Common Main Board for RH850 and R-Car U5x T1-V1 User's Manual

Publication Date: Rev.4.02 Jun 15, 2026

Published by: Renesas Electronics Europe



SALES OFFICES

Renesas Electronics Corporation

<http://www.renesas.com>

Refer to "<http://www.renesas.com/>" for the latest and detailed information.

Renesas Electronics America Inc.

1001 Murphy Ranch Road, Milpitas, CA 95035, U.S.A.
Tel: +1-408-432-8888, Fax: +1-408-434-5351

Renesas Electronics Canada Limited

9251 Yonge Street, Suite 8309 Richmond Hill, Ontario Canada L4C 9T3
Tel: +1-905-237-2004

Renesas Electronics Europe Limited

Dukes Meadow, Millboard Road, Bourne End, Buckinghamshire, SL8 5FH, U.K.
Tel: +44-1628-651-700, Fax: +44-1628-651-804

Renesas Electronics Europe GmbH

Arcadiastrasse 10, 40472 Düsseldorf, Germany
Tel: +49-211-6503-0, Fax: +49-211-6503-1327

Renesas Electronics (China) Co., Ltd.

Room 1709 Quantum Plaza, No.27 ZhichunLu, Haidian District, Beijing, 100191 P. R. China
Tel: +86-10-8235-1155, Fax: +86-10-8235-7679

Renesas Electronics (Shanghai) Co., Ltd.

Unit 301, Tower A, Central Towers, 555 Langao Road, Putuo District, Shanghai, 200333 P. R. China
Tel: +86-21-2226-0888, Fax: +86-21-2226-0999

Renesas Electronics Hong Kong Limited

Unit 1601-1611, 16/F., Tower 2, Grand Century Place, 193 Prince Edward Road West, Mongkok, Kowloon, Hong Kong
Tel: +852-2265-6688, Fax: +852 2886-9022

Renesas Electronics Taiwan Co., Ltd.

13F, No. 363, Fu Shing North Road, Taipei 10543, Taiwan
Tel: +886-2-8175-9600, Fax: +886 2-8175-9670

Renesas Electronics Singapore Pte. Ltd.

80 Bendemeer Road, Unit #06-02 Hyflux Innovation Centre, Singapore 339949
Tel: +65-6213-0200, Fax: +65-6213-0300

Renesas Electronics Malaysia Sdn.Bhd.

Unit 1207, Block B, Menara Amcorp, Amcorp Trade Centre, No. 18, Jln Persiaran Barat, 46050 Petaling Jaya, Selangor Darul Ehsan, Malaysia
Tel: +60-3-7955-9390, Fax: +60-3-7955-9510

Renesas Electronics India Pvt. Ltd.

No.777C, 100 Feet Road, HAL 2nd Stage, Indiranagar, Bangalore 560 038, India
Tel: +91-80-67208700, Fax: +91-80-67208777

Renesas Electronics Korea Co., Ltd.

17F, KAMCO Yangjae Tower, 262, Gangnam-daero, Gangnam-gu, Seoul, 06265 Korea
Tel: +82-2-558-3737, Fax: +82-2-558-5338

Common Main Board for
RH850 and R-Car/U5x



Renesas Electronics Corporation

R20UT5305ED0402