

REV	REF	DATE	DRAWN BY
1.00	Release	29.11.2019	KOS

Renesas Starter Kit+ for RX72N CPU Board Schematics

SHEET	DESCRIPTION
1	INDEX
2	RX72N Microcontroller-1
3	RX72N Microcontroller-2
4	RX72N Microcontroller-3
5	MCU Pin Function Select-1
6	MCU Pin Function Select-2
7	PSU
8	E1/E2 Lite Emulator, MCU & Emulator Mode Setting
9	Reset, Switches, LEDs
10	USB to Serial Interface
11	Pmod Interface, IIC EEPROM
12	Application Headers
13	SDRAM
14	SDHI
15	CAN, RSPI, QSPI, PDC, SSI
16	On-board TFT
17	USB (Host / Function)
18	Ethernet PHY
19	Ethernet Connector
20	Unused-Pin

Note:

C : Capacitor
D : Diode
J : Connector, Jumper
L : Inductor
LED : Light Emitting Diode
MR : Resistor Array
PWR : Power Jack
R : Fixed Resistor
RES : Reset Switch
RV : Potentiometer
SW : Switch
T : Test Point
U : Integrated Circuit
X : Crystal, Oscillator

* "DNF" marking means that component is not fitted by default.

**The following off-page connectors used in this schematics do not indicate the signal direction.



Board Code:

RTK5572NNDC00000BE : RSK+RX72N MP Board
 RTK5572NNHC00000BE : RSK+RX72N MP Board (Encryption version)

Abbreviations:

CAN : Controller Area Network
IIC : Philips(TM) Inter-Integrated Circuit Connection Bus
LED : Light Emitting Diode
MCU : Microcontroller Unit
PDC : Parallel Data Caputre Unit
PSU : Power Supply Unit
RSK : Renesas Starter Kit
SDHI : SD Host Interface
SSI : Serial Sound Interace
TFT : Thin Film Transistor
USB : Universal Serial Bus

REE Drawing No. D016482_04

Renesas Electronics Corporation			
Title RSK+RX72N [Index]			
Size	Document Number R20UT4435EG0100	Rev	1.00
Date:	Friday, November 29, 2019	Sheet	1 of 22

RX72N Microcontroller-1

Note:
Microcontroller's pins are not described by the full pin function.
For full pin functions details, refer to RX72N datasheet.

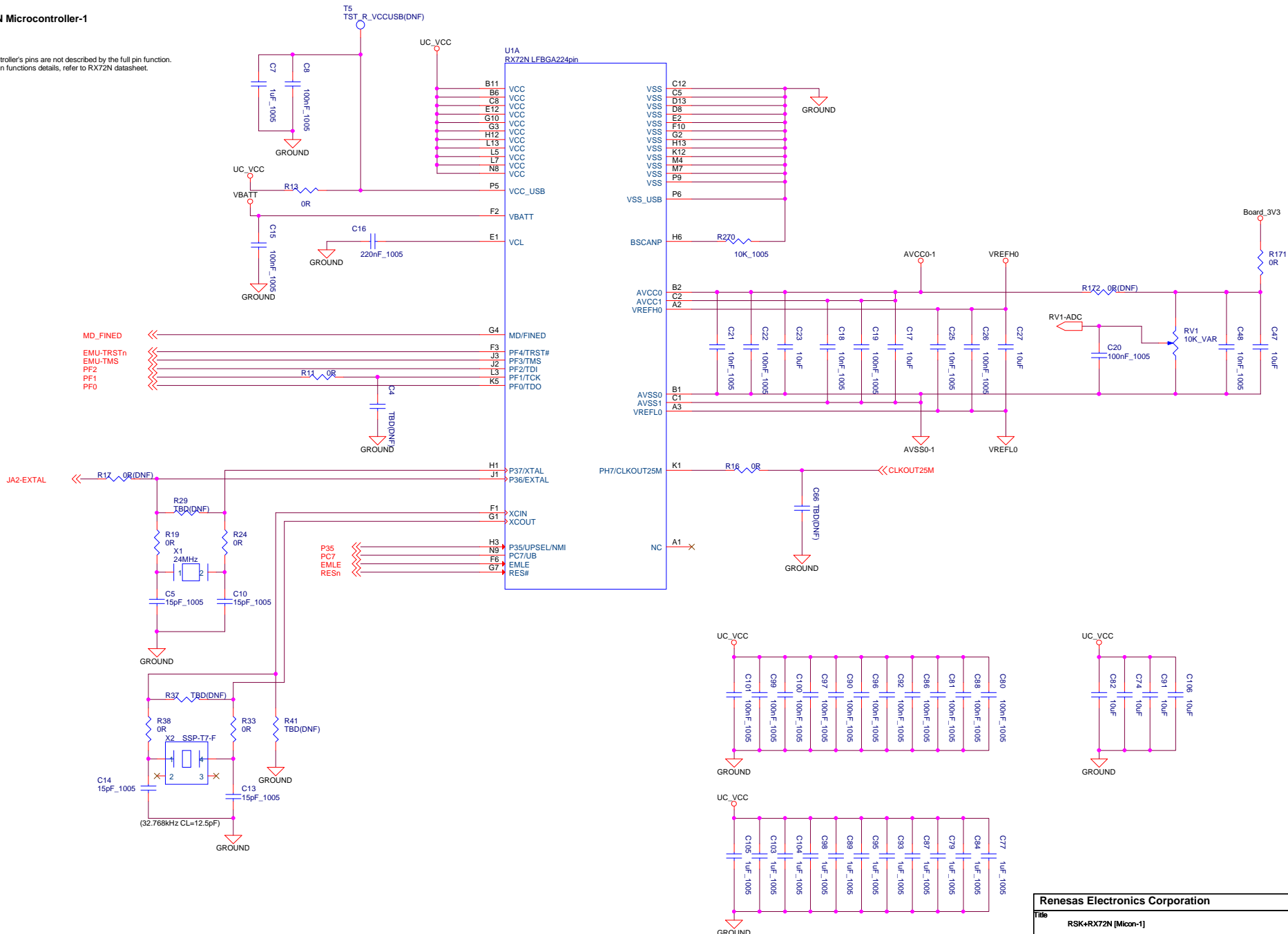

Renesas Electronics Corporation		
Title: RSK+RX72N [Micon-1]		
Size: R20UT4435EG0100	Rev: 1.00	
Date: Friday, November 29, 2019	Sheet: 2	of 22

RX72N Microcontroller-2

Note:
 Microcontroller's pins are not described by the full pin function.
 For full pin functions details, refer to RX72N datasheet.

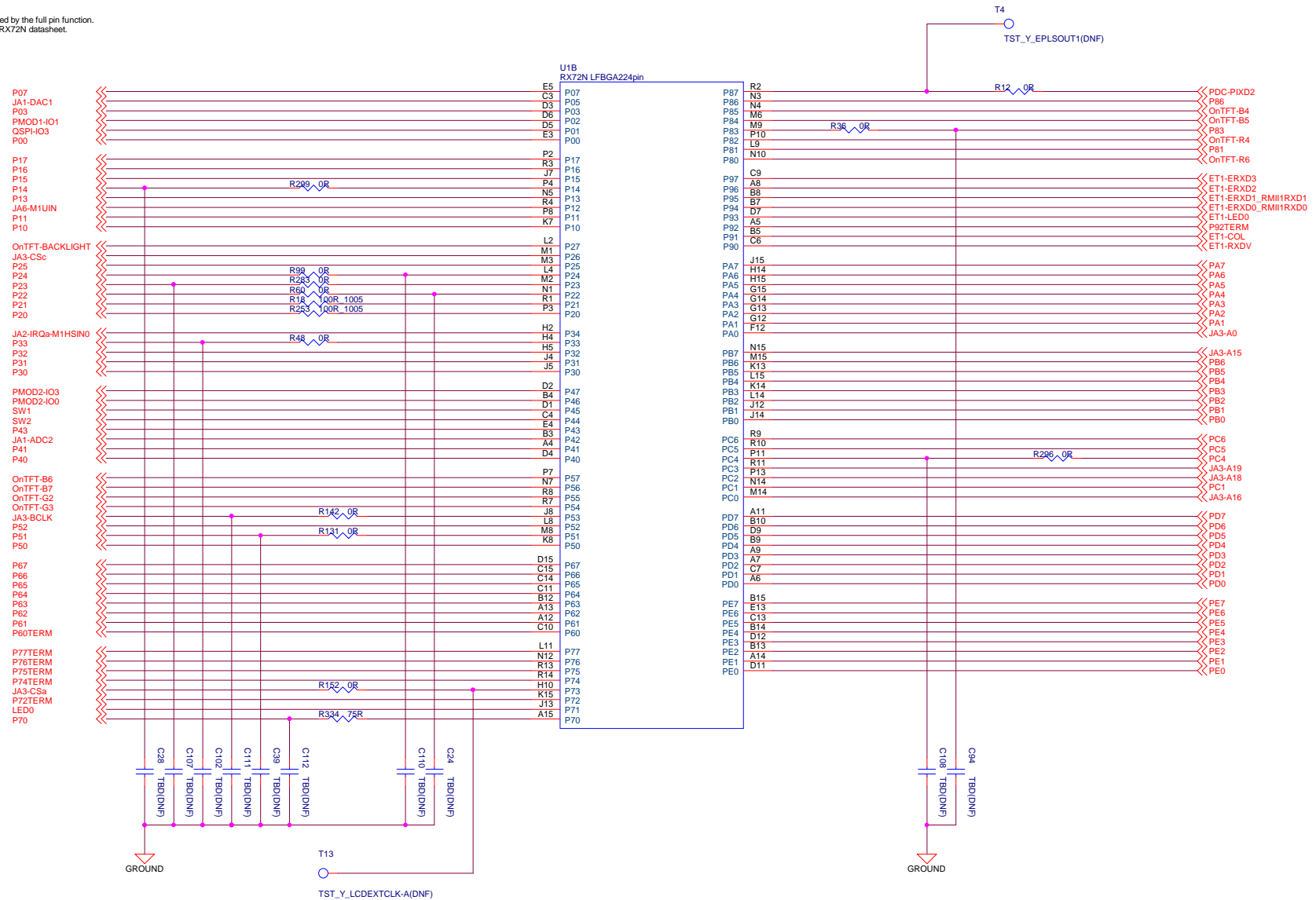

Renesas Electronics Corporation		
Title: RSK+RX72N [Micon-2]		
Size:	Document Number: R20UT4435EG0100	Rev: 1.00
Date: Friday, November 29, 2019	Sheet: 3 of 22	Page: 1

RX72N Microcontroller-3

Note:

Microcontroller's pins are not described by the full pin function.
For full pin functions details, refer to RX72N datasheet.

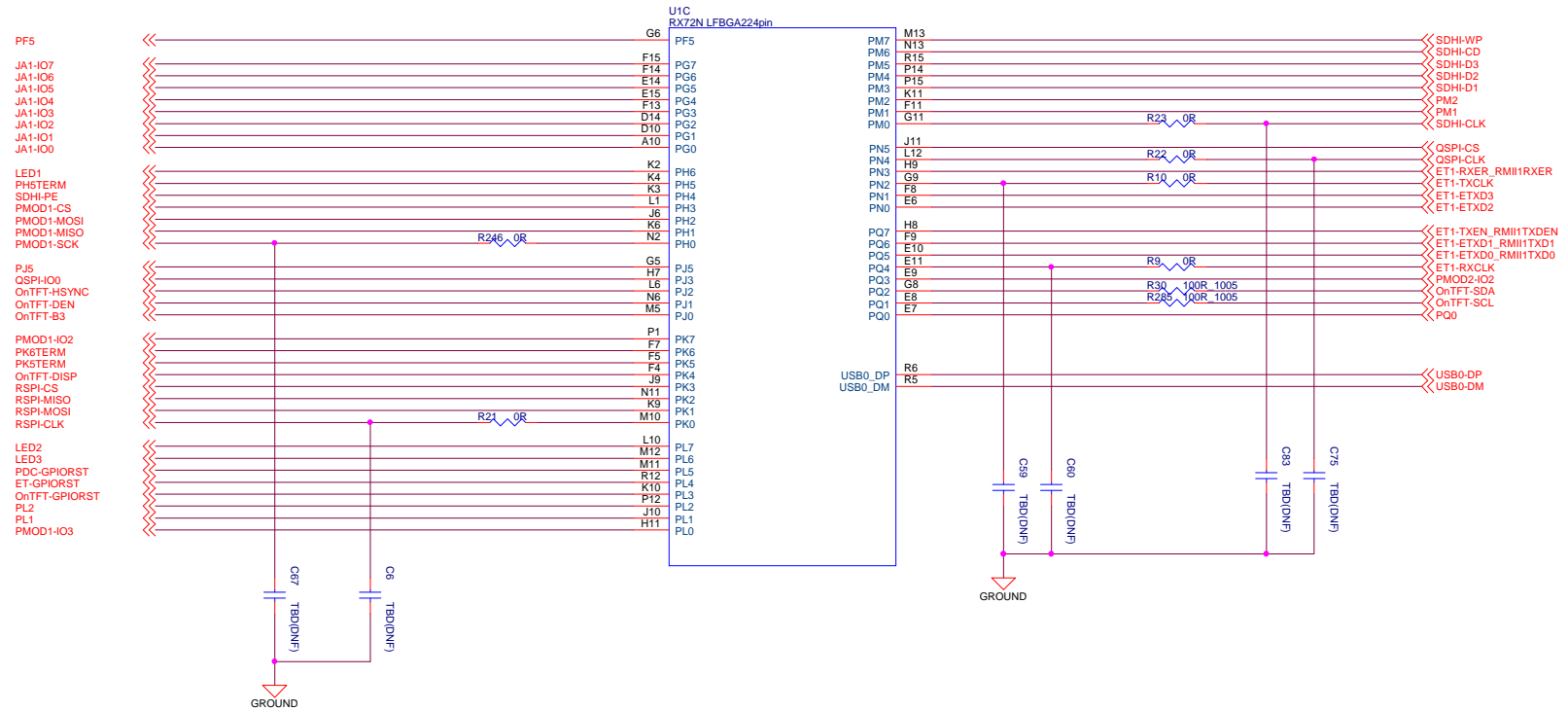

MCU Pin Function Select-1

AVCC0 (Pin B2), AVCC1 (Pin C2)

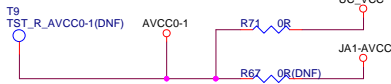

AVSS0 (Pin B1), AVSS1 (Pin C1)

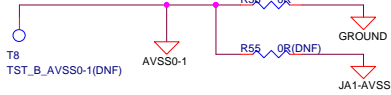

VREFH0 (Pin A2)

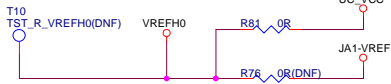

VREFL0 (Pin A3)

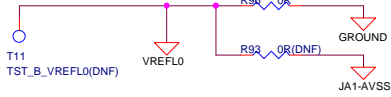

RES# (Pin G7)



PL5 (Pin M11)



PL3 (Pin K10)



EMLE (Pin F6)



MD_FINED (Pin G4)



P07 (Pin E5)



P03 (Pin D3)

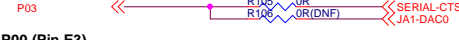

P00 (Pin E3)



P17 (Pin P2)



P16 (Pin R3)

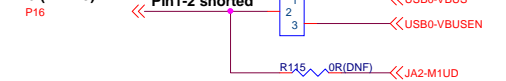

P15 (Pin J7)



P14 (Pin P4)

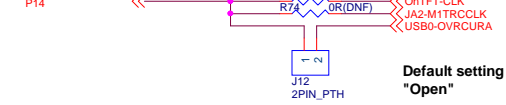

P13 (Pin N5)



P11 (Pin P8)



P10 (Pin K7)



P25 (Pin M3)

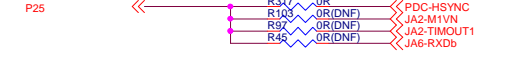

P24 (Pin L4)

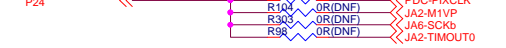

P23 (Pin M2)



P22 (Pin N1)

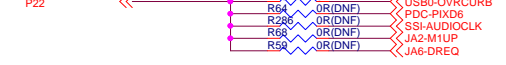

P21 (Pin R1)



P20 (Pin P3)

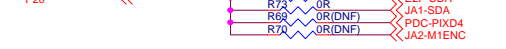

P35 (Pin H3)



P33 (Pin H4)



P32 (Pin H5)

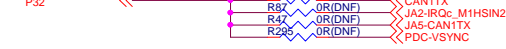

P31 (Pin J4)



P30 (Pin J5)



P43 (Pin E4)



P41 (Pin A4)



P40 (Pin D4)



P52 (Pin L8)



P51 (Pin M8)



P50 (Pin K8)



P67 (Pin D15)



P66 (Pin C15)



P65 (Pin C14)



P64 (Pin C11)



P63 (Pin B12)



P62 (Pin A13)



P61 (Pin A12)



P70 (Pin A15)



P86 (Pin N3)

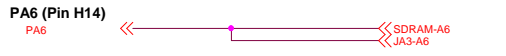

P83 (Pin M9)



P81 (Pin L9)



PA7 (Pin J15)



PA6 (Pin H14)



PA5 (Pin H15)

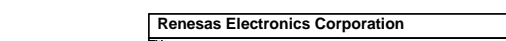

PA4 (Pin G15)

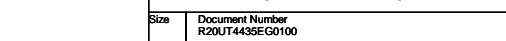

PA3 (Pin G14)



PA2 (Pin G13)

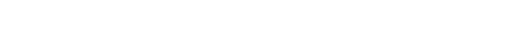

PA1 (Pin G12)

Renesas Electronics Corporation		
Title RSK+RX72N [MCU Pin Function Select-1]		
Size	Document Number R20UT4435EG0100	Rev 1.00
Date:	Friday, November 29, 2019	Sheet 5 of 22

MCU Pin Function Select-2

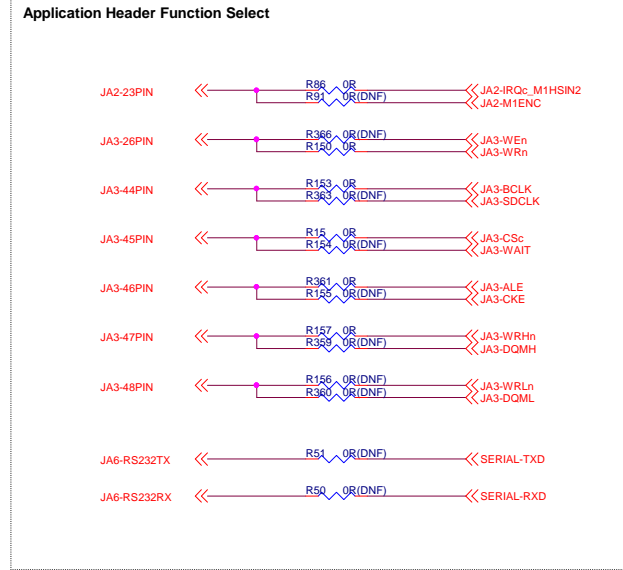
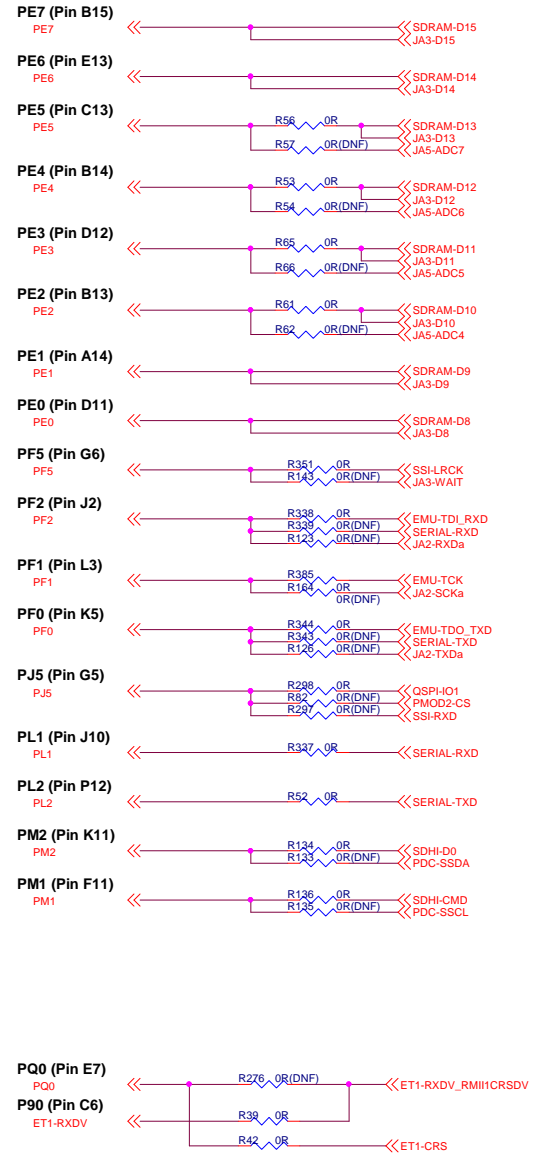
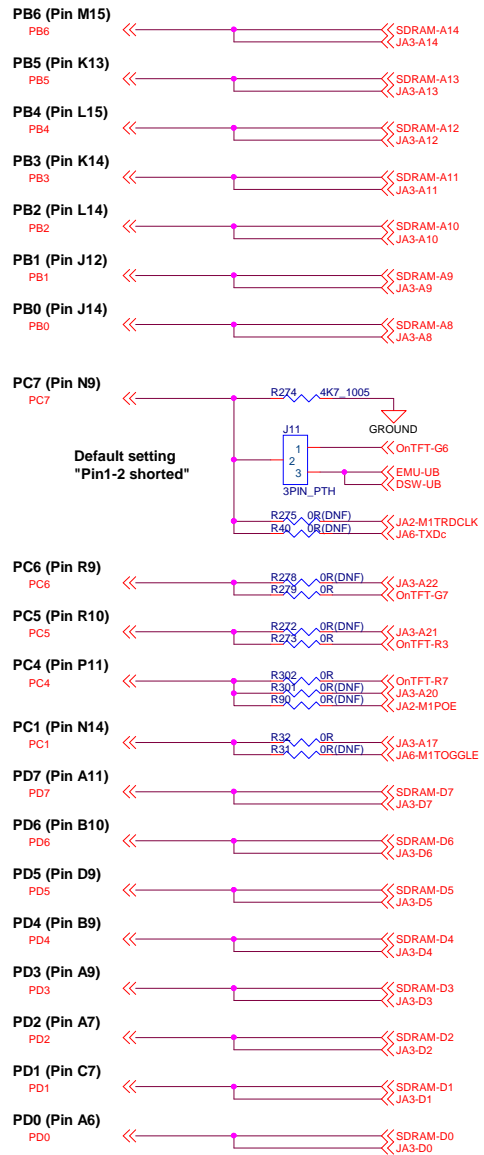

Power Supply Unit

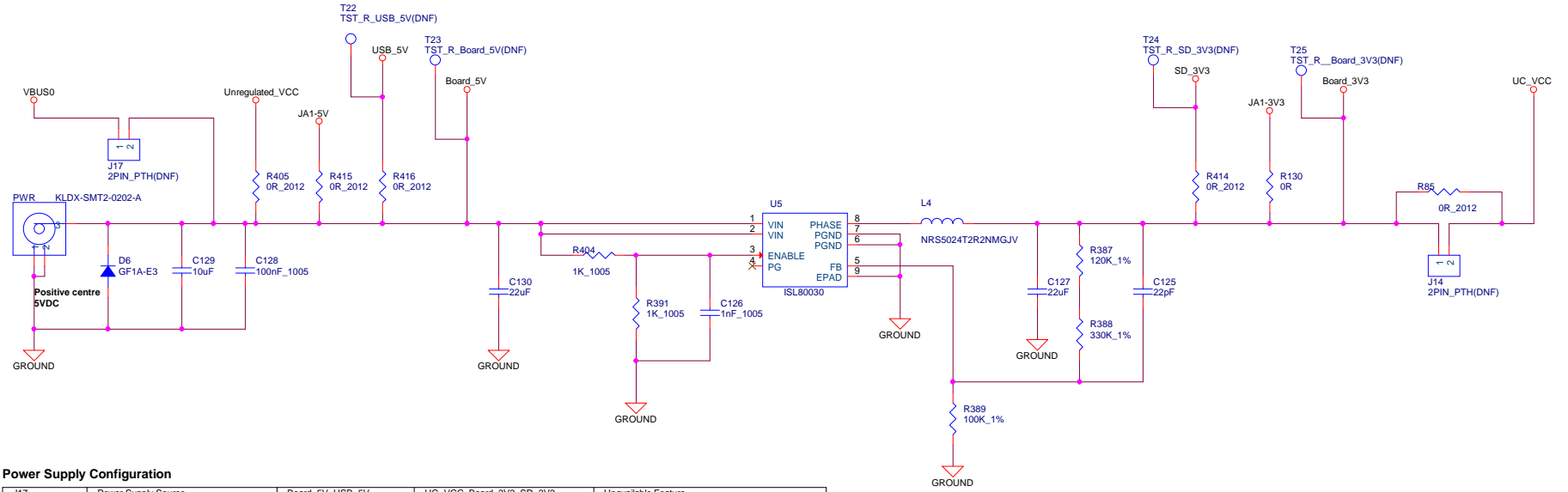

Power Supply Configuration

J17	Power Supply Source	Board_5V, USB_5V	UC_VCC, Board_3V3, SD_3V3	Unavailable Feature
open	PWR / Unregulated_VCC / JA1-5V	5V	3.3V	USB (Function-Buspowered)
shorted pin	VBUS	5V	3.3V	USB (Host), USB (Function-Selfpowered)

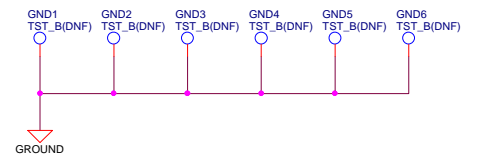
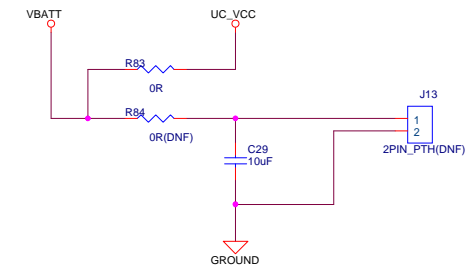

E1/E2 Lite Emulator Interface

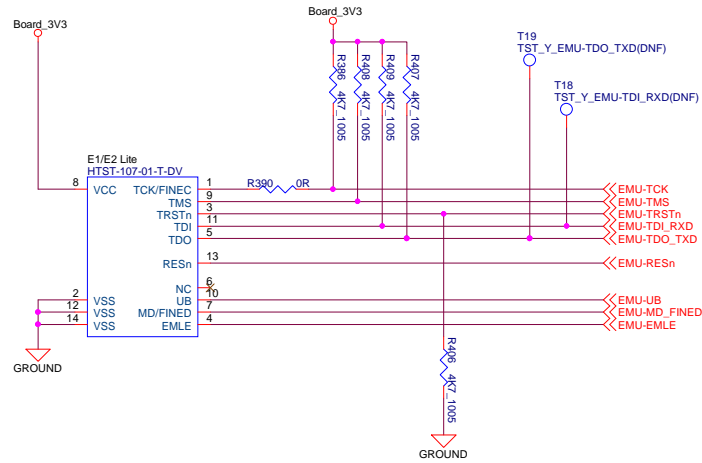

MCU & Emulator Mode Setting

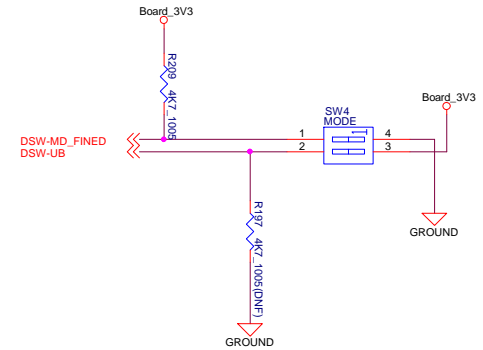

MCU Operating Mode Configuration

SW4 Pin1	SW4 Pin2	J15	Operating Mode
OFF	Don't care	Don't care	Single Chip Mode
ON	OFF	Don't care	SCI Boot Mode
ON	ON	Open	USB Boot Mode (Bus Powered)
ON	ON	Shorted Pin	USB Boot Mode (Self Powered)

Default setting of SW4.

SW4	Default
Pin1	OFF
Pin2	OFF

Emulator Configuration

J16	Emulator Configuration
Shorted Pin1-2	E1/E2 Lite normal debugging
Shorted Pin2-3	Microcontroller single operation (without emulator)
All open	E1/E2 Lite debugging with Hot plug-in
	DO NOT SET

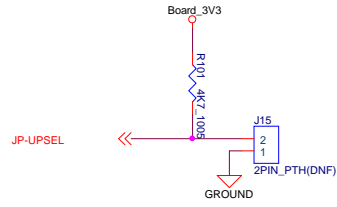
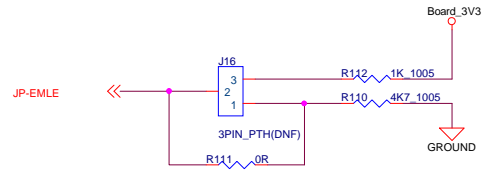

Power Configuration for USB Boot Mode

J15	Power Configuration
Open	Bus Powered
Shorted	Self Powered

Option pull-up resistor

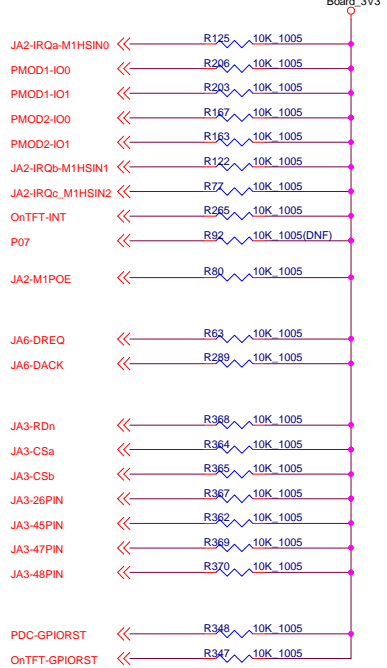

Switches, LEDs, RESET

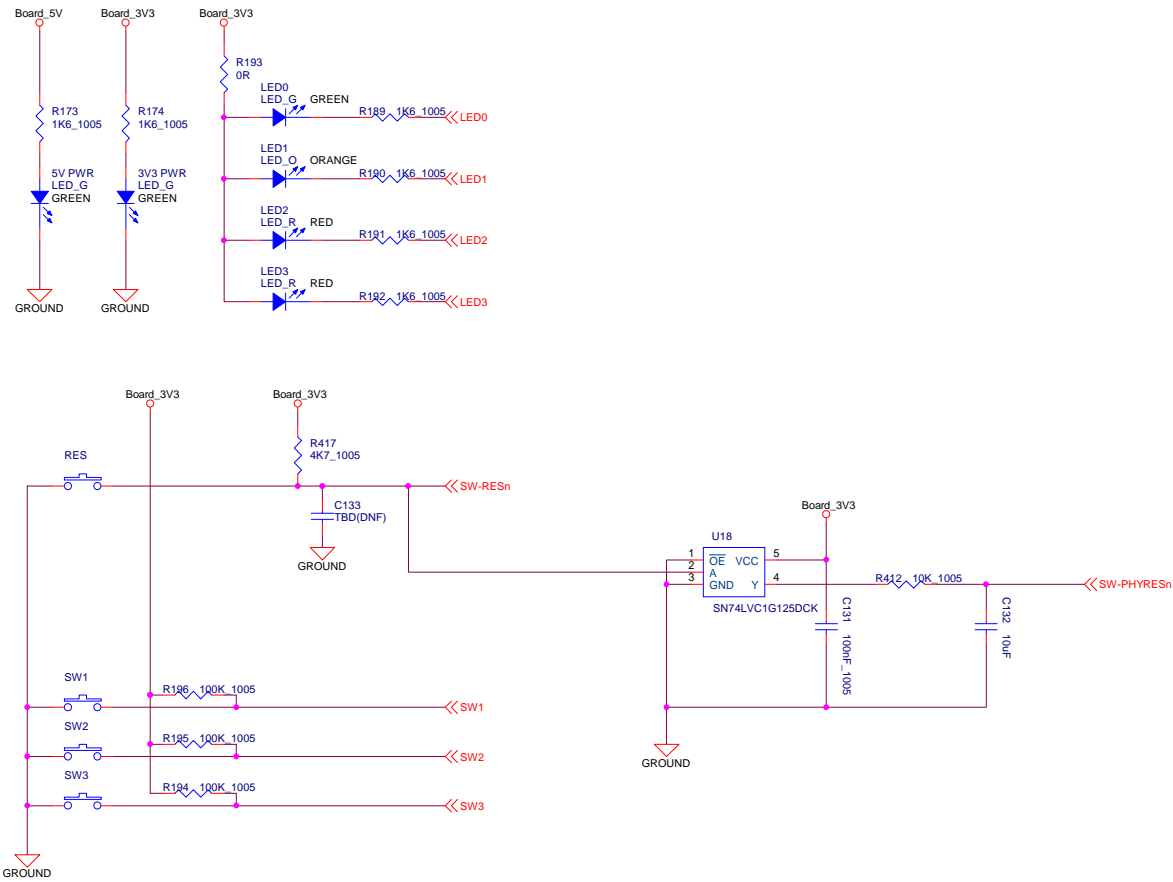

Renesas Electronics Corporation		
Title: RSK+RX72N [RESET, Switches, LEDs]		
Size: R20UT4435EG0100	Document Number: R20UT4435EG0100	Rev: 1.00
Date: Friday, November 29, 2019	Sheet: 9	of 22

USB to Serial Interface

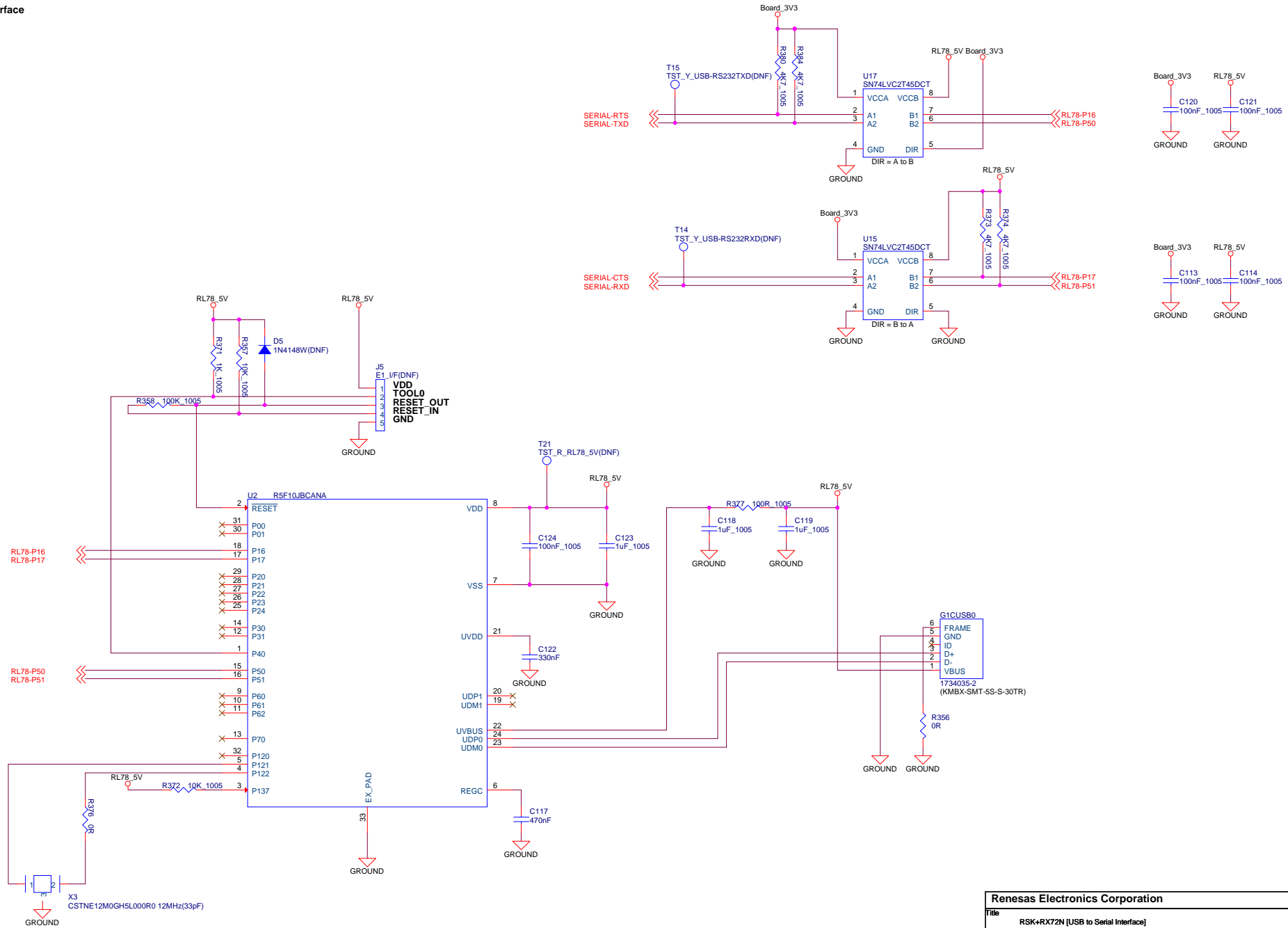

Renesas Electronics Corporation		
Title: RSK+RX72N [USB to Serial Interface]		
Size: R20UT4435EG0100	Document Number: R20UT4435EG0100	Rev: 1.00
Date: Friday, November 29, 2019	Sheet: 10	of 22

Pmod connectors

PMOD1: Angle type connector

PMOD2: Vertical type connector (spare)

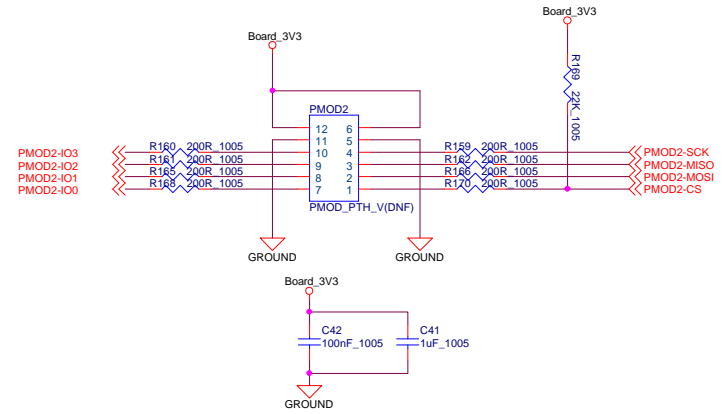
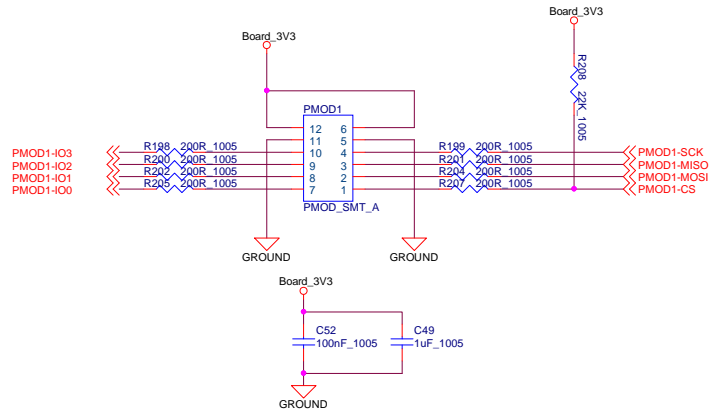

IIC EEPROM(2Kbits) - RIIC

Warning:

NEVER FIT R113 and R114 simultaneously.

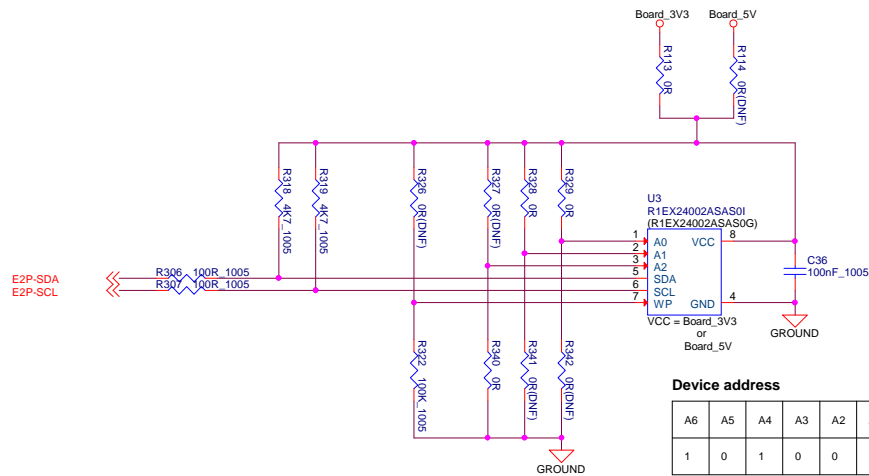

Device address

A6	A5	A4	A3	A2	A1	A0
1	0	1	0	0	1	1

Application Headers

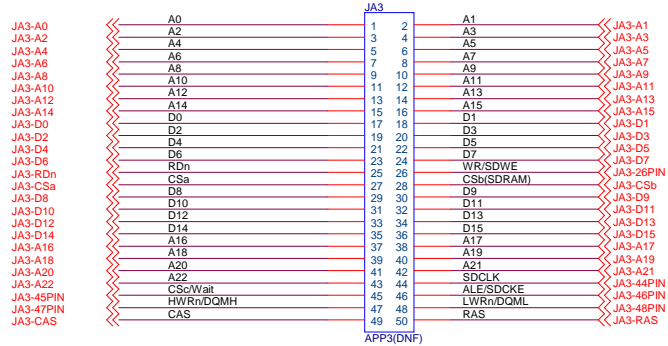
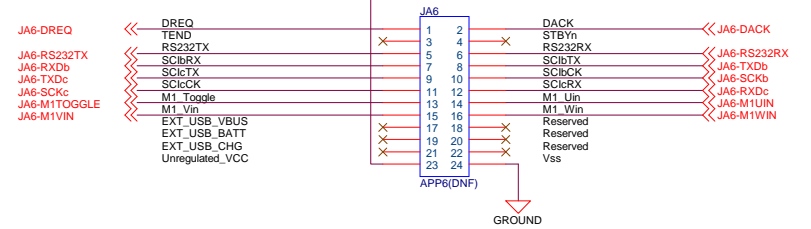
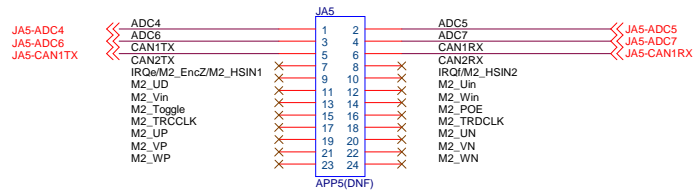
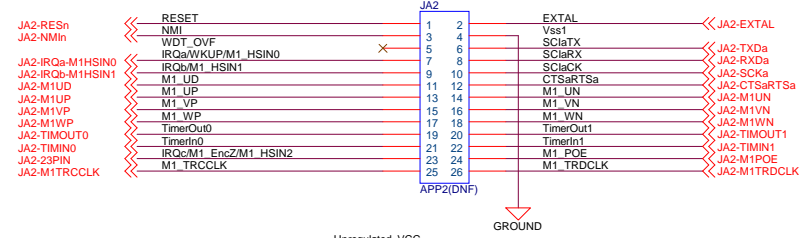
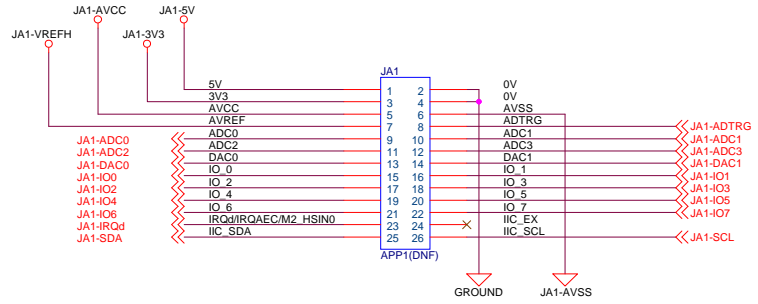

SDRAM(128Mbits)

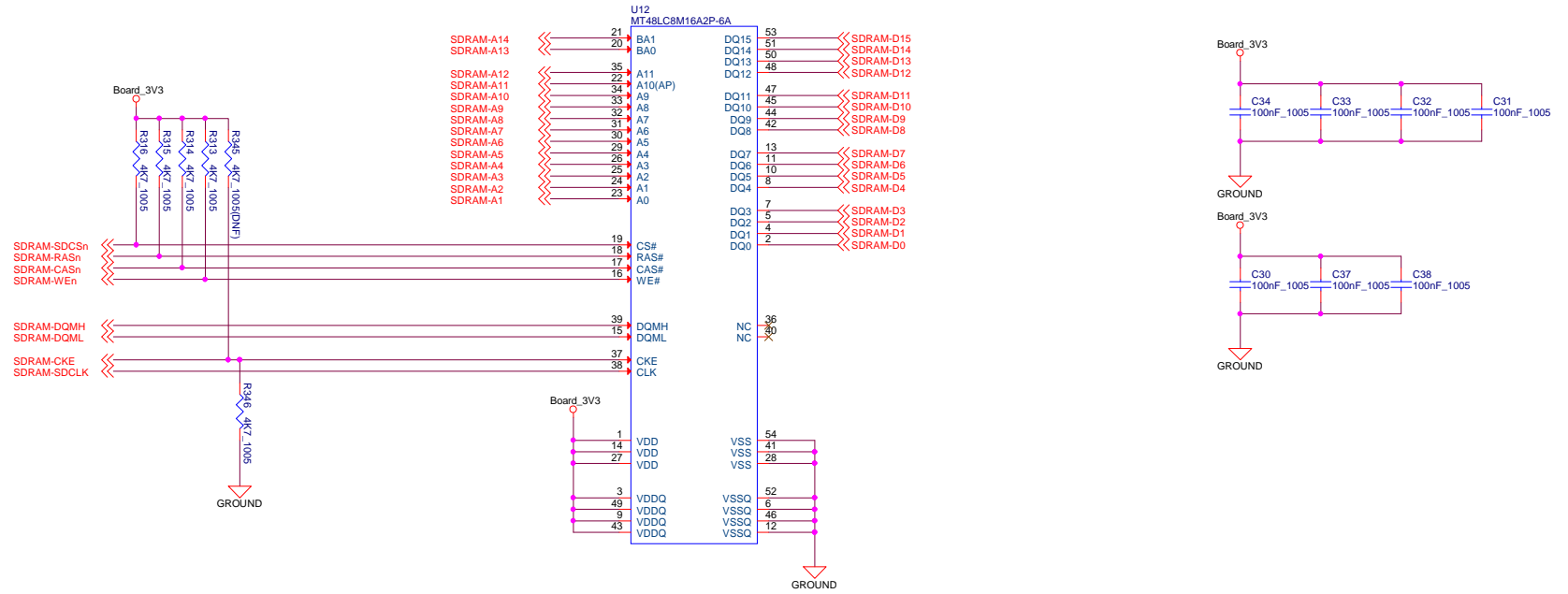

CAN

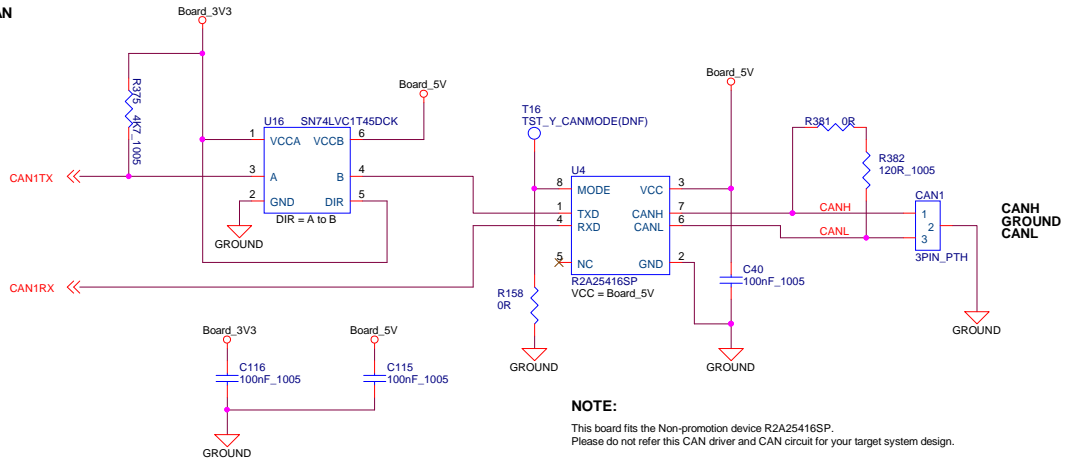

NOTE:
This board fits the Non-promotion device R2A25416SP.
Please do not refer this CAN driver and CAN circuit for your target system design.

RSPI- SPI Serial Flash(32Mbits)

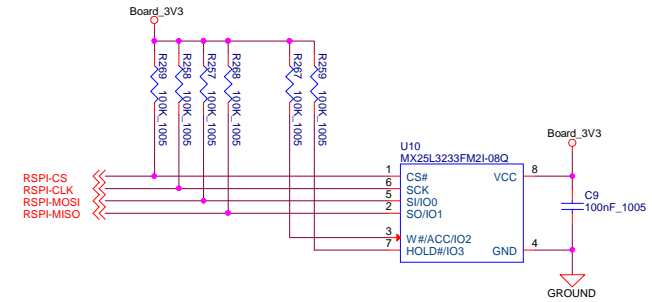

QSPI- SPI Serial Flash(32Mbits)

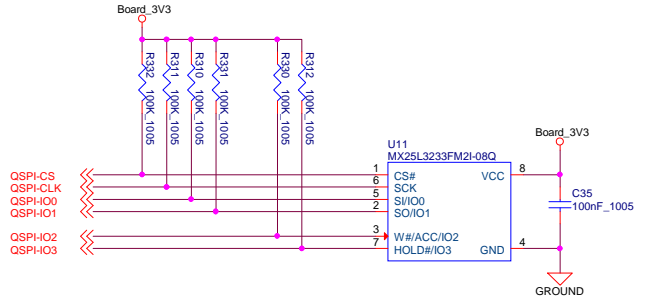

PDC

Warning:
When the voltage of your PDC target system differs from this board, please do not supply a board power to your system directly.
When the voltage of your PDC target system differs from this board, please do not fit resistor R418.
Please fix pull-up resistor on your PDC target system.

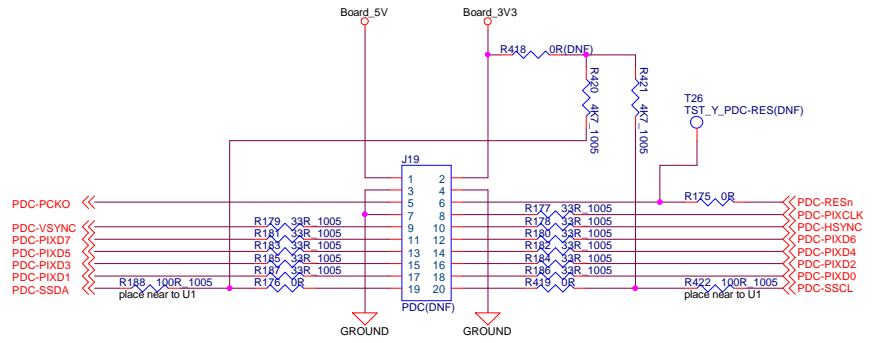

SSI

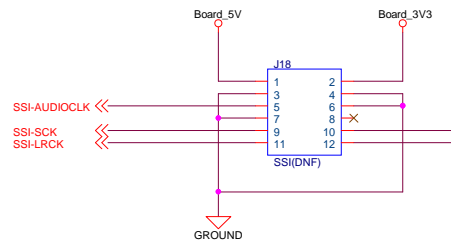

On-board TFT

Note:

On-board TFT circuit is the design based on NHD-4.3-480272EF-ATXL#-CTP (4.3" 480x272 with Capacitive Touch).

Display Interface

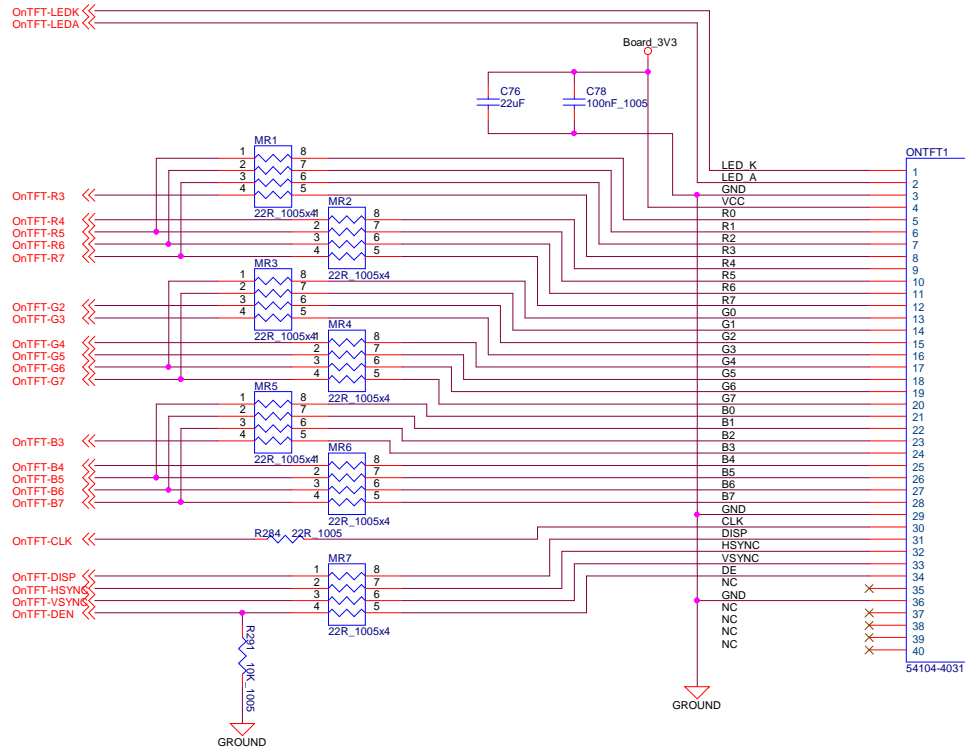

Capacitive Touch Interface

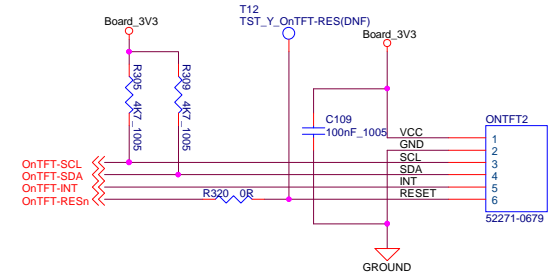

Device address for touch panel driver

A6	A5	A4	A3	A2	A1	A0
0	1	1	1	0	0	0

LED Backlight

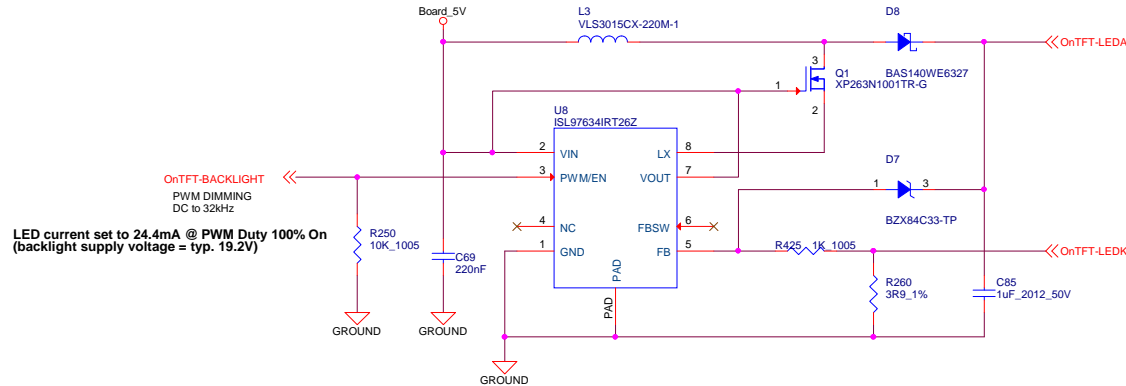

Renesas Electronics Corporation

Title		
RSK+RX72N [On-board TFT]		
Size	Document Number	Rev
	R20UT4435EG0100	1.00
Date:	Friday, November 29, 2019	Sheet 16 of 22

Ethernet (RJ45)

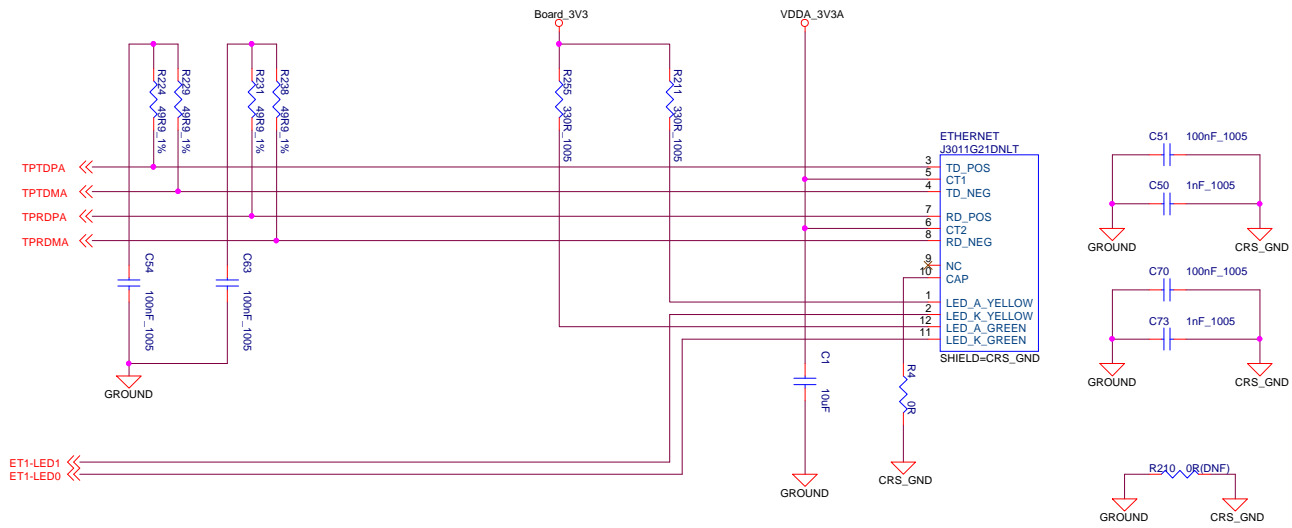

Unused-Pin

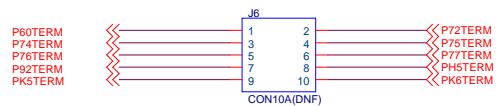

Renesas Electronics Corporation			
Title RSK+RX72N [Unused-Pin]			
Size	Document Number	Rev	
	R20UT4435EG0100	1.00	
Date:	Friday, November 29, 2019	Sheet	20 of 22

Revision History

REV	DATE	PAGE	DESCRIPTION
1.00	29.11.2019	---	1st release edition.

Renesas Electronics Corporation			
Title RSK+RX72N [Revision History]			
Size	Document Number R20UT4435EG0100	Rev	1.00
Date:	Friday, November 29, 2019	Sheet	X of X