

REV	REF	DATE	DRAWN BY
1.00	Release	01.10.2019	KOS

Renesas Starter Kit+ for RX72M CPU Board Schematics

SHEET	DESCRIPTION
1	INDEX
2	RX72M Microcontroller-1
3	RX72M Microcontroller-2
4	RX72M Microcontroller-3
5	MCU Pin Function Select-1
6	MCU Pin Function Select-2
7	PSU
8	E1/E2 Lite Emulator, MCU & Emulator Mode Setting
9	Reset, Switches, LEDs
10	USB to Serial Interface
11	Pmod Interface, IIC EEPROM
12	Application Headers
13	SDRAM
14	SDHI
15	CAN, RSPI, QSPI, IIC EEPROM(For EtherCAT), RS-485
16	EtherCAT-ID, EtherCAT-LEDs, DSMIF
17	USB (Host / Function)
18	Ethernet PHY(0)
19	Ethernet PHY(1)
20	Ethernet Connector

Note:

C : Capacitor
D : Diode
J : Connector, Jumper
L : Inductor
LED : Light Emitting Diode
MR : Resistor Array
PWR : Power Jack
R : Fixed Resistor
RES : Reset Switch
RV : Potentiometer
SW : Switch
T : Test Point
U : Integrated Circuit
X : Crystal, Oscillator

* "DNF" marking means that component is not fitted by default.

**The following off-page connectors used in this schematics do not indicate the signal direction.



Board Code:

RTK5572MNDC00000BE : RSK+RX72M MP Board

RTK5572MNH000000BE : RSK+RX72M MP Board (Encryption version)

Abbreviations:

CAN : Controller Area Network
IIC : Philips(TM) Inter-Integrated Circuit Connection Bus
LED : Light Emitting Diode
MCU : Microcontroller Unit
PSU : Power Supply Unit
RSK : Renesas Starter Kit
USB : Universal Serial Bus
SDHI : SD (Secure Digital) Host Interface
DSMIF : Delta Sigma Modulator Interface

REE Drawing No. D016462_04

Renesas Electronics Corporation		
Title RSK+RX72M [Index]		
Size	Document Number R20UT4390EG0100	Rev 1.00
Date:	Tuesday, October 01, 2019	Sheet 1 of 20

RX72M Microcontroller-1

Note:
Microcontroller's pins are not described by the full pin function.
For full pin functions details, refer to RX72M datasheet.

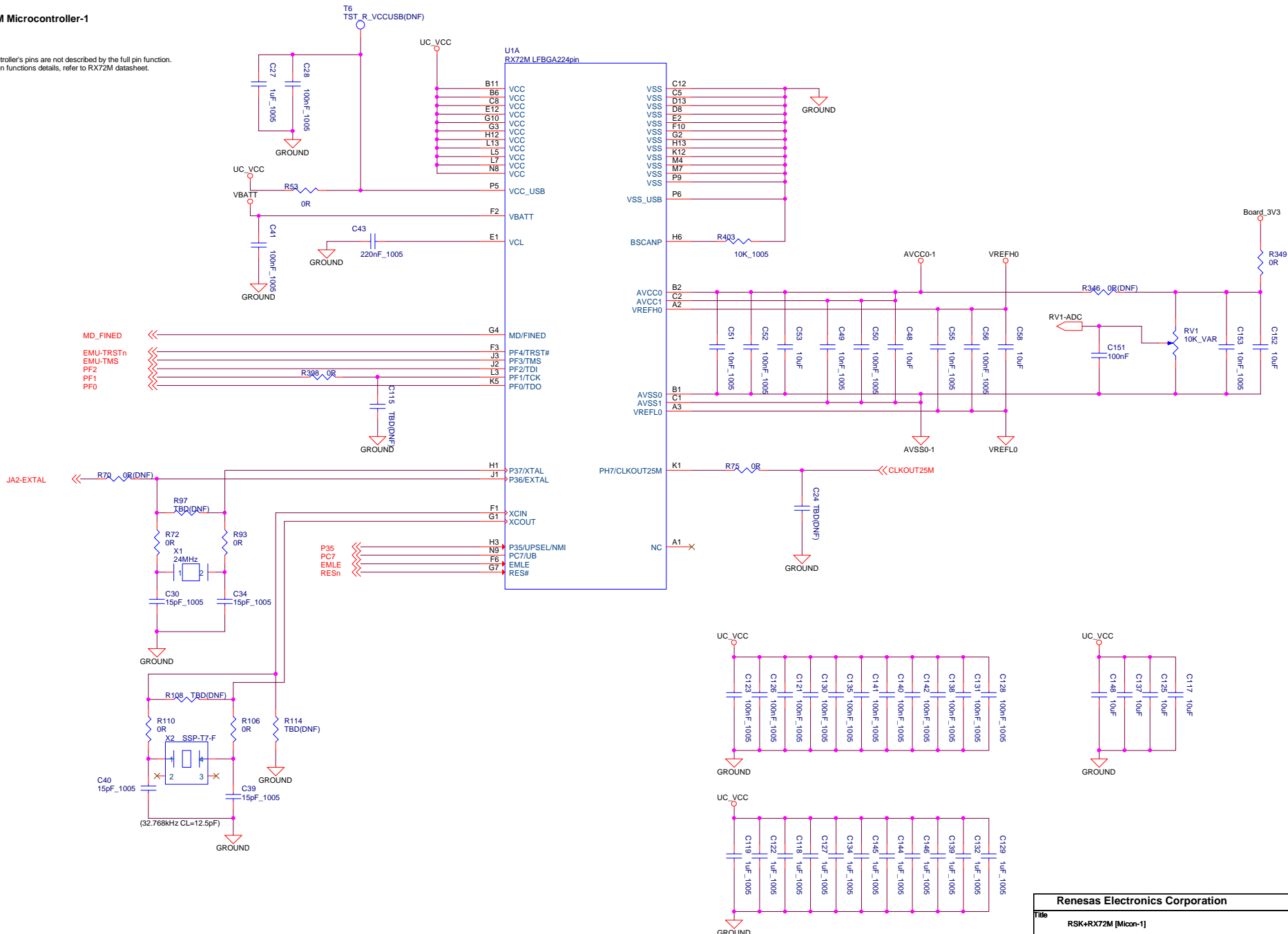

Renesas Electronics Corporation		
Title: RSK+RX72M [Micon-1]		
Size: R20UT4390EG0100	Document Number: R20UT4390EG0100	Rev: 1.00
Date: Tuesday, October 01, 2019	Sheet: 2	of 20

RX72M Microcontroller-2

Note:
 Microcontroller's pins are not described by the full pin function.
 For full pin functions details, refer to RX72M datasheet.

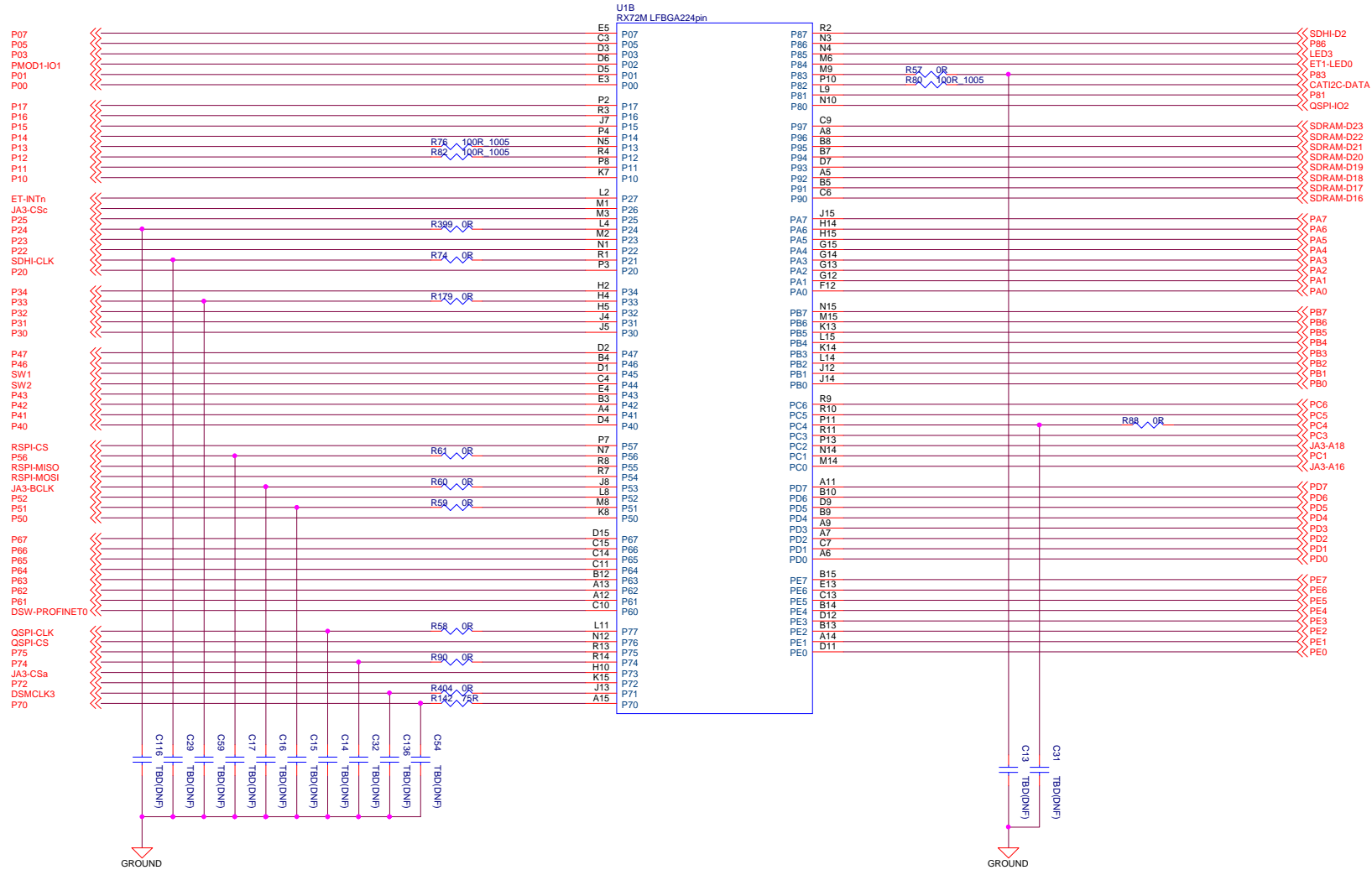

Renesas Electronics Corporation		
Title: RSK+RX72M [Micon-2]		
Size: R20UT4390EG0100	Document Number: R20UT4390EG0100	Rev: 1.00
Date: Tuesday, October 01, 2019	Sheet: 3	of 20

RX72M Microcontroller-3

Note:

Microcontroller's pins are not described by the full pin function.
For full pin functions details, refer to RX72M datasheet.

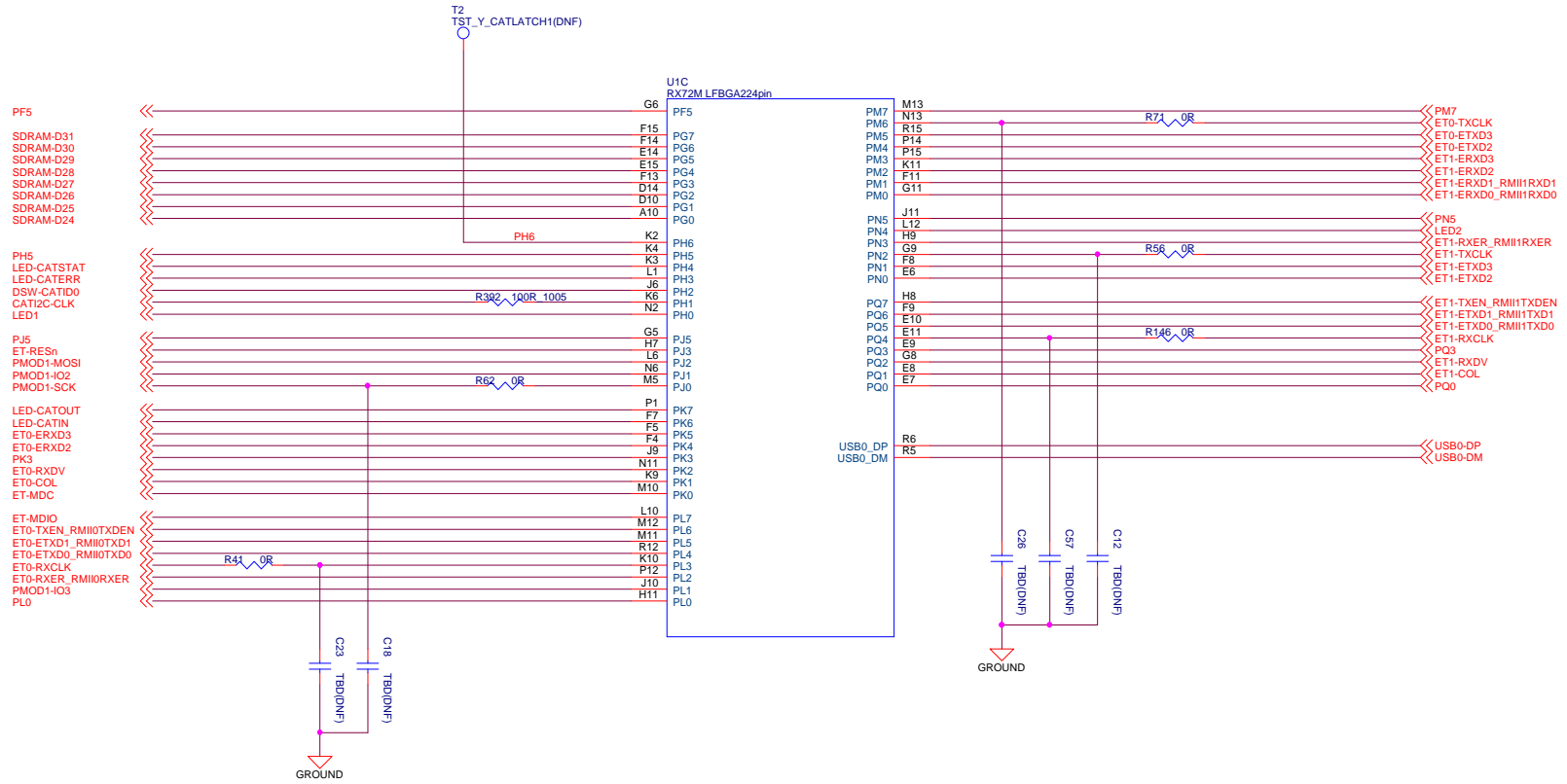

MCU Pin Function Select-1

AVCC0 (PinB2), AVCC1 (PinC2)

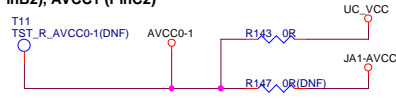

AVSS0 (PinB1), AVSS1 (PinC1)

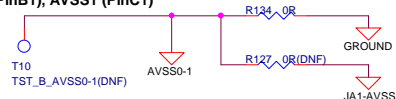

VREFH0 (PinA2)

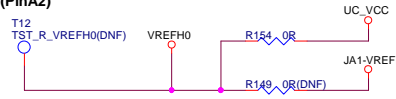

VREFL0 (PinA3)

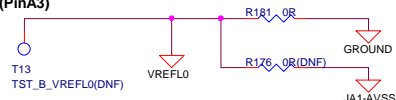

RES# (PinG7)



EMLE (PinF6)



MD_FINED (PinG4)



P07 (PinE5)

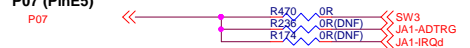

P05 (PinC3)

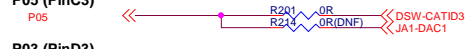

P03 (PinD3)



P01 (PinD5)



P00 (PinE3)

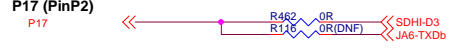

P17 (PinP2)

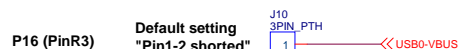

P16 (PinR3)



P15 (PinJ7)



P14 (PinP4)



P13 (PinN5)

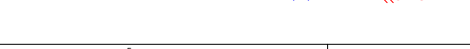

P12 (PinR4)



P11 (PinP8)

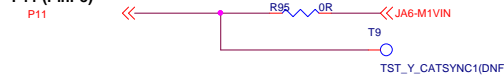

P10 (PinK7)

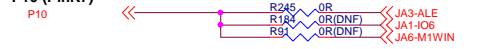

P25 (PinM3)



P24 (PinL4)



P23 (PinM2)

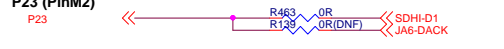

P22 (PinN1)



P20 (PinP3)



P35 (PinH3)



P34 (PinH2)

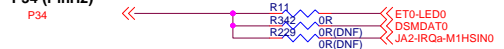

P33 (PinH4)



P32 (PinH5)



P31 (PinJ4)



P30 (PinJ5)

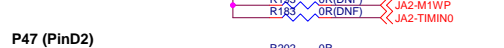

P47 (PinD2)



P46 (PinB4)

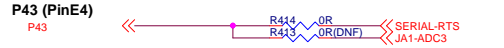

P43 (PinE4)

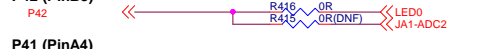

P42 (PinB3)

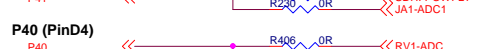

P41 (PinA4)



P40 (PinD4)

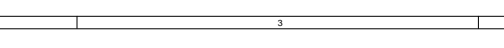

P56 (PinN7)



P52 (PinL8)



P51 (PinM8)



P50 (PinK8)



P67 (PinD15)



P66 (PinC15)



P65 (PinC14)



P64 (PinC11)



P63 (PinB12)



P62 (PinA13)



P61 (PinA12)



P75 (PinR13)

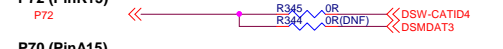

P74 (PinR14)



P72 (PinK15)



P70 (PinA15)



P86 (PinN3)



P83 (PinM9)

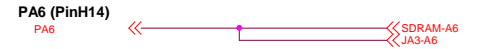

P81 (PinL9)

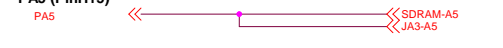

PA7 (PinJ15)



PA6 (PinH14)



PA5 (PinH15)

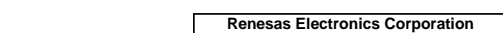

Renesas Electronics Corporation		
Title RSK+RX72M [MCU Pin Function Select-1]		
Size	Document Number R20UT4390EG0100	Rev 1.00
Date:	Tuesday, October 01, 2019	Sheet 5 of 20

MCU Pin Function Select-2

PA4 (PinG15)



PA3 (PinG14)



PA2 (PinG13)



PA1 (PinG12)



PA0 (PinF12)



PB7 (PinN15)



PB6 (PinM15)



PB5 (PinK13)



PB4 (PinL15)



PB3 (PinK14)



PB2 (PinL14)



PB1 (PinJ12)



PB0 (PinJ14)



PC7 (PinN9)

Default setting
"Pin1-2 shorted"

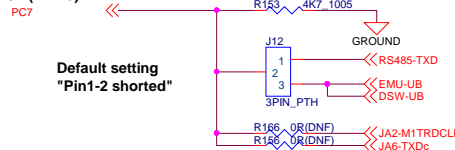

PC6 (PinR9)



PC5 (PinR10)



PC4 (PinP11)



PC3 (PinR11)



PC1 (PinN14)



PD7 (PinA11)



PD6 (PinB10)



PD5 (PinD9)



PD4 (PinB9)



PD3 (PinA9)



PD2 (PinA7)



PD1 (PinC7)



PD0 (PinA6)



PE7 (PinB15)



PE6 (PinE13)



PE5 (PinC13)



PE4 (PinB14)



PE3 (PinD12)

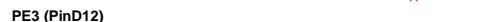

PE2 (PinB13)



PE1 (PinA14)



PE0 (PinD11)



PF5 (PinG6)



PF2 (PinJ2)



PF1 (PinL3)



PF0 (PinK5)



PH5 (PinK4)



PJ5 (PinG5)



PK3 (PinJ9)



PL0 (PinH11)



PN5 (PinJ11)



PQ3 (PinE9)



PM7 (PinM13)



PK2 (PinN11)



PQ0 (PinE7)



PQ2 (PinG8)

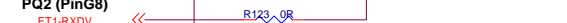

Application Header Function Select



E1/E2 Lite Emulator Interface

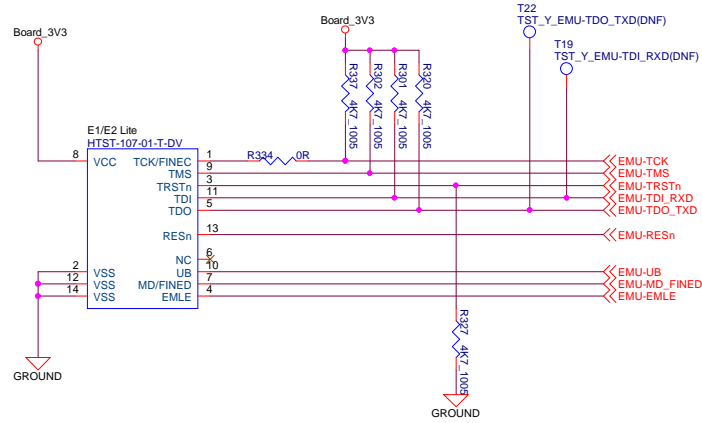

Option pull-up resistor

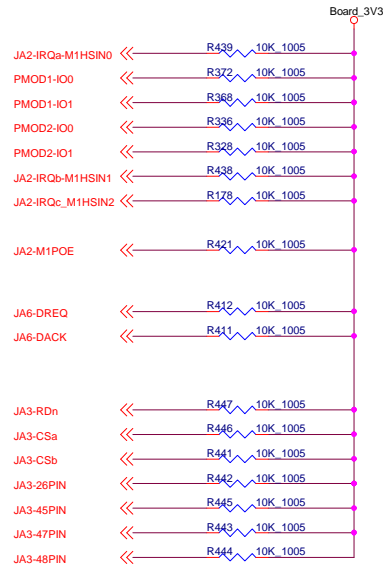

MCU & Emulator Mode Setting

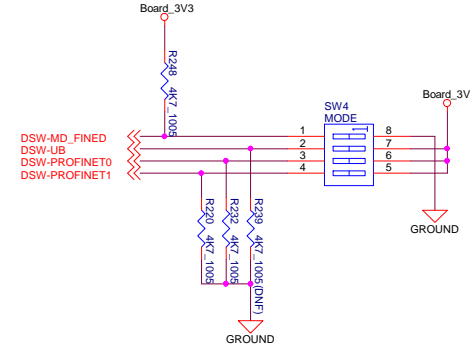

MCU Operating Mode Configuration

SW4 Pin1	SW4 Pin2	J14	Operating Mode
OFF	Don't care	Don't care	Single Chip Mode
ON	OFF	Don't care	SCI Boot Mode
ON	ON	Open	USB Boot Mode (Bus Powered)
ON	ON	Shorted Pin	USB Boot Mode (Self Powered)

Default setting of SW4.

SW4	Default
Pin1	OFF
Pin2	OFF
Pin3	OFF
Pin4	OFF

Emulator Configuration

J17	Emulator Configuration
Shorted Pin1-2	E1/E2 Lite normal debugging
	Microcontroller single operation (without emulator)
Shorted Pin2-3	E1/E2 Lite debugging with Hot plug-in
All open	DO NOT SET

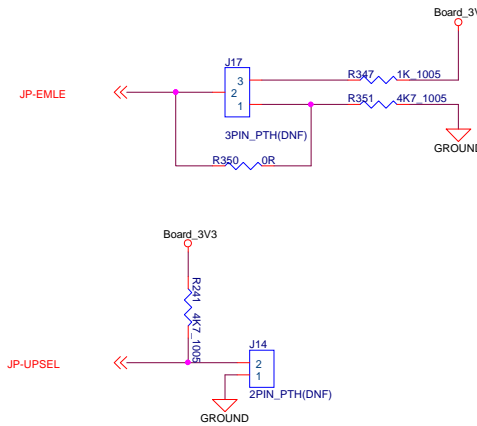

Power Configuration for USB Boot Mode

J14	Power Configuration
Open	Bus Powered
Shorted	Self Powered

Renesas Electronics Corporation

Title		
RSK+RX72M [E1/E2 Lite, MCU & Emulator Mode Setting, Pull-up resistors]		
Size	Document Number	Rev
	R20UT4390EG0100	1.00
Date:	Tuesday, October 01, 2019	Sheet 8 of 20

Switches, LEDs, RESET

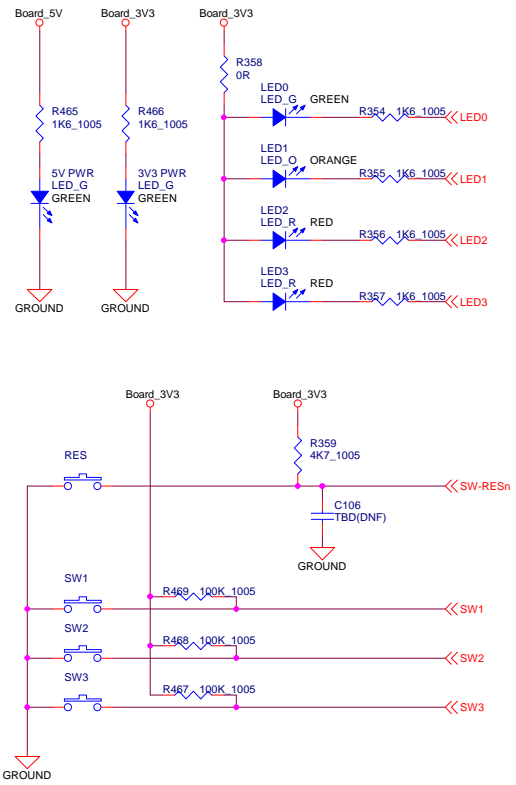

USB to Serial Interface

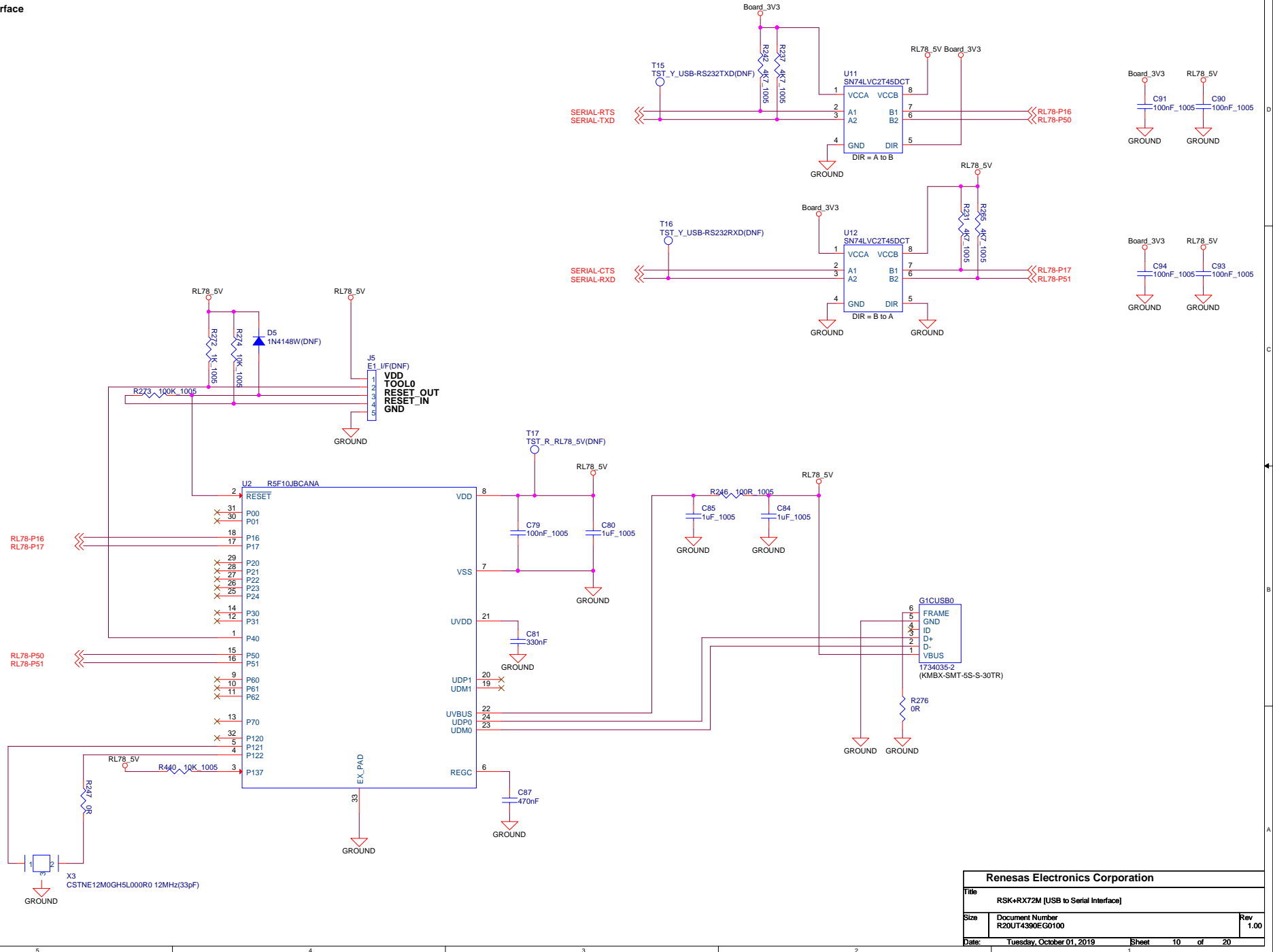

Renesas Electronics Corporation		
Title: RSK+RX72M [USB to Serial Interface]		
Size: R20UT4390EG0100	Document Number: R20UT4390EG0100	Rev: 1.00
Date: Tuesday, October 01, 2019	Sheet: 10	of 20

Pmod connectors

PMOD1: Angle type connector

PMOD2: Vertical type connector (spare)

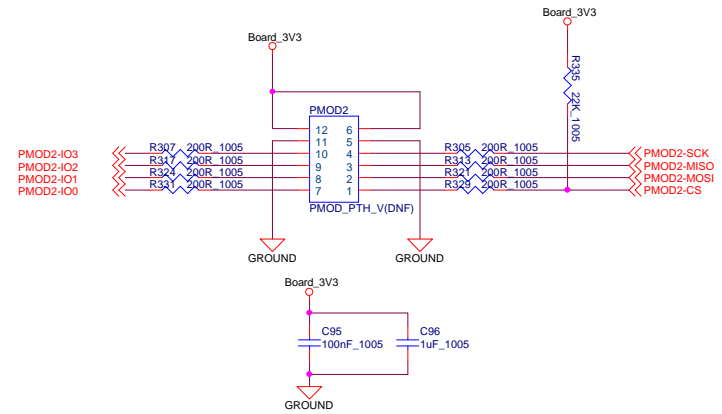
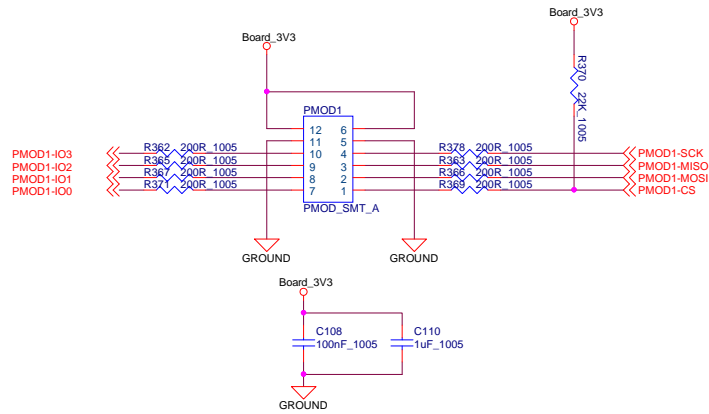

IIC EEPROM(2Kbits) - RIIC

Warning:

NEVER FIT R271 and R270 simultaneously.

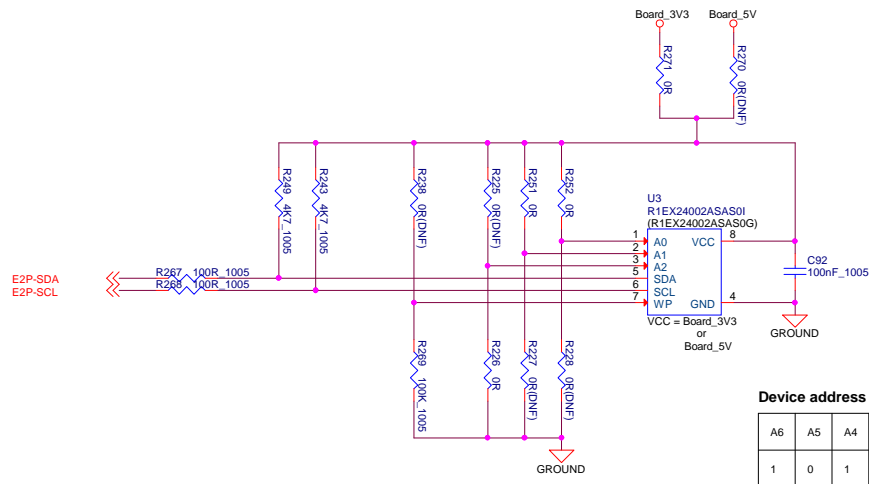

Device address

A6	A5	A4	A3	A2	A1	A0
1	0	1	0	0	1	1

Application Headers

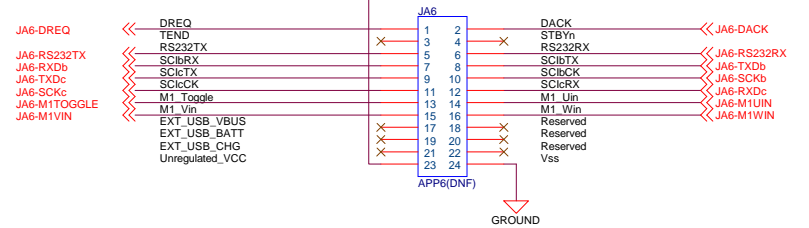
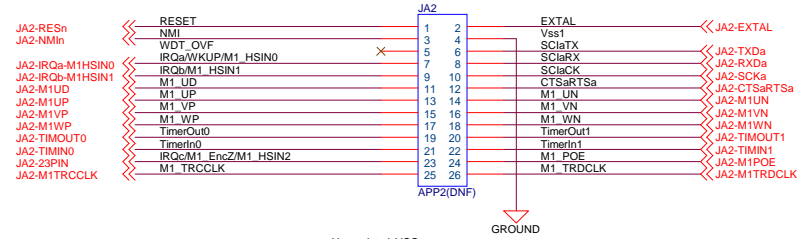
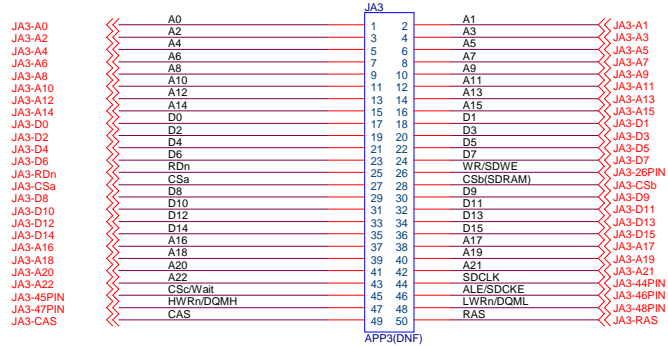
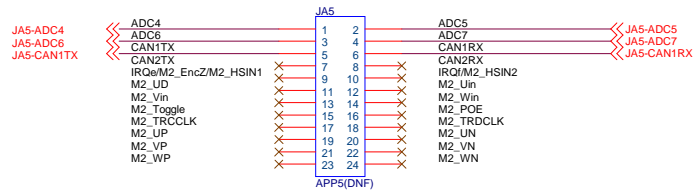
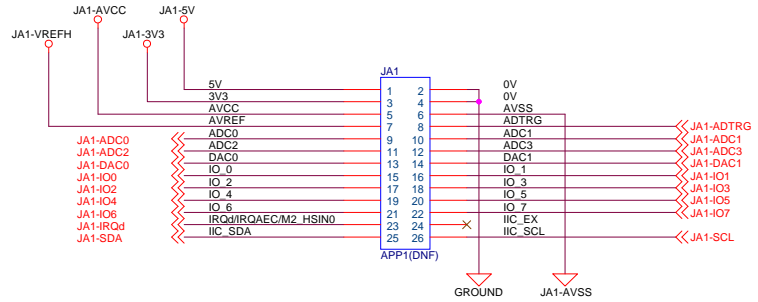

SDRAM(128Mbits)

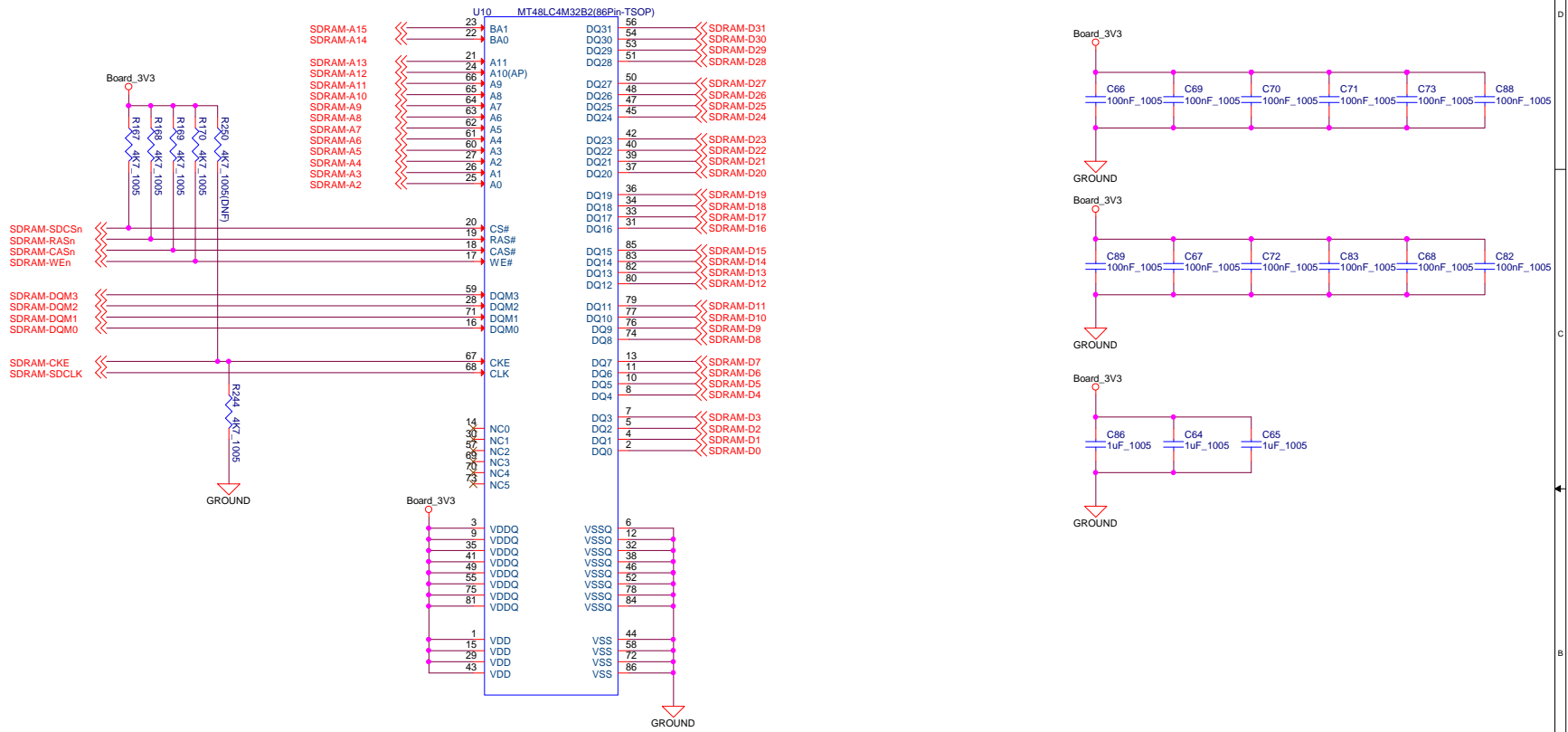

SDHI

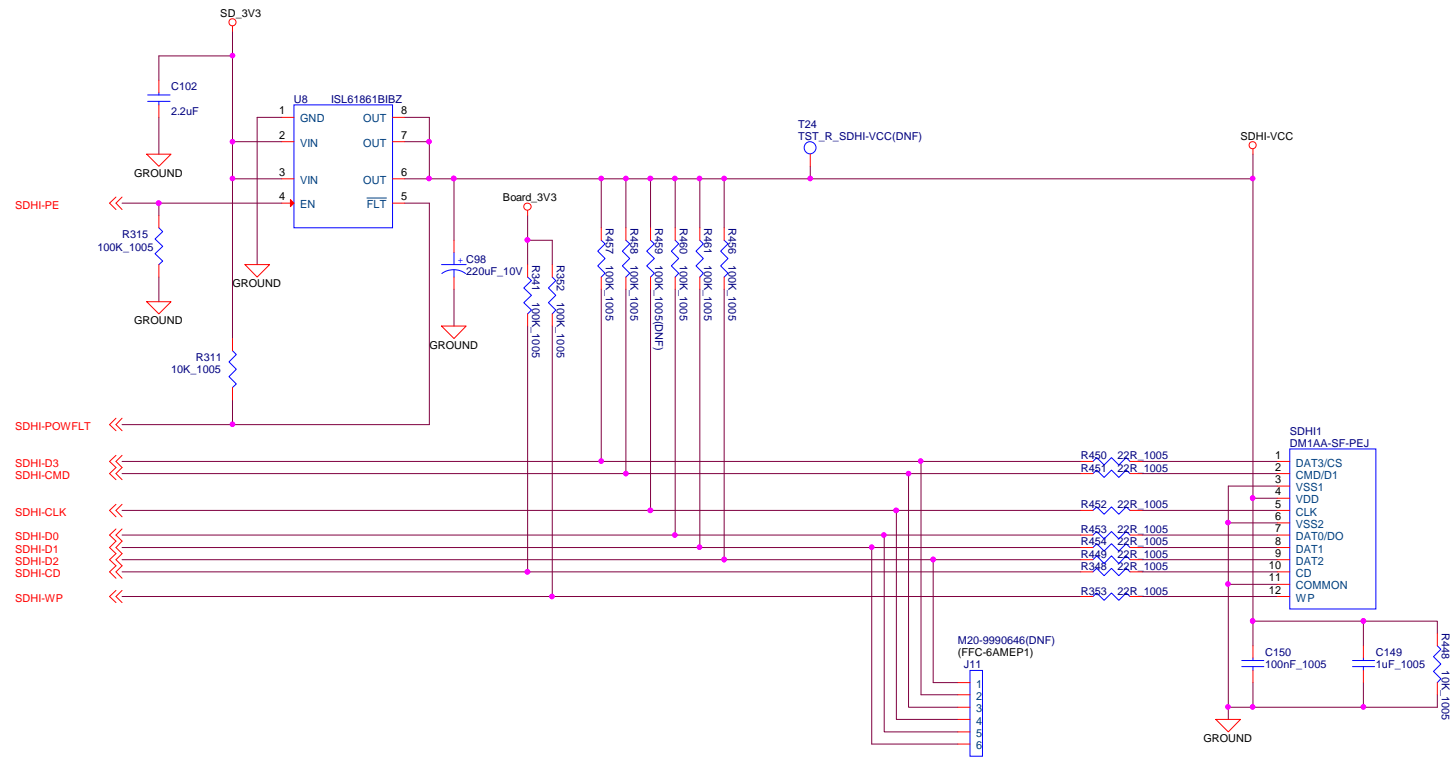

CAN

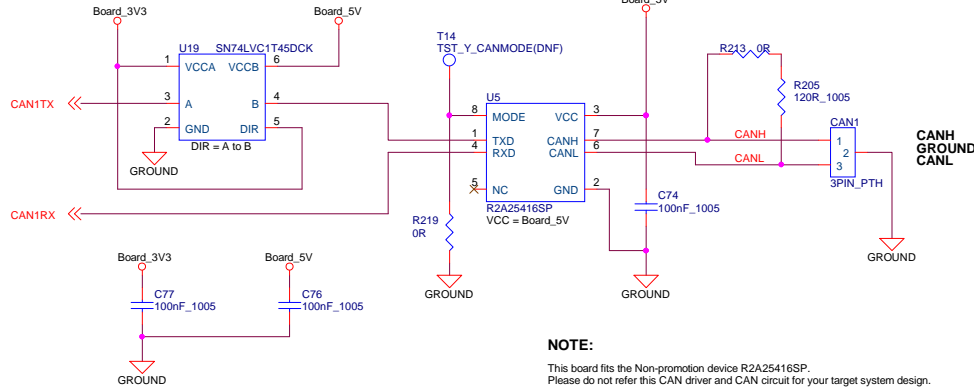

NOTE:
This board fits the Non-promotion device R2A25416SP.
Please do not refer this CAN driver and CAN circuit for your target system design.

RSPI- SPI Serial Flash(32Mbits)

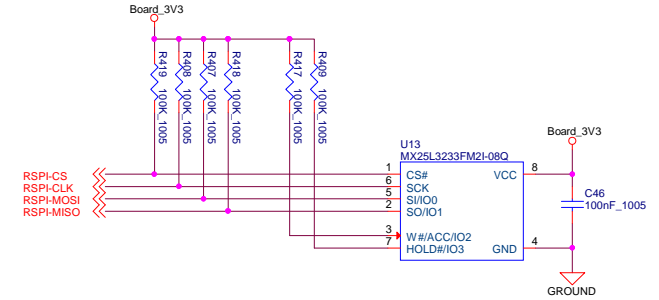

Serial EEPROM For EtherCAT(16Kbits)

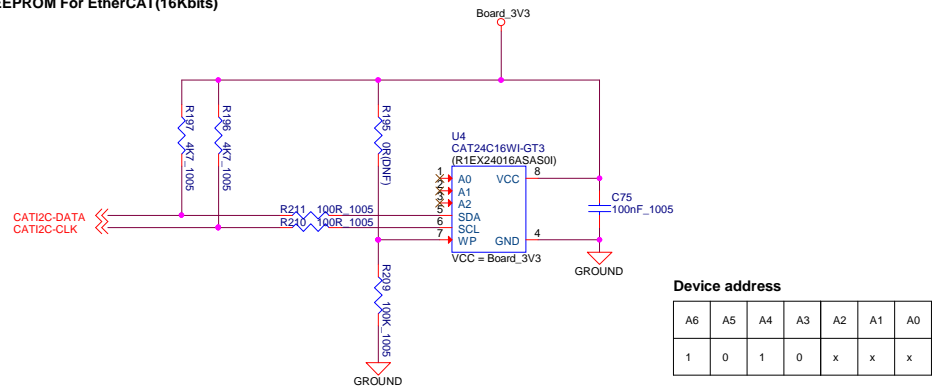

Device address

A6	A5	A4	A3	A2	A1	A0
1	0	1	0	x	x	x

QSPI- SPI Serial Flash(32Mbits)

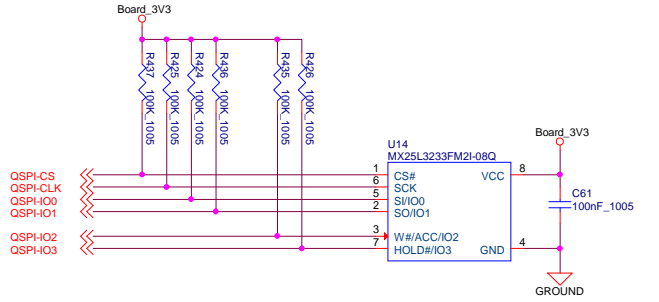

RS-485

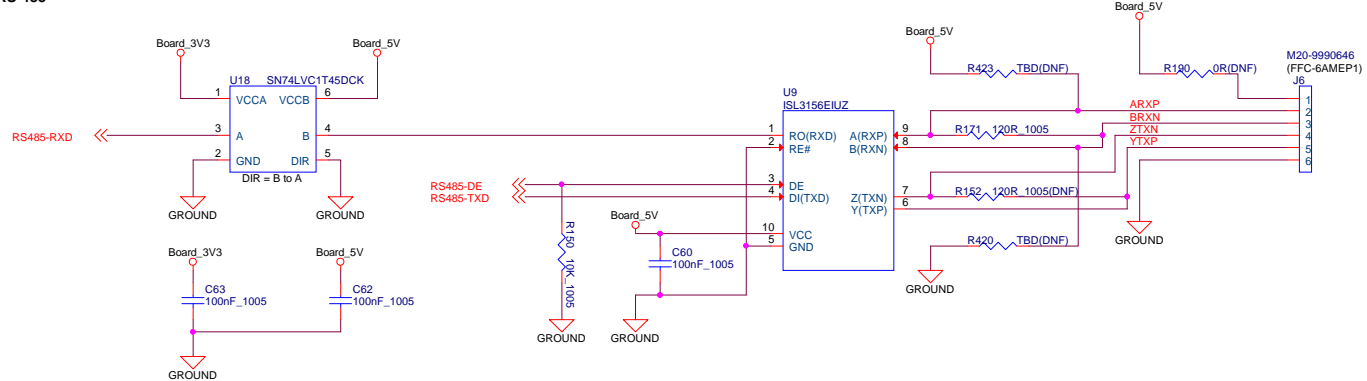

EtherCAT-LEDs, EtherCAT-ID

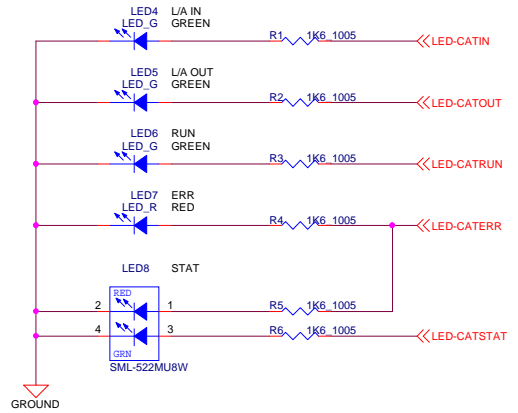

**Default setting
"All OFF"**

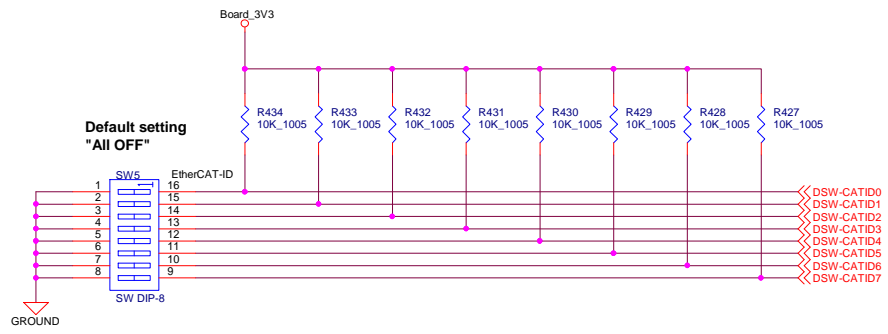

DSMIF

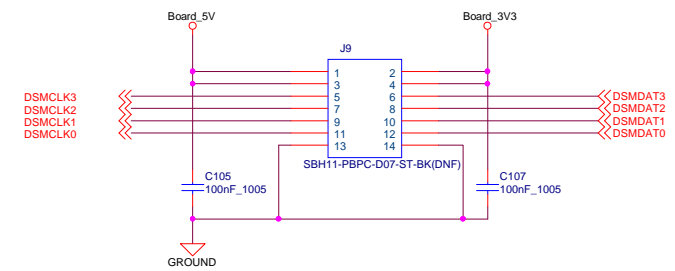

USB0 Host/Function

USB0 Host/Function Select

J8	Function Mode
1-2 shorted	Function Mode
2-3 shorted	Host Mode

Self-powered/Bus-powered Function Mode Configuration

J7	R26	Self-powered
1-2 shorted	Remove	Self-powered
2-3 shorted	Remove	Bus-powered
Open	Fit	Self-powered

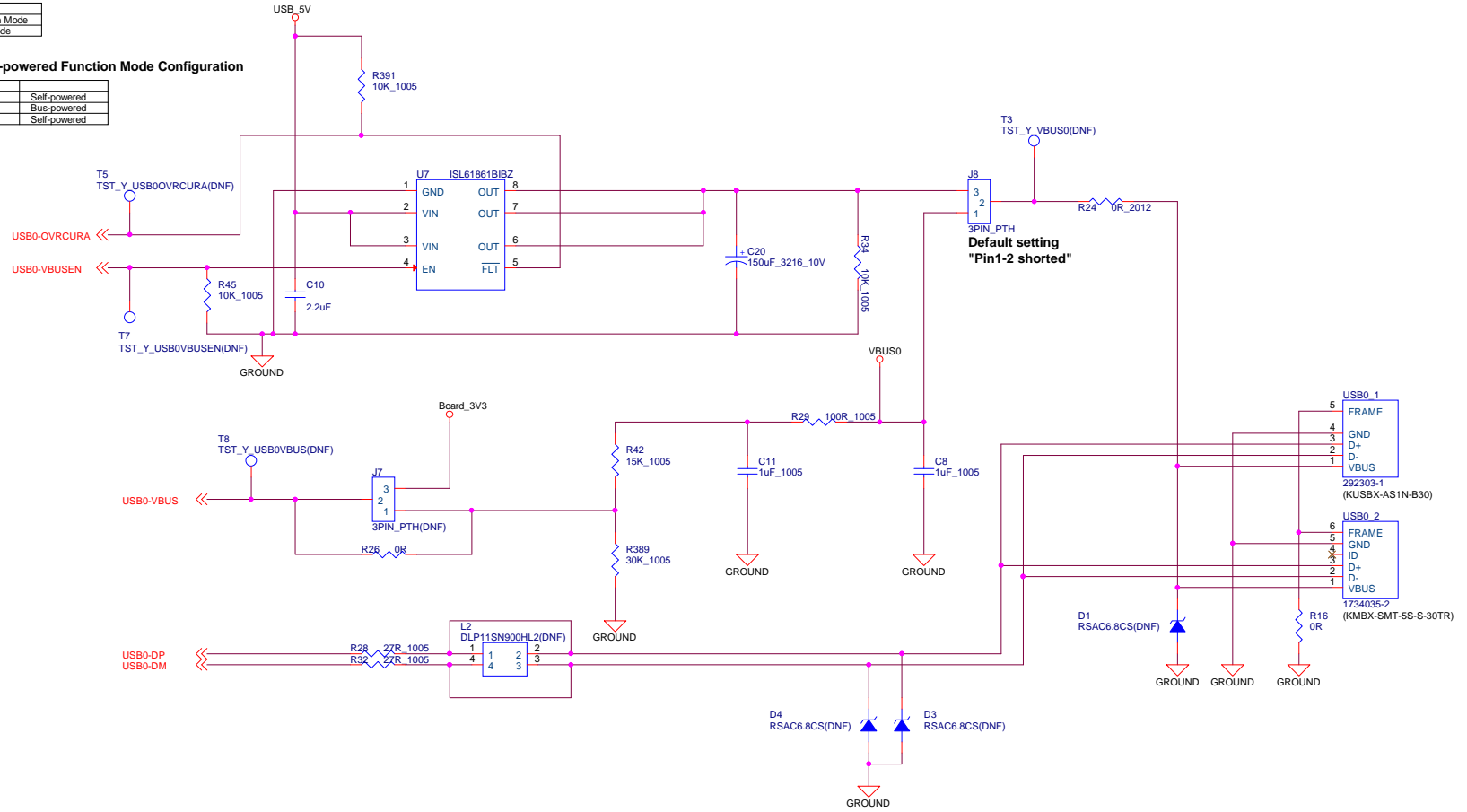

Ethernet (PHY0)

```

PHYAD[2-0]=001
CONFIG[2-0]=000 -> MII(Default), 001 -> RMI
ISOLATE=0 -> Disable
SPEED=1 -> 100Mbps
DUPLEX=0 -> Full Duplex
NMAY=1 -> Auto-nego Enable
    
```

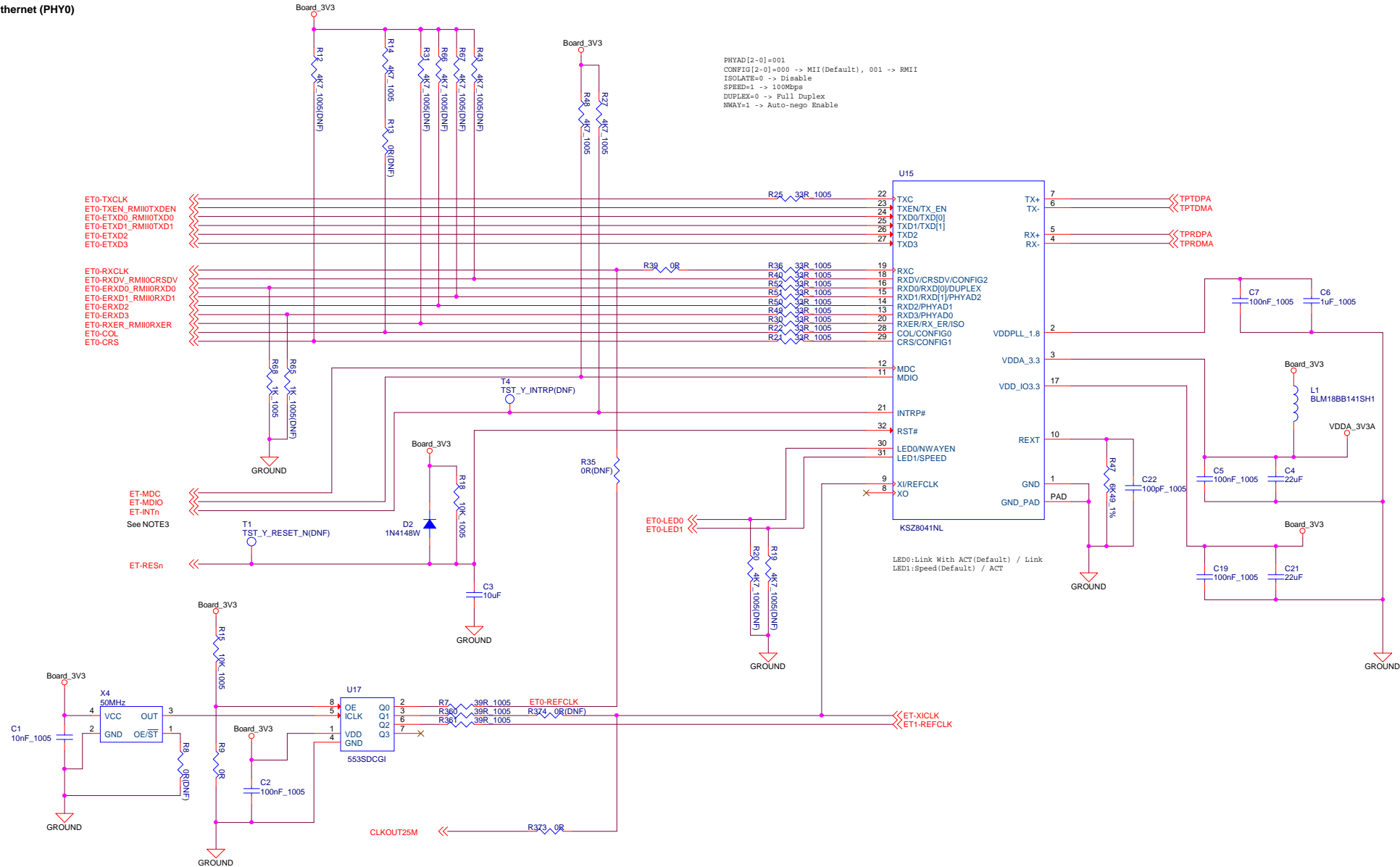

ET0-TXCLK
ET0-TXEN_RMI0TXDEN
ET0-ETXD0_RMI0TXD0
ET0-ETXD1_RMI0TXD1
ET0-ETXD2
ET0-ETXD3

ET0-RXCLK
ET0-RXDV_RMI0CRSDV
ET0-ERXD0_RMI0RXD0
ET0-ERXD1_RMI0RXD1
ET0-ERXD2
ET0-ERXD3
ET0-RXER_RMI0RXER
ET0-COL
ET0-CRS

ET-MDC
ET-MDIO
ET-INTR#
See NOTE3

ET-RESn

ET0-LED0
ET0-LED1

LED0:Link With ACT(Default) / Link
LED1:Speed(Default) / ACT

PHY Mode	R35, R374, R103, R13, R78, R46, R115	R9, R39, R373, R109, R55, R377, R123, R401
MII (Default)	DNF	Fit
RMI	Fit	DNF

NOTE1: R103, R109, R78 Refers to page 19.
NOTE2: R46, R55, R377, R115, R123, R401 Refers to page 6.

NOTE3
The PHY interrupt is connected to IRQ1 and CATIRO.
IRQ1 and CATIRO can't be locked exclusively by hardware.
Therefore only enable one of the interrupts.

Renesas Electronics Corporation		
Title: RSK+RX72M [Ethernet PHY(0)]		
Size	Document Number: R20UT4390EG0100	Rev: 1.00
Date:	Tuesday, October 01, 2019	Sheet: 18 of 20

Ethernet (RJ45)

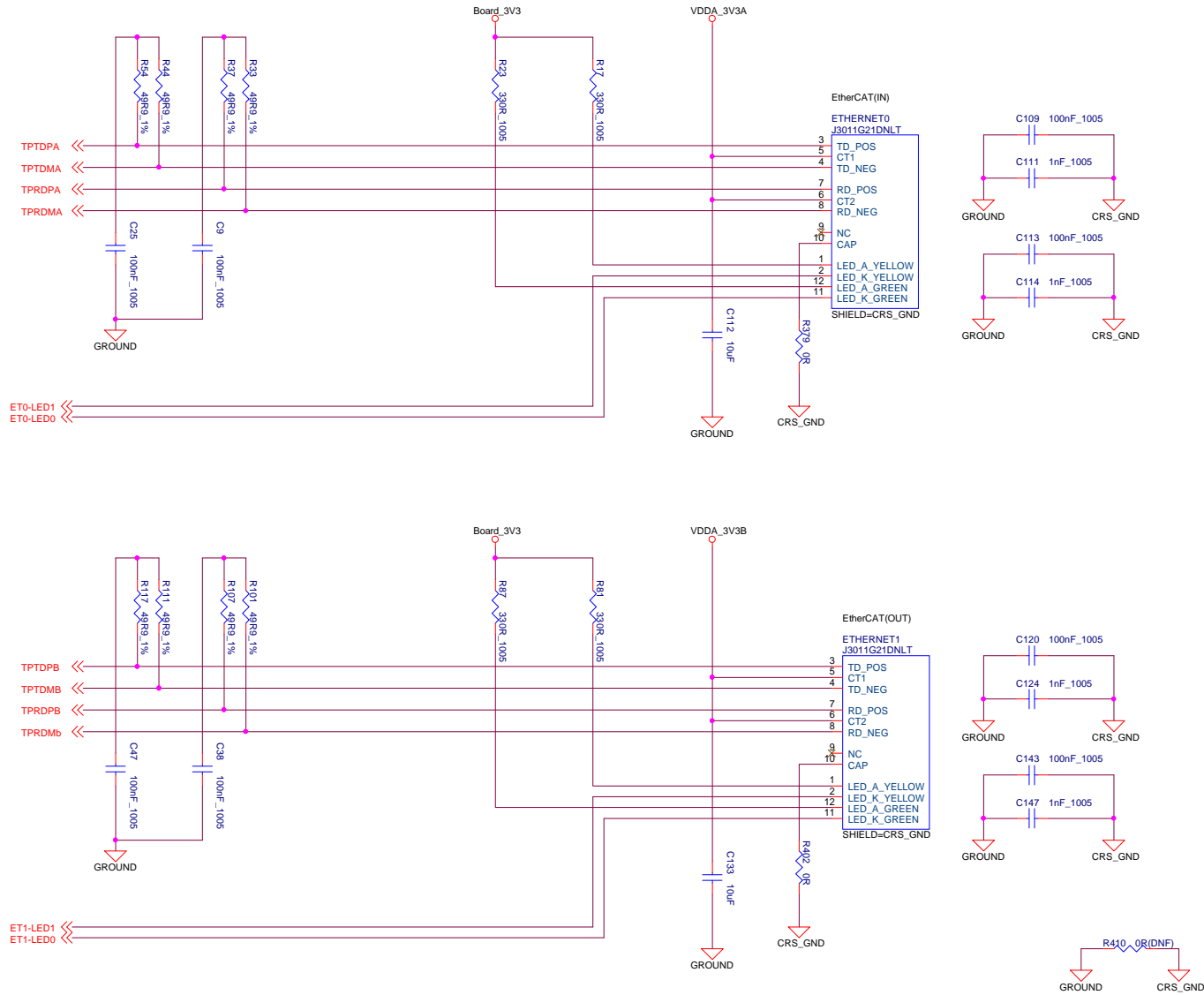

Renesas Electronics Corporation		
Title: RSK+RX72M [Ethernet RJ45]		
Size: R20UT4390EG0100	Document Number: R20UT4390EG0100	Rev: 1.00
Date: Tuesday, October 01, 2019	Sheet: 20	of 20

Revision History

REV	DATE	PAGE	DESCRIPTION
1.00	01.10.2019	---	1st release edition.

Renesas Electronics Corporation			
Title RSK+RX72M [Revision History]			
Size	Document Number	Rev	
	R20UT4390EG0100	1.00	
Date:	Tuesday, October 01, 2019	Sheet	X of X