

ISL73007MEVAL1Z

Radiation Tolerant ISL73007M Buck Regulator Board

Description

The ISL73007MEVAL1Z evaluation board and this accompanying manual provide a quick and easy method to evaluate the [ISL73007M](#) buck regulator. The device is a small foot print, radiation tolerant point-of-load (POL) synchronous buck converter designed for critical low-power applications.

The ISL73007M is operational over an input voltage range of 3V to 18V and provides up to 3A of output current. The device features integrated high-side and low-side MOSFETs, undervoltage, overvoltage, overcurrent, and over-temperature protections, power-good, and soft-start. The device also supports a switching frequency range of 300kHz to 1MHz, which can be resistor programmable or synchronized to an external clock. The ISL73007M can be configured for internal compensation optimized for 500kHz default switching frequency or with external Type II compensation network as determined by specific design and performance requirements. The high level of integration allows for minimal external components, reducing the BOM count and complexity of the design.

See the *ISL73007M Datasheet* for information about the operation and performance of the device.

Features

- Optimized for 12V to 3.3V conversion and 500kHz switching frequency
- 3A output current
- SYNC input for optional external clock synchronization
- Jumper configurable internal or external compensation, switching frequency, and slope compensation
- Compact solution size

Specifications

The ISL73007MEVAL1Z evaluation board is configurable by jumpers for either external or internal configuration of loop compensation, switching frequency, and slope compensation. The board is designed for the operating conditions shown in [Table 1](#). For evaluation of other conditions user-modification of components and connections is required as described in [Table 5](#).

[Table 1](#) shows the electrical ratings of the ISL73007MEVAL1Z evaluation board.

Table 1. Board Specifications

Parameter	Rating
PVIN Supply Voltage	10.8V - 18V
DC Output Voltage	3.3V
Operating Frequency	500kHz
Output Current	3A
Temperature	-55°C to +125°C
PCB Layers / Thickness	4 layers, 2 oz. copper

Contents

1. Functional Description	3
1.1 Operational Characteristics	3
1.2 Setup and Configuration	3
1.3 On-Board Load Transient Generator	6
2. Board Design	7
2.1 Basic Layout	8
2.2 Layout Guidelines	8
2.3 Component Selection	8
2.4 Schematic Diagrams	9
2.5 Bill of Materials	9
2.6 Board Layout	11
3. Typical Performance Graphs	12
4. Ordering Information	14
5. Revision History	14

1. Functional Description

The ISL73007MEVAL1Z evaluation board is configured for 12V to 3.3V conversion with a 3A maximum output current using the ISL73007M voltage regulator. Configuration for switching frequency, loop compensation, and slope compensation can be selected using headers J2, J4, and J5, respectively. Synchronization to an external clock can be implemented through connection to the SYNC header, J3. Board photos of the ISL73007MEVAL1Z are shown in [Figure 2](#) and [Figure 3](#).

The ISL73007MEVAL1Z evaluation board provides test point access to critical pins of the IC for connecting test equipment. For more information, see the schematic ([Figure 4](#) and [Figure 5](#)), PCB layers ([Figure 6](#) through [Figure 11](#)), and [Bill of Materials](#). Performance data taken using the ISL73007MEVAL1Z is shown in [Figure 12](#) through [Figure 21](#).

1.1 Operational Characteristics

The ISL73007MEVAL1Z requires a single voltage supply between 10.8V to 18V connected to the PVIN terminal. Output voltage is 3.3V with a 3A output current capability. Configured for a nominal PVIN voltage of 12V, the input operating voltage at which the IC turns on is set by the resistor divider (R3 and R5) on the ENABLE pin. *Note:* Do not exceed 5V on the ENABLE pin.

1.2 Setup and Configuration

The following equipment is recommended for testing the board:

- 12V power supply
- 100MHz oscilloscope

Complete the following steps to configure and use the board:

1. Ensure configuration headers J2, J4, and J5 are populated with appropriate jumper connections for either internal or external configuration before providing power to the board. SLOPE, FS, and COMP must not be left floating for proper functionality.
2. Connect the 12V DC power supply to the PVIN input terminals.
3. If using an external load, connect it to the VOUT output terminals.
4. After powering on the input supply, LED D2 lights green when PG is active, indicating the supply is regulating.
5. Use test point headers on VOUT and LX for oscilloscope probe points. Proper probe grounding must be practiced to observe clean waveforms.

Table 2 describes the header configurations.

Table 2. Header Configuration Description

Name	Designator	Description
LOAD	J1	On board load transient generator enable. Needed when 12V input is applied to load transient driver supply, pins TP16 (12V) and TP17 (GND). Connect pins 1-2 to enable the load. Connect pins 2-3 to disable the load.
FS	J2	Connect pins 1-2 for internal switching frequency configuration of 500kHz. Tie FS to VCC. Connect pins 2-3 for external switching frequency configuration. Connect resistor R7 between the FS pin and GND to set frequency.
SYNC	J3	Apply external clock signal to pin 1 to synchronize device switching frequency. Ensure clock frequency is 15% greater than resistor programmed frequency on FS. Leave open if SYNC function is unnecessary.
COMP	J4	Connect pins 1-2 for internal compensation configuration. Tie COMP to VCC. Connect pins 2-3 for external compensation configuration. Connect the comp network of resistor R8 and capacitor C2 between the COMP pin and GND.
SLOPE	J5	Connect pins 1-2 for internal slope compensation configuration. Tie SLOPE to VCC. Connect pins 2-3 for external slope compensation configuration. Connect resistor R9 between the SLOPE pin and GND.

Table 3 describes the input and output connections.

Table 3. Input and Output Connections

Name	Designator	Description
VOUT	TP1	Banana jack connection to output. Connect to load.
PVIN	TP2	Banana jack connection to input. Connect to 12V DC supply.
GND	TP3	Banana jack connection to output GND. Connect to load ground.
GND	TP4	Banana jack connection to input GND. Connect to DC supply ground.
12V	TP16	Input supply to load transient gate driver. Connect to 12V DC supply.
GND	TP17	Connect to load transient gate driver supply ground.

Table 4 describes the test points.

Table 4. Test Points

Name	Designator	Description
VOUT	TP5	Output voltage test point.
PVIN	TP6	Input voltage test point.
LOOP	TP7	Signal injection point for loop response testing.
GND	TP8	GND test point for output.
GND	TP9	GND test point for input.
PG	TP10	Power good test point.
VCC	TP11	VCC supply test point.
SYNC	TP12	SYNC test point.
GND	TP13	GND test point.
GND	TP14	GND test point.
EN	TP15	Enable test point.
DRAIN	TP18	Test point at drain of load transient FET. Use to measure voltage across load resistors.
GATE	TP19	Load transient FET gate drive signal. Use to observe load transient control.

Table 4. Test Points (Cont.)

Name	Designator	Description
LX	J6	LX test point for oscilloscope probe
VOUT	J7	Output voltage test point for oscilloscope probe

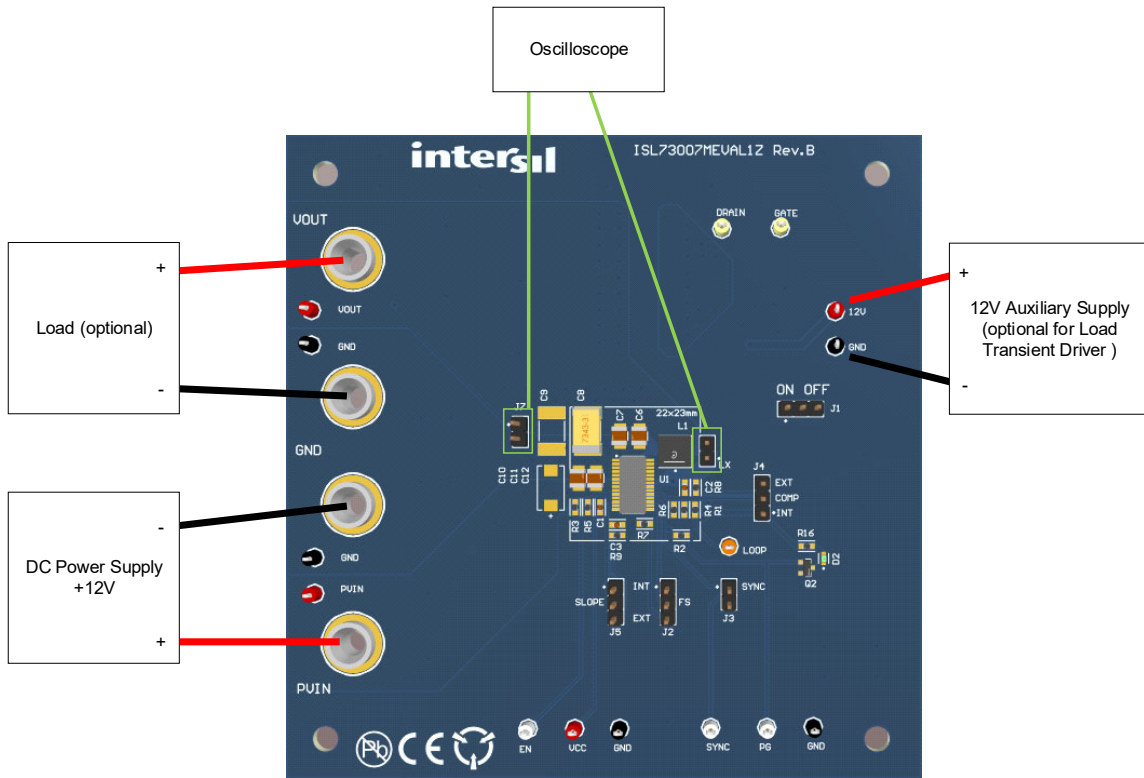

Figure 1. Basic Evaluation Test Setup Block Diagram

1.3 On-Board Load Transient Generator

An on-board load transient generator is available for fast slew rate load step testing. This circuit is shown in [Figure 5](#) and comprises of an open-drain active NMOS FET load switch, Q3, driven by a Renesas HIP2100 N-MOSFET driver. The HIP2100 requires 12V bias applied between TP16 (+12V) and TP17 (GND) for proper operation. The load current is set by a resistance between the NMOS drain and buck output voltage, VOUT. Six 2512 sized resistor SMD pads (R17 - R22) are made available for applying the required load resistance. The default load resistance is 1.1Ω.

The HIP2100 can be configured in an a-stable oscillation state where the load current is periodically pulsed, with the transient duration set by RC timing components. To set the HIP2100 in a-stable state, ensure jumper J1 is set to 1-2 (Load Transient enabled). In the first state, assume driver output HO = 0V, therefore MOSFET Q1 is off. This allows capacitor C5 to charge up with an RC time constant set by the total resistance of R10 and R11.

When the voltage across C5 (which is connected to HI) reaches the logic-high threshold of HI, HO goes into the second state and drives to a voltage HO = VDD. HO drives the Q3 MOSFET gate with turn-on (R12) and turn-off (R13) gate-limiting resistors. When HO is high, Q3 is on, and the buck output is loaded by the resistance across VOUT and Q3 drain.

At the same time, when HO is high, Q1 is now on and discharging C5 through R11 to GND. The discharge rate is dependent on the RC time constant formed by R11 and C5. When the voltage across C5 reaches the logic low threshold of HI, HO = 0, returning to its first state. The HIP2100 typical input thresholds are $V_{IH} = 5.8V$ and $V_{IL} = 5.4V$. The a-stable operation operates the HIP2100 between this hysteresis window of the HI input pin.

Time to discharge HI from V_{IH} to V_{IL} , or load active time, is represented in [Equation 1](#):

$$(EQ. 1) \quad t_{LoadOn} = -(R11 \times C5) \times \ln\left(\frac{V_{IL}}{V_{IH}}\right)$$

Time to charge HI from V_{IL} to V_{IH} , or load inactive time is represented in [Equation 2](#):

$$(EQ. 2) \quad t_{LoadOff} = -(R10 + R11) \times C5 \times \ln\left(\frac{V_{IH} - V_{DD}}{V_{IL} - V_{DD}}\right)$$

- The load active time with $R11 = 1k\Omega$ and $C5 = 10\mu F$ is approximately 700μs.
- The load inactive time with $R10 = 48.7k\Omega$, $R11 = 1k\Omega$ and $C5 = 10\mu F$ is approximately 30ms.

2. Board Design

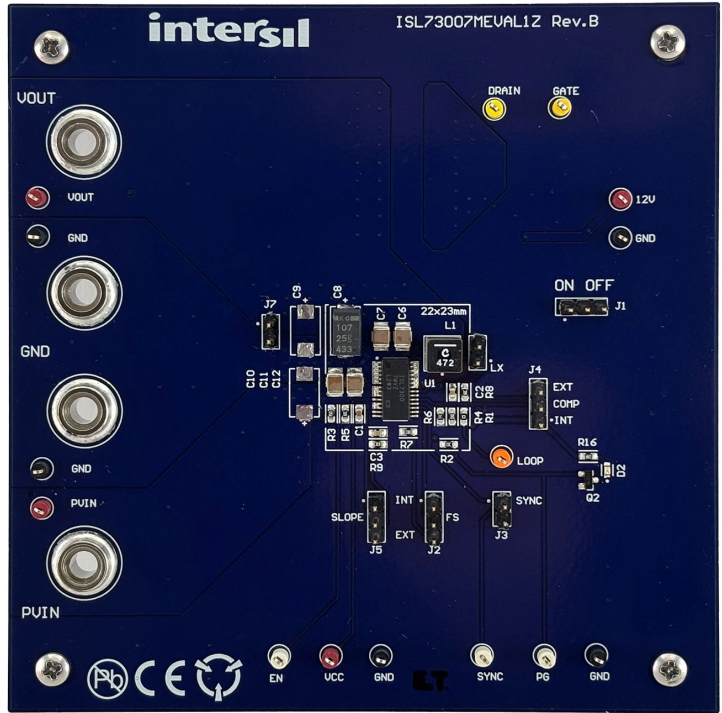

Figure 2. Evaluation Board (Top)

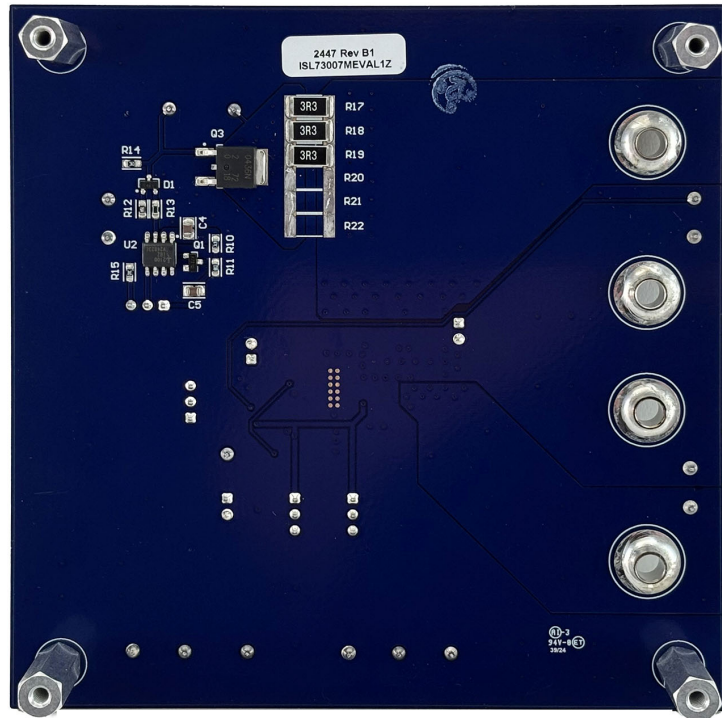

Figure 3. ISL73007MEVAL1Z Evaluation Board (Bottom)

2.1 Basic Layout

The ISL73007M is located in the center of the top side of the board and is labeled U1. The typical recommended layout for the given specifications is implemented in a compact 22mm×23mm area. Unused input and output capacitor footprints are located outside the typical solution area for the user to modify the board for alternate test conditions. The load transient generator circuit is placed on the bottom side of the PCB and is not a part of the typical application.

2.2 Layout Guidelines

PCB design is critical to reduce parasitic inductances with critical components being closely placed to the IC. The critical components in order would be feedback resistors, loop compensation resistor and capacitor, the slope resistor, and the low ESR ceramic input capacitors. Avoid placing any traces or components under the LX node to avoid noise coupling from the switching node. Refer to the datasheet for more details.

2.3 Component Selection

The default board is setup for 12V to 3.3V conversion. Table 5 outlines the component selection recommendations for evaluating common input voltage, output voltage, and switching frequency configurations. Replace these components as needed.

Table 5. Component Selection Table

V _{IN} (V)	V _{OUT} (V)	I _{OUT} (A)	f _{sw} (Hz)	L1 (μH)	C _{OUT} (μF)	C _{IN} (μF)	R _{FS} - R7 (kΩ)	R _{FB_Bot} - R6 (kΩ)	R _{SLOPE} - R9 (kΩ)	R _{COMP} - R8 (kΩ)	C _{COMP} - C2 (pF)	R _{EN_Bot} - R5 (kΩ)
12	3.3	3	500k	4.7 XGL5050-472MEC	144	44	100 or tie pin to VCC	2.21	44.2 or tie pin to VCC	15 or tie pin to VCC	3300 or tie pin to VCC	20
12	5	3	500k	5.6 XEL5050-562MEC	66	44	100 or tie pin to VCC	1.37	54.9 or tie pin to VCC	15 or tie pin to VCC	2200 or tie pin to VCC	20
5	2.5	3	1M	1.5 XGL4030-152MEC	122	44	42.7	3.16	44.2	14	2200	52.3
3.3	1.2	3	1M	0.82 XGL4020-821MEC	122	44	42.7	10	39.2	14	2200	100

2.4 Schematic Diagrams

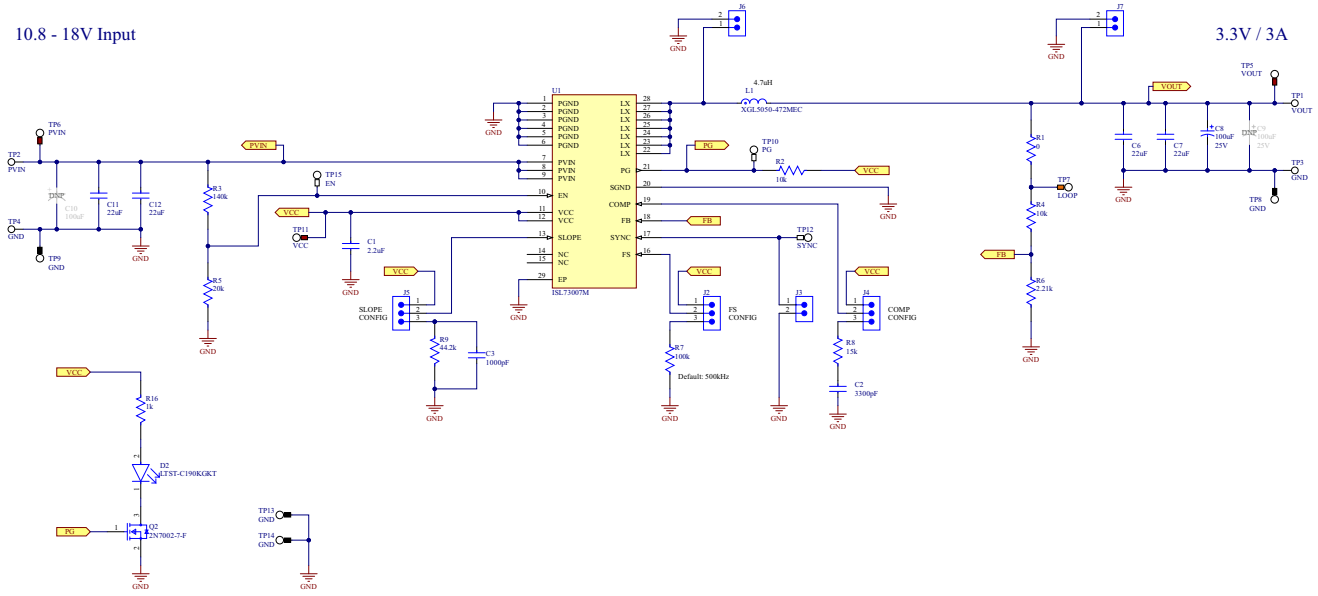

Figure 4. ISL73007MEVAL1Z Schematic

12V External Supply

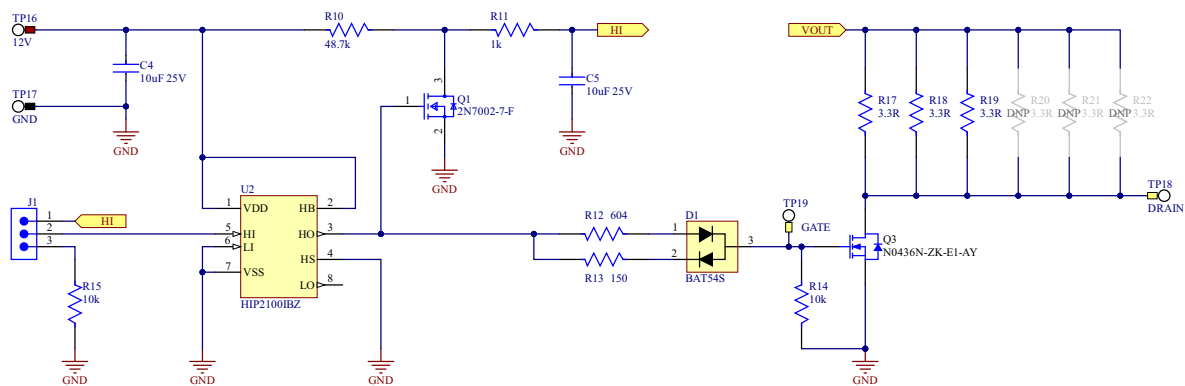

Figure 5. Transient Generator Schematic

2.5 Bill of Materials

Qty	Designator	Description	Manufacturer	Part Number
1	C1	Chip Multilayer Ceramic Capacitors for General Purpose, 0603, 2.2uF, X7R, 10%, 10V	Murata Electronics	GRM188R71A225KE15D-T
1	C2	Chip Multilayer Ceramic Capacitors for General Purpose, 0603, 3300pF, X7R, 10%, 16V	Yageo	C0603C332K4RACTU
1	C3	Chip Multilayer Ceramic Capacitors for General Purpose, 0603, 1000pF, X7R, 10%, 10V	Yageo	CC0603KRX7R6BB102-T
2	C4, C5	Multilayer Ceramic Capacitors 10uF ±10% 25V X7R SMD 0805	Murata Electronics	GRM21BZ71E106KE15L-T
4	C6, C7, C11, C12	Chip Multilayer Ceramic Capacitors for General Purpose, 1210, 22uF, X7R, 10%, 25V	Taiyo Yuden	TMK325B7226KM8P

Qty	Designator	Description	Manufacturer	Part Number
1	C8, C9	100µF Tantalum Polymer Capacitor 25 V 2917 (7343 Metric) 30mΩ	Kemet	T521X107M025ATE030
0	C10	CAP TANT 100µF 20% 25V 2917	Kemet	T491X107M025AT
1	D1	Diode Array SCHOTT 30V 200MA SOT23	Onsemi	BAT54S
1	D2	LED Green Clear Chip SMD	Lite-On Inc.	LTST-C190KGKT
4	J1, J2, J4, J5	Header, 3way, 1row, vertical	Würth Elektronik	61300311121
3	J3, J6, J7	Header, 2way, 1row, vertical	Würth Elektronik	61300211121
1	L1	Power Inductor, Shielded, Compos	Coilcraft	XGL5050-472MEC
4	MP1, MP2, MP3, MP4	1957 Standoff, 1/4 Hex M-F, Threaded (8-32), Length 0.500, Brass/Nickel	Keystone	1957
2	Q1, Q2	MOSFET N-CH 60V 115MA SOT23-3	Diodes Incorporated	2N7002-7-F
1	Q3	N-Channel MOSFET, 56A, 40V, 4.7mΩ, 3-Pin DPAK (TO-252)	Renesas	N0436N-ZK-E1-AY
1	R1	RES 0Ω 1% 1/10W 0603	Yageo	RC0603FR-070RL-T
4	R2, R4, R14, R15	RES 10kΩ 1% 1/10W 0603	Yageo	RC0603FR-0710KL-T
1	R3	RES 140kΩ 1% 1/10W 0603	Yageo	RC0603FR-07140KL-T
1	R5	RES 20kΩ 1% 1/10W 0603	Yageo	RC0603FR-0720KL-T
1	R6	RES 2.21kΩ 1% 1/10W 0603	Yageo	RMCF0603FT22K1-T
1	R7	RES 100kΩ 1% 1/10W 0603	Yageo	RC0603FR-07100KL-T
1	R8	RES 15kΩ 1% 1/10W 0603	Yageo	RC0603FR-0715KL-T
1	R9	RES 44.2kΩ 1% 1/10W 0603	Yageo	RC0603FR-0744K2L-T
1	R10	RES 48.7kΩ 1% 1/10W 0603	Yageo	RC0603FR-0748K7L-T
2	R11, R16	RES 1kΩ 1% 1/10W 0603	Yageo	RC0603FR-071KL-T
1	R12	RES 604Ω 1% 1/10W 0603	Yageo	RC0603FR-07604RL-T
1	R13	RES 150Ω 1% 1/10W 0603	Panasonic Electronic Components	ERJ-3EKF1500V-T
3	R17, R18, R19, R20, R21, R22	Res Thick Film 2512 3.3Ω 5% 1W ±300ppm/°C Pad SMD T/R	Samsung Electro-Mechanics	RC6432J3R3CS
4	TP1, TP2, TP3, TP4	Banana Jack, Non-Insulated, 1-Pin THD, RoHS, Bulk	Keystone	575-4
4	TP5, TP6, TP11, TP16	Test Point, wire loop, RED nylon sleeve, miniature	Keystone	5000
1	TP7	Test Point, wire loop, ORANGE nylon sleeve, miniature	Keystone	5003
5	TP8, TP9, TP13, TP14, TP17	Test Point, wire loop, BLACK nylon sleeve, miniature	Keystone	5001
3	TP10, TP12, TP15	Test Point, wire loop, WHITE nylon sleeve, miniature	Keystone	5002
2	TP18, TP19	Test Point, wire loop, YELLOW nylon sleeve, miniature	Keystone	5004
1	U1	Radiation Tolerant 18V, 3A Point-of-Load Regulator	Renesas	ISL73007M30VZ
1	U2	HIP2100IBZ HIP2100 Series Low Side/High Side N-Ch 114 V 2 A Half Bridge Driver - SOIC-8	Renesas	HIP2100IBZ

2.6 Board Layout

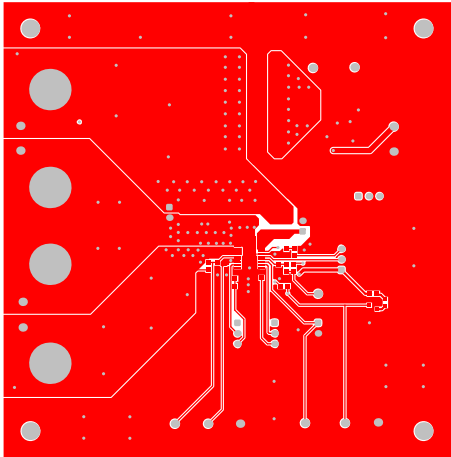

Figure 6. Top Layer

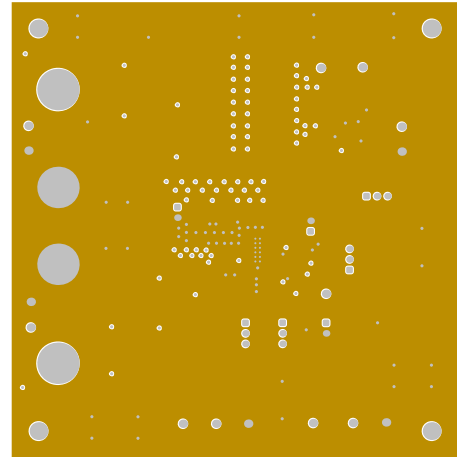

Figure 7. Layer 2

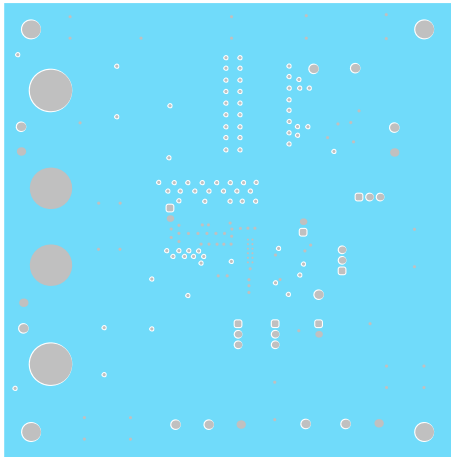

Figure 8. Layer 3

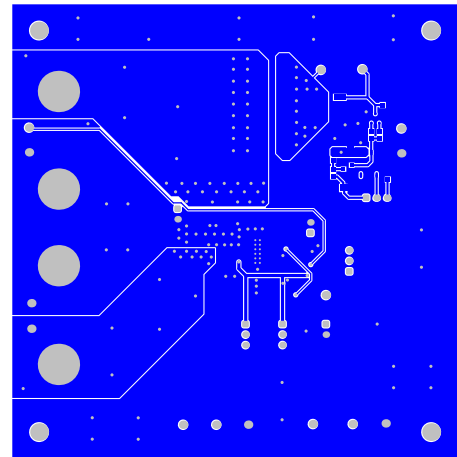

Figure 9. Bottom Layer

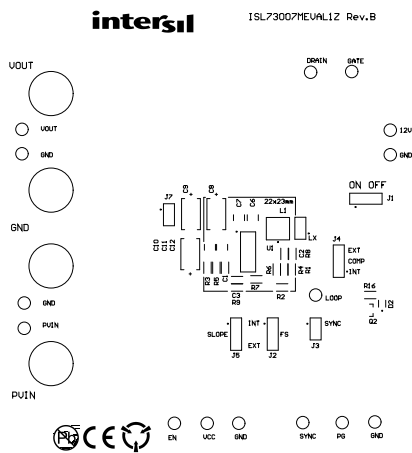

Figure 10. Top Silk Layer

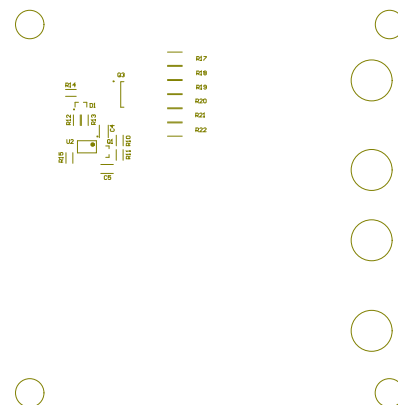

Figure 11. Bottom Silk Layer

3. Typical Performance Graphs

Unless otherwise noted, $P_{VIN} = 12V$; $V_{OUT} = 3.3V$, $f_{SW} = 500kHz$, $T_A = \text{Room Ambient}$

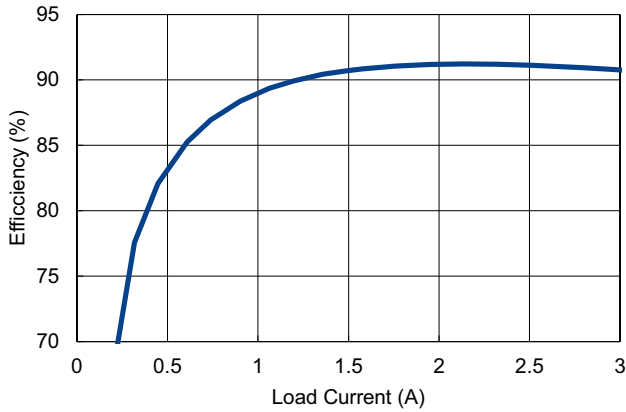

Figure 12. Efficiency

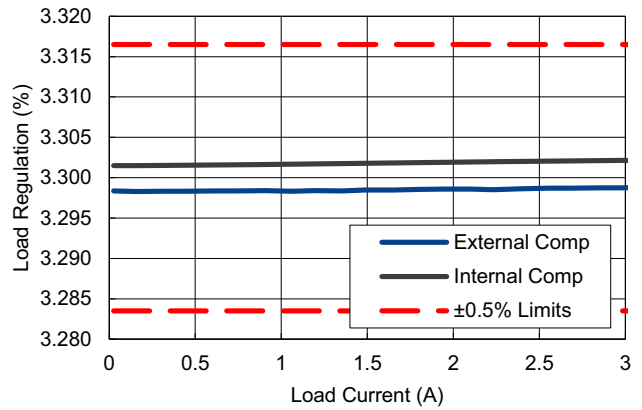

Figure 13. Load Regulation Int & Ext comp

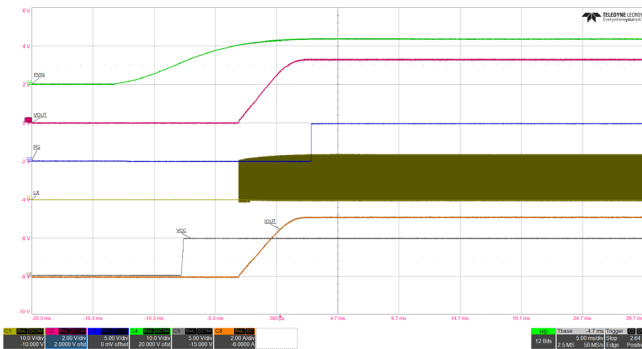

Figure 14. Turn-on by PVIN, 1.1Ω load

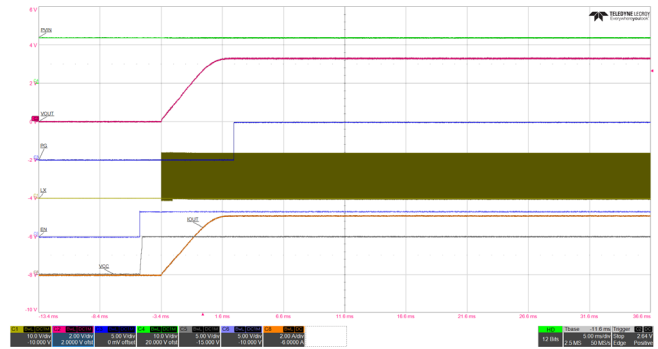

Figure 15. Enabled Turn-on, 1.1Ω load

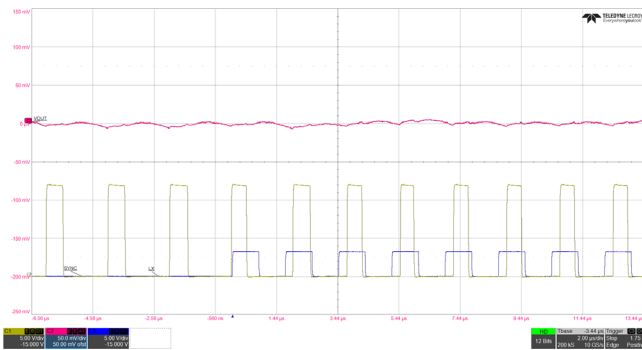

Figure 16. 575kHz SYNC Input Start

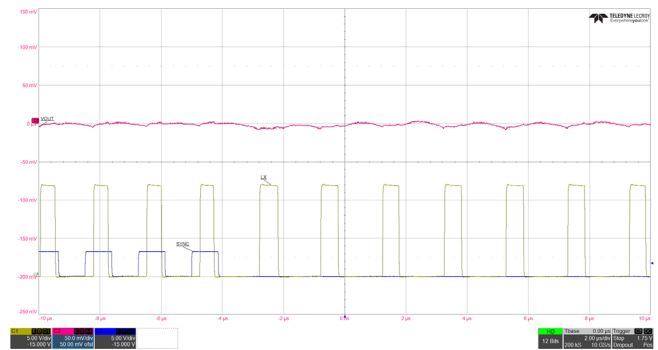

Figure 17. 575kHz SYNC Input Stop

Unless otherwise noted, $P_{VIN} = 12V$; $V_{OUT} = 3.3V$, $f_{SW} = 500kHz$, $T_A = \text{Room Ambient}$ (Cont.)

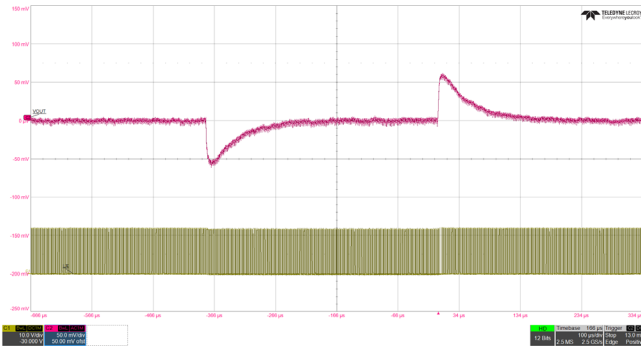

Figure 18. 1A DC (3.3Ω Load) with 2A Load Transient (External Compensation)

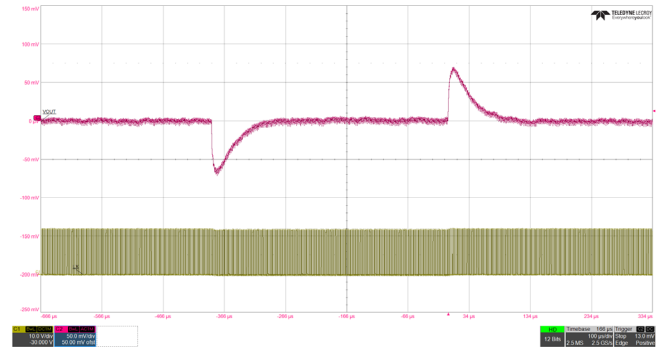

Figure 19. 1A DC (3.3Ω Load) with 2A Load Transient (Internal Compensation)

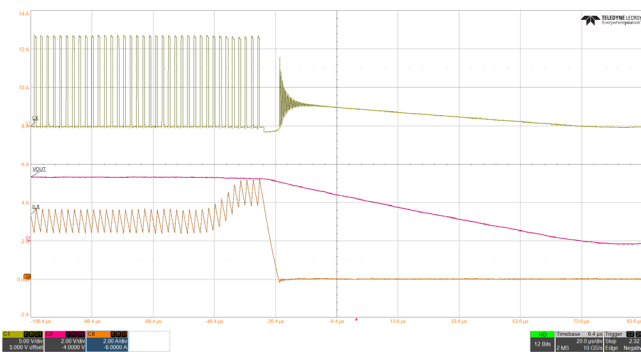

Figure 20. Positive Overcurrent Protection

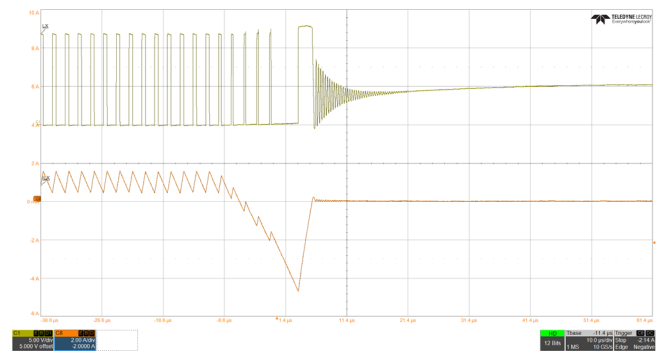

Figure 21. Negative Overcurrent Protection

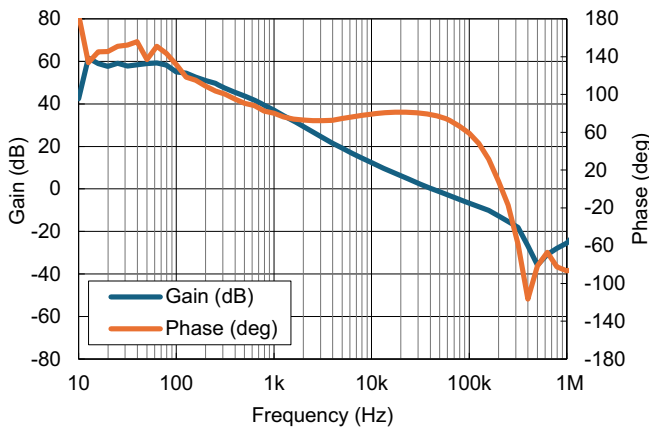

Figure 22. Bode Plot: External Comp, $P_{VIN} = 12V$, $V_{OUT} = 3.3V$, $I_{OUT} = 3A$

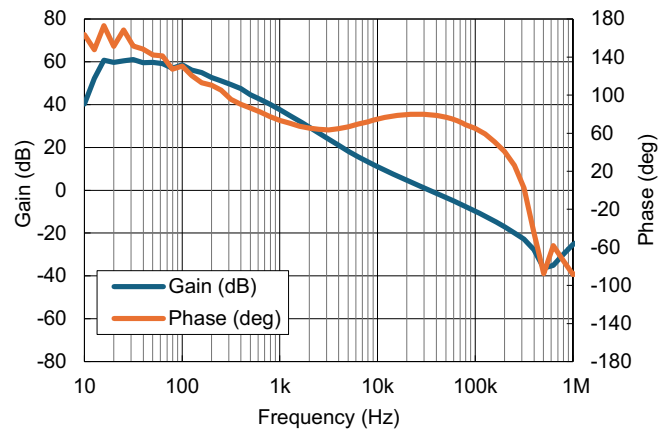

Figure 23. Bode Plot: Internal Comp, $P_{VIN} = 12V$, $V_{OUT} = 3.3V$, $I_{OUT} = 3A$

4. Ordering Information

Part Number	Description
ISL73007MEVAL1Z	Radiation Tolerant ISL73007M buck regulator evaluation board

5. Revision History

Revision	Date	Description
1.01	May 14, 2026	Add Figures 22 and 23.
1.00	Feb 28, 2025	Initial release

IMPORTANT NOTICE AND DISCLAIMER

RENESAS ELECTRONICS CORPORATION AND ITS SUBSIDIARIES (“RENESAS”) PROVIDES TECHNICAL SPECIFICATIONS AND RELIABILITY DATA (INCLUDING DATASHEETS), DESIGN RESOURCES (INCLUDING REFERENCE DESIGNS), APPLICATION OR OTHER DESIGN ADVICE, WEB TOOLS, SAFETY INFORMATION, AND OTHER RESOURCES “AS IS” AND WITH ALL FAULTS, AND DISCLAIMS ALL WARRANTIES, EXPRESS OR IMPLIED, INCLUDING, WITHOUT LIMITATION, ANY IMPLIED WARRANTIES OF MERCHANTABILITY, FITNESS FOR A PARTICULAR PURPOSE, OR NON-INFRINGEMENT OF THIRD-PARTY INTELLECTUAL PROPERTY RIGHTS.

These resources are intended for developers who are designing with Renesas products. You are solely responsible for (1) selecting the appropriate products for your application, (2) designing, validating, and testing your application, and (3) ensuring your application meets applicable standards, and any other safety, security, or other requirements. These resources are subject to change without notice. Renesas grants you permission to use these resources only to develop an application that uses Renesas products. Other reproduction or use of these resources is strictly prohibited. No license is granted to any other Renesas intellectual property or to any third-party intellectual property. Renesas disclaims responsibility for, and you will fully indemnify Renesas and its representatives against, any claims, damages, costs, losses, or liabilities arising from your use of these resources. Renesas' products are provided only subject to Renesas' Terms and Conditions of Sale or other applicable terms agreed to in writing. No use of any Renesas resources expands or otherwise alters any applicable warranties or warranty disclaimers for these products.

(Disclaimer Rev.1.01)

Corporate Headquarters

TOYOSU FORESIA, 3-2-24 Toyosu,
Koto-ku, Tokyo 135-0061, Japan
www.renesas.com

Trademarks

Renesas and the Renesas logo are trademarks of Renesas Electronics Corporation. All trademarks and registered trademarks are the property of their respective owners.

Contact Information

For further information on a product, technology, the most up-to-date version of a document, or your nearest sales office, please visit www.renesas.com/contact-us/.