

ISL1561IRZ-EVALZ

Evaluation Board

AN1812
Rev 0.00
May 8, 2014

General Description

The ISL1561IRZ-EVALZ is a fixed gain dual port class-G differential amplifier designed for driving ADSL2+ and VDSL2 signals at very low power dissipation. The current feedback amplifiers operate on a single +14V power supply and internally generates higher supply voltages when needed to enable efficient power operation.

A USB micro-controller is integrated into the board to program the registers in the ISL1561 through a 3-pin serial protocol interface (SPI). Evaluation software is included in the evaluation kit to program the registers and set the quiescent current for each port at 0.5mA steps.

Detailed Description

SPI Control

The micro-controller uses 4 logic signals (SCLK, SDI, SDO and CS) to communicate with ISL1561's 3-pin SPI: SCLK, SDATA and CS. Since SDATA for the ISL1561 is used for both data in and data out, a series of 10kΩ resistors are placed between SDI and SDO with SDI connected directly to SDATA in order for the micro-controller to read the registers in ISL1561.

Evaluation Software

The GUI software is available to program the ISL1561IRZ-EVALZ evaluation board. Running the "ISL1561_Installer_V1.0.exe" will install the needed drivers for the program. The program files will be installed in "C:\Program Files\Intersil\ISL1561" and the file to run is "ISL1561.exe". When running the program, be sure the micro-controller is connected to the computer's USB port.

The ISL1561 starts up in disable mode. Clicking "Read All" will make both registers display "80". The two register boxes allow users to write and read. For example, when a user clicks in the box and types "0F", the program also enters in the same box the read register value, which is also "0F". If a different value is displayed, the register is not programmed correctly.

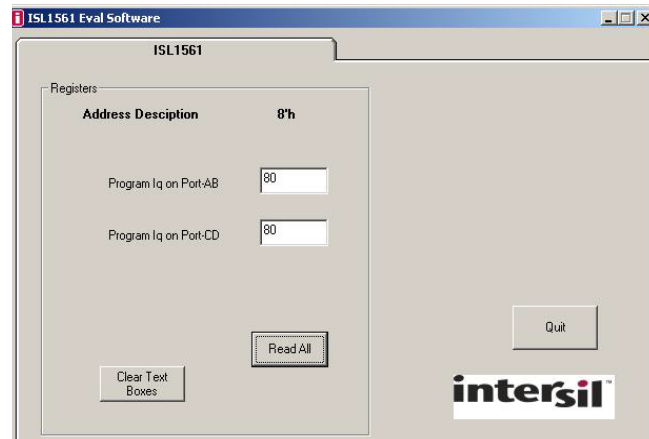

FIGURE 1. WINDOW'S GUI

Programming Quiescent Current

Table 1 lists quiescent current given the values entered in the register boxes. The register boxes in the GUI accept hexadecimal. Entering "0F" in the box will change the quiescent current to 7.2mA for that port. To change to a different value, users can click in the box to highlight the previous value and enter a new value.

TABLE 1. REGISTER VALUES vs Iq

VALUES IN EITHER PORTAB OR PORTCD BOX	Iq PER PORT (mA)
80	2.5
0F	7.2
1C	10.3
7F	19.5

When the previous value is highlighted, users can also use the up and down arrow keys on the keyboard to change the value. If the current value is "0F", pressing the arrow key down will change the value to "0E" and pressing the key up will change the value to "10". Each step changes quiescent current by 500µA for the selected port.

The range of quiescent current for each port with the most significant bit (MSB) low is 8'h00 to 8'h7F and with the most significant bit (MSB) high is 8'h80 to 8'hFF. To change the quiescent current to 10.3mA/port, entering "1C" is the same as entering "9C" in the registers. The later sets the MSB high. Be careful when setting the MSB high for both ports because this will over-ride the boost operation as shown in Table 2 of the [ISL1561](#) datasheet.

When verifying reading and writing to the registers on an oscilloscope, note that the least significant bit (LSB) is loaded first and the most significant bit (MSB) is loaded last. The scope will display a "FO" instead of a "0F" because the micro-controller reads MSB first. Bit swapping was implemented on the software to load LSB first.

Figure 2 is a scope capture of SDATA in yellow, SCLK in red and CS in blue. From left to right, SDATA shows the first bit is low, which defines read. The next 3 bits, 110, defines reg3 as being read. The following 8 bits, 11110000, defines reg3 as the value of "FO". Reading and writing to the register only occurs when CS is held low.



FIGURE 2. SDATA = "F0" IN PORTAB (reg3)

Board Design Recommendation

The ISL1561 is recommended to operate with less than 45pF of common mode parasitic on any of the four outputs. To minimize parasitic capacitance in the ISL1561 design, consider laying out short output traces and choosing low capacitance protection devices and line transformers with low interwinding capacitance in the signal path.

Close placement of the boost capacitors to the boost pins is necessary to minimize parasitic inductance in the boost supply path. On the ISL1561IRZ-EVALZ evaluation board, 1 μ F and 2.2 μ F capacitors are used instead of one in order to place the smaller footprint, a 1 μ F capacitor, close to the boost pins. An increase in ringing at the outputs caused by the rising edge of each boost event is observed if the boost capacitors are moved away from the package pins. Adding 5 Ω in series to the boost capacitors will help reduce this common mode ringing.

The supply decoupling capacitors are also placed close to the supply pins to minimize parasitic inductance in the supply path. High frequency load currents are typically pulled through these capacitors, so close placement of the 0.1 μ F capacitors on the supply pin will improve dynamic performance. The higher 2.2 μ F value capacitors can be placed further from the supply pins as they provide low frequency decoupling.

The thermal pad for the ISL1561 should be connected to ground. For good thermal control, running vias to a bottom pad helps dissipate heat away from the package.

Output Resistor Loading

In DSL applications, a line transformer is placed between the line driver and 100 Ω line. When the transformer is not available, an equivalent resistor load can be used. On PortAB, R6, R7, R10 and R12 allow for 100 Ω connected across OUTA-OUTB while keeping the load seen by the line driver 51 Ω (51 Ω is calculated from using a 1:1.4 transformer with 100 Ω on the line). When 100 Ω is connected across OUTA-OUTB, the resistor divider network attenuates the signal by -23.2dB.

ISL1561IRZ-EVALZ Evaluation Board Schematic

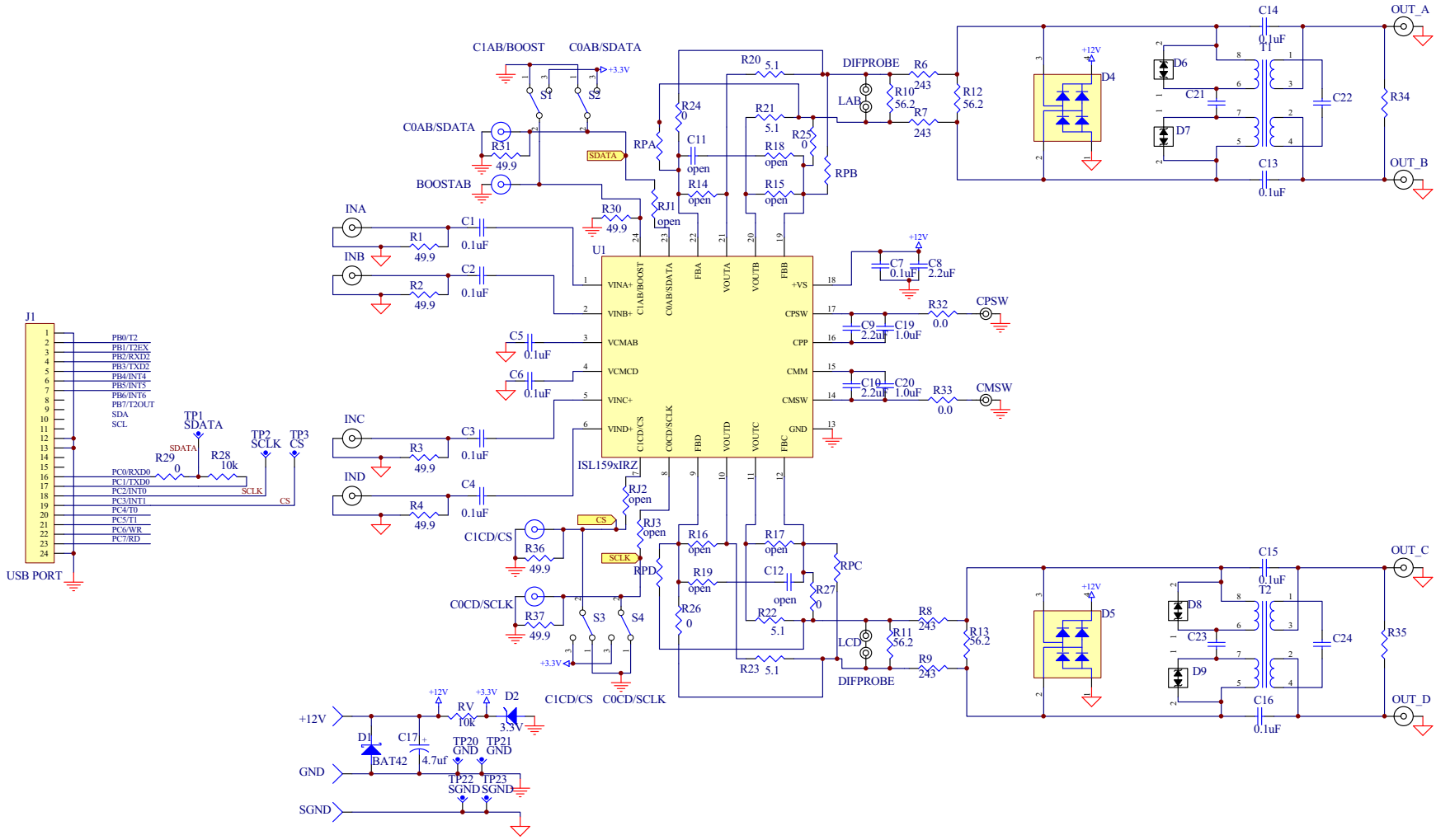

Bill of Materials

DESIGNATION	QTY	DESCRIPTION	MANUFACTURER	MFG. PART NUMBER
IC	1	ISL1561IRZ	INTERSIL	ISL1561IRZ
None	1	Printed Circuit Board		ISL1561IRZ Eval Board
C1-C7	7	0.1 μ F, Ceramic Capacitors	ANY	0603
C8	1	2.2 μ F, Ceramic Capacitors	ANY	0603
C9, C10	2	2.2 μ F, Ceramic Capacitor	ANY	0805
C13-C16	4	0.1 μ F, Ceramic Capacitor	ANY	0805
C17	1	4.7 μ F, 25V, Ceramic Capacitor	ANY	3528
C19, C20	2	1.0 μ F, Ceramic Capacitor	ANY	0402
C21, C23	2	Open	ANY	1812
C22, C24	2	Open	ANY	-
R1-R4, R30, R31, R36, R37	8	49.9 Ω , 1% Ceramic Resistor	ANY	0603
R6-R9	4	243 Ω , 1% Ceramic Resistors	ANY	0805
R10-R13	4	56.2 Ω , 1% Ceramic Resistor	ANY	0805
R20-R23	4	5.1 Ω , 1% Ceramic Resistor	ANY	0805
R24-R27, R29	5	0.0 Ω , 1% Ceramic Resistor	ANY	0603
R28	1	10k Ω , 1% Ceramic Resistor	ANY	0603
R32, R33	2	0.0 Ω , 1% Ceramic Resistor	ANY	0402
RV	1	Open	ANY	0805
C11, C12, R14-R19, RJ1, RJ2, RJ3, RPA, RPB, RPC, RPD	15	Open	ANY	0603
R34, R35	2	Open	ANY	-
D1	1	Schottky Diode	ANY	SOD-123
D2	1	3.3V Zener Diode	ANY	SOD-123
D4, D5	2	Open	ANY	SOT-143
D6-D9	4	Open	ANY	SOD-323
S1-S4	4	Open	Toggle Switch GT11MCKE	-
T1, T2	2	Open	ANY	-
14V, SGND, GND	4	Banana Jack	ANY	4-Pin
INA-IND, OUTA-OUTD, CS, SDATA, SCLK	10	BNC	ANY	-
	4	6-32x.375"Lg., Phillips Pan Head	OLANDER	6C37PPMS
	4	6-32x.50"Lg., Hex Standoff, 1/4" Hex Dia	OLANDER	6C50HF4U

Evaluation Board Layout

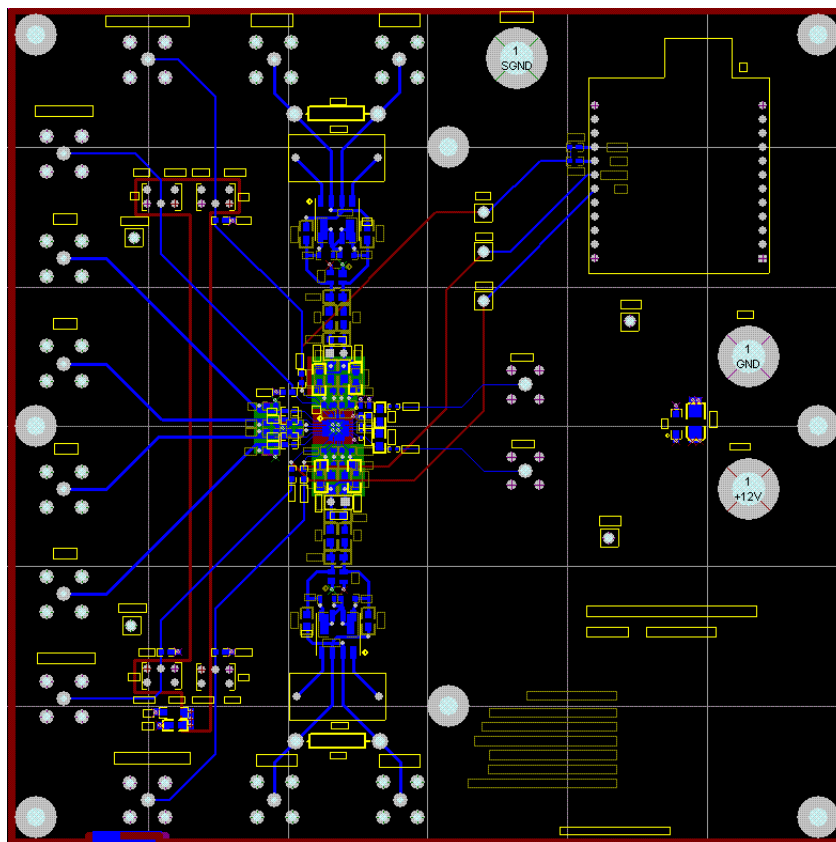

FIGURE 3. TOP VIEW

Notice

1. Descriptions of circuits, software and other related information in this document are provided only to illustrate the operation of semiconductor products and application examples. You are fully responsible for the incorporation or any other use of the circuits, software, and information in the design of your product or system. Renesas Electronics disclaims any and all liability for any losses and damages incurred by you or third parties arising from the use of these circuits, software, or information.
2. Renesas Electronics hereby expressly disclaims any warranties against and liability for infringement or any other claims involving patents, copyrights, or other intellectual property rights of third parties, by or arising from the use of Renesas Electronics products or technical information described in this document, including but not limited to, the product data, drawings, charts, programs, algorithms, and application examples.
3. No license, express, implied or otherwise, is granted hereby under any patents, copyrights or other intellectual property rights of Renesas Electronics or others.
4. You shall not alter, modify, copy, or reverse engineer any Renesas Electronics product, whether in whole or in part. Renesas Electronics disclaims any and all liability for any losses or damages incurred by you or third parties arising from such alteration, modification, copying or reverse engineering.
5. Renesas Electronics products are classified according to the following two quality grades: "Standard" and "High Quality". The intended applications for each Renesas Electronics product depends on the product's quality grade, as indicated below.
"Standard": Computers; office equipment; communications equipment; test and measurement equipment; audio and visual equipment; home electronic appliances; machine tools; personal electronic equipment; industrial robots; etc.
"High Quality": Transportation equipment (automobiles, trains, ships, etc.); traffic control (traffic lights); large-scale communication equipment; key financial terminal systems; safety control equipment; etc.
Unless expressly designated as a high reliability product or a product for harsh environments in a Renesas Electronics data sheet or other Renesas Electronics document, Renesas Electronics products are not intended or authorized for use in products or systems that may pose a direct threat to human life or bodily injury (artificial life support devices or systems; surgical implantations; etc.), or may cause serious property damage (space system; undersea repeaters; nuclear power control systems; aircraft control systems; key plant systems; military equipment; etc.). Renesas Electronics disclaims any and all liability for any damages or losses incurred by you or any third parties arising from the use of any Renesas Electronics product that is inconsistent with any Renesas Electronics data sheet, user's manual or other Renesas Electronics document.
6. When using Renesas Electronics products, refer to the latest product information (data sheets, user's manuals, application notes, "General Notes for Handling and Using Semiconductor Devices" in the reliability handbook, etc.), and ensure that usage conditions are within the ranges specified by Renesas Electronics with respect to maximum ratings, operating power supply voltage range, heat dissipation characteristics, installation, etc. Renesas Electronics disclaims any and all liability for any malfunctions, failure or accident arising out of the use of Renesas Electronics products outside of such specified ranges.
7. Although Renesas Electronics endeavors to improve the quality and reliability of Renesas Electronics products, semiconductor products have specific characteristics, such as the occurrence of failure at a certain rate and malfunctions under certain use conditions. Unless designated as a high reliability product or a product for harsh environments in a Renesas Electronics data sheet or other Renesas Electronics document, Renesas Electronics products are not subject to radiation resistance design. You are responsible for implementing safety measures to guard against the possibility of bodily injury, injury or damage caused by fire, and/or danger to the public in the event of a failure or malfunction of Renesas Electronics products, such as safety design for hardware and software, including but not limited to redundancy, fire control and malfunction prevention, appropriate treatment for aging degradation or any other appropriate measures. Because the evaluation of microcomputer software alone is very difficult and impractical, you are responsible for evaluating the safety of the final products or systems manufactured by you.
8. Please contact a Renesas Electronics sales office for details as to environmental matters such as the environmental compatibility of each Renesas Electronics product. You are responsible for carefully and sufficiently investigating applicable laws and regulations that regulate the inclusion or use of controlled substances, including without limitation, the EU RoHS Directive, and using Renesas Electronics products in compliance with all these applicable laws and regulations. Renesas Electronics disclaims any and all liability for damages or losses occurring as a result of your noncompliance with applicable laws and regulations.
9. Renesas Electronics products and technologies shall not be used for or incorporated into any products or systems whose manufacture, use, or sale is prohibited under any applicable domestic or foreign laws or regulations. You shall comply with any applicable export control laws and regulations promulgated and administered by the governments of any countries asserting jurisdiction over the parties or transactions.
10. It is the responsibility of the buyer or distributor of Renesas Electronics products, or any other party who distributes, disposes of, or otherwise sells or transfers the product to a third party, to notify such third party in advance of the contents and conditions set forth in this document.
11. This document shall not be reprinted, reproduced or duplicated in any form, in whole or in part, without prior written consent of Renesas Electronics.
12. Please contact a Renesas Electronics sales office if you have any questions regarding the information contained in this document or Renesas Electronics products.
(Note 1) "Renesas Electronics" as used in this document means Renesas Electronics Corporation and also includes its directly or indirectly controlled subsidiaries.
(Note 2) "Renesas Electronics product(s)" means any product developed or manufactured by or for Renesas Electronics.

(Rev.4.0-1 November 2017)



SALES OFFICES

Renesas Electronics Corporation

<http://www.renesas.com>

Refer to "<http://www.renesas.com/>" for the latest and detailed information.

Renesas Electronics America Inc.
1001 Murphy Ranch Road, Milpitas, CA 95035, U.S.A.
Tel: +1-408-432-8888, Fax: +1-408-434-5351

Renesas Electronics Canada Limited
9251 Yonge Street, Suite 8309 Richmond Hill, Ontario Canada L4C 9T3
Tel: +1-905-237-2004

Renesas Electronics Europe Limited
Dukes Meadow, Millboard Road, Bourne End, Buckinghamshire, SL8 5FH, U.K
Tel: +44-1628-651-700, Fax: +44-1628-651-804

Renesas Electronics Europe GmbH
Arcadiastrasse 10, 40472 Düsseldorf, Germany
Tel: +49-211-6503-0, Fax: +49-211-6503-1327

Renesas Electronics (China) Co., Ltd.
Room 1709 Quantum Plaza, No.27 ZhichunLu, Haidian District, Beijing, 100191 P. R. China
Tel: +86-10-8235-1155, Fax: +86-10-8235-7679

Renesas Electronics (Shanghai) Co., Ltd.
Unit 301, Tower A, Central Towers, 555 Langao Road, Putuo District, Shanghai, 200333 P. R. China
Tel: +86-21-2226-0888, Fax: +86-21-2226-0999

Renesas Electronics Hong Kong Limited
Unit 1601-1611, 16/F., Tower 2, Grand Century Place, 193 Prince Edward Road West, Mongkok, Kowloon, Hong Kong
Tel: +852-2265-6688, Fax: +852-2886-9022

Renesas Electronics Taiwan Co., Ltd.
13F, No. 363, Fu Shing North Road, Taipei 10543, Taiwan
Tel: +886-2-8175-9600, Fax: +886-2-8175-9670

Renesas Electronics Singapore Pte. Ltd.
80 Bendemeer Road, Unit #06-02 Hyflux Innovation Centre, Singapore 339949
Tel: +65-6213-0200, Fax: +65-6213-0300

Renesas Electronics Malaysia Sdn.Bhd.
Unit 1207, Block B, Menara Amcorp, Amcorp Trade Centre, No. 18, Jln Persiaran Barat, 46050 Petaling Jaya, Selangor Darul Ehsan, Malaysia
Tel: +60-3-7955-9390, Fax: +60-3-7955-9510

Renesas Electronics India Pvt. Ltd.
No.777C, 100 Feet Road, HAL 2nd Stage, Indiranagar, Bangalore 560 038, India
Tel: +91-80-67208700, Fax: +91-80-67208777

Renesas Electronics Korea Co., Ltd.
17F, KAMCO Yangjae Tower, 262, Gangnam-daero, Gangnam-gu, Seoul, 06265 Korea
Tel: +82-2-558-3737, Fax: +82-2-558-5338