

NEC

User's Manual

IE-703177-NW-EM

In-Circuit Emulator Option Board

Target Device

V850E/CG2™ CARGATE-F

NOTES FOR CMOS DEVICES

① PRECAUTION AGAINST ESD FOR SEMICONDUCTORS

Note:

Strong electric field, when exposed to a MOS device, can cause destruction of the gate oxide and ultimately degrade the device operation. Steps must be taken to stop generation of static electricity as much as possible, and quickly dissipate it once, when it has occurred. Environmental control must be adequate. When it is dry, humidifier should be used. It is recommended to avoid using insulators that easily build static electricity. Semiconductor devices must be stored and transported in an anti-static container, static shielding bag or conductive material. All test and measurement tools including work bench and floor should be grounded. The operator should be grounded using wrist strap. Semiconductor devices must not be touched with bare hands. Similar precautions need to be taken for PW boards with semiconductor devices on it.

② HANDLING OF UNUSED INPUT PINS FOR CMOS

Note:

No connection for CMOS device inputs can be cause of malfunction. If no connection is provided to the input pins, it is possible that an internal input level may be generated due to noise, etc., hence causing malfunction. CMOS devices behave differently than Bipolar or NMOS devices. Input levels of CMOS devices must be fixed high or low by using a pull-up or pull-down circuitry. Each unused pin should be connected to V_{DD} or GND with a resistor, if it is considered to have a possibility of being an output pin. All handling related to the unused pins must be judged device by device and related specifications governing the devices.

③ STATUS BEFORE INITIALIZATION OF MOS DEVICES

Note:

Power-on does not necessarily define initial status of MOS device. Production process of MOS does not define the initial operation status of the device. Immediately after the power source is turned ON, the devices with reset function have not yet been initialized. Hence, power-on does not guarantee out-pin levels, I/O settings or contents of registers. Device is not initialized until the reset signal is received. Reset operation must be executed immediately after power-on for devices having reset function.

- The information in this document is current as of 26.02, 2003. The information is subject to change without notice. For actual design-in, refer to the latest publications of NEC Electronics data sheets or data books, etc., for the most up-to-date specifications of NEC Electronics products. Not all products and/or types are available in every country. Please check with an NEC sales representative for availability and additional information.
- No part of this document may be copied or reproduced in any form or by any means without prior written consent of NEC Electronics. NEC Electronics assumes no responsibility for any errors that may appear in this document.
- NEC Electronics does not assume any liability for infringement of patents, copyrights or other intellectual property rights of third parties by or arising from the use of NEC Electronics products listed in this document or any other liability arising from the use of such NEC Electronics products. No license, express, implied or otherwise, is granted under any patents, copyrights or other intellectual property rights of NEC Electronics or others.
- Descriptions of circuits, software and other related information in this document are provided for illustrative purposes in semiconductor product operation and application examples. The incorporation of these circuits, software and information in the design of customer's equipment shall be done under the full responsibility of customer. NEC Electronics no responsibility for any losses incurred by customers or third parties arising from the use of these circuits, software and information.
- While NEC Electronics endeavors to enhance the quality, reliability and safety of NEC Electronics products, customers agree and acknowledge that the possibility of defects thereof cannot be eliminated entirely. To minimize risks of damage to property or injury (including death) to persons arising from defects in NEC Electronics products, customers must incorporate sufficient safety measures in their design, such as redundancy, fire-containment and anti-failure features.
- NEC Electronics products are classified into the following three quality grades: "Standard", "Special" and "Specific".

The "Specific" quality grade applies only to NEC Electronics products developed based on a customer-designated "quality assurance program" for a specific application. The recommended applications of NEC Electronics product depend on its quality grade, as indicated below. Customers must check the quality grade of each NEC Electronics product before using it in a particular application.

"Standard": Computers, office equipment, communications equipment, test and measurement equipment, audio and visual equipment, home electronic appliances, machine tools, personal electronic equipment and industrial robots.

"Special": Transportation equipment (automobiles, trains, ships, etc.), traffic control systems, anti-disaster systems, anti-crime systems, safety equipment and medical equipment (not specifically designed for life support).

"Specific": Aircraft, aerospace equipment, submersible repeaters, nuclear reactor control systems, life support systems and medical equipment for life support, etc.

The quality grade of NEC Electronics products is "Standard" unless otherwise expressly specified in NEC Electronics data sheets or data books, etc. If customers wish to use NEC Electronics products in applications not intended by NEC Electronics, they must contact NEC Electronics sales representative in advance to determine NEC Electronics 's willingness to support a given application.

- Notes:**
1. " NEC Electronics" as used in this statement means NEC Electronics Corporation and also includes its majority-owned subsidiaries.
 2. " NEC Electronics products" means any product developed or manufactured by or for NEC Electronics (as defined above).

M8E 02.10

Regional Information

Some information contained in this document may vary from country to country. Before using any NEC product in your application, please contact the NEC office in your country to obtain a list of authorized representatives and distributors. They will verify:

- Device availability
- Ordering information
- Product release schedule
- Availability of related technical literature
- Development environment specifications (for example, specifications for third-party tools and components, host computers, power plugs, AC supply voltages, and so forth)
- Network requirements

In addition, trademarks, registered trademarks, export restrictions, and other legal issues may also vary from country to country.

NEC Electronics Inc. (U.S.)

Santa Clara, California
Tel: 408-588-6000
800-366-9782
Fax: 408-588-6130
800-729-9288

NEC Electronics (Europe) GmbH

Duesseldorf, Germany
Tel: 0211-65 03 01
Fax: 0211-65 03 327

Sucursal en España

Madrid, Spain
Tel: 091- 504 27 87
Fax: 091- 504 28 60

Succursale Française

Vélizy-Villacoublay, France
Tel: 01-30-67 58 00
Fax: 01-30-67 58 99

Filiale Italiana

Milano, Italy
Tel: 02-66 75 41
Fax: 02-66 75 42 99

Branch The Netherlands

Eindhoven, The Netherlands
Tel: 040-244 58 45
Fax: 040-244 45 80

Branch Sweden

Taeby, Sweden
Tel: 08-63 80 820
Fax: 08-63 80 388

United Kingdom Branch

Milton Keynes, UK
Tel: 01908-691-133
Fax: 01908-670-290

NEC Electronics Hong Kong Ltd.

Hong Kong
Tel: 2886-9318
Fax: 2886-9022/9044

NEC Electronics Hong Kong Ltd.

Seoul Branch
Seoul, Korea
Tel: 02-528-0303
Fax: 02-528-4411

NEC Electronics Singapore Pte. Ltd.

Singapore
Tel: 65-253-8311
Fax: 65-250-3583

NEC Electronics Taiwan Ltd.

Taipei, Taiwan
Tel: 02-2719-2377
Fax: 02-2719-5951

NEC do Brasil S.A.

Electron Devices Division
Guarulhos, Brasil
Tel: 55-11-6465-6810
Fax: 55-11-6465-6829

Introduction

- Readers** This manual is intended for users who design and develop application systems using the V850E/CG2™ CARGATE-F.
- Purpose** The purpose of this manual is to describe the proper operation of the IE-703177-NW-EM, and their basic specifications.
- Organization** This manual is broadly divided into the following parts:
- Overview
 - Name and function of components
 - Factory settings
 - Cautions
 - Debugger operation
 - Limitations
- How to Read This Manual** It is assumed that the reader of this manual has general knowledge of electrical engineering, logic circuits, and microcontrollers.
- The IE-703177-NW-EM are used connected to the RTE-1000-TP-EE in-circuit emulator. This manual explains the basic setup procedure and switch settings of the IE-703177-NW-EM. For the names and functions, and the connection of parts, refer to the **RTE-1000-TP-EE User's Manual**, which is a separate volume.
- To understand the basic specifications and operation methods broadly
→ Read this manual in the order listed in **CONTENTS**.
- To know the operation methods and command functions of the RTE-1000-TP-EE, IE-703177-NW-EM.
→ Read the user's manual of the debugger (separate volume) that is used.

- Conventions**
- Note** : Explanation of (Note) in the text
 - Caution** : Item deserving extra attention
 - Remark** : Supplementary explanation to the text
 - Numeric notation** : Binary . . . xxxx or xxxB
 Decimal . . . xxxx
 Hexadecimal . . . xxxxH or 0x xxxx
 - Prefixes representing powers of 2 (address space, memory capacity)
 - K (kilo): $2^{10} = 1024$
 - M (mega): $2^{20} = 1024^2 = 1,048,576$
 - G (giga): $2^{30} = 1024^3 = 1,073,741,824$

Terminology The meanings of terms used in this manual are listed below.

Emulator	Combination of RTE-1000-TP-EE and IE-703177-NW-EM
Target device	Device that is emulated.
Target system	The system (user-built system) to be debugged. This includes the target program and user-configured hardware.

Related Documents The related documents indicated in this publication may include preliminary versions. However, preliminary versions are not marked as such.

- **Documents related to V850E/CG2**

Document Name	Document Number
V850E/CG2 CARGATE-F Hardware Preliminary User's Manual	U15325EE1V0UM00
V850E1 User's Manual-Architecture	U14559EJ
μPD703177 Data Sheet	Under preparation

- **Documents related to development tools (User's Manual)**

Product Name	Document Number
RTE-1000-TP-EE (In-Circuit Emulator)	User's Manual Rev. 1.00
KIT-NB85E-TP	User's Manual Rev. 2.40
IE-703177-NW-EM (In-Circuit Emulator Optional Board)	This manual

Table of Contents

Introduction.....	5
Chapter 1 Overview	13
1.1 Hardware Configuration	13
1.2 Features (When Connected to RTE-1000-TP-EE)	14
1.3 Function Specifications (When Connected to RTE-1000-TP-EE)	14
1.4 System Configuration	15
1.5 Contents in Carton.....	16
1.6 Connection between RTE-1000-TP-EE and IE-703177-NW-EM	17
Chapter 2 Name and Function of Components.....	19
2.1 Component Name and Function of IE-703177-NW-EM.....	19
2.2 Clock Setting	24
2.2.1 Clock Structure.....	24
2.2.2 Main clock setting.....	25
2.3 Operation Mode	26
2.3.1 When emulator is used as stand-alone unit	26
2.3.2 When emulator is connected to target system	26
Chapter 3 Factory Settings	27
Chapter 4 Cautions	29
4.1 Standby Release	29
4.2 N-Wire connection speed settings (JTAG)	29
4.3 Pin Functions	29
4.3.1 MODE0 to MODE2 pins	29
4.3.2 RESET input.....	29
4.3.3 Clock signals.....	29
4.3.4 Port pins	30
4.3.5 Bus interface pins	31
4.3.6 Power supply voltage V_{DD3x}	32
4.3.7 Clock supply voltage CV_{DD}	32
4.3.8 AV_{DD} , AV_{REF} , AV_{SS} pins	32
4.4 BPC register access (setting of programmable peripheral I/O area)	32
4.5 Emulation Memory.....	33
4.5.1 Emulation memory mapping.....	34
4.6 Emulated Function Blocks	34
4.7 Extension Probe.....	34
Chapter 5 Debugger Operation.....	35
5.1 IRAM initialisation for the EVA chip.....	35
5.2 Start-up for Green Hills Multi 2000.....	35
5.3 CargateEM.rc for setting rsz register after reset.....	36
Chapter 6 Limitations	37
6.1 Emulation Memory.....	37
6.2 In-circuit Emulator RTE-1000-TP-EE	37
6.3 Software Development Tools	37
6.3.1 Green Hills Multi 2000 Environment for V800.....	37
6.3.2 Midas	37
Appendix A Package Drawings	39
Appendix B Example of Use of Connector for Target Connection.....	47

Appendix C Connectors for Target Connection..... 49
Appendix D Mounting of Plastic Spacer..... 53
Appendix E Revision History..... 55

List of Figures

Figure 1-1:	Hardware Configuration	13
Figure 1-2:	System Configuration	15
Figure 1-3:	Contents in Carton	16
Figure 1-4:	Connection between RTE-1000-TP-EE and IE-703177-NW-EM	17
Figure 2-1:	IE-703177-NW-EM (1/2).....	19
Figure 2-2:	Clock Structure	24
Figure 4-1:	Configuration of Ports PDH, PCS, PCT, PCD and PCM	30
Figure 4-2:	Configuration of Emulation Memory	33
Figure 5-1:	Sample .rc file for Green Hills Multi 2000	35
Figure A-1:	IE-703177-NW-EM (Unit: mm)	39
Figure A-2:	RTE-1000-TP-EE (Unit: mm).....	40
Figure A-3:	SWEX-144SD-1 (Unit: mm).....	41
Figure A-4:	NQPACK144SD (Unit: mm)	42
Figure A-5:	YQPACK144SD (Unit: mm).....	43
Figure A-6:	HQPACK144SD (Unit: mm)	44
Figure A-7:	YQSOCKET144DN (Unit: mm).....	45
Figure B-1:	When directly connecting device to target system (Connector for target connection is not used)	47
Figure B-2:	When equipping device by using connector for target connection	47
Figure B-3:	Connection between emulator and target system	48
Figure C-1:	Mounting of NQPACK144SD	49
Figure C-2:	Mounting Device.....	50
Figure C-3:	NQPACK144SD and Device Pin	50
Figure D-1:	Mounting Method of Plastic Spacer.....	53

List of Tables

Table 1-1:	Dimensions of the IE-703177-NW-EM	14
Table 1-2:	Function Specifications.....	14
Table 2-1:	Test pins	20
Table 2-2:	Connector List	21
Table 2-3:	Sockets.....	22
Table 2-4:	Switches	22
Table 2-5:	LEDs.....	22
Table 2-6:	Jumper List.....	23
Table 2-7:	Hardware Configuration for Main Clock Supply.....	25
Table 3-1:	Factory Settings.....	27
Table 4-1:	Functions Emulated by Other Hardware than Real-chip	34

Chapter 1 Overview

The IE-703177-NW-EM is an optional board for an in-circuit emulator as RTE-1000-TP-EE. By connecting the IE-703177-NW-EM to RTE-1000-TP-EE, hardware and software can be debugged efficiently in system development using the V850E/CG2 CARGATE-F.

In this manual, the basic setup sequences and switch settings of the IE-703177-NW-EM when connecting it to the RTE-1000-TP-EE are described. For the names and functions of the parts of the RTE-1000-TP-EE, and for the connection of elements, refer to the RTE-1000-TP-EE **User's Manual** which is a separate volume.

1.1 Hardware Configuration

Figure 1-1: Hardware Configuration

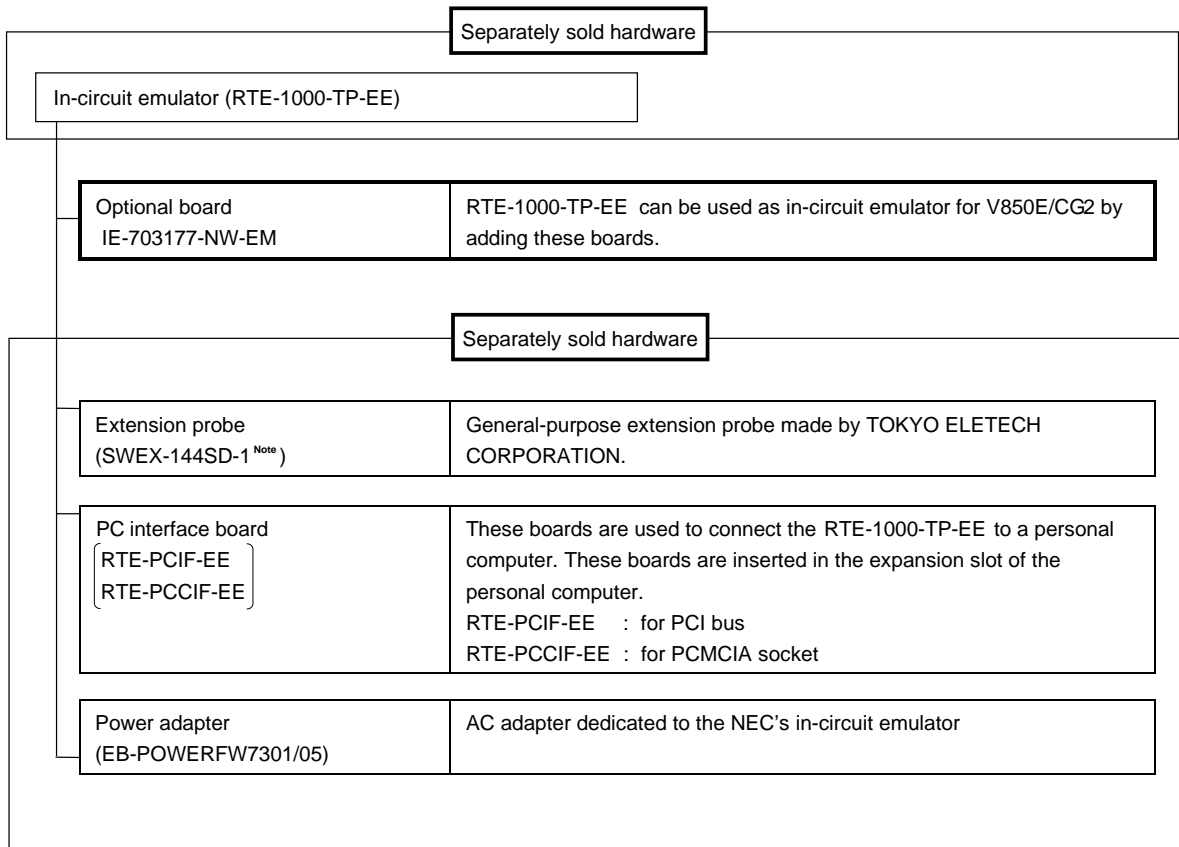

Note: For further information, contact Daimaru Kogyo Co., Ltd.
Tokyo Electronic Components Division (TEL +81-3-3820-7112)
Osaka Electronic Components Division (TEL +81-6-244-6672)

1.2 Features (When Connected to RTE-1000-TP-EE)

- Maximum operation frequency: 40 MHz
- Maximum operating frequency of the oscillator: 4 - 6 MHz
- Extremely lightweight and compact
- Higher equivalence with target device can be achieved by omitting buffer between signal cables.
- Following pins can be masked: $\overline{\text{RESET}}$, NMI, INTP0-INTP9
- Following internal signals can be masked: NMI1(FPU), INT0-INT50
- Two methods of connection to target system:
 - Direct connection of the IE-703177-NW-EM
 - Attach an extension probe (sold separately) to the connection tab of the IE-703177-NW-EM.
- Dimensions of the IE-703177-NW-EM are as follows.

Table 1-1: Dimensions of the IE-703177-NW-EM

Parameter		Value
Power dissipation		4.0 W (at 40-MHz operation frequency)
External dimensions (Refer to APPENDIX A DIMENSIONS)	Height	35 mm
	Length	140 mm
	Width	140 mm
Weight		300 g

1.3 Function Specifications (When Connected to RTE-1000-TP-EE)

Table 1-2: Function Specifications

Parameter		Specification
Emulation memory capacity	Internal ROM	None
	On board emulation memory	32 bit width: 16 Mbytes (mounted on board in two banks: 8 MB + 8 MB) 16 bit width: 8 Mbytes (mounted on board in two banks: 4 MB + 4 MB)

1.4 System Configuration

The system configuration when connecting the IE-703177-NW-EM to the RTE-1000-TP-EE, which is then connected to a personal computer (PC/AT compatible) is shown below.

Figure 1-2: System Configuration

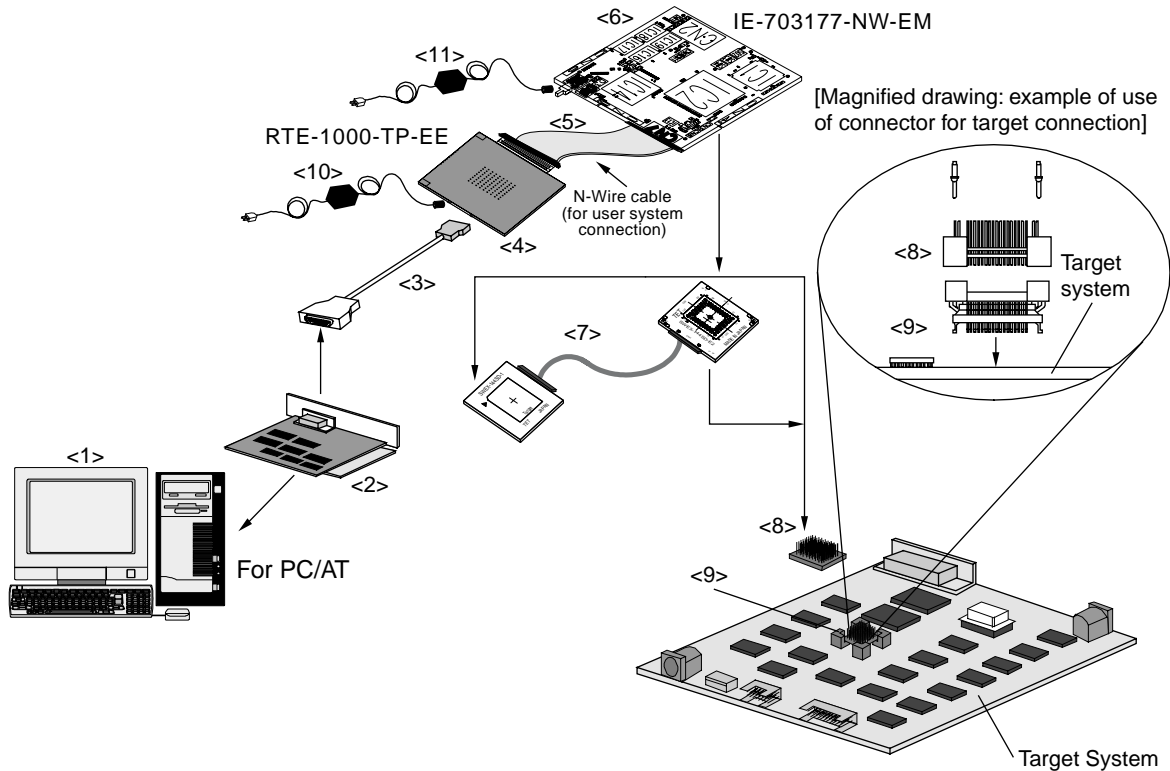

Remark

- <1> Personal computer
- <2> PC interface board (RTE-PCIF-EE, RTE-PCCIF-EE: sold separately)
- <3> PC interface cable (included with RTE-PCIF-EE or RTE-PCCIF-EE)
- <4> In-circuit emulator (RTE-1000-TP-EE: sold separately)
- <5> N-Wire cable (included with RTE-1000-TP-EE)
- <6> In-circuit emulator option board (IE-703177-NW-EM)
- <7> Extension probe (SWEX-144SD-1: sold separately)
- <8> Connector for emulator connection (YQPACK144SD: included)
- <9> Connector for target connection (NQPACK144SD: included)
- <10> Power adapter for RTE-1000-TP-EE (EB-POWERFW7301/05: sold separately)
- <11> Power adapter for IE-703177-NW-EM (EB-POWERFW7301/05: sold separately)

1.5 Contents in Carton

The carton of the IE-703177-NW-EM contains a main unit, Registration Card and a Readme (includes detailed documentation packing list). In case of missing or damaged contents, contact an NEC sales representative or an NEC distributor.

Figure 1-3: Contents in Carton

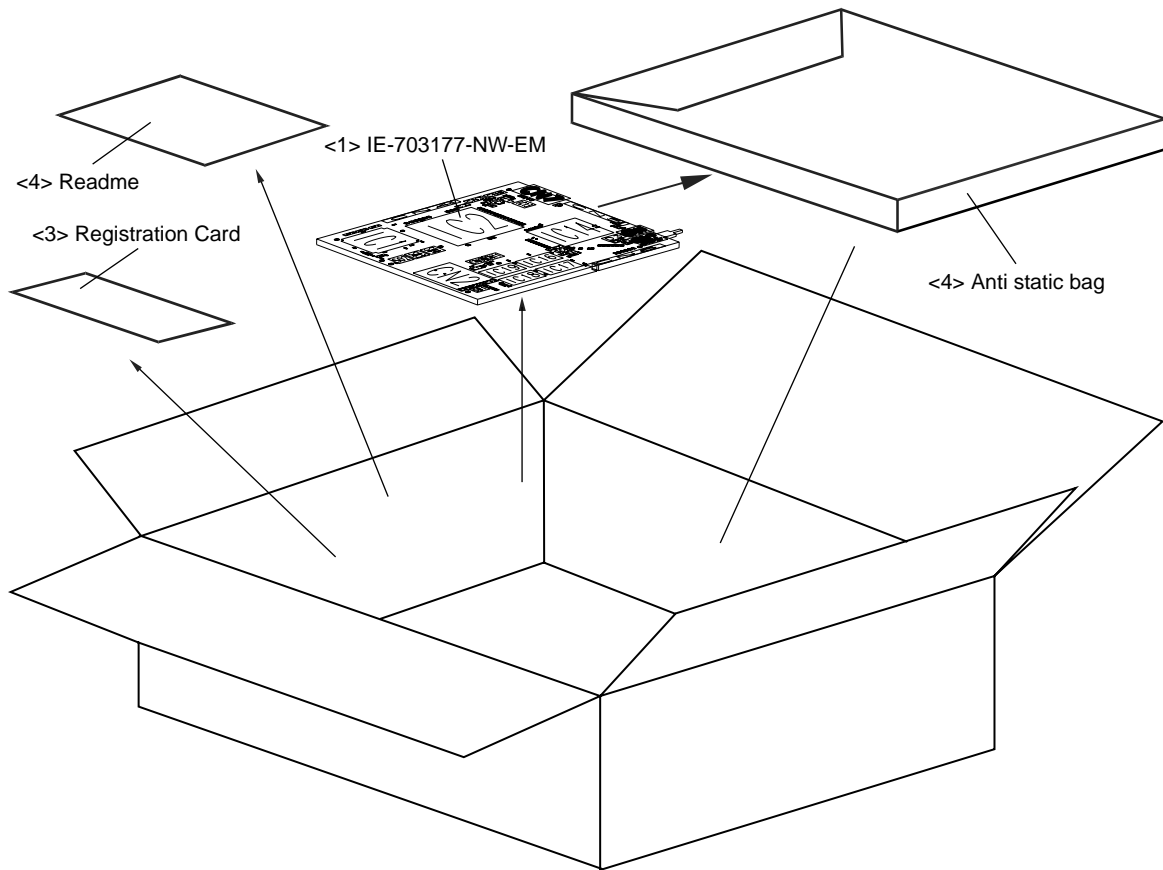

- <1> IE-703177-NW-EM × 1 (inside Anti static bag)
- <2> Readme (includes detailed packing list, with all attached documents listed in detail) × 1
- <3> Registration card × 1
- <4> Anti static bag × 1

1.6 Connection between RTE-1000-TP-EE and IE-703177-NW-EM

The procedure for connecting the RTE-1000-TP-EE and IE-703177-NW-EM is described below.

<1> Connect the RTE-1000-TP-EE to the CN7 of the IE-703177-NW-EM (refer to Figure 1-4).

Figure 1-4: Connection between RTE-1000-TP-EE and IE-703177-NW-EM

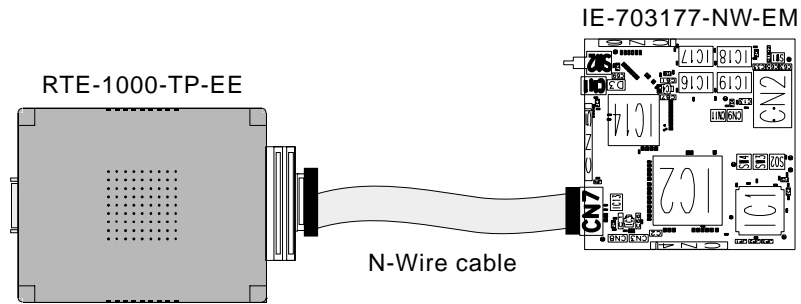

[MEMO]

Chapter 2 Name and Function of Components

(2) Connector List

Table 2-2: Connector List

Connector	Function
CN1	5 V board power supply
CN2,CN3,CN4,CN5,CN6,CN8,CN10	Reserved
CN7	N-Wire connector to RTE-1000-TP-EE
CN9	Emulation Board Mode setting
CN11	Emulation Memory mapping

Jumper on Connector	Function	Close	Open
CN11 1-2	$\overline{CS0}$ mapped	Emulation Memory Bank0 selected	Target
CN11 3-4	$\overline{CS1}$ mapped	Emulation Memory Bank1 selected	Target
CN11 5-6	$\overline{CS2}$ mapped	Emulation Memory Bank1 selected	Target
CN11 7-8	$\overline{CS3}$ mapped	Emulation Memory Bank1 selected	Target
CN11 9-10	$\overline{CS4}$ mapped	Emulation Memory Bank1 selected	Target
CN11 11-12	$\overline{CS6}$ mapped	Emulation Memory Bank1 selected	Target
CN11 13-14	Reserved	Reserved	Reserved
CN11 15-16	Reserved	Reserved	Reserved

Jumper on Connector	Function	Close	Open
CN9 1-2	Emulation Mode setting	Stand-alone	Target
CN9 3-4	Emulation RAM mapping (only required in stand-alone mode)	Memory Interface configured 16-bit width	Memory Interface configured 32-bit width
CN9 5-6	Reserved	Reserved	Reserved
CN9 7-8	Reserved	Reserved	Reserved
CN9 9-10	Reserved	Reserved	Reserved
CN9 11-12	Reserved	Reserved	Reserved
CN9 13-14	Reserved	Reserved	Reserved
CN9 15-16	Reserved	Reserved	Reserved

(3) Sockets

Table 2-3: Sockets

Socket	Function
SO1	Socket for target connection (optional via probe cable)
SO2	Socket of crystal oscillator module for main clock supply (4 to 6 MHz)

(4) Switches/Buttons

Table 2-4: Switches

Socket	Function
SW2	5 V board power supply off/on
SW3	Reserved (Main clock supply factory setting)
SW4	Reserved
SW1	Reset (Only on EM board, not for target hardware) The SW1 could be masked

(5) LEDs

Table 2-5: LEDs

LED	Function
D4 (yellow)	Indicates detection of valid target mode selection
D5 (yellow)	Indicates detection of valid target power (3.3 V, $C_{V_{DD}}$ and GND)
D9 (red)	Indicates board power supplied 5.0 V
D7 (yellow)	Indicates $\overline{\text{RESET}}$ active
D8 (green)	Indicates 3.3 V target power on
D6 (yellow)	Indicates program execution. on: Program is executed off: Program is halted

(6) Jumpers

Table 2-6: Jumper List

Jumper	Function	1-2	2-3
JP1	AV _{REF}	Internal 3.3 V	Target
JP2	AV _{DD}	Internal 3.3 V	Target
JP3	AV _{SS}	Internal GND	Target

Jumper	Function	Open	Closed
JP4	N-Wire power detection	Normal operation	Reserved

2.2 Clock Setting

2.2.1 Clock Structure

The main clock supply of IE-703177-NW-EM can be provided by an internal crystal oscillator (plugged on SO2). By default the IE-703177-NW-EM is equipped with a crystal oscillator on socket SO2 (5.000 MHz / 3.3 V).

Using a clock source from target hardware is not possible.

Figure 2-2: Clock Structure

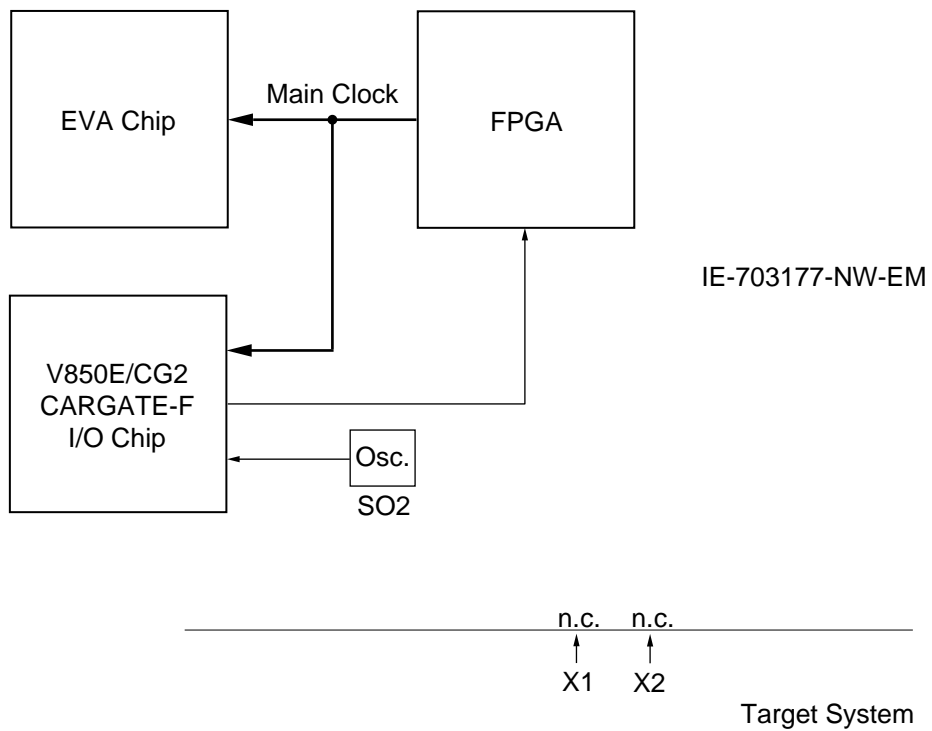

2.2.2 Main clock setting

The following clock setting methods are available for main clock supply.

- (1) Use the crystal oscillator mounted on SO2 of the IE-703177-NW-EM as internal clock (5.000 MHz).
- (2) Change the crystal oscillator mounted on SO2 of the IE-703177-NW-EM and use it as the internal clock (permitted from 4.000 MHz to 6.000 MHz).

Caution: When using an different crystal oscillator, use a 3.3 V type.

Table 2-7: Hardware Configuration for Main Clock Supply

Type of Clock	SO2 Crystal/Ceramic Resonator	SW3	SW4
(1) Crystal oscillator mounted on SO2 as internal clock	Factory setting (5.000 MHz)	Reserved (default factory setting)	Reserved (default factory setting)
(2) Customer specific crystal oscillator mounted on SO2 as the internal clock	Customer specific (4.000 to 6.000 MHz)	Reserved (default factory setting)	Reserved (default factory setting)

2.3 Operation Mode

The IE-703177-NW-EM supports only the ROMless mode, the same as the V850E/CG2 CARGATE-F. For this the following mode setting has to be configured.

2.3.1 When emulator is used as stand-alone unit

When using a debugger, be sure to set Jumper on CN9 1-2 for standalone mode. During this stand-alone mode, the

- (1) target mode pins are masked and are not evaluated. The LED D4 is switched on.
- (2) target \overline{CSx} pins are masked and are driving High level on default.
- (3) target \overline{RESET} pin is masked.

The mode pins on target interface are monitored only. For checking target mode setting, check that D4 LED is on (on == mode correct).

2.3.2 When emulator is connected to target system

When using a debugger, be sure to remove Jumper on CN9 1-2 for target mode. During this mode, the





- (1) on board \overline{RESET} will stay active, until target power is switched on.
- (2) on board \overline{RESET} becomes active, when target power will be switched off.

The emulation mode will be set by the target mode pins MODE0, MODE1 and MODE2. For checking target mode setting, check that D4 LED is on (on == valid correct).

For settings of the mode pins refer to the V850E/CG2 CARGATE-F **Hardware User's Manual**.

Chapter 3 Factory Settings

Table 3-1: Factory Settings

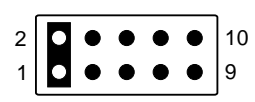
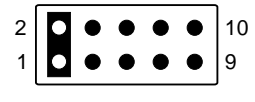
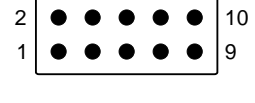
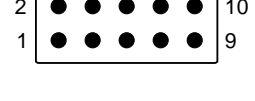
Item	Setting	Remark
JP1		Use internal 5 V for AV _{REF} by default.
JP2		Use internal 5 V for AV _{DD} by default.
JP3		Use internal GND for AV _{SS} by default.
JP4		Reserved (N-Wire power detection)
CN11		Emulation RAM mapping Emulation Memory Bank0 selected by default. $\overline{CS0}$ mapped internal
CN9		Emulation Board Mode setting Standalone selected by default Memory Interface configured 32-bit width by default
CN3		Reserved
CN8		Reserved
SO2	5.000-MHz crystal oscillator is mounted.	The main clock frequency can be changed by changing the crystal oscillator (4.000 MHz to 6.000 MHz)
SW3	Initial position	Reserved (Main clock supply factory setting)
SW4	Initial position	Reserved

[MEMO]

Chapter 4 Cautions

4.1 Standby Release

In emulation mode the main clock oscillator is always running. Therefore, no oscillation stabilization time is required when stop mode is released. As a consequence the emulator will wake up immediately from stop mode while the target device always assures the oscillation stabilization time for main oscillator.

4.2 N-Wire connection speed settings (JTAG)

The emulation board supports the following speed setting for the N-Wire interface to the RTE-1000-TP-EE:

- > 4.5 MHz Oscillator on SO2 used: 25 MHz JTAG clock (env jtag25)
- < 4.5 MHz Oscillator on SO2 used: 12 MHz JTAG clock (env jtag12)

This setting must be done in the .rc-file (refer to Figure 5-1, "Sample .rc file for Green Hills Multi 2000," on page 35) or in the target window of the debugger environment.

4.3 Pin Functions

4.3.1 MODE0 to MODE2 pins

The operation mode of the emulator is ROM-less mode only. When the emulator operates as a stand-alone unit, the MODE0 to MODE2 pins are not evaluated. When the emulator operates in target-mode, the MODE0 to MODE2 pins are valid.

The MODE0 to MODE2 pins are connected as follows.

- MODE0: Connected to target connector
- MODE1: Connected to target connector
- MODE2: Connected to target connector

The MODE0 to MODE2 are connected to the FPGA. Therefore the behavior differs from the target device.

4.3.2 $\overline{\text{RESET}}$ input

The $\overline{\text{RESET}}$ input pin is connected to V_{DD} via a resistor (10 K Ω pull-up to +3,3V). Therefore the behavior differs from the target device.

4.3.3 Clock signals

(1) X1, X2 signal

The input signals from the target system are not connected. Therefore the input characteristics may differ from the target device.

4.3.4 Port pins

The ports PDH, PCS, PCT, PCD and PCM, which are shared with the memory bus interface function, are not emulated by the I/O chip, but by the FPGA chip (refer to Figure 4-2, “Configuration of Emulation Memory,” on page 33).

Driving capabilities are different compared to the target device.

- FPGA: 12 mA
- Target device: 3 mA

Figure 4-1: Configuration of Ports PDH, PCS, PCT, PCD and PCM

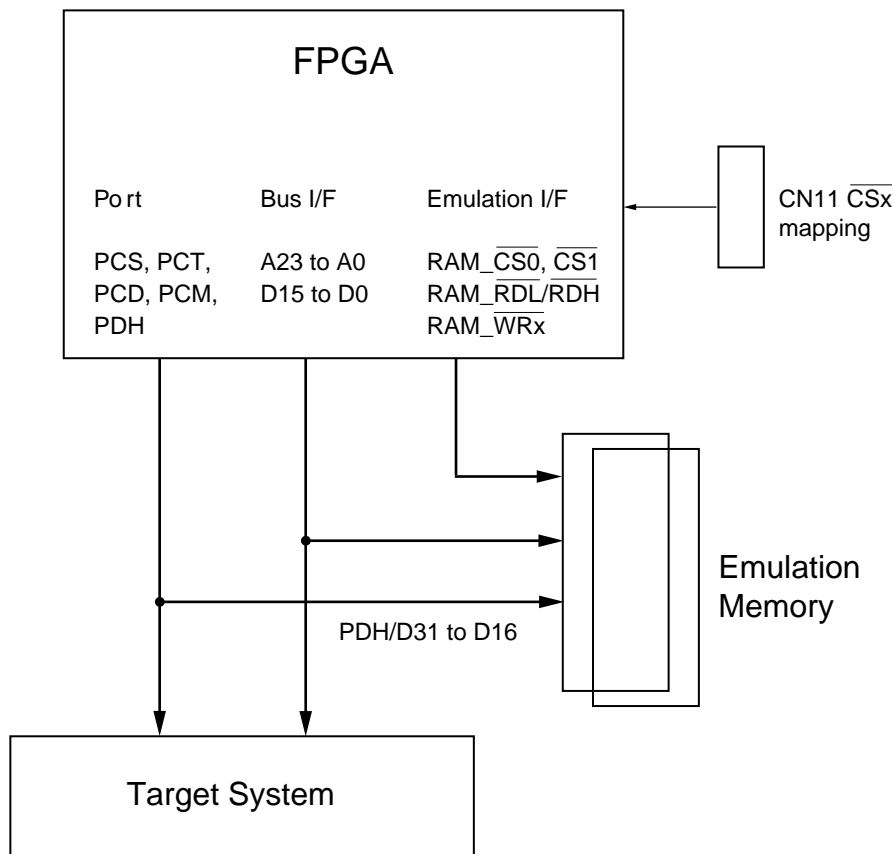

Emulation memory is connected to the lines of A23 to A0, D31 to D16 / PDH and D15 to D0. This produces additional load. Additionally a 33 Ω serial resistor is designed into each Bus I/F line. The control signals of the emulation memory are supplied from the FPGA and are not shared with the PCS, PCT, PCD and PCM pins.

4.3.5 Bus interface pins

(1) Address lines A23 to A0

Since emulation memory is connected to the address line A23 to A0, additional load has to be considered for the target system. Driving capabilities are different compared to the target device.

- Emulator: 12 mA
- Target device: 3 mA

(2) Data lines D15 to D0

Since emulation memory is connected to the data line D15 to D0, additional load has to be considered for the target system. Driving capabilities are different compared to the target device.

- Emulator: 12 mA
- Target device: 3 mA

(3) Data lines D31 to D16 / PDH

Since emulation memory is connected to the data line D31 to D16, additional load has to be considered for the target system. Driving capabilities are different compared to the target device.

- Emulator: 12 mA
- Target device: 3 mA

(4) Control lines \overline{RD} , \overline{WR} , $\overline{WR0}$, $\overline{WR1}$, $\overline{BEN3}$ to $\overline{BEN0}$

Driving capabilities are different compared to the target device.

- Emulator: 12 mA
- Target device: 3 mA

(5) Chip select lines $\overline{CS0}$, $\overline{CS1}$, $\overline{CS2}$, $\overline{CS3}$, $\overline{CS4}$, $\overline{CS6}$

All \overline{CSn} signals can be used for selecting emulation memory or memory on a target system ($n = 0, 1, 2, 3, 4, 6$).

The definition is done by the emulation memory configuration, selectable via CN11 Table 2-2, "Connector List," on page 21.

As soon as an emulation memory block is assigned to a \overline{CSn} signal, the signal is reserved for emulation memory and is not usable by a target system any more. In that case the target system will see a high-level (3.3 V) on that line. Driving capabilities are different compared to the target device.

- Emulator when \overline{CSn} used for target system: 12 mA
- Target device: 3 mA

(6) \overline{WAIT} input

The \overline{WAIT} input is held to high-level (+3.3 V) via a 10 K Ω pull-up resistor. For the emulator working in stand-alone mode (set by CN9 Table 2-2, "Connector List," on page 21) this is required. This is different compared to the target device.

4.3.6 Power supply voltage V_{DD3x}

The emulator is supplied by its own power supply. Therefore the target voltage input at the target probe is only used as a sensing input, and the resulting power consumption may be less as it would be for the target device.

Nevertheless, when a target hardware is to be used (non stand-alone operation), the emulator needs to be connected to all power supply lines V_{DD3x} as well as V_{SS3x} .

4.3.7 Clock supply voltage CV_{DD}

The clock supply voltage input CV_{DD} behaves the same as the V_{DD3x} lines (refer to 4.3.6 Power supply voltage V_{DD3x}).

Nevertheless, when a target hardware is to be used (non stand-alone operation), the emulator needs to be connected to the clock supply lines CV_{DD} and CV_{SS} .

4.3.8 AV_{DD} , AV_{REF} , AV_{SS} pins

Power supply of to these pins can be connected to the internally 3.3 V power supply by jumpers JP1, JP2, and JP3 (factory setting). In that case resulting A/D converter values and load on AV_{DD} , AV_{REF} , AV_{SS} pins may differ.

4.4 BPC register access (setting of programmable peripheral I/O area)

In emulation mode, the read access to the BPC register differs, out of the tow masked bits 12 and 13. During program execution there is no difference and there is no influence of the function. Recommended setting for CARGATE-F is 8F81h. The read value is BF81h, where bit 12 and 13 must be ignored.

4.5 Emulation Memory

Figure 4-2: Configuration of Emulation Memory

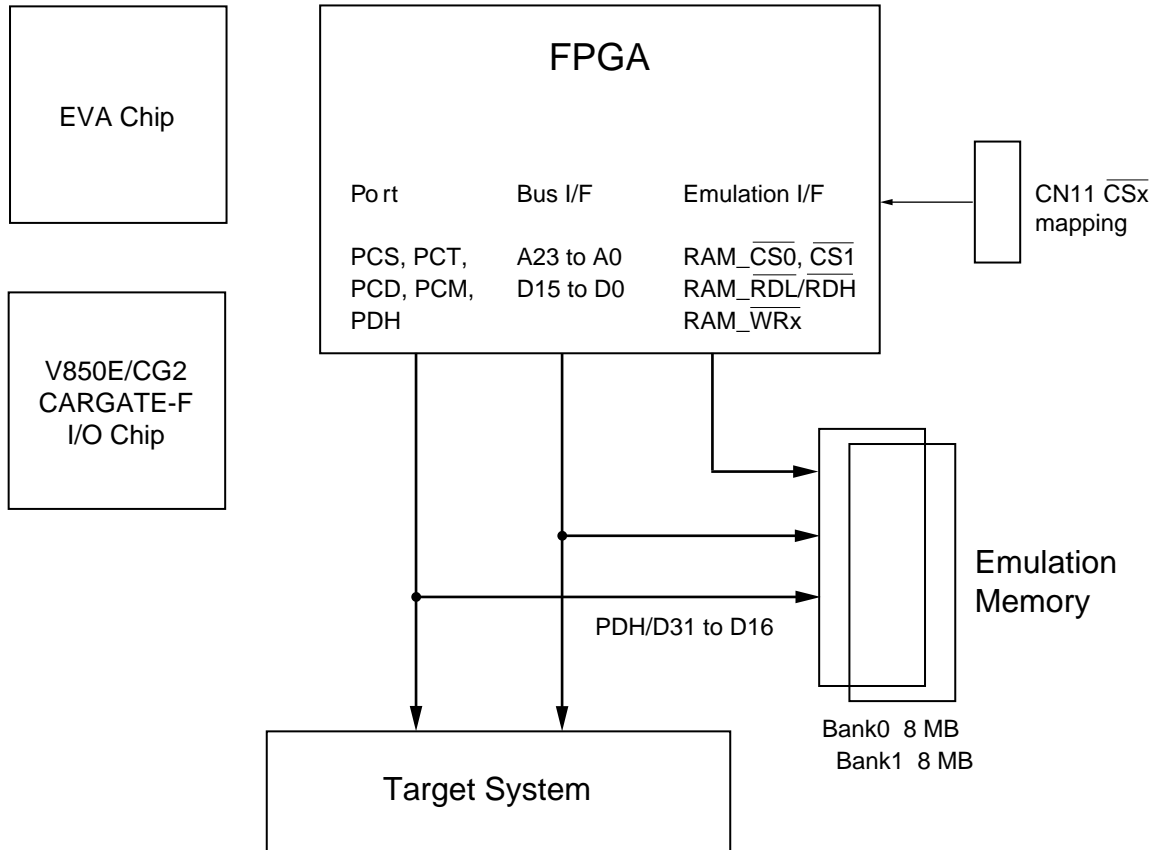

The emulation memory must be configured before downloading a program. For this the CN11 is provided to setup this via FPGA. The emulation memory can be configured to be used as 32-bit or 16-bit memory. In 16-bit mode, only half the size is available. The mode setting determines the width. Both banks are configured to the same data width.

Emulation memory is split into two banks of 8 MByte each: bank0 and bank1 ($2M \times 32$ or $2M \times 16$). Bank0 can be mapped to CS0 or it can be disabled. Bank1 could be mapped on any of the chip-select signals CS1, CS2, CS3, CS4 or CS6, or it can be disabled.

The banks can be accessed in 32-bit or 16-bit mode. In standalone mode, this will be done via jumper setting on CN9 (refer to Table 2-2, "Connector List," on page 21). In target mode this will be done by the evaluation of MODE0 to MODE2 pins.

Emulation memory can be accessed with no wait states.

The data lines D32 to D16 can either be used as data lines or as port pins PDH. The ports are available only in 16-bit memory mode.

Caution: If the ports PCS, PCT, PCD and PCM are used in port mode, the emulation memory could still be used. This is different compared to the target device.

4.5.1 Emulation memory mapping

Bank0 can be mapped to $\overline{CS0}$, bank1 can be mapped to \overline{CSn} (n = 1, 2, 3, 4 or 6). This will be done via jumper setting on CN11 (refer to Table 2-2, “Connector List,” on page 21).

Emulation memory can be accessed with zero data wait state, which is specified in the data wait control register DWC0 or DWC1.

The data lines D31 to D16 / PDH can either be used as address lines or as port pins, depending on the bus size required. The data lines D31 to D16 must be configured by the mode pins in user mode and via jumper setting on CN9 (refer to Table 2-2, “Connector List,” on page 21) in standalone mode.

4.6 Emulated Function Blocks

The IE-703177-NW-EM emulator option board is based on a target device, the V850E/CG2 CARGATE-F I/O chip. The following table shows the functions, which are not or not complete emulated by the I/O chip itself. For these functions a deviation between target device and emulator behavior might be possible.

Table 4-1: Functions Emulated by Other Hardware than Real-chip

Emulation	Function
FPGA	External memory interface / Ports (A23 to A0, D31 to D15 / PDH, D15 to D0, PCS, PCT, PCM, PCD)
Eva Chip D703193	CPU
Eva Chip D703193	IRAM
Eva Chip D703193	iCache
Eva Chip D703193	INTC (Interrupt controller)
Eva Chip D703193	DMA controller
Eva Chip D703193 / FPGA	Reset
Eva Chip D703193	Mode pins

4.7 Extension Probe

For best signal quality use the emulator without an extension probe if possible. When necessary use the SWEX-144SD extension probe. Do not use more than one extension probe in serial.

Chapter 5 Debugger Operation

5.1 IRAM initialisation for the EVA chip

The IRAM of the EVA chip must be setup after power on and after each reset. After power on and after reset, the IRAM is not available and therefore must be configured in the .rc-file, when using Green Hills Multi 2000, for re-configuration after reset.

If this initialisation has not been implemented, the program execution fails.

5.2 Start-up for Green Hills Multi 2000

A sample .rc-file for Multi 2000 is shown in Figure 5-1.

Figure 5-1: Sample .rc file for Green Hills Multi 2000

```
//
// CargateF_HW_Test.rc
//
// Start-up file for Cargate-F EM test program
// (C) Copyright by NEC Electronics (Europe) GmbH
//
// Revisions:
// 2002/11/28 ME Initial.
//
*****
remote rteserv;           // connect to target
target init;             // reset RTE ICE
target env jtag25;       // set up RTE ICE for main clock >4.5 MHz
//target env jtag12;     // set up RTE ICE for main clock <4.5 MHz
target env 64m romless d0 i2; // set up CPU (64 MB mode, no ROM, no dCache,
// 2-way iCache)
target sfrfile.\Src\D3177.800; // load SFR definitions from device file
target reset;           // reset CPU

<CargateEM.rc;          // set up iRAM size (60K mode, only 32K used)

target env !reset !nmi0 !nmil nmi2 hldrq stopz;
// unmask/mask target pins

// display opcodes in ASM view
eval $_OPCODE = 1;
eval $_ASMCACHE = 0;

// setup GUI
button Reset           {target reset; target sfr rsz 0x40;}
button ViewMemory memview 0x00000000;

// indicate success
echo " ";
echo "-----";
echo "Initialization done.";
echo " ";

// ***** EOF *****
```

5.3 CargateEM.rc for setting rsz register after reset.

```
//
// CargateEM.rc
//
// Macros for Cargate-EM configuration
// (C) Copyright by NEC Electronics (Europe) GmbH
//
// Usage:
// Just include (<CargateEM.rc) this file
//
// Revisions:
// 2003/02/20 ME Initial
//
//
*****

// This next section sets some SFRs to the device reset defaults as the
// reset values of the emulator differ.

define CargateEM_SFRFix() {
    // setup any other SFRs...
    target sfr rsz 0x40; // set up iRAM size (60k mode, only 32k used)
}
CargateEM_SFRFix(); // do it right away
b 0x00000000 { CargateEM_SFRFix(); c; } // and after every reset

// ***** EOF *****
```

Chapter 6 Limitations

6.1 Emulation Memory

Emulation memory size is limited to 16 MB.

Emulation memory must be selected by a \overline{CS}_n line ($n = 0, 1, 2, 3, 4, 6$). That \overline{CS}_n line cannot be used for the target application.

Additional memory can be connected as target memory.

6.2 In-circuit Emulator RTE-1000-TP-EE

The in-circuit emulator option board IE-703177-NW-EM should be operated only with an in-circuit emulator as RTE-1000-TP-EE.

6.3 Software Development Tools

For correct operation in conjunction with the instruction cache it is mandatory to use the latest version of the following files with the development/debugging tools.

6.3.1 Green Hills Multi 2000 Environment for V800

- Multi 2000 version 3.5.1 or higher (including actual rteserv.exe)

6.3.2 Midas

- RTE4win32 version 5.08 or higher **Note**

Note: License for RTE target server is required. This license could be ordered separately, if not available.

[MEMO]

Appendix A Package Drawings

Figure A-1: IE-703177-NW-EM (Unit: mm)

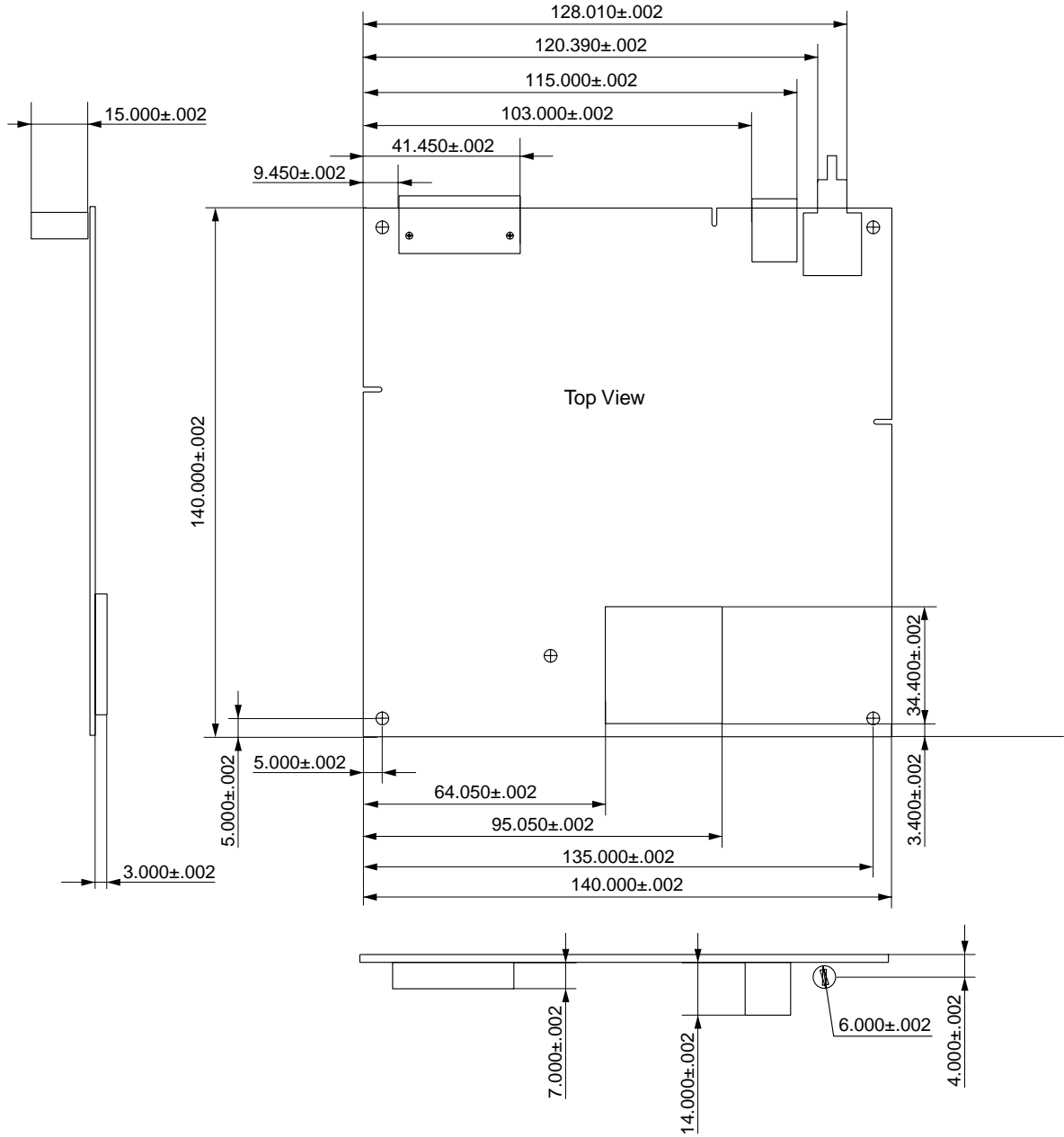

Appendix A Package Drawings

Figure A-2: RTE-1000-TP-EE (Unit: mm)

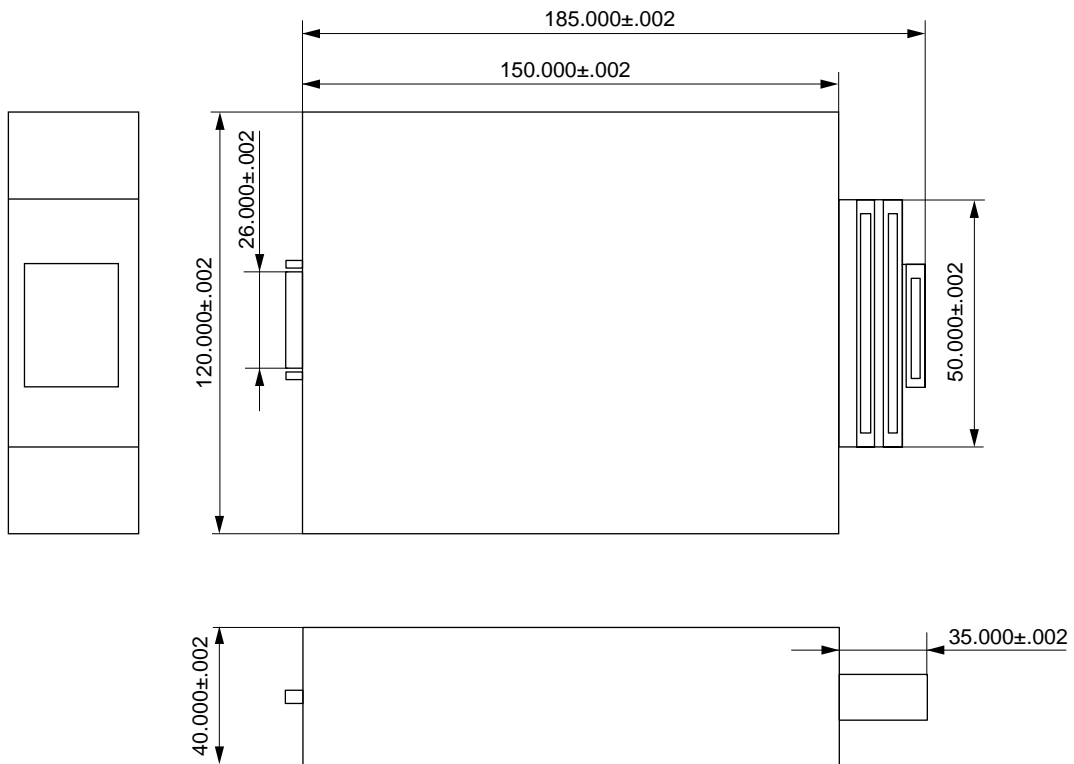

Appendix A Package Drawings

Figure A-6: HQPACK144SD (Unit: mm)

[Top view]

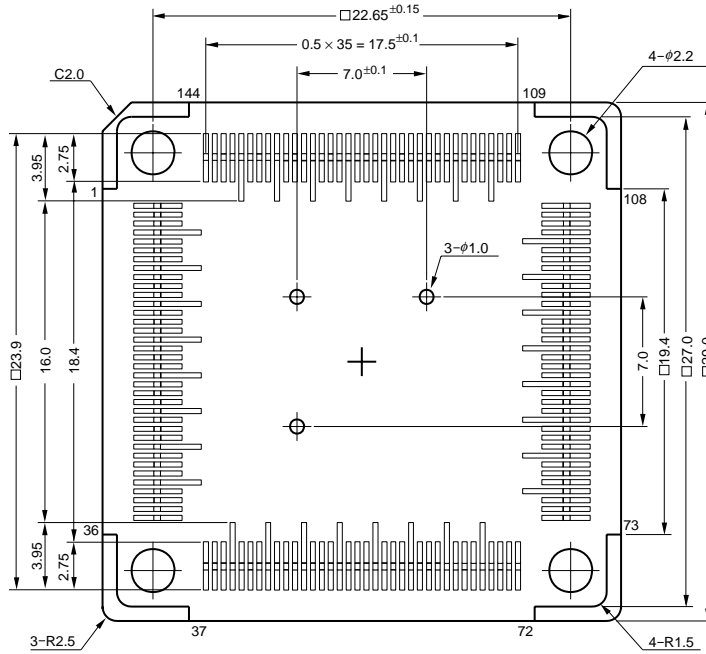

[Side view]

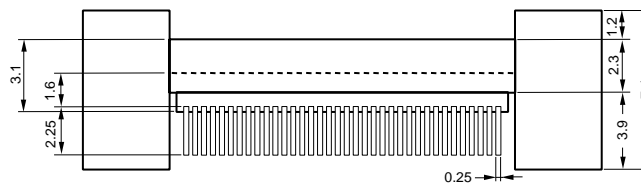

[Bottom view]

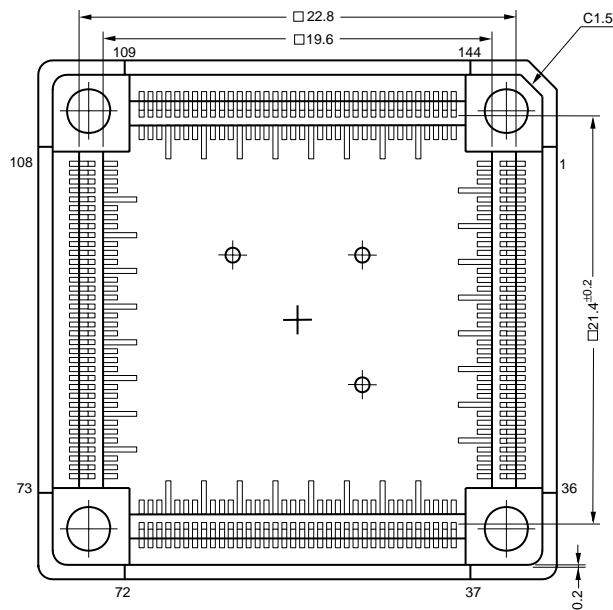
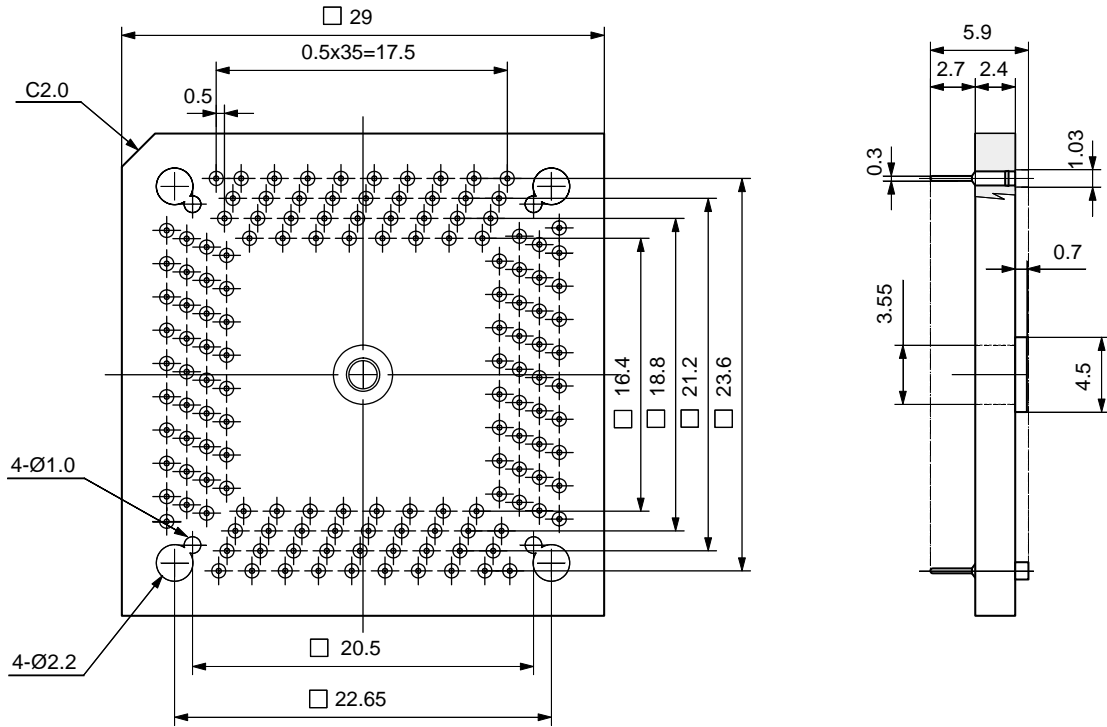

Figure A-7: YQSOCKET144DN (Unit: mm)



[MEMO]

Appendix B Example of Use of Connector for Target Connection

Figure B-1: When directly connecting device to target system
(Connector for target connection is not used)

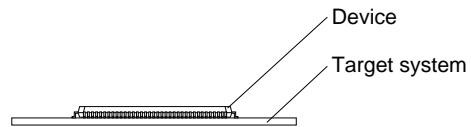

Figure B-2: When equipping device by using connector for target connection

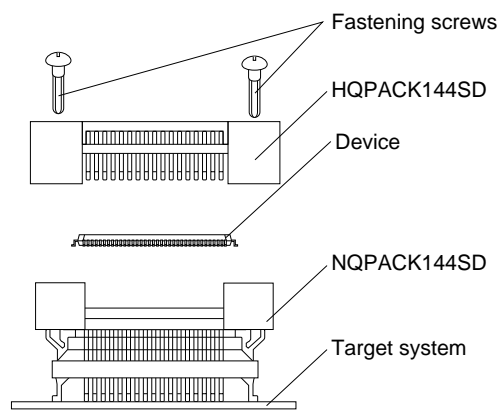
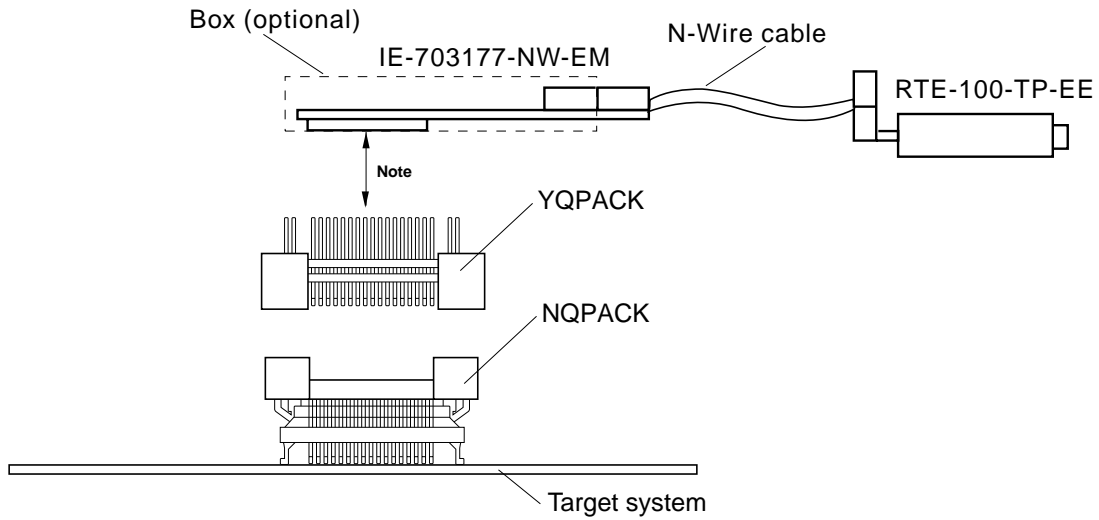

Figure B-3: Connection between emulator and target system

(a) When extension probe is not used



Note: Connector for emulator connection (YQSOCKET144SDN) can be inserted at this position for height adjustment.

(b) Example of use of extension probe

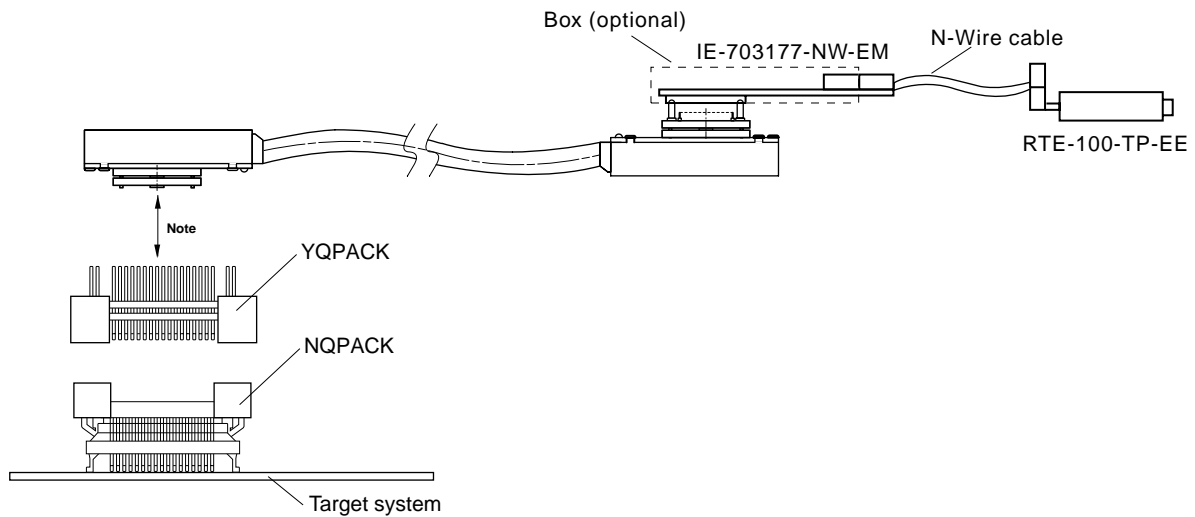

Note: Connector for emulator connection (YQSOCKET144SDN) can be inserted at this position for height adjustment.

Appendix C Connectors for Target Connection

C.1 Use

(1) When mounting NQPACK144SD to target system

<1> Coat the tip of four projections (points) at the bottom of the NQPACK144SD with two-component type epoxy adhesive (cure time longer than 30 min.) and bond the NQPACK144SD to the target system. If not bonded properly, the pad of the printed circuit board may peel off when the emulator is removed from the target system. If the lead of the NQPACK144SD does not coincide with the pad of the target system easily, perform step <2> to adjust the position.

<2> To adjust the position, insert the guide pins for position-adjustment (NQGUIDE) provided with NQPACK144SD into the pin holes at the upper side of NQPACK144SD (refer to **Figure C-1**). The diameter of a hole is $\phi = 1.0$ mm. There are three non-through holes (refer to **APPENDIX A DIMENSIONS**).

<3> After setting the HQPACK144SD, solder NQPACK144SD to the target system. By following this sequence, adherence of flux or solder spluttering to contact pins of the NQPACK144SD can be avoided.

- Recommended soldering condition...Reflow : 240°C, 20 sec. max.
Partial heating : 240°C, 10 sec. max. (per pin row)

<4> Remove the guide pins.

Figure C-1: Mounting of NQPACK144SD

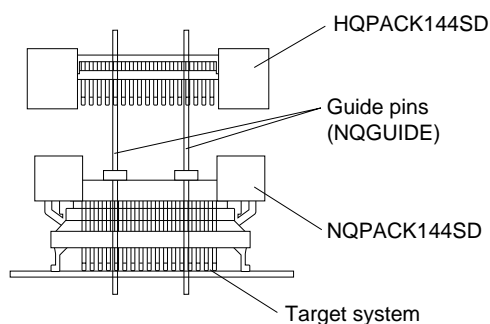

Remark: NQPACK144SD: Connector for target connection
HQPACK144SD: Cover for device installation

(2) When setting device

Caution: Check for abnormal conditions such as resin burr or bent pins before setting a device to the NQPACK144SD. Moreover, check that the hold pins of the HQPACK144SD are not broken or bent before setting HQPACK144SD. If there are broken or bent pins, fix them with a thin, flat plate such as a blade.

<1> Make sure that the NQPACK144SD is clean and the device pins are parallel (flat) before setting a device to the NQPACK144SD. Then, after mounting the NQPACK144SD to the target board, set the device and HQPACK144SD (refer to **Figure C-2**).

<2> Using the screws provided with the HQPACK144SD (four locations: M2 × 6 mm), secure the HQPACK144SD, device, and NQPACK144SD.

Tighten the screws in a crisscross pattern with the provided screwdriver or driver with torque gauge (avoid tightening strongly only one screw). Tighten the screws with 0.55 kg-f-cm (0.054 N-m) max. torque. Excessive tightening may diminish conductivity.

At this time, each pin is fixed inside the plastic wall dividers by the contact pin of the NQPACK144SD and the hold pin of the HQPACK144SD (refer to **Figure C-3**). Thus, pins cannot cause a short with pins of neighboring devices.

Figure C-2: Mounting Device

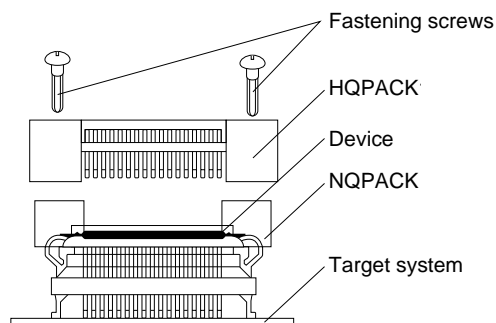
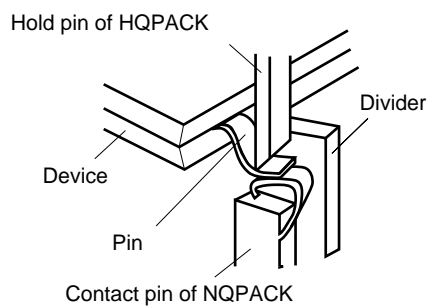

Figure C-3: NQPACK144SD and Device Pin



[MEMO]

Appendix D Mounting of Plastic Spacer

This chapter describes the mounting method for the plastic spacer supplied with the IE-V850E-MC-A. When using the emulator connected to the target system, mount the plastic spacer as shown in Figure D-1 to fix the pod horizontally.

(1) Mounting RTE-1000-TP-EE to plastic spacer

- <1> Remove the nylon rivet from the rear part of the pod.
- <2> Tighten the plastic spacer with the supplied plastic screw.
- <3> To adjust the height, use a user spacer or stand.

Figure D-1: Mounting Method of Plastic Spacer

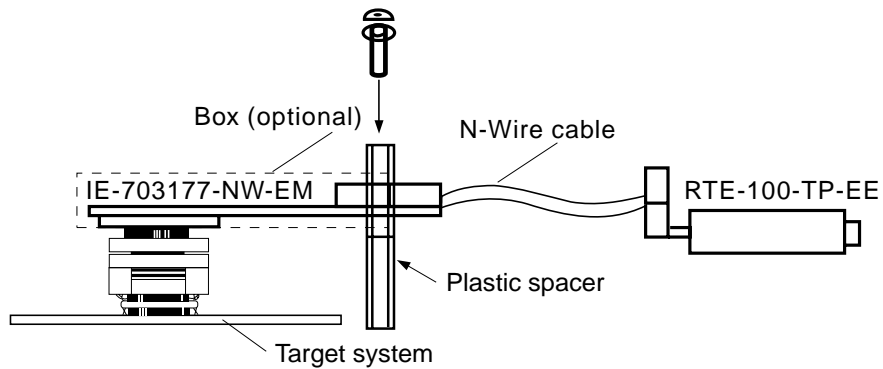

[MEMO]

Appendix E Revision History

Item	Date published	Document No.	Comment
1	February 2003	U16583EE1V0UM00	1 st Release
2			
3			
4			

[MEMO]

Facsimile Message

From:

Name

Company

Tel.

FAX

Address

Although NEC has taken all possible steps to ensure that the documentation supplied to our customers is complete, bug free and up-to-date, we readily accept that errors may occur. Despite all the care and precautions we've taken, you may encounter problems in the documentation. Please complete this form whenever you'd like to report errors or suggest improvements to us.

Thank you for your kind support.

North America

NEC Electronics Inc.
Corporate Communications Dept.
Fax: +1-800-729-9288
+1-408-588-6130

Hong Kong, Philippines, Oceania

NEC Electronics Hong Kong Ltd.
Fax: +852-2886-9022/9044

Asian Nations except Philippines

NEC Electronics Singapore Pte. Ltd.
Fax: +65-250-3583

Europe

NEC Electronics (Europe) GmbH
Market Communication Dept.
Fax: +49-211-6503-274

Korea

NEC Electronics Hong Kong Ltd.
Seoul Branch
Fax: +82-2-528-4411

Japan

NEC Semiconductor Technical Hotline
Fax: +81- 44-435-9608

South America

NEC do Brasil S.A.
Fax: +55-11-6462-6829

Taiwan

NEC Electronics Taiwan Ltd.
Fax: +886-2-2719-5951

I would like to report the following error/make the following suggestion:

Document title: _____

Document number: _____ Page number: _____

If possible, please fax the referenced page or drawing.

Document Rating	Excellent	Good	Acceptable	Poor
Clarity	<input type="checkbox"/>	<input type="checkbox"/>	<input type="checkbox"/>	<input type="checkbox"/>
Technical Accuracy	<input type="checkbox"/>	<input type="checkbox"/>	<input type="checkbox"/>	<input type="checkbox"/>
Organization	<input type="checkbox"/>	<input type="checkbox"/>	<input type="checkbox"/>	<input type="checkbox"/>

