

To our customers,

Old Company Name in Catalogs and Other Documents

On April 1st, 2010, NEC Electronics Corporation merged with Renesas Technology Corporation, and Renesas Electronics Corporation took over all the business of both companies. Therefore, although the old company name remains in this document, it is a valid Renesas Electronics document. We appreciate your understanding.

Renesas Electronics website: <http://www.renesas.com>

April 1st, 2010
Renesas Electronics Corporation

Issued by: Renesas Electronics Corporation (<http://www.renesas.com>)

Send any inquiries to <http://www.renesas.com/inquiry>.

Notice

1. All information included in this document is current as of the date this document is issued. Such information, however, is subject to change without any prior notice. Before purchasing or using any Renesas Electronics products listed herein, please confirm the latest product information with a Renesas Electronics sales office. Also, please pay regular and careful attention to additional and different information to be disclosed by Renesas Electronics such as that disclosed through our website.
2. Renesas Electronics does not assume any liability for infringement of patents, copyrights, or other intellectual property rights of third parties by or arising from the use of Renesas Electronics products or technical information described in this document. No license, express, implied or otherwise, is granted hereby under any patents, copyrights or other intellectual property rights of Renesas Electronics or others.
3. You should not alter, modify, copy, or otherwise misappropriate any Renesas Electronics product, whether in whole or in part.
4. Descriptions of circuits, software and other related information in this document are provided only to illustrate the operation of semiconductor products and application examples. You are fully responsible for the incorporation of these circuits, software, and information in the design of your equipment. Renesas Electronics assumes no responsibility for any losses incurred by you or third parties arising from the use of these circuits, software, or information.
5. When exporting the products or technology described in this document, you should comply with the applicable export control laws and regulations and follow the procedures required by such laws and regulations. You should not use Renesas Electronics products or the technology described in this document for any purpose relating to military applications or use by the military, including but not limited to the development of weapons of mass destruction. Renesas Electronics products and technology may not be used for or incorporated into any products or systems whose manufacture, use, or sale is prohibited under any applicable domestic or foreign laws or regulations.
6. Renesas Electronics has used reasonable care in preparing the information included in this document, but Renesas Electronics does not warrant that such information is error free. Renesas Electronics assumes no liability whatsoever for any damages incurred by you resulting from errors in or omissions from the information included herein.
7. Renesas Electronics products are classified according to the following three quality grades: “Standard”, “High Quality”, and “Specific”. The recommended applications for each Renesas Electronics product depends on the product’s quality grade, as indicated below. You must check the quality grade of each Renesas Electronics product before using it in a particular application. You may not use any Renesas Electronics product for any application categorized as “Specific” without the prior written consent of Renesas Electronics. Further, you may not use any Renesas Electronics product for any application for which it is not intended without the prior written consent of Renesas Electronics. Renesas Electronics shall not be in any way liable for any damages or losses incurred by you or third parties arising from the use of any Renesas Electronics product for an application categorized as “Specific” or for which the product is not intended where you have failed to obtain the prior written consent of Renesas Electronics. The quality grade of each Renesas Electronics product is “Standard” unless otherwise expressly specified in a Renesas Electronics data sheets or data books, etc.
 - “Standard”: Computers; office equipment; communications equipment; test and measurement equipment; audio and visual equipment; home electronic appliances; machine tools; personal electronic equipment; and industrial robots.
 - “High Quality”: Transportation equipment (automobiles, trains, ships, etc.); traffic control systems; anti-disaster systems; anti-crime systems; safety equipment; and medical equipment not specifically designed for life support.
 - “Specific”: Aircraft; aerospace equipment; submersible repeaters; nuclear reactor control systems; medical equipment or systems for life support (e.g. artificial life support devices or systems), surgical implantations, or healthcare intervention (e.g. excision, etc.), and any other applications or purposes that pose a direct threat to human life.
8. You should use the Renesas Electronics products described in this document within the range specified by Renesas Electronics, especially with respect to the maximum rating, operating supply voltage range, movement power voltage range, heat radiation characteristics, installation and other product characteristics. Renesas Electronics shall have no liability for malfunctions or damages arising out of the use of Renesas Electronics products beyond such specified ranges.
9. Although Renesas Electronics endeavors to improve the quality and reliability of its products, semiconductor products have specific characteristics such as the occurrence of failure at a certain rate and malfunctions under certain use conditions. Further, Renesas Electronics products are not subject to radiation resistance design. Please be sure to implement safety measures to guard them against the possibility of physical injury, and injury or damage caused by fire in the event of the failure of a Renesas Electronics product, such as safety design for hardware and software including but not limited to redundancy, fire control and malfunction prevention, appropriate treatment for aging degradation or any other appropriate measures. Because the evaluation of microcomputer software alone is very difficult, please evaluate the safety of the final products or system manufactured by you.
10. Please contact a Renesas Electronics sales office for details as to environmental matters such as the environmental compatibility of each Renesas Electronics product. Please use Renesas Electronics products in compliance with all applicable laws and regulations that regulate the inclusion or use of controlled substances, including without limitation, the EU RoHS Directive. Renesas Electronics assumes no liability for damages or losses occurring as a result of your noncompliance with applicable laws and regulations.
11. This document may not be reproduced or duplicated, in any form, in whole or in part, without prior written consent of Renesas Electronics.
12. Please contact a Renesas Electronics sales office if you have any questions regarding the information contained in this document or Renesas Electronics products, or if you have any other inquiries.

(Note 1) “Renesas Electronics” as used in this document means Renesas Electronics Corporation and also includes its majority-owned subsidiaries.

(Note 2) “Renesas Electronics product(s)” means any product developed or manufactured by or for Renesas Electronics.

**H8S/2276R, H8S/2276 Series TFP-100G
User System Interface Cable (HS2276ECN61H)
for E6000 Emulator
User's Manual**

Cautions

1. Renesas neither warrants nor grants licenses of any rights of Renesas's or any third party's patent, copyright, trademark, or other intellectual property rights for information contained in this document. Renesas bears no responsibility for problems that may arise with third party's rights, including intellectual property rights, in connection with use of the information contained in this document.
2. Products and product specifications may be subject to change without notice. Confirm that you have received the latest product standards or specifications before final design, purchase or use.
3. Renesas makes every attempt to ensure that its products are of high quality and reliability. However, contact Renesas's sales office before using the product in an application that demands especially high quality and reliability or where its failure or malfunction may directly threaten human life or cause risk of bodily injury, such as aerospace, aeronautics, nuclear power, combustion control, transportation, traffic, safety equipment or medical equipment for life support.
4. Design your application so that the product is used within the ranges guaranteed by Renesas particularly for maximum rating, operating supply voltage range, heat radiation characteristics, installation conditions and other characteristics. Renesas bears no responsibility for failure or damage when used beyond the guaranteed ranges. Even within the guaranteed ranges, consider normally foreseeable failure rates or failure modes in semiconductor devices and employ systemic measures such as fail-safes, so that the equipment incorporating Renesas product does not cause bodily injury, fire or other consequential damage due to operation of the Renesas product.
5. This product is not designed to be radiation resistant.
6. No one is permitted to reproduce or duplicate, in any form, the whole or part of this document without written approval from Renesas.
7. Contact Renesas's sales office for any questions regarding this document or Renesas semiconductor products.

Preface

Thank you for purchasing this user system interface cable (HS2276ECN61H) for the Renesas's original microcomputer H8S/2276R, H8S/2276 series.

The HS2276ECN61H is a user system interface cable that connects an H8S/2214 series E6000 emulator (HS2214EPI61H; hereinafter referred to as the emulator) through the expansion board to the IC socket for a TFP-100G package for the H8S/2276R, H8S/2276 series MCU (HS2276REIO61H, HS2276EIO61H) on the user system.

Contents

Section 1	Configuration.....	1
Section 2	Connection Procedures.....	3
2.1	Connecting User System Interface Cable to Expansion Board.....	3
2.2	Connecting User System Interface Cable to User System.....	5
2.2.1	Installing IC Socket.....	6
2.2.2	Soldering IC Socket.....	7
2.2.3	Inserting Cable Head.....	7
2.2.4	Fastening Cable Head.....	8
2.2.5	Fastening Cable Body.....	10
2.3	Recommended Dimensions for User System Mount Pad.....	11
2.4	Dimensions for User System Interface Cable Head.....	12
2.5	Resulting Dimensions after Connecting User System Interface Cable.....	13
Section 3	Installing the MCU to the User System.....	14
Section 4	Verifying Operation.....	16
Section 5	Notice.....	19

Section 1 Configuration

CAUTION

Use an NQPACK100SE socket (manufactured by Tokyo Eletech Corporation) for the TFP-100G package IC socket on the user system.

Figure 1 shows the configuration of the HS2276ECN61H user system interface cable for the TFP-100G package.

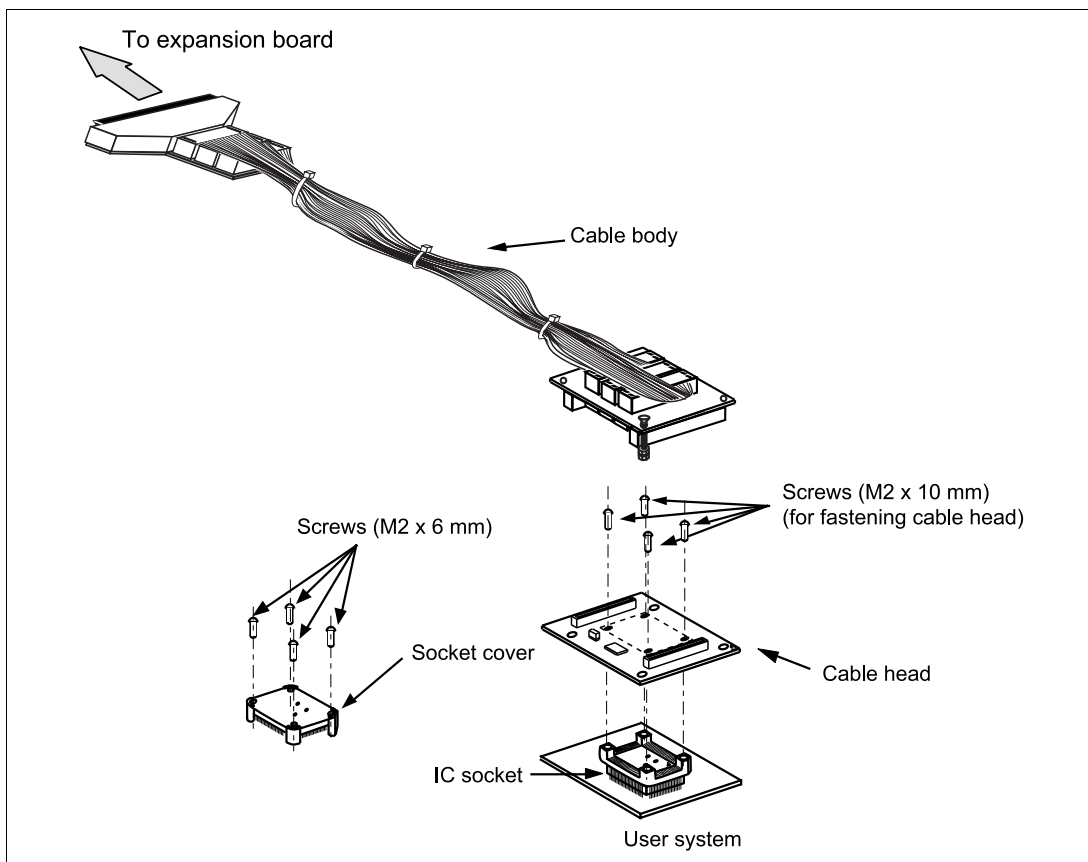

Figure 1 HS2276ECN61H User System Interface Cable

Table 1 lists the HS2276ECN61H components. Please make sure you have all of these components when unpacking.

Table 1 HS2276ECN61H Components

No.	Component	Quantity	Remarks
1	Cable body	1	Flat cable
2	Cable head	1	
3	IC socket	1	For the TFP-100G package
4	Socket cover	1	For installing a TFP-100G packaged MCU
5	Screws (M2.0 x 10 mm)	4	For fastening cable head
6	Screws (M2.0 x 6 mm)	4	For installing a TFP-100G packaged MCU
7	Guide pins (ϕ 1 mm)	3	For determining the IC socket location
8	Screwdriver	1	For tightening screws
9	Documentation	1	User's manual for HS2276ECN61H (this manual)

Section 2 Connection Procedures

2.1 Connecting User System Interface Cable to Expansion Board

WARNING

Observe the precautions listed below. Failure to do so will result in a FIRE HAZARD and will damage the user system and the emulator product or will result in PERSONAL INJURY. The USER PROGRAM will be LOST.

- 1. Always switch OFF the user system and the emulator product before the USER SYSTEM INTERFACE CABLE is connected to or removed from any part. Before connecting, make sure that pin 1 on both sides are correctly aligned.**
- 2. The user system interface cable dedicated to the emulator must be used.**

To connect the cable body to the emulator station, follow the instructions below.

1. Make sure the user system and emulator station are turned off.

CAUTION

When connecting or removing the user system interface cable, apply force only in the direction suitable for connection or removal, while making sure not to bend or twist the cable or connectors. Otherwise, the connectors will be damaged. The user system interface cable must be connected to an H8S/2214 Series E6000 emulator through the H8S/2276R, H8S/2276 Series expansion board. Do not connect the user system interface cable directly to the E6000 emulator.

2. [1] After making sure the direction of the expansion board connector labeled E6000 EMULATOR is correct, firmly insert the expansion board connector into the emulator station connector labeled USER INTERFACE ([1] in figure 2).
- [2] Connect the expansion board labeled USER INTERFACE CABLE and the user system interface cable body.

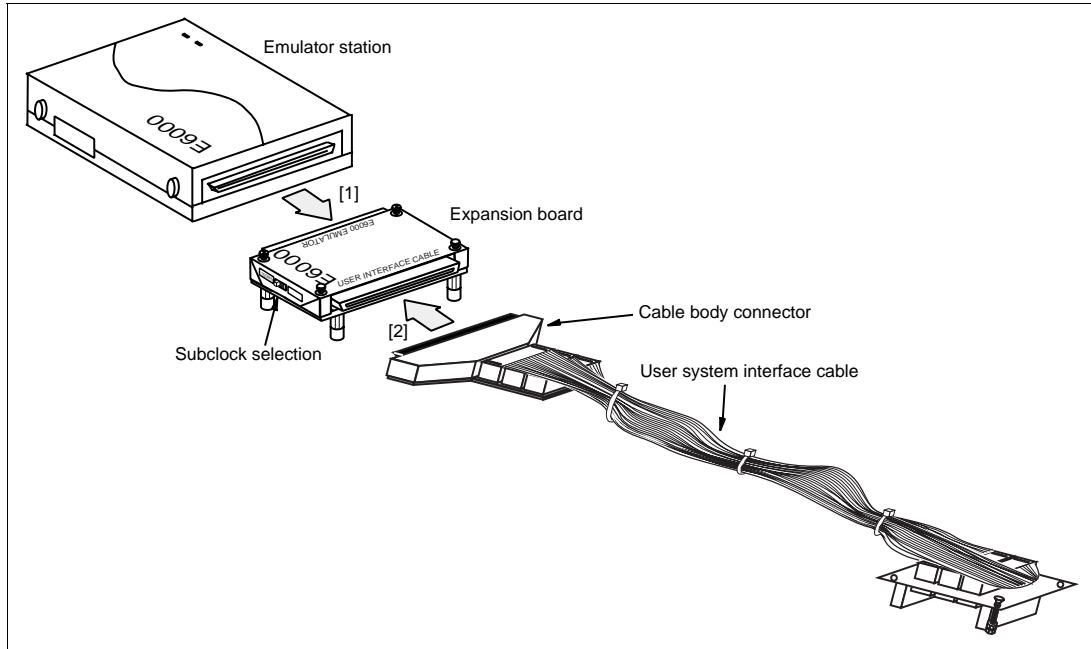

Figure 2 Connecting User System Interface Cable to Expansion Board

2.2 Connecting User System Interface Cable to User System

WARNING

Always switch OFF the user system and the emulator product before the USER SYSTEM INTERFACE CABLE is connected to or removed from any part. Before connecting, make sure that pin 1 on both sides are correctly aligned. Failure to do so will result in a FIRE HAZARD and will damage the user system, the emulator product, and the expansion board or will result in PERSONAL INJURY. The USER PROGRAM will be LOST.

To connect the cable head to the user system, follow the instructions below.

2.2.1 Installing IC Socket

After checking the location of pin 1 on the IC socket fasten it to the user system before soldering.

CAUTION

After confirming the location of pin 1 on the IC socket, apply epoxy resin adhesive to the end of the four projections at the bottom of the IC socket, and fasten it to the user system.

Use the guide pins provided to determine where to install the IC socket, as shown in figure 3.

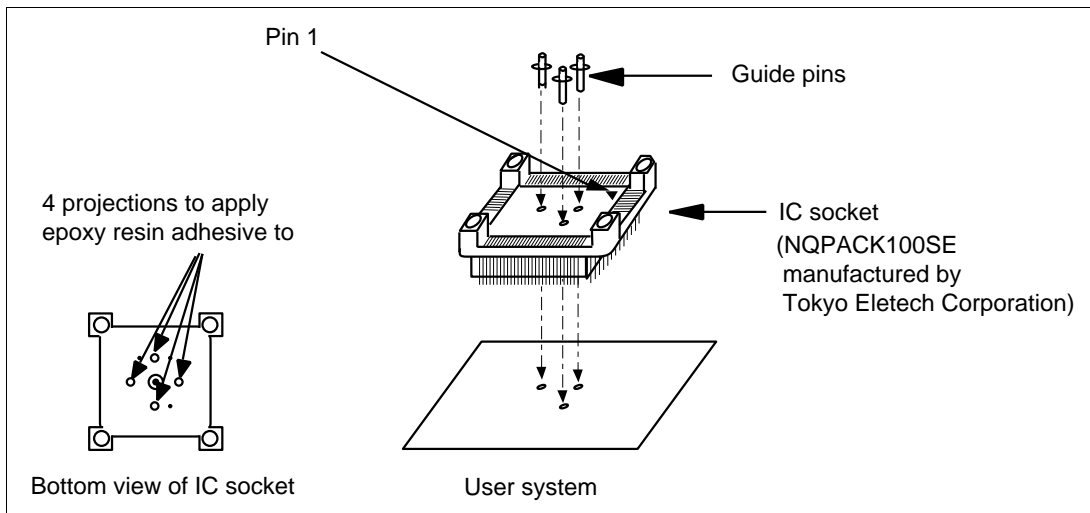

Figure 3 Location Setting of IC Socket

2.2.2 Soldering IC Socket

After fastening, solder the IC socket for a TFP-100G package to the user system.

CAUTION

Be sure to completely solder the leads so that the solder slops gently over the leads and forms solder fillets. (Use slightly more solder than the MCU.)

2.2.3 Inserting Cable Head

CAUTION

Check the location of pin 1 before inserting.

Align pin 1 on the IC socket for a TFP-100G package on the user system with pin 1 on the user system interface cable head, and insert the user system interface cable head into the IC socket on the user system, as shown in figure 4.

2.2.4 Fastening Cable Head

CAUTION

1. Use a screwdriver whose head matches the screw head.
2. The tightening torque must be 0.054 N•m or less.
If the applied torque cannot be accurately measured, stop tightening when the force required to turn the screw becomes significantly greater than that needed when first tightening. If a screw is tightened too much, the screw head may break or an IC socket contact error may be caused by a crack in the IC socket solder.
3. If the emulator does not operate correctly, cracks might have occurred in the solder. Check conduction with a tester and re-solder the IC socket if necessary.

Fasten the user system interface cable head to the IC socket for a TFP-100G package on the user system with the four screws (M2.0 x 10 mm) provided. Each screw should be tightened a little at a time, alternating between screws on opposing corners. Take special care, such as manually securing the IC socket soldered area, to prevent the soldered IC socket from being damaged by overtightening the screws or twisting the components.

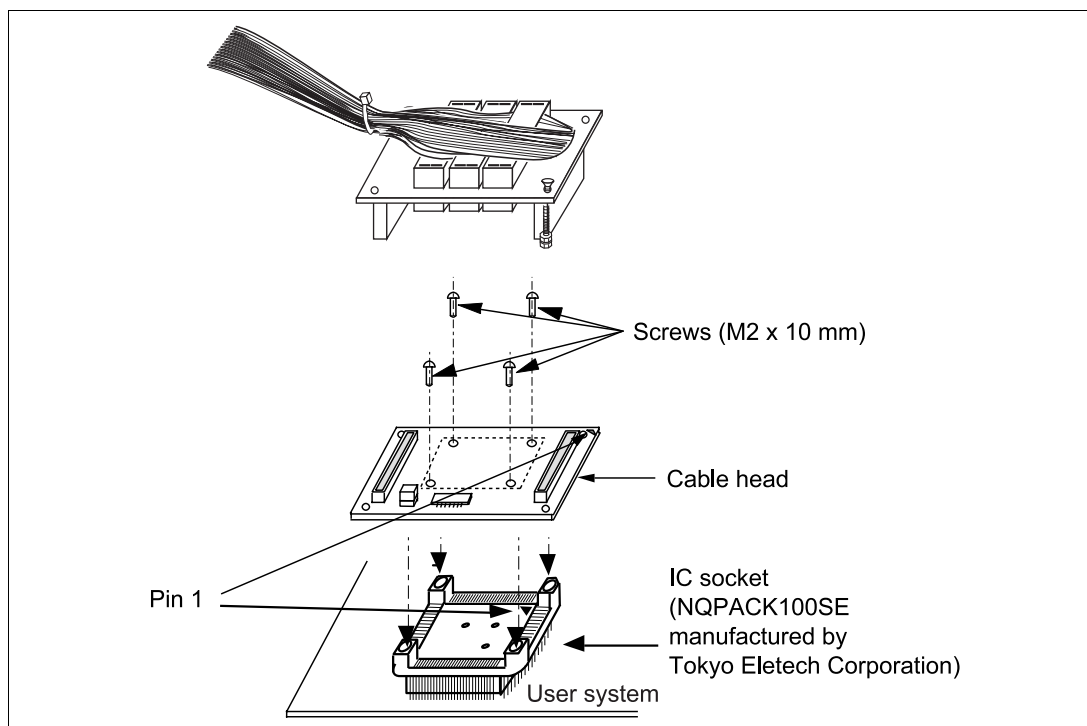

Figure 4 Connecting User System Interface Cable to User System

2.2.5 Fastening Cable Body

Connect the cable body to the cable head.

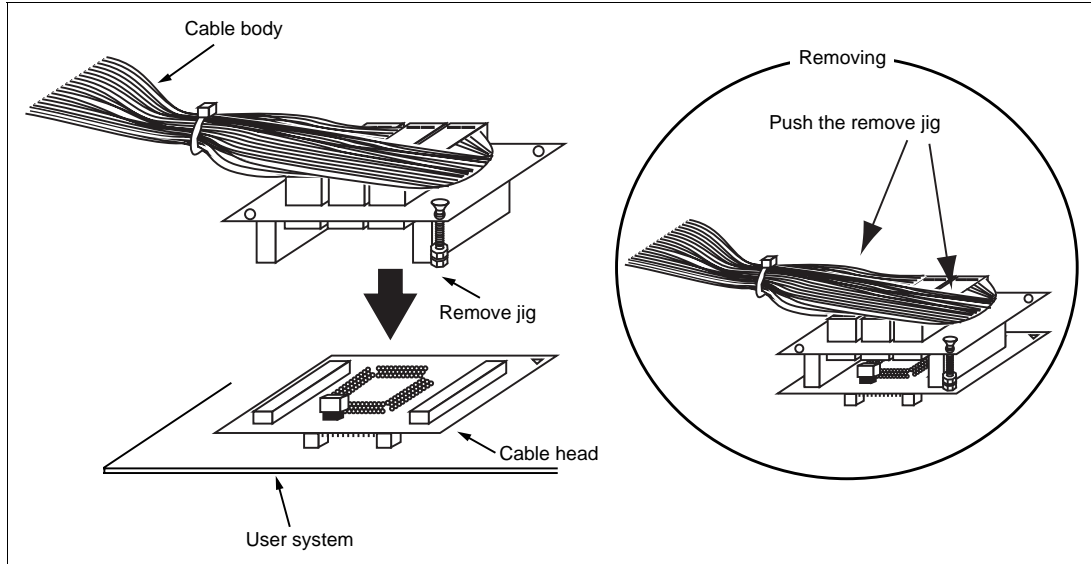

Figure 5 Fastening Cable Body

2.3 Recommended Dimensions for User System Mount Pad

Figure 6 shows the recommended dimensions for the mount pad (footprint) for the user system with an IC socket for a TFP-100G package (NQPACK100SE: manufactured by Tokyo Eletech Corporation). Note that the dimensions in figure 6 are somewhat different from those of the actual chip's mount pad.

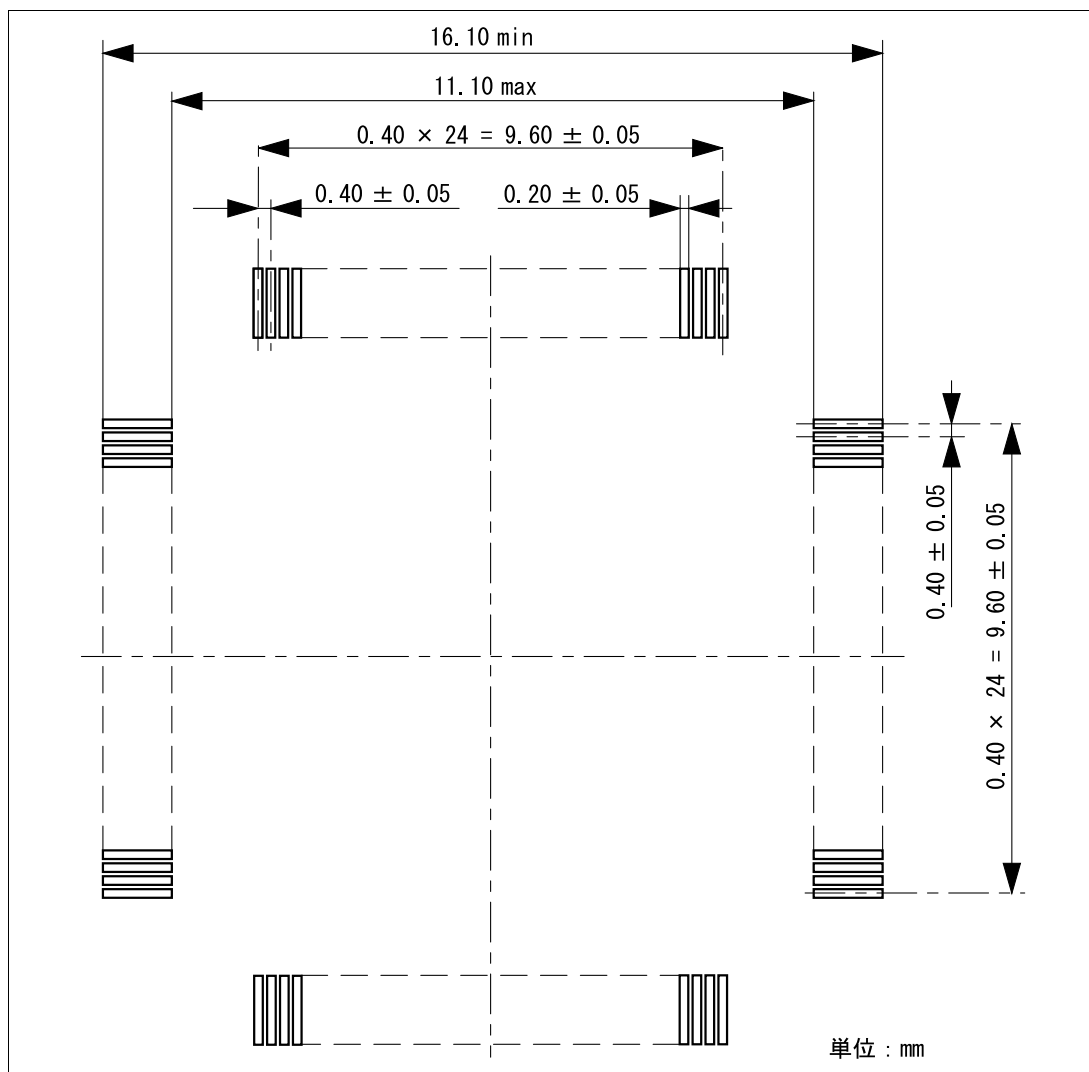

Figure 6 Recommended Dimensions for Mount Pad

2.4 Dimensions for User System Interface Cable Head

The dimensions for the user system interface cable head are shown in figure 7.

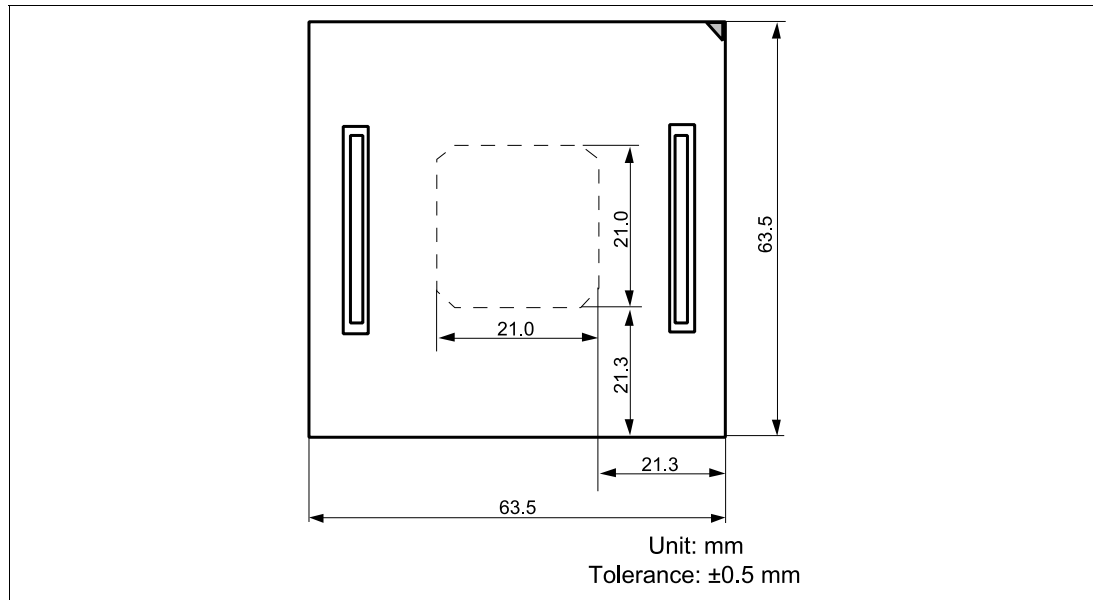

Figure 7 Dimensions for User System Interface Cable Head

2.5 Resulting Dimensions after Connecting User System Interface Cable

The resulting dimensions, after connecting the user system interface cable head to the user system, are shown in figure 8.

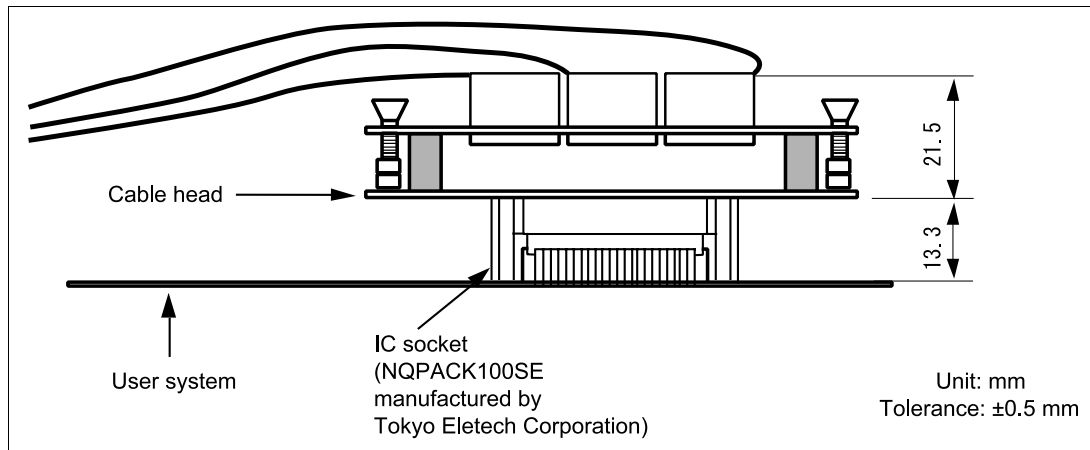

Figure 8 Resulting Dimensions after Connecting User System Interface Cable

Section 3 Installing the MCU to the User System

CAUTION

- 1. Check the location of pin 1 before inserting.**
- 2. Use a screwdriver whose head matches the screw head.**
- 3. The tightening torque must be 0.054 N•m or less.
If the applied torque cannot be accurately measured, stop tightening when the force required to turn the screw becomes significantly greater than that needed when first tightening. If a screw is tightened too much, the screw head may break or an IC socket contact error may be caused by a crack in the IC socket solder.**
- 4. If the MCU does not operate correctly, cracks might have occurred in the solder. Check conduction with a tester and re-solder the IC socket if necessary.**

Check the location of pin 1 before inserting the MCU into the IC socket on the user system, as shown in figure 9. After inserting the MCU, fasten the socket cover with the provided four screws (M2.0 x 6 mm). Take special care, such as manually securing the IC socket soldered area, to prevent the IC socket from being damaged by overtightening the screws or twisting the components.

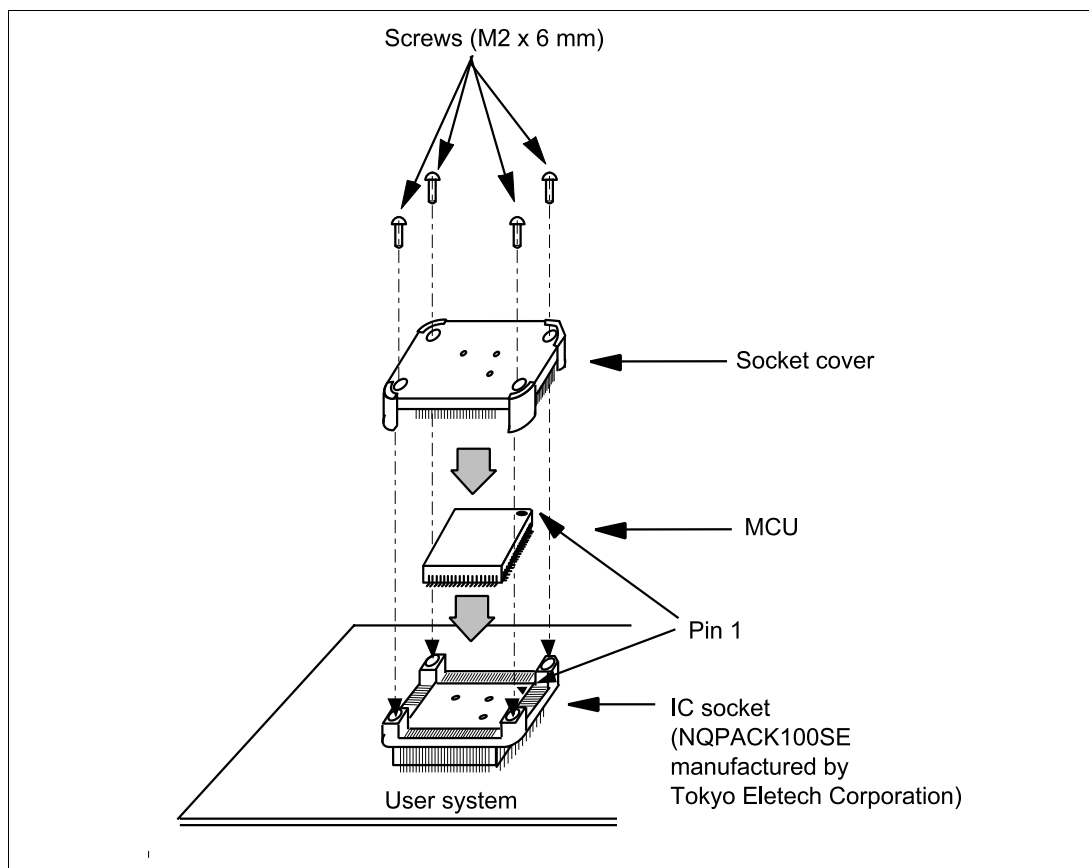

Figure 9 Installing MCU to User System

4. Subclock (OSC2, 1)

When the switch is set on the expansion I/O board (Subclock selection) and jumper P4 is set on the user system interface cable, subclocks in table 2 can be selected. Select target subclock in the Configuration window (see figures 11 and 12).

Table 2 Setting Subclock

Expansion I/O Board (Subclock selection)	User System Interface Cable (P4)	Subclock (\varnothing_{SUB})
160 kHz	1-2 connected	160 kHz
76.8 kHz		76.8 kHz
The setting of the subclock selection switch can be either 160 kHz or 76.8 kHz.	2-3 connected	Target subclock

Figure 11 shows the Expansion I/O board Subclock Selection, and figure 12 shows the location of jumper P4.

Figure 13 shows the system clock oscillator on the subclock oscillator.

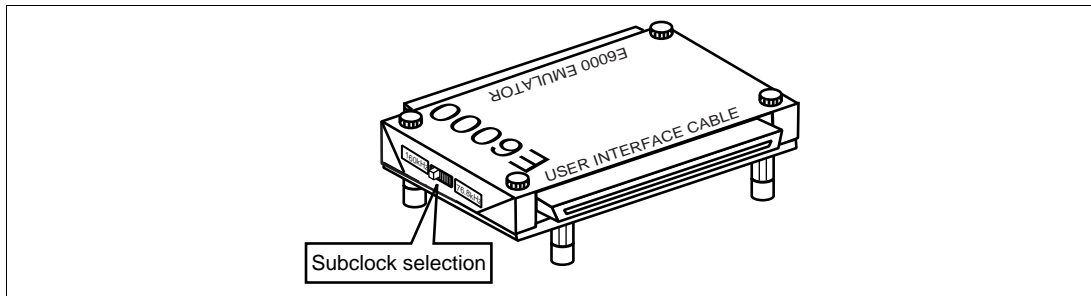

Figure 11 Expansion I/O Board Subclock Selection

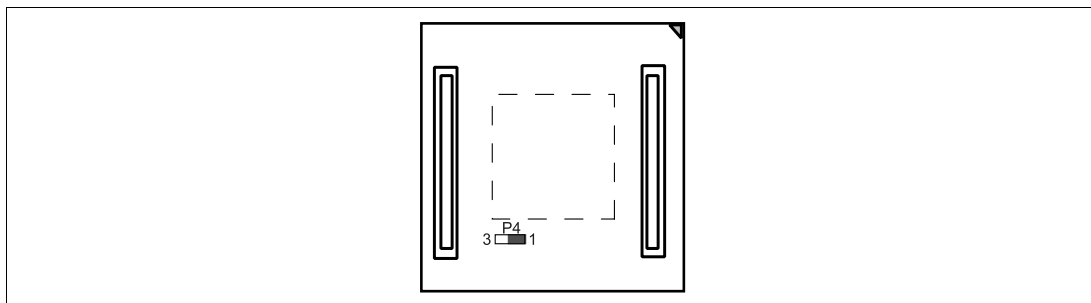

Figure 12 P4 Jumper

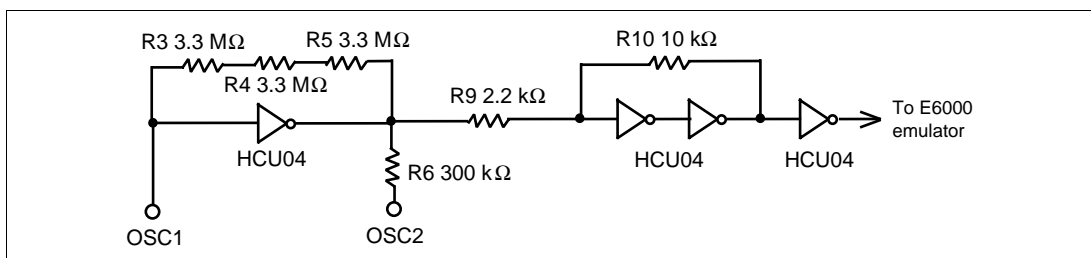

Figure 13 Subclock Oscillator

Section 5 Notice

1. Make sure that pin 1 on the user system IC socket is correctly aligned with pin 1 on the cable head before inserting the cable head into the user system IC socket.
2. The dimensions of the recommended mount pad for the user system IC socket are different from those of the MCU.
3. To avoid breaking wires in the cable body, do not place heavy or sharp metal objects on the user system interface cable.
4. While the emulator station is connected to the user system with the user system interface cable, force must not be applied to the cable head. Position the emulator station, user system interface cable, and user system as shown in figure 14.

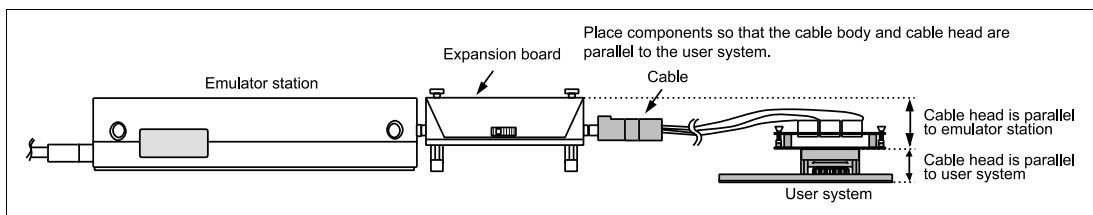

Figure 14 User System Interface Cable Location Example

5. The P1 jumper is used for testing. Do not remove the inserted jumper pin.

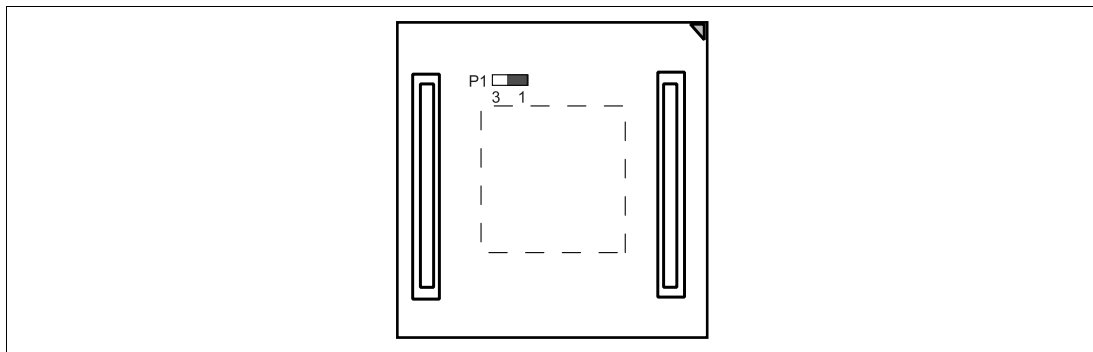

Figure 15 P1 Jumper