

To our customers,

---

## Old Company Name in Catalogs and Other Documents

---

On April 1<sup>st</sup>, 2010, NEC Electronics Corporation merged with Renesas Technology Corporation, and Renesas Electronics Corporation took over all the business of both companies. Therefore, although the old company name remains in this document, it is a valid Renesas Electronics document. We appreciate your understanding.

Renesas Electronics website: <http://www.renesas.com>

April 1<sup>st</sup>, 2010  
Renesas Electronics Corporation

Issued by: Renesas Electronics Corporation (<http://www.renesas.com>)

Send any inquiries to <http://www.renesas.com/inquiry>.

## Notice

1. All information included in this document is current as of the date this document is issued. Such information, however, is subject to change without any prior notice. Before purchasing or using any Renesas Electronics products listed herein, please confirm the latest product information with a Renesas Electronics sales office. Also, please pay regular and careful attention to additional and different information to be disclosed by Renesas Electronics such as that disclosed through our website.
2. Renesas Electronics does not assume any liability for infringement of patents, copyrights, or other intellectual property rights of third parties by or arising from the use of Renesas Electronics products or technical information described in this document. No license, express, implied or otherwise, is granted hereby under any patents, copyrights or other intellectual property rights of Renesas Electronics or others.
3. You should not alter, modify, copy, or otherwise misappropriate any Renesas Electronics product, whether in whole or in part.
4. Descriptions of circuits, software and other related information in this document are provided only to illustrate the operation of semiconductor products and application examples. You are fully responsible for the incorporation of these circuits, software, and information in the design of your equipment. Renesas Electronics assumes no responsibility for any losses incurred by you or third parties arising from the use of these circuits, software, or information.
5. When exporting the products or technology described in this document, you should comply with the applicable export control laws and regulations and follow the procedures required by such laws and regulations. You should not use Renesas Electronics products or the technology described in this document for any purpose relating to military applications or use by the military, including but not limited to the development of weapons of mass destruction. Renesas Electronics products and technology may not be used for or incorporated into any products or systems whose manufacture, use, or sale is prohibited under any applicable domestic or foreign laws or regulations.
6. Renesas Electronics has used reasonable care in preparing the information included in this document, but Renesas Electronics does not warrant that such information is error free. Renesas Electronics assumes no liability whatsoever for any damages incurred by you resulting from errors in or omissions from the information included herein.
7. Renesas Electronics products are classified according to the following three quality grades: “Standard”, “High Quality”, and “Specific”. The recommended applications for each Renesas Electronics product depends on the product’s quality grade, as indicated below. You must check the quality grade of each Renesas Electronics product before using it in a particular application. You may not use any Renesas Electronics product for any application categorized as “Specific” without the prior written consent of Renesas Electronics. Further, you may not use any Renesas Electronics product for any application for which it is not intended without the prior written consent of Renesas Electronics. Renesas Electronics shall not be in any way liable for any damages or losses incurred by you or third parties arising from the use of any Renesas Electronics product for an application categorized as “Specific” or for which the product is not intended where you have failed to obtain the prior written consent of Renesas Electronics. The quality grade of each Renesas Electronics product is “Standard” unless otherwise expressly specified in a Renesas Electronics data sheets or data books, etc.
  - “Standard”: Computers; office equipment; communications equipment; test and measurement equipment; audio and visual equipment; home electronic appliances; machine tools; personal electronic equipment; and industrial robots.
  - “High Quality”: Transportation equipment (automobiles, trains, ships, etc.); traffic control systems; anti-disaster systems; anti-crime systems; safety equipment; and medical equipment not specifically designed for life support.
  - “Specific”: Aircraft; aerospace equipment; submersible repeaters; nuclear reactor control systems; medical equipment or systems for life support (e.g. artificial life support devices or systems), surgical implantations, or healthcare intervention (e.g. excision, etc.), and any other applications or purposes that pose a direct threat to human life.
8. You should use the Renesas Electronics products described in this document within the range specified by Renesas Electronics, especially with respect to the maximum rating, operating supply voltage range, movement power voltage range, heat radiation characteristics, installation and other product characteristics. Renesas Electronics shall have no liability for malfunctions or damages arising out of the use of Renesas Electronics products beyond such specified ranges.
9. Although Renesas Electronics endeavors to improve the quality and reliability of its products, semiconductor products have specific characteristics such as the occurrence of failure at a certain rate and malfunctions under certain use conditions. Further, Renesas Electronics products are not subject to radiation resistance design. Please be sure to implement safety measures to guard them against the possibility of physical injury, and injury or damage caused by fire in the event of the failure of a Renesas Electronics product, such as safety design for hardware and software including but not limited to redundancy, fire control and malfunction prevention, appropriate treatment for aging degradation or any other appropriate measures. Because the evaluation of microcomputer software alone is very difficult, please evaluate the safety of the final products or system manufactured by you.
10. Please contact a Renesas Electronics sales office for details as to environmental matters such as the environmental compatibility of each Renesas Electronics product. Please use Renesas Electronics products in compliance with all applicable laws and regulations that regulate the inclusion or use of controlled substances, including without limitation, the EU RoHS Directive. Renesas Electronics assumes no liability for damages or losses occurring as a result of your noncompliance with applicable laws and regulations.
11. This document may not be reproduced or duplicated, in any form, in whole or in part, without prior written consent of Renesas Electronics.
12. Please contact a Renesas Electronics sales office if you have any questions regarding the information contained in this document or Renesas Electronics products, or if you have any other inquiries.

(Note 1) “Renesas Electronics” as used in this document means Renesas Electronics Corporation and also includes its majority-owned subsidiaries.

(Note 2) “Renesas Electronics product(s)” means any product developed or manufactured by or for Renesas Electronics.

To all our customers

---

## **Regarding the change of names mentioned in the document, such as Hitachi Electric and Hitachi XX, to Renesas Technology Corp.**

---

The semiconductor operations of Mitsubishi Electric and Hitachi were transferred to Renesas Technology Corporation on April 1st 2003. These operations include microcomputer, logic, analog and discrete devices, and memory chips other than DRAMs (flash memory, SRAMs etc.) Accordingly, although Hitachi, Hitachi, Ltd., Hitachi Semiconductors, and other Hitachi brand names are mentioned in the document, these names have in fact all been changed to Renesas Technology Corp. Thank you for your understanding. Except for our corporate trademark, logo and corporate statement, no changes whatsoever have been made to the contents of the document, and these changes do not constitute any alteration to the contents of the document itself.

Renesas Technology Home Page: <http://www.renesas.com>

Renesas Technology Corp.  
Customer Support Dept.  
April 1, 2003

**H8/3657 Series TQFP-80C  
User System Interface Cable  
(HS3657ECN62H) for E6000 Emulator  
User's Manual**



# IMPORTANT INFORMATION

## READ FIRST

- **READ this user's manual before using this user system interface cable.**
- **KEEP the user's manual handy for future reference.**

**Do not attempt to use the user system interface cable until you fully understand its mechanism.**

### **User System Interface Cable:**

Throughout this document, the term "user system interface cable" shall be defined as the following product produced only by Hitachi, Ltd. excluding all subsidiary products.

- User system interface cable (HS3657ECN62H)

The user system or a host computer is not included in this definition.

### **Purpose of the User System Interface Cable:**

This user system interface cable is for connecting the emulator station and user system. This user system interface cable must only be used for the above purpose.

### **Improvement Policy:**

Hitachi, Ltd. (including its subsidiaries, hereafter collectively referred to as Hitachi) pursues a policy of continuing improvement in design, performance, functions, and safety of the user system interface cable. Hitachi reserves the right to change, wholly or partially, the specifications, design, user's manual, and other documentation at any time without notice.

### **Target User of the User System Interface Cable:**

This user system interface cable should only be used by those who have carefully read and thoroughly understood the information and restrictions contained in the user's manual. Do not attempt to use the user system interface cable until you fully understand its mechanism.

It is highly recommended that first-time users be instructed by users that are well versed in the operation of the user system interface cable.

## **LIMITED WARRANTY**

Hitachi warrants its user system interface cables to be manufactured in accordance with published specifications and free from defects in material and/or workmanship. Hitachi will repair or replace any user system interface cables determined to be defective in material and/or workmanship. User system interface cables are wearing parts which Hitachi will not repair or replace if damaged and/or worn through use. The foregoing shall constitute the sole remedy for any breach of Hitachi's warranty. This warranty extends only to you, the original Purchaser. It is not transferable to anyone who subsequently purchases the user system interface cable from you. Hitachi is not liable for any claim made by a third party or made by you for a third party.

## **DISCLAIMER**

HITACHI MAKES NO WARRANTIES, EITHER EXPRESS OR IMPLIED, ORAL OR WRITTEN, EXCEPT AS PROVIDED HEREIN, INCLUDING WITHOUT LIMITATION THEREOF, WARRANTIES AS TO MARKETABILITY, MERCHANTABILITY, FITNESS FOR ANY PARTICULAR PURPOSE OR USE, OR AGAINST INFRINGEMENT OF ANY PATENT. IN NO EVENT SHALL HITACHI BE LIABLE FOR ANY DIRECT, INCIDENTAL OR CONSEQUENTIAL DAMAGES OF ANY NATURE, OR LOSSES OR EXPENSES RESULTING FROM ANY DEFECTIVE USER SYSTEM INTERFACE CABLE, THE USE OF ANY USER SYSTEM INTERFACE CABLE, OR ITS DOCUMENTATION, EVEN IF ADVISED OF THE POSSIBILITY OF SUCH DAMAGES. EXCEPT AS EXPRESSLY STATED OTHERWISE IN THIS WARRANTY, THIS USER SYSTEM INTERFACE CABLE IS SOLD "AS IS ", AND YOU MUST ASSUME ALL RISK FOR THE USE AND RESULTS OBTAINED FROM THE USER SYSTEM INTERFACE CABLE.

**State Law:**

Some states do not allow the exclusion or limitation of implied warranties or liability for incidental or consequential damages, so the above limitation or exclusion may not apply to you. This warranty gives you specific legal rights, and you may have other rights which may vary from state to state.

**The Warranty is Void in the Following Cases:**

Hitachi shall have no liability or legal responsibility for any problems caused by misuse, abuse, misapplication, neglect, improper handling, installation, repair or modifications of the user system interface cable without Hitachi's prior written consent or any problems caused by the user system.

**All Rights Reserved:**

This user's manual and user system interface cable are copyrighted and all rights are reserved by Hitachi. No part of this user's manual, all or part, may be reproduced or duplicated in any form, in hard-copy or machine-readable form, by any means available without Hitachi's prior written consent.

**Other Important Things to Keep in Mind:**

1. Circuitry and other examples described herein are meant merely to indicate the characteristics and performance of Hitachi's semiconductor products. Hitachi assumes no responsibility for any intellectual property claims or other problems that may result from applications based on the examples described herein.
2. No license is granted by implication or otherwise under any patents or other rights of any third party or Hitachi.

**Figures:**

Some figures in this user's manual may show items different from your actual system.

**Limited Anticipation of Danger:**

Hitachi cannot anticipate every possible circumstance that might involve a potential hazard. The warnings in this user's manual and on the user system interface cable are therefore not all inclusive. Therefore, you must use the user system interface cable safely at your own risk.

# SAFETY PAGE

## READ FIRST

- **READ** this user's manual before using this user system interface cable.
- **KEEP the user's manual handy for future reference.**

Do not attempt to use the user system interface cable until you fully understand its mechanism.

## DEFINITION OF SIGNAL WORDS



This is the safety alert symbol. It is used to alert you to potential personal injury hazards. Obey all safety messages that follow this symbol to avoid possible injury or death.



**DANGER** indicates an imminently hazardous situation which, if not avoided, will result in death or serious injury.



**WARNING** indicates a potentially hazardous situation which, if not avoided, could result in death or serious injury.



**CAUTION** indicates a potentially hazardous situation which, if not avoided, may result in minor or moderate injury.



**CAUTION** used without the safety alert symbol indicates a potentially hazardous situation which, if not avoided, may result in property damage.

**NOTE** emphasizes essential information.

## **WARNING**

Observe the precautions listed below. Failure to do so will result in a **FIRE HAZARD** and will damage the user system and the emulator product or will result in **PERSONAL INJURY**. The **USER PROGRAM** will be **LOST**.

1. Do not repair or remodel the emulator product by yourself for electric shock prevention and quality assurance.
2. Always switch **OFF** the E6000 emulator and user system before connecting or disconnecting any **CABLES** or **PARTS**.
3. Always before connecting any **CABLES**, make sure that pin 1 on both sides are correctly aligned.
4. Supply power according to the power specifications and do not apply an incorrect power voltage. Use only the provided power cable.

## Cautions

1. Hitachi neither warrants nor grants licenses of any rights of Hitachi's or any third party's patent, copyright, trademark, or other intellectual property rights for information contained in this document. Hitachi bears no responsibility for problems that may arise with third party's rights, including intellectual property rights, in connection with use of the information contained in this document.
2. Products and product specifications may be subject to change without notice. Confirm that you have received the latest product standards or specifications before final design, purchase or use.
3. Hitachi makes every attempt to ensure that its products are of high quality and reliability. However, contact Hitachi's sales office before using the product in an application that demands especially high quality and reliability or where its failure or malfunction may directly threaten human life or cause risk of bodily injury, such as aerospace, aeronautics, nuclear power, combustion control, transportation, traffic, safety equipment or medical equipment for life support.
4. Design your application so that the product is used within the ranges guaranteed by Hitachi particularly for maximum rating, operating supply voltage range, heat radiation characteristics, installation conditions and other characteristics. Hitachi bears no responsibility for failure or damage when used beyond the guaranteed ranges. Even within the guaranteed ranges, consider normally foreseeable failure rates or failure modes in semiconductor devices and employ systemic measures such as fail-safes, so that the equipment incorporating Hitachi product does not cause bodily injury, fire or other consequential damage due to operation of the Hitachi product.
5. This product is not designed to be radiation resistant.
6. No one is permitted to reproduce or duplicate, in any form, the whole or part of this document without written approval from Hitachi.
7. Contact Hitachi's sales office for any questions regarding this document or Hitachi semiconductor products.







## Preface

Thank you for purchasing this user system interface cable (HS3657ECN62H) for the Hitachi's original microcomputer H8/3644, 3657 series.

The HS3657ECN62H is a user system interface cable that connects an H8/3644, 3657 series E6000 emulator (HS3644EPI60H; hereinafter referred to as the emulator) to the IC socket for a TQFP-80C package (package code: TFP-80C) for the H8/3657 series MCU on the user system.

# Contents

Section 1	Configuration .....	1
Section 2	Connection Procedures .....	4
2.1	Connecting User System Interface Cable to Emulator Station .....	4
2.2	Connecting User System Interface Cable to User System .....	6
2.2.1	Installing IC Socket .....	6
2.2.2	Soldering IC Socket.....	6
2.2.3	Inserting Cable Head .....	7
2.2.4	Fastening Cable Head.....	7
2.2.5	Fastening Cable Body.....	9
2.3	Recommended Dimensions for User System Mount Pad .....	10
2.4	Dimensions for User System Interface Cable Head.....	11
2.5	Resulting Dimensions after Connecting User System Interface Cable .....	12
Section 3	Installing the MCU to the User System .....	13
Section 4	Verifying Operation .....	15
Section 5	Notice.....	17

## Section 1 Configuration

### **CAUTION**

**Use an IC149-080-058-B51 socket (manufactured by YAMAICHI ELECTRONICS Co., Ltd.) for the TFP-80C package IC socket on the user system.**

Figure 1 shows the configuration of the HS3657ECN62H user system interface cable for the TFP-80C package.

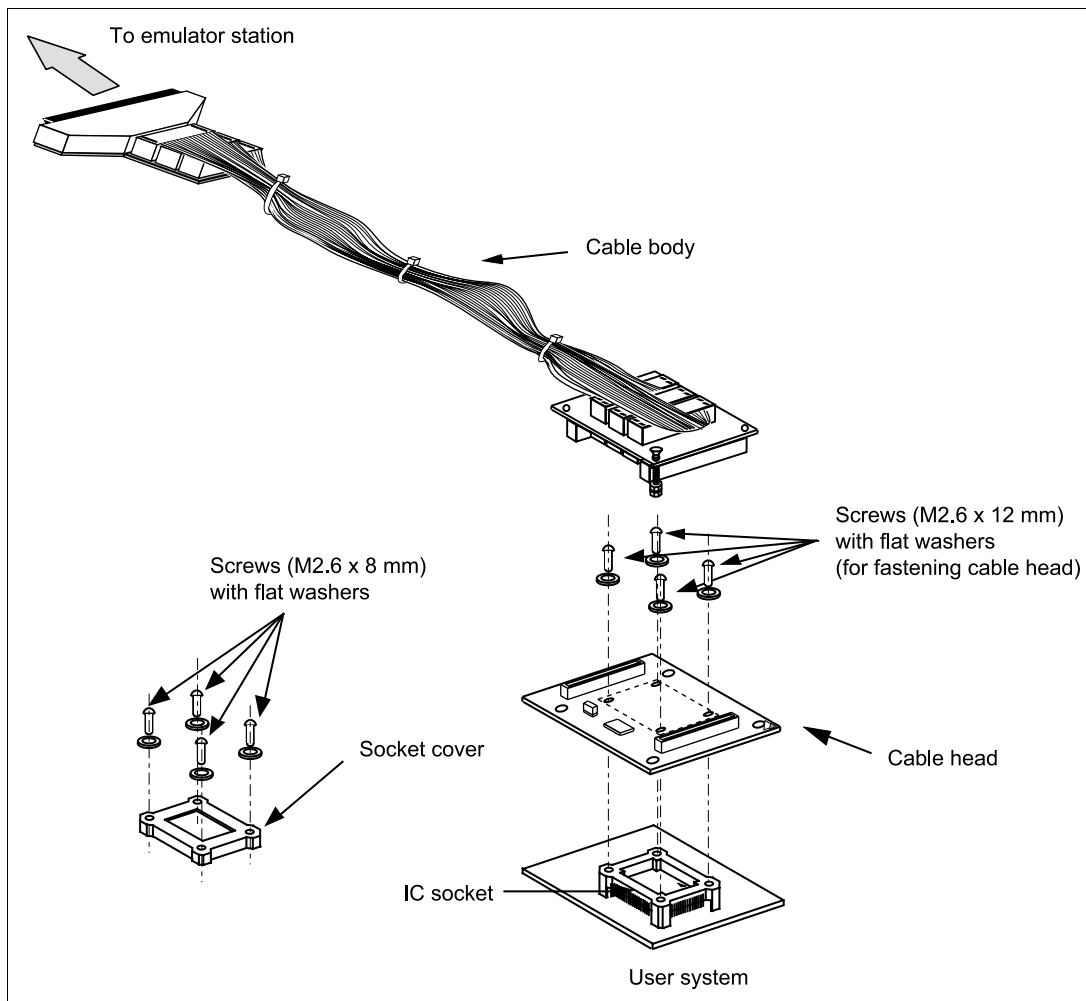

**Figure 1 HS3657ECN62H User System Interface Cable**

Table 1 lists the HS3657ECN62H components. Please make sure you have all of these components when unpacking.

**Table 1 HS3657ECN62H Components**

<b>No.</b>	<b>Component</b>	<b>Quantity</b>	<b>Remarks</b>
1	Cable body	1	Flat cable
2	Cable head	1	
3	IC socket	1	For the TFP-80C package
4	Socket cover	1	For installing an TFP-80C-packaged MCU
5	Screws (M2.6 x 12 mm)	4	For fastening cable head MCU (with four flat washers)
6	Screws (M2.6 x 8 mm)	4	For installing an TFP-80C-packaged MCU (with four flat washers)
7	Documentation	1	User's manual for HS3657ECN62H (this manual)

## Section 2 Connection Procedures

### 2.1 Connecting User System Interface Cable to Emulator Station

#### **WARNING**

**Observe the precautions listed below. Failure to do so will result in a FIRE HAZARD and will damage the user system and the emulator product or will result in PERSONAL INJURY. The USER PROGRAM will be LOST.**

- 1. Always switch OFF the user system and the emulator product before the USER SYSTEM INTERFACE CABLE is connected to or removed from any part. Before connecting, make sure that pin 1 on both sides are correctly aligned.**
- 2. The user system interface cable dedicated to the emulator must be used.**

To connect the cable body to the emulator station, follow the instructions below.

1. Make sure the user system and emulator station are turned off.
2. After making sure the direction of the cable body connector is correct, firmly insert the cable body connector into the emulator station socket (figure 2).

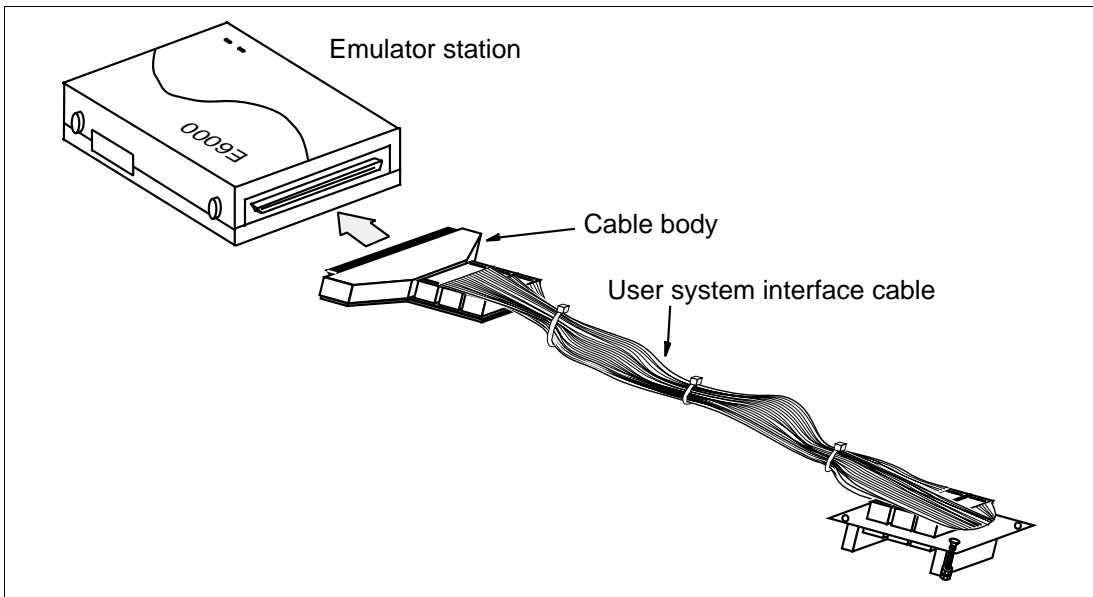

**Figure 2 Connecting User System Interface Cable to Emulator Station**

## 2.2 Connecting User System Interface Cable to User System

### **WARNING**

**Always switch OFF the user system and the emulator product before the USER SYSTEM INTERFACE CABLE is connected to or removed from any part. Before connecting, make sure that pin 1 on both sides are correctly aligned. Failure to do so will result in a FIRE HAZARD and will damage the user system and the emulator product or will result in PERSONAL INJURY. The USER PROGRAM will be LOST.**

To connect the cable head to the user system, follow the instructions below.

#### 2.2.1 Installing IC Socket

After checking the location of pin 1 on the IC socket, apply epoxy resin adhesive to the bottom of the IC socket for an TFP-80C package, and fasten it to the user system before soldering.

#### 2.2.2 Soldering IC Socket

After fastening, solder the IC socket for an TFP-80C package to the user system. Be sure to completely solder the leads so that the solder slops gently over the leads and forms solder fillets. (Use slightly more solder than the MCU.)

### 2.2.3 Inserting Cable Head

## **CAUTION**

**Check the location of pin 1 before inserting.**

Align pin 1 on the IC socket for an TFP-80C package on the user system with pin 1 on the user system interface cable head, and insert the user system interface cable head into the IC socket on the user system, as shown in figure 3.

### 2.2.4 Fastening Cable Head

## **CAUTION**

1. **Use a Phillips-type screwdriver whose head matches the screw head.**
2. **The tightening torque must be 0.294 N•m or less.**  
**If the applied torque cannot be accurately measured, stop tightening when the force required to turn the screw becomes significantly greater than that needed when first tightening. If a screw is tightened too much, the screw head may break or an IC socket contact error may be caused by a crack in the IC socket solder.**
3. **If the emulator does not operate correctly, cracks might have occurred in the solder. Check conduction with a tester and re-solder the IC socket if necessary.**

Fasten the user system interface cable head to the IC socket for an TFP-80C package on the user system with the four screws (M2.6 x 12 mm; with four flat washers) provided. Each screw should be tightened a little at a time, alternating between screws on opposing corners. Take special care, such as manually securing the IC socket soldered area, to prevent the soldered IC socket from being damaged by overtightening the screws or twisting the components.

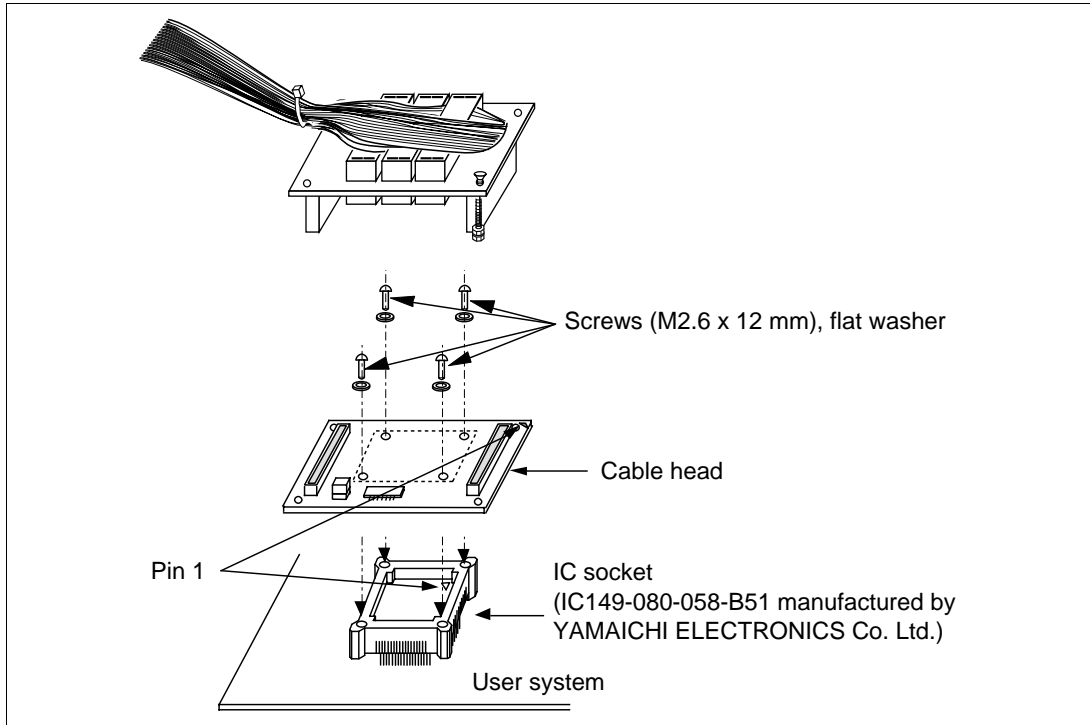

**Figure 3 Connecting User System Interface Cable to User System**

### 2.2.5 Fastening Cable Body

Connect the cable body to the cable head.

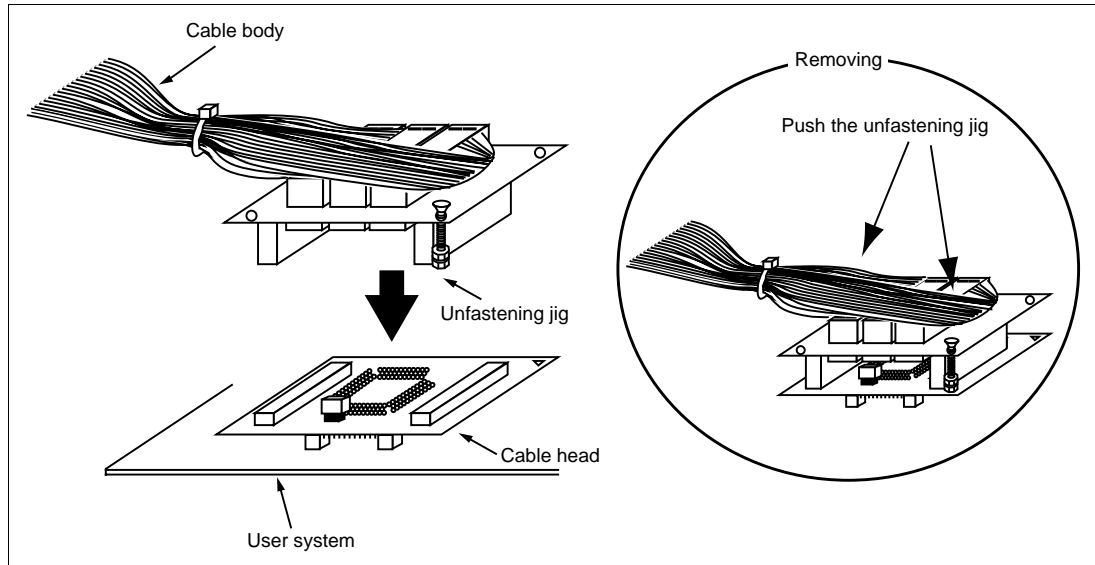

**Figure 4 Fastening Cable Body**

### 2.3 Recommended Dimensions for User System Mount Pad

Figure 5 shows the recommended dimensions for the mount pad (footprint) for the user system with an IC socket for an TFP-80C package (IC149-080-058-B51: manufactured by YAMAICHI ELECTRONICS Co., Ltd.). Note that the dimensions in figure 5 are somewhat different from those of the actual chip's mount pad.

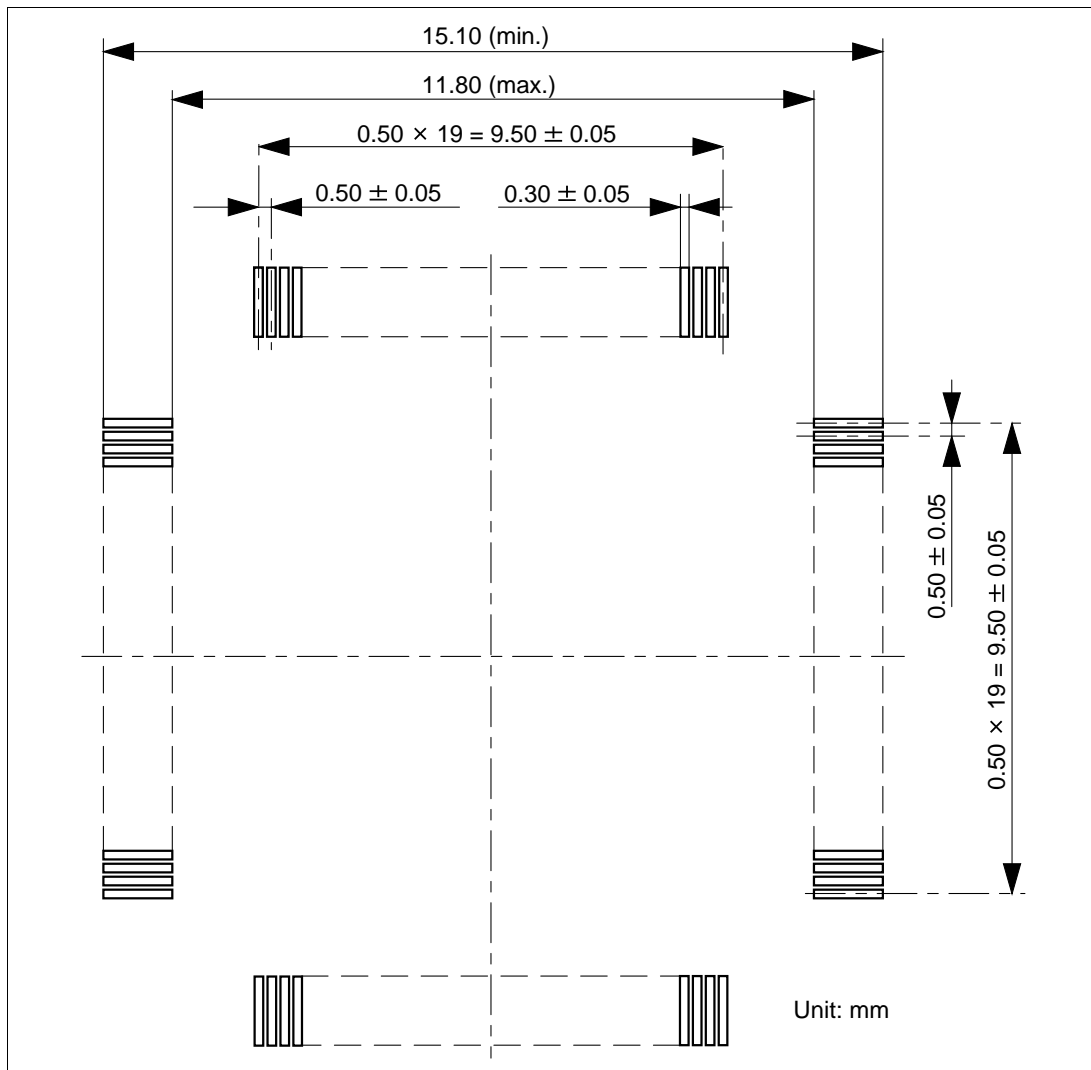

Figure 5 Recommended Dimensions for Mount Pad

## 2.4 Dimensions for User System Interface Cable Head

The dimensions for the user system interface cable head are shown in figure 6.

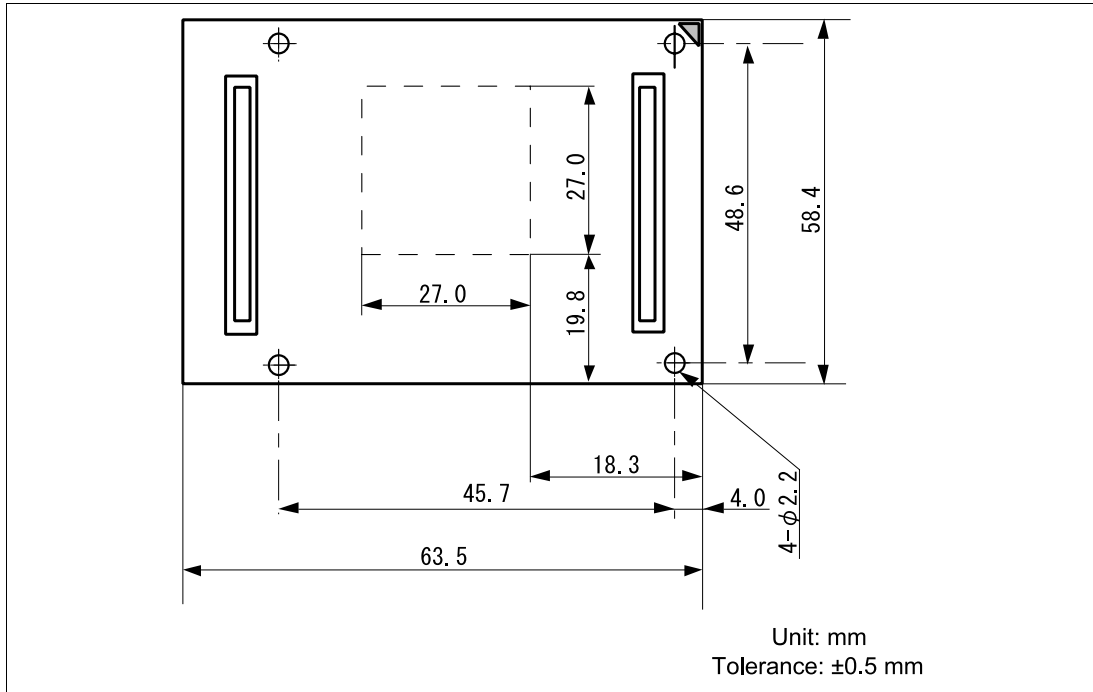
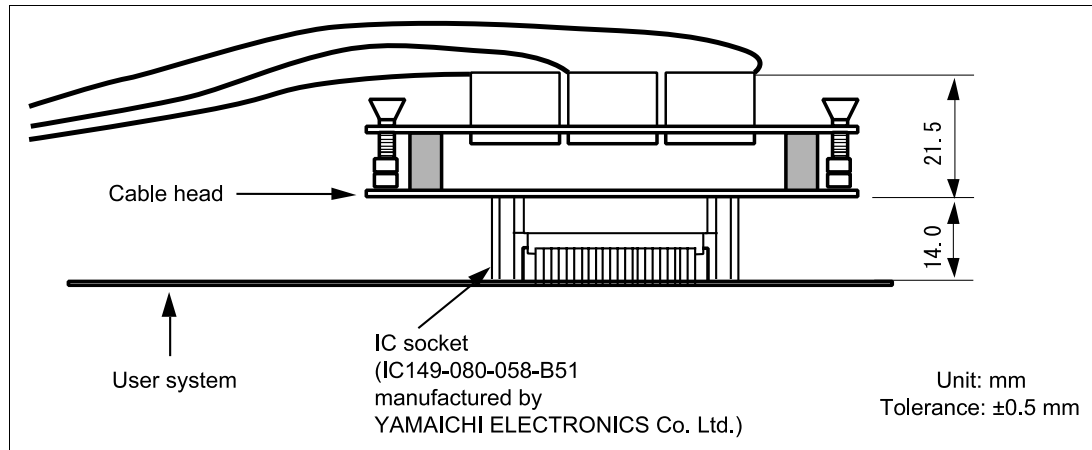

Figure 6 Dimensions for User System Interface Cable Head

## 2.5 Resulting Dimensions after Connecting User System Interface Cable

The resulting dimensions, after connecting the user system interface cable head to the user system, are shown in figure 7.



**Figure 7 Resulting Dimensions after Connecting User System Interface Cable**

## Section 3 Installing the MCU to the User System

### **CAUTION**

- 1. Check the location of pin 1 before inserting.**
- 2. Use a Phillips-type screwdriver whose head matches the screw head.**
- 3. The tightening torque must be 0.294 N•m or less.  
If the applied torque cannot be accurately measured, stop tightening when the force required to turn the screw becomes significantly greater than that needed when first tightening. If a screw is tightened too much, the screw head may break or an IC socket contact error may be caused by a crack in the IC socket solder.**
- 4. If the MCU does not operate correctly, cracks might have occurred in the solder. Check conduction with a tester and re-solder the IC socket if necessary.**

Check the location of pin 1 before inserting the MCU into the IC socket on the user system, as shown in figure 8. After inserting the MCU, fasten the socket cover with the provided four screws (M2.6 x 8 mm; with four flat washers). Take special care, such as manually securing the IC socket soldered area, to prevent the IC socket from being damaged by overtightening the screws or twisting the components.

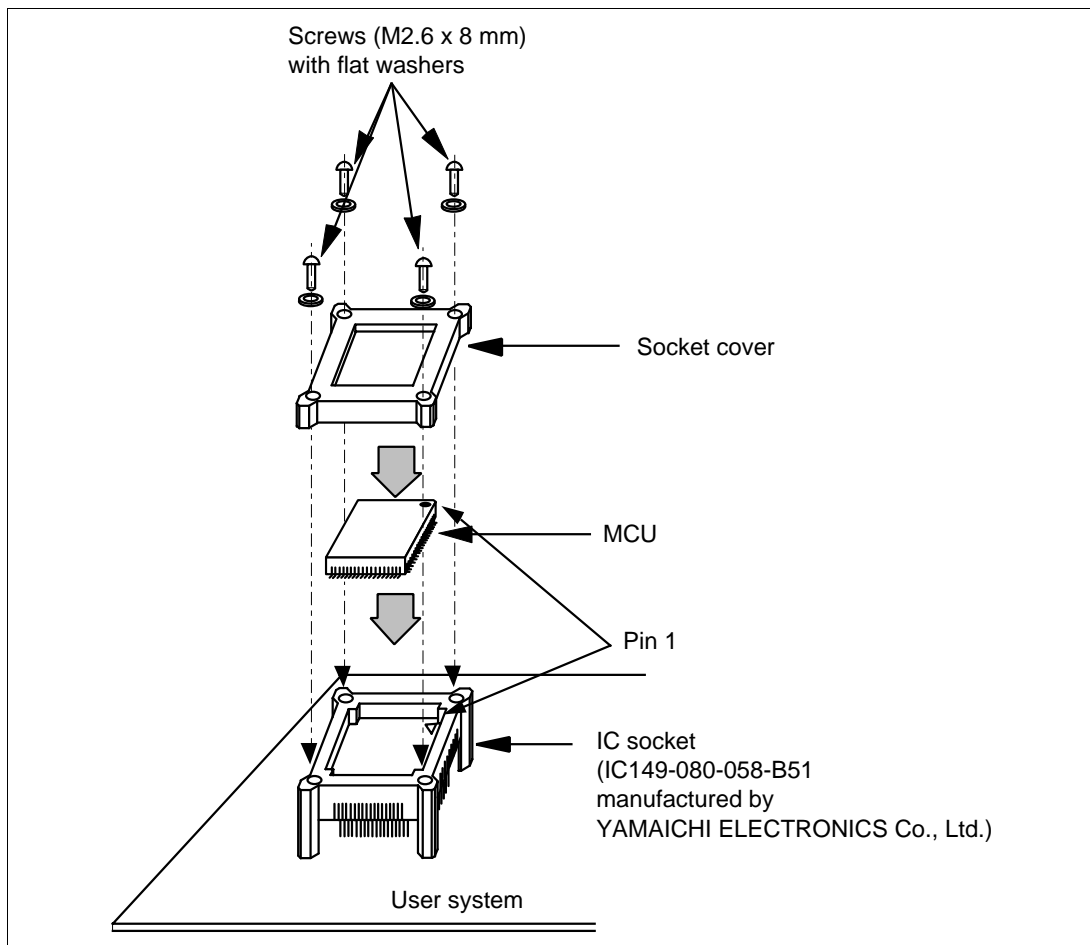
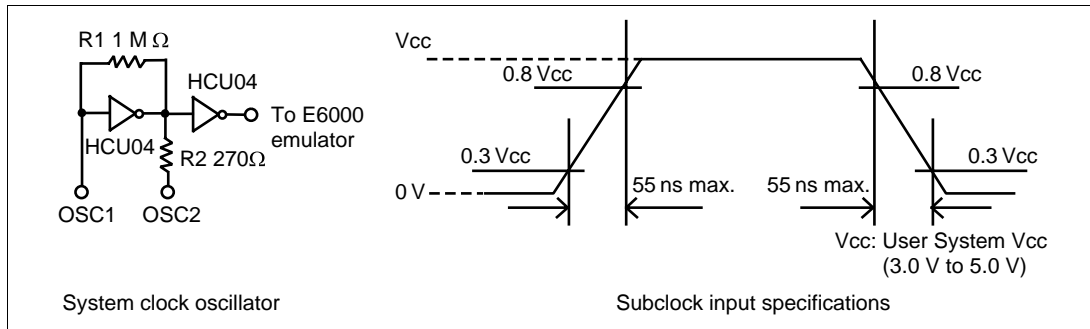

**Figure 8 Installing MCU to User System**

## Section 4 Verifying Operation

1. When using the H8/3644, 3657 series E6000 emulator (HS3644EPI60H), turn on the emulator according to the procedures described in the H8/3644, 3657 Series E6000 Emulator User's Manual (HS3008EPI60HE).
2. Verify the user system interface cable connections by accessing ports and checking the bus states of the pins. If an error is detected, recheck the soldered IC socket and the location of pin 1.
3. The emulator connected to this user system interface cable supports two kinds of clock sources: an emulator internal clock and an external clock on the user system, for the MCU clock and subclock. For details, refer to the H8/3644, 3657 Series E6000 Emulator User's Manual (HS3008EPI60HE).
  - To use the emulator internal clock  
Select the clock in the emulator station as the system clock ( $\phi$ ) and the subclock ( $\phi_w$ ), by using the CLOCK command (emulator command).
  - To use the external clock on the user system as the system clock  
Select target clock t2 with the CLOCK command (emulator command). Supply the external clock from the user system to the emulator. When a crystal oscillator is inserted into the OSC1 and OSC2 terminals for the system clock, the clock is generated by the oscillator circuits shown in figure 9. To input an external clock from the user system, input clock pulses satisfying the specifications described in the MCU hardware manual into the OSC1 terminal. The system clock ( $\phi$ ) frequency is half of the external clock frequency.
  - To use the external clock on the user system as the subclock  
Select target clock sub t with the CLOCK command (emulator command). Supply the external clock from the user system to the emulator. To input an external subclock from the user system, input clock pulses satisfying the specifications shown in figure 9 into the X1 terminal. The oscillator circuits on the user system interface cable cannot generate external subclock pulses by using the crystal oscillator connected to the user system.

Figure 9 shows the system clock oscillator on the user system interface cable and the subclock input specifications.



**Figure 9 System Clock Oscillator and Subclock Input Specifications**

## Section 5 Notice

1. Make sure that pin 1 on the user system IC socket is correctly aligned with pin 1 on the cable head before inserting the cable head into the user system IC socket.
2. The dimensions of the recommended mount pad for the user system IC socket are different from those of the MCU.
3. This user system interface cable is specifically designed for the HS3644EPI60H emulator. Do not use this cable with any other emulator station.
4. To prevent breaking of wires in the cable body, do not place heavy or sharp metal objects on the user system interface cable.
5. While the emulator station is connected to the user system with the user system interface cable, force must not be applied to the cable head. Place the emulator station, user system interface cable, and user system as shown in the example in figure 10.

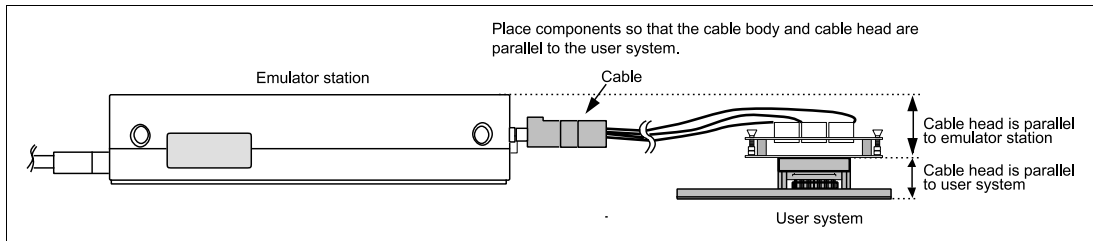

**Figure 10 User System Interface Cable Location Example**

6. The flash memory functions of the H8/3657 series are not supported by the emulator. Therefore, do not apply 12 V to Vpp/P90 and TEST pins. If 12 V is applied, the emulator will detect it as the test mode. The Vpp/P90 and TEST pins have circuits for protection against 12-V application, as shown in figure 11.

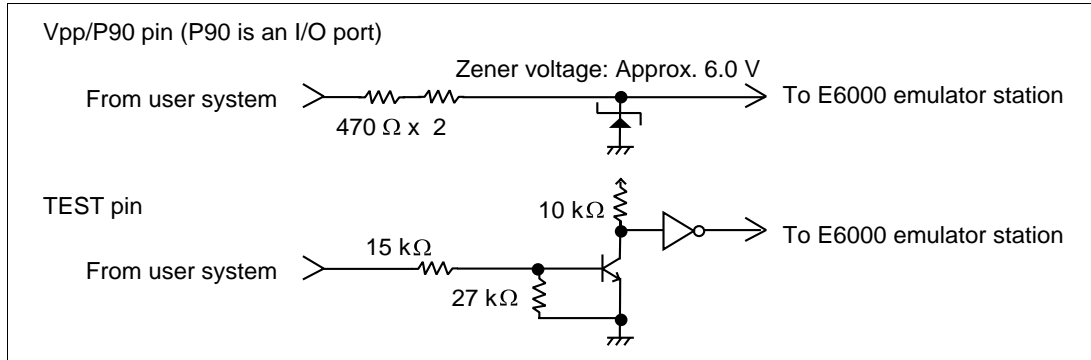

**Figure 11 Vpp/P90 and TEST Pin Protection Circuits**

7. The P1 short connector is used for testing. Do not remove the inserted jumper pin.

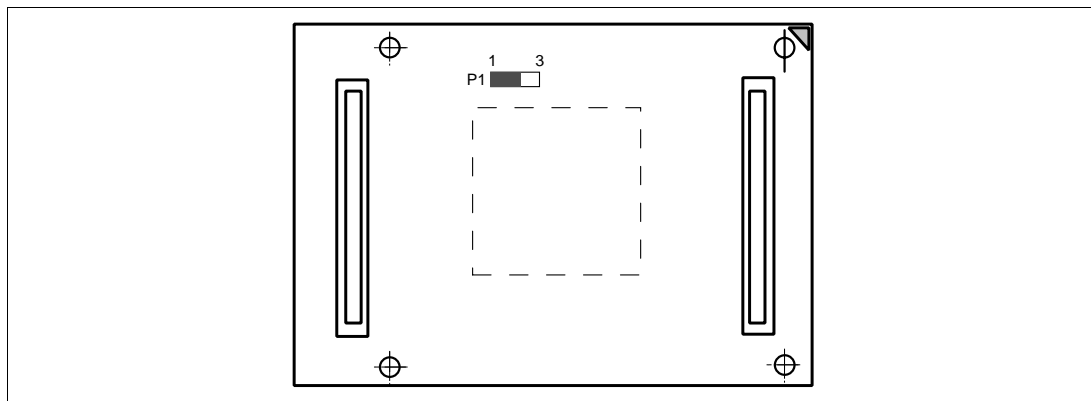

**Figure 12 P1 Short Connector**