

# RA6M3 Group

Graphics Evaluation Kit for RA6M3 Microcontroller  
Group  
EK-RA6M3G v1  
User's Manual

Renesas RA Family  
RA6 Series

All information contained in these materials, including products and product specifications, represents information on the product at the time of publication and is subject to change by Renesas Electronics Corp. without notice. Please review the latest information published by Renesas Electronics Corp. through various means, including the Renesas Electronics Corp. website (<https://www.renesas.com>).

## Notice

1. Descriptions of circuits, software and other related information in this document are provided only to illustrate the operation of semiconductor products and application examples. You are fully responsible for the incorporation or any other use of the circuits, software, and information in the design of your product or system. Renesas Electronics disclaims any and all liability for any losses and damages incurred by you or third parties arising from the use of these circuits, software, or information.
2. Renesas Electronics hereby expressly disclaims any warranties against and liability for infringement or any other claims involving patents, copyrights, or other intellectual property rights of third parties, by or arising from the use of Renesas Electronics products or technical information described in this document, including but not limited to, the product data, drawings, charts, programs, algorithms, and application examples.
3. No license, express, implied or otherwise, is granted hereby under any patents, copyrights or other intellectual property rights of Renesas Electronics or others.
4. You shall be responsible for determining what licenses are required from any third parties, and obtaining such licenses for the lawful import, export, manufacture, sales, utilization, distribution or other disposal of any products incorporating Renesas Electronics products, if required.
5. You shall not alter, modify, copy, or reverse engineer any Renesas Electronics product, whether in whole or in part. Renesas Electronics disclaims any and all liability for any losses or damages incurred by you or third parties arising from such alteration, modification, copying or reverse engineering.
6. Renesas Electronics products are classified according to the following two quality grades: "Standard" and "High Quality". The intended applications for each Renesas Electronics product depends on the product's quality grade, as indicated below.

"Standard": Computers; office equipment; communications equipment; test and measurement equipment; audio and visual equipment; home electronic appliances; machine tools; personal electronic equipment; industrial robots; etc.

"High Quality": Transportation equipment (automobiles, trains, ships, etc.); traffic control (traffic lights); large-scale communication equipment; key financial terminal systems; safety control equipment; etc.

Unless expressly designated as a high reliability product or a product for harsh environments in a Renesas Electronics data sheet or other Renesas Electronics document, Renesas Electronics products are not intended or authorized for use in products or systems that may pose a direct threat to human life or bodily injury (artificial life support devices or systems; surgical implantations; etc.), or may cause serious property damage (space system; undersea repeaters; nuclear power control systems; aircraft control systems; key plant systems; military equipment; etc.). Renesas Electronics disclaims any and all liability for any damages or losses incurred by you or any third parties arising from the use of any Renesas Electronics product that is inconsistent with any Renesas Electronics data sheet, user's manual or other Renesas Electronics document.
7. No semiconductor product is absolutely secure. Notwithstanding any security measures or features that may be implemented in Renesas Electronics hardware or software products, Renesas Electronics shall have absolutely no liability arising out of any vulnerability or security breach, including but not limited to any unauthorized access to or use of a Renesas Electronics product or a system that uses a Renesas Electronics product. RENESAS ELECTRONICS DOES NOT WARRANT OR GUARANTEE THAT RENESAS ELECTRONICS PRODUCTS, OR ANY SYSTEMS CREATED USING RENESAS ELECTRONICS PRODUCTS WILL BE INVULNERABLE OR FREE FROM CORRUPTION, ATTACK, VIRUSES, INTERFERENCE, HACKING, DATA LOSS OR THEFT, OR OTHER SECURITY INTRUSION ("Vulnerability Issues"). RENESAS ELECTRONICS DISCLAIMS ANY AND ALL RESPONSIBILITY OR LIABILITY ARISING FROM OR RELATED TO ANY VULNERABILITY ISSUES. FURTHERMORE, TO THE EXTENT PERMITTED BY APPLICABLE LAW, RENESAS ELECTRONICS DISCLAIMS ANY AND ALL WARRANTIES, EXPRESS OR IMPLIED, WITH RESPECT TO THIS DOCUMENT AND ANY RELATED OR ACCOMPANYING SOFTWARE OR HARDWARE, INCLUDING BUT NOT LIMITED TO THE IMPLIED WARRANTIES OF MERCHANTABILITY, OR FITNESS FOR A PARTICULAR PURPOSE.
8. When using Renesas Electronics products, refer to the latest product information (data sheets, user's manuals, application notes, "General Notes for Handling and Using Semiconductor Devices" in the reliability handbook, etc.), and ensure that usage conditions are within the ranges specified by Renesas Electronics with respect to maximum ratings, operating power supply voltage range, heat dissipation characteristics, installation, etc. Renesas Electronics disclaims any and all liability for any malfunctions, failure or accident arising out of the use of Renesas Electronics products outside of such specified ranges.
9. Although Renesas Electronics endeavors to improve the quality and reliability of Renesas Electronics products, semiconductor products have specific characteristics, such as the occurrence of failure at a certain rate and malfunctions under certain use conditions. Unless designated as a high reliability product or a product for harsh environments in a Renesas Electronics data sheet or other Renesas Electronics document, Renesas Electronics products are not subject to radiation resistance design. You are responsible for implementing safety measures to guard against the possibility of bodily injury, injury or damage caused by fire, and/or danger to the public in the event of a failure or malfunction of Renesas Electronics products, such as safety design for hardware and software, including but not limited to redundancy, fire control and malfunction prevention, appropriate treatment for aging degradation or any other appropriate measures. Because the evaluation of microcomputer software alone is very difficult and impractical, you are responsible for evaluating the safety of the final products or systems manufactured by you.
10. Please contact a Renesas Electronics sales office for details as to environmental matters such as the environmental compatibility of each Renesas Electronics product. You are responsible for carefully and sufficiently investigating applicable laws and regulations that regulate the inclusion or use of controlled substances, including without limitation, the EU RoHS Directive, and using Renesas Electronics products in compliance with all these applicable laws and regulations. Renesas Electronics disclaims any and all liability for damages or losses occurring as a result of your noncompliance with applicable laws and regulations.
11. Renesas Electronics products and technologies shall not be used for or incorporated into any products or systems whose manufacture, use, or sale is prohibited under any applicable domestic or foreign laws or regulations. You shall comply with any applicable export control laws and regulations promulgated and administered by the governments of any countries asserting jurisdiction over the parties or transactions.
12. It is the responsibility of the buyer or distributor of Renesas Electronics products, or any other party who distributes, disposes of, or otherwise sells or transfers the product to a third party, to notify such third party in advance of the contents and conditions set forth in this document.
13. This document shall not be reprinted, reproduced or duplicated in any form, in whole or in part, without prior written consent of Renesas Electronics.
14. Please contact a Renesas Electronics sales office if you have any questions regarding the information contained in this document or Renesas Electronics products.

(Note1) "Renesas Electronics" as used in this document means Renesas Electronics Corporation and also includes its directly or indirectly controlled subsidiaries.

(Note2) "Renesas Electronics product(s)" means any product developed or manufactured by or for Renesas Electronics.

(Rev.5.0-1 October 2020)

## Corporate Headquarters

TOYOSU FORESIA, 3-2-24 Toyosu,  
Koto-ku, Tokyo 135-0061, Japan  
[www.renesas.com](http://www.renesas.com)

## Trademarks

Renesas and the Renesas logo are trademarks of Renesas Electronics Corporation. All trademarks and registered trademarks are the property of their respective owners.

## Contact information

For further information on a product, technology, the most up-to-date version of a document, or your nearest sales office, please visit:  
[www.renesas.com/contact/](http://www.renesas.com/contact/).

# General Precautions in the Handling of Microprocessing Unit and Microcontroller Unit Products

The following usage notes are applicable to all Microprocessing unit and Microcontroller unit products from Renesas. For detailed usage notes on the products covered by this document, refer to the relevant sections of the document as well as any technical updates that have been issued for the products.

## 1. Precaution against Electrostatic Discharge (ESD)

A strong electrical field, when exposed to a CMOS device, can cause destruction of the gate oxide and ultimately degrade the device operation. Steps must be taken to stop the generation of static electricity as much as possible, and quickly dissipate it when it occurs. Environmental control must be adequate. When it is dry, a humidifier should be used. This is recommended to avoid using insulators that can easily build up static electricity. Semiconductor devices must be stored and transported in an anti-static container, static shielding bag or conductive material. All test and measurement tools including work benches and floors must be grounded. The operator must also be grounded using a wrist strap. Semiconductor devices must not be touched with bare hands. Similar precautions must be taken for printed circuit boards with mounted semiconductor devices.

## 2. Processing at power-on

The state of the product is undefined at the time when power is supplied. The states of internal circuits in the LSI are indeterminate and the states of register settings and pins are undefined at the time when power is supplied. In a finished product where the reset signal is applied to the external reset pin, the states of pins are not guaranteed from the time when power is supplied until the reset process is completed. In a similar way, the states of pins in a product that is reset by an on-chip power-on reset function are not guaranteed from the time when power is supplied until the power reaches the level at which resetting is specified.

## 3. Input of signal during power-off state

Do not input signals or an I/O pull-up power supply while the device is powered off. The current injection that results from input of such a signal or I/O pull-up power supply may cause malfunction and the abnormal current that passes in the device at this time may cause degradation of internal elements. Follow the guideline for input signal during power-off state as described in your product documentation.

## 4. Handling of unused pins

Handle unused pins in accordance with the directions given under handling of unused pins in the manual. The input pins of CMOS products are generally in the high-impedance state. In operation with an unused pin in the open-circuit state, extra electromagnetic noise is induced in the vicinity of the LSI, an associated shoot-through current flows internally, and malfunctions occur due to the false recognition of the pin state as an input signal become possible.

## 5. Clock signals

After applying a reset, only release the reset line after the operating clock signal becomes stable. When switching the clock signal during program execution, wait until the target clock signal is stabilized. When the clock signal is generated with an external resonator or from an external oscillator during a reset, ensure that the reset line is only released after full stabilization of the clock signal. Additionally, when switching to a clock signal produced with an external resonator or by an external oscillator while program execution is in progress, wait until the target clock signal is stable.

## 6. Voltage application waveform at input pin

Waveform distortion due to input noise or a reflected wave may cause malfunction. If the input of the CMOS device stays in the area between  $V_{IL}$  (Max.) and  $V_{IH}$  (Min.) due to noise, for example, the device may malfunction. Take care to prevent chattering noise from entering the device when the input level is fixed, and also in the transition period when the input level passes through the area between  $V_{IL}$  (Max.) and  $V_{IH}$  (Min.).

## 7. Prohibition of access to reserved addresses

Access to reserved addresses is prohibited. The reserved addresses are provided for possible future expansion of functions. Do not access these addresses as the correct operation of the LSI is not guaranteed.

## 8. Differences between products

Before changing from one product to another, for example to a product with a different part number, confirm that the change will not lead to problems. The characteristics of a microprocessing unit or microcontroller unit products in the same group but having a different part number might differ in terms of internal memory capacity, layout pattern, and other factors, which can affect the ranges of electrical characteristics, such as characteristic values, operating margins, immunity to noise, and amount of radiated noise. When changing to a product with a different part number, implement a system-evaluation test for the given product.

## Renesas EK-RA6M3G Disclaimer

By using this EK-RA6M3G, the User accepts the following terms, which are in addition to, and control in the event of disagreement, with Renesas' General Terms and Conditions available at [renesas.com/legal-notices](https://www.renesas.com/legal-notices).

The EK-RA6M3G is not guaranteed to be error free, and the entire risk as to the results and performance of the EK-RA6M3G is assumed by the User. The EK-RA6M3G is provided by Renesas on an "as is" basis without warranty of any kind whether express or implied, including but not limited to the implied warranties of good workmanship, fitness for a particular purpose, title, merchantability, and non-infringement of intellectual property rights. Renesas expressly disclaims any implied warranty.

Renesas does not consider the EK-RA6M3G to be a finished product and therefore the EK-RA6M3G may not comply with some requirements applicable to finished products, including, but not limited to recycling, restricted substances and electromagnetic compatibility regulations. Refer to Certifications section, for information about certifications and compliance information for the EK-RA6M3G. It is the kit User's responsibility to make sure the kit meets any local requirements applicable to their region.

Renesas or its affiliates shall in no event be liable for any loss of profit, loss of data, loss of contract, loss of business, damage to reputation or goodwill, any economic loss, any reprogramming or recall costs (whether the foregoing losses are direct or indirect) nor shall Renesas or its affiliates be liable for any other direct or indirect special, incidental or consequential damages arising out of or in relation to the use of this EK-RA6M3G, even if Renesas or its affiliates have been advised of the possibility of such damages.

Renesas has used reasonable care in preparing the information included in this document, but Renesas does not warrant that such information is error free nor does Renesas guarantee an exact match for every application or parameter to part numbers designated by other vendors listed herein. The information provided in this document is intended solely to enable the use of Renesas products. No express or implied license to any intellectual property right is granted by this document or in connection with the sale of Renesas products. Renesas reserves the right to make changes to specifications and product descriptions at any time without notice. Renesas assumes no liability for any damages incurred by you resulting from errors in or omissions from the information included herein. Renesas cannot verify, and assumes no liability for, the accuracy of information available on another company's website.

## Precautions

This Evaluation Kit is only intended for use in a laboratory environment under ambient temperature and humidity conditions. A safe separation distance should be used between this and any sensitive equipment. Its use outside the laboratory, classroom, study area, or similar such area invalidates conformity with the protection requirements of the Electromagnetic Compatibility Directive and could lead to prosecution.

The product generates, uses, and can radiate radio frequency energy and may cause harmful interference to radio communications. There is no guarantee that interference will not occur in a particular installation. If this equipment causes harmful interference to radio or television reception, which can be determined by turning the equipment off or on, you are encouraged to try to correct the interference by one or more of the following measures:

- Ensure attached cables do not lie across the equipment.
- Reorient the receiving antenna.
- Increase the distance between the equipment and the receiver.
- Connect the equipment into an outlet on a circuit different from that which the receiver is connected.
- Power down the equipment when not in use.
- Consult the dealer or an experienced radio/TV technician for help.

Note: It is recommended that wherever possible shielded interface cables are used.

The product is potentially susceptible to certain EMC phenomena. To mitigate against them it is recommended that the following measures be undertaken:

- The user is advised that mobile phones should not be used within 10 m of the product when in use.
- The user is advised to take ESD precautions when handling the equipment.

The Evaluation Kit does not represent an ideal reference design for an end product and does not fulfill the regulatory standards for an end product.

## Renesas RA Family

**EK-RA6M3G v1****Contents**

1. Kit Overview.....	4
1.1 Assumptions and Advisory Notes.....	7
2. Kit Contents .....	8
3. Ordering Information.....	9
4. Hardware Architecture and Default Configuration .....	9
4.1 Kit Architecture .....	9
4.2 EK-RA6M3 Board Architecture.....	9
4.3 Graphics Expansion Board Architecture.....	10
4.4 System Block Diagram .....	11
4.5 Jumper Settings .....	11
4.5.1 Copper Jumpers.....	11
4.5.2 Traditional Pin Header Jumpers.....	12
4.5.3 Default Jumper Configuration.....	12
5. EK-RA6M3 Board System Control and Ecosystem Access Area .....	13
5.1 Power .....	14
5.1.1 Power Supply Options.....	14
5.1.2 Power Supply Considerations .....	15
5.1.3 Power-up Behavior.....	15
5.2 Debug and Trace.....	15
5.2.1 Debug On-Board .....	16
5.2.2 Debug In.....	17
5.2.3 Debug Out.....	18
5.3 Ecosystem.....	19
5.3.1 Seeed Grove® Connectors .....	19
5.3.2 Digilent Pmod™ Connectors .....	19
5.3.3 Arduino™ Connector.....	21
5.3.4 MikroElektronika™ mikroBUS Connector.....	22
5.4 Connectivity.....	23
5.4.1 USB Full Speed.....	23
5.5 Miscellaneous.....	24
5.5.1 User and Power LEDs.....	24
5.5.2 User and Reset Switches .....	24
5.5.3 MCU Boot Mode.....	25

6.	EK-RA6M3 Board Special Feature Access Area.....	25
6.1	Ethernet.....	25
6.2	USB High Speed .....	26
6.3	QSPI Flash.....	27
7.	EK-RA6M3 Board MCU Native Pin Access Area .....	28
7.1	Breakout Pin Headers .....	28
7.2	MCU and USB Current Measurement.....	28
8.	Graphics Expansion Board.....	29
8.1	Connecting the Graphics Expansion Board on to EK-RA6M3 Board .....	30
8.2	Signal Assignment.....	30
9.	Certifications .....	32
9.1	EMC/EMI Standards.....	32
9.2	Material Selection, Waste, Recycling and Disposal Standards .....	32
9.3	Safety Standards.....	33
10.	Design and Manufacturing Information .....	34
11.	Website and Support.....	34
	Revision History .....	35

## Figures

Figure 1.	EK-RA6M3 Board Top Side.....	5
Figure 2.	EK-RA6M3 Board Bottom Side .....	6
Figure 3.	Graphics Expansion Board Top Side .....	7
Figure 4.	Graphics Expansion Board Bottom Side .....	7
Figure 5.	EK-RA6M3G Kit Contents .....	8
Figure 6.	EK-RA6M3 Board Functional Area Definitions .....	10
Figure 7.	EK-RA6M3G Kit Block Diagram .....	11
Figure 8.	Copper Jumpers.....	12
Figure 9.	System Control and Ecosystem Access Area .....	14
Figure 10.	Power Supply Options .....	14
Figure 11.	EK-RA6M3 Board Debug Interface .....	17
Figure 12.	Seeed Grove Connectors.....	19
Figure 13.	PMOD 1.....	20
Figure 14.	PMOD 2.....	21
Figure 15.	Arduino Uno Connectors .....	22
Figure 16.	mikroBus Connection .....	23
Figure 17.	USB Full Speed Connector .....	23
Figure 18.	User LEDs .....	24
Figure 19.	Power LED .....	24

Figure 20. Reset and User Switches .....	25
Figure 21. Boot Mode .....	25
Figure 22. Special Features Access Area .....	25
Figure 23. Ethernet Connector .....	26
Figure 24. USB High Speed Connector.....	27
Figure 25. QSPI Flash .....	27
Figure 26. Native Pin Access Area .....	28
Figure 27. RA MCU USB Current Measurement Circuit.....	29
Figure 28. RA MCU +3.3 V Current Measurement Circuit.....	29
Figure 29. RA MCU Current Measurement .....	29
Figure 30. Aligning Graphics Expansion Board and the EK-RA6M3 Board Using the Alignment Arrows Printed on the Bottom of Each Board .....	30
Figure 31. Aligning Graphics Expansion Board and the EK-RA6M3 Board Using the Alignment Triangles Printed on the Top of Each Board .....	30

## Tables

Table 1. Default Jumper Settings .....	12
Table 2. Debug Modes .....	15
Table 3. Jumper Connection Summary for Different Debug Modes .....	16
Table 4. Debug USB Connector .....	16
Table 5. Debug On-Board Mode Jumper Configuration .....	16
Table 6. Debug In Mode Jumper Configuration.....	17
Table 7. JTAG/SWD/TRACE Connector .....	17
Table 8. JTAG/SWD Connector.....	18
Table 9. Debug Out Mode Jumper Configuration .....	18
Table 10. Grove 1 Connector.....	19
Table 11. Grove 2 Connector.....	19
Table 12. PMOD 1 Connector.....	20
Table 13. PMOD 2 Connector.....	20
Table 14. Arduino Uno Connections .....	21
Table 15. mikroBus Connections .....	22
Table 16. USB Full Speed Connector .....	23
Table 17. EK-RA6M3 Board LED Functions .....	24
Table 18. EK-RA6M3 Board Switches .....	24
Table 19. Ethernet Port Assignments .....	26
Table 20. Ethernet Components .....	26
Table 21. USB High Speed Connector .....	27
Table 22. QSPI Flash Port Assignments.....	27
Table 23. Graphics Expansion Connector Signals.....	31
Table 24. EK-RA6M3 Board Design Package Contents .....	34

## 1. Kit Overview

The EK-RA6M3G, Graphics Evaluation Kit for RA6M3 MCU Group, enables users to seamlessly evaluate the features of the RA6M3 MCU group and develop embedded systems applications using Flexible Software Package (FSP) and e<sup>2</sup> studio IDE. The users can utilize rich on-board features along with their choice of popular ecosystems add-ons to bring their big ideas to life.

The EK-RA6M3G kit consists of two boards: the EK-RA6M3 board featuring the RA6M3 MCU with on-chip Graphics LCD Controller and the Graphics Expansion Board featuring a 4.3 inch TFT color LCD with capacitive touch overlay.

The key features of the EK-RA6M3 board are categorized in three groups (consistent with the architecture of the kit) as follows:

### MCU Native Pin Access

- R7FA6M3AH3CFC MCU (referred to as RA MCU)
- 120 MHz, Arm<sup>®</sup> Cortex<sup>®</sup>-M4 core
- 2 MB Code Flash, 640 KB SRAM
- 176 pins, LQFP package
- Native pin access through 4 x 40-pin male headers
- MCU and USB current measurement points for precision current consumption measurement
- Multiple clock sources - RA MCU oscillator and sub-clock oscillator crystals, providing precision 24.000 MHz and 32,768 Hz reference clock. Additional low-precision clocks are available internal to the RA MCU.

### System Control and Ecosystem Access

- USB Full Speed Host and Device (micro AB connector)
- Four 5 V input sources
  - USB (Debug, Full Speed, High Speed)
  - External power supply (using surface mount clamp test points and power input vias)
- Three Debug modes
  - Debug on-board (SWD)
  - Debug in (ETM, SWD, and JTAG)
  - Debug out (SWD)
- User LEDs and buttons
  - Three User LEDs (red, blue, green)
  - Power LED (white) indicating availability of regulated power
  - Debug LED (yellow) indicating the debug connection
  - Two User buttons
  - One Reset button
- Four most popular ecosystems expansions
  - 2 SeeedGrove<sup>®</sup> system (I2C) connectors
  - 2 Digilent Pmod<sup>™</sup> (SPI and UART) connectors
  - Arduino<sup>™</sup> (Uno R3) connector
  - MikroElektronika<sup>™</sup> mikroBUS connector
- MCU boot configuration jumper

### Special Feature Access

- Ethernet (RJ 45 RMII interface)
- USB High Speed Host and Device (micro AB connector)
- 32 MB (256 Mb) External QSPI Flash

The key features of the Graphics Expansion Board are as follows:

- 4.3 inch TFT color LCD
  - 480 x 272 resolution
  - Capacitive touch overlay with controller
- Back light controller

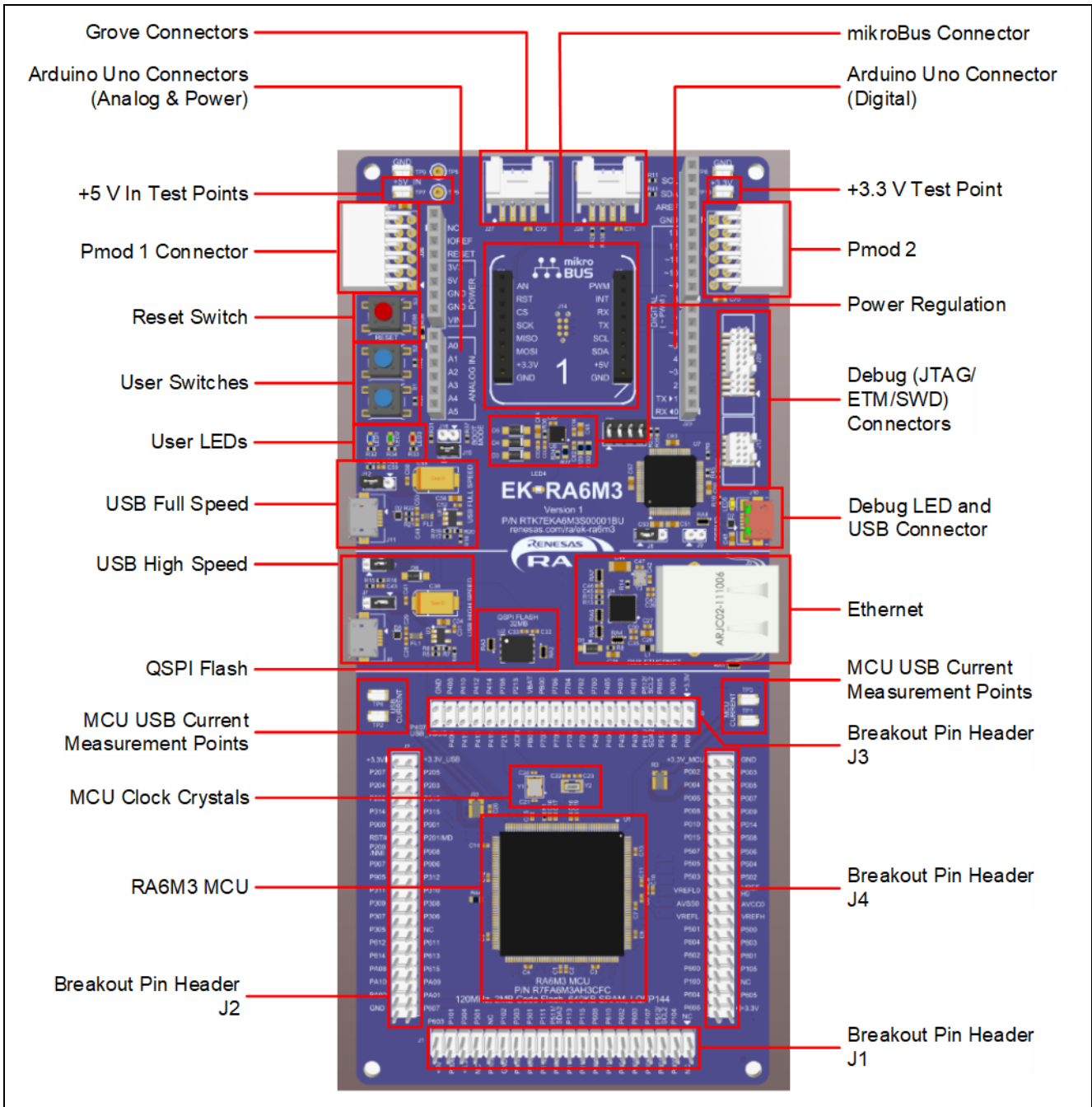

Figure 1. EK-RA6M3 Board Top Side

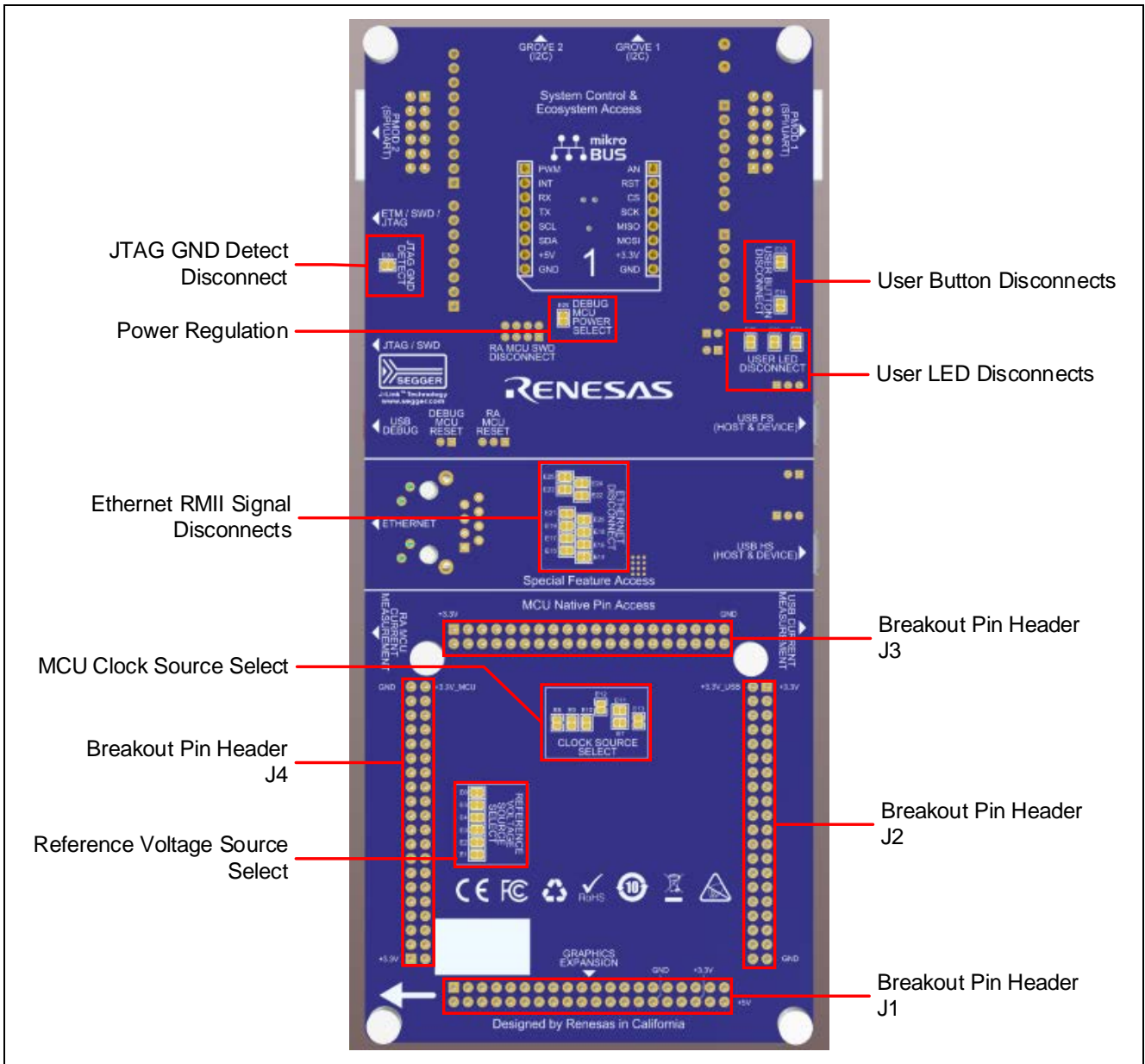

Figure 2. EK-RA6M3 Board Bottom Side

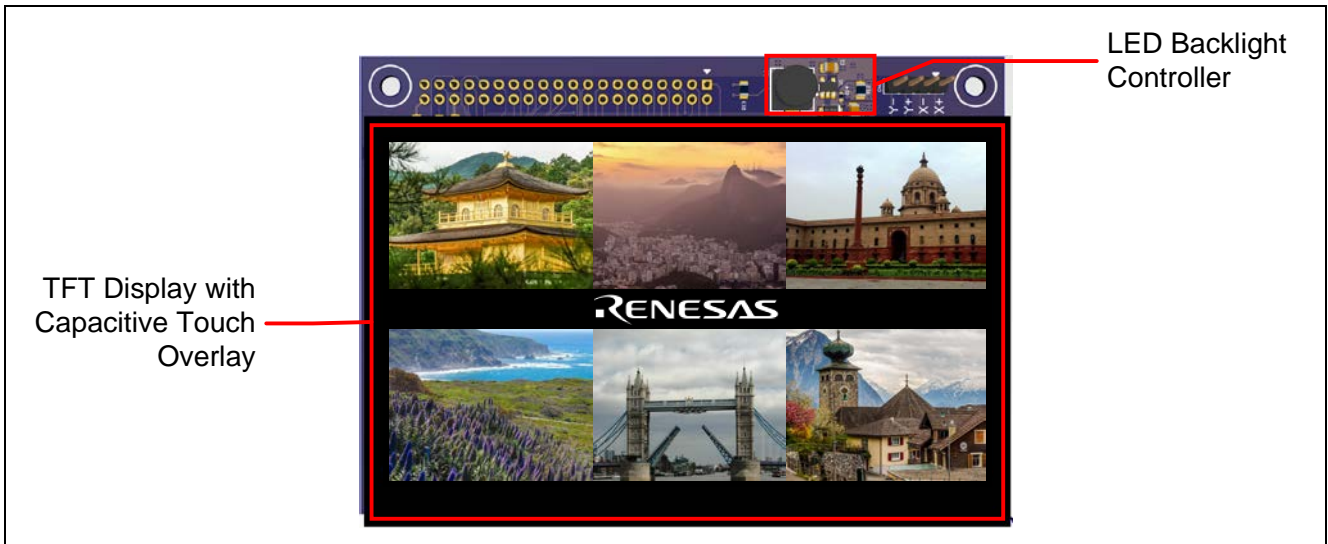

Figure 3. Graphics Expansion Board Top Side

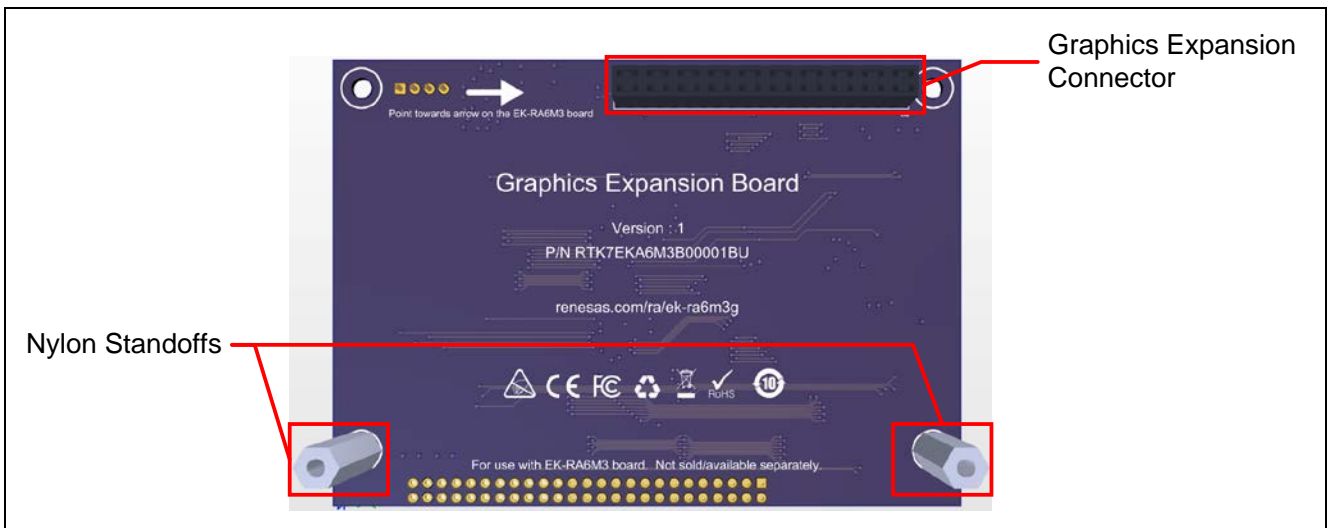

Figure 4. Graphics Expansion Board Bottom Side

### 1.1 Assumptions and Advisory Notes

1. It is assumed that the user has basic understanding of microcontrollers and embedded systems hardware.
2. It is recommended that the user refers to the *EK-RA6M3G Quick Start Guide* to get acquainted with the kit and the Quick Start example project that the EK-RA6M3 board comes pre-programmed with.
3. Flexible Software Package (FSP) and IDE such as e<sup>2</sup> studio are required to develop embedded applications on the EK-RA6M3G kit.
4. Instructions to download and install software, import example projects, build them and program the EK-RA6M3G kit are provided in the quick start guide.

## 2. Kit Contents

The following components are included in the kit:

1. EK-RA6M3 v1 board
2. Graphics Expansion Board
3. Micro USB device cable (type-A male to micro-B male)
4. Micro USB host cable (type-A female to micro-B male)
5. Ethernet patch cable

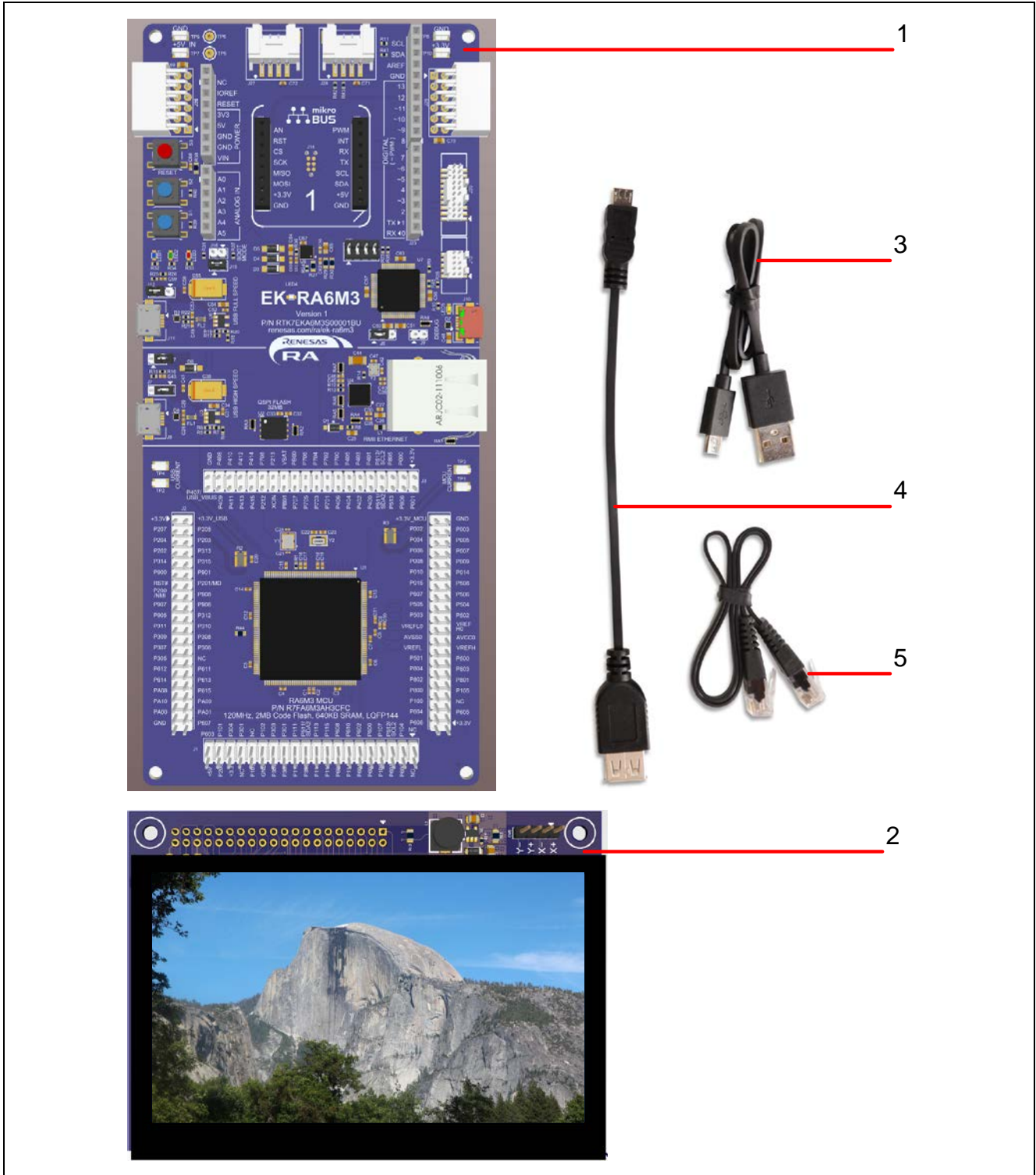

Figure 5. EK-RA6M3G Kit Contents

### 3. Ordering Information

- EK-RA6M3G v1 kit orderable part number: RTK7EKA6M3S01001BU  
Note: The underlined character in the orderable part number represents the kit version.
- EK-RA6M3 board dimensions: 80 mm (width) x 180 mm (length)
- Graphics Expansion Board dimensions: 110 mm (width) x 78.3 mm (length)

## 4. Hardware Architecture and Default Configuration

### 4.1 Kit Architecture

The EK-RA6M3G kit consists of two boards: the EK-RA6M3 board and the Graphics Expansion Board. The Graphics Expansion Board plugs on to the graphics expansion header (J1) on the EK-RA6M3 board. The architecture of each of the two boards is described in the following sections.

### 4.2 EK-RA6M3 Board Architecture

The EK-RA6M3 board is designed with three sections or areas to help shorten the learning curve of the users and maximize the design and knowledge reuse among similar kits. The contents of these three areas are conceptually standardized among similar kits.

Kit area	Area features	Area present on all similar kits	Functionality is:
MCU Native Pin Access area	RA MCU, breakout pin headers for all MCU I/O and power, current measurement	Yes	MCU dependent
Special Feature Access area	MCU special features: Ethernet, USB High Speed Host and Device, QSPI	Optional	MCU dependent
System Control and Ecosystem Access area	Power, Debug MCU, User LED and buttons, reset, ecosystem connectors, USB Full Speed Host and Device, Boot configuration	Yes	Same or similar across similar kits

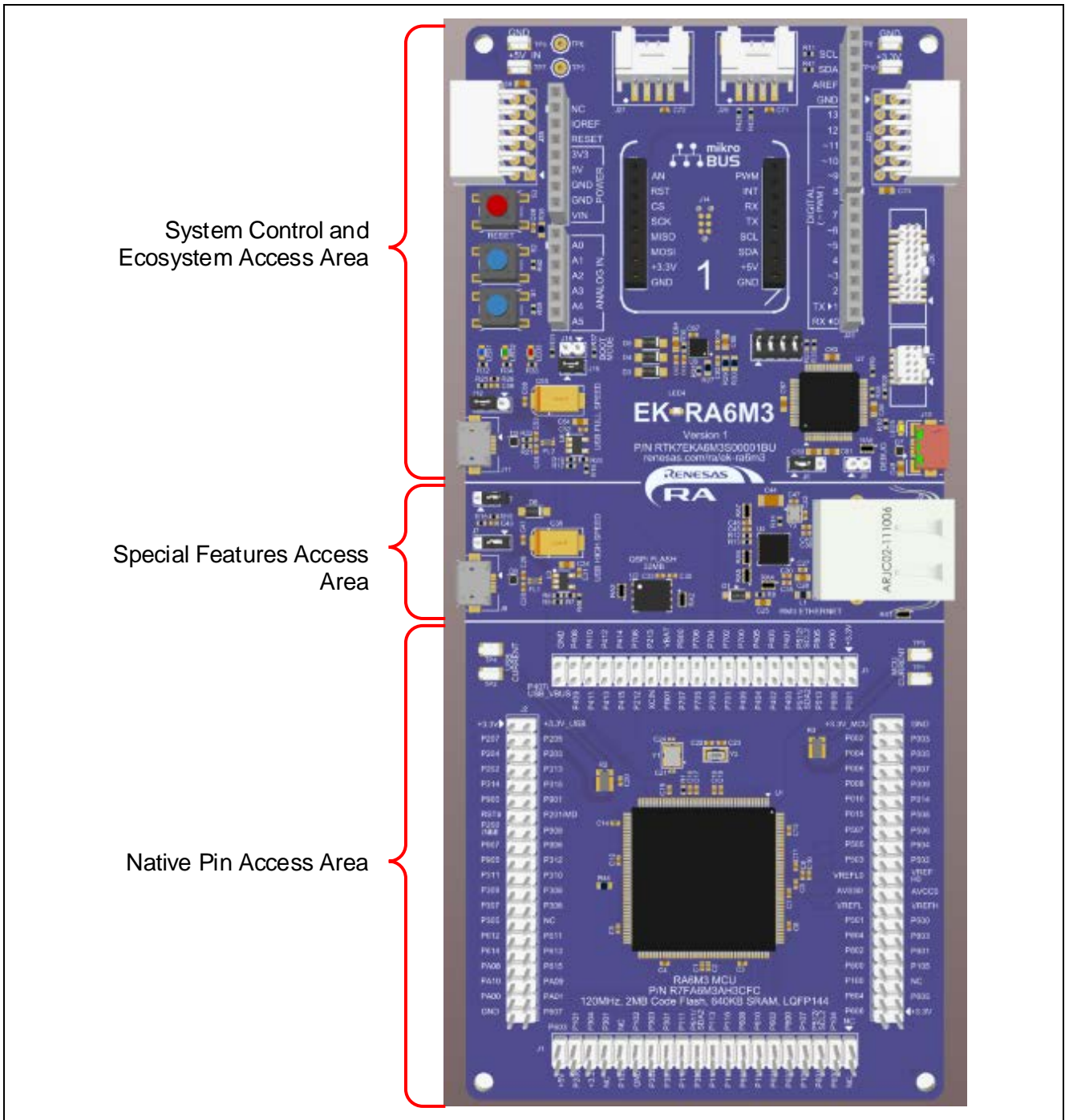

### 4.4 System Block Diagram

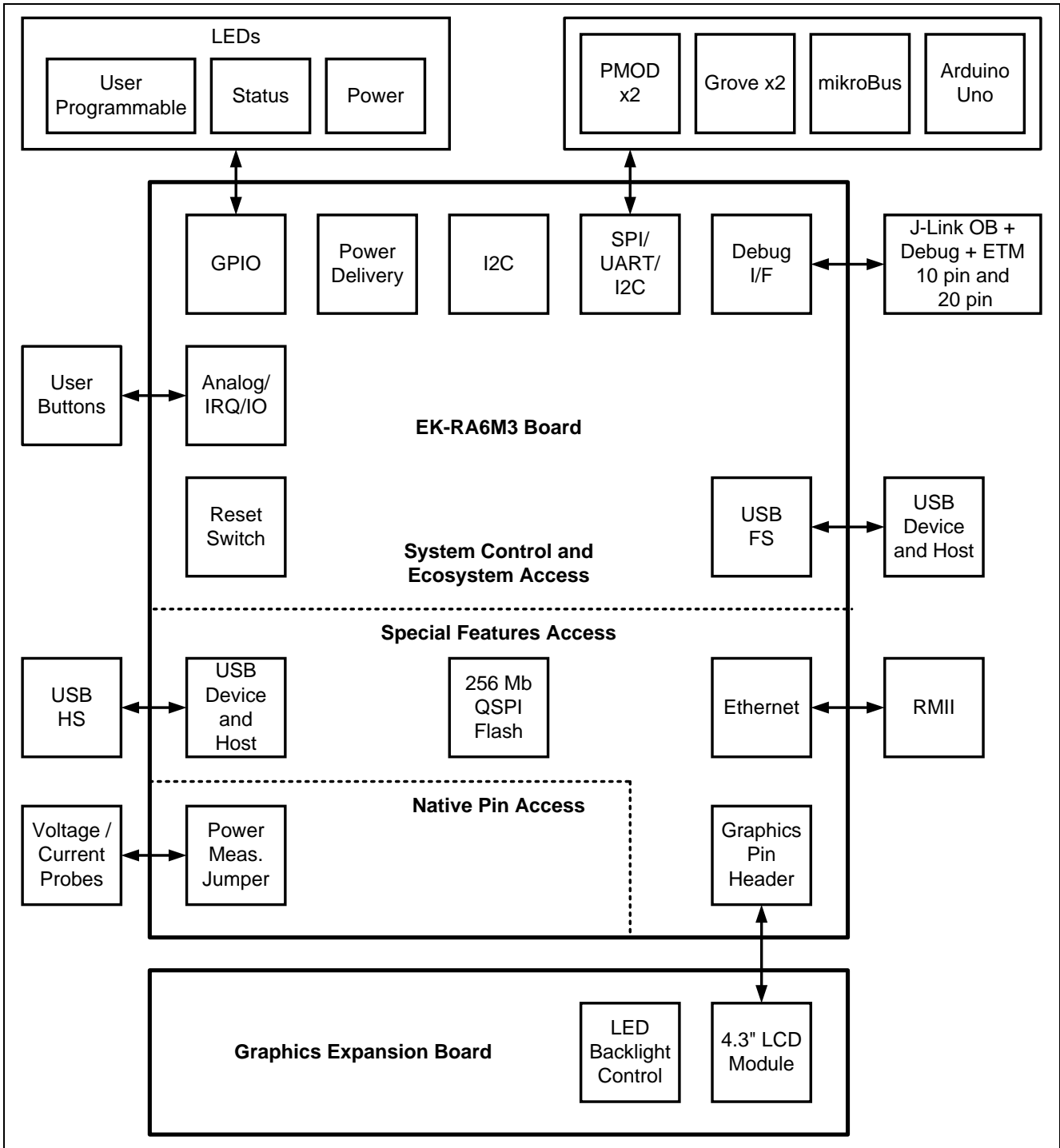

Figure 7. EK-RA6M3G Kit Block Diagram

### 4.5 Jumper Settings

Two types of jumpers are provided on the EK-RA6M3 board.

1. Copper jumpers (trace-cut type and solder bridge type).
2. Traditional pin header jumpers.

The following sections describe each type and their default configuration.

#### 4.5.1 Copper Jumpers

Copper jumpers are of two types, designated **trace-cut** and **solder-bridge**.

A **trace-cut jumper** is provided with a narrow copper trace connecting its pads. The silk screen overlay printing around a trace-cut jumper is a solid box. To isolate the pads, cut the trace between pads adjacent to each pad, then remove the connecting copper foil either mechanically or with the assistance of heat. Once the etched copper trace is removed, the trace-cut jumper is turned into a solder-bridge jumper for any later changes.

A **solder-bridge** jumper is provided with two isolated pads that may be joined together by one of three methods:

- Solder may be applied to both pads to develop a bulge on each and the bulges joined by touching a soldering iron across the two pads.
- A small wire may be placed across the two pads and soldered in place.
- A SMT resistor, size 0805, 0603, or 0402, may be placed across the two pads and soldered in place. A zero-ohm resistor shorts the pads together.

The silk screen overlay printing around a solder-bridge jumper is a box with a gap in the lines adjacent to the isolation region between the pads.

For any copper jumper, the connection is considered **closed** if there is an electrical connection between the pads (default for trace-cut jumpers.) The connection is considered **open** if there is no electrical connection between the pads (default for the solder-bridge jumpers.)

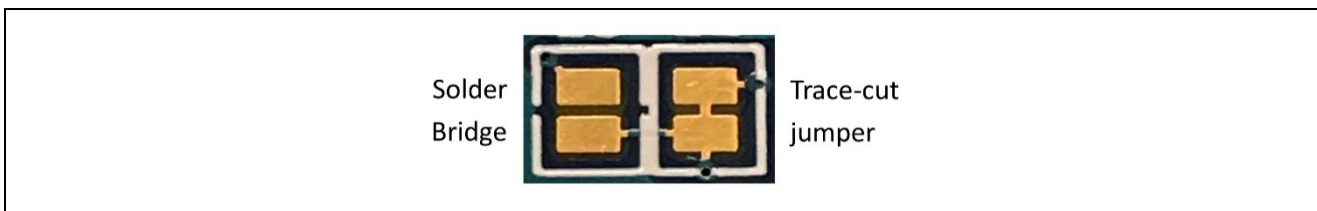

Figure 8. Copper Jumpers

#### 4.5.2 Traditional Pin Header Jumpers

These jumpers are traditional small pitch jumpers that require an external shunt to open/close them. The traditional pin jumpers on the EK-RA6M3 board are 2 mm pitch headers and require compatible 2 mm shunt jumpers.

#### 4.5.3 Default Jumper Configuration

The following table describes the default settings for each jumper on the EK-RA6M3 board. This includes copper jumpers (Ex designation) and traditional pin jumpers (Jx designation.)

The Circuit Group for each jumper is the designation found in the board schematic (available in the Design Package). Functional details for many of the listed jumpers may be found in sections associated with each functional area of the kits.

Table 1. Default Jumper Settings

Location	Circuit Group	Default Open/Closed	Function
J7	USB HS	Jumper on pins 1-2	Sets USB power to host mode
J8	J-Link OB	Jumper on pins 1-2	Configures J-Link OB as the on-board debugger
J9	J-Link OB	Open	Configures Reset# for on-board debugger mode
J12	USB FS	Jumper on pins 2-3	Sets USB power to device mode
J15	USB FS	Jumper on pins 1-2	Connects micro-USB power to system power
J16	MCU Boot Mode	Open	Configures the MCU for normal boot mode
J17	USB HS	Open	Connects micro-USB power to system power
J29	J-Link OB	Jumper on pins 1-2 Jumper on pins 3-4 Jumper on pins 5-6 Jumper on pins 7-8	Connects the J-Link OB debugger to the RA MCU
E1	MCU Power	Closed	Connects VREFL to GND
E2	MCU Power	Closed	Connects VREFH to +3.3 V
E3	MCU Power	Closed	Connects AVCC0 to +3.3 V

Location	Circuit Group	Default Open/Closed	Function
E4	MCU Power	Closed	Connects AVSS0 to GND
E5	MCU Power	Closed	Connects VREFL0 to GND
E6	MCU Power	Closed	Connects VREFH0 to +3.3 V
E7	MCU Clock	Closed	Connects 24 MHz crystal to MCU EXTAL pin
E8	MCU Clock	Open	Connects MCU XCIN pin to pin headers
E9	MCU Clock	Closed	Connects 32.768 kHz crystal to MCU XCIN pin
E10	MCU Clock	Closed	Connects 32.768 kHz crystal to MCU XCOU pin
E11	MCU Clock	Closed	Connects 24 MHz crystal to MCU XTAL pin
E12	MCU Clock	Open	Connects MCU P213/XTAL pin to pin headers
E13	MCU Clock	Open	Connects MCU P212/EXTAL pin to pin headers
E14	Ethernet	Closed	Connects Ethernet RESET# to MCU P404
E15	Ethernet	Closed	Connects Ethernet TXD1 to MCU P406
E16	Ethernet	Closed	Connects Ethernet TXD0 to MCU P700
E17	Ethernet	Closed	Connects Ethernet TXD_EN to MCU P405
E18	Ethernet	Closed	Connects Ethernet IRQ to MCU P706 (IRQ7)
E19	Ethernet	Closed	Connects Ethernet RX_ER to MCU P704
E20	Ethernet	Closed	Connects Ethernet CRS_DV to MCU P705
E21	Ethernet	Closed	Connects Ethernet REF50CK0 to MCU P701
E22	Ethernet	Closed	Connects Ethernet RXD0 to MCU P702
E23	Ethernet	Closed	Connects Ethernet RXD1 to MCU P703
E24	Ethernet	Closed	Connects Ethernet MDC to MCU P401
E25	Ethernet	Closed	Connects Ethernet MDIO to MCU P402
E26	User LED	Closed	Connects User LED2 to MCU P400
E27	User LED	Closed	Connects User LED1 to MCU P403
E28	User LED	Closed	Connects User LED3 to MCU P100
E29	Debug MCU Power	Closed	Connects the Debug MCU power to +3.3 V
E30	JTAG	Closed	Connects the JTAG GND Detect pin on J20 and J13 to GND
E31	User Switch	Closed	Connects User Switch S1 to MCU P009
E32	User Switch	Closed	Connects User Switch S2 to MCU P008

## 5. EK-RA6M3 Board System Control and Ecosystem Access Area

The following figure shows the System Control and Ecosystem Access area on the EK-RA6M3 board. Subsequent sections detail the features and functionality provided in the area.

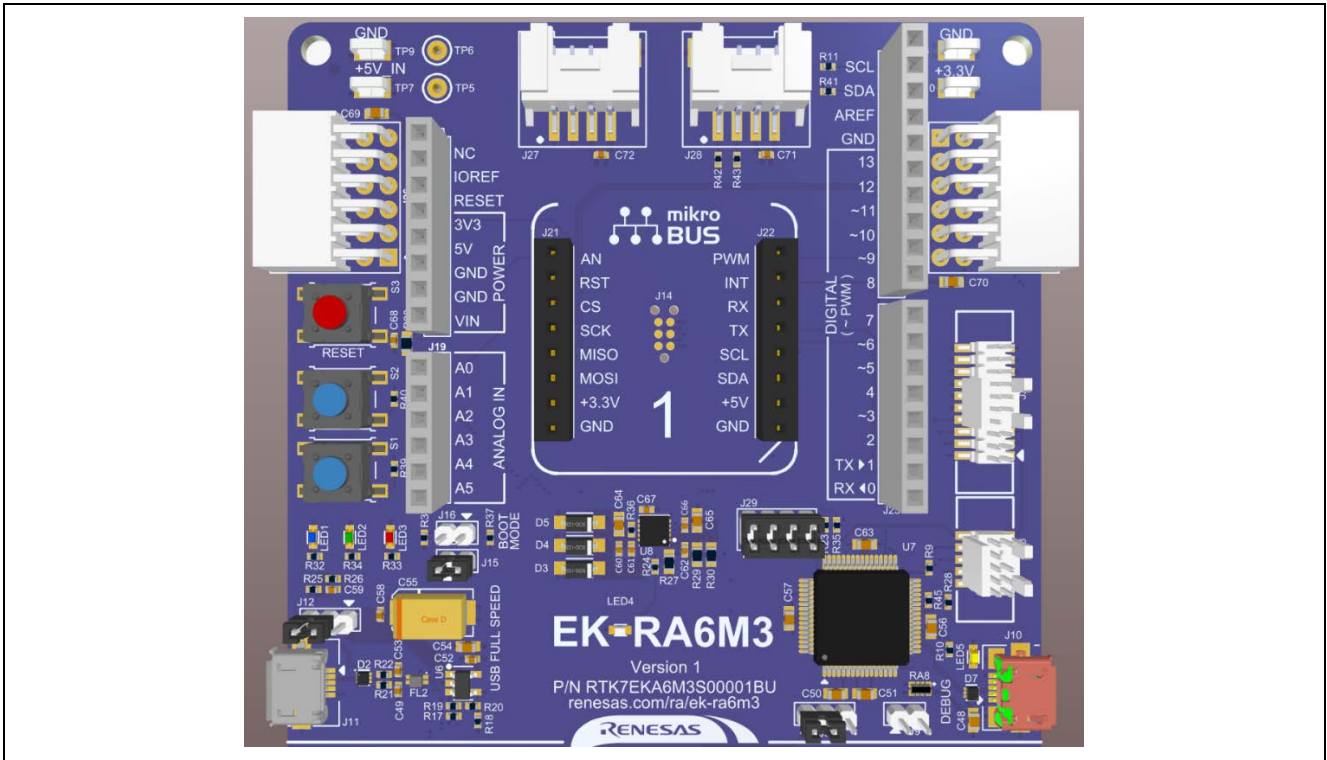

Figure 9. System Control and Ecosystem Access Area

### 5.1 Power

The EK-RA6M3G kit is designed for +5 V operation. An on-board Low Dropout Regulator (LDO) is used to convert the 5 V supply to a 3.3 V supply. The 3.3 V supply is used to power the RA MCU and other peripheral features.

#### 5.1.1 Power Supply Options

This section describes the different ways in which EK-RA6MG kit can be powered.

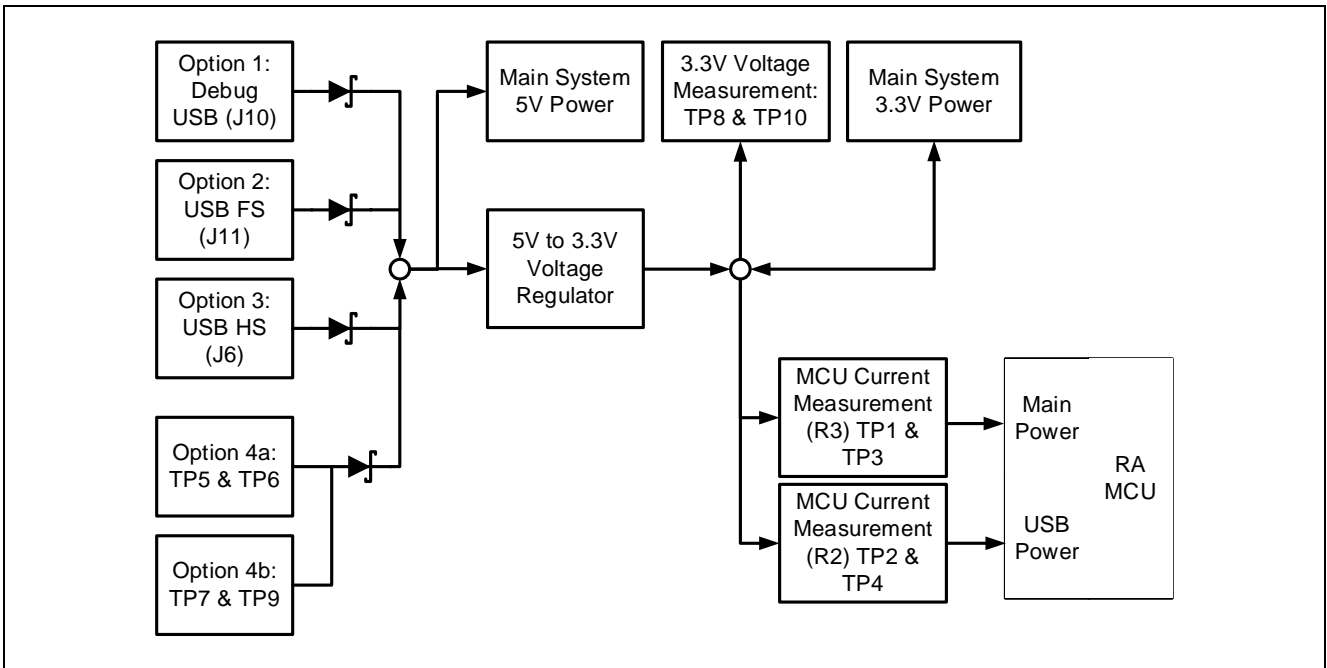

Figure 10. Power Supply Options

### 5.1.1.1 Option 1: Debug USB

5 V may be supplied from an external USB host to the USB Debug connector (J10) labelled DEBUG on the board. Power from this source is connected to the Main System 5 V Power. Reverse current protection is provided between this connector and the Main System 5 V Power.

### 5.1.1.2 Option 2: USB Full Speed

5 V may be supplied from an external USB host to the USB Full Speed connector (J11) labelled USB FULL SPEED on the board. Power from this source is connected to the Main System 5 V Power. Reverse current protection is provided between this connector and the Main System 5 V Power.

### 5.1.1.3 Option 3: USB High Speed

5 V may be supplied from an external USB host to the USB High Speed connector (J6) labelled USB HIGH SPEED on the board. Power from this source is connected to the Main System 5 V Power. Reverse current protection is provided between this connector and the Main System 5 V Power.

### 5.1.1.4 Option 4: 5V Test Points

5 V may be supplied from an external power supply to test points on the board. TP7 (5V) and TP9 (GND) are loop-style test points, and TP5 (5 V) and TP6 (GND) are large via style test points. The two types of test points are electrically equivalent, and both are provided for user convenience. Power from this source is connected to the Main System 5 V Power. Reverse current protection is provided between the 5 V test points and the Main System 5 V Power.

## 5.1.2 Power Supply Considerations

The on-board LDO regulator which supplies +3.3 V has a built-in current limit of 2.0 A. Make sure the total current required by the RA MCU, any active on-board features, and any connected peripheral devices does not exceed this limit.

Note: The total current available from a typical USB host is 500 mA maximum. Depending on the configuration of the kit, multiple power sources may be required.

## 5.1.3 Power-up Behavior

When powered, the white LED near the center of the board (the “dash” in the EK-RA6M3 name) will light up. For more details on initial power up behavior, see the *EK-RA6M3G Quick Start Guide*.

## 5.2 Debug and Trace

The EK-RA6M3 board supports the following three debug modes.

**Table 2. Debug Modes**

Debug Modes	Debugger MCU (one that connects to the IDE on PC)	Target MCU (one that is being debugged)	Debugging Interface/Protocol	Connector Used
Debug on-board	S124 (on-board)	RA6M3 (on-board)	SWD	Micro USB (J10)
Debug in	External debugging tools	RA6M3 (on-board)	SWD, ETM, JTAG	20-pin connector (J20) or 10-pin connector (J13)
Debug out	S124 (on-board)	Any external RA MCU	SWD	Micro USB (J10) plus either 20-pin connector (J20) or 10-pin connector (J13)

Notes:

- See Table 4 for the Debug USB connector pin definition.
- See Table 7 for the 20-pin JTAG connector pin definition.
- See Table 8 for the 10-pin JTAG connector pin definition.

The following table summarizes the jumper setting for each of the debug modes.

**Table 3. Jumper Connection Summary for Different Debug Modes**

Debug Modes	J8	J9	J29
Debug on-Board	Jumper on pins 1-2	Open	Jumpers on pins 1-2, 3-4, 5-6, 7-8
Debug in	Jumper on pins 1-2	Jumper on pins 1-2	Jumpers on pins 1-2, 3-4, 5-6, 7-8
Debug out	Jumper on pins 2-3	Open	All pins open

### 5.2.1 Debug On-Board

The on-board debug functionality is provided using Renesas S124 Debug MCU and SEGGER J-Link® firmware. Debug USB Micro-B connector (J10) connects the S124 Debug MCU to an external USB Full Speed Host, allowing re-programming and debugging of the target RA MCU firmware. This connection is the default debug mode for the EK-RA6M3 board.

The S124 Debug MCU connects to the target RA MCU using the SWD interface.

**Table 4. Debug USB Connector**

Debug USB Connector		EK-RA6M3
Pin	Description	Signal/Bus
J34-1	+5VDC	+5V_JUSB
J34-2	Data-	U2 USB_DM (U2-18)
J34-3	Data+	U2 USB_DP (U2-19)
J34-4	USB ID, jack internal switch, cable inserted	N.C.
J34-5	Ground	GND

A yellow indicator, LED5, shows the visual status of the debug interface. When the EK-RA6M3 board is powered on, and LED5 is blinking, it indicates that the S124 Debug MCU is not connected to a programming host. When LED5 is on solid, it indicates that the S124 Debug MCU is connected to a programming interface.

To configure the EK-RA6M3 board to use the Debug on-board mode, configure the jumpers using the following table.

**Table 5. Debug On-Board Mode Jumper Configuration**

Location	Default Open/Closed	Function
J8	Jumper on pins 1-2	Target RA MCU RESET# connected to debug RESET#
J9	Open	S124 Debug MCU in normal operation mode
J29	Jumpers on pins 1-2, 3-4, 5-6, 7-8	Target RA MCU debug signals connected to the Debug Interface

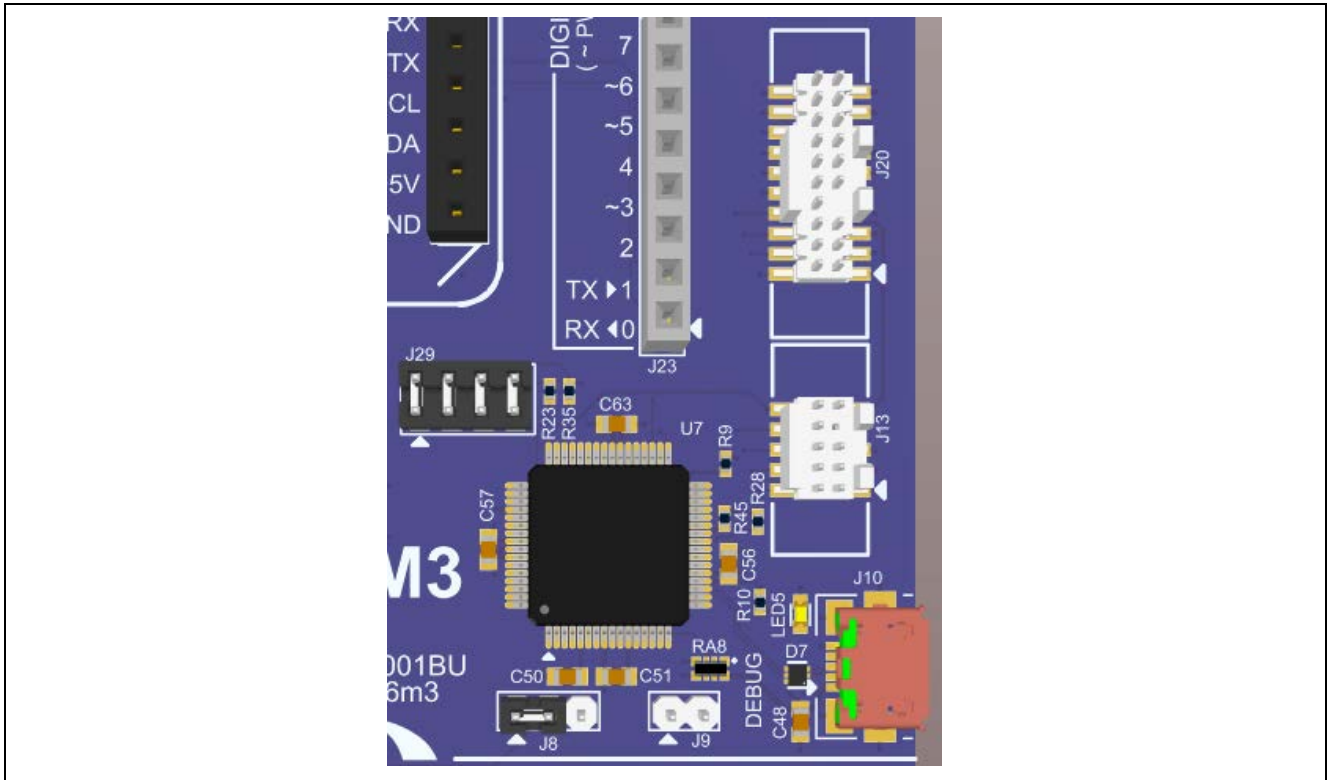

Figure 11. EK-RA6M3 Board Debug Interface

### 5.2.2 Debug In

One 20-pin Cortex® Debug Connector at J20 supports JTAG, SWD, and ETM (TRACE) debug. One 10-pin Cortex® Debug Connector at J13 supports JTAG and SWD. Either of these connectors may be used for external debug of the target RA MCU.

To configure the EK-RA6M3 board to use the Debug in mode, configure the jumpers using the following table.

Table 6. Debug In Mode Jumper Configuration

Location	Default Open/Closed	Function
J8	Jumper on pins 1-2	Target RA MCU RESET# connected to debug RESET#
J9	Jumper on pins 1-2	S124 Debug MCU is held in RESET
J29	Jumpers on pins 1-2, 3-4, 5-6, 7-8	Target RA MCU debug signals connected to the Debug Interface

Table 7. JTAG/SWD/TRACE Connector

JTAG Connector				EK-RA6M3
Pin	JTAG Pin Name	SWD Pin Name	ETM Pin Name	Signal/Bus
J20-1	Vtref	Vtref	Vtref	+3V3
J20-2	TMS	SWDIO	N/A	P108/SWDIO (U1-89)
J20-3	GND	GND	GND	GND
J20-4	TCK	SWCLK	N/A	P300/SWCLK (U1-88)
J20-5	GND	GND	GND	GND
J20-6	TDO	SWO	N/A	P109/TDO (U1-90)
J20-7	Key	Key	Key	N.C.
J20-8	TDI	NC/EXTb	N/A	P110/TDI (U1-91)
J20-9	GNDDetect	GNDDetect	GNDDetect	GND (cut E30 to open)
J20-10	nSRST	nSRST	nSRST	RESET#
J20-11	N/A	N/A	N/A	N.C.

JTAG Connector				EK-RA6M3
Pin	JTAG Pin Name	SWD Pin Name	ETM Pin Name	Signal/Bus
J20-12	N/A	N/A	TCLK	P214/TCLK (U1-62)
J20-13	N/A	N/A	N/A	N.C.
J20-14	N/A	N/A	TDATA0	P211/TDATA0 (U1-63)
J20-15	N/A	N/A	GND	GND
J20-16	N/A	N/A	TDATA1	P210/TDATA1 (U1-64)
J20-17	N/A	N/A	GND	GND
J20-18	N/A	N/A	TDATA2	P209/TDATA2 (U1-65)
J20-19	N/A	N/A	GND	GND
J20-20	N/A	N/A	TDATA3	P208/TDATA3 (U1-66)

Table 8. JTAG/SWD Connector

JTAG Connector				EK-RA6M3
Pin	JTAG Pin Name	SWD Pin Name	ETM Pin Name	Signal/Bus
J13-1	Vtref	Vtref	Vtref	+3V3
J13-2	TMS	SWDIO	N/A	P108/SWDIO (U1-89)
J13-3	GND	GND	GND	GND
J13-4	TCK	SWCLK	N/A	P300/SWCLK (U1-88)
J13-5	GND	GND	GND	GND
J13-6	TDO	SWO	N/A	P109/TDO (U1-90)
J13-7	Key	Key	Key	N.C.
J13-8	TDI	NC/EXTb	N/A	P110/TDI (U1-91)
J13-9	GNDDetect	GNDDetect	GNDDetect	GND (cut E30 to open)
J13-10	nSRST	nSRST	nSRST	RESET#

Note: The Cortex® Debug Connector is fully described in the Arm® CoreSight™ Architecture Specification.

### 5.2.3 Debug Out

The EK-RA6M3 board can be configured to use the S124 Debug MCU to debug target RA MCU on an external board.

A yellow indicator, LED5, shows the visual status of the debug interface. When the EK-RA6M3 board is powered on, and LED5 is blinking, this indicates that the S124 Debug MCU is not connected to a programming host. When LED5 is on solid, this indicates that the S124 Debug MCU is connected to a programming interface.

To configure the EK-RA6M3 board to use the Debug out mode, configure the jumpers according to the following table.

Table 9. Debug Out Mode Jumper Configuration

Location	Default Open/Closed	Function
J8	Jumper on pins 2-3	On-board RA MCU is held in RESET
J9	Open	S124 Debug MCU in normal operation mode
J29	All jumpers removed	Disconnects the on-board RA MCU debug signals from the Debug Interface

### 5.3 Ecosystem

The System Control and Ecosystem area provides users the option to simultaneously connect several 3<sup>rd</sup> party add-on modules compatible with four most popular ecosystems using the following connectors:

1. Two Seeed Grove<sup>®</sup> system (I2C) connectors
2. Two Digilent Pmod<sup>™</sup> (SPI & UART) connectors
3. Arduino<sup>™</sup> (Uno R3) connector
4. MikroElektronika<sup>™</sup> mikroBUS connector

#### 5.3.1 Seeed Grove<sup>®</sup> Connectors

##### 5.3.1.1 Grove 1

A Seeed Grove I2C connector is provided at J27. The RA MCU acts as a two-wire serial master, and a connected module acts as a two-wire serial slave.

**Table 10. Grove 1 Connector**

Grove 1 Connector		EK-RA6M3
Pin	Description	Signal/Bus
J27-1	SCL	P408 (SCL3)
J27-2	SDA	P409 (SDA3)
J27-3	VCC	+3.3 V
J27-4	GND	GND

##### 5.3.1.2 Grove 2

A Seeed Grove I2C connector is provided at J28. The RA MCU acts as a two-wire serial master, and a connected module acts as a two-wire serial slave.

**Table 11. Grove 2 Connector**

Grove 2 Connector		EK-RA6M3
Pin	Description	Signal/Bus
J28-1	SCL	P408 (SCL3)
J28-2	SDA	P409 (SDA3)
J28-3	VCC	+3.3 V
J28-4	GND	GND

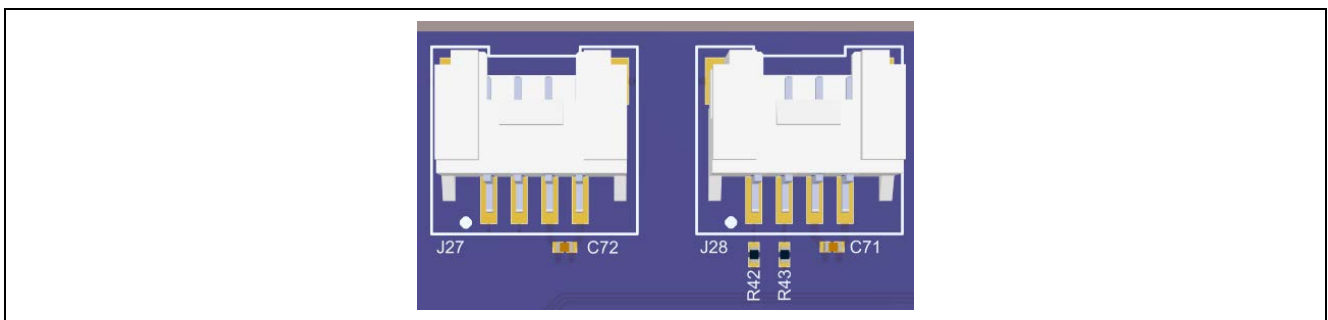

**Figure 12. Seeed Grove Connectors**

#### 5.3.2 Digilent Pmod<sup>™</sup> Connectors

##### 5.3.2.1 PMOD 1

A 12-pin PMOD Type-2A connector is provided at PMOD 1. The RA MCU acts as the SPI master, and the connected module acts as an SPI slave device. This interface may additionally be re-configured in firmware as several other PMOD types.

This PMOD interface supports +3.3 V devices. Please ensure that any PMOD device installed is compatible with a +3.3 V supply.

**Table 12. PMOD 1 Connector**

PMOD 1 Connector		EK-RA6M3
Pin	Description	Signal/Bus
J26-1	SS/CTS_RTS	P205 (SSLB0_A/SS9/CTS_RTS9)
J26-2	MOSI/TXD	P203 (MOSIB_A/MOSI9/TXD9/SDA9)
J26-3	MISO/RXD	P202 (MISOB_A/MISO9/RXD9/SCL9)
J26-4	SCK	P204 (RSPCKB_A/SCK9)
J26-5	GND	GND
J26-6	VCC	+3.3 V
J26-7	INT (slave to master)	P004 (IRQ9)
J26-8	RESET (master to slave)	P800 (GPIO)
J26-9	Not Specified (GPIO)	P801 (GPIO)
J26-10	Not Specified (GPIO)	P802 (GPIO)
J26-11	GND	GND
J26-12	VCC	+3.3 V

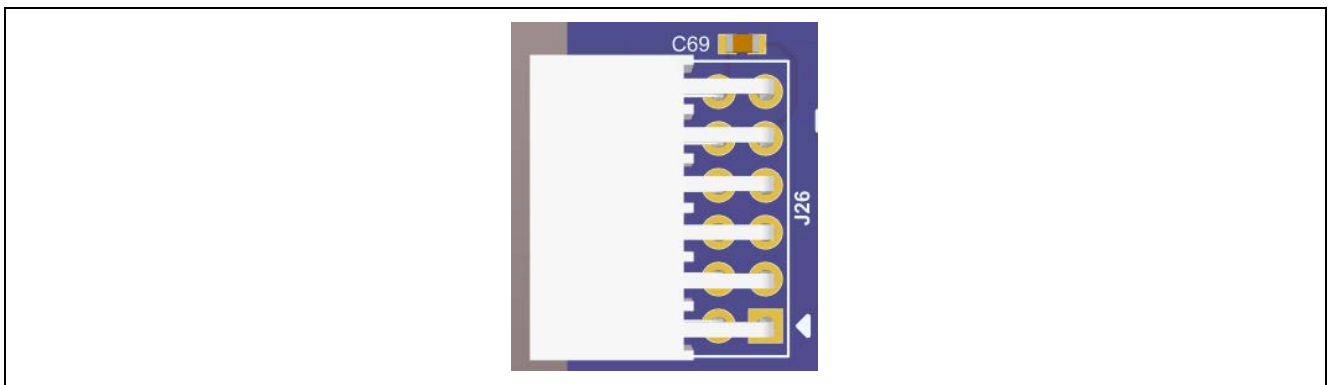
**Figure 13. PMOD 1**

### 5.3.2.2 PMOD 2

A 12-pin PMOD type-2A connector is provided at PMOD 2. The RA MCU acts as the SPI master, and the connected module acts as an SPI slave device. This interface may additionally be re-configured in firmware as several other PMOD types.

This PMOD interface supports +3.3 V devices. Please ensure that any PMOD device installed is compatible with a +3.3 V supply.

**Table 13. PMOD 2 Connector**

PMOD 2 Connector		EK-RA6M3
Pin	Description	Signal/Bus
J25-1	SS/CTS_RTS	P107 (SS8/CTS8)
J25-2	MOSI/TXD	P105 (MOSI8/TXD8/SDA8)
J25-3	MISO/RXD	P104 (MISO8/RXD8/SCL8)
J25-4	SCK	P106 (SCK8)
J25-5	GND	GND
J25-6	VCC	+3.3 V
J25-7	INT (slave to master)	P708 (IRQ11)
J25-8	RESET (master to slave)	P803 (GPIO)
J25-9	Not Specified (GPIO)	P804 (GPIO)
J25-10	Not Specified (GPIO)	P805 (GPIO)
J25-11	GND	GND
J25-12	VCC	+3.3 V

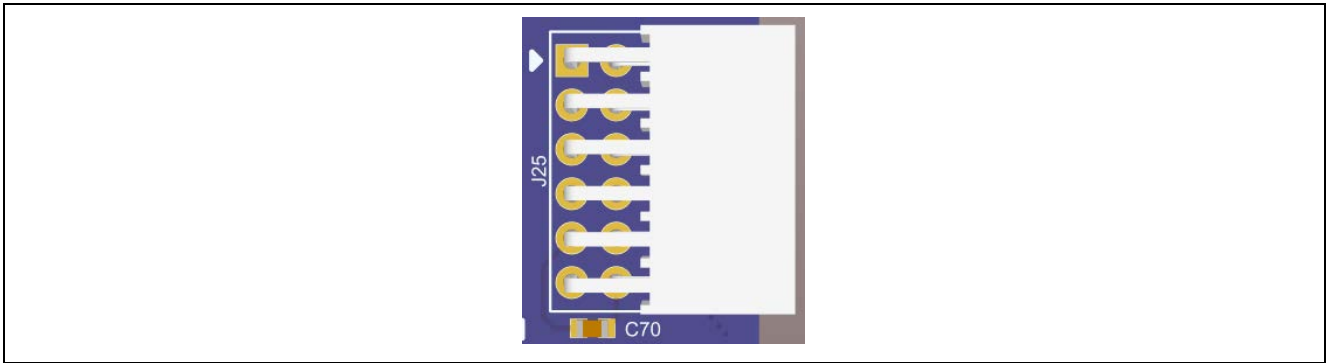

Figure 14. PMOD 2

### 5.3.3 Arduino™ Connector

Near the center of the System Control and Ecosystem Access area is an Arduino Uno R3 compatible connector interface.

Table 14. Arduino Uno Connections

Arduino Compatible Connector			EK-RA6M3
Pin	Description	Signal Group	Signal/Bus
J18-1	NC	N/A	NC
J18-2	IOREF	Power	+3.3 V
J18-3	RESET#	Power	P413 (Arduino RESET#)
J18-4	+3.3 V	Power	+3.3 V
J18-5	+5 V	Power	+5 V
J18-6	GND	Power	GND
J18-7	GND	Power	GND
J18-8	NC (VIN)	Power	NC
J19-1	AN0	Analog	P000 (AN000)
J19-2	AN1	Analog	P001 (AN001)
J19-3	AN2	Analog	P002 (AN002)
J19-4	AN3	Analog	P507 (AN119)
J19-5	AN4	Analog	P508 (AN020)
J19-6	AN5	Analog	P014 (AN005)
J23-1	RXD	Digital	P614 (RXD7)
J23-2	TXD	Digital	P613 (TXD7)
J23-3	INT0	Digital	P506 (IRQ15 / AN019)
J23-4	INT1	Digital	P505 (IRQ14 / PWM(GTIOC13B) / AN118)
J23-5	T0	Digital	P908 (GPIO / PWM(GTIOC12A))
J23-6	T1	Digital	P907 (GPIO / PWM(GTIOC12B))
J23-7	AIN0	Digital	P504 (GPIO / AN018 / PWM(GTIOC13A))
J23-8	AIN1	Digital	P503 (GPIO / AN117)
J24-1	CLK0	Digital	P611 (GPIO / CLKOUT)
J24-2	GPIO	Digital	P415 (GPIO / PWM(GTIOC0A))
J24-3	SPI SS	Digital	P414 (SSLA1 / PWM(GTIOC0B))
J24-4	SPI MOSI	Digital	P411 (MOSIA / PWM(GTIOC9A))
J24-5	SPI MISO	Digital	P410 (MISOA)
J24-6	SPI SCK	Digital	P412 (RSPCKA)
J24-7	GND	N/A	GND
J24-8	AREF	N/A	+3.3 V
J24-9	I2C SDA	N/A	P511 (SDA2)

Arduino Compatible Connector			EK-RA6M3
Pin	Description	Signal Group	Signal/Bus
J24-10	I2C SCL	N/A	P512 (SCL2)

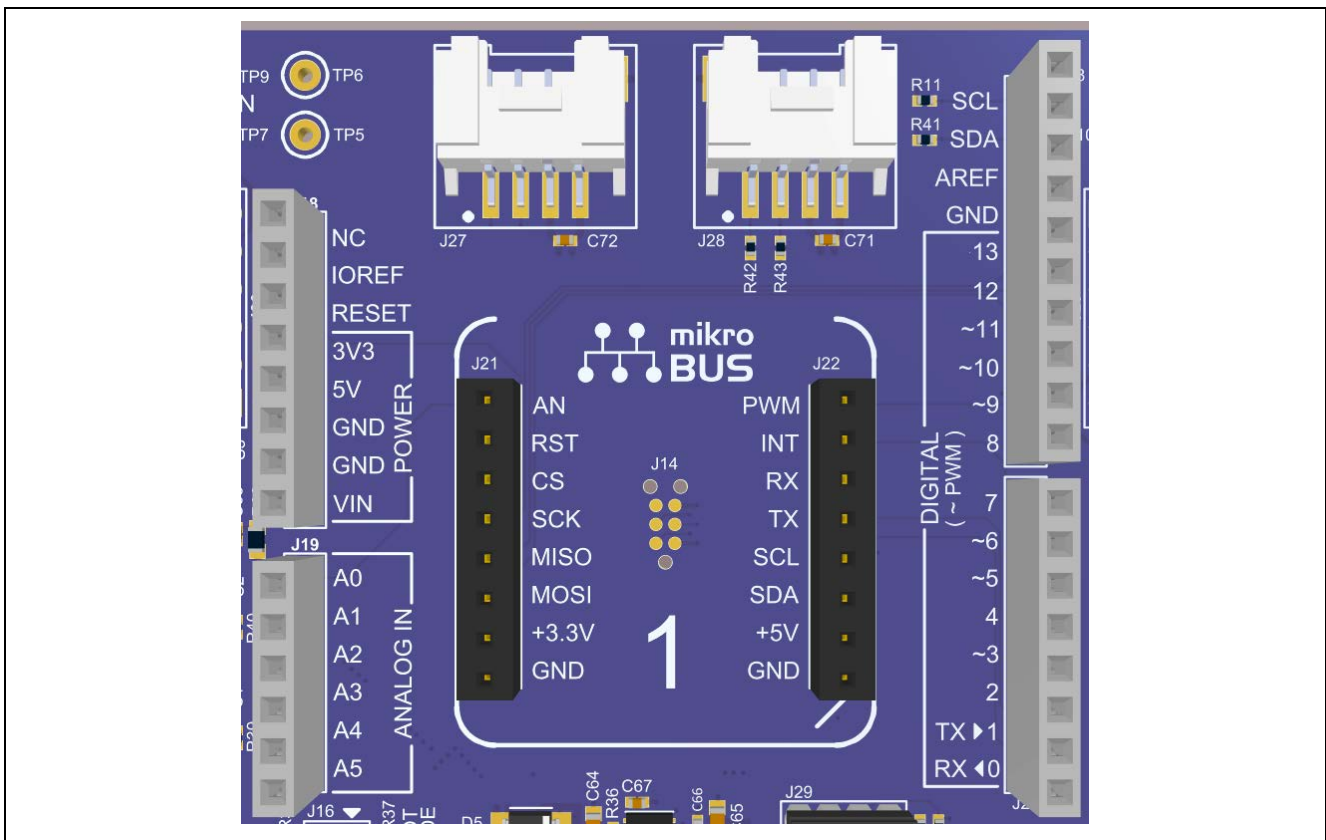

Figure 15. Arduino Uno Connectors

### 5.3.4 MikroElektronika™ mikroBUS Connector

In the center of the System Control and Ecosystem Access area is a mikroBus compatible connector interface. This interface is compliant with mikroBus Standard Specifications revision 2.00.

Table 15. mikroBus Connections

mikroBus Connector		EK-RA6M3
Pin	Description	Signal/Bus
J21-1	AN (Analog)	P000 (AN000)
J21-2	RST (Reset)	P413 (mikroBus RESET#)
J21-3	CS (SPI Chip Select)	P414 (SSLA1)
J21-4	SCK (SPI Clock)	P412 (RSPCKA)
J21-5	SPI MISO	P410 (MISOA)
J21-6	SPI MOSI	P411 (MOSIA)
J21-7	+3.3 V	+3.3 V
J21-8	GND	GND
J22-1	PWM	P415 (GTIOC0A)
J22-2	INT (Hardware Interrupt)	P505 (IRQ14)
J22-3	UART RX	P614 (RXD7)
J22-4	UART TX	P613 (TXD7)
J22-5	SCL (I2C Clock)	P512 (SCL2)
J22-6	SDA (I2C Data)	P511 (SDA2)
J22-7	+5 V	+5 V
J22-8	GND	GND

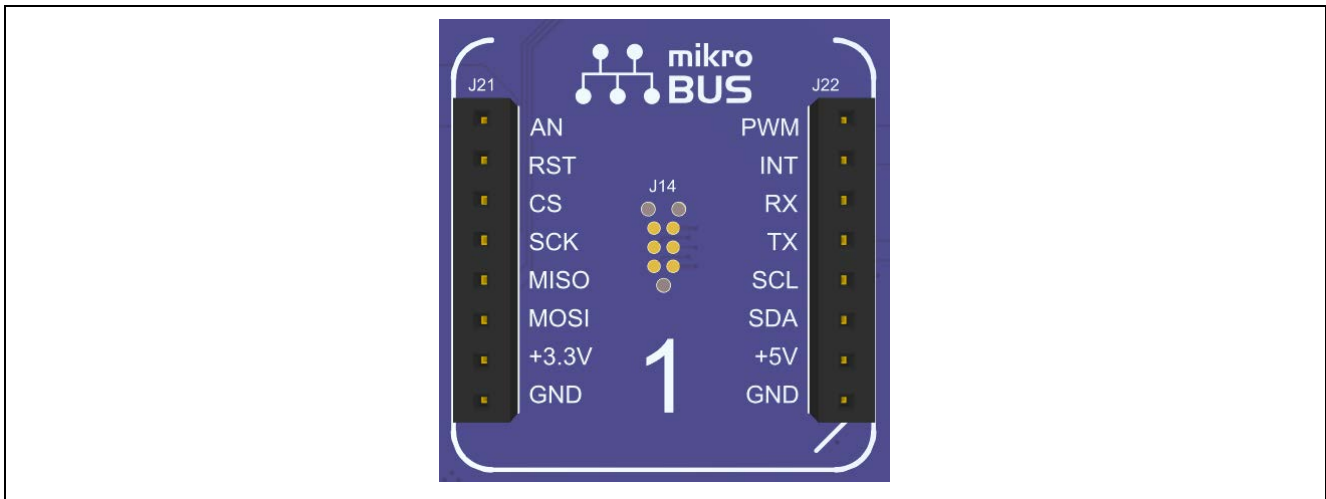

Figure 16. mikroBus Connection

## 5.4 Connectivity

### 5.4.1 USB Full Speed

The USB Micro-AB connection jack (J11) connects the RA MCU USB Full Speed interface to an external USB interface, allowing communications for testing and use of the RA MCU firmware. This connection can be configured as either a USB Device or a USB Host interface.

For a USB Device configuration, set jumper J12 to pins 2-3, install a jumper on J15 pins 1-2, and configure the RA MCU firmware to use the USB Full Speed ports in device mode. Power from an external USB Host on this connection can be used to provide power to the EK-RA6M3 board.

For a USB Host configuration, set jumper J12 to pins 1-2, remove the jumper from J15, and configure the RA MCU firmware to use the USB Full Speed ports in host mode. In this configuration, power to J11 is supplied from U6. The total current available from U6 is 500 mA. Note that the input power sources must be configured with enough power for the EK-RA6M3 board and the USB device connected to the host port. Connect the included USB type-A female to micro-B male cable to J11. USB device cables or devices can be connected to the USB Full Speed port using this cable.

Table 16. USB Full Speed Connector

USB Full Speed Connector		EK-RA6M3
Pin	Description	Signal/Bus
J11-1	+5VDC	+5VUSB (Host Mode) P407/USBFS_VBUS = 2/3 of +5VUSB at J11
J11-2	Data-	USB_DM
J11-3	Data+	USB_DP
J11-4	USB ID, jack internal switch, cable inserted	N.C.
J11-5	Ground	GND

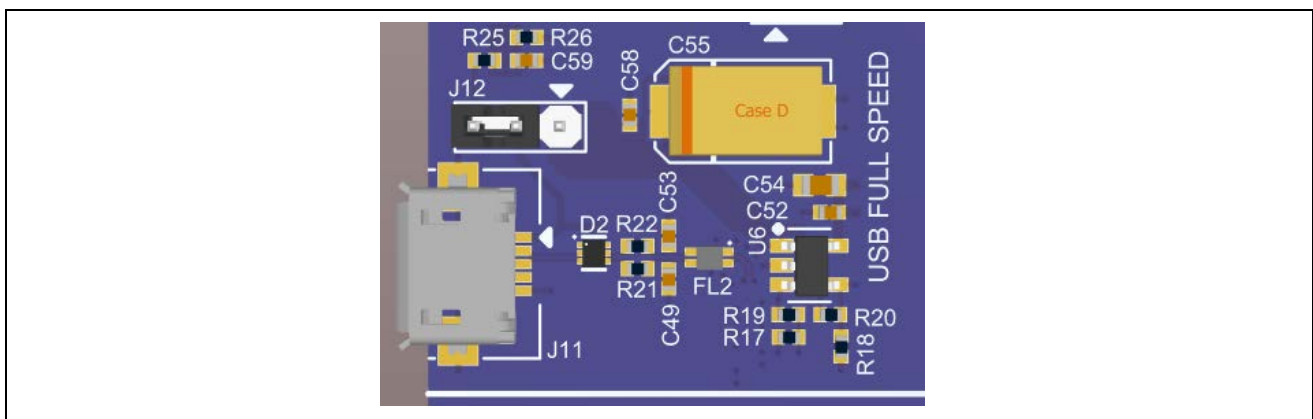

Figure 17. USB Full Speed Connector

## 5.5 Miscellaneous

### 5.5.1 User and Power LEDs

5 LEDs are provided on the EK-RA6M3 board. In addition, the Ethernet connector has built-in link status and link speed LEDs.

Behavior of the LEDs on the EK-RA6M3 board is described in the following table.

**Table 17. EK-RA6M3 Board LED Functions**

Designator	Color	Function	MCU Control Port
LED1	Blue	User LED 1	P403
LED2	Green	User LED 2	P400
LED3	Red	User LED 3	P100
LED4	White	Power LED	+3.3 V
LED5	Orange	Debug LED	J-Link OB MCU

The User LEDs may be isolated from the RA MCU, so the associated ports can be used for other purposes. To separate LED1 from P403, Trace Cut Jumper E27 must be open. To separate LED2 from P400, Trace Cut Jumper E26 must be open. To separate LED3 from P100, Trace Cut Jumper E28 must be open.

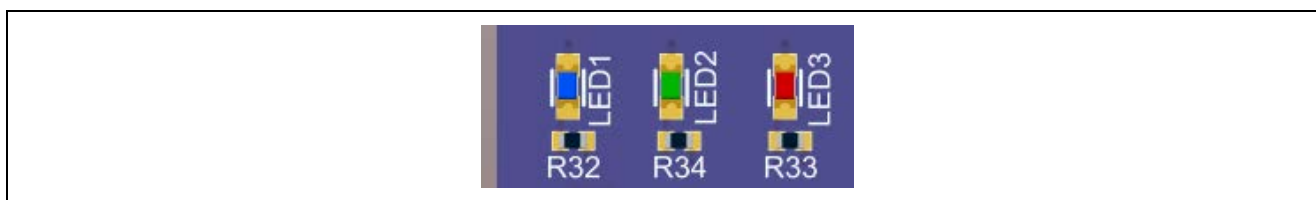

**Figure 18. User LEDs**



**Figure 19. Power LED**

### 5.5.2 User and Reset Switches

Three miniature, momentary, mechanical push-button type SMT switches are mounted on the EK-RA6M3 board.

Pressing the Reset switch (S3) generates a reset signal to restart the RA MCU.

**Table 18. EK-RA6M3 Board Switches**

Designator	Function	MCU Control Port	Button Color
S3	MCU Reset Switch	RESET#	Red
S1	User Switch	P009 (IRQ13-DS)	Blue
S2	User Switch	P008 (IRQ12-DS)	Blue

The User Switches S1 and S2 may be isolated from the RA MCU, so the associated ports can be used for other purposes. To separate S1 from P009, Trace Cut Jumper E31 must be open. To separate S2 from P008, Trace Cut Jumper E32 must be open.

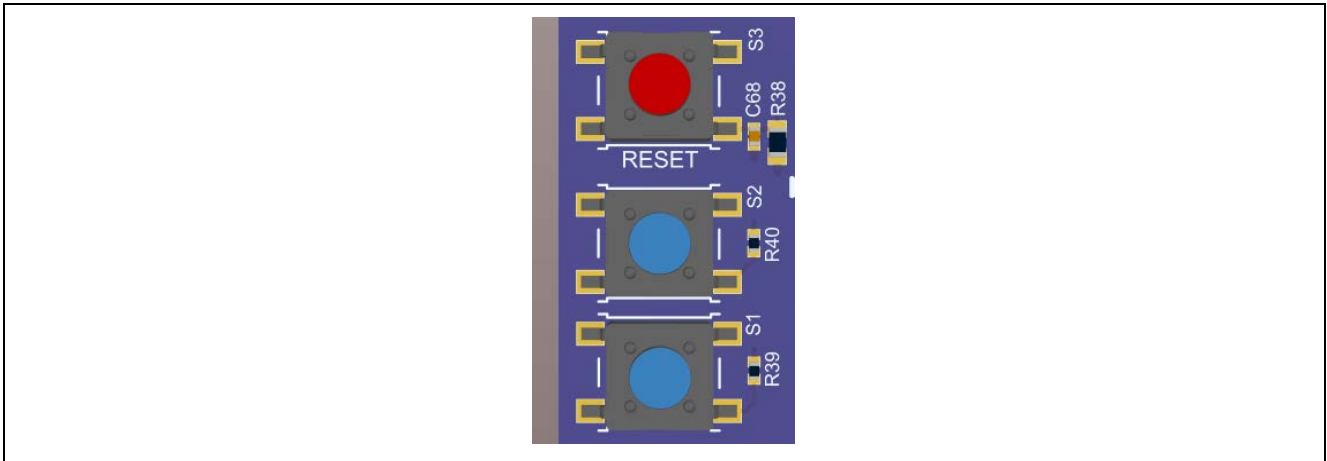

Figure 20. Reset and User Switches

### 5.5.3 MCU Boot Mode

A two-pin header (J16) is provided to select the Boot mode of the RA MCU. For normal operation, or Single-Chip mode, leave J16 open. To enter SCI Boot mode or USB Boot mode, place a jumper on J16, then press the MCU Reset switch (S3) or remove power from the board and re-apply power.

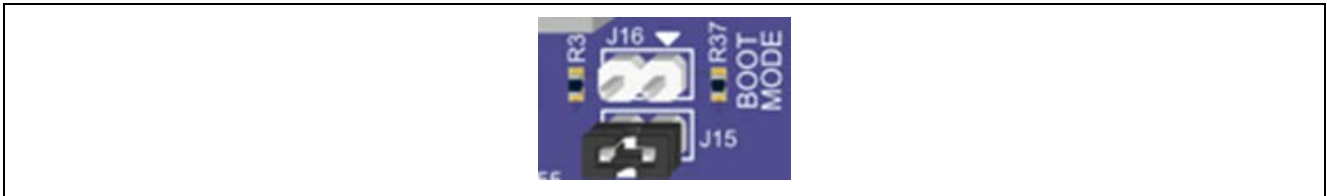

Figure 21. Boot Mode

## 6. EK-RA6M3 Board Special Feature Access Area

The Special Feature Access area provides features specific to the RA6M3 MCU group such as Ethernet MAC controller, USB High Speed (Host and Device) and QSPI.

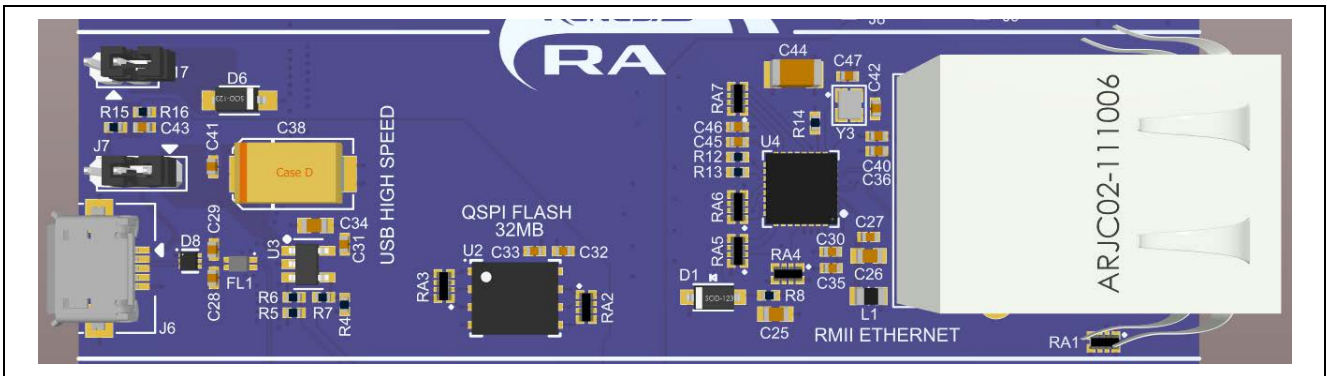

Figure 22. Special Features Access Area

### 6.1 Ethernet

The Ethernet interface uses an RMII Ethernet Physical Layer Transceiver (PHY) (U4), connected to an RJ45 standard Ethernet connector (J5) with integrated magnetics and status indicators. The Ethernet clock is sourced from a precision 25 MHz clock crystal connected directly to the Ethernet PHY.

The RMII signals used for the Ethernet port are connected from the RA MCU through a set of Trace Cut Jumpers. To isolate the Ethernet PHY from the RA MCU, each of the RMII signal Trace Cut Jumpers must be OPEN.

**Table 19. Ethernet Port Assignments**

Ethernet Signal Description	RA6M3 MCU Port	RMII Trace Cut Jumper
IRQ	P706 (IRQ7)	E18
RESET#	P404	E14
MDC	P401	E24
MDIO	P402	E25
CRS_DV	P705	E20
TXD_EN	P405	E17
TXD0	P700	E16
TXD1	P406	E15
RXD1	P703	E23
RXD0	P702	E22
RX_ER	P704	E19
REF50CK	P701	E21

**Table 20. Ethernet Components**

Component	Manufacturer	Manufacturer Part Number
Ethernet PHY	Microchip	KSZ8091RNB
RJ-45 Connector	Abracon	ARJC02-111009D
25 MHz Oscillator	TXC	8Y-25.000MEEQ-T

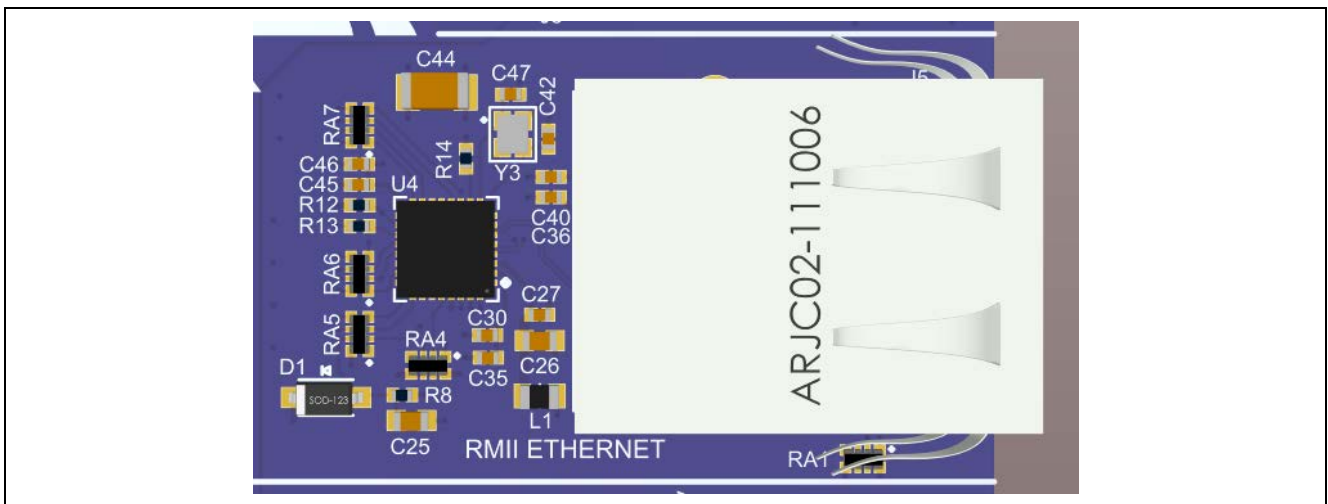

**Figure 23. Ethernet Connector**

## 6.2 USB High Speed

The USB Micro-AB connection jack (J6) connects the RA MCU USB High Speed interface to an external USB interface, allowing communications for testing and use of the RA MCU firmware. This connection can be configured as either a USB Device or a USB Host interface.

For a USB Device configuration, set Jumper J7 to pins 2-3, install a jumper on J17 pins 1-2, and configure the RA MCU firmware to use the USB High Speed ports in device mode. Power from an external USB Host on this connection can be used to provide power to the EK-RA6M3 board.

For a USB Host configuration, set Jumper J7 to pins 1-2, remove the jumper from J17, and configure the RA MCU firmware to use the USB High Speed ports in host mode. In this configuration, power to J6 is supplied from U3. The total current available from U3 is 500 mA. Note that the input power sources must be configured with enough power for the EK-RA6M3 board and the USB device connected to the host port. Connect the included USB type-A female to micro-B male cable to J6. USB device cables or devices can be connected to the USB High Speed port using this cable.

**Table 21. USB High Speed Connector**

USB High Speed Connector		EK-RA6M3
Pin	Description	Signal/Bus
J6-1	+5 VDC	+5 VUSB (Host Mode) PB01/USBHS_VBUS = 2/3 of +5VUSB at J6
J6-2	Data-	USBHS_DM
J6-3	Data+	USBHS_DP
J6-4	USB ID, jack internal switch, cable inserted	N.C.
J6-5	Ground	GND

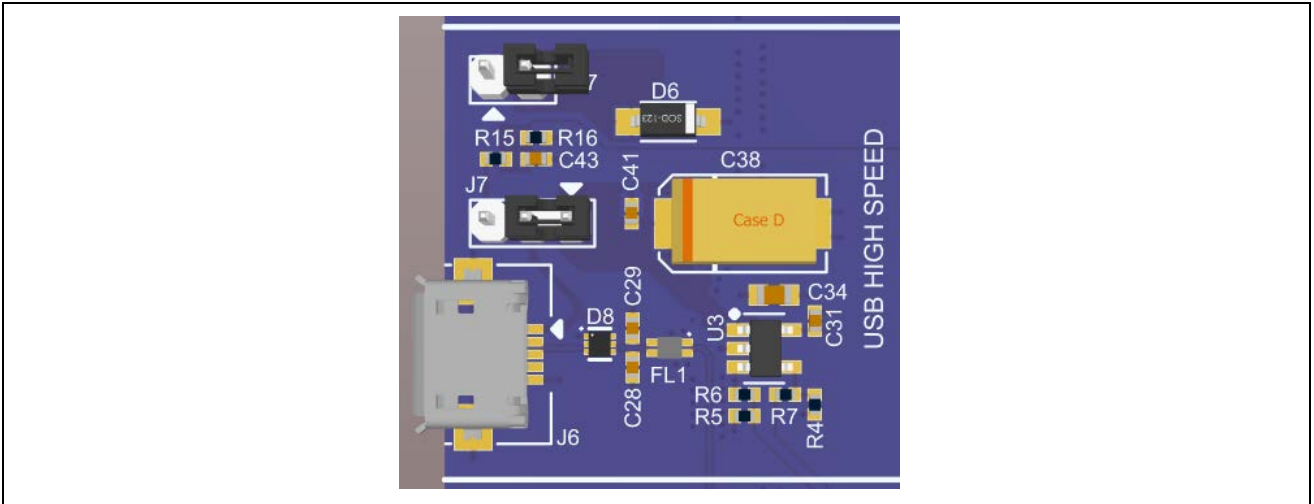

**Figure 24. USB High Speed Connector**

### 6.3 QSPI Flash

Included on the EK-RA6M3 board is a Macronix 256 Mb (32 MB) serial flash QSPI memory (MX25L25645G). The QSPI serial flash device (U2) connects to the QSPI peripheral on the RA MCU and defaults to standard SPI mode initially. The flash memory is enabled for XIP (Execute-in-place) mode directly after power-on.

**Table 22. QSPI Flash Port Assignments**

QSPI Signal Description	EK-RA6M3 Port
QSPI CS#	P306
QSPI CLK	P305
QSPI DQ0	P307
QSPI DQ1	P308
QSPI DQ2	P309
QSPI DQ3	P310

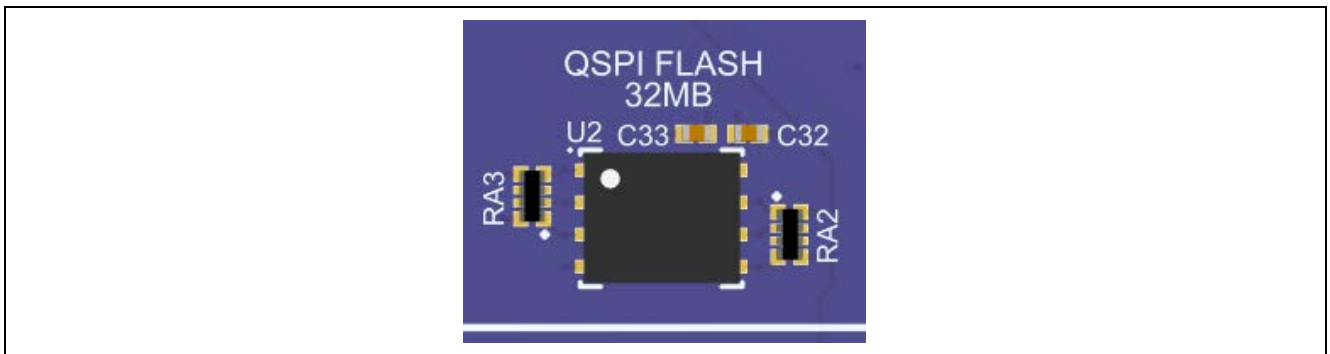

**Figure 25. QSPI Flash**

## 7. EK-RA6M3 Board MCU Native Pin Access Area

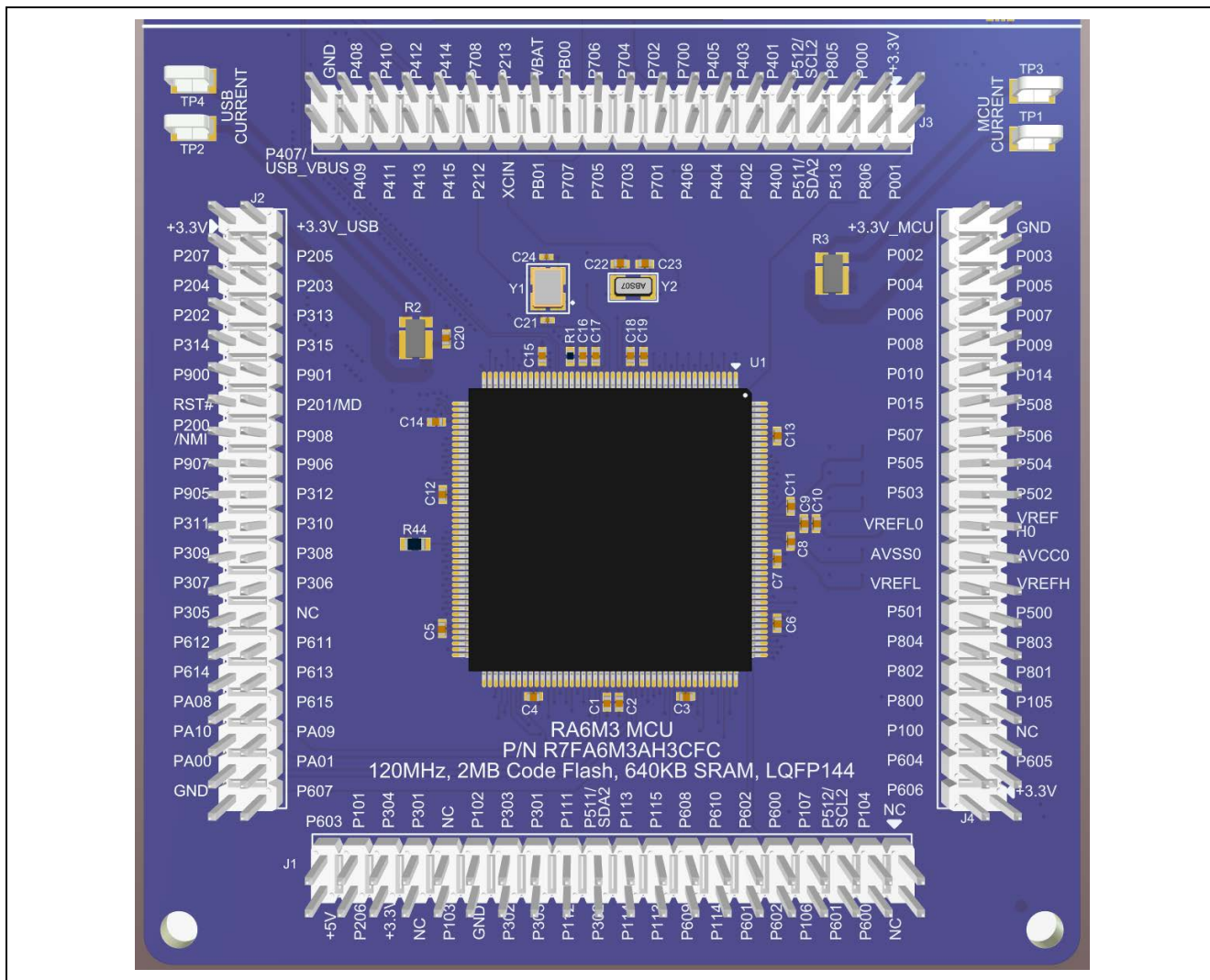

Figure 26. Native Pin Access Area

### 7.1 Breakout Pin Headers

The EK-RA6M3 board pin headers, J1, J2, J3 and J4, provide access to all RA MCU interface signals, and to voltages for all RA MCU power terminals. Each header pin is labeled with the voltage or port connected to that pin. Refer to the RA6M3 MCU Group User's Manual for details of each port function, and the EK-RA6M3 board schematic for pin header port assignments.

The placement of the breakout pin headers allows for a standard 2.54 mm (0.100") center breadboard to be placed on all four pin headers simultaneously. This can be used for prototyping and testing of custom circuitry for use with the RA6M3 MCU.

Pin header J1 is configured to support the Graphics Expansion Module. See Section 8 for more details on the Graphics Expansion Board.

### 7.2 MCU and USB Current Measurement

Included in the Native Pin Access area are current measurement resistors and test points to measure the MCU USB controller current and the MCU core power current.

The EK-RA6M3 board provides precision 5 mΩ resistors (Yageo, part number PS0612FKE070R005L) for current measurement of the main 3.3 V MCU power, and the 3.3 V USB MCU power. Measure the voltage drop across these resistors and use Ohm's Law to calculate the current. For convenience, TP1 and TP3 are provided to measure the main 3.3 V MCU power, and TP2 and TP4 are provided to measure the 3.3 V USB MCU power. See Figure 29 for the location of TP1, TP3, TP2 and TP4.

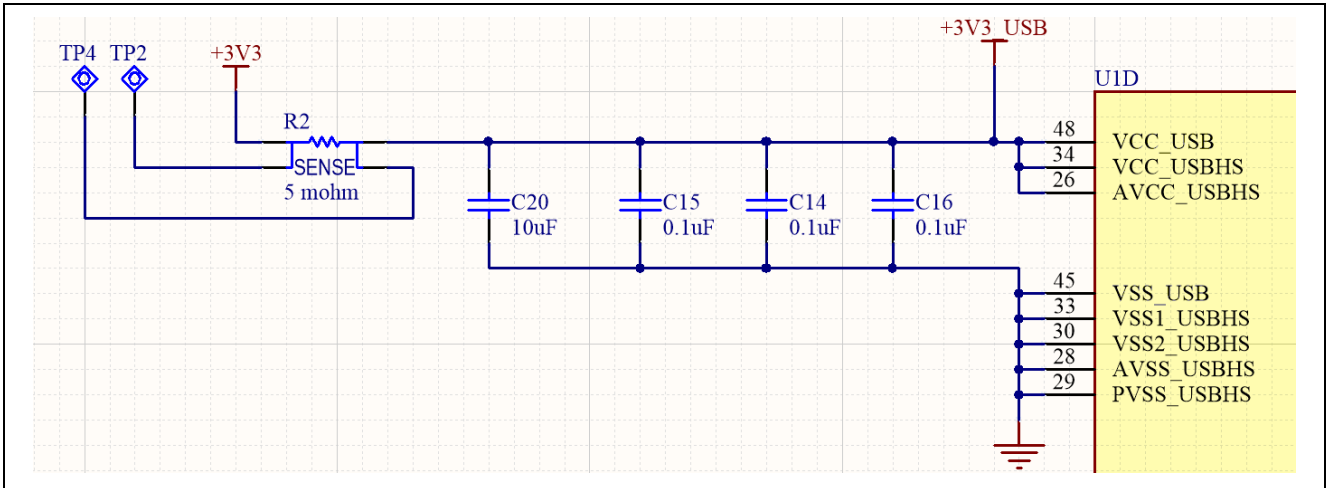

Figure 27. RA MCU USB Current Measurement Circuit

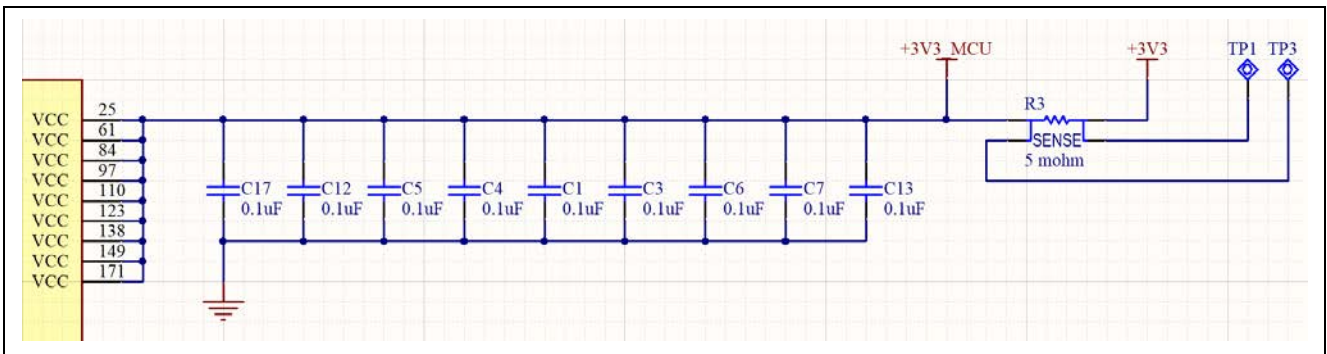

Figure 28. RA MCU +3.3 V Current Measurement Circuit

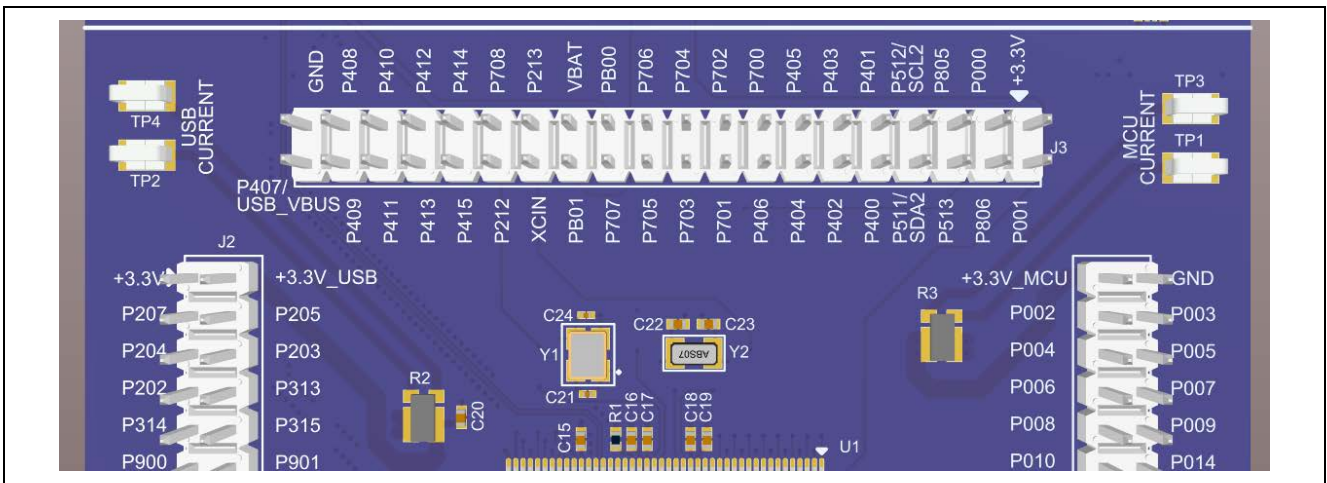

Figure 29. RA MCU Current Measurement

## 8. Graphics Expansion Board

The Graphics Expansion Board includes a 4.3-inch 480 x 272 pixel TFT color LCD with a capacitive touch overlay. The LED backlight in the TFT display is driven by a backlight controller circuit on the Graphics Expansion Board. The port driving the backlight controller is capable of PWM output, so the intensity of the LED backlight can be adjusted by the RA MCU.

### 8.1 Connecting the Graphics Expansion Board on to EK-RA6M3 Board

The Graphics Expansion Board can be connected to the EK-RA6M3 board using the connector CN1 on the Graphics Expansion Board and pin header J1 on the EK-RA6M3 board.

Alignment arrows are printed on each board to assist with correct alignment and connection. Use the alignment arrows to ensure that all of the pins between CN1 and J1 are connected correctly.

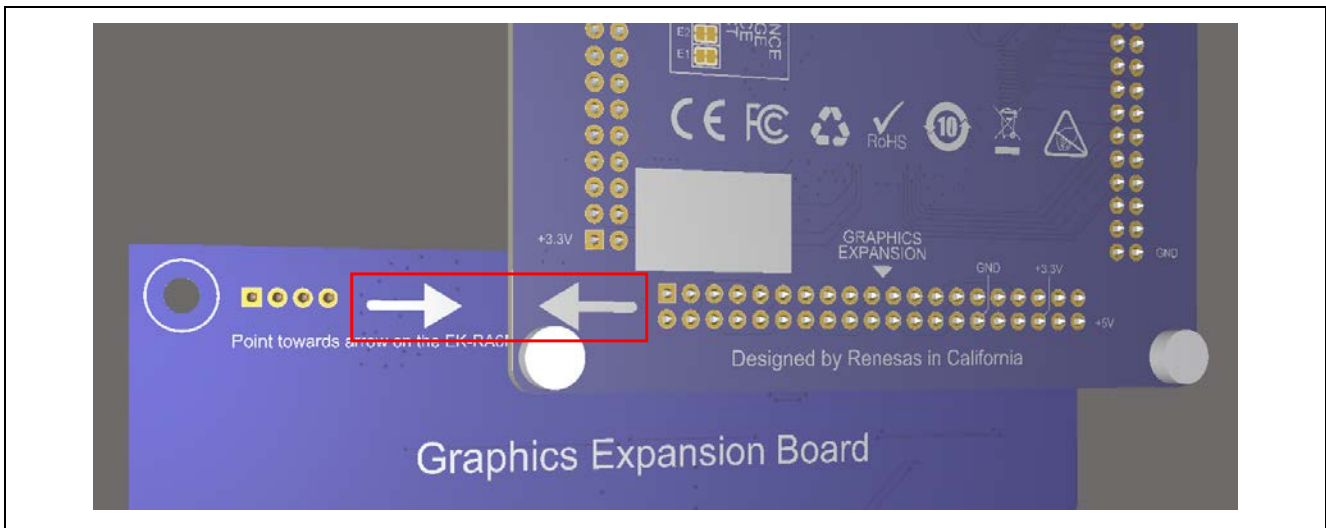

**Figure 30. Aligning Graphics Expansion Board and the EK-RA6M3 Board Using the Alignment Arrows Printed on the Bottom of Each Board**

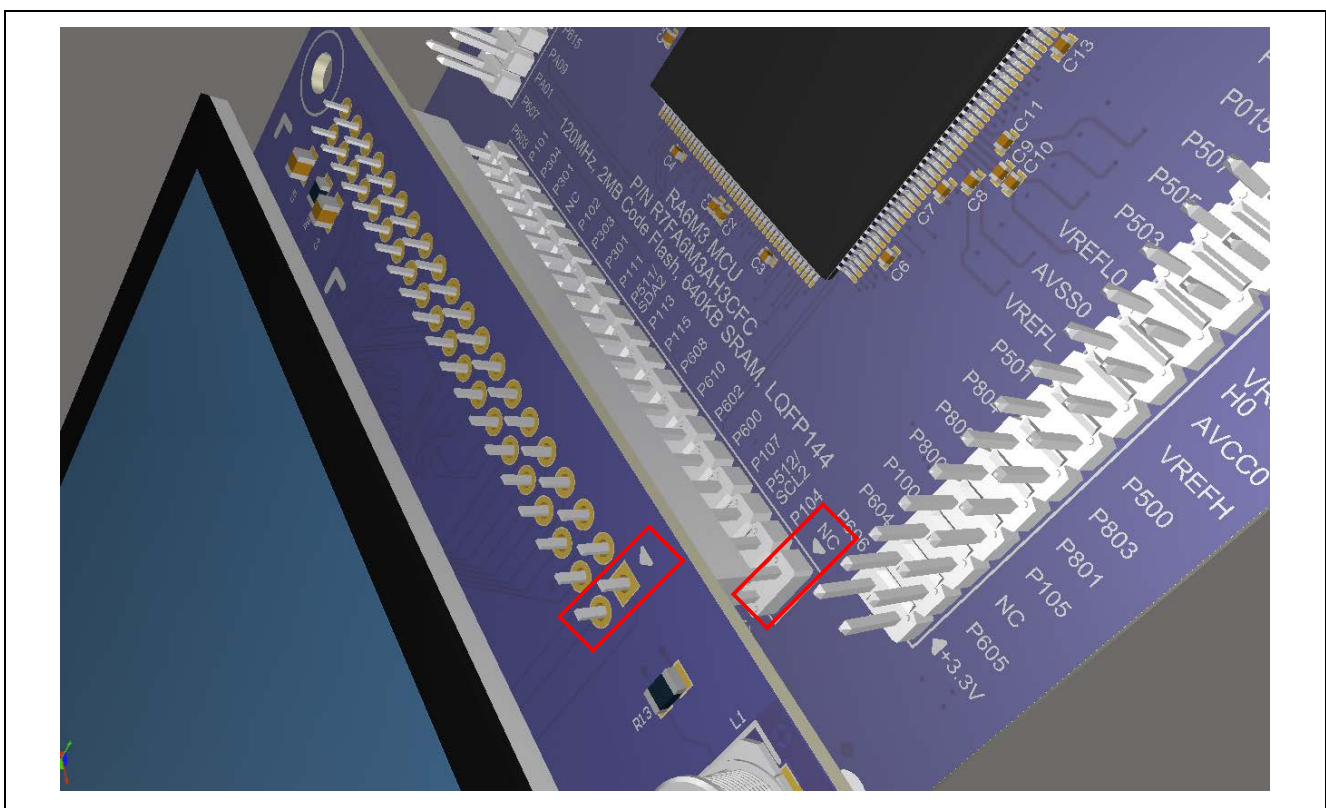

**Figure 31. Aligning Graphics Expansion Board and the EK-RA6M3 Board Using the Alignment Triangles Printed on the Top of Each Board**

### 8.2 Signal Assignment

The RA MCU GLCD ports are configured for a 5-6-5 color depth. Table 23 shows the GLCD port assignments and signal names between the EK-RA6M3 board and the Graphics Expansion Board.

Note that P206, which is used as the interrupt for the capacitive touch portion of the LCD, must have the internal pull-up feature enabled in the RA6M3 MCU configuration. This will ensure proper responsiveness of the LCD capacitive touch overlay.

Some ports used for the Graphics Expansion Board are also used by PMOD 2. To ensure correct operation, do not use the Graphics Expansion Board and PMOD 2 at the same time. Other ecosystem connections, including PMOD 1, are available to use while the Graphics Expansion Board is in use.

**Table 23. Graphics Expansion Connector Signals**

EK-RA6M3 Board			Graphics Expansion Board		
J1 Pin Number	RA MCU Port	RA MCU GLCD Signal	RGB Signal	Graphics Module Signal	CN1 Pin Number
J1-1	N.C.	N.C.	N.C.	DITH	CN1-1
J1-2	N.C.	N.C.	N.C.	MODE	CN1-2
J1-3	P104	TCON2	DE	RGB_EN	CN1-3
J1-4	P600	DATA2	B0	B0	CN1-4
J1-5	P512	SCL2	SCL	SCL	CN1-5
J1-6	P601	DATA3	B1	B1	CN1-6
J1-7	P107	DATA1	B4	B4	CN1-7
J1-8	P106	DATA0	B3	B3	CN1-8
J1-9	P600	DATA2	B5	B5	CN1-9
J1-10	P602	DATA4	B2	B2	CN1-10
J1-11	P602	DATA4	B7	B7	CN1-11
J1-12	P601	DATA3	B6	B6	CN1-12
J1-13	P610	DATA5	G2	G2	CN1-13
J1-14	P114	DATA9	G0	G0	CN1-14
J1-15	P608	DATA7	G4	G4	CN1-15
J1-16	P609	DATA6	G3	G3	CN1-16
J1-17	P115	DATA8	G5	G5	CN1-17
J1-18	P113	DATA10	G1	G1	CN1-18
J1-19	P113	DATA10	G7	G7	CN1-19
J1-20	P114	DATA9	G6	G6	CN1-20
J1-21	P511	SDA	SDA	SDA	CN1-21
J1-22	P302	DATA14	R1	R1	CN1-22
J1-23	P111	DATA12	R4	R4	CN1-23
J1-24	P112	DATA11	R3	R3	CN1-24
J1-25	P301	DATA13	R5	R5	CN1-25
J1-26	P303	DATA15	R2	R2	CN1-26
J1-27	P303	DATA15	R7	R7	CN1-27
J1-28	P302	DATA14	R6	R6	CN1-28
J1-29	P102	TCON0	HSYNC	HSYNC	CN1-29
J1-30	GND	GND	GND	GND	CN1-30
J1-31	N.C.	N.C.	N.C.	LR_INV	CN1-31
J1-32	P103	TCON1	VSYNC	VSYNC	CN1-32
J1-33	P301	DATA13	R0	R0	CN1-33
J1-34	N.C.	N.C.	N.C.	UD_INV	CN1-34
J1-35	P304	RST	RST	RESET#	CN1-35
J1-36	+3.3 V	+3.3 V	+3.3 V	+3.3 V	CN1-36
J1-37	P101	CLK	CLK	CLK	CN1-37
J1-38	P206	IRQ0	IRQ	INTP	CN1-38
J1-39	P603	GTIOC7A	BLEN	BLEN	CN1-39
J1-40	+5 V	+5 V	+5 V	+5 V	CN1-40

## 9. Certifications

The EK-RA6M3G v1 kit meets the following certifications/standards. See page 3 of this user's manual for the disclaimer and precautions.

### 9.1 EMC/EMI Standards

- FCC Notice (Class A)



This device complies with part 15 of the FCC Rules. Operation is subject to the following two conditions: (1) This device may not cause harmful interference, and (2) this device must accept any interference received, including interference that may cause undesired operation.

NOTE- This equipment has been tested and found to comply with the limits for a Class A digital device, pursuant to Part 15 of the FCC Rules. These limits are designed to provide reasonable protection against harmful interference in a residential installation. This equipment generates, uses and can radiate radio frequency energy and, if not installed and used in accordance with the instructions, may cause harmful interference to radio communications. However, there is no guarantee that interference will not occur in a particular installation. If this equipment does cause harmful interference to radio or television reception, which can be determined by turning the equipment off and on, the user is encouraged to try to correct the interference by one or more of the following measures:

- Reorient or relocate the receiving antenna.
- Increase the separation between the equipment and receiver.
- Connect the equipment into an outlet on a circuit different from that to which the receiver is connected.
- Consult the dealer or an experienced radio/television technician for help.

- Innovation, Science and Economic Development Canada ICES-003 Compliance:

CAN ICES-3 (A)/NMB-3(A)

- CE Class A (EMC)



This product is herewith confirmed to comply with the requirements set out in the Council Directives on the Approximation of the laws of the Member States relating to Electromagnetic Compatibility Directive 2014/30/EU.

**Warning** – This is a Class A product. In a domestic environment this product may cause radio interference in which case the user may be required to take adequate measures to correct this interference.

- UKCA Class A (EMC)



This product is in conformity with the following relevant UK Statutory Instrument(s) (and its amendments): 2016 No. 1091 Electromagnetic Compatibility Regulations 2016.

**Warning** – This is a Class A product. In a domestic environment this product may cause radio interference in which case the user may be required to take adequate measures to correct this interference.

- Taiwan: CNS 15936, Class A limits 警告：為避免電磁干擾，本產品不應安裝或使用於住宅環境
- Australia/New Zealand AS/NZS CISPR 32:2015, Class A

### 9.2 Material Selection, Waste, Recycling and Disposal Standards

- EU RoHS
- WEEE Directive (2012/19/EU) & The Waste Electrical and Electronic Equipment Regulations 2013



- The WEEE (Waste Electrical and Electronic Equipment) regulations put responsibilities on producers for the collection and recycling or disposal of electrical and electronic waste. Return of WEEE under these regulations is applicable in the UK and European Union.

- This equipment (including all accessories) is not intended for household use. After use the equipment cannot be disposed of as household waste, and the WEEE must be treated, recycled and disposed of in an environmentally sound manner.

- Renesas Electronics Europe GmbH can take back end of life equipment. Register for this service at;
- <https://www.renesas.com/en/form/weee-questionnaire>
- China SJ/T 113642014, 10-year environmental protection use period.

### 9.3 Safety Standards

- UL 94V-0

## 10. Design and Manufacturing Information

The design and manufacturing information for the EK-RA6M3G v1 kit is available on the Renesas website. The EK-RA6M3G v1 kit consists of two components. (1) The EK-RA6M3 and (2) the Graphics Expansion Board.

Download the EK-RA6M3 design package from the Renesas website. This is available from [renesas.com/ek-ra6m3](https://www.renesas.com/ek-ra6m3) under Documentation | PCB Design Files as EK-RA6M3 v1 - Design Package.

Download the Graphics Expansion Board design package from the Renesas website. This is available from [renesas.com/ek-ra6m3g](https://www.renesas.com/ek-ra6m3g) under Documentation | PCB Design Files as Graphic Expansion Board v1 for EK-RA6M3 - Design Package.

**Table 24. EK-RA6M3 Board Design Package Contents**

File Type	Content	File/Folder Name
File (PDF)	Schematics	ek-ra6m3-v1-schematics
File (PDF)	Mechanical Drawing	ek-ra6m3-v1-mechdwg
File (PDF)	3D Drawing	ek-ra6m3-v1-3d
File (PDF)	BOM	ek-ra6m3-v1-bom
Folder	Manufacturing Files	Manufacturing Files
Folder	Design Files	Design Files-Altium

**Table 25. Graphics Expansion Board Design Package Contents**

File Type	Content	File/Folder Name
File (PDF)	Schematics	ek-ra6m3-v1-schematics
File (PDF)	Schematics	app_lcd-ek-ra6m3g-v1-schematics
File (PDF)	Mechanical Drawing	app_lcd-ek-ra6m3g-v1-mechdwg
File (PDF)	3D Drawing	app_lcd-ek-ra6m3g-v1-3d
File (PDF)	BOM	app_lcd-ek-ra6m3g-v1-bom
Folder	Manufacturing Files	Manufacturing Files
Folder	Design Files	Design Files-Altium

## 11. Website and Support

Visit the following URLs to learn about the kit and the RA family of microcontrollers, download tools and documentation, and get support.

EK-RA6M3 Resources	<a href="https://www.renesas.com/ek-ra6m3">renesas.com/ek-ra6m3</a>
EK-RA6M3G Resources	<a href="https://www.renesas.com/ek-ra6m3g">renesas.com/ek-ra6m3g</a>
RA Product Information	<a href="https://www.renesas.com/ra">renesas.com/ra</a>
RA Product Support Forum	<a href="https://www.renesas.com/ra/forum">renesas.com/ra/forum</a>
Renesas Support	<a href="https://www.renesas.com/support">renesas.com/support</a>

**Revision History**

Rev.	Date	Description	
		Page	Summary
1.00	Oct.02.19	—	Initial release
1.01	Jan.30.20	—	Second release
1.02	Feb.24.26	34	Updated section 10

---

EK-RA6M3G v1 – User's Manual

Publication Date: Feb.24.26

Published by: Renesas Electronics Corporation

---

# EK-RA6M3G v1 – User's Manual