

RL78/G13

User's Manual: Hardware

16-Bit Single-Chip Microcontrollers

All information contained in these materials, including products and product specifications, represents information on the product at the time of publication and is subject to change by Renesas Electronics Corp. without notice. Please review the latest information published by Renesas Electronics Corp. through various means, including the Renesas Electronics Corp. website (<http://www.renesas.com>).

Notice

1. Descriptions of circuits, software and other related information in this document are provided only to illustrate the operation of semiconductor products and application examples. You are fully responsible for the incorporation or any other use of the circuits, software, and information in the design of your product or system. Renesas Electronics disclaims any and all liability for any losses and damages incurred by you or third parties arising from the use of these circuits, software, or information.
2. Renesas Electronics hereby expressly disclaims any warranties against and liability for infringement or any other claims involving patents, copyrights, or other intellectual property rights of third parties, by or arising from the use of Renesas Electronics products or technical information described in this document, including but not limited to, the product data, drawings, charts, programs, algorithms, and application examples.
3. No license, express, implied or otherwise, is granted hereby under any patents, copyrights or other intellectual property rights of Renesas Electronics or others.
4. You shall be responsible for determining what licenses are required from any third parties, and obtaining such licenses for the lawful import, export, manufacture, sales, utilization, distribution or other disposal of any products incorporating Renesas Electronics products, if required.
5. You shall not alter, modify, copy, or reverse engineer any Renesas Electronics product, whether in whole or in part. Renesas Electronics disclaims any and all liability for any losses or damages incurred by you or third parties arising from such alteration, modification, copying or reverse engineering.
6. Renesas Electronics products are classified according to the following two quality grades: "Standard" and "High Quality". The intended applications for each Renesas Electronics product depends on the product's quality grade, as indicated below.

"Standard": Computers; office equipment; communications equipment; test and measurement equipment; audio and visual equipment; home electronic appliances; machine tools; personal electronic equipment; industrial robots; etc.

"High Quality": Transportation equipment (automobiles, trains, ships, etc.); traffic control (traffic lights); large-scale communication equipment; key financial terminal systems; safety control equipment; etc.

Unless expressly designated as a high reliability product or a product for harsh environments in a Renesas Electronics data sheet or other Renesas Electronics document, Renesas Electronics products are not intended or authorized for use in products or systems that may pose a direct threat to human life or bodily injury (artificial life support devices or systems; surgical implantations; etc.), or may cause serious property damage (space system; undersea repeaters; nuclear power control systems; aircraft control systems; key plant systems; military equipment; etc.). Renesas Electronics disclaims any and all liability for any damages or losses incurred by you or any third parties arising from the use of any Renesas Electronics product that is inconsistent with any Renesas Electronics data sheet, user's manual or other Renesas Electronics document.

7. No semiconductor product is absolutely secure. Notwithstanding any security measures or features that may be implemented in Renesas Electronics hardware or software products, Renesas Electronics shall have absolutely no liability arising out of any vulnerability or security breach, including but not limited to any unauthorized access to or use of a Renesas Electronics product or a system that uses a Renesas Electronics product. RENESAS ELECTRONICS DOES NOT WARRANT OR GUARANTEE THAT RENESAS ELECTRONICS PRODUCTS, OR ANY SYSTEMS CREATED USING RENESAS ELECTRONICS PRODUCTS WILL BE INVULNERABLE OR FREE FROM CORRUPTION, ATTACK, VIRUSES, INTERFERENCE, HACKING, DATA LOSS OR THEFT, OR OTHER SECURITY INTRUSION ("Vulnerability Issues"). RENESAS ELECTRONICS DISCLAIMS ANY AND ALL RESPONSIBILITY OR LIABILITY ARISING FROM OR RELATED TO ANY VULNERABILITY ISSUES. FURTHERMORE, TO THE EXTENT PERMITTED BY APPLICABLE LAW, RENESAS ELECTRONICS DISCLAIMS ANY AND ALL WARRANTIES, EXPRESS OR IMPLIED, WITH RESPECT TO THIS DOCUMENT AND ANY RELATED OR ACCOMPANYING SOFTWARE OR HARDWARE, INCLUDING BUT NOT LIMITED TO THE IMPLIED WARRANTIES OF MERCHANTABILITY, OR FITNESS FOR A PARTICULAR PURPOSE.
8. When using Renesas Electronics products, refer to the latest product information (data sheets, user's manuals, application notes, "General Notes for Handling and Using Semiconductor Devices" in the reliability handbook, etc.), and ensure that usage conditions are within the ranges specified by Renesas Electronics with respect to maximum ratings, operating power supply voltage range, heat dissipation characteristics, installation, etc. Renesas Electronics disclaims any and all liability for any malfunctions, failure or accident arising out of the use of Renesas Electronics products outside of such specified ranges.
9. Although Renesas Electronics endeavors to improve the quality and reliability of Renesas Electronics products, semiconductor products have specific characteristics, such as the occurrence of failure at a certain rate and malfunctions under certain use conditions. Unless designated as a high reliability product or a product for harsh environments in a Renesas Electronics data sheet or other Renesas Electronics document, Renesas Electronics products are not subject to radiation resistance design. You are responsible for implementing safety measures to guard against the possibility of bodily injury, injury or damage caused by fire, and/or danger to the public in the event of a failure or malfunction of Renesas Electronics products, such as safety design for hardware and software, including but not limited to redundancy, fire control and malfunction prevention, appropriate treatment for aging degradation or any other appropriate measures. Because the evaluation of microcomputer software alone is very difficult and impractical, you are responsible for evaluating the safety of the final products or systems manufactured by you.
10. Please contact a Renesas Electronics sales office for details as to environmental matters such as the environmental compatibility of each Renesas Electronics product. You are responsible for carefully and sufficiently investigating applicable laws and regulations that regulate the inclusion or use of controlled substances, including without limitation, the EU RoHS Directive, and using Renesas Electronics products in compliance with all these applicable laws and regulations. Renesas Electronics disclaims any and all liability for damages or losses occurring as a result of your noncompliance with applicable laws and regulations.
11. Renesas Electronics products and technologies shall not be used for or incorporated into any products or systems whose manufacture, use, or sale is prohibited under any applicable domestic or foreign laws or regulations. You shall comply with any applicable export control laws and regulations promulgated and administered by the governments of any countries asserting jurisdiction over the parties or transactions.
12. It is the responsibility of the buyer or distributor of Renesas Electronics products, or any other party who distributes, disposes of, or otherwise sells or transfers the product to a third party, to notify such third party in advance of the contents and conditions set forth in this document.
13. This document shall not be reprinted, reproduced or duplicated in any form, in whole or in part, without prior written consent of Renesas Electronics.
14. Please contact a Renesas Electronics sales office if you have any questions regarding the information contained in this document or Renesas Electronics products.

(Note1) "Renesas Electronics" as used in this document means Renesas Electronics Corporation and also includes its directly or indirectly controlled subsidiaries.

(Note2) "Renesas Electronics product(s)" means any product developed or manufactured by or for Renesas Electronics.

(Rev.5.0-1 October 2020)

Corporate Headquarters

TOYOSU FORESIA, 3-2-24 Toyosu,
Koto-ku, Tokyo 135-0061, Japan
www.renesas.com

Trademarks

Renesas and the Renesas logo are trademarks of Renesas Electronics Corporation. All trademarks and registered trademarks are the property of their respective owners.

Contact Information

For further information on a product, technology, the most up-to-date version of a document, or your nearest sales office, please visit:
www.renesas.com/contact/

General Precautions in the Handling of Microprocessing Unit and Microcontroller Unit Products

The following usage notes are applicable to all Microprocessing unit and Microcontroller unit products from Renesas. For detailed usage notes on the products covered by this document, refer to the relevant sections of the document as well as any technical updates that have been issued for the products.

1. Precaution against Electrostatic Discharge (ESD)

A strong electrical field, when exposed to a CMOS device, can cause destruction of the gate oxide and ultimately degrade the device operation. Steps must be taken to stop the generation of static electricity as much as possible, and quickly dissipate it when it occurs. Environmental control must be adequate. When it is dry, a humidifier should be used. This is recommended to avoid using insulators that can easily build up static electricity. Semiconductor devices must be stored and transported in an anti-static container, static shielding bag or conductive material. All test and measurement tools including work benches and floors must be grounded. The operator must also be grounded using a wrist strap. Semiconductor devices must not be touched with bare hands. Similar precautions must be taken for printed circuit boards with mounted semiconductor devices.

2. Processing at power-on

The state of the product is undefined at the time when power is supplied. The states of internal circuits in the LSI are indeterminate and the states of register settings and pins are undefined at the time when power is supplied. In a finished product where the reset signal is applied to the external reset pin, the states of pins are not guaranteed from the time when power is supplied until the reset process is completed. In a similar way, the states of pins in a product that is reset by an on-chip power-on reset function are not guaranteed from the time when power is supplied until the power reaches the level at which resetting is specified.

3. Input of signal during power-off state

Do not input signals or an I/O pull-up power supply while the device is powered off. The current injection that results from input of such a signal or I/O pull-up power supply may cause malfunction and the abnormal current that passes in the device at this time may cause degradation of internal elements. Follow the guideline for input signal during power-off state as described in your product documentation.

4. Handling of unused pins

Handle unused pins in accordance with the directions given under handling of unused pins in the manual. The input pins of CMOS products are generally in the high-impedance state. In operation with an unused pin in the open-circuit state, extra electromagnetic noise is induced in the vicinity of the LSI, an associated shoot-through current flows internally, and malfunctions occur due to the false recognition of the pin state as an input signal become possible.

5. Clock signals

After applying a reset, only release the reset line after the operating clock signal becomes stable. When switching the clock signal during program execution, wait until the target clock signal is stabilized. When the clock signal is generated with an external resonator or from an external oscillator during a reset, ensure that the reset line is only released after full stabilization of the clock signal. Additionally, when switching to a clock signal produced with an external resonator or by an external oscillator while program execution is in progress, wait until the target clock signal is stable.

6. Voltage application waveform at input pin

Waveform distortion due to input noise or a reflected wave may cause malfunction. If the input of the CMOS device stays in the area between V_{IL} (Max.) and V_{IH} (Min.) due to noise, for example, the device may malfunction. Take care to prevent chattering noise from entering the device when the input level is fixed, and also in the transition period when the input level passes through the area between V_{IL} (Max.) and V_{IH} (Min.).

7. Prohibition of access to reserved addresses

Access to reserved addresses is prohibited. The reserved addresses are provided for possible future expansion of functions. Do not access these addresses as the correct operation of the LSI is not guaranteed.

8. Differences between products

Before changing from one product to another, for example to a product with a different part number, confirm that the change will not lead to problems. The characteristics of a microprocessing unit or microcontroller unit products in the same group but having a different part number might differ in terms of internal memory capacity, layout pattern, and other factors, which can affect the ranges of electrical characteristics, such as characteristic values, operating margins, immunity to noise, and amount of radiated noise. When changing to a product with a different part number, implement a system-evaluation test for the given product.

How to Use This Manual

Readers

This manual is intended for user engineers who wish to understand the functions of the RL78/G13 and design and develop application systems and programs for these devices. The target products are as follows.

- 20-pin: R5F1006x (x = A, C, D, E)
R5F1016x (x = A, C, D, E)
- 24-pin: R5F1007x (x = A, C, D, E)
R5F1017x (x = A, C, D, E)
- 25-pin: R5F1008x (x = A, C, D, E)
R5F1018x (x = A, C, D, E)
- 30-pin: R5F100Ax (x = A, C, D, E, F, G)
R5F101Ax (x = A, C, D, E, F, G)
- 32-pin: R5F100Bx (x = A, C, D, E, F, G)
R5F101Bx (x = A, C, D, E, F, G)
- 36-pin: R5F100Cx (x = A, C, D, E, F, G)
R5F101Cx (x = A, C, D, E, F, G)
- 40-pin: R5F100Ex (x = A, C, D, E, F, G, H)
R5F101Ex (x = A, C, D, E, F, G, H)
- 44-pin: R5F100Fx (x = A, C, D, E, F, G, H, J, K, L)
R5F101Fx (x = A, C, D, E, F, G, H, J, K, L)
- 48-pin: R5F100Gx (x = A, C, D, E, F, G, H, J, K, L)
R5F101Gx (x = A, C, D, E, F, G, H, J, K, L)
- 52-pin: R5F100Jx (x = C, D, E, F, G, H, J, K, L)
R5F101Jx (x = C, D, E, F, G, H, J, K, L)
- 64-pin: R5F100Lx (x = C, D, E, F, G, H, J, K, L)
R5F101Lx (x = C, D, E, F, G, H, J, K, L)
- 80-pin: R5F100Mx (x = F, G, H, J, K, L)
R5F101Mx (x = F, G, H, J, K, L)
- 100-pin: R5F100Px (x = F, G, H, J, K, L)
R5F101Px (x = F, G, H, J, K, L)
- 128-pin: R5F100Sx (x = H, J, K, L)
R5F101Sx (x = H, J, K, L)

Purpose

This manual is intended to give users an understanding of the functions described in the **Organization** below.

Organization

The RL78/G13 manual is separated into two parts: this manual and the instructions edition (common to the RL78 Microcontroller).

**RL78/G13
User's Manual
(This Manual)**

**RL78 Microcontroller
User's Manual
Software**

- Pin functions
- Internal block functions
- Interrupts
- Other on-chip peripheral functions
- Electrical specifications
- CPU functions
- Instruction set
- Explanation of each instruction

How to Read This Manual

It is assumed that the readers of this manual have general knowledge of electrical engineering, logic circuits, and microcontrollers.

- To gain a general understanding of functions:
 - Read this manual in the order of the **CONTENTS**. The mark "<R>" shows major revised points. The revised points can be easily searched by copying an "<R>" in the PDF file and specifying it in the "Find what:" field.
- How to interpret the register format:
 - For a bit number enclosed in angle brackets, the bit name is defined as a reserved word in the assembler, and is defined as an sfr variable using the #pragma sfr directive in the compiler.

- To know details of the RL78 Microcontroller instructions:
→ Refer to the separate document **RL78 Family User's Manual: Software (R01US0015E)**.

Conventions

Data significance:	Higher digits on the left and lower digits on the right
Active low representations:	\overline{xxx} (overscore over pin and signal name)
Note:	Footnote for item marked with Note in the text
Caution:	Information requiring particular attention
Remark:	Supplementary information
Numerical representations:	Binary ...xxxx or xxxxB
	Decimal ...xxxx
	Hexadecimal ...xxxxH

Related Documents

The related documents indicated in this publication may include preliminary versions. However, preliminary versions are not marked as such.

Documents Related to Devices

Document Name	Document No.
RL78/G13 User's Manual Hardware	This manual
RL78 Family User's Manual: Software	R01US0015E

Documents Related to Flash Memory Programming

Document Name	Document No.
PG-FP5 Flash Memory Programmer User's Manual	—
RL78, 78K, V850, RX100, RX200, RX600 (Except RX64x), R8C, SH	R20UT2923E
Common	R20UT2922E
Setup Manual	R20UT0930E
PG-FP6 Flash Memory Programmer User's Manual	R20UT4025E
E1, E20 Emulator User's Manual	R20UT0398E
E2 Emulator User's Manual	R20UT3538E
E2 Lite Emulator User's Manual	R20UT3240E
Renesas Flash Programmer Flash Memory Programming Software User's Manual	R20UT4066E
Renesas Flash Development Toolkit User's Manual	R20UT0508E

Caution The related documents listed above are subject to change without notice. Be sure to use the latest version of each document when designing.

Other Documents

Document Name	Document No.
Renesas Microcontrollers RL78 Family	R01CP0003E
Semiconductor Package Mount Manual	R50ZZ0003E
Semiconductor Reliability Handbook	R51ZZ0001E

Caution The related documents listed above are subject to change without notice. Be sure to use the latest version of each document when designing.

All trademarks and registered trademarks are the property of their respective owners.

EEPROM is a trademark of Renesas Electronics Corporation.

SuperFlash is a registered trademark of Silicon Storage Technology, Inc. in several countries including the United States and Japan.

Caution: This product uses SuperFlash® technology licensed from Silicon Storage Technology, Inc.
--

CONTENTS

CHAPTER 1 OUTLINE.....	1
1.1 Features.....	1
1.2 List of Part Numbers	4
1.3 Pin Configuration (Top View)	13
1.3.1 20-pin products.....	13
1.3.2 24-pin products.....	14
1.3.3 25-pin products.....	15
1.3.4 30-pin products.....	16
1.3.5 32-pin products.....	17
1.3.6 36-pin products.....	18
1.3.7 40-pin products.....	19
1.3.8 44-pin products.....	20
1.3.9 48-pin products.....	21
1.3.10 52-pin products.....	23
1.3.11 64-pin products.....	24
1.3.12 80-pin products.....	26
1.3.13 100-pin products.....	27
1.3.14 128-pin products.....	29
1.4 Pin Identification.....	30
1.5 Block Diagram	31
1.5.1 20-pin products.....	31
1.5.2 24-pin products.....	32
1.5.3 25-pin products.....	33
1.5.4 30-pin products.....	34
1.5.5 32-pin products.....	35
1.5.6 36-pin products.....	36
1.5.7 40-pin products.....	37
1.5.8 44-pin products.....	38
1.5.9 48-pin products.....	39
1.5.10 52-pin products.....	40
1.5.11 64-pin products.....	41
1.5.12 80-pin products.....	42
1.5.13 100-pin products.....	43
1.5.14 128-pin products.....	44
1.6 Outline of Functions.....	45
CHAPTER 2 PIN FUNCTIONS	51
2.1 Port Function	51

2.1.1	20-pin products.....	52
2.1.2	24-pin products.....	54
2.1.3	25-pin products.....	56
2.1.4	30-pin products.....	58
2.1.5	32-pin products.....	60
2.1.6	36-pin products.....	62
2.1.7	40-pin products.....	64
2.1.8	44-pin products.....	66
2.1.9	48-pin products.....	68
2.1.10	52-pin products.....	70
2.1.11	64-pin products.....	72
2.1.12	80-pin products.....	74
2.1.13	100-pin products.....	77
2.1.14	128-pin products.....	81
2.2	Functions other than port pins	85
2.2.1	Functions for each product.....	85
2.2.2	Pins for each product (pins other than port pins).....	90
2.3	Connection of Unused Pins	92
2.4	Block Diagrams of Pins	93
CHAPTER 3	CPU ARCHITECTURE	105
3.1	Memory Space	105
3.1.1	Internal program memory space.....	121
3.1.2	Mirror area.....	124
3.1.3	Internal data memory space.....	126
3.1.4	Special function register (SFR) area	127
3.1.5	Extended special function register (2nd SFR: 2nd Special Function Register) area	127
3.1.6	Data memory addressing	128
3.2	Processor Registers.....	129
3.2.1	Control registers	129
3.2.2	General-purpose registers.....	131
3.2.3	ES and CS registers.....	132
3.2.4	Special function registers (SFRs).....	133
3.2.5	Extended special function registers (2nd SFRs: 2nd Special Function Registers)	140
3.3	Instruction Address Addressing.....	149
3.3.1	Relative addressing.....	149
3.3.2	Immediate addressing.....	149
3.3.3	Table indirect addressing	150
3.3.4	Register indirect addressing.....	151
3.4	Addressing for Processing Data Addresses	152
3.4.1	Implied addressing	152

3.4.2 Register addressing	152
3.4.3 Direct addressing	153
3.4.4 Short direct addressing	154
3.4.5 SFR addressing.....	155
3.4.6 Register indirect addressing	156
3.4.7 Based addressing.....	157
3.4.8 Based indexed addressing	161
3.4.9 Stack addressing.....	162
CHAPTER 4 PORT FUNCTIONS	166
4.1 Port Functions	166
4.2 Port Configuration.....	166
4.2.1 Port 0.....	168
4.2.2 Port 1.....	168
4.2.3 Port 2.....	169
4.2.4 Port 3.....	169
4.2.5 Port 4.....	169
4.2.6 Port 5.....	170
4.2.7 Port 6.....	170
4.2.8 Port 7.....	170
4.2.9 Port 8.....	170
4.2.10 Port 9.....	171
4.2.11 Port 10.....	171
4.2.12 Port 11.....	171
4.2.13 Port 12.....	171
4.2.14 Port 13.....	172
4.2.15 Port 14.....	172
4.2.16 Port 15.....	173
4.3 Registers Controlling Port Function	174
4.3.1 Port mode registers (PMxx).....	180
4.3.2 Port registers (Pxx).....	182
4.3.3 Pull-up resistor option registers (PUxx).....	184
4.3.4 Port input mode registers (PIMxx).....	185
4.3.5 Port output mode registers (POMxx).....	186
4.3.6 Port mode control registers (PMCxx).....	187
4.3.7 A/D port configuration register (ADPC).....	188
4.3.8 Peripheral I/O redirection register (PIOR).....	189
4.3.9 Global digital input disable register (GDIDIS).....	191
4.4 Port Function Operations	192
4.4.1 Writing to I/O port	192
4.4.2 Reading from I/O port.....	192

4.4.3 Operations on I/O port.....	192
4.4.4 Handling different potential (1.8 V, 2.5 V, 3 V) by using $EV_{DD} \leq V_{DD}$	193
4.4.5 Handling different potential (1.8 V, 2.5 V, 3 V) by using I/O buffers	193
4.5 Register Settings When Using Alternate Function	196
4.5.1 Basic concept when using alternate function.....	196
4.5.2 Register settings for alternate function whose output function is not used	197
4.5.3 Register setting examples for used port and alternate functions	198
4.6 Cautions When Using Port Function.....	219
4.6.1 Cautions on 1-Bit Manipulation Instruction for Port Register n (Pn)	219
4.6.2 Notes on specifying the pin settings	220
 CHAPTER 5 CLOCK GENERATOR	 221
5.1 Functions of Clock Generator	221
5.2 Configuration of Clock Generator	223
5.3 Registers Controlling Clock Generator.....	225
5.3.1 Clock operation mode control register (CMC)	225
5.3.2 System clock control register (CKC).....	228
5.3.3 Clock operation status control register (CSC)	229
5.3.4 Oscillation stabilization time counter status register (OSTC).....	230
5.3.5 Oscillation stabilization time select register (OSTS).....	232
5.3.6 Peripheral enable register 0 (PER0).....	234
5.3.7 Subsystem clock supply mode control register (OSMC)	237
5.3.8 High-speed on-chip oscillator frequency select register (HOCODIV)	238
5.3.9 High-speed on-chip oscillator trimming register (HIOTRM)	239
5.4 System Clock Oscillator	240
5.4.1 X1 oscillator.....	240
5.4.2 XT1 oscillator.....	240
5.4.3 High-speed on-chip oscillator	244
5.4.4 Low-speed on-chip oscillator	244
5.5 Clock Generator Operation	245
5.6 Controlling Clock.....	247
5.6.1 Example of setting high-speed on-chip oscillator	247
5.6.2 Example of setting X1 oscillation clock.....	248
5.6.3 Example of setting XT1 oscillation clock	249
5.6.4 CPU clock status transition diagram.....	250
5.6.5 Condition before changing CPU clock and processing after changing CPU clock	256
5.6.6 Time required for switchover of CPU clock and system clock	258
5.6.7 Conditions before clock oscillation is stopped	259
5.7 Resonator and Oscillator Constants	260

CHAPTER 6	TIMER ARRAY UNIT	264
6.1	Functions of Timer Array Unit	266
6.1.1	Independent channel operation function	266
6.1.2	Simultaneous channel operation function	267
6.1.3	8-bit timer operation function (channels 1 and 3 only)	268
6.1.4	LIN-bus supporting function (channel 7 of unit 0 only)	269
6.2	Configuration of Timer Array Unit	270
6.2.1	Timer count register mn (TCRmn)	275
6.2.2	Timer data register mn (TDRmn)	277
6.3	Registers Controlling Timer Array Unit	278
6.3.1	Peripheral enable register 0 (PER0)	279
6.3.2	Timer clock select register m (TPSm)	280
6.3.3	Timer mode register mn (TMRmn)	283
6.3.4	Timer status register mn (TSRmn)	289
6.3.5	Timer channel enable status register m (TEm)	290
6.3.6	Timer channel start register m (TSm)	291
6.3.7	Timer channel stop register m (TTm)	292
6.3.8	Timer input select register 0 (TIS0)	293
6.3.9	Timer output enable register m (TOEm)	294
6.3.10	Timer output register m (TOm)	295
6.3.11	Timer output level register m (TOLm)	296
6.3.12	Timer output mode register m (TOMm)	297
6.3.13	Input switch control register (ISC)	298
6.3.14	Noise filter enable registers 1, 2 (NFEN1, NFEN2)	299
6.3.15	Registers controlling port functions of pins to be used for timer I/O	302
6.4	Basic Rules of Timer Array Unit	303
6.4.1	Basic rules of simultaneous channel operation function	303
6.4.2	Basic rules of 8-bit timer operation function (channels 1 and 3 only)	305
6.5	Operation of Counter	306
6.5.1	Count clock (f_{CLK})	306
6.5.2	Start timing of counter	308
6.5.3	Operation of counter	309
6.6	Channel Output (TOmn pin) Control	314
6.6.1	TOmn pin output circuit configuration	314
6.6.2	TOmn Pin Output Setting	315
6.6.3	Cautions on Channel Output Operation	316
6.6.4	Collective manipulation of TOmn bit	321
6.6.5	Timer Interrupt and TOmn Pin Output at Operation Start	322
6.7	Timer Input (TImn) Control	323
6.7.1	TImn input circuit configuration	323

6.7.2 Noise filter	323
6.7.3 Cautions on channel input operation	324
6.8 Independent Channel Operation Function of Timer Array Unit.....	325
6.8.1 Operation as interval timer/square wave output	325
6.8.2 Operation as external event counter	331
6.8.3 Operation as frequency divider (channel 0 of unit 0 only)	336
6.8.4 Operation as input pulse interval measurement	340
6.8.5 Operation as input signal high-/low-level width measurement	344
6.8.6 Operation as delay counter	348
6.9 Simultaneous Channel Operation Function of Timer Array Unit	353
6.9.1 Operation as one-shot pulse output function	353
6.9.2 Operation as PWM function.....	360
6.9.3 Operation as multiple PWM output function	367
6.10 Cautions When Using Timer Array Unit.....	375
6.10.1 Cautions When Using Timer Output.....	375
CHAPTER 7 REAL-TIME CLOCK.....	376
7.1 Functions of Real-time Clock.....	376
7.2 Configuration of Real-time Clock	376
7.3 Registers Controlling Real-time Clock.....	378
7.3.1 Peripheral enable register 0 (PER0).....	379
7.3.2 Subsystem clock supply mode control register (OSMC)	380
7.3.3 Real-time clock control register 0 (RTCC0).....	381
7.3.4 Real-time clock control register 1 (RTCC1).....	382
7.3.5 Second count register (SEC).....	384
7.3.6 Minute count register (MIN).....	384
7.3.7 Hour count register (HOUR).....	385
7.3.8 Day count register (DAY).....	387
7.3.9 Week count register (WEEK).....	388
7.3.10 Month count register (MONTH)	389
7.3.11 Year count register (YEAR).....	389
7.3.12 Watch error correction register (SUBCUD).....	390
7.3.13 Alarm minute register (ALARMWWM)	391
7.3.14 Alarm hour register (ALARMWH)	391
7.3.15 Alarm week register (ALARMWW)	391
7.3.16 Port mode register 3 (PM3)	392
7.3.17 Port register 3 (P3)	392
7.4 Real-time Clock Operation	393
7.4.1 Starting operation of real-time clock	393
7.4.2 Shifting to HALT/STOP mode after starting operation	394
7.4.3 Reading/writing real-time clock.....	395

7.4.4	Setting alarm of real-time clock	397
7.4.5	1 Hz output of real-time clock	398
7.4.6	Example of watch error correction of real-time clock	399
CHAPTER 8	12-BIT INTERVAL TIMER	404
8.1	Functions of 12-bit Interval Timer	404
8.2	Configuration of 12-bit Interval Timer	404
8.3	Registers Controlling 12-bit Interval Timer	405
8.3.1	Peripheral enable register 0 (PER0)	405
8.3.2	Subsystem clock supply mode control register (OSMC)	406
8.3.3	Interval timer control register (ITMC)	407
8.4	12-bit Interval Timer Operation	408
8.4.1	12-bit interval timer operation timing	408
8.4.2	Start of count operation and re-enter to HALT/STOP mode after returned from HALT/STOP mode	409
CHAPTER 9	CLOCK OUTPUT/BUZZER OUTPUT CONTROLLER	410
9.1	Functions of Clock Output/Buzzer Output Controller	410
9.2	Configuration of Clock Output/Buzzer Output Controller	412
9.3	Registers Controlling Clock Output/Buzzer Output Controller	412
9.3.1	Clock output select registers n (CKSn)	412
9.3.2	Registers controlling port functions of pins to be used for clock or buzzer output	414
9.4	Operations of Clock Output/Buzzer Output Controller	415
9.4.1	Operation as output pin	415
9.5	Cautions of clock output/buzzer output controller	415
CHAPTER 10	WATCHDOG TIMER	416
10.1	Functions of Watchdog Timer	416
10.2	Configuration of Watchdog Timer	417
10.3	Register Controlling Watchdog Timer	418
10.3.1	Watchdog timer enable register (WDTE)	418
10.4	Operation of Watchdog Timer	419
10.4.1	Controlling operation of watchdog timer	419
10.4.2	Setting overflow time of watchdog timer	421
10.4.3	Setting window open period of watchdog timer	422
10.4.4	Setting watchdog timer interval interrupt	424
CHAPTER 11	A/D CONVERTER	425
11.1	Function of A/D Converter	425
11.2	Configuration of A/D Converter	428

11.3 Registers Controlling A/D Converter	430
11.3.1 Peripheral enable register 0 (PER0).....	431
11.3.2 A/D converter mode register 0 (ADM0)	432
11.3.3 A/D converter mode register 1 (ADM1)	441
11.3.4 A/D converter mode register 2 (ADM2)	442
11.3.5 10-bit A/D conversion result register (ADCR).....	444
11.3.6 8-bit A/D conversion result register (ADCRH)	445
11.3.7 Analog input channel specification register (ADS).....	446
11.3.8 Conversion result comparison upper limit setting register (ADUL)	448
11.3.9 Conversion result comparison lower limit setting register (ADLL)	448
11.3.10 A/D test register (ADTES)	449
11.3.11 Registers controlling port function of analog input pins	450
11.4 A/D Converter Conversion Operations	451
11.5 Input Voltage and Conversion Results	453
11.6 A/D Converter Operation Modes	454
11.6.1 Software trigger mode (select mode, sequential conversion mode).....	454
11.6.2 Software trigger mode (select mode, one-shot conversion mode)	455
11.6.3 Software trigger mode (scan mode, sequential conversion mode).....	456
11.6.4 Software trigger mode (scan mode, one-shot conversion mode)	457
11.6.5 Hardware trigger no-wait mode (select mode, sequential conversion mode).....	458
11.6.6 Hardware trigger no-wait mode (select mode, one-shot conversion mode).....	459
11.6.7 Hardware trigger no-wait mode (scan mode, sequential conversion mode).....	460
11.6.8 Hardware trigger no-wait mode (scan mode, one-shot conversion mode)	461
11.6.9 Hardware trigger wait mode (select mode, sequential conversion mode)	462
11.6.10 Hardware trigger wait mode (select mode, one-shot conversion mode).....	463
11.6.11 Hardware trigger wait mode (scan mode, sequential conversion mode).....	464
11.6.12 Hardware trigger wait mode (scan mode, one-shot conversion mode)	465
11.7 A/D Converter Setup Flowchart	466
11.7.1 Setting up software trigger mode.....	466
11.7.2 Setting up hardware trigger no-wait mode.....	467
11.7.3 Setting up hardware trigger wait mode	468
11.7.4 Setup when temperature sensor output voltage/internal reference voltage is selected (example for software trigger mode and one-shot conversion mode).....	469
11.7.5 Setting up test mode	470
11.8 SNOOZE Mode Function	471
11.9 How to Read A/D Converter Characteristics Table	475
11.10 Cautions for A/D Converter	477
 CHAPTER 12 SERIAL ARRAY UNIT	 481
12.1 Functions of Serial Array Unit	483
12.1.1 Simplified SPI (CSI00, CSI01, CSI10, CSI11, CSI20, CSI21, CSI30, CSI31)	483

12.1.2	UART (UART0 to UART3).....	484
12.1.3	Simplified I ² C (IIC00, IIC01, IIC10, IIC11, IIC20, IIC21, IIC30, IIC31)	485
12.2	Configuration of Serial Array Unit	486
12.2.1	Shift register	490
12.2.2	Lower 8/9 bits of the serial data register mn (SDRmn).....	490
12.3	Registers Controlling Serial Array Unit.....	492
12.3.1	Peripheral enable register 0 (PER0).....	493
12.3.2	Serial clock select register m (SPSm)	494
12.3.3	Serial mode register mn (SMRmn).....	495
12.3.4	Serial communication operation setting register mn (SCRmn)	497
12.3.5	Serial data register mn (SDRmn)	500
12.3.6	Serial flag clear trigger register mn (SIRmn)	502
12.3.7	Serial status register mn (SSRmn).....	503
12.3.8	Serial channel start register m (SSm).....	505
12.3.9	Serial channel stop register m (STm)	506
12.3.10	Serial channel enable status register m (SEm)	507
12.3.11	Serial output enable register m (SOEm).....	508
12.3.12	Serial output register m (SOM).....	509
12.3.13	Serial output level register m (SOLm)	510
12.3.14	Serial standby control register m (SSCm)	512
12.3.15	Input switch control register (ISC)	513
12.3.16	Noise filter enable register 0 (NFEN0).....	514
12.3.17	Registers controlling port functions of serial input/output pins.....	515
12.4	Operation Stop Mode	516
12.4.1	Stopping the operation by units	516
12.4.2	Stopping the operation by channels	517
12.5	Operation of Simplified SPI (CSI00, CSI01, CSI10, CSI11, CSI20, CSI21, CSI30, CSI31)	
	Communication	518
12.5.1	Master transmission	521
12.5.2	Master reception.....	531
12.5.3	Master transmission/reception.....	540
12.5.4	Slave transmission	550
12.5.5	Slave reception.....	560
12.5.6	Slave transmission/reception.....	567
12.5.7	SNOOZE mode function.....	577
12.5.8	Calculating transfer clock frequency.....	581
12.5.9	Procedure for processing errors that occurred during simplified SPI (CSI00, CSI01, CSI10, CSI11, CSI20, CSI21, CSI30, CSI31) communication.....	583
12.6	Operation of UART (UART0 to UART3) Communication.....	584
12.6.1	UART transmission	587
12.6.2	UART reception	597

12.6.3 SNOOZE mode function.....	604
12.6.4 Calculating baud rate	612
12.6.5 Procedure for processing errors that occurred during UART (UART0 to UART3) communication	616
12.7 LIN Communication Operation	617
12.7.1 LIN transmission.....	617
12.7.2 LIN reception	620
12.8 Operation of Simplified I²C (IIC00, IIC01, IIC10, IIC11, IIC20, IIC21, IIC30, IIC31) Communication	626
12.8.1 Address field transmission.....	629
12.8.2 Data transmission.....	635
12.8.3 Data reception	639
12.8.4 Stop condition generation.....	644
12.8.5 Calculating transfer rate	645
12.8.6 Procedure for processing errors that occurred during simplified I ² C (IIC00, IIC01, IIC10, IIC11, IIC20, IIC21, IIC30, IIC31) communication	647
CHAPTER 13 SERIAL INTERFACE IICA	648
13.1 Functions of Serial Interface IICA.....	648
13.2 Configuration of Serial Interface IICA	651
13.3 Registers Controlling Serial Interface IICA.....	654
13.3.1 Peripheral enable register 0 (PER0).....	654
13.3.2 IICA control register n0 (IICCTLn0)	655
13.3.3 IICA status register n (IICSn).....	660
13.3.4 IICA flag register n (IICFn).....	662
13.3.5 IICA control register n1 (IICCTLn1)	664
13.3.6 IICA low-level width setting register n (IICWLn)	666
13.3.7 IICA high-level width setting register n (IICWHn)	666
13.3.8 Port mode register 6 (PM6)	667
13.4 I²C Bus Mode Functions	668
13.4.1 Pin configuration.....	668
13.4.2 Setting transfer clock by using IICWLn and IICWHn registers.....	669
13.5 I²C Bus Definitions and Control Methods	671
13.5.1 Start conditions.....	671
13.5.2 Addresses	672
13.5.3 Transfer direction specification.....	672
13.5.4 Acknowledge (ACK)	673
13.5.5 Stop condition.....	674
13.5.6 Clock stretch.....	675
13.5.7 Canceling clock stretch.....	677
13.5.8 Interrupt request (INTIICAn) generation timing and clock stretch control	678

13.5.9	Address match detection method	679
13.5.10	Error detection	679
13.5.11	Extension code	679
13.5.12	Arbitration	680
13.5.13	Wakeup function	682
13.5.14	Communication reservation	685
13.5.15	Cautions	689
13.5.16	Communication operations	690
13.5.17	Timing of I ² C interrupt request (INTIICAn) occurrence	697
13.6	Timing Charts	718
CHAPTER 14	MULTIPLIER AND DIVIDER/MULTIPLY-ACCUMULATOR	733
14.1	Functions of Multiplier and Divider/Multiply-Accumulator	733
14.2	Configuration of Multiplier and Divider/Multiply-Accumulator	733
14.2.1	Multiplication/division data register A (MDAH, MDAL)	735
14.2.2	Multiplication/division data register B (MDBL, MDBH)	736
14.2.3	Multiplication/division data register C (MDCL, MDCH)	737
14.3	Register Controlling Multiplier and Divider/Multiply-Accumulator	739
14.3.1	Multiplication/division control register (MDUC)	739
14.4	Operations of Multiplier and Divider/Multiply-Accumulator	741
14.4.1	Multiplication (unsigned) operation	741
14.4.2	Multiplication (signed) operation	742
14.4.3	Multiply-accumulation (unsigned) operation	743
14.4.4	Multiply-accumulation (signed) operation	745
14.4.5	Division operation	747
CHAPTER 15	DMA CONTROLLER	749
15.1	Functions of DMA Controller	749
15.2	Configuration of DMA Controller	750
15.2.1	DMA SFR address register n (DSAn)	750
15.2.2	DMA RAM address register n (DRAn)	751
15.2.3	DMA byte count register n (DBCn)	752
15.3	Registers Controlling DMA Controller	753
15.3.1	DMA mode control register n (DMCn)	753
15.3.2	DMA operation control register n (DRCn)	756
15.4	Operation of DMA Controller	757
15.4.1	Operation procedure	757
15.4.2	Transfer mode	758
15.4.3	Termination of DMA transfer	758
15.5	Example of Setting of DMA Controller	759
15.5.1	Simplified SPI (CSI) consecutive transmission	759

15.5.2	Consecutive capturing of A/D conversion results	761
15.5.3	UART consecutive reception + ACK transmission.....	763
15.5.4	Holding DMA transfer pending by DWAITn bit	764
15.5.5	Forced termination by software	765
15.6	Cautions on Using DMA Controller	767
CHAPTER 16	INTERRUPT FUNCTIONS.....	770
16.1	Interrupt Function Types	770
16.2	Interrupt Sources and Configuration	770
16.3	Registers Controlling Interrupt Functions.....	777
16.3.1	Interrupt request flag registers (IF0L, IF0H, IF1L, IF1H, IF2L, IF2H, IF3L)	781
16.3.2	Interrupt mask flag registers (MK0L, MK0H, MK1L, MK1H, MK2L, MK2H, MK3L).....	782
16.3.3	Priority specification flag registers (PR00L, PR00H, PR01L, PR01H, PR02L, PR02H, PR03L, PR10L, PR10H, PR11L, PR11H, PR12L, PR12H, PR13L).....	784
16.3.4	External interrupt rising edge enable registers (EGP0, EGP1), external interrupt falling edge enable registers (EGN0, EGN1).....	787
16.3.5	Program status word (PSW).....	789
16.4	Interrupt Servicing Operations	790
16.4.1	Maskable interrupt request acknowledgment	790
16.4.2	Software interrupt request acknowledgment	793
16.4.3	Multiple interrupt servicing.....	793
16.4.4	Interrupt request hold	797
CHAPTER 17	KEY INTERRUPT FUNCTION	798
17.1	Functions of Key Interrupt	798
17.2	Configuration of Key Interrupt.....	798
17.3	Register Controlling Key Interrupt	800
17.3.1	Key return mode register (KRM).....	800
17.3.2	Port mode register 7 (PM7)	801
CHAPTER 18	STANDBY FUNCTION	802
18.1	Standby Function	802
18.2	Registers controlling standby function	803
18.3	Standby Function Operation	803
18.3.1	HALT mode	803
18.3.2	STOP mode.....	808
18.3.3	SNOOZE mode	813
CHAPTER 19	RESET FUNCTION.....	816
19.1	Timing of Reset Operation	818

19.2 States of Operation During Reset Periods.....	820
19.3 Register for Confirming Reset Source	822
19.3.1 Reset Control Flag Register (RESF)	822
CHAPTER 20 POWER-ON-RESET CIRCUIT	825
20.1 Functions of Power-on-reset Circuit	825
20.2 Configuration of Power-on-reset Circuit.....	826
20.3 Operation of Power-on-reset Circuit	826
CHAPTER 21 VOLTAGE DETECTOR.....	830
21.1 Functions of Voltage Detector	830
21.2 Configuration of Voltage Detector	831
21.3 Registers Controlling Voltage Detector	831
21.3.1 Voltage detection register (LVIM).....	832
21.3.2 Voltage detection level register (LVIS)	833
21.4 Operation of Voltage Detector	836
21.4.1 When used as reset mode.....	836
21.4.2 When used as interrupt mode	838
21.4.3 When used as interrupt & reset mode	840
21.5 Cautions for Voltage Detector.....	846
CHAPTER 22 SAFETY FUNCTIONS	848
22.1 Overview of Safety Functions	848
22.2 Registers Used by Safety Functions	849
22.3 Operation of Safety Functions	849
22.3.1 Flash memory CRC operation function (high-speed CRC).....	849
22.3.1.1 Flash memory CRC control register (CRC0CTL).....	849
22.3.1.2 Flash memory CRC operation result register (PGCRCL).....	851
22.3.2 CRC operation function (general-purpose CRC).....	853
22.3.2.1 CRC input register (CRCIN).....	853
22.3.2.2 CRC data register (CRCD).....	854
22.3.3 RAM parity error detection function	855
22.3.3.1 RAM parity error control register (RPECTL).....	855
22.3.4 RAM guard function.....	857
22.3.4.1 Invalid memory access detection control register (IAWCTL)	857
22.3.5 SFR guard function	858
22.3.5.1 Invalid memory access detection control register (IAWCTL)	858
22.3.6 Invalid memory access detection function	859
22.3.6.1 Invalid memory access detection control register (IAWCTL)	860
22.3.7 Frequency detection function	861
22.3.7.1 Timer input select register 0 (TIS0).....	862
22.3.8 A/D test function	863

22.3.8.1 A/D test register (ADTES).....	865
22.3.8.2 Analog input channel specification register (ADS)	866
CHAPTER 23 REGULATOR	868
23.1 Regulator Overview.....	868
CHAPTER 24 OPTION BYTE.....	869
24.1 Functions of Option Bytes	869
24.1.1 User option byte (000C0H to 000C2H/010C0H to 010C2H).....	869
24.1.2 On-chip debug option byte (000C3H/010C3H).....	870
24.2 Format of User Option Byte	871
24.3 Format of On-chip Debug Option Byte.....	876
24.4 Setting of Option Byte.....	877
CHAPTER 25 FLASH MEMORY	878
25.1 Serial Programming Using Flash Memory Programmer	880
25.1.1 Programming environment	882
25.1.2 Communication mode	882
25.2 Serial Programming Using External Device (that Incorporates UART)	883
25.2.1 Programming environment	883
25.2.2 Communication mode	884
25.3 Connection of Pins on Board	885
25.3.1 P40/TOOL0 pin	885
25.3.2 RESET pin.....	885
25.3.3 Port pins	886
25.3.4 REGC pin	886
25.3.5 X1 and X2 pins	886
25.3.6 Power supply	886
25.4 Serial Programming Method	887
25.4.1 Serial programming procedure	887
25.4.2 Flash memory programming mode.....	888
25.4.3 Selecting communication mode.....	890
25.4.4 Communication commands	890
25.5 Processing Time for Each Command When Dedicated Flash Memory Programmer Is in Use (Reference Value)	892
25.6 Self-Programming	893
25.6.1 Self-programming procedure.....	894
25.6.2 Boot swap function	895
25.6.3 Flash shield window function.....	897
25.7 Security Settings	898
25.8 Data Flash	900

25.8.1	Data flash overview	900
25.8.2	Register controlling data flash memory	900
25.8.2.1	Data flash control register (DFLCTL)	900
25.8.3	Procedure for accessing data flash memory	901
CHAPTER 26	ON-CHIP DEBUG FUNCTION	903
26.1	Connecting E1, E2, E2 Lite, E20 On-chip Debugging Emulator	903
26.2	On-Chip Debug Security ID	904
26.3	Securing of User Resources	904
CHAPTER 27	BCD CORRECTION CIRCUIT.....	906
27.1	BCD Correction Circuit Function	906
27.2	Registers Used by BCD Correction Circuit	906
27.2.1	BCD correction result register (BCDADJ).....	906
27.3	BCD Correction Circuit Operation	907
CHAPTER 28	INSTRUCTION SET.....	909
28.1	Conventions Used in Operation List	909
28.1.1	Operand identifiers and specification methods.....	909
28.1.2	Description of operation column	910
28.1.3	Description of flag operation column	911
28.1.4	PREFIX instruction	911
28.2	Operation List	912
CHAPTER 29	ELECTRICAL SPECIFICATIONS (T_A = -40 to +85°C).....	929
29.1	Absolute Maximum Ratings	930
29.2	Oscillator Characteristics	932
29.2.1	X1, XT1 oscillator characteristics	932
29.2.2	On-chip oscillator characteristics	932
29.3	DC Characteristics	933
29.3.1	Pin characteristics	933
29.3.2	Supply current characteristics	938
29.4	AC Characteristics	952
29.5	Peripheral Functions Characteristics.....	956
29.5.1	Serial array unit	956
29.5.2	Serial interface IICA	984
29.6	Analog Characteristics	988
29.6.1	A/D converter characteristics.....	988
29.6.2	Temperature sensor/internal reference voltage characteristics.....	993
29.6.3	POR circuit characteristics	993

29.6.4	LVD circuit characteristics	994
29.6.5	Power supply voltage rising slope characteristics	995
29.7	RAM Data Retention Characteristics	996
29.8	Flash Memory Programming Characteristics.....	996
29.9	Dedicated Flash Memory Programmer Communication (UART).....	997
29.10	Timing of Entry to Flash Memory Programming Modes	997
CHAPTER 30	ELECTRICAL SPECIFICATIONS	
	(G: INDUSTRIAL APPLICATIONS T_A = -40 to +105°C).....	998
30.1	Absolute Maximum Ratings	999
30.2	Oscillator Characteristics	1001
30.2.1	X1, XT1 oscillator characteristics	1001
30.2.2	On-chip oscillator characteristics	1001
30.3	DC Characteristics	1002
30.3.1	Pin characteristics	1002
30.3.2	Supply current characteristics	1007
30.4	AC Characteristics	1017
30.5	Peripheral Functions Characteristics.....	1020
30.5.1	Serial array unit	1020
30.5.2	Serial interface IICA	1041
30.6	Analog Characteristics	1042
30.6.1	A/D converter characteristics.....	1042
30.6.2	Temperature sensor/internal reference voltage characteristics	1047
30.6.3	POR circuit characteristics	1047
30.6.4	LVD circuit characteristics	1048
30.6.5	Power supply voltage rising slope characteristics	1048
30.7	RAM Data Retention Characteristics.....	1049
30.8	Flash Memory Programming Characteristics.....	1049
30.9	Dedicated Flash Memory Programmer Communication (UART).....	1050
30.10	Timing of Entry to Flash Memory Programming Modes	1050
CHAPTER 31	PACKAGE DRAWINGS	1051
31.1	20-pin Package	1051
31.2	24-pin Package	1053
31.3	25-pin Package	1056
31.4	30-pin Package	1057
31.5	32-pin Package	1058
31.6	36-pin Package	1061
31.7	40-pin Package	1062
31.8	44-pin Package	1065
31.9	48-pin Package	1069

31.10 52-pin Package	1075
31.11 64-pin Package	1077
31.12 80-pin Package	1083
31.13 100-pin Package	1087
31.14 128-pin Package	1091
APPENDIX A REVISION HISTORY	1092
A.1 Major Revisions in This Edition	1092
A.2 Revision History of Preceding Editions	1093

CHAPTER 1 OUTLINE

1.1 Features

Ultra-low power consumption technology

- V_{DD} = single power supply voltage of 1.6 to 5.5 V
- HALT mode
- STOP mode
- SNOOZE mode

RL78 CPU core

- CISC architecture with 3-stage pipeline
- Minimum instruction execution time: Can be changed from high speed (0.03125 μ s: @ 32 MHz operation with high-speed on-chip oscillator) to ultra-low speed (30.5 μ s: @ 32.768 kHz operation with subsystem clock)
- Address space: 1 MB
- General-purpose registers: (8-bit register \times 8) \times 4 banks
- On-chip RAM: 2 to 32 KB

Code flash memory

- Code flash memory: 16 to 512 KB
- Block size: 1 KB
- Prohibition of block erase and rewriting (security function)
- On-chip debug function
- Self-programming (with boot swap function/flash shield window function)

Data flash memory

- Data flash memory: 4 KB to 8 KB
- Back ground operation (BGO): Instructions can be executed from the program memory while rewriting the data flash memory.
- Number of rewrites: 1,000,000 times (TYP.)
- Voltage of rewrites: V_{DD} = 1.8 to 5.5 V

High-speed on-chip oscillator

- Select from 32 MHz, 24 MHz, 16 MHz, 12 MHz, 8 MHz, 6 MHz, 4 MHz, 3 MHz, 2 MHz, and 1 MHz
- High accuracy: $\pm 1.0\%$ (V_{DD} = 1.8 to 5.5 V, T_A = -20 to +85°C)

Operating ambient temperature

- T_A = -40 to +85°C (A: Consumer applications, D: Industrial applications)
- T_A = -40 to +105°C (G: Industrial applications)

Power management and reset function

- On-chip power-on-reset (POR) circuit
- On-chip voltage detector (LVD) (Select interrupt and reset from 14 levels)

DMA (Direct Memory Access) controller

- 2/4 channels
- Number of clocks during transfer between 8/16-bit SFR and internal RAM: 2 clocks

Multiplier and divider/multiply-accumulator

- $16 \text{ bits} \times 16 \text{ bits} = 32 \text{ bits}$ (Unsigned or signed)
- $32 \text{ bits} \div 32 \text{ bits} = 32 \text{ bits}$ (Unsigned)
- $16 \text{ bits} \times 16 \text{ bits} + 32 \text{ bits} = 32 \text{ bits}$ (Unsigned or signed)

Serial interface

- Simplified SPI (CSI ^{Note 1}): 2 to 8 channels
- UART/UART (LIN-bus supported): 2 to 4 channels
- I²C/Simplified I²C communication: 3 to 10 channels

Timer

- 16-bit timer: 8 to 16 channels
- 12-bit interval timer: 1 channel
- Real-time clock: 1 channel (calendar for 99 years, alarm function, and clock correction function)
- Watchdog timer: 1 channel (operable with the dedicated low-speed on-chip oscillator)

A/D converter

- 8/10-bit resolution A/D converter ($V_{DD} = 1.6$ to 5.5 V)
- Analog input: 6 to 26 channels
- Internal reference voltage (1.45 V) and temperature sensor ^{Note 2}

I/O port

- I/O port: 16 to 120 (N-ch open drain I/O [withstand voltage of 6 V]: 0 to 4, N-ch open drain I/O [V_{DD} withstand voltage ^{Note 3}/ EV_{DD} withstand voltage ^{Note 4}]: 5 to 25)
- Can be set to N-ch open drain, TTL input buffer, and on-chip pull-up resistor
- Different potential interface: Can connect to a $1.8/2.5/3 \text{ V}$ device
- On-chip key interrupt function
- On-chip clock output/buzzer output controller

Others

- On-chip BCD (binary-coded decimal) correction circuit

Notes 1. Although the CSI function is generally called SPI, it is also called CSI in this product, so it is referred to as such in this manual.

2. Can be selected only in HS (high-speed main) mode

3. Products with 20 to 52 pins

4. Products with 64 to 128 pins

Remark The functions mounted depend on the product. See **1.6 Outline of Functions**.

O ROM, RAM capacities

Flash ROM	Data flash	RAM	RL78/G13					
			20 pins	24 pins	25 pins	30 pins	32 pins	36 pins
128 KB	8 KB	12 KB	–	–	–	R5F100AG	R5F100BG	R5F100CG
	–		–	–	R5F101AG	R5F101BG	R5F101CG	
96 KB	8 KB	8 KB	–	–	–	R5F100AF	R5F100BF	R5F100CF
	–		–	–	R5F101AF	R5F101BF	R5F101CF	
64 KB	4 KB	4 KB Note	R5F1006E	R5F1007E	R5F1008E	R5F100AE	R5F100BE	R5F100CE
	–		R5F1016E	R5F1017E	R5F1018E	R5F101AE	R5F101BE	R5F101CE
48 KB	4 KB	3 KB Note	R5F1006D	R5F1007D	R5F1008D	R5F100AD	R5F100BD	R5F100CD
	–		R5F1016D	R5F1017D	R5F1018D	R5F101AD	R5F101BD	R5F101CD
32 KB	4 KB	2 KB	R5F1006C	R5F1007C	R5F1008C	R5F100AC	R5F100BC	R5F100CC
	–		R5F1016C	R5F1017C	R5F1018C	R5F101AC	R5F101BC	R5F101CC
16 KB	4 KB	2 KB	R5F1006A	R5F1007A	R5F1008A	R5F100AA	R5F100BA	R5F100CA
	–		R5F1016A	R5F1017A	R5F1018A	R5F101AA	R5F101BA	R5F101CA

Flash ROM	Data flash	RAM	RL78/G13							
			40 pins	44 pins	48 pins	52 pins	64 pins	80 pins	100 pins	128 pins
512 KB	8 KB	32 KB Note	–	R5F100FL	R5F100GL	R5F100JL	R5F100LL	R5F100ML	R5F100PL	R5F100SL
	–		–	R5F101FL	R5F101GL	R5F101JL	R5F101LL	R5F101ML	R5F101PL	R5F101SL
384 KB	8 KB	24 KB	–	R5F100FK	R5F100GK	R5F100JK	R5F100LK	R5F100MK	R5F100PK	R5F100SK
	–		–	R5F101FK	R5F101GK	R5F101JK	R5F101LK	R5F101MK	R5F101PK	R5F101SK
256 KB	8 KB	20 KB Note	–	R5F100FJ	R5F100GJ	R5F100JJ	R5F100LJ	R5F100MJ	R5F100PJ	R5F100SJ
	–		–	R5F101FJ	R5F101GJ	R5F101JJ	R5F101LJ	R5F101MJ	R5F101PJ	R5F101SJ
192 KB	8 KB	16 KB	R5F100EH	R5F100FH	R5F100GH	R5F100JH	R5F100LH	R5F100MH	R5F100PH	R5F100SH
	–		R5F101EH	R5F101FH	R5F101GH	R5F101JH	R5F101LH	R5F101MH	R5F101PH	R5F101SH
128 KB	8 KB	12 KB	R5F100EG	R5F100FG	R5F100GG	R5F100JG	R5F100LG	R5F100MG	R5F100PG	–
	–		R5F101EG	R5F101FG	R5F101GG	R5F101JG	R5F101LG	R5F101MG	R5F101PG	–
96 KB	8 KB	8 KB	R5F100EF	R5F100FF	R5F100GF	R5F100JF	R5F100LF	R5F100MF	R5F100PF	–
	–		R5F101EF	R5F101FF	R5F101GF	R5F101JF	R5F101LF	R5F101MF	R5F101PF	–
64 KB	4 KB	4 KB Note	R5F100EE	R5F100FE	R5F100GE	R5F100JE	R5F100LE	–	–	–
	–		R5F101EE	R5F101FE	R5F101GE	R5F101JE	R5F101LE	–	–	–
48 KB	4 KB	3 KB Note	R5F100ED	R5F100FD	R5F100GD	R5F100JD	R5F100LD	–	–	–
	–		R5F101ED	R5F101FD	R5F101GD	R5F101JD	R5F101LD	–	–	–
32 KB	4 KB	2 KB	R5F100EC	R5F100FC	R5F100GC	R5F100JC	R5F100LC	–	–	–
	–		R5F101EC	R5F101FC	R5F101GC	R5F101JC	R5F101LC	–	–	–
16 KB	4 KB	2 KB	R5F100EA	R5F100FA	R5F100GA	–	–	–	–	–
	–		R5F101EA	R5F101FA	R5F101GA	–	–	–	–	–

Note The flash library uses RAM in self-programming and rewriting of the data flash memory. The target products and start address of the RAM areas used by the flash library are shown below.

- R5F100xD, R5F101xD (x = 6 to 8, A to C, E to G, J, L): Start address FF300H
- R5F100xE, R5F101xE (x = 6 to 8, A to C, E to G, J, L): Start address FEF00H
- R5F100xJ, R5F101xJ (x = F, G, J, L, M, P): Start address FAF00H
- R5F100xL, R5F101xL (x = F, G, J, L, M, P, S): Start address F7F00H

For the RAM areas used by the flash library, see **Self RAM list of Flash Self-Programming Library for RL78 Family (R20UT2944)**.

1.2 List of Part Numbers

Figure 1-1. Part Number, Memory Size, and Package of RL78/G13

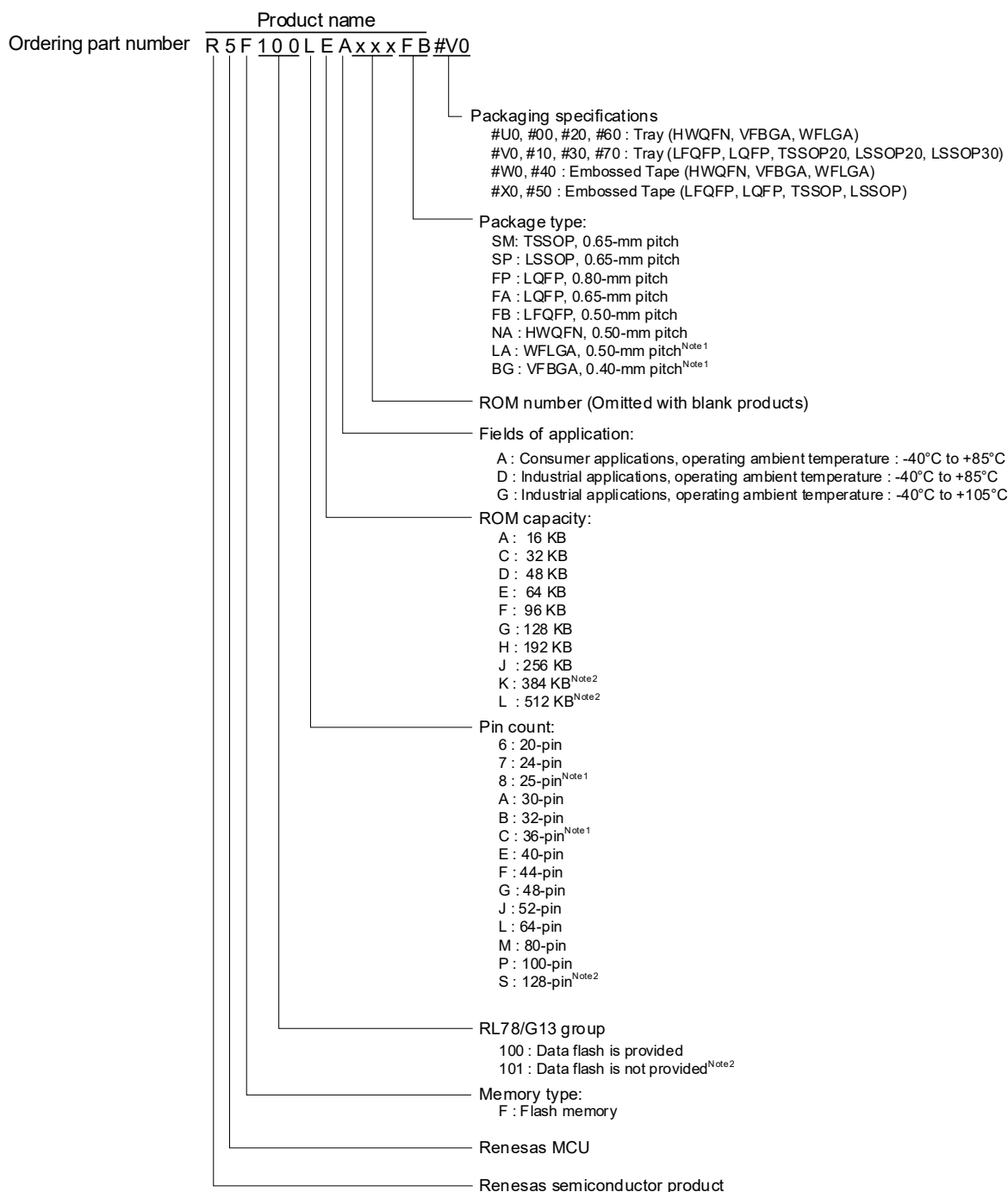

- Notes**
1. Products only for "A: Consumer applications (T_A = -40 to +85°C)", and "G: Industrial applications (T_A = -40 to +105°C)"
 2. Products only for "A: Consumer applications (T_A = -40 to +85°C)", and "D: Industrial applications (T_A = -40 to +85°C)"

Table 1-1. List of Ordering Part Numbers

(1/8)

Pin count	Package	Data flash	Fields of Application Note	Ordering Part Number		RENESAS Code
				Product Name	Packaging Specifications	
20 pins	20-pin plastic LSSOP (7.62 mm (300), 0.65-mm pitch)	Mounted	A	R5F1006AASP, R5F1006CASP, R5F1006DASP, R5F1006EASP	#V0, #10, #30, #X0, #50, #70	PLSP0020JC-A
			D	R5F1006ADSP, R5F1006CDSP, R5F1006DDSP, R5F1006EDSP		
			G	R5F1006AGSP, R5F1006CGSP, R5F1006DGSP, R5F1006EGSP		
		Not mounted	A	R5F1016AASP, R5F1016CASP, R5F1016DASP, R5F1016EASP	#V0, #10, #30, #X0, #50, #70	
	D		R5F1016ADSP, R5F1016CDSP, R5F1016DDSP, R5F1016EDSP			
	20-pin plastic TSSOP (4.4 x 6.5 mm, 0.65-mm pitch)	Mounted	A	R5F1006AASM, R5F1006CASM, R5F1006DASM, R5F1006EASM	#10, #30, #50, #70	PTSP0020JI-A
G			R5F1006AGSM, R5F1006CGSM, R5F1006DGSM, R5F1006EGSM			
Not mounted		A	R5F1016AASM, R5F1016CASM, R5F1016DASM, R5F1016EASM			
24 pins	24-pin plastic HWQFN (4 x 4 mm, 0.5-mm pitch)	Mounted	A	R5F1007AANA, R5F1007CANA, R5F1007DANA, R5F1007EANA	#U0, #W0	PWQN0024KE-A
				#00, #20, #40, #60	PWQN0024KF-A PWQN0024KH-A	
			D	R5F1007ADNA, R5F1007CDNA, R5F1007DDNA, R5F1007EDNA	#U0, #W0	PWQN0024KE-A
				G	R5F1007AGNA, R5F1007CGNA, R5F1007DGNA, R5F1007EGNA	#00, #20, #40, #60
		R5F1007AGNA, R5F1007CGNA, R5F1007DGNA, R5F1007EGNA				
		Not mounted	A	R5F1017AANA, R5F1017CANA, R5F1017DANA, R5F1017EANA	#U0, #W0	PWQN0024KE-A
				#00, #20, #40, #60	PWQN0024KF-A PWQN0024KH-A	
			D	R5F1017ADNA, R5F1017CDNA, R5F1017DDNA, R5F1017EDNA	#U0, #W0	PWQN0024KE-A
25 pins	25-pin plastic WFLGA (3 x 3 mm, 0.5-mm pitch)	Mounted	A	R5F1008AALA, R5F1008CALA, R5F1008DALA, R5F1008EALA	#U0, #W0	PWLG0025KA-A
			G	R5F1008AGLA, R5F1008CGLA, R5F1008DGLA, R5F1008EGLA		
		Not mounted	A	R5F1018AALA, R5F1018CALA, R5F1018DALA, R5F1018EALA	#U0, #W0	PWLG0025KA-A

Note For the fields of application, refer to **Figure 1-1 Part Number, Memory Size, and Package of RL78/G13**.

Caution The ordering part numbers represent the numbers at the time of publication. For the latest ordering part numbers, refer to the target product page of the Renesas Electronics website.

Table 1-1. List of Ordering Part Numbers

(2/8)

Pin count	Package	Data flash	Fields of Application <small>Note</small>	Ordering Part Number		RENESAS Code
				Product Name	Packaging Specifications	
30 pins	30-pin plastic LSSOP (7.62 mm (300), 0.65-mm pitch)	Mounted	A	R5F100AAASP, R5F100ACASP, R5F100ADASP, R5F100AEASP, R5F100AFASP, R5F100AGASP	#V0, #10, #30, #X0, #50, #70	PLSP0030JB-B
			D	R5F100AADSP, R5F100ACDSP, R5F100ADDSP, R5F100AEDSP, R5F100AFDSP, R5F100AGDSP		
			G	R5F100AAGSP, R5F100ACGSP, R5F100ADGSP, R5F100AEGSP, R5F100AFGSP, R5F100AGGSP		
		Not mounted	A	R5F101AAASP, R5F101ACASP, R5F101ADASP, R5F101AEASP, R5F101AFASP, R5F101AGASP	#V0, #10, #30, #X0, #50, #70	PLSP0030JB-B
D	R5F101AADSP, R5F101ACDSP, R5F101ADDSP, R5F101AEDSP, R5F101AFDSP, R5F101AGDSP					
32 pins	32-pin plastic HWQFN (5 × 5 mm, 0.5-mm pitch)	Mounted	A	R5F100BAANA, R5F100BCANA, R5F100BDANA, R5F100BEANA, R5F100BFANA, R5F100BGANA	#U0, #W0	PWQN0032KB-A
			D	R5F100BADNA, R5F100BCDNA, R5F100BDDNA, R5F100BEDNA, R5F100BFDNA, R5F100BGDNA	#U0, #W0	PWQN0032KB-A
				G		
			R5F100BAGNA, R5F100BCGNA, R5F100BDGNA, R5F100BEGNA, R5F100BFGNA, R5F100BGGNA		#00, #20, #40, #60	PWQN0032KE-A PWQN0032KG-A
		Not mounted	A	R5F101BAANA, R5F101BCANA, R5F101BDANA, R5F101BEANA, R5F101BFANA, R5F101BGANA	#U0, #W0	PWQN0032KB-A
			D	R5F101BADNA, R5F101BCDNA, R5F101BDDNA, R5F101BEDNA, R5F101BFDNA, R5F101BGDNA		
36 pins	36-pin plastic WFLGA (4 × 4 mm, 0.5-mm pitch)	Mounted	A	R5F100CAALA, R5F100CCALA, R5F100CDALA, R5F100CEALA, R5F100CFALA, R5F100CGALA	#U0, #W0	PWL G0036KA-A
			G	R5F100CAGLA, R5F100CCGLA, R5F100CDGLA, R5F100CEGLA, R5F100CFGLA, R5F100CGGLA		
		Not mounted	A	R5F101CAALA, R5F101CCALA, R5F101CDALA, R5F101CEALA, R5F101CFALA, R5F101CGALA	#U0, #W0	PWL G0036KA-A
			D	R5F101BADNA, R5F101BCDNA, R5F101BDDNA, R5F101BEDNA, R5F101BFDNA, R5F101BGDNA		
40 pins	40-pin plastic HWQFN (6 × 6 mm, 0.5-mm pitch)	Mounted	A	R5F100EAANA, R5F100ECANA, R5F100EDANA, R5F100EEANA, R5F100EFANA, R5F100EGANA, R5F100EHANA	#U0, #W0	PWQN0040KC-A
			D	R5F100EADNA, R5F100ECDNA, R5F100EDDNA, R5F100EEDNA, R5F100EFDNA, R5F100EGDNA, R5F100EHDNA	#U0, #W0	PWQN0040KC-A
				G		
			R5F100EAGNA, R5F100ECGNA, R5F100EDGNA, R5F100EEGNA, R5F100EFGNA, R5F100EGGNA, R5F100EHGNA		#00, #20, #40, #60	PWQN0040KD-A PWQN0040KE-A
		Not mounted	A	R5F101EAANA, R5F101ECANA, R5F101EDANA, R5F101EEANA, R5F101EFANA, R5F101EGANA, R5F101EHANA	#U0, #W0	PWQN0040KC-A
			D	R5F101EADNA, R5F101ECDNA, R5F101EDDNA, R5F101EEDNA, R5F101EFDNA, R5F101EGDNA, R5F101EHDNA		

Note For the fields of application, refer to **Figure 1-1 Part Number, Memory Size, and Package of RL78/G13.**

Caution The ordering part numbers represent the numbers at the time of publication. For the latest ordering part numbers, refer to the target product page of the Renesas Electronics website.

Table 1-1. List of Ordering Part Numbers

(3/8)

Pin count	Package	Data flash	Fields of Application Note	Ordering Part Number		RENESAS Code	
				Product Name	Packaging Specifications		
<R>	44-pin plastic LQFP (10 × 10 mm, 0.8-mm pitch)	Mounted	A	R5F100FAAFP, R5F100FCAFP, R5F100FDAFP, R5F100FEAFP, R5F100FFAFP, R5F100FGAFP, R5F100FHAFP, R5F100FJAFP, R5F100FKAFP, R5F100FLAFP	#V0, #X0	PLQP0044GC-A	
					#10, #50, #70	PLQP0044GC-A PLQP0044GC-D PLQP0044GE-A PLQP0044GF-A	
					#30	PLQP0044GC-A PLQP0044GC-D	
			D		#V0, #X0	PLQP0044GC-A	
					#10, #50, #70	PLQP0044GC-A PLQP0044GC-D PLQP0044GF-A	
					#30	PLQP0044GC-A PLQP0044GC-D	
		<R>			R5F100FKDFP, R5F100FLDFP	#V0, #X0	PLQP0044GC-A
						#10, #50, #70	PLQP0044GC-A PLQP0044GC-D PLQP0044GE-A PLQP0044GF-A
						#30	PLQP0044GC-A PLQP0044GC-D
					G	#V0, #X0	PLQP0044GC-A
						#10, #50, #70	PLQP0044GC-A PLQP0044GC-D PLQP0044GE-A PLQP0044GF-A
						#30	PLQP0044GC-A PLQP0044GC-D
<R>		Not mounted	A	R5F101FAAFP, R5F101FCAFP, R5F101FDAFP, R5F101FEAFP, R5F101FFAFP, R5F101FGAFP, R5F101FHAFP, R5F101FJAFP, R5F101FKAFP, R5F101FLAFP	#V0, #X0	PLQP0044GC-A	
					#10, #50, #70	PLQP0044GC-A PLQP0044GC-D PLQP0044GE-A PLQP0044GF-A	
					#30	PLQP0044GC-A PLQP0044GC-D	
			D		#V0, #X0	PLQP0044GC-A	
					#10, #50, #70	PLQP0044GC-A PLQP0044GC-D PLQP0044GF-A	
					#30	PLQP0044GC-A PLQP0044GC-D	
<R>			R5F101FKDFP, R5F101FLDFP	#V0, #X0	PLQP0044GC-A		
				#10, #50, #70	PLQP0044GC-A PLQP0044GC-D PLQP0044GE-A PLQP0044GF-A		
				#30	PLQP0044GC-A PLQP0044GC-D		

Note For the fields of application, refer to **Figure 1-1 Part Number, Memory Size, and Package of RL78/G13**.

Caution The ordering part numbers represent the numbers at the time of publication. For the latest ordering part numbers, refer to the target product page of the Renesas Electronics website.

Table 1-1. List of Ordering Part Numbers

(4/8)

Pin count	Package	Data flash	Fields of Application Note	Ordering Part Number		RENESAS Code
				Product Name	Packaging Specifications	
48 pins	48-pin plastic LFQFP (7 × 7 mm, 0.5-mm pitch)	Mounted	A	R5F100GAAFB, R5F100GCAFB, R5F100GDADF, R5F100GEAFB, R5F100GFAFB, R5F100GGAFB, R5F100GHAFB, R5F100GJAFB, R5F100GKAFB, R5F100GLAFB	#V0, #X0	PLQP0048KF-A
					#10, #50, #70	PLQP0048KB-B PLQP0048KL-A
					#30	PLQP0048KB-B
			D	R5F100GADFB, R5F100GCDFB, R5F100GDDFB, R5F100GEDFB, R5F100GFDFB, R5F100GGDFB, R5F100GHDFB, R5F100GJDFB	#V0, #X0	PLQP0048KF-A
					#10, #30, #50, #70	PLQP0048KB-B PLQP0048KL-A
					#30	PLQP0048KB-B
				R5F100GKDFB, R5F100GLDFB	#V0, #X0	PLQP0048KF-A
					#10, #50, #70	PLQP0048KB-B PLQP0048KL-A
					#30	PLQP0048KB-B
		G	R5F100GAGFB, R5F100GCGFB, R5F100GDGFB, R5F100GEGFB, R5F100GFGFB, R5F100GGGFB, R5F100GHGFB, R5F100GJGFB	#V0, #X0	PLQP0048KF-A	
				#10, #50, #70	PLQP0048KB-B PLQP0048KL-A	
				#30	PLQP0048KB-B	
		Not mounted	A	R5F101GAAFB, R5F101GCAFB, R5F101GDADF, R5F101GEAFB, R5F101GFAFB, R5F101GGAFB, R5F101GHAFB, R5F101GJAFB, R5F101GKAFB, R5F101GLAFB	#V0, #X0	PLQP0048KF-A
					#10, #50, #70	PLQP0048KB-B PLQP0048KL-A
					#30	PLQP0048KB-B
			D	R5F101GADFB, R5F101GCDFB, R5F101GDDFB, R5F101GEDFB, R5F101GFDFB, R5F101GGDFB, R5F101GHDFB, R5F101GJDFB	#V0, #X0	PLQP0048KF-A
					#10, #30, #50, #70	PLQP0048KB-B PLQP0048KL-A
					#30	PLQP0048KB-B
R5F101GKDFB, R5F101GLDFB	#V0, #X0			PLQP0048KF-A		
	#10, #50, #70			PLQP0048KB-B PLQP0048KL-A		
	#30			PLQP0048KB-B		
48-pin plastic HWQFN (7 × 7 mm, 0.5-mm pitch)	Mounted	A	R5F100GAANA, R5F100GCANA, R5F100GDANA, R5F100GEANA, R5F100GFANA, R5F100GGANA, R5F100GHANA, R5F100GJANA, R5F100GKANA, R5F100GLANA	#U0, #W0	PWQN0048KB-A	
				#00, #20, #40, #60	PWQN0048KE-A PWQN0048KG-A	
				#60	PWQN0048KB-A	
			D	R5F100GADNA, R5F100GCDNA, R5F100GDDNA, R5F100GEDNA, R5F100GFDNA, R5F100GGDNA, R5F100GHDNA, R5F100GJDNA, R5F100GKDNA, R5F100GLDNA	#U0, #W0	PWQN0048KB-A
					#00, #20, #40, #60	PWQN0048KE-A PWQN0048KG-A
					#60	PWQN0048KB-A
				R5F100GKDNA, R5F100GLDNA	#U0, #W0	PWQN0048KB-A
					#00, #20, #40, #60	PWQN0048KE-A PWQN0048KG-A
					#60	PWQN0048KB-A
		Not mounted	A	R5F101GAANA, R5F101GCANA, R5F101GDANA, R5F101GEANA, R5F101GFANA, R5F101GGANA, R5F101GHANA, R5F101GJANA, R5F101GKANA, R5F101GLANA	#U0, #W0	PWQN0048KB-A
					#00, #20, #40, #60	PWQN0048KE-A PWQN0048KG-A
					#60	PWQN0048KB-A
			D	R5F101GADNA, R5F101GCDNA, R5F101GDDNA, R5F101GEDNA, R5F101GFDNA, R5F101GGDNA, R5F101GHDNA, R5F101GJDNA, R5F101GKDNA, R5F101GLDNA	#U0, #W0	PWQN0048KB-A
					#00, #20, #40, #60	PWQN0048KE-A PWQN0048KG-A
					#60	PWQN0048KB-A
				R5F101GKDNA, R5F101GLDNA	#U0, #W0	PWQN0048KB-A
					#00, #20, #40, #60	PWQN0048KE-A PWQN0048KG-A
					#60	PWQN0048KB-A

Note For the fields of application, refer to Figure 1-1 Part Number, Memory Size, and Package of RL78/G13.

Caution The ordering part numbers represent the numbers at the time of publication. For the latest ordering part numbers, refer to the target product page of the Renesas Electronics website.

Table 1-1. List of Ordering Part Numbers

(5/8)

Pin count	Package	Data flash	Fields of Application <small>Note</small>	Ordering Part Number		RENESAS Code
				Product Name	Packaging Specifications	
52 pins	52-pin plastic LQFP (10 × 10 mm, 0.65-mm pitch)	Mounted	A	R5F100JCAFA, R5F100JDAFA, R5F100JEAFA, R5F100JFAFA, R5F100JGAFA, R5F100JHAFA, R5F100JJAFA, R5F100JKAFA, R5F100JLAFA	#V0, #X0 #10, #30, #50, #70	PLQP0052JA-A PLQP0052JA-A PLQP0052JD-B
			D	R5F100JCDFA, R5F100JDDFA, R5F100JEDFA, R5F100JFDFA, R5F100JGDF, R5F100JHDF, R5F100JJDF, R5F100JKDF, R5F100JLDF	#V0, #10, #30, #X0, #50, #70	PLQP0052JA-A
			G	R5F100JCGFA, R5F100JGDF, R5F100JEGFA, R5F100JFGFA, R5F100JGGFA, R5F100JHGFA, R5F100JJGFA	#V0, #X0 #10, #30, #50, #70	PLQP0052JA-A PLQP0052JA-A PLQP0052JD-B
		Not mounted	A	R5F101JCAFA, R5F101JDAFA, R5F101JEAFA, R5F101JFAFA, R5F101JGAFA, R5F101JHAFA, R5F101JJAFA, R5F101JKAFA, R5F101JLAFA	#V0, #X0 #10, #30, #50, #70	PLQP0052JA-A PLQP0052JA-A PLQP0052JD-B
			D	R5F101JCDFA, R5F101JDDFA, R5F101JEDFA, R5F101JFDFA, R5F101JGDF, R5F101JHDF, R5F101JJDF, R5F101JKDF, R5F101JLDF	#V0, #10, #30, #X0, #50, #70	PLQP0052JA-A
			G	R5F101JCGFA, R5F101JGDF, R5F101JEGFA, R5F101JFGFA, R5F101JGGFA, R5F101JHGFA, R5F101JJGFA	#V0, #X0 #10, #30, #50, #70	PLQP0052JA-A PLQP0052JA-A PLQP0052JD-B

Note For the fields of application, refer to **Figure 1-1 Part Number, Memory Size, and Package of RL78/G13**.

Caution The ordering part numbers represent the numbers at the time of publication. For the latest ordering part numbers, refer to the target product page of the Renesas Electronics website.

Table 1-1. List of Ordering Part Numbers

(6/8)

Pin count	Package	Data flash	Fields of Application Note	Ordering Part Number		RENESAS Code
				Product Name	Packaging Specifications	
64 pins	64-pin plastic LQFP (12 × 12 mm, 0.65-mm pitch)	Mounted	A	R5F100LCAFA, R5F100LDAFA, R5F100LEAFA, R5F100LFafa, R5F100LGafa, R5F100LHafa, R5F100LJafa, R5F100LKafa, R5F100LLafa	#V0, #X0 #10, #30, #50, #70	PLQP0064JA-A PLQP0064JA-A PLQP0064JB-A
			D	R5F100LCDFA, R5F100LDDFA, R5F100LEDFA, R5F100LFDFA, R5F100LGdFA, R5F100LHDFA, R5F100LJDFA, R5F100LKdFA, R5F100LLDFA	#V0, #10, #30, #X0, #50, #70	PLQP0064JA-A
			G	R5F100LCGFA, R5F100LDGFA, R5F100LEGFA, R5F100LFGFA, R5F100LGGFA, R5F100LHGFA, R5F100LJGFA	#V0, #X0 #10, #30, #50, #70	PLQP0064JA-A PLQP0064JA-A PLQP0064JB-A
	64-pin plastic LQFP (12 × 12 mm, 0.65-mm pitch)	Not mounted	A	R5F101LCAFA, R5F101LDAFA, R5F101LEAFA, R5F101LFafa, R5F101LGafa, R5F101LHafa, R5F101LJafa, R5F101LKafa, R5F101LLafa	#V0, #X0 #10, #30, #50, #70	PLQP0064JA-A PLQP0064JA-A PLQP0064JB-A
			D	R5F101LCDFA, R5F101LDDFA, R5F101LEDFA, R5F101LFDFA, R5F101LGdFA, R5F101LHDFA, R5F101LJDFA, R5F101LKdFA, R5F101LLDFA	#V0, #10, #30, #X0, #50, #70	PLQP0064JA-A
	64-pin plastic LFQFP (10 × 10 mm, 0.5-mm pitch)	Mounted	A	R5F100LCAFB, R5F100LDAFB, R5F100LEAFB, R5F100LFAFB, R5F100LGAFB, R5F100LHAFB, R5F100LJAFB, R5F100LKA FB, R5F100LLAFB	#V0, #X0	PLQP0064KF-A
#10, #50, #70					PLQP0064KB-C PLQP0064KL-A	
#30					PLQP0064KB-C	
D			R5F100LCDFB, R5F100LDDFB, R5F100LEDFB, R5F100LFD FB, R5F100LGDFB, R5F100LHDFB, R5F100LJDFB R5F100LKDFB, R5F100LLDFB	#V0, #X0	PLQP0064KF-A	
				#10, #30, #50, #70	PLQP0064KB-C	
				#V0, #X0 #10, #50, #70	PLQP0064KF-A PLQP0064KB-C PLQP0064KL-A	
G		R5F100LCGFB, R5F100LDGFB, R5F100LEGFB, R5F100LFGFB, R5F100LGGFB, R5F100LHGFB, R5F100LJGFB	#V0, #X0	PLQP0064KF-A		
			#10, #50, #70	PLQP0064KB-C PLQP0064KL-A		
			#30	PLQP0064KB-C		
Not mounted		A	R5F101LCAFB, R5F101LDAFB, R5F101LEAFB, R5F101LFAFB, R5F101LGAFB, R5F101LHAFB, R5F101LJAFB, R5F101LKA FB, R5F101LLAFB	#V0, #X0	PLQP0064KF-A	
				#10, #50, #70	PLQP0064KB-C PLQP0064KL-A	
				#30	PLQP0064KB-C	
	D	R5F101LCDFB, R5F101LDDFB, R5F101LEDFB, R5F101LFD FB, R5F101LGDFB, R5F101LHDFB, R5F101LJDFB R5F101LKDFB, R5F101LLDFB	#V0, #X0	PLQP0064KF-A		
			#10, #30, #50, #70	PLQP0064KB-C		
			#V0, #X0 #10, #50, #70	PLQP0064KF-A PLQP0064KB-C PLQP0064KL-A		
G	R5F101LCGFB, R5F101LDGFB, R5F101LEGFB, R5F101LFGFB, R5F101LGGFB, R5F101LHGFB, R5F101LJGFB	#V0, #X0	PLQP0064KF-A			
		#10, #50, #70	PLQP0064KB-C PLQP0064KL-A			
		#30	PLQP0064KB-C			
64-pin plastic VFBGA (4 × 4 mm, 0.4-mm pitch)	Mounted	A	R5F100LCABG, R5F100LDABG, R5F100LEABG, R5F100LFABG, R5F100LGABG, R5F100LHABG, R5F100LJABG	#U0, #W0	PVBG0064LA-A	
		G	R5F100LCGBG, R5F100LDGBG, R5F100LEGBG, R5F100LFGBG, R5F100LGBBG, R5F100LHGBG, R5F100LJGBG			
	Not mounted	A	R5F101LCABG, R5F101LDABG, R5F101LEABG, R5F101LFABG, R5F101LGABG, R5F101LHABG, R5F101LJABG	#U0, #W0	PVBG0064LA-A	

Note For the fields of application, refer to Figure 1-1 Part Number, Memory Size, and Package of RL78/G13.

Caution The ordering part numbers represent the numbers at the time of publication. For the latest ordering part numbers, refer to the target product page of the Renesas Electronics website.

Table 1-1. List of Ordering Part Numbers

(7/8)

Pin count	Package	Data flash	Fields of Application Note	Ordering Part Number		RENESAS Code	
				Product Name	Packaging Specifications		
80 pins	80-pin plastic LQFP (14 × 14 mm, 0.65-mm pitch)	Mounted	A	R5F100MFAFA, R5F100MGafa, R5F100MHafa, R5F100MJafa, R5F100MKafa, R5F100MLafa	#V0, #10, #30, #X0, #50, #70	PLQP0080JB-E	
			D	R5F100MFDFA, R5F100MGdFA, R5F100MHdFA, R5F100MJdFA, R5F100MKdFA, R5F100MLdFA			
			G	R5F100MFGFA, R5F100MGgFA, R5F100MHgFA, R5F100MJGFA			
		Not mounted	A	R5F101MFAFA, R5F101MGafa, R5F101MHafa, R5F101MJafa, R5F101MKafa, R5F101MLafa	#V0, #10, #30, #X0, #50, #70		
	D		R5F101MFDFA, R5F101MGdFA, R5F101MHdFA, R5F101MJdFA, R5F101MKdFA, R5F101MLdFA				
	<R>	80-pin plastic LFQFP (12 × 12 mm, 0.5-mm pitch)	Mounted	A	R5F100MFAFB, R5F100MGafB, R5F100MHafB, R5F100MJafB, R5F100MKafB, R5F100MLafB	#V0, #X0	PLQP0080KE-A
						#10, #50, #70	PLQP0080KB-B PLQP0080KE-A PLQP0080KJ-A
						#30	PLQP0080KB-B
D				R5F100MFDfB, R5F100MGdfB, R5F100MHdfB, R5F100MJdfB	#V0, #X0	PLQP0080KE-A	
					#10, #50, #70	PLQP0080KB-B PLQP0080KE-A	
					#30	PLQP0080KB-B	
G			R5F100MFGfB, R5F100MGgfB, R5F100MHgfB, R5F100MJGfB	#V0, #X0	PLQP0080KE-A		
				#10, #50, #70	PLQP0080KB-B PLQP0080KE-A PLQP0080KJ-A		
				#30	PLQP0080KB-B		
Not mounted			A	R5F101MFAfB, R5F101MGafB, R5F101MHafB, R5F101MJafB, R5F101MKafB, R5F101MLafB	#V0, #X0	PLQP0080KE-A	
					#10, #50, #70	PLQP0080KB-B PLQP0080KE-A PLQP0080KJ-A	
					#30	PLQP0080KB-B	
	D	R5F101MFDfB, R5F101MGdfB, R5F101MHdfB, R5F101MJdfB	#V0, #X0	PLQP0080KE-A			
			#10, #50, #70	PLQP0080KB-B PLQP0080KE-A			
			#30	PLQP0080KB-B			
G	R5F101MFGfB, R5F101MGgfB, R5F101MHgfB, R5F101MJGfB	#V0, #X0	PLQP0080KE-A				
		#10, #50, #70	PLQP0080KB-B PLQP0080KE-A PLQP0080KJ-A				
		#30	PLQP0080KB-B				

Note For the fields of application, refer to Figure 1-1 Part Number, Memory Size, and Package of RL78/G13.

Caution The ordering part numbers represent the numbers at the time of publication. For the latest ordering part numbers, refer to the target product page of the Renesas Electronics website.

Table 1-1. List of Ordering Part Numbers

(8/8)

Pin count	Package	Data flash	Fields of Application Note	Ordering Part Number		RENESAS Code
				Product Name	Packaging Specifications	
100 pins	100-pin plastic LFQFP (14 × 14 mm, 0.5-mm pitch)	Mounted	A	R5F100PFAFB, R5F100PGAFA, R5F100PHAFA, R5F100PJAFB, R5F100PKAFB, R5F100PLAFB	#V0, #X0	PLQP0100KE-A
					#10, #50, #70	PLQP0100KB-B PLQP0100KP-A
					#30	PLQP0100KB-B
			D	R5F100PFDFB, R5F100PGDFB, R5F100PHDFB, R5F100PJDFB	#V0, #X0	PLQP0100KE-A
					#10, #30, #50, #70	PLQP0100KB-B
					#V0, #X0	PLQP0100KE-A
	G	R5F100PFGFB, R5F100PGGFB, R5F100PHGFB, R5F100PJGFB	#V0, #X0	PLQP0100KE-A		
			#10, #50, #70	PLQP0100KB-B PLQP0100KP-A		
			#30	PLQP0100KB-B		
	Not mounted	A	R5F101PFAFB, R5F101PGAFA, R5F101PHAFA, R5F101PJAFB, R5F101PKAFB, R5F101PLAFB	#V0, #X0	PLQP0100KE-A	
				#10, #50, #70	PLQP0100KB-B PLQP0100KP-A	
				#30	PLQP0100KB-B	
D		R5F101PFDFB, R5F101PGDFB, R5F101PHDFB, R5F101PJDFB	#V0, #X0	PLQP0100KE-A		
			#10, #30, #50, #70	PLQP0100KB-B		
			#V0, #X0	PLQP0100KE-A		
G	R5F101PFGFB, R5F101PGGFB, R5F101PHGFB, R5F101PJGFB	#V0, #X0	PLQP0100KE-A			
		#10, #50, #70	PLQP0100KB-B PLQP0100KP-A			
		#30	PLQP0100KB-B			
100-pin plastic LQFP (14 × 20 mm, 0.65-mm pitch)	Mounted	A	R5F100PFAFA, R5F100PGAFA, R5F100PHAFA, R5F100PJAFB, R5F100PKAFA, R5F100PLAFA	#V0, #10, #30, #X0, #50, #70	PLQP0100JC-A	
				D		R5F100PFDFB, R5F100PGDFB, R5F100PHDFB, R5F100PJDFB, R5F100PKDFB, R5F100PLDFB
	Not mounted	A	R5F101PFAFA, R5F101PGAFA, R5F101PHAFA, R5F101PJAFB, R5F101PKAFA, R5F101PLAFA	#V0, #10, #30, #X0, #50, #70	PLQP0100JC-A	
				D		R5F101PFDFB, R5F101PGDFB, R5F101PHDFB, R5F101PJDFB, R5F101PKDFB, R5F101PLDFB
128 pins	128-pin plastic LFQFP (14 × 20 mm, 0.5-mm pitch)	Mounted	A	R5F100SHAFA, R5F100SJAFA, R5F100SKAFA, R5F100SLAFA	#V0, #10, #30, #X0, #50, #70	PLQP0128KD-A
			D	R5F100SHDFB, R5F100SJDFB, R5F100SKDFB, R5F100SLDFB		
		Not mounted	A	R5F101SHAFA, R5F101SJAFA, R5F101SKAFA, R5F101SLAFA	#V0, #10, #30, #X0, #50, #70	PLQP0128KD-A
			D	R5F101SHDFB, R5F101SJDFB, R5F101SKDFB, R5F101SLDFB		

Note For the fields of application, refer to Figure 1-1 Part Number, Memory Size, and Package of RL78/G13.

Caution The ordering part numbers represent the numbers at the time of publication. For the latest ordering part numbers, refer to the target product page of the Renesas Electronics website.

1.3 Pin Configuration (Top View)

1.3.1 20-pin products

- 20-pin plastic LSSOP (7.62 mm (300), 0.65-mm pitch)
- 20-pin plastic TSSOP (4.4 × 6.5 mm, 0.65-mm pitch)

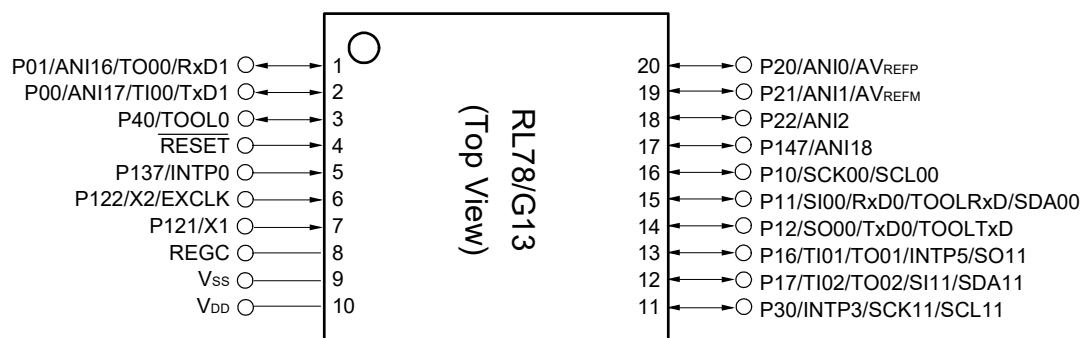

Caution Connect the REGC pin to V_{SS} via a capacitor (0.47 to 1 μF).

Remark For pin identification, see 1.4 Pin Identification.

1.3.2 24-pin products

- 24-pin plastic HWQFN (4 × 4 mm, 0.5-mm pitch)

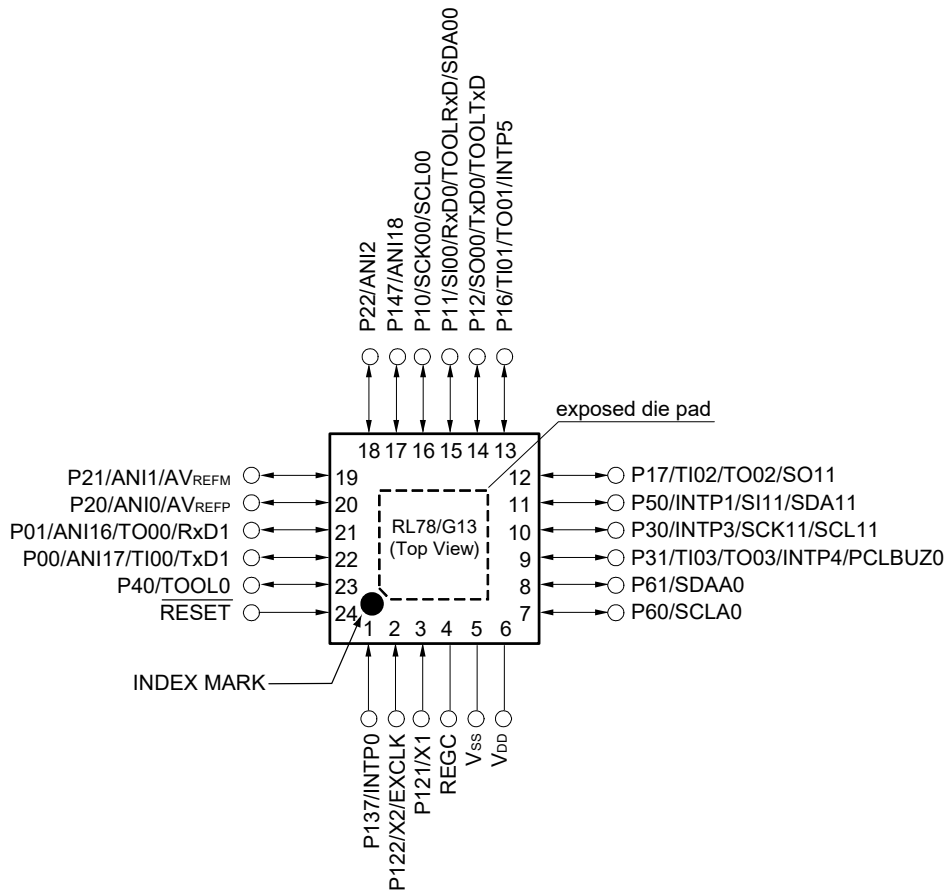

Caution Connect the REGC pin to V_{ss} via a capacitor (0.47 to 1 μF).

Remarks 1. For pin identification, see 1.4 Pin Identification.

2. It is recommended to connect an exposed die pad to V_{ss}.

1.3.3 25-pin products

- 25-pin plastic WFLGA (3 × 3 mm, 0.50-mm pitch)

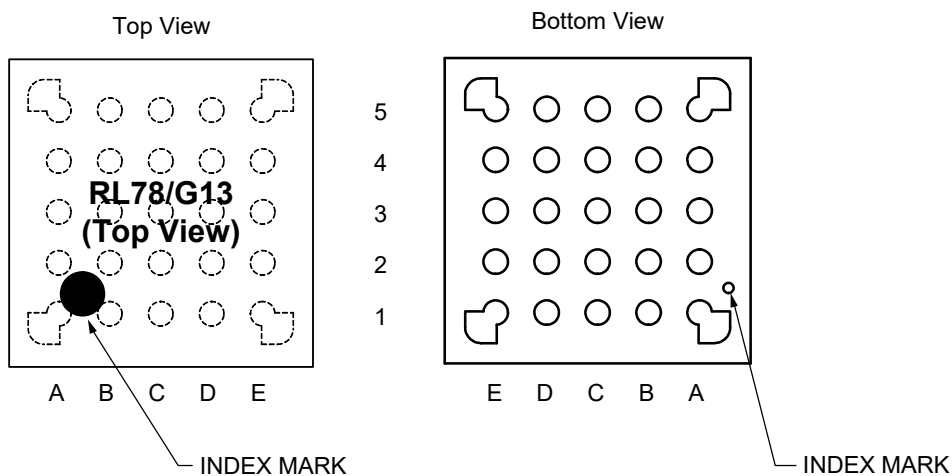

	A	B	C	D	E	
5	P40/TOOL0	RESET	P01/ANI16/ TO00/RxD1	P22/ANI2	P147/ANI18	5
4	P122/X2/ EXCLK	P137/INTP0	P00/ANI17/ TI00/TxD1	P21/ANI1/ AVREFM	P10/SCK00/ SCL00	4
3	P121/X1	V _{DD}	P20/ANI0/ AVREFP	P12/SO00/ TxD0/ TOOLTxD	P11/SI00/ RxD0/ TOOLRxD/ SDA00	3
2	REGC	V _{SS}	P30/INTP3/ SCK11/SCL11	P17/TI02/ TO02/SO11	P50/INTP1/ SI11/SDA11	2
1	P60/SCLA0	P61/SDAA0	P31/TI03/ TO03/INTP4/ PCLBUZ0	P16/TI01/ TO01/INTP5	P130	1
	A	B	C	D	E	

Caution Connect the REGC pin to V_{SS} via a capacitor (0.47 to 1 μF).

Remark For pin identification, see 1.4 Pin Identification.

1.3.4 30-pin products

- 30-pin plastic LSSOP (7.62 mm (300), 0.65-mm pitch)

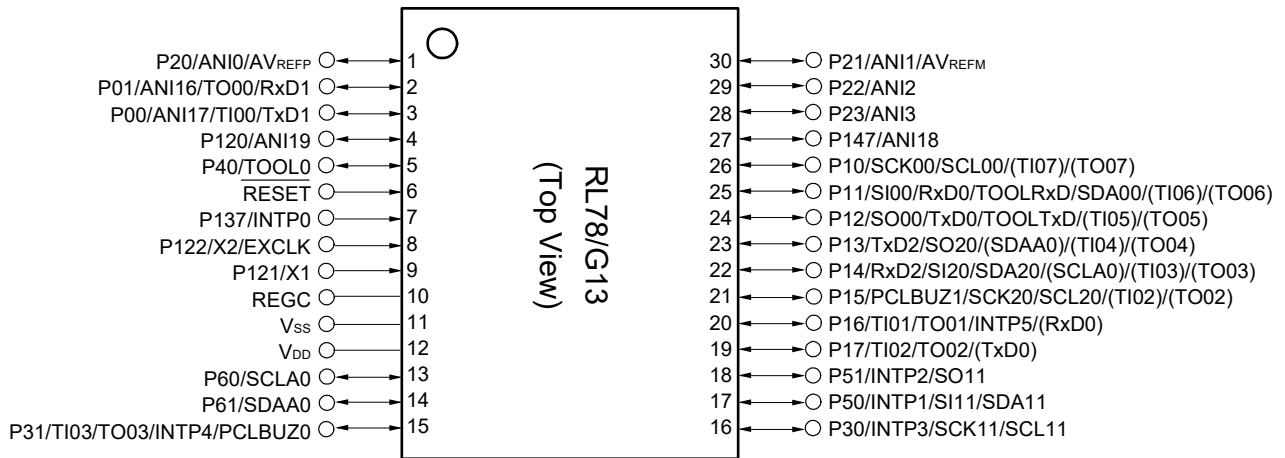

Caution Connect the REGC pin to V_{SS} via a capacitor (0.47 to 1 μF).

Remarks 1. For pin identification, see 1.4 Pin Identification.

2. Functions in parentheses in the above figure can be assigned via settings in the peripheral I/O redirection register (PIOR). Refer to **Figure 4-8 Format of Peripheral I/O Redirection Register (PIOR)**.

1.3.5 32-pin products

- 32-pin plastic HWQFN (5 × 5 mm, 0.5-mm pitch)

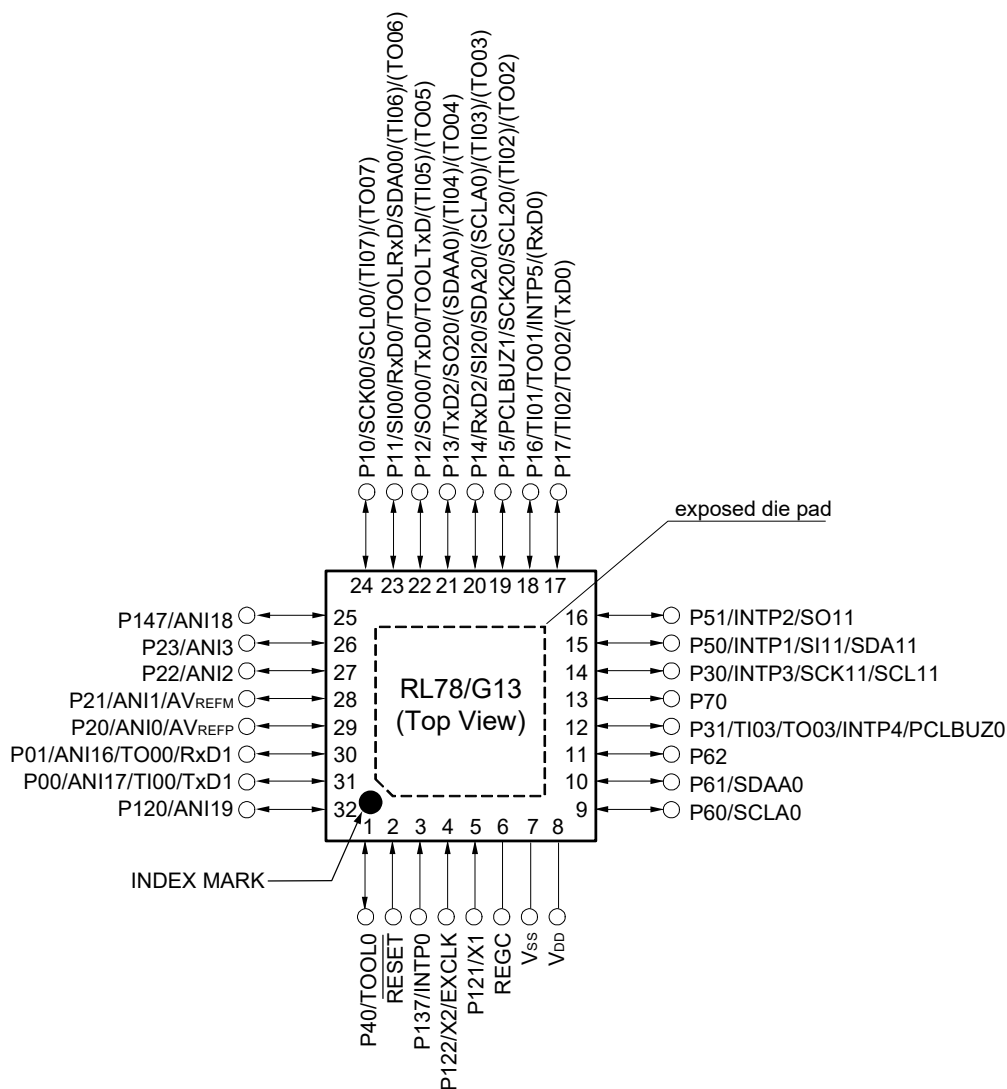

Caution Connect the REGC pin to Vss via a capacitor (0.47 to 1 μF).

Remarks 1. For pin identification, see 1.4 Pin Identification.

2. Functions in parentheses in the above figure can be assigned via settings in the peripheral I/O redirection register (PIOR). Refer to **Figure 4-8 Format of Peripheral I/O Redirection Register (PIOR)**.
3. It is recommended to connect an exposed die pad to Vss.

1.3.6 36-pin products

- 36-pin plastic WFLGA (4 × 4 mm, 0.5-mm pitch)

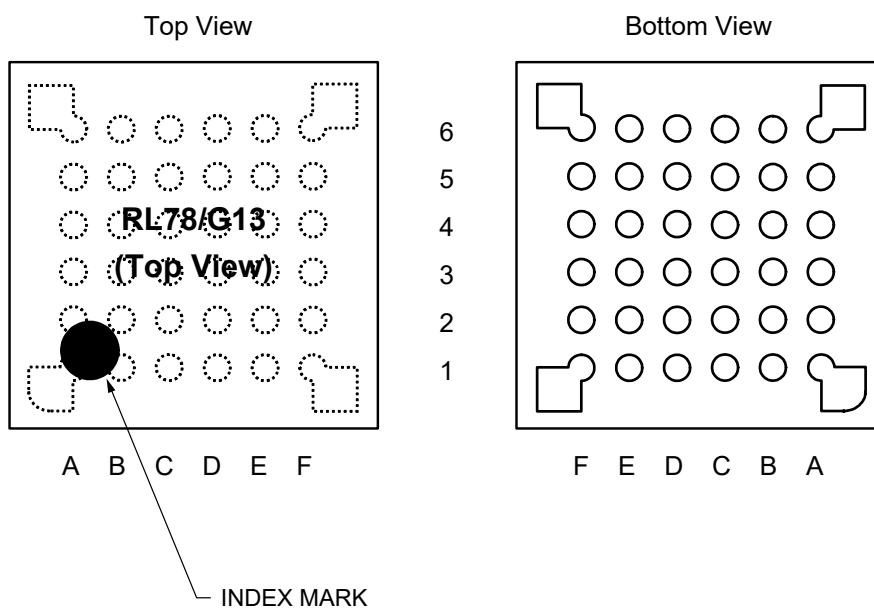

	A	B	C	D	E	F	
6	P60/SCLA0	V _{DD}	P121/X1	P122/X2/EXCLK	P137/INTP0	P40/TOOL0	6
5	P62	P61/SDAA0	V _{SS}	REGC	RESET	P120/ANI19	5
4	P72/SO21	P71/SI21/ SDA21	P14/RxD2/SI20/ SDA20/(SCLA0) /(TI03)/(TO03)	P31/TI03/TO03/ INTP4/ PCLBUZ0	P00/TI00/TxD1	P01/TO00/RxD1	4
3	P50/INTP1/ SI11/SDA11	P70/SCK21/ SCL21	P15/PCLBUZ1/ SCK20/SCL20/ (TI02)/(TO02)	P22/ANI2	P20/ANI0/ AV _{REFP}	P21/ANI1/ AV _{REFM}	3
2	P30/INTP3/ SCK11/SCL11	P16/TI01/TO01/ INTP5/(RxD0)	P12/SO00/ TxD0/TOOLTxD /(TI05)/(TO05)	P11/SI00/RxD0/ TOOLRxD/ SDA00/(TI06)/ (TO06)	P24/ANI4	P23/ANI3	2
1	P51/INTP2/ SO11	P17/TI02/TO02/ (TxD0)	P13/TxD2/ SO20/(SDAA0)/ (TI04)/(TO04)	P10/SCK00/ SCL00/(TI07)/ (TO07)	P147/ANI18	P25/ANI5	1
	A	B	C	D	E	F	

Caution Connect the REGC pin to V_{SS} via a capacitor (0.47 to 1 μF).

- Remarks 1.** For pin identification, see 1.4 Pin Identification.
- 2.** Functions in parentheses in the above figure can be assigned via settings in the peripheral I/O redirection register (PIOR). Refer to **Figure 4-8 Format of Peripheral I/O Redirection Register (PIOR)**.

1.3.7 40-pin products

- 40-pin plastic HWQFN (6 × 6 mm, 0.5-mm pitch)

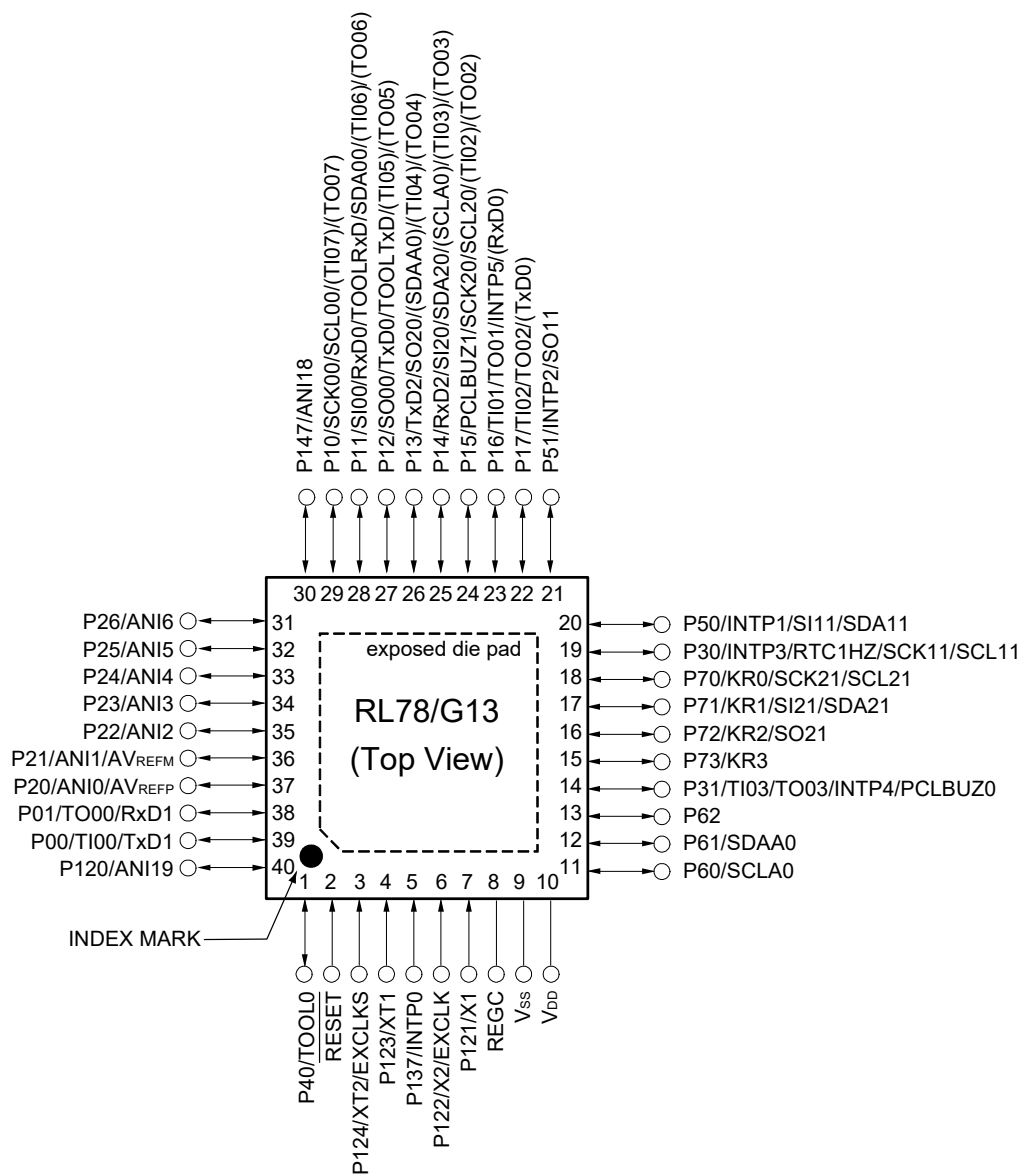

Caution Connect the REGC pin to Vss via a capacitor (0.47 to 1 μF).

- Remarks 1.** For pin identification, see 1.4 Pin Identification.
- Functions in parentheses in the above figure can be assigned via settings in the peripheral I/O redirection register (PIOR). Refer to **Figure 4-8 Format of Peripheral I/O Redirection Register (PIOR)**.
 - It is recommended to connect an exposed die pad to Vss.

1.3.8 44-pin products

- 44-pin plastic LQFP (10 × 10 mm, 0.8-mm pitch)

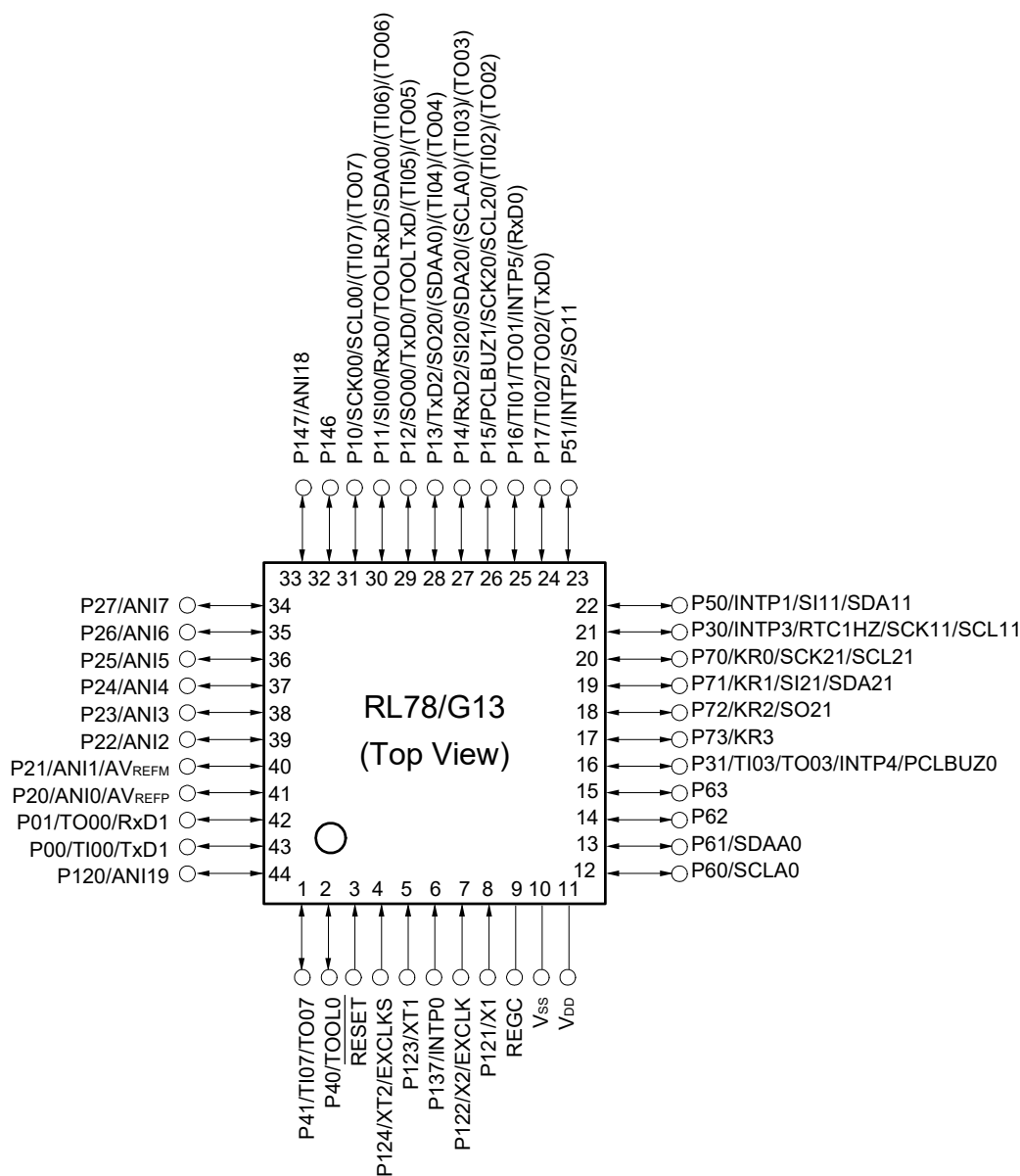

Caution Connect the REGC pin to V_{SS} via a capacitor (0.47 to 1 μF).

- Remarks 1.** For pin identification, see 1.4 Pin Identification.
- 2.** Functions in parentheses in the above figure can be assigned via settings in the peripheral I/O redirection register (PIOR). Refer to Figure 4-8 Format of Peripheral I/O Redirection Register (PIOR).

1.3.9 48-pin products

- 48-pin plastic LFQFP (7 × 7 mm, 0.5-mm pitch)

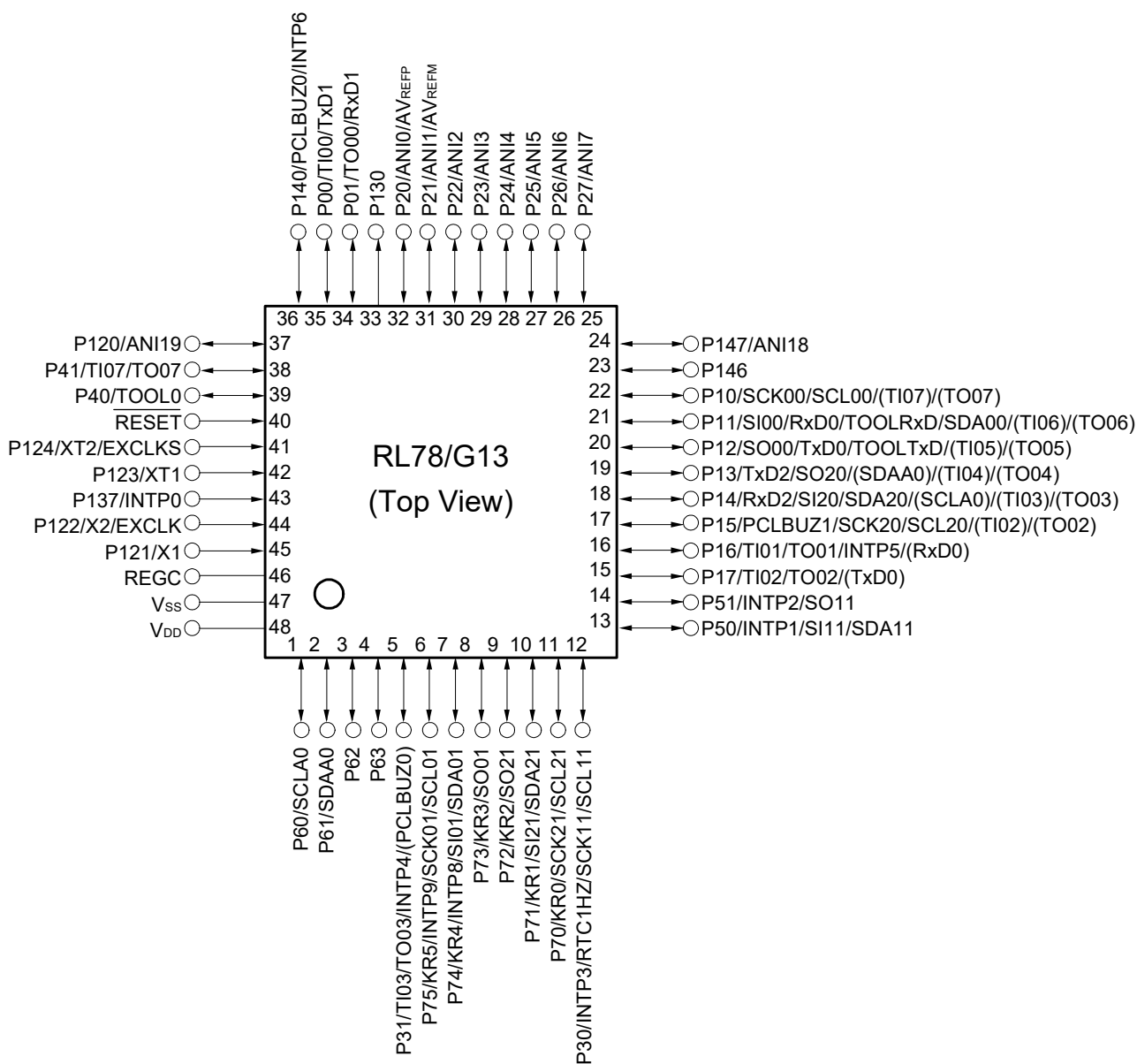

Caution Connect the REGC pin to V_{SS} via a capacitor (0.47 to 1 μF).

- Remarks 1.** For pin identification, see 1.4 Pin Identification.
- 2.** Functions in parentheses in the above figure can be assigned via settings in the peripheral I/O redirection register (PIOR). Refer to Figure 4-8 Format of Peripheral I/O Redirection Register (PIOR).

- 48-pin plastic HWQFN (7 × 7 mm, 0.5-mm pitch)

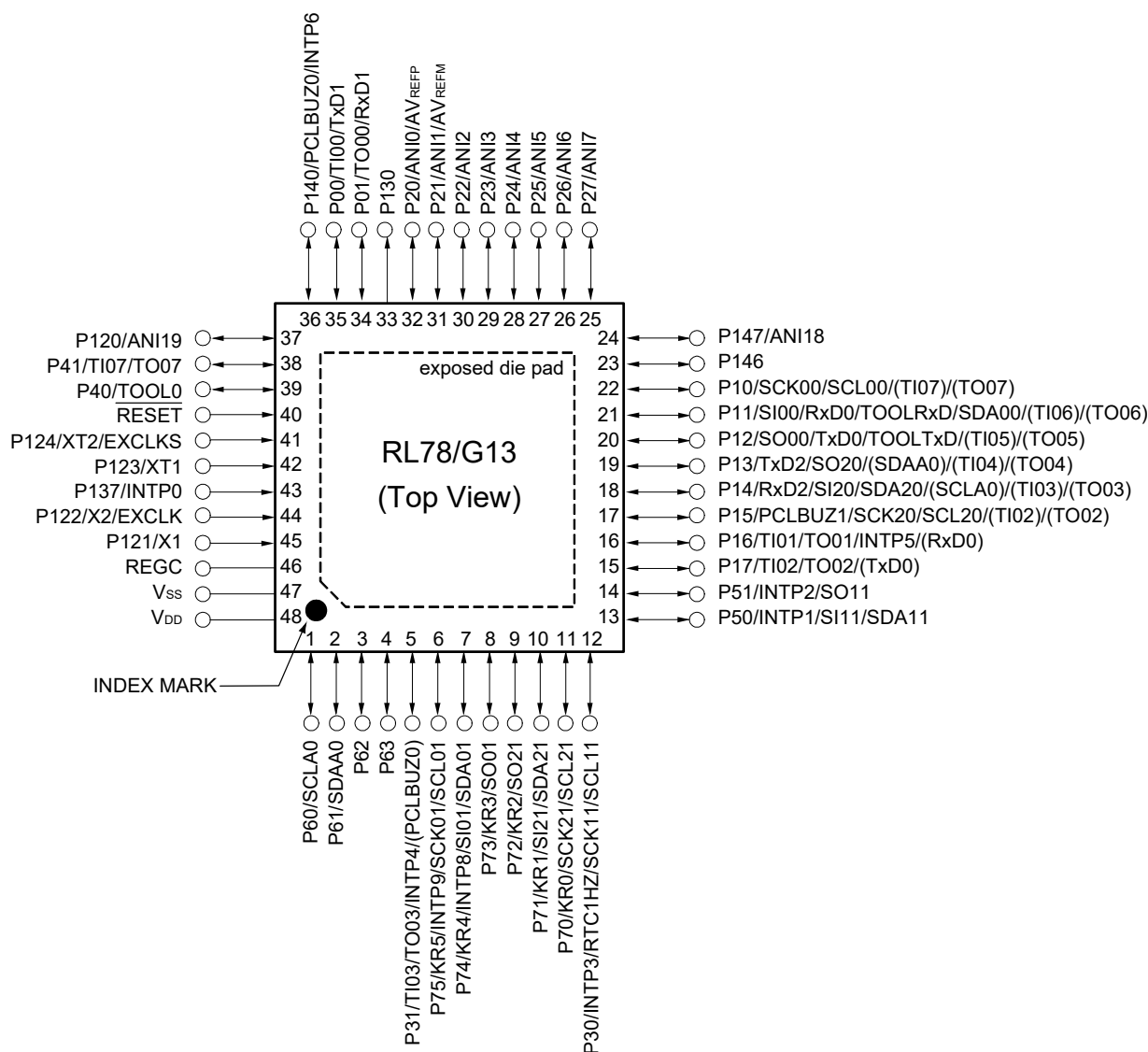

Caution Connect the REGC pin to V_{SS} via a capacitor (0.47 to 1 μF).

Remarks 1. For pin identification, see 1.4 Pin Identification.

2. Functions in parentheses in the above figure can be assigned via settings in the peripheral I/O redirection register (PIOR). Refer to **Figure 4-8 Format of Peripheral I/O Redirection Register (PIOR)**.
3. It is recommended to connect an exposed die pad to V_{SS}.

1.3.10 52-pin products

- 52-pin plastic LQFP (10 × 10 mm, 0.65-mm pitch)

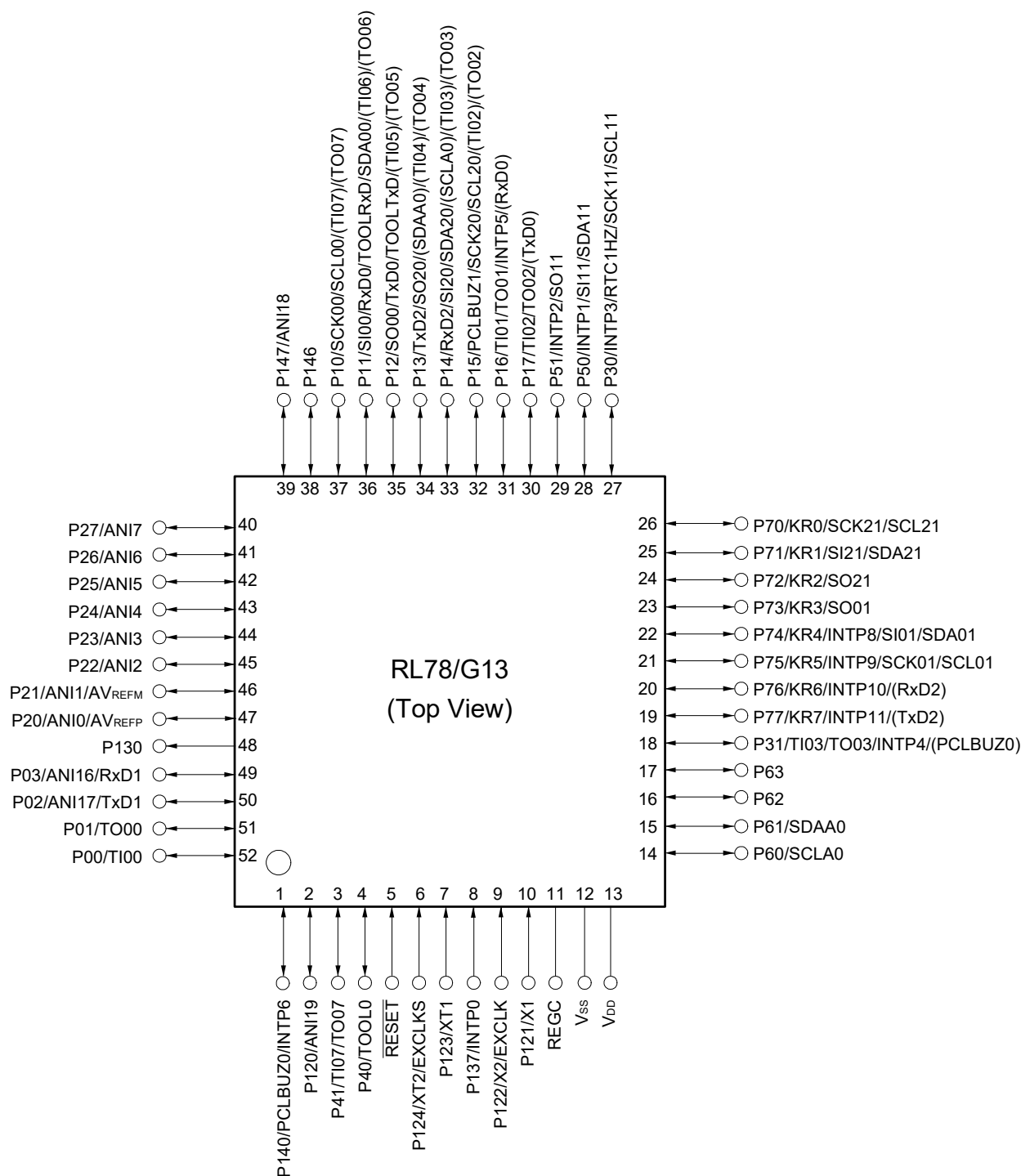

Caution Connect the REGC pin to V_{SS} via a capacitor (0.47 to 1 μF).

Remarks 1. For pin identification, see 1.4 Pin Identification.

2. Functions in parentheses in the above figure can be assigned via settings in the peripheral I/O redirection register (PIOR). Refer to **Figure 4-8 Format of Peripheral I/O Redirection Register (PIOR)**.

1.3.11 64-pin products

- 64-pin plastic LQFP (12 × 12 mm, 0.65-mm pitch)
- 64-pin plastic LFQFP (10 × 10 mm, 0.5-mm pitch)

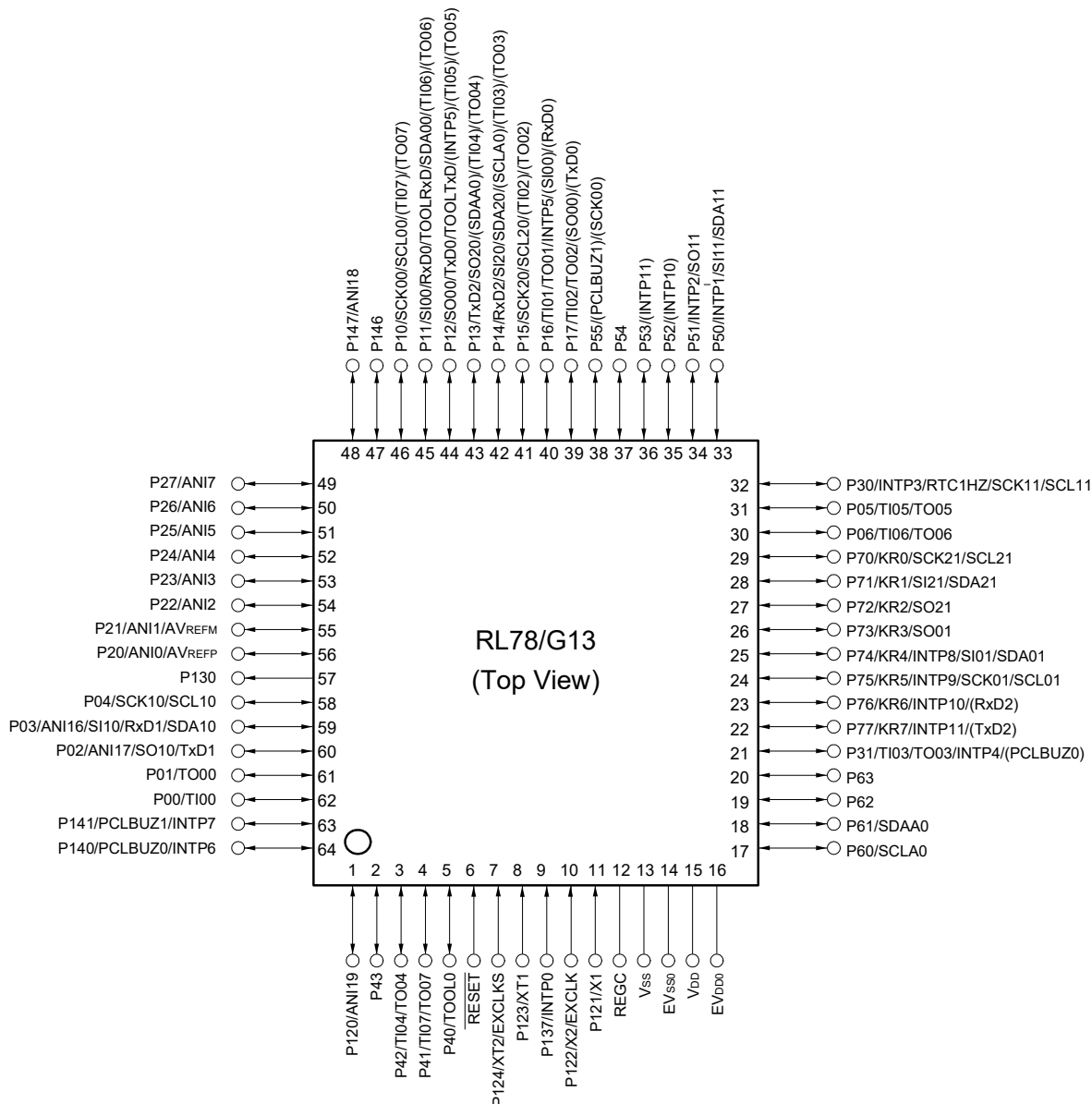

- Cautions**
1. Make EV_{SS0} pin the same potential as V_{SS} pin.
 2. Make V_{DD} pin the potential that is no less than EV_{DD0} pin.
 3. Connect the REGC pin to V_{SS} via a capacitor (0.47 to 1 μF).

- Remarks**
1. For pin identification, see 1.4 Pin Identification.
 2. When using the microcontroller for an application where the noise generated inside the microcontroller must be reduced, it is recommended to supply separate powers to the V_{DD} and EV_{DD0} pins and connect the V_{SS} and EV_{SS0} pins to separate ground lines.
 3. Functions in parentheses in the above figure can be assigned via settings in the peripheral I/O redirection register (PIOR). Refer to Figure 4-8 Format of Peripheral I/O Redirection Register (PIOR).

- 64-pin plastic VFBGA (4 × 4 mm, 0.4-mm pitch)

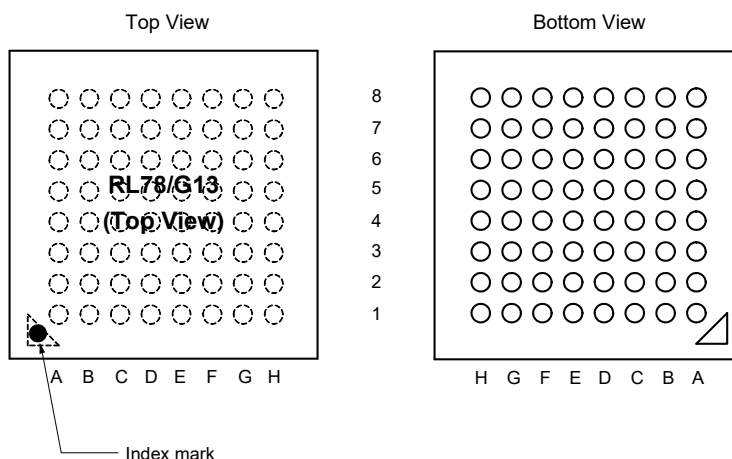

Pin No.	Name	Pin No.	Name	Pin No.	Name	Pin No.	Name
A1	P05/TI05/TO05	C1	P51/INTP2/SO11	E1	P13/TxD2/SO20/ (SDAA0)/(TI04)/(TO04)	G1	P146
A2	P30/INTP3/RTC1HZ /SCK11/SCL11	C2	P71/KR1/SI21/SDA21	E2	P14/RxD2/SI20/SDA20 /(SCLA0)/(TI03)/(TO03)	G2	P25/ANI5
A3	P70/KR0/SCK21 /SCL21	C3	P74/KR4/INTP8/SI01 /SDA01	E3	P15/SCK20/SCL20/ (TI02)/(TO02)	G3	P24/ANI4
A4	P75/KR5/INTP9 /SCK01/SCL01	C4	P52/(INTP10)	E4	P16/TI01/TO01/INTP5 /(SI00)/(RxD0)	G4	P22/ANI2
A5	P77/KR7/INTP11/ (TxD2)	C5	P53/(INTP11)	E5	P03/ANI16/SI10/RxD1 /SDA10	G5	P130
A6	P61/SDAA0	C6	P63	E6	P41/TI07/TO07	G6	P02/ANI17/SO10/TxD1
A7	P60/SCLA0	C7	V _{SS}	E7	RESET	G7	P00/TI00
A8	EV _{DD0}	C8	P121/X1	E8	P137/INTP0	G8	P124/XT2/EXCLKS
B1	P50/INTP1/SI11 /SDA11	D1	P55/(PCLBUZ1)/ (SCK00)	F1	P10/SCK00/SCL00/ (TI07)/(TO07)	H1	P147/ANI18
B2	P72/KR2/SO21	D2	P06/TI06/TO06	F2	P11/SI00/RxD0 /TOOLRxD/SDA00/ (TI06)/(TO06)	H2	P27/ANI7
B3	P73/KR3/SO01	D3	P17/TI02/TO02/ (SO00)/(TxD0)	F3	P12/SO00/TxD0 /TOOLTxD/(INTP5)/ (TI05)/(TO05)	H3	P26/ANI6
B4	P76/KR6/INTP10/ (RxD2)	D4	P54	F4	P21/ANI1/AV _{REFM}	H4	P23/ANI3
B5	P31/TI03/TO03 /INTP4/(PCLBUZ0)	D5	P42/TI04/TO04	F5	P04/SCK10/SCL10	H5	P20/ANI0/AV _{REFP}
B6	P62	D6	P40/TOOL0	F6	P43	H6	P141/PCLBUZ1/INTP7
B7	V _{DD}	D7	REGC	F7	P01/TO00	H7	P140/PCLBUZ0/INTP6
B8	EV _{SS0}	D8	P122/X2/EXCLK	F8	P123/XT1	H8	P120/ANI19

- Cautions**
1. Make EV_{SS0} pin the same potential as V_{SS} pin.
 2. Make V_{DD} pin the potential that is no less than EV_{DD0} pin.
 3. Connect the REGC pin to V_{SS} via a capacitor (0.47 to 1 μF).

- Remarks**
1. For pin identification, see 1.4 Pin Identification.
 2. When using the microcontroller for an application where the noise generated inside the microcontroller must be reduced, it is recommended to supply separate powers to the V_{DD} and EV_{DD0} pins and connect the V_{SS} and EV_{SS0} pins to separate ground lines.
 3. Functions in parentheses in the above figure can be assigned via settings in the peripheral I/O redirection register (PIOR). Refer to Figure 4-8 Format of Peripheral I/O Redirection Register (PIOR).

1.3.12 80-pin products

- 80-pin plastic LQFP (14 × 14 mm, 0.65-mm pitch)
- 80-pin plastic LFQFP (12 × 12 mm, 0.5-mm pitch)

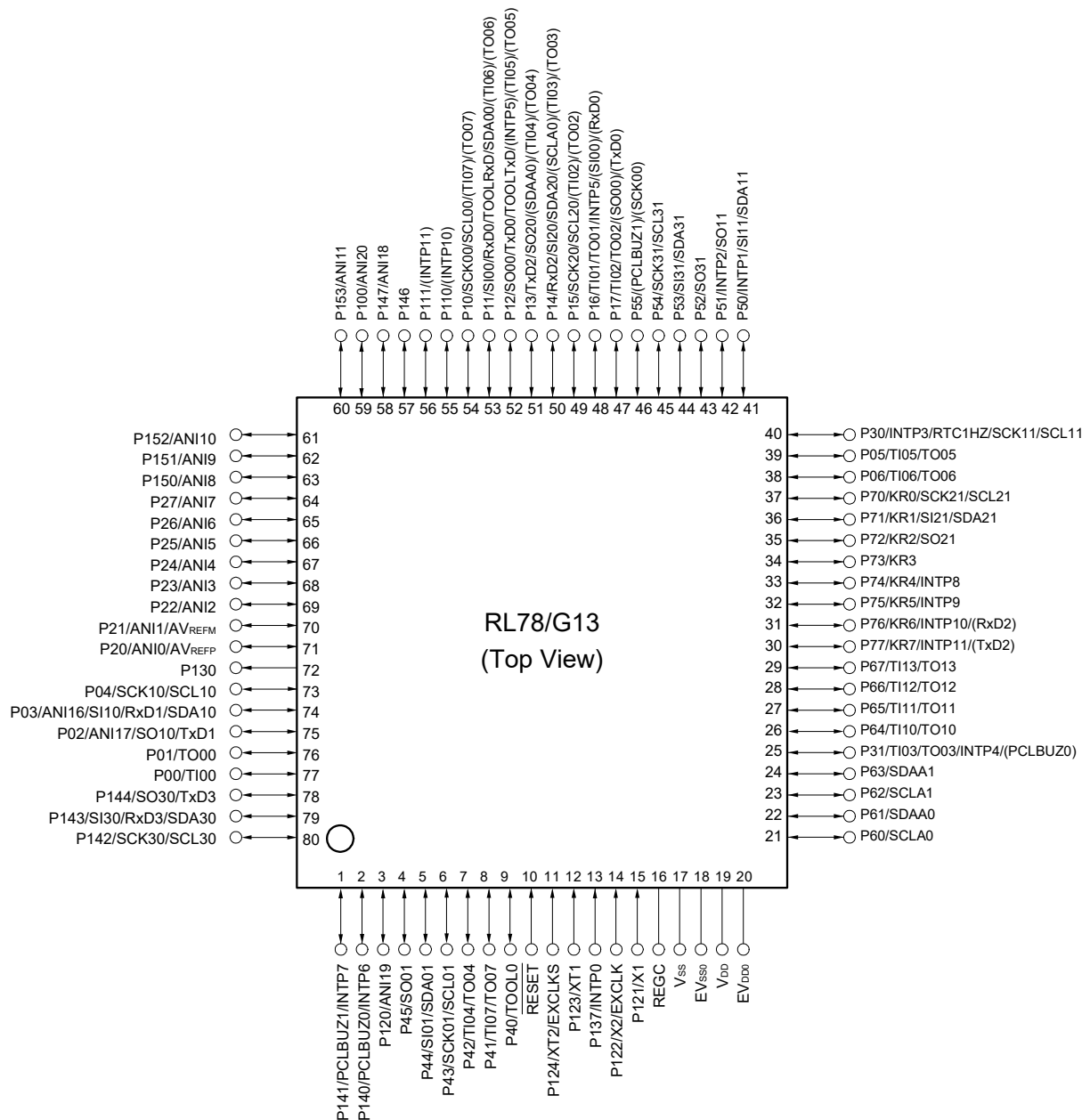

- Cautions**
1. Make EV_{SS0} pin the same potential as V_{SS} pin.
 2. Make V_{DD} pin the potential that is no less than EV_{DD0} pin.
 3. Connect the REGC pin to V_{SS} via a capacitor (0.47 to 1 μF).

- Remarks**
1. For pin identification, see 1.4 Pin Identification.
 2. When using the microcontroller for an application where the noise generated inside the microcontroller must be reduced, it is recommended to supply separate powers to the V_{DD} and EV_{DD0} pins and connect the V_{SS} and EV_{SS0} pins to separate ground lines.
 3. Functions in parentheses in the above figure can be assigned via settings in the peripheral I/O redirection register (PIOR). Refer to **Figure 4-8 Format of Peripheral I/O Redirection Register (PIOR)**.

1.3.13 100-pin products

- 100-pin plastic LFQFP (14 × 14 mm, 0.5-mm pitch)

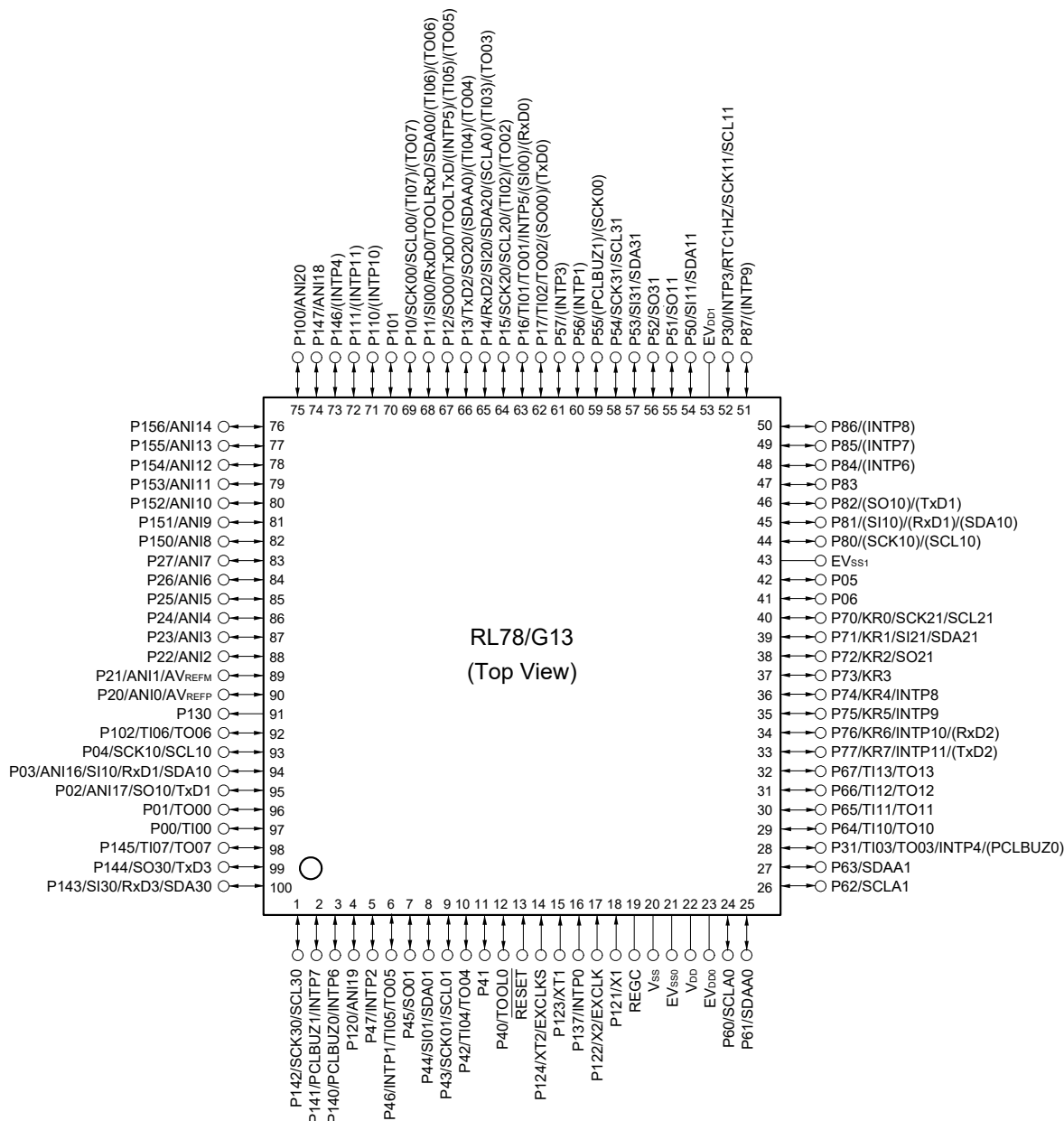

- Cautions**
1. Make EV_{SS0} and EV_{SS1} pins the same potential as V_{SS} pin.
 2. Make V_{DD} pin the potential that is no less than EV_{DD0} and EV_{DD1} pins (EV_{DD0} = EV_{DD1}).
 3. Connect the REGC pin to V_{SS} via a capacitor (0.47 to 1 μF).

- Remarks**
1. For pin identification, see 1.4 Pin Identification.
 2. When using the microcontroller for an application where the noise generated inside the microcontroller must be reduced, it is recommended to supply separate powers to the V_{DD}, EV_{DD0} and EV_{DD1} pins and connect the V_{SS}, EV_{SS0} and EV_{SS1} pins to separate ground lines.
 3. Functions in parentheses in the above figure can be assigned via settings in the peripheral I/O redirection register (PIOR). Refer to **Figure 4-8 Format of Peripheral I/O Redirection Register (PIOR)**.

- 100-pin plastic LQFP (14 × 20 mm, 0.65-mm pitch)

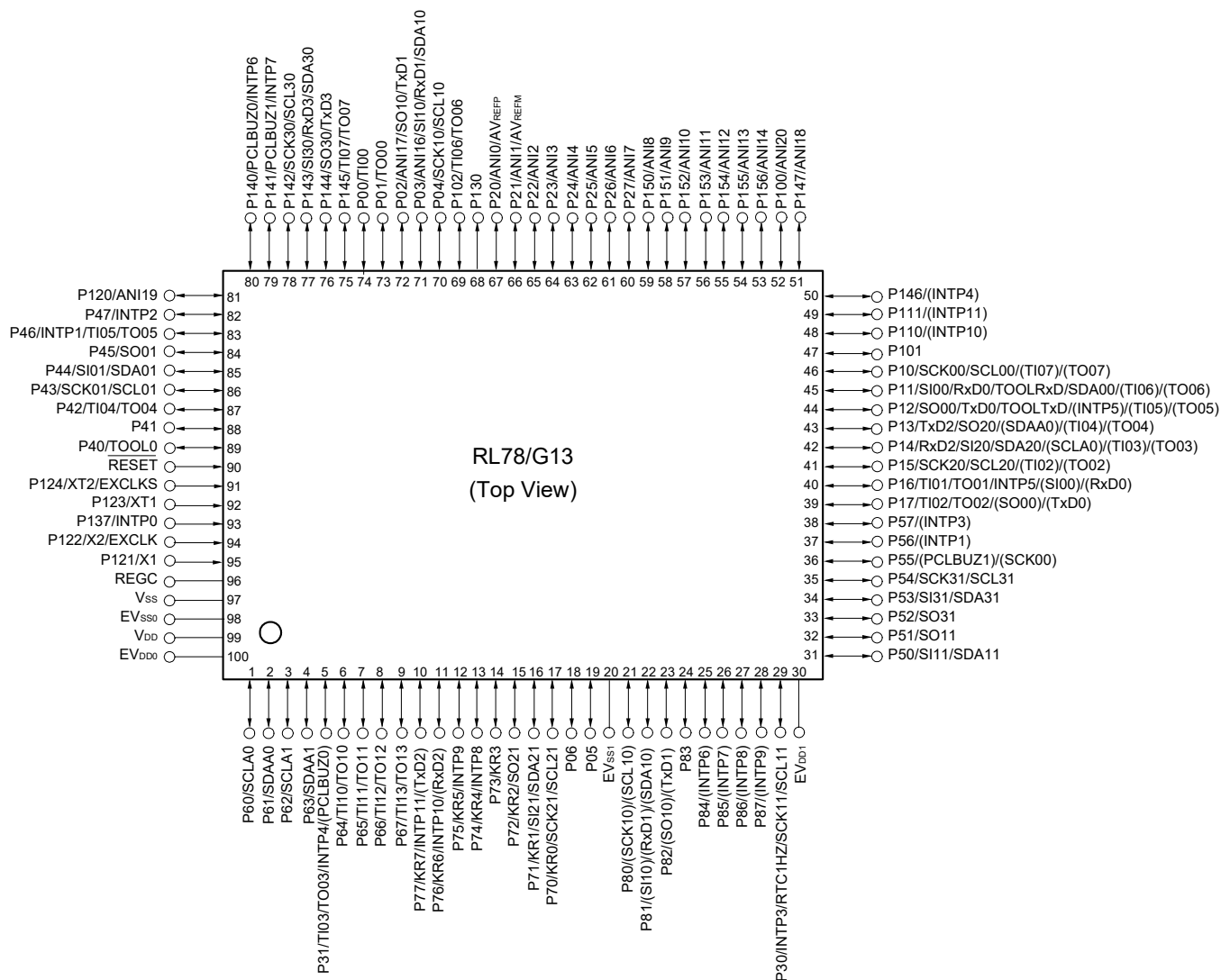

- Cautions**
1. Make EV_{SS0} and EV_{SS1} pins the same potential as V_{SS} pin.
 2. Make V_{DD} pin the potential that is no less than EV_{DD0} and EV_{DD1} pins (EV_{DD0} = EV_{DD1}).
 3. Connect the REGC pin to V_{SS} via a capacitor (0.47 to 1 μF).

- Remarks**
1. For pin identification, see 1.4 Pin Identification.
 2. When using the microcontroller for an application where the noise generated inside the microcontroller must be reduced, it is recommended to supply separate powers to the V_{DD}, EV_{DD0} and EV_{DD1} pins and connect the V_{SS}, EV_{SS0} and EV_{SS1} pins to separate ground lines.
 3. Functions in parentheses in the above figure can be assigned via settings in the peripheral I/O redirection register (PIOR). Refer to **Figure 4-8 Format of Peripheral I/O Redirection Register (PIOR)**.

1.3.14 128-pin products

- 128-pin plastic LFQFP (14 × 20 mm, 0.5-mm pitch)

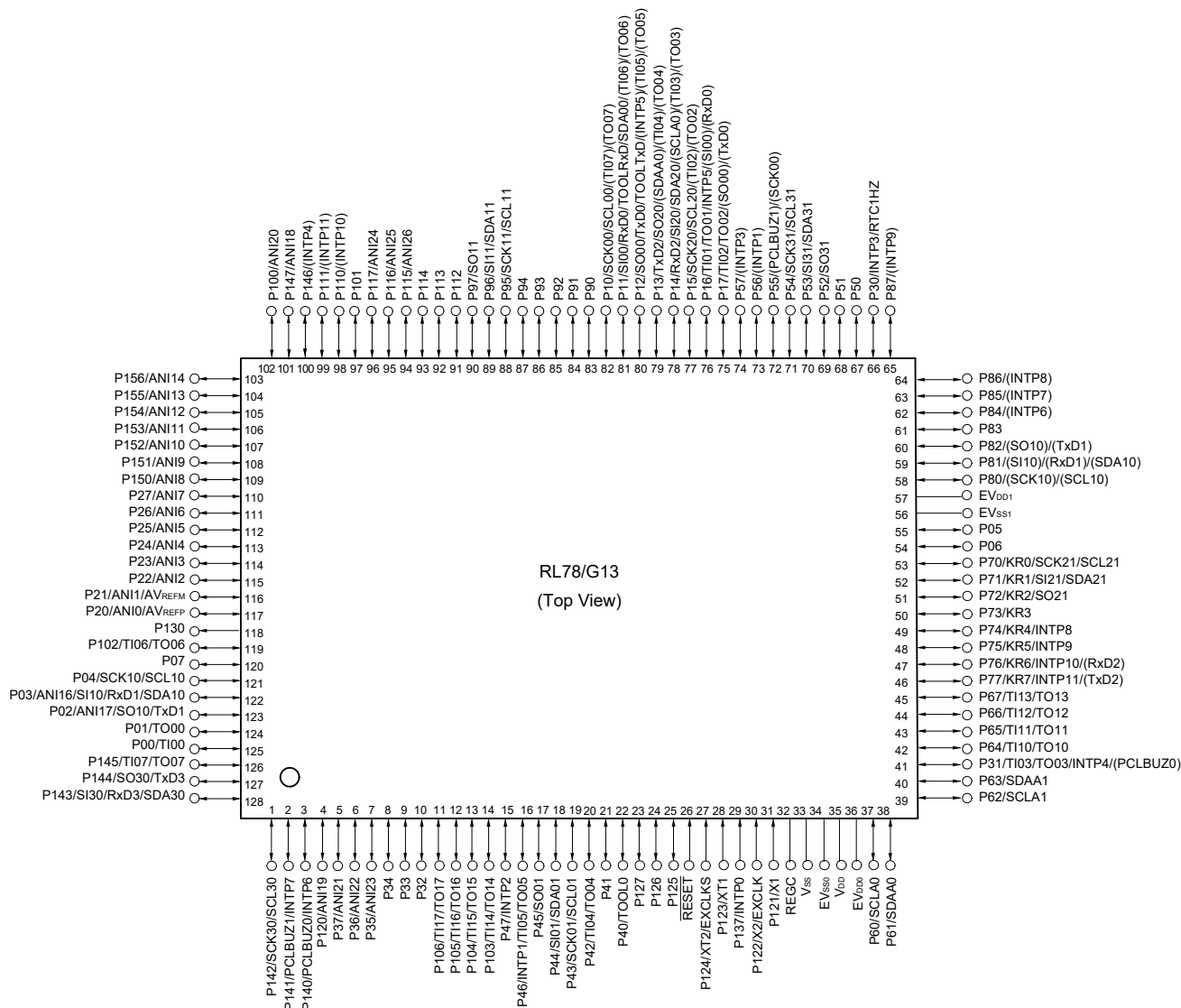

- Cautions**
1. Make EV_{SS0} and EV_{SS1} pins the same potential as V_{SS} pin.
 2. Make V_{DD} pin the potential that is no less than EV_{DD0} and EV_{DD1} pins (EV_{DD0} = EV_{DD1}).
 3. Connect the REGC pin to V_{SS} via a capacitor (0.47 to 1 μF).

- Remarks**
1. For pin identification, see 1.4 Pin Identification.
 2. When using the microcontroller for an application where the noise generated inside the microcontroller must be reduced, it is recommended to supply separate powers to the V_{DD}, EV_{DD0} and EV_{DD1} pins and connect the V_{SS}, EV_{SS0} and EV_{SS1} pins to separate ground lines.
 3. Functions in parentheses in the above figure can be assigned via settings in the peripheral I/O redirection register (PIOR). Refer to Figure 4-8 Format of Peripheral I/O Redirection Register (PIOR).

1.4 Pin Identification

ANI0 to ANI14,		REGC:	Regulator capacitance
ANI16 to ANI26:	Analog input	RESET:	Reset
AVREFM:	A/D converter reference potential (– side) input	RTC1HZ:	Real-time clock correction clock (1 Hz) output
AVREFP:	A/D converter reference potential (+ side) input	RxD0 to RxD3:	Receive data
EVDD0, EVDD1:	Power supply for port	SCLA0, SCLA1,	
EVSS0, EVSS1:	Ground for port	SCK00, SCK01, SCK10,	
EXCLK:	External clock input (Main system clock)	SCK11, SCK20, SCK21,	
EXCLKS:	External clock input (Subsystem clock)	SCK30, SCK31:	Serial clock input/output
INTP0 to INTP11:	Interrupt request from peripheral	SCL00, SCL01, SCL10,	
KR0 to KR7:	Key return	SCL11, SCL20, SCL21,	
P00 to P07:	Port 0	SCL30, SCL31:	Serial clock output
P10 to P17:	Port 1	SDAA0, SDAA1, SDA00,	
P20 to P27:	Port 2	SDA01, SDA10, SDA11,	
P30 to P37:	Port 3	SDA20, SDA21, SDA30,	
P40 to P47:	Port 4	SDA31:	Serial data input/output
P50 to P57:	Port 5	SI00, SI01, SI10, SI11,	
P60 to P67:	Port 6	SI20, SI21, SI30, SI31:	Serial data input
P70 to P77:	Port 7	SO00, SO01, SO10,	
P80 to P87:	Port 8	SO11, SO20, SO21,	
P90 to P97:	Port 9	SO30, SO31:	Serial data output
P100 to P106:	Port 10	TI00 to TI07,	
P110 to P117:	Port 11	TI10 to TI17:	Timer input
P120 to P127:	Port 12	TO00 to TO07,	
P130, P137:	Port 13	TO10 to TO17:	Timer output
P140 to P147:	Port 14	TOOL0:	Data input/output for tool
P150 to P156:	Port 15	TOOLRxD, TOOLTxD:	Data input/output for external device
PCLBUZ0, PCLBUZ1:	Programmable clock output/buzzer output	TxD0 to TxD3:	Transmit data
		VDD:	Power supply
		VSS:	Ground
		X1, X2:	Crystal oscillator (main system clock)
		XT1, XT2:	Crystal oscillator (subsystem clock)

1.5 Block Diagram

1.5.1 20-pin products

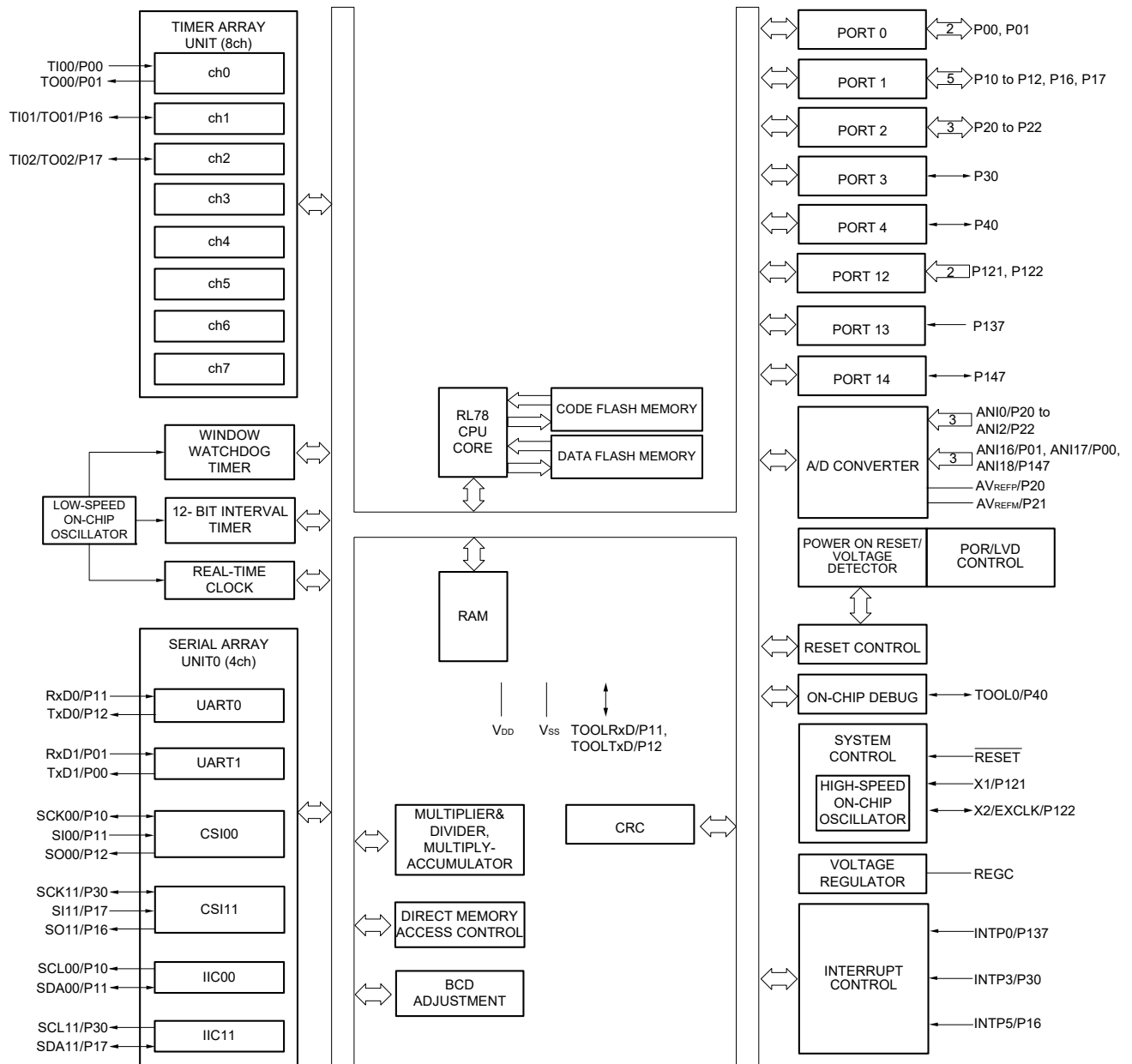

1.5.2 24-pin products

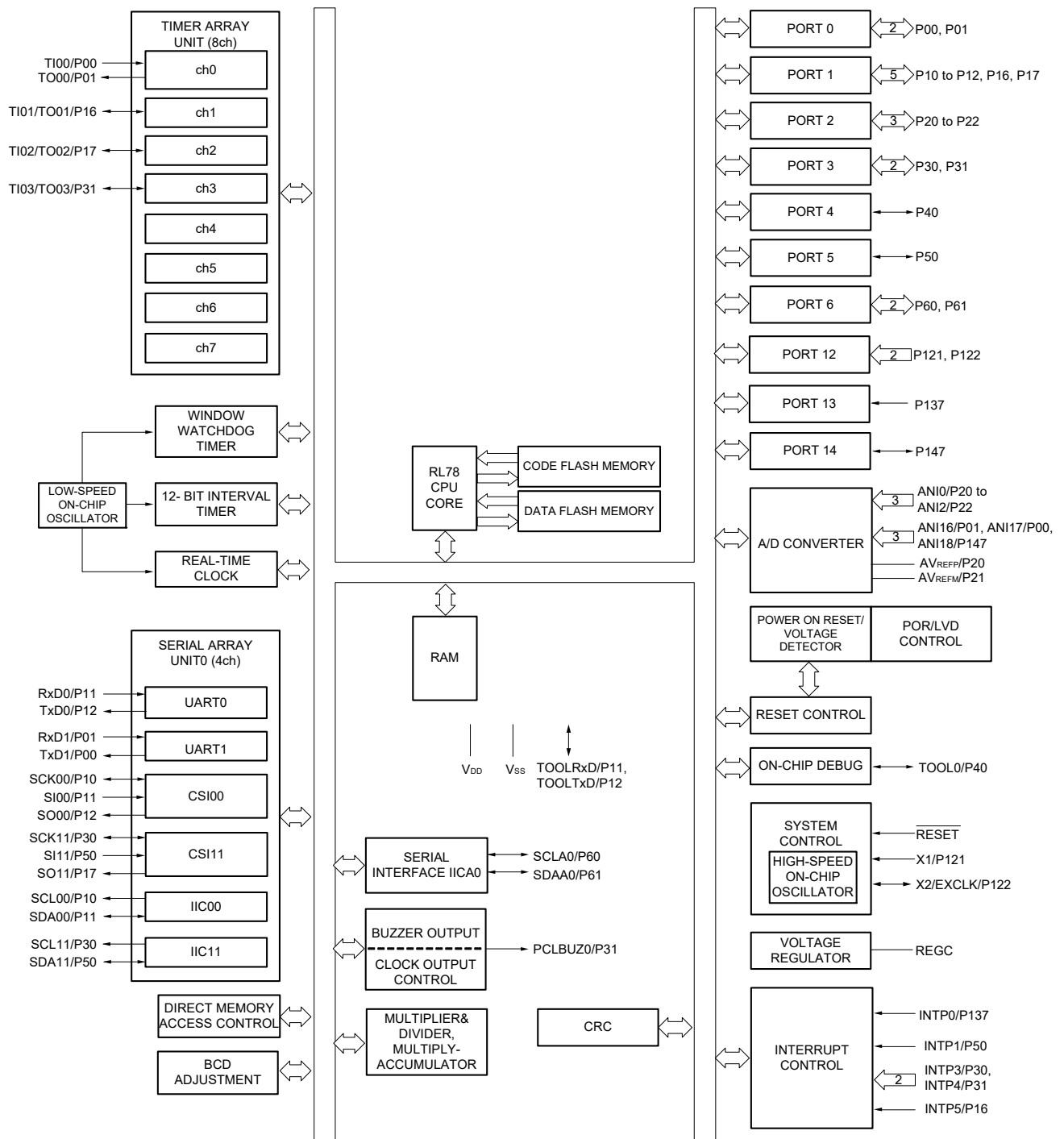

1.5.3 25-pin products

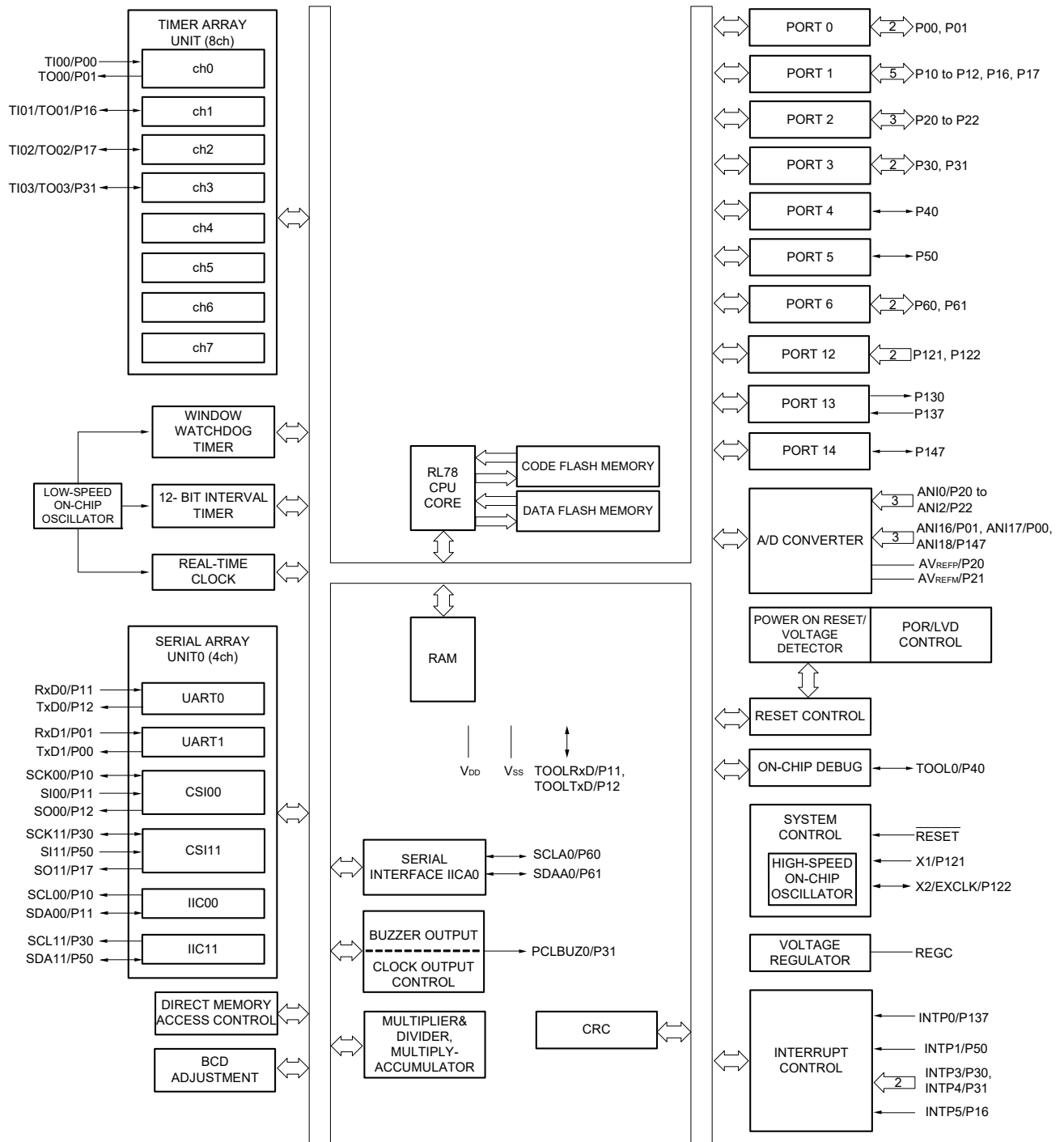

1.5.4 30-pin products

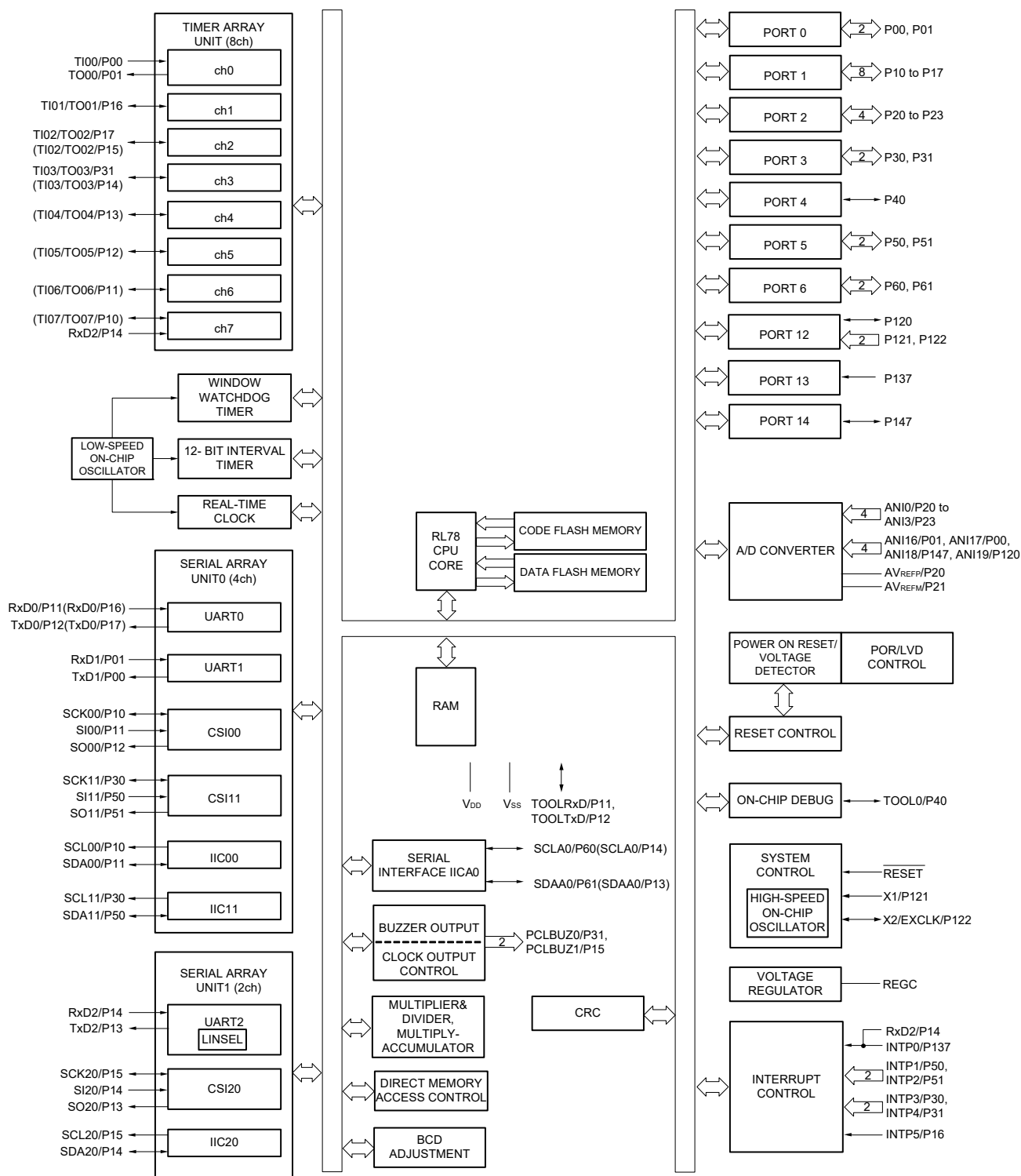

Remark Functions in parentheses in the above figure can be assigned via settings in the peripheral I/O redirection register (PIOR). Refer to **Figure 4-8 Format of Peripheral I/O Redirection Register (PIOR)**.

1.5.5 32-pin products

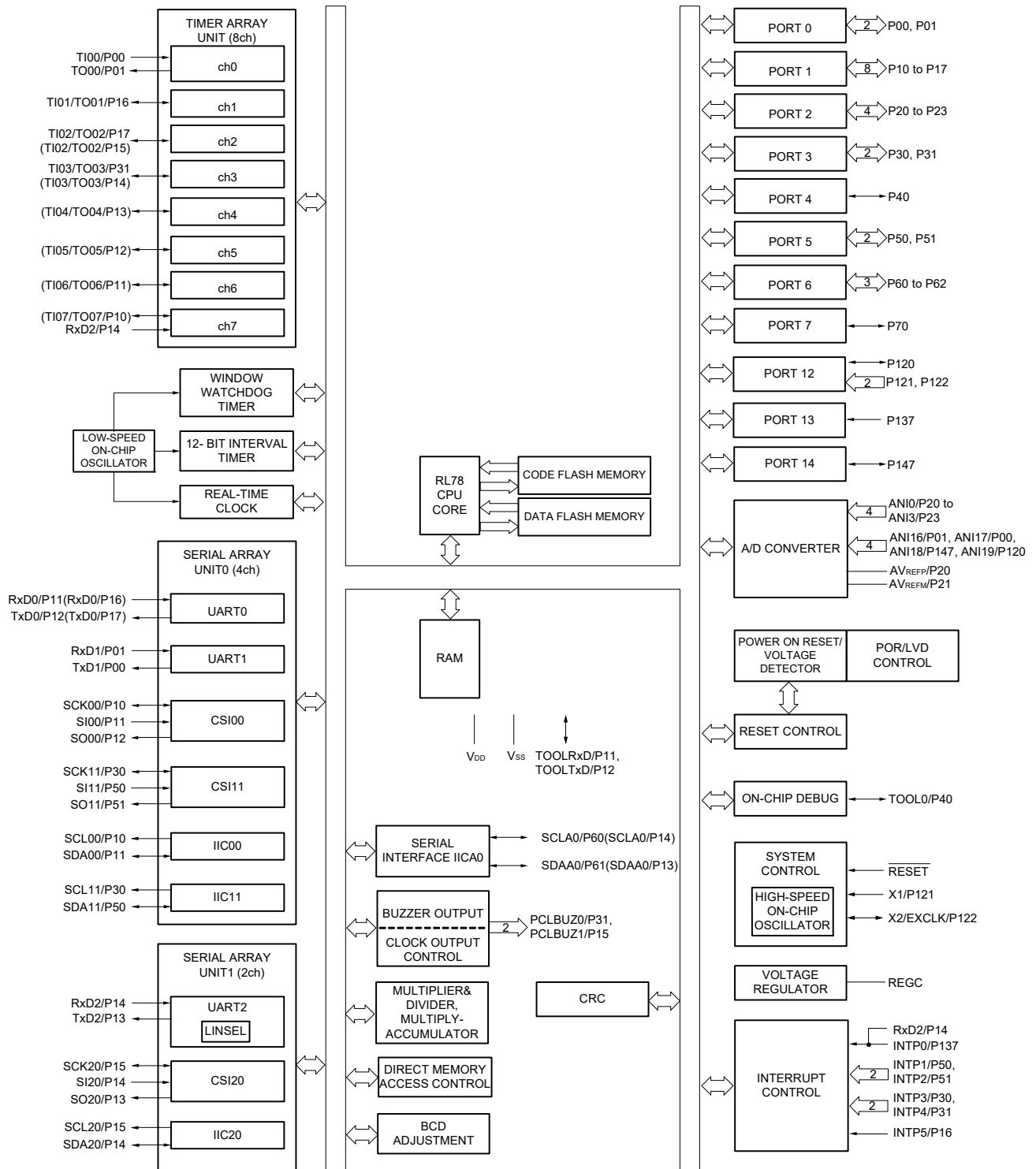

Remark Functions in parentheses in the above figure can be assigned via settings in the peripheral I/O redirection register (PIOR). Refer to **Figure 4-8 Format of Peripheral I/O Redirection Register (PIOR)**.

1.5.6 36-pin products

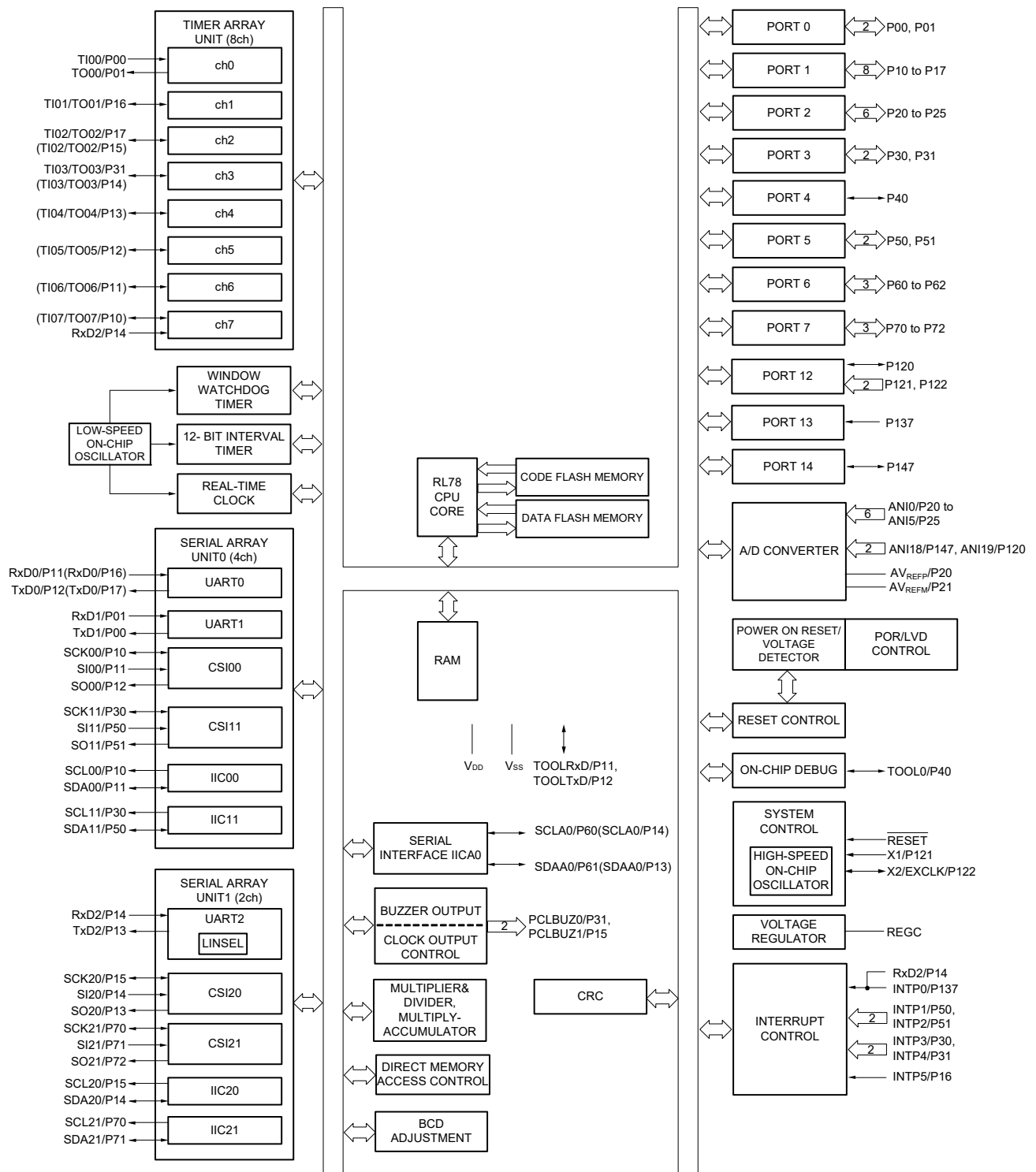

Remark Functions in parentheses in the above figure can be assigned via settings in the peripheral I/O redirection register (PIOR). Refer to **Figure 4-8 Format of Peripheral I/O Redirection Register (PIOR)**.

1.5.7 40-pin products

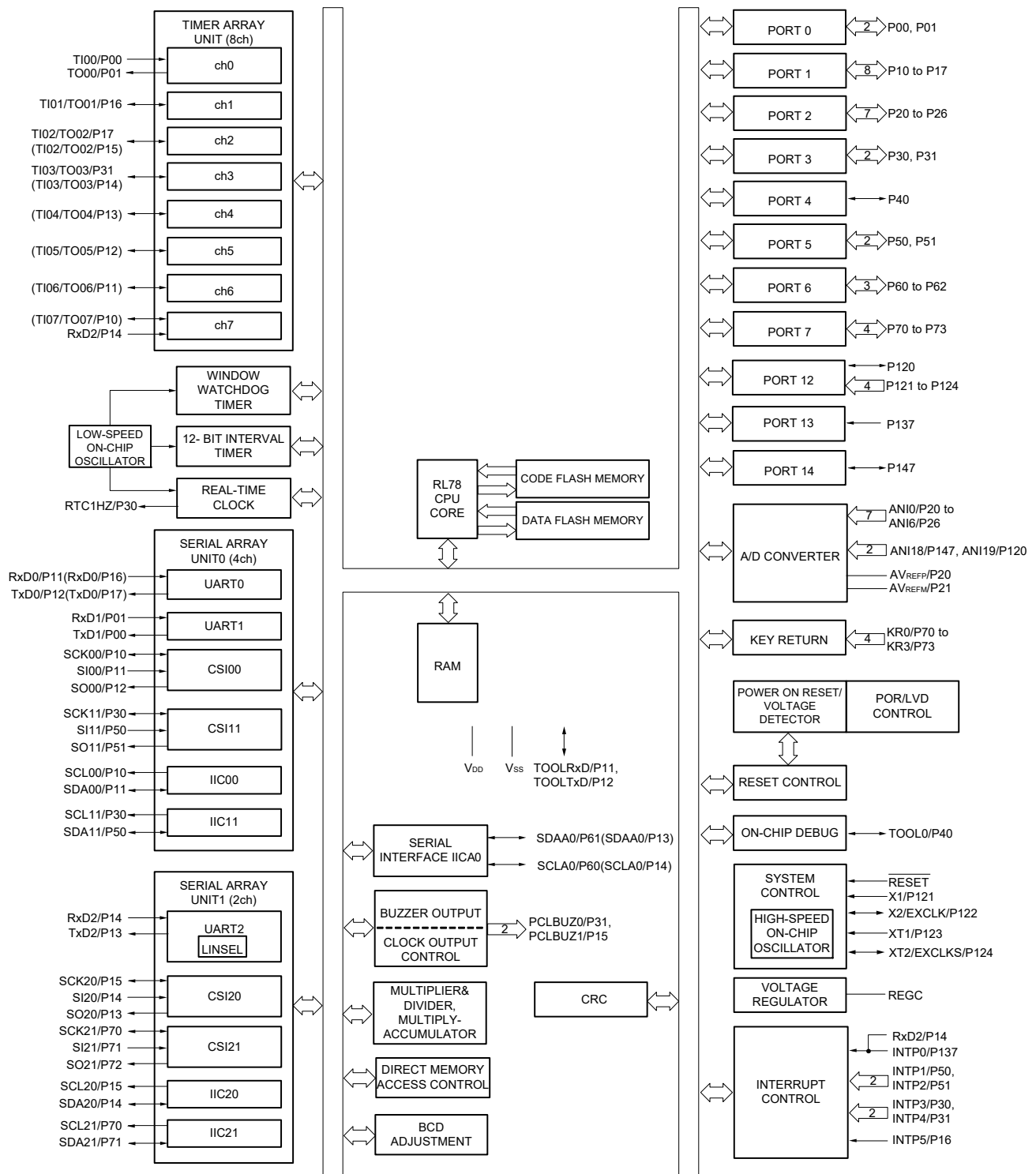

Remark Functions in parentheses in the above figure can be assigned via settings in the peripheral I/O redirection register (PIOR). Refer to **Figure 4-8 Format of Peripheral I/O Redirection Register (PIOR)**.

1.5.8 44-pin products

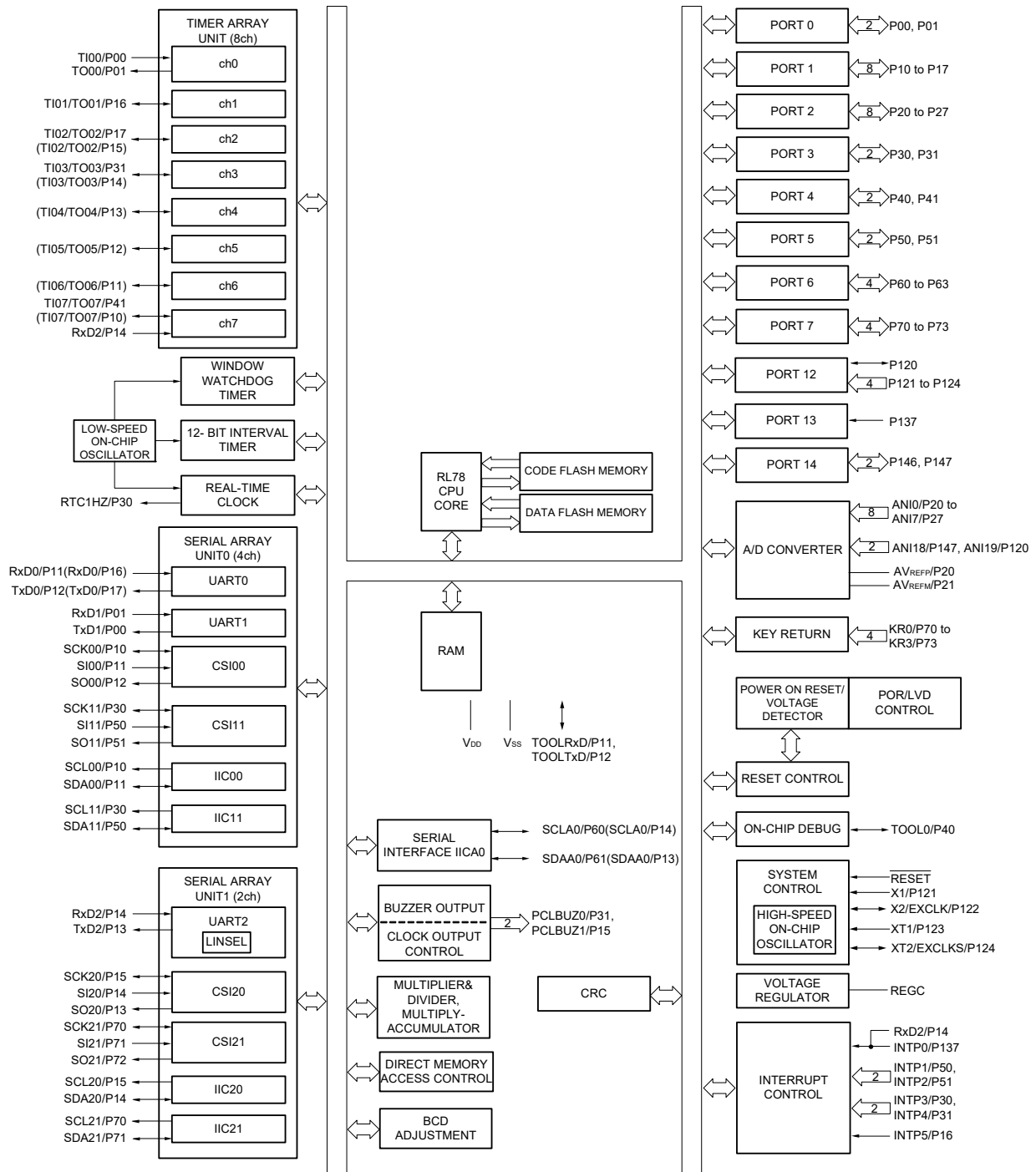

Remark Functions in parentheses in the above figure can be assigned via settings in the peripheral I/O redirection register (PIOR). Refer to **Figure 4-8 Format of Peripheral I/O Redirection Register (PIOR)**.

1.5.9 48-pin products

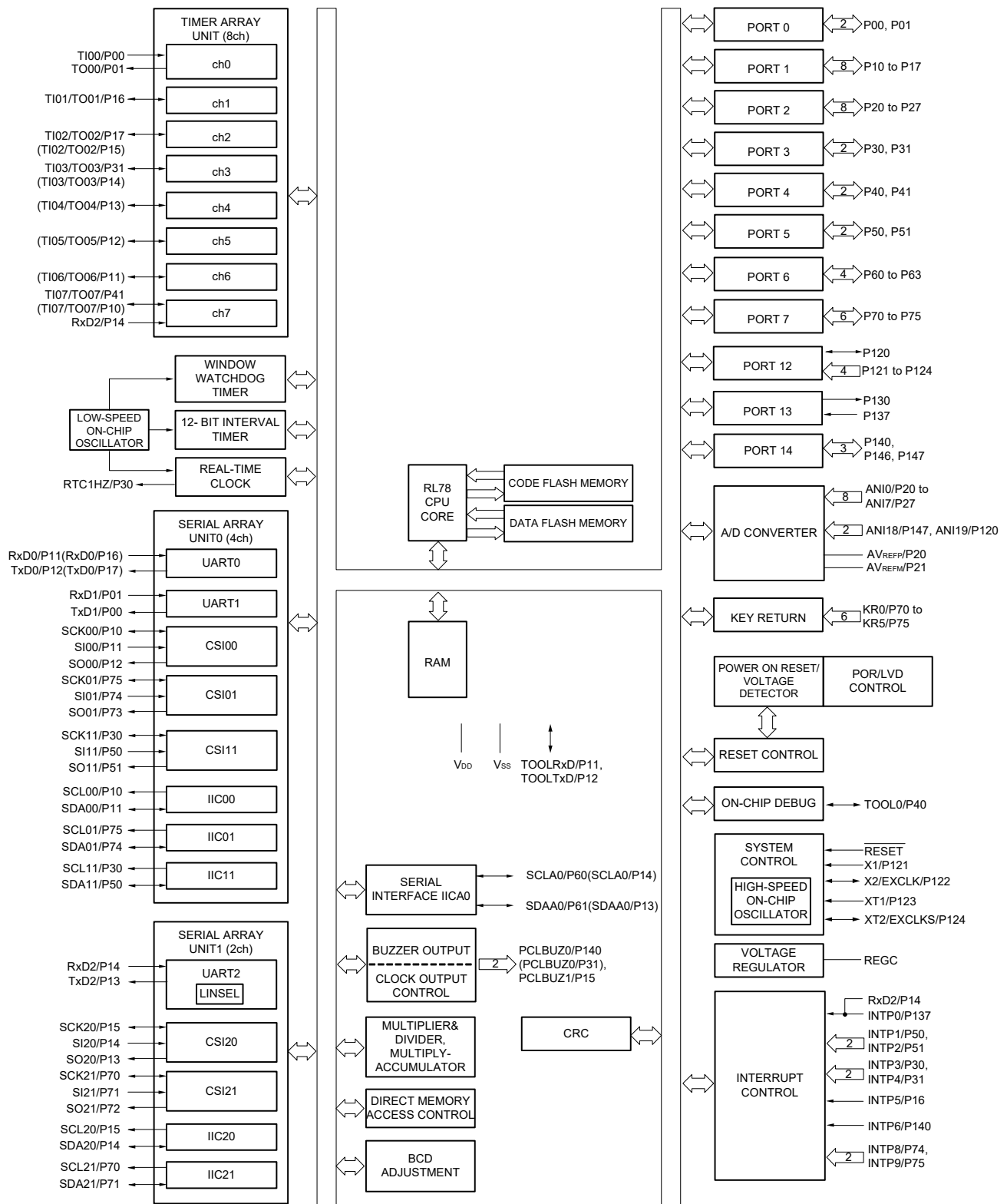

Remark Functions in parentheses in the above figure can be assigned via settings in the peripheral I/O redirection register (PIOR). Refer to **Figure 4-8 Format of Peripheral I/O Redirection Register (PIOR)**.

1.5.10 52-pin products

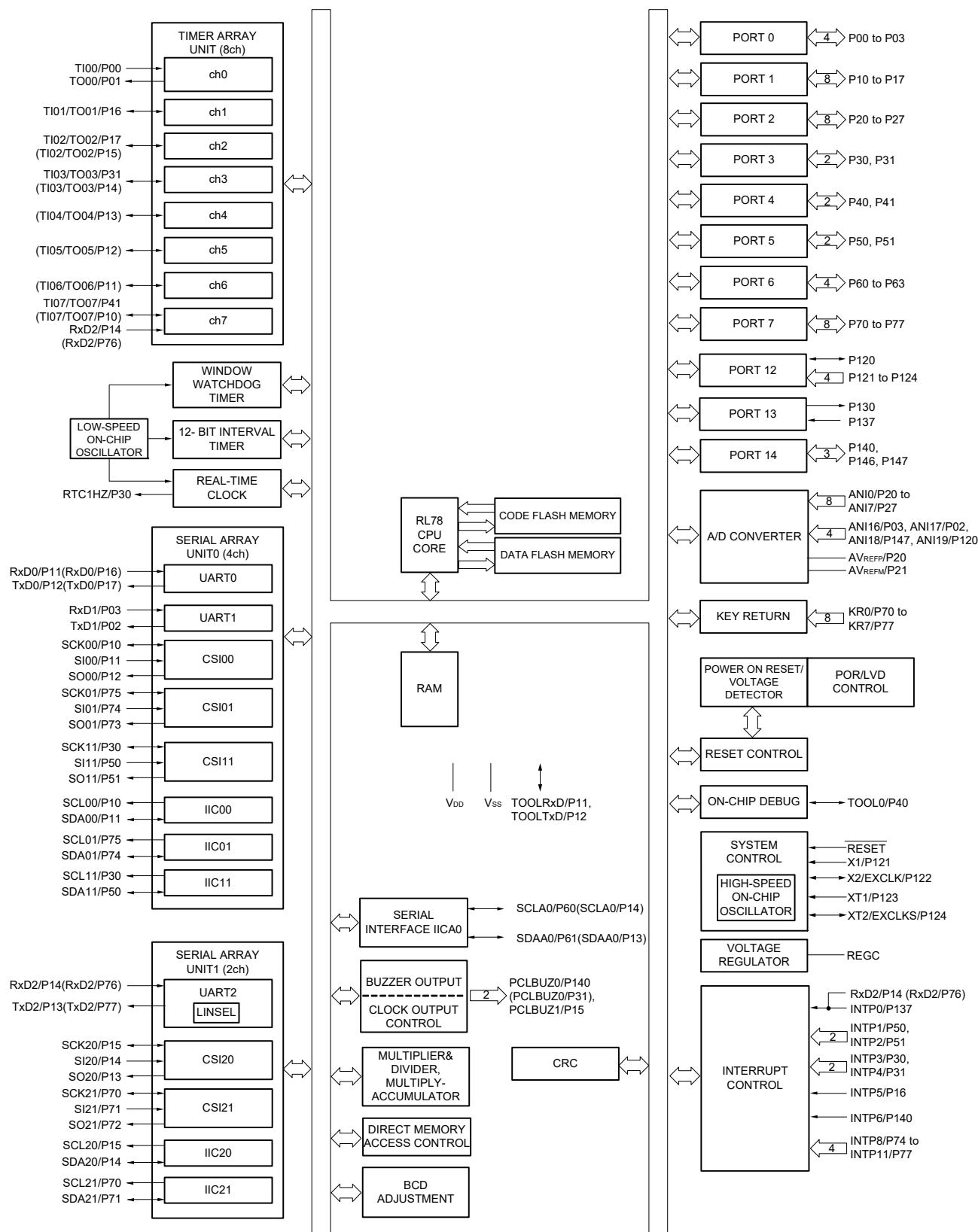

Remark Functions in parentheses in the above figure can be assigned via settings in the peripheral I/O redirection register (PIOR). Refer to **Figure 4-8 Format of Peripheral I/O Redirection Register (PIOR)**.

1.5.11 64-pin products

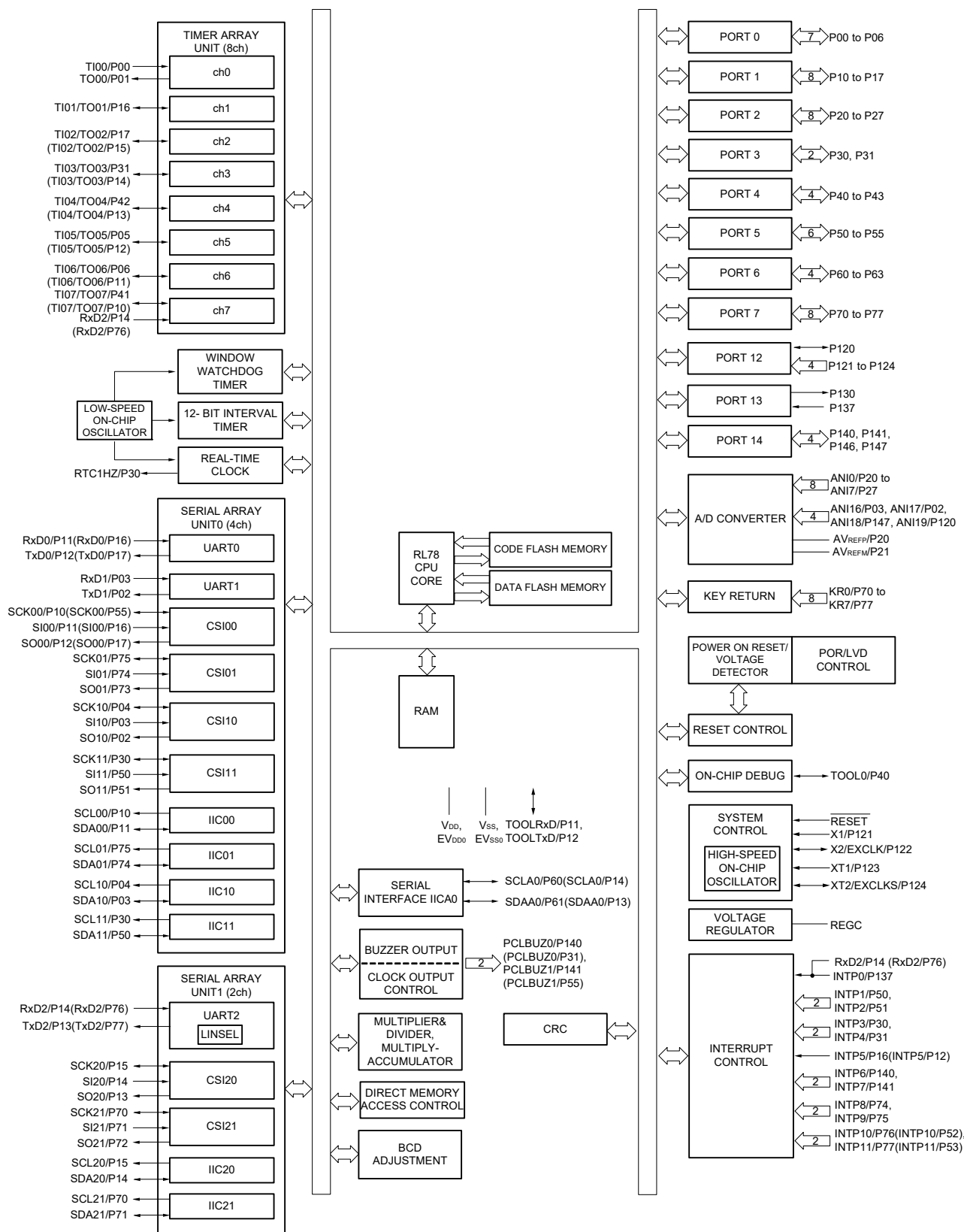

Remark Functions in parentheses in the above figure can be assigned via settings in the peripheral I/O redirection register (PIOR). Refer to **Figure 4-8 Format of Peripheral I/O Redirection Register (PIOR)**.

1.5.12 80-pin products

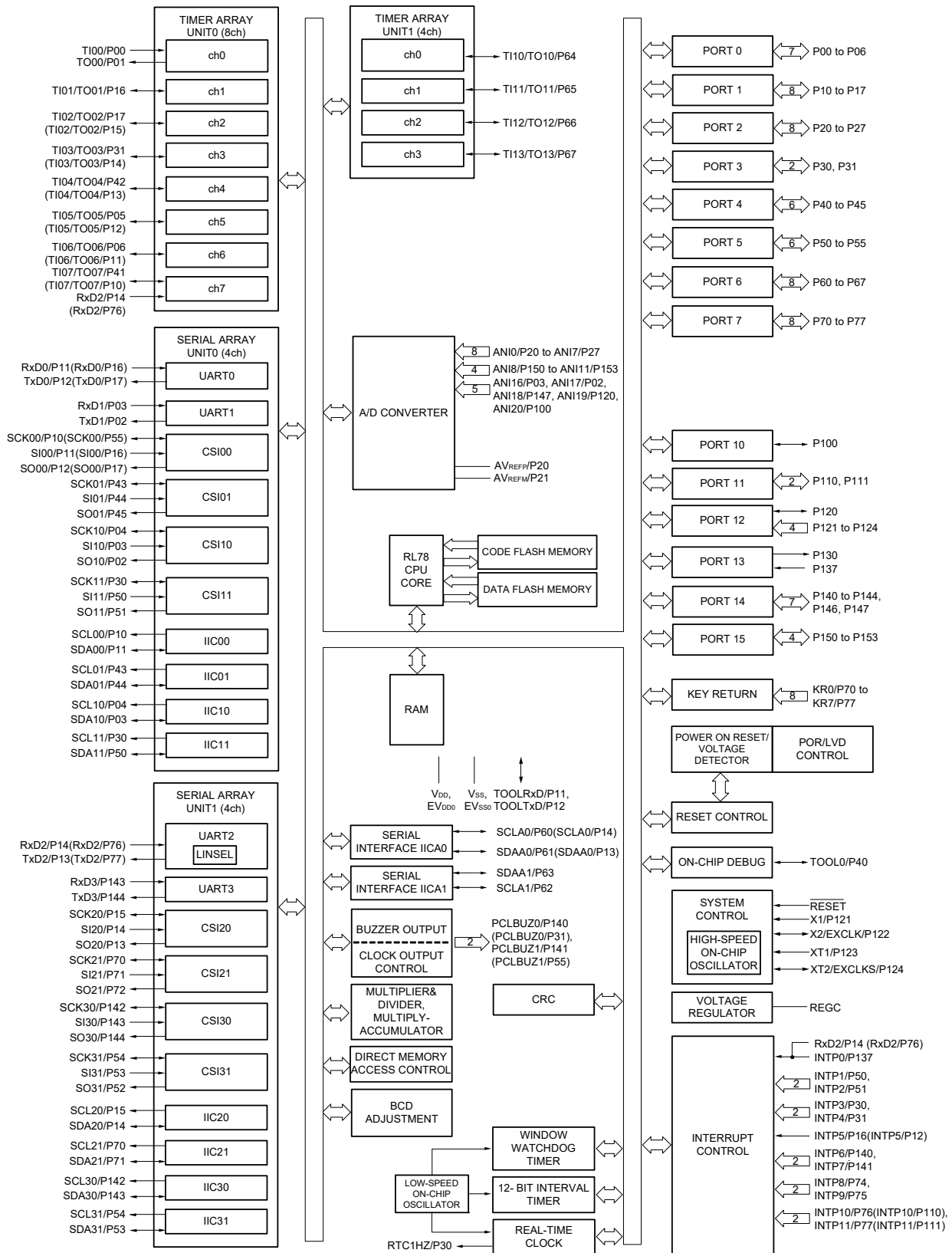

Remark Functions in parentheses in the above figure can be assigned via settings in the peripheral I/O redirection register (PIOR). Refer to **Figure 4-8 Format of Peripheral I/O Redirection Register (PIOR)**.

1.5.13 100-pin products

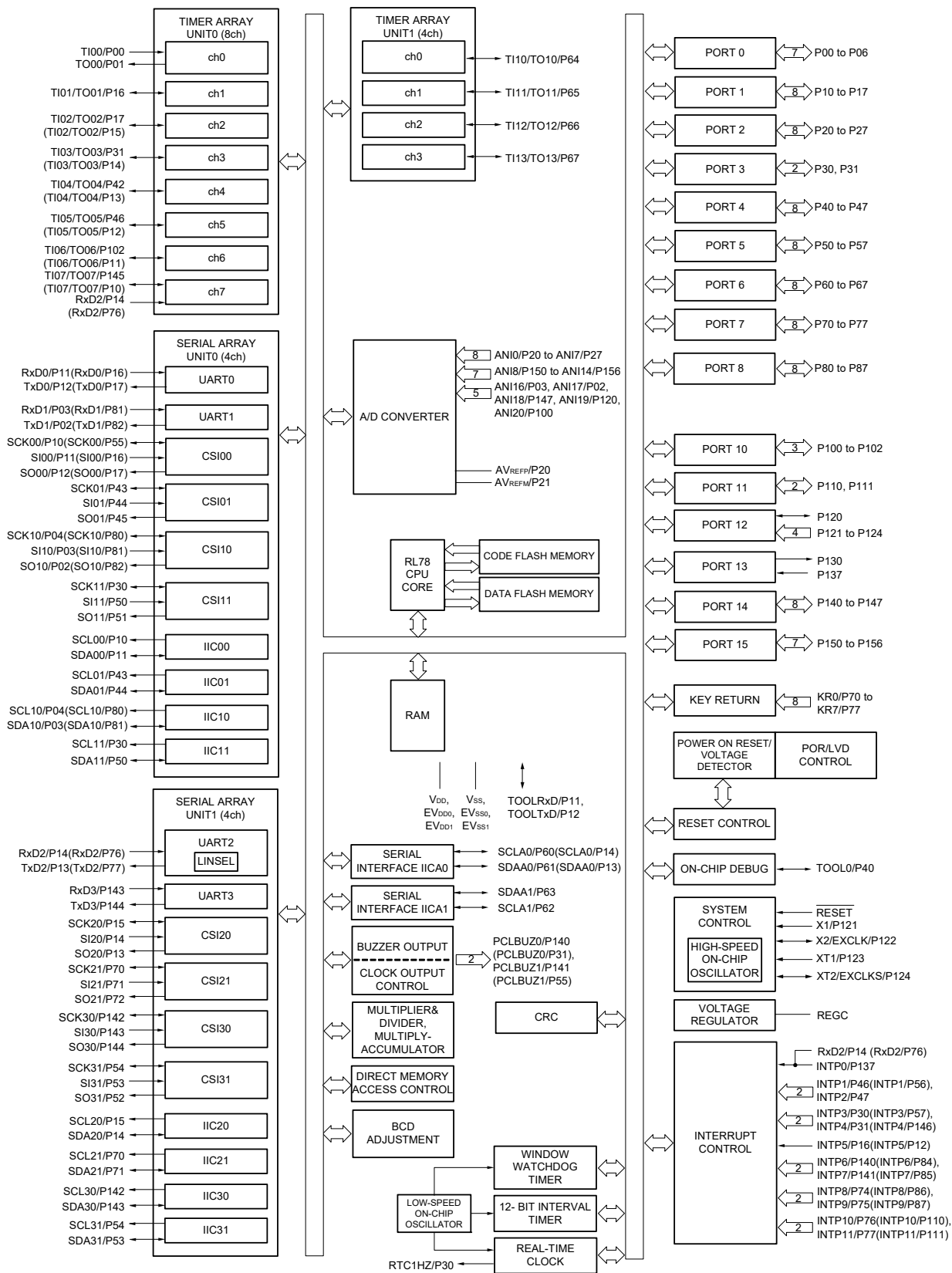

Remark Functions in parentheses in the above figure can be assigned via settings in the peripheral I/O redirection register (PIOR). Refer to **Figure 4-8 Format of Peripheral I/O Redirection Register (PIOR)**.

1.5.14 128-pin products

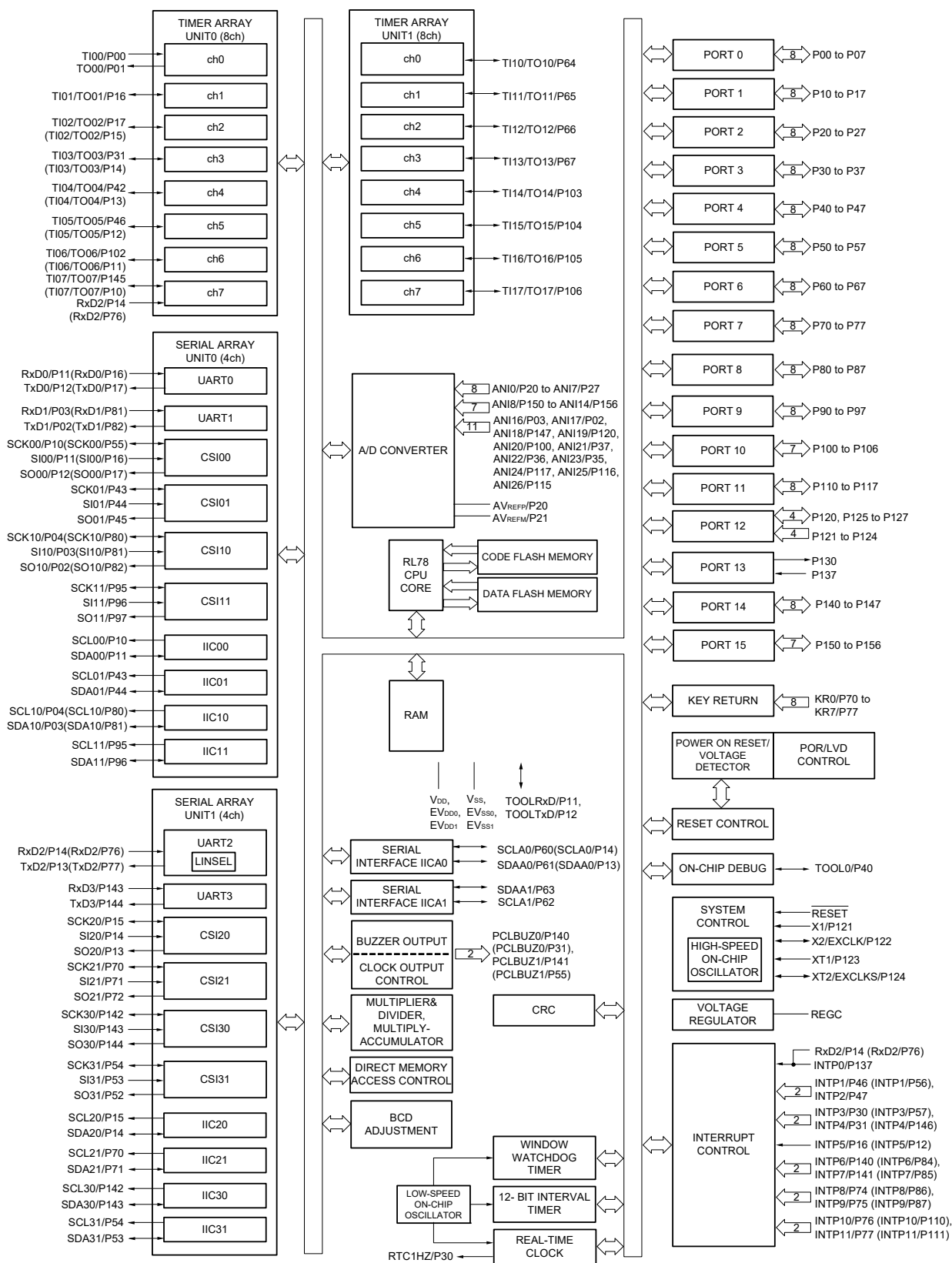

Remark Functions in parentheses in the above figure can be assigned via settings in the peripheral I/O redirection register (PIOR). Refer to **Figure 4-8 Format of Peripheral I/O Redirection Register (PIOR)**.

1.6 Outline of Functions

[20-pin, 24-pin, 25-pin, 30-pin, 32-pin, 36-pin products]

Caution This outline describes the functions at the time when Peripheral I/O redirection register (PIOR) is set to 00H.

(1/2)

Item		20-pin		24-pin		25-pin		30-pin		32-pin		36-pin	
		R5F1006X	R5F1016X	R5F1007X	R5F1017X	R5F1008X	R5F1018X	R5F100AX	R5F101AX	R5F100BX	R5F101BX	R5F100CX	R5F101CX
Code flash memory (KB)		16 to 64		16 to 64		16 to 64		16 to 128		16 to 128		16 to 128	
Data flash memory (KB)		4	–	4	–	4	–	4 to 8	–	4 to 8	–	4 to 8	–
RAM (KB)		2 to 4 ^{Note1}		2 to 4 ^{Note1}		2 to 4 ^{Note1}		2 to 12 ^{Note1}		2 to 12 ^{Note1}		2 to 12 ^{Note1}	
Address space		1 MB											
Main system clock	High-speed system clock	X1 (crystal/ceramic) oscillation, external main system clock input (EXCLK) HS (High-speed main) mode: 1 to 20 MHz (V _{DD} = 2.7 to 5.5 V), HS (High-speed main) mode: 1 to 16 MHz (V _{DD} = 2.4 to 5.5 V), LS (Low-speed main) mode: 1 to 8 MHz (V _{DD} = 1.8 to 5.5 V), LV (Low-voltage main) mode: 1 to 4 MHz (V _{DD} = 1.6 to 5.5 V)											
	High-speed on-chip oscillator	HS (High-speed main) mode: 1 to 32 MHz (V _{DD} = 2.7 to 5.5 V), HS (High-speed main) mode: 1 to 16 MHz (V _{DD} = 2.4 to 5.5 V), LS (Low-speed main) mode: 1 to 8 MHz (V _{DD} = 1.8 to 5.5 V), LV (Low-voltage main) mode: 1 to 4 MHz (V _{DD} = 1.6 to 5.5 V)											
Subsystem clock		–											
Low-speed on-chip oscillator		15 kHz (TYP.)											
General-purpose registers		(8-bit register × 8) × 4 banks											
Minimum instruction execution time		0.03125 μs (High-speed on-chip oscillator: f _{IH} = 32 MHz operation)											
		0.05 μs (High-speed system clock: f _{MX} = 20 MHz operation)											
Instruction set		<ul style="list-style-type: none"> • Data transfer (8/16 bits) • Adder and subtractor/logical operation (8/16 bits) • Multiplication (8 bits × 8 bits) • Rotate, barrel shift, and bit manipulation (Set, reset, test, and Boolean operation), etc. 											
I/O port	Total	16	20	21	26	28	32						
	CMOS I/O	13 (N-ch O.D. I/O [V _{DD} withstand voltage]: 5)	15 (N-ch O.D. I/O [V _{DD} withstand voltage]: 6)	15 (N-ch O.D. I/O [V _{DD} withstand voltage]: 6)	21 (N-ch O.D. I/O [V _{DD} withstand voltage]: 9)	22 (N-ch O.D. I/O [V _{DD} withstand voltage]: 9)	26 (N-ch O.D. I/O [V _{DD} withstand voltage]: 10)						
	CMOS input	3	3	3	3	3	3						
	CMOS output	–	–	1	–	–	–						
	N-ch O.D. I/O (withstand voltage: 6 V)	–	2	2	2	3	3						
Timer	16-bit timer	8 channels											
	Watchdog timer	1 channel											
	Real-time clock (RTC)	1 channel ^{Note 2}											
	12-bit interval timer (IT)	1 channel											
	Timer output	3 channels (PWM outputs: 2 ^{Note 3})	4 channels (PWM outputs: 3 ^{Note 3})	4 channels (PWM outputs: 3 ^{Note 3}), 8 channels (PWM outputs: 7 ^{Note 3}) ^{Note 4}									
	RTC output	–											

Notes 1. The flash library uses RAM in self-programming and rewriting of the data flash memory. The target products and start address of the RAM areas used by the flash library are shown below.

R5F100xD, R5F101xD (x = 6 to 8, A to C): Start address FF300H

R5F100xE, R5F101xE (x = 6 to 8, A to C): Start address FEF00H

For the RAM areas used by the flash library, see **Self RAM list of Flash Self-Programming Library for RL78 Family (R20UT2944)**.

- Notes**
- Only the constant-period interrupt function when the low-speed on-chip oscillator clock (f_{IL}) is selected
 - The number of PWM outputs varies depending on the setting of channels in use (the number of masters and slaves) (see **6.9.3 Operation as multiple PWM output function**).
 - When setting to $PIOR = 1$

(2/2)

Item	20-pin		24-pin		25-pin		30-pin		32-pin		36-pin		
	R5F1006X	R5F1016X	R5F1007X	R5F1017X	R5F1008X	R5F1018X	R5F100AX	R5F101AX	R5F100BX	R5F101BX	R5F100CX	R5F101CX	
Clock output/buzzer output	-		1		1		2		2		2		
	<ul style="list-style-type: none"> 2.44 kHz, 4.88 kHz, 9.76 kHz, 1.25 MHz, 2.5 MHz, 5 MHz, 10 MHz (Main system clock: $f_{MAIN} = 20$ MHz operation) 												
8/10-bit resolution A/D converter	6 channels		6 channels		6 channels		8 channels		8 channels		8 channels		
Serial interface	<p>[20-pin, 24-pin, 25-pin products]</p> <ul style="list-style-type: none"> Simplified SPI (CSI): 1 channel/simplified I²C: 1 channel/UART: 1 channel Simplified SPI (CSI): 1 channel/simplified I²C: 1 channel/UART: 1 channel <p>[30-pin, 32-pin products]</p> <ul style="list-style-type: none"> Simplified SPI (CSI): 1 channel/simplified I²C: 1 channel/UART: 1 channel Simplified SPI (CSI): 1 channel/simplified I²C: 1 channel/UART: 1 channel Simplified SPI (CSI): 1 channel/simplified I²C: 1 channel/UART (UART supporting LIN-bus): 1 channel <p>[36-pin products]</p> <ul style="list-style-type: none"> Simplified SPI (CSI): 1 channel/simplified I²C: 1 channel/UART: 1 channel Simplified SPI (CSI): 1 channel/simplified I²C: 1 channel/UART: 1 channel Simplified SPI (CSI): 2 channels/simplified I²C: 2 channels/UART (UART supporting LIN-bus): 1 channel 												
I ² C bus	-		1 channel		1 channel		1 channel		1 channel		1 channel		
Multiplier and divider/multiply-accumulator	<ul style="list-style-type: none"> 16 bits × 16 bits = 32 bits (Unsigned or signed) 32 bits ÷ 32 bits = 32 bits (Unsigned) 16 bits × 16 bits + 32 bits = 32 bits (Unsigned or signed) 												
DMA controller	2 channels												
Vectored interrupt sources	Internal	23		24		24		27		27		27	
	External	3		5		5		6		6		6	
Key interrupt	-												
Reset	<ul style="list-style-type: none"> Reset by RESET pin Internal reset by watchdog timer Internal reset by power-on-reset Internal reset by voltage detector Internal reset by illegal instruction execution ^{Note} Internal reset by RAM parity error Internal reset by illegal-memory access 												
Power-on-reset circuit	<ul style="list-style-type: none"> Power-on-reset: 1.51 V (TYP.) Power-down-reset: 1.50 V (TYP.) 												
Voltage detector	<ul style="list-style-type: none"> Rising edge : 1.67 V to 4.06 V (14 stages) Falling edge : 1.63 V to 3.98 V (14 stages) 												
On-chip debug function	Provided												
Power supply voltage	$V_{DD} = 1.6$ to 5.5 V ($T_A = -40$ to $+85^\circ\text{C}$) $V_{DD} = 2.4$ to 5.5 V ($T_A = -40$ to $+105^\circ\text{C}$)												
Operating ambient temperature	$T_A = 40$ to $+85^\circ\text{C}$ (A: Consumer applications, D: Industrial applications) $T_A = 40$ to $+105^\circ\text{C}$ (G: Industrial applications)												

Note The illegal instruction is generated when instruction code FFH is executed.

Reset by the illegal instruction execution not issued by emulation with the in-circuit emulator or on-chip debug emulator.

[40-pin, 44-pin, 48-pin, 52-pin, 64-pin products]

Caution This outline describes the functions at the time when Peripheral I/O redirection register (PIOR) is set to 00H.

(1/2)

Item		40-pin		44-pin		48-pin		52-pin		64-pin			
		R5F100EX	R5F101EX	R5F100FX	R5F101FX	R5F100GX	R5F101GX	R5F100JX	R5F101JX	R5F100LX	R5F101LX		
Code flash memory (KB)		16 to 192		16 to 512		16 to 512		32 to 512		32 to 512			
Data flash memory (KB)		4 to 8	–	4 to 8	–	4 to 8	–	4 to 8	–	4 to 8	–		
RAM (KB)		2 to 16 ^{Note1}		2 to 32 ^{Note1}		2 to 32 ^{Note1}		2 to 32 ^{Note1}		2 to 32 ^{Note1}			
Address space		1 MB											
Main system clock	High-speed system clock	X1 (crystal/ceramic) oscillation, external main system clock input (EXCLK) HS (High-speed main) mode: 1 to 20 MHz (V _{DD} = 2.7 to 5.5 V), HS (High-speed main) mode: 1 to 16 MHz (V _{DD} = 2.4 to 5.5 V), LS (Low-speed main) mode: 1 to 8 MHz (V _{DD} = 1.8 to 5.5 V), LV (Low-voltage main) mode: 1 to 4 MHz (V _{DD} = 1.6 to 5.5 V)											
	High-speed on-chip oscillator	HS (High-speed main) mode: 1 to 32 MHz (V _{DD} = 2.7 to 5.5 V), HS (High-speed main) mode: 1 to 16 MHz (V _{DD} = 2.4 to 5.5 V), LS (Low-speed main) mode: 1 to 8 MHz (V _{DD} = 1.8 to 5.5 V), LV (Low-voltage main) mode: 1 to 4 MHz (V _{DD} = 1.6 to 5.5 V)											
Subsystem clock		XT1 (crystal) oscillation, external subsystem clock input (EXCLKS) 32.768 kHz											
Low-speed on-chip oscillator		15 kHz (TYP.)											
General-purpose registers		(8-bit register × 8) × 4 banks											
Minimum instruction execution time		0.03125 μs (High-speed on-chip oscillator: f _{IH} = 32 MHz operation)											
		0.05 μs (High-speed system clock: f _{MX} = 20 MHz operation)											
		30.5 μs (Subsystem clock: f _{SUB} = 32.768 kHz operation)											
Instruction set		<ul style="list-style-type: none"> • Data transfer (8/16 bits) • Adder and subtractor/logical operation (8/16 bits) • Multiplication (8 bits × 8 bits) • Rotate, barrel shift, and bit manipulation (Set, reset, test, and Boolean operation), etc. 											
I/O port	Total	36		40		44		48		58			
	CMOS I/O	28 (N-ch O.D. I/O [V _{DD} withstand voltage]: 10)		31 (N-ch O.D. I/O [V _{DD} withstand voltage]: 10)		34 (N-ch O.D. I/O [V _{DD} withstand voltage]: 11)		38 (N-ch O.D. I/O [V _{DD} withstand voltage]: 13)		48 (N-ch O.D. I/O [V _{DD} withstand voltage]: 15)			
	CMOS input	5		5		5		5		5			
	CMOS output	–		–		1		1		1			
	N-ch O.D. I/O (withstand voltage: 6 V)	3		4		4		4		4			
Timer	16-bit timer	8 channels											
	Watchdog timer	1 channel											
	Real-time clock (RTC)	1 channel											
	12-bit interval timer (IT)	1 channel											
	Timer output	4 channels (PWM outputs: 3 ^{Note2}), 8 channels (PWM outputs: 7 ^{Note2}) ^{Note3}		5 channels (PWM outputs: 4 ^{Note2}), 8 channels (PWM outputs: 7 ^{Note2}) ^{Note3}						8 channels (PWM outputs: 7 ^{Note2})			
	RTC output	1 channel • 1 Hz (subsystem clock: f _{SUB} = 32.768 kHz)											

Notes 1. The flash library uses RAM in self-programming and rewriting of the data flash memory. The target products and start address of the RAM areas used by the flash library are shown below.
 R5F100xD, R5F101xD (x = E to G, J, L): Start address FF300H
 R5F100xE, R5F101xE (x = E to G, J, L): Start address FEF00H
 R5F100xJ, R5F101xJ (x = F, G, J, L): Start address FAF00H
 R5F100xL, R5F101xL (x = F, G, J, L): Start address F7F00H
 For the RAM areas used by the flash library, see **Self RAM list of Flash Self-Programming Library for RL78 Family (R20UT2944)**.

- Notes 2.** The number of PWM outputs varies depending on the setting of channels in use (the number of masters and slaves) (see **6.9.3 Operation as multiple PWM output function**).
- 3.** When setting to PIOR = 1

(2/2)

Item	40-pin		44-pin		48-pin		52-pin		64-pin		
	R5F100EX	R5F101EX	R5F100FX	R5F101FX	R5F100GX	R5F101GX	R5F100JX	R5F101JX	R5F100LX	R5F101LX	
Clock output/buzzer output	2		2		2		2		2		
	<ul style="list-style-type: none"> • 2.44 kHz, 4.88 kHz, 9.76 kHz, 1.25 MHz, 2.5 MHz, 5 MHz, 10 MHz (Main system clock: $f_{MAIN} = 20$ MHz operation) • 256 Hz, 512 Hz, 1.024 kHz, 2.048 kHz, 4.096 kHz, 8.192 kHz, 16.384 kHz, 32.768 kHz (Subsystem clock: $f_{SUB} = 32.768$ kHz operation) 										
8/10-bit resolution A/D converter	9 channels		10 channels		10 channels		12 channels		12 channels		
Serial interface	[40-pin, 44-pin products] <ul style="list-style-type: none"> • Simplified SPI (CSI): 1 channel/simplified I²C: 1 channel/UART: 1 channel • Simplified SPI (CSI): 1 channel/simplified I²C: 1 channel/UART: 1 channel • Simplified SPI (CSI): 2 channels/simplified I²C: 2 channels/UART (UART supporting LIN-bus): 1 channel [48-pin, 52-pin products] <ul style="list-style-type: none"> • Simplified SPI (CSI): 2 channels/simplified I²C: 2 channels/UART: 1 channel • Simplified SPI (CSI): 1 channel/simplified I²C: 1 channel/UART: 1 channel • Simplified SPI (CSI): 2 channels/simplified I²C: 2 channels/UART (UART supporting LIN-bus): 1 channel [64-pin products] <ul style="list-style-type: none"> • Simplified SPI (CSI): 2 channels/simplified I²C: 2 channels/UART: 1 channel • Simplified SPI (CSI): 2 channels/simplified I²C: 2 channels/UART: 1 channel • Simplified SPI (CSI): 2 channels/simplified I²C: 2 channels/UART (UART supporting LIN-bus): 1 channel 										
	I ² C bus	1 channel		1 channel		1 channel		1 channel		1 channel	
Multiplier and divider/multiply-accumulator	<ul style="list-style-type: none"> • 16 bits × 16 bits = 32 bits (Unsigned or signed) • 32 bits ÷ 32 bits = 32 bits (Unsigned) • 16 bits × 16 bits + 32 bits = 32 bits (Unsigned or signed) 										
DMA controller	2 channels										
Vectored interrupt sources	Internal	27		27		27		27		27	
	External	7		7		10		12		13	
Key interrupt	4		4		6		8		8		
Reset	<ul style="list-style-type: none"> • Reset by RESET pin • Internal reset by watchdog timer • Internal reset by power-on-reset • Internal reset by voltage detector • Internal reset by illegal instruction execution ^{Note} • Internal reset by RAM parity error • Internal reset by illegal-memory access 										
Power-on-reset circuit	<ul style="list-style-type: none"> • Power-on-reset: 1.51 V (TYP.) • Power-down-reset: 1.50 V (TYP.) 										
Voltage detector	<ul style="list-style-type: none"> • Rising edge : 1.67 V to 4.06 V (14 stages) • Falling edge : 1.63 V to 3.98 V (14 stages) 										
On-chip debug function	Provided										
Power supply voltage	$V_{DD} = 1.6$ to 5.5 V ($T_A = -40$ to $+85^\circ\text{C}$) $V_{DD} = 2.4$ to 5.5 V ($T_A = -40$ to $+105^\circ\text{C}$)										
Operating ambient temperature	$T_A = 40$ to $+85^\circ\text{C}$ (A: Consumer applications, D: Industrial applications) $T_A = 40$ to $+105^\circ\text{C}$ (G: Industrial applications)										

Note The illegal instruction is generated when instruction code FFH is executed.
 Reset by the illegal instruction execution not issued by emulation with the in-circuit emulator or on-chip debug emulator.

[80-pin, 100-pin, 128-pin products]

Caution This outline describes the functions at the time when Peripheral I/O redirection register (PIOR) is set to 00H.

(1/2)

Item		80-pin		100-pin		128-pin	
		R5F100Mx	R5F101Mx	R5F100Px	R5F101Px	R5F100Sx	R5F101Sx
Code flash memory (KB)		96 to 512		96 to 512		192 to 512	
Data flash memory (KB)		8	–	8	–	8	–
RAM (KB)		8 to 32 ^{Note 1}		8 to 32 ^{Note 1}		16 to 32 ^{Note 1}	
Address space		1 MB					
Main system clock	High-speed system clock	X1 (crystal/ceramic) oscillation, external main system clock input (EXCLK) HS (High-speed main) mode: 1 to 20 MHz (V _{DD} = 2.7 to 5.5 V), HS (High-speed main) mode: 1 to 16 MHz (V _{DD} = 2.4 to 5.5 V), LS (Low-speed main) mode: 1 to 8 MHz (V _{DD} = 1.8 to 5.5 V), LV (Low-voltage main) mode: 1 to 4 MHz (V _{DD} = 1.6 to 5.5 V)					
	High-speed on-chip oscillator	HS (High-speed main) mode: 1 to 32 MHz (V _{DD} = 2.7 to 5.5 V), HS (High-speed main) mode: 1 to 16 MHz (V _{DD} = 2.4 to 5.5 V), LS (Low-speed main) mode: 1 to 8 MHz (V _{DD} = 1.8 to 5.5 V), LV (Low-voltage main) mode: 1 to 4 MHz (V _{DD} = 1.6 to 5.5 V)					
Subsystem clock		XT1 (crystal) oscillation, external subsystem clock input (EXCLKS) 32.768 kHz					
Low-speed on-chip oscillator		15 kHz (TYP.)					
General-purpose register		(8-bit register × 8) × 4 banks					
Minimum instruction execution time		0.03125 μs (High-speed on-chip oscillator: f _{IH} = 32 MHz operation)					
		0.05 μs (High-speed system clock: f _{MX} = 20 MHz operation)					
		30.5 μs (Subsystem clock: f _{SUB} = 32.768 kHz operation)					
Instruction set		<ul style="list-style-type: none"> • Data transfer (8/16 bits) • Adder and subtractor/logical operation (8/16 bits) • Multiplication (8 bits × 8 bits) • Rotate, barrel shift, and bit manipulation (Set, reset, test, and Boolean operation), etc. 					
I/O port	Total	74		92		120	
	CMOS I/O	64 (N-ch O.D. I/O [EV _{DD} withstand voltage]: 21)		82 (N-ch O.D. I/O [EV _{DD} withstand voltage]: 24)		110 (N-ch O.D. I/O [EV _{DD} withstand voltage]: 25)	
	CMOS input	5		5		5	
	CMOS output	1		1		1	
	N-ch O.D. I/O (withstand voltage: 6 V)	4		4		4	
Timer	16-bit timer	12 channels		12 channels		16 channels	
	Watchdog timer	1 channel		1 channel		1 channel	
	Real-time clock (RTC)	1 channel		1 channel		1 channel	
	12-bit interval timer (IT)	1 channel		1 channel		1 channel	
	Timer output	12 channels (PWM outputs: 10 ^{Note 2})		12 channels (PWM outputs: 10 ^{Note 2})		16 channels (PWM outputs: 14 ^{Note 2})	
	RTC output	1 channel • 1 Hz (subsystem clock: f _{SUB} = 32.768 kHz)					

Notes 1. The flash library uses RAM in self-programming and rewriting of the data flash memory. The target products and start address of the RAM areas used by the flash library are shown below.
 R5F100xJ, R5F101xJ (x = M, P): Start address FAF00H
 R5F100xL, R5F101xL (x = M, P, S): Start address F7F00H
 For the RAM areas used by the flash library, see **Self RAM list of Flash Self-Programming Library for RL78 Family (R20UT2944)**.

Notes 2. The number of PWM outputs varies depending on the setting of channels in use (the number of masters and slaves) (see **6.9.3 Operation as multiple PWM output function**).

(2/2)

Item	80-pin		100-pin		128-pin	
	R5F100Mx	R5F101Mx	R5F100Px	R5F101Px	R5F100Sx	R5F101Sx
Clock output/buzzer output	2		2		2	
	<ul style="list-style-type: none"> 2.44 kHz, 4.88 kHz, 9.76 kHz, 1.25 MHz, 2.5 MHz, 5 MHz, 10 MHz (Main system clock: $f_{MAIN} = 20$ MHz operation) 256 Hz, 512 Hz, 1.024 kHz, 2.048 kHz, 4.096 kHz, 8.192 kHz, 16.384 kHz, 32.768 kHz (Subsystem clock: $f_{SUB} = 32.768$ kHz operation) 					
8/10-bit resolution A/D converter	17 channels		20 channels		26 channels	
Serial interface	[80-pin, 100-pin, 128-pin products]					
	<ul style="list-style-type: none"> Simplified SPI (CSI): 2 channels/simplified I²C: 2 channels/UART: 1 channel Simplified SPI (CSI): 2 channels/simplified I²C: 2 channels/UART: 1 channel Simplified SPI (CSI): 2 channels/simplified I²C: 2 channels/UART (UART supporting LIN-bus): 1 channel Simplified SPI (CSI): 2 channels/simplified I²C: 2 channels/UART: 1 channel 					
I ² C bus	2 channels		2 channels		2 channels	
Multiplier and divider/multiply-accumulator	<ul style="list-style-type: none"> 16 bits × 16 bits = 32 bits (Unsigned or signed) 32 bits ÷ 32 bits = 32 bits (Unsigned) 16 bits × 16 bits + 32 bits = 32 bits (Unsigned or signed) 					
DMA controller	4 channels					
Vectored interrupt sources	Internal	37		37		41
	External	13		13		13
Key interrupt	8		8		8	
Reset	<ul style="list-style-type: none"> Reset by \overline{RESET} pin Internal reset by watchdog timer Internal reset by power-on-reset Internal reset by voltage detector Internal reset by illegal instruction execution ^{Note} Internal reset by RAM parity error Internal reset by illegal-memory access 					
Power-on-reset circuit	<ul style="list-style-type: none"> Power-on-reset: 1.51 V (TYP.) Power-down-reset: 1.50 V (TYP.) 					
Voltage detector	<ul style="list-style-type: none"> Rising edge : 1.67 V to 4.06 V (14 stages) Falling edge : 1.63 V to 3.98 V (14 stages) 					
On-chip debug function	Provided					
Power supply voltage	$V_{DD} = 1.6$ to 5.5 V ($T_A = -40$ to $+85^\circ\text{C}$) $V_{DD} = 2.4$ to 5.5 V ($T_A = -40$ to $+105^\circ\text{C}$)					
Operating ambient temperature	$T_A = 40$ to $+85^\circ\text{C}$ (A: Consumer applications, D: Industrial applications) $T_A = 40$ to $+105^\circ\text{C}$ (G: Industrial applications)					

Note The illegal instruction is generated when instruction code FFH is executed.
 Reset by the illegal instruction execution not issued by emulation with the in-circuit emulator or on-chip debug emulator.

CHAPTER 2 PIN FUNCTIONS

2.1 Port Function

Pin I/O buffer power supplies depend on the product. The relationship between these power supplies and the pins is shown below.

Table 2-1. Pin I/O Buffer Power Supplies

(1) 20-pin, 24-pin, 25-pin, 30-pin, 32-pin, 36-pin, 40-pin, 44-pin, 48-pin, 52-pin products

Power Supply	Corresponding Pins
V _{DD}	All pins

(2) 64-pin products

Power Supply	Corresponding Pins
EV _{DD0}	Port pins other than P20 to P27, P121 to P124, and P137
V _{DD}	<ul style="list-style-type: none"> • P20 to P27, P121 to P124, and P137 • $\overline{\text{RESET}}$, REGC

(3) 80-pin products

Power Supply	Corresponding Pins
EV _{DD0}	Port pins other than P20 to P27, P121 to P124, P137, and P150 to P153
V _{DD}	<ul style="list-style-type: none"> • P20 to P27, P121 to P124, P137, and P150 to P153 • $\overline{\text{RESET}}$, REGC

(4) 100-pin products

Power Supply	Corresponding Pins
EV _{DD0} , EV _{DD1}	Port pins other than P20 to P27, P121 to P124, P137, and P150 to P156
V _{DD}	<ul style="list-style-type: none"> • P20 to P27, P121 to P124, P137, and P150 to P156 • $\overline{\text{RESET}}$, REGC

(5) 128-pin products

Power Supply	Corresponding Pins
EV _{DD0} , EV _{DD1}	Port pins other than P20 to P27, P121 to P124, P137, and P150 to P156
V _{DD}	<ul style="list-style-type: none"> • P20 to P27, P121 to P124, P137, and P150 to P156 • $\overline{\text{RESET}}$, REGC

Caution EV_{DD0} and EV_{DD1} should have the same potential.

Set in each port I/O, buffer, pull-up resistor is also valid for alternate functions.

2.1.1 20-pin products

(1/2)

Function Name	Pin Type	I/O	After Reset Release	Alternate Function	Function																																																		
P00	7-3-2	I/O	Analog input port	ANI17/TI00/TxD1	Port 0. 2-bit I/O port. Input/output can be specified in 1-bit units. Use of an on-chip pull-up resistor can be specified by a software setting at input port. Input of P01 can be set to TTL input buffer. Output of P00 can be set to N-ch open-drain output (V_{DD} tolerance). P00 and P01 can be set to analog input Note 1 .																																																		
P01	8-3-1			ANI16/TO00/RxD1		P10	8-1-2	I/O	Input port	SCK00/SCL00	Port 1. 5-bit I/O port. Input/output can be specified in 1-bit units. Use of an on-chip pull-up resistor can be specified by a software setting at input port. Input of P10, P11, P16, and P17 can be set to TTL input buffer. Output of P10 to P12 and P17 can be set to N-ch open-drain output (V_{DD} tolerance).	P11	SI00/RxD0/ TOOLRxD/SDA00	P12	7-1-2	SO00/TxD0/ TOOLTxD	P16	8-1-1	TI01/TO01/INTP5/ SO11	P17	8-1-2	TI02/TO02/SI11/ SDA11	P20	4-3-1	I/O	Analog input port	ANI0/AV _{REFP}	Port 2. 3-bit I/O port. Input/output can be specified in 1-bit units. Can be set to analog input Note 2 .	P21	ANI1/AV _{REFM}	P22	ANI2	P30	7-1-1	I/O	Input port	INTP3/ SCK11/SCL11	Port 3. 1-bit I/O port. Input/output can be specified in 1-bit units. Use of an on-chip pull-up resistor can be specified by a software setting at input port.	P40	7-1-1	I/O	Input port	TOOL0	Port 4. 1-bit I/O port. Input/output can be specified in 1-bit units. Use of an on-chip pull-up resistor can be specified by a software setting at input port.	P121	2-2-1	Input	Input port	X1	Port 12. 2-bit input only port.	P122	X2/EXCLK	P137	2-1-2	Input
P10	8-1-2	I/O	Input port	SCK00/SCL00	Port 1. 5-bit I/O port. Input/output can be specified in 1-bit units. Use of an on-chip pull-up resistor can be specified by a software setting at input port. Input of P10, P11, P16, and P17 can be set to TTL input buffer. Output of P10 to P12 and P17 can be set to N-ch open-drain output (V_{DD} tolerance).																																																		
P11				SI00/RxD0/ TOOLRxD/SDA00																																																			
P12	7-1-2			SO00/TxD0/ TOOLTxD																																																			
P16	8-1-1			TI01/TO01/INTP5/ SO11																																																			
P17	8-1-2			TI02/TO02/SI11/ SDA11																																																			
P20	4-3-1	I/O	Analog input port	ANI0/AV _{REFP}	Port 2. 3-bit I/O port. Input/output can be specified in 1-bit units. Can be set to analog input Note 2 .																																																		
P21				ANI1/AV _{REFM}																																																			
P22				ANI2																																																			
P30	7-1-1	I/O	Input port	INTP3/ SCK11/SCL11	Port 3. 1-bit I/O port. Input/output can be specified in 1-bit units. Use of an on-chip pull-up resistor can be specified by a software setting at input port.																																																		
P40	7-1-1	I/O	Input port	TOOL0	Port 4. 1-bit I/O port. Input/output can be specified in 1-bit units. Use of an on-chip pull-up resistor can be specified by a software setting at input port.																																																		
P121	2-2-1	Input	Input port	X1	Port 12. 2-bit input only port.																																																		
P122				X2/EXCLK																																																			
P137	2-1-2	Input	Input port	INTP0	Port 13 1bit input only port.																																																		

Notes 1. Digital or analog for each pin can be selected with the port mode control register x (PMCx) (can be set in 1-bit unit).

2. Digital or analog for each pin can be selected with the A/D port configuration register (ADPC).

(2/2)

Function Name	Pin Type	I/O	After Reset Release	Alternate Function	Function
P147	7-3-1	I/O	Analog input port	ANI18	Port 14. 1-bit I/O port. Input/output can be specified in 1-bit units. Use of an on-chip pull-up resistor can be specified by a software setting at input port. P147 can be set to analog input Note .
$\overline{\text{RESET}}$	2-1-1	Input	—	—	Input only pin for external reset When external reset is not used, connect this pin to V _{DD} directly or via a resistor.

Note Digital or analog for each pin can be selected with the port mode control register x (PMCx) (can be set in 1-bit unit).

2.1.2 24-pin products

(1/2)

Function Name	Pin Type	I/O	After Reset Release	Alternate Function	Function																																																				
P00	7-3-2	I/O	Analog input port	ANI17/TI00/TxD1	Port 0. 2-bit I/O port. Input/output can be specified in 1-bit units. Use of an on-chip pull-up resistor can be specified by a software setting at input port. Input of P01 can be set to TTL input buffer. Output of P00 can be set to N-ch open-drain output (V_{DD} tolerance). P00 and P01 can be set to analog input Note 1 .																																																				
P01	8-3-1			ANI16/TO00/RxD1		P10	8-1-2	I/O	Input port	SCK00/SCL00	Port 1. 5-bit I/O port. Input/output can be specified in 1-bit units. Use of an on-chip pull-up resistor can be specified by a software setting at input port. Input of P10, P11, P16, and P17 can be set to TTL input buffer. Output of P10 to P12, and P17 can be set to N-ch open-drain output (V_{DD} tolerance).	P11	SI00/RxD0/ TOOLRxD/SDA00	P12	7-1-2	SO00/TxD0/ TOOLTxD	P16	8-1-1	TI01/TO01/INTP5	P17	8-1-2	TI02/TO02/SO11	P20	4-3-1	I/O	Analog input port	ANI0/AV _{REFP}	Port 2. 3-bit I/O port. Input/output can be specified in 1-bit units. Can be set to analog input Note 2 .	P21	ANI1/AV _{REFM}	P22	ANI2	P30	7-1-1	I/O	Input port	INTP3/ SCK11/SCL11	Port 3. 2-bit I/O port. Input/output can be specified in 1-bit units. Use of an on-chip pull-up resistor can be specified by a software setting at input port.	P31	TI03/TO03/INTP4/ PCLBUZ0	P40	7-1-1	I/O	Input port	TOOL0	Port 4. 1-bit I/O port. Input/output can be specified in 1-bit units. Use of an on-chip pull-up resistor can be specified by a software setting at input port.	P50	7-1-2	I/O	Input port	INTP1/SI11/SDA11	Port 5. 1-bit I/O port. Output of P50 can be set to N-ch open-drain output (V_{DD} tolerance). Input/output can be specified in 1-bit units. Use of an on-chip pull-up resistor can be specified by a software setting at input port.	P60	12-1-1	I/O	Input port	SCLA0
P10	8-1-2	I/O	Input port	SCK00/SCL00	Port 1. 5-bit I/O port. Input/output can be specified in 1-bit units. Use of an on-chip pull-up resistor can be specified by a software setting at input port. Input of P10, P11, P16, and P17 can be set to TTL input buffer. Output of P10 to P12, and P17 can be set to N-ch open-drain output (V_{DD} tolerance).																																																				
P11				SI00/RxD0/ TOOLRxD/SDA00																																																					
P12	7-1-2			SO00/TxD0/ TOOLTxD																																																					
P16	8-1-1			TI01/TO01/INTP5																																																					
P17	8-1-2			TI02/TO02/SO11																																																					
P20	4-3-1	I/O	Analog input port	ANI0/AV _{REFP}	Port 2. 3-bit I/O port. Input/output can be specified in 1-bit units. Can be set to analog input Note 2 .																																																				
P21				ANI1/AV _{REFM}																																																					
P22				ANI2																																																					
P30	7-1-1	I/O	Input port	INTP3/ SCK11/SCL11	Port 3. 2-bit I/O port. Input/output can be specified in 1-bit units. Use of an on-chip pull-up resistor can be specified by a software setting at input port.																																																				
P31				TI03/TO03/INTP4/ PCLBUZ0																																																					
P40	7-1-1	I/O	Input port	TOOL0	Port 4. 1-bit I/O port. Input/output can be specified in 1-bit units. Use of an on-chip pull-up resistor can be specified by a software setting at input port.																																																				
P50	7-1-2	I/O	Input port	INTP1/SI11/SDA11	Port 5. 1-bit I/O port. Output of P50 can be set to N-ch open-drain output (V_{DD} tolerance). Input/output can be specified in 1-bit units. Use of an on-chip pull-up resistor can be specified by a software setting at input port.																																																				
P60	12-1-1	I/O	Input port	SCLA0	Port 6. 2-bit I/O port. Input/output can be specified in 1-bit units. Output of P60 and P61 can be set to N-ch open-drain output (6 V tolerance).																																																				
P61				SDAA0																																																					

Notes 1. Digital or analog for each pin can be selected with the port mode control register x (PMCx) (can be set in 1-bit unit).

2. Digital or analog for each pin can be selected with the A/D port configuration register (ADPC).

Remark Functions in parentheses in the above figure can be assigned via settings in the peripheral I/O redirection register (PIOR). Refer to **Figure 4-8 Format of Peripheral I/O Redirection Register (PIOR)**.

(2/2)

Function Name	Pin Type	I/O	After Reset Release	Alternate Function	Function
P121	2-2-1	Input	Input port	X1	Port 12. 2-bit input only port.
P122				X2/EXCLK	
P137	2-1-2	Input	Input port	INTP0	Port 13 1bit input only port.
P147	7-3-1	I/O	Analog input port	ANI18	Port 14. 1-bit I/O port. Input/output can be specified in 1-bit units. Use of an on-chip pull-up resistor can be specified by a software setting at input port. P147 can be set to analog input Note .
$\overline{\text{RESET}}$	2-1-1	Input	—	—	Input only pin for external reset When external reset is not used, connect this pin to V _{DD} directly or via a resistor.

Note Digital or analog for each pin can be selected with the port mode control register x (PMCx) (can be set in 1-bit unit).

2.1.3 25-pin products

(1/2)

Function Name	Pin Type	I/O	After Reset Release	Alternate Function	Function																																																				
P00	7-3-2	I/O	Analog input port	ANI17/TI00/TxD1	Port 0. 2-bit I/O port. Input/output can be specified in 1-bit units. Use of an on-chip pull-up resistor can be specified by a software setting at input port. Input of P01 can be set to TTL input buffer. Output of P00 can be set to N-ch open-drain output (V_{DD} tolerance). P00 and P01 can be set to analog input Note 1 .																																																				
P01	8-3-1			ANI16/TO00/RxD1		P10	8-1-2	I/O	Input port	SCK00/SCL00	Port 1. 5-bit I/O port. Input/output can be specified in 1-bit units. Use of an on-chip pull-up resistor can be specified by a software setting at input port. Input of P10, P11, P16, and P17 can be set to TTL input buffer. Output of P10 to P12 and P17 can be set to N-ch open-drain output (V_{DD} tolerance).	P11	SI00/RxD0/ TOOLRxD/SDA00	P12	7-1-2	SO00/TxD0/ TOOLTxD	P16	8-1-1	TI01/TO01/INTP5	P17	8-1-2	TI02/TO02/SO11	P20	4-3-1	I/O	Analog input port	ANI0/AV _{REFP}	Port 2. 3-bit I/O port. Input/output can be specified in 1-bit units. Can be set to analog input Note 2 .	P21	ANI1/AV _{REFM}	P22	ANI2	P30	7-1-1	I/O	Input port	INTP3/ SCK11/SCL11	Port 3. 2-bit I/O port. Input/output can be specified in 1-bit units. Use of an on-chip pull-up resistor can be specified by a software setting at input port.	P31	TI03/TO03/INTP4/ PCLBUZ0	P40	7-1-1	I/O	Input port	TOOL0	Port 4. 1-bit I/O port. Input/output can be specified in 1-bit units. Use of an on-chip pull-up resistor can be specified by a software setting at input port.	P50	7-1-2	I/O	Input port	INTP1/SI11/SDA11	Port 5. 1-bit I/O port. Input/output can be specified in 1-bit units. Use of an on-chip pull-up resistor can be specified by a software setting at input port. Output of P50 can be set to N-ch open-drain output (V_{DD} tolerance).	P60	12-1-1	I/O	Input port	SCLA0
P10	8-1-2	I/O	Input port	SCK00/SCL00	Port 1. 5-bit I/O port. Input/output can be specified in 1-bit units. Use of an on-chip pull-up resistor can be specified by a software setting at input port. Input of P10, P11, P16, and P17 can be set to TTL input buffer. Output of P10 to P12 and P17 can be set to N-ch open-drain output (V_{DD} tolerance).																																																				
P11				SI00/RxD0/ TOOLRxD/SDA00																																																					
P12	7-1-2			SO00/TxD0/ TOOLTxD																																																					
P16	8-1-1			TI01/TO01/INTP5																																																					
P17	8-1-2			TI02/TO02/SO11																																																					
P20	4-3-1	I/O	Analog input port	ANI0/AV _{REFP}	Port 2. 3-bit I/O port. Input/output can be specified in 1-bit units. Can be set to analog input Note 2 .																																																				
P21				ANI1/AV _{REFM}																																																					
P22				ANI2																																																					
P30	7-1-1	I/O	Input port	INTP3/ SCK11/SCL11	Port 3. 2-bit I/O port. Input/output can be specified in 1-bit units. Use of an on-chip pull-up resistor can be specified by a software setting at input port.																																																				
P31				TI03/TO03/INTP4/ PCLBUZ0																																																					
P40	7-1-1	I/O	Input port	TOOL0	Port 4. 1-bit I/O port. Input/output can be specified in 1-bit units. Use of an on-chip pull-up resistor can be specified by a software setting at input port.																																																				
P50	7-1-2	I/O	Input port	INTP1/SI11/SDA11	Port 5. 1-bit I/O port. Input/output can be specified in 1-bit units. Use of an on-chip pull-up resistor can be specified by a software setting at input port. Output of P50 can be set to N-ch open-drain output (V_{DD} tolerance).																																																				
P60	12-1-1	I/O	Input port	SCLA0	Port 6. 2-bit I/O port. Input/output can be specified in 1-bit units. Output of P60 and P61 can be set to N-ch open-drain output (6 V tolerance).																																																				
P61				SDAA0																																																					

Notes 1. Digital or analog for each pin can be selected with the port mode control register x (PMCx) (can be set in 1-bit unit).

2. Digital or analog for each pin can be selected with the A/D port configuration register (ADPC).

Remark Functions in parentheses in the above figure can be assigned via settings in the peripheral I/O redirection register (PIOR). Refer to **Figure 4-8 Format of Peripheral I/O Redirection Register (PIOR)**.

(2/2)

Function Name	Pin Type	I/O	After Reset Release	Alternate Function	Function
P121	2-2-1	Input	Input port	X1	Port 12. 2-bit input only port.
P122				X2/EXCLK	
P130	1-1-1	Output	Output port	—	Port 13 1-bit output only port and 1-bit input only port.
P137	2-1-2	Input	Input port	INTP0	
P147	7-3-1	I/O	Analog input port	ANI18	Port 14. 1-bit I/O port. Input/output can be specified in 1-bit units. Use of an on-chip pull-up resistor can be specified by a software setting at input port. P147 can be set to analog input Note .
$\overline{\text{RESET}}$	2-1-1	Input	—	—	Input only pin for external reset When external reset is not used, connect this pin to V_{DD} directly or via a resistor.

Note Digital or analog for each pin can be selected with the port mode control register x (PMCx) (can be set in 1-bit unit).

2.1.4 30-pin products

(1/2)

Function Name	Pin Type	I/O	After Reset Release	Alternate Function	Function																																																						
P00	7-3-2	I/O	Analog input port	ANI17/TI00/TxD1	Port 0. 2-bit I/O port. Input/output can be specified in 1-bit units. Use of an on-chip pull-up resistor can be specified by a software setting at input port. Input of P01 can be set to TTL input buffer. Output of P00 can be set to N-ch open-drain output (V_{DD} tolerance). P00 and P01 can be set to analog input Note 1 .																																																						
P01	8-3-1			ANI16/TO00/RxD1		P10	8-1-2	I/O	Input port	SCK00/SCL00/(TI07)/(TO07)	Port 1. 8-bit I/O port. Input/output can be specified in 1-bit units. Use of an on-chip pull-up resistor can be specified by a software setting at input port. Input of P10, P11, and P13 to P17 can be set to TTL input buffer. Output of P10 to P15, and P17 can be set to N-ch open-drain output (V_{DD} tolerance).	P11	8-1-2	SI00/RxD0/TOOLRxD/SDA00/(TI06)/(TO06)	P12	7-1-2	SO00/TxD0/TOOLTxD/(TI05)/(TO05)	P13	8-1-2	TxD2/SO20/(SDAA0)/(TI04)/(TO04)	P14	8-1-2	RxD2/SI20/SDA20/(SCLA0)/(TI03)/(TO03)	P15	8-1-2	PCLBUZ1/SCK20/SCL20/(TI02)/(TO02)	P16	8-1-1	TI01/TO01/INTP5/(RxD0)	P17	8-1-2	TI02/TO02/(TxD0)	P20	4-3-1	I/O	Analog input port	ANI0/ AV_{REFP}	Port 2. 4-bit I/O port. Input/output can be specified in 1-bit units. Can be set to analog input Note 2 .	P21	4-3-1	ANI1/ AV_{REFM}	P22	4-3-1	ANI2	P23	4-3-1	ANI3	P30	7-1-1	I/O	Input port	INTP3/SCK11/SCL11	Port 3. 2-bit I/O port. Input/output can be specified in 1-bit units. Use of an on-chip pull-up resistor can be specified by a software setting at input port.	P31	7-1-1	TI03/TO03/INTP4/PCLBUZ0	P40	7-1-1	I/O
P10	8-1-2	I/O	Input port	SCK00/SCL00/(TI07)/(TO07)	Port 1. 8-bit I/O port. Input/output can be specified in 1-bit units. Use of an on-chip pull-up resistor can be specified by a software setting at input port. Input of P10, P11, and P13 to P17 can be set to TTL input buffer. Output of P10 to P15, and P17 can be set to N-ch open-drain output (V_{DD} tolerance).																																																						
P11	8-1-2			SI00/RxD0/TOOLRxD/SDA00/(TI06)/(TO06)																																																							
P12	7-1-2			SO00/TxD0/TOOLTxD/(TI05)/(TO05)																																																							
P13	8-1-2			TxD2/SO20/(SDAA0)/(TI04)/(TO04)																																																							
P14	8-1-2			RxD2/SI20/SDA20/(SCLA0)/(TI03)/(TO03)																																																							
P15	8-1-2			PCLBUZ1/SCK20/SCL20/(TI02)/(TO02)																																																							
P16	8-1-1			TI01/TO01/INTP5/(RxD0)																																																							
P17	8-1-2			TI02/TO02/(TxD0)																																																							
P20	4-3-1	I/O	Analog input port	ANI0/ AV_{REFP}	Port 2. 4-bit I/O port. Input/output can be specified in 1-bit units. Can be set to analog input Note 2 .																																																						
P21	4-3-1			ANI1/ AV_{REFM}																																																							
P22	4-3-1			ANI2																																																							
P23	4-3-1			ANI3																																																							
P30	7-1-1	I/O	Input port	INTP3/SCK11/SCL11	Port 3. 2-bit I/O port. Input/output can be specified in 1-bit units. Use of an on-chip pull-up resistor can be specified by a software setting at input port.																																																						
P31	7-1-1			TI03/TO03/INTP4/PCLBUZ0																																																							
P40	7-1-1	I/O	Input port	TOOL0	Port 4. 1-bit I/O port. Input/output can be specified in 1-bit units. Use of an on-chip pull-up resistor can be specified by a software setting at input port.																																																						

Notes 1. Digital or analog for each pin can be selected with the port mode control register x (PMCx) (can be set in 1-bit unit).

2. Digital or analog for each pin can be selected with the A/D port configuration register (ADPC).

Remark Functions in parentheses in the above figure can be assigned via settings in the peripheral I/O redirection register (PIOR). Refer to **Figure 4-8 Format of Peripheral I/O Redirection Register (PIOR)**.

(2/2)

Function Name	Pin Type	I/O	After Reset Release	Alternate Function	Function
P50	7-1-2	I/O	Input port	INTP1/SI11/SDA11	Port 5. 2-bit I/O port. Input/output can be specified in 1-bit units. Use of an on-chip pull-up resistor can be specified by a software setting at input port. Output of P50 can be set to N-ch open-drain output (V_{DD} tolerance).
P51	7-1-1			INTP2/SO11	
P60	12-1-1	I/O	Input port	SCLA0	Port 6. 2-bit I/O port. Input/output can be specified in 1-bit units. Output of P60 and P61 can be set to N-ch open-drain output (6 V tolerance).
P61				SDAA0	
P120	7-3-1	I/O	Analog input port	ANI19	Port 12. 1-bit I/O port and 2-bit input only port. P120 can be set to analog input Note . For only P120, input/output can be specified in 1-bit units. For only P120, use of an on-chip pull-up resistor can be specified by a software setting at input port.
P121	2-2-1	Input	Input port	X1	
P122				X2/EXCLK	
P137	2-1-2	Input	Input port	INTP0	Port 13 1-bit input only port
P147	7-3-1	I/O	Analog input port	ANI18	Port 14. 1-bit I/O port. Input/output can be specified in 1-bit units. Use of an on-chip pull-up resistor can be specified by a software setting at input port. P147 can be set to analog input Note .
$\overline{\text{RESET}}$	2-1-1	Input	—	—	Input only pin for external reset When external reset is not used, connect this pin to V_{DD} directly or via a resistor.

Note Digital or analog for each pin can be selected with the port mode control register x (PMCx) (can be set in 1-bit unit).

2.1.5 32-pin products

(1/2)

Function Name	Pin Type	I/O	After Reset Release	Alternate Function	Function																																																		
P00	7-3-2	I/O	Analog input port	ANI17/TI00/TxD1	Port 0. 2-bit I/O port. Input/output can be specified in 1-bit units. Use of an on-chip pull-up resistor can be specified by a software setting at input port. Input of P01 can be set to TTL input buffer. Output of P00 can be set to N-ch open-drain output (V_{DD} tolerance). P00 and P01 can be set to analog input Note 1 .																																																		
P01	8-3-1			ANI16/TO00/RxD1		P10	8-1-2	I/O	Input port	SCK00/SCL00/(TI07)/(TO07)	Port 1. 8-bit I/O port. Input/output can be specified in 1-bit units. Use of an on-chip pull-up resistor can be specified by a software setting at input port. Input of P10, P11, and P13 to P17 can be set to TTL input buffer. Output of P10 to P15, and P17 can be set to N-ch open-drain output (V_{DD} tolerance).	P11	8-1-2	SI00/RxD0/TOOLRxD/SDA00/(TI06)/(TO06)	P12	7-1-2	SO00/TxD0/TOOLTxD/(INTP5)/(TI05)/(TO05)	P13	8-1-2	TxD2/SO20/(SDAA0)/(TI04)/(TO04)	P14	RxD2/SI20/SDA20/(SCLA0)/(TI03)/(TO03)	P15	PCLBUZ1/SCK20/SCL20/(TI02)/(TO02)	P16	8-1-1	TI01/TO01/INTP5/(RxD0)		P17	8-1-2	TI02/TO02/(TxD0)		P20	4-3-1	I/O	Analog input port	ANI0/AV _{REFP}	Port 2. 4-bit I/O port. Input/output can be specified in 1-bit units. Can be set to analog input Note 2 .	P21	ANI1/AV _{REFM}	P22	ANI2	P23	ANI3	P30	7-1-1	I/O	Input port	INTP3/SCK11/SCL11	Port 3. 2-bit I/O port. Input/output can be specified in 1-bit units. Use of an on-chip pull-up resistor can be specified by a software setting at input port.	P31	TI03/TO03/INTP4/PCLBUZ0	P40	7-1-1	I/O
P10	8-1-2	I/O	Input port	SCK00/SCL00/(TI07)/(TO07)	Port 1. 8-bit I/O port. Input/output can be specified in 1-bit units. Use of an on-chip pull-up resistor can be specified by a software setting at input port. Input of P10, P11, and P13 to P17 can be set to TTL input buffer. Output of P10 to P15, and P17 can be set to N-ch open-drain output (V_{DD} tolerance).																																																		
P11	8-1-2			SI00/RxD0/TOOLRxD/SDA00/(TI06)/(TO06)																																																			
P12	7-1-2			SO00/TxD0/TOOLTxD/(INTP5)/(TI05)/(TO05)																																																			
P13	8-1-2			TxD2/SO20/(SDAA0)/(TI04)/(TO04)																																																			
P14				RxD2/SI20/SDA20/(SCLA0)/(TI03)/(TO03)																																																			
P15				PCLBUZ1/SCK20/SCL20/(TI02)/(TO02)																																																			
P16	8-1-1			TI01/TO01/INTP5/(RxD0)																																																			
P17	8-1-2			TI02/TO02/(TxD0)																																																			
P20	4-3-1	I/O	Analog input port	ANI0/AV _{REFP}	Port 2. 4-bit I/O port. Input/output can be specified in 1-bit units. Can be set to analog input Note 2 .																																																		
P21				ANI1/AV _{REFM}																																																			
P22				ANI2																																																			
P23				ANI3																																																			
P30	7-1-1	I/O	Input port	INTP3/SCK11/SCL11	Port 3. 2-bit I/O port. Input/output can be specified in 1-bit units. Use of an on-chip pull-up resistor can be specified by a software setting at input port.																																																		
P31				TI03/TO03/INTP4/PCLBUZ0																																																			
P40	7-1-1	I/O	Input port	TOOL0	Port 4. 1-bit I/O port. Input/output can be specified in 1-bit units. Use of an on-chip pull-up resistor can be specified by a software setting at input port.																																																		

Notes 1. Digital or analog for each pin can be selected with the port mode control register x (PMCx) (can be set in 1-bit unit).

2. Digital or analog for each pin can be selected with the A/D port configuration register (ADPC).

Remark Functions in parentheses in the above figure can be assigned via settings in the peripheral I/O redirection register (PIOR). Refer to **Figure 4-8 Format of Peripheral I/O Redirection Register (PIOR)**.

(2/2)

Function Name	Pin Type	I/O	After Reset Release	Alternate Function	Function
P50	7-1-2	I/O	Input port	INTP1/SI11/SDA11	Port 5. 2-bit I/O port. Input/output can be specified in 1-bit units. Use of an on-chip pull-up resistor can be specified by a software setting at input port. Output of P50 can be set to N-ch open-drain output (V_{DD} tolerance).
P51	7-1-1			INTP2/SO11	
P60	12-1-1	I/O	Input port	SCLA0	Port 6. 3-bit I/O port. Input/output can be specified in 1-bit units. Output of P60 to P62 can be set to N-ch open-drain output (6 V tolerance).
P61				SDAA0	
P62				—	
P70	7-1-1	I/O	Input port	—	Port 7. 1-bit I/O port. Input/output can be specified in 1-bit units. Use of an on-chip pull-up resistor can be specified by a software setting at input port.
P120	7-3-1	I/O	Analog input port	ANI19	Port 12. 1-bit I/O port and 2-bit input only port. For only P120, input/output can be specified in 1-bit units. For only P120, use of an on-chip pull-up resistor can be specified by a software setting at input port. P120 can be set to analog input Note .
P121	2-2-1	Input	Input port	X1	
P122				X2/EXCLK	
P137	2-1-2	Input	Input port	INTP0	Port 13 1bit input only port.
P147	7-3-1	I/O	Analog input port	ANI18	Port 14. 1-bit I/O port. Input/output can be specified in 1-bit units. Use of an on-chip pull-up resistor can be specified by a software setting at input port. P147 can be set to analog input Note .
$\overline{\text{RESET}}$	2-1-1	Input	—	—	Input only pin for external reset When external reset is not used, connect this pin to V_{DD} directly or via a resistor.

Note Digital or analog for each pin can be selected with the port mode control register x (PMCx) (can be set in 1-bit unit).

2.1.6 36-pin products

(1/2)

Function Name	Pin Type	I/O	After Reset Release	Alternate Function	Function																																																					
P00	7-1-2	I/O	Input port	TI00/TxD1	Port 0. 2-bit I/O port. Input/output can be specified in 1-bit units. Use of an on-chip pull-up resistor can be specified by a software setting at input port. Input of P01 can be set to TTL input buffer. Output of P00 can be set to N-ch open-drain output (V_{DD} tolerance).																																																					
P01	8-1-1			TO00/RxD1		P10	8-1-2	I/O	Input port	SCK00/SCL00 (TI07)/(TO07)	Port 1. 8-bit I/O port. Input/output can be specified in 1-bit units. Use of an on-chip pull-up resistor can be specified by a software setting at input port. Input of P10, P11, and P13 to P17 can be set to TTL input buffer. Output of P10 to P15, and P17 can be set to N-ch open-drain output (V_{DD} tolerance).	P11	SI00/RxD0/TOOLRxD/ SDA00/(TI06)/(TO06)	P12	7-1-2	SO00/TxD0/TOOLTxD/ (TI05)/(TO05)	P13	8-1-2	TxD2/SO20/(SDAA0)/ (TI04)/(TO04)	P14	RxD2/SI20/SDA20/ (SCLA0)/(TI03)/ (TO03)	P15	PCLBUZ1/SCK20/ SCL20/(TI02)/(TO02)	P16	8-1-1	TI01/TO01/INTP5/ (RxD0)		P17	8-1-2	TI02/TO02/(TxD0)		P20	4-3-1	I/O	Analog input port	ANI0/ AV_{REFP}	Port 2. 6-bit I/O port. Input/output can be specified in 1-bit units. Can be set to analog input Note .	P21	ANI1/ AV_{REFM}	P22	ANI2	P23	ANI3	P24	ANI4	P25	ANI5	P30	7-1-1	I/O	Input port	INTP3/ SCK11/SCL11	Port 3. 2-bit I/O port. Input/output can be specified in 1-bit units. Use of an on-chip pull-up resistor can be specified by a software setting at input port.	P31	TI03/TO03/INTP4/ PCLBUZ0	P40	7-1-1	I/O
P10	8-1-2	I/O	Input port	SCK00/SCL00 (TI07)/(TO07)	Port 1. 8-bit I/O port. Input/output can be specified in 1-bit units. Use of an on-chip pull-up resistor can be specified by a software setting at input port. Input of P10, P11, and P13 to P17 can be set to TTL input buffer. Output of P10 to P15, and P17 can be set to N-ch open-drain output (V_{DD} tolerance).																																																					
P11				SI00/RxD0/TOOLRxD/ SDA00/(TI06)/(TO06)																																																						
P12	7-1-2			SO00/TxD0/TOOLTxD/ (TI05)/(TO05)																																																						
P13	8-1-2			TxD2/SO20/(SDAA0)/ (TI04)/(TO04)																																																						
P14				RxD2/SI20/SDA20/ (SCLA0)/(TI03)/ (TO03)																																																						
P15				PCLBUZ1/SCK20/ SCL20/(TI02)/(TO02)																																																						
P16	8-1-1			TI01/TO01/INTP5/ (RxD0)																																																						
P17	8-1-2			TI02/TO02/(TxD0)																																																						
P20	4-3-1	I/O	Analog input port	ANI0/ AV_{REFP}	Port 2. 6-bit I/O port. Input/output can be specified in 1-bit units. Can be set to analog input Note .																																																					
P21				ANI1/ AV_{REFM}																																																						
P22				ANI2																																																						
P23				ANI3																																																						
P24				ANI4																																																						
P25				ANI5																																																						
P30	7-1-1	I/O	Input port	INTP3/ SCK11/SCL11	Port 3. 2-bit I/O port. Input/output can be specified in 1-bit units. Use of an on-chip pull-up resistor can be specified by a software setting at input port.																																																					
P31				TI03/TO03/INTP4/ PCLBUZ0																																																						
P40	7-1-1	I/O	Input port	TOOL0	Port 4. 1-bit I/O port. Input/output can be specified in 1-bit units. Use of an on-chip pull-up resistor can be specified by a software setting at input port.																																																					

Note Digital or analog for each pin can be selected with the A/D port configuration register (ADPC).

Remark Functions in parentheses in the above figure can be assigned via settings in the peripheral I/O redirection register (PIOR). Refer to **Figure 4-8 Format of Peripheral I/O Redirection Register (PIOR)**.

(2/2)

Function Name	Pin Type	I/O	After Reset Release	Alternate Function	Function
P50	7-1-2	I/O	Input port	INTP1/SI11/SDA11	Port 5. 2-bit I/O port. Input/output can be specified in 1-bit units. Use of an on-chip pull-up resistor can be specified by a software setting at input port. Output of P50 can be set to N-ch open-drain output (V_{DD} tolerance).
P51	7-1-1			INTP2/SO11	
P60	12-1-1	I/O	Input port	SCLA0	Port 6. 3-bit I/O port. Input/output can be specified in 1-bit units. Output of P60 to P62 can be set to N-ch open-drain output (6 V tolerance).
P61				SDAA0	
P62				—	
P70	7-1-1	I/O	Input port	SCK21/SCL21	Port 7. 3-bit I/O port. Input/output can be specified in 1-bit units. Use of an on-chip pull-up resistor can be specified by a software setting at input port. Output of P71 can be set to N-ch open-drain output (V_{DD} tolerance).
P71	7-1-2			SI21/SDA21	
P72	7-1-1			SO21	
P120	7-3-1	I/O	Analog input port	ANI19	Port 12. 1-bit I/O port and 2-bit input only port. For only P120, input/output can be specified in 1-bit units. For only P120, use of an on-chip pull-up resistor can be specified by a software setting at input port. P120 can be set to analog input Note .
P121	2-2-1	Input	Input port	X1	
P122				X2/EXCLK	
P137	2-1-2	Input	Input port	INTP0	Port 13 1bit input only port.
P147	7-3-1	I/O	Analog input port	ANI18	Port 14. 1-bit I/O port. Input/output can be specified in 1-bit units. Use of an on-chip pull-up resistor can be specified by a software setting at input port. P147 can be set to analog input Note .
$\overline{\text{RESET}}$	2-1-1	Input	—	—	Input only pin for external reset When external reset is not used, connect this pin to V_{DD} directly or via a resistor.

Note Digital or analog for each pin can be selected with the port mode control register x (PMCx) (can be set in 1-bit unit).

2.1.7 40-pin products

(1/2)

Function Name	Pin Type	I/O	After Reset Release	Alternate Function	Function																																																															
P00	7-1-2	I/O	Input port	TI00/TxD1	Port 0. 2-bit I/O port. Input/output can be specified in 1-bit units. Use of an on-chip pull-up resistor can be specified by a software setting at input port. Input of P01 can be set to TTL input buffer. Output of P00 can be set to N-ch open-drain output (V_{DD} tolerance).																																																															
P01	8-1-1			TO00/RxD1		P10	8-1-2	I/O	Input port	SCK00/SCL00/(TI07)/(TO07)	Port 1. 8-bit I/O port. Input/output can be specified in 1-bit units. Use of an on-chip pull-up resistor can be specified by a software setting at input port. Input of P10, P11, and P13 to P17 can be set to TTL input buffer. Output of P10 to P15, and P17 can be set to N-ch open-drain output (V_{DD} tolerance).	P11		SI00/RxD0/TOOLRxD/SDA00/(TI06)/(TO06)	P12	7-1-2	SO00/TxD0/TOOLTxD/(TI05)/(TO05)	P13	8-1-2	TxD2/SO20/(SDAA0)/(TI04)/(TO04)	P14		RxD2/SI20/SDA20/(SCLA0)/(TI03)/(TO03)	P15		PCLBUZ1/SCK20/SCL20/(TI02)/(TO02)	P16	8-1-1	TI01/TO01/INTP5/(RxD0)	P17	8-1-2	TI02/TO02/(TxD0)	P20	4-3-1	I/O	Analog input port	ANI0/ AV_{REFP}	Port 2. 7-bit I/O port. Input/output can be specified in 1-bit units. Can be set to analog input Note .	P21		ANI1/ AV_{REFM}	P22		ANI2	P23		ANI3	P24		ANI4	P25		ANI5	P26		ANI6	P30	7-1-1	I/O	Input port	INTP3/RTC1HZ/SCK11/SCL11	Port 3. 2-bit I/O port. Input/output can be specified in 1-bit units. Use of an on-chip pull-up resistor can be specified by a software setting at input port.	P31		TI03/TO03/INTP4/PCLBUZ0	P40	7-1-1	I/O
P10	8-1-2	I/O	Input port	SCK00/SCL00/(TI07)/(TO07)	Port 1. 8-bit I/O port. Input/output can be specified in 1-bit units. Use of an on-chip pull-up resistor can be specified by a software setting at input port. Input of P10, P11, and P13 to P17 can be set to TTL input buffer. Output of P10 to P15, and P17 can be set to N-ch open-drain output (V_{DD} tolerance).																																																															
P11				SI00/RxD0/TOOLRxD/SDA00/(TI06)/(TO06)																																																																
P12	7-1-2			SO00/TxD0/TOOLTxD/(TI05)/(TO05)																																																																
P13	8-1-2			TxD2/SO20/(SDAA0)/(TI04)/(TO04)																																																																
P14				RxD2/SI20/SDA20/(SCLA0)/(TI03)/(TO03)																																																																
P15				PCLBUZ1/SCK20/SCL20/(TI02)/(TO02)																																																																
P16	8-1-1			TI01/TO01/INTP5/(RxD0)																																																																
P17	8-1-2			TI02/TO02/(TxD0)																																																																
P20	4-3-1	I/O	Analog input port	ANI0/ AV_{REFP}	Port 2. 7-bit I/O port. Input/output can be specified in 1-bit units. Can be set to analog input Note .																																																															
P21				ANI1/ AV_{REFM}																																																																
P22				ANI2																																																																
P23				ANI3																																																																
P24				ANI4																																																																
P25				ANI5																																																																
P26				ANI6																																																																
P30	7-1-1	I/O	Input port	INTP3/RTC1HZ/SCK11/SCL11	Port 3. 2-bit I/O port. Input/output can be specified in 1-bit units. Use of an on-chip pull-up resistor can be specified by a software setting at input port.																																																															
P31				TI03/TO03/INTP4/PCLBUZ0																																																																
P40	7-1-1	I/O	Input port	TOOL0	Port 4. 1-bit I/O port. Input/output can be specified in 1-bit units. Use of an on-chip pull-up resistor can be specified by a software setting at input port.																																																															

Note Digital or analog for each pin can be selected with the A/D port configuration register (ADPC).

Remark Functions in parentheses in the above figure can be assigned via settings in the peripheral I/O redirection register (PIOR). Refer to **Figure 4-8 Format of Peripheral I/O Redirection Register (PIOR)**.

(2/2)

Function Name	Pin Type	I/O	After Reset Release	Alternate Function	Function
P50	7-1-2	I/O	Input port	INTP1/SI11/SDA11	Port 5. 2-bit I/O port. Output of P50 can be set to N-ch open-drain output (V_{DD} tolerance). Input/output can be specified in 1-bit units. Use of an on-chip pull-up resistor can be specified by a software setting at input port.
P51	7-1-1			INTP2/SO11	
P60	12-1-1	I/O	Input port	SCLA0	Port 6. 3-bit I/O port. Input/output can be specified in 1-bit units. Output of P60 to P62 can be set to N-ch open-drain output (6 V tolerance).
P61				SDAA0	
P62				—	
P70	7-1-1	I/O	Input port	KR0/SCK21/SCL21	Port 7. 4-bit I/O port. Input/output can be specified in 1-bit units. Use of an on-chip pull-up resistor can be specified by a software setting at input port. Output of P71 can be set to N-ch open-drain output (V_{DD} tolerance).
P71	7-1-2			KR1/SI21/SDA21	
P72	7-1-1			KR2/SO21	
P73				KR3	
P120	7-3-1	I/O	Analog input port	ANI19	Port 12. 1-bit I/O port and 4-bit input only port. For only P120, input/output can be specified in 1-bit units. For only P120, use of an on-chip pull-up resistor can be specified by a software setting at input port. P120 can be set to analog input Note .
P121	2-2-1	Input	Input port	X1	
P122				X2/EXCLK	
P123				XT1	
P124				XT2/EXCLKS	
P137	2-1-2	Input	Input port	INTP0	Port 13. 1-bit input only port.
P147	7-3-1	I/O	Analog input port	ANI18	Port 14. 1-bit I/O port. Input/output can be specified in 1-bit units. Use of an on-chip pull-up resistor can be specified by a software setting at input port. P147 can be set to analog input Note .
$\overline{\text{RESET}}$	2-1-1	Input	—	—	Input only pin for external reset When external reset is not used, connect this pin to V_{DD} directly or via a resistor.

Note Digital or analog for each pin can be selected with the port mode control register x (PMCx) (can be set in 1-bit unit).

Remark Functions in parentheses in the above figure can be assigned via settings in the peripheral I/O redirection register (PIOR). Refer to **Figure 4-8 Format of Peripheral I/O Redirection Register (PIOR)**.

2.1.8 44-pin products

(1/2)

Function Name	Pin Type	I/O	After Reset Release	Alternate Function	Function																																																						
P00	7-1-2	I/O	Input port	TI00/TxD1	Port 0. 2-bit I/O port. Input/output can be specified in 1-bit units. Use of an on-chip pull-up resistor can be specified by a software setting at input port. Input of P01 can be set to TTL input buffer. Output of P00 can be set to N-ch open-drain output (V_{DD} tolerance).																																																						
P01	8-1-1			TO00/RxD1		P10	8-1-2	I/O	Input port	SCK00/SCL00/ (TI07)/(TO07)	Port 1. 8-bit I/O port. Input/output can be specified in 1-bit units. Use of an on-chip pull-up resistor can be specified by a software setting at input port. Input of P10, P11, and P13 to P17 can be set to TTL input buffer. Output of P10 to P15, and P17 can be set to N-ch open-drain output (V_{DD} tolerance).	P11		SI00/RxD0/ TOOLRxD/SDA00/ (TI06)/(TO06)	P12	7-1-2	SO00/TxD0/ TOOLTxD/(TI05)/ (TO05)	P13	8-1-2	TxD2/SO20/ (SDAA0)/(TI04)/ (TO04)	P14	RxD2/SI20/SDA20/ (SCLA0)/(TI03)/ (TO03)	P15	PCLBUZ1/SCK20/ SCL20/(TI02)/(TO02)	P16	8-1-1		TI01/TO01/INTP5/ (RxD0)		P17	8-1-2		TI02/TO02/(TxD0)		P20	4-3-1	I/O	Analog input port	ANI0/AV _{REFP}	Port 2. 8-bit I/O port. Input/output can be specified in 1-bit units. Can be set to analog input Note .	P21	ANI1/AV _{REFM}	P22	ANI2	P23	ANI3	P24	ANI4	P25	ANI5	P26	ANI6	P27	ANI7	P30	7-1-1	I/O	Input port	INTP3/RTC1HZ/ SCK11/SCL11
P10	8-1-2	I/O	Input port	SCK00/SCL00/ (TI07)/(TO07)	Port 1. 8-bit I/O port. Input/output can be specified in 1-bit units. Use of an on-chip pull-up resistor can be specified by a software setting at input port. Input of P10, P11, and P13 to P17 can be set to TTL input buffer. Output of P10 to P15, and P17 can be set to N-ch open-drain output (V_{DD} tolerance).																																																						
P11				SI00/RxD0/ TOOLRxD/SDA00/ (TI06)/(TO06)																																																							
P12	7-1-2			SO00/TxD0/ TOOLTxD/(TI05)/ (TO05)																																																							
P13	8-1-2			TxD2/SO20/ (SDAA0)/(TI04)/ (TO04)																																																							
P14				RxD2/SI20/SDA20/ (SCLA0)/(TI03)/ (TO03)																																																							
P15				PCLBUZ1/SCK20/ SCL20/(TI02)/(TO02)																																																							
P16	8-1-1					TI01/TO01/INTP5/ (RxD0)																																																					
P17	8-1-2					TI02/TO02/(TxD0)																																																					
P20	4-3-1	I/O	Analog input port	ANI0/AV _{REFP}	Port 2. 8-bit I/O port. Input/output can be specified in 1-bit units. Can be set to analog input Note .																																																						
P21				ANI1/AV _{REFM}																																																							
P22				ANI2																																																							
P23				ANI3																																																							
P24				ANI4																																																							
P25				ANI5																																																							
P26				ANI6																																																							
P27				ANI7																																																							
P30	7-1-1	I/O	Input port	INTP3/RTC1HZ/ SCK11/SCL11	Port 3. 2-bit I/O port. Input/output can be specified in 1-bit units. Use of an on-chip pull-up resistor can be specified by a software setting at input port.																																																						
P31				TI03/TO03/INTP4/ PCLBUZ0																																																							

Note Digital or analog for each pin can be selected with the A/D port configuration register (ADPC).

Remark Functions in parentheses in the above figure can be assigned via settings in the peripheral I/O redirection register (PIOR). Refer to **Figure 4-8 Format of Peripheral I/O Redirection Register (PIOR)**.

(2/2)

Function Name	Pin Type	I/O	After Reset Release	Alternate Function	Function
P40	7-1-1	I/O	Input port	TOOL0	Port 4. 2-bit I/O port. Input/output can be specified in 1-bit units. Use of an on-chip pull-up resistor can be specified by a software setting at input port.
P41				TI07/TO07	
P50	7-1-2	I/O	Input port	INTP1/SI11/SDA11	Port 5. 2-bit I/O port. Input/output can be specified in 1-bit units. Use of an on-chip pull-up resistor can be specified by a software setting at input port. Output of P50 can be set to N-ch open-drain output (V _{DD} tolerance).
P51	7-1-1			INTP2/SO11	
P60	12-1-1	I/O	Input port	SCLA0	Port 6. 4-bit I/O port. Input/output can be specified in 1-bit units. Output of P60 to P63 can be set to N-ch open-drain output (6 V tolerance).
P61				SDAA0	
P62				—	
P63				—	
P70	7-1-1	I/O	Input port	KR0/SCK21/SCL21	Port 7. 4-bit I/O port. Input/output can be specified in 1-bit units. Use of an on-chip pull-up resistor can be specified by a software setting at input port. Output of P71 can be set to N-ch open-drain output (V _{DD} tolerance).
P71	7-1-2			KR1/SI21/SDA21	
P72	7-1-1			KR2/SO21	
P73				KR3	
P120	7-3-1	I/O	Analog input port	ANI19	Port 12. 1-bit I/O port and 4-bit input only port. For only P120, input/output can be specified in 1-bit units. For only P120, use of an on-chip pull-up resistor can be specified by a software setting at input port. P120 can be set to analog input Note .
P121	2-2-1		Input port	X1	
P122				X2/EXCLK	
P123				XT1	
P124				XT2/EXCLKS	
P137	2-1-2	Input	Input port	INTP0	Port 13. 1-bit input only port.
P146	7-1-1	I/O	Input port	—	Port 14. 1-bit I/O port. Input/output can be specified in 1-bit units. Use of an on-chip pull-up resistor can be specified by a software setting at input port. P147 can be set to analog input Note .
P147	7-3-1		Analog input port	ANI18	
$\overline{\text{RESET}}$	2-1-1	Input	—	—	Input only pin for external reset When external reset is not used, connect this pin to V _{DD} directly or via a resistor.

Note Digital or analog for each pin can be selected with the port mode control register x (PMCx) (can be set in 1-bit unit).

2.1.9 48-pin products

(1/2)

Function Name	Pin Type	I/O	After Reset Release	Alternate Function	Function																																																						
P00	7-1-2	I/O	Input port	TI00/TxD1	Port 0. 2-bit I/O port. Input/output can be specified in 1-bit units. Use of an on-chip pull-up resistor can be specified by a software setting at input port. Input of P01 can be set to TTL input buffer. Output of P00 can be set to N-ch open-drain output (V _{DD} tolerance).																																																						
P01	8-1-1			TO00/RxD1		P10	8-1-2	I/O	Input port	SCK00/SCL00/(TI07)/(TO07)	Port 1. 8-bit I/O port. Input/output can be specified in 1-bit units. Use of an on-chip pull-up resistor can be specified by a software setting at input port. Input of P10, P11, and P13 to P17 can be set to TTL input buffer. Output of P10 to P15, and P17 can be set to N-ch open-drain output (V _{DD} tolerance).	P11		SI00/RxD0/TOOLRx D/SDA00/(TI06)/(TO06)	P12	7-1-2	SO00/TxD0/TOOLTxD/(TI05)/(TO05)	P13	8-1-2	TxD2/SO20/(SDAA0)/(TI04)/(TO04)	P14	RxD2/SI20/SDA20/(SCLA0)/(TI03)/(TO03)	P15	PCLBUZ1/SCK20/SCL20/(TI02)/(TO02)	P16	8-1-1		TI01/TO01/INTP5/(RxD0)		P17	8-1-2		TI02/TO02/(TxD0)		P20	4-3-1	I/O	Analog input port	ANI0/AV _{REFP}	Port 2. 8-bit I/O port. Input/output can be specified in 1-bit units. Can be set to analog input Note .	P21	ANI1/AV _{REFM}	P22	ANI2	P23	ANI3	P24	ANI4	P25	ANI5	P26	ANI6	P27	ANI7	P30	7-1-1	I/O	Input port	INTP3/RTC1HZ/SCK11/SCL11
P10	8-1-2	I/O	Input port	SCK00/SCL00/(TI07)/(TO07)	Port 1. 8-bit I/O port. Input/output can be specified in 1-bit units. Use of an on-chip pull-up resistor can be specified by a software setting at input port. Input of P10, P11, and P13 to P17 can be set to TTL input buffer. Output of P10 to P15, and P17 can be set to N-ch open-drain output (V _{DD} tolerance).																																																						
P11				SI00/RxD0/TOOLRx D/SDA00/(TI06)/(TO06)																																																							
P12	7-1-2			SO00/TxD0/TOOLTxD/(TI05)/(TO05)																																																							
P13	8-1-2			TxD2/SO20/(SDAA0)/(TI04)/(TO04)																																																							
P14				RxD2/SI20/SDA20/(SCLA0)/(TI03)/(TO03)																																																							
P15				PCLBUZ1/SCK20/SCL20/(TI02)/(TO02)																																																							
P16	8-1-1					TI01/TO01/INTP5/(RxD0)																																																					
P17	8-1-2					TI02/TO02/(TxD0)																																																					
P20	4-3-1	I/O	Analog input port	ANI0/AV _{REFP}	Port 2. 8-bit I/O port. Input/output can be specified in 1-bit units. Can be set to analog input Note .																																																						
P21				ANI1/AV _{REFM}																																																							
P22				ANI2																																																							
P23				ANI3																																																							
P24				ANI4																																																							
P25				ANI5																																																							
P26				ANI6																																																							
P27				ANI7																																																							
P30	7-1-1	I/O	Input port	INTP3/RTC1HZ/SCK11/SCL11	Port 3. 2-bit I/O port. Input/output can be specified in 1-bit units. Use of an on-chip pull-up resistor can be specified by a software setting at input port.																																																						
P31				TI03/TO03/INTP4/PCLBUZ0																																																							

Note Digital or analog for each pin can be selected with the A/D port configuration register (ADPC).

Remark Functions in parentheses in the above figure can be assigned via settings in the peripheral I/O redirection register (PIOR). Refer to **Figure 4-8 Format of Peripheral I/O Redirection Register (PIOR)**.

(2/2)

Function Name	Pin Type	I/O	After Reset Release	Alternate Function	Function
P40	7-1-1	I/O	Input port	TOOL0	Port 4. 2-bit I/O port. Input/output can be specified in 1-bit units. Use of an on-chip pull-up resistor can be specified by a software setting at input port.
P41				TI07/TO07	
P50	7-1-2	I/O	Input port	INTP1/SI11/SDA11	Port 5. 2-bit I/O port. Input/output can be specified in 1-bit units. Use of an on-chip pull-up resistor can be specified by a software setting at input port. Output of P50 can be set to N-ch open-drain output (V_{DD} tolerance).
P51	7-1-1			INTP2/SO11	
P60	12-1-1	I/O	Input port	SCLA0	Port 6. 4-bit I/O port. Input/output can be specified in 1-bit units. Output of P60 to P63 can be set to N-ch open-drain output (6 V tolerance).
P61				SDAA0	
P62				—	
P63				—	
P70	7-1-1	I/O	Input port	KR0/SCK21/SCL21	Port 7. 6-bit I/O port. Input/output can be specified in 1-bit units. Use of an on-chip pull-up resistor can be specified by a software setting at input port. Output of P71 and P74 can be set to N-ch open-drain output (V_{DD} tolerance).
P71	7-1-2			KR1/SI21/SDA21	
P72	7-1-1			KR2/SO21	
P73				KR3/SO01	
P74	7-1-2			KR4/INTP8/SI01/SDA01	
P75	7-1-1			KR5/INTP9/SCK01/SCL01	
P120	7-3-1	I/O	Analog input port	ANI19	Port 12.
P121	2-2-1	Input	Input port	X1	1-bit I/O port and 4-bit input only port. For only P120, input/output can be specified in 1-bit units.
P122				X2/EXCLK	
P123				XT1	For only P120, use of an on-chip pull-up resistor can be specified by a software setting at input port.
P124				XT2/EXCLKS	P120 can be set to analog input Note .
P130	1-1-1	Output	Output port	—	Port 13.
P137	2-1-2	Input	Input port	INTP0	1-bit output port and 1-bit input only port.
P140	7-1-1	I/O	Input port	PCLBUZ0/INTP6	Port 14. 3-bit I/O port. Input/output can be specified in 1-bit units. Use of an on-chip pull-up resistor can be specified by a software setting at input port. P147 can be set to analog input Note .
P146				—	
P147	7-3-1		Analog input port	ANI18	
RESET	2-1-1	Input	—	—	Input only pin for external reset When external reset is not used, connect this pin to V_{DD} directly or via a resistor.

Note Digital or analog for each pin can be selected with the port mode control register x (PMCx) (can be set in 1-bit unit).

Remark Functions in parentheses in the above figure can be assigned via settings in the peripheral I/O redirection register (PIOR). Refer to **Figure 4-8 Format of Peripheral I/O Redirection Register (PIOR)**.

2.1.10 52-pin products

(1/2)

Function Name	Pin Type	I/O	After Reset Release	Alternate Function	Function
P00	7-1-2	I/O	Input port	TI00	Port 0. 4-bit I/O port. Input/output can be specified in 1-bit units. Use of an on-chip pull-up resistor can be specified by a software setting at input port. Input of P01 and P03 can be set to TTL input buffer. Output of P00, P02, and P03 can be set to N-ch open-drain output (V_{DD} tolerance). P02 and P03 can be set to analog input Note 1 .
P01	8-1-1			TO00	
P02	7-3-2		Analog input port	ANI17/TxD1	
P03	8-3-2			ANI16/RxD1	
P10	8-1-2	I/O	Input port	SCK00/SCL00/(TI07)/(TO07)	Port 1. 8-bit I/O port. Input/output can be specified in 1-bit units. Use of an on-chip pull-up resistor can be specified by a software setting at input port. Input of P10, P11, and P13 to P17 can be set to TTL input buffer. Output of P10 to P15, and P17 can be set to N-ch open-drain output (V_{DD} tolerance).
P11				SI00/RxD0/TOOLRxD/SDA00/(TI06)/(TO06)	
P12	7-1-2			SO00/TxD0/TOOLTxD/(TI05)/(TO05)	
P13	8-1-2			TxD2/SO20/(SDAA0)/(TI04)/(TO04)	
P14				RxD2/SI20/SDA20/(SCLA0)/(TI03)/(TO03)	
P15				PCLBUZ1/SCK20/SCL20/(TI02)/(TO02)	
P16	8-1-1			TI01/TO01/INTP5/(RxD0)	
P17	8-1-2			TI02/TO02/(TxD0)	
P20	4-3-1	I/O	Analog input port	ANI0/ AV_{REFP}	Port 2. 8-bit I/O port. Input/output can be specified in 1-bit units. Can be set to analog input Note 2 .
P21				ANI1/ AV_{REFM}	
P22				ANI2	
P23				ANI3	
P24				ANI4	
P25				ANI5	
P26				ANI6	
P27				ANI7	
P30	7-1-1	I/O	Input port	INTP3/RTC1HZ/SCK11/SCL11	Port 3. 2-bit I/O port. Input/output can be specified in 1-bit units. Use of an on-chip pull-up resistor can be specified by a software setting at input port.
P31				TI03/TO03/INTP4/PCLBUZ0	

- Notes 1.** Digital or analog for each pin can be selected with the port mode control register x (PMCx) (can be set in 1-bit unit).
- 2.** Digital or analog for each pin can be selected with the A/D port configuration register (ADPC).

Remark Functions in parentheses in the above figure can be assigned via settings in the peripheral I/O redirection register (PIOR). Refer to **Figure 4-8 Format of Peripheral I/O Redirection Register (PIOR)**.

(2/2)

Function Name	Pin Type	I/O	After Reset Release	Alternate Function	Function
P40	7-1-1	I/O	Input port	TOOL0	Port 4. 2-bit I/O port. Input/output can be specified in 1-bit units. Use of an on-chip pull-up resistor can be specified by a software setting at input port.
P41				TI07/TO07	
P50	7-1-2	I/O	Input port	INTP1/SI11/SDA11	Port 5. 2-bit I/O port. Input/output can be specified in 1-bit units. Use of an on-chip pull-up resistor can be specified by a software setting at input port. Output of P50 can be set to N-ch open-drain output (V_{DD} tolerance).
P51	7-1-1			INTP2/SO11	
P60	12-1-1	I/O	Input port	SCLA0	Port 6. 4-bit I/O port. Input/output can be specified in 1-bit units. Output of P60 to P63 can be set to N-ch open-drain output (6 V tolerance).
P61				SDAA0	
P62				—	
P63				—	
P70	7-1-1	I/O	Input port	KR0/SCK21/SCL21	Port 7. 8-bit I/O port. Input/output can be specified in 1-bit units. Use of an on-chip pull-up resistor can be specified by a software setting at input port. Output of P71 and P74 can be set to N-ch open-drain output (V_{DD} tolerance).
P71	7-1-2			KR1/SI21/SDA21	
P72	7-1-1			KR2/SO21	
P73				KR3/SO01	
P74	7-1-2			KR4/INTP8/SI01/SDA01	
P75	7-1-1			KR5/INTP9/SCK01/SCL01	
P76				KR6/INTP10/(Rx)D2)	
P77				KR7/INTP11/(Tx)D2)	
P120	7-3-1	I/O	Analog input port	ANI19	Port 12. 1-bit I/O port and 4-bit input only port. For only P120, input/output can be specified in 1-bit units. For only P120, use of an on-chip pull-up resistor can be specified by a software setting at input port. P120 can be set to analog input ^{Note} .
P121	2-2-1	Input	Input port	X1	
P122				X2/EXCLK	
P123				XT1	
P124				XT2/EXCLKS	
P130	1-1-1	Output	Output port	—	Port 13. 1-bit output port and 1-bit input only port.
P137	2-1-2	Input	Input port	INTP0	
P140	7-1-1	I/O	Input port	PCLBUZ0/INTP6	Port 14. 3-bit I/O port. Input/output can be specified in 1-bit units. Use of an on-chip pull-up resistor can be specified by a software setting at input port. P147 can be set to analog input ^{Note} .
P146				—	
P147	7-3-1		Analog input port	ANI18	
$\overline{\text{RESET}}$	2-1-1	Input	—	—	Input only pin for external reset When external reset is not used, connect this pin to V_{DD} directly or via a resistor.

Note Digital or analog for each pin can be selected with the port mode control register x (PMCx) (can be set in 1-bit unit).

Remark Functions in parentheses in the above figure can be assigned via settings in the peripheral I/O redirection register (PIOR). Refer to **Figure 4-8 Format of Peripheral I/O Redirection Register (PIOR)**.

2.1.11 64-pin products

(1/2)

Function Name	Pin Type	I/O	After Reset Release	Alternate Function	Function
P00	7-1-2	I/O	Input port	TI00	Port 0. 7-bit I/O port. Input/output can be specified in 1-bit units. Use of an on-chip pull-up resistor can be specified by a software setting at input port. Input of P01, P03, and P04 can be set to TTL input buffer. Output of P00 and P02 to P04 can be set to N-ch open-drain output (EV _{DD} tolerance). P02 and P03 can be set to analog input Note 1 .
P01	8-1-1			TO00	
P02	7-3-2		Analog input port	ANI17/SO10/TxD1	
P03	8-3-2			ANI16/SI10/RxD1/SDA10	
P04	8-1-2		Input port	SCK10/SCL10	
P05	7-1-1			TI05/TO05	
P06				TI06/TO06	
P10	8-1-2	I/O	Input port	SCK00/SCL00/ (TI07)/(TO07)	Port 1. 8-bit I/O port. Input/output can be specified in 1-bit units. Use of an on-chip pull-up resistor can be specified by a software setting at input port. Input of P10, P11, and P13 to P17 can be set to TTL input buffer. Output of P10 to P15 and P17 can be set to N-ch open-drain output (EV _{DD} tolerance).
P11				SI00/RxD0/ TOOLRxD/SDA00/ (TI06)/(TO06)	
P12	7-1-2			SO00/TxD0/TOOLTxD/ (INTP5)/(TI05)/(TO05)	
P13	8-1-2			TxD2/SO20/ (SDAA0)/(TI04)/(TO04)	
P14				RxD2/SI20/SDA20/ (SCLA0)/(TI03)/(TO03)	
P15				SCK20/SCL20/ (TI02)/(TO02)	
P16	8-1-1			TI01/TO01/INTP5/ (SI00)/(RxD0)	
P17	8-1-2	TI02/TO02/(SO00)/(TxD0)			
P20	4-3-1	I/O	Analog input port	ANI0/AV _{REFP}	Port 2. 8-bit I/O port. Input/output can be specified in 1-bit units. Can be set to analog input Note 2 .
P21				ANI1/AV _{REFM}	
P22				ANI2	
P23				ANI3	
P24				ANI4	
P25				ANI5	
P26				ANI6	
P27				ANI7	
P30	7-1-1	I/O	Input port	INTP3/RTC1HZ/ SCK11/SCL11	Port 3. 2-bit I/O port. Input/output can be specified in 1-bit units. Use of an on-chip pull-up resistor can be specified by a software setting at input port.
P31				TI03/TO03/INTP4/ (PCLBUZ0)	
P40	7-1-1	I/O	Input port	TOOL0	Port 4. 2-bit I/O port. Input/output can be specified in 1-bit units. Use of an on-chip pull-up resistor can be specified by a software setting at input port.
P41				TI07/TO07	
P42				TI04/TO04	
P43				—	

Notes 1. Digital or analog for each pin can be selected with the port mode control register x (PMCx) (can be set in 1-bit unit).

2. Digital or analog for each pin can be selected with the A/D port configuration register (ADPC).

Remark Functions in parentheses in the above figure can be assigned via settings in the peripheral I/O redirection register (PIOR). Refer to **Figure 4-8 Format of Peripheral I/O Redirection Register (PIOR)**.

(2/2)

Function Name	Pin Type	I/O	After Reset Release	Alternate Function	Function
P40	7-1-1	I/O	Input port	TOOL0	Port 4. 2-bit I/O port. Input/output can be specified in 1-bit units. Use of an on-chip pull-up resistor can be specified by a software setting at input port.
P41				TI07/TO07	
P42				TI04/TO04	
P43				—	
P50	7-1-2	I/O	Input port	INTP1/SI11/SDA11	Port 5. 6-bit I/O port. Input of P55 can be set to TTL input buffer. Output of P50 and P55 can be set to N-ch open-drain output (EV _{DD} tolerance). Input/output can be specified in 1-bit units. Use of an on-chip pull-up resistor can be specified by a software setting at input port.
P51	7-1-1			INTP2/SO11	
P52	7-1-1			(INTP10)	
P53				(INTP11)	
P54				—	
P55	8-1-2			(PCLBUZ1)/(SCK00)	
P60	12-1-1	I/O	Input port	SCLA0	Port 6. 4-bit I/O port. Input/output can be specified in 1-bit units. Output of P60 to P63 can be set to N-ch open-drain output (6 V tolerance).
P61				SDAA0	
P62				—	
P63				—	
P70	7-1-1	I/O	Input port	KR0/SCK21/SCL21	Port 7. 8-bit I/O port. Output of P71 and P74 can be set to N-ch open-drain output (V _{DD} tolerance). Input/output can be specified in 1-bit units. Use of an on-chip pull-up resistor can be specified by a software setting at input port.
P71	7-1-2			KR1/SI21/SDA21	
P72	7-1-1			KR2/SO21	
P73				KR3/SO01	
P74	7-1-2			KR4/INTP8/SI01/SDA01	
P75	7-1-1			KR5/INTP9/SCK01/SCL01	
P76				KR6/INTP10/(RxD2)	
P77				KR7/INTP11/(TxD2)	
P120	7-3-1	I/O	Analog input port	ANI19	Port 12. 1-bit I/O port and 4-bit input only port.
P121	2-2-1	Input	Input port	X1	For only P120, input/output can be specified in 1-bit units. For only P120, use of an on-chip pull-up resistor can be specified by a software setting at input port. P120 can be set to analog input Note .
P122				X2/EXCLK	
P123				XT1	
P124				XT2/EXCLKS	
P130	1-1-1	Output	Output port	—	Port 13. 1-bit output port and 1-bit input only port.
P137	2-1-2	Input	Input port	INTP0	
P140	7-1-1	I/O	Input port	PCLBUZ0/INTP6	Port 14. 4-bit I/O port. Input/output can be specified in 1-bit units. Use of an on-chip pull-up resistor can be specified by a software setting at input port. P147 can be set to analog input Note .
P141				PCLBUZ1/INTP7	
P146				—	
P147	7-3-1		Analog input port	ANI18	
$\overline{\text{RESET}}$	2-1-1	Input	—	—	Input only pin for external reset When external reset is not used, connect this pin to V _{DD} directly or via a resistor.

Note Digital or analog for each pin can be selected with the port mode control register x (PMCx) (can be set in 1-bit unit).

Remark Functions in parentheses in the above figure can be assigned via settings in the peripheral I/O redirection register (PIOR). Refer to **Figure 4-8 Format of Peripheral I/O Redirection Register (PIOR)**.

2.1.12 80-pin products

(1/3)

Function Name	Pin Type	I/O	After Reset Release	Alternate Function	Function
P00	7-1-2	I/O	Input port	TI00	Port 0. 7-bit I/O port. Input/output can be specified in 1-bit units. Use of an on-chip pull-up resistor can be specified by a software setting at input port. Input of P01, P03, and P04 can be set to TTL input buffer. Output of P00 and P02 to P04 can be set to N-ch open-drain output (EV _{DD} tolerance). P02 and P03 can be set to analog input Note 1 .
P01	8-1-1			TO00	
P02	7-3-2		Analog input port	ANI17/SO10/TxD1	
P03	8-3-2			ANI16/SI10/RxD1/ SDA10	
P04	8-1-2		Input port	SCK10/SCL10	
P05	7-1-1			TI05/TO05	
P06				TI06/TO06	
P10	8-1-2	I/O	Input port	SCK00/SCL00/ (TI07)/(TO07)	Port 1. 8-bit I/O port. Input/output can be specified in 1-bit units. Use of an on-chip pull-up resistor can be specified by a software setting at input port. Input of P10, P11, and P13 to P17 can be set to TTL input buffer. Output of P10 to P15, and P17 can be set to N-ch open-drain output (EV _{DD} tolerance).
P11				SI00/RxD0/ TOOLRxD/SDA00/ (TI06)/(TO06)	
P12	7-1-2		SO00/TxD0/ TOOLTxD/(INTP5)/ (TI05)/(TO05)		
P13	8-1-2		TxD2/SO20/ (SDAA0)/(TI04)/ (TO04)		
P14			RxD2/SI20/SDA20/ (SCLA0)/(TI03)/ (TO03)		
P15			SCK20/SCL20/ (TI02)/(TO02)		
P16	8-1-1		TI01/TO01/INTP5/ (SI00)/(RxD0)		
P17	8-1-2		TI02/TO02/(SO00)/ (TxD0)		
P20	4-3-1	I/O	Analog input port	ANI0/AV _{REFP}	Port 2. 8-bit I/O port. Input/output can be specified in 1-bit units. Can be set to analog input Note 2 .
P21				ANI1/AV _{REFM}	
P22				ANI2	
P23				ANI3	
P24				ANI4	
P25				ANI5	
P26				ANI6	
P27				ANI7	
P30	7-1-1	I/O	Input port	INTP3/RTC1HZ/ SCK11/SCL11	Port 3. 2-bit I/O port. Input/output can be specified in 1-bit units. Use of an on-chip pull-up resistor can be specified by a software setting at input port.
P31				TI03/TO03/INTP4/ (PCLBUZ0)	

Notes 1. Digital or analog for each pin can be selected with the port mode control register x (PMCx) (can be set in 1-bit unit).

2. Digital or analog for each pin can be selected with the A/D port configuration register (ADPC).

Remark Functions in parentheses in the above figure can be assigned via settings in the peripheral I/O redirection register (PIOR). Refer to **Figure 4-8 Format of Peripheral I/O Redirection Register (PIOR)**.

(2/3)

Function Name	Pin Type	I/O	After Reset Release	Alternate Function	Function
P40	7-1-1	I/O	Input port	TOOL0	Port 4. 6-bit I/O port. Input/output can be specified in 1-bit units. Use of an on-chip pull-up resistor can be specified by a software setting at input port. Input of P43 and P44 can be set to TTL input buffer. Output of P43 to P45 can be set to N-ch open-drain output (EV _{DD} tolerance).
P41				TI07/TO07	
P42				TI04/TO04	
P43	8-1-2			SCK01/SCL01	
P44				SI01/SDA01	
P45	7-1-2			SO01	
P50	7-1-2	I/O	Input port	INTP1/SI11/SDA11	Port 5. 6-bit I/O port. Input/output can be specified in 1-bit units. Use of an on-chip pull-up resistor can be specified by a software setting at input port. Input of P53 to P55 can be set to TTL input buffer. Output of P50 and P52 to P55 can be set to N-ch open-drain output (EV _{DD} tolerance).
P51	7-1-1			INTP2/SO11	
P52	7-1-2			SO31	
P53	8-1-2			SI31/SDA31	
P54				SCK31/SCL31	
P55	(PCLBUZ1)/(SCK00)				
P60	12-1-1	I/O	Input port	SCLA0	Port 6. 8-bit I/O port. Input/output can be specified in 1-bit units. Output of P60 to P63 can be set to N-ch open-drain output (6 V tolerance). For P64 to P67, use of an on-chip pull-up resistor can be specified by a software setting at input port.
P61				SDAA0	
P62				SCLA1	
P63				SDAA1	
P64	7-1-1			TI10/TO10	
P65				TI11/TO11	
P66				TI12/TO12	
P67				TI13/TO13	
P70	7-1-1	I/O	Input port	KR0/SCK21/SCL21	Port 7. 8-bit I/O port. Input/output can be specified in 1-bit units. Use of an on-chip pull-up resistor can be specified by a software setting at input port. Output of P71 and P74 can be set to N-ch open-drain output (EV _{DD} tolerance).
P71	7-1-2			KR1/SI21/SDA21	
P72	7-1-1			KR2/SO21	
P73				KR3	
P74	7-1-2			KR4/INTP8	
P75	7-1-1			KR5/INTP9	
P76				KR6/INTP10/(RxD2)	
P77				KR7/INTP11/(TxD2)	

Remark Functions in parentheses in the above figure can be assigned via settings in the peripheral I/O redirection register (PIOR). Refer to **Figure 4-8 Format of Peripheral I/O Redirection Register (PIOR)**.

(3/3)

Function Name	Pin Type	I/O	After Reset Release	Alternate Function	Function
P100	7-3-1	I/O	Analog input port	ANI20	Port 10. 1-bit I/O port. Input/output can be specified in 1-bit units. Use of an on-chip pull-up resistor can be specified by a software setting at input port. P100 can be set to analog input Note 1 .
P110	7-1-1	I/O	Input port	(INTP10)	Port 11. 2-bit I/O port. Input/output can be specified in 1-bit units. Use of an on-chip pull-up resistor can be specified by a software setting at input port.
P111				(INTP11)	
P120	7-3-1	I/O	Analog input port	ANI19	Port 12. 1-bit I/O port and 4-bit input only port. For only P120, input/output can be specified in 1-bit units. For only P120, use of an on-chip pull-up resistor can be specified by a software setting at input port. P120 can be set to analog input Note 1 .
P121	2-2-1	Input	Input port	X1	
P122				X2/EXCLK	
P123				XT1	
P124				XT2/EXCLKS	
P130	1-1-1	Output	Output port	—	Port 13. 1-bit output port and 1-bit input only port.
P137	2-1-2	Input	Input port	INTP0	
P140	7-1-1	I/O	Input port	PCLBUZ0/INTP6	Port 14. 7-bit I/O port. Input/output can be specified in 1-bit units in 1-bit units. Use of an on-chip pull-up resistor can be specified by a software setting at input port.
P141				PCLBUZ1/INTP7	
P142	8-1-2			SCK30/SCL30	
P143				SI30/RxD3/SDA30	
P144	7-1-2			SO30/TxD3	Input of P142 and P143 can be set to TTL input buffer. Output of P142 to P144 can be set to N-ch open-drain output (EV _{DD} tolerance). P147 can be set to analog input Note 1 .
P146	7-1-1			—	
P147	7-3-1		Analog input port	ANI18	
P150	4-3-1	I/O	Analog input port	ANI8	Port 15. 4-bit I/O port. Input/output can be specified in 1-bit units. Can be set to analog input Note 2 .
P151				ANI9	
P152				ANI10	
P153				ANI11	
$\overline{\text{RESET}}$	2-1-1	Input	—	—	Input only pin for external reset When external reset is not used, connect this pin to V _{DD} directly or via a resistor.

Notes 1. Digital or analog for each pin can be selected with the port mode control register x (PMCx) (can be set in 1-bit unit).

2. Digital or analog for each pin can be selected with the A/D port configuration register (ADPC).

Remark Functions in parentheses in the above figure can be assigned via settings in the peripheral I/O redirection register (PIOR). Refer to **Figure 4-8 Format of Peripheral I/O Redirection Register (PIOR)**.

2.1.13 100-pin products

(1/4)

Function Name	Pin Type	I/O	After Reset Release	Alternate Function	Function
P00	7-1-2	I/O	Input port	TI00	Port 0. 7-bit I/O port. Input/output can be specified in 1-bit units. Use of an on-chip pull-up resistor can be specified by a software setting at input port. Input of P01, P03 and P04 can be set to TTL input buffer. Output of P00, P02 to P04 can be set to N-ch open-drain output (EV _{DD} tolerance). P02 and P03 can be set to analog input Note 1 .
P01	8-1-1			TO00	
P02	7-3-2		Analog input port	ANI17/SO10/TxD1	
P03	8-3-2			ANI16/SI10/RxD1/ SDA10	
P04	8-1-2		Input port	SCK10/SCL10	
P05	7-1-1			—	
P06				—	
P10	8-1-2	I/O	Input port	SCK00/SCL00/(TI07)/ (TO07)	Port 1. 8-bit I/O port. Input/output can be specified in 1-bit units. Use of an on-chip pull-up resistor can be specified by a software setting at input port. Input of P10, P11, and P13 to P17 can be set to TTL input buffer. Output of P10 to P15, and P17 can be set to N-ch open-drain output (EV _{DD} tolerance).
P11				SI00/RxD0/ TOOLRxD/SDA00/ (TI06)/(TO06)	
P12	7-1-2			SO00/TxD0/TOOLTxD/ (INTP5)/(TI05)/(TO05)	
P13	8-1-2			TxD2/SO20/(SDAA0)/ (TI04)/(TO04)	
P14				RxD2/SI20/SDA20/ (SCLA0)/(TI03)/(TO03)	
P15				SCK20/SCL20/(TI02)/ (TO02)	
P16	8-1-1			TI01/TO01/INTP5/ (SI00)/(RxD0)	
P17	8-1-2			TI02/TO02/(SO00)/ (TxD0)	
P20	4-3-1	I/O	Analog input port	ANI0/AV _{REFP}	Port 2. 8-bit I/O port. Input/output can be specified in 1-bit units. Can be set to analog input Note 2 .
P21				ANI1/AV _{REFM}	
P22				ANI2	
P23				ANI3	
P24				ANI4	
P25				ANI5	
P26				ANI6	
P27				ANI7	
P30	7-1-1	I/O	Input port	INTP3/RTC1HZ/ SCK11/SCL11	Port 3. 2-bit I/O port. Input/output can be specified in 1-bit units. Use of an on-chip pull-up resistor can be specified by a software setting at input port.
P31				TI03/TO03/INTP4/ (PCLBUZ0)	

Notes 1. Digital or analog for each pin can be selected with the port mode control register x (PMCx) (can be set in 1-bit unit).

2. Digital or analog for each pin can be selected with the A/D port configuration register (ADPC).

Remark Functions in parentheses in the above figure can be assigned via settings in the peripheral I/O redirection register (PIOR). Refer to **Figure 4-8 Format of Peripheral I/O Redirection Register (PIOR)**.

(2/4)

Function Name	Pin Type	I/O	After Reset Release	Alternate Function	Function
P40	7-1-1	I/O	Input port	TOOL0	Port 4. 8-bit I/O port. Input/output can be specified in 1-bit units. Use of an on-chip pull-up resistor can be specified by a software setting at input port. Input of P43 and P44 can be set to TTL input buffer. Output of P43 to P45 can be set to N-ch open-drain output (EV _{DD} tolerance).
P41				—	
P42	TI04/TO04				
P43	8-1-2			SCK01/SCL01	
P44				SI01/SDA01	
P45	7-1-2			SO01	
P46	7-1-1			INTP1/TI05/TO05	
P47				INTP2	
P50	7-1-2	I/O	Input port	SI11/SDA11	Port 5. 8-bit I/O port. Input/output can be specified in 1-bit units. Use of an on-chip pull-up resistor can be specified by a software setting at input port. Input of P53 to P55 can be set to TTL input buffer. Output of P50 and P52 to P55 can be set to N-ch open-drain output (EV _{DD} tolerance).
P51	7-1-1			SO11	
P52	7-1-2			SO31	
P53	8-1-2			SI31/SDA31	
P54				SCK31/SCL31	
P55				(PCLBUZ1)/(SCK00)	
P56	7-1-1			(INTP1)	
P57				(INTP3)	
P60	12-1-1	I/O	Input port	SCLA0	Port 6. 8-bit I/O port. Input/output can be specified in 1-bit units. Output of P60 to P63 can be set to N-ch open-drain output (6 V tolerance). For P64 to P67, use of an on-chip pull-up resistor can be specified by a software setting at input port.
P61				SDAA0	
P62	SCLA1				
P63	SDAA1				
P64	7-1-1			TI10/TO10	
P65				TI11/TO11	
P66				TI12/TO12	
P67				TI13/TO13	
P70	7-1-1	I/O	Input port	KR0/SCK21/SCL21	Port 7. 8-bit I/O port. Input/output can be specified in 1-bit units. Use of an on-chip pull-up resistor can be specified by a software setting at input port. Output of P71 and P74 can be set to N-ch open-drain output (EV _{DD} tolerance).
P71	7-1-2			KR1/SI21/SDA21	
P72	7-1-1			KR2/SO21	
P73				KR3	
P74	7-1-2			KR4/INTP8	
P75	7-1-1			KR5/INTP9	
P76				KR6/INTP10/(RxD2)	
P77				KR7/INTP11/(TxD2)	

Remark Functions in parentheses in the above figure can be assigned via settings in the peripheral I/O redirection register (PIOR). Refer to **Figure 4-8 Format of Peripheral I/O Redirection Register (PIOR)**.

(3/4)

Function Name	Pin Type	I/O	After Reset Release	Alternate Function	Function		
P80	8-1-2	I/O	Input port	(SCK10)/(SCL10)	Port 8. 8-bit I/O port. Input/output can be specified in 1-bit units. Use of an on-chip pull-up resistor can be specified by a software setting at input port. Input of P80 and P81 can be set to TTL input buffer. Output of P80 to P82 can be set to N-ch open-drain output (EV _{DD} tolerance).		
P81				(SI10)/(RxD1)/(SDA10)			
P82	7-1-2			(SO10)/(TxD1)			
P83	7-1-1			—			
P84				(INTP6)			
P85				(INTP7)			
P86				(INTP8)			
P87				(INTP9)			
P100	7-3-1	I/O	Analog input port	ANI20	Port 10. 3-bit I/O port. Input/output can be specified in 1-bit units. Use of an on-chip pull-up resistor can be specified by a software setting at input port. P100 can be set to analog input Note .		
P101	7-1-1		Input port	—			
P102			TI06/TO06				
P110	7-1-1	I/O	Input port	(INTP10)	Port 11. 3-bit I/O port. Input/output can be specified in 1-bit units. Use of an on-chip pull-up resistor can be specified by a software setting at input port.		
P111				(INTP11)			
P120	7-3-1	I/O	Analog input port	ANI19	Port 12. 1-bit I/O port and 4-bit input only port. For only P120, input/output can be specified in 1-bit units. For only P120, use of an on-chip pull-up resistor can be specified by a software setting at input port. P120 can be set to analog input Note .		
P121	2-2-1			Input		Input port	X1
P122							X2/EXCLK
P123							XT1
P124							XT2/EXCLKS
P130	1-1-1	Output	Output port	—	Port 13. 1-bit output port and 1-bit input port.		
P137	2-1-2	Input	Input port	INTP0			
P140	7-1-1	I/O	Input port	PCLBUZ0/INTP6	Port 14. 8-bit I/O port. Input/output can be specified in 1-bit units. Use of an on-chip pull-up resistor can be specified by a software setting at input port. Input of P142 and P143 can be set to TTL input buffer. Output of P142 to P144 can be set to N-ch open-drain output (EV _{DD} tolerance). P147 can be set to analog input Note .		
P141						PCLBUZ1/INTP7	
P142	8-1-2			SCK30/SCL30			
P143				SI30/RxD3/SDA30			
P144	7-1-2			SO30/TxD3			
P145	7-1-1			TI07/TO07			
P146				(INTP4)			
P147	7-3-1		Analog input port	ANI18			

Note Digital or analog for each pin can be selected with the port mode control register x (PMCx) (can be set in 1-bit unit).

Remark Functions in parentheses in the above figure can be assigned via settings in the peripheral I/O redirection register (PIOR). Refer to **Figure 4-8 Format of Peripheral I/O Redirection Register (PIOR)**.

(4/4)

Function Name	Pin Type	I/O	After Reset Release	Alternate Function	Function
P150	4-3-1	I/O	Analog input port	ANI8	Port 15. 7-bit I/O port. Input/output can be specified in 1-bit units. Can be set to analog input Note .
P151				ANI9	
P152				ANI10	
P153				ANI11	
P154				ANI12	
P155				ANI13	
P156				ANI14	
$\overline{\text{RESET}}$	2-1-1	Input	—	—	Input only pin for external reset When external reset is not used, connect this pin to V_{DD} directly or via a resistor.

Note Digital or analog for each pin can be selected with the A/D port configuration register (ADPC).

2.1.14 128-pin products

(1/4)

Function Name	Pin Type	I/O	After Reset Release	Alternate Function	Function
P00	7-1-2	I/O	Input port	TI00	Port 0. 8-bit I/O port. Input/output can be specified in 1-bit units. Use of an on-chip pull-up resistor can be specified by a software setting at input port. Input of P01, P03, and P04 can be set to TTL input buffer. Output of P00, P02 to P04 can be set to N-ch open-drain output (EV _{DD} tolerance). P02 and P03 can be set to analog input Note 1 .
P01	8-1-1			TO00	
P02	7-3-2		Analog input port	ANI17/SO10/TxD1	
P03	8-3-2			ANI16/SI10/RxD1/SDA10	
P04	8-1-2		Input port	SCK10/SCL10	
P05	7-1-1			—	
P06				—	
P07				—	
P10	8-1-2	I/O	Input port	SCK00/SCL00/(TI07)/(TO07)	Port 1. 8-bit I/O port. Input/output can be specified in 1-bit units. Use of an on-chip pull-up resistor can be specified by a software setting at input port. Input of P10, P11, and P13 to P17 can be set to TTL input buffer. Output of P10 to P15, and P17 can be set to N-ch open-drain output (EV _{DD} tolerance).
P11				SI00/RxD0/TOOLRxD/SDA00/(TI06)/(TO06)	
P12	7-1-2		SO00/TxD0/TOOLTxD/(INTP5)/(TI05)/(TO05)		
P13	8-1-2		TxD2/SO20/(SDAA0)/(TI04)/(TO04)		
P14			RxD2/SI20/SDA20/(SCLA0)/(TI03)/(TO03)		
P15			SCK20/SCL20/(TI02)/(TO02)		
P16	8-1-1		TI01/TO01/INTP5/(SI00)/(RxD0)		
P17	8-1-2		TI02/TO02/(SO00)/(TxD0)		
P20	4-3-1	I/O	Analog input port	ANI0/AV _{REFP}	Port 2. 8-bit I/O port. Input/output can be specified in 1-bit units. Can be set to analog input Note 2 .
P21				ANI1/AV _{REFM}	
P22				ANI2	
P23				ANI3	
P24				ANI4	
P25				ANI5	
P26				ANI6	
P27				ANI7	

- Notes 1.** Digital or analog for each pin can be selected with the port mode control register x (PMCx) (can be set in 1-bit unit).
- 2.** Digital or analog for each pin can be selected with the A/D port configuration register (ADPC).

Remark Functions in parentheses in the above figure can be assigned via settings in the peripheral I/O redirection register (PIOR). Refer to **Figure 4-8 Format of Peripheral I/O Redirection Register (PIOR)**.

(2/4)

Function Name	Pin Type	I/O	After Reset Release	Alternate Function	Function
P30	7-1-1	I/O	Input port	INTP3/RTC1HZ	Port 3. 8-bit I/O port. Input/output can be specified in 1-bit units. Use of an on-chip pull-up resistor can be specified by a software setting at input port. P35 to P37 can be set to analog input Note .
P31				TI03/TO03/INTP4/ (PCLBUZ0)	
P32				—	
P33				—	
P34				—	
P35	7-3-1	I/O	Analog input port	ANI23	
P36				ANI22	
P37				ANI21	
P40	7-1-1	I/O	Input port	TOOL0	Port 4. 8-bit I/O port. Input/output can be specified in 1-bit units. Use of an on-chip pull-up resistor can be specified by a software setting at input port.
P41				—	
P42	8-1-2	I/O	Input port	TI04/TO04	Input of P43 and P44 can be set to TTL input buffer. Output of P43 to P45 can be set to N-ch open-drain output (EV _{DD} tolerance).
P43				SCK01/SCL01	
P44				SI01/SDA01	
P45	7-1-2	I/O	Input port	SO01	
P46	7-1-1			INTP1/TI05/TO05	
P47	7-1-1			INTP2	
P50	7-1-2	I/O	Input port	—	Port 5. 8-bit I/O port. Input/output can be specified in 1-bit units. Use of an on-chip pull-up resistor can be specified by a software setting at input port. Input of P53 to P55 can be set to TTL input buffer. Output of P50 and P52 to P55 can be set to N-ch open-drain output (EV _{DD} tolerance).
P51	7-1-1			—	
P52	7-1-2			SO31	
P53	8-1-2			SI31/SDA31	
P54				SCK31/SCL31	
P55	(PCLBUZ1)/(SCK00)				
P56	7-1-1			(INTP1)	
P57	7-1-1	(INTP3)			
P60	12-1-1	I/O	Input port	SCLA0	Port 6. 8-bit I/O port. Input/output can be specified in 1-bit units. Output of P60 to P63 can be set to N-ch open-drain output (6 V tolerance). For P64 to P67, use of an on-chip pull-up resistor can be specified by a software setting at input port.
P61				SDAA0	
P62				SCLA1	
P63	7-1-1	I/O	Input port	SDAA1	
P64				TI10/TO10	
P65				TI11/TO11	
P66				TI12/TO12	
P67	7-1-1	I/O	Input port	TI13/TO13	

Note Digital or analog for each pin can be selected with the port mode control register x (PMCx) (can be set in 1-bit unit).

Remark Functions in parentheses in the above figure can be assigned via settings in the peripheral I/O redirection register (PIOR). Refer to **Figure 4-8 Format of Peripheral I/O Redirection Register (PIOR)**.

(3/4)

Function Name	Pin Type	I/O	After Reset Release	Alternate Function	Function	
P70	7-1-1	I/O	Input port	KR0/SCK21/SCL21	Port 7. 8-bit I/O port. Input/output can be specified in 1-bit units. Use of an on-chip pull-up resistor can be specified by a software setting at input port. Output of P71 and P74 can be set to N-ch open-drain output (EV _{DD} tolerance).	
P71	7-1-2			KR1/SI21/SDA21		
P72	7-1-1			KR2/SO21		
P73				KR3		
P74	7-1-2			KR4/INTP8		
P75	7-1-1			KR5/INTP9		
P76				KR6/INTP10/(RxD2)		
P77				KR7/INTP11/(TxD2)		
P80	8-1-2	I/O	Input port	(SCK10)/(SCL10)	Port 8. 8-bit I/O port. Input/output can be specified in 1-bit units. Use of an on-chip pull-up resistor can be specified by a software setting at input port. Input of P80 and P81 can be set to TTL input buffer. Output of P80 to P82 can be set to N-ch open-drain output (EV _{DD} tolerance).	
P81				(SI10)/(RxD1)/(SDA10)		
P82	7-1-2			(SO10)/(TxD1)		
P83	7-1-1			—		
P84				(INTP6)		
P85				(INTP7)		
P86				(INTP8)		
P87				(INTP9)		
P90	7-1-1			I/O		Input port
P91		—				
P92		—				
P93		—				
P94		—				
P95			SCK11/SCL11			
P96		7-1-2	SI11/SDA11			
P97		7-1-1	SO11			
P100	7-3-1	I/O	Analog input port	ANI20	Port 10. 7-bit I/O port. Input/output can be specified in 1-bit units. Use of an on-chip pull-up resistor can be specified by a software setting at input port. P100 can be set to analog input Note .	
P101	7-1-1		Input port	—		
P102				TI06/TO06		
P103				TI14/TO14		
P104				TI15/TO15		
P105				TI16/TO16		
P106				TI17/TO17		

Note Digital or analog for each pin can be selected with the port mode control register x (PMCx) (can be set in 1-bit unit).

Remark Functions in parentheses in the above figure can be assigned via settings in the peripheral I/O redirection register (PIOR). Refer to **Figure 4-8 Format of Peripheral I/O Redirection Register (PIOR)**.

(4/4)

Function Name	Pin Type	I/O	After Reset Release	Alternate Function	Function
P110	7-1-1	I/O	Input port	(INTP10)	Port 11. 8-bit I/O port. Input/output can be specified in 1-bit units. Use of an on-chip pull-up resistor can be specified by a software setting at input port. P115 to P117 can be set to analog input Note 1 .
P111				(INTP11)	
P112				—	
P113				—	
P114				—	
P115	7-3-1		Analog input port	ANI26	
P116				ANI25	
P117				ANI24	
P120	7-3-1	I/O	Analog input port	ANI19	Port 12. 4-bit I/O port and 4-bit input port.
P121	2-2-1	Input	Input port	X1	For only P120, P125 to P127, input/output can be specified in 1-bit units. For only P120, P125 to P127, use of an on-chip pull-up resistor can be specified by a software setting. at input port.
P122				X2/EXCLK	
P123				XT1	
P124				XT2/EXCLKS	
P125	7-1-1	I/O		—	P120 can be set to analog input Note 1 .
P126				—	
P127				—	
P130	1-1-1	Output	Output port	—	Port 13.
P137	2-1-2	Input	Input port	INTP0	1-bit output port and 1-bit input port.
P140	7-1-1	I/O	Input port	PCLBUZ0/INTP6	Port 14. 8-bit I/O port. Input/output can be specified in 1-bit units. Use of an on-chip pull-up resistor can be specified by a software setting. at input port at input port.
P141				PCLBUZ1/INTP7	
P142	8-1-2			SCK30/SCL30	Input of P142 and P143 can be set to TTL input buffer. Output of P142 to P144 can be set to N-ch open-drain output (EV _{DD} tolerance). P147 can be set to analog input Note 1 .
P143				SI30/RxD3/SDA30	
P144	7-1-2			SO30/TxD3	
P145	7-1-1			TI07/TO07	
P146				(INTP4)	
P147	7-3-1		Analog input port	ANI18	
P150	4-3-1	I/O	Analog input port	ANI8	Port 15. 7-bit I/O port. Input/output can be specified in 1-bit units. Can be set to analog input Note 2 .
P151				ANI9	
P152				ANI10	
P153				ANI11	
P154				ANI12	
P155				ANI13	
P156				ANI14	
$\overline{\text{RESET}}$	2-1-1	Input	—	—	Input only pin for external reset When external reset is not used, connect this pin to V _{DD} directly or via a resistor.

Notes 1. Digital or analog for each pin can be selected with the port mode control register x (PMCx) (can be set in 1-bit unit).

2. Digital or analog for each pin can be selected with the A/D port configuration register (ADPC).

Remark Functions in parentheses in the above figure can be assigned via settings in the peripheral I/O redirection register (PIOR). Refer to **Figure 4-8 Format of Peripheral I/O Redirection Register (PIOR)**.

2.2 Functions other than port pins

2.2.1 Functions for each product

(1/5)

Function Name	128-pin	100-pin	80-pin	64-pin	52-pin	48-pin	44-pin	40-pin	36-pin	32-pin	30-pin	25-pin	24-pin	20-pin
ANI0	√	√	√	√	√	√	√	√	√	√	√	√	√	√
ANI1	√	√	√	√	√	√	√	√	√	√	√	√	√	√
ANI2	√	√	√	√	√	√	√	√	√	√	√	√	√	√
ANI3	√	√	√	√	√	√	√	√	√	√	√	-	-	-
ANI4	√	√	√	√	√	√	√	√	√	-	-	-	-	-
ANI5	√	√	√	√	√	√	√	√	√	-	-	-	-	-
ANI6	√	√	√	√	√	√	√	√	-	-	-	-	-	-
ANI7	√	√	√	√	√	√	√	-	-	-	-	-	-	-
ANI8	√	√	√	-	-	-	-	-	-	-	-	-	-	-
ANI9	√	√	√	-	-	-	-	-	-	-	-	-	-	-
ANI10	√	√	√	-	-	-	-	-	-	-	-	-	-	-
ANI11	√	√	√	-	-	-	-	-	-	-	-	-	-	-
ANI12	√	√	-	-	-	-	-	-	-	-	-	-	-	-
ANI13	√	√	-	-	-	-	-	-	-	-	-	-	-	-
ANI14	√	√	-	-	-	-	-	-	-	-	-	-	-	-
ANI16	√	√	√	√	√	-	-	-	-	√	√	√	√	√
ANI17	√	√	√	√	√	-	-	-	-	√	√	√	√	√
ANI18	√	√	√	√	√	√	√	√	√	√	√	√	√	√
ANI19	√	√	√	√	√	√	√	√	√	√	√	-	-	-
ANI20	√	√	√	-	-	-	-	-	-	-	-	-	-	-
ANI21	√	-	-	-	-	-	-	-	-	-	-	-	-	-
ANI22	√	-	-	-	-	-	-	-	-	-	-	-	-	-
ANI23	√	-	-	-	-	-	-	-	-	-	-	-	-	-
ANI24	√	-	-	-	-	-	-	-	-	-	-	-	-	-
ANI25	√	-	-	-	-	-	-	-	-	-	-	-	-	-
ANI26	√	-	-	-	-	-	-	-	-	-	-	-	-	-
INTP0	√	√	√	√	√	√	√	√	√	√	√	√	√	√
INTP1	√	√	√	√	√	√	√	√	√	√	√	√	√	-
INTP2	√	√	√	√	√	√	√	√	√	√	√	-	-	-
INTP3	√	√	√	√	√	√	√	√	√	√	√	√	√	√
INTP4	√	√	√	√	√	√	√	√	√	√	√	√	√	-
INTP5	√	√	√	√	√	√	√	√	√	√	√	√	√	√
INTP6	√	√	√	√	√	√	-	-	-	-	-	-	-	-
INTP7	√	√	√	√	-	-	-	-	-	-	-	-	-	-
INTP8	√	√	√	√	√	√	-	-	-	-	-	-	-	-
INTP9	√	√	√	√	√	√	-	-	-	-	-	-	-	-
INTP10	√	√	√	√	√	-	-	-	-	-	-	-	-	-
INTP11	√	√	√	√	√	-	-	-	-	-	-	-	-	-

(2/5)

Function Name	128-pin	100-pin	80-pin	64-pin	52-pin	48-pin	44-pin	40-pin	36-pin	32-pin	30-pin	25-pin	24-pin	20-pin
KR0	√	√	√	√	√	√	√	√	-	-	-	-	-	-
KR1	√	√	√	√	√	√	√	√	-	-	-	-	-	-
KR2	√	√	√	√	√	√	√	√	-	-	-	-	-	-
KR3	√	√	√	√	√	√	√	√	-	-	-	-	-	-
KR4	√	√	√	√	√	√	-	-	-	-	-	-	-	-
KR5	√	√	√	√	√	√	-	-	-	-	-	-	-	-
KR6	√	√	√	√	√	-	-	-	-	-	-	-	-	-
KR7	√	√	√	√	√	-	-	-	-	-	-	-	-	-
PCLBUZ0	√	√	√	√	√	√	√	√	√	√	√	√	√	-
PCLBUZ1	√	√	√	√	√	√	√	√	√	√	√	-	-	-
REGC	√	√	√	√	√	√	√	√	√	√	√	√	√	√
RTC1HZ	√	√	√	√	√	√	√	√	-	-	-	-	-	-
RESET	√	√	√	√	√	√	√	√	√	√	√	√	√	√
RxD0	√	√	√	√	√	√	√	√	√	√	√	√	√	√
RxD1	√	√	√	√	√	√	√	√	√	√	√	√	√	√
RxD2	√	√	√	√	√	√	√	√	√	√	√	-	-	-
RxD3	√	√	√	-	-	-	-	-	-	-	-	-	-	-
TxD0	√	√	√	√	√	√	√	√	√	√	√	√	√	√
TxD1	√	√	√	√	√	√	√	√	√	√	√	√	√	√
TxD2	√	√	√	√	√	√	√	√	√	√	√	-	-	-
TxD3	√	√	√	-	-	-	-	-	-	-	-	-	-	-
SCK00	√	√	√	√	√	√	√	√	√	√	√	√	√	√
SCK01	√	√	√	√	√	√	-	-	-	-	-	-	-	-
SCK10	√	√	√	√	-	-	-	-	-	-	-	-	-	-
SCK11	√	√	√	√	√	√	√	√	√	√	√	√	√	√
SCK20	√	√	√	√	√	√	√	√	√	√	√	-	-	-
SCK21	√	√	√	√	√	√	√	√	√	-	-	-	-	-
SCK30	√	√	√	-	-	-	-	-	-	-	-	-	-	-
SCK31	√	√	√	-	-	-	-	-	-	-	-	-	-	-
SCL00	√	√	√	√	√	√	√	√	√	√	√	√	√	√
SCL01	√	√	√	√	√	√	-	-	-	-	-	-	-	-
SCL10	√	√	√	√	-	-	-	-	-	-	-	-	-	-
SCL11	√	√	√	√	√	√	√	√	√	√	√	√	√	√
SCL20	√	√	√	√	√	√	√	√	√	√	√	-	-	-
SCL21	√	√	√	√	√	√	√	√	√	-	-	-	-	-
SCL30	√	√	√	-	-	-	-	-	-	-	-	-	-	-
SCL31	√	√	√	-	-	-	-	-	-	-	-	-	-	-

(3/5)

Function Name	128-pin	100-pin	80-pin	64-pin	52-pin	48-pin	44-pin	40-pin	36-pin	32-pin	30-pin	25-pin	24-pin	20-pin
SDA00	√	√	√	√	√	√	√	√	√	√	√	√	√	√
SDA01	√	√	√	√	√	√	–	–	–	–	–	–	–	–
SDA10	√	√	√	√	–	–	–	–	–	–	–	–	–	–
SDA11	√	√	√	√	√	√	√	√	√	√	√	√	√	√
SDA20	√	√	√	√	√	√	√	√	√	√	√	–	–	–
SDA21	√	√	√	√	√	√	√	√	√	–	–	–	–	–
SDA30	√	√	√	–	–	–	–	–	–	–	–	–	–	–
SDA31	√	√	√	–	–	–	–	–	–	–	–	–	–	–
SI00	√	√	√	√	√	√	√	√	√	√	√	√	√	√
SI01	√	√	√	√	√	√	–	–	–	–	–	–	–	–
SI10	√	√	√	√	–	–	–	–	–	–	–	–	–	–
SI11	√	√	√	√	√	√	√	√	√	√	√	√	√	√
SI20	√	√	√	√	√	√	√	√	√	√	√	–	–	–
SI21	√	√	√	√	√	√	√	√	√	–	–	–	–	–
SI30	√	√	√	–	–	–	–	–	–	–	–	–	–	–
SI31	√	√	√	–	–	–	–	–	–	–	–	–	–	–
SO00	√	√	√	√	√	√	√	√	√	√	√	√	√	√
SO01	√	√	√	√	√	√	–	–	–	–	–	–	–	–
SO10	√	√	√	√	–	–	–	–	–	–	–	–	–	–
SO11	√	√	√	√	√	√	√	√	√	√	√	√	√	√
SO20	√	√	√	√	√	√	√	√	√	√	√	–	–	–
SO21	√	√	√	√	√	√	√	√	√	–	–	–	–	–
SO30	√	√	√	–	–	–	–	–	–	–	–	–	–	–
SO31	√	√	√	–	–	–	–	–	–	–	–	–	–	–
SCLA0	√	√	√	√	√	√	√	√	√	√	√	√	√	–
SCLA1	√	√	√	–	–	–	–	–	–	–	–	–	–	–
SDAA0	√	√	√	√	√	√	√	√	√	√	√	√	√	–
SDAA1	√	√	√	–	–	–	–	–	–	–	–	–	–	–
TI00	√	√	√	√	√	√	√	√	√	√	√	√	√	√
TI01	√	√	√	√	√	√	√	√	√	√	√	√	√	√
TI02	√	√	√	√	√	√	√	√	√	√	√	√	√	√
TI03	√	√	√	√	√	√	√	√	√	√	√	√	√	–
TI04	√	√	√	√	(√)	(√)	(√)	(√)	(√)	(√)	(√)	–	–	–
TI05	√	√	√	√	(√)	(√)	(√)	(√)	(√)	(√)	(√)	–	–	–
TI06	√	√	√	√	(√)	(√)	(√)	(√)	(√)	(√)	(√)	–	–	–
TI07	√	√	√	√	√	√	√	(√)	(√)	(√)	(√)	–	–	–

Remark The checked function is available only when the bit corresponding to the function in the peripheral I/O redirection register (PIOR) is set to 1.

(4/5)

Function Name	128-pin	100-pin	80-pin	64-pin	52-pin	48-pin	44-pin	40-pin	36-pin	32-pin	30-pin	25-pin	24-pin	20-pin
TI10	√	√	√	–	–	–	–	–	–	–	–	–	–	–
TI11	√	√	√	–	–	–	–	–	–	–	–	–	–	–
TI12	√	√	√	–	–	–	–	–	–	–	–	–	–	–
TI13	√	√	√	–	–	–	–	–	–	–	–	–	–	–
TI14	√	–	–	–	–	–	–	–	–	–	–	–	–	–
TI15	√	–	–	–	–	–	–	–	–	–	–	–	–	–
TI16	√	–	–	–	–	–	–	–	–	–	–	–	–	–
TI17	√	–	–	–	–	–	–	–	–	–	–	–	–	–
TO00	√	√	√	√	√	√	√	√	√	√	√	√	√	√
TO01	√	√	√	√	√	√	√	√	√	√	√	√	√	√
TO02	√	√	√	√	√	√	√	√	√	√	√	√	√	√
TO03	√	√	√	√	√	√	√	√	√	√	√	√	√	–
TO04	√	√	√	√	(√)	(√)	(√)	(√)	(√)	(√)	(√)	–	–	–
TO05	√	√	√	√	(√)	(√)	(√)	(√)	(√)	(√)	(√)	–	–	–
TO06	√	√	√	√	(√)	(√)	(√)	(√)	(√)	(√)	(√)	–	–	–
TO07	√	√	√	√	√	√	√	(√)	(√)	(√)	(√)	–	–	–
TO10	√	√	√	–	–	–	–	–	–	–	–	–	–	–
TO11	√	√	√	–	–	–	–	–	–	–	–	–	–	–
TO12	√	√	√	–	–	–	–	–	–	–	–	–	–	–
TO13	√	√	√	–	–	–	–	–	–	–	–	–	–	–
TO14	√	–	–	–	–	–	–	–	–	–	–	–	–	–
TO15	√	–	–	–	–	–	–	–	–	–	–	–	–	–
TO16	√	–	–	–	–	–	–	–	–	–	–	–	–	–
TO17	√	–	–	–	–	–	–	–	–	–	–	–	–	–
X1	√	√	√	√	√	√	√	√	√	√	√	√	√	√
X2	√	√	√	√	√	√	√	√	√	√	√	√	√	√
EXCLK	√	√	√	√	√	√	√	√	√	√	√	√	√	√
XT1	√	√	√	√	√	√	√	√	–	–	–	–	–	–
XT2	√	√	√	√	√	√	√	√	–	–	–	–	–	–
EXCLKS	√	√	√	√	√	√	√	√	–	–	–	–	–	–

Remark The checked function is available only when the bit corresponding to the function in the peripheral I/O redirection register (PIOR) is set to 1.

(5/5)

Function Name	128-pin	100-pin	80-pin	64-pin	52-pin	48-pin	44-pin	40-pin	36-pin	32-pin	30-pin	25-pin	24-pin	20-pin
V _{DD}	√	√	√	√	√	√	√	√	√	√	√	√	√	√
EV _{DD0}	√	√	√	√	–	–	–	–	–	–	–	–	–	–
EV _{DD1}	√	√	–	–	–	–	–	–	–	–	–	–	–	–
AV _{REFP}	√	√	√	√	√	√	√	√	√	√	√	√	√	√
AV _{REFM}	√	√	√	√	√	√	√	√	√	√	√	√	√	√
V _{SS}	√	√	√	√	√	√	√	√	√	√	√	√	√	√
EV _{SS0}	√	√	√	√	–	–	–	–	–	–	–	–	–	–
EV _{SS1}	√	√	–	–	–	–	–	–	–	–	–	–	–	–
TOOL _{RxD}	√	√	√	√	√	√	√	√	√	√	√	√	√	√
TOOL _{TxD}	√	√	√	√	√	√	√	√	√	√	√	√	√	√
TOOL ₀	√	√	√	√	√	√	√	√	√	√	√	√	√	√

Remark The checked function is available only when the bit corresponding to the function in the peripheral I/O redirection register (PIOR) is set to 1.

2.2.2 Pins for each product (pins other than port pins)

(1/2)

Function Name	I/O	Function
ANI0 to ANI14, ANI16 to ANI26	Input	A/D converter analog input (see Figure 11-44 Analog Input Pin Connection)
INTP0 to INTP11	Input	External interrupt request input pin for which the valid edge (rising edge, falling edge, or both rising and falling edges) can be specified.
KR0 to KR7	Input	Key interrupt input
PCLBUZ0, PCLBUZ1	Output	Clock output/buzzer output
REGC	–	Pin for connecting regulator output stabilization capacitance for internal operation. Connect this pin to V _{SS} via a capacitor (0.47 to 1 μF). Also, use a capacitor with good characteristics, since it is used to stabilize internal voltage.
RTC1HZ	Output	Real-time clock correction clock (1 Hz) output
RESET	Input	This is the active-low system reset input pin. When the external reset pin is not used, connect this pin directly or via a resistor to V _{DD} .
RxD0 to RxD3	Input	Serial data input pins of serial interfaces UART0, UART1, UART2, and UART3
TxD0 to TxD3	Output	Serial data output pins of serial interfaces UART0, UART1, UART2, and UART3
SCK00, SCK01, SCK10, SCK11, SCK20, SCK21, SCK30, SCK31	I/O	Serial clock I/O pins of serial interface CSI00, CSI01, CSI10, CSI11, CSI20, CSI21, CSI30, and CSI31
SCL00, SCL01, SCL10, SCL11, SCL20, SCL21, SCL30, SCL31	Output	Serial clock output pins of serial interface IIC00, IIC01, IIC10, IIC11, IIC20, IIC21, IIC30, IIC31
SDA00, SDA01, SDA10, SDA11, SDA20, SDA21, SDA30, SDA31	I/O	Serial data I/O pins of serial interface IIC00, IIC01, IIC10, IIC11, IIC20, IIC21, IIC30, IIC31
SI00, SI01, SI10, SI11, SI20, SI21, SI30, SI31	Input	Serial data input pins of serial interface CSI00, CSI01, CSI10, CSI11, CSI20, CSI21, CSI30, and CSI31
SO00, SO01, SO10, SO11, SO20, SO21, SO30, SO31	Output	Serial data output pins of serial interface CSI00, CSI01, CSI10, CSI11, CSI20, CSI21, CSI30, and CSI31
SCLA0, SCLA1	I/O	Serial clock I/O pins of serial interface IICA0, IICA1
SDAA0, SDAA1	I/O	Serial data I/O pins of serial interface IICA0, IICA1
TI00 to TI07, TI10 to TI17	Input	The pins for inputting an external count clock/capture trigger to 16-bit timers 00 to 07, 10 to 17
TO00 to TO07, TO10 to TO17	Output	Timer output pins of 16-bit timers 00 to 07, 10 to 17
X1, X2	–	Resonator connection for main system clock
EXCLK	Input	External clock input for main system clock
XT1, XT2	–	Resonator connection for subsystem clock
EXCLKS	Input	External clock input for subsystem clock

Remark Functions in parentheses in the above figure can be assigned via settings in the peripheral I/O redirection register (PIOR).

(2/2)

Function Name	I/O	Function
V _{DD}	–	<20-pin, 24-pin, 25-pin, 30-pin, 32-pin, 36-pin, 40-pin, 44-pin, 48-pin, 52-pin> Positive power supply for all pins <64-pin, 80-pin, 100-pin, 128-pin > Positive power supply for P20 to P27, P121 to P124, P137, P150 to P156 and other than ports
EV _{DD0} , EV _{DD1}	–	Positive power supply for ports (other than P20 to P27, P121 to P124, P137, P150 to P156)
AV _{REFP}	Input	A/D converter reference potential (+ side) input
AV _{REFM}	Input	A/D converter reference potential (– side) input
V _{SS}	–	<20-pin, 24-pin, 25-pin, 30-pin, 32-pin, 36-pin, 40-pin, 44-pin, 48-pin, 52-pin > Ground potential for all pins <64-pin, 80-pin, 100-pin, 128-pin > Ground potential for P20 to P27, P121 to P124, P137, P150 to P156 and other than ports
EV _{SS0} , EV _{SS1}	–	Ground potential for ports (other than P20 to P27, P121 to P124, P137, P150 to P156)
TOOLRxD	Input	UART reception pin for the external device connection used during flash memory programming
TOOLTxD	Output	UART transmission pin for the external device connection used during flash memory programming
TOOL0	I/O	Data I/O for flash memory programmer/debugger

Caution After reset release, the relationships between P40/TOOL0 and the operating mode are as follows.

Table 2-2. Relationships Between P40/TOOL0 and Operation Mode After Reset Release

P40/TOOL0	Operating mode
EV _{DD}	Normal operation mode
0 V	Flash memory programming mode

For details, see 25.4 Serial Programming Method.

Remark Use bypass capacitors (about 0.1 μF) as noise and latch up countermeasures with relatively thick wires at the shortest distance to V_{DD} to V_{SS}, EV_{DD0} to EV_{SS0} and EV_{DD1} to EV_{SS1} lines.

2.3 Connection of Unused Pins

Table 2-3 shows the connections of unused pins.

Remark The pins mounted depend on the product. Refer to **1.3 Pin Configuration (Top View)** and **2.1 Port Function**.

Table 2-3. Connections of Unused Pins

Pin Name	I/O	Recommended Connection of Unused Pins
P00 to P07	I/O	Input: Independently connect to EV_{DD0} , EV_{DD1} or EV_{SS0} , EV_{SS1} via a resistor. Output: Leave open.
P10 to P17		
P20 to P27		Input: Independently connect to V_{DD} or V_{SS} via a resistor. Output: Leave open.
P30 to P37		Input: Independently connect to EV_{DD0} , EV_{DD1} or EV_{SS0} , EV_{SS1} via a resistor. Output: Leave open.
P40/TOOL0		Input: Independently connect to EV_{DD0} , EV_{DD1} or leave open. Output: Leave open.
P41 to P47		Input: Independently connect to EV_{DD0} , EV_{DD1} or EV_{SS0} , EV_{SS1} via a resistor. Output: Leave open.
P50 to P57		Input: Independently connect to EV_{DD0} , EV_{DD1} or EV_{SS0} , EV_{SS1} via a resistor. Output: Set the port's output latch to 0 and leave the pins open, or set the port's output latch to 1 and independently connect the pins to EV_{DD0} and EV_{DD1} or EV_{SS0} and EV_{SS1} via a resistor.
P60 to P63		
P64 to P67		Input: Independently connect to EV_{DD0} , EV_{DD1} or EV_{SS0} , EV_{SS1} via a resistor. Output: Leave open.
P70 to P77		
P80 to P87		
P90 to P97		
P100 to P106		
P110 to P117		
P120		
P121 to P124	Input	Independently connect to V_{DD} or V_{SS} via a resistor.
P125 to P127	I/O	Input: Independently connect to EV_{DD0} , EV_{DD1} or EV_{SS0} , EV_{SS1} via a resistor. Output: Leave open.
P130	Output	Leave open.
P137	Input	Independently connect to V_{DD} or V_{SS} via a resistor.
P140 to P147	I/O	Input: Independently connect to EV_{DD0} , EV_{DD1} or EV_{SS0} , EV_{SS1} via a resistor. Output: Leave open.
P150 to P156	I/O	Input: Independently connect to V_{DD} or V_{SS} via a resistor. Output: Leave open.
RESET	Input	Connect directly or via a resistor to V_{DD} .
REGC	—	Connect to V_{SS} via capacitor (0.47 to 1 μ F).

Remark For the products that do not have an EV_{DD0} , EV_{DD1} , EV_{SS0} , or EV_{SS1} pin, replace EV_{DD0} and EV_{DD1} with V_{DD} , and replace EV_{SS0} and EV_{SS1} with V_{SS} .

2.4 Block Diagrams of Pins

Figures 2-1 to 2-14 show the block diagrams of the pins described in 2.1.1 20-pin products to 2.1.14 128-pin products.

Figure 2-1. Pin Block Diagram for Pin Type 1-1-1

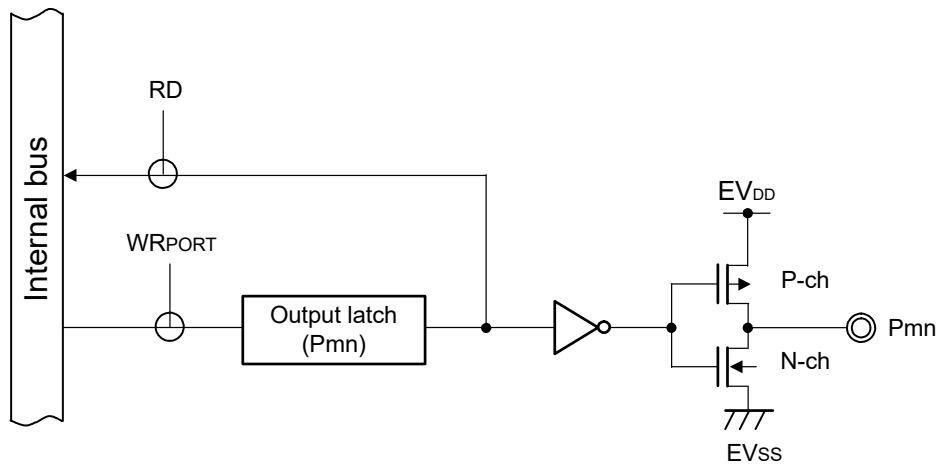

Figure 2-2. Pin Block Diagram for Pin Type 2-1-1

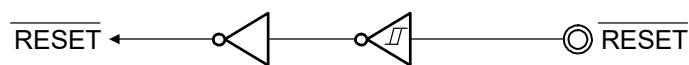
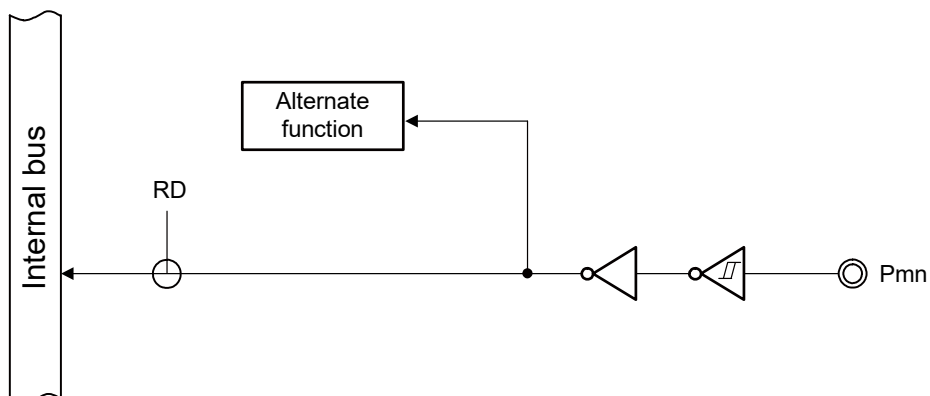
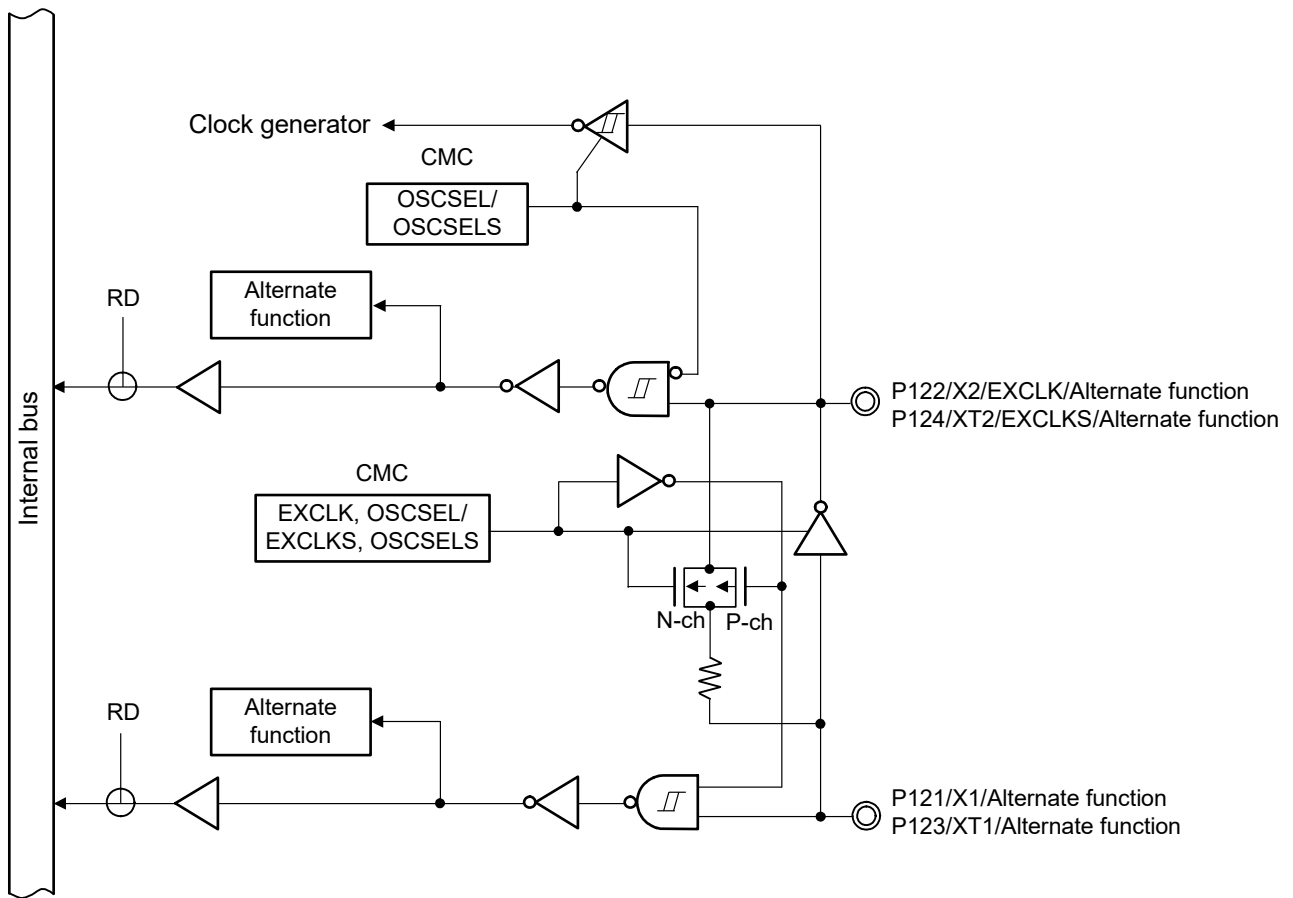

Figure 2-3. Pin Block Diagram for Pin Type 2-1-2



Remark For alternate functions, see 2.1 Port Function.

Figure 2-4. Pin Block Diagram for Pin Type 2-2-1



Remark For alternate functions, see 2.1 Port Function.

Figure 2-5. Pin Block Diagram for Pin Type 4-3-1

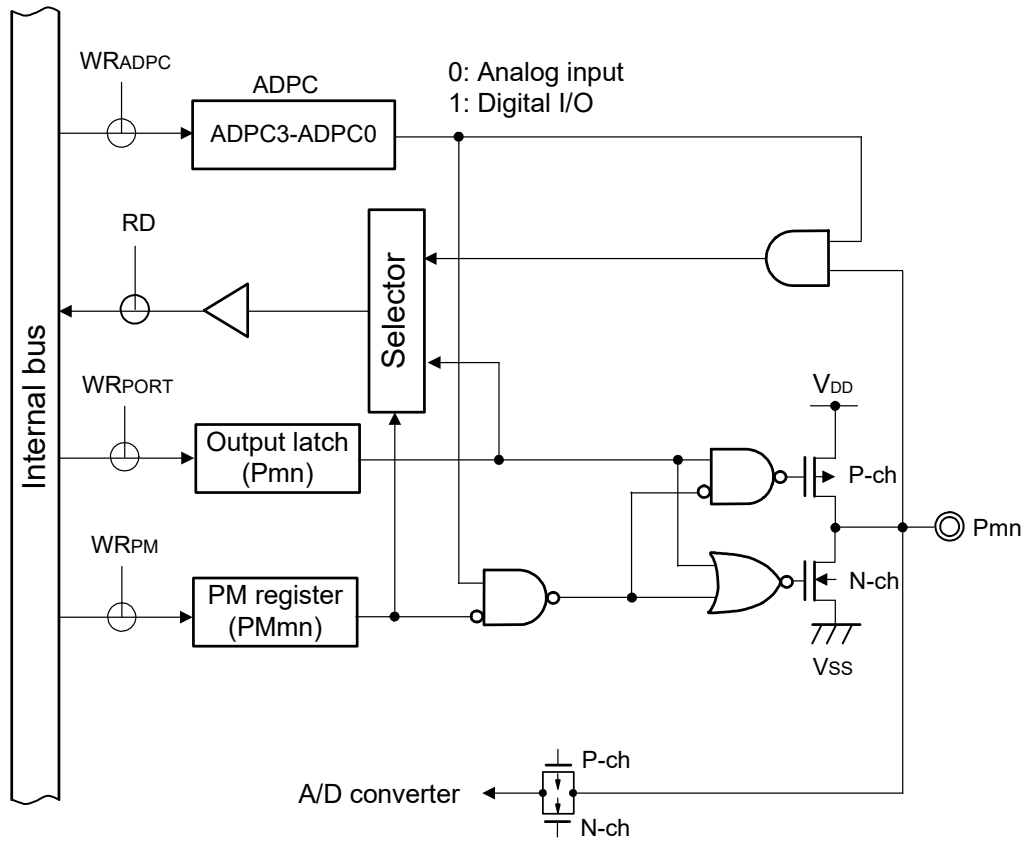
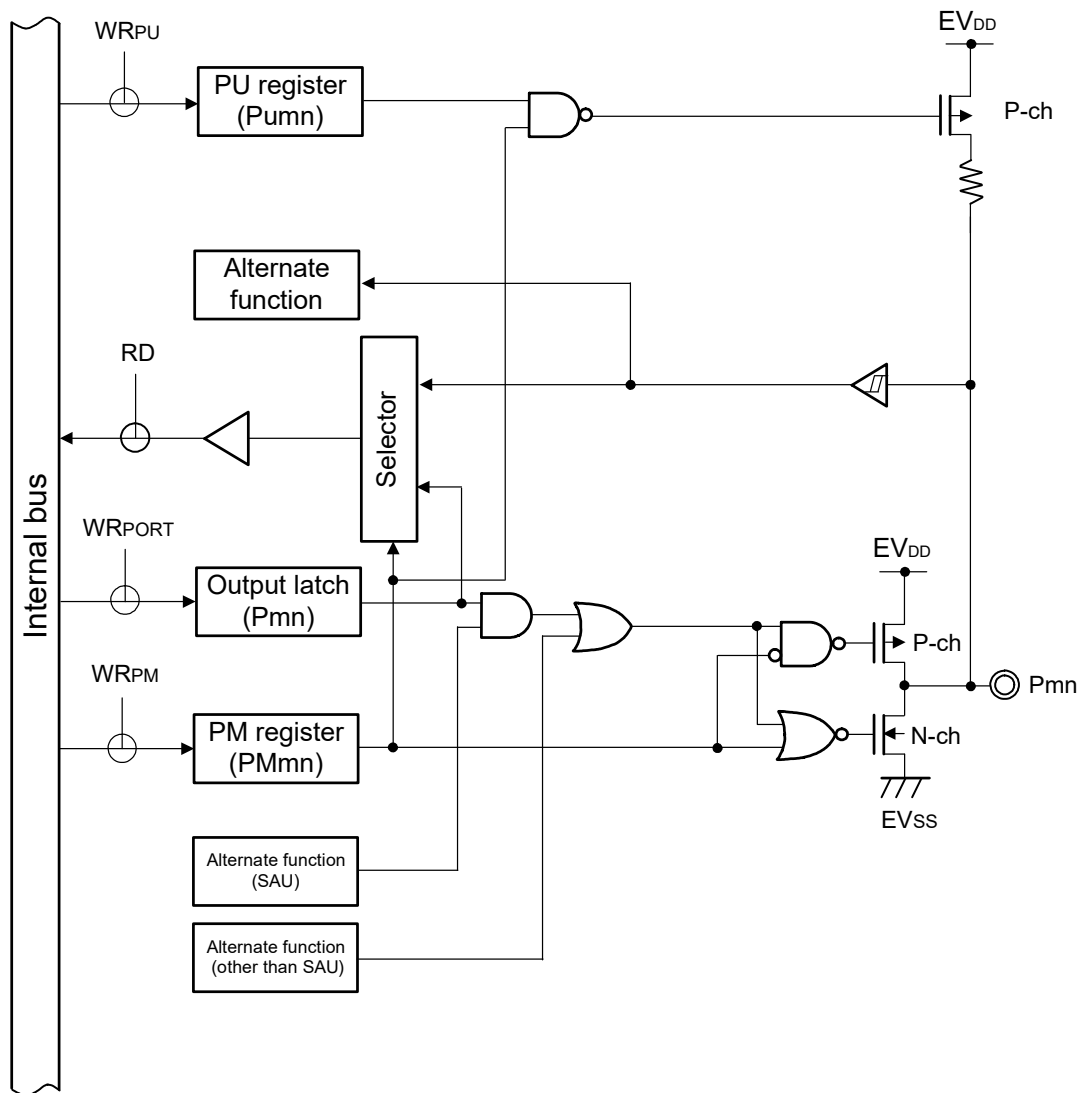
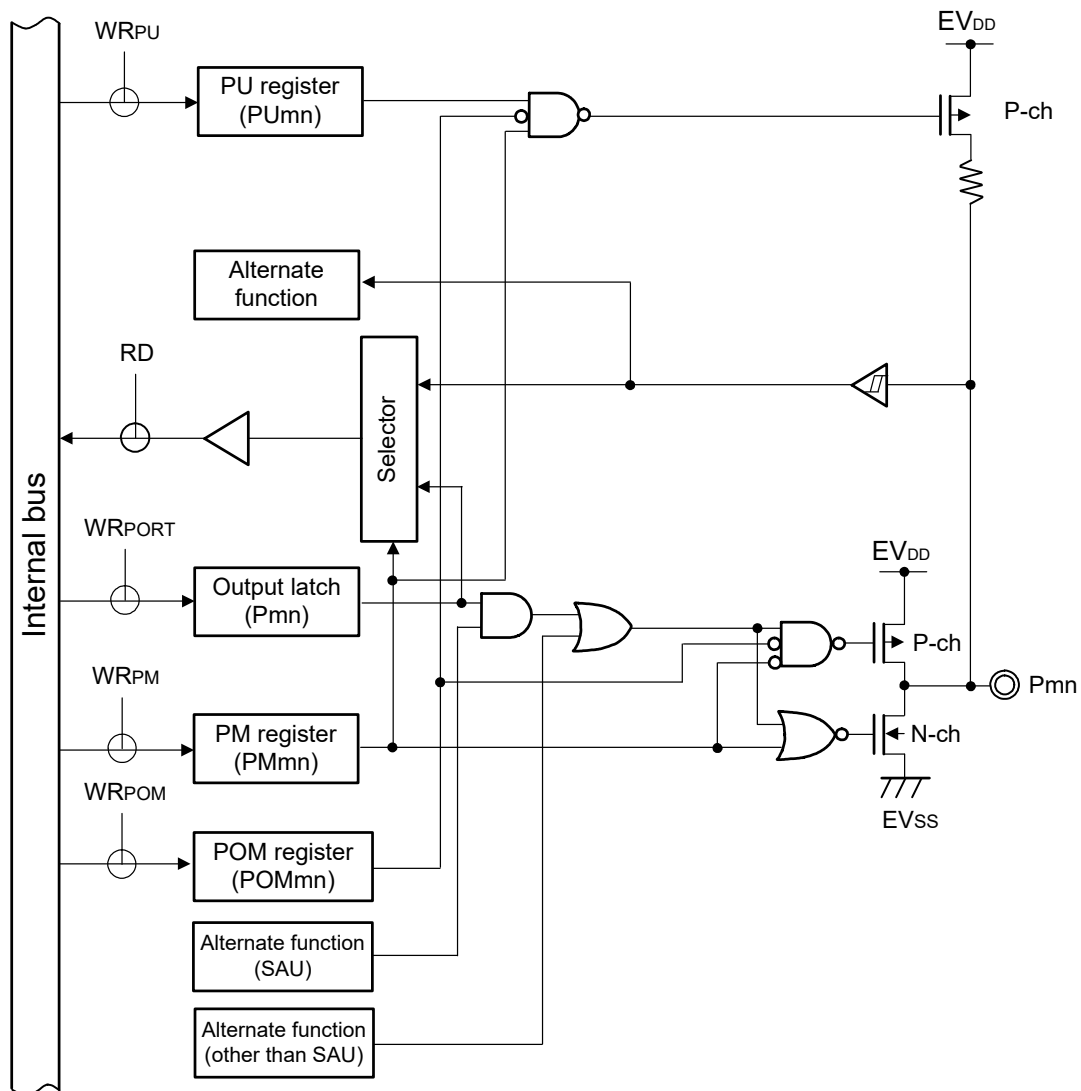

Figure 2-6. Pin Block Diagram for Pin Type 7-1-1



- Remarks**
1. For alternate functions, see 2.1 Port Function.
 2. SAU: Serial array unit

Figure 2-7. Pin Block Diagram for Pin Type 7-1-2



Caution The input buffer is enabled even if the type 7-1-2 pin is operating as an output when the N-ch open drain output mode is selected by the corresponding bit in the port output mode register (POMxx). This may lead to a through current flowing through the type 7-1-2 pin when the voltage level on this pin is intermediate. Changing the output level when the N-ch open drain output mode is selected may cause a glitch (EV_{DD} level).

- Remarks**
1. For alternate functions, see 2.1 Port Function.
 2. SAU: Serial array unit

Figure 2-8. Pin Block Diagram for Pin Type 7-3-1

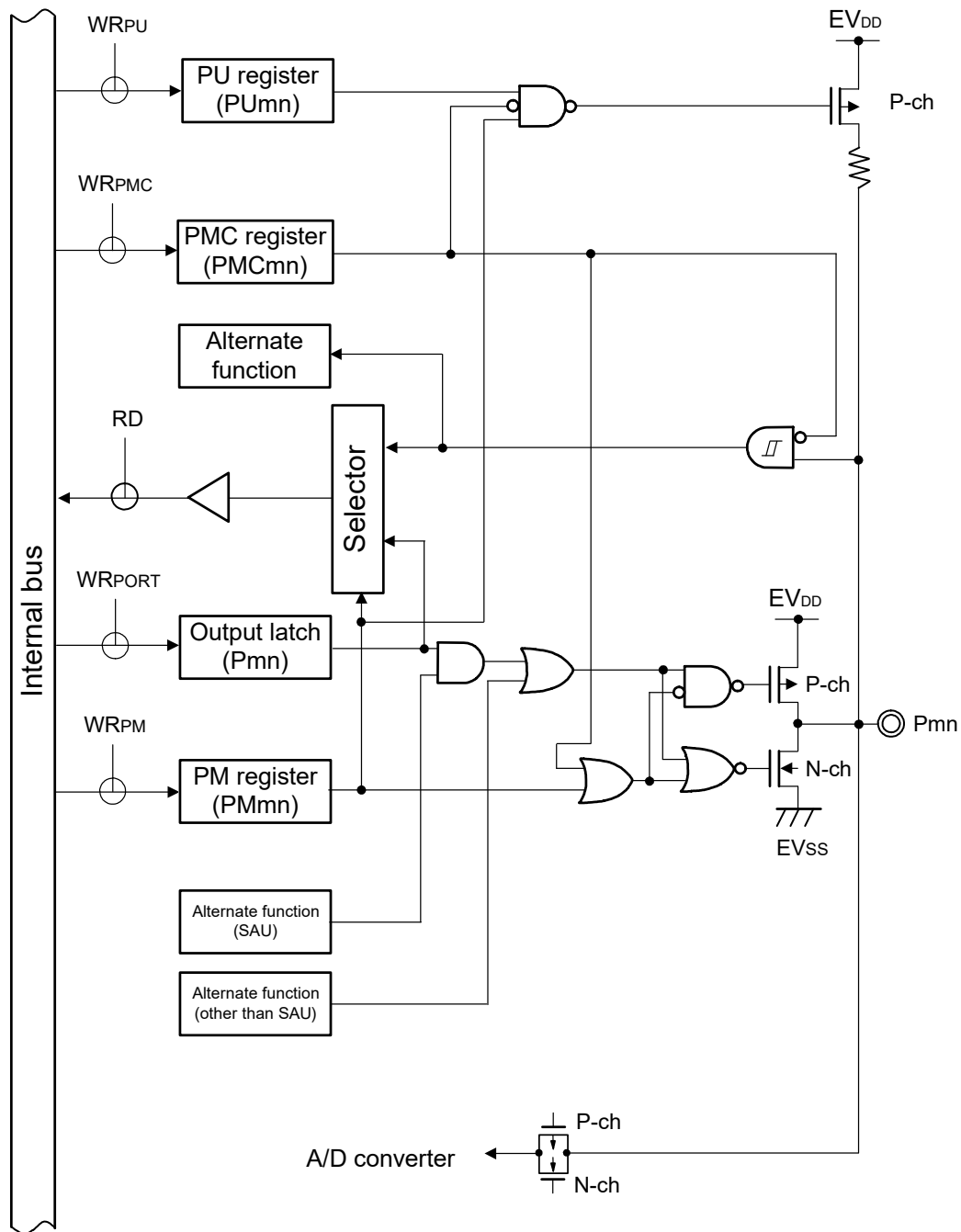

- Remarks**
1. For alternate functions, see 2.1 Port Function.
 2. SAU: Serial array unit

Figure 2-9. Pin Block Diagram for Pin Type 7-3-2

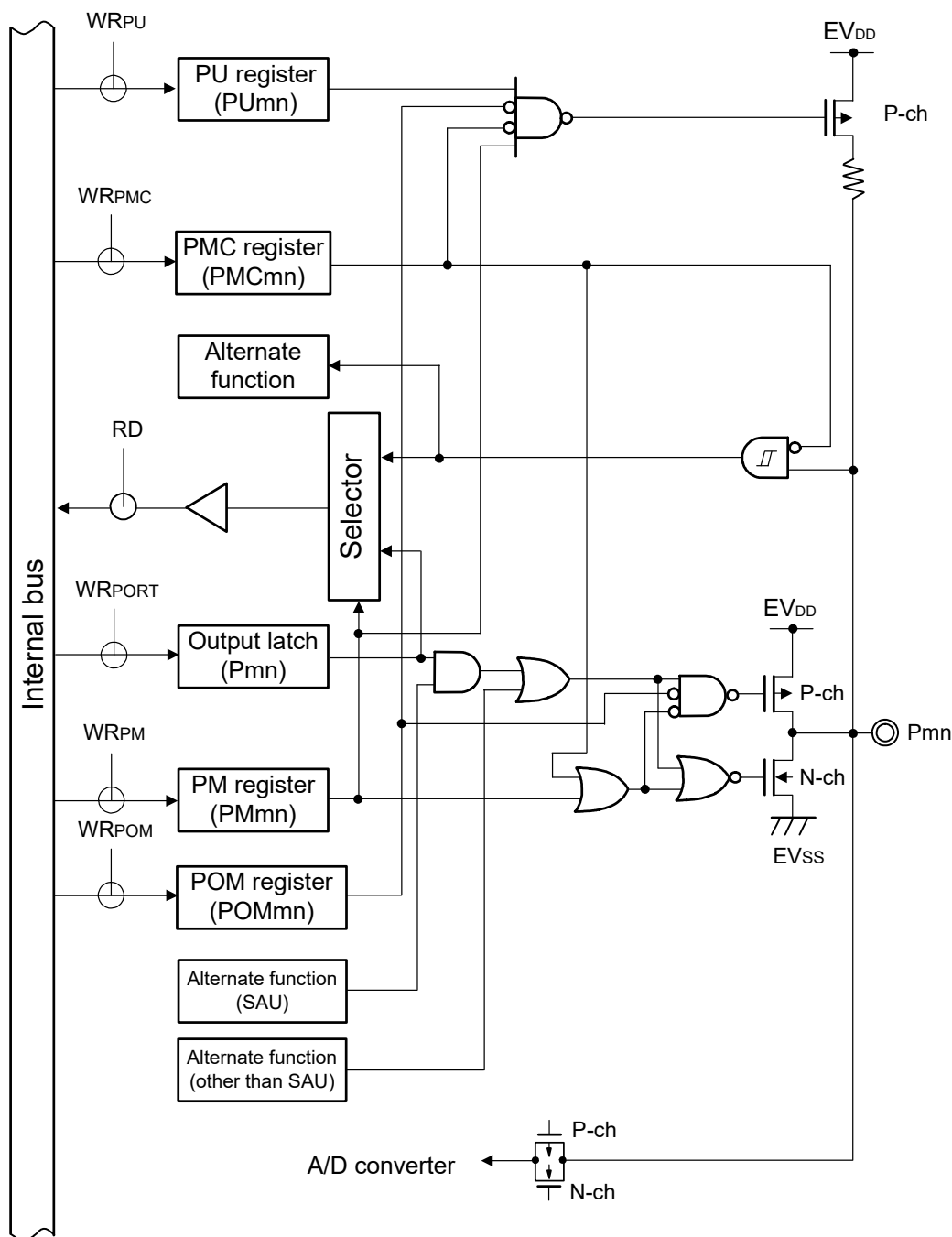

Caution The input buffer is enabled even if the type 7-3-2 pin is operating as an output when the N-ch open drain output mode is selected by the corresponding bit in the port output mode register (POMxx). This may lead to a through current flowing through the type 7-3-2 pin when the voltage level on this pin is intermediate. Changing the output level when the N-ch open drain output mode is selected may cause a glitch (EV_{DD} level).

- Remarks**
1. For alternate functions, see 2.1 Port Function.
 2. SAU: Serial array unit

Figure 2-10. Pin Block Diagram for Pin Type 8-1-1

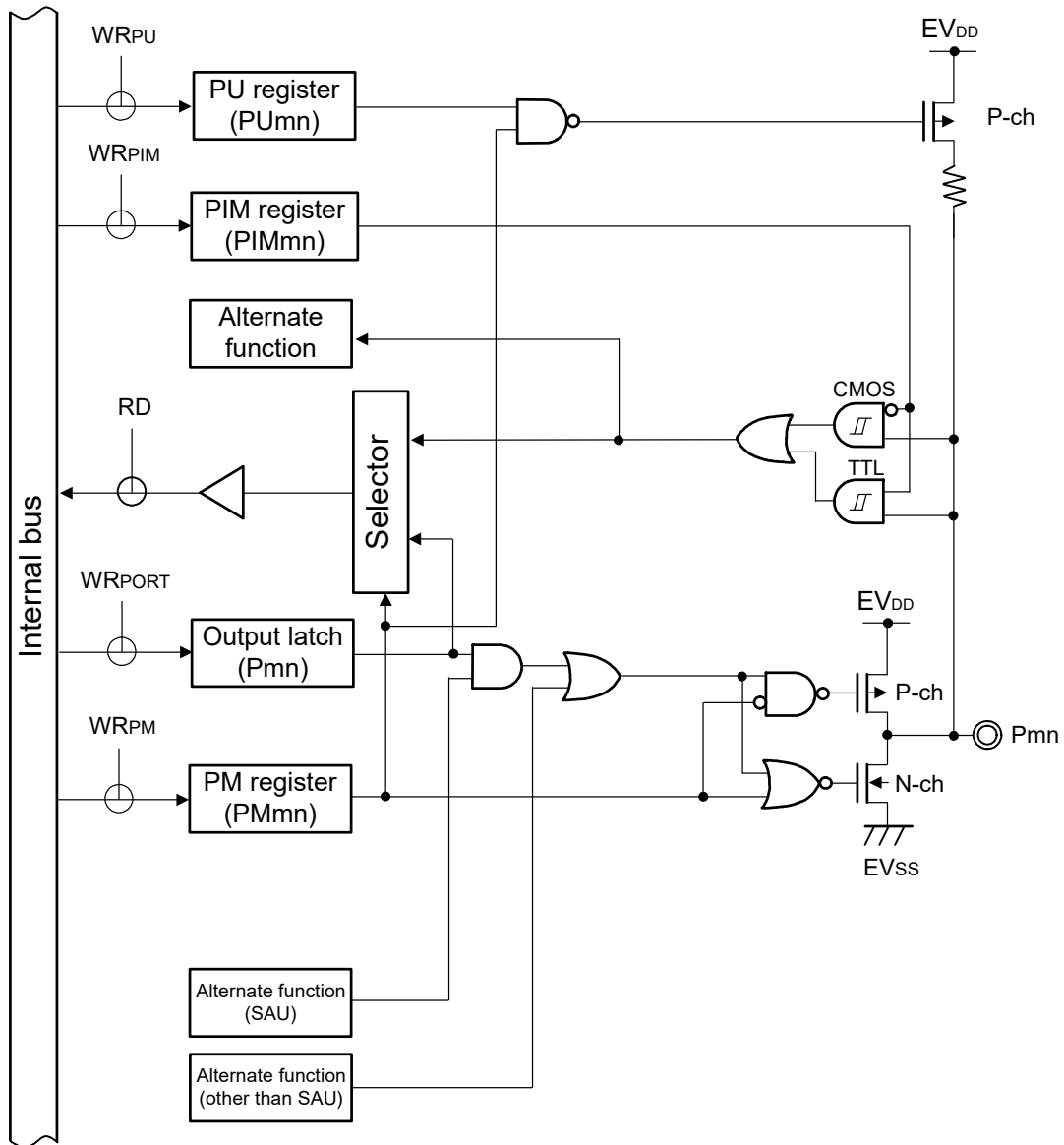

Caution When the type 8-1-1 pin is set to TTL input buffer by the corresponding bit in the port input mode register (PIMxx) and is driven high, a through current may flow through the type 8-1-1 pin due to the configuration of the TTL input buffer. Drive the type 8-1-1 pin low to prevent the through current.

- Remarks**
1. For alternate functions, see 2.1 Port Function.
 2. SAU: Serial array unit

Figure 2-11. Pin Block Diagram for Pin Type 8-1-2

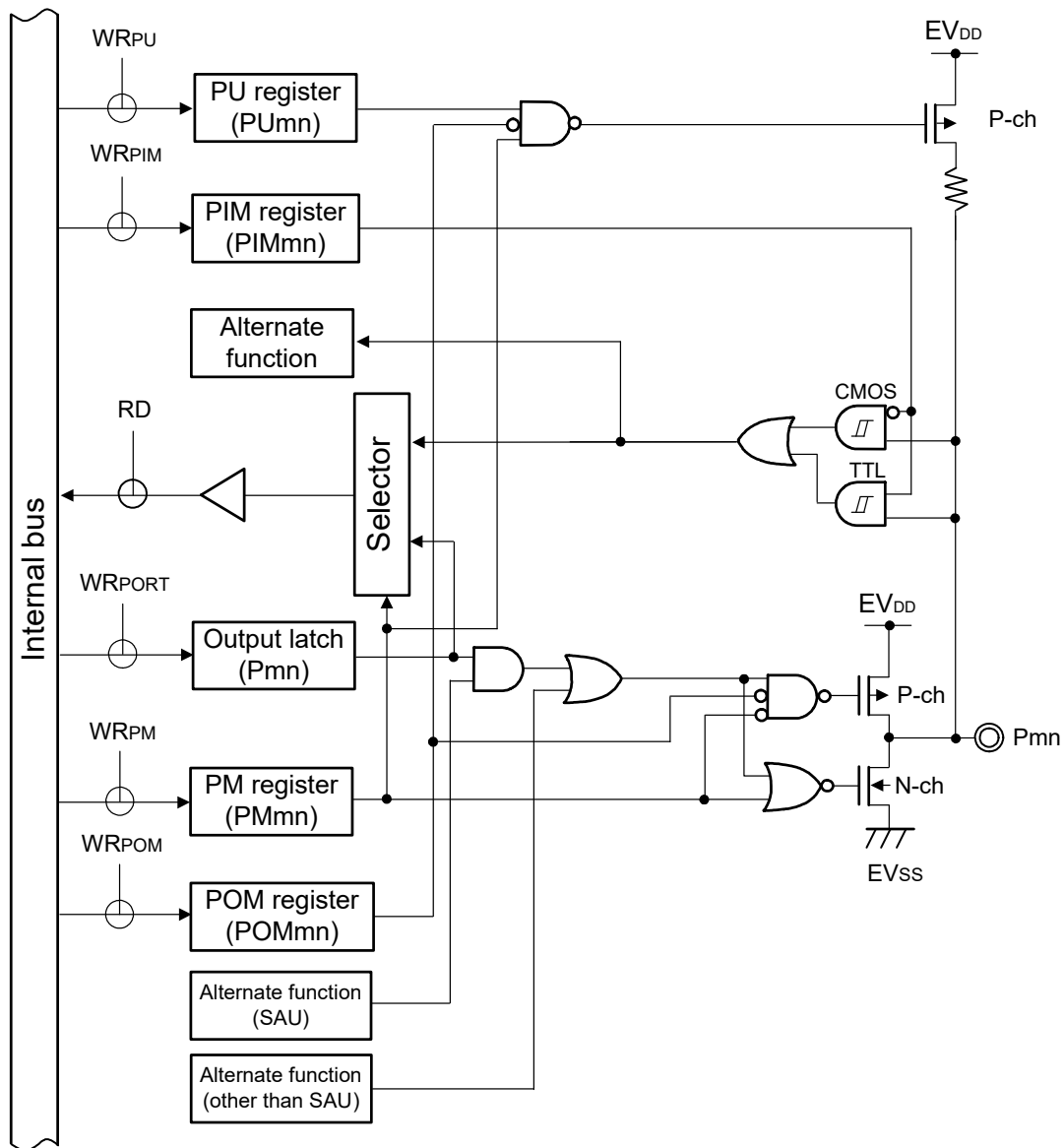

- Cautions 1.** The input buffer is enabled even if the type 8-1-2 pin is operating as an output when the N-ch open drain output mode is selected by the corresponding bit in the port output mode register (POMxx). This may lead to a through current flowing through the type 8-1-2 pin when the voltage level on this pin is intermediate. Changing the output level when the N-ch open drain output mode is selected may cause a glitch (EV_{DD} level).
- 2.** When the type 8-1-2 pin is set to TTL input buffer by the corresponding bit in the port input mode register (PIMxx) and is driven high, a through current may flow through the type 8-1-2 pin due to the configuration of the TTL input buffer. Drive the type 8-1-2 pin low to prevent the through current.

- Remarks 1.** For alternate functions, see 2.1 Port Function.
- 2.** SAU: Serial array unit

Figure 2-12. Pin Block Diagram for Pin Type 8-3-1

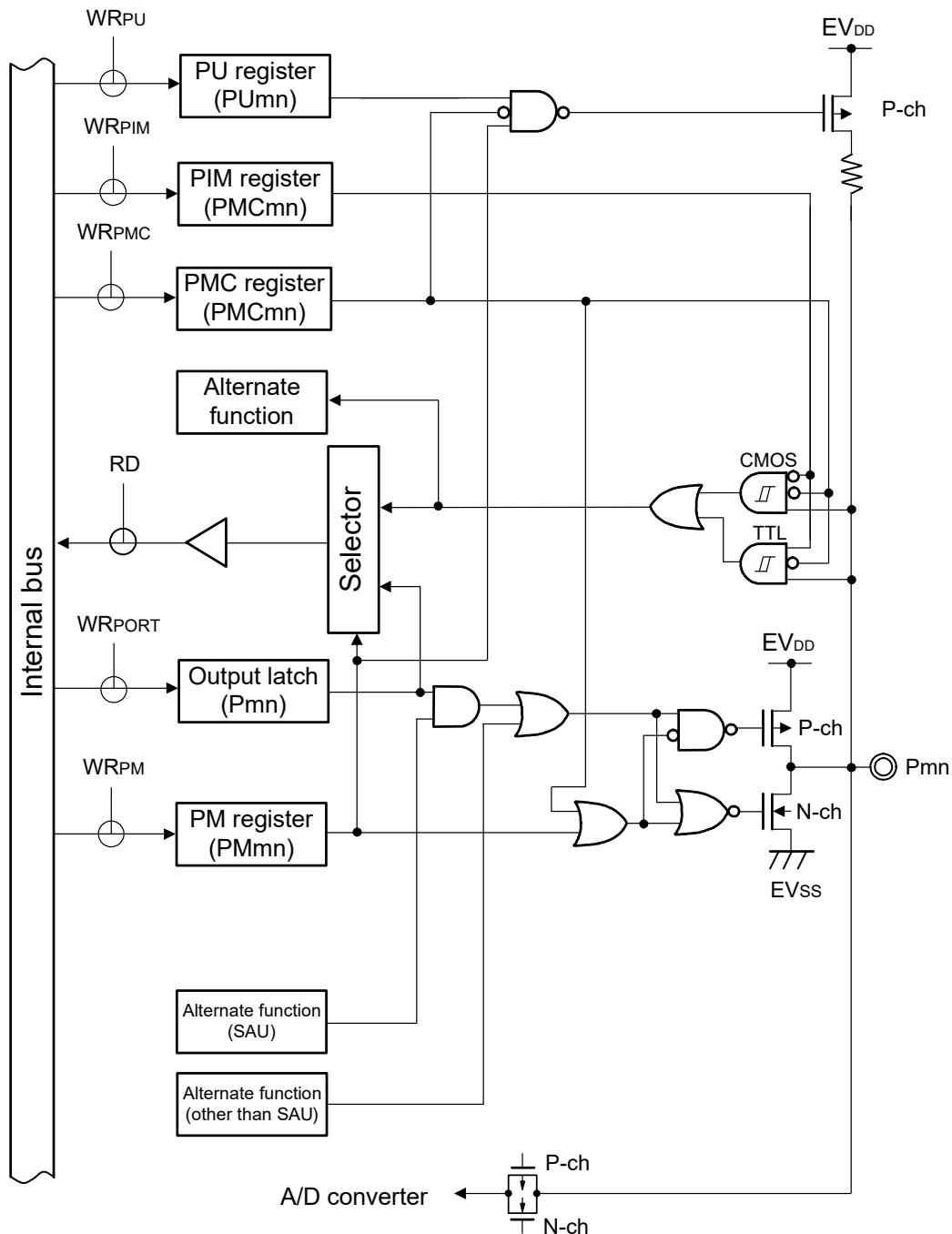

Caution When the type 8-3-1 pin is set to TTL input buffer by the corresponding bit in the port input mode register (PIMxx) and is driven high, a through current may flow through the type 8-3-1 pin due to the configuration of the TTL input buffer. Drive the type 8-3-1 pin low to prevent the through current.

- Remarks**
1. For alternate functions, see 2.1 Port Function.
 2. SAU: Serial array unit

Figure 2-13. Pin Block Diagram for Pin Type 8-3-2

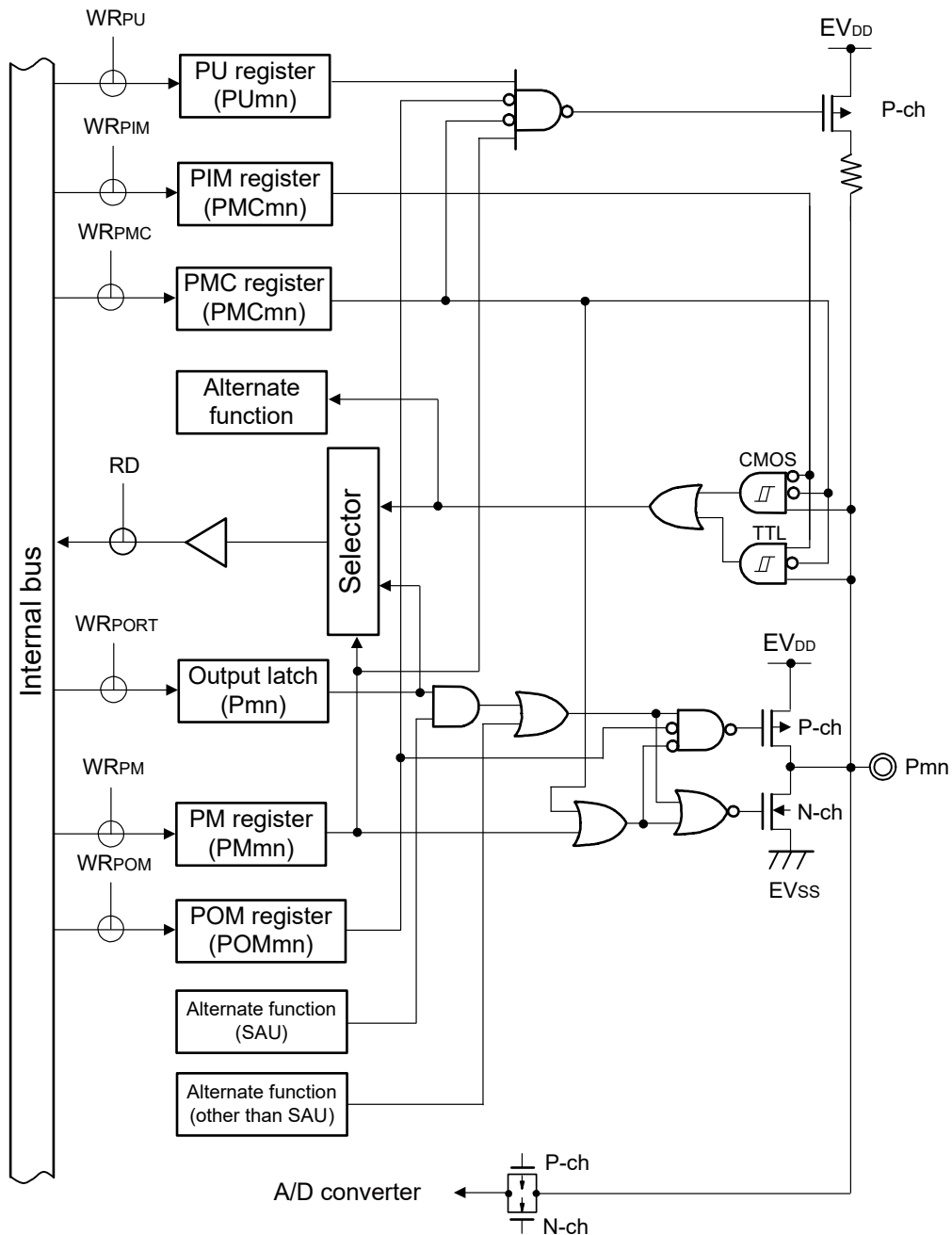

- Cautions 1.** The input buffer is enabled even if the type 8-3-2 pin is operating as an output when the N-ch open drain output mode is selected by the corresponding bit in the port output mode register (POMxx). This may lead to a through current flowing through the type 8-3-2 pin when the voltage level on this pin is intermediate. Changing the output level when the N-ch open drain output mode is selected may cause a glitch (EV_{DD} level).
- 2.** When the type 8-3-2 pin is set to TTL input buffer by the corresponding bit in the port input mode register (PIMxx) and is driven high, a through current may flow through the type 8-3-2 pin due to the configuration of the TTL input buffer. Drive the type 8-3-2 pin low to prevent the through current.

- Remarks 1.** For alternate functions, see 2.1 Port Function.
- 2.** SAU: Serial array unit

Figure 2-14. Pin Block Diagram for Pin Type 12-1-1

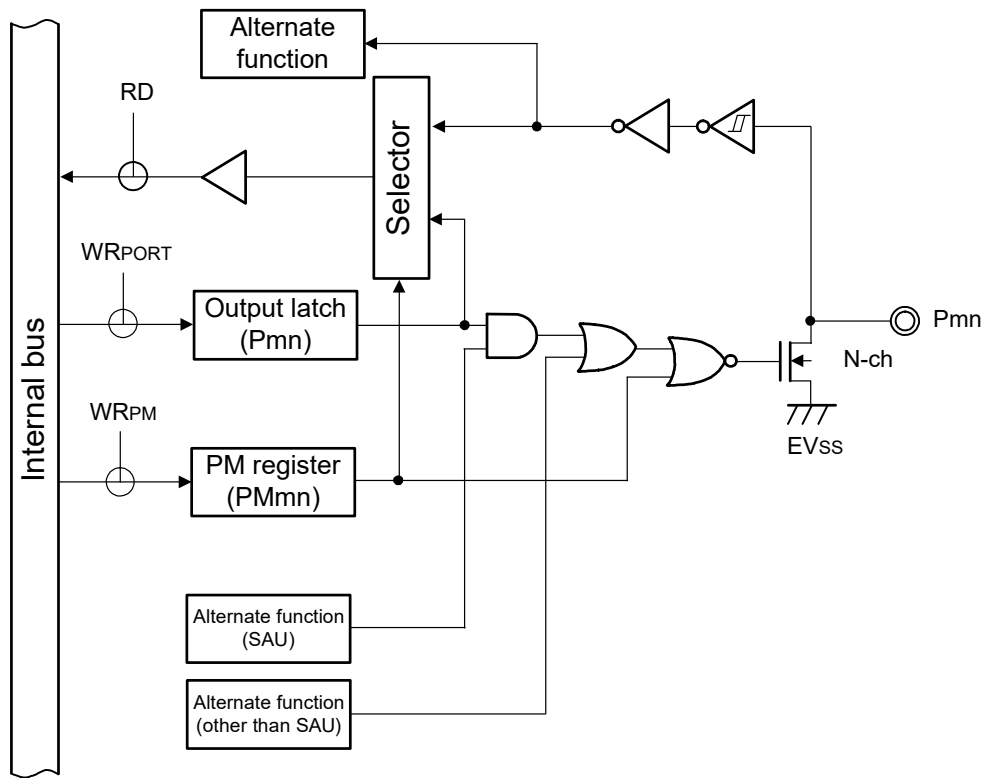

Caution The input buffer is enabled even if the type 12-1-1 pin is operating as an output. This may lead to a through current flowing through the type 12-1-1 pin when the voltage level on this pin is intermediate.

- Remarks**
1. For alternate functions, see 2.1 Port Function.
 2. SAU: Serial array unit

CHAPTER 3 CPU ARCHITECTURE

3.1 Memory Space

Products in the RL78/G13 can access a 1-MB address space. Figures 3-1 to 3-10 show the memory maps.

Figure 3-1. Memory Map (R5F100xA, R5F101xA (x = 6 to 8, A to C, E to G))

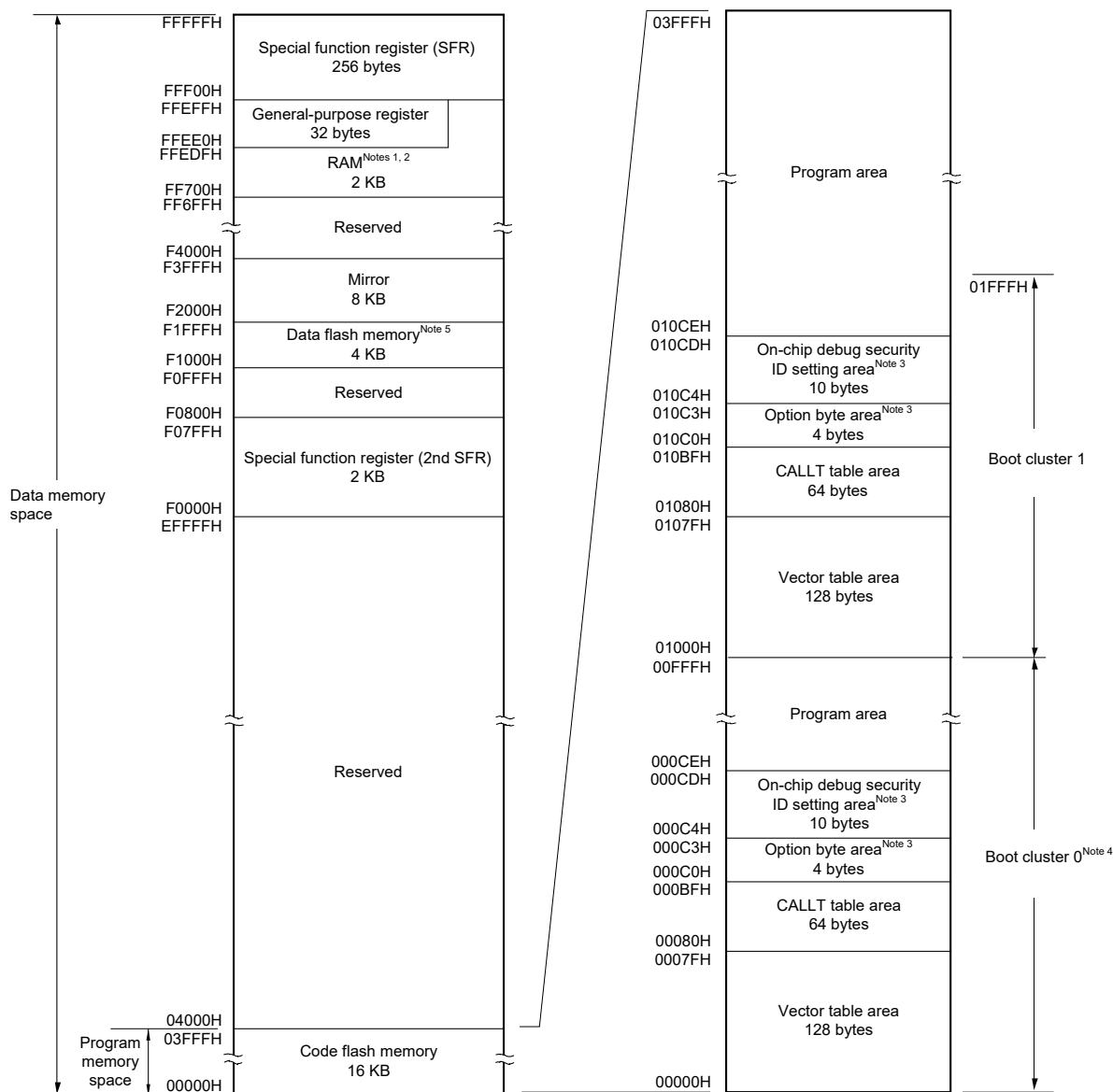

- Notes**
- Do not allocate the stack area, data buffers for use by the flash library, arguments of library functions, branch destinations in the processing of vectored interrupts, or destinations or sources for DMA transfer to the area from FFE20H to FFEDFH when performing self-programming or rewriting of the data flash memory.
 - Instructions can be executed from the RAM area excluding the general-purpose register area.
 - When boot swap is not used: Set the option bytes to 000C0H to 000C3H, and the on-chip debug security IDs to 000C4H to 000CDH.
When boot swap is used: Set the option bytes to 000C0H to 000C3H and 010C0H to 010C3H, and the on-chip debug security IDs to 000C4H to 000CDH and 010C4H to 010CDH.
 - Writing boot cluster 0 can be prohibited depending on the setting of security (see **25.7 Security Settings**).
 - The areas are reserved in the R5F101xA.

Caution While RAM parity error resets are enabled (RPERDIS = 0), be sure to initialize RAM areas where data access is to proceed and the RAM area + 10 bytes when instructions are fetched from RAM areas, respectively.

Reset signal generation sets RAM parity error resets to enabled (RPERDIS = 0). For details, see **22.3.3 RAM parity error detection function**.

Figure 3-2. Memory Map (R5F100xC, R5F101xC (x = 6 to 8, A to C, E to G, J, L))

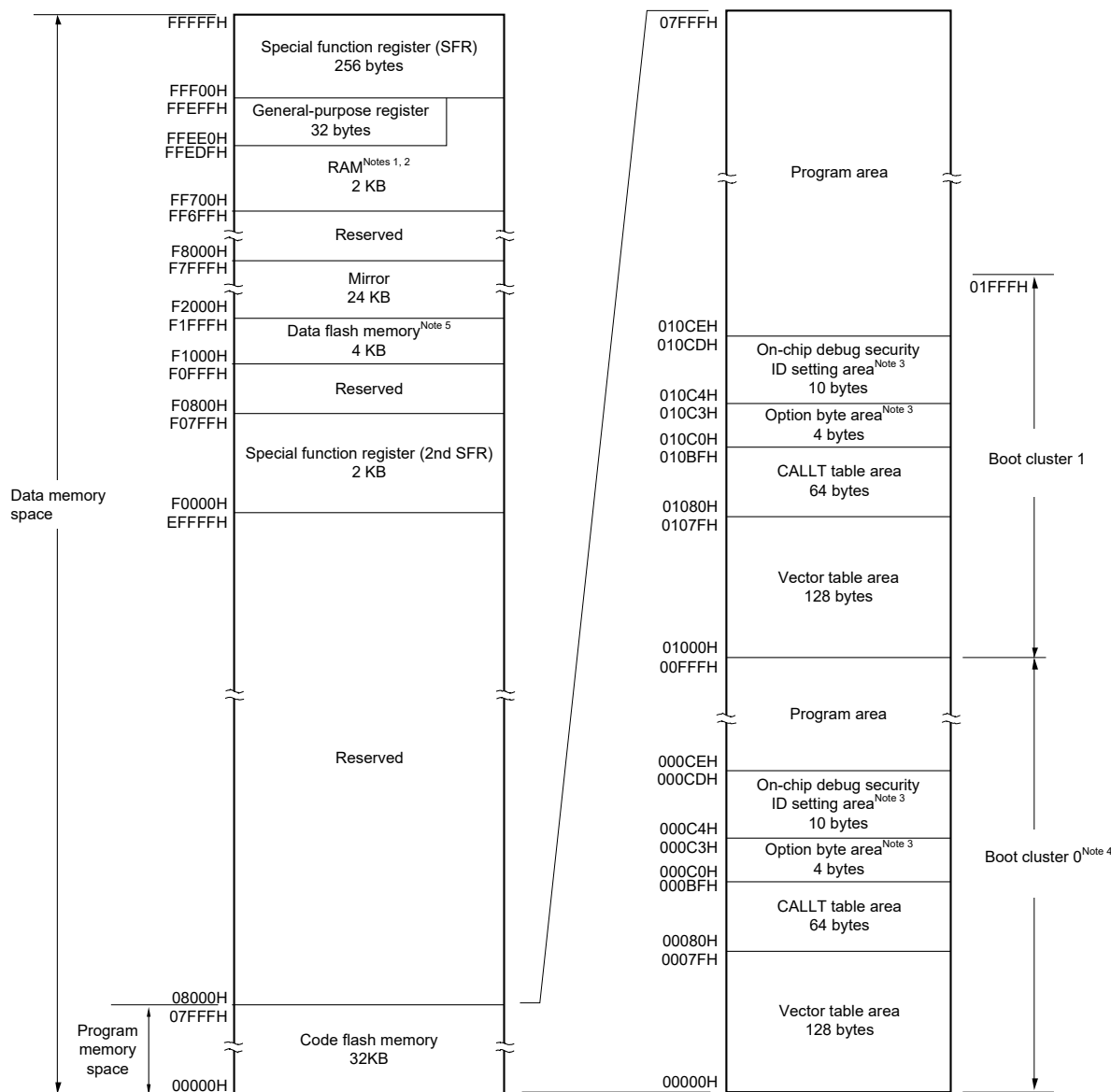

- Notes**
- Do not allocate the stack area, data buffers for use by the flash library, arguments of library functions, branch destinations in the processing of vectored interrupts, or destinations or sources for DMA transfer to the area from FFE20H to FFEDFH when performing self-programming or rewriting of the data flash memory.
 - Instructions can be executed from the RAM area excluding the general-purpose register area.
 - When boot swap is not used: Set the option bytes to 000C0H to 000C3H, and the on-chip debug security IDs to 000C4H to 000CDH.
When boot swap is used: Set the option bytes to 000C0H to 000C3H and 010C0H to 010C3H, and the on-chip debug security IDs to 000C4H to 000CDH and 010C4H to 010CDH.
 - Writing boot cluster 0 can be prohibited depending on the setting of security (see 25.7 Security Settings).
 - The areas are reserved in the R5F101xC.

Caution While RAM parity error resets are enabled (RPERDIS = 0), be sure to initialize RAM areas where data access is to proceed and the RAM area + 10 bytes when instructions are fetched from RAM areas, respectively.

Reset signal generation sets RAM parity error resets to enabled (RPERDIS = 0). For details, see 22.3.3 RAM parity error detection function.

Figure 3-3. Memory Map (R5F100xD, R5F101xD (x = 6 to 8, A to C, E to G, J, L))

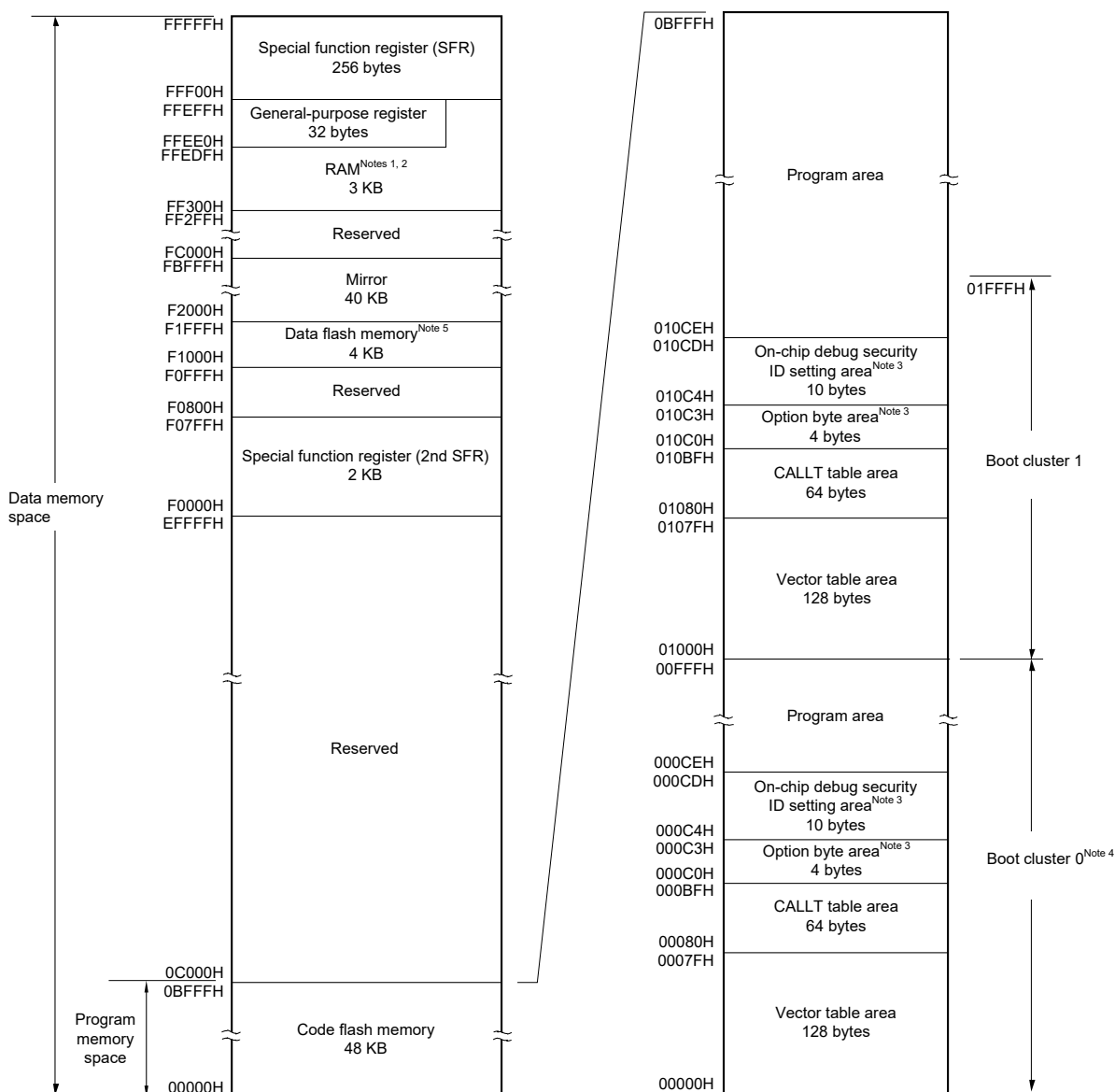

- Notes**
- Do not allocate the stack area, data buffers for use by the flash library, arguments of library functions, branch destinations in the processing of vectored interrupts, or destinations or sources for DMA transfer to the area from FFE20H to FFEDFH when performing self-programming or rewriting of the data flash memory. The RAM area used by the flash library starts at FF300H. For the RAM areas used by the flash library, see **Self RAM list of Flash Self-Programming Library for RL78 Family (R20UT2944)**.
 - Instructions can be executed from the RAM area excluding the general-purpose register area.
 - When boot swap is not used: Set the option bytes to 000C0H to 000C3H, and the on-chip debug security IDs to 000C4H to 000CDH.
When boot swap is used: Set the option bytes to 000C0H to 000C3H and 010C0H to 010C3H, and the on-chip debug security IDs to 000C4H to 000CDH and 010C4H to 010CDH.
 - Writing boot cluster 0 can be prohibited depending on the setting of security (see **25.7 Security Settings**).
 - The areas are reserved in the R5F101xD.

Caution While RAM parity error resets are enabled (RPERDIS = 0), be sure to initialize RAM areas where data access is to proceed and the RAM area + 10 bytes when instructions are fetched from RAM areas, respectively.
Reset signal generation sets RAM parity error resets to enabled (RPERDIS = 0). For details, see **22.3.3 RAM parity error detection function**.

Figure 3-4. Memory Map (R5F100xE, R5F101xE (x = 6 to 8, A to C, E to G, J, L))

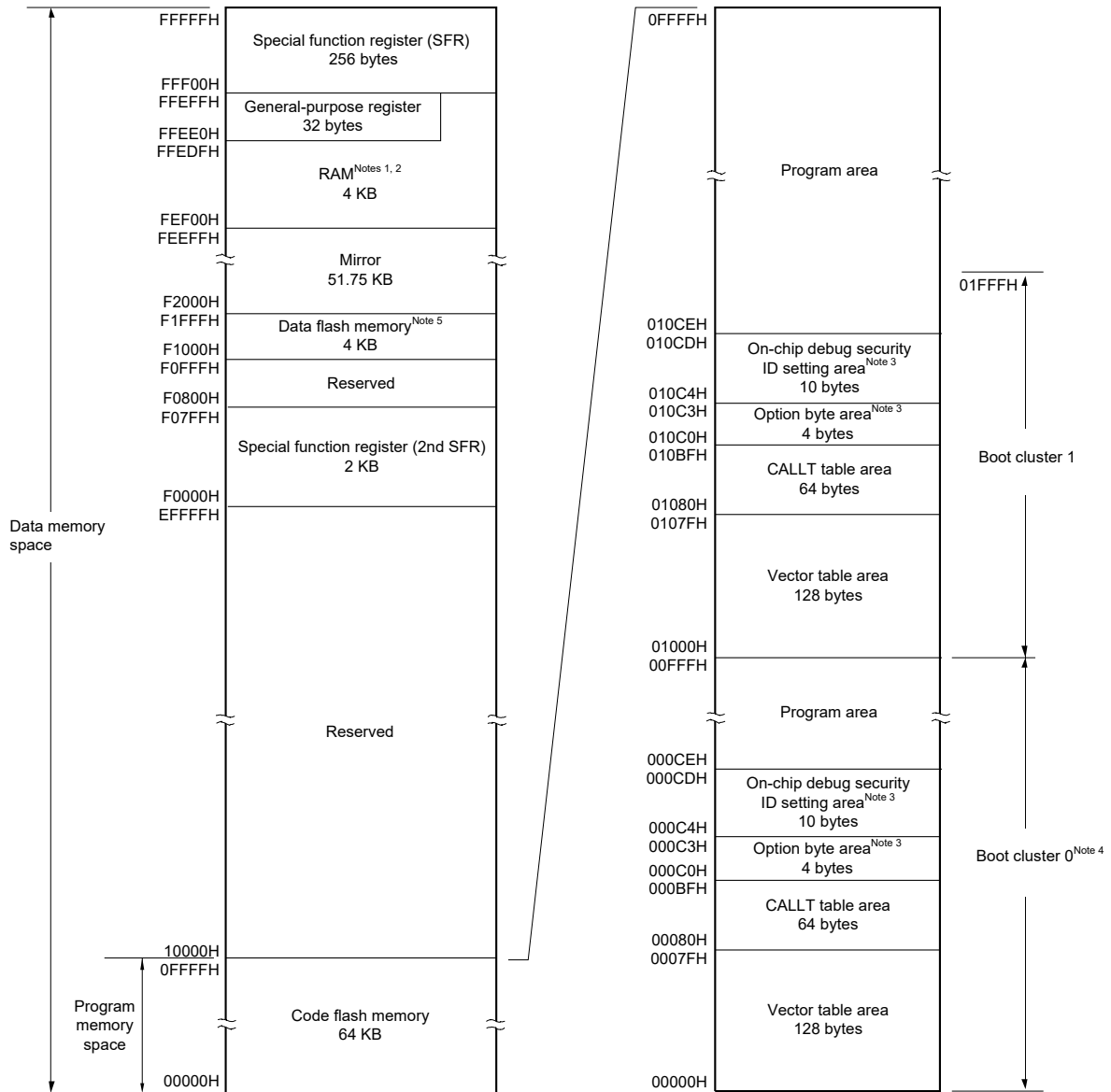

- Notes**
- Do not allocate the stack area, data buffers for use by the flash library, arguments of library functions, branch destinations in the processing of vectored interrupts, or destinations or sources for DMA transfer to the area from FFE20H to FFEDFH when performing self-programming or rewriting of the data flash memory. The RAM area used by the flash library starts at FEF00H. For the RAM areas used by the flash library, see **Self RAM list of Flash Self-Programming Library for RL78 Family (R20UT2944)**.
 - Instructions can be executed from the RAM area excluding the general-purpose register area.
 - When boot swap is not used: Set the option bytes to 000C0H to 000C3H, and the on-chip debug security IDs to 000C4H to 000CDH.
When boot swap is used: Set the option bytes to 000C0H to 000C3H and 010C0H to 010C3H, and the on-chip debug security IDs to 000C4H to 000CDH and 010C4H to 010CDH.
 - Writing boot cluster 0 can be prohibited depending on the setting of security (see **25.7 Security Settings**).
 - The areas are reserved in the R5F101xE.

Caution While RAM parity error resets are enabled (RPERDIS = 0), be sure to initialize RAM areas where data access is to proceed and the RAM area + 10 bytes when instructions are fetched from RAM areas, respectively.
Reset signal generation sets RAM parity error resets to enabled (RPERDIS = 0). For details, see **22.3.3 RAM parity error detection function**.

Figure 3-5. Memory Map (R5F100xF, R5F101xF (x = A to C, E to G, J, L, M, P))

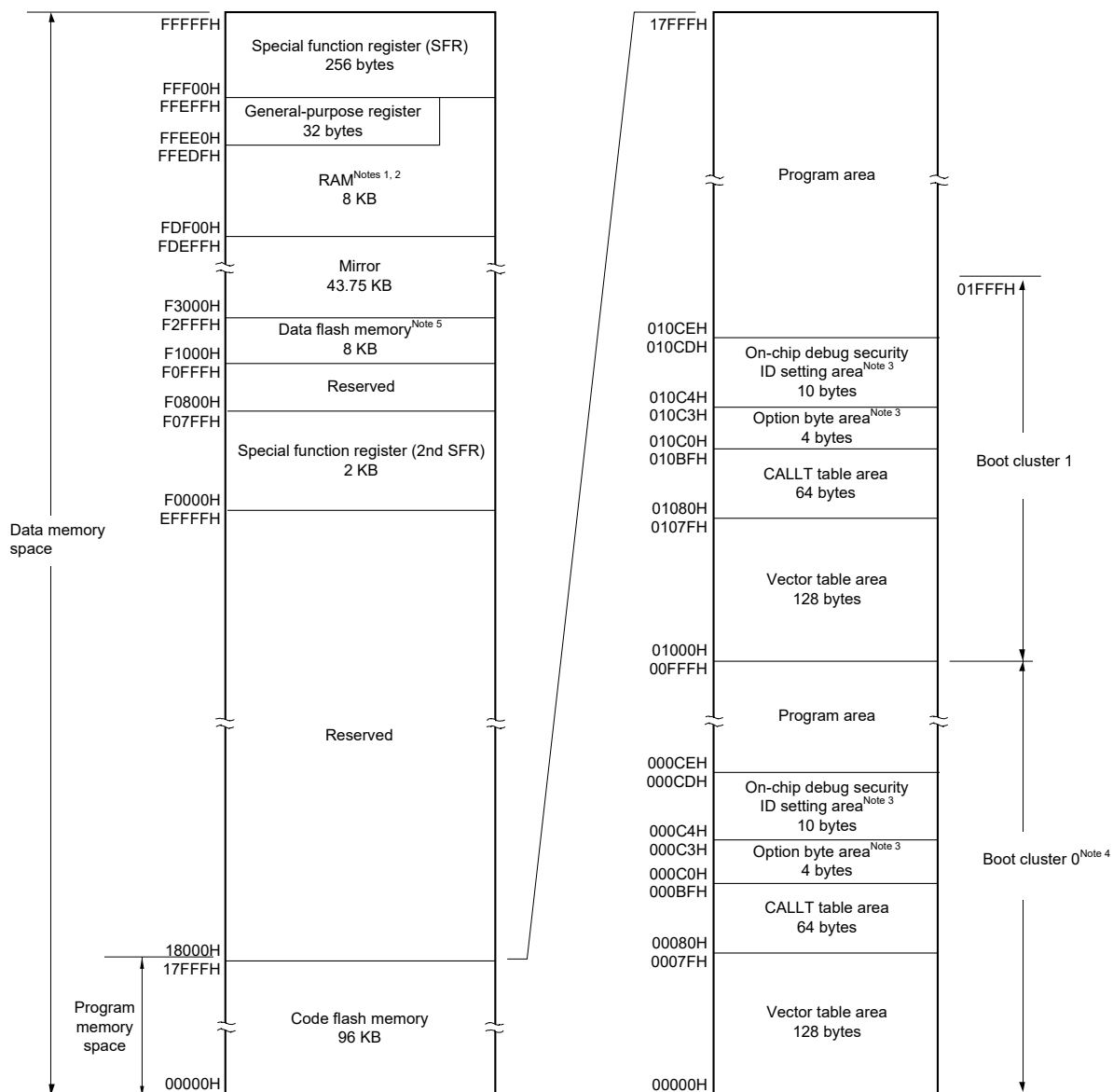

- Notes**
- Do not allocate the stack area, data buffers for use by the flash library, arguments of library functions, branch destinations in the processing of vectored interrupts, or destinations or sources for DMA transfer to the area from FFE20H to FFEDFH when performing self-programming or rewriting of the data flash memory.
 - Instructions can be executed from the RAM area excluding the general-purpose register area.
 - When boot swap is not used: Set the option bytes to 000C0H to 000C3H, and the on-chip debug security IDs to 000C4H to 000CDH.
When boot swap is used: Set the option bytes to 000C0H to 000C3H and 010C0H to 010C3H, and the on-chip debug security IDs to 000C4H to 000CDH and 010C4H to 010CDH.
 - Writing boot cluster 0 can be prohibited depending on the setting of security (see 25.7 Security Settings).
 - The areas are reserved in the R5F101xF.

Caution While RAM parity error resets are enabled (RPERDIS = 0), be sure to initialize RAM areas where data access is to proceed and the RAM area + 10 bytes when instructions are fetched from RAM areas, respectively.

Reset signal generation sets RAM parity error resets to enabled (RPERDIS = 0). For details, see 22.3.3 RAM parity error detection function.

Figure 3-6. Memory Map (R5F100xG, R5F101xG (x = A to C, E to G, J, L, M, P))

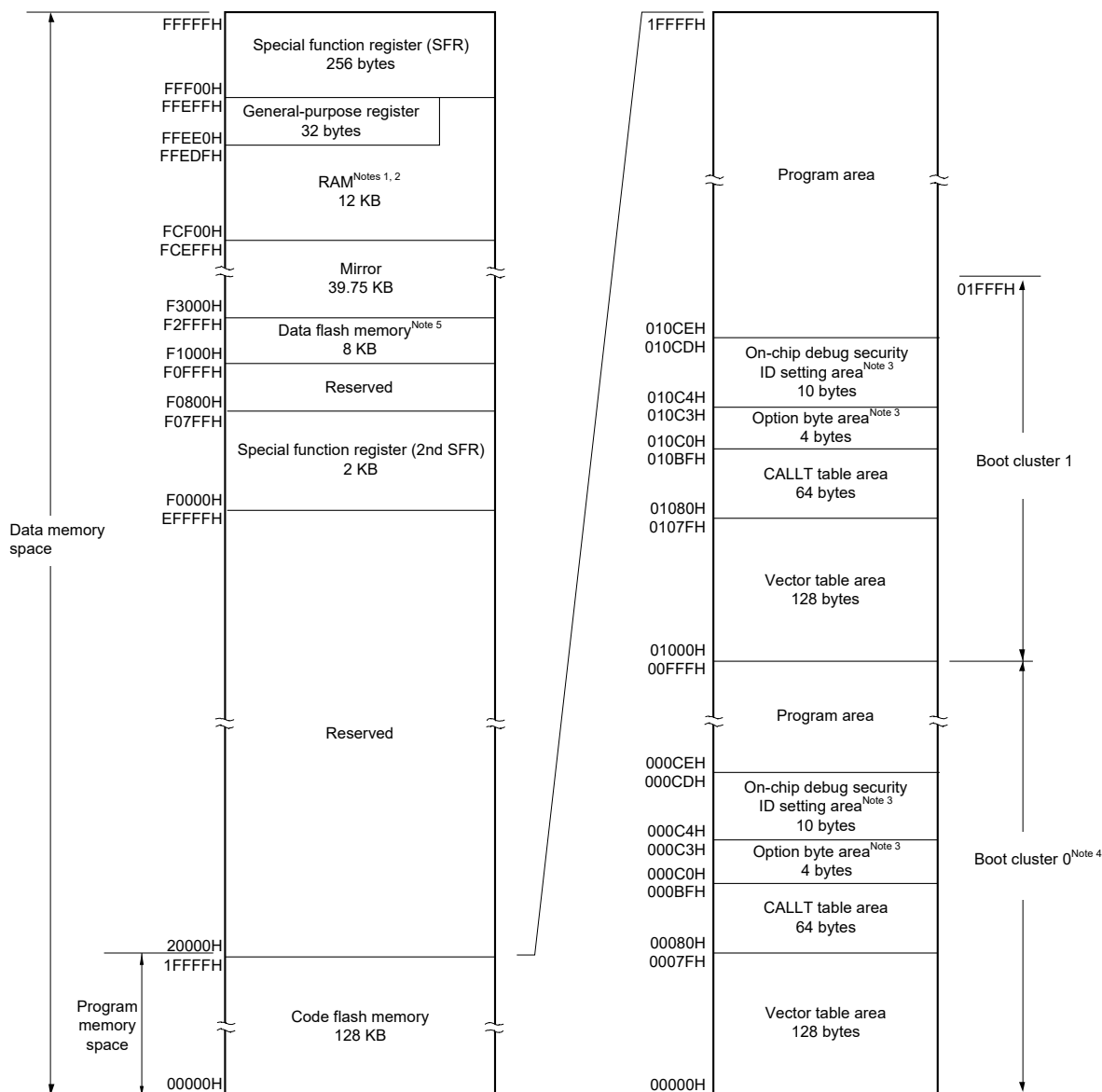

- Notes**
- Do not allocate the stack area, data buffers for use by the flash library, arguments of library functions, branch destinations in the processing of vectored interrupts, or destinations or sources for DMA transfer to the area from FFE20H to FFEDFH when performing self-programming or rewriting of the data flash memory.
 - Instructions can be executed from the RAM area excluding the general-purpose register area.
 - When boot swap is not used: Set the option bytes to 000C0H to 000C3H, and the on-chip debug security IDs to 000C4H to 000CDH.
When boot swap is used: Set the option bytes to 000C0H to 000C3H and 010C0H to 010C3H, and the on-chip debug security IDs to 000C4H to 000CDH and 010C4H to 010CDH.
 - Writing boot cluster 0 can be prohibited depending on the setting of security (see 25.7 Security Settings).
 - The areas are reserved in the R5F101xG.

Caution While RAM parity error resets are enabled (RPERDIS = 0), be sure to initialize RAM areas where data access is to proceed and the RAM area + 10 bytes when instructions are fetched from RAM areas, respectively.

Reset signal generation sets RAM parity error resets to enabled (RPERDIS = 0). For details, see 22.3.3 RAM parity error detection function.

Figure 3-7. Memory Map (R5F100xH, R5F101xH (x = E to G, J, L, M, P, S))

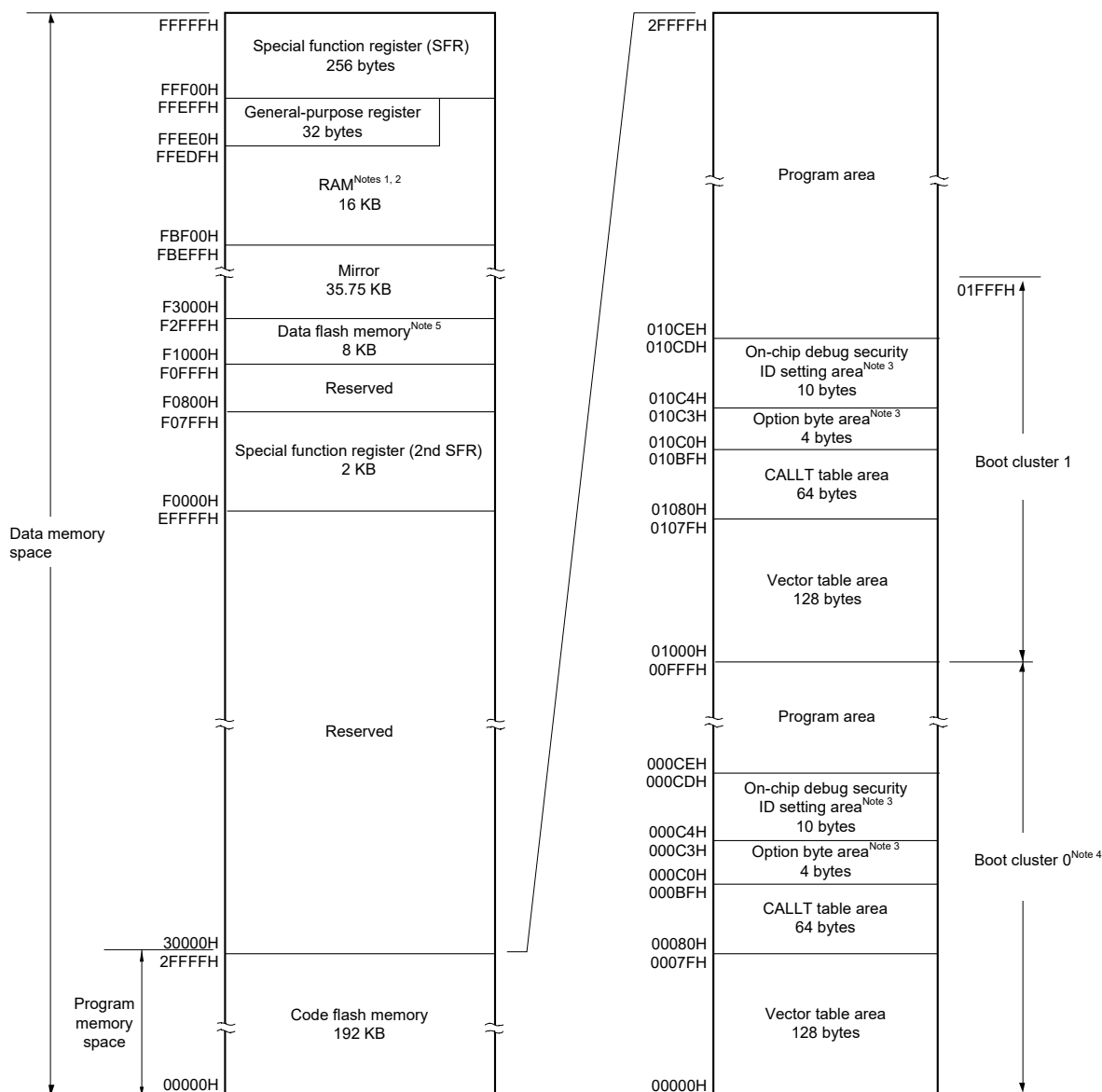

- Notes**
- Do not allocate the stack area, data buffers for use by the flash library, arguments of library functions, branch destinations in the processing of vectored interrupts, or destinations or sources for DMA transfer to the area from FFE20H to FFEDFH when performing self-programming or rewriting of the data flash memory.
 - Instructions can be executed from the RAM area excluding the general-purpose register area.
 - When boot swap is not used: Set the option bytes to 000C0H to 000C3H, and the on-chip debug security IDs to 000C4H to 000CDH.
When boot swap is used: Set the option bytes to 000C0H to 000C3H and 010C0H to 010C3H, and the on-chip debug security IDs to 000C4H to 000CDH and 010C4H to 010CDH.
 - Writing boot cluster 0 can be prohibited depending on the setting of security (see **25.7 Security Settings**).
 - The areas are reserved in the R5F101xH.

Caution While RAM parity error resets are enabled (RPERDIS = 0), be sure to initialize RAM areas where data access is to proceed and the RAM area + 10 bytes when instructions are fetched from RAM areas, respectively.

Reset signal generation sets RAM parity error resets to enabled (RPERDIS = 0). For details, see **22.3.3 RAM parity error detection function**.

Figure 3-8. Memory Map (R5F100xJ, R5F101xJ (x = F, G, J, L, M, P, S))

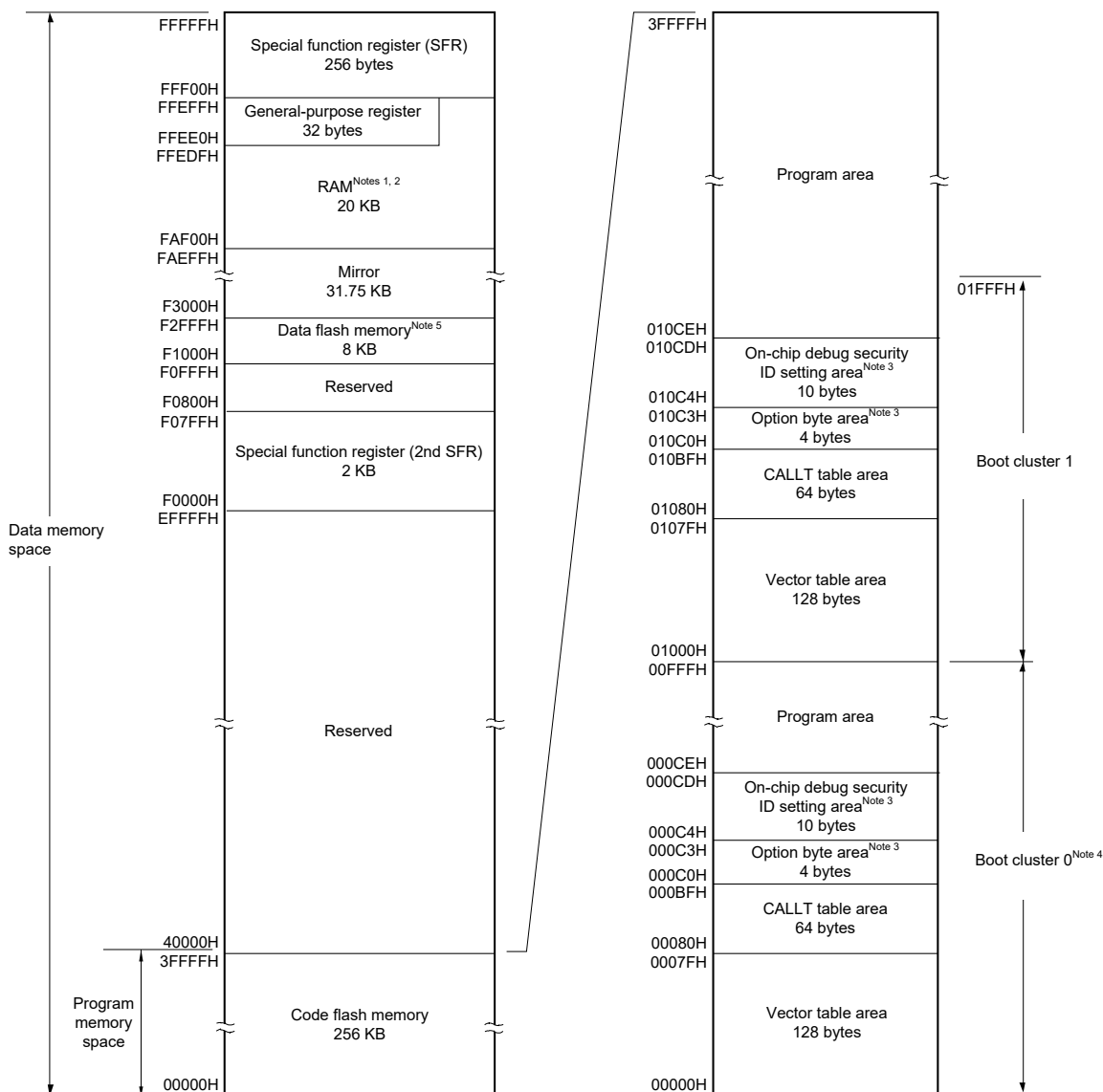

- Notes**
- Do not allocate the stack area, data buffers for use by the flash library, arguments of library functions, branch destinations in the processing of vectored interrupts, or destinations or sources for DMA transfer to the area from FFE20H to FFEDFH when performing self-programming or rewriting of the data flash memory. For R5F100xJ and R5F101xJ (x = F, G, J, L, M, P), the RAM area used by the flash library starts at FAF00H. For the RAM areas used by the flash library, see **Self RAM list of Flash Self-Programming Library for RL78 Family (R20UT2944)**.
 - Instructions can be executed from the RAM area excluding the general-purpose register area.
 - When boot swap is not used: Set the option bytes to 000C0H to 000C3H, and the on-chip debug security IDs to 000C4H to 000CDH.
When boot swap is used: Set the option bytes to 000C0H to 000C3H and 010C0H to 010C3H, and the on-chip debug security IDs to 000C4H to 000CDH and 010C4H to 010CDH.
 - Writing boot cluster 0 can be prohibited depending on the setting of security (see **25.7 Security Settings**).
 - The areas are reserved in the R5F101xJ.

Caution While RAM parity error resets are enabled (RPERDIS = 0), be sure to initialize RAM areas where data access is to proceed and the RAM area + 10 bytes when instructions are fetched from RAM areas, respectively.
Reset signal generation sets RAM parity error resets to enabled (RPERDIS = 0). For details, see **22.3.3 RAM parity error detection function**.

Figure 3-9. Memory Map (R5F100xK, R5F101xK (x = F, G, J, L, M, P, S))

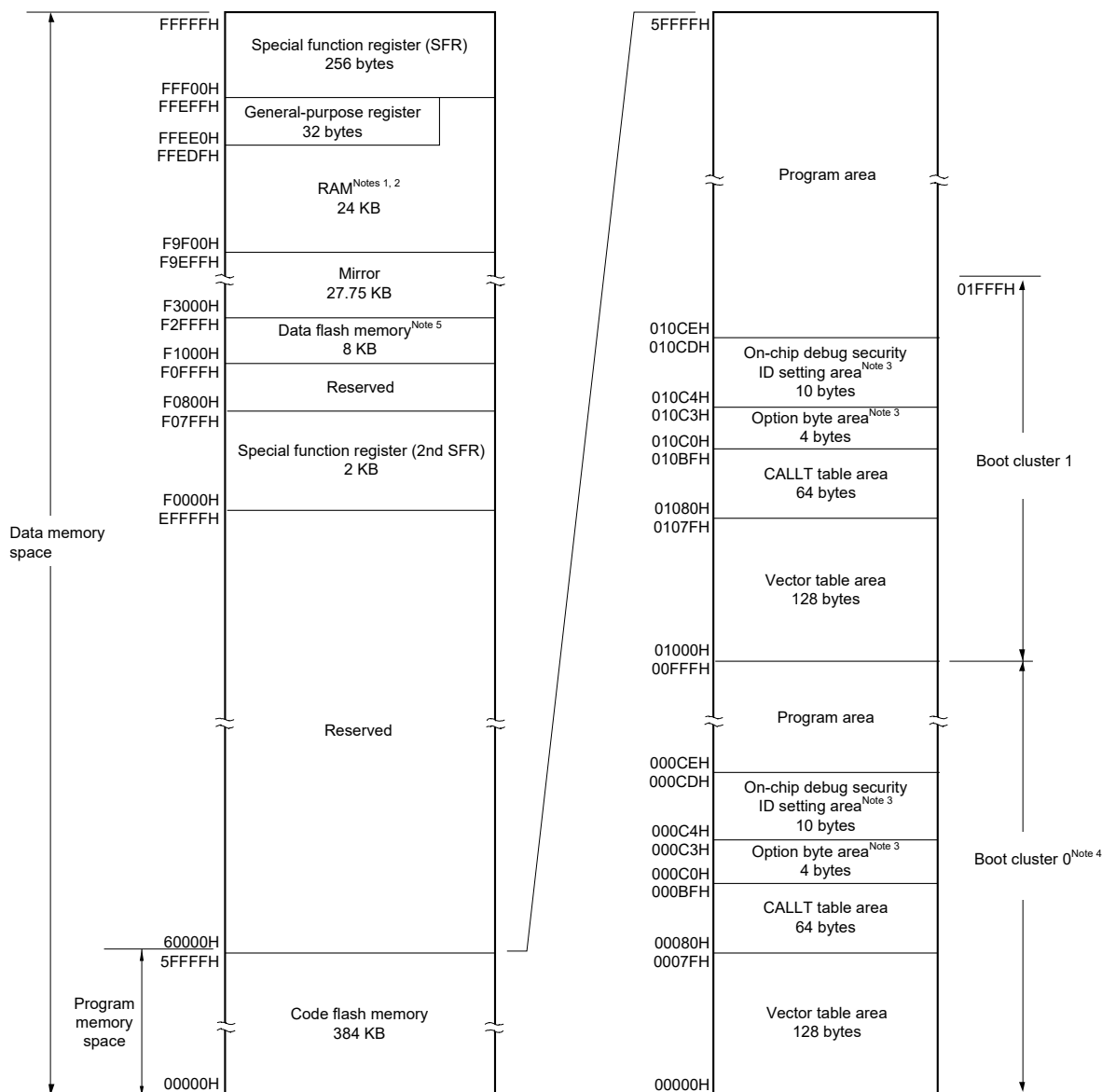

- Notes**
- Do not allocate the stack area, data buffers for use by the flash library, arguments of library functions, branch destinations in the processing of vectored interrupts, or destinations or sources for DMA transfer to the area from FFE20H to FFEDFH when performing self-programming or rewriting of the data flash memory.
 - Instructions can be executed from the RAM area excluding the general-purpose register area.
 - When boot swap is not used: Set the option bytes to 000C0H to 000C3H, and the on-chip debug security IDs to 000C4H to 000CDH.
When boot swap is used: Set the option bytes to 000C0H to 000C3H and 010C0H to 010C3H, and the on-chip debug security IDs to 000C4H to 000CDH and 010C4H to 010CDH.
 - Writing boot cluster 0 can be prohibited depending on the setting of security (see **25.7 Security Settings**).
 - The areas are reserved in the R5F101xK.

Caution While RAM parity error resets are enabled (RPERDIS = 0), be sure to initialize RAM areas where data access is to proceed and the RAM area + 10 bytes when instructions are fetched from RAM areas, respectively.
Reset signal generation sets RAM parity error resets to enabled (RPERDIS = 0). For details, see **22.3.3 RAM parity error detection function**.

Figure 3-10. Memory Map (R5F100xL, R5F101xL (x = F, G, J, L, M, P, S))

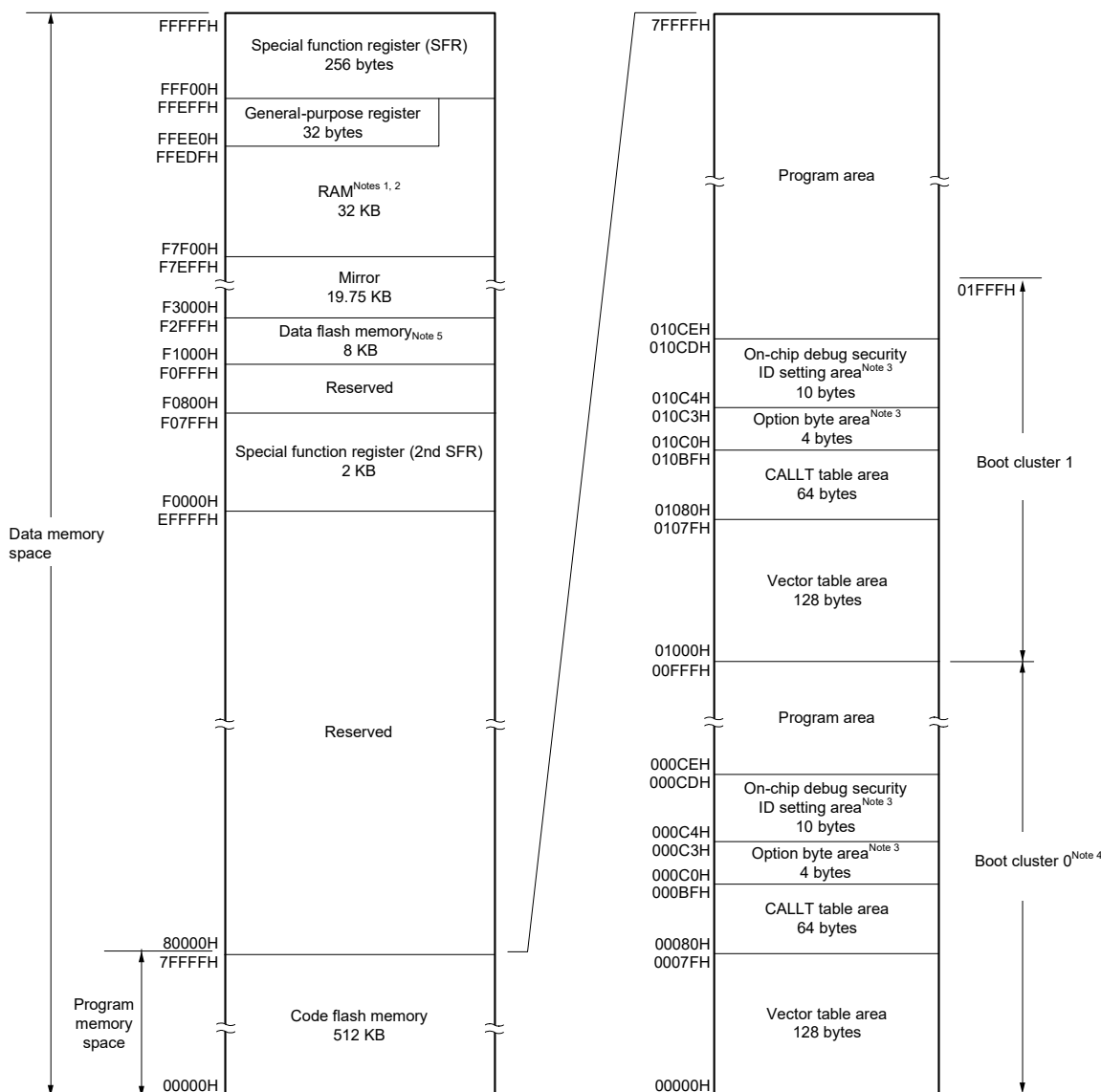

- Notes**
- Do not allocate the stack area, data buffers for use by the flash library, arguments of library functions, branch destinations in the processing of vectored interrupts, or destinations or sources for DMA transfer to the area from FFE20H to FFEDFH when performing self-programming or rewriting of the data flash memory. For The RAM area used by the flash library starts at F7F00H. For the RAM areas used by the flash library, see **Self RAM list of Flash Self-Programming Library for RL78 Family (R20UT2944)**.
 - Instructions can be executed from the RAM area excluding the general-purpose register area.
 - When boot swap is not used: Set the option bytes to 000C0H to 000C3H, and the on-chip debug security IDs to 000C4H to 000CDH.
When boot swap is used: Set the option bytes to 000C0H to 000C3H and 010C0H to 010C3H, and the on-chip debug security IDs to 000C4H to 000CDH and 010C4H to 010CDH.
 - Writing boot cluster 0 can be prohibited depending on the setting of security (see **25.7 Security Settings**).
 - The areas are reserved in the R5F101xL.

Caution While RAM parity error resets are enabled (RPERDIS = 0), be sure to initialize RAM areas where data access is to proceed and the RAM area + 10 bytes when instructions are fetched from RAM areas, respectively.
Reset signal generation sets RAM parity error resets to enabled (RPERDIS = 0). For details, see **22.3.3 RAM parity error detection function**.

Remark The flash memory is divided into blocks (one block = 1 KB). For the address values and block numbers, see **Table 3-1 Correspondence Between Address Values and Block Numbers in Flash Memory.**

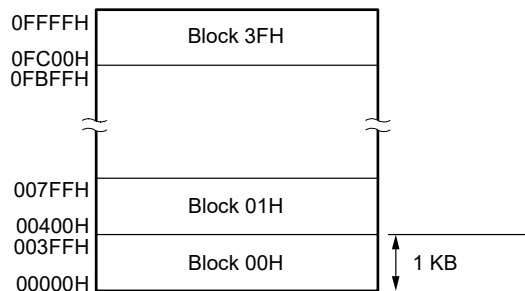

(R5F100xE, R5F101xE (x = 6 to 8, A to C, E to G, J, L))

Correspondence between the address values and block numbers in the flash memory are shown below.

Table 3-1. Correspondence Between Address Values and Block Numbers in Flash Memory (1/4)

Address Value	Block Number	Address Value	Block Number	Address Value	Block Number	Address Value	Block Number
00000H to 003FFH	00H	08000H to 083FFH	20H	10000H to 103FFH	40H	18000H to 183FFH	60H
00400H to 007FFH	01H	08400H to 087FFH	21H	10400H to 107FFH	41H	18400H to 187FFH	61H
00800H to 00BFFH	02H	08800H to 08BFFH	22H	10800H to 10BFFH	42H	18800H to 18BFFH	62H
00C00H to 00FFFH	03H	08C00H to 08FFFH	23H	10C00H to 10FFFH	43H	18C00H to 18FFFH	63H
01000H to 013FFH	04H	09000H to 093FFH	24H	11000H to 113FFH	44H	19000H to 193FFH	64H
01400H to 017FFH	05H	09400H to 097FFH	25H	11400H to 117FFH	45H	19400H to 197FFH	65H
01800H to 01BFFH	06H	09800H to 09BFFH	26H	11800H to 11BFFH	46H	19800H to 19BFFH	66H
01C00H to 01FFFH	07H	09C00H to 09FFFH	27H	11C00H to 11FFFH	47H	19C00H to 19FFFH	67H
02000H to 023FFH	08H	0A000H to 0A3FFH	28H	12000H to 123FFH	48H	1A000H to 1A3FFH	68H
02400H to 027FFH	09H	0A400H to 0A7FFH	29H	12400H to 127FFH	49H	1A400H to 1A7FFH	69H
02800H to 02BFFH	0AH	0A800H to 0ABFFH	2AH	12800H to 12BFFH	4AH	1A800H to 1ABFFH	6AH
02C00H to 02FFFH	0BH	0AC00H to 0AFFFH	2BH	12C00H to 12FFFH	4BH	1AC00H to 1AFFFH	6BH
03000H to 033FFH	0CH	0B000H to 0B3FFH	2CH	13000H to 133FFH	4CH	1B000H to 1B3FFH	6CH
03400H to 037FFH	0DH	0B400H to 0B7FFH	2DH	13400H to 137FFH	4DH	1B400H to 1B7FFH	6DH
03800H to 03BFFH	0EH	0B800H to 0BBFFH	2EH	13800H to 13BFFH	4EH	1B800H to 1BBFFH	6EH
03C00H to 03FFFH	0FH	0BC00H to 0BFFFH	2FH	13C00H to 13FFFH	4FH	1BC00H to 1BFFFH	6FH
04000H to 043FFH	10H	0C000H to 0C3FFH	30H	14000H to 143FFH	50H	1C000H to 1C3FFH	70H
04400H to 047FFH	11H	0C400H to 0C7FFH	31H	14400H to 147FFH	51H	1C400H to 1C7FFH	71H
04800H to 04BFFH	12H	0C800H to 0CBFFH	32H	14800H to 14BFFH	52H	1C800H to 1CBFFH	72H
04C00H to 04FFFH	13H	0CC00H to 0CFFFH	33H	14C00H to 14FFFH	53H	1CC00H to 1CFFFH	73H
05000H to 053FFH	14H	0D000H to 0D3FFH	34H	15000H to 153FFH	54H	1D000H to 1D3FFH	74H
05400H to 057FFH	15H	0D400H to 0D7FFH	35H	15400H to 157FFH	55H	1D400H to 1D7FFH	75H
05800H to 05BFFH	16H	0D800H to 0DBFFH	36H	15800H to 15BFFH	56H	1D800H to 1DBFFH	76H
05C00H to 05FFFH	17H	0DC00H to 0DFFFH	37H	15C00H to 15FFFH	57H	1DC00H to 1DFFFH	77H
06000H to 063FFH	18H	0E000H to 0E3FFH	38H	16000H to 163FFH	58H	1E000H to 1E3FFH	78H
06400H to 067FFH	19H	0E400H to 0E7FFH	39H	16400H to 167FFH	59H	1E400H to 1E7FFH	79H
06800H to 06BFFH	1AH	0E800H to 0EBFFH	3AH	16800H to 16BFFH	5AH	1E800H to 1EBFFH	7AH
06C00H to 06FFFH	1BH	0EC00H to 0EFFFH	3BH	16C00H to 16FFFH	5BH	1EC00H to 1EFFFH	7BH
07000H to 073FFH	1CH	0F000H to 0F3FFH	3CH	17000H to 173FFH	5CH	1F000H to 1F3FFH	7CH
07400H to 077FFH	1DH	0F400H to 0F7FFH	3DH	17400H to 177FFH	5DH	1F400H to 1F7FFH	7DH
07800H to 07BFFH	1EH	0F800H to 0FBFFH	3EH	17800H to 17BFFH	5EH	1F800H to 1FBFFH	7EH
07C00H to 07FFFH	1FH	0FC00H to 0FFFFH	3FH	17C00H to 17FFFH	5FH	1FC00H to 1FFFFH	7FH

Remark R5F100xA, R5F101xA (x = 6 to 8, A to C, E to G) : Block numbers 00H to 0FH
R5F100xC, R5F101xC (x = 6 to 8, A to C, E to G, J, L) : Block numbers 00H to 1FH
R5F100xD, R5F101xD (x = 6 to 8, A to C, E to G, J, L) : Block numbers 00H to 2FH
R5F100xE, R5F101xE (x = 6 to 8, A to C, E to G, J, L) : Block numbers 00H to 3FH
R5F100xF, R5F101xF (x = A to C, E to G, J, L, M, P) : Block numbers 00H to 5FH
R5F100xG, R5F101xG (x = A to C, E to G, J, L, M, P) : Block numbers 00H to 7FH

Table 3-1. Correspondence Between Address Values and Block Numbers in Flash Memory (2/4)

Address Value	Block Number	Address Value	Block Number	Address Value	Block Number	Address Value	Block Number
20000H to 203FFH	80H	28000H to 283FFH	A0H	30000H to 303FFH	C0H	38000H to 383FFH	E0H
20400H to 207FFH	81H	28400H to 287FFH	A1H	30400H to 307FFH	C1H	38400H to 387FFH	E1H
20800H to 20BFFH	82H	28800H to 28BFFH	A2H	30800H to 30BFFH	C2H	38800H to 38BFFH	E2H
20C00H to 20FFFH	83H	28C00H to 28FFFH	A3H	30C00H to 30FFFH	C3H	38C00H to 38FFFH	E3H
21000H to 213FFH	84H	29000H to 293FFH	A4H	31000H to 313FFH	C4H	39000H to 393FFH	E4H
21400H to 217FFH	85H	29400H to 297FFH	A5H	31400H to 317FFH	C5H	39400H to 397FFH	E5H
21800H to 21BFFH	86H	29800H to 29BFFH	A6H	31800H to 31BFFH	C6H	39800H to 39BFFH	E6H
21C00H to 21FFFH	87H	29C00H to 29FFFH	A7H	31C00H to 31FFFH	C7H	39C00H to 39FFFH	E7H
22000H to 223FFH	88H	2A000H to 2A3FFH	A8H	32000H to 323FFH	C8H	3A000H to 3A3FFH	E8H
22400H to 227FFH	89H	2A400H to 2A7FFH	A9H	32400H to 327FFH	C9H	3A400H to 3A7FFH	E9H
22800H to 22BFFH	8AH	2A800H to 2ABFFH	AAH	32800H to 32BFFH	CAH	3A800H to 3ABFFH	EAH
22C00H to 22FFFH	8BH	2AC00H to 2AFFFH	ABH	32C00H to 32FFFH	CBH	3AC00H to 3AFFFH	EBH
23000H to 233FFH	8CH	2B000H to 2B3FFH	ACH	33000H to 333FFH	CCH	3B000H to 3B3FFH	ECH
23400H to 237FFH	8DH	2B400H to 2B7FFH	ADH	33400H to 337FFH	CDH	3B400H to 3B7FFH	EDH
23800H to 23BFFH	8EH	2B800H to 2BBFFH	AEH	33800H to 33BFFH	CEH	3B800H to 3BBFFH	EEH
23C00H to 23FFFH	8FH	2BC00H to 2BFFFH	AFH	33C00H to 33FFFH	CFH	3BC00H to 3BFFFH	EFH
24000H to 243FFH	90H	2C000H to 2C3FFH	B0H	34000H to 343FFH	D0H	3C000H to 3C3FFH	F0H
24400H to 247FFH	91H	2C400H to 2C7FFH	B1H	34400H to 347FFH	D1H	3C400H to 3C7FFH	F1H
24800H to 24BFFH	92H	2C800H to 2CBFFH	B2H	34800H to 34BFFH	D2H	3C800H to 3CBFFH	F2H
24C00H to 24FFFH	93H	2CC00H to 2CFFFH	B3H	34C00H to 34FFFH	D3H	3CC00H to 3CFFFH	F3H
25000H to 253FFH	94H	2D000H to 2D3FFH	B4H	35000H to 353FFH	D4H	3D000H to 3D3FFH	F4H
25400H to 257FFH	95H	2D400H to 2D7FFH	B5H	35400H to 357FFH	D5H	3D400H to 3D7FFH	F5H
25800H to 25BFFH	96H	2D800H to 2DBFFH	B6H	35800H to 35BFFH	D6H	3D800H to 3DBFFH	F6H
25C00H to 25FFFH	97H	2DC00H to 2DFFFH	B7H	35C00H to 35FFFH	D7H	3DC00H to 3DFFFH	F7H
26000H to 263FFH	98H	2E000H to 2E3FFH	B8H	36000H to 363FFH	D8H	3E000H to 3E3FFH	F8H
26400H to 267FFH	99H	2E400H to 2E7FFH	B9H	36400H to 367FFH	D9H	3E400H to 3E7FFH	F9H
26800H to 26BFFH	9AH	2E800H to 2EBFFH	BAH	36800H to 36BFFH	DAH	3E800H to 3EBFFH	FAH
26C00H to 26FFFH	9BH	2EC00H to 2EFFFH	BBH	36C00H to 36FFFH	DBH	3EC00H to 3EFFFH	FBH
27000H to 273FFH	9CH	2F000H to 2F3FFH	BCH	37000H to 373FFH	DCH	3F000H to 3F3FFH	FCH
27400H to 277FFH	9DH	2F400H to 2F7FFH	BDH	37400H to 377FFH	DDH	3F400H to 3F7FFH	FDH
27800H to 27BFFH	9EH	2F800H to 2FBFFH	BEH	37800H to 37BFFH	DEH	3F800H to 3FBFFH	FEH
27C00H to 27FFFH	9FH	2FC00H to 2FFFFH	BFH	37C00H to 37FFFH	DFH	3FC00H to 3FFFFH	FFH

Remark R5F100xH, R5F101xH (x = E to G, J, L, M, P, S) : Block numbers 00H to BFH
R5F100xJ, R5F101xJ (x = F, G, J, L, M, P, S) : Block numbers 00H to FFH

Table 3-1. Correspondence Between Address Values and Block Numbers in Flash Memory (3/4)

Address Value	Block Number	Address Value	Block Number	Address Value	Block Number	Address Value	Block Number
40000H to 403FFH	100H	48000H to 483FFH	120H	50000H to 503FFH	140H	58000H to 583FFH	160H
40400H to 407FFH	101H	48400H to 487FFH	121H	50400H to 507FFH	141H	58400H to 587FFH	161H
40800H to 40BFFH	102H	48800H to 48BFFH	122H	50800H to 50BFFH	142H	58800H to 58BFFH	162H
40C00H to 40FFFH	103H	48C00H to 48FFFH	123H	50C00H to 50FFFH	143H	58C00H to 58FFFH	163H
41000H to 413FFH	104H	49000H to 493FFH	124H	51000H to 513FFH	144H	59000H to 593FFH	164H
41400H to 417FFH	105H	49400H to 497FFH	125H	51400H to 517FFH	145H	59400H to 597FFH	165H
41800H to 41BFFH	106H	49800H to 49BFFH	126H	51800H to 51BFFH	146H	59800H to 59BFFH	166H
41C00H to 41FFFH	107H	49C00H to 49FFFH	127H	51C00H to 51FFFH	147H	59C00H to 59FFFH	167H
42000H to 423FFH	108H	4A000H to 4A3FFH	128H	52000H to 523FFH	148H	5A000H to 5A3FFH	168H
42400H to 427FFH	109H	4A400H to 4A7FFH	129H	52400H to 527FFH	149H	5A400H to 5A7FFH	169H
42800H to 42BFFH	10AH	4A800H to 4ABFFH	12AH	52800H to 52BFFH	14AH	5A800H to 5ABFFH	16AH
42C00H to 42FFFH	10BH	4AC00H to 4AFFFH	12BH	52C00H to 52FFFH	14BH	5AC00H to 5AFFFH	16BH
43000H to 433FFH	10CH	4B000H to 4B3FFH	12CH	53000H to 533FFH	14CH	5B000H to 5B3FFH	16CH
43400H to 437FFH	10DH	4B400H to 4B7FFH	12DH	53400H to 537FFH	14DH	5B400H to 5B7FFH	16DH
43800H to 43BFFH	10EH	4B800H to 4BBFFH	12EH	53800H to 53BFFH	14EH	5B800H to 5BBFFH	16EH
43C00H to 43FFFH	10FH	4BC00H to 4BFFFH	12FH	53C00H to 53FFFH	14FH	5BC00H to 5BFFFH	16FH
44000H to 443FFH	110H	4C000H to 4C3FFH	130H	54000H to 543FFH	150H	5C000H to 5C3FFH	170H
44400H to 447FFH	111H	4C400H to 4C7FFH	131H	54400H to 547FFH	151H	5C400H to 5C7FFH	171H
44800H to 44BFFH	112H	4C800H to 4CBFFH	132H	54800H to 54BFFH	152H	5C800H to 5CBFFH	172H
44C00H to 44FFFH	113H	4CC00H to 4CFFFH	133H	54C00H to 54FFFH	153H	5CC00H to 5CFFFH	173H
45000H to 453FFH	114H	4D000H to 4D3FFH	134H	55000H to 553FFH	154H	5D000H to 5D3FFH	174H
45400H to 457FFH	115H	4D400H to 4D7FFH	135H	55400H to 557FFH	155H	5D400H to 5D7FFH	175H
45800H to 45BFFH	116H	4D800H to 4DBFFH	136H	55800H to 55BFFH	156H	5D800H to 5DBFFH	176H
45C00H to 45FFFH	117H	4DC00H to 4DFFFH	137H	55C00H to 55FFFH	157H	5DC00H to 5DFFFH	177H
46000H to 463FFH	118H	4E000H to 4E3FFH	138H	56000H to 563FFH	158H	5E000H to 5E3FFH	178H
46400H to 467FFH	119H	4E400H to 4E7FFH	139H	56400H to 567FFH	159H	5E400H to 5E7FFH	179H
46800H to 46BFFH	11AH	4E800H to 4EBFFH	13AH	56800H to 56BFFH	15AH	5E800H to 5EBFFH	17AH
46C00H to 46FFFH	11BH	4EC00H to 4EFFFH	13BH	56C00H to 56FFFH	15BH	5EC00H to 5EFFFH	17BH
47000H to 473FFH	11CH	4F000H to 4F3FFH	13CH	57000H to 573FFH	15CH	5F000H to 5F3FFH	17CH
47400H to 477FFH	11DH	4F400H to 4F7FFH	13DH	57400H to 577FFH	15DH	5F400H to 5F7FFH	17DH
47800H to 47BFFH	11EH	4F800H to 4FBFFH	13EH	57800H to 57BFFH	15EH	5F800H to 5FBFFH	17EH
47C00H to 47FFFH	11FH	4FC00H to 4FFFFH	13FH	57C00H to 57FFFH	15FH	5FC00H to 5FFFFH	17FH

Remark R5F100xK, R5F101xH (x = E to G, J, L, M, P, S) : Block numbers 00H to 17FH

Table 3-1. Correspondence Between Address Values and Block Numbers in Flash Memory (4/4)

Address Value	Block Number	Address Value	Block Number	Address Value	Block Number	Address Value	Block Number
60000H to 603FFH	180H	68000H to 683FFH	1A0H	70000H to 703FFH	1C0H	78000H to 783FFH	1E0H
60400H to 607FFH	181H	68400H to 687FFH	1A1H	70400H to 707FFH	1C1H	78400H to 787FFH	1E1H
60800H to 60BFFH	182H	68800H to 68BFFH	1A2H	70800H to 70BFFH	1C2H	78800H to 78BFFH	1E2H
60C00H to 60FFFH	183H	68C00H to 68FFFH	1A3H	70C00H to 70FFFH	1C3H	78C00H to 78FFFH	1E3H
61000H to 613FFH	184H	69000H to 693FFH	1A4H	71000H to 713FFH	1C4H	79000H to 793FFH	1E4H
61400H to 617FFH	185H	69400H to 697FFH	1A5H	71400H to 717FFH	1C5H	79400H to 797FFH	1E5H
61800H to 61BFFH	186H	69800H to 69BFFH	1A6H	71800H to 71BFFH	1C6H	79800H to 79BFFH	1E6H
61C00H to 61FFFH	187H	69C00H to 69FFFH	1A7H	71C00H to 71FFFH	1C7H	79C00H to 79FFFH	1E7H
62000H to 623FFH	188H	6A000H to 6A3FFH	1A8H	72000H to 723FFH	1C8H	7A000H to 7A3FFH	1E8H
62400H to 627FFH	189H	6A400H to 6A7FFH	1A9H	72400H to 727FFH	1C9H	7A400H to 7A7FFH	1E9H
62800H to 62BFFH	18AH	6A800H to 6ABFFH	1AAH	72800H to 72BFFH	1CAH	7A800H to 7ABFFH	1EAH
62C00H to 62FFFH	18BH	6AC00H to 6AFFFH	1ABH	72C00H to 72FFFH	1CBH	7AC00H to 7AFFFH	1EBH
63000H to 633FFH	18CH	6B000H to 6B3FFH	1ACH	73000H to 733FFH	1CCH	7B000H to 7B3FFH	1ECH
63400H to 637FFH	18DH	6B400H to 6B7FFH	1ADH	73400H to 737FFH	1CDH	7B400H to 7B7FFH	1EDH
63800H to 63BFFH	18EH	6B800H to 6BBFFH	1AEH	73800H to 73BFFH	1CEH	7B800H to 7BBFFH	1EEH
63C00H to 63FFFH	18FH	6BC00H to 6BFFFH	1AFH	73C00H to 73FFFH	1CFH	7BC00H to 7BFFFH	1EFH
64000H to 643FFH	190H	6C000H to 6C3FFH	1B0H	74000H to 743FFH	1D0H	7C000H to 7C3FFH	1F0H
64400H to 647FFH	191H	6C400H to 6C7FFH	1B1H	74400H to 747FFH	1D1H	7C400H to 7C7FFH	1F1H
64800H to 64BFFH	192H	6C800H to 6CBFFH	1B2H	74800H to 74BFFH	1D2H	7C800H to 7CBFFH	1F2H
64C00H to 64FFFH	193H	6CC00H to 6CFFFH	1B3H	74C00H to 74FFFH	1D3H	7CC00H to 7CFFFH	1F3H
65000H to 653FFH	194H	6D000H to 6D3FFH	1B4H	75000H to 753FFH	1D4H	7D000H to 7D3FFH	1F4H
65400H to 657FFH	195H	6D400H to 6D7FFH	1B5H	75400H to 757FFH	1D5H	7D400H to 7D7FFH	1F5H
65800H to 65BFFH	196H	6D800H to 6DBFFH	1B6H	75800H to 75BFFH	1D6H	7D800H to 7DBFFH	1F6H
65C00H to 65FFFH	197H	6DC00H to 6DFFFH	1B7H	75C00H to 75FFFH	1D7H	7DC00H to 7DFFFH	1F7H
66000H to 663FFH	198H	6E000H to 6E3FFH	1B8H	76000H to 763FFH	1D8H	7E000H to 7E3FFH	1F8H
66400H to 667FFH	199H	6E400H to 6E7FFH	1B9H	76400H to 767FFH	1D9H	7E400H to 7E7FFH	1F9H
66800H to 66BFFH	19AH	6E800H to 6EBFFH	1BAH	76800H to 76BFFH	1DAH	7E800H to 7EBFFH	1FAH
66C00H to 66FFFH	19BH	6EC00H to 6EFFFH	1BBH	76C00H to 76FFFH	1DBH	7EC00H to 7EFFFH	1FBH
67000H to 673FFH	19CH	6F000H to 6F3FFH	1BCH	77000H to 773FFH	1DCH	7F000H to 7F3FFH	1FCH
67400H to 677FFH	19DH	6F400H to 6F7FFH	1BDH	77400H to 777FFH	1DDH	7F400H to 7F7FFH	1FDH
67800H to 67BFFH	19EH	6F800H to 6FBFFH	1BEH	77800H to 77BFFH	1DEH	7F800H to 7FBFFH	1FEH
67C00H to 67FFFH	19FH	6FC00H to 6FFFFH	1BFH	77C00H to 77FFFH	1DFH	7FC00H to 7FFFFH	1FFH

Remark R5F100xL, R5F101xL (x = F, G, J, L, M, P, S) :

Block numbers 00H to 1FFH

3.1.1 Internal program memory space

The internal program memory space stores the program and table data.

The RL78/G13 products incorporate internal ROM (flash memory), as shown below.

Table 3-2. Internal ROM Capacity

Part Number	Internal ROM	
	Structure	Capacity
R5F100xA, R5F101xA (x = 6 to 8, A to C, E to G)	Flash memory	16384 × 8 bits (00000H to 03FFFFH)
R5F100xC, R5F101xC (x = 6 to 8, A to C, E to G, J, L)		32768 × 8 bits (00000H to 07FFFFH)
R5F100xD, R5F101xD (x = 6 to 8, A to C, E to G, J, L)		49152 × 8 bits (00000H to 0BFFFFH)
R5F100xE, R5F101xE (x = 6 to 8, A to C, E to G, J, L)		65536 × 8 bits (00000H to 0FFFFH)
R5F100xF, R5F101xF (x = A to C, E to G, J, L, M, P)		98304 × 8 bits (00000H to 17FFFFH)
R5F100xG, R5F101xG (x = A to C, E to G, J, L, M, P)		131072 × 8 bits (00000H to 1FFFFH)
R5F100xH, R5F101xH (x = E to G, J, L, M, P, S)		196608 × 8 bits (00000H to 2FFFFH)
R5F100xJ, R5F101xJ (x = F, G, J, L, M, P, S)		262144 × 8 bits (00000H to 3FFFFH)
R5F100xK, R5F101xK (x = F, G, J, L, M, P, S)		393216 × 8 bits (00000H to 5FFFFH)
R5F100xL, R5F101xL (x = F, G, J, L, M, P, S)		524288 × 8 bits (00000H to 7FFFFH)

The internal program memory space is divided into the following areas.

(1) Vector table area

The 128-byte area 00000H to 0007FH is reserved as a vector table area. The program start addresses for branch upon reset or generation of each interrupt request are stored in the vector table area. Furthermore, the interrupt jump address is a 64 K address of 00000H to 0FFFFH, because the vector code is assumed to be 2 bytes.

Of the 16-bit address, the lower 8 bits are stored at even addresses and the higher 8 bits are stored at odd addresses.

To use the boot swap function, set a vector table also at 01000H to 0107FH.

Table 3-3. Vector Table (1/2)

Vector Table Address	Interrupt Source	128-pin	100-pin	80-pin	64-pin	52-pin	48-pin	44-pin	40-pin	36-pin	32-pin	30-pin	25-pin	24-pin	20-pin
00000H	RESET, POR, LVD, WDT, TRAP, IAW, RPE	√	√	√	√	√	√	√	√	√	√	√	√	√	√
00004H	INTWDTI	√	√	√	√	√	√	√	√	√	√	√	√	√	√
00006H	INTLVI	√	√	√	√	√	√	√	√	√	√	√	√	√	√
00008H	INTP0	√	√	√	√	√	√	√	√	√	√	√	√	√	√
0000AH	INTP1	√	√	√	√	√	√	√	√	√	√	√	√	√	–
0000CH	INTP2	√	√	√	√	√	√	√	√	√	√	√	–	–	–
0000EH	INTP3	√	√	√	√	√	√	√	√	√	√	√	√	√	√
00010H	INTP4	√	√	√	√	√	√	√	√	√	√	√	√	√	–
00012H	INTP5	√	√	√	√	√	√	√	√	√	√	√	√	√	√
00014H	INTST2/INTCSI20/INTIIC20	√	√	√	√	√	√	√	√	√	√	√	–	–	–
00016H	INTSR2/INTCSI21/INTIIC21	√	√	√	√	√	√	√	√	√	Note 1	Note 1	–	–	–
00018H	INTSRE2	√	√	√	√	√	√	√	√	√	√	√	–	–	–
	INTTM11H	√	√	√	–	–	–	–	–	–	–	–	–	–	–
0001AH	INTDMA0	√	√	√	√	√	√	√	√	√	√	√	√	√	√
0001CH	INTDMA1	√	√	√	√	√	√	√	√	√	√	√	√	√	√
0001EH	INTST0/INTCSI00/INTIIC00	√	√	√	√	√	√	√	√	√	√	√	√	√	√
00020H	INTSR0/INTCSI01/INTIIC01	√	√	√	√	√	√	Note 2	Note 2	Note 2	Note 2	Note 2	Note 2	Note 2	Note 2
00022H	INTSRE0	√	√	√	√	√	√	√	√	√	√	√	√	√	√
	INTTM01H	√	√	√	√	√	√	√	√	√	√	√	√	√	√
00024H	INTST1/INTCSI10/INTIIC10	√	√	√	√	Note 3	Note 3	Note 3	Note 3	Note 3	Note 3	Note 3	Note 3	Note 3	Note 3
00026H	INTSR1/INTCSI11/INTIIC11	√	√	√	√	√	√	√	√	√	√	√	√	√	√
00028H	INTSRE1	√	√	√	√	√	√	√	√	√	√	√	√	√	√
	INTTM03H	√	√	√	√	√	√	√	√	√	√	√	√	√	√
0002AH	INTIICA0	√	√	√	√	√	√	√	√	√	√	√	√	√	–
0002CH	INTTM00	√	√	√	√	√	√	√	√	√	√	√	√	√	√
0002EH	INTTM01	√	√	√	√	√	√	√	√	√	√	√	√	√	√
00030H	INTTM02	√	√	√	√	√	√	√	√	√	√	√	√	√	√
00032H	INTTM03	√	√	√	√	√	√	√	√	√	√	√	√	√	√
00034H	INTAD	√	√	√	√	√	√	√	√	√	√	√	√	√	√
00036H	INTRTC	√	√	√	√	√	√	√	√	√	√	√	√	√	√
00038H	INTIT	√	√	√	√	√	√	√	√	√	√	√	√	√	√
0003AH	INTKR	√	√	√	√	√	√	√	√	–	–	–	–	–	–
0003CH	INTST3/INTCSI30/INTIIC30	√	√	√	–	–	–	–	–	–	–	–	–	–	–
0003EH	INTSR3/INTCSI31/INTIIC31	√	√	√	–	–	–	–	–	–	–	–	–	–	–
00040H	INTTM13	√	√	√	–	–	–	–	–	–	–	–	–	–	–

- Notes**
1. INTSR2 only.
 2. INTSR0 only.
 3. INTSR1 only.

Table 3-3. Vector Table (2/2)

Vector Table Address	Interrupt Source	128-pin	100-pin	80-pin	64-pin	52-pin	48-pin	44-pin	40-pin	36-pin	32-pin	30-pin	25-pin	24-pin	20-pin
00042H	INTTM04	√	√	√	√	√	√	√	√	√	√	√	√	√	√
00044H	INTTM05	√	√	√	√	√	√	√	√	√	√	√	√	√	√
00046H	INTTM06	√	√	√	√	√	√	√	√	√	√	√	√	√	√
00048H	INTTM07	√	√	√	√	√	√	√	√	√	√	√	√	√	√
0004AH	INTP6	√	√	√	√	√	√	-	-	-	-	-	-	-	-
0004CH	INTP7	√	√	√	√	-	-	-	-	-	-	-	-	-	-
0004EH	INTP8	√	√	√	√	√	√	-	-	-	-	-	-	-	-
00050H	INTP9	√	√	√	√	√	√	-	-	-	-	-	-	-	-
00052H	INTP10	√	√	√	√	√	-	-	-	-	-	-	-	-	-
00054H	INTP11	√	√	√	√	√	-	-	-	-	-	-	-	-	-
00056H	INTTM10	√	√	√	-	-	-	-	-	-	-	-	-	-	-
00058H	INTTM11	√	√	√	-	-	-	-	-	-	-	-	-	-	-
0005AH	INTTM12	√	√	√	-	-	-	-	-	-	-	-	-	-	-
0005CH	INTSRE3	√	√	√	-	-	-	-	-	-	-	-	-	-	-
	INTTM13H	√	√	√	-	-	-	-	-	-	-	-	-	-	-
0005EH	INTMD	√	√	√	√	√	√	√	√	√	√	√	√	√	√
00060H	INTIICA1	√	√	√	-	-	-	-	-	-	-	-	-	-	-
00062H	INTFL	√	√	√	√	√	√	√	√	√	√	√	√	√	√
00064H	INTDMA2	√	√	√	-	-	-	-	-	-	-	-	-	-	-
00066H	INTDMA3	√	√	√	-	-	-	-	-	-	-	-	-	-	-
00068H	INTTM14	√	-	-	-	-	-	-	-	-	-	-	-	-	-
0006AH	INTTM15	√	-	-	-	-	-	-	-	-	-	-	-	-	-
0006CH	INTTM16	√	-	-	-	-	-	-	-	-	-	-	-	-	-
0006EH	INTTM17	√	-	-	-	-	-	-	-	-	-	-	-	-	-
0007EH	BRK	√	√	√	√	√	√	√	√	√	√	√	√	√	√

(2) CALLT instruction table area

The 64-byte area 00080H to 000BFH can store the subroutine entry address of a 2-byte call instruction (CALLT). Set the subroutine entry address to a value in a range of 00000H to 0FFFFH (because an address code is of 2 bytes).

To use the boot swap function, set a CALLT instruction table also at 01080H to 010BFH.

(3) Option byte area

A 4-byte area of 000C0H to 000C3H can be used as an option byte area. Set the option byte at 010C0H to 010C3H when the boot swap is used. For details, see **CHAPTER 24 OPTION BYTE**.

(4) On-chip debug security ID setting area

A 10-byte area of 000C4H to 000CDH and 010C4H to 010CDH can be used as an on-chip debug security ID setting area. Set the on-chip debug security ID of 10 bytes at 000C4H to 000CDH when the boot swap is not used and at 000C4H to 000CDH and 010C4H to 010CDH when the boot swap is used. For details, see **CHAPTER 26 ON-CHIP DEBUG FUNCTION**.

3.1.2 Mirror area

The RL78/G13 mirrors the code flash area of 00000H to 0FFFFH, to F0000H to FFFFFH. The products with 96 KB or more flash memory mirror the code flash area of 00000H to 0FFFFH or 10000H to 1FFFFH, to F0000H to FFFFFH (the code flash area to be mirrored is set by the processor mode control register (PMC)).

By reading data from F0000H to FFFFFH, an instruction that does not have the ES register as an operand can be used, and thus the contents of the code flash can be read with the shorter code. However, the code flash area is not mirrored to the SFR, extended SFR, RAM, and use prohibited areas.

See **3.1 Memory Space** for the mirror area of each product.

The mirror area can only be read and no instruction can be fetched from this area.

The following show examples.

Example R5F100xE (x = 6 to 8, A to C, E-G, J, L) (Flash memory: 64 KB, RAM: 4 KB)

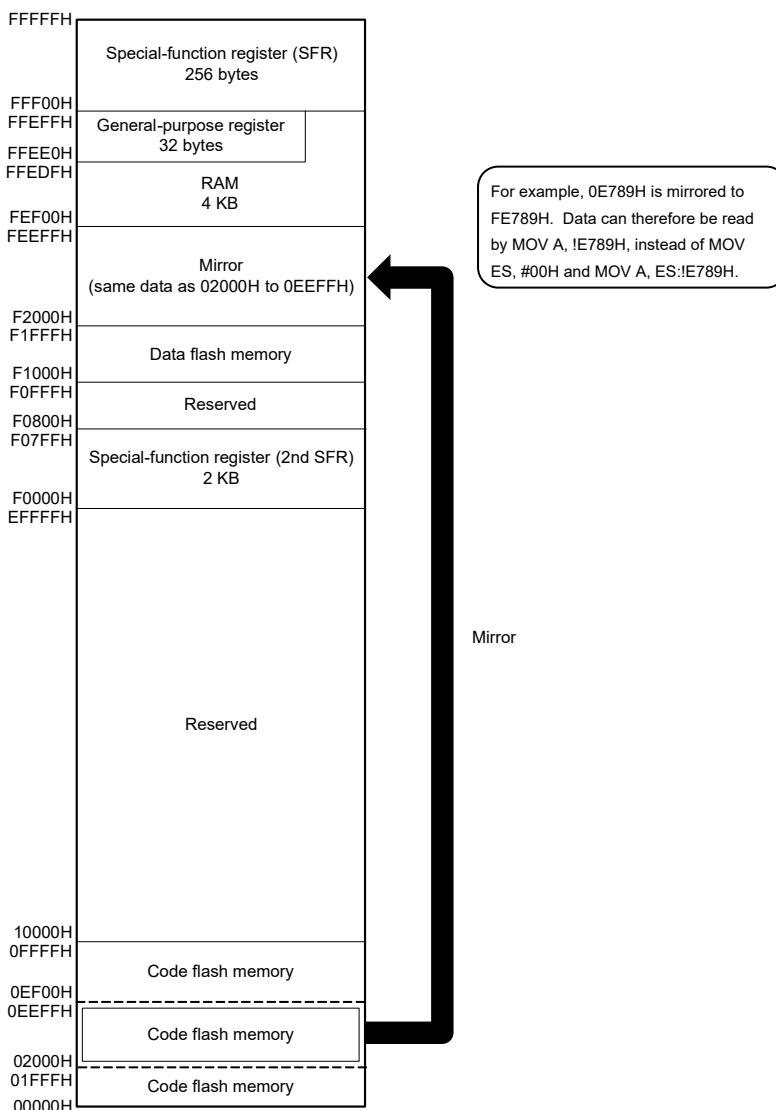

The PMC register is described below.

- **Processor mode control register (PMC)**

This register sets the flash memory space for mirroring to area from F0000H to FFFFFH.

The PMC register can be set by a 1-bit or 8-bit memory manipulation instruction.

Reset signal generation sets this register to 00H.

Figure 3-11. Format of Processor Mode Control Register (PMC)

Address: FFFFEH After reset: 00H R/W

Symbol	7	6	5	4	3	2	1	<0>
PMC	0	0	0	0	0	0	0	MAA

MAA	Selection of flash memory space for mirroring to area from F0000H to FFFFFH
0	00000H to 0FFFFH is mirrored to F0000H to FFFFFH
1	10000H to 1FFFFH is mirrored to F0000H to FFFFFH

- Cautions**
1. In products with 64 KB or less flash memory, be sure to clear bit 0 (MAA) of this register to 0 (default value).
 2. After setting the PMC register, wait for at least one instruction and access the mirror area.

3.1.3 Internal data memory space

The RL78/G13 products incorporate the following RAMs.

Table 3-4. Internal RAM Capacity

Part Number	Internal RAM
R5F100xA, R5F101xA (x = 6 to 8, A to C, E to G)	2048 × 8 bits (FF700H to FFEFFH)
R5F100xC, R5F101xC (x = 6 to 8, A to C, E to G, J, L)	
R5F100xD, R5F101xD (x = 6 to 8, A to C, E to G, J, L)	3072 × 8 bits (FF300H to FFEFFH)
R5F100xE, R5F101xE (x = 6 to 8, A to C, E to G, J, L)	4096 × 8 bits (FEF00H to FFEFFH)
R5F100xF, R5F101xF (x = A to C, E to G, J, L, M, P)	8192 × 8 bits (FDF00H to FFEFFH)
R5F100xG, R5F101xG (x = A to C, E to G, J, L, M, P)	12288 × 8 bits (FCF00H to FFEFFH)
R5F100xH, R5F101xH (x = E to G, J, L, M, P, S)	16384 × 8 bits (FBF00H to FFEFFH)
R5F100xJ, R5F101xJ (x = F, G, J, L, M, P, S)	20480 × 8 bits (FAF00H to FFEFFH)
R5F100xK, R5F101xK (x = F, G, J, L, M, P, S)	24576 × 8 bits (F9F00H to FFEFFH)
R5F100xL, R5F101xL (x = F, G, J, L, M, P, S)	32768 × 8 bits (F7F00H to FFEFFH)

The internal RAM can be used as a data area and a program area where instructions are fetched (it is prohibited to use the general-purpose register area for fetching instructions). Four general-purpose register banks consisting of eight 8-bit registers per bank are assigned to the 32-byte area of FFEE0H to FFEFFH of the internal RAM area.

The internal RAM is used as stack memory.

- Cautions**
1. It is prohibited to use the general-purpose register (FFEE0H to FFEFFH) space for fetching instructions or as a stack area.
 2. Do not allocate the stack area, data buffers for use by the flash library, arguments of library functions, branch destinations in the processing of vectored interrupts, or destinations or sources for DMA transfer to the area from FFE20H to FFEDFH when performing self-programming or rewriting of the data flash memory.
 3. The flash library uses RAM in self-programming and rewriting of the data flash memory.

The target products and start address of the RAM areas used by the flash library are shown below.

R5F100xD, R5F101xD (x = 6 to 8, A to C, E to G, J, L): Start address FF300H

R5F100xE, R5F101xE (x = 6 to 8, A to C, E to G, J, L): Start address FEF00H

R5F100xJ, R5F101xJ (x = F, G, J, L, M, P): Start address FAF00H

R5F100xL, R5F101xL (x = F, G, J, L, M, P, S): Start address F7F00H

For the RAM areas used by the flash library, see Self RAM list of Flash Self-Programming Library for RL78 Family (R20UT2944).

3.1.4 Special function register (SFR) area

On-chip peripheral hardware special function registers (SFRs) are allocated in the area FFF00H to FFFFFH (see **Table 3-5** in **3.2.4 Special function registers (SFRs)**).

Caution Do not access addresses to which SFRs are not assigned.

3.1.5 Extended special function register (2nd SFR: 2nd Special Function Register) area

On-chip peripheral hardware special function registers (2nd SFRs) are allocated in the area F0000H to F07FFH (see **Table 3-6** in **3.2.5 Extended Special function registers (2nd SFRs: 2nd Special Function Registers)**).

SFRs other than those in the SFR area (FFF00H to FFFFFH) are allocated to this area. An instruction that accesses the extended SFR area, however, is 1 byte longer than an instruction that accesses the SFR area.

Caution Do not access addresses to which extended SFRs are not assigned.

3.1.6 Data memory addressing

Addressing refers to the method of specifying the address of the instruction to be executed next or the address of the register or memory relevant to the execution of instructions.

Several addressing modes are provided for addressing the memory relevant to the execution of instructions for the RL78/G13, based on operability and other considerations. In particular, special addressing methods designed for the functions of the special function registers (SFR) and general-purpose registers are available for use. Figure 3-12 shows correspondence between data memory and addressing. For details of each addressing, see **3.4 Addressing for Processing Data Addresses**.

Figure 3-12. Correspondence Between Data Memory and Addressing

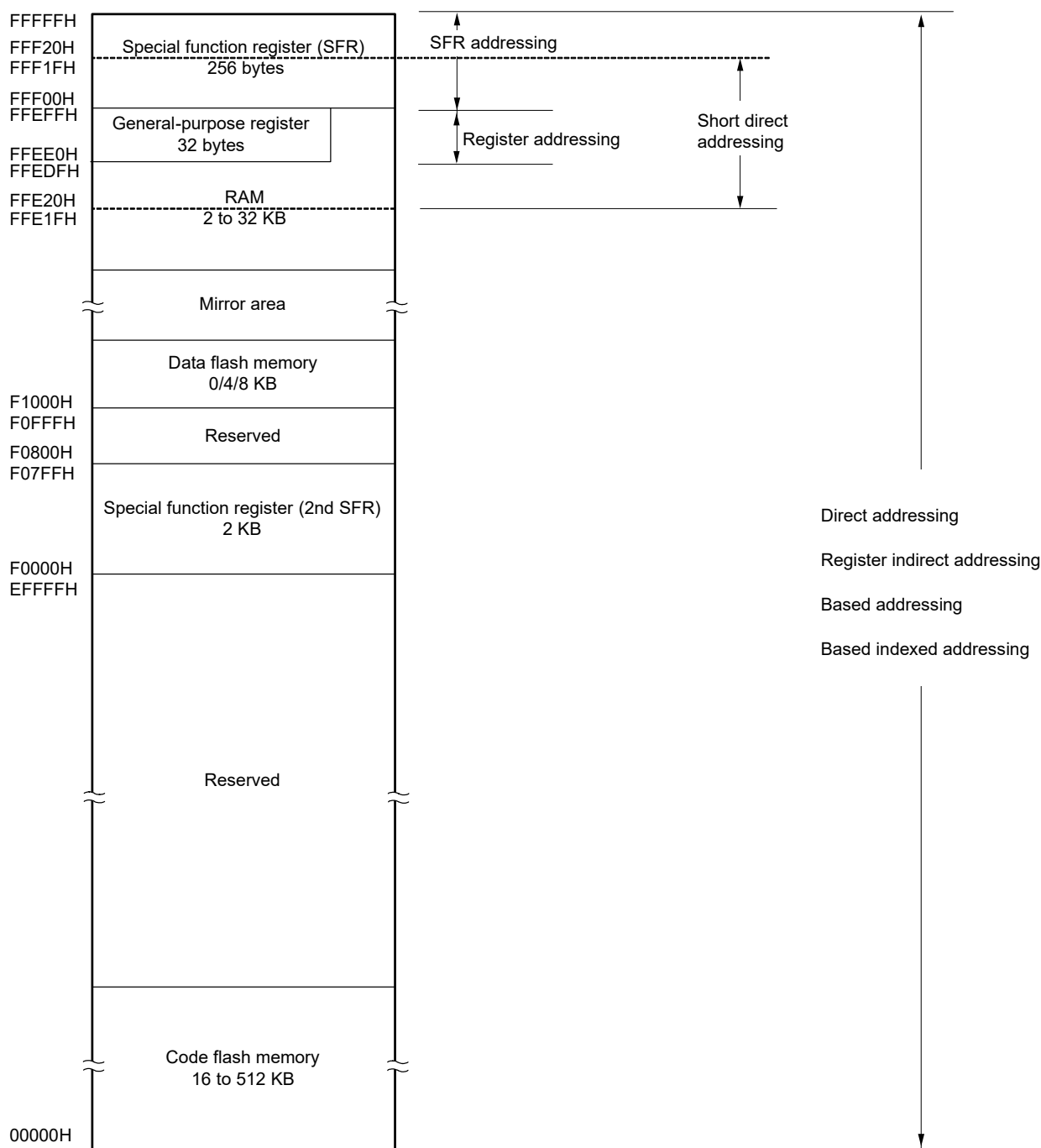

3.2 Processor Registers

The RL78/G13 products incorporate the following processor registers.

3.2.1 Control registers

The control registers control the program sequence, statuses and stack memory. The control registers consist of a program counter (PC), a program status word (PSW) and a stack pointer (SP).

(1) Program counter (PC)

The program counter is a 20-bit register that holds the address information of the next program to be executed. In normal operation, PC is automatically incremented according to the number of bytes of the instruction to be fetched. When a branch instruction is executed, immediate data and register contents are set. Reset signal generation sets the reset vector table values at addresses 00000H and 00001H to the 16 lower-order bits of the program counter. The four higher-order bits of the program counter are cleared to 0000.

Figure 3-13. Format of Program Counter

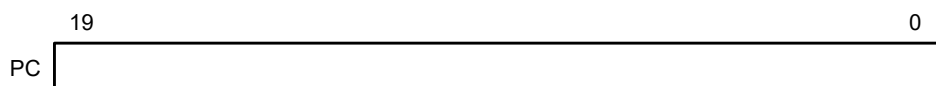

(2) Program status word (PSW)

The program status word is an 8-bit register consisting of various flags set/reset by instruction execution. Program status word contents are stored in the stack area upon vectored interrupt request is acknowledged or PUSH PSW instruction execution and are restored upon execution of the RETB, RETI and POP PSW instructions. Reset signal generation sets the PSW register to 06H.

Figure 3-14. Format of Program Status Word

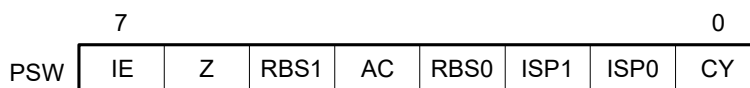

(a) Interrupt enable flag (IE)

This flag controls the interrupt request acknowledge operations of the CPU. When 0, the IE flag is set to the interrupt disabled (DI) state, and all maskable interrupt requests are disabled. When 1, the IE flag is set to the interrupt enabled (EI) state and maskable interrupt request acknowledgment is controlled with an in-service priority flag (ISP1, ISP0), an interrupt mask flag for various interrupt sources, and a priority specification flag. The IE flag is reset (0) upon DI instruction execution or interrupt acknowledgment and is set (1) upon EI instruction execution.

(b) Zero flag (Z)

When the operation or comparison result is zero or equal, this flag is set (1). It is reset (0) in all other cases.

(c) Register bank select flags (RBS0, RBS1)

These are 2-bit flags to select one of the four register banks. In these flags, the 2-bit information that indicates the register bank selected by SEL RBn instruction execution is stored.

(d) Auxiliary carry flag (AC)

If the operation result has a carry from bit 3 or a borrow at bit 3, this flag is set (1). It is reset (0) in all other cases.

(e) In-service priority flags (ISP1, ISP0)

This flag manages the priority of acknowledgeable maskable vectored interrupts. Vectored interrupt requests specified lower than the value of ISP0 and ISP1 flags by the priority specification flag registers (PRn0L, PRn0H, PRn1L, PRn1H, PRn2L, PRn2H, PRn3L) (see 16.3.3) can not be acknowledged. Actual vectored interrupt request acknowledgment is controlled by the interrupt enable flag (IE).

Remark n = 0, 1

(f) Carry flag (CY)

This flag stores overflow and underflow upon add/subtract instruction execution. It stores the shift-out value upon rotate instruction execution and functions as a bit accumulator during bit operation instruction execution.

(3) Stack pointer (SP)

This is a 16-bit register to hold the start address of the memory stack area. Only the internal RAM area can be set as the stack area.

Figure 3-15. Format of Stack Pointer

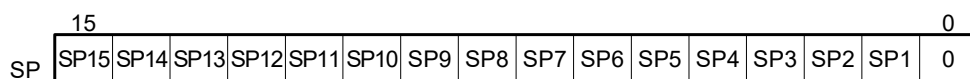

In stack addressing through a stack pointer, the SP is decremented ahead of write (save) to the stack memory and is incremented after read (restore) from the stack memory.

Cautions 1. Since reset signal generation makes the SP contents undefined, be sure to initialize the SP before using the stack.

2. It is prohibited to use the general-purpose register (FFEE0H to FFEFFH) space for fetching instructions or a stack area.

3. Do not allocate the stack area, data buffers for use by the flash library, arguments of library functions, branch destinations in the processing of vectored interrupts, or destinations or sources for DMA transfer to the area from FFE20H to FFEDFH when performing self-programming or rewriting of the data flash memory.

4. The flash library uses RAM in self-programming and rewriting of the data flash memory. The target products and start address of the RAM areas used by the flash library are shown below.

R5F100xD, R5F101xD (x = 6 to 8, A to C, E to G, J, L): Start address FF300H

R5F100xE, R5F101xE (x = 6 to 8, A to C, E to G, J, L): Start address FEF00H

R5F100xJ, R5F101xJ (x = F, G, J, L, M, P): Start address FAF00H

R5F100xL, R5F101xL (x = F, G, J, L, M, P, S): Start address F7F00H

For the RAM areas used by the flash library, see Self RAM list of Flash Self-Programming Library for RL78 Family (R20UT2944).

3.2.2 General-purpose registers

General-purpose registers are mapped at particular addresses (FFEE0H to FFEFFH) of the data memory. The general-purpose registers consists of 4 banks, each bank consisting of eight 8-bit registers (X, A, C, B, E, D, L, and H).

Each register can be used as an 8-bit register, and two 8-bit registers can also be used in a pair as a 16-bit register (AX, BC, DE, and HL).

Register banks to be used for instruction execution are set by the CPU control instruction (SEL RBn). Because of the 4-register bank configuration, an efficient program can be created by switching between a register for normal processing and a register for interrupt processing for each bank.

Caution It is prohibited to use the general-purpose register (FFEE0H to FFEFFH) space for fetching instructions or as a stack area.

Figure 3-16. Configuration of General-Purpose Registers

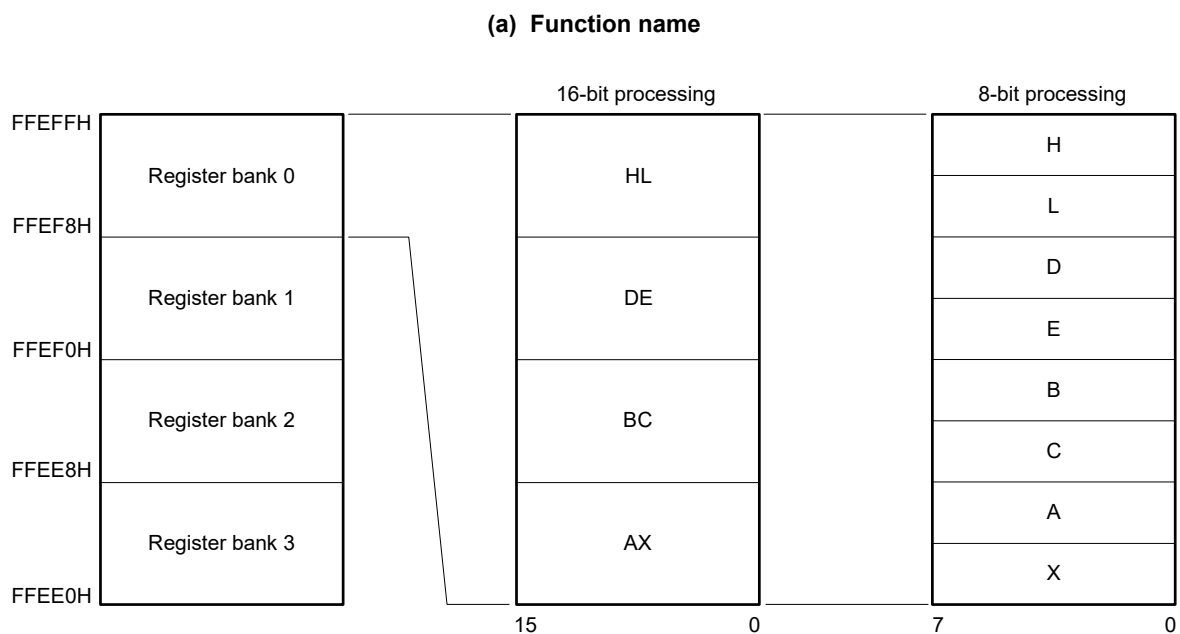

3.2.3 ES and CS registers

The ES register and CS register are used to specify the higher address for data access and when a branch instruction is executed (register indirect addressing), respectively.

The default value of the ES register after reset is 0FH, and that of the CS register is 00H.

Figure 3-17. Configuration of ES and CS Registers

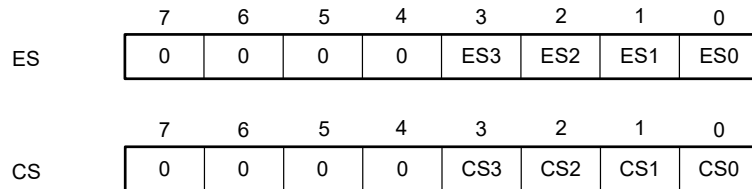

Though the data area which can be accessed with 16-bit addresses is the 64 Kbytes from F0000H to FFFFFH, using the ES register as well extends this to the 1 Mbyte from 00000H to FFFFFH.

Figure 3-18. Extension of Data Area Which Can Be Accessed

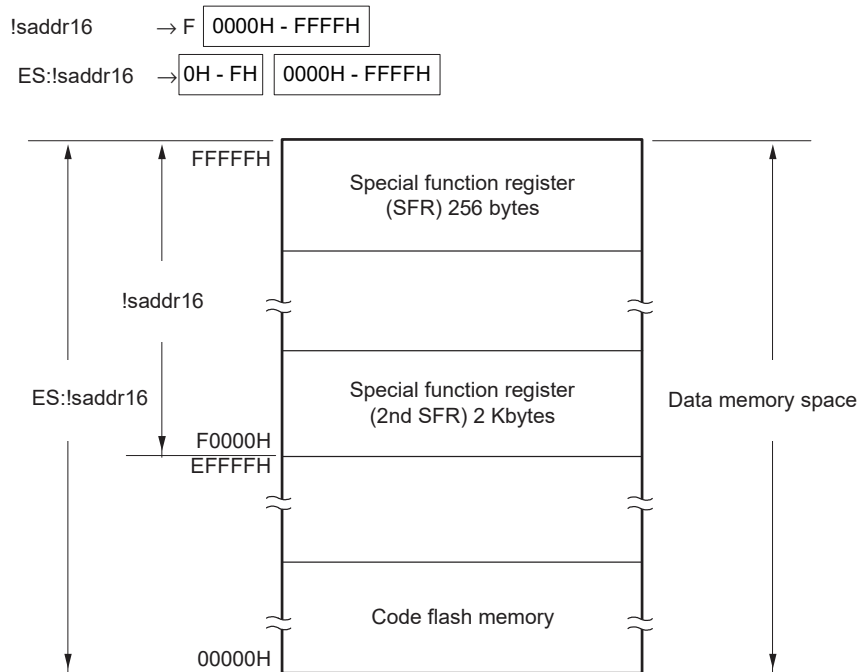

3.2.4 Special function registers (SFRs)

Unlike a general-purpose register, each SFR has a special function.

SFRs are allocated to the FFF00H to FFFFFH area.

SFRs can be manipulated like general-purpose registers, using operation, transfer, and bit manipulation instructions. The manipulable bit units, 1, 8, and 16, depend on the SFR type.

Each manipulation bit unit can be specified as follows.

- 1-bit manipulation

Describe as follows for the 1-bit manipulation instruction operand (sfr.bit).

When the bit name is defined: <Bit name>

When the bit name is not defined: <Register name>, <Bit number> or <Address>, <Bit number>

- 8-bit manipulation

Describe the symbol defined by the assembler for the 8-bit manipulation instruction operand (sfr). This manipulation can also be specified with an address.

- 16-bit manipulation

Describe the symbol defined by the assembler for the 16-bit manipulation instruction operand (sfrp). When specifying an address, describe an even address.

Table 3-5 gives a list of the SFRs. The meanings of items in the table are as follows.

- Symbol

Symbol indicating the address of a special function register. It is a reserved word in the assembler, and is defined as an sfr variable using the #pragma sfr directive in the compiler. When using the assembler, debugger, and simulator, symbols can be written as an instruction operand.

- R/W

Indicates whether the corresponding SFR can be read or written.

R/W: Read/write enable

R: Read only

W: Write only

- Manipulable bit units

“√” indicates the manipulable bit unit (1, 8, or 16). “-” indicates a bit unit for which manipulation is not possible.

- After reset

Indicates each register status upon reset signal generation.

Caution Do not access addresses to which extended SFRs are not assigned.

Remark For extended SFRs (2nd SFRs), see **3.2.5 Extended special function registers (2nd SFRs: 2nd Special Function Registers)**.

Table 3-5. SFR List (1/5)

Address	Special Function Register (SFR) Name	Symbol		R/W	Manipulable Bit Range			After Reset
					1-bit	8-bit	16-bit	
FFF00H	Port register 0	P0		R/W	√	√	–	00H
FFF01H	Port register 1	P1		R/W	√	√	–	00H
FFF02H	Port register 2	P2		R/W	√	√	–	00H
FFF03H	Port register 3	P3		R/W	√	√	–	00H
FFF04H	Port register 4	P4		R/W	√	√	–	00H
FFF05H	Port register 5	P5		R/W	√	√	–	00H
FFF06H	Port register 6	P6		R/W	√	√	–	00H
FFF07H	Port register 7	P7		R/W	√	√	–	00H
FFF08H	Port register 8	P8		R/W	√	√	–	00H
FFF09H	Port register 9	P9		R/W	√	√	–	00H
FFF0AH	Port register 10	P10		R/W	√	√	–	00H
FFF0BH	Port register 11	P11		R/W	√	√	–	00H
FFF0CH	Port register 12	P12		R/W	√	√	–	Undefined
FFF0DH	Port register 13	P13		R/W	√	√	–	Undefined
FFF0EH	Port register 14	P14		R/W	√	√	–	00H
FFF0FH	Port register 15	P15		R/W	√	√	–	00H
FFF10H	Serial data register 00	TXD0/ SIO00	SDR00	R/W	–	√	√	0000H
FFF11H		–			–	–		
FFF12H	Serial data register 01	RXD0/ SIO01	SDR01	R/W	–	√	√	0000H
FFF13H		–			–	–		
FFF14H	Serial data register 12	TXD3/ SIO30	SDR12	R/W	–	√	√	0000H
FFF15H		–			–	–		
FFF16H	Serial data register 13	RXD3/ SIO31	SDR13	R/W	–	√	√	0000H
FFF17H		–			–	–		
FFF18H	Timer data register 00	TDR00		R/W	–	–	√	0000H
FFF19H					–	–	–	
FFF1AH	Timer data register 01	TDR01L	TDR01	R/W	–	√	√	00H
FFF1BH		TDR01H			–	√	–	00H
FFF1EH	10-bit A/D conversion result register	ADCR		R	–	–	√	0000H
FFF1FH	8-bit A/D conversion result register	ADCRH		R	–	√	–	00H
FFF20H	Port mode register 0	PM0		R/W	√	√	–	FFH
FFF21H	Port mode register 1	PM1		R/W	√	√	–	FFH
FFF22H	Port mode register 2	PM2		R/W	√	√	–	FFH
FFF23H	Port mode register 3	PM3		R/W	√	√	–	FFH
FFF24H	Port mode register 4	PM4		R/W	√	√	–	FFH
FFF25H	Port mode register 5	PM5		R/W	√	√	–	FFH
FFF26H	Port mode register 6	PM6		R/W	√	√	–	FFH
FFF27H	Port mode register 7	PM7		R/W	√	√	–	FFH
FFF28H	Port mode register 8	PM8		R/W	√	√	–	FFH
FFF29H	Port mode register 9	PM9		R/W	√	√	–	FFH

Table 3-5. SFR List (2/5)

Address	Special Function Register (SFR) Name	Symbol		R/W	Manipulable Bit Range			After Reset
					1-bit	8-bit	16-bit	
FFF2AH	Port mode register 10	PM10		R/W	√	√	–	FFH
FFF2BH	Port mode register 11	PM11		R/W	√	√	–	FFH
FFF2CH	Port mode register 12	PM12		R/W	√	√	–	FFH
FFF2EH	Port mode register 14	PM14		R/W	√	√	–	FFH
FFF2FH	Port mode register 15	PM15		R/W	√	√	–	FFH
FFF30H	A/D converter mode register 0	ADM0		R/W	√	√	–	00H
FFF31H	Analog input channel specification register	ADS		R/W	√	√	–	00H
FFF32H	A/D converter mode register 1	ADM1		R/W	√	√	–	00H
FFF37H	Key return mode register	KRM		R/W	√	√	–	00H
FFF38H	External interrupt rising edge enable register 0	EGP0		R/W	√	√	–	00H
FFF39H	External interrupt falling edge enable register 0	EGN0		R/W	√	√	–	00H
FFF3AH	External interrupt rising edge enable register 1	EGP1		R/W	√	√	–	00H
FFF3BH	External interrupt falling edge enable register 1	EGN1		R/W	√	√	–	00H
FFF44H	Serial data register 02	TXD1/ SIO10	SDR02	R/W	–	√	√	0000H
FFF45H		–			–	–		
FFF46H	Serial data register 03	RXD1/ SIO11	SDR03	R/W	–	√	√	0000H
FFF47H		–			–	–		
FFF48H	Serial data register 10	TXD2/ SIO20	SDR10	R/W	–	√	√	0000H
FFF49H		–			–	–		
FFF4AH	Serial data register 11	RXD2/ SIO21	SDR11	R/W	–	√	√	0000H
FFF4BH		–			–	–		
FFF50H	IICA shift register 0	IICA0		R/W	–	√	–	00H
FFF51H	IICA status register 0	IICS0		R	√	√	–	00H
FFF52H	IICA flag register 0	IICF0		R/W	√	√	–	00H
FFF54H	IICA shift register 1	IICA1		R/W	–	√	–	00H
FFF55H	IICA status register 1	IICS1		R	√	√	–	00H
FFF56H	IICA flag register 1	IICF1		R/W	√	√	–	00H
FFF64H	Timer data register 02	TDR02		R/W	–	–	√	0000H
FFF65H								
FFF66H	Timer data register 03	TDR03L	TDR03	R/W	–	√	√	00H
FFF67H		TDR03H			–	√		
FFF68H	Timer data register 04	TDR04		R/W	–	–	√	0000H
FFF69H								

Table 3-5. SFR List (3/5)

Address	Special Function Register (SFR) Name	Symbol		R/W	Manipulable Bit Range			After Reset
					1-bit	8-bit	16-bit	
FFF6AH	Timer data register 05	TDR05		R/W	-	-	√	0000H
FFF6BH								
FFF6CH	Timer data register 06	TDR06		R/W	-	-	√	0000H
FFF6DH								
FFF6EH	Timer data register 07	TDR07		R/W	-	-	√	0000H
FFF6FH								
FFF70H	Timer data register 10	TDR10		R/W	-	-	√	0000H
FFF71H								
FFF72H	Timer data register 11	TDR11L	TDR11	R/W	-	√	√	00H
FFF73H		TDR11H						-
FFF74H	Timer data register 12	TDR12		R/W	-	-	√	0000H
FFF75H								
FFF76H	Timer data register 13	TDR13L	TDR13	R/W	-	√	√	00H
FFF77H		TDR13H						-
FFF78H	Timer data register 14	TDR14		R/W	-	-	√	0000H
FFF79H								
FFF7AH	Timer data register 15	TDR15		R/W	-	-	√	0000H
FFF7BH								
FFF7CH	Timer data register 16	TDR16		R/W	-	-	√	0000H
FFF7DH								
FFF7EH	Timer data register 17	TDR17		R/W	-	-	√	0000H
FFF7FH								
FFF90H	Interval timer control register	ITMC		R/W	-	-	√	0FFFH
FFF91H								
FFF92H	Second count register	SEC		R/W	-	√	-	00H
FFF93H	Minute count register	MIN		R/W	-	√	-	00H
FFF94H	Hour count register	HOUR		R/W	-	√	-	12H ^{Note}
FFF95H	Week count register	WEEK		R/W	-	√	-	00H
FFF96H	Day count register	DAY		R/W	-	√	-	01H
FFF97H	Month count register	MONTH		R/W	-	√	-	01H
FFF98H	Year count register	YEAR		R/W	-	√	-	00H
FFF99H	Watch error correction register	SUBCUD		R/W	-	√	-	00H
FFF9AH	Alarm minute register	ALARMWMM		R/W	-	√	-	00H
FFF9BH	Alarm hour register	ALARMWH		R/W	-	√	-	12H
FFF9CH	Alarm week register	ALARMWW		R/W	-	√	-	00H
FFF9DH	Real-time clock control register 0	RTCC0		R/W	√	√	-	00H
FFF9EH	Real-time clock control register 1	RTCC1		R/W	√	√	-	00H

Note The value of this register is 00H if the AMPM bit (bit 3 of real-time clock control register 0 (RTCC0)) is set to 1 after reset.

Table 3-5. SFR List (4/5)

Address	Special Function Register (SFR) Name	Symbol	R/W	Manipulable Bit Range			After Reset
				1-bit	8-bit	16-bit	
FFFA0H	Clock operation mode control register	CMC	R/W	–	√	–	00H
FFFA1H	Clock operation status control register	CSC	R/W	√	√	–	C0H
FFFA2H	Oscillation stabilization time counter status register	OSTC	R	√	√	–	00H
FFFA3H	Oscillation stabilization time select register	OSTS	R/W	–	√	–	07H
FFFA4H	System clock control register	CKC	R/W	√	√	–	00H
FFFA5H	Clock output select register 0	CKS0	R/W	√	√	–	00H
FFFA6H	Clock output select register 1	CKS1	R/W	√	√	–	00H
FFFA8H	Reset control flag register	RESF	R	–	√	–	Undefined ^{Note 1}
FFFA9H	Voltage detection register	LVIM	R/W	√	√	–	00H ^{Note 1}
FFFAAH	Voltage detection level register	LVIS	R/W	√	√	–	00H/01H/81H ^{Note 1}
FFFABH	Watchdog timer enable register	WDTE	R/W	–	√	–	1AH/9AH ^{Note 2}
FFFACH	CRC input register	CRCIN	R/W	–	√	–	00H
FFFB0H	DMA SFR address register 0	DSA0	R/W	–	√	–	00H
FFFB1H	DMA SFR address register 1	DSA1	R/W	–	√	–	00H
FFFB2H	DMA RAM address register 0	DRA0L	DRA0	R/W	–	√	√
FFFB3H		DRA0H		R/W	–	√	
FFFB4H	DMA RAM address register 1	DRA1L	DRA1	R/W	–	√	√
FFFB5H		DRA1H		R/W	–	√	
FFFB6H	DMA byte count register 0	DBC0L	DBC0	R/W	–	√	√
FFFB7H		DBC0H		R/W	–	√	
FFFB8H	DMA byte count register 1	DBC1L	DBC1	R/W	–	√	√
FFFB9H		DBC1H		R/W	–	√	
FFFBAAH	DMA mode control register 0	DMC0	R/W	√	√	–	00H
FFFBBAH	DMA mode control register 1	DMC1	R/W	√	√	–	00H
FFFBCH	DMA operation control register 0	DRC0	R/W	√	√	–	00H
FFFBDAH	DMA operation control register 1	DRC1	R/W	√	√	–	00H
FFFD0H	Interrupt request flag register 2	IF2L	IF2	R/W	√	√	√
FFFD1H		IF2H		R/W	√	√	
FFFD2H	Interrupt request flag register 3L	IF3L	IF3	R/W	√	√	√
FFFD4H	Interrupt mask flag register 2	MK2L	MK2	R/W	√	√	√
FFFD5H		MK2H		R/W	√	√	
FFFD6H	Interrupt mask flag register 3L	MK3L	MK3	R/W	√	√	√

(Notes are listed on the next page.)

Notes 1. The reset values of the registers vary depending on the reset source as shown below.

Reset Source		$\overline{\text{RESET}}$ Input	Reset by POR	Reset by Execution of Illegal Instruction	Reset by WDT	Reset by RAM parity error	Reset by illegal-memory access	Reset by LVD	
RESF	TRAP bit	Cleared (0)		Set (1)	Held			Held	
	WDTRF bit			Held	Set (1)	Held			
	RPERF bit			Held		Set (1)	Held		
	IAWRF bit			Held			Set (1)		
	LVIRF bit			Held					
LVIM	LVISEN bit	Cleared (0)						Held	
	LVIOMSK bit	Held							
	LVIF bit								
LVIS		Cleared (00H/01H/81H)							

2. The reset value of the WDTE register is determined by the setting of the option byte.

Table 3-5. SFR List (5/5)

Address	Special Function Register (SFR) Name	Symbol		R/W	Manipulable Bit Range			After Reset
					1-bit	8-bit	16-bit	
FFFD8H	Priority specification flag register 02	PR02L	PR02	R/W	√	√	√	FFH
FFFD9H		PR02H		R/W	√	√		FFH
FFFDAH	Priority specification flag register 03L	PR03L	PR03	R/W	√	√	√	FFH
FFFDCH	Priority specification flag register 12	PR12L	PR12	R/W	√	√	√	FFH
FFDDH		PR12H		R/W	√	√		FFH
FFFDEH	Priority specification flag register 13L	PR13L	PR13	R/W	√	√	√	FFH
FFFE0H	Interrupt request flag register 0	IF0L	IF0	R/W	√	√	√	00H
FFFE1H		IF0H		R/W	√	√		00H
FFFE2H	Interrupt request flag register 1	IF1L	IF1	R/W	√	√	√	00H
FFFE3H		IF1H		R/W	√	√		00H
FFFE4H	Interrupt mask flag register 0	MK0L	MK0	R/W	√	√	√	FFH
FFFE5H		MK0H		R/W	√	√		FFH
FFFE6H	Interrupt mask flag register 1	MK1L	MK1	R/W	√	√	√	FFH
FFFE7H		MK1H		R/W	√	√		FFH
FFFE8H	Priority specification flag register 00	PR00L	PR00	R/W	√	√	√	FFH
FFFE9H		PR00H		R/W	√	√		FFH
FFFEAH	Priority specification flag register 01	PR01L	PR01	R/W	√	√	√	FFH
FFFEBH		PR01H		R/W	√	√		FFH
FFFECH	Priority specification flag register 10	PR10L	PR10	R/W	√	√	√	FFH
FF FEDH		PR10H		R/W	√	√		FFH
FFFE EH	Priority specification flag register 11	PR11L	PR11	R/W	√	√	√	FFH
FFFE FH		PR11H		R/W	√	√		FFH
FFFF0H	Multiplication/division data register A (L)	MDAL		R/W	-	-	√	0000H
FFFF1H								
FFFF2H	Multiplication/division data register A (H)	MDAH		R/W	-	-	√	0000H
FFFF3H								
FFFF4H	Multiplication/division data register B (H)	MDBH		R/W	-	-	√	0000H
FFFF5H								
FFFF6H	Multiplication/division data register B (L)	MDBL		R/W	-	-	√	0000H
FFFF7H								
FFFEH	Processor mode control register	PMC		R/W	√	√	-	00H

Remark For extended SFRs (2nd SFRs), see Table 3-6 Extended SFR (2nd SFR) List.

3.2.5 Extended special function registers (2nd SFRs: 2nd Special Function Registers)

Unlike a general-purpose register, each extended SFR (2nd SFR) has a special function.

Extended SFRs are allocated to the F0000H to F07FFH area. SFRs other than those in the SFR area (FFF00H to FFFFFH) are allocated to this area. An instruction that accesses the extended SFR area, however, is 1 byte longer than an instruction that accesses the SFR area.

Extended SFRs can be manipulated like general-purpose registers, using operation, transfer, and bit manipulation instructions. The manipulable bit units, 1, 8, and 16, depend on the SFR type.

Each manipulation bit unit can be specified as follows.

- 1-bit manipulation
 - Describe as follows for the 1-bit manipulation instruction operand (!addr16.bit)
 - When the bit name is defined: <Bit name>
 - When the bit name is not defined: <Register name>, <Bit number> or <Address>, <Bit number>
- 8-bit manipulation
 - Describe the symbol defined by the assembler for the 8-bit manipulation instruction operand (!addr16). This manipulation can also be specified with an address.
- 16-bit manipulation
 - Describe the symbol defined by the assembler for the 16-bit manipulation instruction operand (!addr16). When specifying an address, describe an even address.

Table 3-6 gives a list of the extended SFRs. The meanings of items in the table are as follows.

- Symbol
 - Symbol indicating the address of an extended SFR. It is a reserved word in the assembler, and is defined as an sfr variable using the #pragma sfr directive in the compiler. When using the assembler, debugger, and simulator, symbols can be written as an instruction operand.
- R/W
 - Indicates whether the corresponding extended SFR can be read or written.
 - R/W: Read/write enable
 - R: Read only
 - W: Write only
- Manipulable bit units
 - “√” indicates the manipulable bit unit (1, 8, or 16). “–” indicates a bit unit for which manipulation is not possible.
- After reset
 - Indicates each register status upon reset signal generation.

Caution Do not access addresses to which extended SFRs (2nd SFRs) are not assigned.

Remark For SFRs in the SFR area, see 3.2.4 Special function registers (SFRs).

Table 3-6. Extended SFR (2nd SFR) List (1/8)

Address	Special Function Register (SFR) Name	Symbol	R/W	Manipulable Bit Range			After Reset
				1-bit	8-bit	16-bit	
F0010H	A/D converter mode register 2	ADM2	R/W	√	√	–	00H
F0011H	Conversion result comparison upper limit setting register	ADUL	R/W	–	√	–	FFH
F0012H	Conversion result comparison lower limit setting register	ADLL	R/W	–	√	–	00H
F0013H	A/D test register	ADTES	R/W	–	√	–	00H
F0030H	Pull-up resistor option register 0	PU0	R/W	√	√	–	00H
F0031H	Pull-up resistor option register 1	PU1	R/W	√	√	–	00H
F0033H	Pull-up resistor option register 3	PU3	R/W	√	√	–	00H
F0034H	Pull-up resistor option register 4	PU4	R/W	√	√	–	01H
F0035H	Pull-up resistor option register 5	PU5	R/W	√	√	–	00H
F0036H	Pull-up resistor option register 6	PU6	R/W	√	√	–	00H
F0037H	Pull-up resistor option register 7	PU7	R/W	√	√	–	00H
F0038H	Pull-up resistor option register 8	PU8	R/W	√	√	–	00H
F0039H	Pull-up resistor option register 9	PU9	R/W	√	√	–	00H
F003AH	Pull-up resistor option register 10	PU10	R/W	√	√	–	00H
F003BH	Pull-up resistor option register 11	PU11	R/W	√	√	–	00H
F003CH	Pull-up resistor option register 12	PU12	R/W	√	√	–	00H
F003EH	Pull-up resistor option register 14	PU14	R/W	√	√	–	00H
F0040H	Port input mode register 0	PIM0	R/W	√	√	–	00H
F0041H	Port input mode register 1	PIM1	R/W	√	√	–	00H
F0044H	Port input mode register 4	PIM4	R/W	√	√	–	00H
F0045H	Port input mode register 5	PIM5	R/W	√	√	–	00H
F0048H	Port input mode register 8	PIM8	R/W	√	√	–	00H
F004EH	Port input mode register 14	PIM14	R/W	√	√	–	00H
F0050H	Port output mode register 0	POM0	R/W	√	√	–	00H
F0051H	Port output mode register 1	POM1	R/W	√	√	–	00H
F0054H	Port output mode register 4	POM4	R/W	√	√	–	00H
F0055H	Port output mode register 5	POM5	R/W	√	√	–	00H
F0057H	Port output mode register 7	POM7	R/W	√	√	–	00H
F0058H	Port output mode register 8	POM8	R/W	√	√	–	00H
F0059H	Port output mode register 9	POM9	R/W	√	√	–	00H
F005EH	Port output mode register 14	POM14	R/W	√	√	–	00H
F0060H	Port mode control register 0	PMC0	R/W	√	√	–	FFH
F0063H	Port mode control register 3	PMC3	R/W	√	√	–	FFH
F006AH	Port mode control register 10	PMC10	R/W	√	√	–	FFH
F006BH	Port mode control register 11	PMC11	R/W	√	√	–	FFH
F006CH	Port mode control register 12	PMC12	R/W	√	√	–	FFH
F006EH	Port mode control register 14	PMC14	R/W	√	√	–	FFH

Table 3-6. Extended SFR (2nd SFR) List (2/8)

Address	Special Function Register (SFR) Name	Symbol	R/W	Manipulable Bit Range			After Reset	
				1-bit	8-bit	16-bit		
F0070H	Noise filter enable register 0	NFEN0	R/W	√	√	–	00H	
F0071H	Noise filter enable register 1	NFEN1	R/W	√	√	–	00H	
F0072H	Noise filter enable register 2	NFEN2	R/W	√	√	–	00H	
F0073H	Input switch control register	ISC	R/W	√	√	–	00H	
F0074H	Timer input select register 0	TIS0	R/W	–	√	–	00H	
F0076H	A/D port configuration register	ADPC	R/W	–	√	–	00H	
F0077H	Peripheral I/O redirection register	PIOR	R/W	–	√	–	00H	
F0078H	Invalid memory access detection control register	IAWCTL	R/W	–	√	–	00H	
F007DH	Global digital input disable register	GDIDIS	R/W	√	√	–	00H	
F0090H	Data flash control register	DFLCTL	R/W	√	√	–	00H	
F00A0H	High-speed on-chip oscillator trimming register	HOTRM	R/W	–	√	–	Undefined ^{Note1}	
F00A8H	High-speed on-chip oscillator frequency select register	HOCODIV	R/W	–	√	–	Undefined ^{Note2}	
F00E0H	Multiplication/division data register C (L)	MDCL	R/W	–	–	√	0000H	
F00E2H	Multiplication/division data register C (H)	MDCH	R/W	–	–	√	0000H	
F00E8H	Multiplication/division control register	MDUC	R/W	√	√	–	00H	
F00F0H	Peripheral enable register 0	PER0	R/W	√	√	–	00H	
F00F3H	Subsystem clock supply mode control register	OSMC	R/W	–	√	–	00H	
F00F5H	RAM parity error control register	RPECTL	R/W	√	√	–	00H	
F00FEH	BCD adjust result register	BCDADJ	R	–	√	–	Undefined	
F0100H	Serial status register 00	SSR00L	SSR00	R	–	√	√	0000H
F0101H		–		–	–			
F0102H	Serial status register 01	SSR01L	SSR01	R	–	√	√	0000H
F0103H		–		–	–			
F0104H	Serial status register 02	SSR02L	SSR02	R	–	√	√	0000H
F0105H		–		–	–			
F0106H	Serial status register 03	SSR03L	SSR03	R	–	√	√	0000H
F0107H		–		–	–			
F0108H	Serial flag clear trigger register 00	SIR00L	SIR00	R/W	–	√	√	0000H
F0109H		–		–	–			
F010AH	Serial flag clear trigger register 01	SIR01L	SIR01	R/W	–	√	√	0000H
F010BH		–		–	–			
F010CH	Serial flag clear trigger register 02	SIR02L	SIR02	R/W	–	√	√	0000H
F010DH		–		–	–			
F010EH	Serial flag clear trigger register 03	SIR03L	SIR03	R/W	–	√	√	0000H
F010FH		–		–	–			

Notes 1. The value after a reset is adjusted at the time of shipment.

2. The value after a reset is a value set in FRQSEL2 to FRQSEL0 of the option byte (000C2H).

Table 3-6. Extended SFR (2nd SFR) List (3/8)

Address	Special Function Register (SFR) Name	Symbol		R/W	Manipulable Bit Range			After Reset
					1-bit	8-bit	16-bit	
F0110H	Serial mode register 00	SMR00		R/W	–	–	√	0020H
F0111H								
F0112H	Serial mode register 01	SMR01		R/W	–	–	√	0020H
F0113H								
F0114H	Serial mode register 02	SMR02		R/W	–	–	√	0020H
F0115H								
F0116H	Serial mode register 03	SMR03		R/W	–	–	√	0020H
F0117H								
F0118H	Serial communication operation setting register 00	SCR00		R/W	–	–	√	0087H
F0119H								
F011AH	Serial communication operation setting register 01	SCR01		R/W	–	–	√	0087H
F011BH								
F011CH	Serial communication operation setting register 02	SCR02		R/W	–	–	√	0087H
F011DH								
F011EH	Serial communication operation setting register 03	SCR03		R/W	–	–	√	0087H
F011FH								
F0120H	Serial channel enable status register 0	SE0L	SE0	R	√	√	√	0000H
F0121H		–			–	–		
F0122H	Serial channel start register 0	SS0L	SS0	R/W	√	√	√	0000H
F0123H		–			–	–		
F0124H	Serial channel stop register 0	ST0L	ST0	R/W	√	√	√	0000H
F0125H		–			–	–		
F0126H	Serial clock select register 0	SPS0L	SPS0	R/W	–	√	√	0000H
F0127H		–			–	–		
F0128H	Serial output register 0	SO0		R/W	–	–	√	0F0FH
F0129H								
F012AH	Serial output enable register 0	SOE0L	SOE0	R/W	√	√	√	0000H
F012BH		–			–	–		
F0134H	Serial output level register 0	SOL0L	SOL0	R/W	–	√	√	0000H
F0135H		–			–	–		
F0138H	Serial standby control register 0	SSC0L	SSC0	R/W	–	√	√	0000H
F0139H		–			–	–		
F0140H	Serial status register 10	SSR10L	SSR10	R	–	√	√	0000H
F0141H		–			–	–		
F0142H	Serial status register 11	SSR11L	SSR11	R	–	√	√	0000H
F0143H		–			–	–		
F0144H	Serial status register 12	SSR12L	SSR12	R	–	√	√	0000H
F0145H		–			–	–		
F0146H	Serial status register 13	SSR13L	SSR13	R	–	√	√	0000H
F0147H		–			–	–		

Table 3-6. Extended SFR (2nd SFR) List (4/8)

Address	Special Function Register (SFR) Name	Symbol		R/W	Manipulable Bit Range			After Reset
					1-bit	8-bit	16-bit	
F0148H	Serial flag clear trigger register 10	SIR10L	SIR10	R/W	–	√	√	0000H
F0149H		–			–			
F014AH	Serial flag clear trigger register 11	SIR11L	SIR11	R/W	–	√	√	0000H
F014BH		–			–			
F014CH	Serial flag clear trigger register 12	SIR12L	SIR12	R/W	–	√	√	0000H
F014DH		–			–			
F014EH	Serial flag clear trigger register 13	SIR13L	SIR13	R/W	–	√	√	0000H
F014FH		–			–			
F0150H	Serial mode register 10	SMR10		R/W	–	–	√	0020H
F0151H					–	–		
F0152H	Serial mode register 11	SMR11		R/W	–	–	√	0020H
F0153H					–	–		
F0154H	Serial mode register 12	SMR12		R/W	–	–	√	0020H
F0155H					–	–		
F0156H	Serial mode register 13	SMR13		R/W	–	–	√	0020H
F0157H					–	–		
F0158H	Serial communication operation setting register 10	SCR10		R/W	–	–	√	0087H
F0159H					–	–		
F015AH	Serial communication operation setting register 11	SCR11		R/W	–	–	√	0087H
F015BH					–	–		
F015CH	Serial communication operation setting register 12	SCR12		R/W	–	–	√	0087H
F015DH					–	–		
F015EH	Serial communication operation setting register 13	SCR13		R/W	–	–	√	0087H
F015FH					–	–		
F0160H	Serial channel enable status register 1	SE1L	SE1	R	√	√	√	0000H
F0161H		–			–			
F0162H	Serial channel start register 1	SS1L	SS1	R/W	√	√	√	0000H
F0163H		–			–			
F0164H	Serial channel stop register 1	ST1L	ST1	R/W	√	√	√	0000H
F0165H		–			–			
F0166H	Serial clock select register 1	SPS1L	SPS1	R/W	–	√	√	0000H
F0167H		–			–			
F0168H	Serial output register 1	SO1		R/W	–	–	√	0F0FH
F0169H					–	–		
F016AH	Serial output enable register 1	SOE1L	SOE1	R/W	√	√	√	0000H
F016BH		–			–			
F0174H	Serial output level register 1	SOL1L	SOL1	R/W	–	√	√	0000H
F0175H		–			–			
F0178H	Serial standby control register 1	SSC1L	SSC1	R/W	–	√	√	0000H
		–			–			

Table 3-6. Extended SFR (2nd SFR) List (5/8)

Address	Special Function Register (SFR) Name	Symbol	R/W	Manipulable Bit Range			After Reset
				1-bit	8-bit	16-bit	
F0180H	Timer counter register 00	TCR00	R	-	-	√	FFFFH
F0181H							
F0182H	Timer counter register 01	TCR01	R	-	-	√	FFFFH
F0183H							
F0184H	Timer counter register 02	TCR02	R	-	-	√	FFFFH
F0185H							
F0186H	Timer counter register 03	TCR03	R	-	-	√	FFFFH
F0187H							
F0188H	Timer counter register 04	TCR04	R	-	-	√	FFFFH
F0189H							
F018AH	Timer counter register 05	TCR05	R	-	-	√	FFFFH
F018BH							
F018CH	Timer counter register 06	TCR06	R	-	-	√	FFFFH
F018DH							
F018EH	Timer counter register 07	TCR07	R	-	-	√	FFFFH
F018FH							
F0190H	Timer mode register 00	TMR00	R/W	-	-	√	0000H
F0191H							
F0192H	Timer mode register 01	TMR01	R/W	-	-	√	0000H
F0193H							
F0194H	Timer mode register 02	TMR02	R/W	-	-	√	0000H
F0195H							
F0196H	Timer mode register 03	TMR03	R/W	-	-	√	0000H
F0197H							
F0198H	Timer mode register 04	TMR04	R/W	-	-	√	0000H
F0199H							
F019AH	Timer mode register 05	TMR05	R/W	-	-	√	0000H
F019BH							
F019CH	Timer mode register 06	TMR06	R/W	-	-	√	0000H
F019DH							
F019EH	Timer mode register 07	TMR07	R/W	-	-	√	0000H
F019FH							
F01A0H	Timer status register 00	TSR00L	TSR00	R	-	√	0000H
F01A1H		-			-		
F01A2H	Timer status register 01	TSR01L	TSR01	R	-	√	0000H
F01A3H		-			-		

Table 3-6. Extended SFR (2nd SFR) List (6/8)

Address	Special Function Register (SFR) Name	Symbol		R/W	Manipulable Bit Range			After Reset
					1-bit	8-bit	16-bit	
F01A4H	Timer status register 02	TSR02L	TSR02	R	–	√	√	0000H
F01A5H		–			–			
F01A6H	Timer status register 03	TSR03L	TSR03	R	–	√	√	0000H
F01A7H		–			–			
F01A8H	Timer status register 04	TSR04L	TSR04	R	–	√	√	0000H
F01A9H		–			–			
F01AAH	Timer status register 05	TSR05L	TSR05	R	–	√	√	0000H
F01ABH		–			–			
F01ACH	Timer status register 06	TSR06L	TSR06	R	–	√	√	0000H
F01ADH		–			–			
F01AEH	Timer status register 07	TSR07L	TSR07	R	–	√	√	0000H
F01AFH		–			–			
F01B0H	Timer channel enable status register 0	TE0L	TE0	R	√	√	√	0000H
F01B1H		–			–			
F01B2H	Timer channel start register 0	TS0L	TS0	R/W	√	√	√	0000H
F01B3H		–			–			
F01B4H	Timer channel stop register 0	TT0L	TT0	R/W	√	√	√	0000H
F01B5H		–			–			
F01B6H	Timer clock select register 0	TPS0		R/W	–	–	√	0000H
F01B7H								
F01B8H	Timer output register 0	TO0L	TO0	R/W	–	√	√	0000H
F01B9H		–			–			
F01BAH	Timer output enable register 0	TOE0L	TOE0	R/W	√	√	√	0000H
F01BBH		–			–			
F01BCH	Timer output level register 0	TOL0L	TOL0	R/W	–	√	√	0000H
F01BDH		–			–			
F01BEH	Timer output mode register 0	TOM0L	TOM0	R/W	–	√	√	0000H
F01BFH		–			–			
F01C0H	Timer counter register 10	TCR10		R	–	–	√	FFFFH
F01C1H								
F01C2H	Timer counter register 11	TCR11		R	–	–	√	FFFFH
F01C3H								
F01C4H	Timer counter register 12	TCR12		R	–	–	√	FFFFH
F01C5H								
F01C6H	Timer counter register 13	TCR13		R	–	–	√	FFFFH
F01C7H								

Table 3-6. Extended SFR (2nd SFR) List (7/8)

Address	Special Function Register (SFR) Name	Symbol		R/W	Manipulable Bit Range			After Reset
					1-bit	8-bit	16-bit	
F01C8H	Timer counter register 14	TCR14		R	–	–	√	FFFFH
F01C9H								
F01CAH	Timer counter register 15	TCR15		R	–	–	√	FFFFH
F01CBH								
F01CCH	Timer counter register 16	TCR16		R	–	–	√	FFFFH
F01CDH								
F01CEH	Timer counter register 17	TCR17		R	–	–	√	FFFFH
F01CFH								
F01D0H	Timer mode register 10	TMR10		R/W	–	–	√	0000H
F01D1H								
F01D2H	Timer mode register 11	TMR11		R/W	–	–	√	0000H
F01D3H								
F01D4H	Timer mode register 12	TMR12		R/W	–	–	√	0000H
F01D5H								
F01D6H	Timer mode register 13	TMR13		R/W	–	–	√	0000H
F01D7H								
F01D8H	Timer mode register 14	TMR14		R/W	–	–	√	0000H
F01D9H								
F01DAH	Timer mode register 15	TMR15		R/W	–	–	√	0000H
F01DBH								
F01DCH	Timer mode register 16	TMR16		R/W	–	–	√	0000H
F01DDH								
F01DEH	Timer mode register 17	TMR17		R/W	–	–	√	0000H
F01DFH								
F01E0H	Timer status register 10	TSR10L	TSR10	R	–	√	√	0000H
F01E1H		–			–			
F01E2H	Timer status register 11	TSR11L	TSR11	R	–	√	√	0000H
F01E3H		–			–			
F01E4H	Timer status register 12	TSR12L	TSR12	R	–	√	√	0000H
F01E5H		–			–			
F01E6H	Timer status register 13	TSR13L	TSR13	R	–	√	√	0000H
F01E7H		–			–			
F01E8H	Timer status register 14	TSR14L	TSR14	R	–	√	√	0000H
F01E9H		–			–			
F01EAH	Timer status register 15	TSR15L	TSR15	R	–	√	√	0000H
F01EBH		–			–			
F01ECH	Timer status register 16	TSR16L	TSR16	R	–	√	√	0000H
F01EDH		–			–			
F01EEH	Timer status register 17	TSR17L	TSR17	R	–	√	√	0000H
F01EFH		–			–			
F01F0H	Timer channel enable status register 1	TE1L	TE1	R	√	√	√	0000H
F01F1H		–			–			
F01F2H	Timer channel start register 1	TS1L	TS1	R/W	√	√	√	0000H
F01F3H		–			–			

Table 3-6. Extended SFR (2nd SFR) List (8/8)

Address	Special Function Register (SFR) Name	Symbol		R/W	Manipulable Bit Range			After Reset
					1-bit	8-bit	16-bit	
F01F4H	Timer channel stop register 1	TT1L	TT1	R/W	√	√	√	0000H
F01F5H		–			–			
F01F6H	Timer clock select register 1	TPS1		R/W	–	–	√	0000H
F01F7H								
F01F8H	Timer output register 1	TO1L	TO1	R/W	–	√	√	0000H
F01F9H		–			–			
F01FAH	Timer output enable register 1	TOE1L	TOE1	R/W	√	√	√	0000H
F01FBH		–			–			
F01FCH	Timer output level register 1	TOL1L	TOL1	R/W	–	√	√	0000H
F01FDH		–			–			
F01FEH	Timer output mode register 1	TOM1L	TOM1	R/W	–	√	√	0000H
F01FFH		–			–			
F0200H	DMA SFR address register 2	DSA2		R/W	–	√	–	00H
F0201H	DMA SFR address register 3	DSA3		R/W	–	√	–	00H
F0202H	DMA RAM address register 2	DRA2L	DRA2	R/W	–	√	√	00H
F0203H		DRA2H		R/W	–	√		
F0204H	DMA RAM address register 3	DRA3L	DRA3	R/W	–	√	√	00H
F0205H		DRA3H		R/W	–	√		
F0206H	DMA byte count register 2	DBC2L	DBC2	R/W	–	√	√	00H
F0207H		DBC2H		R/W	–	√		
F0208H	DMA byte count register 3	DBC3L	DBC3	R/W	–	√	√	00H
F0209H		DBC3H		R/W	–	√		
F020AH	DMA mode control register 2	DMC2		R/W	√	√	–	00H
F020BH	DMA mode control register 3	DMC3		R/W	√	√	–	00H
F020CH	DMA operation control register 2	DRC2		R/W	√	√	–	00H
F020DH	DMA operation control register 3	DRC3		R/W	√	√	–	00H
F0230H	IICA control register 00	IICCTL00		R/W	√	√	–	00H
F0231H	IICA control register 01	IICCTL01		R/W	√	√	–	00H
F0232H	IICA low-level width setting register 0	IICWL0		R/W	–	√	–	FFH
F0233H	IICA high-level width setting register 0	IICWH0		R/W	–	√	–	FFH
F0234H	Slave address register 0	SVA0		R/W	–	√	–	00H
F0238H	IICA control register 10	IICCTL10		R/W	√	√	–	00H
F0239H	IICA control register 11	IICCTL11		R/W	√	√	–	00H
F023AH	IICA low-level width setting register 1	IICWL1		R/W	–	√	–	FFH
F023BH	IICA high-level width setting register 1	IICWH1		R/W	–	√	–	FFH
F023CH	Slave address register 1	SVA1		R/W	–	√	–	00H
F02F0H	Flash memory CRC control register	CRC0CTL		R/W	√	√	–	00H
F02F2H	Flash memory CRC operation result register	PGCRCL		R/W	–	–	√	0000H
F02FAH	CRC data register	CRCD		R/W	–	–	√	0000H

Remark For SFRs in the SFR area, see Table 3-5 SFR List.

3.3 Instruction Address Addressing

3.3.1 Relative addressing

[Function]

Relative addressing stores in the program counter (PC) the result of adding a displacement value included in the instruction word (signed complement data: -128 to +127 or -32768 to +32767) to the program counter (PC)'s value (the start address of the next instruction), and specifies the program address to be used as the branch destination. Relative addressing is applied only to branch instructions.

Figure 3-19. Outline of Relative Addressing

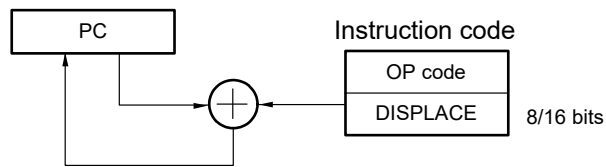

3.3.2 Immediate addressing

[Function]

Immediate addressing stores immediate data of the instruction word in the program counter, and specifies the program address to be used as the branch destination.

For immediate addressing, CALL !!addr20 or BR !!addr20 is used to specify 20-bit addresses and CALL !addr16 or BR !addr16 is used to specify 16-bit addresses. 0000 is set to the higher 4 bits when specifying 16-bit addresses.

Figure 3-20. Example of CALL !!addr20/BR !!addr20

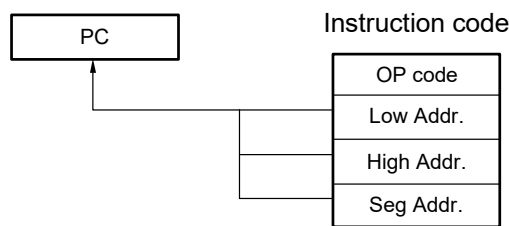
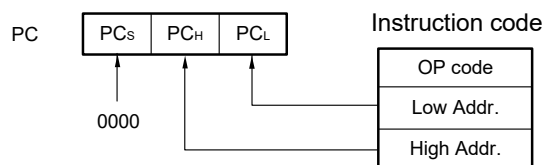

Figure 3-21. Example of CALL !addr16/BR !addr16



3.3.3 Table indirect addressing

[Function]

Table indirect addressing specifies a table address in the CALLT table area (0080H to 00BFH) with the 5-bit immediate data in the instruction word, stores the contents at that table address and the next address in the program counter (PC) as 16-bit data, and specifies the program address. Table indirect addressing is applied only for CALLT instructions.

In the RL78 microcontrollers, branching is enabled only to the 64 KB space from 00000H to 0FFFFH.

Figure 3-22. Outline of Table Indirect Addressing

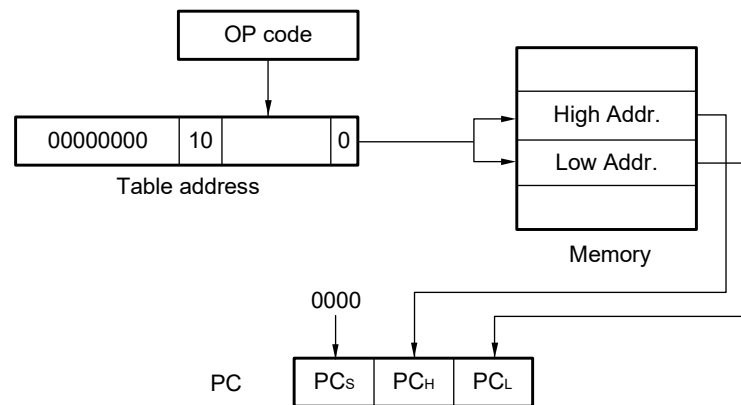

3.3.4 Register indirect addressing

[Function]

Register indirect addressing stores in the program counter (PC) the contents of a general-purpose register pair (AX/BC/DE/HL) and CS register of the current register bank specified with the instruction word as 20-bit data, and specifies the program address. Register indirect addressing can be applied only to the CALL AX, BC, DE, HL, and BR AX instructions.

Figure 3-23. Outline of Register Indirect Addressing

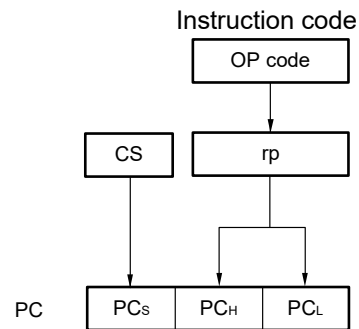

3.4 Addressing for Processing Data Addresses

3.4.1 Implied addressing

[Function]

Instructions for accessing registers (such as accumulators) that have special functions are directly specified with the instruction word, without using any register specification field in the instruction word.

[Operand format]

Because implied addressing can be automatically employed with an instruction, no particular operand format is necessary.

Implied addressing can be applied only to MULU X.

Figure 3-24. Outline of Implied Addressing

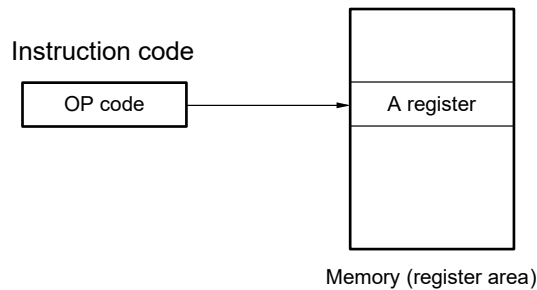

3.4.2 Register addressing

[Function]

Register addressing accesses a general-purpose register as an operand. The instruction word of 3-bit long is used to select an 8-bit register and the instruction word of 2-bit long is used to select a 16-bit register.

[Operand format]

Identifier	Description
r	X, A, C, B, E, D, L, H
rp	AX, BC, DE, HL

Figure 3-25. Outline of Register Addressing

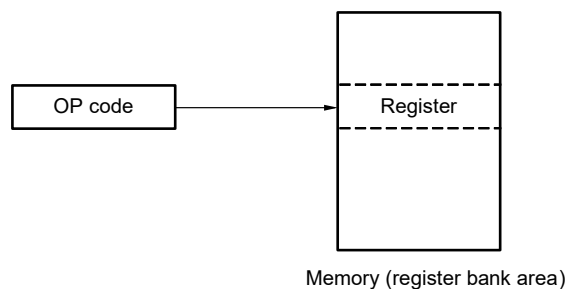

3.4.3 Direct addressing

[Function]

Direct addressing uses immediate data in the instruction word as an operand address to directly specify the target address.

[Operand format]

Identifier	Description
!addr16	Label or 16-bit immediate data (only the space from F0000H to FFFFFH is specifiable)
ES:!addr16	Label or 16-bit immediate data (higher 4-bit addresses are specified by the ES register)

Figure 3-26. Example of !addr16

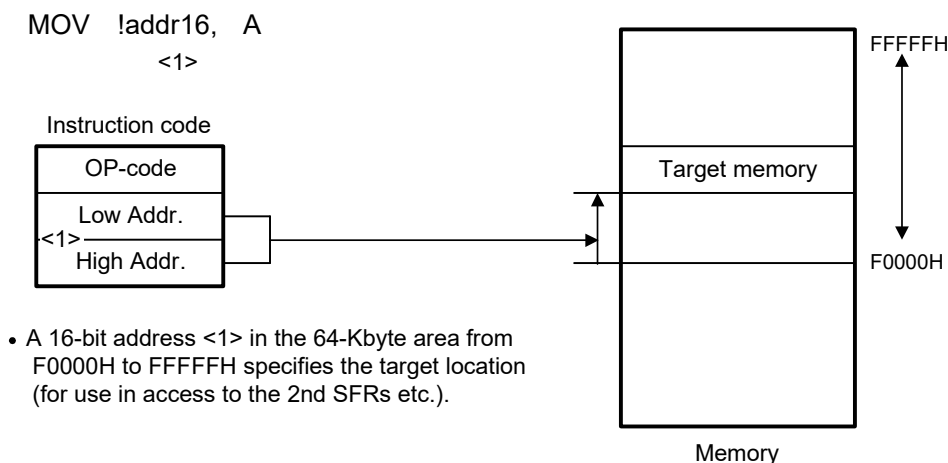
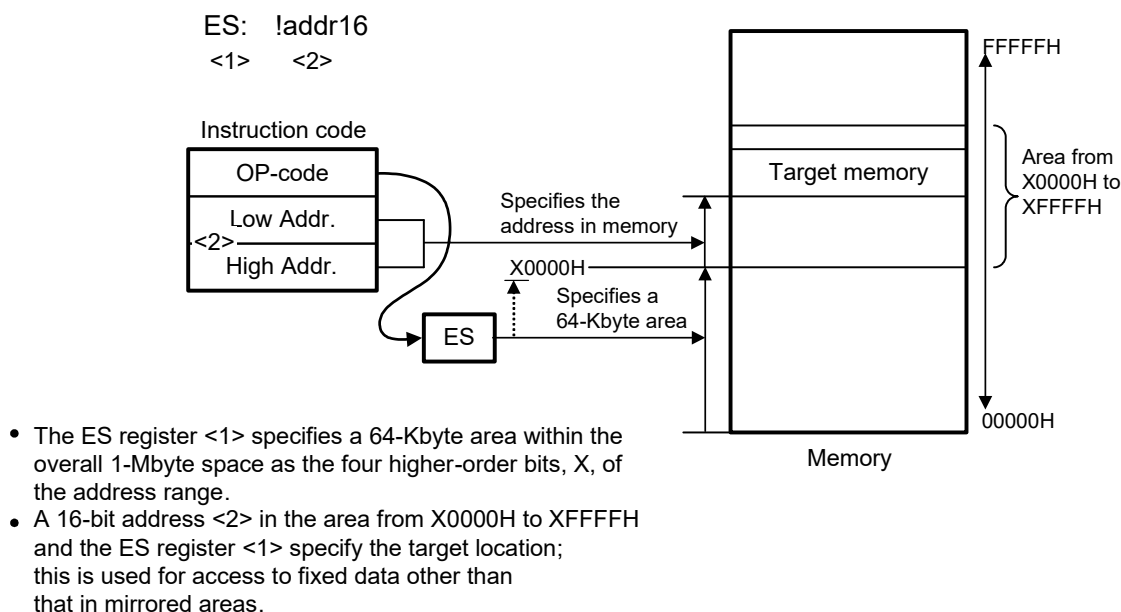

Figure 3-27. Example of ES:!addr16



3.4.4 Short direct addressing

[Function]

Short direct addressing directly specifies the target addresses using 8-bit data in the instruction word. This type of addressing is applied only to the space from FFE20H to FFF1FH.

[Operand format]

Identifier	Description
SADDR	Label, FFE20H to FFF1FH immediate data, or 0FE20H to 0FF1FH immediate data (only the space from FFE20H to FFF1FH is specifiable)
SADDRP	Label, FFE20H to FFF1FH immediate data, or 0FE20H to 0FF1FH immediate data (even address only) (only the space from FFE20H to FFF1FH is specifiable)

Figure 3-28. Outline of Short Direct Addressing

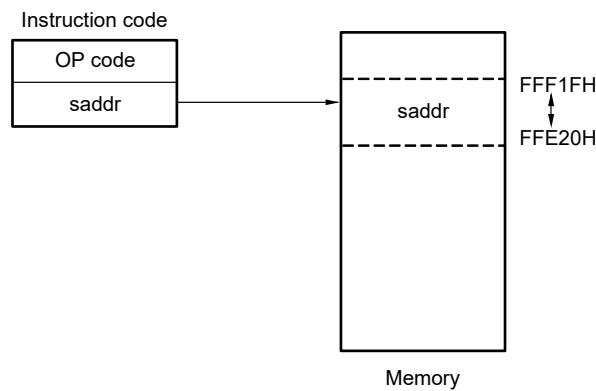

Remark SADDR and SADDRP are used to describe the values of addresses FE20H to FF1FH with 16-bit immediate data (higher 4 bits of actual address are omitted), and the values of addresses FFE20H to FFF1FH with 20-bit immediate data.

Regardless of whether SADDR or SADDRP is used, addresses within the space from FFE20H to FFF1FH are specified for the memory.

3.4.5 SFR addressing

[Function]

SFR addressing directly specifies the target SFR addresses using 8-bit data in the instruction word. This type of addressing is applied only to the space from FFF00H to FFFFFH.

[Operand format]

Identifier	Description
SFR	SFR name
SFRP	16-bit-manipulatable SFR name (even address)

Figure 3-29. Outline of SFR Addressing

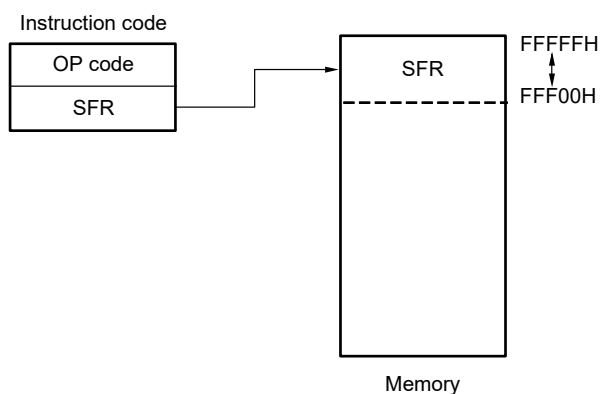

3.4.6 Register indirect addressing

[Function]

Register indirect addressing directly specifies the target addresses using the contents of the register pair specified with the instruction word as an operand address.

[Operand format]

Identifier	Description
-	[DE], [HL] (only the space from F0000H to FFFFFH is specifiable)
-	ES:[DE], ES:[HL] (higher 4-bit addresses are specified by the ES register)

Figure 3-30. Example of [DE], [HL]

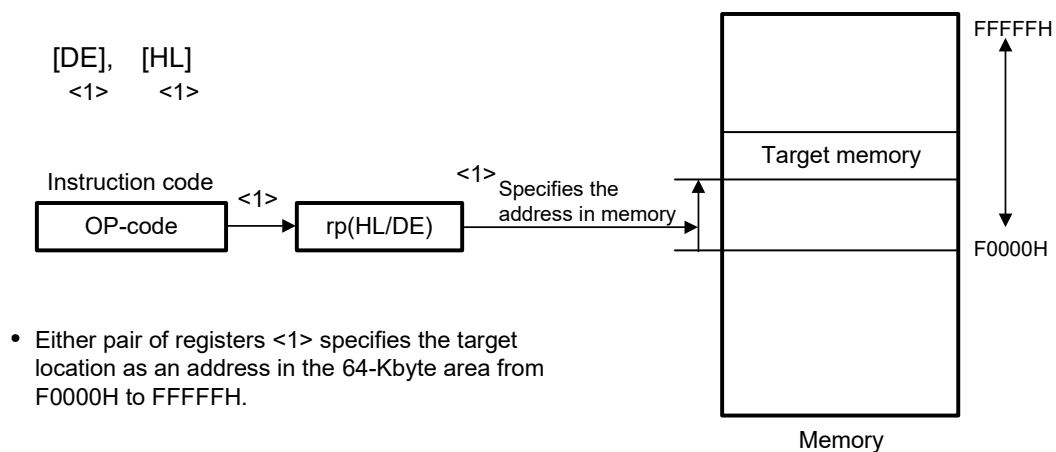
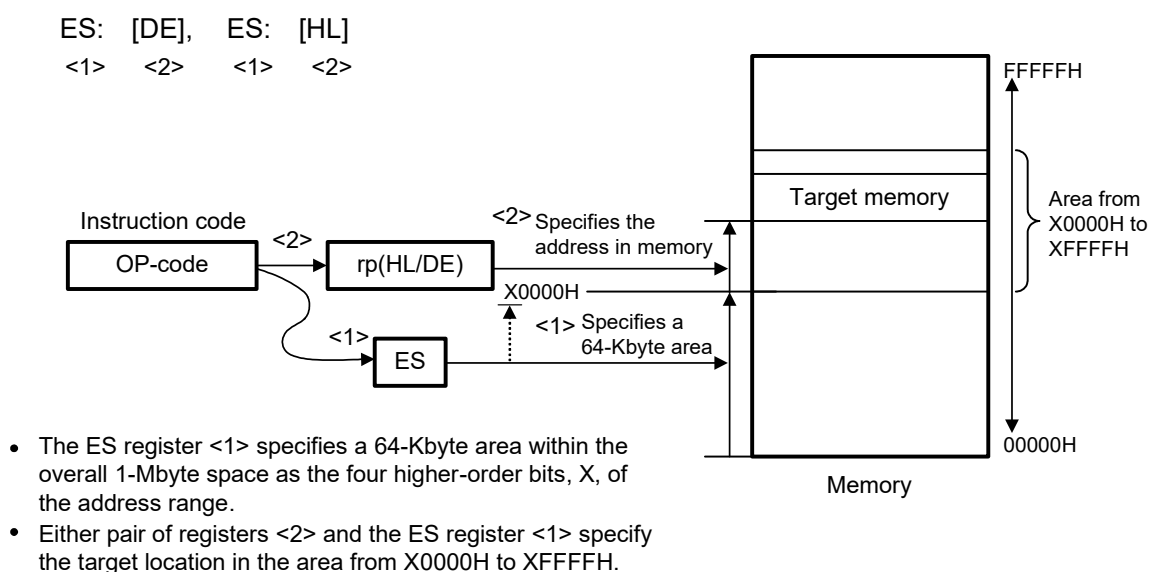

Figure 3-31. Example of ES:[DE], ES:[HL]



3.4.7 Based addressing

[Function]

Based addressing uses the contents of a register pair specified with the instruction word or 16-bit immediate data as a base address, and 8-bit immediate data or 16-bit immediate data as offset data. The sum of these values is used to specify the target address.

[Operand format]

Identifier	Description
–	[HL + byte], [DE + byte], [SP + byte] (only the space from F0000H to FFFFFH is specifiable)
–	word[B], word[C] (only the space from F0000H to FFFFFH is specifiable)
–	word[BC] (only the space from F0000H to FFFFFH is specifiable)
–	ES:[HL + byte], ES:[DE + byte] (higher 4-bit addresses are specified by the ES register)
–	ES:word[B], ES:word[C] (higher 4-bit addresses are specified by the ES register)
–	ES:word[BC] (higher 4-bit addresses are specified by the ES register)

Figure 3-32. Example of [SP+byte]

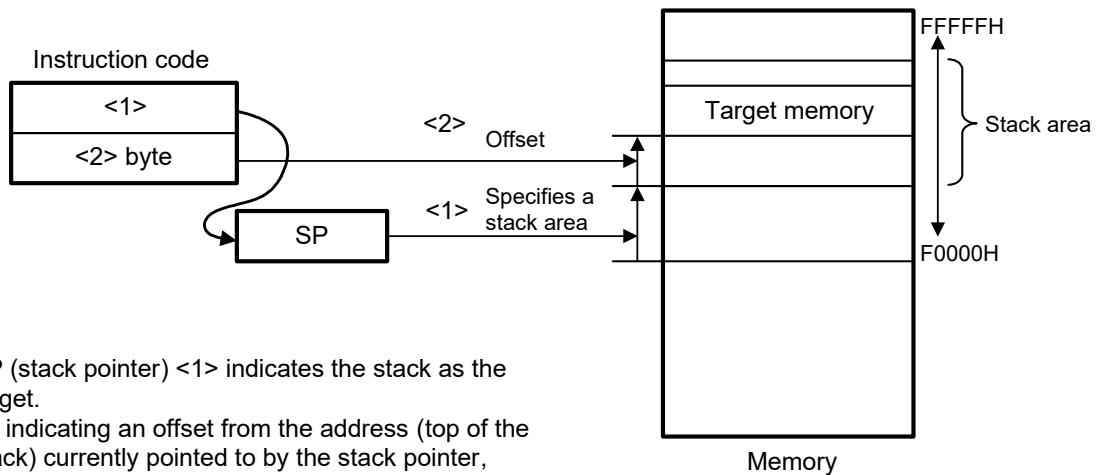

- SP (stack pointer) <1> indicates the stack as the target.
- By indicating an offset from the address (top of the stack) currently pointed to by the stack pointer, “byte” <2> indicates the target memory (SP + byte).

Figure 3-33. Example of [HL+byte], [DE+byte]

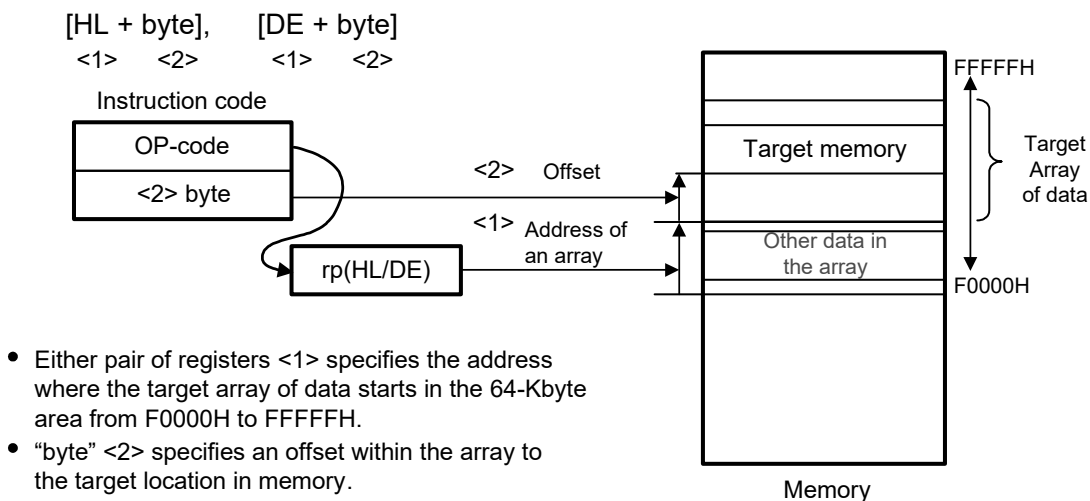

Figure 3-34. Example of word[B], word[C]

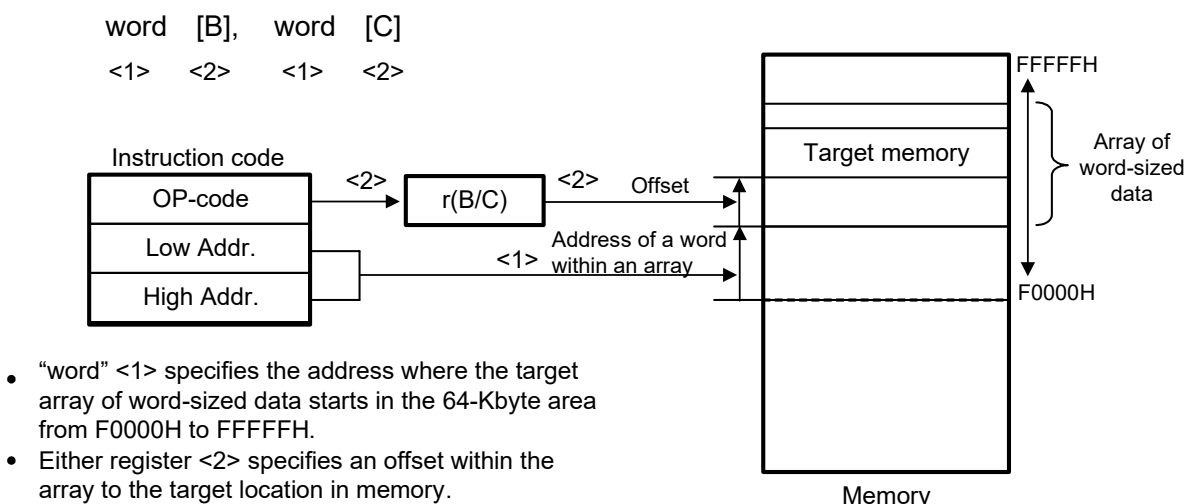

Figure 3-35. Example of word[BC]

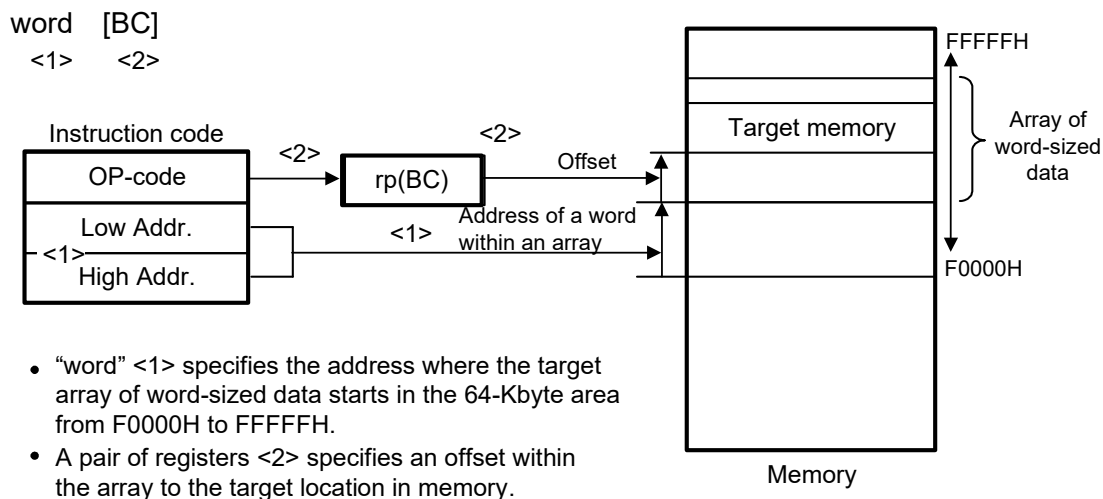

Figure 3-36. Example of ES:[HL+byte], ES:[DE+byte]

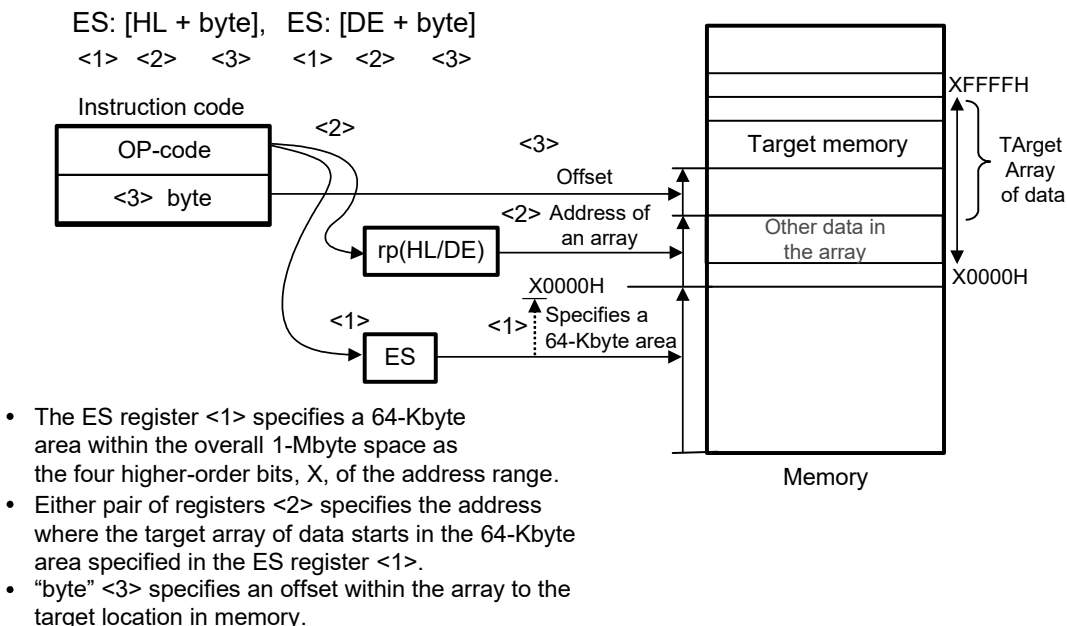

Figure 3-37. Example of ES:word[B], ES:word[C]

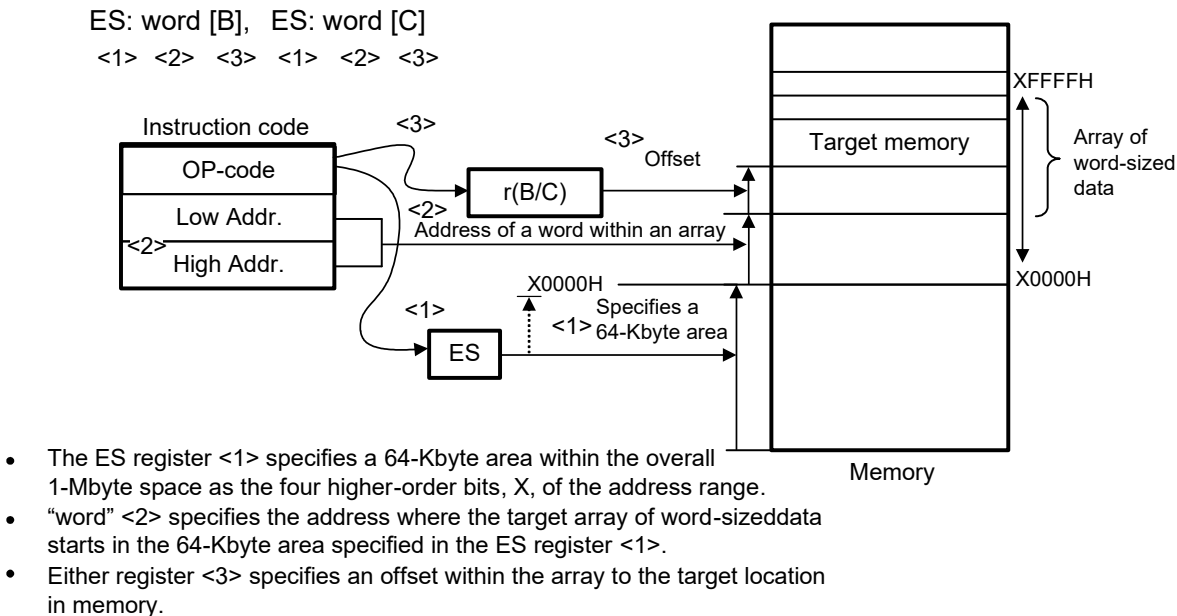
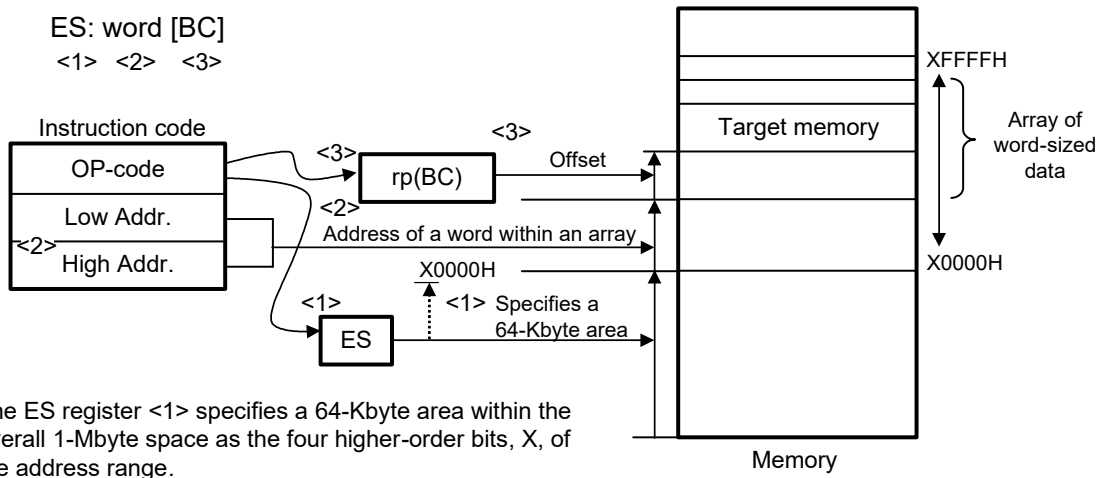

Figure 3-38. Example of ES:word[BC]



- The ES register <1> specifies a 64-Kbyte area within the overall 1-Mbyte space as the four higher-order bits, X, of the address range.
- “word” <2> specifies the address where the target array of word-sized data starts in the 64-Kbyte area specified in the ES register <1>.
- A pair of registers <3> specifies an offset within the array to the target location in memory.

3.4.8 Based indexed addressing

[Function]

Based indexed addressing uses the contents of a register pair specified with the instruction word as the base address, and the content of the B register or C register similarly specified with the instruction word as offset address. The sum of these values is used to specify the target address.

[Operand format]

Identifier	Description
-	[HL+B], [HL+C] (only the space from F0000H to FFFFFH is specifiable)
-	ES:[HL+B], ES:[HL+C] (higher 4-bit addresses are specified by the ES register)

Figure 3-39. Example of [HL+B], [HL+C]

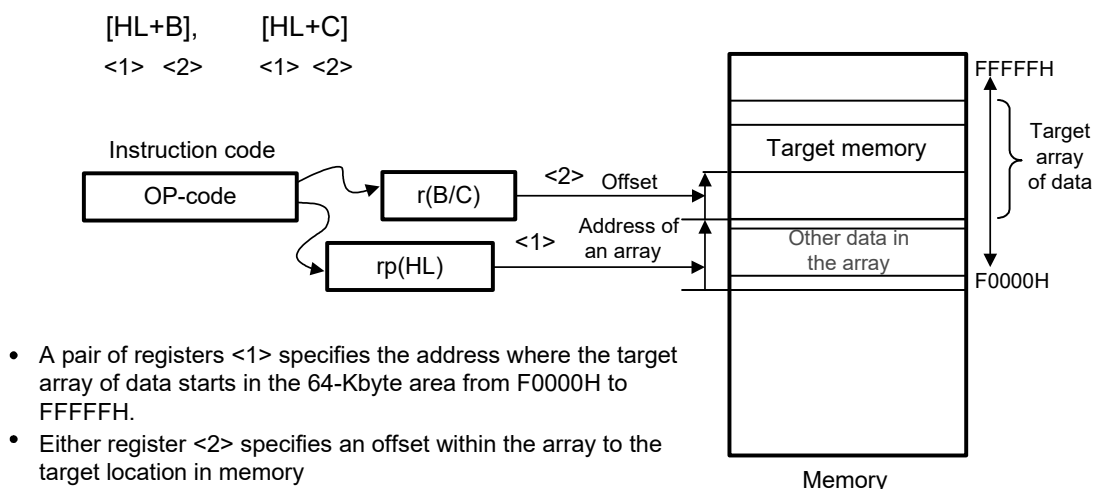
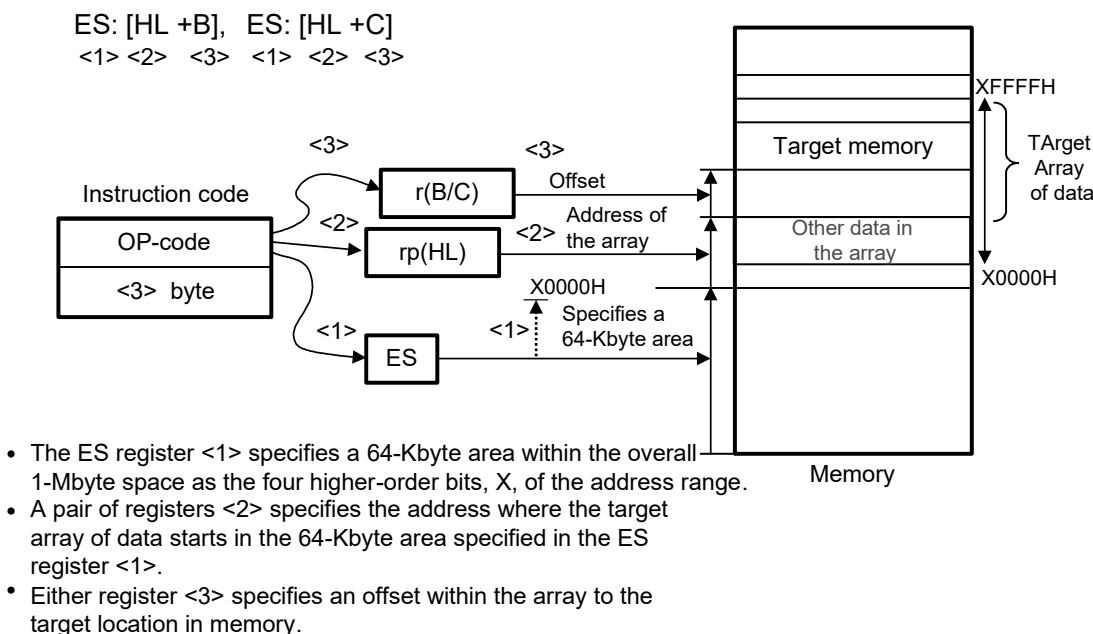

Figure 3-40. Example of ES:[HL+B], ES:[HL+C]



3.4.9 Stack addressing

[Function]

The stack area is indirectly addressed with the stack pointer (SP) values. This addressing is automatically employed when the PUSH, POP, subroutine call, and return instructions are executed or the register is saved/restored upon generation of an interrupt request.

Only the internal RAM area can be set as the stack area.

[Description format]

Identifier	Description
-	PUSH PSW AX/BC/DE/HL POP PSW AX/BC/DE/HL CALL/CALLT RET BRK RETB (Interrupt request generated) RETI

Each stack operation saves or restores data as shown in Figures 3-41 to 3-46.

Figure 3-41. Example of PUSH rp

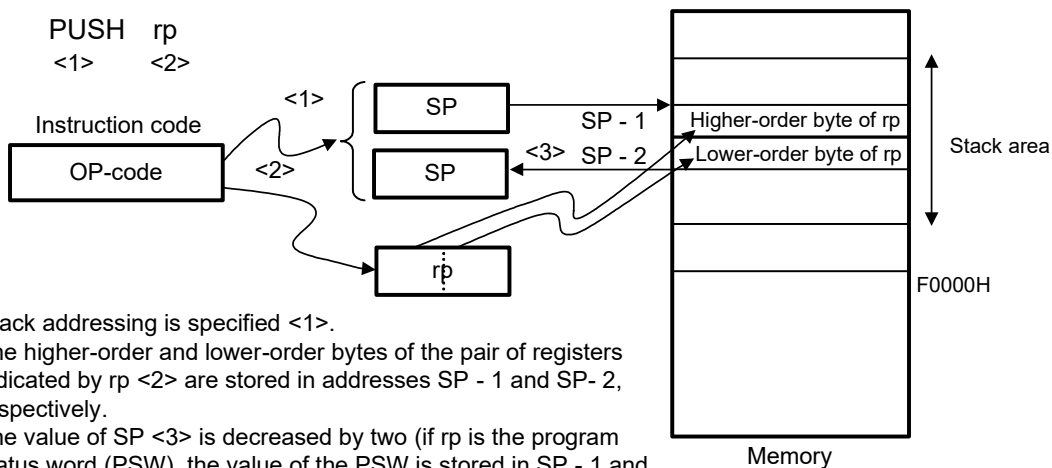

- Stack addressing is specified `<1>`.
- The higher-order and lower-order bytes of the pair of registers indicated by `rp <2>` are stored in addresses `SP - 1` and `SP - 2`, respectively.
- The value of `SP <3>` is decreased by two (if `rp` is the program status word (PSW), the value of the PSW is stored in `SP - 1` and 0 is stored in `SP - 2`).

Figure 3-42. Example of POP

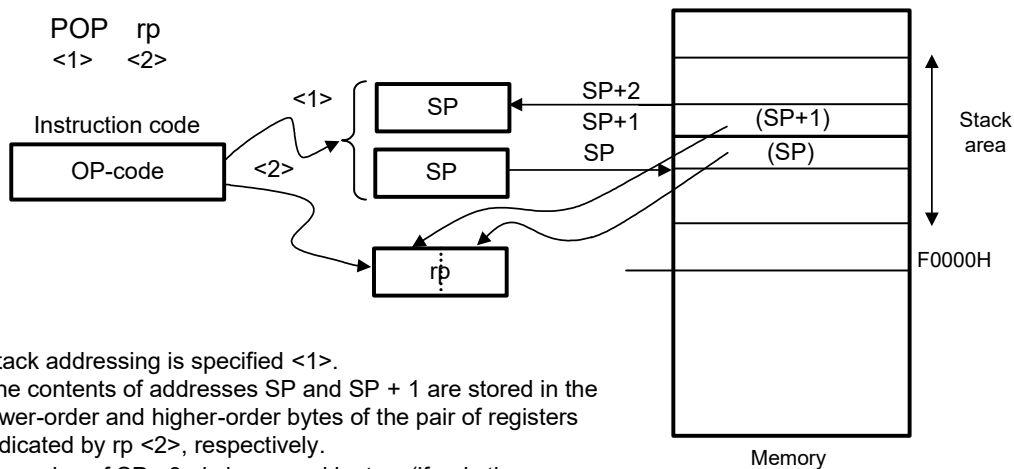

- Stack addressing is specified <1>.
- The contents of addresses SP and SP + 1 are stored in the lower-order and higher-order bytes of the pair of registers indicated by rp <2>, respectively.
- The value of SP <3> is increased by two (if rp is the program status word (PSW), the content of address SP + 1 is stored in the PSW).

Figure 3-43. Example of CALL, CALLT

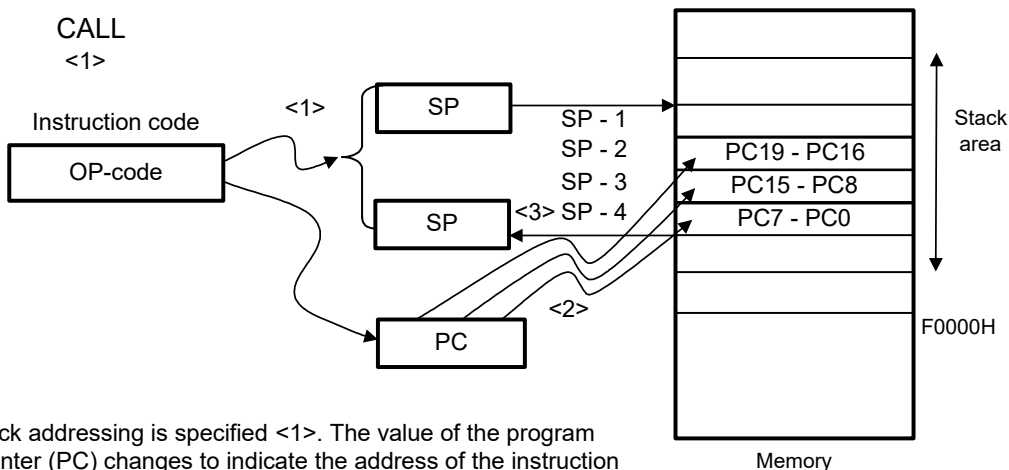

- Stack addressing is specified <1>. The value of the program counter (PC) changes to indicate the address of the instruction following the CALL instruction.
- The values of PC bits 19 to 16, 15 to 8, and 7 to 0 are stored in addresses SP - 2, SP - 3, and SP - 4, respectively <2>.
- The value of the SP <3> is decreased by 4.

Figure 3-44. Example of RET

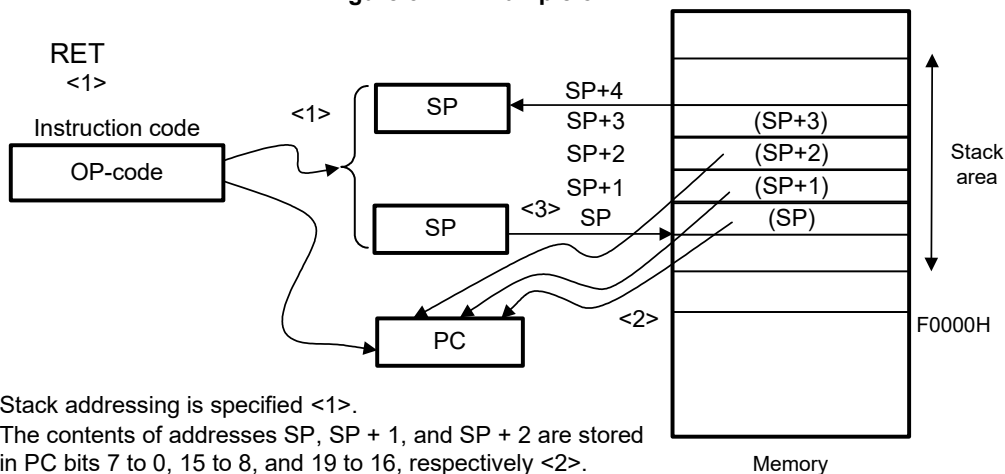

- Stack addressing is specified <1>.
- The contents of addresses SP, SP + 1, and SP + 2 are stored in PC bits 7 to 0, 15 to 8, and 19 to 16, respectively <2>.
- The value of SP <3> is increased by four.

Figure 3-45. Example of Interrupt, BRK

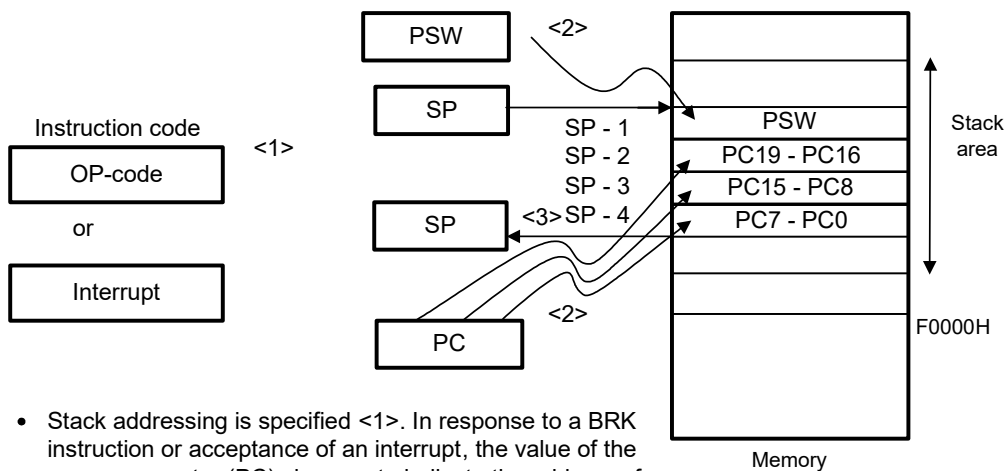

- Stack addressing is specified <1>. In response to a BRK instruction or acceptance of an interrupt, the value of the program counter (PC) changes to indicate the address of the next instruction.
- The values of the PSW, PC bits 19 to 16, 15 to 8, and 7 to 0 are stored in addresses SP - 1, SP - 2, SP - 3, and SP - 4, respectively <2>.
- The value of the SP <3> is decreased by 4.

Figure 3-46. Example of RETI, RETB

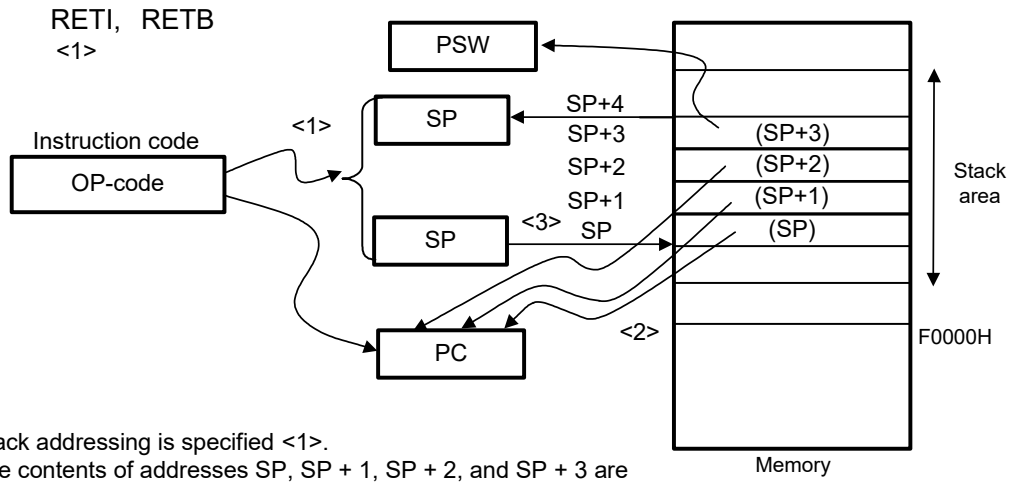

- Stack addressing is specified <1>.
- The contents of addresses SP, SP + 1, SP + 2, and SP + 3 are stored in PC bits 7 to 0, 15 to 8, 19 to 16, and the PSW, respectively <2>.
- The value of SP <3> is increased by four.

CHAPTER 4 PORT FUNCTIONS

4.1 Port Functions

The RL78/G13 microcontrollers are provided with digital I/O ports, which enable variety of control operations.

In addition to the function as digital I/O ports, these ports have several alternate functions. For details of the alternate functions, see **CHAPTER 2 PIN FUNCTIONS**.

4.2 Port Configuration

Ports include the following hardware.

Table 4-1. Port Configuration (1/2)

Item	Configuration
Control registers	Port mode registers (PM0 to PM12, PM14, PM15) Port registers (P0 to P15) Pull-up resistor option registers (PU0, PU1, PU3 to PU12, PU14) Port input mode registers (PIM0, PIM1, PIM4, PIM5, PIM8, PIM14) Port output mode registers (POM0, POM1, POM4, POM5, POM7 to POM9, POM14) Port mode control registers (PMC0, PMC3, PMC10 to PMC12, PMC14) A/D port configuration register (ADPC) Peripheral I/O redirection register (PIOR) Global digital input disable register (GDIDIS)
Port	<ul style="list-style-type: none"> ● 20-pin products Total: 16 (CMOS I/O: 13 (N-ch open drain I/O [V_{DD} tolerance]: 5), CMOS input: 3) ● 24-pin products Total: 20 (CMOS I/O: 15 (N-ch open drain I/O [V_{DD} tolerance]: 6), CMOS input: 3, N-ch open drain I/O [6-V tolerance]: 2) ● 25-pin products Total: 21 (CMOS I/O: 15 (N-ch open drain I/O [V_{DD} tolerance]: 6), CMOS input: 3, CMOS output: 1, N-ch open drain I/O [6-V tolerance]: 2) ● 30-pin products Total: 26 (CMOS I/O: 21 (N-ch open drain I/O [V_{DD} tolerance]: 9), CMOS input: 3, N-ch open drain I/O [6-V tolerance]: 2) ● 32-pin products Total: 28 (CMOS I/O: 22 (N-ch open drain I/O [V_{DD} tolerance]: 9), CMOS input: 3, N-ch open drain I/O [6-V tolerance]: 3) ● 36-pin products Total: 32 (CMOS I/O: 26 (N-ch open drain I/O [V_{DD} tolerance]: 10), CMOS input: 3, N-ch open drain I/O [6-V tolerance]: 3)

Table 4-1. Port Configuration (2/2)

Item	Configuration
Port	<ul style="list-style-type: none"> ● 40-pin products Total: 36 (CMOS I/O: 28 (N-ch open drain I/O [V_{DD} tolerance]: 10), CMOS input: 5, N-ch open drain I/O [6-V tolerance]: 3) ● 44-pin products Total: 40 (CMOS I/O: 31 (N-ch open drain I/O [V_{DD} tolerance]: 10), CMOS input: 5, N-ch open drain I/O [6-V tolerance]: 4) ● 48-pin products Total: 44 (CMOS I/O: 34 (N-ch open drain I/O [V_{DD} tolerance]: 11), CMOS input: 5, CMOS output: 1, N-ch open drain I/O [6-V tolerance]: 4) ● 52-pin products Total: 48 (CMOS I/O: 38 (N-ch open drain I/O [V_{DD} tolerance]: 13), CMOS input: 5, CMOS output: 1, N-ch open drain I/O [6-V tolerance]: 4) ● 64-pin products Total: 58 (CMOS I/O: 48 (N-ch open drain I/O [E_VDD tolerance]: 15), CMOS input: 5, CMOS output: 1, N-ch open drain I/O [6-V tolerance]: 4) ● 80-pin products Total: 74 (CMOS I/O: 64 (N-ch open drain I/O [E_VDD tolerance]: 21), CMOS input: 5, CMOS output: 1, N-ch open drain I/O [6-V tolerance]: 4) ● 100-pin products Total: 92 (CMOS I/O: 82 (N-ch open drain I/O [E_VDD tolerance]: 24), CMOS input: 5, CMOS output: 1, N-ch open drain I/O [6-V tolerance]: 4) ● 128-pin products Total: 120 (CMOS I/O: 110 (N-ch open drain I/O [E_VDD tolerance]: 25), CMOS input: 5, CMOS output: 1, N-ch open drain I/O [6-V tolerance]: 4)
Pull-up resistor	<ul style="list-style-type: none"> ● 20-pin products Total: 10 ● 24-pin products Total: 12 ● 25-pin products Total: 12 ● 30-pin products Total: 17 ● 32-pin products Total: 18 ● 36-pin products Total: 20 ● 40-pin products Total: 21 ● 44-pin products Total: 23 ● 48-pin products Total: 26 ● 52-pin products Total: 30 ● 64-pin products Total: 40 ● 80-pin products Total: 52 ● 100-pin products Total: 67 ● 128-pin products Total: 95

4.2.1 Port 0

Port 0 is an I/O port with an output latch. Port 0 can be set to the input mode or output mode in 1-bit units using port mode register 0 (PM0). When the P00 to P07 pins are used as an input port, use of an on-chip pull-up resistor can be specified in 1-bit units by pull-up resistor option register 0 (PU0).

Input to the P01, P03 and P04 pins can be specified through a normal input buffer or a TTL input buffer in 1-bit units using port input mode register 0 (PIM0).

Output from the P00 and P02 to P04 pins can be specified as N-ch open-drain output (V_{DD} tolerance ^{Note 1}/ E_{VDD} tolerance ^{Note 2}) in 1-bit units using port output mode register 0 (POM0).

To use P00 to P03 as digital input/output pins, set them in the digital I/O mode by using port mode control register 0 (PMC0) (can be specified in 1-bit units).

This port can also be used for timer I/O, A/D converter analog input, serial interface data I/O, and clock I/O.

When reset signal is generated, the following configuration will be set.

- P00 and P01 pins of the 20, 24, 25, 30, and 32-pin products ... Analog input
- P00, P01 and P04 to P07 pins of the other products ... Input mode
- P02 and P03 pins of the other products ... Analog input

- Notes 1.** For 20- to 52-pin products
2. For 64- to 128-pin products

4.2.2 Port 1

Port 1 is an I/O port with an output latch. Port 1 can be set to the input mode or output mode in 1-bit units using port mode register 1 (PM1). When the P10 to P17 pins are used as an input port, use of an on-chip pull-up resistor can be specified in 1-bit units by pull-up resistor option register 1 (PU1).

Input to the P10, P11, and P13 to P17 pins can be specified through a normal input buffer or a TTL input buffer in 1-bit units using port input mode register 1 (PIM1).

Output from the P10 to P15 and P17 pins can be specified as N-ch open-drain output (V_{DD} tolerance ^{Note 1}/ E_{VDD} tolerance ^{Note 2}) in 1-bit units using port output mode register 1 (POM1).

This port can also be used for serial interface data I/O, clock I/O, programming UART I/O, timer I/O, and external interrupt request input.

Reset signal generation sets port 1 to input mode.

- Notes 1.** For 20- to 52-pin products
2. For 64- to 128-pin products

4.2.3 Port 2

Port 2 is an I/O port with an output latch. Port 2 can be set to the input mode or output mode in 1-bit units using port mode register 2 (PM2).

This port can also be used for A/D converter analog input and reference voltage input (+ side and - side).

To use P20/ANI0 to P27/ANI7 as digital input/output pins, set them in the digital I/O mode by using the A/D port configuration register (ADPC). Use these pins starting from the upper bit.

To use P20/ANI0 to P27/ANI7 as analog input pins, set them in the analog input mode by using the A/D port configuration register (ADPC) and in the input mode by using the PM2 register. Use these pins starting from the lower bit.

Table 4-2. Setting Functions of P20/ANI0 to P27/ANI7 Pins

ADPC Register	PM2 Register	ADS Register	P20/ANI0 to P27/ANI7 Pins
Digital I/O selection	Input mode	–	Digital input
	Output mode	–	Digital output
Analog input selection	Input mode	Selects ANI.	Analog input (to be converted)
		Does not select ANI.	Analog input (not to be converted)
	Output mode	Selects ANI.	Setting prohibited
		Does not select ANI.	

All P20/ANI0 to P27/ANI7 are set in the analog input mode when the reset signal is generated.

4.2.4 Port 3

Port 3 is an I/O port with an output latch. Port 3 can be set to the input mode or output mode in 1-bit units using port mode register 3 (PM3). When the P30 to P37 pins are used as an input port, use of an on-chip pull-up resistor can be specified in 1-bit units by pull-up resistor option register 3 (PU3).

P35 to P37 pins can be specified as digital input/output or analog input in 1-bit units, using port mode control register 3 (PMC3).

This port can also be used for external interrupt request input, real-time clock correction clock output, clock/buzzer output, timer I/O, and A/D converter analog input.

Reset signal generation sets P30 to P34 to input mode, and sets P35 to P37 to analog input.

4.2.5 Port 4

Port 4 is an I/O port with an output latch. Port 4 can be set to the input mode or output mode in 1-bit units using port mode register 4 (PM4). When the P40 to P47 pins are used as an input port, use of an on-chip pull-up resistor can be specified in 1-bit units by pull-up resistor option register 4 (PU4).

Input to the P43 and P44 pins can be specified through a normal input buffer or a TTL input buffer in 1-bit units using port input mode register 4 (PIM4).

Output from the P43 to P45 pins can be specified as N-ch open-drain output (EV_{DD} tolerance) in 1-bit units using port output mode register 4 (POM4).

This port can also be used for data I/O for a flash memory programmer/debugger, timer I/O, serial interface data I/O, clock I/O, and external interrupt request input.

Reset signal generation sets port 4 to input mode.

4.2.6 Port 5

Port 5 is an I/O port with an output latch. Port 5 can be set to the input mode or output mode in 1-bit units using port mode register 5 (PM5). When the P50 to P57 pins are used as an input port, use of an on-chip pull-up resistor can be specified in 1-bit units by pull-up resistor option register 5 (PU5).

Input to the P53 to P55 pins can be specified through a normal input buffer or a TTL input buffer in 1-bit units using port input mode register 5 (PIM5).

Output from the P50 and P52 to P55 pins can be specified as N-ch open-drain output (V_{DD} tolerance ^{Note 1}/ EV_{DD} tolerance ^{Note 2}) in 1-bit units using port output mode register 5 (POM5).

This port can also be used for serial interface data I/O, clock I/O.

Reset signal generation sets port 5 to input mode.

- Notes 1.** For 24- to 52-pin products
2. For 64- to 128-pin products

4.2.7 Port 6

Port 6 is an I/O port with an output latch. Port 6 can be set to the input mode or output mode in 1-bit units using port mode register 6 (PM6). When the P64 to P67 pins are used as an input port, use of an on-chip pull-up resistor can be specified in 1-bit units by pull-up resistor option register 6 (PU6).

The output of the P60 to P63 pins is N-ch open-drain output (6-V tolerance).

This port can also be used for serial interface data I/O and clock I/O, and timer I/O.

Reset signal generation sets port 6 to input mode.

4.2.8 Port 7

Port 7 is an I/O port with an output latch. Port 7 can be set to the input mode or output mode in 1-bit units using port mode register 7 (PM7). When used as an input port, use of an on-chip pull-up resistor can be specified in 1-bit units by pull-up resistor option register 7 (PU7).

Output from the P71 and P74 pins can be specified as N-ch open-drain output (V_{DD} tolerance ^{Note 1}/ EV_{DD} tolerance ^{Note 2}) in 1-bit units using port output mode register 7 (POM7).

This port can also be used for key interrupt input, serial interface data I/O, clock I/O, and external interrupt request input.

Reset signal generation sets port 7 to input mode.

- Notes 1.** For 32- to 52-pin products
2. For 64- to 128-pin products

4.2.9 Port 8

Port 8 is an I/O port with an output latch. Port 8 can be set to the input mode or output mode in 1-bit units using port mode register 8 (PM8). When the P80 to P87 pins are used as an input port, use of an on-chip pull-up resistor can be specified in 1-bit units by pull-up resistor option register 8 (PU8).

Input to the P80 and P81 pins can be specified through a normal input buffer or a TTL input buffer in 1-bit units using port input mode register 8 (PIM8).

Output from the P80 to P82 pin can be specified as N-ch open-drain output (EV_{DD} tolerance) in 1-bit units using port output mode register 8 (POM8).

Reset signal generation sets port 8 to input mode.

4.2.10 Port 9

Port 9 is an I/O port with an output latch. Port 9 can be set to the input mode or output mode in 1-bit units using port mode register 9 (PM9). When used as an input port, use of an on-chip pull-up resistor can be specified in 1-bit units by pull-up resistor option register 9 (PU9).

Output from the P96 pin can be specified as N-ch open-drain output (EV_{DD} tolerance) in 1-bit units using port output mode register 9 (POM9).

This port can also be used for serial interface data I/O, clock I/O.

Reset signal generation sets port 9 to input mode.

4.2.11 Port 10

Port 10 is an I/O port with an output latch. Port 10 can be set to the input mode or output mode in 1-bit units using port mode register 10 (PM10). When the P100 to P106 pins are used as an input port, use of an on-chip pull-up resistor can be specified in 1-bit units by pull-up resistor option register 10 (PU10).

P100 pin can be specified as digital input/output or analog input in 1-bit units, using port mode control register 10 (PMC10).

This port can also be used for timer I/O and A/D converter analog input.

Reset signal generation sets P100 to analog input, P101 to P106 to input mode.

4.2.12 Port 11

Port 11 is an I/O port with an output latch. Port 11 can be set to the input mode or output mode in 1-bit units using port mode register 11 (PM11). When the P110 to P117 pins are used as an input port, use of an on-chip pull-up resistor can be specified in 1-bit units by pull-up resistor option register 11 (PU11).

Digital input/output or analog input can be specified for the P115 to P117 pins in 1-bit units, using port mode control register 11 (PMC11).

This port can also be used for A/D converter analog input as alternate function.

Reset signal generation sets P110 to P114 to input mode, and sets P115 to P117 to analog input.

4.2.13 Port 12

P120 and P125 to 127 are an I/O port with an output latch. Port 12 can be set to the input mode or output mode in 1-bit units using port mode register 12 (PM12). When used as an input port, use of an on-chip pull-up resistor can be specified by pull-up resistor option register 12 (PU12).

P121 to P124 are 4-bit input only ports.

Digital input/output or analog input can be specified for the P120 pin in 1-bit units, using port mode control register 12 (PMC12).

This port can also be used for A/D converter analog input, connecting resonator for main system clock, connecting resonator for subsystem clock, external clock input for main system clock, and external clock input for subsystem clock.

Reset signal generation sets P120 to analog input, and sets P121 to P127 to input mode.

4.2.14 Port 13

P130 is a 1-bit output-only port with an output latch.

P137 is a 1-bit input-only port.

P130 is fixed an output port, and P137 is fixed an input ports.

This port can also be used for external interrupt request input.

Remark When a reset takes effect, P130 outputs a low-level signal. If P130 is set to output a high-level signal before a reset takes effect, the output signal of P130 can be dummy-output as the CPU reset signal.

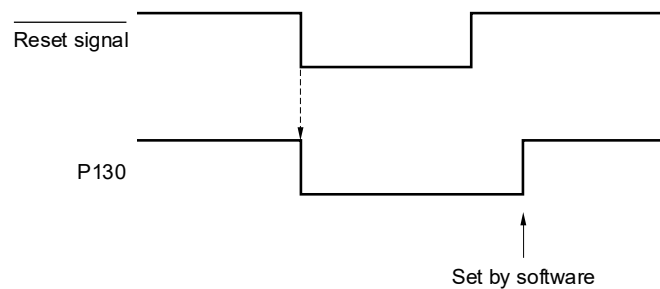

4.2.15 Port 14

Port 14 is an I/O port with an output latch. Port 14 can be set to the input mode or output mode in 1-bit units using port mode register 14 (PM14). When the P140 to P147 pins are used as an input port, use of an on-chip pull-up resistor can be specified in 1-bit units by pull-up resistor option register 14 (PU14).

Input to the P142 and P143 pins can be specified through a normal input buffer or a TTL input buffer in 1-bit units using port input mode register 14 (PIM14).

Output from the P142 to P144 pins can be specified as N-ch open-drain output (E_{VDD} tolerance) in 1-bit units using port output mode register 14 (POM14).

Digital input/output or analog input can be specified for the P147 pin in 1-bit units, using port mode control register 14 (PMC14).

This port can also be used for clock/buzzer output, external interrupt request input, and A/D converter analog input.

Reset signal generation sets P140 to P146 to input mode, and sets P147 to analog input, serial interface data I/O, clock I/O, and timer I/O.

4.2.16 Port 15

Port 15 is an I/O port with an output latch. Port 15 can be set to the input mode or output mode in 1-bit units using port mode register 15 (PM15).

This port can also be used for A/D converter analog input.

To use P150/ANI8 to P156/ANI4 as digital input pins, set them in the digital I/O mode by using the A/D port configuration register (ADPC) and in the input mode by using the PM15 register. Use these pins starting from the upper bit.

To use P150/ANI8 to P156/ANI4 as digital output pins, set them in the digital I/O mode by using the A/D port configuration register (ADPC) and in the output mode by using the PM15 register. Use these pins starting from the upper bit.

To use P150/ANI8 to P156/ANI4 as analog input pins, set them in the analog input mode by using the A/D port configuration register (ADPC) and in the input mode by using the PM15 register. Use these pins starting from the lower bit.

Table 4-3. Setting Functions of P150/ANI8 to P156/ANI14 Pins

ADPC Register	PM15 Register	ADS Register	P150/ANI8 to P156/ANI14 Pins
Digital I/O selection	Input mode	–	Digital input
	Output mode	–	Digital output
Analog input selection	Input mode	Selects ANI.	Analog input (to be converted)
		Does not select ANI.	Analog input (not to be converted)
	Output mode	Selects ANI.	Setting prohibited
		Does not select ANI.	

All P150/ANI8 to P156/ANI14 are set in the analog input mode when the reset signal is generated.

4.3 Registers Controlling Port Function

Port functions are controlled by the following registers.

- Port mode registers (PMxx)
- Port registers (Pxx)
- Pull-up resistor option registers (PUxx)
- Port input mode registers (PIMxx)
- Port output mode registers (POMxx)
- Port mode control registers (PMCxx)
- A/D port configuration register (ADPC)
- Peripheral I/O redirection register (PIOR)
- Global digital input disable register (GDIDIS)

Caution Which registers and bits are included depends on the product. For registers and bits mounted on each product, see Tables 4-4 and 4-5. Be sure to set bits that are not mounted to their initial values.

Table 4-4. PMxx, Pxx, PUxx, PIMxx, POMxx, PMCxx registers and the bits mounted on each product (20-pin products to 64-pin products) (1/3)

Port		Bit name						64 pin	52 pin	48 pin	44 pin	40 pin	36 pin	32 pin	30 pin	25 pin	24 pin	20 pin
		PMxx register	Pxx register	PUxx register	PIMxx register	POMxx register	PMCxx register											
Port 0	0	PM00	P00	PU00	–	POM00	PMC00 ^{Note}	√	√	√	√	√	√	√	√	√	√	√
	1	PM01	P01	PU01	PIM01	–	PMC01 ^{Note}	√	√	√	√	√	√	√	√	√	√	√
	2	PM02	P02	PU02	–	POM02	PMC02	√	√	–	–	–	–	–	–	–	–	–
	3	PM03	P03	PU03	PIM03	POM03	PMC03	√	√	–	–	–	–	–	–	–	–	–
	4	PM04	P04	PU04	PIM04	POM04	–	√	–	–	–	–	–	–	–	–	–	–
	5	PM05	P05	PU05	–	–	–	√	–	–	–	–	–	–	–	–	–	–
	6	PM06	P06	PU06	–	–	–	√	–	–	–	–	–	–	–	–	–	–
	7	–	–	–	–	–	–	–	–	–	–	–	–	–	–	–	–	–
Port 1	0	PM10	P10	PU10	PIM10	POM10	–	√	√	√	√	√	√	√	√	√	√	√
	1	PM11	P11	PU11	PIM11	POM11	–	√	√	√	√	√	√	√	√	√	√	√
	2	PM12	P12	PU12	–	POM12	–	√	√	√	√	√	√	√	√	√	√	√
	3	PM13	P13	PU13	PIM13	POM13	–	√	√	√	√	√	√	√	√	–	–	–
	4	PM14	P14	PU14	PIM14	POM14	–	√	√	√	√	√	√	√	√	–	–	–
	5	PM15	P15	PU15	PIM15	POM15	–	√	√	√	√	√	√	√	√	–	–	–
	6	PM16	P16	PU16	PIM16	–	–	√	√	√	√	√	√	√	√	√	√	√
	7	PM17	P17	PU17	PIM17	POM17	–	√	√	√	√	√	√	√	√	√	√	√
Port 2	0	PM20	P20	–	–	–	–	√	√	√	√	√	√	√	√	√	√	√
	1	PM21	P21	–	–	–	–	√	√	√	√	√	√	√	√	√	√	√
	2	PM22	P22	–	–	–	–	√	√	√	√	√	√	√	√	√	√	√
	3	PM23	P23	–	–	–	–	√	√	√	√	√	√	√	√	–	–	–
	4	PM24	P24	–	–	–	–	√	√	√	√	√	√	–	–	–	–	–
	5	PM25	P25	–	–	–	–	√	√	√	√	√	√	–	–	–	–	–
	6	PM26	P26	–	–	–	–	√	√	√	√	√	–	–	–	–	–	–
	7	PM27	P27	–	–	–	–	√	√	√	√	–	–	–	–	–	–	–

Note 20-pin, 24-pin, 25-pin, 30-pin, and 32-pin products only.

Table 4-4. PMxx, Pxx, PUxx, PIMxx, POMxx, PMCxx registers and the bits mounted on each product (20-pin products to 64-pin products) (2/3)

Port		Bit name						64 pin	52 pin	48 pin	44 pin	40 pin	36 pin	32 pin	30 pin	25 pin	24 pin	20 pin
		PMxx register	Pxx register	PUxx register	PIMxx register	POMxx register	PMCxx register											
Port 3	0	PM30	P30	PU30	-	-	-	√	√	√	√	√	√	√	√	√	√	√
	1	PM31	P31	PU31	-	-	-	√	√	√	√	√	√	√	√	√	√	-
	2	-	-	-	-	-	-	-	-	-	-	-	-	-	-	-	-	-
	3	-	-	-	-	-	-	-	-	-	-	-	-	-	-	-	-	-
	4	-	-	-	-	-	-	-	-	-	-	-	-	-	-	-	-	-
	5	-	-	-	-	-	-	-	-	-	-	-	-	-	-	-	-	-
	6	-	-	-	-	-	-	-	-	-	-	-	-	-	-	-	-	-
	7	-	-	-	-	-	-	-	-	-	-	-	-	-	-	-	-	-
Port 4	0	PM40	P40	PU40	-	-	-	√	√	√	√	√	√	√	√	√	√	√
	1	PM41	P41	PU41	-	-	-	√	√	√	√	-	-	-	-	-	-	-
	2	PM42	P42	PU42	-	-	-	√	-	-	-	-	-	-	-	-	-	-
	3	PM43	P43	PU43	-	-	-	√	-	-	-	-	-	-	-	-	-	-
	4	-	-	-	-	-	-	-	-	-	-	-	-	-	-	-	-	-
	5	-	-	-	-	-	-	-	-	-	-	-	-	-	-	-	-	-
	6	-	-	-	-	-	-	-	-	-	-	-	-	-	-	-	-	-
	7	-	-	-	-	-	-	-	-	-	-	-	-	-	-	-	-	-
Port 5	0	PM50	P50	PU50	-	POM50	-	√	√	√	√	√	√	√	√	√	√	-
	1	PM51	P51	PU51	-	-	-	√	√	-	√	√	√	√	√	-	-	-
	2	PM52	P52	PU52	-	-	-	√	-	-	-	-	-	-	-	-	-	-
	3	PM53	P53	PU53	-	-	-	√	-	-	-	-	-	-	-	-	-	-
	4	PM54	P54	PU54	-	-	-	√	-	-	-	-	-	-	-	-	-	-
	5	PM55	P55	PU55	PIM55	POM55	-	√	-	-	-	-	-	-	-	-	-	-
	6	-	-	-	-	-	-	-	-	-	-	-	-	-	-	-	-	-
	7	-	-	-	-	-	-	-	-	-	-	-	-	-	-	-	-	-
Port 6	0	PM60	P60	-	-	-	-	√	√	√	√	√	√	√	√	√	√	-
	1	PM61	P61	-	-	-	-	√	√	√	√	√	√	√	√	√	√	-
	2	PM62	P62	-	-	-	-	√	√	√	√	√	√	√	-	-	-	-
	3	PM63	P63	-	-	-	-	√	√	√	√	-	-	-	-	-	-	-
	4	-	-	-	-	-	-	-	-	-	-	-	-	-	-	-	-	-
	5	-	-	-	-	-	-	-	-	-	-	-	-	-	-	-	-	-
	6	-	-	-	-	-	-	-	-	-	-	-	-	-	-	-	-	-
	7	-	-	-	-	-	-	-	-	-	-	-	-	-	-	-	-	-
Port 7	0	PM70	P70	PU70	-	-	-	√	√	√	√	√	√	√	-	-	-	-
	1	PM71	P71	PU71	-	POM71	-	√	√	√	√	√	√	-	-	-	-	-
	2	PM72	P72	PU72	-	-	-	√	√	√	√	√	√	-	-	-	-	-
	3	PM73	P73	PU73	-	-	-	√	√	√	√	√	-	-	-	-	-	-
	4	PM74	P74	PU74	-	POM74	-	√	√	√	-	-	-	-	-	-	-	-
	5	PM75	P75	PU75	-	-	-	√	√	√	-	-	-	-	-	-	-	-
	6	PM76	P76	PU76	-	-	-	√	√	-	-	-	-	-	-	-	-	-
	7	PM77	P77	PU77	-	-	-	√	√	-	-	-	-	-	-	-	-	-

Table 4-4. PMxx, Pxx, PUxx, PIMxx, POMxx, PMCxx registers and the bits mounted on each product (20-pin products to 64-pin products) (3/3)

Port	Bit name						64 pin	52 pin	48 pin	44 pin	40 pin	36 pin	32 pin	30 pin	25 pin	24 pin	20 pin
	PMxx register	Pxx register	PUxx register	PIMxx register	POMxx register	PMCxx register											
Port 8	-	-	-	-	-	-	-	-	-	-	-	-	-	-	-	-	-
Port 9	-	-	-	-	-	-	-	-	-	-	-	-	-	-	-	-	-
Port 10	-	-	-	-	-	-	-	-	-	-	-	-	-	-	-	-	-
Port 11	-	-	-	-	-	-	-	-	-	-	-	-	-	-	-	-	-
Port 12	0	PM120	P120	PU120	-	-	PMC120	√	√	√	√	√	√	√	√	-	-
	1	-	P121	-	-	-	-	√	√	√	√	√	√	√	√	√	√
	2	-	P122	-	-	-	-	√	√	√	√	√	√	√	√	√	√
	3	-	P123	-	-	-	-	√	√	√	√	√	-	-	-	-	-
	4	-	P124	-	-	-	-	√	√	√	√	√	-	-	-	-	-
	5	-	-	-	-	-	-	-	-	-	-	-	-	-	-	-	-
	6	-	-	-	-	-	-	-	-	-	-	-	-	-	-	-	-
Port 13	0	-	P130	-	-	-	-	√	√	√	-	-	-	-	-	√	-
	1	-	-	-	-	-	-	-	-	-	-	-	-	-	-	-	-
	2	-	-	-	-	-	-	-	-	-	-	-	-	-	-	-	-
	3	-	-	-	-	-	-	-	-	-	-	-	-	-	-	-	-
	4	-	-	-	-	-	-	-	-	-	-	-	-	-	-	-	-
	5	-	-	-	-	-	-	-	-	-	-	-	-	-	-	-	-
	6	-	-	-	-	-	-	-	-	-	-	-	-	-	-	-	-
7	-	P137	-	-	-	-	-	√	√	√	√	√	√	√	√	√	√
Port 14	0	PM140	P140	PU140	-	-	-	√	√	√	-	-	-	-	-	-	-
	1	PM141	P141	PU141	-	-	-	√	-	-	-	-	-	-	-	-	-
	2	-	-	-	-	-	-	-	-	-	-	-	-	-	-	-	-
	3	-	-	-	-	-	-	-	-	-	-	-	-	-	-	-	-
	4	-	-	-	-	-	-	-	-	-	-	-	-	-	-	-	-
	5	-	-	-	-	-	-	-	-	-	-	-	-	-	-	-	-
	6	PM146	P146	PU146	-	-	-	√	√	√	√	-	-	-	-	-	-
7	PM147	P147	PU147	-	-	PMC147	√	√	√	√	√	√	√	√	√	√	
Port 15	-	-	-	-	-	-	-	-	-	-	-	-	-	-	-	-	

Table 4-5. PMxx, Pxx, PUxx, PIMxx, POMxx, PMCxx registers and the bits mounted on each product (80-pin products to 128-pin products) (1/4)

Port		Bit name						128 pin	100 pin	80 pin
		PMxx register	Pxx register	PUxx register	PIMxx register	POMxx register	PMCxx register			
Port 0	0	PM00	P00	PU00	–	POM00	–	√	√	√
	1	PM01	P01	PU01	PIM01	–	–	√	√	√
	2	PM02	P02	PU02	–	POM02	PMC02	√	√	√
	3	PM03	P03	PU03	PIM03	POM03	PMC03	√	√	√
	4	PM04	P04	PU04	PIM04	POM04	–	√	√	√
	5	PM05	P05	PU05	–	–	–	√	√	√
	6	PM06	P06	PU06	–	–	–	√	√	√
	7	PM07	P07	PU07	–	–	–	√	–	–
Port 1	0	PM10	P10	PU10	PIM10	POM10	–	√	√	√
	1	PM11	P11	PU11	PIM11	POM11	–	√	√	√
	2	PM12	P12	PU12	–	POM12	–	√	√	√
	3	PM13	P13	PU13	PIM13	POM13	–	√	√	√
	4	PM14	P14	PU14	PIM14	POM14	–	√	√	√
	5	PM15	P15	PU15	PIM15	POM15	–	√	√	√
	6	PM16	P16	PU16	PIM16	–	–	√	√	√
	7	PM17	P17	PU17	PIM17	POM17	–	√	√	√
Port 2	0	PM20	P20	–	–	–	–	√	√	√
	1	PM21	P21	–	–	–	–	√	√	√
	2	PM22	P22	–	–	–	–	√	√	√
	3	PM23	P23	–	–	–	–	√	√	√
	4	PM24	P24	–	–	–	–	√	√	√
	5	PM25	P25	–	–	–	–	√	√	√
	6	PM26	P26	–	–	–	–	√	√	√
	7	PM27	P27	–	–	–	–	√	√	√
Port 3	0	PM30	P30	PU30	–	–	–	√	√	√
	1	PM31	P31	PU31	–	–	–	√	√	√
	2	PM32	P32	PU32	–	–	–	√	–	–
	3	PM33	P33	PU33	–	–	–	√	–	–
	4	PM34	P34	PU34	–	–	–	√	–	–
	5	PM35	P35	PU35	–	–	PMC35	√	–	–
	6	PM36	P36	PU36	–	–	PMC36	√	–	–
	7	PM37	P37	PU37	–	–	PMC37	√	–	–

Table 4-5. PMxx, Pxx, PUxx, PIMxx, POMxx, PMCxx registers and the bits mounted on each product (80-pin products to 128-pin products) (2/4)

Port		Bit name						128 pin	100 pin	80 pin
		PMxx register	Pxx register	PUxx register	PIMxx register	POMxx register	PMCxx register			
Port 4	0	PM40	P40	PU40	–	–	–	√	√	√
	1	PM41	P41	PU41	–	–	–	√	√	√
	2	PM42	P42	PU42	–	–	–	√	√	√
	3	PM43	P43	PU43	PIM43	POM43	–	√	√	√
	4	PM44	P44	PU44	PIM44	POM44	–	√	√	√
	5	PM45	P45	PU45	–	POM45	–	√	√	√
	6	PM46	P46	PU46	–	–	–	√	√	–
	7	PM47	P47	PU47	–	–	–	√	√	–
Port 5	0	PM50	P50	PU50	–	POM50	–	√	√	√
	1	PM51	P51	PU51	–	–	–	√	√	√
	2	PM52	P52	PU52	–	POM52	–	√	√	√
	3	PM53	P53	PU53	PIM53	POM53	–	√	√	√
	4	PM54	P54	PU54	PIM54	POM54	–	√	√	√
	5	PM55	P55	PU55	PIM55	POM55	–	√	√	√
	6	PM56	P56	PU56	–	–	–	√	√	–
	7	PM57	P57	PU57	–	–	–	√	√	–
Port 6	0	PM60	P60	–	–	–	–	√	√	√
	1	PM61	P61	–	–	–	–	√	√	√
	2	PM62	P62	–	–	–	–	√	√	√
	3	PM63	P63	–	–	–	–	√	√	√
	4	PM64	P64	PU64	–	–	–	√	√	√
	5	PM65	P65	PU65	–	–	–	√	√	√
	6	PM66	P66	PU66	–	–	–	√	√	√
	7	PM67	P67	PU67	–	–	–	√	√	√
Port 7	0	PM70	P70	PU70	–	–	–	√	√	√
	1	PM71	P71	PU71	–	POM71	–	√	√	√
	2	PM72	P72	PU72	–	–	–	√	√	√
	3	PM73	P73	PU73	–	–	–	√	√	√
	4	PM74	P74	PU74	–	POM74	–	√	√	√
	5	PM75	P75	PU75	–	–	–	√	√	√
	6	PM76	P76	PU76	–	–	–	√	√	√
	7	PM77	P77	PU77	–	–	–	√	√	√
Port 8	0	PM80	P80	PU80	PIM80	POM80	–	√	√	–
	1	PM81	P81	PU81	PIM81	POM81	–	√	√	–
	2	PM82	P82	PU82	–	POM82	–	√	√	–
	3	PM83	P83	PU83	–	–	–	√	√	–
	4	PM84	P84	PU84	–	–	–	√	√	–
	5	PM85	P85	PU85	–	–	–	√	√	–
	6	PM86	P86	PU86	–	–	–	√	√	–
	7	PM87	P87	PU87	–	–	–	√	√	–

Table 4-5. PMxx, Pxx, PUxx, PIMxx, POMxx, PMCxx registers and the bits mounted on each product (80-pin products to 128-pin products) (3/4)

Port		Bit name						128 pin	100 pin	80 pin
		PMxx register	Pxx register	PUxx register	PIMxx register	POMxx register	PMCxx register			
Port 9	0	PM90	P90	PU90	–	–	–	√	–	–
	1	PM91	P91	PU91	–	–	–	√	–	–
	2	PM92	P92	PU92	–	–	–	√	–	–
	3	PM93	P93	PU93	–	–	–	√	–	–
	4	PM94	P94	PU94	–	–	–	√	–	–
	5	PM95	P95	PU95	–	–	–	√	–	–
	6	PM96	P96	PU96	–	POM96	–	√	–	–
Port 10	0	PM100	P100	PU100	–	–	PMC100	√	√	√
	1	PM101	P101	PU101	–	–	–	√	√	–
	2	PM102	P102	PU102	–	–	–	√	√	–
	3	PM103	P103	PU103	–	–	–	√	–	–
	4	PM104	P104	PU104	–	–	–	√	–	–
	5	PM105	P105	PU105	–	–	–	√	–	–
	6	PM106	P106	PU106	–	–	–	√	–	–
Port 11	0	PM110	P110	PU110	–	–	–	√	√	√
	1	PM111	P111	PU111	–	–	–	√	√	√
	2	PM112	P112	PU112	–	–	–	√	–	–
	3	PM113	P113	PU113	–	–	–	√	–	–
	4	PM114	P114	PU114	–	–	–	√	–	–
	5	PM115	P115	PU115	–	–	PMC115	√	–	–
	6	PM116	P116	PU116	–	–	PMC116	√	–	–
Port 12	0	PM120	P120	PU120	–	–	PMC120	√	√	√
	1	–	P121	–	–	–	–	√	√	√
	2	–	P122	–	–	–	–	√	√	√
	3	–	P123	–	–	–	–	√	√	√
	4	–	P124	–	–	–	–	√	√	√
	5	PM125	P125	PU125	–	–	–	√	–	–
	6	PM126	P126	PU126	–	–	–	√	–	–
Port 13	0	–	P130	–	–	–	–	√	√	√
	1	–	–	–	–	–	–	–	–	–
	2	–	–	–	–	–	–	–	–	–
	3	–	–	–	–	–	–	–	–	–
	4	–	–	–	–	–	–	–	–	–
	5	–	–	–	–	–	–	–	–	–
	6	–	–	–	–	–	–	–	–	–
7	–	P137	–	–	–	–	√	√	√	

Table 4-5. PMxx, Pxx, PUxx, PIMxx, POMxx, PMCxx registers and the bits mounted on each product (80-pin products to 128-pin products) (4/4)

Port		Bit name						128 pin	100 pin	80 pin
		PMxx register	Pxx register	PUxx register	PIMxx register	POMxx register	PMCxx register			
Port 14	0	PM140	P140	PU140	–	–	–	√	√	√
	1	PM141	P141	PU141	–	–	–	√	√	√
	2	PM142	P142	PU142	PIM142	POM142	–	√	√	√
	3	PM143	P143	PU143	PIM143	POM143	–	√	√	√
	4	PM144	P144	PU144	–	POM144	–	√	√	√
	5	PM145	P145	PU145	–	–	–	√	√	–
	6	PM146	P146	PU146	–	–	–	√	√	√
	7	PM147	P147	PU147	–	–	PMC147	√	√	√
Port 15	0	PM150	P150	–	–	–	–	√	√	√
	1	PM151	P151	–	–	–	–	√	√	√
	2	PM152	P152	–	–	–	–	√	√	√
	3	PM153	P153	–	–	–	–	√	√	√
	4	PM154	P154	–	–	–	–	√	√	–
	5	PM155	P155	–	–	–	–	√	√	–
	6	PM156	P156	–	–	–	–	√	√	–
	7	–	–	–	–	–	–	–	–	–

4.3.1 Port mode registers (PMxx)

These registers specify input or output mode for the port in 1-bit units.

These registers can be set by a 1-bit or 8-bit memory manipulation instruction.

Reset signal generation sets these registers to FFH.

When port pins are used as alternate-function pins, set the port mode register by referencing **4.5 Register Settings When Using Alternate Function**.

Figure 4-1. Format of Port Mode Register

Symbol	7	6	5	4	3	2	1	0	Address	After reset	R/W
PM0	PM07	PM06	PM05	PM04	PM03	PM02	PM01	PM00	FFF20H	FFH	R/W
PM1	PM17	PM16	PM15	PM14	PM13	PM12	PM11	PM10	FFF21H	FFH	R/W
PM2	PM27	PM26	PM25	PM24	PM23	PM22	PM21	PM20	FFF22H	FFH	R/W
PM3	PM37	PM36	PM35	PM34	PM33	PM32	PM31	PM30	FFF23H	FFH	R/W
PM4	PM47	PM46	PM45	PM44	PM43	PM42	PM41	PM40	FFF24H	FFH	R/W
PM5	PM57	PM56	PM55	PM54	PM53	PM52	PM51	PM50	FFF25H	FFH	R/W
PM6	PM67	PM66	PM65	PM64	PM63	PM62	PM61	PM60	FFF26H	FFH	R/W
PM7	PM77	PM76	PM75	PM74	PM73	PM72	PM71	PM70	FFF27H	FFH	R/W
PM8	PM87	PM86	PM85	PM84	PM83	PM82	PM81	PM80	FFF28H	FFH	R/W
PM9	PM97	PM96	PM95	PM94	PM93	PM92	PM91	PM90	FFF29H	FFH	R/W
PM10	1	PM106	PM105	PM104	PM103	PM102	PM101	PM100	FFF2AH	FFH	R/W
PM11	PM117	PM116	PM115	PM114	PM113	PM112	PM111	PM110	FFF2BH	FFH	R/W
PM12	PM127	PM126	PM125	1	1	1	1	PM120	FFF2CH	FFH	R/W
PM14	PM147	PM146	PM145	PM144	PM143	PM142	PM141	PM140	FFF2EH	FFH	R/W
PM15	1	PM156	PM155	PM154	PM153	PM152	PM151	PM150	FFF2FH	FFH	R/W

PMmn	<p>PMn pin I/O mode selection (m = 0 to 12, 14, 15; n = 0 to 7)</p>
0	Output mode (output buffer on)
1	Input mode (output buffer off)

Caution Be sure to set bits that are not mounted to their initial values.

4.3.2 Port registers (Pxx)

These registers set the output latch value of a port.

If the data is read in the input mode, the pin level is read. If it is read in the output mode, the output latch value is read^{Note}.

These registers can be set by a 1-bit or 8-bit memory manipulation instruction.

Reset signal generation clears these registers to 00H.

Note If P02, P03, P20 to P27, P35 to P37, P100, P115 to P117, P120, P147, and P150 to P156 are set up as analog inputs of the A/D converter, when a port is read while in the input mode, 0 is always returned, not the pin level.

Figure 4-2. Format of Port Register

Symbol	7	6	5	4	3	2	1	0	Address	After reset	R/W
P0	P07	P06	P05	P04	P03	P02	P01	P00	FFF00H	00H (output latch)	R/W
P1	P17	P16	P15	P14	P13	P12	P11	P10	FFF01H	00H (output latch)	R/W
P2	P27	P26	P25	P24	P23	P22	P21	P20	FFF02H	00H (output latch)	R/W
P3	P37	P36	P35	P34	P33	P32	P31	P30	FFF03H	00H (output latch)	R/W
P4	P47	P46	P45	P44	P43	P42	P41	P40	FFF04H	00H (output latch)	R/W
P5	P57	P56	P55	P54	P53	P52	P51	P50	FFF05H	00H (output latch)	R/W
P6	P67	P66	P65	P64	P63	P62	P61	P60	FFF06H	00H (output latch)	R/W
P7	P77	P76	P75	P74	P73	P72	P71	P70	FFF07H	00H (output latch)	R/W
P8	P87	P86	P85	P84	P83	P82	P81	P80	FFF08H	00H (output latch)	R/W
P9	P97	P96	P95	P94	P93	P92	P91	P90	FFF09H	00H (output latch)	R/W
P10	0	P106	P105	P104	P103	P102	P101	P100	FFF0AH	00H (output latch)	R/W
P11	P117	P116	P115	P114	P113	P112	P111	P110	FFF0BH	00H (output latch)	R/W
P12	P127	P126	P125	P124	P123	P122	P121	P120	FFF0CH	Undefined	R/W ^{Note 1}
P13	P137	0	0	0	0	0	0	P130	FFF0DH	Note 2	R/W ^{Note 1}
P14	P147	P146	P145	P144	P143	P142	P141	P140	FFF0EH	00H (output latch)	R/W
P15	0	P156	P155	P154	P153	P152	P151	P150	FFF0FH	00H (output latch)	R/W

Pmn	Output data control (in output mode)	Input data read (in input mode)
0	Output 0	Input low level
1	Output 1	Input high level

Notes 1. P121 to P124 and P137 are read-only.

2. P137: Undefined

P130: 0 (output latch)

Caution Be sure to set bits that are not mounted to their initial values.

Remark m = 0 to 15; n = 0 to 7

4.3.3 Pull-up resistor option registers (PUxx)

These registers specify whether the on-chip pull-up resistors are to be used or not. On-chip pull-up resistors can be used in 1-bit units only for the bits set to both normal output mode (POMmn = 0) and input mode (PMmn = 1) for the pins to which the use of an on-chip pull-up resistor has been specified in these registers. On-chip pull-up resistors cannot be connected to bits set to output mode and bits used as alternate-function output pins and analog setting (PMC = 1, ADPC = 1), regardless of the settings of these registers.

These registers can be set by a 1-bit or 8-bit memory manipulation instruction.
 Reset signal generation clears these registers to 00H (Only PU4 is set to 01H).

Caution When a port with the PIMn register is input from a different potential device to the TTL buffer, pull up to the power supply of the different potential device via an external resistor by setting PUm_n = 0.

Figure 4-3. Format of Pull-up Resistor Option Register

Symbol	7	6	5	4	3	2	1	0	Address	After reset	R/W
PU0	PU07	PU06	PU05	PU04	PU03	PU02	PU01	PU00	F0030H	00H	R/W
PU1	PU17	PU16	PU15	PU14	PU13	PU12	PU11	PU10	F0031H	00H	R/W
PU3	PU37	PU36	PU35	PU34	PU33	PU32	PU31	PU30	F0033H	00H	R/W
PU4	PU47	PU46	PU45	PU44	PU43	PU42	PU41	PU40	F0034H	01H	R/W
PU5	PU57	PU56	PU55	PU54	PU53	PU52	PU51	PU50	F0035H	00H	R/W
PU6	PU67	PU66	PU65	PU64	0	0	0	0	F0036H	00H	R/W
PU7	PU77	PU76	PU75	PU74	PU73	PU72	PU71	PU70	F0037H	00H	R/W
PU8	PU87	PU86	PU85	PU84	PU83	PU82	PU81	PU80	F0038H	00H	R/W
PU9	PU97	PU96	PU95	PU94	PU93	PU92	PU91	PU90	F0039H	00H	R/W
PU10	0	PU106	PU105	PU104	PU103	PU102	PU101	PU100	F003AH	00H	R/W
PU11	PU117	PU116	PU115	PU114	PU113	PU112	PU111	PU110	F003BH	00H	R/W
PU12	PU127	PU126	PU125	0	0	0	0	PU120	F003CH	00H	R/W
PU14	PU147	PU146	PU145	PU144	PU143	PU142	PU141	PU140	F003EH	00H	R/W

PU _m _n	P _m n pin on-chip pull-up resistor selection (m = 0, 1, 3 to 12, 14; n = 0 to 7)
0	On-chip pull-up resistor not connected
1	On-chip pull-up resistor connected

Caution Be sure to set bits that are not mounted to their initial values.

4.3.4 Port input mode registers (PIMxx)

These registers set the input buffer in 1-bit units.

TTL input buffer can be selected during serial communication with an external device of the different potential.

Port input mode registers can be set by a 1-bit or 8-bit memory manipulation instruction.

Reset signal generation clears these registers to 00H.

Figure 4-4. Format of Port Input Mode Register

Symbol	7	6	5	4	3	2	1	0	Address	After reset	R/W
PIM0	0	0	0	PIM04	PIM03	0	PIM01	0	F0040H	00H	R/W
PIM1	PIM17	PIM16	PIM15	PIM14	PIM13	0	PIM11	PIM10	F0041H	00H	R/W
PIM4	0	0	0	PIM44	PIM43	0	0	0	F0044H	00H	R/W
PIM5	0	0	PIM55	PIM54	PIM53	0	0	0	F0045H	00H	R/W
PIM8	0	0	0	0	0	0	PIM81	PIM80	F0048H	00H	R/W
PIM14	0	0	0	0	PIM143	PM142	0	0	F004EH	00H	R/W
PIMmn	Pmn pin input buffer selection (m = 0, 1, 4, 5, 8, 14; n = 0 to 7)										
0	Normal input buffer										
1	TTL input buffer										

Caution Be sure to set bits that are not mounted to their initial values.

4.3.5 Port output mode registers (POMxx)

These registers set the output mode in 1-bit units.

N-ch open drain output (V_{DD} tolerance ^{Note 1}/ EV_{DD} tolerance ^{Note 2}) mode can be selected during serial communication with an external device of the different potential, and for the SDA00, SDA01, SDA10, SDA11, SDA20, SDA21, SDA30, and SDA31 pins during simplified I²C communication with an external device of the same potential.

In addition, POMxx register is set with PUxx register, whether or not to use the on-chip pull-up resistor.

These registers can be set by a 1-bit or 8-bit memory manipulation instruction.

Reset signal generation clears these registers to 00H.

Caution An on-chip pull-up resistor is not connected to a bit for which N-ch open drain output (V_{DD} tolerance ^{Note 1}/ EV_{DD} tolerance ^{Note 2}) mode is set.

Figure 4-5. Format of Port Input Mode Register

Symbol	7	6	5	4	3	2	1	0	Address	After reset	R/W
POM0	0	0	0	POM04	POM03	POM02	0	POM00	F0050H	00H	R/W
POM1	POM17	0	POM15	POM14	POM13	POM12	POM11	POM10	F0051H	00H	R/W
POM4	0	0	POM45	POM44	POM43	0	0	0	F0054H	00H	R/W
POM5	0	0	POM55	POM54	POM53	POM52	0	POM50	F0055H	00H	R/W
POM7	0	0	0	POM74	0	0	POM71	0	F0057H	00H	R/W
POM8	0	0	0	0	0	POM82	POM81	POM80	F0058H	00H	R/W
POM9	0	POM96	0	0	0	0	0	0	F0059H	00H	R/W
POM14	0	0	0	POM144	POM143	POM142	0	0	F005EH	00H	R/W

POMmn	Pmn pin output mode selection (m = 0, 1, 4, 5, 7 to 9, 14; n = 0 to 7)
0	Normal output mode
1	N-ch open-drain output (V_{DD} tolerance ^{Note 1} / EV_{DD} tolerance ^{Note 2}) mode

- Notes**
1. For 20- to 52-pin products
 2. For 64- to 128-pin products

Caution Be sure to set bits that are not mounted to their initial values.

4.3.6 Port mode control registers (PMCxx)

These registers set the digital I/O/analog input in 1-bit units.

These registers can be set by a 1-bit or 8-bit memory manipulation instruction.

Reset signal generation clears these registers to FFH.

Figure 4-6. Format of Port Mode Control Register

Symbol	7	6	5	4	3	2	1	0	Address	After reset	R/W
PMC0	1	1	1	1	PMC03	PMC02	PMC01	PMC00	F0060H	FFH	R/W
PMC3	PMC37	PMC36	PMC35	1	1	1	1	1	F0063H	FFH	R/W
PMC10	1	1	1	1	1	1	1	PMC100	F006AH	FFH	R/W
PMC11	PMC117	PMC116	PMC115	1	1	1	1	1	F006BH	FFH	R/W
PMC12	1	1	1	1	1	1	1	PMC120	F006CH	FFH	R/W
PMC14	PMC147	1	1	1	1	1	1	1	F006EH	FFH	R/W
PMCmn	Pmn pin digital I/O/analog input selection (m = 0, 3, 10 to 12, 14; n = 0 to 3, 5 to 7)										
0	Digital I/O (alternate function other than analog input)										
1	Analog input										

- Cautions**
1. Select input mode by using port mode registers 0, 3, 10 to 12, 14 (PM0, PM3, PM10 to PM12, PM14) for the ports which are set by the PMCxx register as analog input.
 2. Do not set the pin set by the PMCxx register as digital I/O by the analog input channel specification register (ADS).
 3. Be sure to set bits that are not mounted to their initial values.

4.3.7 A/D port configuration register (ADPC)

This register switches the P20/ANI0 to P27/ANI7, and P150/ANI8 to P156/ANI14 pins to digital I/O of port or analog input of A/D converter.

The ADPC register can be set by an 8-bit memory manipulation instruction.

Reset signal generation sets this register to 00H.

Figure 4-7. Format of A/D Port Configuration Register (ADPC)

Address: F0076H After reset: 00H R/W

Symbol	7	6	5	4	3	2	1	0
ADPC	0	0	0	0	ADPC3	ADPC2	ADPC1	ADPC0

ADPC3	ADPC2	ADPC1	ADPC0	Analog input (A)/digital I/O (D) switching															
				ANI14/P156	ANI13/P155	ANI12/P154	ANI11/P153	ANI10/P152	ANI9/P151	ANI8/P150	ANI7/P27	ANI6/P26	ANI5/P25	ANI4/P24	ANI3/P23	ANI2/P22	ANI1/P21	ANI0/P20	
0	0	0	0	A	A	A	A	A	A	A	A	A	A	A	A	A	A	A	
0	0	0	1	D	D	D	D	D	D	D	D	D	D	D	D	D	D	D	
0	0	1	0	D	D	D	D	D	D	D	D	D	D	D	D	D	D	A	
0	0	1	1	D	D	D	D	D	D	D	D	D	D	D	D	D	D	A	
0	1	0	0	D	D	D	D	D	D	D	D	D	D	D	D	A	A	A	
0	1	0	1	D	D	D	D	D	D	D	D	D	D	D	A	A	A	A	
0	1	1	0	D	D	D	D	D	D	D	D	D	D	A	A	A	A	A	
0	1	1	1	D	D	D	D	D	D	D	D	D	A	A	A	A	A	A	
1	0	0	0	D	D	D	D	D	D	D	D	A	A	A	A	A	A	A	
1	0	0	1	D	D	D	D	D	D	D	A	A	A	A	A	A	A	A	
1	0	1	0	D	D	D	D	D	D	A	A	A	A	A	A	A	A	A	
1	0	1	1	D	D	D	D	D	A	A	A	A	A	A	A	A	A	A	
1	1	0	0	D	D	D	D	A	A	A	A	A	A	A	A	A	A	A	
1	1	0	1	D	D	D	A	A	A	A	A	A	A	A	A	A	A	A	
1	1	1	0	D	D	A	A	A	A	A	A	A	A	A	A	A	A	A	
1	1	1	1	D	A	A	A	A	A	A	A	A	A	A	A	A	A	A	

- Cautions**
1. Set the port to analog input by ADPC register to the input mode by using port mode registers 2,15 (PM2, PM15).
 2. Do not set the pin set by the ADPC register as digital I/O by the analog input channel specification register (ADS).
 3. When using AV_{REFP} and AV_{REFM}, set ANI0 and ANI1 to analog input and set the port mode register to the input mode.

4.3.8 Peripheral I/O redirection register (PIOR)

This register is used to specify whether to enable or disable the peripheral I/O redirect function.

This function is used to switch ports to which alternate functions are assigned.

Use the PIOR register to assign a port to the function to redirect and enable the function.

In addition, the settings for redirection can be changed only until operation of the function is enabled.

The PIOR register can be set by an 8-bit memory manipulation instruction.

Reset signal generation sets this register to 00H.

Figure 4-8. Format of Peripheral I/O Redirection Register (PIOR)

Address: F0077H After reset: 00H R/W

Symbol	7	6	5	4	3	2	1	0
PIOR	0	0	PIOR5	PIOR4	PIOR3	PIOR2	PIOR1	PIOR0

Bit	Alternative function	128/100-pin		80-pin		64-pin		52-pin		48-pin		44-pin		40/36/32/30-pin	
		Setting value		Setting value		Setting value		Setting value		Setting value		Setting value		Setting value	
		0	1	0	1	0	1	0	1	0	1	0	1	0	1
PIOR5	INTP1	P46	P56	These functions are not available for use. Set this bit to 0 (default value).											
	INTP3	P30	P57												
	INTP4	P31	P146												
	INTP6	P140	P84												
	INTP7	P141	P85												
	INTP8	P74	P86												
	INTP9	P75	P87												
	TxD1	P02	P82												
	RxD1	P03	P81												
	SCL10	P04	P80												
	SDA10	P03	P81												
	SI10	P03	P81												
	SO10	P02	P82												
SCK10	P04	P80													
PIOR4	PCLBUZ1	P141	P55	P141	P55	P141	P55								
	INTP5	P16	P12	P16	P12	P16	P12								
PIOR3	PCLBUZ0	P140	P31	P140	P31	P140	P31	P140	P31	P140	P31				
PIOR2	SCLA0	P60	P14	P60	P14	P60	P14	P60	P14	P60	P14	P60	P14	P60	P14
	SDAA0	P61	P13	P61	P13	P61	P13	P61	P13	P61	P13	P61	P13	P61	P13
PIOR1	INTP10	P76	P110	P76	P110	P76	P52	P76	-	-	-	-	-	-	-
	INTP11	P77	P111	P77	P111	P77	P53	P77	-	-	-	-	-	-	-
	TxD2	P13	P77	P13	P77	P13	P77	P13	P77	P13	-	P13	-	P13	-
	RxD2	P14	P76	P14	P76	P14	P76	P14	P76	P14	-	P14	-	P14	-
	SCL20	P15	-	P15	-	P15	-	P15	-	P15	-	P15	-	P15	-
	SDA20	P14	-	P14	-	P14	-	P14	-	P14	-	P14	-	P14	-
	SI20	P14	-	P14	-	P14	-	P14	-	P14	-	P14	-	P14	-
	SO20	P13	-	P13	-	P13	-	P13	-	P13	-	P13	-	P13	-
	SCK20	P15	-	P15	-	P15	-	P15	-	P15	-	P15	-	P15	-
	TxD0	P12	P17	P12	P17	P12	P17	P12	P17	P12	P17	P12	P17	P12	P17
	RxD0	P11	P16	P11	P16	P11	P16	P11	P16	P11	P16	P11	P16	P11	P16
	SCL00	P10	-	P10	-	P10	-	P10	-	P10	-	P10	-	P10	-
	SDA00	P11	-	P11	-	P11	-	P11	-	P11	-	P11	-	P11	-
SI00	P11	P16	P11	P16	P11	P16	P11	-	P11	-	P11	-	P11	-	
SO00	P12	P17	P12	P17	P12	P17	P12	-	P12	-	P12	-	P12	-	
SCK00	P10	P55	P10	P55	P10	P55	P10	-	P10	-	P10	-	P10	-	
PIOR0	TI02/TO02	P17	P15	P17	P15	P17	P15	P17	P15	P17	P15	P17	P15	P17	P15
	TI03/TO03	P31	P14	P31	P14	P31	P14	P31	P14	P31	P14	P31	P14	P31	P14
	TI04/TO04	P42	P13	P42	P13	P42	P13	-	P13	-	P13	-	P13	-	P13
	TI05/TO05	P46	P12	P05	P12	P05	P12	-	P12	-	P12	-	P12	-	P12
	TI06/TO06	P102	P11	P06	P11	P06	P11	-	P11	-	P11	-	P11	-	P11
	TI07/TO07	P145	P10	P41	P10	P41	P10	P41	P10	P41	P10	P41	P10	-	P10

Caution For 20- to 25-pin products, the PIOR register is not mounted.

Remark -: These functions are not available for use.

4.3.9 Global digital input disable register (GDIDIS)

This register is used to prevent through-current flowing from the input buffers of input ports which use EV_{DD} as the power supply when the EV_{DD} power supply is turned off.

When not all of the I/O ports using EV_{DD} as the power supply are used, low power consumption can be achieved by setting the GDIDIS register (setting the GDIDIS0 bit to 1) to turn off the EV_{DD} power supply.

By setting the GDIDIS0 bit to 1, input to any input buffer using EV_{DD} as the power supply is prohibited, preventing through-current from flowing when the EV_{DD} power supply is turned off.

The GDIDIS register can be set by a 1-bit or 8-bit memory manipulation instruction.

Reset signal generation sets this register to 00H.

Remark The GDIDIS register is equipped with 64-, 80-, 100-, 128-pin products.

Figure 4-9. Format of Global Digital Input Disable Register (GDIDIS)

Address: F007DH After reset: 00H R/W

Symbol	7	6	5	4	3	2	1	0
GDIDIS	0	0	0	0	0	0	0	GDIDIS0

GDIDIS0	Setting of input buffers using EV _{DD} power supply
0	Input to input buffers permitted (default)
1	Input to input buffers prohibited. No through-current flows to the input buffers.

Turn off the EV_{DD} power supply with the following procedure.

1. Prohibit input to input buffers (set GDIDIS0 = 1).
2. Turn off the EV_{DD} power supply.

Turn on again the EV_{DD} power supply with the following procedure.

1. Turn on the EV_{DD} power supply.
2. Permit input to input buffers (set GDIDIS0 = 0).

- Cautions**
1. Do not input an input voltage equal to or greater than EV_{DD} to an input port that uses EV_{DD} as the power supply.
 2. When input to input buffers is prohibited (GDIDIS0 = 1), the value read from the port register (Pxx) of a port that uses EV_{DD} as the power supply is 1. When 1 is set in the port output mode register (POMxx) (N-ch open drain output (EV_{DD} tolerance) mode), the value read from the port register (Pxx) is 0.

- Remarks**
1. The GDIDIS register is equipped with 64-, 80-, 100-, 128-pin products.
 2. Even when input to input buffers is prohibited (GDIDIS0 = 1), peripheral functions which do not use port functions having EV_{DD} as the power supply can be used.

4.4 Port Function Operations

Port operations differ depending on whether the input or output mode is set, as shown below.

4.4.1 Writing to I/O port

(1) Output mode

A value is written to the output latch by a transfer instruction, and the output latch contents are output from the pin.

Once data is written to the output latch, it is retained until data is written to the output latch again.

The data of the output latch is cleared when a reset signal is generated.

(2) Input mode

A value is written to the output latch by a transfer instruction, but since the output buffer is off, the pin status does not change. Therefore, byte data can be written to the ports used for both input and output.

Once data is written to the output latch, it is retained until data is written to the output latch again.

The data of the output latch is cleared when a reset signal is generated.

4.4.2 Reading from I/O port

(1) Output mode

The output latch contents are read by a transfer instruction. The output latch contents do not change.

(2) Input mode

The pin status is read by a transfer instruction. The output latch contents do not change.

4.4.3 Operations on I/O port

(1) Output mode

An operation is performed on the output latch contents, and the result is written to the output latch. The output latch contents are output from the pins.

Once data is written to the output latch, it is retained until data is written to the output latch again.

The data of the output latch is cleared when a reset signal is generated.

(2) Input mode

The pin level is read and an operation is performed on its contents. The result of the operation is written to the output latch, but since the output buffer is off, the pin status does not change. Therefore, byte data can be written to the ports used for both input and output.

The data of the output latch is cleared when a reset signal is generated.

4.4.4 Handling different potential (1.8 V, 2.5 V, 3 V) by using $EV_{DD} \leq V_{DD}$

When connecting an external device operating on a different potential (1.8 V, 2.5 V or 3 V), it is possible to connect the I/O pins of general ports by changing EV_{DD} to accord with the power supply of the connected device.

4.4.5 Handling different potential (1.8 V, 2.5 V, 3 V) by using I/O buffers

It is possible to connect an external device operating on a different potential (1.8 V, 2.5 V or 3 V) by switching I/O buffers with the port input mode register (PIMxx) and port output mode register (POMxx).

When receiving input from an external device with a different potential (1.8 V, 2.5 V or 3 V), set the port input mode registers 0, 1, 4, 5, 8, and 14 (PIM0, PIM1, PIM4, PIM5, PIM8, and PIM14) on a bit-by-bit basis to enable normal input (CMOS)/TTL input buffer switching.

When outputting data to an external device with a different potential (1.8 V, 2.5 V or 3 V), set the port output mode registers 0, 1, 4, 5, 8, and 14 (POM0, POM1, POM4, POM5, POM8, and POM14) on a bit-by-bit basis to enable normal output (CMOS)/N-ch open drain (V_{DD} tolerance ^{Note 1}/ EV_{DD} tolerance ^{Note 2}) switching.

The connection of a serial interface is described in the following.

- Notes 1.** For 20- to 52-pin products
2. For 64- to 128-pin products

(1) Setting procedure when using input pins of UART0 to UART3, CSI00, CSI01, CSI10, CSI20, CSI30, and CSI31 functions for the TTL input buffer

In case of UART0:	P11 (P16)
In case of UART1:	P03 (P81)
In case of UART2:	P14
In case of UART3:	P143
In case of CSI00:	P10, P11 (P16, P55)
In case of CSI01:	P43, P44
In case of CSI10:	P03, P04 (P80, P81)
In case of CSI20:	P14, P15
In case of CSI30:	P142, P143
In case of CSI31:	P53, P54

Remark Functions in parentheses can be assigned via settings in the peripheral I/O redirection register (PIOR).

- <1> Using an external resistor, pull up externally the pin to be used to the power supply of the target device (on-chip pull-up resistor cannot be used).
- <2> Set the corresponding bit of the PIM0, PIM1, PIM4, PIM5, PIM8, and PIM14 registers to 1 to switch to the TTL input buffer. For V_{IH} and V_{IL} , refer to the DC characteristics when the TTL input buffer is selected.
- <3> Enable the operation of the serial array unit and set the mode to the UART/Simplified SPI (CSI^{Note}) mode.

Note Although the CSI function is generally called SPI, it is also called CSI in this product, so it is referred to as such in this manual.

(2) Setting procedure when using output pins of UART0 to UART3, CSI00, CSI01, CSI10, CSI20, CSI30, and CSI31 functions in N-ch open-drain output mode

In case of UART0:	P12 (P17)
In case of UART1:	P02 (P82)
In case of UART2:	P13
In case of UART3:	P144
In case of CSI00:	P10, P12 (P17, P55)
In case of CSI01:	P43, P45
In case of CSI10:	P02, P04 (P80, P82)
In case of CSI20:	P13, P15
In case of CSI30:	P142, P144
In case of CSI31:	P52, P54

Remark Functions in parentheses can be assigned via settings in the peripheral I/O redirection register (PIOR).

- <1> Using an external resistor, pull up externally the pin to be used to the power supply of the target device (on-chip pull-up resistor cannot be used).
- <2> After reset release, the port mode is the input mode (Hi-Z).
- <3> Set the output latch of the corresponding port to 1.
- <4> Set the corresponding bit of the POM0, POM1, POM4, POM5, and POM14 registers to 1 to set the N-ch open drain output (V_{DD} tolerance ^{Note 1}/ EV_{DD} tolerance ^{Note 2}) mode.
- <5> Enable the operation of the serial array unit and set the mode to the UART/Simplified SPI (CSI) mode.
- <6> Set the corresponding bit of the PM0, PM1, PM4, PM5, and PM14 registers to the output mode. At this time, the output data is high level, so the pin is in the Hi-Z state.

- Notes**
1. For 20- to 52-pin products
 2. For 64- to 128-pin products

(3) Setting procedure when using I/O pins of IIC00, IIC01, IIC10, IIC20, IIC30, and IIC31 functions with a different potential (1.8 V, 2.5 V, 3 V)

In case of IIC00:	P10, P11
In case of IIC01:	P43, P44
In case of IIC10:	P03, P04 (P80, P81)
In case of IIC20:	P14, P15
In case of IIC30:	P142, P143
In case of IIC31:	P53, P54

Remark Functions in parentheses can be assigned via settings in the peripheral I/O redirection register (PIOR).

- <1> Using an external resistor, pull up externally the pin to be used to the power supply of the target device (on-chip pull-up resistor cannot be used).
- <2> After reset release, the port mode is the input mode (Hi-Z).
- <3> Set the output latch of the corresponding port to 1.
- <4> Set the corresponding bit of the POM0, POM1, POM4, POM5, and POM14 registers to 1 to set the N-ch open drain output (V_{DD} tolerance ^{Note 1}/ EV_{DD} tolerance ^{Note 2}) mode.
- <5> Set the corresponding bit of the PIM0, PIM1, PIM4, PIM5, PIM8, and PIM14 registers to 1 to switch to the TTL input buffer. For V_{IH} and V_{IL} , refer to the DC characteristics when the TTL input buffer is selected.
- <6> Enable the operation of the serial array unit and set the mode to the simplified I²C mode.
- <7> Set the corresponding bit of the PM0, PM1, PM4, PM5, and PM14 registers to the output mode (data I/O is possible in the output mode). At this time, the output data is high level, so the pin is in the Hi-Z state.

- Notes**
1. For 20- to 52-pin products
 2. For 64- to 128-pin products

4.5 Register Settings When Using Alternate Function

4.5.1 Basic concept when using alternate function

In the beginning, for a pin also assigned to be used for analog input, use the ADPC register or port mode control register (PMCxx) to specify whether to use the pin for analog input or digital input/output.

Figure 4-10 shows the basic configuration of an output circuit for pins used for digital input/output. The output of the output latch for the port and the output of the alternate SAU function are input to an AND gate. The output of the AND gate is input to an OR gate. The output of an alternate function other than SAU (TAU, RTC, clock/buzzer output, IICA, etc.) is connected to the other input pin of the OR gate. When such kind of pins are used by the port function or an alternate function, the unused alternate function must not hinder the output of the function to be used. An idea of basic settings for this kind of case is shown in Table 4-6.

Figure 4-10. Basic Configuration of Output Circuit for Pins

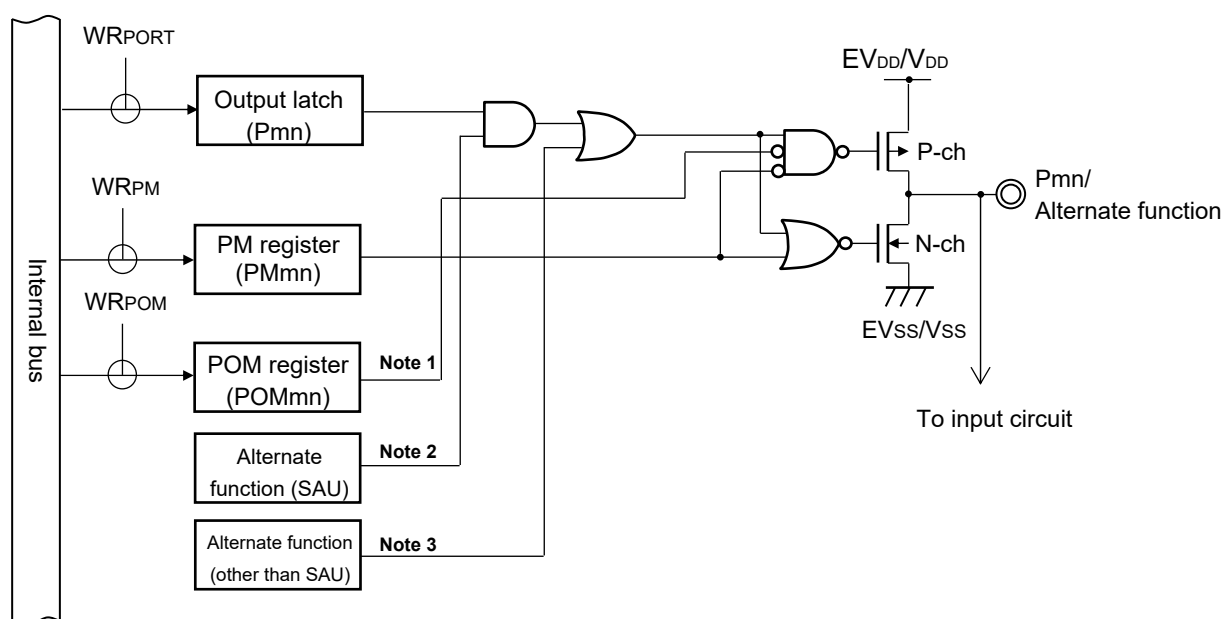

- Notes 1.** When there is no POM register, this signal should be considered to be low level (0).
2. When there is no alternate function, this signal should be considered to be high level (1).
3. When there is no alternate function, this signal should be considered to be low level (0).

Remark m: Port number (m = 0 to 15); n: Bit number (n = 0 to 7)

Table 4-6. Concept of Basic Settings

Output Function of Used Pin	Output Settings of Unused Alternate Function		
	Output Function for Port	Output Function for SAU	Output Function for other than SAU
Output function for port	—	Output is high (1)	Output is low (0)
Output function for SAU	High (1)	—	Output is low (0)
Output function for other than SAU	Low (0)	Output is high (1)	Output is low (0) ^{Note}

Note Since more than one output function other than SAU may be assigned to a single pin, the output of an unused alternate function must be set to low level (0). For details on the setting method, see **4.5.2 Register settings for alternate function whose output function is not used**.

4.5.2 Register settings for alternate function whose output function is not used

When the output of an alternate function of the pin is not used, the following settings should be made. Note that when the peripheral I/O redirection function is the target, the output can be switched to another pin by setting the peripheral I/O redirection register (PIOR). This allows usage of the port function or other alternate function assigned to the target pin.

(1) $SOp = 1, TxDq = 1$ (settings when the serial output (SO_p/Tx_{Dq}) of SAU is not used)

When the serial output (SO_p/Tx_{Dq}) is not used, such as, a case in which only the serial input of SAU is used, set the bit in serial output enable register *m* (SO_{Em}) which corresponds to the unused output to 0 (output disabled) and set the SO_{mn} bit in serial output register *m* (SO_m) to 1 (high). These are the same settings as the initial state.

(2) $SCKp = 1, SDAr = 1, SCLr = 1$ (settings when channel *n* in SAU is not used)

When SAU is not used, set bit *n* (SE_{mn}) in serial channel enable status register *m* (SE_m) to 0 (operation stopped state), set the bit in serial output enable register *m* (SO_{Em}) which corresponds to the unused output to 0 (output disabled), and set the SO_{mn} and CKO_{mn} bits in serial output register *m* (SO_m) to 1 (high). These are the same settings as the initial state.

(3) $TOmn = 0$ (settings when the output of channel *n* in TAU is not used)

When the TO_{mn} output of TAU is not used, set the bit in timer output enable register 0 (TOE0) which corresponds to the unused output to 0 (output disabled) and set the bit in timer output register 0 (TO0) to 0 (low). These are the same settings as the initial state.

(4) $SDAAn = 0, SCLAn = 0$ (setting when IICA is not used)

When IICA is not used, set the IICEn bit in IICA control register *n*0 (IICCTLn0) to 0 (operation stopped). This is the same setting as the initial state.

(5) $PCLBUZn = 0$ (setting when clock/buzzer output is not used)

When the clock/buzzer output is not used, set the PCLOEn bit in clock output select register *n* (CKSn) to 0 (output disabled). This is the same setting as the initial state.

4.5.3 Register setting examples for used port and alternate functions

Register setting examples for used port and alternate functions are shown in Table 4-7. The registers used to control the port functions should be set as shown in Table 4-7. See the following remark for legends used in Table 4-7.

Remark —: Not supported

x: don't care

PIORx: Peripheral I/O redirection register

POMxx: Port output mode register

PMCxx: Port mode control register

PMxx: Port mode register

Pxx: Port output latch

Functions in parentheses can be assigned via settings in the peripheral I/O redirection register (PIOR).

Table 4-7. Setting Examples of Registers and Output Latches When Using Alternate Function (1/21)

Pin Name	Used Function		PIORx ^{Note 1}	POMxx	PMCxx	PMxx	Pxx	Alternate Function Output		20-pin	24-pin	25-pin	30-pin	32-pin	36-pin	40-pin	44-pin	48-pin	52-pin	64-pin	80-pin	100-pin	128-pin	
	Function Name	I/O						SAU Output Function	Other than SAU															
P00	P00	Input	–	x	0 ^{Note 2}	1	x	x	–															
		Output	–	0	0 ^{Note 2}	0	0/1	TxD1 = 1 ^{Note 3}	–	√	√	√	√	√	√	√	√	√	√	√	√	√	√	√
		N-ch open drain output	–	1	0 ^{Note 2}	0	0/1		–															
	ANI17	Analog input	–	x	1	1	x	x	–	√	√	√	√	√	x	x	x	x	x	x	x	x	x	x
	TI00	Input	–	x	0 ^{Note 2}	1	x	x	–	√	√	√	√	√	√	√	√	√	√	√	√	√	√	√
	TxD1	Output	–	0/1	0 ^{Note 2}	0	1	x	–	√	√	√	√	√	√	√	√	√	x	x	x	x	x	x
P01	P01	Input	–	–	0 ^{Note 2}	1	x	x	x	√	√	√	√	√	√	√	√	√	√	√	√	√	√	√
		Output	–	–	0 ^{Note 2}	0	0/1	–	TO00 = 0															
	ANI16	Analog input	–	–	1	1	x	x	x	√	√	√	√	√	x	x	x	x	x	x	x	x	x	x
	TO00	Output	–	–	0 ^{Note 2}	0	0	–	x	√	√	√	√	√	√	√	√	√	√	√	√	√	√	√
	RxD1	Input	–	–	0 ^{Note 2}	1	x	–	x	√	√	√	√	√	√	√	√	√	x	x	x	x	x	x
P02	P02	Input	–	x	0	1	x	x	–	x	x	x	x	x	x	x	x	x	√	√	√	√	√	√
		Output	–	0	0	0	0/1	TxD1/ SO10 = 1	–															
		N-ch open drain output	–	1	0	0	0/1		–															
	ANI17	Analog input	–	–	1	1	x	x	–	x	x	x	x	x	x	x	x	x	√	√	√	√	√	
	TxD1	Output	PIOR5= 0 ^{Note 4}	0/1	0	0	1	x	–	x	x	x	x	x	x	x	x	x	√	√	√	√	√	
	SO10	Output	PIOR5= 0 ^{Note 4}	0/1	0	0	1	x	–	x	x	x	x	x	x	x	x	x	x	√	√	√	√	
P03	P03	Input	–	x	0	1	x	x	–	x	x	x	x	x	x	x	x	x	√	√	√	√	√	√
		Output	–	0	0	0	0/1	SDA10 = 1 ^{Note 5}	–															
		N-ch open drain output	–	1	0	0	0/1		–															
	ANI16	Analog input	–	–	1	1	x	x	–	x	x	x	x	x	x	x	x	x	√	√	√	√	√	
	SI10	Input	PIOR5= 0 ^{Note 4}	–	0	1	x	x	–	x	x	x	x	x	x	x	x	x	x	√	√	√	√	
	RxD1	Input	PIOR5= 0 ^{Note 4}	–	0	1	x	x	–	x	x	x	x	x	x	x	x	x	√	√	√	√	√	
	SDA10	I/O	PIOR5= 0 ^{Note 4}	–	0	0	1	x	–	x	x	x	x	x	x	x	x	x	x	√	√	√	√	

- Notes**
- 30- to 128-pin products only
 - 20- to 32-pin products only
 - 20- to 48-pin products only
 - 100- and 128-pin products only
 - 64- to 128-pin products only

Table 4-7. Setting Examples of Registers and Output Latches When Using Alternate Function (2/21)

Pin Name	Used Function		PIORx ^{Note 1}	POMxx	PMCxx	PMxx	Pxx	Alternate Function Output		20-pin	24-pin	25-pin	30-pin	32-pin	36-pin	40-pin	44-pin	48-pin	52-pin	64-pin	80-pin	100-pin	128-pin	
	Function Name	I/O						SAU Output Function	Other than SAU															
P04	P04	Input	–	x	–	1	x	x	–															
		Output	–	0	–	0	0/1	SCK10/SCL10 = 1	–	x	x	x	x	x	x	x	x	x	x	x	√	√	√	√
		N-ch open drain output	–	1	–	0	0/1		–															
	SCK10	Input	PIOR5 = 0 ^{Note 2}	x	–	1	x	x	–	x	x	x	x	x	x	x	x	x	x	x	√	√	√	√
		Output	PIOR5 = 0 ^{Note 2}	0/1	–	0	1	x	–	x	x	x	x	x	x	x	x	x	x	x	√	√	√	√
SCL10	Output	PIOR5 = 0 ^{Note 2}	0/1	–	0	1	x	–	x	x	x	x	x	x	x	x	x	x	x	√	√	√	√	
P05	P05	Input	–	–	–	1	x	–	x															
		Output	–	–	–	0	0/1	–	TO05 = 0 ^{Note 3}	x	x	x	x	x	x	x	x	x	x	x	√	√	√	√
	TI05	Input	PIOR0 = 0 ^{Note 3}	–	–	1	x	–	x	x	x	x	x	x	x	x	x	x	x	√	√	x	x	
	TO05	Output	PIOR0 = 0 ^{Note 3}	–	–	0	0	–	x	x	x	x	x	x	x	x	x	x	x	√	√	x	x	
P06	P06	Input	–	–	–	1	x	–	x															
		Output	–	–	–	0	0/1	–	TO06 = 0 ^{Note 3}	x	x	x	x	x	x	x	x	x	x	x	√	√	√	√
	TI06	Input	PIOR0 = 0 ^{Note 3}	–	–	1	x	–	x	x	x	x	x	x	x	x	x	x	x	√	√	x	x	
	TO06	Output	PIOR0 = 0 ^{Note 3}	–	–	0	0	–	x	x	x	x	x	x	x	x	x	x	x	√	√	x	x	
P07	P07	Input	–	–	–	1	x	–	–	x	x	x	x	x	x	x	x	x	x	x	x	x	√	
		Output	–	–	–	0	0/1	–	–															
P10	P10	Input	–	x	–	1	x	x	x															
		Output	–	0	–	0	0/1	SCK00/SCL00 = 1	(TO07) = 0 ^{Note 1}	√	√	√	√	√	√	√	√	√	√	√	√	√	√	√
		N-ch open drain output	–	1	–	0	0/1		–															
	SCK00	Input	PIOR1 = 0	x	–	1	x	x	x	√	√	√	√	√	√	√	√	√	√	√	√	√	√	√
		Output	PIOR1 = 0	0/1	–	0	1	x	(TO07) = 0 ^{Note 1}	√	√	√	√	√	√	√	√	√	√	√	√	√	√	√
	SCL00	Output	PIOR1 = 0	0/1	–	0	1	x	(TO07) = 0 ^{Note 1}	√	√	√	√	√	√	√	√	√	√	√	√	√	√	√
	(TI07)	Input	PIOR0 = 1	x	–	1	x	x	x	x	x	x	√	√	√	√	√	√	√	√	√	√	√	√
(TO07)	Output	PIOR0 = 1	0	–	0	0	SCK00/SCL00 = 1	x	x	x	x	√	√	√	√	√	√	√	√	√	√	√	√	

- Notes 1. 30- to 128-pin products only
 2. 100- and 128-pin products only
 3. 64- and 80-pin products only

Table 4-7. Setting Examples of Registers and Output Latches When Using Alternate Function (3/21)

Pin Name	Used Function		PIORx ^{Note}	POMxx	PMCxx	PMxx	Pxx	Alternate Function Output		20-pin	24-pin	25-pin	30-pin	32-pin	36-pin	40-pin	44-pin	48-pin	52-pin	64-pin	80-pin	100-pin	128-pin		
	Function Name	I/O						SAU Output Function	Other than SAU																
P11	P11	Input	–	x	–	1	x	x	x																
		Output	–	0	–	0	0/1	SDA00 = 1	(TO06) = 0 ^{Note}	√	√	√	√	√	√	√	√	√	√	√	√	√	√	√	√
		N-ch open drain output	–	1	–	0	0/1	SDA00 = 1	(TO06) = 0 ^{Note}																
	S100	Output	PIOR1 = 0	x	–	1	x	x	x	√	√	√	√	√	√	√	√	√	√	√	√	√	√	√	√
	RxD0	Input	PIOR1 = 0	x	–	1	x	x	x	√	√	√	√	√	√	√	√	√	√	√	√	√	√	√	√
	SDA00	I/O	PIOR1 = 0	1	–	0	1	x	(TO06) = 0 ^{Note}	√	√	√	√	√	√	√	√	√	√	√	√	√	√	√	√
	(TI06)	Input	PIOR0 = 1	x	–	1	x	x	x	x	x	x	√	√	√	√	√	√	√	√	√	√	√	√	√
(TO06)	Output	PIOR0 = 1	0	–	0	0	SDA00 = 1	x	x	x	x	√	√	√	√	√	√	√	√	√	√	√	√	√	
P12	P12	Input	–	x	–	1	x	x	x																
		Output	–	0	–	0	0/1	SO00/TxD0 = 1	(TO05) = 0 ^{Note}	√	√	√	√	√	√	√	√	√	√	√	√	√	√	√	√
		N-ch open drain output	–	1	–	0	0/1																		
	SO00	Output	PIOR1 = 0	0/1	–	0	1	x	(TO05) = 0 ^{Note}	√	√	√	√	√	√	√	√	√	√	√	√	√	√	√	√
	TxD0	Output	PIOR1 = 0	0/1	–	0	1	x	(TO05) = 0 ^{Note}	√	√	√	√	√	√	√	√	√	√	√	√	√	√	√	√
	(INTP5)	Input	PIOR4 = 1	x	–	1	x	x	x	x	x	x	x	x	x	x	x	x	x	x	√	√	√	√	√
	(TI05)	Input	PIOR0 = 1	x	–	1	x	x	x	x	x	x	√	√	√	√	√	√	√	√	√	√	√	√	√
(TO05)	Output	PIOR0 = 1	0	–	0	0	SO00/TxD0 = 1	x	x	x	x	√	√	√	√	√	√	√	√	√	√	√	√	√	
P13	P13	Input	–	x	–	1	x	x	x																
		Output	–	0	–	0	0/1			x	x	x	√	√	√	√	√	√	√	√	√	√	√	√	√
		N-ch open drain output	–	1	–	0	0/1	TxD2/SO20 = 1	(TO04) = 0 (SDAA0) = 0																
	TxD2	Output	PIOR1 = 0	0/1	–	0	1	x	(TO04) = 0 (SDAA0) = 0	x	x	x	√	√	√	√	√	√	√	√	√	√	√	√	√
	SO20	Output	PIOR1 = 0	0/1	–	0	1	x	(TO04) = 0 (SDAA0) = 0	x	x	x	√	√	√	√	√	√	√	√	√	√	√	√	√
	(SDAA0)	I/O	PIOR2 = 1	1	–	0	0	TxD2/SO20 = 1	(TO04) = 0	x	x	x	√	√	√	√	√	√	√	√	√	√	√	√	√
	(TI04)	Input	PIOR0 = 1	x	–	1	x	x	x	x	x	x	√	√	√	√	√	√	√	√	√	√	√	√	√
(TO04)	Output	PIOR0 = 1	0	–	0	0	TxD2/SO20 = 1	(SDAA0) = 0	x	x	x	√	√	√	√	√	√	√	√	√	√	√	√	√	

Note 30- to 128-pin products only

Table 4-7. Setting Examples of Registers and Output Latches When Using Alternate Function (4/21)

Pin Name	Used Function		PIORx ^{Note 1}	POMxx	PMCxx	PMxx	Pxx	Alternate Function Output		20-pin	24-pin	25-pin	30-pin	32-pin	36-pin	40-pin	44-pin	48-pin	52-pin	64-pin	80-pin	100-pin	128-pin	
	Function Name	I/O						SAU Output Function	Other than SAU															
P14	P14	Input	–	x	–	1	x	x	x															
		Output	–	0	–	0	0/1	SDA20 = 1	(TO03) = 0 (SCLA0) = 0	x	x	x	√	√	√	√	√	√	√	√	√	√	√	√
		N-ch open drain output	–	1	–	0	0/1																	
	RxD2	Input	PIOR1 = 0	x	–	1	x	x	x	x	x	x	√	√	√	√	√	√	√	√	√	√	√	√
	SI20	Input	PIOR1 = 0	x	–	1	x	x	x	x	x	x	√	√	√	√	√	√	√	√	√	√	√	√
	SDA20	I/O	PIOR1 = 0	1	–	0	1	x	(TO03) = 0 (SCLA0) = 0	x	x	x	√	√	√	√	√	√	√	√	√	√	√	√
	(SCLA0)	I/O	PIOR2 = 1	1	–	0	0	SDA20 = 1	(TO03) = 0	x	x	x	√	√	√	√	√	√	√	√	√	√	√	√
	(TI03)	Input	PIOR0 = 1	x	–	1	x	x	x	x	x	x	√	√	√	√	√	√	√	√	√	√	√	√
(TO03)	Output	PIOR0 = 1	0	–	0	0	SDA20 = 1	(SCLA0) = 0	x	x	x	√	√	√	√	√	√	√	√	√	√	√	√	
P15	P15	Input	–	x	–	1	x	x	x															
		Output	–	0	–	0	0/1	SCK20/SCL20 = 1	PCLBUZ1 = 0 ^{Note 2}	(TO02) = 0	x	x	x	√	√	√	√	√	√	√	√	√	√	√
		N-ch open drain output	–	1	–	0	0/1																	
	PCLBUZ1	Output	–	0	–	0	0	SCK20/SCL20 = 1	(TO02) = 0	x	x	x	√	√	√	√	√	√	√	x	x	x	x	
	SCK20	Input	PIOR1 = 0	x	–	1	x	x	x	x	x	x	√	√	√	√	√	√	√	√	√	√	√	√
		Output	PIOR1 = 0	0/1	–	0	1	x	PCLBUZ1 = 0 ^{Note 2}	(TO02) = 0	x	x	x	√	√	√	√	√	√	√	√	√	√	√
	SCL20	Output	PIOR1 = 0	0/1	–	0	1	x	PCLBUZ1 = 0 ^{Note 2}	(TO02) = 0	x	x	x	√	√	√	√	√	√	√	√	√	√	√
	(TI02)	Input	PIOR0 = 1	x	–	1	x	x	x	x	x	x	√	√	√	√	√	√	√	√	√	√	√	√
(TO02)	Output	PIOR0 = 1	0	–	0	0	SCK20/SCL20 = 1	PCLBUZ1 = 0 ^{Note 2}	x	x	x	√	√	√	√	√	√	√	√	√	√	√	√	

- Notes 1. 30- to 128-pin products only
2. 30- to 52-pin products only

Table 4-7. Setting Examples of Registers and Output Latches When Using Alternate Function (5/21)

Pin Name	Used Function		PIORx ^{Note 1}	POMxx	PMCxx	PMxx	Pxx	Alternate Function Output		20-pin	24-pin	25-pin	30-pin	32-pin	36-pin	40-pin	44-pin	48-pin	52-pin	64-pin	80-pin	100-pin	128-pin	
	Function Name	I/O						SAU Output Function	Other than SAU															
P16	P16	Input	–	–	–	1	x	x	x	√	√	√	√	√	√	√	√	√	√	√	√	√	√	√
		Output	–	–	–	0	0/1	SO11 = 1 ^{Note 2}	TO01 = 0	√	√	√	√	√	√	√	√	√	√	√	√	√	√	√
	TI01	Input	–	–	–	1	x	x	x	√	√	√	√	√	√	√	√	√	√	√	√	√	√	√
	TO01	Output	–	–	–	0	0	SO11 = 1 ^{Note 2}	x	√	√	√	√	√	√	√	√	√	√	√	√	√	√	√
	INTP5	Input	PIOR4 = 0 ^{Note 3}	–	–	1	x	x	x	√	√	√	√	√	√	√	√	√	√	√	√	√	√	√
	SO11	Output	–	–	–	0	1	x	TO01 = 0	√	x	x	x	x	x	x	x	x	x	x	x	x	x	x
	(SI00)	Input	PIOR1 = 1	–	–	1	x	x	x	x	x	x	x	x	x	x	x	x	x	x	√	√	√	√
(RxD0)	Input	PIOR1 = 1	–	–	1	x	x	x	x	x	x	√	√	√	√	√	√	√	√	√	√	√	√	
P17	P17	Input	–	x	–	1	x	x	x															
		Output	–	0	–	0	0/1	SDA11 = 1 ^{Note 2}		√	√													
		N-ch open drain output	–	1	–	0	0/1	SO11 = 1 ^{Note 4} (TxD0) = 1 ^{Note 1} (SO00) = 1 ^{Note 3}	TO02 = 0	√	√	√	√	√	√	√	√	√	√	√	√	√	√	√
	TI02	Input	PIOR0 = 0	x	–	1	x	x	x	√	√	√	√	√	√	√	√	√	√	√	√	√	√	√
	TO02	Output	PIOR0 = 0	0	–	0	0	SDA11 = 1 ^{Note 2} SO11 = 1 ^{Note 4} (TxD0) = 1 ^{Note 1} (SO00) = 1 ^{Note 3}	x	√	√	√	√	√	√	√	√	√	√	√	√	√	√	√
	SI11	Input	–	x	–	1	x	x	x	√	x	x	x	x	x	x	x	x	x	x	x	x	x	x
	SDA11	I/O	–	1	–	0	1	x	TO02 = 0	√	x	x	x	x	x	x	x	x	x	x	x	x	x	x
	SO11	Output	–	0/1	–	0	1	x	TO02 = 0	x	√	√	x	x	x	x	x	x	x	x	x	x	x	x
	(TxD0)	Output	PIOR1 = 1	0/1	–	0	1	x	TO02 = 0	x	x	x	√	√	√	√	√	√	√	√	√	√	√	√
(SO00)	Output	PIOR1 = 1	0/1	–	0	1	x	TO02 = 0	x	x	x	x	x	x	x	x	x	x	x	√	√	√	√	

- Notes**
- 30- to 128-pin products only
 - 20-pin products only
 - 64- to 128-pin products only
 - 24- to 25-pin products only

Table 4-7. Setting Examples of Registers and Output Latches When Using Alternate Function (6/21)

Pin Name	Used Function		ADPC	ADM2	PMxx	Pxx	20-pin	24-pin	25-pin	30-pin	32-pin	36-pin	40-pin	44-pin	48-pin	52-pin	64-pin	80-pin	100-pin	128-pin		
	Function Name	I/O																				
P20	P20	Input	ADPC = 01H	x	1	x	√	√	√	√	√	√	√	√	√	√	√	√	√	√	√	
		Output	ADPC = 01H	x	0	0/1																
	ANI0	Analog input	ADPC = 00H/02H to 0FH	00x0xx0x, 10x0xx0x	1	x	√	√	√	√	√	√	√	√	√	√	√	√	√	√	√	√
	AV _{REFP}	Reference voltage	ADPC = 00H/02H to 0FH	01x0xx0x	1	x	√	√	√	√	√	√	√	√	√	√	√	√	√	√	√	√
P21	P21	Input	ADPC = 01H/02H	x	1	x	√	√	√	√	√	√	√	√	√	√	√	√	√	√	√	
		Output	ADPC = 01H/02H	x	0	0/1																
	ANI1	Analog input	ADPC = 00H/3 to 0FH	xx00xx0x	1	x	√	√	√	√	√	√	√	√	√	√	√	√	√	√	√	√
	AV _{REFM}	Reference voltage	ADPC = 00H/3 to 0FH	xx10xx0x	1	x	√	√	√	√	√	√	√	√	√	√	√	√	√	√	√	√
P22	P22	Input	ADPC = 01H to 03H	x	1	x	√	√	√	√	√	√	√	√	√	√	√	√	√	√	√	
		Output	ADPC = 01H to 03H	x	0	0/1																
	ANI2	Analog input	ADPC = 00H/04H to 0FH	x	1	x	√	√	√	√	√	√	√	√	√	√	√	√	√	√	√	√
P23	P23	Input	ADPC = 01 to 04H	x	1	x	x	x	x	√	√	√	√	√	√	√	√	√	√	√	√	
		Output	ADPC = 01 to 04H	x	0	0/1																
	ANI3	Analog input	ADPC = 00H/5H to 0FH	x	1	x	x	x	x	√	√	√	√	√	√	√	√	√	√	√	√	√
P24	P24	Input	ADPC = 01H to 05H	x	1	x	x	x	x	x	√	√	√	√	√	√	√	√	√	√	√	
		Output	ADPC = 01H to 05H	x	0	0/1																
	ANI4	Analog input	ADPC = 00H/06H to 0FH	x	1	x	x	x	x	x	√	√	√	√	√	√	√	√	√	√	√	√
P25	P25	Input	ADPC = 01H to 06H	x	1	x	x	x	x	x	√	√	√	√	√	√	√	√	√	√	√	
		Output	ADPC = 01H to 06H	x	0	0/1																
	ANI5	Analog input	ADPC = 00H/07H to 0FH	x	1	x	x	x	x	x	√	√	√	√	√	√	√	√	√	√	√	√
P26	P26	Input	ADPC = 01H to 07H	x	1	x	x	x	x	x	x	√	√	√	√	√	√	√	√	√	√	
		Output	ADPC = 01H to 07H	x	0	0/1																
	ANI6	Analog input	ADPC = 00H/08H to 0FH	x	1	x	x	x	x	x	x	√	√	√	√	√	√	√	√	√	√	√
P27	P27	Input	ADPC = 01H to 08H	x	1	x	x	x	x	x	x	x	√	√	√	√	√	√	√	√	√	
		Output	ADPC = 01H to 08H	x	0	0/1																
	ANI7	Analog input	ADPC = 00H/09H to 0FH	x	1	x	x	x	x	x	x	x	√	√	√	√	√	√	√	√	√	√

Table 4-7. Setting Examples of Registers and Output Latches When Using Alternate Function (7/21)

Pin Name	Used Function		PIORx ^{Note 1}	POMxx	PMCxx	PMxx	Pxx	Alternate Function Output		20-pin	24-pin	25-pin	30-pin	32-pin	36-pin	40-pin	44-pin	48-pin	52-pin	64-pin	80-pin	100-pin	128-pin		
	Function Name	I/O						SAU Output Function	Other than SAU																
P30	P30	Input	–	–	–	1	x	x	x																
		Output	–	–	–	0	0/1	SCK11/SCL11 = 1 ^{Note 2}	RTC1HZ = 0 ^{Note 3}	√	√	√	√	√	√	√	√	√	√	√	√	√	√	√	
	INTP3	Input	PIOR5 = 0 ^{Note 4}	–	–	1	x	x	x	√	√	√	√	√	√	√	√	√	√	√	√	√	√	√	
	RTC1HZ	Output	–	–	–	0	0	SCK11/SCL11 = 1 ^{Note 5}	x	x	x	x	x	x	√	√	√	√	√	√	√	√	√	√	
	SCK11	Input	–	–	–	1	x	x	x	√	√	√	√	√	√	√	√	√	√	√	√	√	√	√	x
		Output	–	–	–	0	1	x	RTC1HZ = 0 ^{Note 5}	√	√	√	√	√	√	√	√	√	√	√	√	√	√	√	x
	SCL11	Output	–	–	–	0	1	x	RTC1HZ = 0 ^{Note 5}	√	√	√	√	√	√	√	√	√	√	√	√	√	√	√	x
P31	P31	Input	–	–	–	1	x	–	x																
		Output	–	–	–	0	0/1	–	TO03 = 0, PLCBUZO = 0 ^{Note 6} , (PCLBUZO) = 0 ^{Note 7}	x	√	√	√	√	√	√	√	√	√	√	√	√	√	√	√
	TI03	Input	PIOR0 = 0	–	–	1	x	–	x	x	√	√	√	√	√	√	√	√	√	√	√	√	√	√	
	TO03	Output	PIOR0 = 0	–	–	0	0	–	PLCBUZO = 0 ^{Note 6} , (PCLBUZO) = 0 ^{Note 7}	x	√	√	√	√	√	√	√	√	√	√	√	√	√	√	√
	INTP4	Input	PIOR5 = 0 ^{Note 4}	–	–	1	x	–	x	x	√	√	√	√	√	√	√	√	√	√	√	√	√	√	
	PCLBUZO	Output	–	–	–	0	0	–	TO03 = 0	x	√	√	√	√	√	√	√	x	x	x	x	x	x	x	
	(PCLBUZO)	Output	PIOR3 = 1	–	–	0	0	–	TO03 = 0	x	x	x	x	x	x	x	x	x	√	√	√	√	√	√	
P32 to P34	P32 to P34	Input	–	–	–	1	x	–	–	x	x	x	x	x	x	x	x	x	x	x	x	x	x	√	
		Output	–	–	–	0	0/1	–	–																
P35 to P37	P35 to P37	Input	–	–	0	1	–	–	–	x	x	x	x	x	x	x	x	x	x	x	x	x	x	√	
		Output	–	–	0	0	0/1	–	–																
	ANI23 to ANI21	Analog input	–	–	1	1	x	–	–	x	x	x	x	x	x	x	x	x	x	x	x	x	x	√	

- Notes**
- 30- to 128-pin products only
 - 20- to 100-pin products only
 - 40- to 128-pin products only
 - 128-pin products only
 - 40- to 100-pin products only
 - 24- to 44-pin products only
 - 48- to 128-pin products only

Table 4-7. Setting Examples of Registers and Output Latches When Using Alternate Function (8/21)

Pin Name	Used Function		PIORx ^{Note 1}	POMxx	PMCxx	PMxx	Pxx	Alternate Function Output		20-pin	24-pin	25-pin	30-pin	32-pin	36-pin	40-pin	44-pin	48-pin	52-pin	64-pin	80-pin	100-pin	128-pin	
	Function Name	I/O						SAU Output Function	Other than SAU															
P40	P40	Input	–	–	–	1	x	–	–	√	√	√	√	√	√	√	√	√	√	√	√	√	√	√
		Output	–	–	–	0	0/1	–	–															
P41	P41	Input	–	–	–	1	x	–	x	x	x	x	x	x	x	x	√	√	√	√	√	√	√	√
		Output	–	–	–	0	0/1	–	TO07 = 0 ^{Note 2}															
	TI07	Input	PIOR0 = 0	–	–	1	x	–	x	x	x	x	x	x	x	x	√	√	√	√	√	x	x	
	TO07	Output	PIOR0 = 0	–	–	0	0	–	x	x	x	x	x	x	x	x	√	√	√	√	√	x	x	
P42	P42	Input	–	–	–	1	x	–	x	x	x	x	x	x	x	x	x	x	x	x	√	√	√	√
		Output	–	–	–	0	0/1	–	TO04 = 0															
	TI04	Input	PIOR0 = 0	–	–	1	x	–	x	x	x	x	x	x	x	x	x	x	x	x	√	√	√	√
	TO04	Output	PIOR0 = 0	–	–	0	0	–	x	x	x	x	x	x	x	x	x	x	x	x	√	√	√	√
P43	P43	Input	–	–	–	1	x	x	–															
		Output	–	0	–	0	0/1	SCK01/SCL01 = 0 ^{Note 3}	–	x	x	x	x	x	x	x	x	x	x	x	√	√	√	√
		N-ch open drain output	–	1	–	0	0/1		–															
	SCK01	Input	–	x	–	1	x	x	–	x	x	x	x	x	x	x	x	x	x	x	x	√	√	√
		Output	–	0/1	–	0	1	x	–	x	x	x	x	x	x	x	x	x	x	x	x	√	√	√
	SCL01	Output	–	0/1	–	0	1	x	–	x	x	x	x	x	x	x	x	x	x	x	x	√	√	√
P44	P44	Input	–	–	–	1	x	x	–															
		Output	–	0	–	0	0/1	SDA01 = 1	–	x	x	x	x	x	x	x	x	x	x	x	x	√	√	√
		N-ch open drain output	–	1	–	0	0/1		–															
	SI01	Input	–	x	–	1	x	x	–	x	x	x	x	x	x	x	x	x	x	x	x	√	√	√
	SDA01	I/O	–	1	–	0	1	x	–	x	x	x	x	x	x	x	x	x	x	x	x	√	√	√
P45	P45	Input	–	–	–	1	x	x	–															
		Output	–	0	–	0	0/1	SO01 = 1	–	x	x	x	x	x	x	x	x	x	x	x	x	√	√	√
		N-ch open drain output	–	1	–	0	0/1		–															
	SO01	Output	–	0/1	–	0	1	x	–	x	x	x	x	x	x	x	x	x	x	x	x	√	√	√

- Notes 1. 30- to 128-pin products only
2. 44- to 80-pin products only
3. 80- to 128-pin products only

Table 4-7. Setting Examples of Registers and Output Latches When Using Alternate Function (9/21)

Pin Name	Used Function		PIORx ^{Note 1}	POMxx	PMCxx	PMxx	Pxx	Alternate Function Output		20-pin	24-pin	25-pin	30-pin	32-pin	36-pin	40-pin	44-pin	48-pin	52-pin	64-pin	80-pin	100-pin	128-pin	
	Function Name	I/O						SAU Output Function	Other than SAU															
P46	P46	Input	–	–	–	1	x	–	x	x	x	x	x	x	x	x	x	x	x	x	x	x	√	√
		Output	–	–	–	0	0/1	–	–	–	–	–	–	–	–	–	–	–	–	–	–	–	–	–
	INTP1	Input	PIOR5 = 0	–	–	1	x	–	x	x	x	x	x	x	x	x	x	x	x	x	x	x	√	√
	TI05	Input	PIOR0 = 0	–	–	1	x	–	x	x	x	x	x	x	x	x	x	x	x	x	x	x	√	√
P47	P47	Input	–	–	–	1	x	–	–	x	x	x	x	x	x	x	x	x	x	x	x	x	√	√
		Output	–	–	–	0	0/1	–	–	x	x	x	x	x	x	x	x	x	x	x	x	x	√	√
	INTP2	Input	–	–	–	1	x	–	–	x	x	x	x	x	x	x	x	x	x	x	x	x	√	√
P50	P50	Input	–	–	–	1	x	x	–	x	√	√	√	√	√	√	√	√	√	√	√	√	√	√
		Output	–	0	–	0	0/1	–	–	x	√	√	√	√	√	√	√	√	√	√	√	√	√	√
		N-ch open drain output	–	1	–	0	0/1	SDA11 = 1 ^{Note 2}	–	x	√	√	√	√	√	√	√	√	√	√	√	√	√	√
	INTP1	Input	–	x	–	1	x	x	–	x	√	√	√	√	√	√	√	√	√	√	√	√	x	x
	SI11	Input	–	x	–	1	x	x	–	x	√	√	√	√	√	√	√	√	√	√	√	√	√	x
	SDA11	I/O	–	1	–	0	1	x	–	x	√	√	√	√	√	√	√	√	√	√	√	√	√	x
P51	P51	Input	–	–	–	1	x	x	–	x	x	x	√	√	√	√	√	√	√	√	√	√	√	√
		Output	–	–	–	0	0/1	SO01 = 1 ^{Note 3}	–	x	x	x	√	√	√	√	√	√	√	√	√	√	√	√
	INTP2	Input	–	–	–	1	x	x	–	x	x	x	√	√	√	√	√	√	√	√	√	√	x	x
	SO11	Output	–	–	–	0	1	x	–	x	x	x	√	√	√	√	√	√	√	√	√	√	√	x
P52	P52	Input	–	–	–	1	x	x	–	x	x	x	x	x	x	x	x	x	x	x	x	√	√	√
		Output	–	0	–	0	0/1	–	–	x	x	x	x	x	x	x	x	x	x	x	x	x	√	√
		N-ch open drain output	–	1	–	0	0/1	SO31 = 1 ^{Note 4}	–	x	x	x	x	x	x	x	x	x	x	x	x	x	x	√
	SO31	Output	–	0/1	–	0	1	x	–	x	x	x	x	x	x	x	x	x	x	x	x	√	√	√
	(INTP10)	Input	PIOR1 = 1	–	–	1	x	–	–	x	x	x	x	x	x	x	x	x	x	x	√	x	x	x

Notes 1. 30- to 128-pin products only

2. 24- to 100-pin products only

3. 30- to 100-pin products only

4. 80- to 128-pin products only

Table 4-7. Setting Examples of Registers and Output Latches When Using Alternate Function (10/21)

Pin Name	Used Function		PIORx	POMxx	PMCxx	PMxx	Pxx	Alternate Function Output		20-pin	24-pin	25-pin	30-pin	32-pin	36-pin	40-pin	44-pin	48-pin	52-pin	64-pin	80-pin	100-pin	128-pin	
	Function Name	I/O						SAU Output Function	Other than SAU															
P53	P53	Input	–	–	–	1	x	x	–															
		Output	–	0	–	0	0/1	SDA31 = 1 Note	–	x	x	x	x	x	x	x	x	x	x	x	√	√	√	√
		N-ch open drain output	–	1	–	0	0/1		–	x	x	x	x	x	x	x	x	x	x	x	x	x	x	x
	SI31	Input	–	x	–	1	x	x	–	x	x	x	x	x	x	x	x	x	x	x	x	√	√	√
	SDA31	I/O	–	1	–	0	1	x	–	x	x	x	x	x	x	x	x	x	x	x	x	√	√	√
	(INTP11)	Input	PIOR1 = 1	–	–	1	x	–	–	x	x	x	x	x	x	x	x	x	x	x	√	x	x	x
P54	P54	Input	–	–	–	1	x	x	–															
		Output	–	0	–	0	0/1	SCK31/SCL1 = 1 Note	–	x	x	x	x	x	x	x	x	x	x	x	√	√	√	√
		N-ch open drain output	–	1	–	0	0/1		–	x	x	x	x	x	x	x	x	x	x	x	x	x	x	x
	SCK31	Input	–	x	–	1	x	x	–	x	x	x	x	x	x	x	x	x	x	x	x	√	√	√
		Output	–	0/1	–	0	1	x	–	x	x	x	x	x	x	x	x	x	x	x	x	√	√	√
	SCL31	Output	–	0/1	–	0	1	x	–	x	x	x	x	x	x	x	x	x	x	x	x	√	√	√
P55	P55	Input	–	–	–	1	x	x	x															
		Output	–	0	–	0	0/1	(SCK00) = 1	(PCLBUZ1) = 0	x	x	x	x	x	x	x	x	x	x	x	√	√	√	√
		N-ch open drain output	–	1	–	0	0/1			x	x	x	x	x	x	x	x	x	x	x	x	√	√	√
	(PCLBUZ1)	Output	PIOR4 = 1	0	–	0	0	(SCK00) = 1	x	x	x	x	x	x	x	x	x	x	x	√	√	√	√	
	(SCK00)	Input	PIOR1 = 1	x	–	1	x	x	x	x	x	x	x	x	x	x	x	x	x	x	√	√	√	√
		Output	PIOR1 = 1	0/1	–	0	1	x	(PCLBUZ1) = 0	x	x	x	x	x	x	x	x	x	x	x	√	√	√	√
P56	P56	Input	–	–	–	1	x	–	–	x	x	x	x	x	x	x	x	x	x	x	x	√	√	
		Output	–	–	–	0	0/1	–	–	x	x	x	x	x	x	x	x	x	x	x	x	√	√	
	(INTP1)	Input	PIOR5 = 1	–	–	1	x	–	–	x	x	x	x	x	x	x	x	x	x	x	x	√	√	
P57	P57	Input	–	–	–	1	x	–	–	x	x	x	x	x	x	x	x	x	x	x	x	√	√	
		Output	–	–	–	0	0/1	–	–	x	x	x	x	x	x	x	x	x	x	x	x	√	√	
	(INTP3)	Input	PIOR5 = 1	–	–	1	x	–	–	x	x	x	x	x	x	x	x	x	x	x	x	√	√	

Note 80- to 128-pin products only

Table 4-7. Setting Examples of Registers and Output Latches When Using Alternate Function (11/21)

Pin Name	Used Function		PIORx Note 1	POMxx	PMCxx	PMxx	Pxx	Alternate Function Output		20-pin	24-pin	25-pin	30-pin	32-pin	36-pin	40-pin	44-pin	48-pin	52-pin	64-pin	80-pin	100-pin	128-pin	
	Function Name	I/O						SAU Output Function	Other than SAU															
P60	P60	Input	–	–	1	x	–	x	–	x	√	√	√	√	√	√	√	√	√	√	√	√	√	√
		N-ch open drain output (6-V tolerance)	–	–	0	0/1	–	SCLA0 = 0	x	√	√	√	√	√	√	√	√	√	√	√	√	√	√	√
	SCLA0	I/O	PIOR2 = 0	–	–	0	0	–	x	x	√	√	√	√	√	√	√	√	√	√	√	√	√	√
P61	P61	Input	–	–	1	x	–	x	–	x	√	√	√	√	√	√	√	√	√	√	√	√	√	√
		N-ch open drain output (6-V tolerance)	–	–	0	0/1	–	SDAA0 = 0	x	√	√	√	√	√	√	√	√	√	√	√	√	√	√	√
	SDAA0	I/O	PIOR2 = 0	–	–	0	0	–	x	x	√	√	√	√	√	√	√	√	√	√	√	√	√	√
P62	P62	Input	–	–	1	x	–	x	–	x	x	x	x	√	√	√	√	√	√	√	√	√	√	√
		N-ch open drain output (6-V tolerance)	–	–	0	0/1	–	SCLA1 = 0 Note 2	x	x	x	x	x	√	√	√	√	√	√	√	√	√	√	√
	SCLA1	I/O	–	–	0	0	–	x	x	x	x	x	x	x	x	x	x	x	x	x	√	√	√	√
P63	P63	Input	–	–	1	x	–	x	–	x	x	x	x	x	x	x	√	√	√	√	√	√	√	√
		N-ch open drain output (6-V tolerance)	–	–	0	0/1	–	SDAA1 = 0 Note 2	x	x	x	x	x	x	x	x	x	x	x	x	x	√	√	√
	SDAA1	I/O	–	–	0	0	–	x	x	x	x	x	x	x	x	x	x	x	x	x	√	√	√	√
P64	P64	Input	–	–	1	x	–	x	–	x	x	x	x	x	x	x	x	x	x	x	√	√	√	√
		Output	–	–	0	0/1	–	TO10 = 0	x	x	x	x	x	x	x	x	x	x	x	x	√	√	√	√
	TI10	Input	–	–	1	x	–	x	–	x	x	x	x	x	x	x	x	x	x	x	√	√	√	√
	TO10	Output	–	–	0	0	–	x	–	x	x	x	x	x	x	x	x	x	x	x	√	√	√	√
P65	P65	Input	–	–	1	x	–	x	–	x	x	x	x	x	x	x	x	x	x	x	√	√	√	√
		Output	–	–	0	0/1	–	TO11 = 0	x	x	x	x	x	x	x	x	x	x	x	x	√	√	√	√
	TI11	Input	–	–	1	x	–	x	–	x	x	x	x	x	x	x	x	x	x	x	√	√	√	√
	TO11	Output	–	–	0	0	–	x	–	x	x	x	x	x	x	x	x	x	x	x	√	√	√	√
P66	P66	Input	–	–	1	x	–	x	–	x	x	x	x	x	x	x	x	x	x	x	√	√	√	√
		Output	–	–	0	0/1	–	TO12 = 0	x	x	x	x	x	x	x	x	x	x	x	x	√	√	√	√
	TI12	Input	–	–	1	x	–	x	–	x	x	x	x	x	x	x	x	x	x	x	√	√	√	√
	TO12	Output	–	–	0	0	–	x	–	x	x	x	x	x	x	x	x	x	x	x	√	√	√	√

Notes 1. 30- to 128-pin products only

2. 80- to 128-pin products only

Table 4-7. Setting Examples of Registers and Output Latches When Using Alternate Function (12/21)

Pin Name	Used Function		PIORx	POMxx	PMCxx	PMxx	Pxx	Alternate Function Output		20-pin	24-pin	25-pin	30-pin	32-pin	36-pin	40-pin	44-pin	48-pin	52-pin	64-pin	80-pin	100-pin	128-pin	
	Function Name	I/O						SAU Output Function	Other than SAU															
P67	P67	Input	–	–	–	1	x	–	x	x	x	x	x	x	x	x	x	x	x	x	x	√	√	√
		Output	–	–	–	0	0/1	–	TO13 = 0	x	x	x	x	x	x	x	x	x	x	x	x	√	√	√
	TI13	Input	–	–	–	1	x	–	x	x	x	x	x	x	x	x	x	x	x	x	x	√	√	√
	TO13	Output	–	–	–	0	0	–	x	x	x	x	x	x	x	x	x	x	x	x	x	√	√	√
P70	P70	Input	–	–	–	1	x	x	–	x	x	x	x	√	√	√	√	√	√	√	√	√	√	√
		Output	–	–	–	0	0/1	SCK21/SCL21 = 1 Note 1	–	x	x	x	x	√	√	√	√	√	√	√	√	√	√	√
	KR0	Input	–	–	–	1	x	x	–	x	x	x	x	x	x	√	√	√	√	√	√	√	√	√
	SCK21	Input	–	–	–	1	x	x	–	x	x	x	x	x	√	√	√	√	√	√	√	√	√	√
		Output	–	–	–	0	1	x	–	x	x	x	x	x	√	√	√	√	√	√	√	√	√	√
	SCL21	Output	–	–	–	0	1	x	–	x	x	x	x	x	√	√	√	√	√	√	√	√	√	√
P71	P71	Input	–	–	–	1	x	x	–	x	x	x	x	x	x	√	√	√	√	√	√	√	√	√
		Output	–	0	–	0	0/1	SDA21 = 1	–	x	x	x	x	x	√	√	√	√	√	√	√	√	√	√
		N-ch open drain output	–	1	–	0	0/1	–	–	x	x	x	x	x	√	√	√	√	√	√	√	√	√	√
	KR1	Input	–	x	–	1	x	x	–	x	x	x	x	x	x	√	√	√	√	√	√	√	√	√
	SI21	Input	–	x	–	1	x	x	–	x	x	x	x	x	√	√	√	√	√	√	√	√	√	√
	SDA21	I/O	–	1	–	0	1	x	–	x	x	x	x	x	√	√	√	√	√	√	√	√	√	√
	P72	P72	Input	–	–	–	1	x	x	–	x	x	x	x	x	√	√	√	√	√	√	√	√	√
Output			–	–	–	0	0/1	SO21 = 1	–	x	x	x	x	x	√	√	√	√	√	√	√	√	√	√
KR2		Input	–	–	–	1	x	x	–	x	x	x	x	x	√	√	√	√	√	√	√	√	√	√
SO21		Output	–	–	–	0	1	x	–	x	x	x	x	x	√	√	√	√	√	√	√	√	√	√
P73	P73	Input	–	–	–	1	x	x	–	x	x	x	x	x	x	√	√	√	√	√	√	√	√	√
		Output	–	–	–	0	0/1	SO01 = 1 Note 2	–	x	x	x	x	x	x	√	√	√	√	√	√	√	√	√
	KR3	Input	–	–	–	1	x	x	–	x	x	x	x	x	√	√	√	√	√	√	√	√	√	√
	SO0	Output	–	–	–	0	1	x	–	x	x	x	x	x	x	x	x	√	√	√	x	x	x	x

- Notes 1. 36- to 128-pin products only
2. 48- to 164-pin products only

Table 4-7. Setting Examples of Registers and Output Latches When Using Alternate Function (13/21)

Pin Name	Used Function		PIORx	POMxx	PMCxx	PMxx	Pxx	Alternate Function Output		20-pin	24-pin	25-pin	30-pin	32-pin	36-pin	40-pin	44-pin	48-pin	52-pin	64-pin	80-pin	100-pin	128-pin		
	Function Name	I/O						SAU Output Function	Other than SAU																
P74	P74	Input	—	—	—	1	x	x	—																
		Output	—	0	—	0	0/1			x	x	x	x	x	x	x	x	x	√	√	√	√	√	√	√
		N-ch open drain output	—	1	—	0	0/1	SDA01 = 1 Note 1	—																
	KR4	Input	—	x	—	1	x	x	—	x	x	x	x	x	x	x	x	x	√	√	√	√	√	√	√
	INTP8	Input	PIOR5 = 0 Note 2	x	—	1	x	x	—	x	x	x	x	x	x	x	x	x	√	√	√	√	√	√	√
	SI01	Input	—	x	—	1	x	x	—	x	x	x	x	x	x	x	x	x	√	√	√	x	x	x	x
SDA01	I/O	—	1	—	0	1	x	—	x	x	x	x	x	x	x	x	x	√	√	√	x	x	x	x	
P75	P75	Input	—	—	—	1	x	x	—																
		Output	—	—	—	0	0/1	SCK01/SCL01 = 1 Note 1	—	x	x	x	x	x	x	x	x	x	√	√	√	√	√	√	√
	KR5	Input	—	—	—	1	x	x	—	x	x	x	x	x	x	x	x	√	√	√	√	√	√	√	
	INTP9	Input	PIOR5 = 0 Note 2	—	—	1	x	x	—	x	x	x	x	x	x	x	x	√	√	√	√	√	√	√	
	SCK01	Input	—	—	—	1	x	x	—	x	x	x	x	x	x	x	x	x	√	√	√	x	x	x	x
		Output	—	—	—	0	1	x	—	x	x	x	x	x	x	x	x	x	√	√	√	x	x	x	x
SCL01	Output	—	—	—	0	1	x	—	x	x	x	x	x	x	x	x	x	√	√	√	x	x	x	x	
P76	P76	Input	—	—	—	1	x	—	—	x	x	x	x	x	x	x	x	x	√	√	√	√	√	√	
		Output	—	—	—	0	0/1	—	—	x	x	x	x	x	x	x	x	x	√	√	√	√	√	√	
	KR6	Input	—	—	—	1	x	—	—	x	x	x	x	x	x	x	x	√	√	√	√	√	√	√	
	INTP10	Input	PIOR1 = 0	—	—	1	x	—	—	x	x	x	x	x	x	x	x	√	√	√	√	√	√	√	
	(Rx2)	Input	PIOR1 = 1	—	—	1	x	—	—	x	x	x	x	x	x	x	x	√	√	√	√	√	√	√	
P77	P77	Input	—	—	—	1	x	x	—	x	x	x	x	x	x	x	x	x	√	√	√	√	√	√	
		Output	—	—	—	0	0/1	(Tx2) = 1	—	x	x	x	x	x	x	x	x	x	√	√	√	√	√	√	
	KR7	Input	—	—	—	1	x	x	—	x	x	x	x	x	x	x	x	√	√	√	√	√	√	√	
	INTP11	Input	PIOR1 = 0	—	—	1	x	x	—	x	x	x	x	x	x	x	x	√	√	√	√	√	√	√	
	(Tx2)	Output	PIOR1 = 1	—	—	0	1	x	—	x	x	x	x	x	x	x	x	√	√	√	√	√	√	√	

- Notes 1. 48- to 64-pin products only
2. 100- and 128-pin products only

Table 4-7. Setting Examples of Registers and Output Latches When Using Alternate Function (14/21)

Pin Name	Used Function		PIORx	POMxx	PMCxx	PMxx	Pxx	Alternate Function Output		20-pin	24-pin	25-pin	30-pin	32-pin	36-pin	40-pin	44-pin	48-pin	52-pin	64-pin	80-pin	100-pin	128-pin	
	Function Name	I/O						SAU Output Function	Other than SAU															
P80	P80	Input	–	–	–	1	x	x	–															
		Output	–	0	–	0	0/1	(SCK10)/(SCL10) = 1	–	x	x	x	x	x	x	x	x	x	x	x	x	x	√	√
		N-ch open drain output	–	1	–	0	0/1		–															
	(SCK10)	Input	PIOR5 = 1	x	–	1	x	x	–	x	x	x	x	x	x	x	x	x	x	x	x	x	√	√
		Output	PIOR5 = 1	0/1	–	0	1	x	–	x	x	x	x	x	x	x	x	x	x	x	x	x	√	√
	(SCL10)	Output	PIOR5 = 1	0/1	–	0	1	x	–	x	x	x	x	x	x	x	x	x	x	x	x	x	√	√
P81	P81	Input	–	–	–	1	x	x	–															
		Output	–	0	–	0	0/1	(SDA10)= 1	–	x	x	x	x	x	x	x	x	x	x	x	x	x	√	√
		N-ch open drain output	–	1	–	0	0/1		–															
	(SI10)	Input	PIOR5 = 1	x	–	1	x	x	–	x	x	x	x	x	x	x	x	x	x	x	x	x	√	√
	(RxD1)	Input	PIOR5 = 1	x	–	1	x	x	–	x	x	x	x	x	x	x	x	x	x	x	x	x	√	√
	(SDA10)	Output	PIOR5 = 1	1	–	0	1	x	–	x	x	x	x	x	x	x	x	x	x	x	x	x	√	√
P82	P82	Input	–	–	–	1	x	x	–															
		Output	–	0	–	0	0/1	(SO10)/(TxD1) = 1	–	x	x	x	x	x	x	x	x	x	x	x	x	x	√	√
		N-ch open drain output	–	1	–	0	0/1		–															
	(SO10)	Output	PIOR5 = 1	0/1	–	0	1	x	–	x	x	x	x	x	x	x	x	x	x	x	x	√	√	
	(TxD1)	Output	PIOR5 = 1	0/1	–	0	1	x	–													√	√	
P83	P83	Input	–	–	–	1	x	–	–	x	x	x	x	x	x	x	x	x	x	x	x	√	√	
		Output	–	–	–	0	0/1	–	–															
P84	P84	Input	–	–	–	1	x	–	–	x	x	x	x	x	x	x	x	x	x	x	x	√	√	
		Output	–	–	–	0	0/1	–	–															
	(INTP6)	Input	PIOR5 = 1	–	–	1	x	–	–	x	x	x	x	x	x	x	x	x	x	x	x	√	√	
P85	P85	Input	–	–	–	1	x	–	–	x	x	x	x	x	x	x	x	x	x	x	x	√	√	
		Output	–	–	–	0	0/1	–	–															
	(INTP7)	Input	PIOR5 = 1	–	–	1	x	–	–	x	x	x	x	x	x	x	x	x	x	x	x	√	√	

Table 4-7. Setting Examples of Registers and Output Latches When Using Alternate Function (15/21)

Pin Name	Used Function		PIORx	POMxx	PMCxx	PMxx	Pxx	Alternate Function Output		20-pin	24-pin	25-pin	30-pin	32-pin	36-pin	40-pin	44-pin	48-pin	52-pin	64-pin	80-pin	100-pin	128-pin			
	Function Name	I/O						SAU Output Function	Other than SAU																	
P86	P86	Input	–	–	–	1	x	–	–	x	x	x	x	x	x	x	x	x	x	x	x	x	√	√		
		Output	–	–	–	0	0/1	–	–	x	x	x	x	x	x	x	x	x	x	x	x	x	x	√	√	
	(INTP8)	Input	PIOR5 = 1	–	–	1	x	–	–	x	x	x	x	x	x	x	x	x	x	x	x	x	x	√	√	
P87	P87	Input	–	–	–	1	x	–	–	x	x	x	x	x	x	x	x	x	x	x	x	x	x	√	√	
		Output	–	–	–	0	0/1	–	–	x	x	x	x	x	x	x	x	x	x	x	x	x	x	√	√	
	(INTP9)	Input	PIOR5 = 1	–	–	1	x	–	–	x	x	x	x	x	x	x	x	x	x	x	x	x	x	√	√	
P90 to P94	P90 to P94	Input	–	–	–	1	x	–	–	x	x	x	x	x	x	x	x	x	x	x	x	x	x	√	√	
		Output	–	–	–	0	0/1	–	–	x	x	x	x	x	x	x	x	x	x	x	x	x	x	√	√	
P95	P95	Input	–	–	–	1	x	x	–	x	x	x	x	x	x	x	x	x	x	x	x	x	x	√	√	
		Output	–	–	–	0	0/1	SCK11/SCL11 = 1	–	x	x	x	x	x	x	x	x	x	x	x	x	x	x	x	√	√
	SCK11	Input	–	–	–	1	x	x	–	x	x	x	x	x	x	x	x	x	x	x	x	x	x	x	√	√
		Output	–	–	–	0	1	x	–	x	x	x	x	x	x	x	x	x	x	x	x	x	x	x	√	√
	SCL11	Output	–	–	–	0	1	x	–	x	x	x	x	x	x	x	x	x	x	x	x	x	x	x	√	√
P96	P96	Input	–	–	–	1	x	x	–	x	x	x	x	x	x	x	x	x	x	x	x	x	x	√	√	
		Output	–	0	–	0	0/1	SDA11 = 1	–	x	x	x	x	x	x	x	x	x	x	x	x	x	x	x	√	√
		N-ch OD Output	–	1	–	0	0/1		–	x	x	x	x	x	x	x	x	x	x	x	x	x	x	x	√	√
	SI11	Input	–	x	–	1	x	x	–	x	x	x	x	x	x	x	x	x	x	x	x	x	x	x	√	√
	SDA11	I/O	–	1	–	0	1	x	–	x	x	x	x	x	x	x	x	x	x	x	x	x	x	x	√	√
P97	P97	Input	–	–	–	1	x	x	–	x	x	x	x	x	x	x	x	x	x	x	x	x	x	√	√	
		Output	–	–	–	0	0/1	SO11 = 1	–	x	x	x	x	x	x	x	x	x	x	x	x	x	x	x	√	√
	SO11	Output	–	–	–	0	1	x	–	x	x	x	x	x	x	x	x	x	x	x	x	x	x	x	√	√
P100	P100	Input	–	–	0	1	x	–	–	x	x	x	x	x	x	x	x	x	x	x	x	√	√	√	√	
		Output	–	–	0	0	0/1	–	–	x	x	x	x	x	x	x	x	x	x	x	x	x	√	√	√	√
	ANI20	Analog input	–	–	1	1	x	–	–	x	x	x	x	x	x	x	x	x	x	x	x	√	√	√	√	
P101	P101	Input	–	–	–	1	x	–	–	x	x	x	x	x	x	x	x	x	x	x	x	x	√	√	√	
		Output	–	–	–	0	0/1	–	–	x	x	x	x	x	x	x	x	x	x	x	x	x	√	√	√	

Table 4-7. Setting Examples of Registers and Output Latches When Using Alternate Function (16/21)

Pin Name	Used Function		PIORx	POMxx	PMCxx	PMxx	Pxx	Alternate Function Output		20-pin	24-pin	25-pin	30-pin	32-pin	36-pin	40-pin	44-pin	48-pin	52-pin	64-pin	80-pin	100-pin	128-pin				
	Function Name	I/O						SAU Output Function	Other than SAU																		
P102	P102	Input	—	—	—	1	x	—	x	x	x	x	x	x	x	x	x	x	x	x	x	x	√	√			
		Output	—	—	—	0	0/1	—	TO06 = 0	x	x	x	x	x	x	x	x	x	x	x	x	x	x	√	√		
	TI06	Input	PIOR0 = 0	—	—	1	x	—	x	x	x	x	x	x	x	x	x	x	x	x	x	x	x	√	√		
	TO06	Output	PIOR0 = 0	—	—	0	0	—	x	x	x	x	x	x	x	x	x	x	x	x	x	x	x	√	√		
P103	P103	Input	—	—	—	1	x	—	x	x	x	x	x	x	x	x	x	x	x	x	x	x	x	√	√		
		Output	—	—	—	0	0/1	—	TO14 = 0	x	x	x	x	x	x	x	x	x	x	x	x	x	x	x	√	√	
	TI14	Input	—	—	—	1	x	—	x	x	x	x	x	x	x	x	x	x	x	x	x	x	x	x	√	√	
	TO14	Output	—	—	—	0	0	—	x	x	x	x	x	x	x	x	x	x	x	x	x	x	x	x	√	√	
P104	P104	Input	—	—	—	1	x	—	x	x	x	x	x	x	x	x	x	x	x	x	x	x	x	x	√	√	
		Output	—	—	—	0	0/1	—	TO15 = 0	x	x	x	x	x	x	x	x	x	x	x	x	x	x	x	x	√	√
	TI15	Input	—	—	—	1	x	—	x	x	x	x	x	x	x	x	x	x	x	x	x	x	x	x	√	√	
	TO15	Output	—	—	—	0	0	—	x	x	x	x	x	x	x	x	x	x	x	x	x	x	x	x	√	√	
P105	P105	Input	—	—	—	1	x	—	x	x	x	x	x	x	x	x	x	x	x	x	x	x	x	x	√	√	
		Output	—	—	—	0	0/1	—	TO16 = 0	x	x	x	x	x	x	x	x	x	x	x	x	x	x	x	x	√	√
	TI16	Input	—	—	—	1	x	—	x	x	x	x	x	x	x	x	x	x	x	x	x	x	x	x	x	√	√
	TO16	Output	—	—	—	0	0	—	x	x	x	x	x	x	x	x	x	x	x	x	x	x	x	x	x	√	√
P106	P106	Input	—	—	—	1	x	—	x	x	x	x	x	x	x	x	x	x	x	x	x	x	x	x	x	√	√
		Output	—	—	—	0	0/1	—	TO17 = 0	x	x	x	x	x	x	x	x	x	x	x	x	x	x	x	x	x	√
	TI17	Input	—	—	—	1	x	—	x	x	x	x	x	x	x	x	x	x	x	x	x	x	x	x	x	√	√
	TO17	Output	—	—	—	0	0	—	x	x	x	x	x	x	x	x	x	x	x	x	x	x	x	x	x	√	√
P110	P110	Input	—	—	—	1	x	—	—	x	x	x	x	x	x	x	x	x	x	x	x	x	√	√	√	√	
		Output	—	—	—	0	0/1	—	—	x	x	x	x	x	x	x	x	x	x	x	x	x	√	√	√	√	
	(INTP10)	Input	PIOR1 = 1	—	—	1	x	—	—	x	x	x	x	x	x	x	x	x	x	x	x	√	√	√	√	√	
P111	P111	Input	—	—	—	1	x	—	—	x	x	x	x	x	x	x	x	x	x	x	x	x	√	√	√	√	
		Output	—	—	—	0	0/1	—	—	x	x	x	x	x	x	x	x	x	x	x	x	x	√	√	√	√	
	(INTP11)	Input	PIOR1 = 1	—	—	1	x	—	—	x	x	x	x	x	x	x	x	x	x	x	x	√	√	√	√	√	

Table 4-7. Setting Examples of Registers and Output Latches When Using Alternate Function (17/21)

Pin Name	Used Function		PIORx	POMxx	PMCxx	PMxx	Pxx	Alternate Function Output		20-pin	24-pin	25-pin	30-pin	32-pin	36-pin	40-pin	44-pin	48-pin	52-pin	64-pin	80-pin	100-pin	128-pin	
	Function Name	I/O						SAU Output Function	Other than SAU															
P112 to P114	P112 to P114	Input	–	–	–	1	x	–	–	x	x	x	x	x	x	x	x	x	x	x	x	x	x	√
		Output	–	–	–	0	0/1	–	–	x	x	x	x	x	x	x	x	x	x	x	x	x	x	√
P115 to P117	P115 to P117	Input	–	–	0	1	x	–	–	x	x	x	x	x	x	x	x	x	x	x	x	x	x	√
		Output	–	–	0	0	0/1	–	–	x	x	x	x	x	x	x	x	x	x	x	x	x	x	√
	ANI26 to ANI24	Analog input	–	–	1	1	x	–	–	x	x	x	x	x	x	x	x	x	x	x	x	x	x	√
P120	P120	Input	–	–	0	1	x	–	–	x	x	x	√	√	√	√	√	√	√	√	√	√	√	√
		Output	–	–	0	0	0/1	–	–	x	x	x	√	√	√	√	√	√	√	√	√	√	√	√
	ANI19	Analog input	–	–	1	1	x	–	–	x	x	x	√	√	√	√	√	√	√	√	√	√	√	√

Table 4-7. Setting Examples of Registers and Output Latches When Using Alternate Function (18/21)

Pin Name	Used Function		CMC (EXCLK, OSCSEL, EXCLKS, OSCSELS)	Pxx	20-pin	24-pin	25-pin	30-pin	32-pin	36-pin	40-pin	44-pin	48-pin	52-pin	64-pin	80-pin	100-pin	128-pin	
	Function Name	I/O																	
P121	P121	Input	00xx/10 xx/11 xx	x	√	√	√	√	√	√	√	√	√	√	√	√	√	√	√
	X1	–	01 xx	–	√	√	√	√	√	√	√	√	√	√	√	√	√	√	√
P122	P122	Input	00 xx/10 xx	x	√	√	√	√	√	√	√	√	√	√	√	√	√	√	√
	X2	–	01 xx	–	√	√	√	√	√	√	√	√	√	√	√	√	√	√	√
	EXCLK	Input	11 xx	–	√	√	√	√	√	√	√	√	√	√	√	√	√	√	√
P123	P123	Input	xx 00/xx 10/xx11	x	x	x	x	x	x	x	√	√	√	√	√	√	√	√	√
	XT1	–	xx 01	–	x	x	x	x	x	x	√	√	√	√	√	√	√	√	√
P124	P123	Input	xx 00/xx 10	x	x	x	x	x	x	x	√	√	√	√	√	√	√	√	√
	XT2	–	xx 01	–	x	x	x	x	x	x	√	√	√	√	√	√	√	√	√
	EXCLKS	Input	xx 11	–	x	x	x	x	x	x	√	√	√	√	√	√	√	√	√

Table 4-7. Setting Examples of Registers and Output Latches When Using Alternate Function (19/21)

Pin Name	Used Function		PIORx ^{Note 1}	POMxx	PMCxx	PMxx	Pxx	Alternate Function Output		20-pin	24-pin	25-pin	30-pin	32-pin	36-pin	40-pin	44-pin	48-pin	52-pin	64-pin	80-pin	100-pin	128-pin			
	Function Name	I/O						SAU Output Function	Other than SAU																	
P125 to P127	P125 to P127	Input	–	–	–	1	x	–	–	x	x	x	x	x	x	x	x	x	x	x	x	x	x	√		
		Output	–	–	–	0	0/1	–	–	–	–	–	–	–	–	–	–	–	–	–	–	–	–	–	–	
P130	P130	Output	–	–	–	–	0/1	–	–	x	x	√	x	x	x	x	x	√	√	√	√	√	√	√	√	
P137	P137	Input	–	–	–	–	x	–	–	√	√	√	√	√	√	√	√	√	√	√	√	√	√	√	√	
	INTP0	Input	–	–	–	–	x	–	–	√	√	√	√	√	√	√	√	√	√	√	√	√	√	√	√	
P140	P140	Input	–	–	–	1	x	–	x	x	x	x	x	x	x	x	x	√	√	√	√	√	√	√	√	
		Output	–	–	–	0	0/1	–	PCLBUZ0 = 0	x	x	x	x	x	x	x	x	x	√	√	√	√	√	√	√	
	PCLBUZ0	Output	PIOR3 = 0	–	–	0	0	–	x	x	x	x	x	x	x	x	x	√	√	√	√	√	√	√	√	
	INTP6	Input	PIOR5 = 0 ^{Note 2}	–	–	1	x	–	x	x	x	x	x	x	x	x	x	√	√	√	√	√	√	√	√	
P141	P141	Input	–	–	–	1	x	–	x	x	x	x	x	x	x	x	x	x	x	√	√	√	√	√	√	
		Output	–	–	–	0	0/1	–	PCLBUZ1 = 0	x	x	x	x	x	x	x	x	x	x	√	√	√	√	√	√	
	PCLBUZ1	Output	PIOR4 = 0	–	–	0	0	–	x	x	x	x	x	x	x	x	x	x	x	√	√	√	√	√	√	
P142	P142	Input	–	–	–	1	x	x	–	x	x	x	x	x	x	x	x	x	x	x	x	x	√	√	√	
		Output	–	0	–	0	0/1	SCK30/SCL30 = 1	–	x	x	x	x	x	x	x	x	x	x	x	x	x	√	√	√	
		N-ch open drain output	–	1	–	0	0/1	–	–	–	–	–	–	–	–	–	–	–	–	–	–	–	–	–	–	
	SCK30	Input	–	x	–	1	x	x	–	x	x	x	x	x	x	x	x	x	x	x	x	x	√	√	√	√
		Output	–	0/1	–	0	1	x	–	x	x	x	x	x	x	x	x	x	x	x	x	x	√	√	√	√
	SCL30	Output	–	0/1	–	0	1	x	–	x	x	x	x	x	x	x	x	x	x	x	x	x	√	√	√	√
P143	P143	Input	–	–	–	1	x	x	–	x	x	x	x	x	x	x	x	x	x	x	x	√	√	√	√	
		Output	–	0	–	0	0/1	SDA30 = 1	–	x	x	x	x	x	x	x	x	x	x	x	x	√	√	√	√	
		N-ch open drain output	–	1	–	0	0/1	–	–	–	–	–	–	–	–	–	–	–	–	–	–	–	–	–	–	
	SI30	Input	–	x	–	1	x	x	–	x	x	x	x	x	x	x	x	x	x	x	x	√	√	√	√	
	RxD3	Input	–	x	–	1	x	x	–	x	x	x	x	x	x	x	x	x	x	x	x	√	√	√	√	
	SDA30	I/O	–	1	–	0	1	x	–	x	x	x	x	x	x	x	x	x	x	x	x	√	√	√	√	

- Notes 1. 30- to 128-pin products only
2. 100- and 128-pin products only

Table 4-7. Setting Examples of Registers and Output Latches When Using Alternate Function (20/21)

Pin Name	Used Function		PIORx ^{Note}	POMxx	PMCxx	PMxx	Pxx	Alternate Function Output		20-pin	24-pin	25-pin	30-pin	32-pin	36-pin	40-pin	44-pin	48-pin	52-pin	64-pin	80-pin	100-pin	128-pin	
	Function Name	I/O						SAU Output Function	Other than SAU															
P144	P144	Input	–	–	–	1	x	x	–															
		Output	–	0	–	0	0/1		SO30/TxD3 = 1	–	x	x	x	x	x	x	x	x	x	x	x	√	√	√
		N-ch open drain output	–	1	–	0	0/1		–	–														
	SO30	Output	–	0/1	–	0	1	x	–	x	x	x	x	x	x	x	x	x	x	x	x	√	√	√
TxD3	Output	–	0/1	–	0	1	x	–	x	x	x	x	x	x	x	x	x	x	x	x	√	√	√	
P145	P145	Input	–	–	–	1	x	–	x	x	x	x	x	x	x	x	x	x	x	x	x	√	√	
		Output	–	–	–	0	0/1	–	TO07 = 0	x	x	x	x	x	x	x	x	x	x	x	x	√	√	
	TI07	Input	PIOR0 = 0	–	–	1	x	–	x	x	x	x	x	x	x	x	x	x	x	x	x	√	√	
	TO07	Output	PIOR0 = 0	–	–	0	0	–	x	x	x	x	x	x	x	x	x	x	x	x	x	√	√	
P146	P146	Input	–	–	–	1	x	–	–	x	x	x	x	x	x	x	√	√	√	√	√	√	√	
		Output	–	–	–	0	0/1	–	–	x	x	x	x	x	x	x	√	√	√	√	√	√	√	
	(INTP4)	Input	PIOR5 = 1	–	–	1	x	–	–	x	x	x	x	x	x	x	x	x	x	x	x	√	√	
P147	P147	Input	–	–	0	1	x	–	–	√	√	√	√	√	√	√	√	√	√	√	√	√	√	
		Output	–	–	0	0	0/1	–	–	√	√	√	√	√	√	√	√	√	√	√	√	√	√	
	ANI18	Analog input	–	–	1	1	x	–	–	√	√	√	√	√	√	√	√	√	√	√	√	√	√	

Note 30- to 128-pin products only

Table 4-7. Setting Examples of Registers and Output Latches When Using Alternate Function (21/21)

Pin Name	Used Function		ADPC	PMxx	Pxx	20-pin	24-pin	25-pin	30-pin	32-pin	36-pin	40-pin	44-pin	48-pin	52-pin	64-pin	80-pin	100-pin	128-pin		
	Function Name	I/O																			
P150	P150	Input	ADPC = 01H to 09H	1	x	x	x	x	x	x	x	x	x	x	x	x	x	√	√	√	
		Output	ADPC = 01H to 09H	0	0/1	x	x	x	x	x	x	x	x	x	x	x	x	x	√	√	√
	ANI8	Analog input	ADPC = 00H/0AH to 0FH	1	x	x	x	x	x	x	x	x	x	x	x	x	x	x	√	√	√
P151	P151	Input	ADPC = 01H to 0AH	1	x	x	x	x	x	x	x	x	x	x	x	x	x	x	√	√	√
		Output	ADPC = 01H to 0AH	0	0/1	x	x	x	x	x	x	x	x	x	x	x	x	x	√	√	√
	ANI9	Analog input	ADPC = 00H/0BH to 0FH	1	x	x	x	x	x	x	x	x	x	x	x	x	x	x	√	√	√
P152	P152	Input	ADPC = 01H to 0BH	1	x	x	x	x	x	x	x	x	x	x	x	x	x	x	√	√	√
		Output	ADPC = 01H to 0BH	0	0/1	x	x	x	x	x	x	x	x	x	x	x	x	x	√	√	√
	ANI10	Analog input	ADPC = 00H/0CH to 0FH	1	x	x	x	x	x	x	x	x	x	x	x	x	x	x	√	√	√
P153	P153	Input	ADPC = 01H to 0CH	1	x	x	x	x	x	x	x	x	x	x	x	x	x	x	√	√	√
		Output	ADPC = 01H to 0CH	0	0/1	x	x	x	x	x	x	x	x	x	x	x	x	x	√	√	√
	ANI11	Analog input	ADPC = 00H/0DH to 0FH	1	x	x	x	x	x	x	x	x	x	x	x	x	x	x	√	√	√
P154	P154	Input	ADPC = 01H to 0DH	1	x	x	x	x	x	x	x	x	x	x	x	x	x	x	√	√	√
		Output	ADPC = 01H to 0DH	0	0/1	x	x	x	x	x	x	x	x	x	x	x	x	x	√	√	√
	ANI12	Analog input	ADPC = 00H/0EH/0FH	1	x	x	x	x	x	x	x	x	x	x	x	x	x	x	√	√	√
P155	P155	Input	ADPC = 01H to 0EH	1	x	x	x	x	x	x	x	x	x	x	x	x	x	x	√	√	√
		Output	ADPC = 01H to 0EH	0	0/1	x	x	x	x	x	x	x	x	x	x	x	x	x	√	√	√
	ANI13	Analog input	ADPC = 00H/0FH	1	x	x	x	x	x	x	x	x	x	x	x	x	x	x	√	√	√
P156	P156	Input	ADPC = 01H to 0FH	1	x	x	x	x	x	x	x	x	x	x	x	x	x	x	√	√	√
		Output	ADPC = 01H to 0FH	0	0/1	x	x	x	x	x	x	x	x	x	x	x	x	x	√	√	√
	ANI14	Analog input	ADPC = 00H	1	x	x	x	x	x	x	x	x	x	x	x	x	x	x	√	√	√

4.6 Cautions When Using Port Function

4.6.1 Cautions on 1-Bit Manipulation Instruction for Port Register n (Pn)

When a 1-bit manipulation instruction is executed on a port that provides both input and output functions, the output latch value of an input port that is not subject to manipulation may be written in addition to the targeted bit.

Therefore, it is recommended to rewrite the output latch when switching a port from input mode to output mode.

<Example> When P10 is an output port, P11 to P17 are input ports (all pin statuses are high level), and the port latch value of port 1 is 00H, if the output of output port P10 is changed from low level to high level via a 1-bit manipulation instruction, the output latch value of port 1 is FFH.

Explanation: The targets of writing to and reading from the Pn register of a port whose PMnm bit is 1 are the output latch and pin status, respectively.

A 1-bit manipulation instruction is executed in the following order in the RL78/G13.

- <1> The Pn register is read in 8-bit units.
- <2> The targeted one bit is manipulated.
- <3> The Pn register is written in 8-bit units.

In step <1>, the output latch value (0) of P10, which is an output port, is read, while the pin statuses of P11 to P17, which are input ports, are read. If the pin statuses of P11 to P17 are high level at this time, the read value is FEH.

The value is changed to FFH by the manipulation in <2>.

FFH is written to the output latch by the manipulation in <3>.

Figure 4-11. Bit Manipulation Instruction (P10)

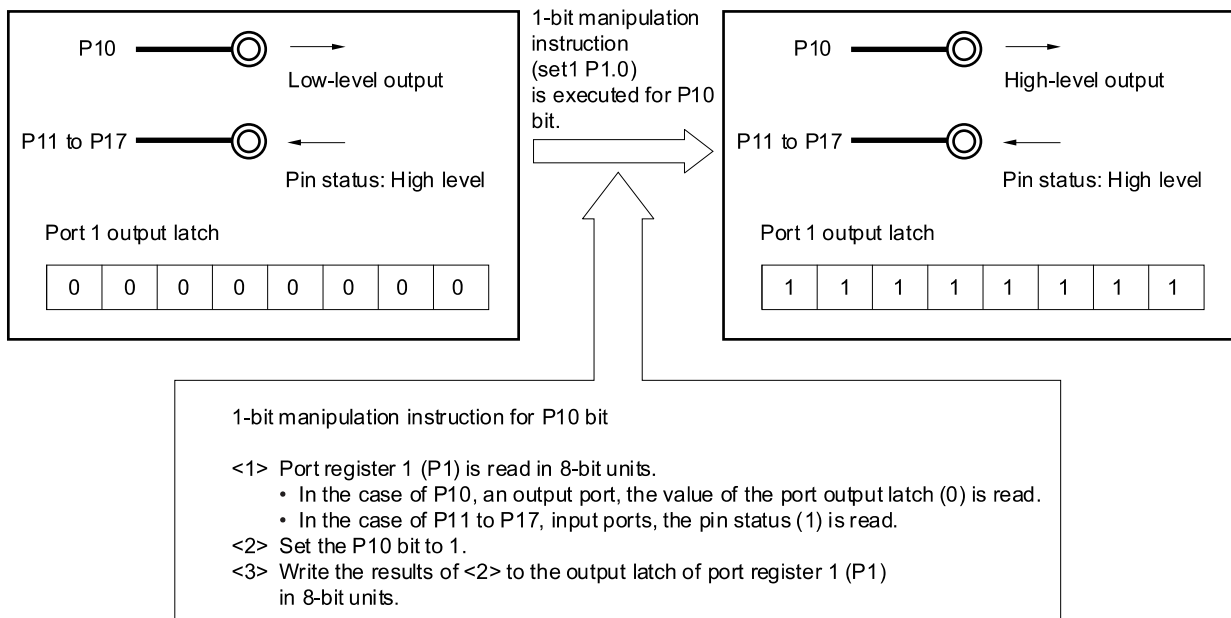

4.6.2 Notes on specifying the pin settings

For an output pin to which multiple functions are assigned, the output of the unused alternate functions must be set to its initial state so as to prevent conflicting outputs. This also applies to the functions assigned by using the peripheral I/O redirection register (PIOR). For details about the alternate function output, see **4.5 Register Settings When Using Alternate Function**.

No specific setting is required for input pins because the output of their alternate functions is disabled (the buffer output is Hi-Z).

Disabling the unused functions, including blocks that are only used for input or do not have I/O, is recommended for lower power consumption.

CHAPTER 5 CLOCK GENERATOR

The presence or absence of connecting resonator pin for main system clock, connecting resonator pin for subsystem clock, external clock input pin for main system clock, and external clock input pin for subsystem clock, depends on the product.

Output pin	20, 24, 25, 30, 32, 36-pin	40, 44, 48, 52, 64, 80, 100, 128-pin
X1 and X2 pins	√	√
EXCLK pin	√	√
XT1 and XT2 pins	–	√
EXCLKS pin	–	√

5.1 Functions of Clock Generator

The clock generator generates the clock to be supplied to the CPU and peripheral hardware. The following three kinds of system clocks and clock oscillators are selectable.

(1) Main system clock

<1> X1 oscillator

This circuit oscillates a clock of $f_x = 1$ to 20 MHz by connecting a resonator to X1 and X2 pins.

Oscillation can be stopped by executing the STOP instruction or setting of the MSTOP bit (bit 7 of the clock operation status control register (CSC)).

<2> High-speed on-chip oscillator

The frequency at which to oscillate can be selected from among $f_{IH} = 32, 24, 16, 12, 8, 4,$ or 1 MHz (typ.) by using the option byte (000C2H). After a reset release, the CPU always starts operating with this high-speed on-chip oscillator clock. Oscillation can be stopped by executing the STOP instruction or setting the HIOSTOP bit (bit 0 of the CSC register).

The frequency specified by using an option byte can be changed by using the high-speed on-chip oscillator frequency select register (HOCODIV). For details about the frequency, see **Figure 5-9 Format of High-speed On-chip Oscillator Frequency Select Register (HOCODIV)**.

The frequencies that can be specified for the high-speed on-chip oscillator by using the option byte and the high-speed on-chip oscillator frequency select register (HOCODIV) are shown below.

Power Supply Voltage	Oscillation Frequency (MHz)									
	1	2	3	4	6	8	12	16	24	32
$2.7\text{ V} \leq V_{DD} \leq 5.5\text{ V}$	√	√	√	√	√	√	√	√	√	√
$2.4\text{ V} \leq V_{DD} \leq 5.5\text{ V}$	√	√	√	√	√	√	√	√	–	–
$1.8\text{ V} \leq V_{DD} \leq 5.5\text{ V}$	√	√	√	√	√	√	–	–	–	–
$1.6\text{ V} \leq V_{DD} \leq 5.5\text{ V}$	√	√	√	√	–	–	–	–	–	–

An external main system clock ($f_{EX} = 1$ to 20 MHz) can also be supplied from the EXCLK/X2/P122 pin. An external main system clock input can be disabled by executing the STOP instruction or setting of the MSTOP bit.

As the main system clock, a high-speed system clock (X1 clock or external main system clock) or high-speed on-chip oscillator clock can be selected by setting of the MCM0 bit (bit 4 of the system clock control register (CKC)). However, note that the usable frequency range of the main system clock differs depending on the setting of the power supply voltage (VDD). The operating voltage of the flash memory must be set by using the CMODE0 and CMODE1 bits of the option byte (000C2H) (see **CHAPTER 24 OPTION BYTE**).

(2) Subsystem clock

• XT1 clock oscillator

This circuit oscillates a clock of $f_{XT} = 32.768$ kHz by connecting a 32.768 kHz resonator to XT1 and XT2 pins. Oscillation can be stopped by setting the XTSTOP bit (bit 6 of the clock operation status control register (CSC)).

An external subsystem clock ($f_{EXS} = 32.768$ KHz) can also be supplied from the EXCLKS/XT2/P124 pin. An external subsystem clock input can be disabled by the setting of the XTSTOP bit.

(3) Low-speed on-chip oscillator clock (Low-speed On-chip oscillator)

This circuit oscillates a clock of $f_{IL} = 15$ kHz (TYP.).

The low-speed on-chip oscillator clock cannot be used as the CPU clock.

Only the following peripheral hardware runs on the low-speed on-chip oscillator clock.

- Watchdog timer
- Real-time clock
- 12-bit Interval timer

This clock operates when bit 4 (WDTON) of the option byte (000C0H), bit 4 (WUTMMCK0) of the subsystem clock supply mode control register (OSMC), or both are set to 1.

However, when WDTON = 1, WUTMMCK0 = 0, and bit 0 (WDSTBYON) of the option byte (000C0H) is 0, oscillation of the low-speed on-chip oscillator stops if the HALT or STOP instruction is executed.

Caution The low-speed on-chip oscillator clock (f_{IL}) can only be selected as the real-time clock count clock when the fixed-cycle interrupt function is used.

Remark	f_x :	X1 clock oscillation frequency
	f_{IH} :	High-speed on-chip oscillator clock frequency
	f_{EX} :	External main system clock frequency
	f_{XT} :	XT1 clock oscillation frequency
	f_{EXS} :	External subsystem clock frequency
	f_{IL} :	Low-speed on-chip oscillator clock frequency

5.2 Configuration of Clock Generator

The clock generator includes the following hardware.

Table 5-1. Configuration of Clock Generator

Item	Configuration
Control registers	Clock operation mode control register (CMC) System clock control register (CKC) Clock operation status control register (CSC) Oscillation stabilization time counter status register (OSTC) Oscillation stabilization time select register (OSTS) Peripheral enable register 0 (PER0) Subsystem clock supply mode control register (OSMC) High-speed on-chip oscillator frequency select register (HOCODIV) High-speed on-chip oscillator trimming register (HIOTRM)
Oscillators	X1 oscillator XT1 oscillator High-speed on-chip oscillator Low-speed on-chip oscillator

Figure 5-1. Block Diagram of Clock Generator

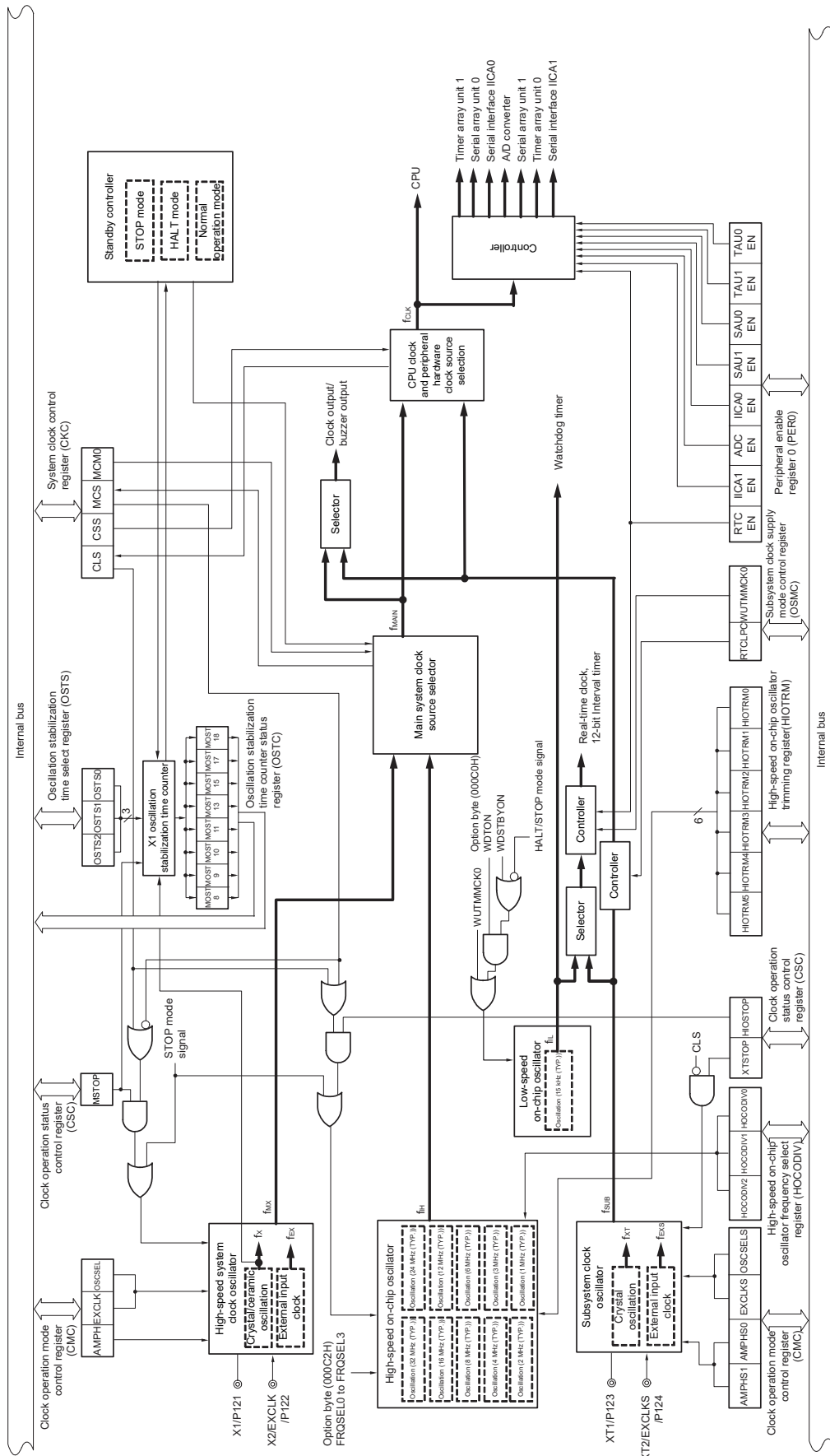

(Remark is listed on the next page.)

Remark	fx:	X1 clock oscillation frequency
	f_H:	High-speed on-chip oscillator clock frequency
	f_{EX}:	External main system clock frequency
	f_{MX}:	High-speed system clock frequency
	f_{MAIN}:	Main system clock frequency
	f_{XT}:	XT1 clock oscillation frequency
	f_{EXS}:	External subsystem clock frequency
	f_{SUB}:	Subsystem clock frequency
	f_{CLK}:	CPU/peripheral hardware clock frequency
	f_L:	Low-speed on-chip oscillator clock frequency

5.3 Registers Controlling Clock Generator

The following nine registers are used to control the clock generator.

- Clock operation mode control register (CMC)
- System clock control register (CKC)
- Clock operation status control register (CSC)
- Oscillation stabilization time counter status register (OSTC)
- Oscillation stabilization time select register (OSTS)
- Peripheral enable register 0 (PER0)
- Subsystem clock supply mode control register (OSMC)
- High-speed on-chip oscillator frequency select register (HOCODIV)
- High-speed on-chip oscillator trimming register (HIOTRM)

Caution Which registers and bits are included depends on the product. Be sure to set registers and bits that are not mounted in a product to their initial values.

5.3.1 Clock operation mode control register (CMC)

This register is used to set the operation mode of the X1/P121, X2/EXCLK/P122, XT1/P123, and XT2/EXCLKS/P124 pins, and to select a gain of the oscillator.

The CMC register can be written only once by an 8-bit memory manipulation instruction after reset release. This register can be read by an 8-bit memory manipulation instruction.

Reset signal generation clears this register to 00H.

Figure 5-2. Format of Clock Operation Mode Control Register (CMC)

Address: FFFA0H After reset: 00H R/W

Symbol	7	6	5	4	3	2	1	0
CMC	EXCLK	OSCSEL	EXCLKS	OSCSELS	0	AMPHS1	AMPHS0	AMPH

EXCLK	OSCSEL	High-speed system clock pin operation mode	X1/P121 pin	X2/EXCLK/P122 pin
0	0	Input port mode	Input port	
0	1	X1 oscillation mode	Crystal/ceramic resonator connection	
1	0	Input port mode	Input port	
1	1	External clock input mode	Input port	External clock input

EXCLKS	OSCSELS	Subsystem clock pin operation mode	XT1/P123 pin	XT2/EXCLKS/P124 pin
0	0	Input port mode	Input port	
0	1	XT1 oscillation mode	Crystal resonator connection	
1	0	Input port mode	Input port	
1	1	External clock input mode	Input port	External clock input

AMPHS1	AMPHS0	XT1 oscillator oscillation mode selection
0	0	Low power consumption oscillation (default)
0	1	Normal oscillation
1	0	Ultra-low power consumption oscillation
1	1	Setting prohibited

AMPH	Control of X1 clock oscillation frequency
0	1 MHz ≤ f _x ≤ 10 MHz
1	10 MHz < f _x ≤ 20 MHz

- Cautions**
1. The CMC register can be written only once after reset release, by an 8-bit memory manipulation instruction. When using the CMC register with its initial value (00H), be sure to set the register to 00H after a reset ends in order to prevent malfunction due to a program loop. Such a malfunction becomes unrecoverable when a value other than 00H is mistakenly written.
 2. After reset release, set the CMC register before X1 or XT1 oscillation is started as set by the clock operation status control register (CSC).
 3. Be sure to set the AMPH bit to 1 if the X1 clock oscillation frequency exceeds 10 MHz.
 4. Specify the settings for the AMPH, AMPHS1, and AMPHS0 bits while f_{ih} is selected as f_{clk} after a reset ends (before f_{clk} is switched to f_{mx} or f_{sub}).
 5. Oscillation stabilization time of f_{xt}, counting on the software.
 6. Although the maximum system clock frequency is 32 MHz, the maximum frequency of the X1 oscillator is 20 MHz.

(Cautions and Remark are given on the next page.)

Cautions 7. The XT1 oscillator is a circuit with low amplification in order to achieve low-power consumption. Note the following points when designing the circuit.

- Pins and circuit boards include parasitic capacitance. Therefore, perform oscillation evaluation using a circuit board to be actually used and confirm that there are no problems.
- Before using the ultra-low power consumption oscillation (AMPHS1, AMPHS0 = 1, 0) as the mode of the XT1 oscillator, evaluate the resonators described in 5.7 Resonator and Oscillator Constants.
- Make the wiring between the XT1 and XT2 pins and the resonators as short as possible, and minimize the parasitic capacitance and wiring resistance. Note this particularly when the ultra-low power consumption oscillation (AMPHS1, AMPHS0 = 1, 0) is selected.
- Configure the circuit of the circuit board, using material with little wiring resistance.
- Place a ground pattern that has the same potential as V_{SS} as much as possible near the XT1 oscillator.
- Be sure that the signal lines between the XT1 and XT2 pins, and the resonators do not cross with the other signal lines. Do not route the wiring near a signal line through which a high fluctuating current flows.
- The impedance between the XT1 and XT2 pins may drop and oscillation may be disturbed due to moisture absorption of the circuit board in a high-humidity environment or dew condensation on the board. When using the circuit board in such an environment, take measures to damp-proof the circuit board, such as by coating.
- When coating the circuit board, use material that does not cause capacitance or leakage between the XT1 and XT2 pins.

Remark fx: X1 clock frequency

5.3.2 System clock control register (CKC)

This register is used to select a CPU/peripheral hardware clock and a main system clock.

The CKC register can be set by a 1-bit or 8-bit memory manipulation instruction.

Reset signal generation sets this register to 00H.

Figure 5-3. Format of System Clock Control Register (CKC)

Address: FFFA4H After reset: 00H R/W^{Note 1}

Symbol	<7>	<6>	<5>	<4>	3	2	1	0
CKC	CLS	CSS	MCS	MCM0	0	0	0	0

CLS	Status of CPU/peripheral hardware clock (f _{CLK})
0	Main system clock (f _{MAIN})
1	Subsystem clock (f _{SUB})

CSS	Selection of CPU/peripheral hardware clock (f _{CLK})
0	Main system clock (f _{MAIN})
1 ^{Note 2}	Subsystem clock (f _{SUB})

MCS	Status of Main system clock (f _{MAIN})
0	High-speed on-chip oscillator clock (f _{IH})
1	High-speed system clock (f _{MX})

MCM0 ^{Note 2}	Main system clock (f _{MAIN}) operation control
0	Selects the high-speed on-chip oscillator clock (f _{IH}) as the main system clock (f _{MAIN})
1	Selects the high-speed system clock (f _{MX}) as the main system clock (f _{MAIN})

Notes 1. Bits 7 and 5 are read-only.

2. Changing the value of the MCM0 bit is prohibited while the CSS bit is set to 1.

Cautions 1. Be sure to set bit 3 to 0 to 0.

2. The clock set by the CSS bit is supplied to the CPU and peripheral hardware. If the CPU clock is changed, therefore, the clock supplied to peripheral hardware (except the real-time clock, 12-bit interval timer, clock output/buzzer output, and watchdog timer) is also changed at the same time. Consequently, stop each peripheral function when changing the CPU/peripheral hardware clock.

3. If the subsystem clock is used as the peripheral hardware clock, the operations of the A/D converter and IICA are not guaranteed. For the operating characteristics of the peripheral hardware, refer to the chapters describing the various peripheral hardware as well as CHAPTER 29 ELECTRICAL SPECIFICATIONS (T_A = -40 to +85°C) and CHAPTER 30 ELECTRICAL SPECIFICATIONS (G: INDUSTRIAL APPLICATIONS T_A = -40 to +105°C).

Remark f_{IH}: High-speed on-chip oscillator clock frequency
 f_{MX}: High-speed system clock frequency
 f_{MAIN}: Main system clock frequency
 f_{SUB}: Subsystem clock frequency

5.3.3 Clock operation status control register (CSC)

This register is used to control the operations of the high-speed system clock, high-speed on-chip oscillator clock, and subsystem clock (except the low-speed on-chip oscillator clock).

The CSC register can be set by a 1-bit or 8-bit memory manipulation instruction.

Reset signal generation sets this register to C0H.

Figure 5-4. Format of Clock Operation Status Control Register (CSC)

Address: FFFA1H After reset: C0H R/W

Symbol	<7>	<6>	5	4	3	2	1	<0>
CSC	MSTOP	XTSTOP	0	0	0	0	0	HIOSTOP

MSTOP	High-speed system clock operation control		
	X1 oscillation mode	External clock input mode	Input port mode
0	X1 oscillator operating	External clock from EXCLK pin is valid	Input port
1	X1 oscillator stopped	External clock from EXCLK pin is invalid	

XTSTOP	Subsystem clock operation control		
	XT1 oscillation mode	External clock input mode	Input port mode
0	XT1 oscillator operating	External clock from EXCLKS pin is valid	Input port
1	XT1 oscillator stopped	External clock from EXCLKS pin is invalid	

HIOSTOP	High-speed on-chip oscillator clock operation control
	0
1	High-speed on-chip oscillator stopped

- Cautions**
1. After reset release, set the clock operation mode control register (CMC) before setting the CSC register.
 2. Set the oscillation stabilization time select register (OSTS) before setting the MSTOP bit to 0 after releasing reset. Note that if the OSTS register is being used with its default settings, the OSTS register is not required to be set here.
 3. To start X1 oscillation as set by the MSTOP bit, check the oscillation stabilization time of the X1 clock by using the oscillation stabilization time counter status register (OSTC).
 4. When starting XT1 oscillation by setting the XSTOP bit, wait for oscillation of the subsystem clock to stabilize by setting a wait time using software.
 5. Do not stop the clock selected for the CPU peripheral hardware clock (f_{CLK}) with the OSC register.
 6. The setting of the flags of the register to stop clock oscillation (invalidate the external clock input) and the condition before clock oscillation is to be stopped are as Table 5-2.
Before stopping the clock oscillation, check the conditions before the clock oscillation is stopped.

Table 5-2. Stopping Clock Method

Clock	Condition Before Stopping Clock (Invalidating External Clock Input)	Setting of CSC Register Flags
X1 clock	CPU and peripheral hardware clocks operate with a clock other than the high-speed system clock. (CLS = 0 and MCS = 0, or CLS = 1)	MSTOP = 1
External main system clock		
XT1 clock	CPU and peripheral hardware clocks operate with a clock other than the subsystem clock. (CLS = 0)	XTSTOP = 1
External subsystem clock		
High-speed on-chip oscillator clock	CPU and peripheral hardware clocks operate with a clock other than the high-speed on-chip oscillator clock. (CLS = 0 and MCS = 1, or CLS = 1)	HIOSTOP = 1

5.3.4 Oscillation stabilization time counter status register (OSTC)

This is the register that indicates the count status of the X1 clock oscillation stabilization time counter.

The X1 clock oscillation stabilization time can be checked in the following case,

- If the X1 clock starts oscillation while the high-speed on-chip oscillator clock or subsystem clock is being used as the CPU clock.
- If the STOP mode is entered and then released while the high-speed on-chip oscillator clock is being used as the CPU clock with the X1 clock oscillating.

The OSTC register can be read by a 1-bit or 8-bit memory manipulation instruction.

When reset signal is generated, the STOP instruction and MSTOP (bit 7 of clock operation status control register (CSC)) = 1 clear the OSTC register to 00H.

Remark The oscillation stabilization time counter starts counting in the following cases.

- When oscillation of the X1 clock starts (EXCLK, OSCSEL = 0, 1 → MSTOP = 0)
- When the STOP mode is released

Figure 5-5. Format of Oscillation Stabilization Time Counter Status Register (OSTC)

Address: FFFA2H After reset: 00H R

Symbol	7	6	5	4	3	2	1	0
OSTC	MOST 8	MOST 9	MOST 10	MOST 11	MOST 13	MOST 15	MOST 17	MOST 18

MOST 8	MOST 9	MOST 10	MOST 11	MOST 13	MOST 15	MOST 17	MOST 18	Oscillation stabilization time status		
									$f_x = 10 \text{ MHz}$	$f_x = 20 \text{ MHz}$
0	0	0	0	0	0	0	0	$2^8/f_x \text{ max.}$	25.6 μs max.	12.8 μs max.
1	0	0	0	0	0	0	0	$2^8/f_x \text{ min.}$	25.6 μs min.	12.8 μs min.
1	1	0	0	0	0	0	0	$2^9/f_x \text{ min.}$	51.2 μs min.	25.6 μs min.
1	1	1	0	0	0	0	0	$2^{10}/f_x \text{ min.}$	102 μs min.	51.2 μs min.
1	1	1	1	0	0	0	0	$2^{11}/f_x \text{ min.}$	204 μs min.	102 μs min.
1	1	1	1	1	0	0	0	$2^{13}/f_x \text{ min.}$	819 μs min.	409 μs min.
1	1	1	1	1	1	0	0	$2^{15}/f_x \text{ min.}$	3.27 ms min.	1.63 ms min.
1	1	1	1	1	1	1	0	$2^{17}/f_x \text{ min.}$	13.1 ms min.	6.55 ms min.
1	1	1	1	1	1	1	1	$2^{18}/f_x \text{ min.}$	26.2 ms min.	13.1 ms min.

Cautions 1. After the above time has elapsed, the bits are set to 1 in order from the MOST8 bit and remain 1.

2. The oscillation stabilization time counter counts up to the oscillation stabilization time set by the oscillation stabilization time select register (OSTS).

In the following cases, set the oscillation stabilization time of the OSTs register to the value greater than the count value which is to be checked by the OSTC register.

- If the X1 clock starts oscillation while the high-speed on-chip oscillator clock or subsystem clock is being used as the CPU clock.
- If the STOP mode is entered and then released while the high-speed on-chip oscillator clock is being used as the CPU clock with the X1 clock oscillating.
(Note, therefore, that only the status up to the oscillation stabilization time set by the OSTs register is set to the OSTC register after the STOP mode is released.)

3. The X1 clock oscillation stabilization wait time does not include the time until clock oscillation starts (“a” below).

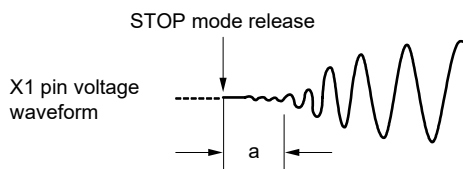

Remark f_x : X1 clock oscillation frequency

5.3.5 Oscillation stabilization time select register (OSTS)

This register is used to select the X1 clock oscillation stabilization wait time.

When the X1 clock is made to oscillate by clearing the MSTOP bit to start the X1 oscillation circuit operating, actual operation is automatically delayed for the time set in the OSTS register.

When switching the CPU clock from the high-speed on-chip oscillator clock or the subsystem clock to the X1 clock, and when using the high-speed on-chip oscillator clock for switching the X1 clock from the oscillating state to STOP mode, use the oscillation stabilization time counter status register (OSTC) to confirm that the desired oscillation stabilization time has elapsed after release from the STOP mode. That is, use the OSTC register to check that the oscillation stabilization time corresponding to its setting has been reached.

The OSTS register can be set by an 8-bit memory manipulation instruction.

Reset signal generation sets the OSTS register to 07H.

Figure 5-6. Format of Oscillation Stabilization Time Select Register (OSTS)

Address: FFFA3H After reset: 07H R/W

Symbol	7	6	5	4	3	2	1	0
OSTS	0	0	0	0	0	OSTS2	OSTS1	OSTS0

OSTS2	OSTS1	OSTS0	Oscillation stabilization time selection	Oscillation stabilization time selection	
				$f_x = 10 \text{ MHz}$	$f_x = 20 \text{ MHz}$
0	0	0	$2^8/f_x$	25.6 μs	12.8 μs
0	0	1	$2^9/f_x$	51.2 μs	25.6 μs
0	1	0	$2^{10}/f_x$	102 μs	51.2 μs
0	1	1	$2^{11}/f_x$	204 μs	102 μs
1	0	0	$2^{13}/f_x$	819 μs	409 μs
1	0	1	$2^{15}/f_x$	3.27 ms	1.63 ms
1	1	0	$2^{17}/f_x$	13.1 ms	6.55 ms
1	1	1	$2^{18}/f_x$	26.2 ms	13.1 ms

Cautions 1. Change the setting of the OSTS register before setting the MSTOP bit of the clock operation status control register (CSC) to 0.

2. The oscillation stabilization time counter counts up to the oscillation stabilization time set by the OSTS register.

In the following cases, set the oscillation stabilization time of the OSTS register to the value greater than the count value which is to be checked by the OSTC register after the oscillation starts.

- If the X1 clock starts oscillation while the high-speed on-chip oscillator clock or subsystem clock is being used as the CPU clock.
- If the STOP mode is entered and then released while the high-speed on-chip oscillator clock is being used as the CPU clock with the X1 clock oscillating. (Note, therefore, that only the status up to the oscillation stabilization time set by the OSTS register is set to the OSTC register after the STOP mode is released.)

3. The X1 clock oscillation stabilization wait time does not include the time until clock oscillation starts (“a” below).

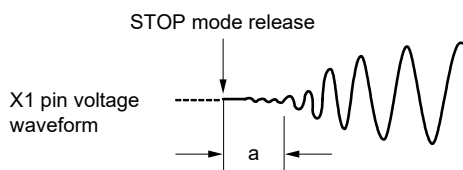

Remark f_x : X1 clock oscillation frequency

5.3.6 Peripheral enable register 0 (PER0)

These registers are used to enable or disable supplying the clock to the peripheral hardware. Clock supply to the hardware that is not used is also stopped so as to decrease the power consumption and noise.

To use the peripheral functions below, which are controlled by this register, set (1) the bit corresponding to each function before specifying the initial settings of the peripheral functions.

- Real-time clock, 12-bit interval timer
- Serial interface IICA1
- A/D converter
- Serial interface IICA0
- Serial array unit 1
- Serial array unit 0
- Timer array unit 1
- Timer array unit 0

The PER0 register can be set by a 1-bit or 8-bit memory manipulation instruction.

Reset signal generation clears these registers to 00H.

Figure 5-7. Format of Peripheral Enable Register 0 (PER0) (1/3)

Address: F00F0H After reset: 00H R/W

Symbol	<7>	<6>	<5>	<4>	<3>	<2>	<1>	<0>
PER0	RTCEN	IICA1EN	ADCEN	IICA0EN	SAU1EN	SAU0EN	TAU1EN	TAU0EN

RTCEN	Control of real-time clock (RTC) and 12-bit interval timer input clock supply
0	Stops input clock supply. <ul style="list-style-type: none"> • SFR used by the real-time clock (RTC) and 12-bit interval timer cannot be written. • The real-time clock (RTC) and 12-bit interval timer are in the reset status.
1	Enables input clock supply. <ul style="list-style-type: none"> • SFR used by the real-time clock (RTC) and 12-bit interval timer can be read and written.

IICA1EN	Control of serial interface IICA1 input clock supply
0	Stops input clock supply. <ul style="list-style-type: none"> • SFR used by the serial interface IICA1 cannot be written. • The serial interface IICA1 is in the reset status.
1	Enables input clock supply. <ul style="list-style-type: none"> • SFR used by the serial interface IICA1 can be read and written.

Caution Be sure to clear the following bits to 0.

20-pin products: bits 1, 3, 4, 6

24, 25-pin products: bits 1, 3, 6

30, 32, 36, 40, 44, 48, 52, 64-pin products: bits 1, 6

Figure 5-7. Format of Peripheral Enable Register 0 (PER0) (2/3)

Address: F00F0H After reset: 00H R/W

Symbol	<7>	<6>	<5>	<4>	<3>	<2>	<1>	<0>
PER0	RTCEN	IICA1EN	ADCEN	IICA0EN	SAU1EN	SAU0EN	TAU1EN	TAU0EN

ADCEN	Control of A/D converter input clock supply
0	Stops input clock supply. <ul style="list-style-type: none"> • SFR used by the A/D converter cannot be written. • The A/D converter is in the reset status.
1	Enables input clock supply. <ul style="list-style-type: none"> • SFR used by the A/D converter can be read and written.

IICA0EN	Control of serial interface IICA0 input clock supply
0	Stops input clock supply. <ul style="list-style-type: none"> • SFR used by the serial interface IICA0 cannot be written. • The serial interface IICA0 is in the reset status.
1	Enables input clock supply. <ul style="list-style-type: none"> • SFR used by the serial interface IICA0 can be read and written.

SAU1EN	Control of serial array unit 1 input clock supply
0	Stops input clock supply. <ul style="list-style-type: none"> • SFR used by the serial array unit 1 cannot be written. • The serial array unit 1 is in the reset status.
1	Enables input clock supply. <ul style="list-style-type: none"> • SFR used by the serial array unit 1 can be read and written.

SAU0EN	Control of serial array unit 0 input clock supply
0	Stops input clock supply. <ul style="list-style-type: none"> • SFR used by the serial array unit 0 cannot be written. • The serial array unit 0 is in the reset status.
1	Enables input clock supply. <ul style="list-style-type: none"> • SFR used by the serial array unit 0 can be read and written.

Caution Be sure to clear the following bits to 0.**20-pin products: bits 1, 3, 4, 6****24, 25-pin products: bits 1, 3, 6****30, 32, 36, 40, 44, 48, 52, 64-pin products: bits 1, 6**

Figure 5-7. Format of Peripheral Enable Register 0 (PER0) (3/3)

Address: F00F0H After reset: 00H R/W

Symbol	<7>	<6>	<5>	<4>	<3>	<2>	<1>	<0>
PER0	RTCEN	IICA1EN	ADCEN	IICA0EN	SAU1EN	SAU0EN	TAU1EN	TAU0EN

TAU1EN	Control of timer array unit 1 input clock supply
0	Stops input clock supply. <ul style="list-style-type: none"> • SFR used by timer array unit 1 cannot be written. • Timer array unit 1 is in the reset status.
1	Enables input clock supply. <ul style="list-style-type: none"> • SFR used by timer array unit 1 can be read and written.

TAU0EN	Control of timer array unit 0 input clock supply
0	Stops input clock supply. <ul style="list-style-type: none"> • SFR used by timer array unit 0 cannot be written. • Timer array unit 0 is in the reset status.
1	Enables input clock supply. <ul style="list-style-type: none"> • SFR used by timer array unit 0 can be read and written.

Caution Be sure to clear the following bits to 0.
20-pin products: bits 1, 3, 4, 6
24, 25-pin products: bits 1, 3, 6
30, 32, 36, 40, 44, 48, 52, 64-pin products: bits 1, 6

5.3.7 Subsystem clock supply mode control register (OSMC)

This register is used to reduce power consumption by stopping unnecessary clock functions.

If the RTCLPC bit is set to 1, power consumption can be reduced, because clock supply to the peripheral functions, except the real-time clock and 12-bit interval timer, is stopped in STOP mode or HALT mode while subsystem clock is selected as CPU clock.

In addition, the OSMC register can be used to select the count clock of the real-time clock and 12-bit interval timer.

The OSMC register can be set by an 8-bit memory manipulation instruction.

Reset signal generation clears this register to 00H.

Figure 5-8. Format of Subsystem Clock Supply Mode Control Register (OSMC)

Address: F00F3H After reset: 00H R/W

Symbol	7	6	5	4	3	2	1	0
OSMC	RTCLPC	0	0	WUTMMCK0	0	0	0	0

RTCLPC	Setting in STOP mode or HALT mode while subsystem clock is selected as CPU clock
0	Enables supply of subsystem clock to peripheral functions (See Tables 18-1, 18-2, and 18-3 for peripheral functions whose operations are enabled.)
1	Stops supply of subsystem clock to peripheral functions other than real-time clock and 12-bit interval timer.

WUTMMCK0	Selection of count clock for real-time clock and 12-bit interval timer
0	Subsystem clock (f_{SUB})
1	Low-speed on-chip oscillator clock (f_{L})

5.3.8 High-speed on-chip oscillator frequency select register (HOCODIV)

The frequency of the high-speed on-chip oscillator which is set by an option byte (000C2H) can be changed by using high-speed on-chip oscillator frequency select register (HOCODIV). However, the selectable frequency depends on the FRQSEL3 bit of the option byte (000C2H).

The HOCODIV register can be set by an 8-bit memory manipulation instruction.

Reset signal generation clears this register to the value set by FRQSEL2 to FRQSEL0 of the option byte (000C2H).

Figure 5-9. Format of High-speed On-chip Oscillator Frequency Select Register (HOCODIV)

Address: F00A8H After reset: the value set by FRQSEL2 to FRQSEL0 of the option byte (000C2H) R/W

Symbol	7	6	5	4	3	2	1	0
HOCODIV	0	0	0	0	0	HOCODIV2	HOCODIV1	HOCODIV0

HOCODIV2	HOCODIV1	HOCODIV0	High-Speed On-Chip Oscillator Clock Frequency	
			FRQSEL3 Bit is 0	FRQSEL3 Bit is 1
0	0	0	24 MHz	32 MHz
0	0	1	12 MHz	16 MHz
0	1	0	6 MHz	8 MHz
0	1	1	3 MHz	4 MHz
1	0	0	Setting prohibited	2 MHz
1	0	1	Setting prohibited	1 MHz
Other than above			Setting prohibited	

Cautions 1. Set the high-speed on-chip oscillator frequency select register (HOCODIV) within the operable voltage range of the flash operation mode set in the option byte (000C2H) before and after the frequency change.

Option Byte (000C2H) Value		Flash Operation Mode	Operating Frequency Range	Operating Voltage Range
CMODE1	CMODE2			
0	0	LV (low-voltage main) mode	1 MHz to 4 MHz	1.6 V to 5.5 V
1	0	LS (low-speed main) mode	1 MHz to 8 MHz	1.8 V to 5.5 V
1	1	HS (high-speed main) mode	1 MHz to 16 MHz	2.4 V to 5.5 V
			1 MHz to 32 MHz	2.7 V to 5.5 V

2. Set the HOCODIV register with the high-speed on-chip oscillator clock (f_{IH}) selected as the CPU/peripheral hardware clock (f_{CLK}).
3. After the frequency is changed with the HOCODIV register, the frequency is switched after the following transition time has elapsed.
 - Operation for up to three clocks at the pre-change frequency
 - CPU/peripheral hardware clock wait at the post-change frequency for up to three clocks

5.3.9 High-speed on-chip oscillator trimming register (HIOTRM)

This register is used to adjust the accuracy of the high-speed on-chip oscillator.

With self-measurement of the high-speed on-chip oscillator frequency via a timer using high-accuracy external clock input (timer array unit), and so on, the accuracy can be adjusted.

The HIOTRM register can be set by an 8-bit memory manipulation instruction.

Caution The frequency will vary if the temperature and V_{DD} pin voltage change after accuracy adjustment. When the temperature and V_{DD} voltage change, accuracy adjustment must be executed regularly or before the frequency accuracy is required.

Figure 5-10. Format of High-Speed On-Chip Oscillator Trimming Register (HIOTRM)

Address: F00A0H After reset: undefined ^{Note} R/W

Symbol	7	6	5	4	3	2	1	0
HIOTRM	0	0	HIOTRM5	HIOTRM4	HIOTRM3	HIOTRM2	HIOTRM1	HIOTRM0

HIOTRM5	HIOTRM4	HIOTRM3	HIOTRM2	HIOTRM1	HIOTRM0	High-speed on-chip oscillator
0	0	0	0	0	0	Minimum speed
0	0	0	0	0	1	↑
0	0	0	0	1	0	
0	0	0	0	1	1	
0	0	0	1	0	0	
• • •						
1	1	1	1	1	0	↓
1	1	1	1	1	1	

Note The value after reset is the value adjusted at shipment.

- Remarks**
1. The HIOTRM register holds a six-bit value used to adjust the high-speed on-chip oscillator with an increment of 1 corresponding to an increase of frequency by about 0.05%.
 2. For the usage example of the HIOTRM register, see the application note for RL78 MCU series High-speed On-chip Oscillator (HOCO) Clock Frequency Correction (R01AN0464).

5.4 System Clock Oscillator

5.4.1 X1 oscillator

The X1 oscillator oscillates with a crystal resonator or ceramic resonator (1 to 20 MHz) connected to the X1 and X2 pins.

An external clock can also be input. In this case, input the clock signal to the EXCLK pin.

To use the X1 oscillator, set bits 7 and 6 (EXCLK, OSCSEL) of the clock operation mode control register (CMC) as follows.

- Crystal or ceramic oscillation: EXCLK, OSCSEL = 0, 1
- External clock input: EXCLK, OSCSEL = 1, 1

When the X1 oscillator is not used, set the input port mode (EXCLK, OSCSEL = 0, 0).

When the pins are not used as input port pins, either, see **Table 2-3 Connections of Unused Pins**.

Figure 5-11 shows an example of the external circuit of the X1 oscillator.

Figure 5-11. Example of External Circuit of X1 Oscillator

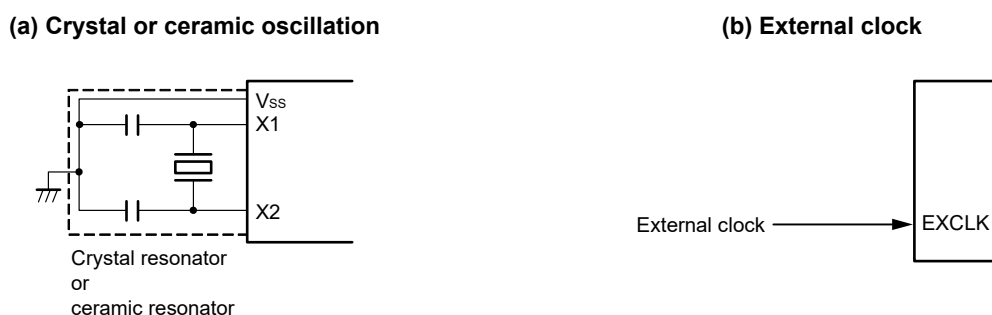

Cautions are listed on the next page.

5.4.2 XT1 oscillator

The XT1 oscillator oscillates with a crystal resonator (32.768 kHz (typ.) connected to the XT1 and XT2 pins.

To use the XT1 oscillator, set bit 4 (OSCSELS) of the clock operation mode control register (CMC) to 1.

An external clock can also be input. In this case, input the clock signal to the EXCLKS pin.

To use the XT1 oscillator, set bits 5 and 4 (EXCLKS, OSCSELS) of the clock operation mode control register (CMC) as follows.

- Crystal or ceramic oscillation: EXCLKS, OSCSELS = 0, 1
- External clock input: EXCLKS, OSCSELS = 1, 1

When the XT1 oscillator is not used, set the input port mode (EXCLKS, OSCSELS = 0, 0).

When the pins are not used as input port pins, either, see **Table 2-3 Connections of Unused Pins**.

Figure 5-12 shows an example of the external circuit of the XT1 oscillator.

Figure 5-12. Example of External Circuit of XT1 Oscillator



Caution When using the X1 oscillator and XT1 oscillator, wire as follows in the area enclosed by the broken lines in the Figures 5-11 and 5-12 to avoid an adverse effect from wiring capacitance.

- Keep the wiring length as short as possible.
- Do not cross the wiring with the other signal lines. Do not route the wiring near a signal line through which a high fluctuating current flows.
- Always make the ground point of the oscillator capacitor the same potential as V_{SS}. Do not ground the capacitor to a ground pattern through which a high current flows.
- Do not fetch signals from the oscillator.

The XT1 oscillator is a circuit with low amplification in order to achieve low-power consumption. Note the following points when designing the circuit.

- Pins and circuit boards include parasitic capacitance. Therefore, perform oscillation evaluation using a circuit board to be actually used and confirm that there are no problems.
- Before using the ultra-low power consumption oscillation (AMPHS1, AMPHS0 = 1, 0) as the mode of the XT1 oscillator, evaluate the resonators described in 5.7 Resonator and Oscillator Constants.
- Make the wiring between the XT1 and XT2 pins and the resonators as short as possible, and minimize the parasitic capacitance and wiring resistance. Note this particularly when the ultra-low power consumption oscillation (AMPHS1, AMPHS0 = 1, 0) is selected.
- Configure the circuit of the circuit board, using material with little wiring resistance.
- Place a ground pattern that has the same potential as V_{SS} as much as possible near the XT1 oscillator.
- Be sure that the signal lines between the XT1 and XT2 pins, and the resonators do not cross with the other signal lines. Do not route the wiring near a signal line through which a high fluctuating current flows.
- The impedance between the XT1 and XT2 pins may drop and oscillation may be disturbed due to moisture absorption of the circuit board in a high-humidity environment or dew condensation on the board. When using the circuit board in such an environment, take measures to damp-proof the circuit board, such as by coating.
- When coating the circuit board, use material that does not cause capacitance or leakage between the XT1 and XT2 pins.

Figure 5-13 shows examples of incorrect resonator connection.

Figure 5-13. Examples of Incorrect Resonator Connection (1/2)

(a) Too long wiring

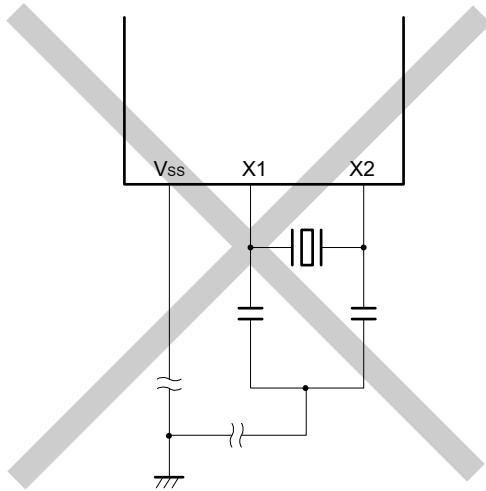

(b) Crossed signal line

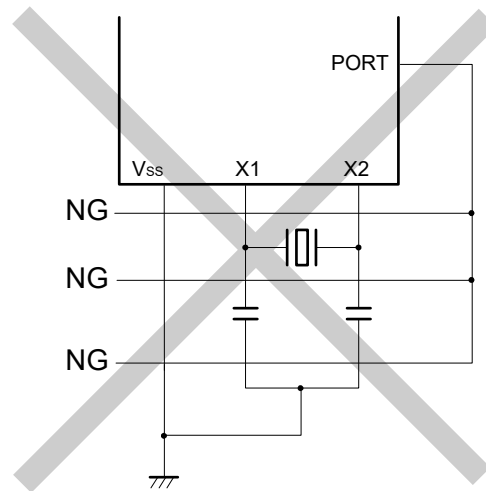

(c) The X1 and X2 signal line wires cross.

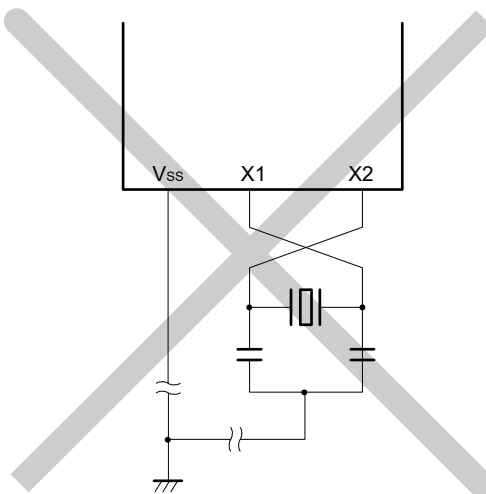

(d) A power supply/GND pattern exists under the X1 and X2 wires.

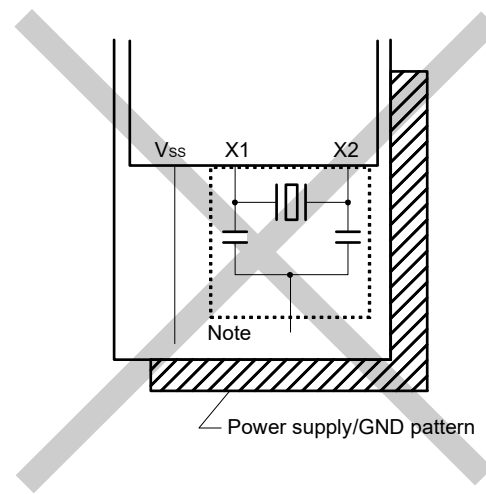

Note Do not place a power supply/GND pattern under the wiring section (section indicated by a broken line in the figure) of the X1 and X2 pins and the resonators in a multi-layer board or double-sided board. Do not configure a layout that will cause capacitance elements and affect the oscillation characteristics.

Remark When using the subsystem clock, replace X1 and X2 with XT1 and XT2, respectively.

Figure 5-13. Examples of Incorrect Resonator Connection (2/2)

(e) Wiring near high alternating current

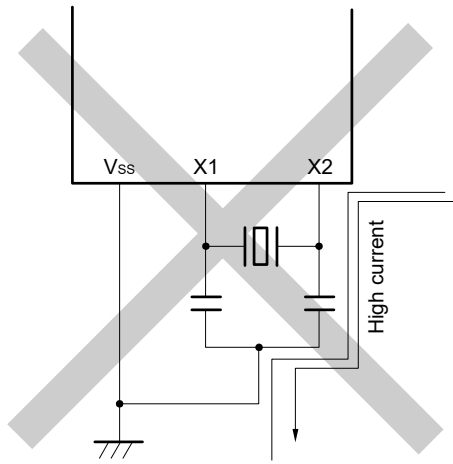

(f) Current flowing through ground line of oscillator (potential at points A, B, and C fluctuates)

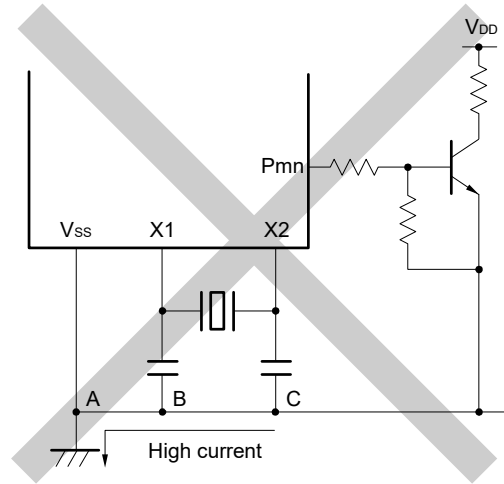

(g) Signals are fetched



Caution When X2 and XT1 pins are wired in parallel, the crosstalk noise of X2 pin may increase with XT1 pin, resulting in malfunctioning.

Remark When using the subsystem clock, replace X1 and X2 pins with XT1 and XT2 pins, respectively.

5.4.3 High-speed on-chip oscillator

The high-speed on-chip oscillator is incorporated in the RL78/G13. The frequency can be selected from among 32, 24, 16, 12, 8, 6, 4, 3, 2, or 1 MHz by using the option byte (000C2H). Oscillation can be controlled by bit 0 (HIOSTOP) of the clock operation status control register (CSC). The high-speed on-chip oscillator automatically starts oscillating after reset release.

5.4.4 Low-speed on-chip oscillator

The low-speed on-chip oscillator is incorporated in the RL78/G13.

The low-speed on-chip oscillator clock is used only as the watchdog timer, real-time clock, and 12-bit interval timer clock. The low-speed on-chip oscillator clock cannot be used as the CPU clock.

The low-speed on-chip oscillator runs while the watchdog timer is operating or when the setting of bit 4 (WUTMMCK0) in the subsystem clock supply mode control register (OSMC) is 1.

The low-speed on-chip oscillator is stopped when the watchdog timer is stopped and WUTMMCK0 is set to 0.

5.5 Clock Generator Operation

The clock generator generates the following clocks and controls the operation modes of the CPU, such as standby mode (see **Figure 5-1**).

- Main system clock f_{MAIN}
 - High-speed system clock f_{MX}
 - X1 clock f_{X}
 - External main system clock f_{EX}
 - High-speed on-chip oscillator clock f_{IH}
- Subsystem clock f_{SUB}
 - XT1 clock f_{XT}
 - External subsystem clock f_{EXS}
- Low-speed on-chip oscillator clock f_{IL}
- CPU/peripheral hardware clock f_{CLK}

The CPU starts operation when the high-speed on-chip oscillator starts outputting after a reset release in the RL78/G13. When the power supply voltage is turned on, the clock generator operation is shown in **Figure 5-14**.

Figure 5-14. Clock Generator Operation When Power Supply Voltage Is Turned On

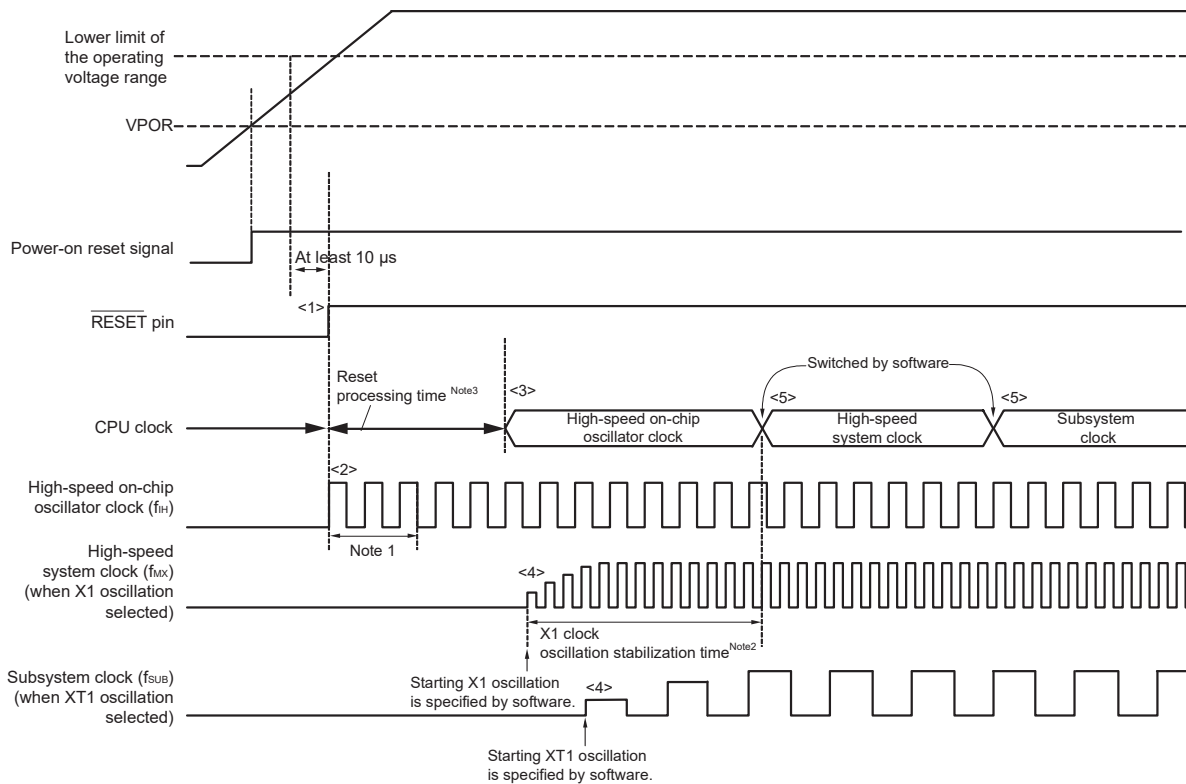

- <1> When the power is turned on, an internal reset signal is generated by the power-on-reset (POR) circuit. Note that the reset state is maintained after a reset by the voltage detection circuit or an external reset until the voltage reaches the range of operating voltage described in **29.4 AC Characteristics** and **30.4 AC Characteristics** (the above figure is an example when the external reset is in use).
- <2> When the reset is released, the high-speed on-chip oscillator automatically starts oscillation.
- <3> The CPU starts operation on the high-speed on-chip oscillator clock after waiting for the voltage to stabilize and a reset processing have been performed after reset release.
- <4> Set the start of oscillation of the X1 or XT1 clock via software (see **5.6.2 Example of setting X1 oscillation clock** and **5.6.3 Example of setting XT1 oscillation clock**).
- <5> When switching the CPU clock to the X1 or XT1 clock, wait for the clock oscillation to stabilize, and then set switching via software (see **5.6.2 Example of setting X1 oscillation clock** and **5.6.3 Example of setting XT1 oscillation clock**).

- Notes**
1. The reset processing time includes the oscillation accuracy stabilization time of the high-speed on-chip oscillator clock.
 2. When releasing a reset, confirm the oscillation stabilization time for the X1 clock using the oscillation stabilization time counter status register (OSTC).
 3. For the reset processing time, see **CHAPTER 20 POWER-ON-RESET CIRCUIT**.

Caution It is not necessary to wait for the oscillation stabilization time when an external clock input from the EXCLK pin is used.

5.6 Controlling Clock

5.6.1 Example of setting high-speed on-chip oscillator

After a reset release, the CPU/peripheral hardware clock (f_{CLK}) always starts operating with the high-speed on-chip oscillator clock. The frequency of the high-speed on-chip oscillator can be selected from 32, 24, 16, 12, 8, 6, 4, 3, 2, and 1 MHz by using FRQSEL0 to FRQSEL3 of the option byte (000C2H). The frequency can also be changed by the high-speed on-chip oscillator frequency select register (HOCODIV).

[Option byte setting]

Address: 000C2H

Option byte (000C2H)	7	6	5	4	3	2	1	0
	CMODE1	CMODE0			FRQSEL3	FRQSEL2	FRQSEL1	FRQSEL0
	0/1	0/1	1	0	0/1	0/1	0/1	0/1

CMODE1	CMODE0	Setting of flash operation mode	
0	0	LV (low voltage main) mode	$V_{DD} = 1.6\text{ V to }5.5\text{ V @ }1\text{ MHz to }4\text{ MHz}$
1	0	LS (low speed main) mode	$V_{DD} = 1.8\text{ V to }5.5\text{ V @ }1\text{ MHz to }8\text{ MHz}$
1	1	HS (high speed main) mode	$V_{DD} = 2.4\text{ V to }5.5\text{ V @ }1\text{ MHz to }16\text{ MHz}$ $V_{DD} = 2.7\text{ V to }5.5\text{ V @ }1\text{ MHz to }32\text{ MHz}$
Other than above		Setting prohibited	

FRQSEL3	FRQSEL2	FRQSEL1	FRQSEL0	Frequency of the high-speed on-chip oscillator
1	0	0	0	32 MHz
0	0	0	0	24 MHz
1	0	0	1	16 MHz
0	0	0	1	12 MHz
1	0	1	0	8 MHz
0	0	1	0	6 MHz
1	0	1	1	4 MHz
0	0	1	1	3 MHz
1	1	0	0	2 MHz
1	1	0	1	1 MHz
Other than above				Setting prohibited

[High-speed on-chip oscillator frequency select register (HOCODIV) setting]

Address: F00A8H

HOCODIV	7	6	5	4	3	2	1	0
	0	0	0	0	0	HOCODIV2	HOCODIV1	HOCODIV0

HOCODIV2	HOCODIV1	HOCODIV0	Selection of high-speed on-chip oscillator clock frequency	
			FRQSEL3 Bit is 0	FRQSEL3 Bit is 1
0	0	0	24 MHz	32 MHz
0	0	1	12 MHz	16 MHz
0	1	0	6 MHz	8 MHz
0	1	1	3 MHz	4 MHz
1	0	0	Setting prohibited	2 MHz
1	0	1	Setting prohibited	1 MHz
Other than above			Setting prohibited	

5.6.2 Example of setting X1 oscillation clock

After a reset release, the CPU/peripheral hardware clock (f_{CLK}) always starts operating with the high-speed on-chip oscillator clock. To subsequently change the clock to the X1 oscillation clock, set the oscillator and start oscillation by using the oscillation stabilization time select register (OSTS) and clock operation mode control register (CMC) and clock operation status control register (CSC) and wait for oscillation to stabilize by using the oscillation stabilization time counter status register (OSTC). After the oscillation stabilizes, set the X1 oscillation clock to f_{CLK} by using the system clock control register (CKC).

[Register settings] Set the register in the order of <1> to <5> below.

<1> Set (1) the OSCSEL bit of the CMC register, except for the cases where $f_x > 10$ MHz, in such cases set (1) the AMPH bit, to operate the X1 oscillator.

	7	6	5	4	3	2	1	0
CMC	EXCLK	OSCSEL	EXCLKS	OSCSELS		AMPHS1	AMPHS0	AMPH
	0	1	0	0	0	0	0	0/1

<2> Using the OSTS register, select the oscillation stabilization time of the X1 oscillator at releasing of the STOP mode.
Example: Setting values when a wait of at least 102 μ s is set based on a 10 MHz resonator.

	7	6	5	4	3	2	1	0
OSTS						OSTS2	OSTS1	OSTS0
	0	0	0	0	0	0	1	0

<3> Clear (0) the MSTOP bit of the CSC register to start oscillating the X1 oscillator.

	7	6	5	4	3	2	1	0
CSC	MSTOP	XTSTOP						HIOSTOP
	0	1	0	0	0	0	0	0

<4> Use the OSTC register to wait for oscillation of the X1 oscillator to stabilize.

Example: Wait until the bits reach the following values when a wait of at least 102 μ s is set based on a 10 MHz resonator.

	7	6	5	4	3	2	1	0
OSTC	MOST8	MOST9	MOST10	MOST11	MOST13	MOST15	MOST17	MOST18
	1	1	1	0	0	0	0	0

<5> Use the MCM0 bit of the CKC register to specify the X1 oscillation clock as the CPU/peripheral hardware clock.

	7	6	5	4	3	2	1	0
CKC	CLS	CSS	MCS	MCM0				
	0	0	0	1	0	0	0	0

Caution Keep the operating voltage within the range that allows operation of the flash memory as set in an option byte (000C2H) before and after changes to the main system clock (f_{MAIN}) by using the system clock control register (CKC).

Option Byte (000C2H) Value		Flash Operation Mode	Operating Frequency Range	Operating Voltage Range
CMODE1	CMODE2			
0	0	LV (low-voltage main) mode	1 MHz to 4 MHz	1.6 V to 5.5 V
1	0	LS (low-speed main) mode	1 MHz to 8 MHz	1.8 V to 5.5 V
1	1	HS (high-speed main) mode	1 MHz to 16 MHz	2.4 V to 5.5 V
			1 MHz to 32 MHz	2.7 V to 5.5 V

5.6.3 Example of setting XT1 oscillation clock

After a reset release, the CPU/peripheral hardware clock (f_{CLK}) always starts operating with the high-speed on-chip oscillator clock. To subsequently change the clock to the XT1 oscillation clock, set the oscillator and start oscillation by using the subsystem clock supply mode control register (OSMC), clock operation mode control register (CMC), and clock operation status control register (CSC), set the XT1 oscillation clock to f_{CLK} by using the system clock control register (CKC).

[Register settings] Set the register in the order of <1> to <5> below.

<1> To run only the real-time clock and 12-bit interval timer on the subsystem clock (ultra-low current consumption) when in the STOP mode or HALT mode during CPU operation on the subsystem clock, set the RTCLPC bit to 1.

	7	6	5	4	3	2	1	0
OSMC	RTCLPC			WUTMMCK0				
	0/1	0	0	0	0	0	0	0

<2> Set (1) the OSCSELS bit of the CMC register to operate the XT1 oscillator.

	7	6	5	4	3	2	1	0
CMC	EXCLK	OSCSEL	EXCLKS	OSCSELS		AMPHS1	AMPHS0	AMPH
	0	0	0	1	0	0/1	0/1	0

AMPHS0 and AMPHS1 bits: These bits are used to specify the oscillation mode of the XT1 oscillator.

<3> Clear (0) the XTSTOP bit of the CSC register to start oscillating the XT1 oscillator.

	7	6	5	4	3	2	1	0
CSC	MSTOP	XTSTOP						HIOSTOP
	1	0	0	0	0	0	0	0

<4> Use the timer function or another function to wait for oscillation of the subsystem clock to stabilize by using software.

<5> Use the CSS bit of the CKC register to specify the XT1 oscillation clock as the CPU/peripheral hardware clock.

	7	6	5	4	3	2	1	0
CKC	CLS	CSS	MCS	MCM0				
	0	1	0	0	0	0	0	0

5.6.4 CPU clock status transition diagram

Figure 5-15 shows the CPU clock status transition diagram of this product.

Figure 5-15. CPU Clock Status Transition Diagram

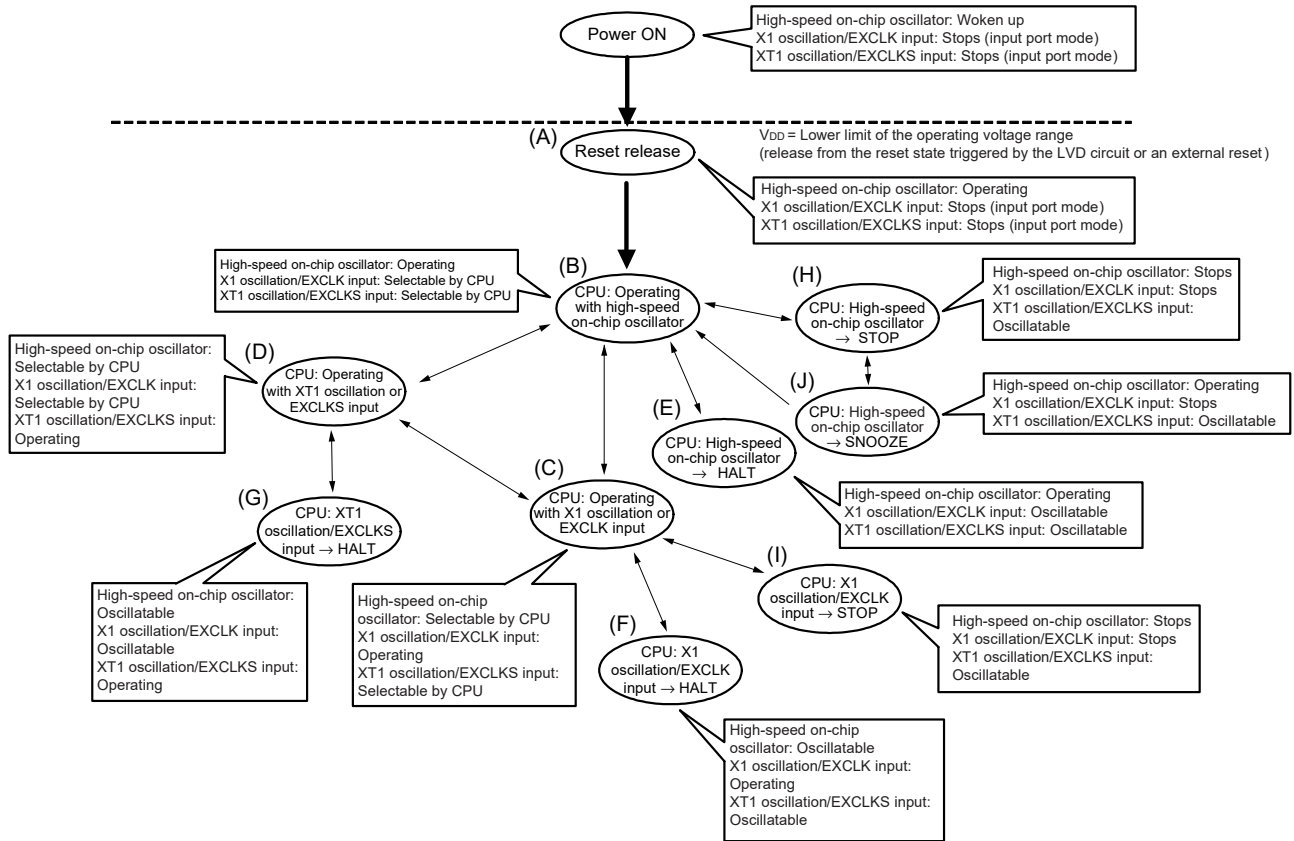

Table 5-3 shows transition of the CPU clock and examples of setting the SFR registers.

Table 5-3. CPU Clock Transition and SFR Register Setting Examples (1/5)

(1) CPU operating with high-speed on-chip oscillator clock (B) after reset release (A)

Status Transition	SFR Register Setting
(A) → (B)	SFR registers do not have to be set (default status after reset release).

(2) CPU operating with high-speed system clock (C) after reset release (A)

(The CPU operates with the high-speed on-chip oscillator clock immediately after a reset release (B).)

(Setting sequence of SFR registers) →

Setting Flag of SFR Register Status Transition	CMC Register ^{Note 1}			OSTS Register	CSC Register MSTOP	OSTC Register	CKC Register MCM0
	EXCLK	OSCSEL	AMPH				
(A) → (B) → (C) (X1 clock: 1 MHz ≤ f _x ≤ 10 MHz)	0	1	0	Note 2	0	Must be checked	1
(A) → (B) → (C) (X1 clock: 10 MHz < f _x ≤ 20 MHz)	0	1	1	Note 2	0	Must be checked	1
(A) → (B) → (C) (external main clock)	1	1	×	Note 2	0	Must not be checked	1

Notes 1. The clock operation mode control register (CMC) can be written only once by an 8-bit memory manipulation instruction after reset release.

2. Set the oscillation stabilization time as follows.

- Desired the oscillation stabilization time counter status register (OSTC) oscillation stabilization time ≤ Oscillation stabilization time set by the oscillation stabilization time select register (OSTS)

Caution Set the clock after the supply voltage has reached the operable voltage of the clock to be set (see CHAPTER 29 ELECTRICAL SPECIFICATIONS (T_A = -40 to +85°C) and CHAPTER 30 ELECTRICAL SPECIFICATIONS (G: INDUSTRIAL APPLICATIONS T_A = -40 to +105°C)).

(3) CPU operating with subsystem clock (D) after reset release (A)

(The CPU operates with the high-speed on-chip oscillator clock immediately after a reset release (B).)

(Setting sequence of SFR registers) →

Setting Flag of SFR Register Status Transition	CMC Register ^{Note}				CSC Register XTSTOP	Waiting for Oscillation Stabilization	CKC Register CSS
	EXCLKS	OSCSELS	AMPHS1	AMPHS0			
(A) → (B) → (D) (XT1 clock)	0	1	0/1	0/1	0	Necessary	1
(A) → (B) → (D) (external sub clock)	1	1	×	×	0	Necessary	1

Note The clock operation mode control register (CMC) can be written only once by an 8-bit memory manipulation instruction after reset release.

Remarks 1. ×: don't care

2. (A) to (J) in Table 5-3 correspond to (A) to (J) in Figure 5-15.

Table 5-3. CPU Clock Transition and SFR Register Setting Examples (2/5)

(4) CPU clock changing from high-speed on-chip oscillator clock (B) to high-speed system clock (C)

(Setting sequence of SFR registers) →

Setting Flag of SFR Register Status Transition	CMC Register ^{Note 1}			OSTS Register	CSC Register MSTOP	OSTC Register	CKC Register MCM0
	EXCLK	OSCSEL	AMPH				
(B) → (C) (X1 clock: 1 MHz ≤ f _x ≤ 10 MHz)	0	1	0	Note 2	0	Must be checked	1
(B) → (C) (X1 clock: 10 MHz < f _x ≤ 20 MHz)	0	1	1	Note 2	0	Must be checked	1
(B) → (C) (external main clock)	1	1	×	Note 2	0	Must not be checked	1

Unnecessary if these registers are already set Unnecessary if the CPU is operating with the high-speed system clock

- Notes**
- The clock operation mode control register (CMC) can be written only once by an 8-bit memory manipulation instruction after reset release. This setting is not necessary if it has already been set.
 - Set the oscillation stabilization time as follows.
 - Desired the oscillation stabilization time counter status register (OSTC) oscillation stabilization time ≤ Oscillation stabilization time set by the oscillation stabilization time select register (OSTS)

Caution Set the clock after the supply voltage has reached the operable voltage of the clock to be set (see CHAPTER 29 ELECTRICAL SPECIFICATIONS (T_A = -40 to +85°C) and CHAPTER 30 ELECTRICAL SPECIFICATIONS (G: INDUSTRIAL APPLICATIONS T_A = -40 to +105°C)).

(5) CPU clock changing from high-speed on-chip oscillator clock (B) to subsystem clock (D)

(Setting sequence of SFR registers) →

Setting Flag of SFR Register Status Transition	CMC Register ^{Note}			CSC Register XTSTOP	Waiting for Oscillation Stabilization	CKC Register CSS
	EXCLKS	OSCSELS	AMPHS1,0			
(B) → (D) (XT1 clock)	0	1	00: Low power consumption oscillation 01: Normal oscillation 10: Ultra-low power consumption oscillation	0	Necessary	1
(B) → (D) (external sub clock)	1	1	×	0	Necessary	1

Unnecessary if these registers are already set Unnecessary if the CPU is operating with the subsystem clock

Note The clock operation mode control register (CMC) can be written only once by an 8-bit memory manipulation instruction after reset release. This setting is not necessary if it has already been set.

- Remarks**
- ×: don't care
 - (A) to (J) in Table 5-3 correspond to (A) to (J) in Figure 5-15.

Table 5-3. CPU Clock Transition and SFR Register Setting Examples (3/5)

(6) CPU clock changing from high-speed system clock (C) to high-speed on-chip oscillator clock (B)

(Setting sequence of SFR registers) ▶

Setting Flag of SFR Register	CSC Register	Oscillation accuracy stabilization time	CKC Register
	HIOSTOP		MCM0
Status Transition			
(C) → (B)	0	18 μs to 65 μs	0

Unnecessary if the CPU is operating with the high-speed on-chip oscillator clock

Remark The oscillation accuracy stabilization time changes according to the temperature conditions and the STOP mode period.

(7) CPU clock changing from high-speed system clock (C) to subsystem clock (D)

(Setting sequence of SFR registers) ▶

Setting Flag of SFR Register	CSC Register	Waiting for Oscillation Stabilization	CKC Register
	XTSTOP		CSS
Status Transition			
(C) → (D)	0	Necessary	1

Unnecessary if the CPU is operating with the subsystem clock

(8) CPU clock changing from subsystem clock (D) to high-speed on-chip oscillator clock (B)

(Setting sequence of SFR registers) ▶

Setting Flag of SFR Register	CSC Register	Oscillation accuracy stabilization time	CKC Register
	HIOSTOP		CSS
Status Transition			
(D) → (B)	0	18 μs to 65 μs	0

Unnecessary if the CPU is operating with the high-speed on-chip oscillator clock

Remarks 1. (A) to (J) in Table 5-3 correspond to (A) to (J) in Figure 5-15.
 2. The oscillation accuracy stabilization time changes according to the temperature conditions and the STOP mode period.

Table 5-3. CPU Clock Transition and SFR Register Setting Examples (4/5)

(9) CPU clock changing from subsystem clock (D) to high-speed system clock (C)

(Setting sequence of SFR registers) →

Setting Flag of SFR Register Status Transition	OSTS Register	CSC Register	OSTC Register	CKC Register
		MSTOP		CSS
(D) → (C) (X1 clock: 1 MHz ≤ f _x ≤ 10 MHz)	Note	0	Must be checked	0
(D) → (C) (X1 clock: 10 MHz < f _x ≤ 20 MHz)	Note	0	Must be checked	0
(D) → (C) (external main clock)	Note	0	Must not be checked	0

Unnecessary if the CPU is operating with the high-speed system clock

Note Set the oscillation stabilization time as follows.

- Desired the oscillation stabilization time counter status register (OSTC) oscillation stabilization time ≤ Oscillation stabilization time set by the oscillation stabilization time select register (OSTS)

Caution Set the clock after the supply voltage has reached the operable voltage of the clock to be set (see CHAPTER 29 ELECTRICAL SPECIFICATIONS (T_A = -40 to +85°C) and CHAPTER 30 ELECTRICAL SPECIFICATIONS (G: INDUSTRIAL APPLICATIONS T_A = -40 to +105°C)).

(10) • HALT mode (E) set while CPU is operating with high-speed on-chip oscillator clock (B)

- HALT mode (F) set while CPU is operating with high-speed system clock (C)
- HALT mode (G) set while CPU is operating with subsystem clock (D)

Status Transition	Setting
(B) → (E) (C) → (F) (D) → (G)	Executing HALT instruction

Remark (A) to (J) in Table 5-3 correspond to (A) to (J) in Figure 5-15.

Table 5-3. CPU Clock Transition and SFR Register Setting Examples (5/5)

- (11) • **STOP mode (H) set while CPU is operating with high-speed on-chip oscillator clock (B)**
- **STOP mode (I) set while CPU is operating with high-speed system clock (C)**

(Setting sequence) →

Status Transition		Setting		
(B) → (H)		Stopping peripheral functions that are disabled in STOP mode	–	Executing STOP instruction
(C) → (I)	In X1 oscillation		Sets the OSTS register	
	External main system clock		–	

(12) CPU changing from STOP mode (H) to SNOOZE mode (J)

For details about the setting for switching from the STOP mode to the SNOOZE mode, see **11.8 SNOOZE Mode Function**, **12.5.7 SNOOZE mode function** and **12.6.3 SNOOZE mode function**.

Remark (A) to (J) in Table 5-3 correspond to (A) to (J) in Figure 5-15.

5.6.5 Condition before changing CPU clock and processing after changing CPU clock

Condition before changing the CPU clock and processing after changing the CPU clock are shown below.

Table 5-4. Changing CPU Clock (1/2)

CPU Clock		Condition Before Change	Processing After Change
Before Change	After Change		
High-speed on-chip oscillator clock	X1 clock	Stabilization of X1 oscillation <ul style="list-style-type: none"> • OSCSEL = 1, EXCLK = 0, MSTOP = 0 • After elapse of oscillation stabilization time 	The operating current can be reduced by stopping the high-speed on-chip oscillator (HIOSTOP = 1) after checking that the CPU clock is changed.
	External main system clock	Enabling input of external clock from the EXCLK pin <ul style="list-style-type: none"> • OSCSEL = 1, EXCLK = 1, MSTOP = 0 	
	XT1 clock	Stabilization of XT1 oscillation <ul style="list-style-type: none"> • OSCSELS = 1, EXCLKS = 0, XTSTOP = 0 • After elapse of oscillation stabilization time 	
	External subsystem clock	Enabling input of external clock from the EXCLKS pin <ul style="list-style-type: none"> • OSCSELS = 1, EXCLKS = 1, XTSTOP = 0 	
X1 clock	High-speed on-chip oscillator clock	Enabling oscillation of high-speed on-chip oscillator <ul style="list-style-type: none"> • HIOSTOP = 0 • After elapse of oscillation accuracy stabilization time 	X1 oscillation can be stopped (MSTOP = 1) after checking that the CPU clock is changed.
	External main system clock	Transition not possible	–
	XT1 clock	Stabilization of XT1 oscillation <ul style="list-style-type: none"> • OSCSELS = 1, EXCLKS = 0, XTSTOP = 0 • After elapse of oscillation stabilization time 	X1 oscillation can be stopped (MSTOP = 1) after checking that the CPU clock is changed.
	External subsystem clock	Enabling input of external clock from the EXCLKS pin <ul style="list-style-type: none"> • OSCSELS = 1, EXCLKS = 1, XTSTOP = 0 	X1 oscillation can be stopped (MSTOP = 1) after checking that the CPU clock is changed.
External main system clock	High-speed on-chip oscillator clock	Enabling oscillation of high-speed on-chip oscillator <ul style="list-style-type: none"> • HIOSTOP = 0 • After elapse of oscillation accuracy stabilization time 	External main system clock input can be disabled (MSTOP = 1) after checking that the CPU clock is changed.
	X1 clock	Transition not possible	–
	XT1 clock	Stabilization of XT1 oscillation <ul style="list-style-type: none"> • OSCSELS = 1, EXCLKS = 0, XTSTOP = 0 • After elapse of oscillation stabilization time 	External main system clock input can be disabled (MSTOP = 1) after checking that the CPU clock is changed.
	External subsystem clock	Enabling input of external clock from the EXCLKS pin <ul style="list-style-type: none"> • OSCSELS = 1, EXCLKS = 1, XTSTOP = 0 	External main system clock input can be disabled (MSTOP = 1) after checking that the CPU clock is changed.

Table 5-4. Changing CPU Clock (2/2)

CPU Clock		Condition Before Change	Processing After Change
Before Change	After Change		
XT1 clock	High-speed on-chip oscillator clock	Oscillation of high-speed on-chip oscillator and selection of high-speed on-chip oscillator clock as main system clock <ul style="list-style-type: none"> • HIOSTOP = 0, MCS = 0 	XT1 oscillation can be stopped (XTSTOP = 1) after checking that the CPU clock is changed.
	X1 clock	Stabilization of X1 oscillation and selection of high-speed system clock as main system clock <ul style="list-style-type: none"> • OSCSEL = 1, EXCLK = 0, MSTOP = 0 • After elapse of oscillation stabilization time • MCS = 1 	
	External main system clock	Enabling input of external clock from the EXCLK pin and selection of high-speed system clock as main system clock <ul style="list-style-type: none"> • OSCSEL = 1, EXCLK = 1, MSTOP = 0 • MCS = 1 	
	External subsystem clock	Transition not possible	–
External subsystem clock	High-speed on-chip oscillator clock	Oscillation of high-speed on-chip oscillator and selection of high-speed on-chip oscillator clock as main system clock <ul style="list-style-type: none"> • HIOSTOP = 0, MCS = 0 	External subsystem clock input can be disabled (XTSTOP = 1) after checking that the CPU clock is changed.
	X1 clock	Stabilization of X1 oscillation and selection of high-speed system clock as main system clock <ul style="list-style-type: none"> • OSCSEL = 1, EXCLK = 0, MSTOP = 0 • After elapse of oscillation stabilization time • MCS = 1 	
	External main system clock	Enabling input of external clock from the EXCLK pin and selection of high-speed system clock as main system clock <ul style="list-style-type: none"> • OSCSEL = 1, EXCLK = 1, MSTOP = 0 • MCS = 1 	
	XT1 clock	Transition not possible	–

5.6.6 Time required for switchover of CPU clock and system clock

By setting bits 4 and 6 (MCM0, CSS) of the system clock control register (CKC), the CPU clock can be switched (between the main system clock and the subsystem clock), and main system clock can be switched (between the high-speed on-chip oscillator clock and the high-speed system clock).

The actual switchover operation is not performed immediately after rewriting to the CKC register; operation continues on the pre-switchover clock for several clocks (see **Table 5-5** to **Table 5-7**).

Whether the CPU is operating on the main system clock or the subsystem clock can be ascertained using bit 7 (CLS) of the CKC register. Whether the main system clock is operating on the high-speed system clock or high-speed on-chip oscillator clock can be ascertained using bit 5 (MCS) of the CKC register.

When the CPU clock is switched, the peripheral hardware clock is also switched.

Table 5-5. Maximum Time Required for System Clock Switchover

Clock A	Switching directions	Clock B	Remark
f _{IH}	↔	f _{MX}	See Table 5-6
f _{MAIN}	↔	f _{SUB}	See Table 5-7

Table 5-6. Maximum Number of Clocks Required for f_{IH} ↔ f_{MX}

Set Value Before Switchover		Set Value After Switchover	
MCM0		MCM0	
		0 (f _{MAIN} = f _{IH})	1 (f _{MAIN} = f _{MX})
0 (f _{MAIN} = f _{IH})	f _{MX} ≥ f _{IH}		2 clock
	f _{MX} < f _{IH}		2f _{IH} /f _{MX} clock
1 (f _{MAIN} = f _{MX})	f _{MX} ≥ f _{IH}	2f _{MX} /f _{IH} clock	
	f _{MX} < f _{IH}	2 clock	

Table 5-7. Maximum Number of Clocks Required for f_{MAIN} ↔ f_{SUB}

Set Value Before Switchover		Set Value After Switchover	
CSS		CSS	
		0 (f _{CLK} = f _{MAIN})	1 (f _{CLK} = f _{SUB})
0 (f _{CLK} = f _{MAIN})			1 + 2f _{MAIN} /f _{SUB} clock
1 (f _{CLK} = f _{SUB})		3 clock	

- Remarks 1.** The number of clocks listed in **Table 5-6** and **Table 5-7** is the number of CPU clocks before switchover.
2. Calculate the number of clocks in **Table 5-6** and **Table 5-7** by removing the decimal portion.

Example When switching the main system clock from the high-speed system clock to the high-speed on-chip oscillator clock (@ oscillation with f_{IH} = 8 MHz, f_{MX} = 10 MHz)
 2f_{MX}/f_{IH} = 2 (10/8) = 2.5 → 3 clocks

5.6.7 Conditions before clock oscillation is stopped

The following lists the register flag settings for stopping the clock oscillation (disabling external clock input) and conditions before the clock oscillation is stopped.

Before stopping the clock oscillation, check the conditions before the clock oscillation is stopped.

Table 5-8. Conditions Before the Clock Oscillation Is Stopped and Flag Settings

Clock	Conditions Before Clock Oscillation Is Stopped (External Clock Input Disabled)	Flag Settings of SFR Register
High-speed on-chip oscillator clock	MCS = 1 or CLS = 1 (The CPU is operating on a clock other than the high-speed on-chip oscillator clock.)	HIOSTOP = 1
X1 clock	MCS = 0 or CLS = 1 (The CPU is operating on a clock other than the high-speed system clock.)	MSTOP = 1
External main system clock		
XT1 clock	CLS = 0 (The CPU is operating on a clock other than the subsystem clock.)	XTSTOP = 1
External subsystem clock		

5.7 Resonator and Oscillator Constants

The resonators for which the operation is verified and their oscillator constants are shown below.

- Cautions 1.** The constants for these oscillator circuits are reference values based on specific environments set up for evaluation by the manufacturers. For actual applications, request evaluation by the manufacturer of the oscillator circuit mounted on a board. Furthermore, if you are switching from a different product to this microcontroller, and whenever you change the board, again request evaluation by the manufacturer of the oscillator circuit mounted on the new board.
- 2.** The oscillation voltage and oscillation frequency only indicate the oscillator characteristic. Use the RL78 microcontroller so that the internal operation conditions are within the specifications of the DC and AC characteristics.

Figure 5-16. External Oscillation Circuit Example



(1) X1 oscillation:

As of March, 2013 (1/2)

Manufacturer	Resonator	Part Number ^{Note 3}	SMD/Lead	Frequency (MHz)	Flash operation mode ^{Note 1}	Recommended Circuit Constants ^{Note 2} (reference)			Oscillation Voltage Range (V)	
						C1 (pF)	C2 (pF)	Rd (kΩ)	MIN.	MAX.
Murata Manufacturing Co., Ltd. ^{Note 4}	Ceramic resonator	CSTCC2M00G56-R0	SMD	2.0	LV	(47)	(47)	0	1.6	5.5
		CSTCR4M00G55-R0	SMD	4.0		(39)	(39)	0		
		CSTLS4M00G53-B0	Lead			(15)	(15)	0		
		CSTCC2M00G56-R0	SMD	2.0	LS	(47)	(47)	0	1.8	5.5
		CSTCR4M00G55-R0	SMD	4.0		(39)	(39)	0		
		CSTLS4M00G53-B0	Lead			(15)	(15)	0		
		CSTCR4M19G55-R0	SMD	4.194		(39)	(39)	0		
		CSTLS4M19G53-B0	Lead			(15)	(15)	0		
		CSTCR4M91G53-R0	SMD	4.915		(15)	(15)	0		
		CSTLS4M91G53-B0	Lead			(15)	(15)	0		
		CSTCR5M00G53-R0	SMD	5.0		(15)	(15)	0		
		CSTLS5M00G53-B0	Lead			(15)	(15)	0		
		CSTCR6M00G53-R0	SMD	6.0		(15)	(15)	0		
		CSTLS6M00G53-B0	Lead			(15)	(15)	0		
		CSTCE8M00G52-R0	SMD	8.0		(10)	(10)	0		
		CSTLS8M00G53-B0	Lead		(15)	(15)	0			
		CSTCE8M38G52-R0	SMD	8.388	HS	(10)	(10)	0	2.4	5.5
		CSTLS8M38G53-B0	Lead			(15)	(15)	0		
		CSTCE10M0G52-R0	SMD	10.0	10.0	(10)	(10)	0		
		CSTLS10M0G53-B0	Lead			(15)	(15)	0		
CSTCE12M0G52-R0	SMD	12.0	16.0	(10)	(10)	0				
CSTCE16M0V53-R0	SMD	16.0		(15)	(15)	0				
CSTLS16M0X51-B0	Lead		20.0	(5)	(5)	0	2.7	5.5		
CSTCE20M0V51-R0	SMD	20.0		(5)	(5)	0				
CSTLS20M0X51-B0	Lead			(5)	(5)	0				

- Notes 1.** Set the flash operation mode by using CMODE1 and CMODE0 bits of the option byte (000C2H).
- 2.** Values in parentheses in the C1 and C2 columns indicate an internal capacitance.
- 3.** Products supporting 105°C operation have different part numbers. For details, contact Murata Manufacturing Co., Ltd. (<http://www.murata.com>)
- 4.** When using this resonator, for details about the matching, contact Murata Manufacturing Co., Ltd. (<http://www.murata.com>).

- Remarks 1.** Relationship between operation voltage width, operation frequency of CPU and operation mode is as below.
- HS (high-speed main) mode: $2.7\text{ V} \leq V_{DD} \leq 5.5\text{ V}@1\text{ MHz to }32\text{ MHz}$
 $2.4\text{ V} \leq V_{DD} \leq 5.5\text{ V}@1\text{ MHz to }16\text{ MHz}$
- LS (low-speed main) mode: $1.8\text{ V} \leq V_{DD} \leq 5.5\text{ V}@1\text{ MHz to }8\text{ MHz}$
- LV (low-voltage main) mode: $1.6\text{ V} \leq V_{DD} \leq 5.5\text{ V}@1\text{ MHz to }4\text{ MHz}$
- 2.** A list of the resonators for which the operation has most recently been verified and their oscillation constants (for reference) is provided on the page for the corresponding product at the Renesas Web site (<http://www.renesas.com>).

As of March, 2013 (2/2)

Manufacturer	Resonator	Part Number ^{Note 2}	SMD/Lead	Frequency (MHz)	Flash operation mode ^{Note 1}	Recommended Circuit Constants (reference)			Oscillation Voltage Range (V)				
						C1 (pF)	C2 (pF)	Rd (kΩ)	MIN.	MAX.			
Nihon Dempa Kogyo Co., Ltd. ^{Note 3}	Crystal resonator	NX8045GB	SMD	8.0	Note 3								
		NX5032GA	SMD	16.0									
		NX3225HA	SMD	20.0									
Kyocera Crystal Device Co., Ltd. ^{Note 4}	Crystal resonator	CX8045GB04000D0PP TZ1	SMD	4.0	LV	12	12	0	1.6	5.5			
		LS			1.8				5.5				
		CX8045GB04915D0PP TZ1	SMD	4.915	LS	12	12	0	1.8	5.5			
		CX8045GB08000D0PP TZ1									12	12	0
		CX8045GB10000D0PP TZ1									12	12	0
		CX3225GB12000B0PP TZ1	SMD	12.0	HS	12	12	0	2.4	5.5			
		CX3225GB16000B0PP TZ1									5	5	0
CX3225SB20000B0PP TZ1	5	5									0		
RIVER ELETEC CORPORATION ^{Note 5}	Crystal resonator	FCX-03-8.000MHZ-J21140	SMD	8.0	HS	3	3	0	2.4	5.5			
		FCX-04C-10.000MHZ-J21139									4	4	0
		FCX-05-12.000MHZ-J21138									6	6	0
		FCX-06-16.000MHZ-J21137									4	4	0

- Notes 1.** Set the flash operation mode by using CMODE1 and CMODE0 bits of the option byte (000C2H).
- This resonator supports operation at up to 85°C. Contact crystal oscillator manufacturers with regard to products supporting operation at up to 105°C.
 - When using this resonator, for details about the matching, contact Nihon Dempa Kogyo Co., Ltd (<http://www.ndk.com/en>).
 - When using this resonator, for details about the matching, contact Kyocera Crystal Device Co., Ltd. (<http://www.kyocera-crystal.jp/eng/index.html>, <http://global.kyocera.com>).
 - When using this resonator, for details about the matching, contact RIVER ELETEC CORPORATION (<http://www.river-ele.co.jp/english/index.html>).

- Remarks 1.** Relationship between operation voltage width, operation frequency of CPU and operation mode is as below.
- HS (high-speed main) mode: $2.7\text{ V} \leq V_{DD} \leq 5.5\text{ V}@1\text{ MHz to }32\text{ MHz}$
 $2.4\text{ V} \leq V_{DD} \leq 5.5\text{ V}@1\text{ MHz to }16\text{ MHz}$
- LS (low-speed main) mode: $1.8\text{ V} \leq V_{DD} \leq 5.5\text{ V}@1\text{ MHz to }8\text{ MHz}$
- LV (low-voltage main) mode: $1.6\text{ V} \leq V_{DD} \leq 5.5\text{ V}@1\text{ MHz to }4\text{ MHz}$
- A list of the resonators for which the operation has most recently been verified and their oscillation constants (for reference) is provided on the page for the corresponding product at the Renesas Web site (<http://www.renesas.com>).

(2) XT1 oscillation: Crystal resonator

As of March, 2013

Manufacturer	Part Number <small>Note2</small>	SMD/ Lead	Frequency (KHz)	Load Capacitance CL (pF)	XT1 oscillation mode ^{Note1}	Recommended Circuit Constants			Oscillation Voltage Range					
						C3 (pF)	C4 (pF)	Rd (kΩ)	MIN. (V)	MAX. (V)				
Seiko Instruments Inc.	SSP-T7-F <small>Note3</small>	SMD	32.768	7	Normal oscillation	11	11	0	1.6	5.5				
				6		9	9	0						
	6			Low power consumption oscillation	9	9	0							
	4.4				6	5	0							
	4.4			Ultra-low power consumption oscillation	6	5	0							
	3.7				4	4	0							
	VT-200-FL <small>Note3</small>	Lead	6	Normal oscillation	9	9	0							
			6	Low power consumption oscillation	9	9	0							
			4.4		6	5	0							
			4.4	Ultra-low power consumption oscillation	6	5	0							
			3.7		4	4	0							
			Nihon Dempa Kogyo Co., Ltd.	NX3215SA <small>Note4</small>	SMD	32.768	6	Normal oscillation	7	7	0	1.6	5.5	
	Low power consumption oscillation													
	Ultra-low power consumption oscillation													
NX2012SA <small>Note4</small>	6	Normal oscillation		7			7	0						
		Low power consumption oscillation												
		Ultra-low power consumption oscillation												
Kyocera Crystal Device Co., Ltd.	ST3215SB <small>Note5</small>	SMD	32.768	7	Normal oscillation	10	10	0	1.6	5.5				
					Low power consumption oscillation									
					Ultra-low power consumption oscillation									
RIVER ELETEC CORPORATION	TFX-02- 32.768KHZ- J20986 ^{Note6}			SMD	32.768	9	Normal oscillation	12			10	0	1.6	5.5
							Low power consumption oscillation							
	TFX-03- 32.768KHZ- J13375 ^{Note6}			SMD	32.768	7	Normal oscillation	12			10	0	1.6	5.5

- Notes 1.** Set the XT1 oscillation mode by using AMPHS0 and AMPHS1 bits of the clock operation mode control register (CMC).
- This resonator supports operation at up to 85°C. Contact crystal oscillator manufacturers with regard to products supporting operation at up to 105°C.
 - This oscillator is a low-power-consumption product. When using it, for details about the matching, contact Seiko Instruments Inc., Ltd (<http://www.sii.co.jp/components/quartz/topEN.jsp>).
 - When using this resonator, for details about the matching, contact Nihon Dempa Kogyo Co., Ltd (<http://www.ndk.com/en>).
 - When using this resonator, for details about the matching, contact Kyocera Crystal Device Co., Ltd. (<http://www.kyocera-crystal.jp/eng/index.html>, <http://global.kyocera.com>).
 - When using this resonator, for details about the matching, contact RIVER ELETEC CORPORATION (<http://www.river-ele.co.jp/english/index.html>).

Remark A list of the resonators for which the operation has most recently been verified and their oscillation constants (for reference) is provided on the page for the corresponding product at the Renesas Web site (<http://www.renesas.com>).

CHAPTER 6 TIMER ARRAY UNIT

The number of units or channels of the timer array unit differs, depending on the product.

Units	Channels	20, 24, 25, 30, 32, 36, 40, 44, 48, 52, 64-pin	80, 100-pin	128-pin
Unit 0	Channel 0	√	√	√
	Channel 1	√	√	√
	Channel 2	√	√	√
	Channel 3	√	√	√
	Channel 4	√	√	√
	Channel 5	√	√	√
	Channel 6	√	√	√
	Channel 7	√	√	√
Unit 1	Channel 0	–	√	√
	Channel 1	–	√	√
	Channel 2	–	√	√
	Channel 3	–	√	√
	Channel 4	–	–	√
	Channel 5	–	–	√
	Channel 6	–	–	√
	Channel 7	–	–	√

Cautions 1. The presence or absence of timer I/O pins depends on the product. See Table 6-2 Timer I/O Pins provided in Each Product for details.

2. Most of the following descriptions in this chapter use the 128-pin products as an example.

The timer array unit has eight 16-bit timers.

Each 16-bit timer is called a channel and can be used as an independent timer. In addition, two or more “channels” can be used to create a high-accuracy timer.

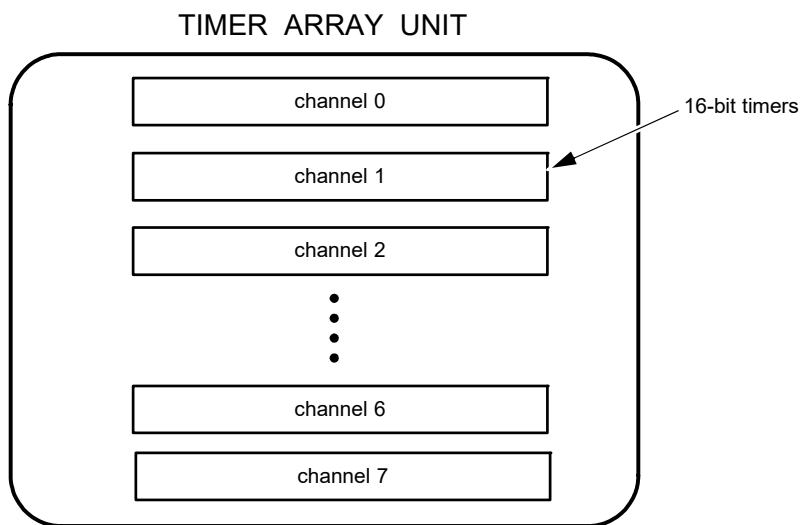

For details about each function, see the table below.

Independent channel operation function	Simultaneous channel operation function
<ul style="list-style-type: none"> • Interval timer (→ refer to 6.8.1) • Square wave output (→ refer to 6.8.1) • External event counter (→ refer to 6.8.2) • Divider Note (→ refer to 6.8.3) • Input pulse interval measurement → refer to 6.8.4) • Measurement of high-/low-level width of input signal (→ refer to 6.8.5) • Delay counter (→ refer to 6.8.6) 	<ul style="list-style-type: none"> • One-shot pulse output(→ refer to 6.9.1) • PWM output(→ refer to 6.9.2) • Multiple PWM output(→ refer to 6.9.3)

Note Only channel 0 of unit 0.

It is possible to use the 16-bit timer of channels 1 and 3 of the units 0 and 1 as two 8-bit timers (higher and lower). The functions that can use channels 1 and 3 as 8-bit timers are as follows:

- Interval timer (upper or lower 8-bit timer)/square wave output (lower 8-bit timer only)
- External event counter (lower 8-bit timer only)
- Delay counter (lower 8-bit timer only)

Channel 7 of unit 0 can be used to realize LIN-bus communication operating in combination with UART2 of the serial array unit (30, 32, 36, 40, 44, 48, 52, 64, 80, 100, and 128-pin products only).

6.1 Functions of Timer Array Unit

Timer array unit has the following functions.

6.1.1 Independent channel operation function

By operating a channel independently, it can be used for the following purposes without being affected by the operation mode of other channels.

(1) Interval timer

Each timer of a unit can be used as a reference timer that generates an interrupt (INTTMmn) at fixed intervals.

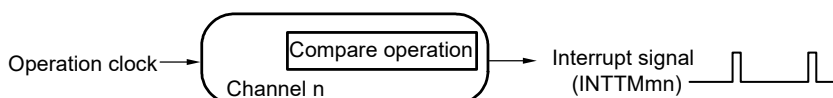

(2) Square wave output

A toggle operation is performed each time INTTMmn interrupt is generated and a square wave with a duty factor of 50% is output from a timer output pin (TOMn).

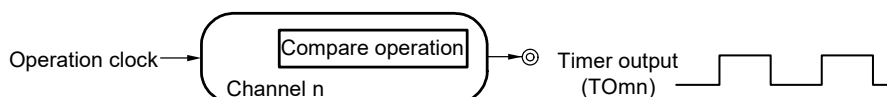

(3) External event counter

Each timer of a unit can be used as an event counter that generates an interrupt when the number of the valid edges of a signal input to the timer input pin (TIMn) has reached a specific value.

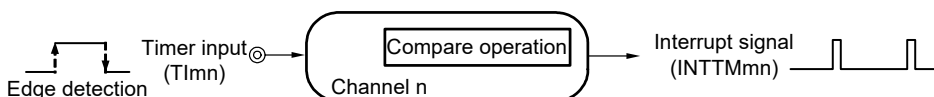

(4) Divider function (channel 0 only)

A clock input from a timer input pin (TI00) is divided and output from an output pin (TO00).

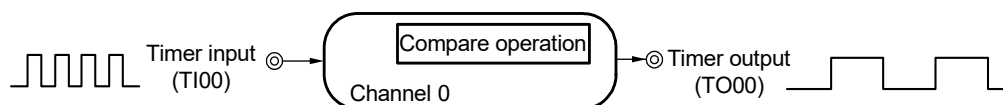

(5) Input pulse interval measurement

Counting is started by the valid edge of a pulse signal input to a timer input pin (TIMn). The count value of the timer is captured at the valid edge of the next pulse. In this way, the interval of the input pulse can be measured.

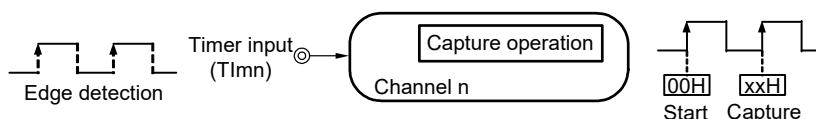

(6) Measurement of high-/low-level width of input signal

Counting is started by a single edge of the signal input to the timer input pin (TImn), and the count value is captured at the other edge. In this way, the high-level or low-level width of the input signal can be measured.

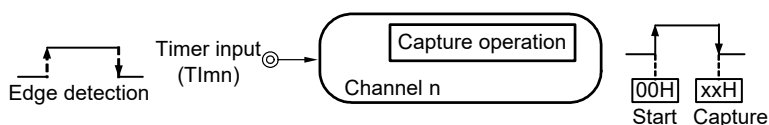

(7) Delay counter

Counting is started at the valid edge of the signal input to the timer input pin (TImn), and an interrupt is generated after any delay period.

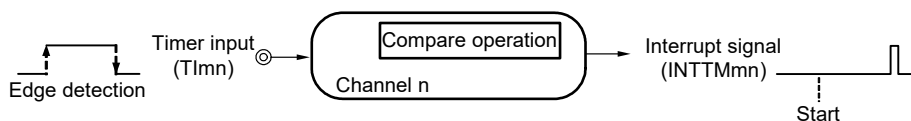

- Remarks 1** m: Unit number (m = 0, 1), n: Channel number (n = 0 to 7)
2. The presence or absence of timer I/O pins of channel 0 to 7 depends on the product. See **Table 6-2 Timer I/O Pins provided in Each Product** for details.

6.1.2 Simultaneous channel operation function

By using the combination of a master channel (a reference timer mainly controlling the cycle) and slave channels (timers operating according to the master channel), channels can be used for the following purposes.

(1) One-shot pulse output

Two channels are used as a set to generate a one-shot pulse with a specified output timing and a specified pulse width.

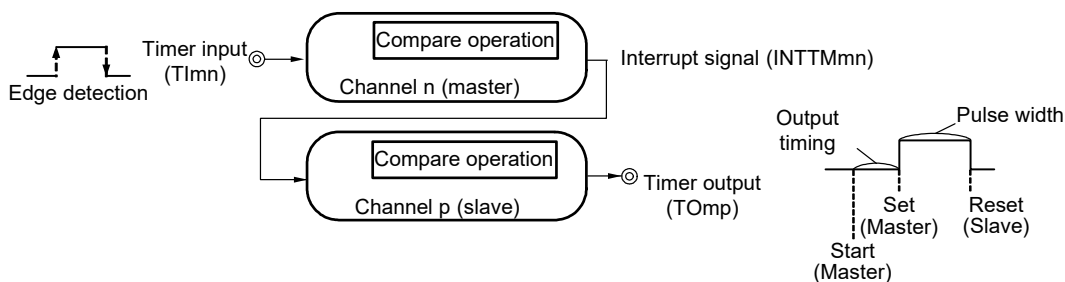

(2) PWM (Pulse Width Modulation) output

Two channels are used as a set to generate a pulse with a specified period and a specified duty factor.

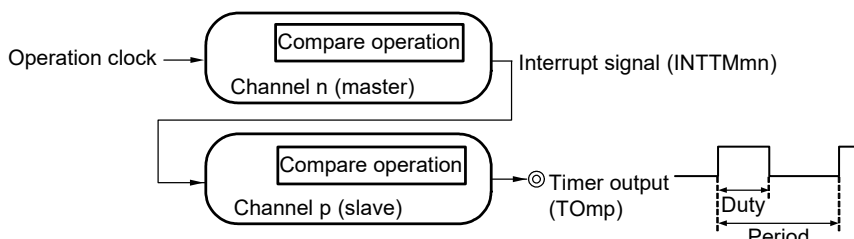

(3) Multiple PWM (Pulse Width Modulation) output

By extending the PWM function and using one master channel and two or more slave channels, up to seven types of PWM signals that have a specific period and a specified duty factor can be generated.

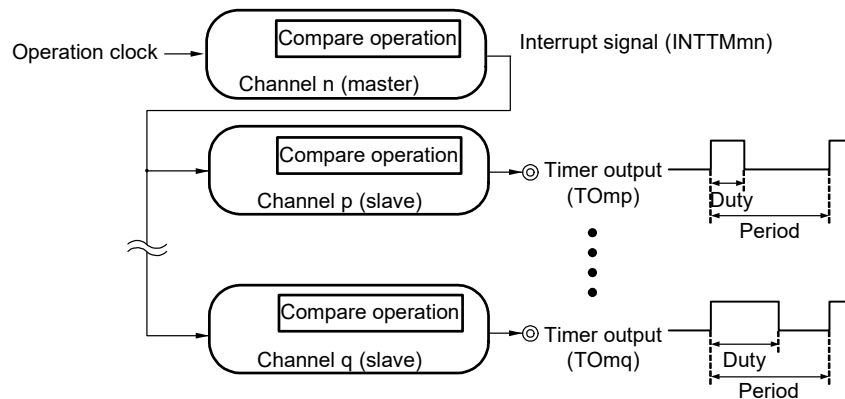

Caution For details about the rules of simultaneous channel operation function, see 6.4.1 Basic rules of simultaneous channel operation function.

Remark m: Unit number ($m = 0, 1$), n: Channel number ($n = 0$ to 7),
p, q: Slave channel number ($n < p < q \leq 7$)

6.1.3 8-bit timer operation function (channels 1 and 3 only)

The 8-bit timer operation function makes it possible to use a 16-bit timer channel in a configuration consisting of two 8-bit timer channels. This function can only be used for channels 1 and 3.

Caution There are several rules for using 8-bit timer operation function.
For details, see 6.4.2 Basic rules of 8-bit timer operation function (channels 1 and 3 only).

6.1.4 LIN-bus supporting function (channel 7 of unit 0 only)

Timer array unit is used to check whether signals received in LIN-bus communication match the LIN-bus communication format.

(1) Detection of wakeup signal

The timer starts counting at the falling edge of a signal input to the serial data input pin (RxD2) of UART2 and the count value of the timer is captured at the rising edge. In this way, a low-level width can be measured. If the low-level width is greater than a specific value, it is recognized as a wakeup signal.

(2) Detection of break field

The timer starts counting at the falling edge of a signal input to the serial data input pin (RxD2) of UART2 after a wakeup signal is detected, and the count value of the timer is captured at the rising edge. In this way, a low-level width is measured. If the low-level width is greater than a specific value, it is recognized as a break field.

(3) Measurement of pulse width of sync field

After a break field is detected, the low-level width and high-level width of the signal input to the serial data input pin (RxD2) of UART2 are measured. From the bit interval of the sync field measured in this way, a baud rate is calculated.

Remark For details about setting up the operations used to implement the LIN-bus, see **6.3.13 Input switch control register (ISC)** and **6.8.5 Operation as input signal high-/low-level width measurement**.

6.2 Configuration of Timer Array Unit

Timer array unit includes the following hardware.

Table 6-1. Configuration of Timer Array Unit

Item	Configuration
Timer/counter	Timer count register mn (TCRmn)
Register	Timer data register mn (TDRmn)
Timer input	TI00 to TI07, TI10 to TI17 ^{Note 1} , RxD2 pin (for LIN-bus)
Timer output	TO00 to TO07, TO10 to TO17 pins ^{Note 1} , output controller
Control registers	<p><Registers of unit setting block></p> <ul style="list-style-type: none"> ● Peripheral enable register 0 (PER0) ● Timer clock select register m (TPSm) ● Timer channel enable status register m (TEm) ● Timer channel start register m (TSm) ● Timer channel stop register m (TTm) ● Timer input select register 0 (TIS0) ● Timer output enable register m (TOEm) ● Timer output register m (TOm) ● Timer output level register m (TOLm) ● Timer output mode register m (TOMm) <hr/> <p><Registers of each channel></p> <ul style="list-style-type: none"> ● Timer mode register mn (TMRmn) ● Timer status register mn (TSRmn) ● Input switch control register (ISC) ● Noise filter enable registers 1, 2 (NFEN1, NFEN2) ● Port mode control register (PMCxx) ^{Note 2} ● Port mode register (PMxx) ^{Note 2} ● Port register (Pxx) ^{Note 2}

Notes 1. The presence or absence of timer I/O pins of channel 0 to 7 depends on the product. See **Table 6-2 Timer I/O Pins provided in Each Product** for details.

2. The Port mode control register (PMCxx), port mode registers (PMxx) and port registers (Pxx) to be set differ depending on the product. for details, see **4.5.3 Register setting examples for used port and alternate functions**.

Remark m: Unit number (m = 0, 1), n: Channel number (n = 0 to 7)

The presence or absence of timer I/O pins in each timer array unit channel depends on the product.

Table 6-2. Timer I/O Pins provided in Each Product

Timer array unit channels		I/O Pins of Each Product								
		128-pin	100-pin	80-pin	64-pin	52-pin	44, 48-pin	40-pin	30, 32, 36-pin	24, 25-pin
Unit 0	Channel 0	TI00, TO00								
	Channel 1	TI01/TO01								
	Channel 2	TI02/TO02								
	Channel 3	TI03/TO03								–
	Channel 4	TI04/TO04			(TI04/TO04)	(TI04/TO04)	(TI04/TO04)	(TI04/TO04)	–	–
	Channel 5	TI05/TO05	TI05/TO05		(TI05/TO05)	(TI05/TO05)	(TI05/TO05)	(TI05/TO05)	–	–
	Channel 6	TI06/TO06	TI06/TO06		(TI06/TO06)	(TI06/TO06)	(TI06/TO06)	(TI06/TO06)	–	–
	Channel 7	TI07/TO07	TI07/TO07				(TI07/TO07)	(TI07/TO07)	–	–
Unit 1	Channel 0	TI10/TO10		x	x	x	x	x	x	x
	Channel 1	TI11/TO11		x	x	x	x	x	x	x
	Channel 2	TI12/TO12		x	x	x	x	x	x	x
	Channel 3	TI13/TO13		x	x	x	x	x	x	x
	Channel 4	TI14/TO14	x	x	x	x	x	x	x	x
	Channel 5	TI15/TO15	x	x	x	x	x	x	x	x
	Channel 6	TI16/TO16	x	x	x	x	x	x	x	x
	Channel 7	TI17/TO17	x	x	x	x	x	x	x	x

- Remarks**
1. When timer input and timer output are shared by the same pin, either only timer input or only timer output can be used.
 2. –: There is no timer I/O pin, but the channel is available. (However, the channel can only be used as an interval timer.)
x: The channel is not available.
 3. Pins in the parentheses indicate an alternate port when the bit 0 of the peripheral I/O redirection register (PIOR) is set to “1”.

Figure 6-1 shows the block diagrams of the timer array unit.

Figure 6-1. Entire Configuration of Timer Array Unit 0 (Example: 64-pin products)

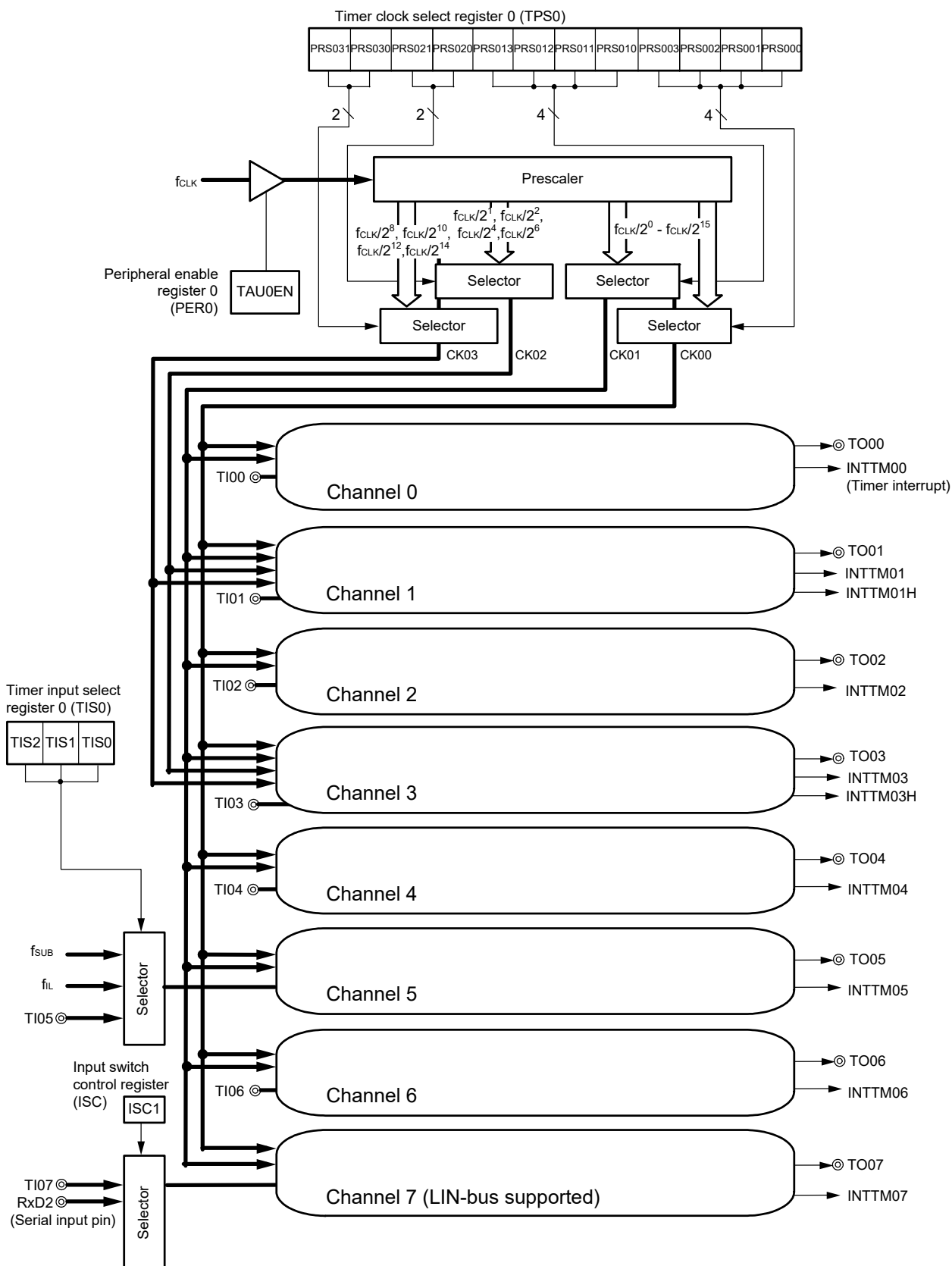

Remark f_{SUB} : Subsystem clock frequency
 f_{IL} : Low-speed on-chip oscillator clock frequency

Figure 6-2. Internal Block Diagram of Channels 0, 2, 4, 6 of Timer Array Unit 0

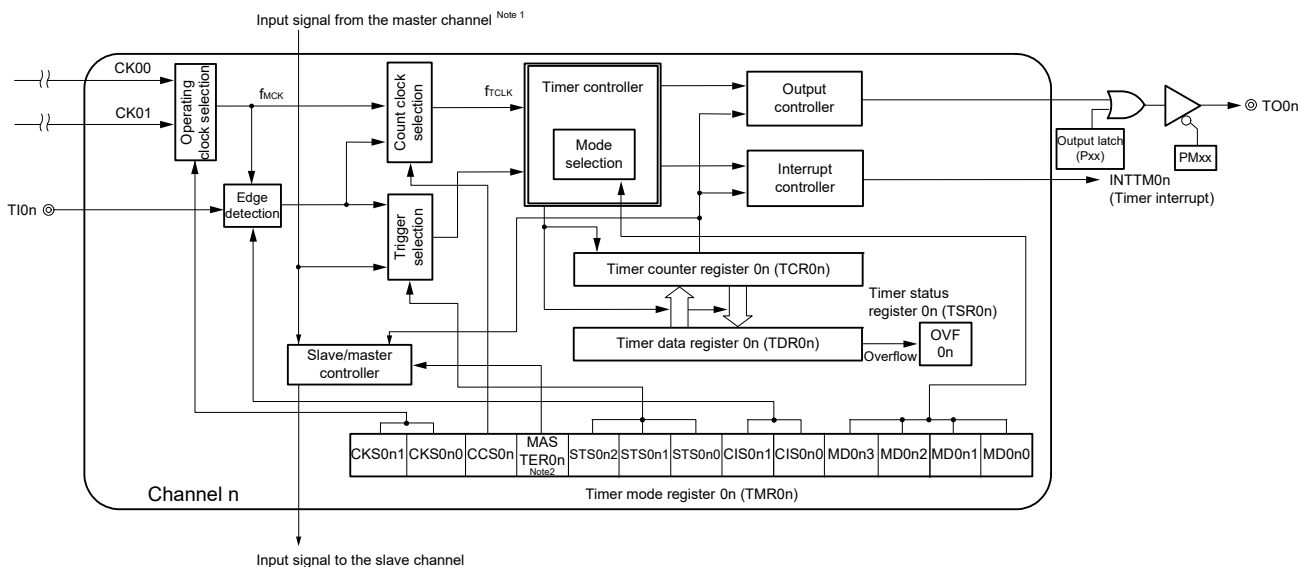

Notes 1. Channels 2, 4, and 6 only

2. n = 2, 4, 6 only

Remark n = 0, 2, 4, 6

Figure 6-3. Internal Block Diagram of Channels 1 and 3 of Timer Array Unit 0

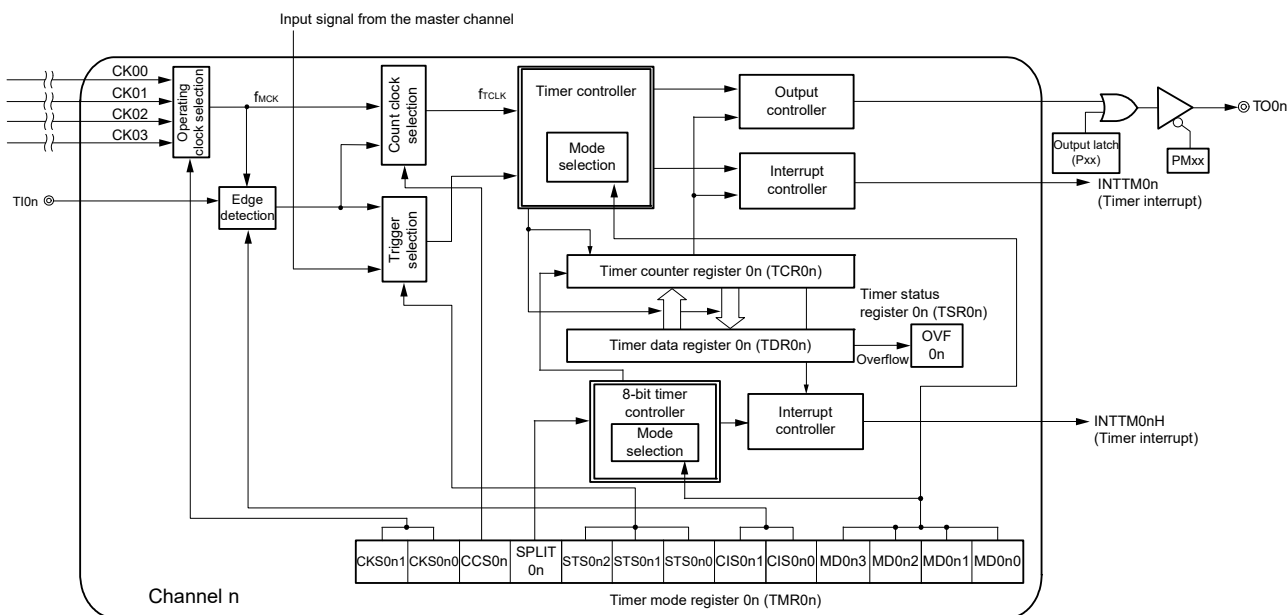

Remark n = 1, 3

Figure 6-4. Internal Block Diagram of Channel 5 of Timer Array Unit 0

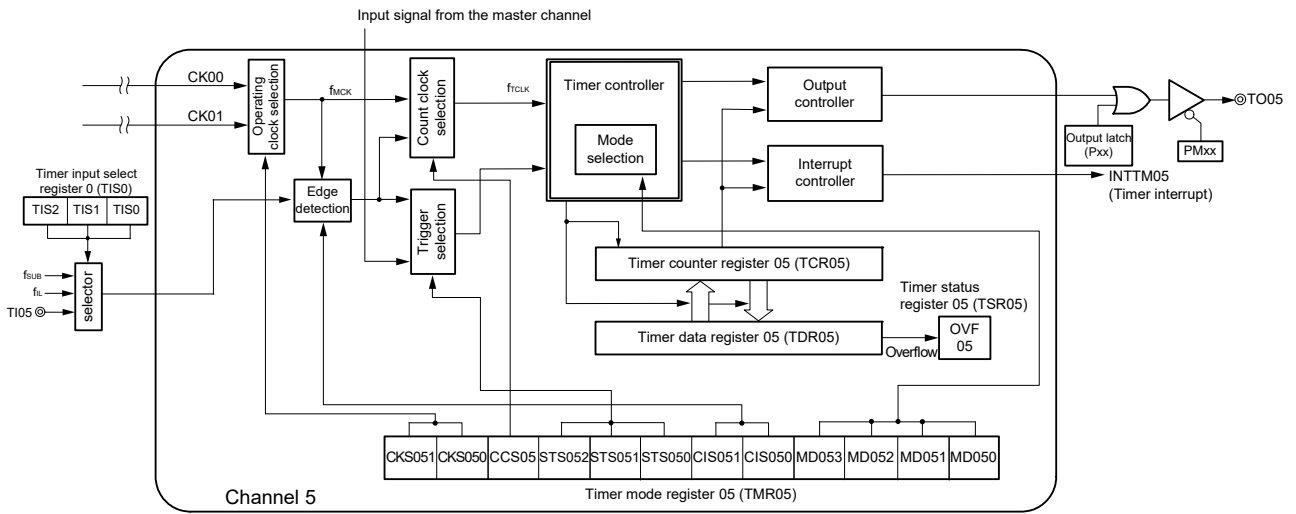
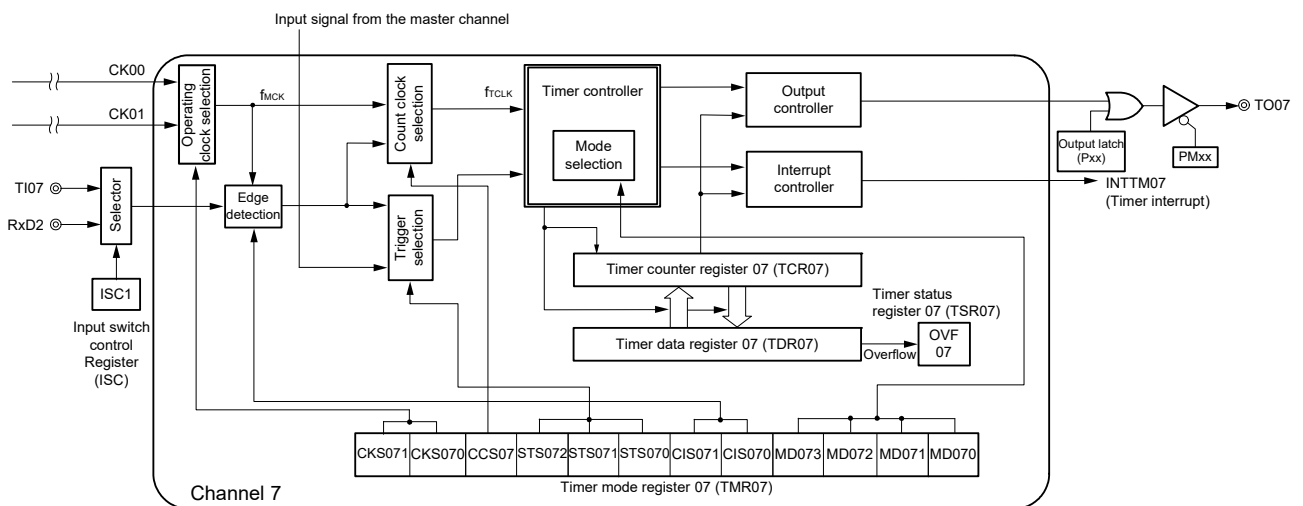

Figure 6-5. Internal Block Diagram of Channel 7 of Timer Array Unit 0



6.2.1 Timer count register mn (TCRmn)

The TCRmn register is a 16-bit read-only register and is used to count clocks.

The value of this counter is incremented or decremented in synchronization with the rising edge of a count clock.

Whether the counter is incremented or decremented depends on the operation mode that is selected by the MDmn3 to MDmn0 bits of timer mode register mn (TMRmn) (refer to 6.3.3 Timer mode register mn (TMRmn)).

Figure 6-6. Format of Timer Count Register mn (TCRmn)

Address: F0180H, F0181H (TCR00) to F018EH, F018FH (TCR07), After reset: FFFFH R
 F01C0H, F01C1H (TCR10) to F01CEH, F01CFH (TCR17)

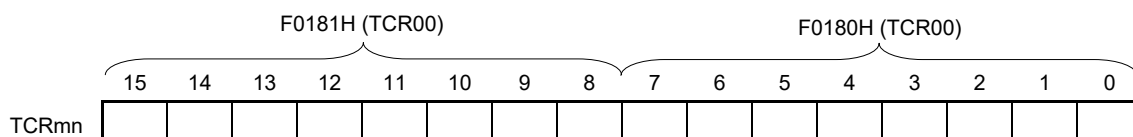

Remark m: Unit number (m = 0, 1), n: Channel number (n = 0 to 7)

The count value can be read by reading timer count register mn (TCRmn).

The count value is set to FFFFH in the following cases.

- When the reset signal is generated
- When the TAUmEN bit of peripheral enable register 0 (PER0) is cleared
- When counting of the slave channel has been completed in the PWM output mode
- When counting of the slave channel has been completed in the delay count mode
- When counting of the master/slave channel has been completed in the one-shot pulse output mode
- When counting of the slave channel has been completed in the multiple PWM output mode

The count value is cleared to 0000H in the following cases.

- When the start trigger is input in the capture mode
- When capturing has been completed in the capture mode

Caution The count value is not captured to timer data register mn (TDRmn) even when the TCRmn register is read.

The TCRmn register read value differs as follows according to operation mode changes and the operating status.

Table 6-3. Timer Count Register mn (TCRmn) Read Value in Various Operation Modes

Operation Mode	Count Mode	Timer count register mn (TCRmn) Read Value ^{Note}			
		Value if the operation mode was changed after releasing reset	Value if the Operation was restarted after count operation paused (TTmn = 1)	Value if the operation mode was changed after count operation paused (TTmn = 1)	Value when waiting for a start trigger after one count
Interval timer mode	Count down	FFFFH	Value if stop	Undefined	–
Capture mode	Count up	0000H	Value if stop	Undefined	–
Event counter mode	Count down	FFFFH	Value if stop	Undefined	–
One-count mode	Count down	FFFFH	Value if stop	Undefined	FFFFH
Capture & one-count mode	Count up	0000H	Value if stop	Undefined	Capture value of TDRmn register + 1

Note This indicates the value read from the TCRmn register when channel n has stopped operating as a timer (TEmn = 0) and has been enabled to operate as a counter (TSmn = 1). The read value is held in the TCRmn register until the count operation starts.

Remark m: Unit number (m = 0, 1), n: Channel number (n = 0 to 7)

6.2.2 Timer data register mn (TDRmn)

This is a 16-bit register from which a capture function and a compare function can be selected.

The capture or compare function can be switched by selecting an operation mode by using the MDmn3 to MDmn0 bits of timer mode register mn (TMRmn).

The value of the TDRmn register can be changed at any time.

This register can be read or written in 16-bit units.

In addition, for the TDRm1 and TDRm3 registers, while in the 8-bit timer mode (when the SPLITm1, SPLITm3 bits of timer mode registers m1 and m3 (TMRm1, TMRm3) are 1), it is possible to read and write the data in 8-bit units, with TDRm1H and TDRm3H used as the higher 8 bits, and TDRm1L and TDRm3L used as the lower 8 bits.

Reset signal generation clears this register to 0000H.

Figure 6-7. Format of Timer Data Register mn (TDRmn) (n = 0, 2, 4 to 7)

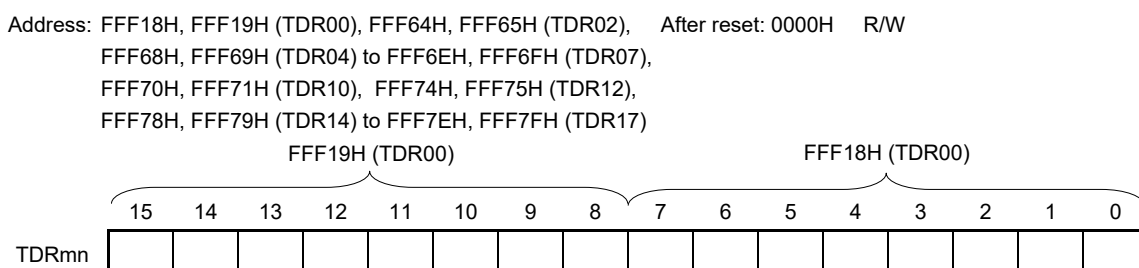
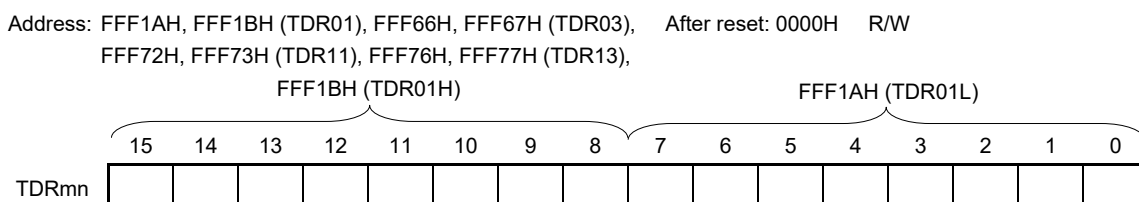

Figure 6-8. Format of Timer Data Register mn (TDRmn) (n = 1, 3)



(i) When timer data register mn (TDRmn) is used as compare register

Counting down is started from the value set to the TDRmn register. When the count value reaches 0000H, an interrupt signal (INTTMmn) is generated. The TDRmn register holds its value until it is rewritten.

Caution The TDRmn register does not perform a capture operation even if a capture trigger is input, when it is set to the compare function.

(ii) When timer data register mn (TDRmn) is used as capture register

The count value of timer count register mn (TCRmn) is captured to the TDRmn register when the capture trigger is input.

A valid edge of the TImn pin can be selected as the capture trigger. This selection is made by timer mode register mn (TMRmn).

Remark m: Unit number (m = 0, 1), n: Channel number (n = 0 to 7)

6.3 Registers Controlling Timer Array Unit

Timer array unit is controlled by the following registers.

- Peripheral enable register 0 (PER0)
- Timer clock select register m (TPSm)
- Timer mode register mn (TMRmn)
- Timer status register mn (TSRmn)
- Timer channel enable status register m (TEm)
- Timer channel start register m (TSm)
- Timer channel stop register m (TTm)
- Timer input select register 0 (TIS0)
- Timer output enable register m (TOEm)
- Timer output register m (TOM)
- Timer output level register m (TOLm)
- Timer output mode register m (TOMm)
- Input switch control register (ISC)
- Noise filter enable registers 1, 2 (NFEN1, NFEN2)
- Port mode control register (PMCxx)
- Port mode register (PMxx)
- Port register (Pxx)

Caution Which registers and bits are included depends on the product. Be sure to set bits that are not mounted to their initial values.

Remark m: Unit number (m = 0, 1), n: Channel number (n = 0 to 7)

6.3.1 Peripheral enable register 0 (PER0)

This registers is used to enable or disable supplying the clock to the peripheral hardware. Clock supply to a hardware macro that is not used is stopped in order to reduce the power consumption and noise.

When the timer array unit 0 is used, be sure to set bit 0 (TAU0EN) of this register to 1.

When the timer array unit 1 is used, be sure to set bit 1 (TAU1EN) of this register to 1.

The PER0 register can be set by a 1-bit or 8-bit memory manipulation instruction.

Reset signal generation clears this register to 00H.

Figure 6-9. Format of Peripheral Enable Register 0 (PER0)

Address: F00F0H After reset: 00H R/W

Symbol	<7>	<6>	<5>	<4>	<3>	<2>	<1>	<0>
PER0	RTCEN	IICA1EN ^{Note 1}	ADCEN	IICA0EN ^{Note 2}	SAU1EN ^{Note 3}	SAU0EN	TAU1EN ^{Note 1}	TAU0EN

TAU1EN	Control of timer array unit 1 input clock
0	Stops supply of input clock. <ul style="list-style-type: none"> • SFR used by the timer array unit 1 cannot be written. • The timer array unit 1 is in the reset status.
1	Supplies input clock. <ul style="list-style-type: none"> • SFR used by the timer array unit 1 can be read/written.

TAU0EN	Control of timer array 0 unit input clock
0	Stops supply of input clock. <ul style="list-style-type: none"> • SFR used by the timer array unit 0 cannot be written. • The timer array unit 0 is in the reset status.
1	Supplies input clock. <ul style="list-style-type: none"> • SFR used by the timer array unit 0 can be read/written.

Notes 1. 80, 100, and 128-pin products only.

2. This is not provided in the 20-pin products.

3. This is not provided in the 20, 24, and 25-pin products.

Cautions 1. When setting the timer array unit, be sure to set the following registers first while the TAUmEN bit is set to 1. If TAUmEN = 0, the values of the registers which control the timer array unit are cleared to their initial values and writing to them is ignored (except for timer input select register 0 (TIS0), input switch control register (ISC), noise filter enable register 1, 2 (NFEN1, NFEN2), port mode control register 0, 3, 14 (PMC0, PMC3, PMC14), port mode register 0, 1, 3, 4, 6, 10, 14 (PM0, PM1, PM3, PM4, PM6, PM10, PM14), port register 0, 1, 3, 4, 6, 10, 14 (P0, P1, P3, P4, P6, P10, P14)).

- Timer clock select register m (TPSm)
- Timer mode register mn (TMRmn)
- Timer status register mn (TSRmn)
- Timer channel enable status register m (TEm)
- Timer channel start register m (TSm)
- Timer channel stop register m (TTm)
- Timer output enable register m (TOEm)
- Timer output register m (TOM)
- Timer output level register m (TOLm)
- Timer output mode register m (TOMm)

2. Be sure to clear the following bits to 0.

20-pin products: bits 1, 3, 4, 6

24, 25-pin products: bits 1, 3, 6

30, 32, 36, 40, 44, 48, 52, 64-pin products: bits 1, 6

6.3.2 Timer clock select register m (TPSm)

The TPSm register is a 16-bit register that is used to select two types or four types of operation clocks (CKm0, CKm1, CKm2, CKm3) that are commonly supplied to each channel. CKm0 is selected by using bits 3 to 0 of the TPSm register, and CKm1 is selected by using bits 7 to 4 of the TPSm register. In addition, only for channels 1 and 3, CKm2 and CKm3 can be also selected. CKm2 is selected by using bits 9 and 8 of the TPSm register, and CKm3 is selected by using bits 13 and 12 of the TPSm register.

Rewriting of the TPSm register during timer operation is possible only in the following cases.

If the PRSm00 to PRSm03 bits can be rewritten (n = 0 to 7):

All channels for which CKm0 is selected as the operation clock (CKSmn1, CKSmn0 = 0, 0) are stopped (TEmn = 0).

If the PRSm10 to PRSm13 bits can be rewritten (n = 0 to 7):

All channels for which CKm1 is selected as the operation clock (CKSmn1, CKSmn0 = 0, 1) are stopped (TEmn = 0).

If the PRSm20 and PRSm21 bits can be rewritten (n = 1, 3):

All channels for which CKm2 is selected as the operation clock (CKSmn1, CKSmn0 = 1, 0) are stopped (TEmn = 0).

If the PRSm30 and PRSm31 bits can be rewritten (n = 1, 3):

All channels for which CKm3 is selected as the operation clock (CKSmn1, CKSmn0 = 1, 1) are stopped (TEmn = 0).

The TPSm register can be set by a 16-bit memory manipulation instruction.

Reset signal generation clears this register to 0000H.

Figure 6-10. Format of Timer Clock Select register m (TPSm) (1/2)

Address: F01B6H, F01B7H (TPS0), F01F6H, F01F7H (TPS1) After reset: 0000H R/W

Symbol	15	14	13	12	11	10	9	8	7	6	5	4	3	2	1	0
TPSm	0	0	PRS m31	PRS m30	0	0	PRS m21	PRS m20	PRS m13	PRS m12	PRS m11	PRS m10	PRS m03	PRS m02	PRS m01	PRS m00

PRS mk3	PRS mk2	PRS mk1	PRS mk0	Selection of operation clock (CKmk) ^{Note(k = 0, 1)}	f _{CLK} = 2 MHz	f _{CLK} = 5 MHz	f _{CLK} = 10 MHz	f _{CLK} = 20 MHz	f _{CLK} = 32 MHz
					f _{CLK}	2 MHz	5 MHz	10 MHz	20 MHz
0	0	0	0	f _{CLK} /2	1 MHz	2.5 MHz	5 MHz	10 MHz	16 MHz
0	0	1	0	f _{CLK} /2 ²	500 kHz	1.25 MHz	2.5 MHz	5 MHz	8 MHz
0	0	1	1	f _{CLK} /2 ³	250 kHz	625 kHz	1.25 MHz	2.5 MHz	4 MHz
0	1	0	0	f _{CLK} /2 ⁴	125 kHz	313 kHz	625 kHz	1.25 MHz	2 MHz
0	1	0	1	f _{CLK} /2 ⁵	62.5 kHz	156 kHz	313 kHz	625 kHz	1 MHz
0	1	1	0	f _{CLK} /2 ⁶	31.3 kHz	78.1 kHz	156 kHz	313 kHz	500 kHz
0	1	1	1	f _{CLK} /2 ⁷	15.6 kHz	39.1 kHz	78.1 kHz	156 kHz	250 kHz
1	0	0	0	f _{CLK} /2 ⁸	7.81 kHz	19.5 kHz	39.1 kHz	78.1 kHz	125 kHz
1	0	0	1	f _{CLK} /2 ⁹	3.91 kHz	9.77 kHz	19.5 kHz	39.1 kHz	62.5 kHz
1	0	1	0	f _{CLK} /2 ¹⁰	1.95 kHz	4.88 kHz	9.77 kHz	19.5 kHz	31.3 kHz
1	0	1	1	f _{CLK} /2 ¹¹	977 Hz	2.44 kHz	4.88 kHz	9.77 kHz	15.6 kHz
1	1	0	0	f _{CLK} /2 ¹²	488 Hz	1.22 kHz	2.44 kHz	4.88 kHz	7.81 kHz
1	1	0	1	f _{CLK} /2 ¹³	244 Hz	610 Hz	1.22 kHz	2.44 kHz	3.91 kHz
1	1	1	0	f _{CLK} /2 ¹⁴	122 Hz	305 Hz	610 Hz	1.22 kHz	1.95 kHz
1	1	1	1	f _{CLK} /2 ¹⁵	61.0 Hz	153 Hz	305 Hz	610 Hz	977 Hz

Note When changing the clock selected for f_{CLK} (by changing the system clock control register (CKC) value), stop timer array unit (TTm = 00FFH).

- Cautions**
1. Be sure to clear bits 15, 14, 11, 10 to “0”.
 2. If f_{CLK} (undivided) is selected as the operation clock (CKmk) and TDRnm is set to 0000H (n = 0 or 1, m = 0 to 7), interrupt requests output from timer array units cannot be used.

- Remarks**
1. f_{CLK}: CPU/peripheral hardware clock frequency
 2. Waveform of the clock to be selected in the TPSm register which becomes high level for one period of f_{CLK} from its rising edge (m = 1 to 15). For details, see 6.5.1 Count clock (f_{rCLK}).

Figure 6-10. Format of Timer Clock Select register m (TPSm) (2/2)

Address: F01B6H, F01B7H (TPS0), F01F6H, F01F7H (TPS1) After reset: 0000H R/W

Symbol	15	14	13	12	11	10	9	8	7	6	5	4	3	2	1	0
TPSm	0	0	PRS m31	PRS m30	0	0	PRS m21	PRS m20	PRS m13	PRS m12	PRS m11	PRS m10	PRS m03	PRS m02	PRS m01	PRS m00

PRS m21	PRS m20	Selection of operation clock (CKm2) ^{Note}					
		$f_{CLK} = 2 \text{ MHz}$	$f_{CLK} = 5 \text{ MHz}$	$f_{CLK} = 10 \text{ MHz}$	$f_{CLK} = 20 \text{ MHz}$	$f_{CLK} = 32 \text{ MHz}$	
0	0	$f_{CLK}/2$	1 MHz	2.5 MHz	5 MHz	10 MHz	16 MHz
0	1	$f_{CLK}/2^2$	500 kHz	1.25 MHz	2.5 MHz	5 MHz	8 MHz
1	0	$f_{CLK}/2^4$	125 kHz	313 kHz	625 MHz	1.25 MHz	2 MHz
1	1	$f_{CLK}/2^6$	31.3 kHz	78.1 kHz	156 kHz	313 kHz	500 kHz

PRS m31	PRS m30	Selection of operation clock (CKm3) ^{Note}					
		$f_{CLK} = 2 \text{ MHz}$	$f_{CLK} = 5 \text{ MHz}$	$f_{CLK} = 10 \text{ MHz}$	$f_{CLK} = 20 \text{ MHz}$	$f_{CLK} = 32 \text{ MHz}$	
0	0	$f_{CLK}/2^8$	7.81 kHz	19.5 kHz	39.1 kHz	78.1 kHz	125 kHz
0	1	$f_{CLK}/2^{10}$	1.95 kHz	4.88 kHz	9.77 kHz	19.5 kHz	31.3 kHz
1	0	$f_{CLK}/2^{12}$	488 Hz	1.22 kHz	2.44 kHz	4.88 kHz	7.81 kHz
1	1	$f_{CLK}/2^{14}$	122 Hz	305 Hz	610 Hz	1.22 kHz	1.95 kHz

Note When changing the clock selected for f_{CLK} (by changing the system clock control register (CKC) value), stop timer array unit (TTm = 00FFH).
The timer array unit must also be stopped if the operating clock (f_{MCK}) or the valid edge of the signal input from the TIMn pin is selected.

Caution Be sure to clear bits 15, 14, 11, 10 to “0”.

By using channels 1 and 3 in the 8-bit timer mode and specifying CKm2 or CKm3 as the operation clock, the interval times shown in Table 6-4 can be achieved by using the interval timer function.

Table 6-4. Interval Times Available for Operation Clock CKSm2 or CKSm3

Clock		Interval time ^{Note} ($f_{CLK} = 32 \text{ MHz}$)			
		10 μs	100 μs	1 ms	10 ms
CKm2	$f_{CLK}/2$	√	–	–	–
	$f_{CLK}/2^2$	√	–	–	–
	$f_{CLK}/2^4$	√	√	–	–
	$f_{CLK}/2^6$	√	√	–	–
CKm3	$f_{CLK}/2^8$	–	√	√	–
	$f_{CLK}/2^{10}$	–	√	√	–
	$f_{CLK}/2^{12}$	–	–	√	√
	$f_{CLK}/2^{14}$	–	–	√	√

Note The margin is within 5%.

- Remarks**
1. f_{CLK} : CPU/peripheral hardware clock frequency
 2. For details of a signal of $f_{CLK}/2^i$ selected with the TPSm register, see **6.5.1 Count clock (f_{rCLK})**.

6.3.3 Timer mode register mn (TMRmn)

The TMRmn register sets an operation mode of channel n. This register is used to select the operation clock (f_{MCK}), select the count clock, select the master/slave, select the 16 or 8-bit timer (only for channels 1 and 3), specify the start trigger and capture trigger, select the valid edge of the timer input, and specify the operation mode (interval, capture, event counter, one-count, or capture and one-count).

Rewriting the TMRmn register is prohibited when the register is in operation (when $TE_{mn} = 1$). However, bits 7 and 6 (CIS_{mn1} , CIS_{mn0}) can be rewritten even while the register is operating with some functions (when $TE_{mn} = 1$) (for details, see **6.8 Independent Channel Operation Function of Timer Array Unit** and **6.9 Simultaneous Channel Operation Function of Timer Array Unit**).

The TMRmn register can be set by a 16-bit memory manipulation instruction.
Reset signal generation clears this register to 0000H.

Caution The bits mounted depend on the channels in the bit 11 of TMRmn register.

TMRm2, TMRm4, TMRm6: MASTERmn bit (n = 2, 4, 6)

TMRm1, TMRm3: SPLITmn bit (n = 1, 3)

TMRm0, TMRm5, TMRm7: Fixed to 0

Figure 6-11. Format of Timer Mode Register mn (TMRmn) (1/4)

Address: F0190H, F0191H (TMR00) to F019EH, F019FH (TMR07) After reset: 0000H R/W
 F01D0H, F01D1H (TMR10) to F01DEH, F01DFH (TMR17)

Symbol	15	14	13	12	11	10	9	8	7	6	5	4	3	2	1	0
TMRmn (n = 2, 4, 6)	CKS mn1	CKS mn0	0	CCS mn	MAST ERmn	STS mn2	STS mn1	STS mn0	CIS mn1	CIS mn0	0	0	MD mn3	MD mn2	MD mn1	MD mn0

Symbol	15	14	13	12	11	10	9	8	7	6	5	4	3	2	1	0
TMRmn (n = 1, 3)	CKS mn1	CKS mn0	0	CCS mn	SPLIT mn	STS mn2	STS mn1	STS mn0	CIS mn1	CIS mn0	0	0	MD mn3	MD mn2	MD mn1	MD mn0

Symbol	15	14	13	12	11	10	9	8	7	6	5	4	3	2	1	0
TMRmn (n = 0, 5, 7)	CKS mn1	CKS mn0	0	CCS mn	0 ^{Note}	STS mn2	STS mn1	STS mn0	CIS mn1	CIS mn0	0	0	MD mn3	MD mn2	MD mn1	MD mn0

CKS mn1	CKS mn0	Selection of operation clock (f _{MCK}) of channel n
0	0	Operation clock CKm0 set by timer clock select register m (TPSm)
0	1	Operation clock CKm2 set by timer clock select register m (TPSm)
1	0	Operation clock CKm1 set by timer clock select register m (TPSm)
1	1	Operation clock CKm3 set by timer clock select register m (TPSm)
Operation clock (f _{MCK}) is used by the edge detector. A count clock (f _{TCLK}) and a sampling clock are generated depending on the setting of the CCSmn bit.		
The operation clocks CKm2 and CKm3 can only be selected for channels 1 and 3.		

CCS mn	Selection of count clock (f _{TCLK}) of channel n
0	Operation clock (f _{MCK}) specified by the CKSmn0 and CKSmn1 bits
1	Valid edge of input signal input from the TImn pin In channel 5, Valid edge of input signal selected by TIS0 In channel 7, Valid edge of input signal selected by ISC
Count clock (f _{TCLK}) is used for the counter, output controller, and interrupt controller.	

Note Bit 11 is a read-only bit and fixed to 0. Writing to this bit is ignored.

- Cautions**
1. Be sure to clear bits 13, 5, and 4 to 0.
 2. The timer array unit must be stopped (TTm = 00FFH) if the clock selected for f_{CLK} is changed (by changing the value of the system clock control register (CKC)), even if the operating clock specified by using the CKSmn0 and CKSmn1 bits (f_{MCK}) or the valid edge of the signal input from the TImn pin is selected as the count clock (f_{TCLK}).

Remark m: Unit number (m = 0, 1), n: Channel number (n = 0 to 7)

Figure 6-11. Format of Timer Mode Register mn (TMRmn) (2/4)

Address: F0190H, F0191H (TMR00) to F019EH, F019FH (TMR07) After reset: 0000H R/W
 F01D0H, F01D1H (TMR10) to F01DEH, F01DFH (TMR17)

Symbol	15	14	13	12	11	10	9	8	7	6	5	4	3	2	1	0
TMRmn (n = 2, 4, 6)	CKS mn1	CKS mn0	0	CCS mn	MAST ERmn	STS mn2	STS mn1	STS mn0	CIS mn1	CIS mn0	0	0	MD mn3	MD mn2	MD mn1	MD mn0

Symbol	15	14	13	12	11	10	9	8	7	6	5	4	3	2	1	0
TMRmn (n = 1, 3)	CKS mn1	CKS mn0	0	CCS mn	SPLIT mn	STS mn2	STS mn1	STS mn0	CIS mn1	CIS mn0	0	0	MD mn3	MD mn2	MD mn1	MD mn0

Symbol	15	14	13	12	11	10	9	8	7	6	5	4	3	2	1	0
TMRmn (n = 0, 5, 7)	CKS mn1	CKS mn0	0	CCS mn	0 ^{Note}	STS mn2	STS mn1	STS mn0	CIS mn1	CIS mn0	0	0	MD mn3	MD mn2	MD mn1	MD mn0

(Bit 11 of TMRmn (n = 2, 4, 6))

MAS TER mn	Selection between using channel n independently or simultaneously with another channel(as a slave or master)														
0	Operates in independent channel operation function or as slave channel in simultaneous channel operation function.														
1	Operates as master channel in simultaneous channel operation function.														
Only the channel 2, 4, 6 can be set as a master channel (MASTERmn = 1). Be sure to use channel 0, 5, 7 are fixed to 0 (Regardless of the bit setting, channel 0 operates as master, because it is the highest channel). Clear the MASTERmn bit to 0 for a channel that is used with the independent channel operation function.															

(Bit 11 of TMRmn (n = 1, 3))

SPLI Tmn	Selection of 8 or 16-bit timer operation for channels 1 and 3														
0	Operates as 16-bit timer. (Operates in independent channel operation function or as slave channel in simultaneous channel operation function.)														
1	Operates as 8-bit timer.														

STS mn2	STS mn1	STS mn0	Setting of start trigger or capture trigger of channel n												
0	0	0	Only software trigger start is valid (other trigger sources are unselected).												
0	0	1	Valid edge of the TImn pin input is used as both the start trigger and capture trigger.												
0	1	0	Both the edges of the TImn pin input are used as a start trigger and a capture trigger.												
1	0	0	Interrupt signal of the master channel is used (when the channel is used as a slave channel with the simultaneous channel operation function).												
Other than above			Setting prohibited												

Note Bit 11 is a read-only bit and fixed to 0. Writing to this bit is ignored.

Remark m: Unit number (m = 0, 1), n: Channel number (n = 0 to 7)

Figure 6-11. Format of Timer Mode Register mn (TMRmn) (3/4)

Address: F0190H, F0191H (TMR00) to F019EH, F019FH (TMR07) After reset: 0000H R/W
 F01D0H, F01D1H (TMR10) to F01DEH, F01DFH (TMR17)

Symbol	15	14	13	12	11	10	9	8	7	6	5	4	3	2	1	0
TMRmn (n = 2, 4, 6)	CKS mn1	CKS mn0	0	CCS mn	MAST ERmn	STS mn2	STS mn1	STS mn0	CIS mn1	CIS mn0	0	0	MD mn3	MD mn2	MD mn1	MD mn0

Symbol	15	14	13	12	11	10	9	8	7	6	5	4	3	2	1	0
TMRmn (n = 1, 3)	CKS mn1	CKS mn0	0	CCS mn	SPLIT mn	STS mn2	STS mn1	STS mn0	CIS mn1	CIS mn0	0	0	MD mn3	MD mn2	MD mn1	MD mn0

Symbol	15	14	13	12	11	10	9	8	7	6	5	4	3	2	1	0
TMRmn (n = 0, 5, 7)	CKS mn1	CKS mn0	0	CCS mn	0 ^{Note}	STS mn2	STS mn1	STS mn0	CIS mn1	CIS mn0	0	0	MD mn3	MD mn2	MD mn1	MD mn0

CIS mn1	CIS mn0	Selection of TImn pin input valid edge
0	0	Falling edge
0	1	Rising edge
1	0	Both edges (when low-level width is measured) Start trigger: Falling edge, Capture trigger: Rising edge
1	1	Both edges (when high-level width is measured) Start trigger: Rising edge, Capture trigger: Falling edge
If both the edges are specified when the value of the STSmn2 to STSmn0 bits is other than 010B, set the CISmn1 to CISmn0 bits to 10B.		

Note Bit 11 is a read-only bit and fixed to 0. Writing to this bit is ignored.

Remark m: Unit number (m = 0, 1), n: Channel number (n = 0 to 7)

Figure 6-11. Format of Timer Mode Register mn (TMRmn) (4/4)

Address: F0190H, F0191H (TMR00) to F019EH, F019FH (TMR07) After reset: 0000H R/W
 F01D0H, F01D1H (TMR10) to F01DEH, F01DFH (TMR17)

Symbol	15	14	13	12	11	10	9	8	7	6	5	4	3	2	1	0
TMRmn (n = 2, 4, 6)	CKS mn1	CKS mn0	0	CCS mn	MAST ERmn	STS mn2	STS mn1	STS mn0	CIS mn1	CIS mn0	0	0	MD mn3	MD mn2	MD mn1	MD mn0

Symbol	15	14	13	12	11	10	9	8	7	6	5	4	3	2	1	0
TMRmn (n = 1, 3)	CKS mn1	CKS mn0	0	CCS mn	SPLIT mn	STS mn2	STS mn1	STS mn0	CIS mn1	CIS mn0	0	0	MD mn3	MD mn2	MD mn1	MD mn0

Symbol	15	14	13	12	11	10	9	8	7	6	5	4	3	2	1	0
TMRmn (n = 0, 5, 7)	CKS mn1	CKS mn0	0	CCS mn	0 ^{Note 1}	STS mn2	STS mn1	STS mn0	CIS mn1	CIS mn0	0	0	MD mn3	MD mn2	MD mn1	MD mn0

MD mn3	MD mn2	MD mn1	Operation mode of channel n	Corresponding function	Count operation of TCR
0	0	0	Interval timer mode	Interval timer / Square wave output / Divider function / PWM output (master)	Counting down
0	1	0	Capture mode	Input pulse interval measurement	Counting up
0	1	1	Event counter mode	External event counter	Counting down
1	0	0	One-count mode	Delay counter / One-shot pulse output / PWM output (slave)	Counting down
1	1	0	Capture & one-count mode	Measurement of high-/low-level width of input signal	Counting up

Other than above Setting prohibited
 The operation of each mode varies depending on MDmn0 bit (see the table below).

Operation mode (Value set by the MDmn3 to MDmn1 bits (see the table above))	MD mn0	Setting of starting counting and interrupt
<ul style="list-style-type: none"> Interval timer mode (0, 0, 0) Capture mode (0, 1, 0) 	0	Timer interrupt is not generated when counting is started (timer output does not change, either).
<ul style="list-style-type: none"> Event counter mode (0, 1, 1) 	0	Timer interrupt is not generated when counting is started (timer output does not change, either).
<ul style="list-style-type: none"> One-count mode^{Note 2} (1, 0, 0) 	0	Start trigger is invalid during counting operation. At that time, interrupt is not generated.
<ul style="list-style-type: none"> One-count mode^{Note 2} (1, 0, 0) 	1	Start trigger is valid during counting operation ^{Note 3} . At that time, interrupt is not generated.
<ul style="list-style-type: none"> Capture & one-count mode (1, 1, 0) 	0	Timer interrupt is not generated when counting is started (timer output does not change, either). Start trigger is invalid during counting operation. At that time interrupt is not generated.
Other than above		Setting prohibited

- Notes**
1. Bit 11 is a read-only bit and fixed to 0. Writing to this bit is ignored.
 2. In one-count mode, interrupt output (INTTMmn) when starting a count operation and TOMn output are not controlled.
 3. If the start trigger (TSMn = 1) is issued during operation, the counter is initialized, and recounting is started (does not occur the interrupt request).

Remark m: Unit number (m = 0, 1), n: Channel number (n = 0 to 7)

6.3.4 Timer status register mn (TSRmn)

The TSRmn register indicates the overflow status of the counter of channel n.

The TSRmn register is valid only in the capture mode (MDmn3 to MDmn1 = 010B) and capture & one-count mode (MDmn3 to MDmn1 = 110B). See Table 6-5 for the operation of the OVF bit in each operation mode and set/clear conditions.

The TSRmn register can be read by a 16-bit memory manipulation instruction.

The lower 8 bits of the TSRmn register can be read with an 8-bit memory manipulation instruction with TSRmnL.

Reset signal generation clears this register to 0000H.

Figure 6-12. Format of Timer Status Register mn (TSRmn)

Address: F01A0H, F01A1H (TSR00) to F01AEH, F01AFH (TSR07), After reset: 0000H R
 F01E0H, F01E1H (TSR10) to F01EEH, F01EFH (TSR17)

Symbol	15	14	13	12	11	10	9	8	7	6	5	4	3	2	1	0
TSRmn	0	0	0	0	0	0	0	0	0	0	0	0	0	0	0	OVF

OVF	Counter overflow status of channel n
0	Overflow does not occur.
1	Overflow occurs.
When OVF = 1, this flag is cleared (OVF = 0) when the next value is captured without overflow.	

Remark m: Unit number (m = 0, 1), n: Channel number (n = 0 to 7)

Table 6-5. OVF Bit Operation and Set/Clear Conditions in Each Operation Mode

Timer operation mode	OVF bit	Set/clear conditions
• Capture mode	clear	When no overflow has occurred upon capturing
• Capture & one-count mode	set	When an overflow has occurred upon capturing
• Interval timer mode	clear	— (Use prohibited)
• Event counter mode	set	
• One-count mode		

Remark The OVF bit does not change immediately after the counter has overflowed, but changes upon the subsequent capture.

6.3.5 Timer channel enable status register m (TE_m)

The TE_m register is used to enable or stop the timer operation of each channel.

Each bit of the TE_m register corresponds to each bit of the timer channel start register m (T_{Sm}) and the timer channel stop register m (T_{Tm}). When a bit of the T_{Sm} register is set to 1, the corresponding bit of this register is set to 1. When a bit of the T_{Tm} register is set to 1, the corresponding bit of this register is cleared to 0.

The TE_m register can be read by a 16-bit memory manipulation instruction.

The lower 8 bits of the TE_m register can be set with a 1-bit or 8-bit memory manipulation instruction with TE_{mL}.

Reset signal generation clears this register to 0000H.

Figure 6-13. Format of Timer Channel Enable Status register m (TE_m)

Address: F01B0H, F01B1H (TE₀), F01F0H, F01F1H (TE₁) After reset: 0000H R

Symbol	15	14	13	12	11	10	9	8	7	6	5	4	3	2	1	0
TE _m	0	0	0	0	TEH _{m3} 3	0	TEH _{m1} 1	0	TE _{m7} 7	TE _{m6} 6	TE _{m5} 5	TE _{m4} 4	TE _{m3} 3	TE _{m2} 2	TE _{m1} 1	TE _{m0} 0

TEH _{m3}	Indication of whether operation of the higher 8-bit timer is enabled or stopped when channel 3 is in the 8-bit timer mode
0	Operation is stopped.
1	Operation is enabled.

TEH _{m1}	Indication of whether operation of the higher 8-bit timer is enabled or stopped when channel 1 is in the 8-bit timer mode
0	Operation is stopped.
1	Operation is enabled.

TE _m _n	Indication of operation enable/stop status of channel n
0	Operation is stopped.
1	Operation is enabled.
This bit displays whether operation of the lower 8-bit timer for TE _{m1} and TE _{m3} is enabled or stopped when channel 1 or 3 is in the 8-bit timer mode.	

Remark m: Unit number (m = 0, 1), n: Channel number (n = 0 to 7)

6.3.6 Timer channel start register m (TSm)

The TSm register is a trigger register that is used to initialize timer count register mn (TCRmn) and start the counting operation of each channel.

When a bit of this register is set to 1, the corresponding bit of timer channel enable status register m (TEm) is set to 1. The TSmn, TSHm1, TSHm3 bits are immediately cleared when operation is enabled (TEmn, TEHm1, TEHm3 = 1), because they are trigger bits.

The TSm register can be set by a 16-bit memory manipulation instruction.

The lower 8 bits of the TSm register can be set with a 1-bit or 8-bit memory manipulation instruction with TSmL.

Reset signal generation clears this register to 0000H.

Figure 6-14. Format of Timer Channel Start register m (TSm)

Address: F01B2H, F01B3H (TS0), F01F2H, F01F3H (TS1) After reset: 0000H R/W

Symbol	15	14	13	12	11	10	9	8	7	6	5	4	3	2	1	0
TSm	0	0	0	0	TSHm 3	0	TSHm 1	0	TSm 7	TSm 6	TSm 5	TSm 4	TSm 3	TSm 2	TSm 1	TSm 0

TSHm3	Trigger to enable operation (start operation) of the higher 8-bit timer when channel 3 is in the 8-bit timer mode
0	No trigger operation
1	The TEHm3 bit is set to 1 and the count operation becomes enabled. The TCRm3 register count operation start in the interval timer mode in the count operation enabled state (see Table 6-6 in 6.5.2 Start timing of counter).

TSHm1	Trigger to enable operation (start operation) of the higher 8-bit timer when channel 1 is in the 8-bit timer mode
0	No trigger operation
1	The TEHm1 bit is set to 1 and the count operation becomes enabled. The TCRm1 register count operation start in the interval timer mode in the count operation enabled state (see Table 6-6 in 6.5.2 Start timing of counter).

TSmn	Operation enable (start) trigger of channel n
0	No trigger operation
1	The TEMn bit is set to 1 and the count operation becomes enabled. The TCRmn register count operation start in the count operation enabled state varies depending on each operation mode (see Table 6-6 in 6.5.2 Start timing of counter). This bit is the trigger to enable operation (start operation) of the lower 8-bit timer for TSm1 and TSm3 when channel 1 or 3 is in the 8-bit timer mode.

- Cautions**
1. Be sure to clear bits 15 to 12, 10, and 8 to 0.
 2. When switching from a function that does not use TImn pin input to one that does, the following wait period is required from when timer mode register mn (TMRmn) is set until the TSmn (TSHm1, TSHm3) bit is set to 1.
 - When the TImn pin noise filter is enabled (TNFENnm = 1): Four cycles of the operation clock (f_{MCK})
 - When the TImn pin noise filter is disabled (TNFENnm = 0): Two cycles of the operation clock (f_{MCK})

- Remarks**
1. When the TSm register is read, 0 is always read.
 2. m: Unit number (m = 0, 1), n: Channel number (n = 0 to 7)

6.3.7 Timer channel stop register m (TTm)

The TTm register is a trigger register that is used to stop the counting operation of each channel.

When a bit of this register is set to 1, the corresponding bit of timer channel enable status register m (TEm) is cleared to 0. The TTmn, TTHm1, TTHm3 bits are immediately cleared when operation is stopped (TEmn, TEHm1, TEHm3 = 0), because they are trigger bits.

The TTm register can be set by a 16-bit memory manipulation instruction.

The lower 8 bits of the TTm register can be set with a 1-bit or 8-bit memory manipulation instruction with TTmL.

Reset signal generation clears this register to 0000H.

Figure 6-15. Format of Timer Channel Stop register m (TTm)

Address: F01B4H, F01B5H After reset: 0000H R/W

Symbol	15	14	13	12	11	10	9	8	7	6	5	4	3	2	1	0
TTm	0	0	0	0	TTHm 3	0	TTHm 1	0	TTm 7	TTm 6	TTm 5	TTm 4	TTm 3	TTm 2	TTm 1	TTm 0

TTHm3	Trigger to stop operation of the higher 8-bit timer when channel 3 is in the 8-bit timer mode
0	No trigger operation
1	TEHm3 bit is cleared to 0 and the count operation is stopped.

TTHm1	Trigger to stop operation of the higher 8-bit timer when channel 1 is in the 8-bit timer mode
0	No trigger operation
1	TEHm1 bit is cleared to 0 and the count operation is stopped.

TTm n	Operation stop trigger of channel n
0	No trigger operation
1	TEmn bit is cleared to 0 and the count operation is stopped. The TTm1 and TTm3 bits respectively trigger stoppage of operation of the lower 8-bit timers in channels 1 and 3 when these channels are in the 8-bit timer mode.

Caution Be sure to clear bits 15 to 12, 10, and 8 of the TTm register to 0.

- Remarks 1.** When the TTm register is read, 0 is always read.
2. m: Unit number (m = 0, 1), n: Channel number (n = 0 to 7)

6.3.8 Timer input select register 0 (TIS0)

The TIS0 register is used to select the channel 5 of unit 0 timer input.
 The TIS0 register can be set by an 8-bit memory manipulation instruction.
 Reset signal generation clears this register to 00H.

Figure 6-16. Format of Timer Input Select register 0 (TIS0)

Address: F0074H After reset: 00H R/W

Symbol	7	6	5	4	3	2	1	0
TIS0	0	0	0	0	0	TIS02	TIS01	TIS00

TIS02	TIS01	TIS00	Selection of timer input used with channel 5
0	0	0	Input signal of timer input pin (TI05)
0	0	1	
0	1	0	
0	1	1	
1	0	0	Low-speed on-chip oscillator clock (f _{IL})
1	0	1	Subsystem clock (f _{SUB})
Other than above			Setting prohibited

Caution High-level width, low-level width of timer input is selected, will require more than 1/f_{MCK} +10 ns.
 Therefore, when selecting f_{SUB} to f_{CLK} (CSS bit of CKC register = 1), can not TIS02 bit set to 1.

6.3.9 Timer output enable register m (TOEm)

The TOEm register is used to enable or disable timer output of each channel.

Channel n for which timer output has been enabled becomes unable to rewrite the value of the TOMn bit of timer output register m (TOM) described later by software, and the value reflecting the setting of the timer output function through the count operation is output from the timer output pin (TOMn).

The TOEm register can be set by a 16-bit memory manipulation instruction.

The lower 8 bits of the TOEm register can be set with a 1-bit or 8-bit memory manipulation instruction with TOEmL.

Reset signal generation clears this register to 0000H.

Figure 6-17. Format of Timer Output Enable register m (TOEm)

Address: F01BAH, F01BBH (TOE0), F01FAH, F01FBH (TOE1) After reset: 0000H R/W

Symbol	15	14	13	12	11	10	9	8	7	6	5	4	3	2	1	0
TOEm	0	0	0	0	0	0	0	0	TOE m7	TOE m6	TOE m5	TOE m4	TOE m3	TOE m2	TOE m1	TOE m0

TOE mn	Timer output enable/disable of channel n
0	Disable output of timer. Without reflecting on TOMn bit timer operation, to fixed the output. Writing to the TOMn bit is enabled and the level set in the TOMn bit is output from the TOMn pin.
1	Enable output of timer. Reflected in the TOMn bit timer operation, to generate the output waveform. Writing to the TOMn bit is disabled (writing is ignored).

Caution Be sure to clear bits 15 to 8 to 0.

Remark m: Unit number (m = 0, 1), n: Channel number (n = 0 to 7)

6.3.10 Timer output register m (T_{Om})

The T_{Om} register is a buffer register of timer output of each channel.

The value of each bit in this register is output from the timer output pin (T_{Om}_n) of each channel.

The T_{Om}_n bit on this register can be rewritten by software only when timer output is disabled (TOE_m_n = 0). When timer output is enabled (TOE_m_n = 1), rewriting this register by software is ignored, and the value is changed only by the timer operation.

To use the P00/TI00, P01/TO00, P16/TI01/TO01, P17/TI02/TO02, P31/TI03/TO03, P42/TI04/TO04, P46/TI05/TO05, P102/TI06/TO06, P145/TI07/TO07, P64/TI10/TO10, P65/TI11/TO11, P66/TI12/TO12, P67/TI13/TO13, P103/TI14/TO14, P104/TI15/TO15, P105/TI16/TO16, or P106/TI17/TO17 pin as a port function pin, set the corresponding T_{Om}_n bit to “0”.

The T_{Om} register can be set by a 16-bit memory manipulation instruction.

The lower 8 bits of the T_{Om} register can be set with an 8-bit memory manipulation instruction with T_{Om}L.

Reset signal generation clears this register to 0000H.

Figure 6-18. Format of Timer Output register m (T_{Om})

Address: F01B8H, F01B9H (TO0), F01F8H, F01F9H (TO1) After reset: 0000H R/W

Symbol	15	14	13	12	11	10	9	8	7	6	5	4	3	2	1	0
T _{Om}	0	0	0	0	0	0	0	0	T _{Om} ₇	T _{Om} ₆	T _{Om} ₅	T _{Om} ₄	T _{Om} ₃	T _{Om} ₂	T _{Om} ₁	T _{Om} ₀

T _{Om} _n	Timer output of channel n
0	Timer output value is “0”.
1	Timer output value is “1”.

Caution Be sure to clear bits 15 to 8 to 0.

Remark m: Unit number (m = 0, 1), n: Channel number (n = 0 to 7)

6.3.11 Timer output level register m (TOLm)

The TOLm register is a register that controls the timer output level of each channel.

The setting of the inverted output of channel n by this register is reflected at the timing of set or reset of the timer output signal while the timer output is enabled (TOEmn = 1) in the Slave channel output mode (TOMmn = 1). In the master channel output mode (TOMmn = 0), this register setting is invalid.

The TOLm register can be set by a 16-bit memory manipulation instruction.

The lower 8 bits of the TOLm register can be set with an 8-bit memory manipulation instruction with TOLmL.

Reset signal generation clears this register to 0000H.

Figure 6-19. Format of Timer Output Level register m (TOLm)

Address: F01BCH, F01BDH (TOL0), F01FCH, F01FDH (TOL1) After reset: 0000H R/W

Symbol	15	14	13	12	11	10	9	8	7	6	5	4	3	2	1	0
TOLm	0	0	0	0	0	0	0	0	TOL m7	TOL m6	TOL m5	TOL m4	TOL m3	TOL m2	TOL m1	0

TOL mn	Control of timer output level of channel n
0	Positive logic output (active-high)
1	Negative logic output (active-low)

Caution Be sure to clear bits 15 to 8, and 0 to 0.

- Remarks 1.** If the value of this register is rewritten during timer operation, the timer output logic is inverted when the timer output signal changes next, instead of immediately after the register value is rewritten.
- 2.** m: Unit number (m = 0, 1), n: Channel number (n = 0 to 7)

6.3.12 Timer output mode register m (TOMm)

The TOMm register is used to control the timer output mode of each channel.

When a channel is used for the independent channel operation function, set the corresponding bit of the channel to be used to 0.

When a channel is used for the simultaneous channel operation function (PWM output, one-shot pulse output, or multiple PWM output), set the corresponding bit of the master channel to 0 and the corresponding bit of the slave channel to 1.

The setting of each channel n by this register is reflected at the timing when the timer output signal is set or reset while the timer output is enabled (TOEmn = 1).

The TOMm register can be set by a 16-bit memory manipulation instruction.

The lower 8 bits of the TOMm register can be set with an 8-bit memory manipulation instruction with TOMmL.

Reset signal generation clears this register to 0000H.

Figure 6-20. Format of Timer Output Mode register m (TOMm)

Address: F01BEH, F01BFH (TOM0), F01FEH, F01FFH (TOM1) After reset: 0000H R/W

Symbol	15	14	13	12	11	10	9	8	7	6	5	4	3	2	1	0
TOMm	0	0	0	0	0	0	0	0	TOM m7	TOM m6	TOM m5	TOM m4	TOM m3	TOM m2	TOM m1	0

TOM mn	Control of timer output mode of channel n
0	Master channel output mode (to produce toggle output by timer interrupt request signal (INTTMmn))
1	Slave channel output mode (output is set by the timer interrupt request signal (INTTMmn) of the master channel, and reset by the timer interrupt request signal (INTTM0p) of the slave channel)

Caution Be sure to clear bits 15 to 8, and 0 to 0.

Remark m: Unit number (m = 0, 1)
 n: Channel number
 n = 0 to 7 (n = 0, 2, 4, 6 for master channel)
 p: Slave channel number
 n < p ≤ 7
 (For details of the relation between the master channel and slave channel, refer to **6.4.1 Basic rules of simultaneous channel operation function.**)

6.3.13 Input switch control register (ISC)

The ISC1 and ISC0 bits of the ISC register are used to implement LIN-bus communication operation by using channel 7 in association with the serial array unit. When the ISC1 bit is set to 1, the input signal of the serial data input pin (RxD2) is selected as a timer input signal.

The ISC register can be set by a 1-bit or 8-bit memory manipulation instruction.

Reset signal generation clears this register to 00H.

Figure 6-21. Format of Input Switch Control Register (ISC)

Address: F0073H After reset: 00H R/W

Symbol	7	6	5	4	3	2	1	0
ISC	0	0	0	0	0	0	ISC1	ISC0

ISC1	Switching channel 7 input of timer array unit
0	30, 32, 36, 40, 44, 48, 52, 64, 80, 100, and 128-pin products: Uses the input signal of the TI07 pin as a timer input (normal operation). 20, 24, 25-pin products: Do not use a timer input signal for channel 7.
1	Input signal of the RxD2 pin is used as timer input (detects the wakeup signal and measures the low width of the break field and the pulse width of the sync field). Setting is prohibited in the 20, 24, and 25-pin products.

ISC0	Switching external interrupt (INTP0) input
0	Uses the input signal of the INTP0 pin as an external interrupt (normal operation).
1	Uses the input signal of the RxD2 pin as an external interrupt (wakeup signal detection).

Caution Be sure to clear bits 7 to 2 to 0.

Remark When the LIN-bus communication function is used, select the input signal of the RxD2 pin by setting ISC1 to 1.

6.3.14 Noise filter enable registers 1, 2 (NFEN1, NFEN2)

The NFEN1 and NFEN2 registers are used to set whether the noise filter can be used for the timer input signal to each channel.

Enable the noise filter by setting the corresponding bits to 1 on the pins in need of noise removal.

When the noise filter is enabled, after synchronization with the operating clock (f_{MCK}) for the target channel, whether the signal keeps the same value for two clock cycles is detected.

When the noise filter is disabled, the input signal is only synchronized with the operating clock (f_{MCK}) for the target channel ^{Note}.

The NFEN1 and NFEN2 registers can be set by a 1-bit or 8-bit memory manipulation instruction.

Reset signal generation clears this register to 00H.

Note For details, see **6.5.1 (2) When valid edge of input signal via the TImn pin is selected (CCSmn = 1)**, **6.5.2 Start timing of counter**, and **6.7 Timer Input (TImn) Control**.

Figure 6-22. Format of Noise Filter Enable Registers 1, 2 (NFEN1, NFEN2) (1/2)

Address: F0071H After reset: 00H R/W

Symbol	7	6	5	4	3	2	1	0
NFEN1	TNFEN07	TNFEN06	TNFEN05	TNFEN04	TNFEN03	TNFEN02	TNFEN01	TNFEN00

Address: F0072H After reset: 00H R/W

Symbol	7	6	5	4	3	2	1	0
NFEN2	TNFEN17	TNFEN16	TNFEN15	TNFEN14	TNFEN13	TNFEN12	TNFEN11	TNFEN10

TNFEN07	Enable/disable using noise filter of TI07 pin ^{Note}
0	Noise filter OFF
1	Noise filter ON

TNFEN06	Enable/disable using noise filter of TI06 pin
0	Noise filter OFF
1	Noise filter ON

TNFEN05	Enable/disable using noise filter of TI05 pin
0	Noise filter OFF
1	Noise filter ON

TNFEN04	Enable/disable using noise filter of TI04 pin
0	Noise filter OFF
1	Noise filter ON

TNFEN03	Enable/disable using noise filter of TI03 pin
0	Noise filter OFF
1	Noise filter ON

TNFEN02	Enable/disable using noise filter of TI02 pin
0	Noise filter OFF
1	Noise filter ON

TNFEN01	Enable/disable using noise filter of TI01 pin
0	Noise filter OFF
1	Noise filter ON

TNFEN00	Enable/disable using noise filter of TI00 pin
0	Noise filter OFF
1	Noise filter ON

Note The applicable pin can be switched by setting the ISC1 bit of the ISC register.
 ISC1 = 0: Whether or not to use the noise filter of the TI07 pin can be selected.
 ISC1 = 1: Whether or not to use the noise filter of the RxD2 pin can be selected.

Remark The presence or absence of timer I/O pins of channel 0 to 7 depends on the product. See **Table 6-2 Timer I/O Pins provided in Each Product** for details.

Figure 6-22. Format of Noise Filter Enable Registers 1, 2 (NFEN1, NFEN2) (2/2)

Address: F0071H After reset: 00H R/W

Symbol	7	6	5	4	3	2	1	0
NFEN1	TNFEN07	TNFEN06	TNFEN05	TNFEN04	TNFEN03	TNFEN02	TNFEN01	TNFEN00

Address: F0072H After reset: 00H R/W

Symbol	7	6	5	4	3	2	1	0
NFEN2	TNFEN17	TNFEN16	TNFEN15	TNFEN14	TNFEN13	TNFEN12	TNFEN11	TNFEN10

TNFEN17	Enable/disable using noise filter of TI17 pin
0	Noise filter OFF
1	Noise filter ON

TNFEN16	Enable/disable using noise filter of TI16 pin
0	Noise filter OFF
1	Noise filter ON

TNFEN15	Enable/disable using noise filter of TI15 pin
0	Noise filter OFF
1	Noise filter ON

TNFEN14	Enable/disable using noise filter of TI14 pin
0	Noise filter OFF
1	Noise filter ON

TNFEN13	Enable/disable using noise filter of TI13 pin
0	Noise filter OFF
1	Noise filter ON

TNFEN12	Enable/disable using noise filter of TI12 pin
0	Noise filter OFF
1	Noise filter ON

TNFEN11	Enable/disable using noise filter of TI11 pin
0	Noise filter OFF
1	Noise filter ON

TNFEN10	Enable/disable using noise filter of TI00 pin
0	Noise filter OFF
1	Noise filter ON

Remark The presence or absence of timer I/O pins of channel 0 to 7 depends on the product. See **Table 6-2 Timer I/O Pins provided in Each Product** for details.

6.3.15 Registers controlling port functions of pins to be used for timer I/O

Using port pins for the timer array unit functions requires setting of the registers that control the port functions multiplexed on the target pins (port mode register (PMxx), port register (Pxx), and port mode control register (PMCxx)). For details, see **4.3.1 Port mode registers (PMxx)**, **4.3.2 Port registers (Pxx)**, and **4.3.6 Port mode control registers (PMCxx)**.

The port mode register (PMxx), port register (Pxx), and port mode control register (PMCxx) to be set depend on the product. For details, see **4.5.3 Register setting examples for used port and alternate functions**.

When using the ports (such as P00/TI00 and P01/TO00) to be shared with the timer output pin for timer output, set the port mode control register (PMCxx) bit, port mode register (PMxx) bit and port register (Pxx) bit corresponding to each port to 0.

Example: When using P01/TO00 for timer output

Set the PMC01 bit of port mode control register 0 to 0.

Set the PM01 bit of port mode register 0 to 0.

Set the P01 bit of port register 0 to 0.

When using the ports (such as P00/TI00) to be shared with the timer input pin for timer input, set the port mode register (PMxx) bit corresponding to each port to 1. And set the port mode control register (PMCxx) bit corresponding to each port to 0. At this time, the port register (Pxx) bit may be 0 or 1.

Example: When using P00/TI00 for timer input

Set the PMC00 bit of port mode control register 0 to 0.

Set the PM00 bit of port mode register 0 to 1.

Set the P00 bit of port register 0 to 0 or 1.

6.4 Basic Rules of Timer Array Unit

6.4.1 Basic rules of simultaneous channel operation function

When simultaneously using multiple channels, namely, a combination of a master channel (a reference timer mainly counting the cycle) and slave channels (timers operating according to the master channel), the following rules apply.

- (1) Only an even channel (channel 0, 2, 4, etc.) can be set as a master channel.
- (2) Any channel, except channel 0, can be set as a slave channel.
- (3) The slave channel must be lower than the master channel.

Example: If channel 2 is set as a master channel, channel 3 or those that follow (channels 3, 4, 5, etc.) can be set as a slave channel.

- (4) Two or more slave channels can be set for one master channel.
- (5) When two or more master channels are to be used, slave channels with a master channel between them may not be set.

Example: If channels 0 and 4 are set as master channels, channels 1 to 3 can be set as the slave channels of master channel 0. Channels 5 to 7 cannot be set as the slave channels of master channel 0.

- (6) The operating clock for a slave channel in combination with a master channel must be the same as that of the master channel. The CKSmn0, CKSmn1 bits (bit 15, 14 of timer mode register mn (TMRmn)) of the slave channel that operates in combination with the master channel must be the same value as that of the master channel.
- (7) A master channel can transmit INTTMmn (interrupt), start software trigger, and count clock to the lower channels.
- (8) A slave channel can use INTTMmn (interrupt), a start software trigger, or the count clock of the master channel as a source clock, but cannot transmit its own INTTMmn (interrupt), start software trigger, or count clock to channels with lower channel numbers.
- (9) A master channel cannot use INTTMmn (interrupt), a start software trigger, or the count clock from the other higher master channel as a source clock.
- (10) To simultaneously start channels that operate in combination, the channel start trigger bit (TSmn) of the channels in combination must be set at the same time.
- (11) During the counting operation, a TSmn bit of a master channel or TSmn bits of all channels which are operating simultaneously can be set. It cannot be applied to TSmn bits of slave channels alone.
- (12) To stop the channels in combination simultaneously, the channel stop trigger bit (TTmn) of the channels in combination must be set at the same time.
- (13) CKm2/CKm3 cannot be selected while channels are operating simultaneously, because the operating clocks of master channels and slave channels have to be synchronized.
- (14) Timer mode register m0 (TMRm0) has no master bit (it is fixed as "0"). However, as channel 0 is the highest channel, it can be used as a master channel during simultaneous operation.

The rules of the simultaneous channel operation function are applied in a channel group (a master channel and slave channels forming one simultaneous channel operation function).

If two or more channel groups that do not operate in combination are specified, the basic rules of the simultaneous channel operation function in **6.4.1 Basic rules of simultaneous channel operation function** do not apply to the channel groups.

Remark m: Unit number (m = 0, 1), n: Channel number (n = 0 to 7)

Example

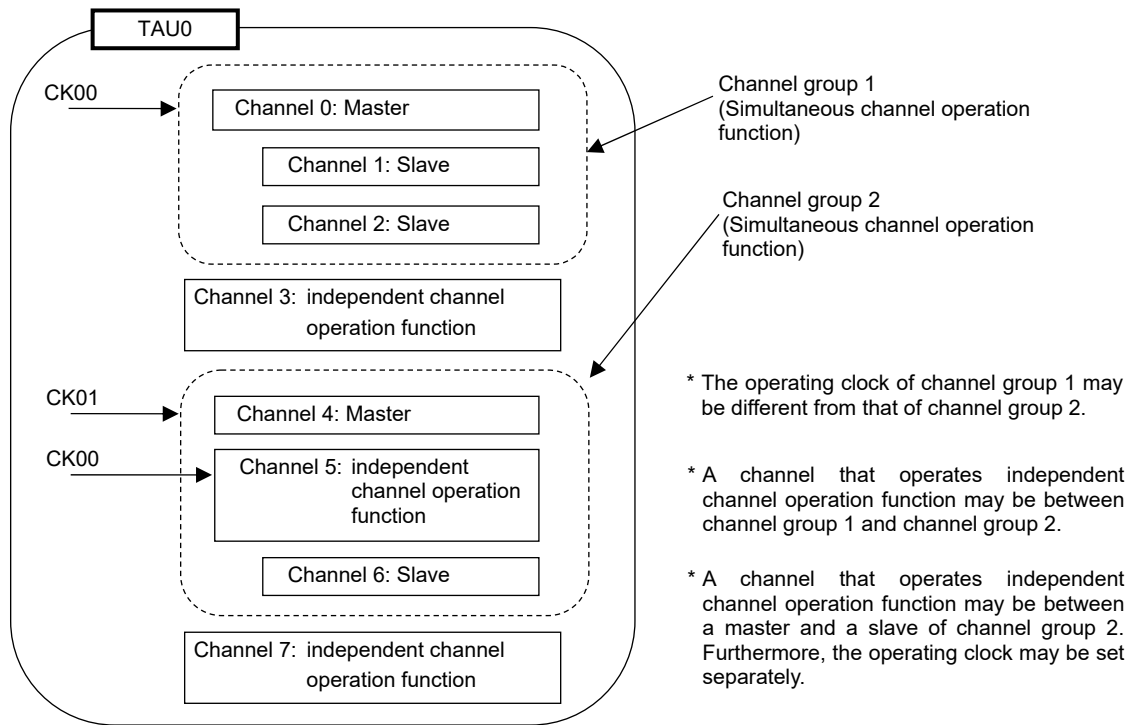

6.4.2 Basic rules of 8-bit timer operation function (channels 1 and 3 only)

The 8-bit timer operation function makes it possible to use a 16-bit timer channel in a configuration consisting of two 8-bit timer channels.

This function can only be used for channels 1 and 3, and there are several rules for using it.

The basic rules for this function are as follows:

- (1) The 8-bit timer operation function applies only to channels 1 and 3.
- (2) When using 8-bit timers, set the SPLIT_{mn} bit of timer mode register *mn* (TMR_{mn}) to 1.
- (3) The higher 8 bits can be operated as the interval timer function.
- (4) At the start of operation, the higher 8 bits output INTT_{m1H}/INTT_{m3H} (an interrupt) (which is the same operation performed when MD_{mn0} is set to 1).
- (5) The operation clock of the higher 8 bits is selected according to the CKS_{mn1} and CKS_{mn0} bits of the lower-bit TMR_{mn} register.
- (6) For the higher 8 bits, the TSH_{m1}/TSH_{m3} bit is manipulated to start channel operation and the TTH_{m1}/TTH_{m3} bit is manipulated to stop channel operation. The channel status can be checked using the TEH_{m1}/TEH_{m3} bit.
- (7) The lower 8 bits operate according to the TMR_{mn} register settings. The following three functions support operation of the lower 8 bits:
 - Interval timer function/ Square Wave Output Function
 - External event counter function
 - Delay count function
- (8) For the lower 8 bits, the TSm₁/TSm₃ bit is manipulated to start channel operation and the TTm₁/TTm₃ bit is manipulated to stop channel operation. The channel status can be checked using the TEM₁/TEM₃ bit.
- (9) During 16-bit operation, manipulating the TSH_{m1}, TSH_{m3}, TTH_{m1}, and TTH_{m3} bits is invalid. The TSm₁, TSm₃, TTm₁, and TTm₃ bits are manipulated to operate channels 1 and 3. The TEH_{m3} and TEH_{m1} bits are not changed.
- (10) For the 8-bit timer function, the simultaneous operation functions (one-shot pulse, PWM, and multiple PWM) cannot be used.

Remark m: Unit number (m = 0, 1), n: Channel number (n = 1, 3)

6.5 Operation of Counter

6.5.1 Count clock (f_{CLK})

The count clock (f_{CLK}) of the timer array unit can be selected between following by CCS_{mn} bit of timer mode register mn (TMR_{mn}).

- Operation clock (f_{MCK}) specified by the CKS_{mn0} and CKS_{mn1} bits
- Valid edge of input signal input from the TIM_n pin

Because the timer array unit is designed to operate in synchronization with f_{CLK}, the timings of the count clock (f_{CLK}) are shown below.

(1) When operation clock (f_{MCK}) specified by the CKS_{mn0} and CKS_{mn1} bits is selected (CCS_{mn} = 0)

The count clock (f_{CLK}) is between f_{CLK} to f_{CLK} / 2¹⁵ by setting of timer clock select register m (TPS_m). When a divided f_{CLK} is selected, however, the clock selected in TPS_m register, but a signal which becomes high level for one period of f_{CLK} from its rising edge. When a f_{CLK} is selected, fixed to high level

Counting of timer count register mn (TCR_{mn}) delayed by one period of f_{CLK} from rising edge of the count clock, because of synchronization with f_{CLK}. But, this is described as “counting at rising edge of the count clock”, as a matter of convenience.

Figure 6-23. Timing of f_{CLK} and count clock (f_{CLK}) (When CCS_{mn} = 0)

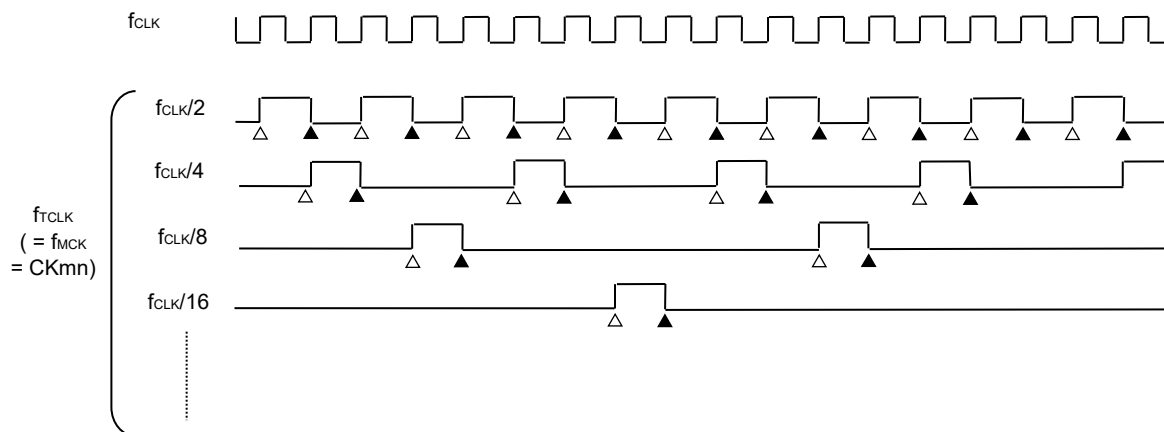

- Remarks 1.** Δ : Rising edge of the count clock
 ▲ : Synchronization, increment/decrement of counter
- 2.** f_{CLK}: CPU/peripheral hardware clock

(2) When valid edge of input signal via the TImn pin is selected (CCSmn = 1)

The count clock (f_{TCLK}) becomes the signal that detects valid edge of input signal via the TImn pin and synchronizes next rising f_{MCK} . The count clock (f_{TCLK}) is delayed for 1 to 2 period of f_{MCK} from the input signal via the TImn pin (when a noise filter is used, the delay becomes 3 to 4 clock).

Counting of timer count register mn (TCRmn) delayed by one period of f_{CLK} from rising edge of the count clock, because of synchronization with f_{CLK} . But, this is described as “counting at valid edge of input signal via the TImn pin”, as a matter of convenience.

Figure 6-24. Timing of f_{CLK} and count clock (f_{TCLK}) (When CCSmn = 1, noise filter unused)

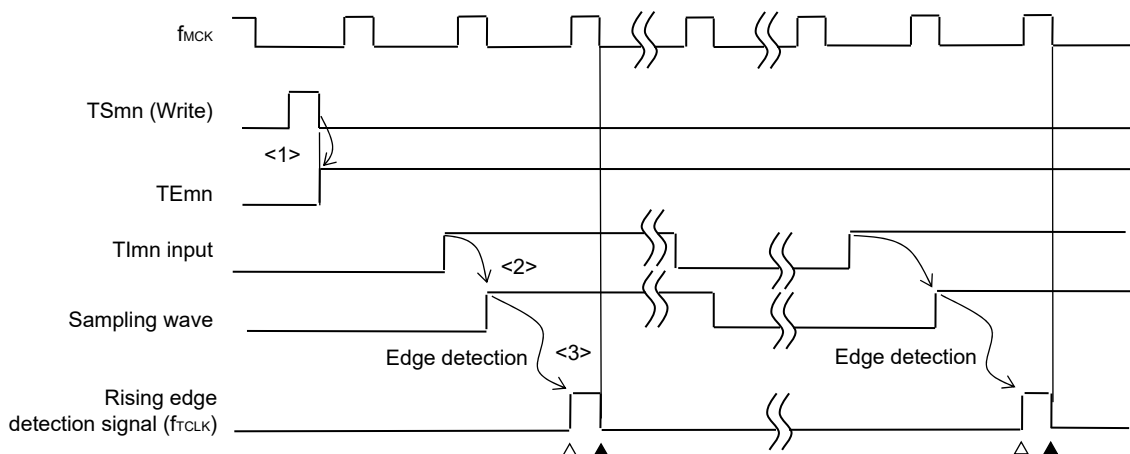

- <1> Setting TSmn bit to 1 enables the timer to be started and to become wait state for valid edge of input signal via the TImn pin.
- <2> The rise of input signal via the TImn pin is sampled by f_{MCK} .
- <3> The edge is detected by the rising of the sampled signal and the detection signal (count clock) is output.

- Remarks 1.** Δ : Rising edge of the count clock
 \blacktriangle : Synchronization, increment/decrement of counter
2. f_{CLK} : CPU/peripheral hardware clock
 f_{MCK} : Operation clock of channel n
 3. The waveform of the input signal via TImn pin of the input pulse interval measurement, the measurement of high/low width of input signal, and the delay counter, the one-shot pulse output are the same.

6.5.2 Start timing of counter

Timer count register mn (TCRmn) becomes enabled to operation by setting of TSmn bit of timer channel start register m (TSm).

Operations from count operation enabled state to timer count Register mn (TCRmn) count start is shown in Table 6-6.

Table 6-6. Operations from Count Operation Enabled State to Timer count Register mn (TCRmn) Count Start

Timer operation mode	Operation when TSmn = 1 is set
<ul style="list-style-type: none"> Interval timer mode 	<p>No operation is carried out from start trigger detection (TSmn=1) until count clock generation.</p> <p>The first count clock loads the value of the TDRmn register to the TCRmn register and the subsequent count clock performs count down operation (see 6.5.3 (1) Operation of interval timer mode).</p>
<ul style="list-style-type: none"> Event counter mode 	<p>Writing 1 to the TSmn bit loads the value of the TDRmn register to the TCRmn register.</p> <p>If detect edge of TImn input. The subsequent count clock performs count down operation (see 6.5.3 (2) Operation of event counter mode).</p>
<ul style="list-style-type: none"> Capture mode 	<p>No operation is carried out from start trigger detection (TSmn = 1) until count clock generation.</p> <p>The first count clock loads 0000H to the TCRmn register and the subsequent count clock performs count up operation (see 6.5.3 (3) Operation of capture mode (input pulse interval measurement)).</p>
<ul style="list-style-type: none"> One-count mode 	<p>The waiting-for-start-trigger state is entered by writing 1 to the TSmn bit while the timer is stopped (TEmn = 0).</p> <p>No operation is carried out from start trigger detection until count clock generation.</p> <p>The first count clock loads the value of the TDRmn register to the TCRmn register and the subsequent count clock performs count down operation (see 6.5.3 (4) Operation of one-count mode).</p>
<ul style="list-style-type: none"> Capture & one-count mode 	<p>The waiting-for-start-trigger state is entered by writing 1 to the TSmn bit while the timer is stopped (TEmn = 0).</p> <p>No operation is carried out from start trigger detection until count clock generation.</p> <p>The first count clock loads 0000H to the TCRmn register and the subsequent count clock performs count up operation (see 6.5.3 (5) Operation of capture & one-count mode (high-level interval measurement)).</p>

6.5.3 Operation of counter

Here, the counter operation in each mode is explained.

(1) Operation of interval timer mode

- <1> Operation is enabled ($TE_{mn} = 1$) by writing 1 to the TS_{mn} bit. Timer count register mn (TCR_{mn}) holds the initial value until count clock generation.
- <2> A start trigger is generated at the first count clock after operation is enabled.
- <3> When the MD_{mn0} bit is set to 1, $INTT_{mn}$ is generated by the start trigger.
- <4> By the first count clock after the operation enable, the value of timer data register mn (TDR_{mn}) is loaded to the TCR_{mn} register and counting starts in the interval timer mode.
- <5> When the TCR_{mn} register counts down and its count value is 0000H, $INTT_{mn}$ is generated and the value of timer data register mn (TDR_{mn}) is loaded to the TCR_{mn} register and counting keeps on.

Figure 6-25. Operation Timing (In Interval Timer Mode)

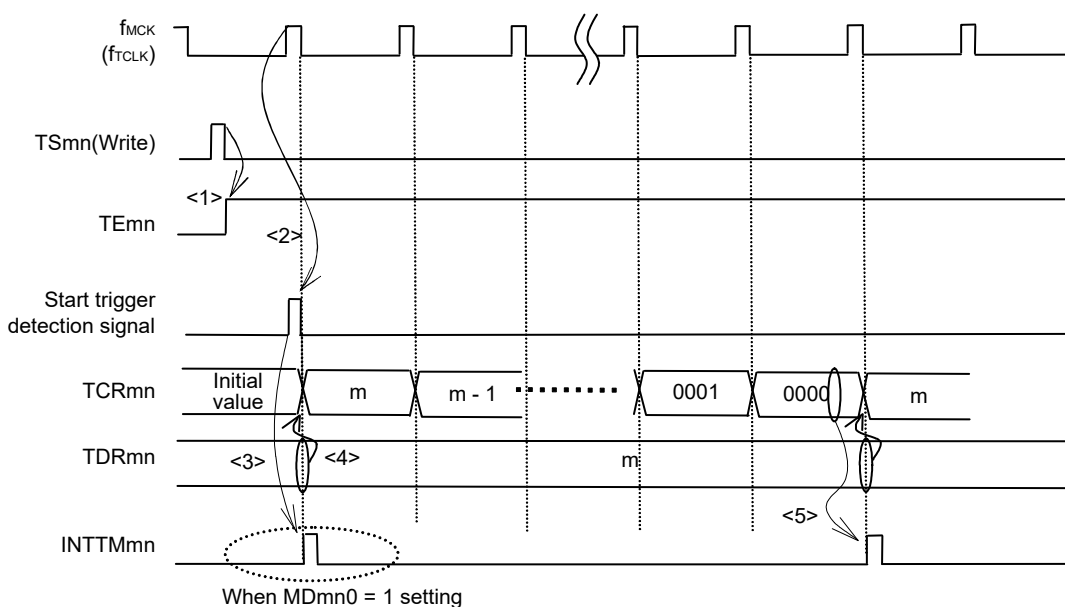

Caution In the first cycle operation of count clock after writing the TS_{mn} bit, an error at a maximum of one clock is generated since count start delays until count clock has been generated. When the information on count start timing is necessary, an interrupt can be generated at count start by setting $MD_{mn0} = 1$.

Remark f_{MCK} , the start trigger detection signal, and $INTT_{mn}$ become active between one clock in synchronization with f_{CLK} .

(2) Operation of event counter mode

- <1> Timer count register mn (TCRmn) holds its initial value while operation is stopped (TEmn = 0).
- <2> Operation is enabled (TEmn = 1) by writing 1 to the TSmn bit.
- <3> As soon as 1 has been written to the TSmn bit and 1 has been set to the TEmn bit, the value of timer data register mn (TDRmn) is loaded to the TCRmn register to start counting.
- <4> After that, the TCRmn register value is counted down according to the count clock of the valid edge of the TImn input .

Figure 6-26. Operation Timing (In Event Counter Mode)

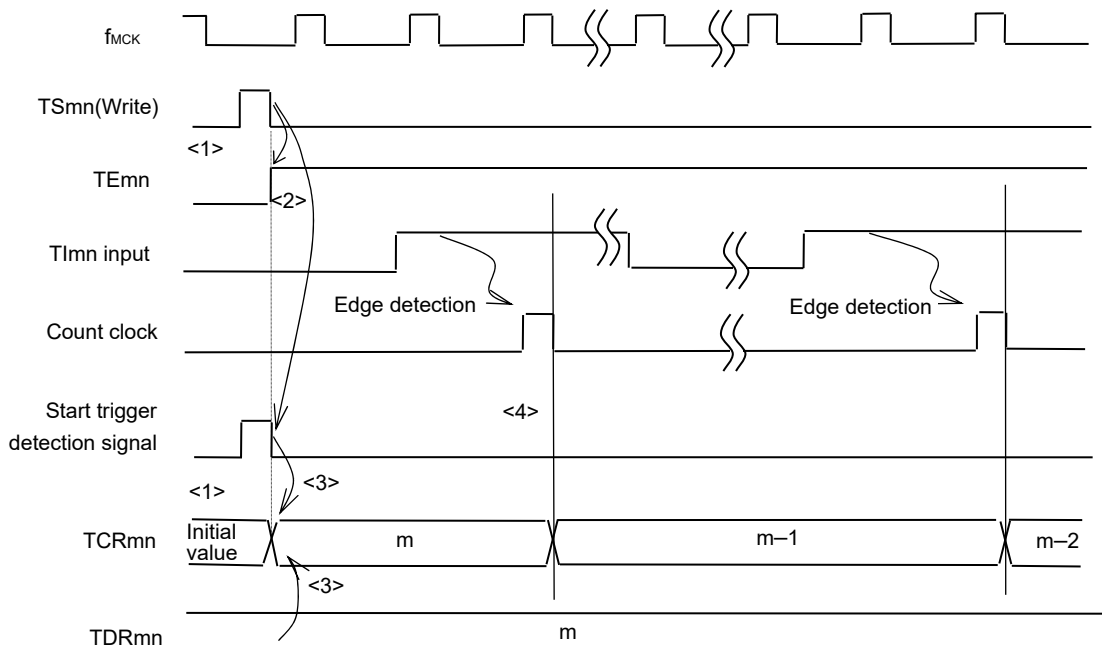

Remark Figure 6-26 shows the timing when the noise filter is not used. By making the noise filter on-state, the edge detection becomes 2 f_{MCK} cycles (it sums up to 3 to 4 cycles) later than the normal cycle of TImn input. The error per one period occurs because of the asynchronous between the period of the TImn input and that of the count clock (f_{MCK}).

(3) Operation of capture mode (input pulse interval measurement)

- <1> Operation is enabled ($TE_{mn} = 1$) by writing 1 to the TS_{mn} bit.
- <2> Timer count register mn (TCR_{mn}) holds the initial value until count clock generation.
- <3> A start trigger is generated at the first count clock after operation is enabled. And the value of 0000H is loaded to the TCR_{mn} register and counting starts in the capture mode. (When the MD_{mn0} bit is set to 1, $INTTM_{mn}$ is generated by the start trigger.)
- <4> On detection of the valid edge of the TI_{mn} input, the value of the TCR_{mn} register is captured to timer data register mn (TDR_{mn}) and $INTTM_{mn}$ is generated. However, this capture value is nomenaing. The TCR_{mn} register keeps on counting from 0000H.
- <5> On next detection of the valid edge of the TI_{mn} input, the value of the TCR_{mn} register is captured to timer data register mn (TDR_{mn}) and $INTTM_{mn}$ is generated.

Figure 6-27. Operation Timing (In Capture Mode : Input Pulse Interval Measurement)

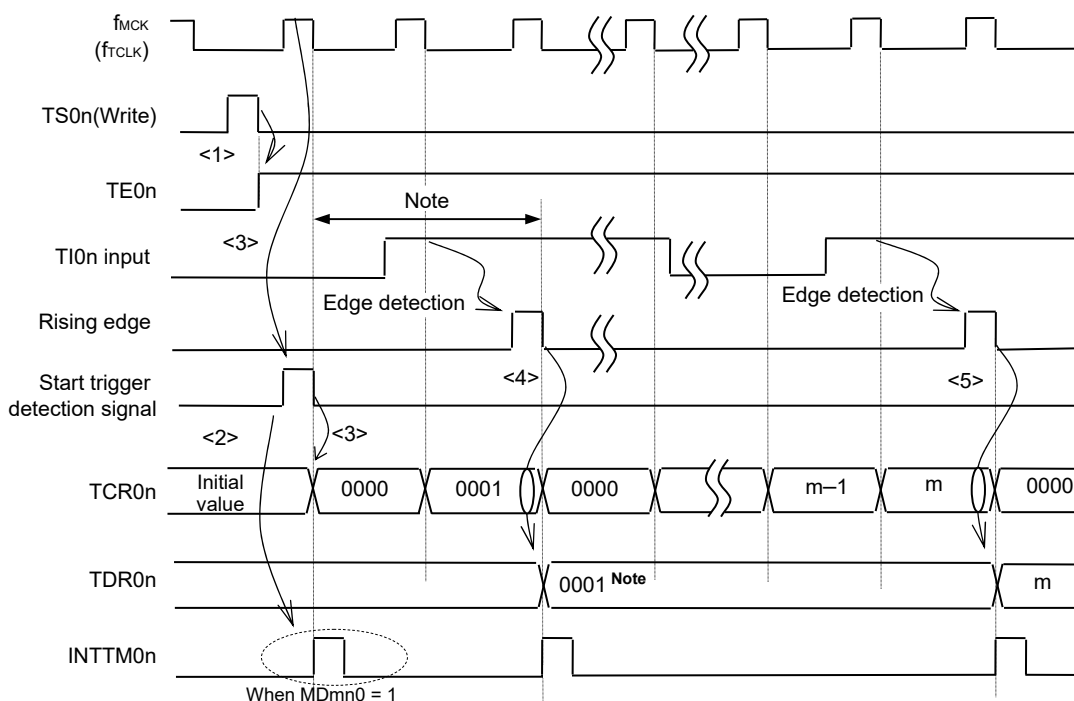

Note If a clock has been input to TI_{mn} (the trigger exists) when capturing starts, counting starts when a trigger is detected, even if no edge is detected. Therefore, the first captured value (<4>) does not determine a pulse interval (in the above figure, 0001 just indicates two clock cycles but does not determine the pulse interval) and so the user can ignore it.

Caution In the first cycle operation of count clock after writing the TS_{mn} bit, an error at a maximum of one clock is generated since count start delays until count clock has been generated. When the information on count start timing is necessary, an interrupt can be generated at count start by setting $MD_{mn0} = 1$.

Remark Figure 6-27 shows the timing when the noise filter is not used. By making the noise filter on-state, the edge detection becomes 2 f_{MCK} cycles (it sums up to 3 to 4 cycles) later than the normal cycle of TI_{mn} input. The error per one period occurs because of the asynchronous between the period of the TI_{mn} input and that of the count clock (f_{MCK}).

(4) Operation of one-count mode

- <1> Operation is enabled ($TE_{mn} = 1$) by writing 1 to the TS_{mn} bit.
- <2> Timer count register mn (TCR_{mn}) holds the initial value until start trigger generation.
- <3> Rising edge of the TI_{mn} input is detected.
- <4> On start trigger detection, the value of timer data register mn (TDR_{mn}) is loaded to the TCR_{mn} register and count starts.
- <5> When the TCR_{mn} register counts down and its count value is 0000H, $INTTM_{mn}$ is generated and the value of the TCR_{mn} register becomes FFFFH and counting stops.

Figure 6-28. Operation Timing (In One-count Mode)

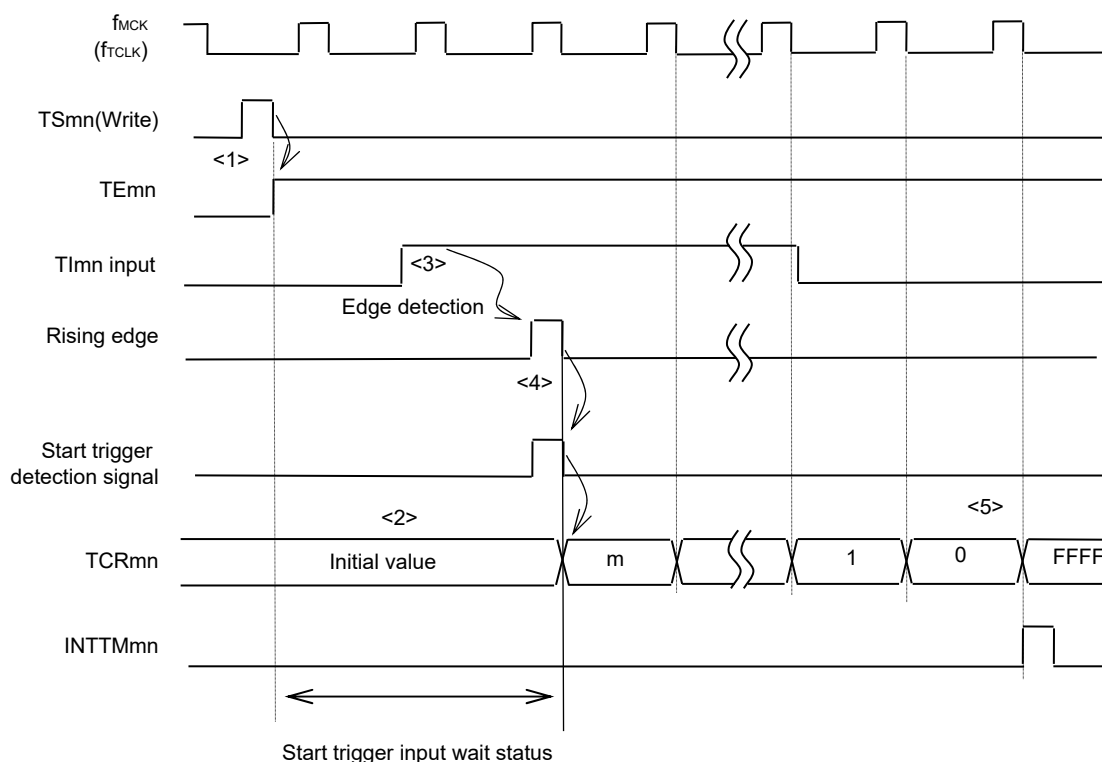

Remark Figure 6-28 shows the timing when the noise filter is not used. By making the noise filter on-state, the edge detection becomes 2 f_{MCK} cycles (it sums up to 3 to 4 cycles) later than the normal cycle of TI_{mn} input. The error per one period occurs because of the asynchronous relationship between the period of the TI_{mn} input and that of the count clock (f_{MCK}).

(5) Operation of capture & one-count mode (high-level width measurement)

- <1> Operation is enabled ($TE_{mn} = 1$) by writing 1 to the TS_{mn} bit of timer channel start register m (TS_m).
- <2> Timer count register mn (TCR_{mn}) holds the initial value until start trigger generation.
- <3> Rising edge of the TI_{mn} input is detected.
- <4> On start trigger detection, the value of 0000H is loaded to the TCR_{mn} register and count starts.
- <5> On detection of the falling edge of the TI_{mn} input, the value of the TCR_{mn} register is captured to timer data register mn (TDR_{mn}) and $INTTM_{mn}$ is generated.

Figure 6-29. Operation Timing (In Capture & One-count Mode : High-level Width Measurement)

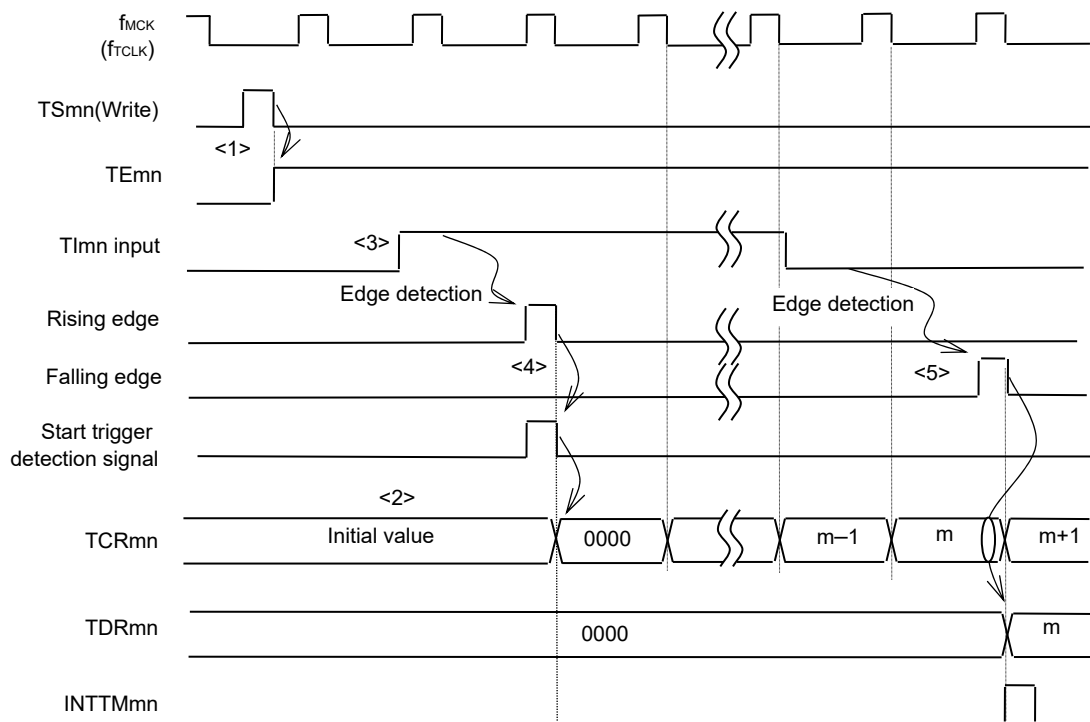

Remark Figure 6-29 shows the timing when the noise filter is not used. By making the noise filter on-state, the edge detection becomes 2 f_{MCK} cycles (it sums up to 3 to 4 cycles) later than the normal cycle of TI_{mn} input. The error per one period occurs because of the asynchronous relationship between the period of the TI_{mn} input and that of the count clock (f_{MCK}).

6.6 Channel Output (TOMn pin) Control

6.6.1 TOMn pin output circuit configuration

Figure 6-30. Output Circuit Configuration

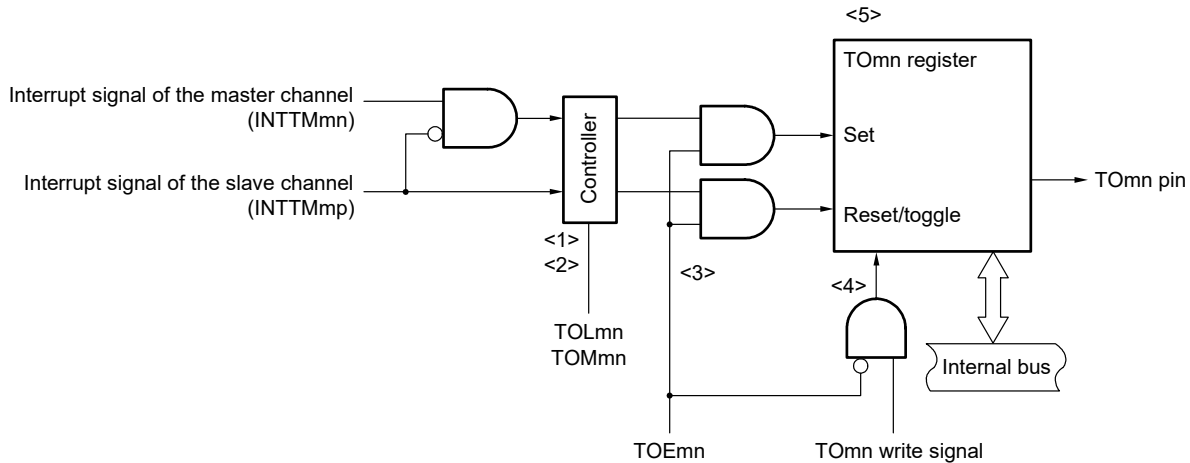

The following describes the TOMn pin output circuit.

- <1> When $TOMmn = 0$ (master channel output mode), the set value of timer output level register m ($TOLm$) is ignored and only $INTTM0p$ (slave channel timer interrupt) is transmitted to timer output register m (TOM).
- <2> When $TOMmn = 1$ (slave channel output mode), both $INTTMmn$ (master channel timer interrupt) and $INTTM0p$ (slave channel timer interrupt) are transmitted to the TOM register. At this time, the $TOLm$ register becomes valid and the signals are controlled as follows:

When $TOLmn = 0$: Positive logic output ($INTTMmn \rightarrow \text{set}$, $INTTM0p \rightarrow \text{reset}$)
 When $TOLmn = 1$: Negative logic output ($INTTMmn \rightarrow \text{reset}$, $INTTM0p \rightarrow \text{set}$)

When $INTTMmn$ and $INTTM0p$ are simultaneously generated, (0% output of PWM), $INTTM0p$ (reset signal) takes priority, and $INTTMmn$ (set signal) is masked.

- <3> While timer output is enabled ($TOEmn = 1$), $INTTMmn$ (master channel timer interrupt) and $INTTM0p$ (slave channel timer interrupt) are transmitted to the TOM register. Writing to the TOM register ($TOMn$ write signal) becomes invalid. When $TOEmn = 1$, the $TOMn$ pin output never changes with signals other than interrupt signals. To initialize the $TOMn$ pin output level, it is necessary to set timer operation is stopped ($TOEmn = 0$) and to write a value to the TOM register.
- <4> While timer output is disabled ($TOEmn = 0$), writing to the $TOMn$ bit to the target channel ($TOMn$ write signal) becomes valid. When timer output is disabled ($TOEmn = 0$), neither $INTTMmn$ (master channel timer interrupt) nor $INTTM0p$ (slave channel timer interrupt) is transmitted to the TOM register.
- <5> The TOM register can always be read, and the $TOMn$ pin output level can be checked.

Remark m : Unit number ($m = 0, 1$)
 n : Channel number
 $n = 0$ to 7 ($n = 0, 2, 4, 6$ for master channel)
 p : Slave channel number
 $n < p \leq 7$

6.6.2 TOMn Pin Output Setting

The following figure shows the procedure and status transition of the TOMn output pin from initial setting to timer operation start.

Figure 6-31. Status Transition from Timer Output Setting to Operation Start

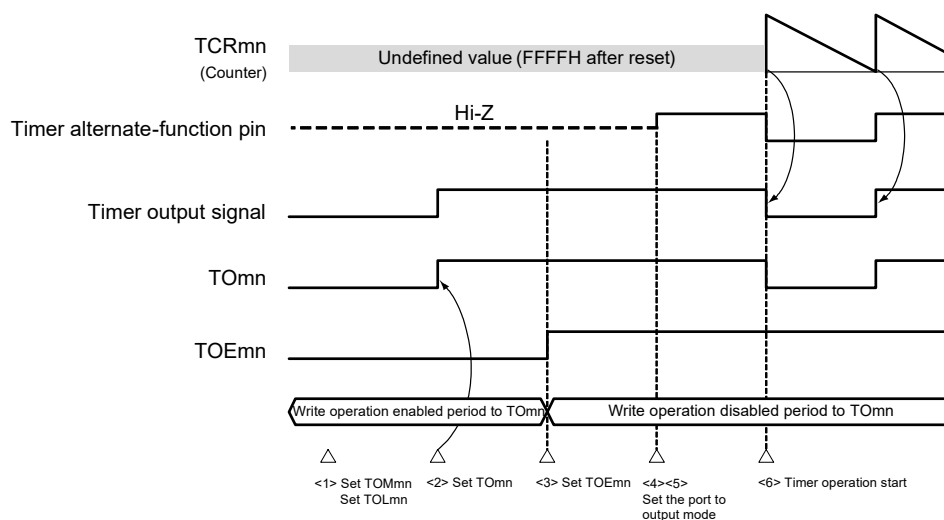

<1> The operation mode of timer output is set.

- TOMmn bit (0: Master channel output mode, 1: Slave channel output mode)
- TOLmn bit (0: Positive logic output, 1: Negative logic output)

<2> The timer output signal is set to the initial status by setting timer output register m (TOM).

<3> The timer output operation is enabled by writing 1 to the TOEmn bit (writing to the TOM register is disabled).

<4> The port is set to digital I/O by port mode control register (PMCxx) (see **6.3.15 Registers controlling port functions of pins to be used for timer I/O**).

<5> The port I/O setting is set to output (see **6.3.15 Registers controlling port functions of pins to be used for timer I/O**).

<6> The timer operation is enabled (TSMn = 1).

Remark m: Unit number (m = 0, 1), n: Channel number (n = 0 to 7)

6.6.3 Cautions on Channel Output Operation

(1) Changing values set in the registers T_{Om}, T_{OEm}, and T_{OLm} during timer operation

Since the timer operations (operations of timer count register mn (TCR mn) and timer data register mn (TDR mn)) are independent of the T_{Om} output circuit and changing the values set in timer output register m (T_{Om}), timer output enable register m (T_{OEm}), and timer output level register m (T_{OLm}) does not affect the timer operation, the values can be changed during timer operation. To output an expected waveform from the T_{Om} pin by timer operation, however, set the T_{Om}, T_{OEm}, T_{OLm}, and T_{OMm} registers to the values stated in the register setting example of each operation shown in 6.7 and 6.8.

When the values set to the T_{OEm}, and T_{OMm} registers (but not the T_{Om} register) are changed close to the occurrence of the timer interrupt (INTT Mmn) of each channel, the waveform output to the T_{Om} pin might differ, depending on whether the values are changed immediately before or immediately after the timer interrupt (INTT Mmn) occurs.

Remark m: Unit number ($m = 0, 1$), n: Channel number ($n = 0$ to 7)

(2) Default level of TOMn pin and output level after timer operation start

The change in the output level of the TOMn pin when timer output register m (TOM) is written while timer output is disabled (TOEmn = 0), the initial level is changed, and then timer output is enabled (TOEmn = 1) before port output is enabled, is shown below.

(a) When operation starts with master channel output mode (TOMmn = 0) setting

The setting of timer output level register m (TOLm) is invalid when master channel output mode (TOMmn = 0). When the timer operation starts after setting the default level, the toggle signal is generated and the output level of the TOMn pin is reversed.

Figure 6-32. TOMn Pin Output Status at Toggle Output (TOMmn = 0)

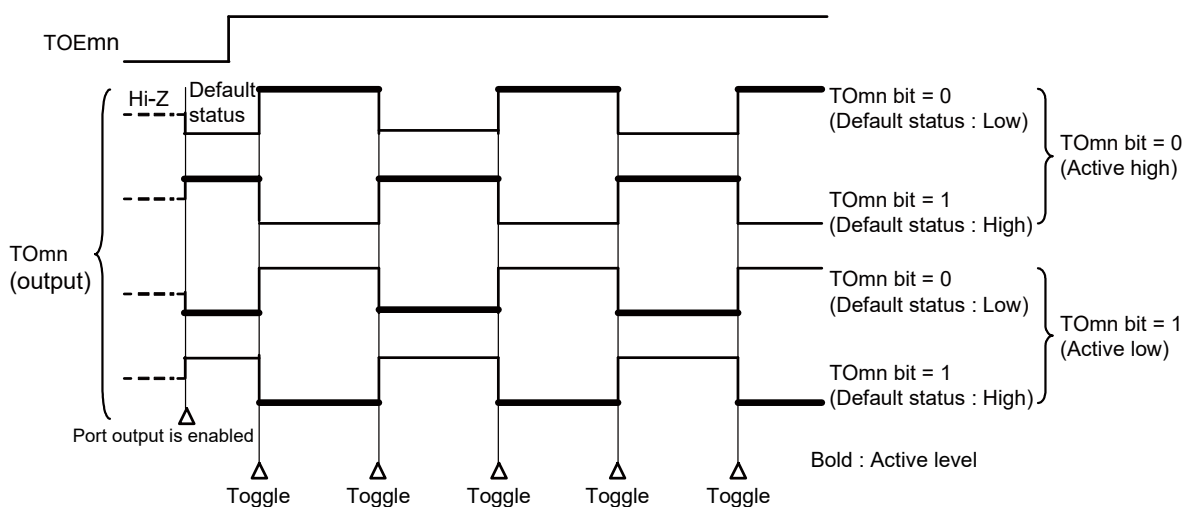

- Remarks 1.** Toggle: Reverse TOMn pin output status
- 2.** m: Unit number (m = 0, 1), n: Channel number (n = 0 to 7)

(b) When operation starts with slave channel output mode (TOMmp = 1) setting (PWM output)

When slave channel output mode (TOMmp = 1), the active level is determined by timer output level register m (TOLm) setting.

Figure 6-33. TOmp Pin Output Status at PWM Output (TOMmp = 1)

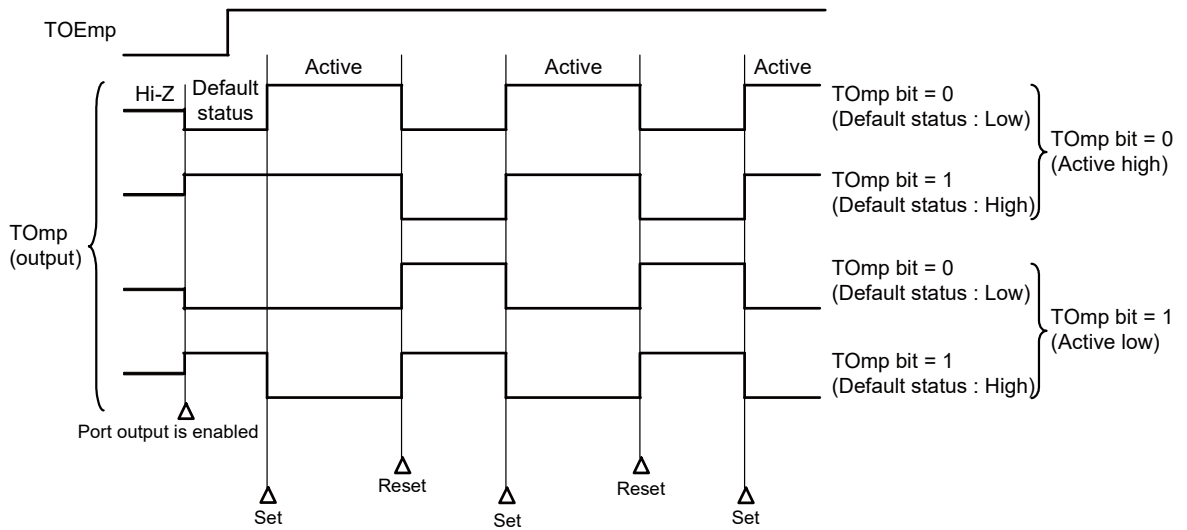

- Remarks**
1. Set: The output signal of the TOmp pin changes from inactive level to active level.
Reset: The output signal of the TOmp pin changes from active level to inactive level.
 2. m: Unit number (m = 0, 1), p: Channel number (p = 1 to 7)

(3) Operation of TOMn pin in slave channel output mode (TOMmn = 1)

(a) When timer output level register m (TOLm) setting has been changed during timer operation

When the TOLm register setting has been changed during timer operation, the setting becomes valid at the generation timing of the TOMn pin change condition. Rewriting the TOLm register does not change the output level of the TOMn pin.

The operation when TOMmn is set to 1 and the value of the TOLm register is changed while the timer is operating (TEMn = 1) is shown below.

Figure 6-34. Operation when TOLm Register Has Been Changed Contents during Timer Operation

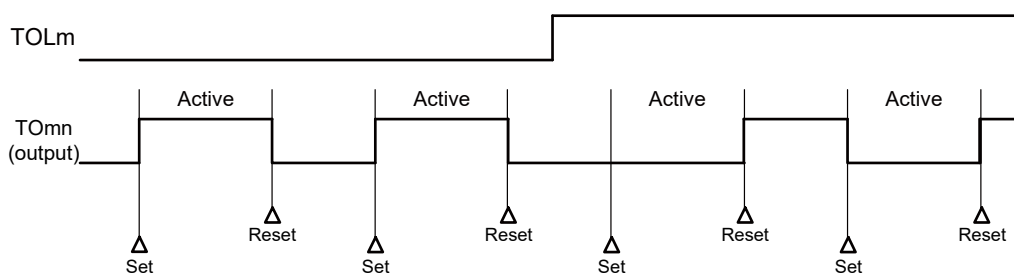

- Remarks 1.** Set: The output signal of the TOMn pin changes from inactive level to active level.
 Reset: The output signal of the TOMn pin changes from active level to inactive level.
- 2.** m: Unit number (m = 0, 1), n: Channel number (n = 0 to 7)

(b) Set/reset timing

To realize 0%/100% output at PWM output, the TOMn pin/TOMn bit set timing at master channel timer interrupt (INTTMmn) generation is delayed by 1 count clock by the slave channel.

If the set condition and reset condition are generated at the same time, a higher priority is given to the latter.

Figure 6-35 shows the set/reset operating statuses where the master/slave channels are set as follows.

- Master channel: TOEmn = 1, TOMmn = 0, TOLmn = 0
 Slave channel: TOEmp = 1, TOMmp = 1, TOLmp = 0

Figure 6-35. Set/Reset Timing Operating Statuses

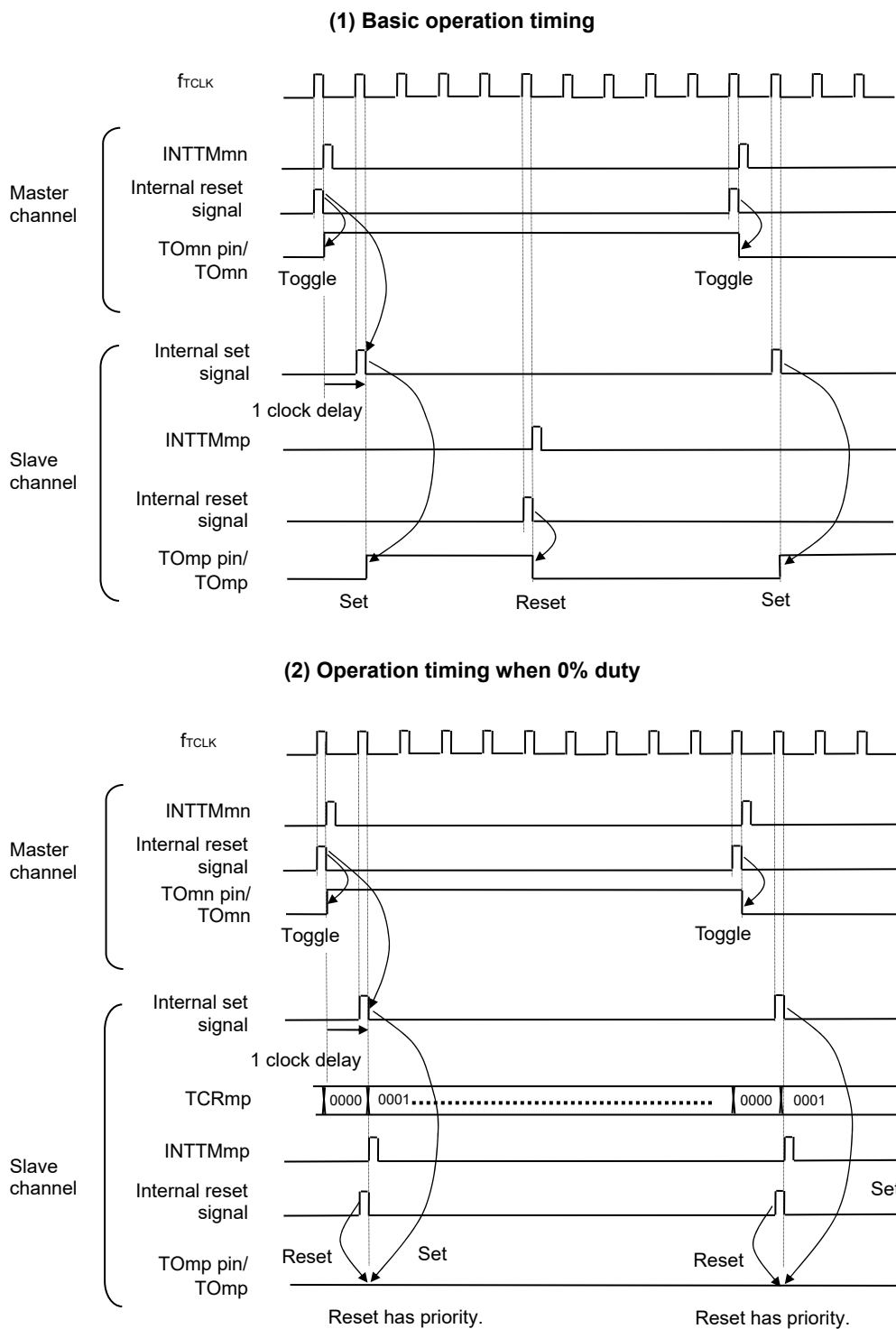

- Remarks 1.** Internal reset signal: TOmn pin reset/toggle signal
 Internal set signal: TOmn pin set signal
- 2.** m: Unit number (m = 0, 1)
 n: Channel number
 n = 0 to 7 (n = 0, 2, 4, 6 for master channel)
 p: Slave channel number
 n < p ≤ 7

6.6.4 Collective manipulation of TOMn bit

In timer output register m (TOM), the setting bits for all the channels are located in one register in the same way as timer channel start register m (TSM). Therefore, the TOMn bit of all the channels can be manipulated collectively.

Only the desired bits can also be manipulated by enabling writing only to the TOMn bits (TOEmn = 0) that correspond to the relevant bits of the channel used to perform output (TOMn).

Figure 6-36. Example of TO0n Bit Collective Manipulation

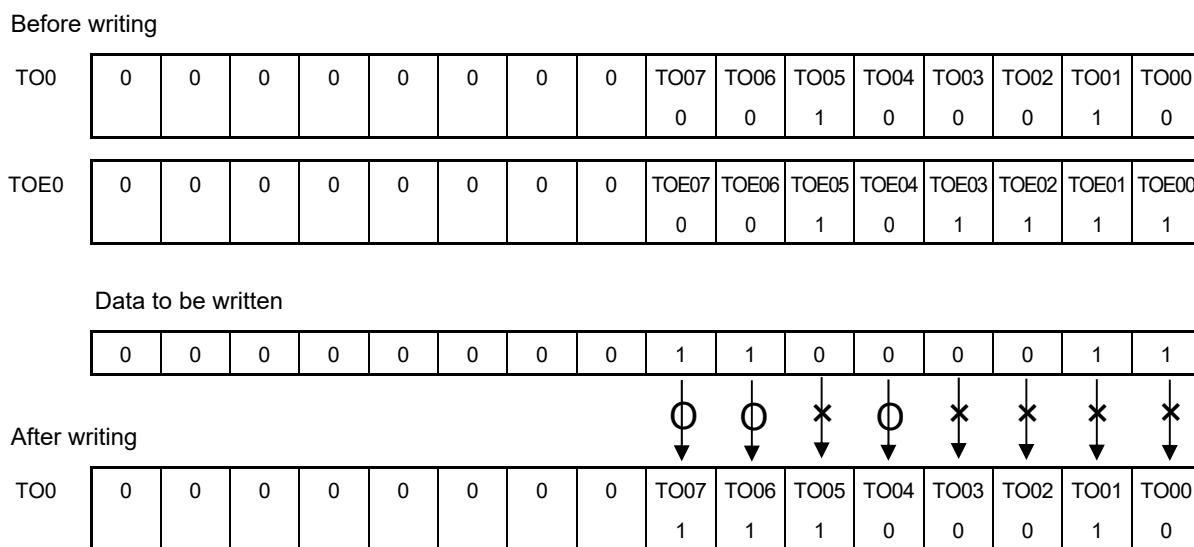

Writing is done only to the TOMn bit with TOEmn = 0, and writing to the TOMn bit with TOEmn = 1 is ignored.

TOMn (channel output) to which TOEmn = 1 is set is not affected by the write operation. Even if the write operation is done to the TOMn bit, it is ignored and the output change by timer operation is normally done.

Figure 6-37. TO0n Pin Statuses by Collective Manipulation of TO0n Bit

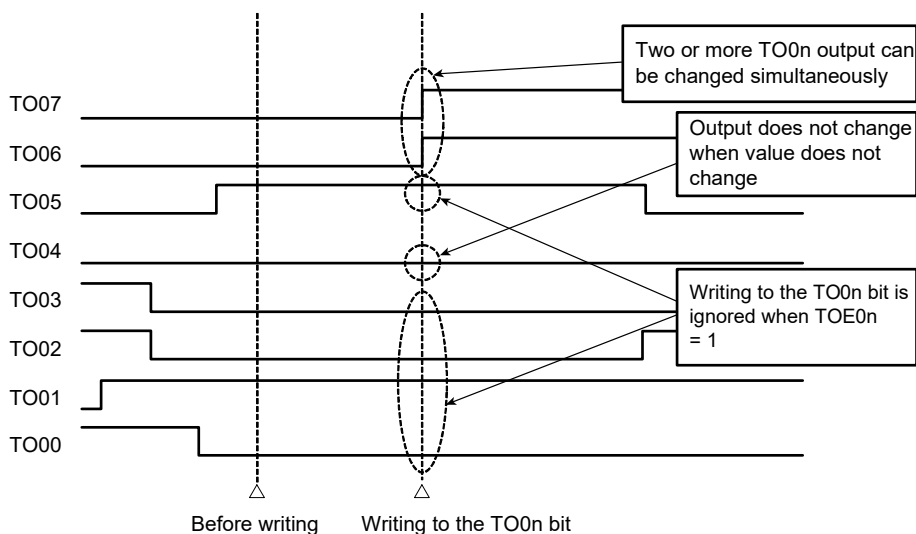

Remark m: Unit number (m = 0, 1), n: Channel number (n = 0 to 7)

6.6.5 Timer Interrupt and TOMn Pin Output at Operation Start

In the interval timer mode or capture mode, the MDmn0 bit in timer mode register mn (TMRmn) sets whether or not to generate a timer interrupt at count start.

When MDmn0 is set to 1, the count operation start timing can be known by the timer interrupt (INTTMmn) generation. In the other modes, neither timer interrupt at count operation start nor TOMn output is controlled.

Figure 6-38 shows operation examples when the interval timer mode (TOEmn = 1, TOMmn = 0) is set.

Figure 6-38. Operation examples of timer interrupt at count operation start and TOMn output

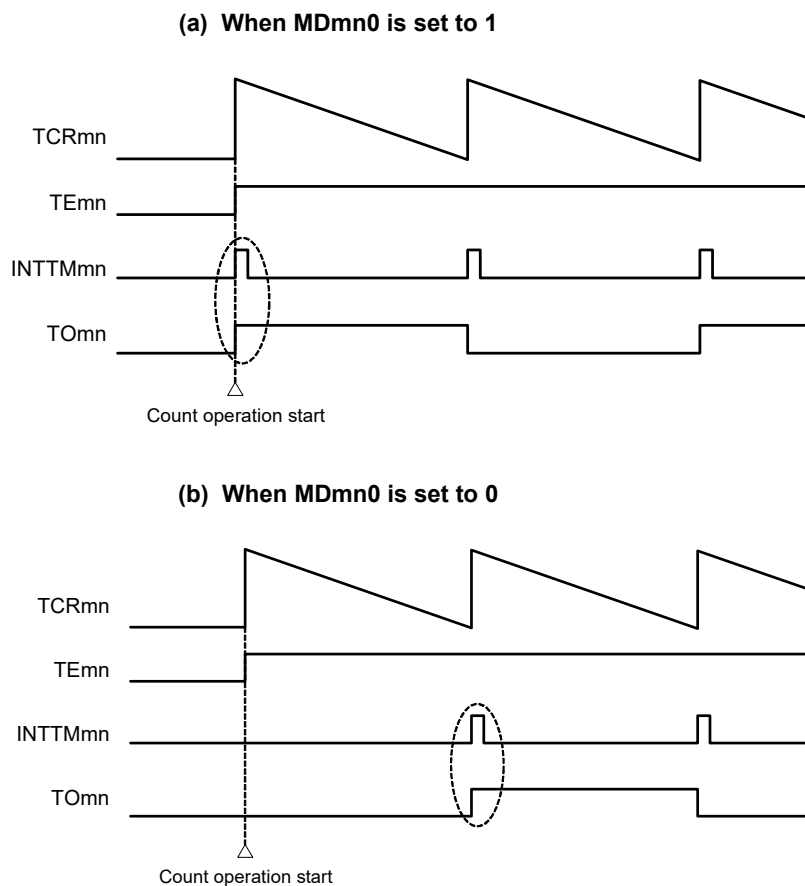

When MDmn0 is set to 1, a timer interrupt (INTTMmn) is output at count operation start, and TOMn performs a toggle operation.

When MDmn0 is set to 0, a timer interrupt (INTTMmn) is not output at count operation start, and TOMn does not change either. After counting one cycle, INTTMmn is output and TOMn performs a toggle operation.

Remark m: Unit number (m = 0, 1), n: Channel number (n = 0 to 7)

6.7 Timer Input (TImn) Control

6.7.1 TImn input circuit configuration

A signal is input from a timer input pin, goes through a noise filter and an edge detector, and is sent to a timer controller. Enable the noise filter for the pin in need of noise removal. The following shows the configuration of the input circuit.

Figure 6-39. Input Circuit Configuration

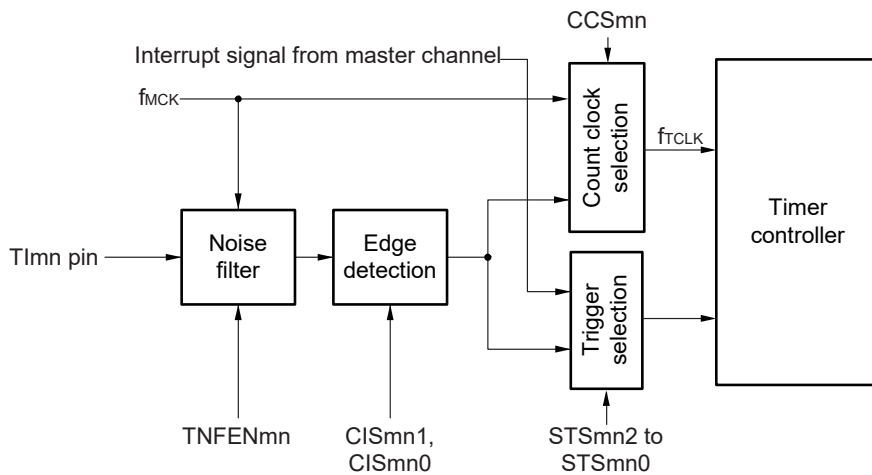

6.7.2 Noise filter

When the noise filter is disabled, the input signal is only synchronized with the operating clock (f_{MCK}) for channel n . When the noise filter is enabled, after synchronization with the operating clock (f_{MCK}) for channel n , whether the signal keeps the same value for two clock cycles is detected. The following shows differences in waveforms output from the noise filter between when the noise filter is enabled and disabled.

Figure 6-40. Sampling Waveforms through TImn Input Pin with Noise Filter Enabled and Disabled

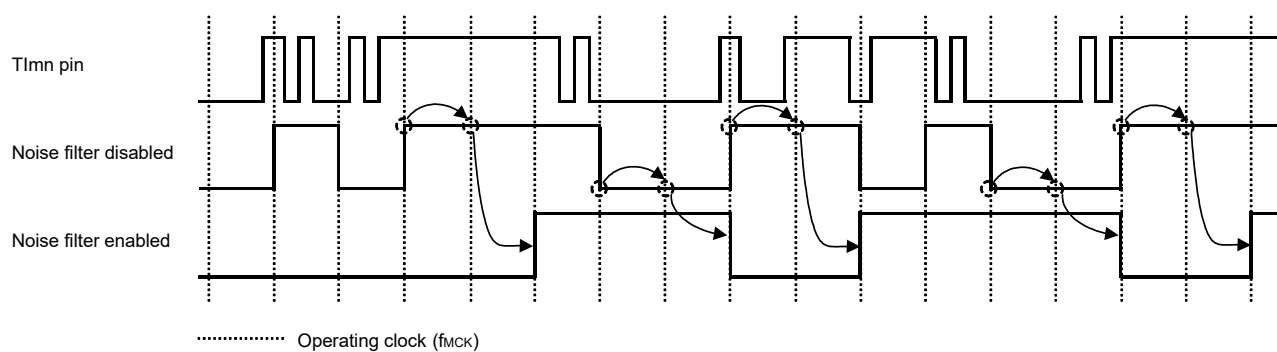

6.7.3 Cautions on channel input operation

When a timer input pin is set as unused, the operating clock is not supplied to the noise filter. Therefore, after settings are made to use the timer input pin, the following wait time is necessary before a trigger is specified to enable operation of the channel corresponding to the timer input pin.

(1) Noise filter is disabled

When bits 12 (CCSmn), 9 (STSmn1), and 8 (STSmn0) in the timer mode register mn (TMRmn) are 0 and then one of them is set to 1, wait for at least two cycles of the operating clock (f_{MCK}), and then set the operation enable trigger bit in the timer channel start register (TSM).

(2) Noise filter is enabled

When bits 12 (CCSmn), 9 (STSmn1), and 8 (STSmn0) in the timer mode register mn (TMRmn) are all 0 and then one of them is set to 1, wait for at least four cycles of the operating clock (f_{MCK}), and then set the operation enable trigger bit in the timer channel start register (TSM).

6.8 Independent Channel Operation Function of Timer Array Unit

6.8.1 Operation as interval timer/square wave output

(1) Interval timer

The timer array unit can be used as a reference timer that generates INTTM_{mn} (timer interrupt) at fixed intervals. The interrupt generation period can be calculated by the following expression.

$$\text{Generation period of INTTM}_{mn} \text{ (timer interrupt)} = \text{Period of count clock} \times (\text{Set value of TDR}_{mn} + 1)$$

(2) Operation as square wave output

TOM_n performs a toggle operation as soon as INTTM_{mn} has been generated, and outputs a square wave with a duty factor of 50%.

The period and frequency for outputting a square wave from TOM_n can be calculated by the following expressions.

$$\bullet \text{ Period of square wave output from TOM}_n = \text{Period of count clock} \times (\text{Set value of TDR}_{mn} + 1) \times 2$$

$$\bullet \text{ Frequency of square wave output from TOM}_n = \text{Frequency of count clock} / \{(\text{Set value of TDR}_{mn} + 1) \times 2\}$$

Timer count register mn (TCR_{mn}) operates as a down counter in the interval timer mode.

The TCR_{mn} register loads the value of timer data register mn (TDR_{mn}) at the first count clock after the channel start trigger bit (TSM_n, TSH_{m1}, TSH_{m3}) of timer channel start register m (TSM) is set to 1. If the MD_{mn0} bit of timer mode register mn (TMR_{mn}) is 0 at this time, INTTM_{mn} is not output and TOM_n is not toggled. If the MD_{mn0} bit of the TMR_{mn} register is 1, INTTM_{mn} is output and TOM_n is toggled.

After that, the TCR_{mn} register count down in synchronization with the count clock.

When TCR_{mn} = 0000H, INTTM_{mn} is output and TOM_n is toggled at the next count clock. At the same time, the TCR_{mn} register loads the value of the TDR_{mn} register again. After that, the same operation is repeated.

The TDR_{mn} register can be rewritten at any time. The new value of the TDR_{mn} register becomes valid from the next period.

Remark m: Unit number (m = 0, 1), n: Channel number (n = 0 to 7)

Figure 6-41. Block Diagram of Operation as Interval Timer/Square Wave Output

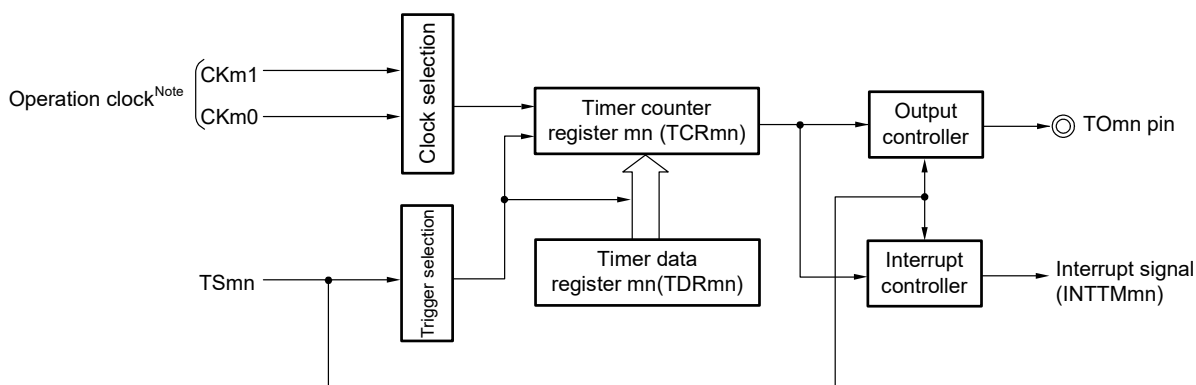

Note When channels 1 and 3, the clock can be selected from CKm0, CKm1, CKm2 and CKm3.

Figure 6-42. Example of Basic Timing of Operation as Interval Timer/Square Wave Output (MDmn0 = 1)

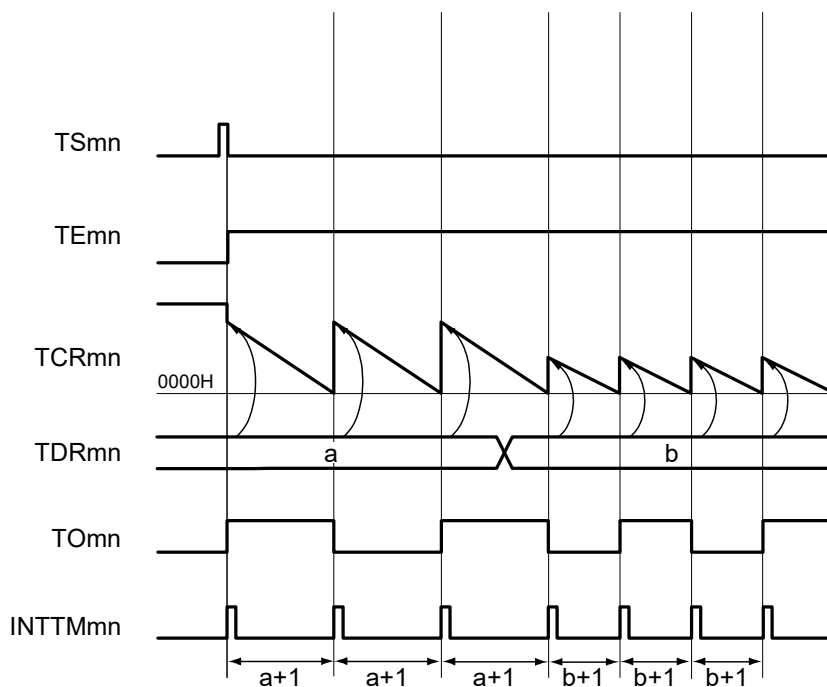

- Remarks**
1. m: Unit number (m = 0, 1), n: Channel number (n = 0 to 7)
 2. TSmn: Bit n of timer channel start register m (TSm)
 - TEMn: Bit n of timer channel enable status register m (TEm)
 - TCRmn: Timer count register mn (TCRmn)
 - TDRmn: Timer data register mn (TDRmn)
 - TOMn: TOMn pin output signal

Figure 6-43. Example of Set Contents of Registers During Operation as Interval Timer/Square Wave Output (1/2)

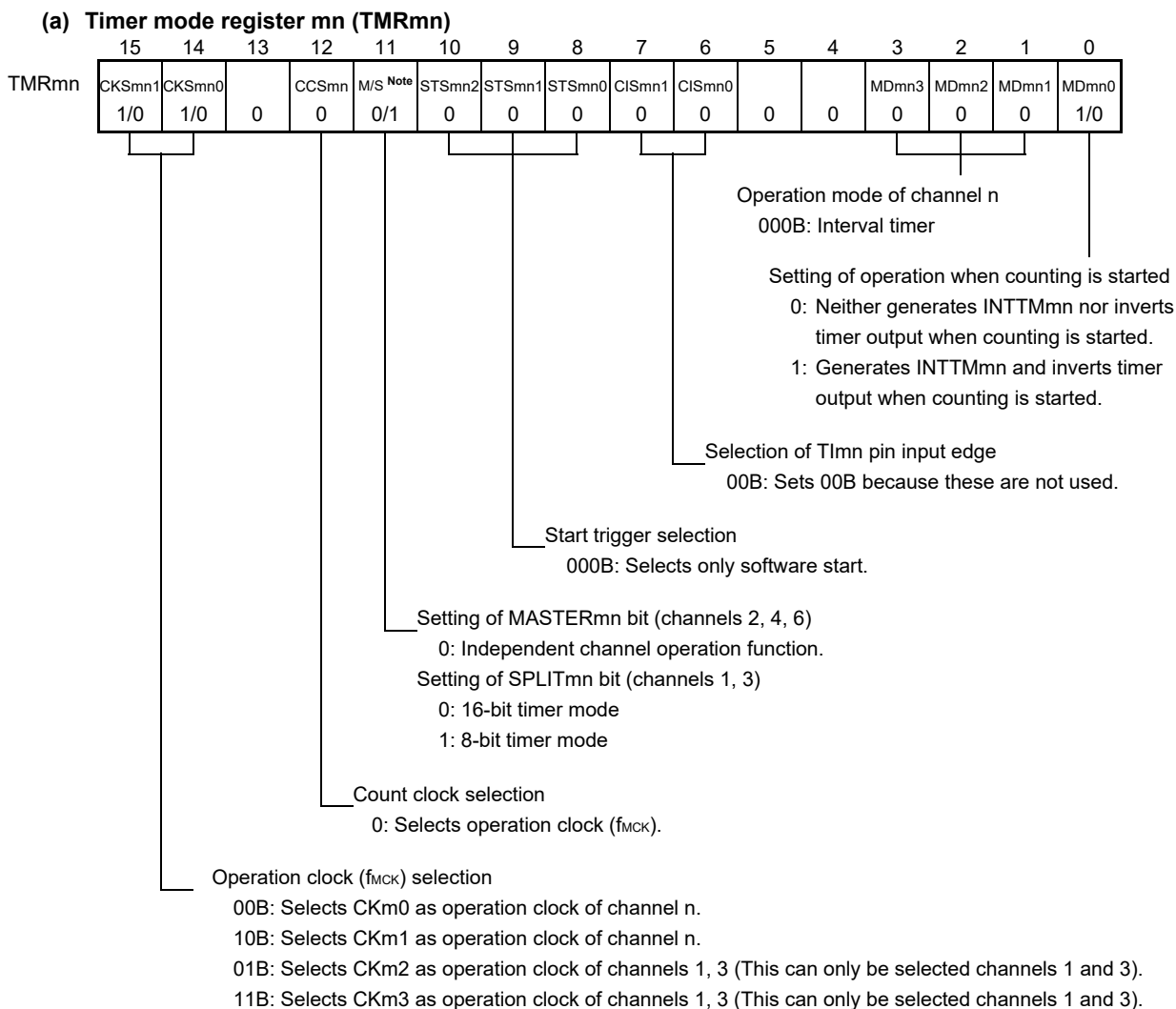

(b) **Timer output register m (TOM)**

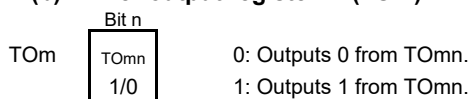

(c) **Timer output enable register m (TOEm)**

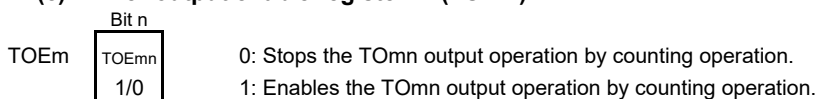

Note TMRm2, TMRm4, TMRm6: MASTERmn bit
 TMRm1, TMRm3: SPLITmn bit
 TMRm0, TMRm5, TMRm7: Fixed to 0

Remark m: Unit number (m = 0, 1), n: Channel number (n = 0 to 7)

Figure 6-43. Example of Set Contents of Registers During Operation as Interval Timer/Square Wave Output (2/2)**(d) Timer output level register m (TOLm)**

TOLm

Bit n
TOLmn
0

 0: Cleared to 0 when TOMmn = 0 (master channel output mode)

(e) Timer output mode register m (TOMm)

TOMm

Bit n
TOMmn
0

 0: Sets master channel output mode.

Remark m: Unit number (m = 0, 1), n: Channel number (n = 0 to 7)

Figure 6-44. Operation Procedure of Interval Timer/Square Wave Output Function (1/2)

	Software Operation	Hardware Status
TAU default setting		Power-off status (Clock supply is stopped and writing to each register is disabled.)
	Sets the TAUmEN bit of peripheral enable register 0 (PER0) to 1.	Power-on status. Each channel stops operating. (Clock supply is started and writing to each register is enabled.)
	Sets timer clock select register m (TPSm). Determines clock frequencies of CKm0 to CKm3.	
Channel default setting	Sets timer mode register mn (TMRmn) (determines operation mode of channel). Sets interval (period) value to timer data register mn (TDRmn).	Channel stops operating. (Clock is supplied and some power is consumed.)
	To use the TOMn output Clears the TOMmn bit of timer output mode register m (TOMm) to 0 (master channel output mode). Clears the TOLmn bit to 0. Sets the TOMn bit and determines default level of the TOMn output.	The TOMn pin goes into Hi-Z output state. The TOMn default setting level is output when the port mode register is in the output mode and the port register is 0.
	Sets the TOEmn bit to 1 and enables operation of TOMn. Clears the port register and port mode register to 0.	TOMn does not change because channel stops operating. The TOMn pin outputs the TOMn set level.
Operation start	(Sets the TOEmn bit to 1 only if using TOMn output and resuming operation.) Sets the TSmn (TSHm1, TSHm3) bit to 1. The TSmn (TSHm1, TSHm3) bit automatically returns to 0 because it is a trigger bit.	TEmn (TEHm1, TEHm3) = 1, and count operation starts. Value of the TDRmn register is loaded to timer count register mn (TCRmn). INTTMmn is generated and TOMn performs toggle operation if the MDmn0 bit of the TMRmn register is 1.
During operation	Set values of the TMRmn register, TOMmn, and TOLmn bits cannot be changed. Set value of the TDRmn register can be changed. The TCRmn register can always be read. The TSRmn register is not used. Set values of the TOM and TOEm registers can be changed.	Counter (TCRmn) counts down. When count value reaches 0000H, the value of the TDRmn register is loaded to the TCRmn register again and the count operation is continued. By detecting TCRmn = 0000H, INTTMmn is generated and TOMn performs toggle operation. After that, the above operation is repeated.
Operation stop	The TTmn (TTHm1, TTHm3) bit is set to 1. The TTmn (TTHm1, TTHm3) bit automatically returns to 0 because it is a trigger bit.	TEmn (TEHm1, TEHm3), and count operation stops. The TCRmn register holds count value and stops. The TOMn output is not initialized but holds current status.
	The TOEmn bit is cleared to 0 and value is set to the TOMn bit.	The TOMn pin outputs the TOMn bit set level.

Operation is resumed.

(Remark is listed on the next page.)

Figure 6-44. Operation Procedure of Interval Timer/Square Wave Output Function (2/2)

	Software Operation	Hardware Status
TAU stop	To hold the TOMn pin output level Clears the TOMn bit to 0 after the value to be held is set to the port register. —————> When holding the TOMn pin output level is not necessary Setting not required. ----- The TAUmEN bit of the PER0 register is cleared to 0. —>	The TOMn pin output level is held by port function. ----- Power-off status All circuits are initialized and SFR of each channel is also initialized. (The TOMn bit is cleared to 0 and the TOMn pin is set to port mode.)

Remark m: Unit number (m = 0, 1), n: Channel number (n = 0 to 7)

6.8.2 Operation as external event counter

The timer array unit can be used as an external event counter that counts the number of times the valid input edge (external event) is detected in the TImn pin. When a specified count value is reached, the event counter generates an interrupt. The specified number of counts can be calculated by the following expression.

$$\text{Specified number of counts} = \text{Set value of TDRmn} + 1$$

Timer count register mn (TCRmn) operates as a down counter in the event counter mode.

The TCRmn register loads the value of timer data register mn (TDRmn) by setting any channel start trigger bit (TSmn) of timer channel start register m (TSm) to 1.

The TCRmn register counts down each time the valid input edge of the TImn pin has been detected. When TCRmn = 0000H, the TCRmn register loads the value of the TDRmn register again, and outputs INTTMmn.

After that, the above operation is repeated.

An irregular waveform that depends on external events is output from the TOmn pin. Stop the output by setting the TOEmn bit of timer output enable register m (TOEm) to 0.

The TDRmn register can be rewritten at any time. The new value of the TDRmn register becomes valid during the next count period.

Figure 6-45. Block Diagram of Operation as External Event Counter

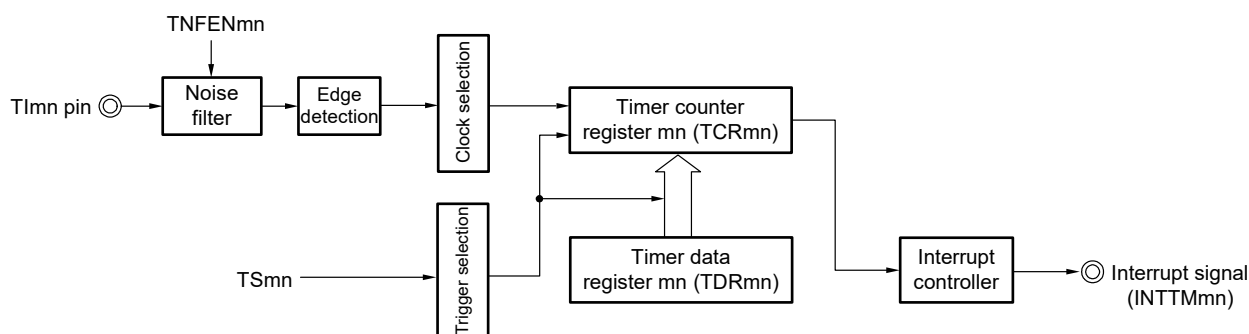

Remark m: Unit number (m = 0, 1), n: Channel number (n = 0 to 7)

Figure 6-46. Example of Basic Timing of Operation as External Event Counter

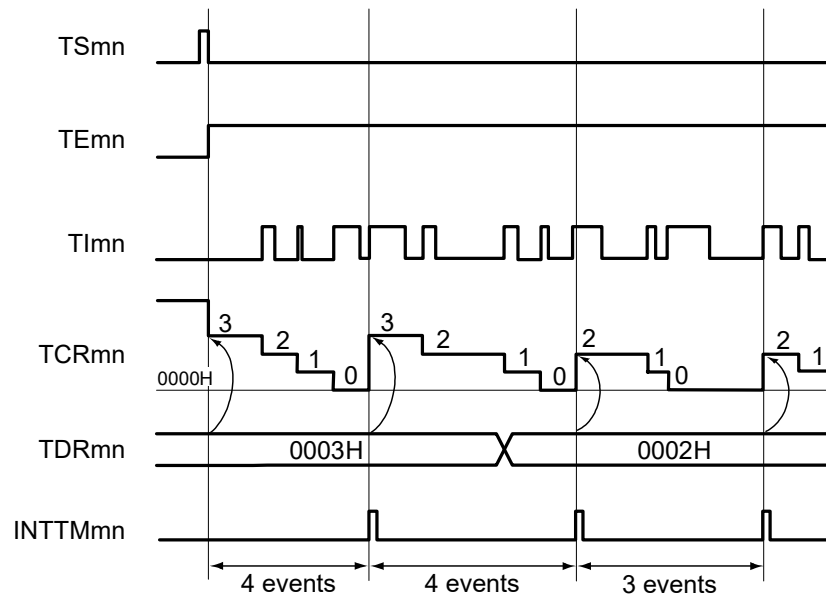

- Remarks**
1. m: Unit number (m = 0, 1), n: Channel number (n = 0 to 7)
 2. TSmn: Bit n of timer channel start register m (TSm)
 TE mn: Bit n of timer channel enable status register m (TEm)
 TImn: TImn pin input signal
 TCRmn: Timer count register mn (TCRmn)
 TDRmn: Timer data register mn (TDRmn)

Figure 6-47. Example of Set Contents of Registers in External Event Counter Mode (1/2)

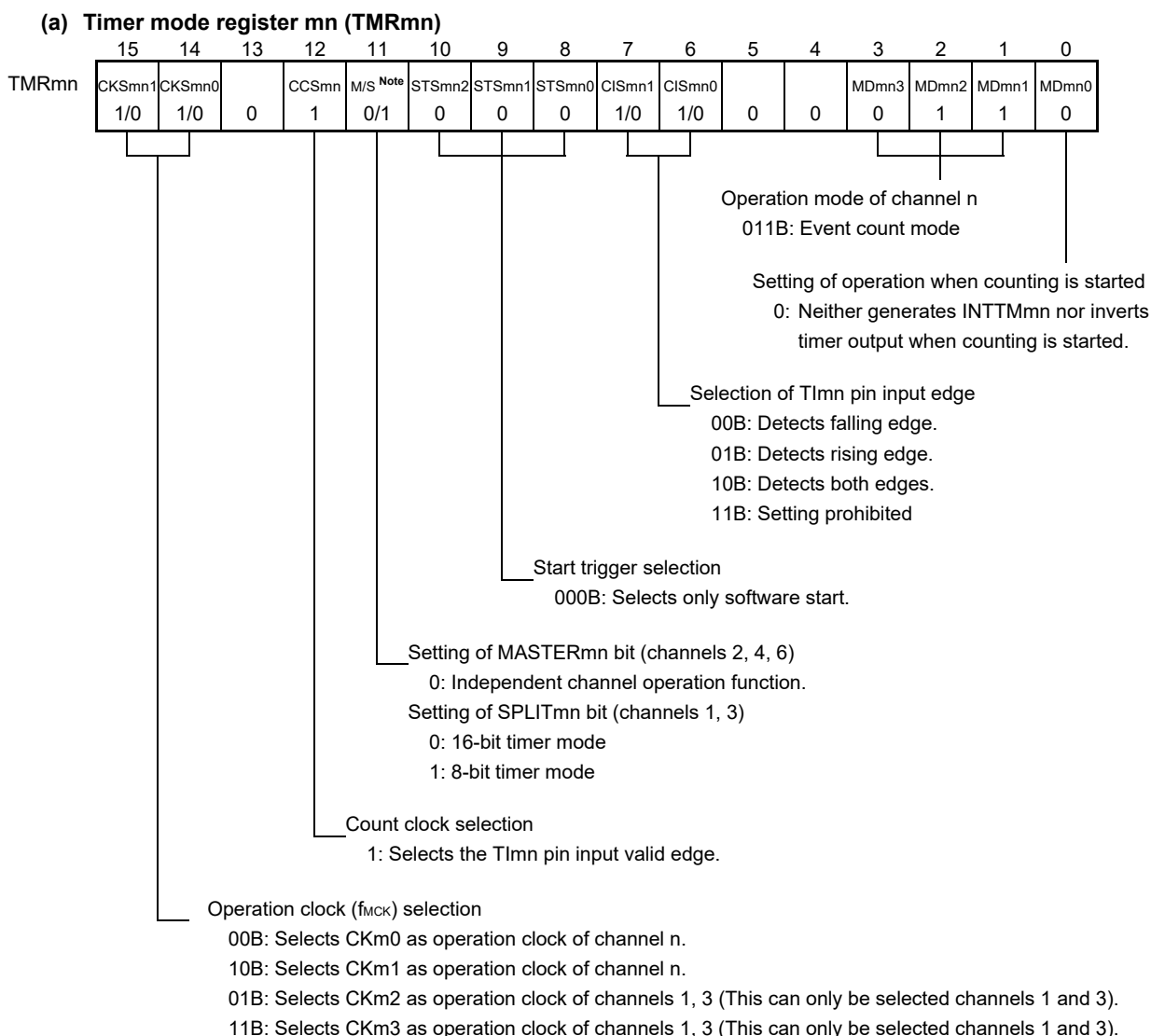

(b) Timer output register m (TOM)

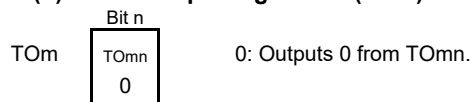

(c) Timer output enable register m (TOEm)

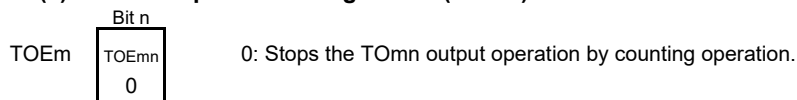

Note TMRm2, TMRm4, TMRm6: MASTERmn bit
 TMRm1, TMRm3: SPLITmn bit
 TMRm0, TMRm5, TMRm7: Fixed to 0

Remark m: Unit number (m = 0, 1), n: Channel number (n = 0 to 7)

Figure 6-47. Example of Set Contents of Registers in External Event Counter Mode (2/2)**(d) Timer output level register m (TOLm)**

TOLm

Bit n
TOLmn
0

 0: Cleared to 0 when TOMmn = 0 (master channel output mode).

(e) Timer output mode register m (TOMm)

TOMm

Bit n
TOMmn
0

 0: Sets master channel output mode.

Remark m: Unit number (m = 0, 1), n: Channel number (n = 0 to 7)

Figure 6-48. Operation Procedure When External Event Counter Function Is Used

	Software Operation	Hardware Status
TAU default setting		Power-off status (Clock supply is stopped and writing to each register is disabled.)
	Sets the TAUmEN bit of peripheral enable register 0 (PER0) to 1.	Power-on status. Each channel stops operating. (Clock supply is started and writing to each register is enabled.)
	Sets timer clock select register m (TPSm). Determines clock frequencies of CKm0 to CKm3.	
Channel default setting	Sets the corresponding bit of the noise filter enable registers 1, 2 (NFEN1, NFEN2) to 0 (off) or 1 (on). Sets timer mode register mn (TMRmn) (determines operation mode of channel). Sets number of counts to timer data register mn (TDRmn). Clears the TOEmn bit of timer output enable register m (TOEm) to 0.	Channel stops operating. (Clock is supplied and some power is consumed.)
Operation start	Sets the TSmn bit to 1. The TSmn bit automatically returns to 0 because it is a trigger bit.	TEmn = 1, and count operation starts. Value of the TDRmn register is loaded to timer count register mn (TCRmn) and detection of the TImn pin input edge is awaited.
During operation	Set value of the TDRmn register can be changed. The TCRmn register can always be read. The TSRmn register is not used. Set values of the TMRmn register, TOMmn, TOLmn, TOmn, and TOEmn bits cannot be changed.	Counter (TCRmn) counts down each time input edge of the TImn pin has been detected. When count value reaches 0000H, the value of the TDRmn register is loaded to the TCRmn register again, and the count operation is continued. By detecting TCRmn = 0000H, the INTTMmn output is generated. After that, the above operation is repeated.
Operation stop	The TTmn bit is set to 1. The TTmn bit automatically returns to 0 because it is a trigger bit.	TEmn = 0, and count operation stops. The TCRmn register holds count value and stops.
TAU stop	The TAUmEN bit of the PER0 register is cleared to 0.	Power-off status All circuits are initialized and SFR of each channel is also initialized.

Operation is resumed.

Remark m: Unit number (m = 0, 1), n: Channel number (n = 0 to 7)

6.8.3 Operation as frequency divider (channel 0 of unit 0 only)

The timer array unit can be used as a frequency divider that divides a clock input to the TI00 pin and outputs the result from the TO00 pin.

The divided clock frequency output from TO00 can be calculated by the following expression.

- When rising edge/falling edge is selected:

$$\text{Divided clock frequency} = \text{Input clock frequency} / \{(\text{Set value of TDR00} + 1) \times 2\}$$
- When both edges are selected:

$$\text{Divided clock frequency} \approx \text{Input clock frequency} / (\text{Set value of TDR00} + 1)$$

Timer count register 00 (TCR00) operates as a down counter in the interval timer mode.

After the channel start trigger bit (TS00) of timer channel start register 0 (TS0) is set to 1, the TCR00 register loads the value of timer data register 00 (TDR00) when the TI00 valid edge is detected.

If the MD000 bit of timer mode register 00 (TMR00) is 0 at this time, INTTM00 is not output and TO00 is not toggled. If the MD000 bit of timer mode register 00 (TMR00) is 1, INTTM00 is output and TO00 is toggled.

After that, the TCR00 register counts down at the valid edge of the TI00 pin. When TCR00 = 0000H, it toggles TO00. At the same time, the TCR00 register loads the value of the TDR00 register again, and continues counting.

If detection of both the edges of the TI00 pin is selected, the duty factor error of the input clock affects the divided clock period of the TO00 output.

The period of the TO00 output clock includes a sampling error of one period of the operation clock.

$$\text{Clock period of TO00 output} = \text{Ideal TO00 output clock period} \pm \text{Operation clock period (error)}$$

The TDR00 register can be rewritten at any time. The new value of the TDR00 register becomes valid during the next count period.

Figure 6-49. Block Diagram of Operation as Frequency Divider

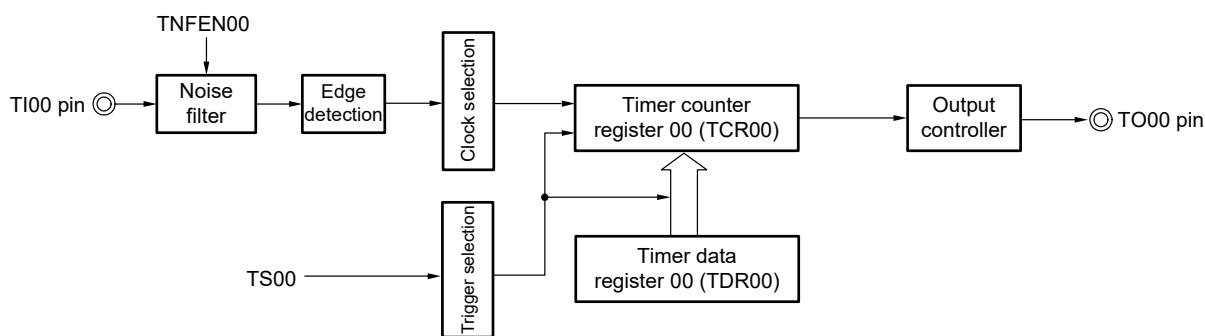
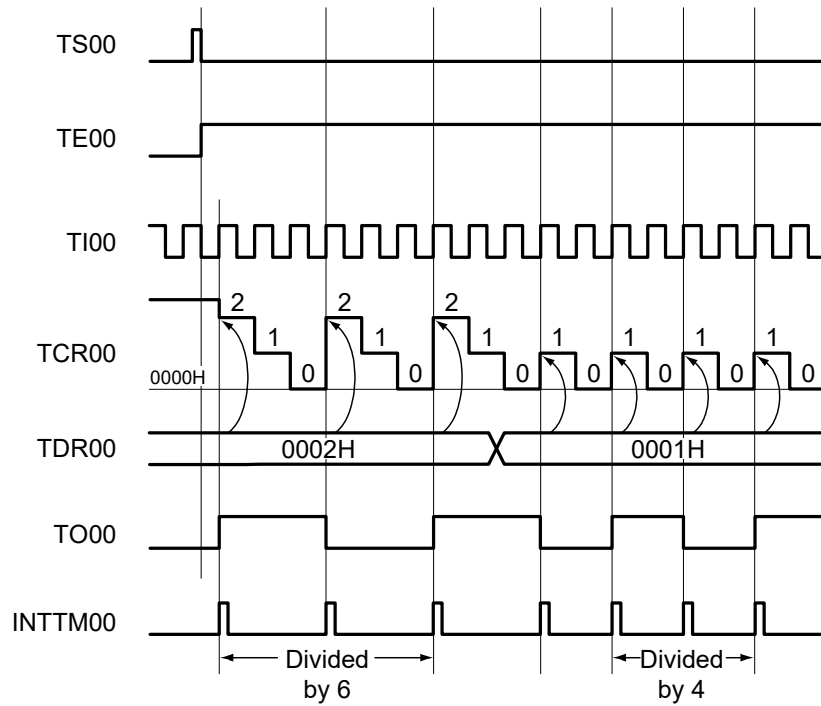
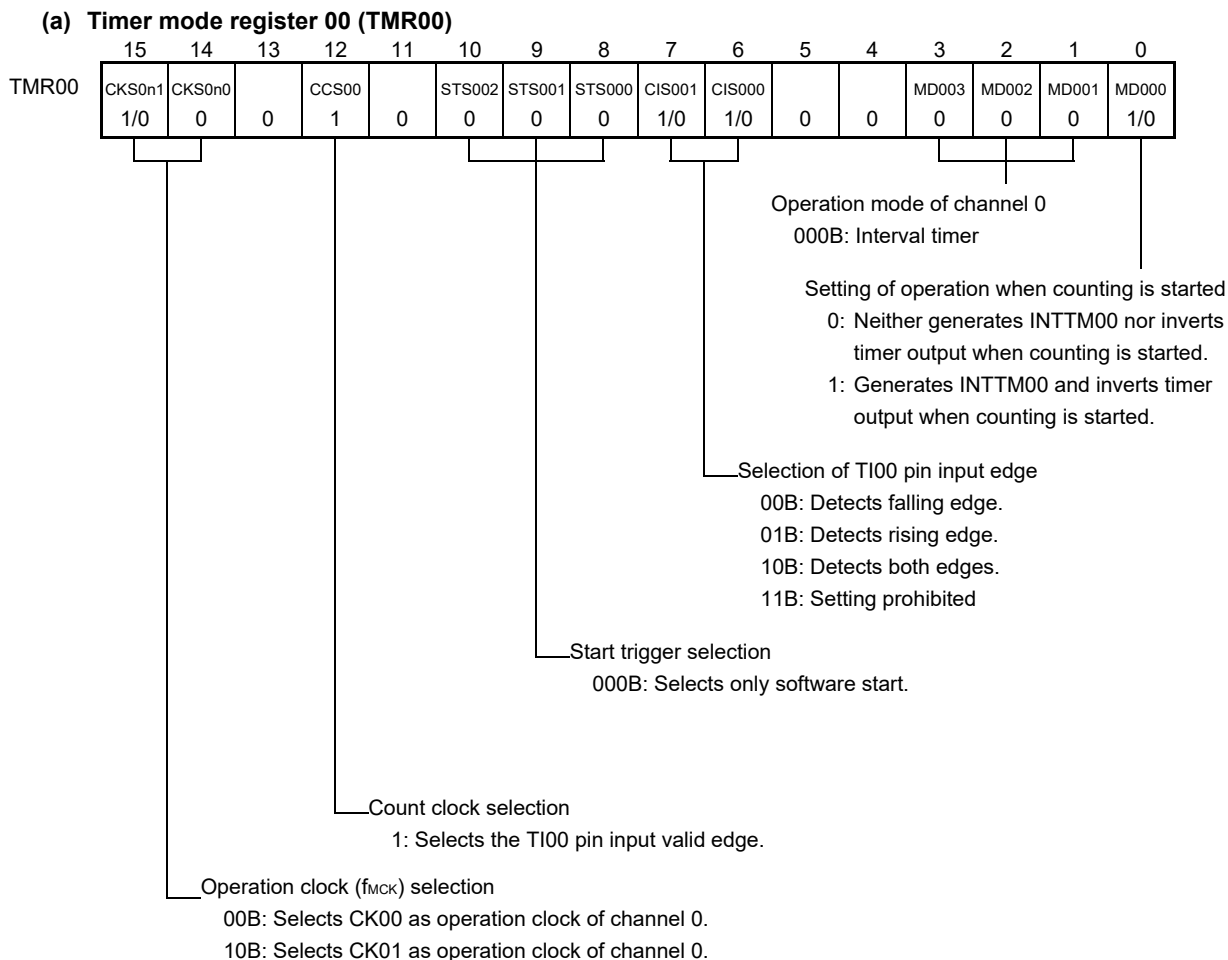

Figure 6-50. Example of Basic Timing of Operation as Frequency Divider (MD000 = 1)



- Remark**
- TS00: Bit n of timer channel start register 0 (TS0)
 - TE00: Bit n of timer channel enable status register 0 (TE0)
 - TI00: TI00 pin input signal
 - TCR00: Timer count register 00 (TCR00)
 - TDR00: Timer data register 00 (TDR00)
 - TO00: TO00 pin output signal

Figure 6-51. Example of Set Contents of Registers During Operation as Frequency Divider



(b) **Timer output register 0 (TO0)**

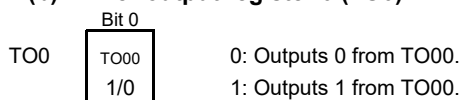

(c) **Timer output enable register 0 (TOE0)**

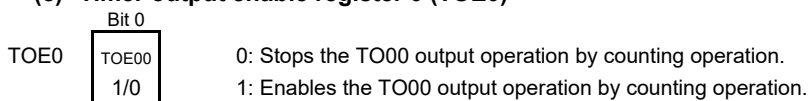

(d) **Timer output level register 0 (TOL0)**

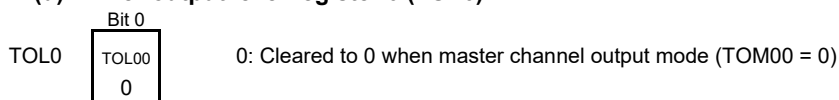

(e) **Timer output mode register 0 (TOM0)**

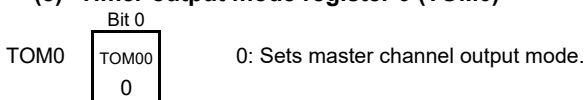

Figure 6-52. Operation Procedure When Frequency Divider Function Is Used

	Software Operation	Hardware Status
TAU default setting		Power-off status (Clock supply is stopped and writing to each register is disabled.)
	Sets the TAU0EN bit of peripheral enable register 0 (PER0) to 1.	Power-on status. Each channel stops operating. (Clock supply is started and writing to each register is enabled.)
	Sets timer clock select register 0 (TPS0). Determines clock frequencies of CK00 to CK03.	
Channel default setting	Sets the corresponding bit of the noise filter enable registers 1, 2 (NFEN1, NFEN2) to 0 (off) or 1 (on). Sets timer mode register 0n (TMR0n) (determines operation mode of channel and selects the detection edge). Sets interval (period) value to timer data register 00 (TDR00).	Channel stops operating. (Clock is supplied and some power is consumed.)
	Clears the TOM00 bit of timer output mode register 0 (TOM0) to 0 (master channel output mode). Clears the TOL00 bit to 0. Sets the TO00 bit and determines default level of the TO00 output.	The TO00 pin goes into Hi-Z output state. The TO00 default setting level is output when the port mode register is in output mode and the port register is 0.
	Sets the TOE00 bit to 1 and enables operation of TO00. Clears the port register and port mode register to 0.	TO00 does not change because channel stops operating. The TO00 pin outputs the TO00 set level.
Operation start	Sets the TOE00 bit to 1 (only when operation is resumed). Sets the TS00 bit to 1. The TS00 bit automatically returns to 0 because it is a trigger bit.	TE00 = 1, and count operation starts. Value of the TDR00 register is loaded to timer count register 00 (TCR00). INTTM00 is generated and TO00 performs toggle operation if the MD000 bit of the TMR00 register is 1.
During operation	Set value of the TDR00 register can be changed. The TCR00 register can always be read. The TSR00 register is not used. Set values of the TO0 and TOE0 registers can be changed. Set values of the TMR00 register, TOM00, and TOL00 bits cannot be changed.	Counter (TCR00) counts down. When count value reaches 0000H, the value of the TDR00 register is loaded to the TCR00 register again, and the count operation is continued. By detecting TCR00 = 0000H, INTTM00 is generated and TO00 performs toggle operation. After that, the above operation is repeated.
Operation stop	The TT00 bit is set to 1. The TT00 bit automatically returns to 0 because it is a trigger bit.	TE00 = 0, and count operation stops. The TCR00 register holds count value and stops. The TO00 output is not initialized but holds current status.
	The TOE00 bit is cleared to 0 and value is set to the TO00 bit.	The TO00 pin outputs the TO00 set level.
TAU stop	To hold the TO00 pin output level Clears the TO00 bit to 0 after the value to be held is set to the port register. When holding the TO00 pin output level is not necessary Setting not required.	The TO00 pin output level is held by port function.
	The TAU0EN bit of the PER0 register is cleared to 0.	Power-off status All circuits are initialized and SFR of each channel is also initialized. (The TO00 bit is cleared to 0 and the TO00 pin is set to port mode).

Operation is resumed.

6.8.4 Operation as input pulse interval measurement

The count value can be captured at the Tl_{mn} valid edge and the interval of the pulse input to Tl_{mn} can be measured. In addition, the count value can be captured by using software operation (TS_{mn} = 1) as a capture trigger while the TE_{mn} bit is set to 1.

The pulse interval can be calculated by the following expression.

$$Tl_{mn} \text{ input pulse interval} = \text{Period of count clock} \times ((10000H \times TSR_{mn}:OVF) + (\text{Capture value of } TDR_{mn} + 1))$$

Caution The Tl_{mn} pin input is sampled using the operating clock selected with the CKS_{mn} bit of timer mode register mn (TMR_{mn}), so an error of up to one operating clock cycle occurs.

Timer count register mn (TCR_{mn}) operates as an up counter in the capture mode.

When the channel start trigger bit (TS_{mn}) of timer channel start register m (TS_m) is set to 1, the TCR_{mn} register counts up from 0000H in synchronization with the count clock.

When the Tl_{mn} pin input valid edge is detected, the count value of the TCR_{mn} register is transferred (captured) to timer data register mn (TDR_{mn}) and, at the same time, the TCR_{mn} register is cleared to 0000H, and the INTT_{mn} is output. If the counter overflows at this time, the OVF bit of timer status register mn (TSR_{mn}) is set to 1. If the counter does not overflow, the OVF bit is cleared. After that, the above operation is repeated.

As soon as the count value has been captured to the TDR_{mn} register, the OVF bit of the TSR_{mn} register is updated depending on whether the counter overflows during the measurement period. Therefore, the overflow status of the captured value can be checked.

If the counter reaches a full count for two or more periods, it is judged to be an overflow occurrence, and the OVF bit of the TSR_{mn} register is set to 1. However, a normal interval value cannot be measured for the OVF bit, if two or more overflows occur.

Set the STS_{mn2} to STS_{mn0} bits of the TMR_{mn} register to 001B to use the valid edges of Tl_{mn} as a start trigger and a capture trigger.

Figure 6-53. Block Diagram of Operation as Input Pulse Interval Measurement

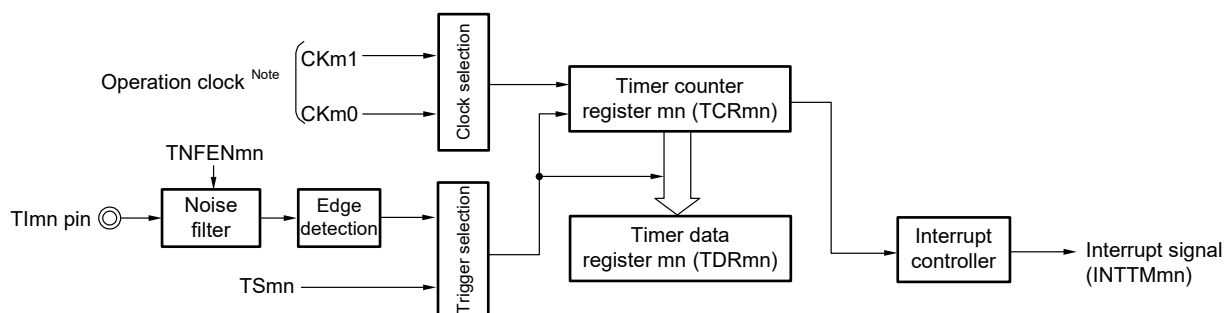

Note When channels 1 and 3, the clock can be selected from CK_{m0}, CK_{m1}, CK_{m2} and CK_{m3}.

Remark m: Unit number (m = 0, 1), n: Channel number (n = 0 to 7)

Figure 6-54. Example of Basic Timing of Operation as Input Pulse Interval Measurement (MDmn0 = 0)

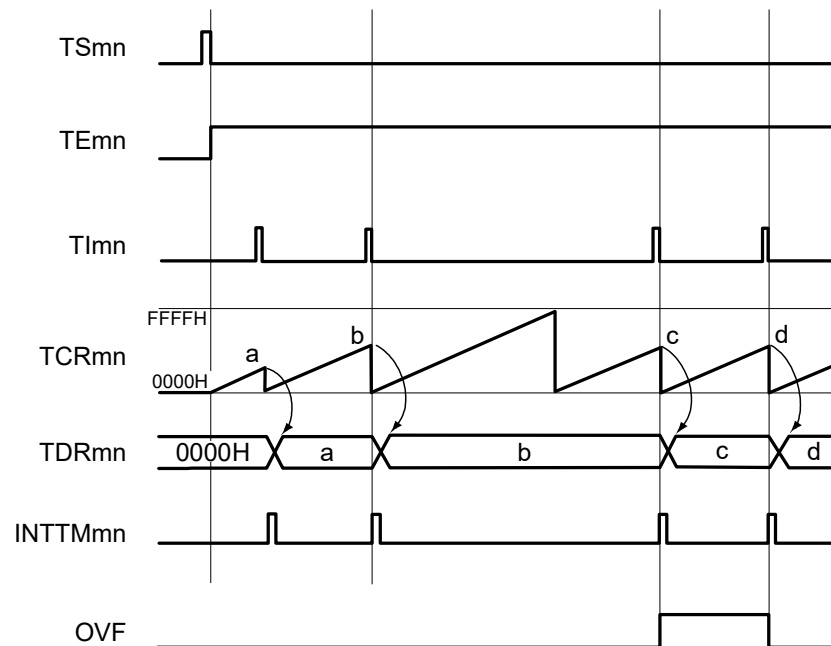

- Remarks**
1. m: Unit number (m = 0, 1)n: Channel number (n = 0 to 7)
 2. TSmn: Bit n of timer channel start register m (TSm)
 TE mn: Bit n of timer channel enable status register m (TEm)
 TImn: TImn pin input signal
 TCRmn: Timer count register mn (TCRmn)
 TDRmn: Timer data register mn (TDRmn)
 OVF: Bit 0 of timer status register mn (TSRmn)

Figure 6-55. Example of Set Contents of Registers to Measure Input Pulse Interval

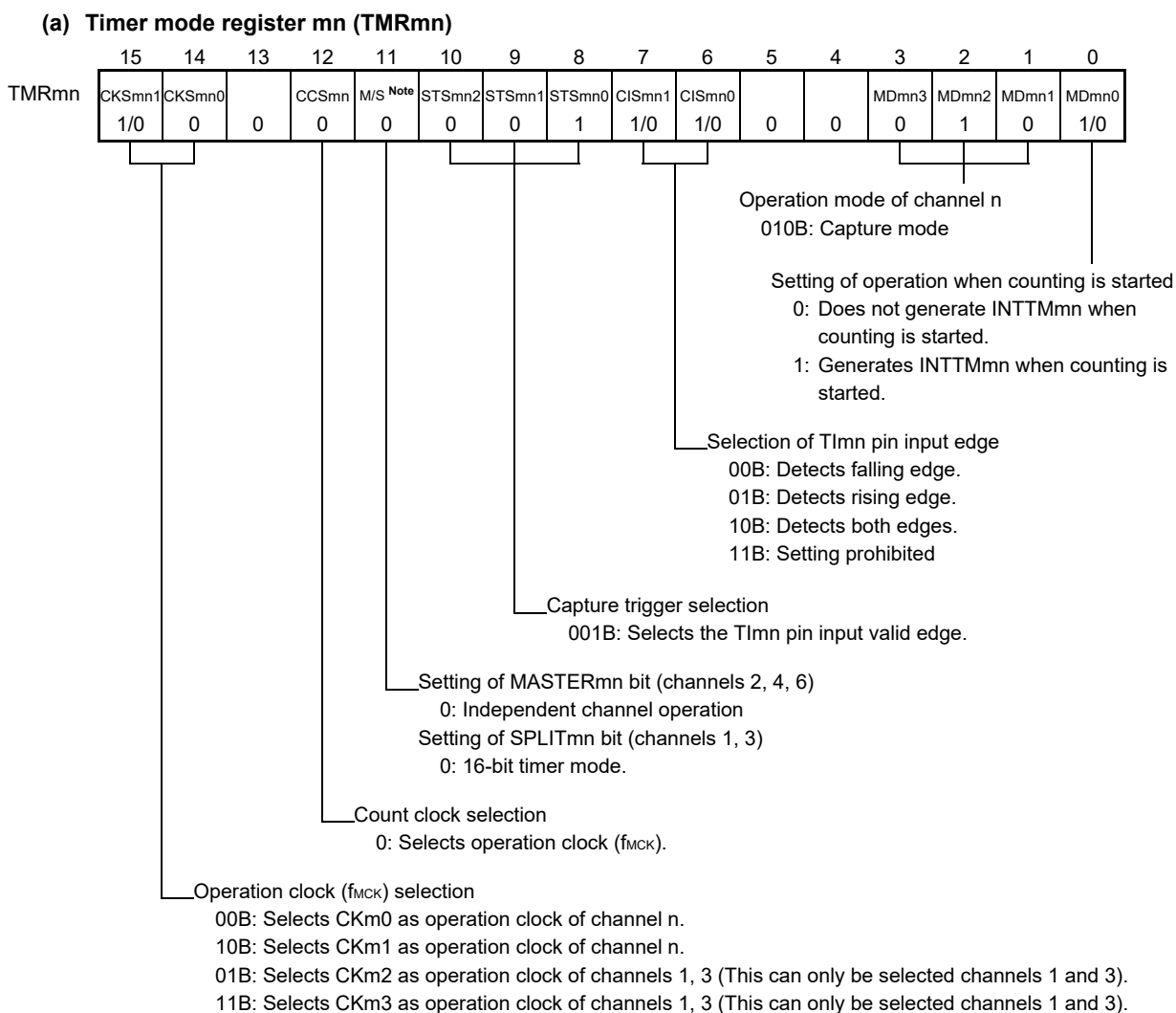

(b) Timer output register m (TOM)

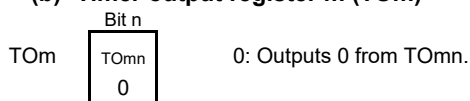

(c) Timer output enable register m (TOEm)

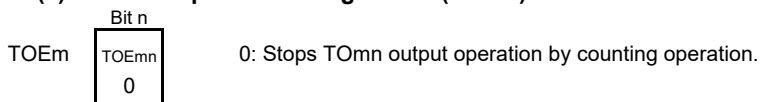

(d) Timer output level register m (TOLm)

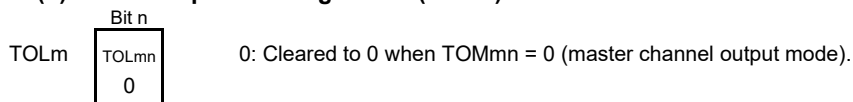

(e) Timer output mode register m (TOMm)

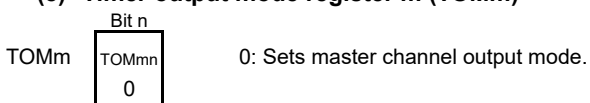

Note TMRm2, TMRm4, TMRm6: MASTERmn bit
 TMRm1, TMRm3: SPLITmn bit
 TMRm0, TMRm5, TMRm7: Fixed to 0

Remark m: Unit number (m = 0, 1), n: Channel number (n = 0 to 7)

Figure 6-56. Operation Procedure When Input Pulse Interval Measurement Function Is Used

	Software Operation	Hardware Status
TAU default setting		Power-off status (Clock supply is stopped and writing to each register is disabled.)
	Sets the TAUmEN bit of peripheral enable register 0 (PER0) to 1.	Power-on status. Each channel stops operating. (Clock supply is started and writing to each register is enabled.)
	Sets timer clock select register m (TPSm). Determines clock frequencies of CKm0 to CKm3.	
Channel default setting	Sets the corresponding bit of the noise filter enable registers 1, 2 (NFEN1, NFEN2) to 0 (off) or 1 (on). Sets timer mode register mn (TMRmn) (determines operation mode of channel).	Channel stops operating. (Clock is supplied and some power is consumed.)
Operation start	Sets TSmn bit to 1. The TSmn bit automatically returns to 0 because it is a trigger bit.	TEmn = 1, and count operation starts. Timer count register mn (TCRmn) is cleared to 0000H. When the MDmn0 bit of the TMRmn register is 1, INTTMmn is generated.
During operation	Set values of only the CISmn1 and CISmn0 bits of the TMRmn register can be changed. The TDRmn register can always be read. The TCRmn register can always be read. The TSRmn register can always be read. Set values of the TOMmn, TOLmn, TOMn, and TOEmn bits cannot be changed.	Counter (TCRmn) counts up from 0000H. When the valid edge of the TImn pin input is detected or the TSmn bit is set to 1, the count value is transferred (captured) to timer data register mn (TDRmn). At the same time, the TCRmn register is cleared to 0000H, and the INTTMmn signal is generated. If an overflow occurs at this time, the OVF bit of timer status register mn (TSRmn) is set; if an overflow does not occur, the OVF bit is cleared. After that, the above operation is repeated.
Operation stop	The TTmn bit is set to 1. The TTmn bit automatically returns to 0 because it is a trigger bit.	TEmn = 0, and count operation stops. The TCRmn register holds count value and stops. The OVF bit of the TSRmn register is also held.
TAU stop	The TAUmEN bit of the PER0 register is cleared to 0.	Power-off status All circuits are initialized and SFR of each channel is also initialized.

Operation is resumed.

Remark m: Unit number (m = 0, 1), n: Channel number (n = 0 to 7)

6.8.5 Operation as input signal high-/low-level width measurement

Caution When using a channel to implement the LIN-bus, set bit 1 (ISC1) of the input switch control register (ISC) to 1. In the following descriptions, read TImn as RxD2.

By starting counting at one edge of the TImn pin input and capturing the number of counts at another edge, the signal width (high-level width/low-level width) of TImn can be measured. The signal width of TImn can be calculated by the following expression.

$$\text{Signal width of TImn input} = \text{Period of count clock} \times ((10000\text{H} \times \text{TSRmn: OVF}) + (\text{Capture value of TDRmn} + 1))$$

Caution The TImn pin input is sampled using the operating clock selected with the CKSmn bit of timer mode register mn (TMRmn), so an error equivalent to one operation clock occurs.

Timer count register mn (TCRmn) operates as an up counter in the capture & one-count mode.

When the channel start trigger bit (TSmn) of timer channel start register m (TSm) is set to 1, the TEmn bit is set to 1 and the TImn pin start edge detection wait status is set.

When the TImn pin input start edge (rising edge of the TImn pin input when the high-level width is to be measured) is detected, the counter counts up from 0000H in synchronization with the count clock. When the valid capture edge (falling edge of the TImn pin input when the high-level width is to be measured) is detected later, the count value is transferred to timer data register mn (TDRmn) and, at the same time, INTTMmn is output. If the counter overflows at this time, the OVF bit of timer status register mn (TSRmn) is set to 1. If the counter does not overflow, the OVF bit is cleared. The TCRmn register stops at the value "value transferred to the TDRmn register + 1", and the TImn pin start edge detection wait status is set. After that, the above operation is repeated.

As soon as the count value has been captured to the TDRmn register, the OVF bit of the TSRmn register is updated depending on whether the counter overflows during the measurement period. Therefore, the overflow status of the captured value can be checked.

If the counter reaches a full count for two or more periods, it is judged to be an overflow occurrence, and the OVF bit of the TSRmn register is set to 1. However, a normal interval value cannot be measured for the OVF bit, if two or more overflows occur.

Whether the high-level width or low-level width of the TImn pin is to be measured can be selected by using the CISmn1 and CISmn0 bits of the TMRmn register.

Because this function is used to measure the signal width of the TImn pin input, the TSmn bit cannot be set to 1 while the TEmn bit is 1.

CISmn1, CISmn0 of TMRmn register = 10B: Low-level width is measured.

CISmn1, CISmn0 of TMRmn register = 11B: High-level width is measured.

Figure 6-57. Block Diagram of Operation as Input Signal High-/Low-Level Width Measurement

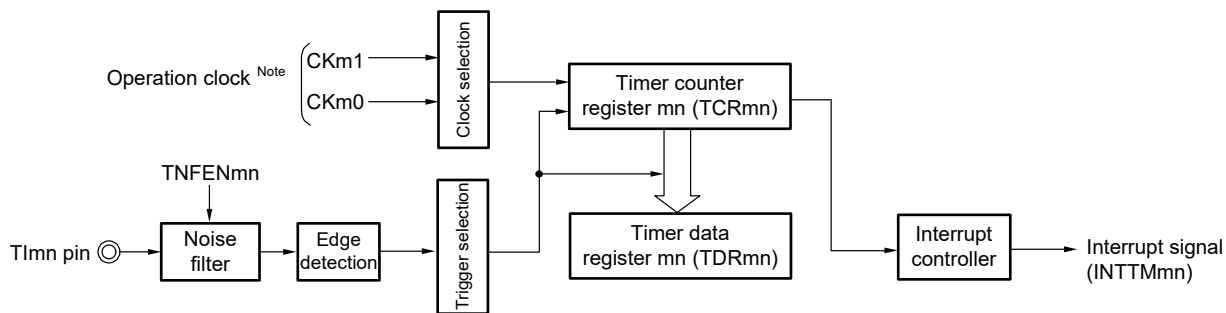

Note For channels 1 and 3, the clock can be selected from CK m0, CK m1, CK m2 and CK m3.

Figure 6-58. Example of Basic Timing of Operation as Input Signal High-/Low-Level Width Measurement

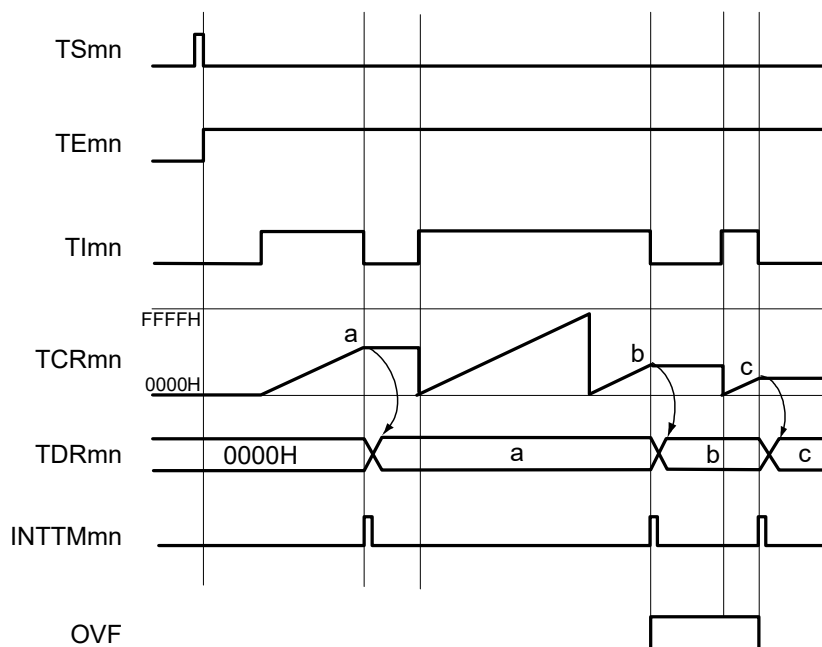

- Remarks**
1. m: Unit number (m = 0, 1), n: Channel number (n = 0 to 7)
 2. TS mn: Bit n of timer channel start register m (TS m)
 - TE mn: Bit n of timer channel enable status register m (TE m)
 - TI mn: TI mn pin input signal
 - TCR mn: Timer count register mn (TCR mn)
 - TDR mn: Timer data register mn (TDR mn)
 - OVF: Bit 0 of timer status register mn (TSR mn)

Figure 6-59. Example of Set Contents of Registers to Measure Input Signal High-/Low-Level Width

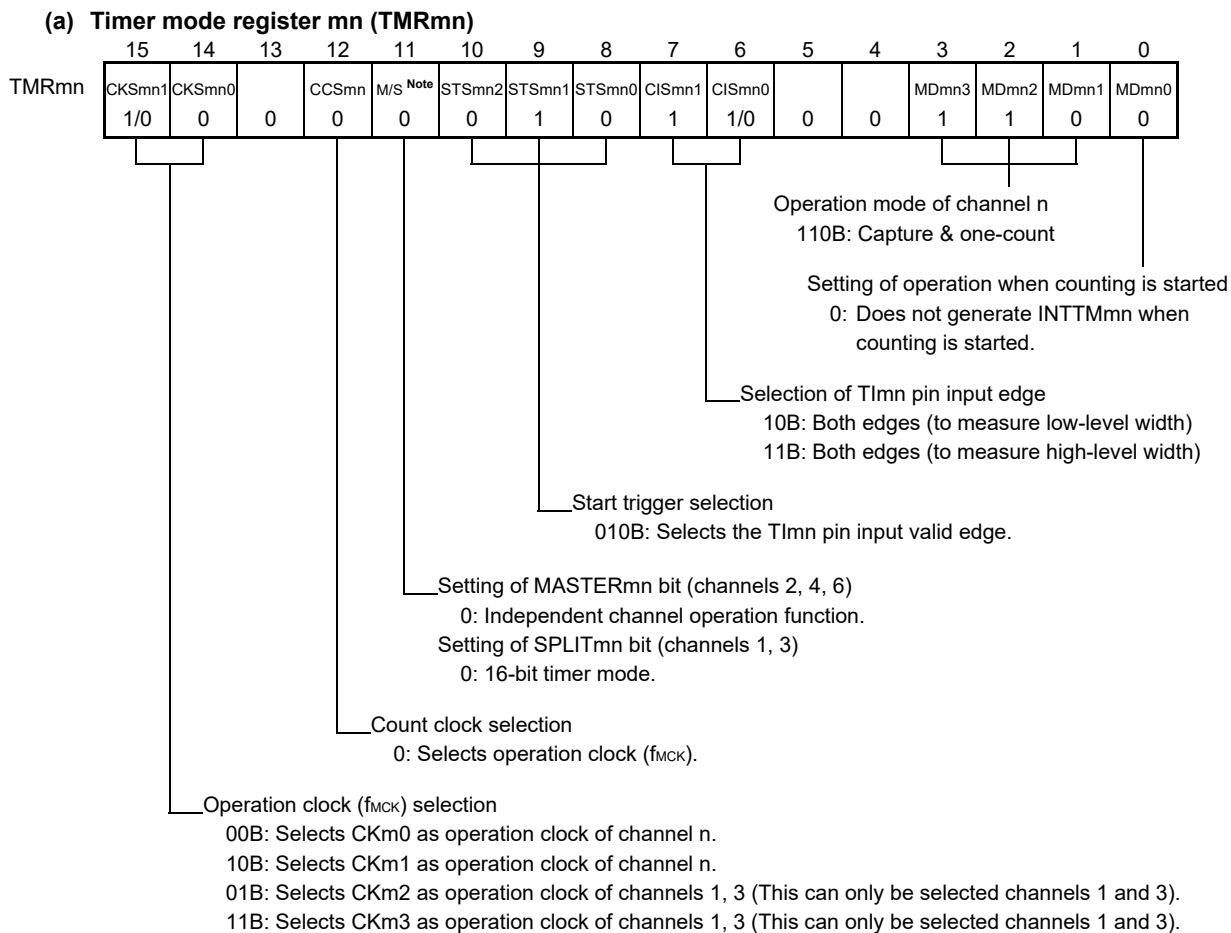

(b) Timer output register m (TOM)

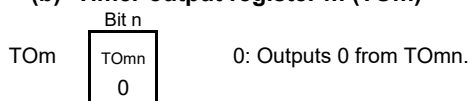

(c) Timer output enable register m (TOEm)

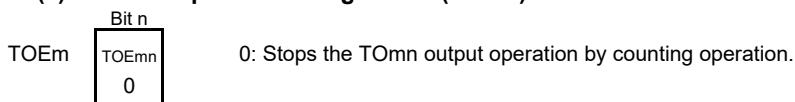

(d) Timer output level register m (TOLm)

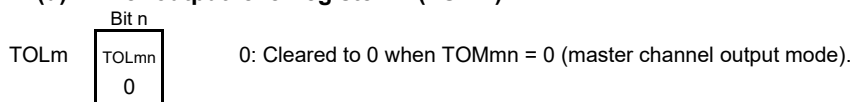

(e) Timer output mode register m (TOMm)

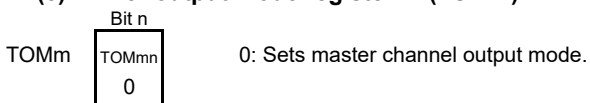

Note TMRm2, TMRm4, TMRm6: MASTERmn bit
 TMRm1, TMRm3: SPLITmn bit
 TMRm0, TMRm5, TMRm7: Fixed to 0

Remark m: Unit number (m = 0, 1), n: Channel number (n = 0 to 7)

Figure 6-60. Operation Procedure When Input Signal High-/Low-Level Width Measurement Function Is Used

	Software Operation	Hardware Status
TAU default setting		Power-off status (Clock supply is stopped and writing to each register is disabled.)
	Sets the TAUmEN bit of peripheral enable register 0 (PER0) to 1.	Power-on status. Each channel stops operating. (Clock supply is started and writing to each register is enabled.)
	Sets timer clock select register m (TPSm). Determines clock frequencies of CKm0 to CKm3.	
Channel default setting	Sets the corresponding bit of the noise filter enable registers 1, 2 (NFEN1, NFEN2) to 0 (off) or 1 (on). Sets timer mode register mn (TMRmn) (determines operation mode of channel). Clears the TOEmn bit to 0 and stops operation of TOMn.	Channel stops operating. (Clock is supplied and some power is consumed.)
Operation start	Sets the TSmn bit to 1. The TSmn bit automatically returns to 0 because it is a trigger bit.	TEmn = 1, and the TImn pin start edge detection wait status is set.
	Detects the TImn pin input count start valid edge.	Clears timer count register mn (TCRmn) to 0000H and starts counting up.
During operation	Set value of the TDRmn register can always be read. The TCRmn register can always be read. The TSRmn register can always be read. Set values of the TMRmn register, TOMmn, TOLmn, TOMn, and TOEmn bits cannot be changed.	When the TImn pin start edge is detected, the counter (TCRmn) counts up from 0000H. If a capture edge of the TImn pin is detected, the count value is transferred to timer data register mn (TDRmn) and INTTMmn is generated. If an overflow occurs at this time, the OVF bit of timer status register mn (TSRmn) is set; if an overflow does not occur, the OVF bit is cleared. The TCRmn register stops the count operation until the next TImn pin start edge is detected.
Operation stop	The TTmn bit is set to 1. The TTmn bit automatically returns to 0 because it is a trigger bit.	TEmn = 0, and count operation stops. The TCRmn register holds count value and stops. The OVF bit of the TSRmn register is also held.
TAU stop	The TAUmEN bit of the PER0 register is cleared to 0.	Power-off status All circuits are initialized and SFR of each channel is also initialized.

Operation is resumed.

Remark m: Unit number (m = 0, 1), n: Channel number (n = 0 to 7)

6.8.6 Operation as delay counter

It is possible to start counting down when the valid edge of the TImn pin input is detected (an external event), and then generate INTTMmn (a timer interrupt) after any specified interval.

It is also possible to start counting down and generate INTTMmn (timer interrupt) at any interval by setting TSmn to 1 by software while TEMn = 1.

The interrupt generation period can be calculated by the following expression.

$$\text{Generation period of INTTMmn (timer interrupt)} = \text{Period of count clock} \times (\text{Set value of TDRmn} + 1)$$

Timer count register mn (TCRmn) operates as a down counter in the one-count mode.

When the channel start trigger bit (TSmn, TSHm1, TSHm3) of timer channel start register m (TSM) is set to 1, the TEMn, TEHm1, TEHm3 bits are set to 1 and the TImn pin input valid edge detection wait status is set.

Timer count register mn (TCRmn) starts operating upon TImn pin input valid edge detection and loads the value of timer data register mn (TDRmn). The TCRmn register counts down from the value of the TDRmn register it has loaded, in synchronization with the count clock. When TCRmn = 0000H, it outputs INTTMmn and stops counting until the next TImn pin input valid edge is detected.

The TDRmn register can be rewritten at any time. The new value of the TDRmn register becomes valid from the next period.

Figure 6-61. Block Diagram of Operation as Delay Counter

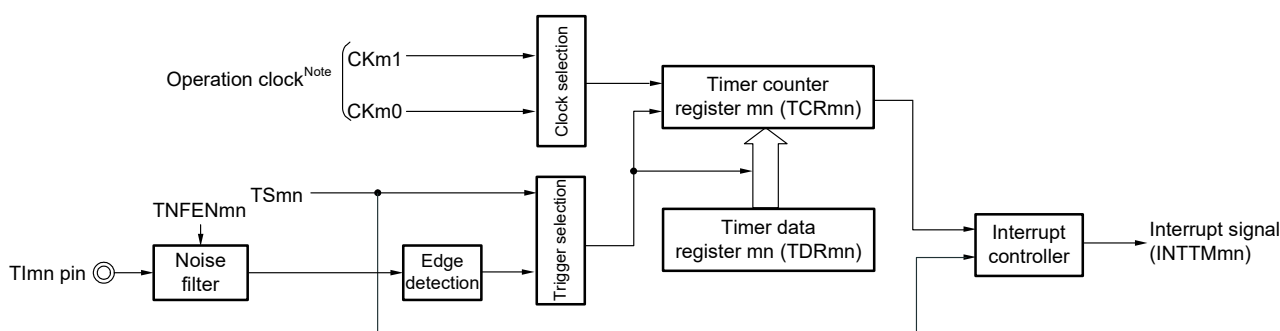

Note For using channels 1 and 3, the clock can be selected from CKm0, CKm1, CKm2 and CKm3.

Remark m: Unit number (m = 0, 1), n: Channel number (n = 0 to 7)

Figure 6-62. Example of Basic Timing of Operation as Delay Counter

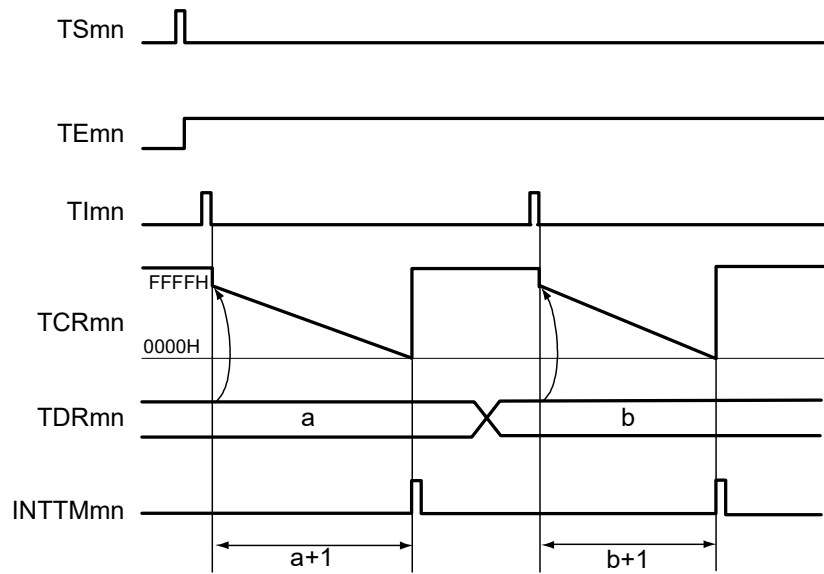

- Remarks 1.** m: Unit number (m = 0, 1), n: Channel number (n = 0 to 7)
- 2. TSmn: Bit n of timer channel start register m (TSm)
 - TE mn: Bit n of timer channel enable status register m (TEm)
 - TImn: TImn pin input signal
 - TCRmn: Timer count register mn (TCRmn)
 - TDRmn: Timer data register mn (TDRmn)

Figure 6-63. Example of Set Contents of Registers to Delay Counter (1/2)

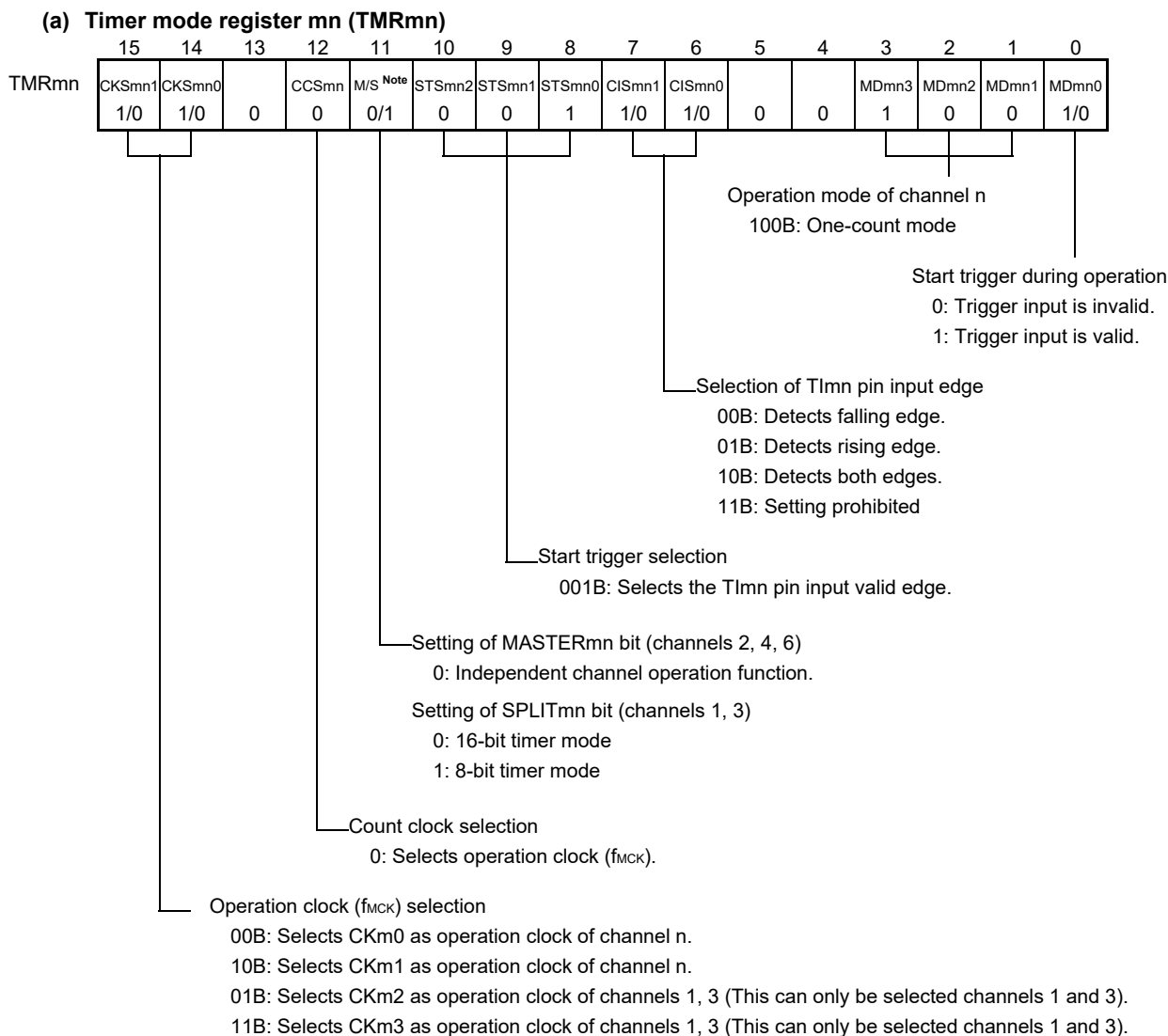

(b) Timer output register m (TOM)

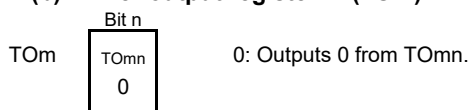

(c) Timer output enable register m (TOEm)

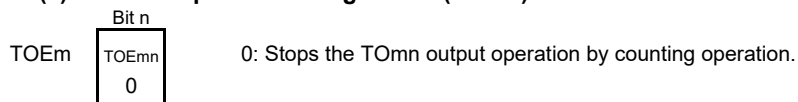

Note TMRm2, TMRm4, TMRm6: MASTERmn bit
 TMRm1, TMRm3: SPLITmn bit
 TMRm0, TMRm5, TMRm7: Fixed to 0

Remark m: Unit number (m = 0, 1), n: Channel number (n = 0 to 7)

Figure 6-63. Example of Set Contents of Registers to Delay Counter (2/2)**(d) Timer output level register m (TOLm)**

TOLm

Bit n
TOLmn
0

 0: Cleared to 0 when TOMmn = 0 (master channel output mode).

(e) Timer output mode register m (TOMm)

TOMm

Bit n
TOMmn
0

 0: Sets master channel output mode.

Remark m: Unit number (m = 0, 1), n: Channel number (n = 0 to 7)

Figure 6-64. Operation Procedure When Delay Counter Function Is Used

	Software Operation	Hardware Status
TAU default setting		Power-off status (Clock supply is stopped and writing to each register is disabled.)
	Sets the TAUmEN bit of peripheral enable register 0 (PER0) to 1.	Power-on status. Each channel stops operating. (Clock supply is started and writing to each register is enabled.)
	Sets timer clock select register m (TPSm). Determines clock frequencies of CKm0 to CKm3.	
Channel default setting	Sets the corresponding bit of the noise filter enable registers 1, 2 (NFEN1, NFEN2) to 0 (off) or 1 (on). Sets timer mode register mn (TMRmn) (determines operation mode of channel). INTTMmn output delay is set to timer data register mn (TDRmn). Clears the TOEmn bit to 0 and stops operation of TOMn.	Channel stops operating. (Clock is supplied and some power is consumed.)
Operation start	Sets the TSmn bit to 1. The TSmn bit automatically returns to 0 because it is a trigger bit.	TEmn = 1, and the start trigger detection (the valid edge of the TImn pin input is detected or the TSmn bit is set to 1) wait status is set.
	The counter starts counting down by the next start trigger detection. <ul style="list-style-type: none"> • Detects the TImn pin input valid edge. • Sets the TSmn bit to 1 by the software. 	Value of the TDRmn register is loaded to the timer count register mn (TCRmn).
During operation	Set value of the TDRmn register can be changed. The TCRmn register can always be read. The TSRmn register is not used.	The counter (TCRmn) counts down. When the count value of TCRmn reaches 0000H, the INTTMmn output is generated, and the count operation stops until the next start trigger detection (the valid edge of the TImn pin input is detected or the TSmn bit is set to 1).
Operation stop	The TTmn bit is set to 1. The TTmn bit automatically returns to 0 because it is a trigger bit.	TEmn = 0, and count operation stops. The TCRmn register holds count value and stops.
TAU stop	The TAUmEN bit of the PER0 register is cleared to 0.	Power-off status All circuits are initialized and SFR of each channel is also initialized.

Operation is resumed.

Remark m: Unit number (m = 0, 1), n: Channel number (n = 0 to 7)

6.9 Simultaneous Channel Operation Function of Timer Array Unit

6.9.1 Operation as one-shot pulse output function

By using two channels as a set, a one-shot pulse having any delay pulse width can be generated from the signal input to the TImn pin.

The delay time and pulse width can be calculated by the following expressions.

$\text{Delay time} = \{\text{Set value of TDRmn (master)} + 2\} \times \text{Count clock period}$ $\text{Pulse width} = \{\text{Set value of TDRmp (slave)}\} \times \text{Count clock period}$

The master channel operates in the one-count mode and counts the delays. Timer count register mn (TCRmn) of the master channel starts operating upon start trigger detection and loads the value of timer data register mn (TDRmn).

The TCRmn register counts down from the value of the TDRmn register it has loaded, in synchronization with the count clock. When TCRmn = 0000H, it outputs INTTMmn and stops counting until the next start trigger is detected.

The slave channel operates in the one-count mode and counts the pulse width. The TCRmp register of the slave channel starts operation using INTTMmn of the master channel as a start trigger, and loads the value of the TDRmp register. The TCRmp register counts down from the value of the TDRmp register it has loaded, in synchronization with the count value. When count value = 0000H, it outputs INTTMmp and stops counting until the next start trigger (INTTMmn of the master channel) is detected. The output level of TOmp becomes active one count clock after generation of INTTMmn from the master channel, and inactive when TCRmp = 0000H.

Instead of using the TImn pin input, a one-shot pulse can also be output using the software operation (TSmn = 1) as a start trigger.

Caution The timing of loading of timer data register mn (TDRmn) of the master channel is different from that of the TDRmp register of the slave channel. If the TDRmn and TDRmp registers are rewritten during operation, therefore, an illegal waveform is output. Rewrite the TDRmn register after INTTMmn is generated and the TDRmp register after INTTMmp is generated.

Remark m: Unit number (m = 0, 1), n: Channel number (n = 0, 2, 4, 6)
p: Slave channel number (n < p ≤ 7)

Figure 6-65. Block Diagram of Operation as One-Shot Pulse Output Function

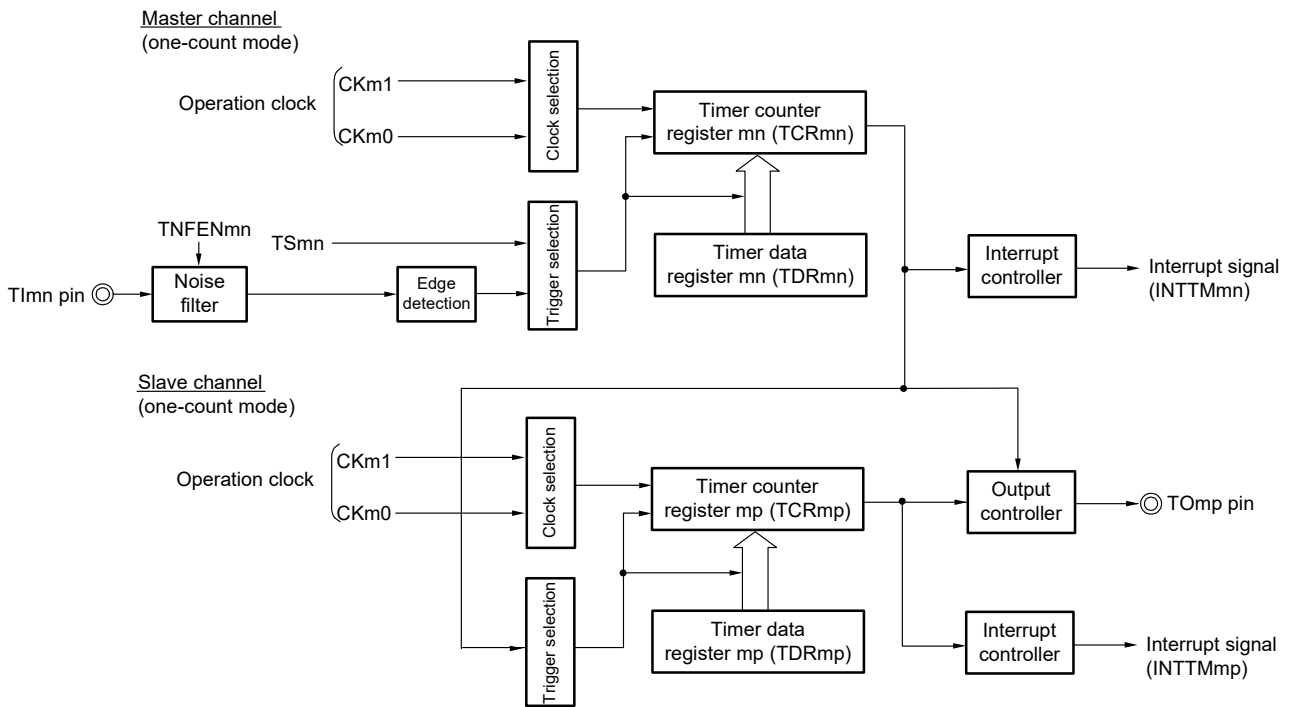

Remark m: Unit number (m = 0, 1), n: Channel number (n = 0, 2, 4, 6)
 p: Slave channel number (n < p ≤ 7)

Figure 6-66. Example of Basic Timing of Operation as One-Shot Pulse Output Function

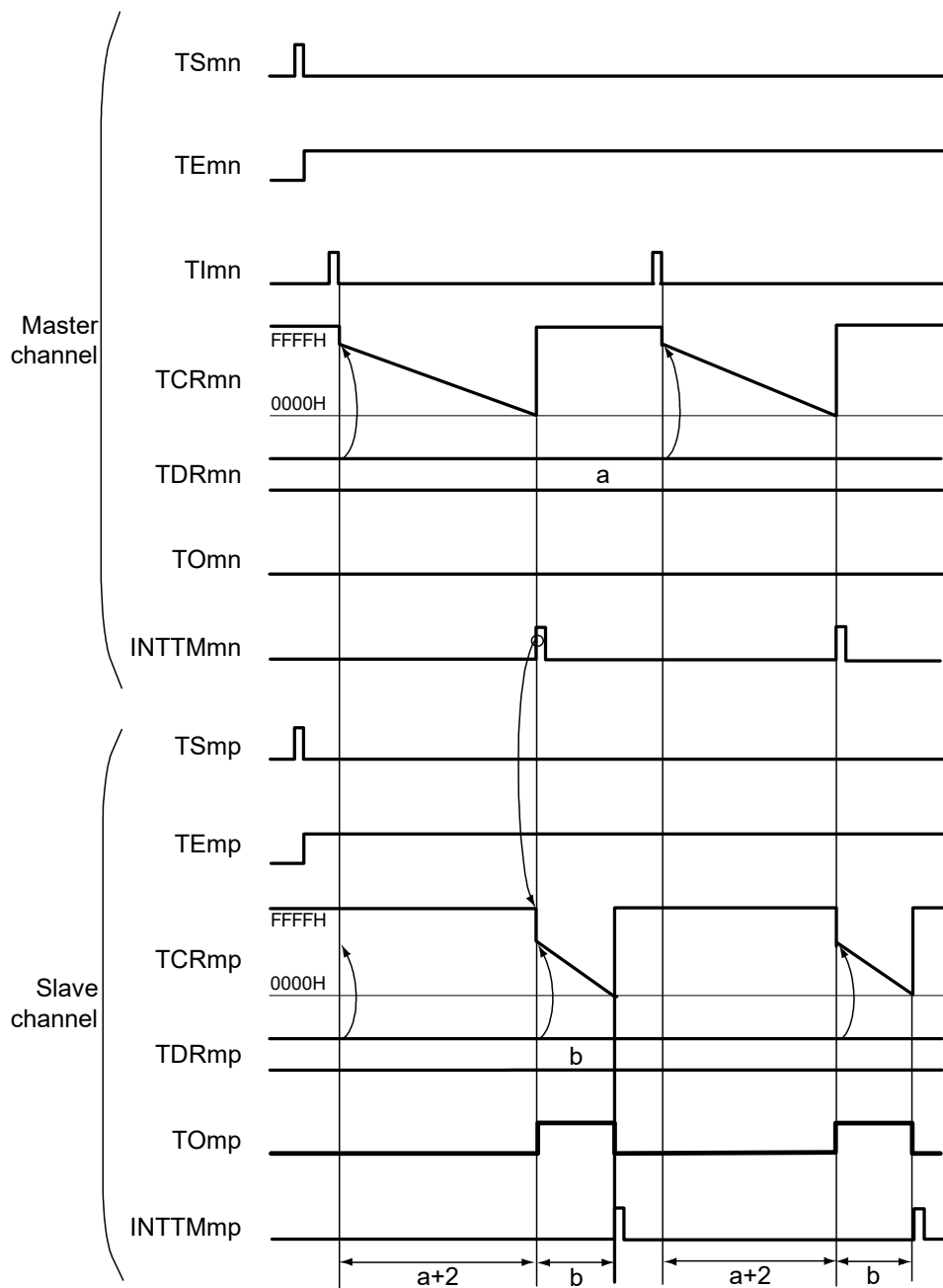

- Remarks**
1. m: Unit number ($m = 0, 1$), n: Channel number ($n = 0, 2, 4, 6$)
p: Slave channel number ($n < p \leq 7$)
 2. TSmn, TSmp: Bit n, p of timer channel start register m (TSM)
TEmn, TEmp: Bit n, p of timer channel enable status register m (TEM)
TImn, TImp: TImn and TImp pins input signal
TCRmn, TCRmp: Timer count registers mn, mp (TCRmn, TCRmp)
TDRmn, TDRmp: Timer data registers mn, mp (TDRmn, TDRmp)
TOmn, TOmp: TOmn and TOmp pins output signal

Figure 6-67. Example of Set Contents of Registers When One-Shot Pulse Output Function Is Used (Master Channel)

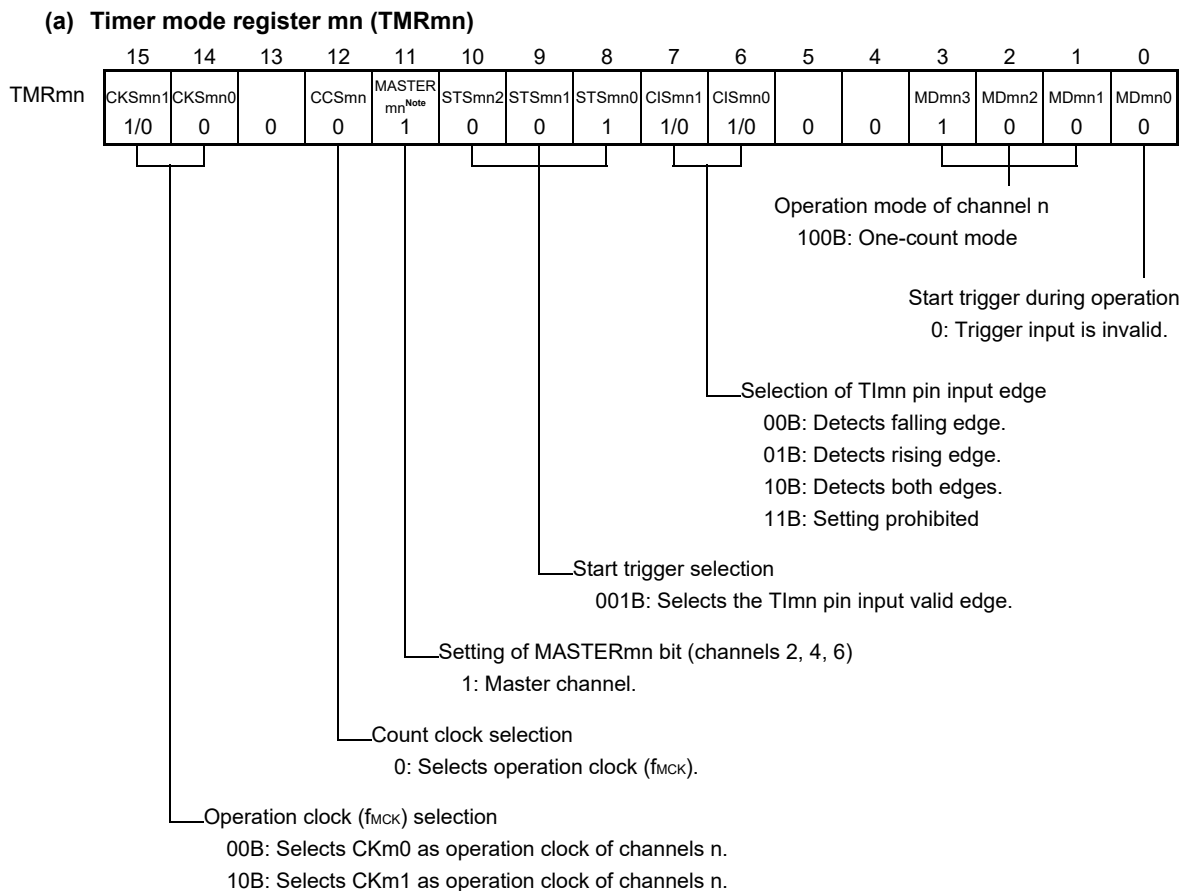

(b) Timer output register m (TOM)

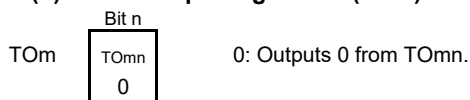

(c) Timer output enable register m (TOEm)

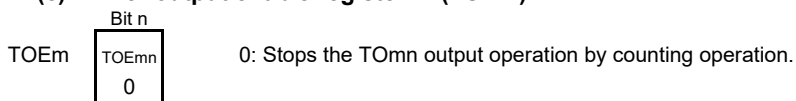

(d) Timer output level register m (TOLm)

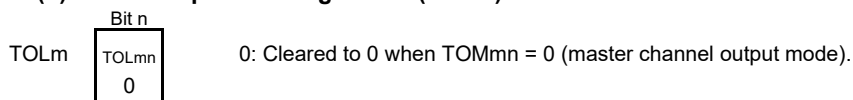

(e) Timer output mode register m (TOMm)

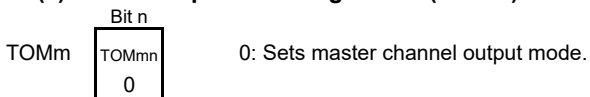

Note TMRm2, TMRm4, TMRm6: MASTERmn = 1
 TMRm0: Fixed to 0

Remark m: Unit number (m = 0, 1), n: Channel number (n = 0, 2, 4, 6)

Figure 6-68. Example of Set Contents of Registers When One-Shot Pulse Output Function Is Used (Slave Channel)

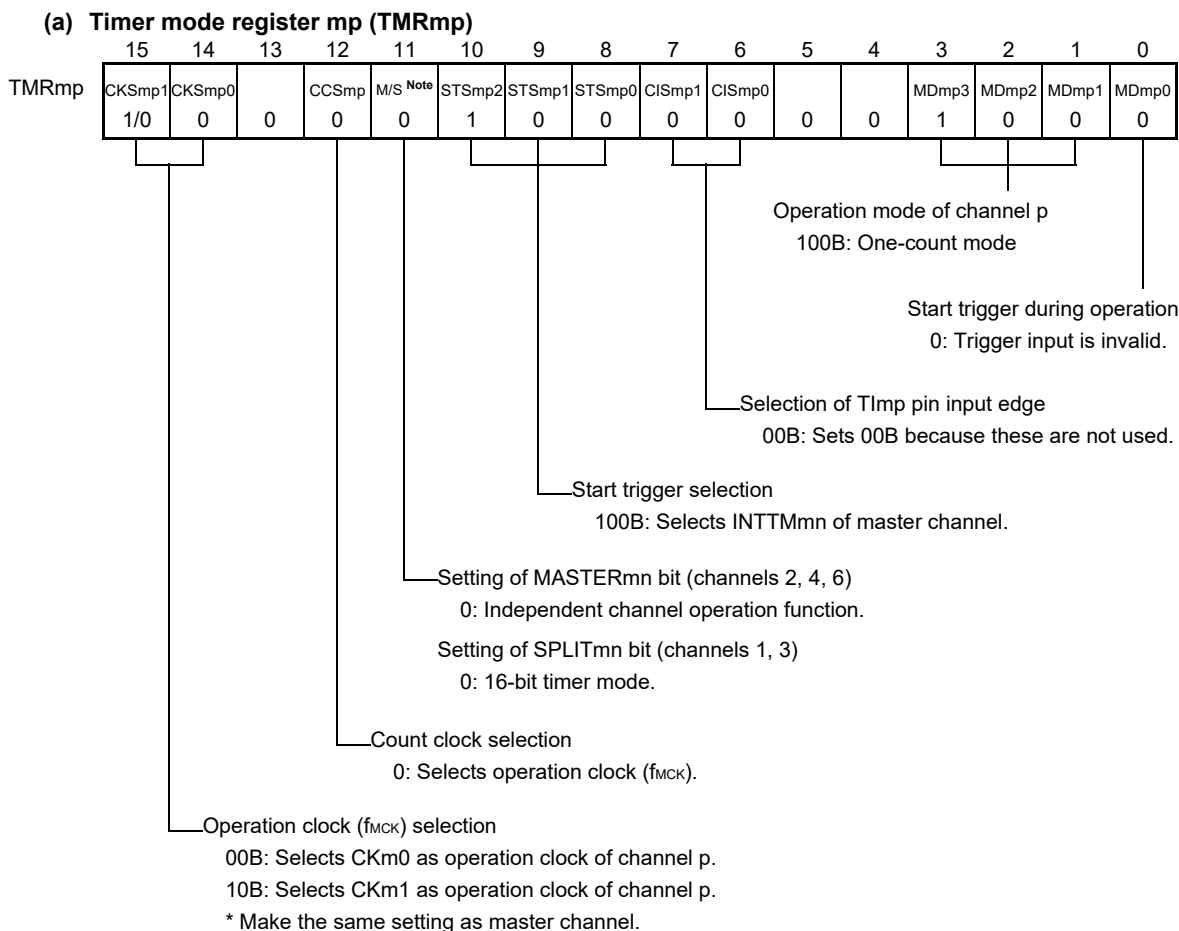

(b) **Timer output register m (TOM)**

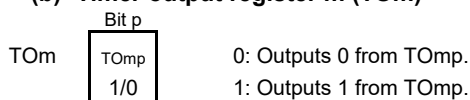

(c) **Timer output enable register m (TOEm)**

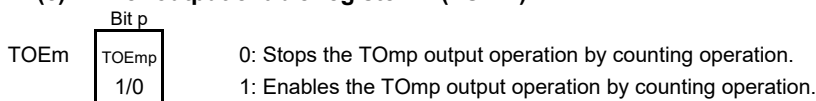

(d) **Timer output level register m (TOLm)**

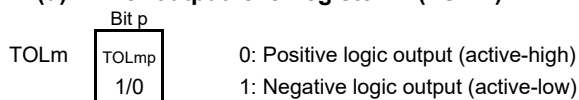

(e) **Timer output mode register m (TOMm)**

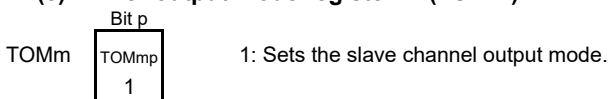

Note TMRm2, TMRm4, TMRm6: MASTERmn bit

TMRm1, TMRm3: SPLITmp bit

TMRm5, TMRm7: Fixed to 0

Remark m: Unit number (m = 0, 1), n: Channel number (n = 0, 2, 4, 6)

p: Slave channel number (n < p ≤ 7)

Figure 6-69. Operation Procedure of One-Shot Pulse Output Function (1/2)

	Software Operation	Hardware Status
TAU default setting		Power-off status (Clock supply is stopped and writing to each register is disabled.)
	Sets the TAUmEN bit of peripheral enable registers 0 (PER0) to 1.	Power-on status. Each channel stops operating. (Clock supply is started and writing to each register is enabled.)
	Sets timer clock select register m (TPSm). Determines clock frequencies of CKm0 and CKm1.	
Channel default setting	Sets the corresponding bit of the noise filter enable registers 1, 2 (NFEN1, NFEN2) to 1. Sets timer mode register mn, mp (TMRmn, TMRmp) of two channels to be used (determines operation mode of channels). An output delay is set to timer data register mn (TDRmn) of the master channel, and a pulse width is set to the TDRmp register of the slave channel.	Channel stops operating. (Clock is supplied and some power is consumed.)
	Sets slave channel. The TOMmp bit of timer output mode register m (TOMm) is set to 1 (slave channel output mode). Sets the TOLmp bit. Sets the TOmp bit and determines default level of the TOmp output. Sets the TOEmp bit to 1 and enables operation of TOmp. Clears the port register and port mode register to 0.	The TOmp pin goes into Hi-Z output state. The TOmp default setting level is output when the port mode register is in output mode and the port register is 0. TOmp does not change because channel stops operating. The TOmp pin outputs the TOmp set level.

(Note and Remark are listed on the next page.)

Figure 6-69. Operation Procedure of One-Shot Pulse Output Function (2/2)

	Software Operation	Hardware Status
Operation start	Sets the TOEmp bit (slave) to 1 (only when operation is resumed). The TSmn (master) and TSmp (slave) bits of timer channel start register m (TSM) are set to 1 at the same time. The TSmn and TSmp bits automatically return to 0 because they are trigger bits.	The TEMn and TEm bits are set to 1 and the master channel enters the start trigger detection (the valid edge of the TImn pin input is detected or the TSmn bit of the master channel is set to 1) wait status. Counter stops operating.
	Count operation of the master channel is started by start trigger detection of the master channel. <ul style="list-style-type: none"> • Detects the TImn pin input valid edge. • Sets the TSmn bit of the master channel to 1 by software ^{Note}. Note Do not set the TSmn bit of the slave channel to 1.	Master channel starts counting.
During operation	Set values of only the CISmn1 and CISmn0 bits of the TMRmn register can be changed. Set values of the TMRmp, TDRmn, TDRmp registers, TOMmn, TOMmp, TOLmn, and TOLmp bits cannot be changed. The TCRmn and TCRmp registers can always be read. The TSRmn and TSRmp registers are not used. Set values of the TOm and TOEm registers by slave channel can be changed.	Master channel loads the value of the TDRmn register to timer count register mn (TCRmn) by the start trigger detection (the valid edge of the TImn pin input is detected or the TSmn bit of the master channel is set to 1), and the counter starts counting down. When the count value reaches TCRmn = 0000H, the INTTMmn output is generated, and the counter stops until the next start trigger detection. The slave channel, triggered by INTTMmn of the master channel, loads the value of the TDRmp register to the TCRmp register, and the counter starts counting down. The output level of TOmp becomes active one count clock after generation of INTTMmn from the master channel. It becomes inactive when TCRmp = 0000H, and the counting operation is stopped. After that, the above operation is repeated.
Operation stop	The TTmn (master) and TTmp (slave) bits are set to 1 at the same time. The TTmn and TTmp bits automatically return to 0 because they are trigger bits.	TEMn, TEm = 0, and count operation stops. The TCRmn and TCRmp registers hold count value and stop. The TOmp output is not initialized but holds current status.
	The TOEmp bit of slave channel is cleared to 0 and value is set to the TOmp bit.	The TOmp pin outputs the TOmp set level.
TAU stop	To hold the TOmp pin output level Clears the TOmp bit to 0 after the value to be held is set to the port register.	The TOmp pin output level is held by port function.
	When holding the TOmp pin output level is not necessary Setting not required. The TAUmEN bit of the PER0 register is cleared to 0.	Power-off status All circuits are initialized and SFR of each channel is also initialized. (The TOmp bit is cleared to 0 and the TOmp pin is set to port mode.)

Operation is resumed.

Remark m: Unit number (m = 0, 1), n: Channel number (n = 0, 2, 4, 6)
p: Slave channel number (n < p ≤ 7)

6.9.2 Operation as PWM function

Two channels can be used as a set to generate a pulse of any period and duty factor.

The period and duty factor of the output pulse can be calculated by the following expressions.

$$\text{Pulse period} = \{\text{Set value of TDRmn (master)} + 1\} \times \text{Count clock period}$$

$$\text{Duty factor [\%]} = \{\text{Set value of TDRmp (slave)}\} / \{\text{Set value of TDRmn (master)} + 1\} \times 100$$

0% output: Set value of TDRmp (slave) = 0000H

100% output: Set value of TDRmp (slave) \geq {Set value of TDRmn (master) + 1}

Remark The duty factor exceeds 100% if the set value of TDRmp (slave) > (set value of TDRmn (master) + 1), it summarizes to 100% output.

The master channel operates in the interval timer mode. If the channel start trigger bit (TSmn) of timer channel start register m (TSM) is set to 1, an interrupt (INTTMmn) is output, the value set to timer data register mn (TDRmn) is loaded to timer count register mn (TCRmn), and the counter counts down in synchronization with the count clock. When the counter reaches 0000H, INTTMmn is output, the value of the TDRmn register is loaded again to the TCRmn register, and the counter counts down. This operation is repeated until the channel stop trigger bit (TTmn) of timer channel stop register m (TTM) is set to 1.

If two channels are used to output a PWM waveform, the period until the master channel counts down to 0000H is the PWM output (TOmp) cycle.

The slave channel operates in one-count mode. By using INTTMmn from the master channel as a start trigger, the TCRmp register loads the value of the TDRmp register and the counter counts down to 0000H. When the counter reaches 0000H, it outputs INTTMmp and waits until the next start trigger (INTTMmn from the master channel) is generated.

If two channels are used to output a PWM waveform, the period until the slave channel counts down to 0000H is the PWM output (TOmp) duty.

PWM output (TOmp) goes to the active level one clock after the master channel generates INTTMmn and goes to the inactive level when the TCRmp register of the slave channel becomes 0000H.

Caution To rewrite both timer data register mn (TDRmn) of the master channel and the TDRmp register of the slave channel, a write access is necessary two times. The timing at which the values of the TDRmn and TDRmp registers are loaded to the TCRmn and TCRmp registers is upon occurrence of INTTMmn of the master channel. Thus, when rewriting is performed split before and after occurrence of INTTMmn of the master channel, the TOmp pin cannot output the expected waveform. To rewrite both the TDRmn register of the master and the TDRmp register of the slave, therefore, be sure to rewrite both the registers immediately after INTTMmn is generated from the master channel.

Remark m: Unit number (m = 0, 1), n: Channel number (n = 0, 2, 4, 6)
p: Slave channel number (n < p ≤ 7)

Figure 6-70. Block Diagram of Operation as PWM Function

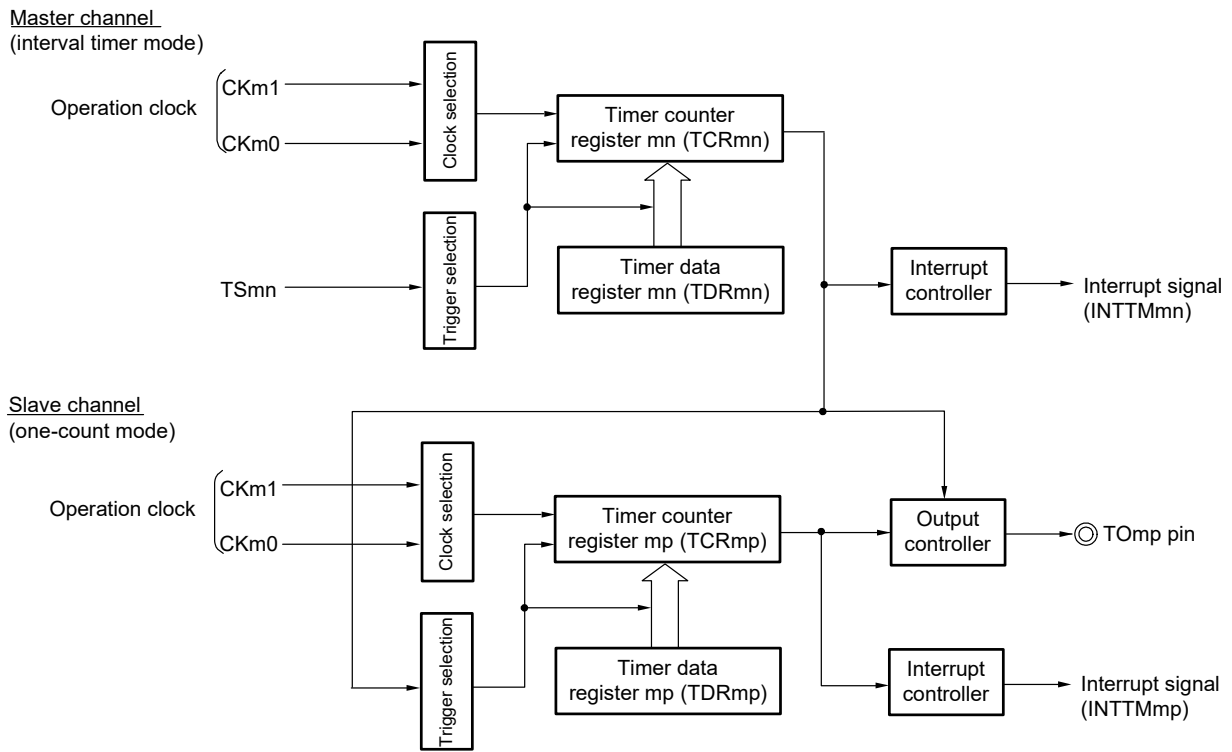

Remark m: Unit number (m = 0, 1), n: Channel number (n = 0, 2, 4, 6)
 p: Slave channel number (n < p ≤ 7)

Figure 6-71. Example of Basic Timing of Operation as PWM Function

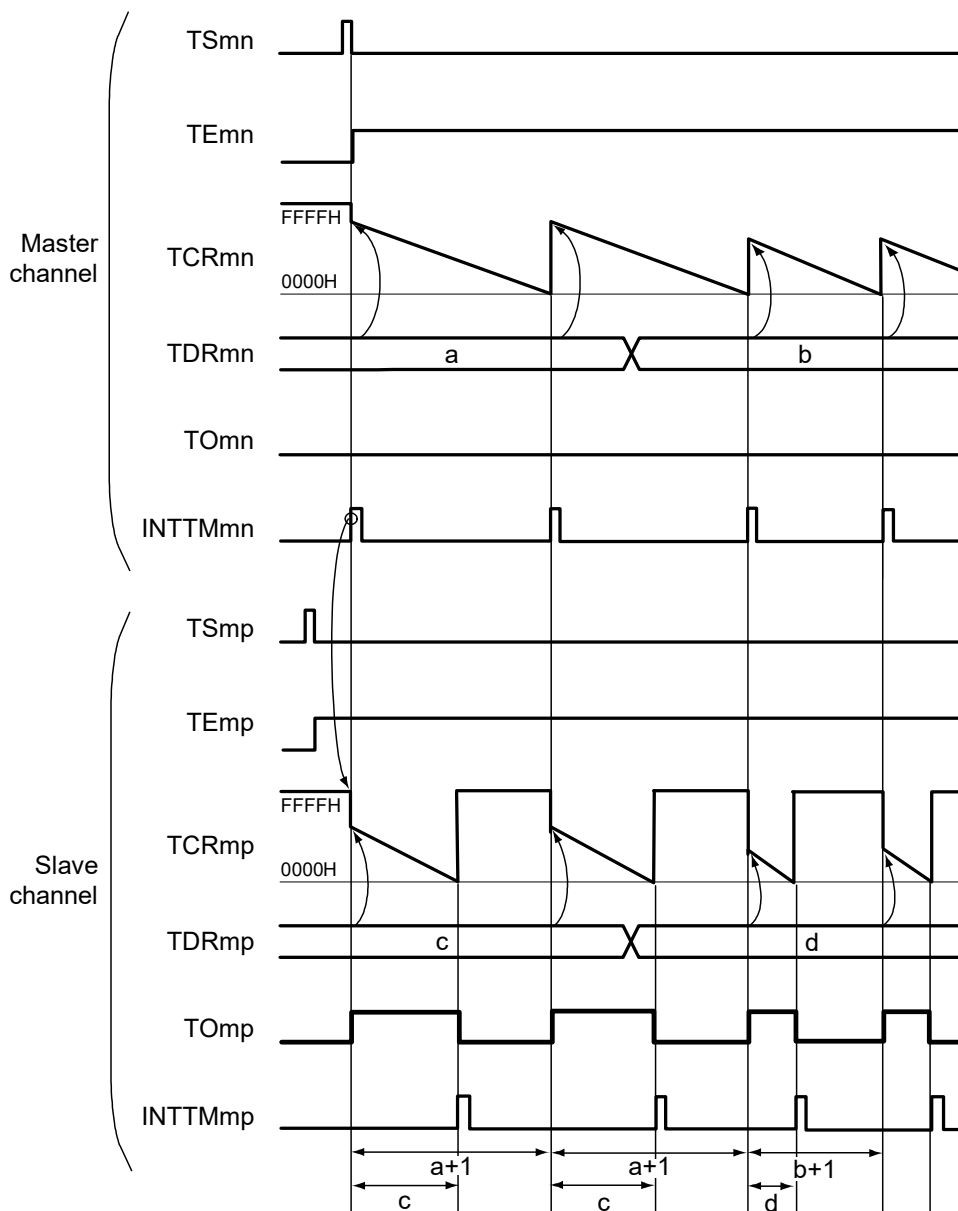

- Remark 1.** m: Unit number (m = 0, 1), n: Channel number (n = 0, 2, 4, 6)
 p: Slave channel number (n < p ≤ 7)
2. TSmn, TSmp: Bit n, p of timer channel start register m (TSM)

TEmn, TEmP: Bit n, p of timer channel enable status register m (TEM)

TCRmn, TCRmp: Timer count registers mn, mp (TCRmn, TCRmp)

TDRmn, TDRmp: Timer data registers mn, mp (TDRmn, TDRmp)

TOmn, TOmp: TOmn and TOmp pins output signal

Figure 6-72. Example of Set Contents of Registers When PWM Function (Master Channel) Is Used

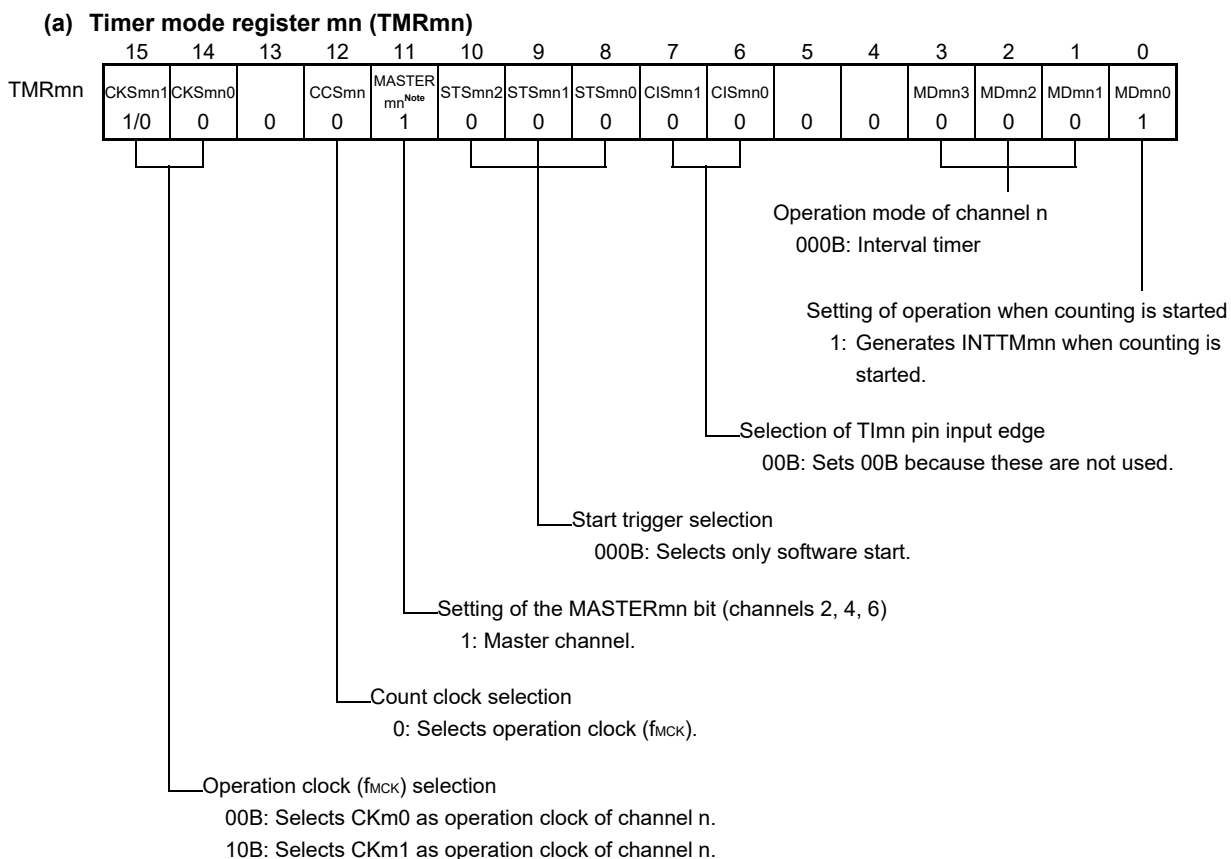

(b) Timer output register m (TOM)

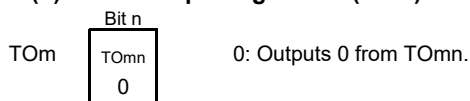

(c) Timer output enable register m (TOEm)

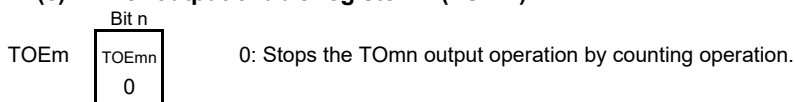

(d) Timer output level register m (TOLm)

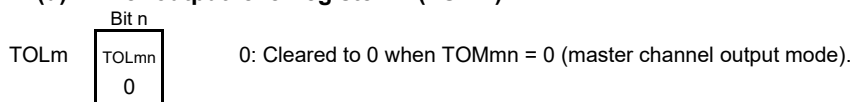

(e) Timer output mode register m (TOMm)

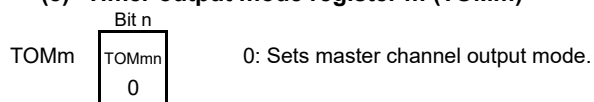

Note TMRm2, TMRm4, TMRm6: MASTERmn = 1
TMRm0: Fixed to 0

Remark m: Unit number (m = 0, 1), n: Channel number (n = 0, 2, 4, 6)

Figure 6-73. Example of Set Contents of Registers When PWM Function (Slave Channel) Is Used

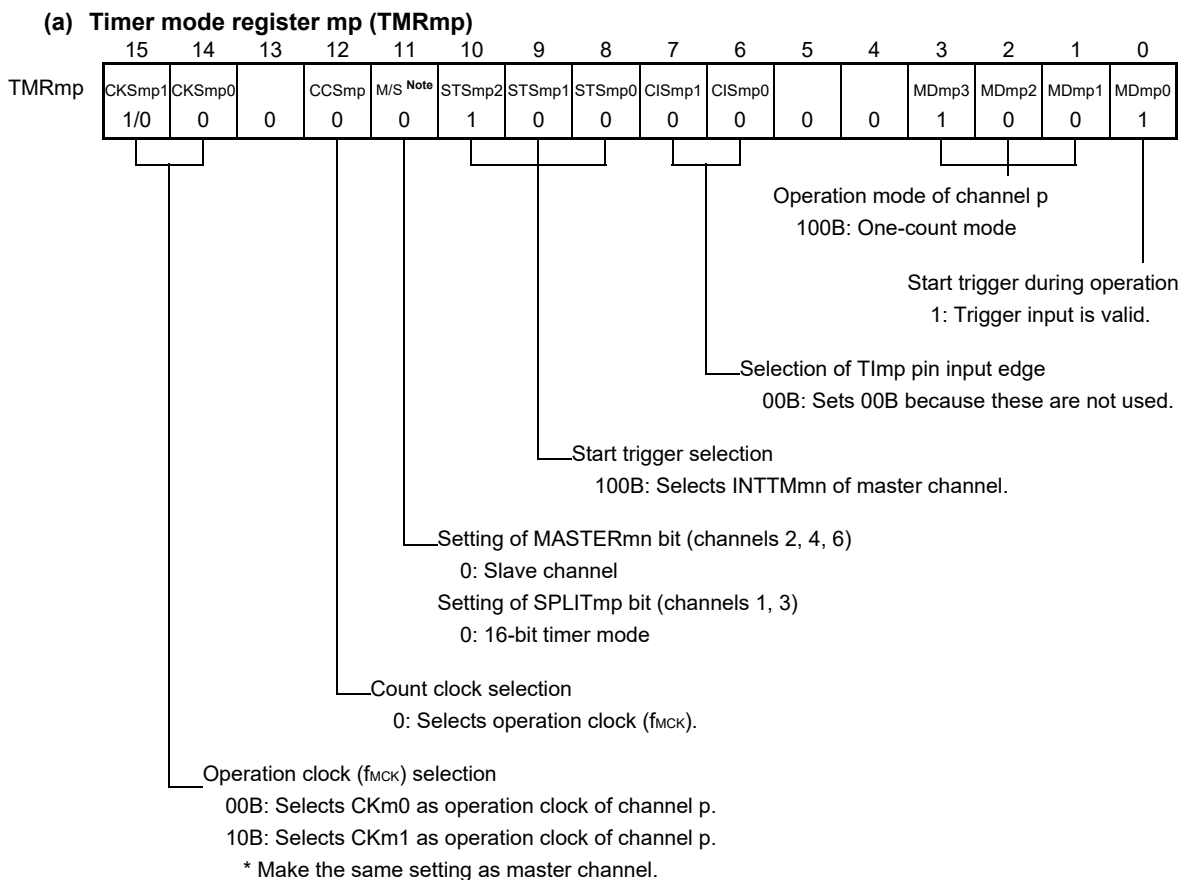

(b) Timer output register m (TOM)

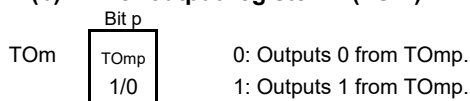

(c) Timer output enable register m (TOEm)

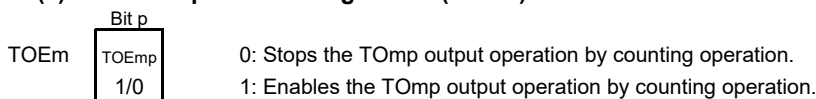

(d) Timer output level register m (TOLm)

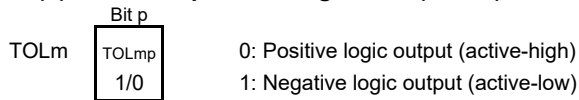

(e) Timer output mode register m (TOMm)

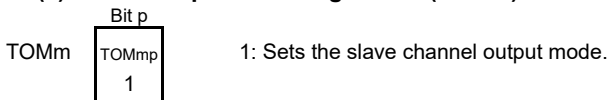

Note TMRm2, TMRm4, TMRm6: MASTERmn bit
 TMRm1, TMRm3: SPLITmp bit
 TMRm5, TMRm7: Fixed to 0

Remark m: Unit number (m = 0, 1), n: Channel number (n = 0, 2, 4, 6)
 p: Slave channel number (n < p ≤ 7)

Figure 6-74. Operation Procedure When PWM Function Is Used (1/2)

	Software Operation	Hardware Status
TAU default setting		Power-off status (Clock supply is stopped and writing to each register is disabled.)
	Sets the TAUmEN bit of peripheral enable register 0 (PER0) to 1. →	Power-on status. Each channel stops operating. (Clock supply is started and writing to each register is enabled.)
	Sets timer clock select register m (TPSm). Determines clock frequencies of CKm0 and CKm1.	
Channel default setting	Sets timer mode registers mn, mp (TMRmn, TMRmp) of two channels to be used (determines operation mode of channels). An interval (period) value is set to timer data register mn (TDRmn) of the master channel, and a duty factor is set to the TDRmp register of the slave channel.	Channel stops operating. (Clock is supplied and some power is consumed.)
	Sets slave channel. The TOMmp bit of timer output mode register m (TOMm) is set to 1 (slave channel output mode). Sets the TOLmp bit. Sets the TOmp bit and determines default level of the TOmp output. →	The TOmp pin goes into Hi-Z output state.
	Sets the TOEmp bit to 1 and enables operation of TOmp. →	The TOmp default setting level is output when the port mode register is in output mode and the port register is 0.
	Clears the port register and port mode register to 0. →	TOmp does not change because channel stops operating. The TOmp pin outputs the TOmp set level.

Figure 6-74. Operation Procedure When PWM Function Is Used (2/2)

	Software Operation	Hardware Status
Operation is resumed.	<p>Operation start</p> <p>Sets the TOEmp bit (slave) to 1 (only when operation is resumed).</p> <p>The TSmn (master) and TSmp (slave) bits of timer channel start register m (TSM) are set to 1 at the same time.</p> <p>The TSmn and TSmp bits automatically return to 0 because they are trigger bits.</p>	<p>TEmn = 1, TEmP = 1</p> <p>▶ When the master channel starts counting, INTTMmn is generated. Triggered by this interrupt, the slave channel also starts counting.</p>
	<p>During operation</p> <p>Set values of the TMRmn and TMRmp registers, TOMmn, TOMmp, TOLmn, and TOLmp bits cannot be changed.</p> <p>Set values of the TDRmn and TDRmp registers can be changed after INTTMmn of the master channel is generated.</p> <p>The TCRmn and TCRmp registers can always be read.</p> <p>The TSRmn and TSRmp registers are not used.</p>	<p>The counter of the master channel loads the TDRmn register value to timer count register mn (TCRmn), and counts down. When the count value reaches TCRmn = 0000H, INTTMmn output is generated. At the same time, the value of the TDRmn register is loaded to the TCRmn register, and the counter starts counting down again.</p> <p>At the slave channel, the value of the TDRmp register is loaded to the TCRmp register, triggered by INTTMmn of the master channel, and the counter starts counting down. The output level of TOmp becomes active one count clock after generation of the INTTMmn output from the master channel. It becomes inactive when TCRmp = 0000H, and the counting operation is stopped.</p> <p>After that, the above operation is repeated.</p>
	<p>Operation stop</p> <p>The TTmn (master) and TTmp (slave) bits are set to 1 at the same time.</p> <p>The TTmn and TTmp bits automatically return to 0 because they are trigger bits.</p>	<p>TEmn, TEmP = 0, and count operation stops.</p> <p>The TCRmn and TCRmp registers hold count value and stop.</p> <p>The TOmp output is not initialized but holds current status.</p>
	<p>The TOEmp bit of slave channel is cleared to 0 and value is set to the TOmp bit.</p>	<p>▶ The TOmp pin outputs the TOmp set level.</p>
<p>TAU stop</p> <p>To hold the TOmp pin output level</p> <p>Clears the TOmp bit to 0 after the value to be held is set to the port register.</p> <p>When holding the TOmp pin output level is not necessary</p> <p>Setting not required.</p>	<p>▶ The TOmp pin output level is held by port function.</p>	
<p>The TAUmEN bit of the PER0 register is cleared to 0.</p>	<p>▶ Power-off status</p> <p>All circuits are initialized and SFR of each channel is also initialized.</p> <p>(The TOmp bit is cleared to 0 and the TOmp pin is set to port mode.)</p>	

Remark m: Unit number (m = 0, 1), n: Channel number (n = 0, 2, 4, 6)
 p: Slave channel number (n < p ≤ 7)

6.9.3 Operation as multiple PWM output function

By extending the PWM function and using multiple slave channels, many PWM waveforms with different duty values can be output.

For example, when using two slave channels, the period and duty factor of an output pulse can be calculated by the following expressions.

$$\begin{aligned} \text{Pulse period} &= \{\text{Set value of TDRmn (master)} + 1\} \times \text{Count clock period} \\ \text{Duty factor 1 [\%]} &= \{\text{Set value of TDRmp (slave 1)}\} / \{\text{Set value of TDRmn (master)} + 1\} \times 100 \\ \text{Duty factor 2 [\%]} &= \{\text{Set value of TDRmq (slave 2)}\} / \{\text{Set value of TDRmn (master)} + 1\} \times 100 \end{aligned}$$

Remark Although the duty factor exceeds 100% if the set value of TDRmp (slave 1) > {set value of TDRmn (master) + 1} or if the {set value of TDRmq (slave 2)} > {set value of TDRmn (master) + 1}, it is summarized into 100% output.

Timer count register mn (TCRmn) of the master channel operates in the interval timer mode and counts the periods.

The TCRmp register of the slave channel 1 operates in one-count mode, counts the duty factor, and outputs a PWM waveform from the TOmp pin. The TCRmp register loads the value of timer data register mp (TDRmp), using INTTMmn of the master channel as a start trigger, and starts counting down. When TCRmp = 0000H, TCRmp outputs INTTMmp and stops counting until the next start trigger (INTTMmn of the master channel) has been input. The output level of TOmp becomes active one count clock after generation of INTTMmn from the master channel, and inactive when TCRmp = 0000H.

In the same way as the TCRmp register of the slave channel 1, the TCRmq register of the slave channel 2 operates in one-count mode, counts the duty factor, and outputs a PWM waveform from the TOMq pin. The TCRmq register loads the value of the TDRmq register, using INTTMmn of the master channel as a start trigger, and starts counting down. When TCRmq = 0000H, the TCRmq register outputs INTTMmq and stops counting until the next start trigger (INTTMmn of the master channel) has been input. The output level of TOMq becomes active one count clock after generation of INTTMmn from the master channel, and inactive when TCRmq = 0000H.

When channel 0 is used as the master channel as above, up to seven types of PWM signals can be output at the same time.

Caution To rewrite both timer data register mn (TDRmn) of the master channel and the TDRmp register of the slave channel 1, write access is necessary at least twice. Since the values of the TDRmn and TDRmp registers are loaded to the TCRmn and TCRmp registers after INTTMmn is generated from the master channel, if rewriting is performed separately before and after generation of INTTMmn from the master channel, the TOmp pin cannot output the expected waveform. To rewrite both the TDRmn register of the master and the TDRmp register of the slave, be sure to rewrite both the registers immediately after INTTMmn is generated from the master channel (This applies also to the TDRmq register of the slave channel 2).

Remark m: Unit number (m = 0, 1), n: Channel number (n = 0, 2, 4)
 p: Slave channel number 1, q: Slave channel number 2
 n < p < q ≤ 7 (Where p and q are integers greater than n)

Figure 6-75. Block Diagram of Operation as Multiple PWM Output Function (output two types of PWMs)

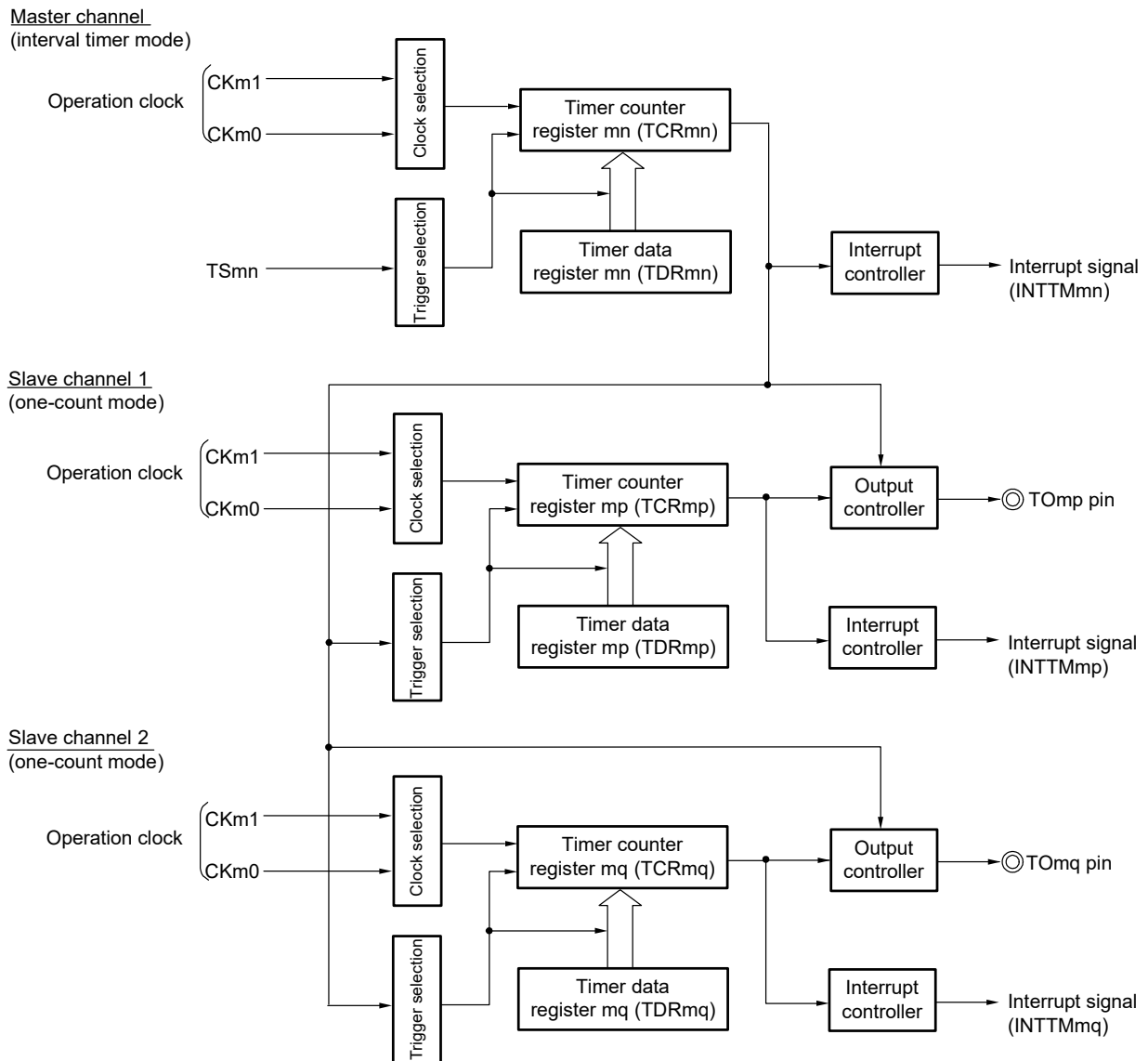

Remark m: Unit number (m = 0, 1), n: Channel number (n = 0, 2, 4)
 p: Slave channel number 1, q: Slave channel number 2
 n < p < q ≤ 7 (Where p and q are integers greater than n)

Figure 6-76. Example of Basic Timing of Operation as Multiple PWM Output Function (Output two types of PWMs)

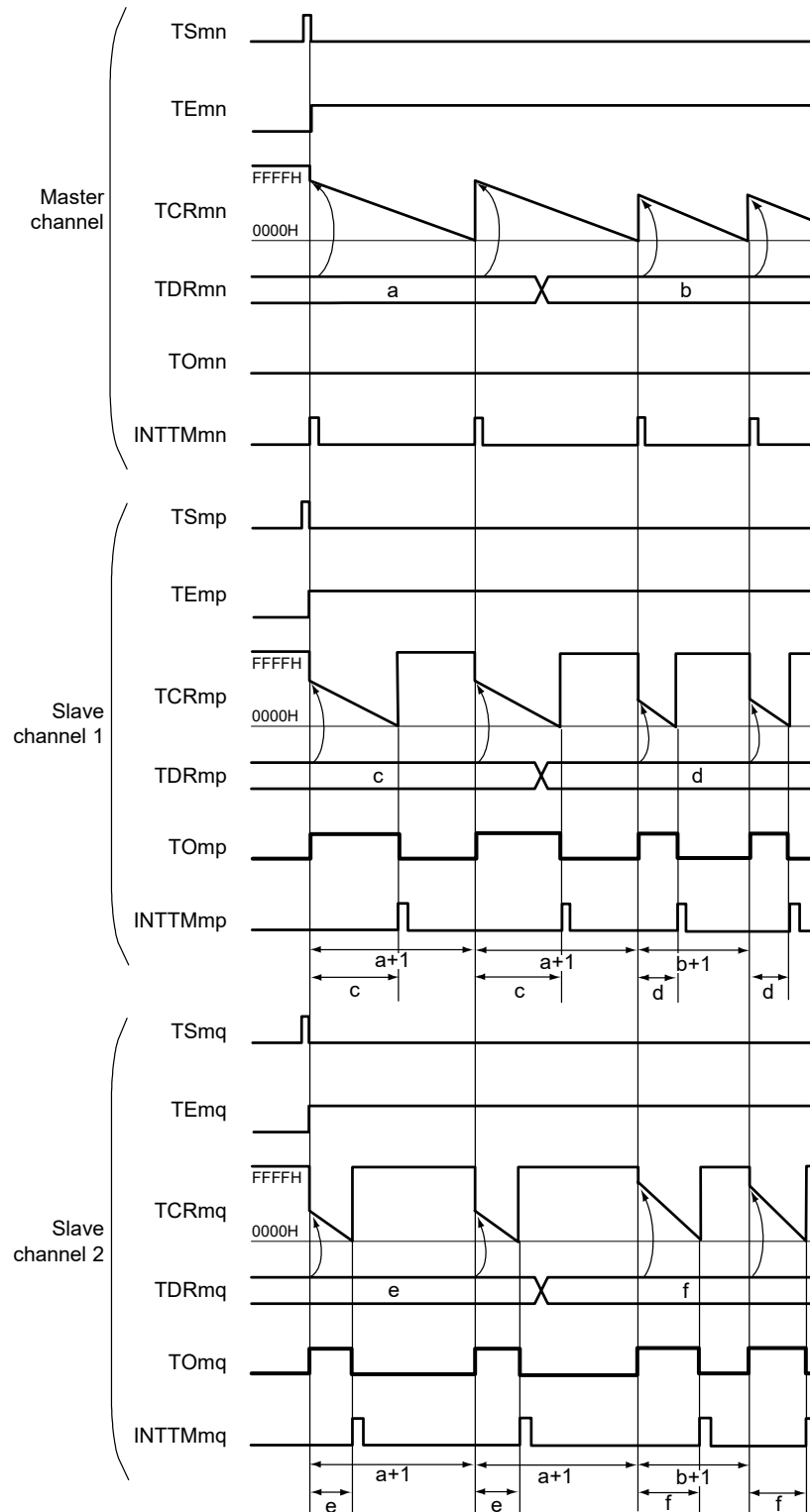

(Remarks are listed on the next page.)

- Remarks 1.** m: Unit number (m = 0, 1), n: Channel number (n = 0, 2, 4)
p: Slave channel number 1, q: Slave channel number 2
n < p < q ≤ 7 (Where p and q are integers greater than n)
- 2.** TSmn, TSmp, TSmq: Bit n, p, q of timer channel start register m (TSm)
TEmn, TEmq, TEmq: Bit n, p, q of timer channel enable status register m (TEm)
TCRmn, TCRmp, TCRmq: Timer count registers mn, mp, mq (TCRmn, TCRmp, TCRmq)
TDRmn, TDRmp, TDRmq: Timer data registers mn, mp, mq (TDRmn, TDRmp, TDRmq)
TOMn, TOmp, TOMq: TOMn, TOmp, and TOMq pins output signal

**Figure 6-77. Example of Set Contents of Registers
When Multiple PWM Output Function (Master Channel) Is Used**

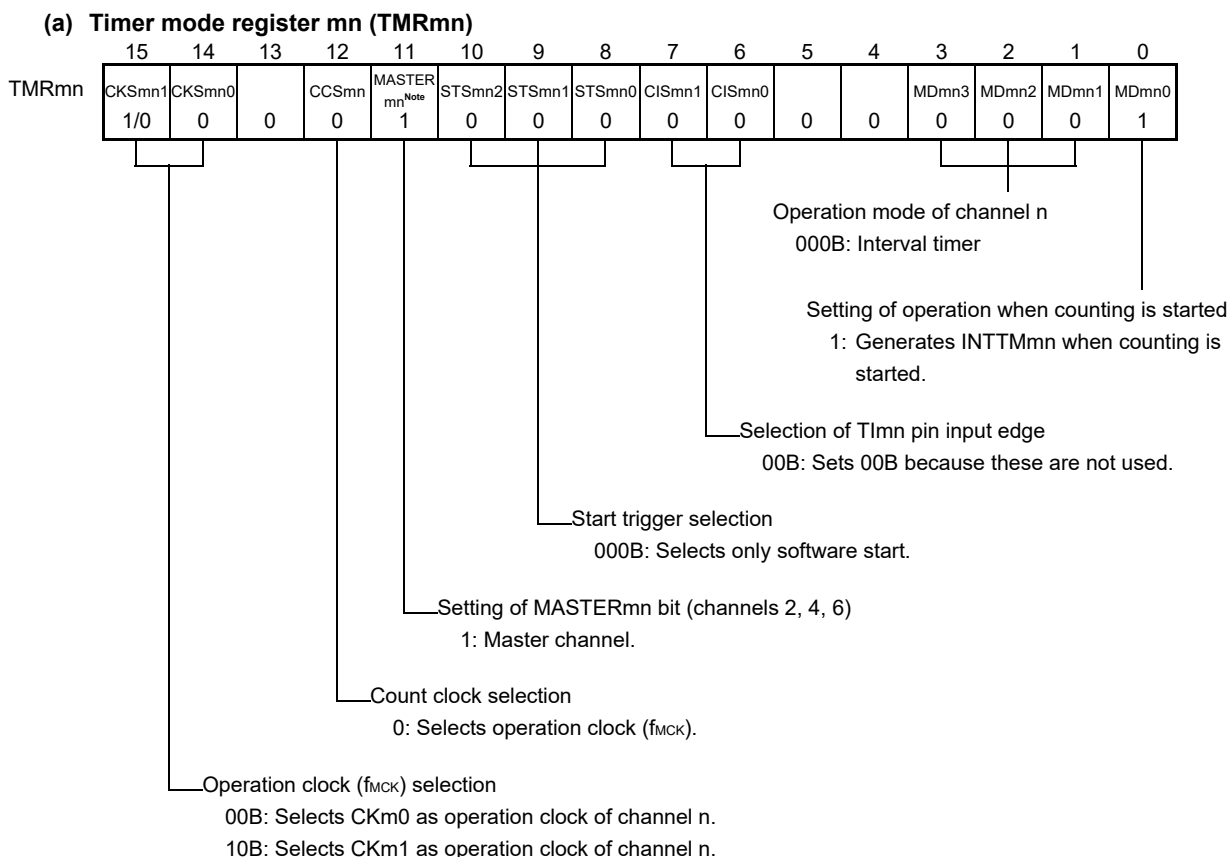

(b) **Timer output register m (TOM)**

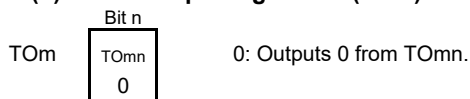

(c) **Timer output enable register m (TOEm)**

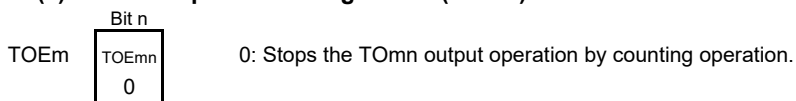

(d) **Timer output level register m (TOLm)**

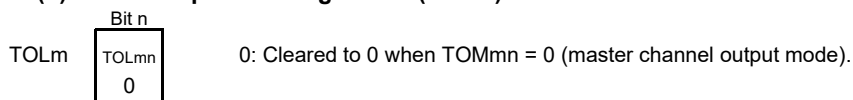

(e) **Timer output mode register m (TOMm)**

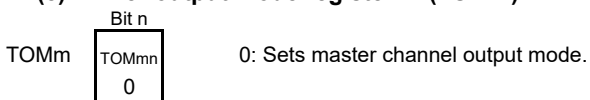

Note TMRm2, TMRm4, TMRm6: MASTERmn = 1
TMRm0: Fixed to 0

Remark m: Unit number (m = 0, 1), n: Channel number (n = 0, 2, 4)

Figure 6-78. Example of Set Contents of Registers
When Multiple PWM Output Function (Slave Channel) Is Used (output two types of PWMs)

(a) Timer mode register mp, mq (TMRmp, TMRmq)

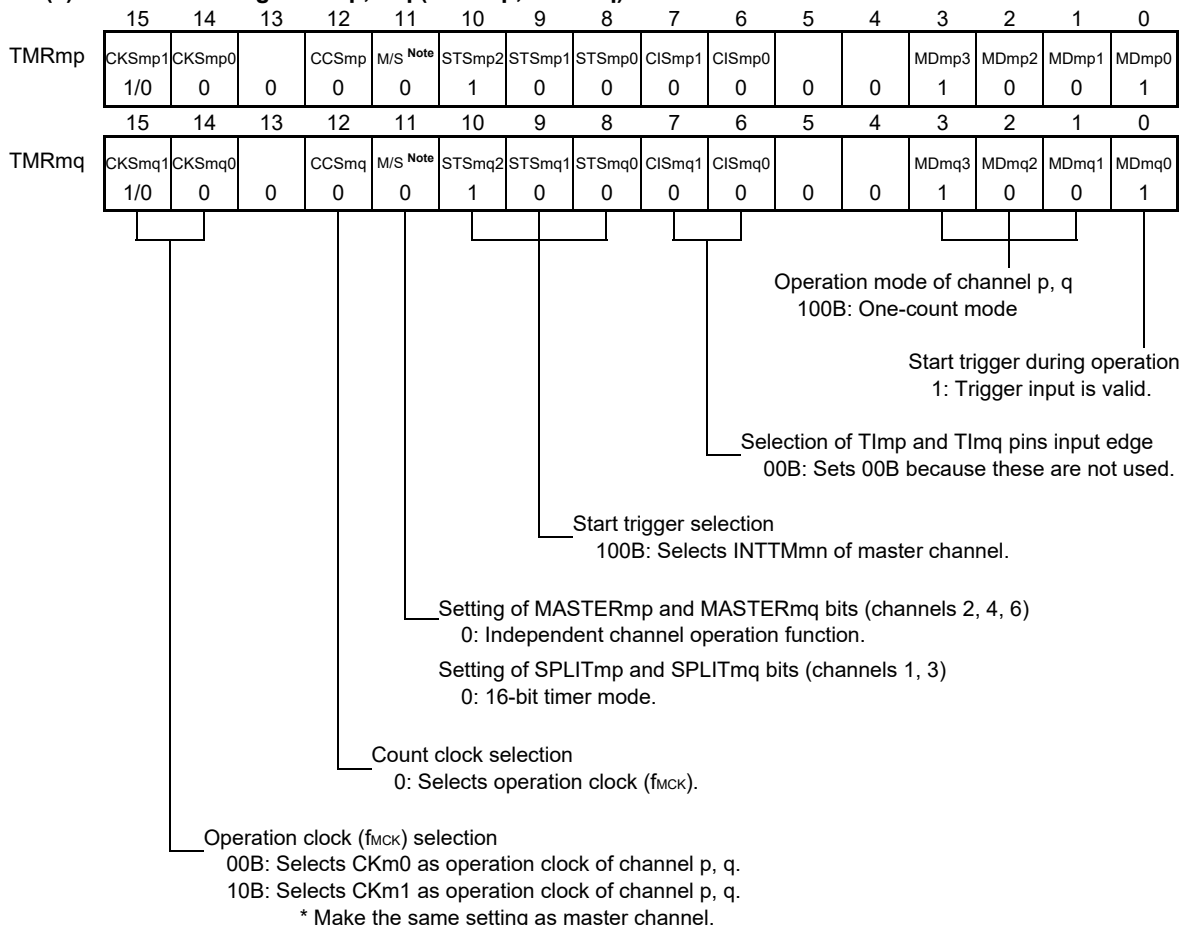

(b) Timer output register m (TOM)

	Bit q	Bit p	
TOM	TOM _q	TOM _p	0: Outputs 0 from TOM _p or TOM _q .
	1/0	1/0	1: Outputs 1 from TOM _p or TOM _q .

(c) Timer output enable register m (TOEm)

	Bit q	Bit p	
TOEm	TOEm _q	TOEm _p	0: Stops the TOM _p or TOM _q output operation by counting operation.
	1/0	1/0	1: Enables the TOM _p or TOM _q output operation by counting operation.

(d) Timer output level register m (TOLm)

	Bit q	Bit p	
TOLm	TOLm _q	TOLm _p	0: Positive logic output (active-high)
	1/0	1/0	1: Negative logic output (active-low)

(e) Timer output mode register m (TOMm)

	Bit q	Bit p	
TOMm	TOMm _q	TOMm _p	1: Sets the slave channel output mode.
	1	1	

Note TMRm2, TMRm4, TMRm6: MASTERmp, MASTERmq bit
 TMRm1, TMRm3: SPLITmp, SPLITmq bit
 TMRm5, TMRm7: Fixed to 0

Remark m: Unit number (m = 0, 1), n: Channel number (n = 0, 2, 4)
 p: Slave channel number 1, q: Slave channel number 2
 n < p < q ≤ 7 (Where p and q are integers greater than n)

Figure 6-79. Operation Procedure When Multiple PWM Output Function Is Used (1/2)

	Software Operation	Hardware Status
TAU default setting		Power-off status (Clock supply is stopped and writing to each register is disabled.)
	Sets the TAUmEN bit of peripheral enable register 0 (PER0) to 1. →	Power-on status. Each channel stops operating. (Clock supply is started and writing to each register is enabled.)
	Sets timer clock select register m (TPSm). Determines clock frequencies of CKm0 and CKm1.	
Channel default setting	Sets timer mode registers mn, mp, 0q (TMRmn, TMRmp, TMRmq) of each channel to be used (determines operation mode of channels). An interval (period) value is set to timer data register mn (TDRmn) of the master channel, and a duty factor is set to the TDRmp and TDRmq registers of the slave channels.	Channel stops operating. (Clock is supplied and some power is consumed.)
	Sets slave channels. The TOMmp and TOMmq bits of timer output mode register m (TOMm) are set to 1 (slave channel output mode). Sets the TOLmp and TOLmq bits. Sets the TOmp and TOMq bits and determines default level of the TOmp and TOMq outputs. →	The TOmp and TOMq pins go into Hi-Z output state. The TOmp and TOMq default setting levels are output when the port mode register is in output mode and the port register is 0.
	Sets the TOEmp and TOEmq bits to 1 and enables operation of TOmp and TOMq. →	TOmp and TOMq do not change because channels stop operating.
	Clears the port register and port mode register to 0. →	The TOmp and TOMq pins output the TOmp and TOMq set levels.

(Remark is listed on the next page.)

Figure 6-79. Operation Procedure When Multiple PWM Output Function Is Used (2/2)

	Software Operation	Hardware Status
Operation is resumed.	<p>Operation start</p> <p>(Sets the TOEmp and TOEmq (slave) bits to 1 only when resuming operation.) The TSmn bit (master), and TSmp and TSmq (slave) bits of timer channel start register m (TSM) are set to 1 at the same time. The TSmn, TSmp, and TSmq bits automatically return to 0 because they are trigger bits.</p>	<p>TEmn = 1, TEmq, TEMq = 1</p> <p>When the master channel starts counting, INTTMmn is generated. Triggered by this interrupt, the slave channel also starts counting.</p>
	<p>During operation</p> <p>Set values of the TMRmn, TMRmp, TMRmq registers, TOMmn, TOMmp, TOMmq, TOLmn, TOLmp, and TOLmq bits cannot be changed. Set values of the TDRmn, TDRmp, and TDRmq registers can be changed after INTTMmn of the master channel is generated. The TCRmn, TCRmp, and TCRmq registers can always be read. The TSRmn, TSRmp, and TSR0q registers are not used.</p>	<p>The counter of the master channel loads the TDRmn register value to timer count register mn (TCRmn) and counts down. When the count value reaches TCRmn = 0000H, INTTMmn output is generated. At the same time, the value of the TDRmn register is loaded to the TCRmn register, and the counter starts counting down again. At the slave channel 1, the values of the TDRmp register are transferred to the TCRmp register, triggered by INTTMmn of the master channel, and the counter starts counting down. The output levels of TOmp become active one count clock after generation of the INTTMmn output from the master channel. It becomes inactive when TCRmp = 0000H, and the counting operation is stopped. At the slave channel 2, the values of the TDRmq register are transferred to TCRmq register, triggered by INTTMmn of the master channel, and the counter starts counting down. The output levels of TOMq become active one count clock after generation of the INTTMmn output from the master channel. It becomes inactive when TCRmq = 0000H, and the counting operation is stopped. After that, the above operation is repeated.</p>
	<p>Operation stop</p> <p>The TTmn bit (master), TTmp, and TTmq (slave) bits are set to 1 at the same time. The TTmn, TTmp, and TTmq bits automatically return to 0 because they are trigger bits.</p>	<p>TEmn, TEmq, TEMq = 0, and count operation stops. The TCRmn, TCRmp, and TCRmq registers hold count value and stop. The TOmp and TOMq output are not initialized but hold current status.</p>
	<p>The TOEmp and TOEmq bits of slave channels are cleared to 0 and value is set to the TOmp and TOMq bits.</p>	<p>The TOmp and TOMq pins output the TOmp and TOMq set levels.</p>
<p>TAU stop</p> <p>To hold the TOmp and TOMq pin output levels Clears the TOmp and TOMq bits to 0 after the value to be held is set to the port register. When holding the TOmp and TOMq pin output levels are not necessary Setting not required</p>	<p>The TOmp and TOMq pin output levels are held by port function.</p>	
<p>The TAUmEN bit of the PER0 register is cleared to 0.</p>	<p>Power-off status All circuits are initialized and SFR of each channel is also initialized. (The TOmp and TOMq bits are cleared to 0 and the TOmp and TOMq pins are set to port mode.)</p>	

Remark m: Unit number (m = 0, 1), n: Channel number (n = 0, 2, 4)
 p: Slave channel number 1, q: Slave channel number 2
 n < p < q ≤ 7 (Where p and q are a consecutive integer greater than n)

6.10 Cautions When Using Timer Array Unit

6.10.1 Cautions When Using Timer Output

Pins may be assigned multiplexed timer output and other alternate functions. The assignment depends on the product. If you intend to use a timer output, set the outputs from all other multiplexed pin functions to their initial values.

For details, see **4.5 Register Settings When Using Alternate Function**.

CHAPTER 7 REAL-TIME CLOCK

7.1 Functions of Real-time Clock

The real-time clock has the following features.

- Having counters of year, month, week, day, hour, minute, and second, and can count up to 99 years.
- Constant-period interrupt function (period: 0.5 seconds, 1 second, 1 minute, 1 hour, 1 day, 1 month)
- Alarm interrupt function (alarm: week, hour, minute)
- Pin output function of 1 Hz (40, 44, 48, 52, 64, 80, 100, and 128-pin products only)

The real-time clock interrupt signal (INTRTC) can be utilized for wakeup from STOP mode and triggering an A/D converter's SNOOZE mode.

Caution The count of year, month, week, day, hour, minutes and second can only be performed when a subsystem clock ($f_{SUB} = 32.768$ kHz) is selected as the operation clock of the real-time clock. When the low-speed oscillation clock ($f_{IL} = 15$ kHz) is selected, only the constant-period interrupt function is available. The 20- to 36-pin products have the constant-period interrupt function only, because these products have no subsystem clock. However, the constant-period interrupt interval when f_{IL} is selected will be calculated with the constant-period (the value selected with RTCC0 register) $\times f_{SUB}/f_{IL}$.

7.2 Configuration of Real-time Clock

The real-time clock includes the following hardware.

Table 7-1. Configuration of Real-time Clock

Item	Configuration
Counter	Internal counter (16-bit)
Control registers	Peripheral enable register 0 (PER0)
	Subsystem clock supply mode control register (OSMC)
	Real-time clock control register 0 (RTCC0)
	Real-time clock control register 1 (RTCC1)
	Second count register (SEC)
	Minute count register (MIN)
	Hour count register (HOUR)
	Day count register (DAY)
	Week count register (WEEK)
	Month count register (MONTH)
	Year count register (YEAR)
	Watch error correction register (SUBCUD)
	Alarm minute register (ALARMWM)
	Alarm hour register (ALARMWH)
Alarm week register (ALARMWW)	

Figure 7-1. Block Diagram of Real-time Clock

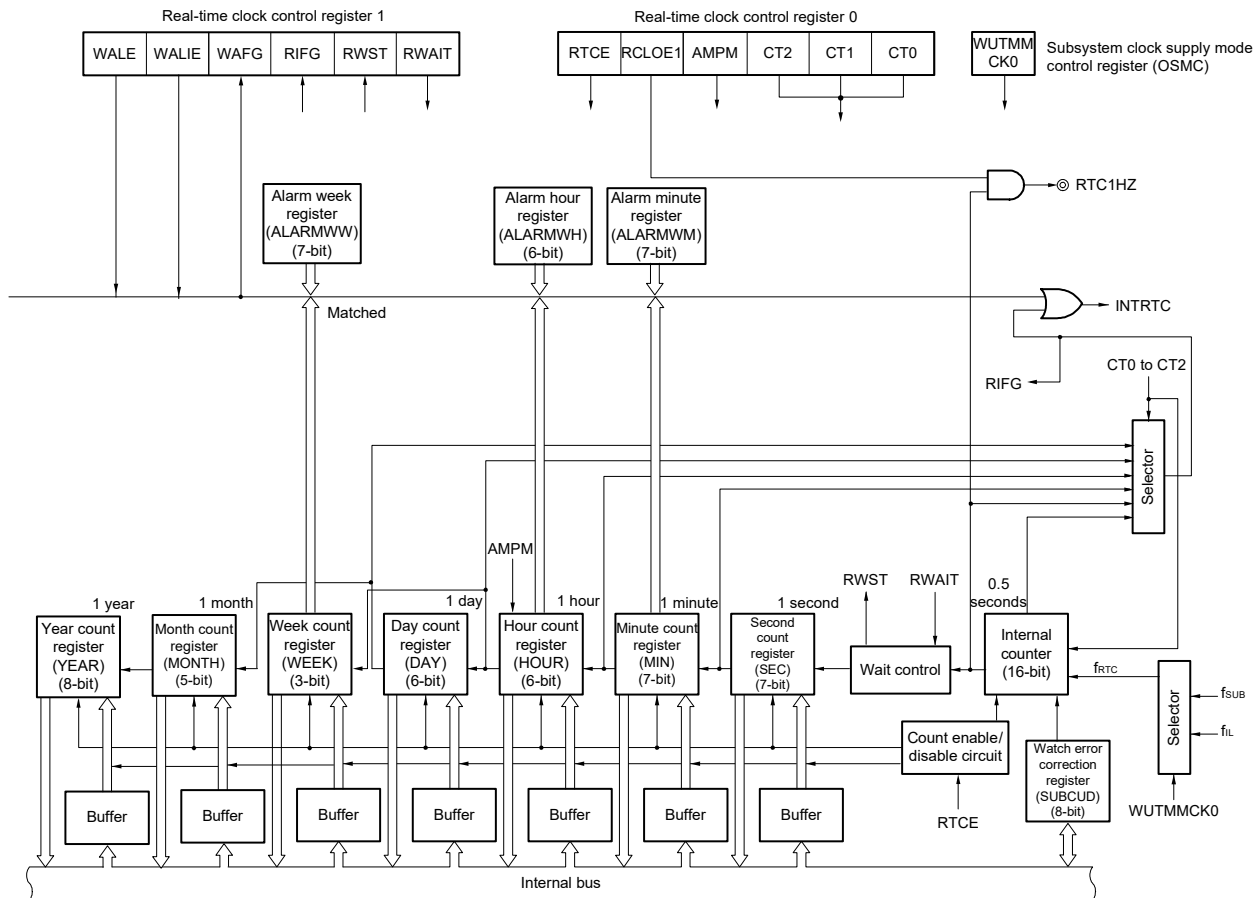

Caution The count of year, month, week, day, hour, minutes and second can only be performed when a subsystem clock ($f_{SUB} = 32.768 \text{ kHz}$) is selected as the operation clock of the real-time clock. When the low-speed oscillation clock ($f_{IL} = 15 \text{ kHz}$) is selected, only the constant-period interrupt function is available. The 20- to 36-pin products have the constant-period interrupt function only, because these products have no subsystem clock. However, the constant-period interrupt interval when f_{IL} is selected will be calculated with the constant-period (the value selected with RTCC0 register) $\times f_{SUB}/f_{IL}$.

7.3 Registers Controlling Real-time Clock

The real-time clock is controlled by the following registers.

- Peripheral enable register 0 (PER0)
- Subsystem clock supply mode control register (OSMC)
- Real-time clock control register 0 (RTCC0)
- Real-time clock control register 1 (RTCC1)
- Second count register (SEC)
- Minute count register (MIN)
- Hour count register (HOUR)
- Day count register (DAY)
- Week count register (WEEK)
- Month count register (MONTH)
- Year count register (YEAR)
- Watch error correction register (SUBCUD)
- Alarm minute register (ALARMWM)
- Alarm hour register (ALARMWH)
- Alarm week register (ALARMWW)
- Port mode register 3 (PM3)
- Port register 3 (P3)

7.3.1 Peripheral enable register 0 (PER0)

This register is used to enable or disable supplying the clock to the peripheral hardware. Clock supply to a hardware macro that is not used is stopped in order to reduce the power consumption and noise.

When the real-time clock is used, be sure to set bit 7 (RTCEN) of this register to 1.

The PER0 register can be set by a 1-bit or 8-bit memory manipulation instruction.

Reset signal generation clears this register to 00H.

Figure 7-2. Format of Peripheral Enable Register 0 (PER0)

Address: F00F0H After reset: 00H R/W

Symbol	<7>	<6>	<5>	<4>	<3>	<2>	<1>	<0>
PER0	RTCEN	IICA1EN Note 1	ADCEN	IICA0EN Note 2	SAU1EN Note 3	SAU0EN	TAU1EN Note 1	TAU0EN

RTCEN	Control of real-time clock (RTC) and 12-bit interval timer input clock supply
0	Stops input clock supply. <ul style="list-style-type: none"> • SFR used by the real-time clock (RTC) and 12-bit interval timer cannot be written. • The real-time clock (RTC) and 12-bit interval timer are in the reset status.
1	Enables input clock supply. <ul style="list-style-type: none"> • SFR used by the real-time clock (RTC) and 12-bit interval timer can be read and written.

- Notes**
- 80, 100, and 128-pin products only.
 - This is not provided in the 20-pin products.
 - This is not provided in the 20, 24, and 25-pin products.

- Cautions**
- When using the real-time clock, first set the RTCEN bit to 1 and then set the following registers, while oscillation of the count clock (f_{RTC}) is stable. If RTCEN = 0, writing to the control registers of the real-time clock is ignored, and, even if the registers are read, only the default values are read (except for the subsystem clock supply mode control register (OSMC), port mode register 3 (PM3), port register 3 (P3)).
 - Real-time clock control register 0 (RTCC0)
 - Real-time clock control register 1 (RTCC1)
 - Second count register (SEC)
 - Minute count register (MIN)
 - Hour count register (HOUR)
 - Day count register (DAY)
 - Week count register (WEEK)
 - Month count register (MONTH)
 - Year count register (YEAR)
 - Watch error correction register (SUBCUD)
 - Alarm minute register (ALARMWMM)
 - Alarm hour register (ALARMWH)
 - Alarm week register (ALARMWW)
 - The subsystem clock supply to peripheral functions other than the real-time clock and 12-bit interval timer can be stopped in STOP mode or HALT mode when the subsystem clock is used, by setting the RTCLPC bit of the subsystem clock supply mode control register (OSMC) to 1. In this case, set the RTCEN bit of the PER0 register to 1 and the other bits (bits 0 to 6) to 0.
 - Be sure to clear the following bits to 0.
 - 20-pin products: bits 1, 3, 4, 6
 - 24, 25-pin products: bits 1, 3, 6
 - 30, 32, 36, 40, 44, 48, 52, 64-pin products: bits 1, 6

7.3.2 Subsystem clock supply mode control register (OSMC)

The WUTMMCK0 bit can be used to select the count clock (f_{RTC}) of the real-time clock.

In addition, by stopping clock functions that are unnecessary, the RTCLPC bit can be used to reduce power consumption. For details about setting the RTCLPC bit, see **CHAPTER 5 CLOCK GENERATOR**.

The OSMC register can be set by an 8-bit memory manipulation instruction.

Reset signal generation clears this register to 00H.

Figure 7-3. Format of Subsystem Clock Supply Mode Control Register (OSMC)

Address: F00F3H After reset: 00H R/W

Symbol	7	6	5	4	3	2	1	0
OSMC	RTCLPC	0	0	WUTMMCK0	0	0	0	0

WUTMMCK0	Selection of operation clock (f_{RTC}) for real-time clock and 12-bit interval timer.
0	Subsystem clock (f_{SUB})
1	Low-speed on-chip oscillator clock (f_{IL})

Caution The count of year, month, week, day, hour, minutes and second can only be performed when a subsystem clock ($f_{SUB} = 32.768$ kHz) is selected as the operation clock of the real-time clock. When the low-speed oscillation clock ($f_{IL} = 15$ kHz) is selected, only the constant-period interrupt function is available. The 20- to 36-pin products have the constant-period interrupt function only, because these products have no subsystem clock. However, the constant-period interrupt interval when f_{IL} is selected will be calculated with the constant-period (the value selected with RTCC0 register) $\times f_{SUB}/f_{IL}$.

7.3.3 Real-time clock control register 0 (RTCC0)

The RTCC0 register is an 8-bit register that is used to start or stop the real-time clock operation, control the RTC1HZ pin, and set a 12- or 24-hour system and the constant-period interrupt function.

The RTCC0 register can be set by a 1-bit or 8-bit memory manipulation instruction.
Reset signal generation clears this register to 00H.

Figure 7-4. Format of Real-time Clock Control Register 0 (RTCC0)

Address: FFF9DH After reset: 00H R/W

Symbol	<7>	6	<5>	4	3	2	1	0
RTCC0	RTCE	0	RCLOE1 ^{Note}	0	AMPM	CT2	CT1	CT0

RTCE	Real-time clock operation control
0	Stops counter operation.
1	Starts counter operation.

RCLOE1	RTC1HZ pin output control
0	Disables output of the RTC1HZ pin (1 Hz).
1	Enables output of the RTC1HZ pin (1 Hz).

AMPM	Selection of 12-/24-hour system
0	12-hour system (a.m. and p.m. are displayed.)
1	24-hour system
<ul style="list-style-type: none"> • Rewrite the AMPM bit value after setting the RWAIT bit (bit 0 of real-time clock control register 1 (RTCC1)) to 1. If the AMPM bit value is changed, the values of the hour count register (HOUR) change according to the specified time system. • Table 7-2 shows the displayed time digits that are displayed. 	

CT2	CT1	CT0	Constant-period interrupt (INTRTC) selection
0	0	0	Does not use constant-period interrupt function.
0	0	1	Once per 0.5 s (synchronized with second count up)
0	1	0	Once per 1 s (same time as second count up)
0	1	1	Once per 1 m (second 00 of every minute)
1	0	0	Once per 1 hour (minute 00 and second 00 of every hour)
1	0	1	Once per 1 day (hour 00, minute 00, and second 00 of every day)
1	1	×	Once per 1 month (Day 1, hour 00 a.m., minute 00, and second 00 of every month)
When changing the values of the CT2 to CT0 bits while the counter operates (RTCE = 1), rewrite the values of the CT2 to CT0 bits after disabling interrupt servicing INTRTC by using the interrupt mask flag register. Furthermore, after rewriting the values of the CT2 to CT0 bits, enable interrupt servicing after clearing the RIFG and RTCIF flags.			

Note Set the RCLOE1 bit to 0 in the 20- to 36-pin products.

- Cautions**
1. Do not change the value of the RCLOE1 bit when RTCE = 1.
 2. 1 Hz is not output even if RCLOE1 1 is set to 1 when RTCE = 0.

Remark ×: don't care

7.3.4 Real-time clock control register 1 (RTCC1)

The RTCC1 register is an 8-bit register that is used to control the alarm interrupt function and the wait time of the counter.

The RTCC1 register can be set by a 1-bit or 8-bit memory manipulation instruction.

Reset signal generation clears this register to 00H.

Figure 7-5. Format of Real-time Clock Control Register 1 (RTCC1) (1/2)

Address: FFF9EH After reset: 00H R/W

Symbol	<7>	<6>	5	<4>	<3>	2	<1>	<0>
RTCC1	WALE	WALIE	0	WAFG	RIFG	0	RWST	RWAIT

WALE	Alarm operation control
0	Match operation is invalid.
1	Match operation is valid.
When setting a value to the WALE bit while the counter operates (RTCE = 1) and WALIE = 1, rewrite the WALE bit after disabling interrupt servicing INTRTC by using the interrupt mask flag register. Furthermore, clear the WAFG and RTCIF flags after rewriting the WALE bit. When setting each alarm register (WALIE flag of real-time clock control register 1 (RTCC1), the alarm minute register (ALARMWM), the alarm hour register (ALARMWH), and the alarm week register (ALARMWW)), set match operation to be invalid ("0") for the WALE bit.	

WALIE	Control of alarm interrupt (INTRTC) function operation
0	Does not generate interrupt on matching of alarm.
1	Generates interrupt on matching of alarm.

WAFG	Alarm detection status flag
0	Alarm mismatch
1	Detection of matching of alarm
This is a status flag that indicates detection of matching with the alarm. It is valid only when WALE = 1 and is set to "1" one cycle of f _{RTC} after matching of the alarm is detected. This flag is cleared when "0" is written to it. Writing "1" to it is invalid.	

Figure 7-5. Format of Real-time Clock Control Register 1 (RTCC1) (2/2)

RIFG	Constant-period interrupt status flag
0	Constant-period interrupt is not generated.
1	Constant-period interrupt is generated.
This flag indicates the status of generation of the constant-period interrupt. When the constant-period interrupt is generated, it is set to "1". This flag is cleared when "0" is written to it. Writing "1" to it is invalid.	

RWST	Wait status flag of real-time clock
0	Counter is operating.
1	Mode to read or write counter value
This status flag indicates whether the setting of the RWAIT bit is valid. Before reading or writing the counter value, confirm that the value of this flag is 1.	

RWAIT	Wait control of real-time clock
0	Sets counter operation.
1	Stops SEC to YEAR counters. Mode to read or write counter value
This bit controls the operation of the counter. Be sure to write "1" to it to read or write the counter value. As the internal counter (16-bit) is continuing to run, complete reading or writing within one second and turn back to 0. When reading or writing to the counter is required while generation of the alarm interrupt is enabled, first set the CT2 to CT0 bits to 010B (generating the constant-period interrupt once per 1 second). Then, complete the processing from setting the RWAIT bit to 1 to setting it to 0 before generation of the next constant-period interrupt. When RWAIT = 1, it takes up to one cycle of f_{RTC} until the counter value can be read or written (RWST = 1). ^{Notes 1, 2} When the internal counter (16-bit) overflowed while RWAIT = 1, it keeps the event of overflow until RWAIT = 0, then counts up. However, when it wrote a value to second count register, it will not keep the overflow event.	

- Notes**
1. When the RWAIT bit is set to 1 within one cycle of f_{RTC} clock after setting the RTCE bit to 1, the RWST bit being set to 1 may take up to two cycles of the operating clock (f_{RTC}).
 2. When the RWAIT bit is set to 1 within one cycle of f_{RTC} clock after release from the standby mode (HALT mode, STOP mode, or SNOOZE mode), the RWST bit being set to 1 may take up to two cycles of the operating clock (f_{RTC}).

Caution If writing is performed to the RTCC1 register with a 1-bit manipulation instruction, the RIFG flag and WAFG flag may be cleared. Therefore, to perform writing to the RTCC1 register, be sure to use an 8-bit manipulation instruction. To prevent the RIFG flag and WAFG flag from being cleared during writing, disable writing by setting 1 to the corresponding bit. If the RIFG flag and WAFG flag are not used and the value may be changed, the RTCC1 register may be written by using a 1-bit manipulation instruction.

- Remarks**
1. Fixed-cycle interrupts and alarm match interrupts use the same interrupt source (INTRTC). When using these two types of interrupts at the same time, which interrupt occurred can be judged by checking the fixed-cycle interrupt status flag (RIFG) and the alarm detection status flag (WAFG) upon INTRTC occurrence.
 2. The internal counter (16 bits) is cleared when the second count register (SEC) is written.

7.3.5 Second count register (SEC)

The SEC register is an 8-bit register that takes a value of 0 to 59 (decimal) and indicates the count value of seconds.

It counts up when the internal counter (16-bit) overflows.

When data is written to this register, it is written to a buffer and then to the counter up to two cycles of f_{RTC} later.

Set a decimal value of 00 to 59 to this register in BCD code.

The SEC register can be set by an 8-bit memory manipulation instruction.

Reset signal generation clears this register to 00H.

Figure 7-6. Format of Second Count Register (SEC)

Address: FFF92H After reset: 00H R/W

Symbol	7	6	5	4	3	2	1	0
SEC	0	SEC40	SEC20	SEC10	SEC8	SEC4	SEC2	SEC1

Caution When it reads or writes from/to the register while the counter is in operation (RTCE = 1), follow the procedures described in 7.4.3 Reading/writing real-time clock.

Remark The internal counter (16 bits) is cleared when the second count register (SEC) is written.

7.3.6 Minute count register (MIN)

The MIN register is an 8-bit register that takes a value of 0 to 59 (decimal) and indicates the count value of minutes.

It counts up when the second counter overflows.

When data is written to this register, it is written to a buffer and then to the counter up to two cycles of f_{RTC} later. Even if the second count register overflows while this register is being written, this register ignores the overflow and is set to the value written. Set a decimal value of 00 to 59 to this register in BCD code.

The MIN register can be set by an 8-bit memory manipulation instruction.

Reset signal generation clears this register to 00H.

Figure 7-7. Format of Minute Count Register (MIN)

Address: FFF93H After reset: 00H R/W

Symbol	7	6	5	4	3	2	1	0
MIN	0	MIN40	MIN20	MIN10	MIN8	MIN4	MIN2	MIN1

Caution When it reads or writes from/to the register while the counter is in operation (RTCE = 1), follow the procedures described in 7.4.3 Reading/writing real-time clock.

7.3.7 Hour count register (HOUR)

The HOUR register is an 8-bit register that takes a value of 00 to 23 or 01 to 12 and 21 to 32 (decimal) and indicates the count value of hours.

It counts up when the minute counter overflows.

When data is written to this register, it is written to a buffer and then to the counter up to two cycles of `FRTC` later. Even if the minute count register overflows while this register is being written, this register ignores the overflow and is set to the value written. Specify a decimal value of 00 to 23, 01 to 12, or 21 to 32 by using BCD code according to the time system specified using bit 3 (AMPM) of real-time clock control register 0 (RTCC0).

If the AMPM bit value is changed, the values of the HOUR register change according to the specified time system.

The HOUR register can be set by an 8-bit memory manipulation instruction.

Reset signal generation clears this register to 12H.

However, the value of this register is 00H if the AMPM bit (bit 3 of the RTCC0 register) is set to 1 after reset.

Figure 7-8. Format of Hour Count Register (HOUR)

Address: FFF94H After reset: 12H R/W

Symbol	7	6	5	4	3	2	1	0
HOUR	0	0	HOUR20	HOUR10	HOUR8	HOUR4	HOUR2	HOUR1

- Cautions**
1. Bit 5 (HOUR20) of the HOUR register indicates AM(0)/PM(1) if AMPM = 0 (if the 12-hour system is selected).
 2. When it reads or writes from/to the register while the counter is in operation (RTCE = 1), follow the procedures described in 7.4.3 Reading/writing real-time clock.

Table 7-2 shows the relationship between the setting value of the AMPM bit, the hour count register (HOUR) value, and time.

Table 7-2. Displayed Time Digits

24-Hour Display (AMPM = 1)		12-Hour Display (AMPM = 0)	
Time	HOUR Register	Time	HOUR Register
0	00H	12 a.m.	12H
1	01H	1 a.m.	01H
2	02H	2 a.m.	02H
3	03H	3 a.m.	03H
4	04H	4 a.m.	04H
5	05H	5 a.m.	05H
6	06H	6 a.m.	06H
7	07H	7 a.m.	07H
8	08H	8 a.m.	08H
9	09H	9 a.m.	09H
10	10H	10 a.m.	10H
11	11H	11 a.m.	11H
12	12H	12 p.m.	32H
13	13H	1 p.m.	21H
14	14H	2 p.m.	22H
15	15H	3 p.m.	23H
16	16H	4 p.m.	24H
17	17H	5 p.m.	25H
18	18H	6 p.m.	26H
19	19H	7 p.m.	27H
20	20H	8 p.m.	28H
21	21H	9 p.m.	29H
22	22H	10 p.m.	30H
23	23H	11 p.m.	31H

The HOUR register value is set to 12-hour display when the AMPM bit is "0" and to 24-hour display when the AMPM bit is "1".

In 12-hour display, the fifth bit of the HOUR register displays 0 for AM and 1 for PM.

7.3.8 Day count register (DAY)

The DAY register is an 8-bit register that takes a value of 1 to 31 (decimal) and indicates the count value of days. It counts up when the hour counter overflows.

This counter counts as follows.

- 01 to 31 (January, March, May, July, August, October, December)
- 01 to 30 (April, June, September, November)
- 01 to 29 (February, leap year)
- 01 to 28 (February, normal year)

When data is written to this register, it is written to a buffer and then to the counter up to two cycles of `FRTC` later. Even if the hour count register overflows while this register is being written, this register ignores the overflow and is set to the value written. Set a decimal value of 01 to 31 to this register in BCD code.

The DAY register can be set by an 8-bit memory manipulation instruction.

Reset signal generation clears this register to 01H.

Figure 7-9. Format of Day Count Register (DAY)

Address: FFF96H After reset: 01H R/W

Symbol	7	6	5	4	3	2	1	0
DAY	0	0	DAY20	DAY10	DAY8	DAY4	DAY2	DAY1

Caution When it reads or writes from/to the register while the counter is in operation (`RTCE = 1`), follow the procedures described in 7.4.3 Reading/writing real-time clock.

7.3.9 Week count register (WEEK)

The WEEK register is an 8-bit register that takes a value of 0 to 6 (decimal) and indicates the count value of weekdays. It counts up in synchronization with the day counter.

When data is written to this register, it is written to a buffer and then to the counter up to two cycles of `FRTC` later. Set a decimal value of 00 to 06 to this register in BCD code.

The WEEK register can be set by an 8-bit memory manipulation instruction.

Reset signal generation clears this register to 00H.

Figure 7-10. Format of Week Count Register (WEEK)

Address: FFF95H After reset: 00H R/W

Symbol	7	6	5	4	3	2	1	0
WEEK	0	0	0	0	0	WEEK4	WEEK2	WEEK1

- Cautions**
1. The value corresponding to the month count register (MONTH) or the day count register (DAY) is not stored in the week count register (WEEK) automatically. After reset release, set the week count register as follow.

Day	WEEK
Sunday	00H
Monday	01H
Tuesday	02H
Wednesday	03H
Thursday	04H
Friday	05H
Saturday	06H

2. When it reads or writes from/to the register while the counter is in operation (`RTCE = 1`), follow the procedures described in 7.4.3 Reading/writing real-time clock.

7.3.10 Month count register (MONTH)

The MONTH register is an 8-bit register that takes a value of 1 to 12 (decimal) and indicates the count value of months. It counts up when the day counter overflows.

When data is written to this register, it is written to a buffer and then to the counter up to two cycles of `FRTC` later. Even if the day count register overflows while this register is being written, this register ignores the overflow and is set to the value written. Set a decimal value of 01 to 12 to this register in BCD code.

The MONTH register can be set by an 8-bit memory manipulation instruction. Reset signal generation clears this register to 01H.

Figure 7-11. Format of Month Count Register (MONTH)

Address: FFF97H After reset: 01H R/W

Symbol	7	6	5	4	3	2	1	0
MONTH	0	0	0	MONTH10	MONTH8	MONTH4	MONTH2	MONTH1

Caution When it reads or writes from/to the register while the counter is in operation (`RTCE = 1`), follow the procedures described in 7.4.3 Reading/writing real-time clock.

7.3.11 Year count register (YEAR)

The YEAR register is an 8-bit register that takes a value of 0 to 99 (decimal) and indicates the count value of years. It counts up when the month count register (MONTH) overflows.

Values 00, 04, 08, ..., 92, and 96 indicate a leap year.

When data is written to this register, it is written to a buffer and then to the counter up to two cycles of `FRTC` later. Even if the MONTH register overflows while this register is being written, this register ignores the overflow and is set to the value written. Set a decimal value of 00 to 99 to this register in BCD code.

The YEAR register can be set by an 8-bit memory manipulation instruction. Reset signal generation clears this register to 00H.

Figure 7-12. Format of Year Count Register (YEAR)

Address: FFF98H After reset: 00H R/W

Symbol	7	6	5	4	3	2	1	0
YEAR	YEAR80	YEAR40	YEAR20	YEAR10	YEAR8	YEAR4	YEAR2	YEAR1

Caution When it reads or writes from/to the register while the counter is in operation (`RTCE = 1`), follow the procedures described in 7.4.3 Reading/writing real-time clock.

7.3.12 Watch error correction register (SUBCUD)

This register is used to correct the watch with high accuracy when it is slow or fast by changing the value that overflows from the internal counter (16-bit) to the second count register (SEC) (reference value: 7FFFH).

The SUBCUD register can be set by an 8-bit memory manipulation instruction.

Reset signal generation clears this register to 00H.

Figure 7-13. Format of Watch Error Correction Register (SUBCUD)

Address: FFF99H After reset: 00H R/W

Symbol	7	6	5	4	3	2	1	0
SUBCUD	DEV	F6	F5	F4	F3	F2	F1	F0

DEV	Setting of watch error correction timing
0	Corrects watch error when the second digits are at 00, 20, or 40 (every 20 seconds).
1	Corrects watch error only when the second digits are at 00 (every 60 seconds).
Writing to the SUBCUD register at the following timing is prohibited.	
<ul style="list-style-type: none"> • When DEV = 0 is set: For a period of SEC = 00H, 20H, 40H • When DEV = 1 is set: For a period of SEC = 00H 	

F6	Setting of watch error correction value
0	Increases by $\{(F5, F4, F3, F2, F1, F0) - 1\} \times 2$.
1	Decreases by $\{(/F5, /F4, /F3, /F2, /F1, /F0) + 1\} \times 2$.
When (F6, F5, F4, F3, F2, F1, F0) = (*, 0, 0, 0, 0, 0, *), the watch error is not corrected. * is 0 or 1. /F5 to /F0 are the inverted values of the corresponding bits (000011 when 111100).	
Range of correction value: (when F6 = 0) 2, 4, 6, 8, ..., 120, 122, 124 (when F6 = 1) -2, -4, -6, -8, ..., -120, -122, -124	

The range of value that can be corrected by using the watch error correction register (SUBCUD) is shown below.

	DEV = 0 (correction every 20 seconds)	DEV = 1 (correction every 60 seconds)
Correctable range	-189.2 ppm to 189.2 ppm	-63.1 ppm to 63.1 ppm
Maximum excludes quantization error	±1.53 ppm	±0.51 ppm
Minimum resolution	±3.05 ppm	±1.02 ppm

Remark If a correctable range is -63.1 ppm or lower and 63.1 ppm or higher, set 0 to DEV.

7.3.13 Alarm minute register (ALARMWWM)

This register is used to set minutes of alarm.

The ALARMWWM register can be set by an 8-bit memory manipulation instruction.

Reset signal generation clears this register to 00H.

Caution Set a decimal value of 00 to 59 to this register in BCD code. If a value outside the range is set, the alarm is not detected.

Figure 7-14. Format of Alarm Minute Register (ALARMWWM)

Address: FFF9AH After reset: 00H R/W

Symbol	7	6	5	4	3	2	1	0
ALARMWWM	0	WM40	WM20	WM10	WM8	WM4	WM2	WM1

7.3.14 Alarm hour register (ALARMWH)

This register is used to set hours of alarm.

The ALARMWH register can be set by an 8-bit memory manipulation instruction.

Reset signal generation clears this register to 12H.

However, the value of this register is 00H if the AMPM bit (bit 3 of the RTCC0 register) is set to 1 after reset.

Caution Set a decimal value of 00 to 23, 01 to 12, or 21 to 32 to this register in BCD code. If a value outside the range is set, the alarm is not detected.

Figure 7-15. Format of Alarm Hour Register (ALARMWH)

Address: FFF9BH After reset: 12H R/W

Symbol	7	6	5	4	3	2	1	0
ALARMWH	0	0	WH20	WH10	WH8	WH4	WH2	WH1

Caution Bit 5 (WH20) of the ALARMWH register indicates AM(0)/PM(1) if AMPM = 0 (if the 12-hour system is selected).

7.3.15 Alarm week register (ALARMWW)

This register is used to set date of alarm.

The ALARMWW register can be set by an 8-bit memory manipulation instruction.

Reset signal generation clears this register to 00H.

Figure 7-16. Format of Alarm Week Register (ALARMWW)

Address: FFF9CH After reset: 00H R/W

Symbol	7	6	5	4	3	2	1	0
ALARMWW	0	WW6	WW5	WW4	WW3	WW2	WW1	WW0

Here is an example of setting the alarm.

Time of Alarm	Day							12-Hour Display				24-Hour Display			
	Sunday	Monday	Tuesday	Wednesday	Thursday	Friday	Saturday	Hour 10	Hour 1	Minute 10	Minute 1	Hour 10	Hour 1	Minute 10	Minute 1
	W W 0	W W 1	W W 2	W W 3	W W 4	W W 5	W W 6								
Every day, 0:00 a.m.	1	1	1	1	1	1	1	1	2	0	0	0	0	0	0
Every day, 1:30 a.m.	1	1	1	1	1	1	1	0	1	3	0	0	1	3	0
Every day, 11:59 a.m.	1	1	1	1	1	1	1	1	1	5	9	1	1	5	9
Monday through Friday, 0:00 p.m.	0	1	1	1	1	1	0	3	2	0	0	1	2	0	0
Sunday, 1:30 p.m.	1	0	0	0	0	0	0	2	1	3	0	1	3	3	0
Monday, Wednesday, Friday, 11:59 p.m.	0	1	0	1	0	1	0	3	1	5	9	2	3	5	9

7.3.16 Port mode register 3 (PM3)

The PM3 register can be set by a 1-bit or 8-bit manipulation instruction.

Reset signal generation sets this register to FFH.

When using the port 3 as the RTC1HZ pin for output of 1 Hz, set the PM30 bit to 0.

Figure 7-17. Format of Port Mode Register 3 (PM3)

Address: FFF23H After reset: FFH R/W

Symbol	7	6	5	4	3	2	1	0
PM3	1	1	1	1	1	1	PM31	PM30

7.3.17 Port register 3 (P3)

The PM3 register can be set by a 1-bit or 8-bit manipulation instruction.

Reset signal generation sets this register to 00H.

When using the port 3 as 1-Hz output to the RTC1Hz pin, set the P30 bit to 0.

Figure 7-18. Format of Port Register 3 (P3)

Address: FFF03H After reset: 00H R/W

Symbol	7	6	5	4	3	2	1	0
P3	P37	P36	P35	P34	P33	P32	P31	P30

7.4 Real-time Clock Operation

7.4.1 Starting operation of real-time clock

Figure 7-19. Procedure for Starting Operation of Real-time Clock

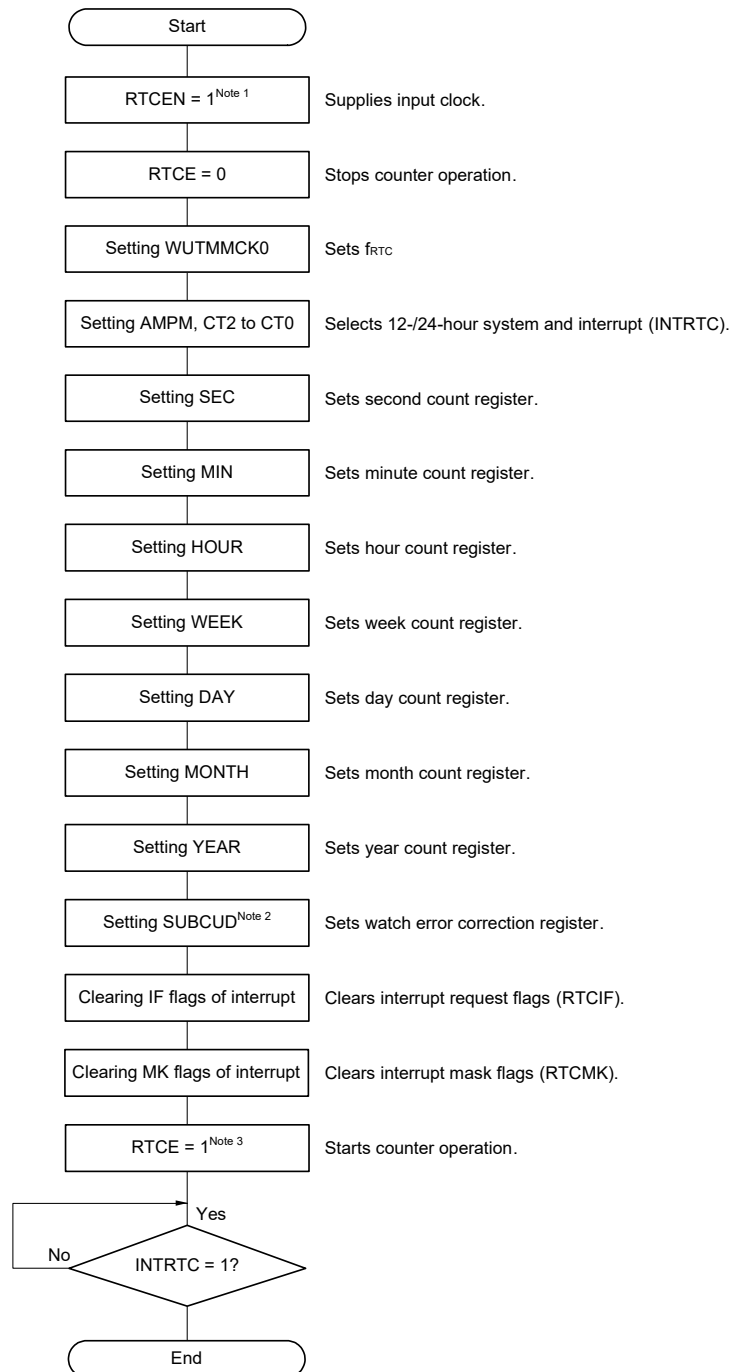

- Notes**
1. First set the RTCEN bit to 1, while oscillation of the count clock (f_{RTC}) is stable.
 2. Set up the SUBCUD register only if the watch error must be corrected. For details about how to calculate the correction value, see **7.4.6 Example of watch error correction of real-time clock**.
 3. Confirm the procedure described in **7.4.2 Shifting to HALT/STOP mode after starting operation** when shifting to HALT/STOP mode without waiting for INTRTC = 1 after RTCE = 1.

7.4.2 Shifting to HALT/STOP mode after starting operation

Perform one of the following processing when shifting to HALT/STOP mode immediately after setting the RTCE bit to 1. However, after setting the RTCE bit to 1, this processing is not required when shifting to HALT/STOP mode after the INTRTC interrupt has occurred.

- Shifting to HALT/STOP mode when at least two cycles of the count clock (f_{RTC}) have elapsed after setting the RTCE bit to 1 (see **Figure 7-20, Example 1**).
- Checking by polling the RWST bit to become 1, after setting the RTCE bit to 1 and then setting the RWAIT bit to 1. Afterward, setting the RWAIT bit to 0 and shifting to HALT/STOP mode after checking again by polling that the RWST bit has become 0 (see **Figure 7-20, Example 2**).

Figure 7-20. Procedure for Shifting to HALT/STOP Mode After Setting RTCE bit to 1

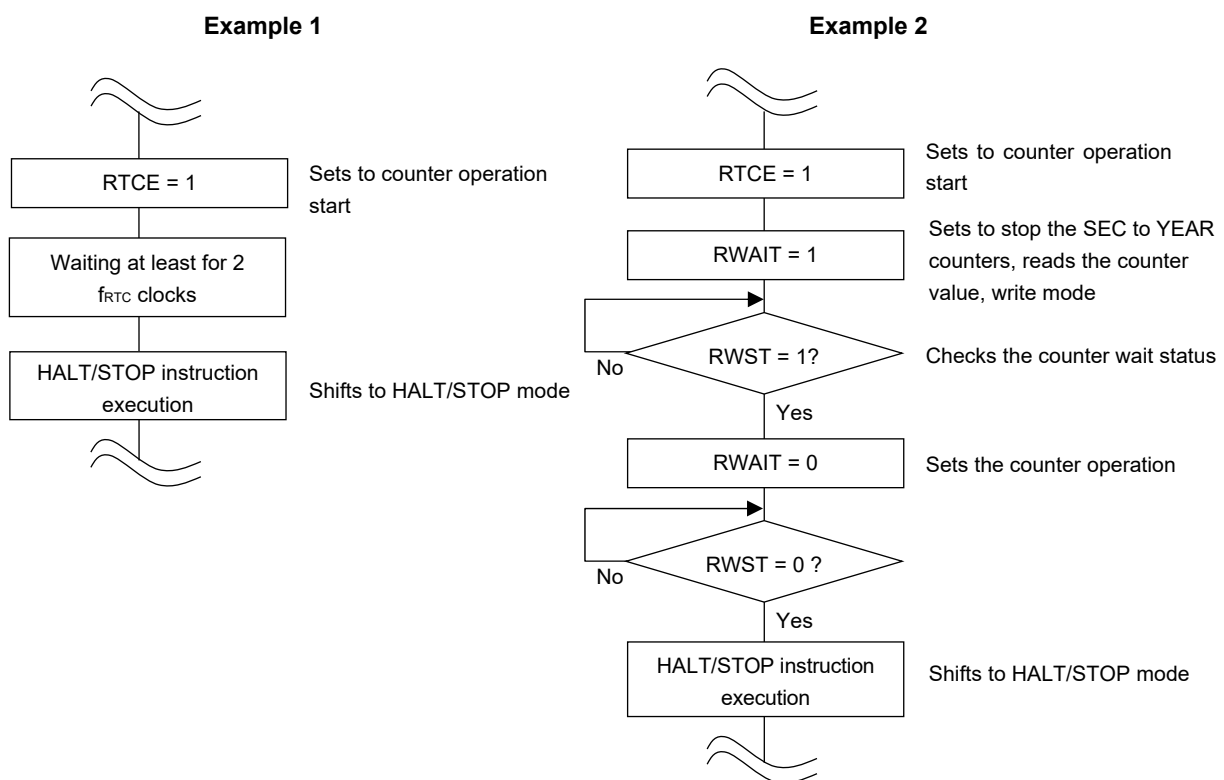

7.4.3 Reading/writing real-time clock

Read or write the counter after setting 1 to RWAIT first.

Set RWAIT to 0 after completion of reading or writing the counter.

Figure 7-21. Procedure for Reading Real-time Clock

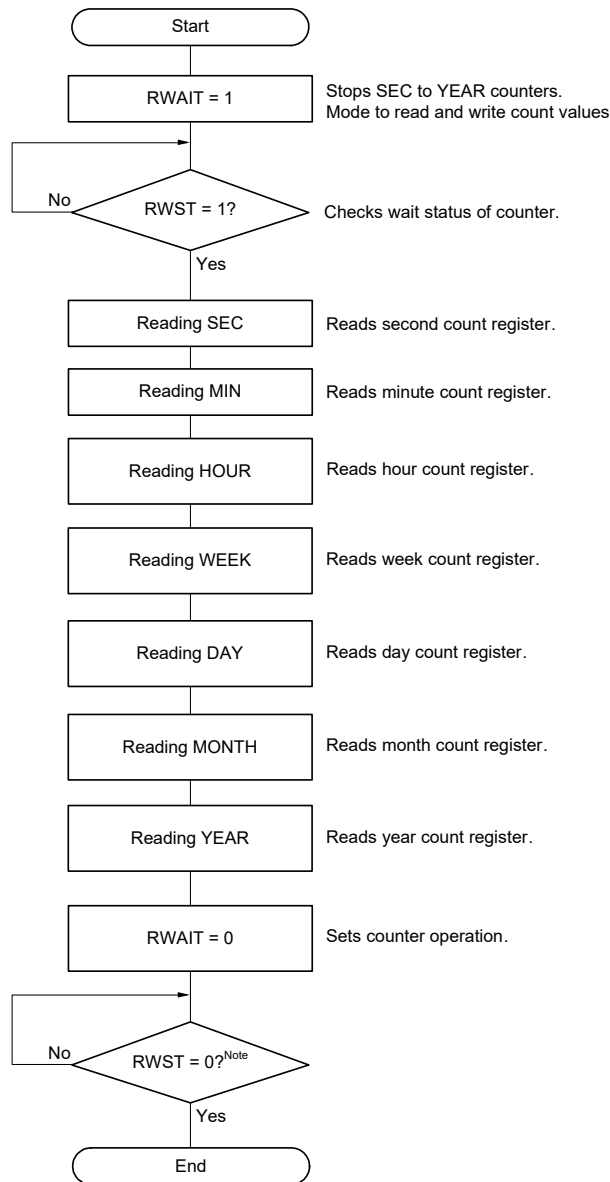

Note Be sure to confirm that RWST = 0 before setting STOP mode.

Caution Complete the series of process of setting the RWAIT bit to 1 to clearing the RWAIT bit to 0 within 1 second. When reading to the counter is required while generation of the alarm interrupt is enabled, first set the CT2 to CT0 bits to 010B (generating the constant-period interrupt once per 1 second). Then, complete the processing from setting the RWAIT bit to 1 to setting it to 0 before generation of the next constant-period interrupt.

Remark The second count register (SEC), minute count register (MIN), hour count register (HOUR), week count register (WEEK), day count register (DAY), month count register (MONTH), and year count register (YEAR) may be read in any sequence.

All the registers do not have to read and only some registers may be read.

Figure 7-22. Procedure for Writing Real-time Clock

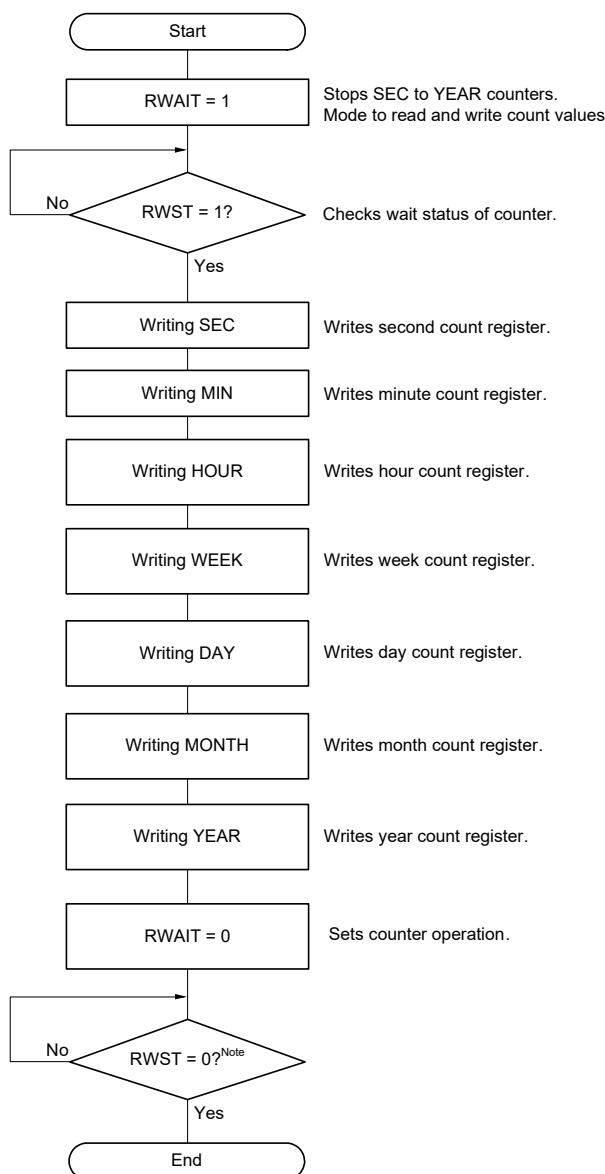

Note Be sure to confirm that RWST = 0 before setting STOP mode.

- Cautions**
1. Complete the series of operations of setting the RWAIT bit to 1 to clearing the RWAIT bit to 0 within 1 second. When writing to the counter is required while generation of the alarm interrupt is enabled, first set the CT2 to CT0 bits to 010B (generating the constant-period interrupt once per 1 second). Then, complete the processing from setting the RWAIT bit to 1 to setting it to 0 before generation of the next constant-period interrupt.
 2. When changing the values of the SEC, MIN, HOUR, WEEK, DAY, MONTH, and YEAR register while the counter operates (RTCE = 1), rewrite the values of the MIN register after disabling interrupt servicing INTRTC by using the interrupt mask flag register. Furthermore, clear the WAFG, RIFG and RTCIF flags after rewriting the MIN register.

Remark The second count register (SEC), minute count register (MIN), hour count register (HOUR), week count register (WEEK), day count register (DAY), month count register (MONTH), and year count register (YEAR) may be written in any sequence.

All the registers do not have to be set and only some registers may be written.

7.4.4 Setting alarm of real-time clock

Set time of alarm after setting 0 to WALE (alarm operation invalid.) first.

Figure 7-23. Alarm processing Procedure

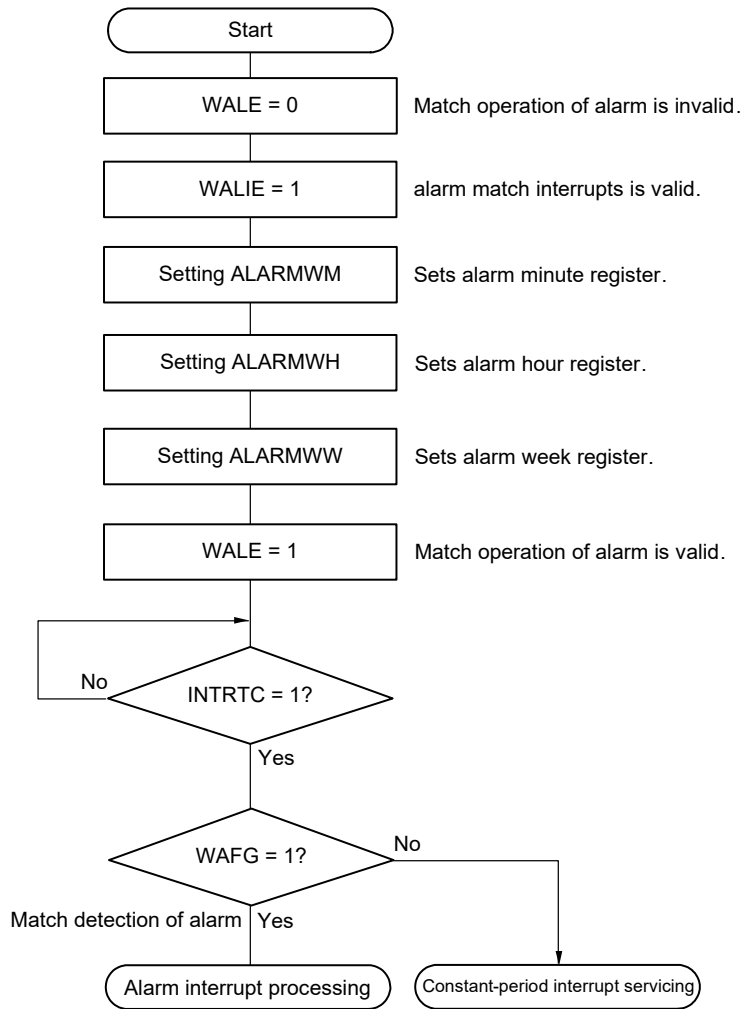

- Remarks 1.** The alarm week register (ALARMWW), alarm hour register (ALARMWH), and alarm week register (ALARMWW) may be written in any sequence.
- 2.** Fixed-cycle interrupts and alarm match interrupts use the same interrupt source (INTRTC). When using these two types of interrupts at the same time, which interrupt occurred can be judged by checking the fixed-cycle interrupt status flag (RIFG) and the alarm detection status flag (WAFG) upon INTRTC occurrence.

7.4.5 1 Hz output of real-time clock

Figure 7-24. 1 Hz Output Setting Procedure

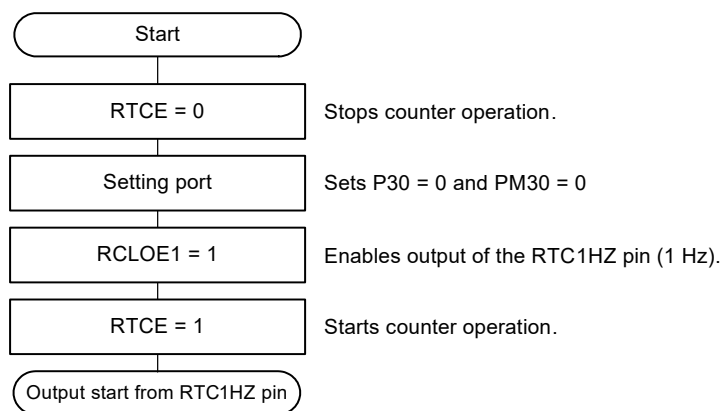

- Cautions**
1. First set the RTCEN bit to 1, while oscillation of the count clock (f_{SUB}) is stable.
 2. Pin output function of 1 Hz is not available in the 20- to 30-pin products.

7.4.6 Example of watch error correction of real-time clock

The watch can be corrected with high accuracy when it is slow or fast, by setting a value to the watch error correction register.

Example of calculating the correction value

The correction value used when correcting the count value of the internal counter (16-bit) is calculated by using the following expression.

Set the DEV bit to 0 when the correction range is -63.1 ppm or less, or 63.1 ppm or more.

(When DEV = 0)

$$\text{Correction value}^{\text{Note}} = \text{Number of correction counts in 1 minute} \div 3 = (\text{Oscillation frequency} \div \text{Target frequency} - 1) \times 32768 \times 60 \div 3$$

(When DEV = 1)

$$\text{Correction value}^{\text{Note}} = \text{Number of correction counts in 1 minute} = (\text{Oscillation frequency} \div \text{Target frequency} - 1) \times 32768 \times 60$$

Note The correction value is the watch error correction value calculated by using bits 6 to 0 of the watch error correction register (SUBCUD).

$$\text{(When F6 = 0) Correction value} = \{(F5, F4, F3, F2, F1, F0) - 1\} \times 2$$

$$\text{(When F6 = 1) Correction value} = -\{(/F5, /F4, /F3, /F2, /F1, /F0) + 1\} \times 2$$

When (F6, F5, F4, F3, F2, F1, F0) is (*, 0, 0, 0, 0, 0, *), watch error correction is not performed. "*" is 0 or 1. /F5 to /F0 are bit-inverted values (000011 when 111100).

- Remarks**
1. The correction value is 2, 4, 6, 8, ... 120, 122, 124 or $-2, -4, -6, -8, \dots -120, -122, -124$.
 2. The oscillation frequency is a value of the count clock (f_{RTC}).
It can be calculated from the output frequency of the RTC1HZ pin $\times 32768$ when the watch error correction register is set to its initial value (00H).
 3. The target frequency is the frequency resulting after correction performed by using the watch error correction register.

Correction example 1

Example of correcting from 32772.3 Hz to 32768 Hz (32772.3 Hz – 131.2 ppm)

[Measuring the oscillation frequency]

The oscillation frequency^{Note} of each product is measured by outputting about 32.768 kHz from the PCLBUZ0 pin, or by outputting about 1 Hz from the RTC1HZ pin when the watch error correction register (SUBCUD) is set to its initial value (00H).

Note See **7.4.5 1 Hz output of real-time clock** for the setting procedure of the RTC1Hz output, and see **9.4 Operations of Clock Output/Buzzer Output Controller** for the setting procedure of outputting about 32 kHz from the PCLBUZ0 pin.

[Calculating the correction value]

(When the output frequency from the PCLBUZ0 pin is 32772.3 Hz)

Assume the target frequency to be 32768 Hz (32772.3 Hz–131.2 ppm) and DEV to be 0, because the correctable range of –131.2 ppm is –63.1 ppm or lower.

The expression for calculating the correction value when DEV is 0 is applied.

$$\begin{aligned} \text{Correction value} &= \text{Number of correction counts in 1 minute} \div 3 \\ &= (\text{Oscillation frequency} \div \text{target frequency} - 1) \times 32768 \times 60 \div 3 \\ &= (32772.3 \div 32768 - 1) \times 32768 \times 60 \div 3 \\ &= 86 \end{aligned}$$

[Calculating the values to be set to (F6 to F0)]

(When the correction value is 86)

If the correction value is 0 or larger (when slowing), assume F6 to be 0.

Calculate (F5, F4, F3, F2, F1, F0) from the correction value.

$$\begin{aligned} \{ (F5, F4, F3, F2, F1, F0) - 1 \} \times 2 &= 86 \\ (F5, F4, F3, F2, F1, F0) &= 44 \\ (F5, F4, F3, F2, F1, F0) &= (1, 0, 1, 1, 0, 0) \end{aligned}$$

Consequently, when correcting from 32772.3 Hz to 32768 Hz (32772.3 Hz – 131.2 ppm), setting the correction register such that DEV is 0 and the correction value is 86 (bits 6 to 0 of the SUBCUD register: 0101100) results in 32768 Hz (0 ppm).

Figure 7-25 shows the operation when (DEV, F6, F5, F4, F3, F2, F1, F0) is (0, 0, 1, 0, 1, 1, 0, 0).

Figure 7-25. Correction Operation when (DEV, F6, F5, F4, F3, F2, F1, F0) = (0, 0, 1, 0, 1, 1, 0, 0)

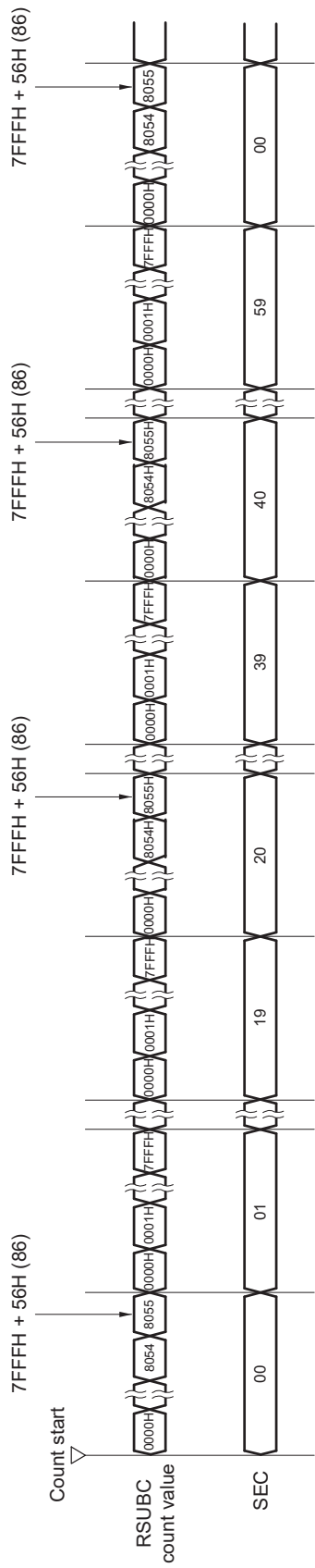

Correction example 2

Example of correcting from 32767.4 Hz to 32768 Hz (32767.4 Hz + 18.3 ppm)

[Measuring the oscillation frequency]

The oscillation frequency^{Note} of each product is measured by outputting about 1 Hz from the RTC1HZ pin when the watch error correction register (SUBCUD) is set to its initial value (00H).

Note See 7.4.5 1 Hz output of real-time clock for the setting procedure of outputting about 1 Hz from the RTC1HZ pin.

[Calculating the correction value]

(When the output frequency from the RTCCL pin is 0.9999817 Hz)

Oscillation frequency = $32768 \times 0.9999817 \approx 32767.4$ Hz

Assume the target frequency to be 32768 Hz (32767.4 Hz + 18.3 ppm) and DEV to be 1.

The expression for calculating the correction value when DEV is 1 is applied.

$$\begin{aligned} \text{Correction value} &= \text{Number of correction counts in 1 minute} \\ &= (\text{Oscillation frequency} \div \text{Target frequency} - 1) \times 32768 \times 60 \\ &= (32767.4 \div 32768 - 1) \times 32768 \times 60 \\ &= -36 \end{aligned}$$

[Calculating the values to be set to (F6 to F0)]

(When the correction value is -36)

If the correction value is 0 or less (when quickening), assume F6 to be 1.

Calculate (F5, F4, F3, F2, F1, F0) from the correction value.

$$\begin{aligned} -\{(/F5, /F4, /F3, /F2, /F1, /F0) - 1\} \times 2 &= -36 \\ (/F5, /F4, /F3, /F2, /F1, /F0) &= 17 \\ (/F5, /F4, /F3, /F2, /F1, /F0) &= (0, 1, 0, 0, 0, 1) \\ (F5, F4, F3, F2, F1, F0) &= (1, 0, 1, 1, 1, 0) \end{aligned}$$

Consequently, when correcting from 32767.4 Hz to 32768 Hz (32767.4 Hz + 18.3 ppm), setting the correction register such that DEV is 1 and the correction value is -36 (bits 6 to 0 of the SUBCUD register: 1101110) results in 32768 Hz (0 ppm).

Figure 7-26 shows the operation when (DEV, F6, F5, F4, F3, F2, F1, F0) is (1, 1, 1, 0, 1, 1, 1, 0).

Figure 7-26. Correction Operation when (DEV, F6, F5, F4, F3, F2, F1, F0) = (1, 1, 1, 0, 1, 1, 1, 0)

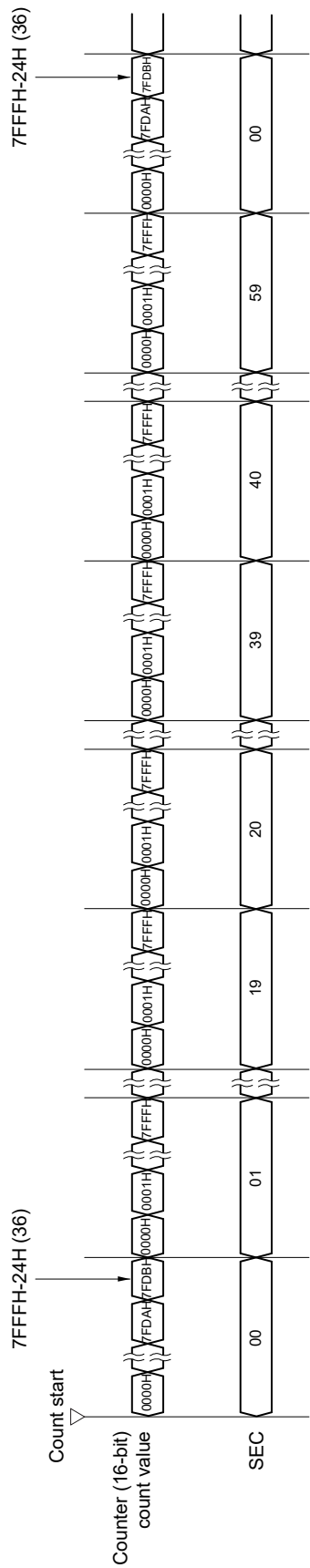

CHAPTER 8 12-BIT INTERVAL TIMER

8.1 Functions of 12-bit Interval Timer

An interrupt (INTIT) is generated at any previously specified time interval. It can be utilized for wakeup from STOP mode and triggering an A/D converter’s SNOOZE mode.

8.2 Configuration of 12-bit Interval Timer

The 12-bit interval timer includes the following hardware.

Table 8-1. Configuration of 12-bit Interval Timer

Item	Configuration
Counter	12-bit counter
Control registers	Peripheral enable register 0 (PER0)
	Subsystem clock supply mode control register (OSMC)
	Interval timer control register (ITMC)

Figure 8-1. Block Diagram of 12-bit Interval Timer

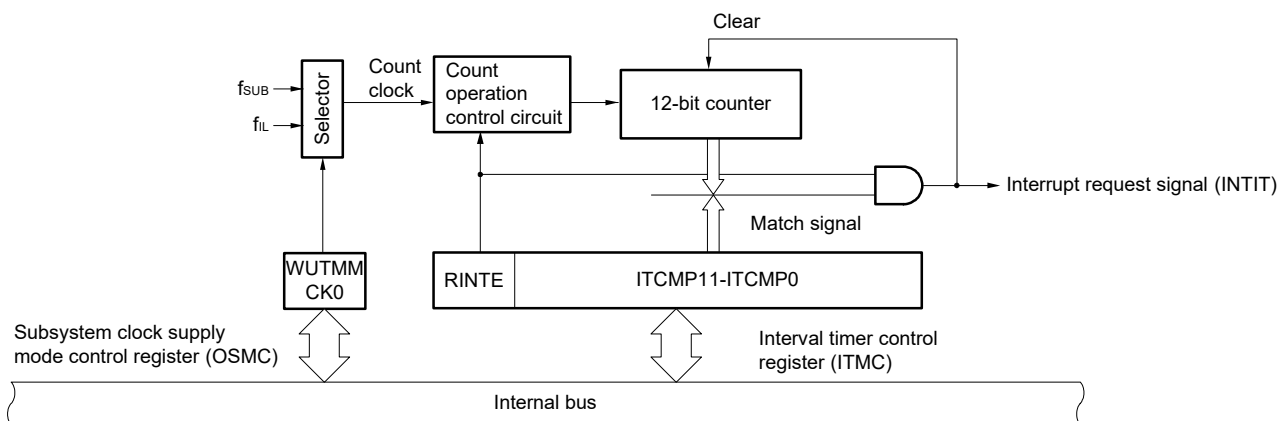

Caution The subsystem clock (f_{SUB}) is selectable as a count clock in the 40- to 128-pin products.

8.3 Registers Controlling 12-bit Interval Timer

The 12-bit interval timer is controlled by the following registers.

- Peripheral enable register 0 (PER0)
- Subsystem clock supply mode control register (OSMC)
- Interval timer control register (ITMC)

8.3.1 Peripheral enable register 0 (PER0)

This register is used to enable or disable supplying the clock to the peripheral hardware. Clock supply to a hardware macro that is not used is stopped in order to reduce the power consumption and noise.

When the 12-bit interval timer is used, be sure to set bit 7 (RTCEN) of this register to 1.

The PER0 register can be set by a 1-bit or 8-bit memory manipulation instruction.

Reset signal generation clears this register to 00H.

Figure 8-2. Format of Peripheral Enable Register 0 (PER0)

Address: F00F0H After reset: 00H R/W

Symbol	<7>	<6>	<5>	<4>	<3>	<2>	<1>	<0>
PER0	RTCEN	IICA1EN Note 1	ADCEN	IICA0EN Note 2	SAU1EN Note 3	SAU0EN	TAU1EN Note 1	TAU0EN

RTCEN	Control of real-time clock (RTC) and 12-bit interval timer input clock supply
0	Stops input clock supply. <ul style="list-style-type: none"> • SFR used by the real-time clock (RTC) and 12-bit interval timer cannot be written. • The real-time clock (RTC) and 12-bit interval timer are in the reset status.
1	Enables input clock supply. <ul style="list-style-type: none"> • SFR used by the real-time clock (RTC) and 12-bit interval timer can be read and written.

- Notes**
1. 80, 100, and 128-pin products only.
 2. This is not provided in the 20-pin products.
 3. This is not provided in the 20, 24, and 25-pin products.

- Cautions**
1. When using the 12-bit interval timer, be sure to first set the RTCEN bit to 1 and then set the interval timer control register (ITMC), while oscillation of the count clock is stable. If RTCEN = 0, writing to the registers controlling the 12-bit interval timer is ignored, and, even if the register is read, only the default value is read (except the subsystem clock supply mode control register (OSMC)).
 2. Clock supply to peripheral functions other than the real-time clock and 12-bit interval timer can be stopped in STOP mode or HALT mode when the subsystem clock is used, by setting the RTCLPC bit of the subsystem clock supply mode control register (OSMC) to 1.
 3. Be sure to clear the following bits to 0.
 - 20-pin products: bits 1, 3, 4, 6
 - 24, 25-pin products: bits 1, 3, 6
 - 30, 32, 36, 40, 44, 48, 52, 64-pin products: bits 1, 6

8.3.2 Subsystem clock supply mode control register (OSMC)

The WUTMMCK0 bit can be used to select the 12-bit interval timer operation clock.

In addition, by stopping clock functions that are unnecessary, the RTCLPC bit can be used to reduce power consumption. For details about setting the RTCLPC bit, see **CHAPTER 5 CLOCK GENERATOR**.

The OSMC register can be set by an 8-bit memory manipulation instruction.

Reset signal generation clears this register to 00H.

Figure 8-3. Format of Subsystem Clock Supply Mode Control Register (OSMC)

Address: F00F3H After reset: 00H R/W

Symbol	7	6	5	4	3	2	1	0
OSMC	RTCLPC	0	0	WUTMMCK0	0	0	0	0

WUTMMCK0	Selection of operation clock for real-time clock and 12-bit interval timer.
0	Subsystem clock (f_{SUB})
1	Low-speed on-chip oscillator clock (f_{IL})

8.3.3 Interval timer control register (ITMC)

This register is used to set up the starting and stopping of the 12-bit interval timer operation and to specify the timer compare value.

The ITMC register can be set by a 16-bit memory manipulation instruction.
Reset signal generation clears this register to 0FFFH.

Figure 8-4. Format of Interval Timer Control Register (ITMC)

Address: FFF90H After reset: 0FFFH R/W

Symbol	15	14	13	12	11 to 0
ITMC	RINTE	0	0	0	ITCMP11 to ITCMP0

RINTE	12-bit Interval timer operation control
0	Count operation stopped (count clear)
1	Count operation started

ITCMP11 to ITCMP0	Specification of the 12-bit interval timer compare value
001H	These bits generate an interrupt at the fixed cycle (count clock cycles x (ITCMP setting + 1)).
•	
•	
FFFH	
000H	Setting prohibit

Example interrupt cycles when 001H or FFFH is specified for ITCMP11 to ITCMP0

- ITCMP11 to ITCMP0 = 001H, count clock: when $f_{SUB} = 32.768 \text{ kHz}$
 $1/32.768 \text{ [kHz]} \times (1 + 1) = 0.06103515625 \text{ [ms]} \cong 61.03 \text{ [}\mu\text{s]}$
- ITCMP11 to ITCMP0 = FFFH, count clock: when $f_{SUB} = 32.768 \text{ kHz}$
 $1/32.768 \text{ [kHz]} \times (4095 + 1) = 125 \text{ [ms]}$

- Cautions**
1. Before changing the RINTE bit from 1 to 0, use the interrupt mask flag register to disable the INTIT interrupt servicing. When the operation starts (from 0 to 1) again, clear the ITIF flag, and then enable the interrupt servicing.
 2. The value read from the RINTE bit is applied one count clock cycle after setting the RINTE bit.
 3. When setting the RINTE bit after returned from standby mode and entering standby mode again, confirm that the written value of the RINTE bit is reflected, or wait that more than one clock of the count clock has elapsed after returned from standby mode. Then enter standby mode.
 4. Only change the setting of the ITCMP11 to ITCMP0 bits when RINTE = 0. However, it is possible to change the settings of the ITCMP11 to ITCMP0 bits at the same time as when changing RINTE from 0 to 1 or 1 to 0.

8.4 12-bit Interval Timer Operation

8.4.1 12-bit interval timer operation timing

The count value specified for the ITCMP11 to ITCMP0 bits is used as an interval to operate an 12-bit interval timer that repeatedly generates interrupt requests (INTIT).

When the RINTE bit is set to 1, the 12-bit counter starts counting.

When the 12-bit counter value matches the value specified for the ITCMP11 to ITCMP0 bits, the 12-bit counter value is cleared to 0, counting continues, and an interrupt request signal (INTIT) is generated at the same time.

The basic operation of the 12-bit interval timer is as follows.

Figure 8-5. 12-bit Interval Timer Operation Timing (ITCMP11 to ITCMP0 = 0FFH, count clock: $f_{SUB} = 32.768$ kHz)

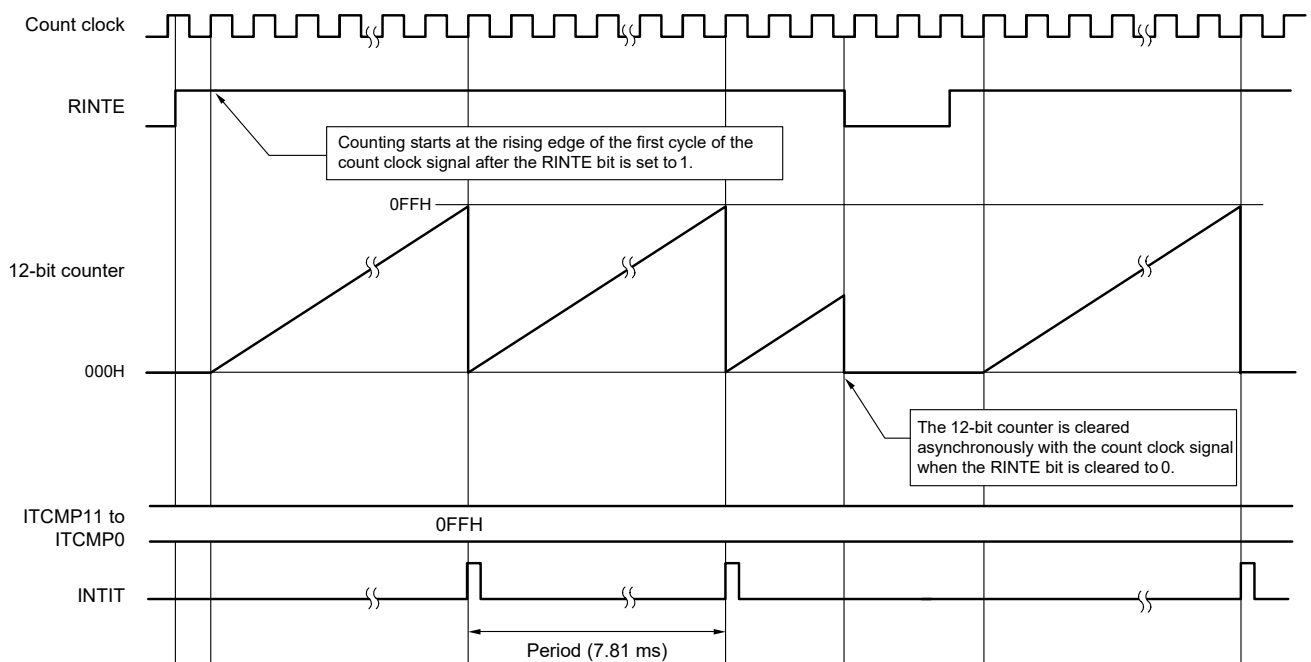

8.4.2 Start of count operation and re-enter to HALT/STOP mode after returned from HALT/STOP mode

When setting the RINTE bit after returned from HALT or STOP mode and entering HALT or STOP mode again, write 1 to the RINTE bit, and confirm the written value of the RINTE bit is reflected or wait for at least one cycle of the count clock. Then, enter HALT or STOP mode.

- After setting RINTE to 1, confirm by polling that the RINTE bit has become 1, and then enter HALT or STOP mode (see Example 1 in Figure 8-6).
- After setting RINTE to 1, wait for at least one cycle of the count clock and then enter HALT or STOP mode (see Example 2 in Figure 8-6).

Figure 8-6. Procedure of entering to HALT or STOP mode after setting RINTE to 1

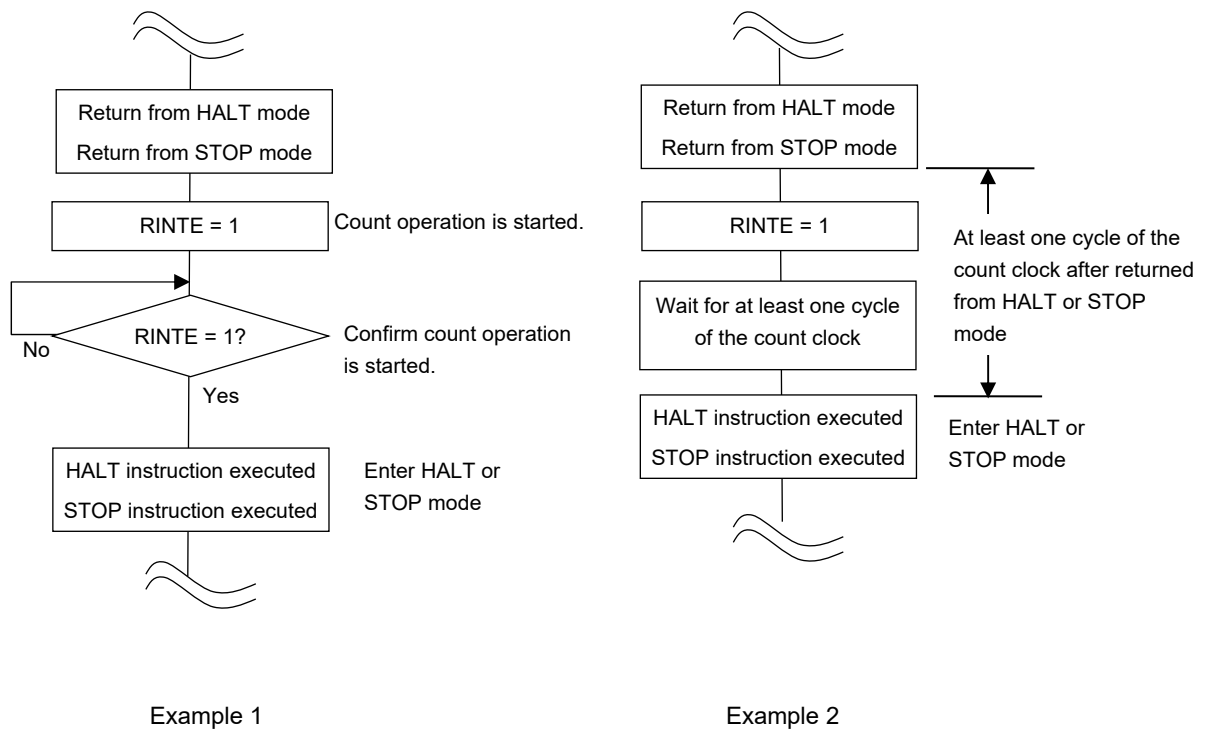

CHAPTER 9 CLOCK OUTPUT/BUZZER OUTPUT CONTROLLER

The number of output pins of the clock output and buzzer output controllers differs, depending on the product.

Output pin	20-pin	24, 25-pin	30, 32, 36, 40, 44, 48, 52, 64, 80, 100, 128-pin
PCLBUZ0	–	√	√
PCLBUZ1	–	–	√

Caution Most of the following descriptions in this chapter use the 64-pin as an example.

9.1 Functions of Clock Output/Buzzer Output Controller

The clock output controller is intended for clock output for supply to peripheral ICs.

Buzzer output is a function to output a square wave of buzzer frequency.

One pin can be used to output a clock or buzzer sound.

Two output pins, PCLBUZ0 and PCLBUZ1, are available.

The PCLBUZn pin outputs a clock selected by clock output select register n (CKSn).

Figure 9-1 shows the block diagram of clock output/buzzer output controller.

Caution It is not possible to output the subsystem clock (f_{SUB}) from the PCLBUZn pin while the RTCLPC bit of the subsystem clock supply mode control register (OSMC), which controls the supply of the subsystem clock, is set to 1 and moreover while HALT mode is set with the subsystem clock (f_{SUB}) selected as CPU clock.

Remark n = 0, 1

Figure 9-1. Block Diagram of Clock Output/Buzzer Output Controller

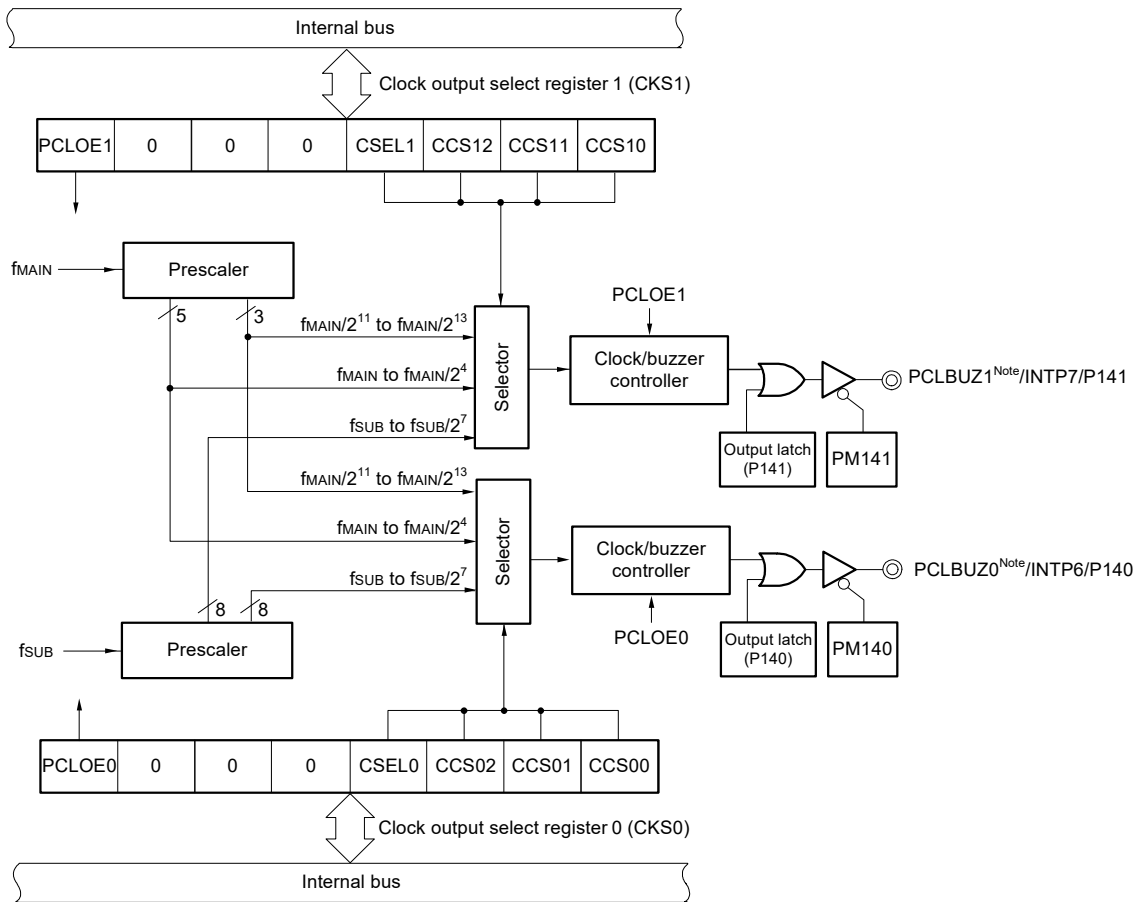

Note For output frequencies available from PCLBUZ0 and PCLBUZ1, refer to **29.4** or **30.4 AC Characteristics**.

Remark The clock output/buzzer output pins in above diagram shows the information of 64- to 128-pins products with PIOR3 = 0 and PIOR4 = 0.

9.2 Configuration of Clock Output/Buzzer Output Controller

The clock output/buzzer output controller includes the following hardware.

Table 9-1. Configuration of Clock Output/Buzzer Output Controller

Item	Configuration
Control registers	Clock output select registers n (CKSn) Port mode register 1, 3, 5, 14 (PM1, PM3, PM5, PM14) Port register 1, 3, 5, 14 (P1, P3, P5, P14)

9.3 Registers Controlling Clock Output/Buzzer Output Controller

The following registers are used to control the clock output/buzzer output controller.

- Clock output select registers n (CKSn)
- Port mode register 1, 3, 5, 14 (PM1, PM3, PM5, PM14)
- Port register 1, 3, 5, 14 (P1, P3, P5, P14)

9.3.1 Clock output select registers n (CKSn)

These registers set output enable/disable for clock output or for the buzzer frequency output pin (PCLBUZn), and set the output clock.

Select the clock to be output from the PCLBUZn pin by using the CKSn register.

The CKSn register are set by a 1-bit or 8-bit memory manipulation instruction.

Reset signal generation clears these registers to 00H.

Figure 9-2. Format of Clock Output Select Register n (CKSn)

Address: FFFA5H (CKS0), FFFA6H (CKS1) After reset: 00H R/W

Symbol	<7>	6	5	4	3	2	1	0
CKSn	PCLOEn	0	0	0	CSELn	CCSn2	CCSn1	CCSn0

PCLOEn	PCLBUZn pin output enable/disable specification
0	Output disable (default)
1	Output enable

CSELn	CCSn2	CCSn1	CCSn0	PCLBUZn pin output clock selection				
				$f_{\text{MAIN}} =$ 5 MHz	$f_{\text{MAIN}} =$ 10 MHz	$f_{\text{MAIN}} =$ 20 MHz	$f_{\text{MAIN}} =$ 32 MHz	
0	0	0	0	f_{MAIN}	5 MHz	10 MHz ^{Note}	Setting prohibited Note	Setting prohibited Note
0	0	0	1	$f_{\text{MAIN}}/2$	2.5 MHz	5 MHz	10 MHz ^{Note}	16 MHz ^{Note}
0	0	1	0	$f_{\text{MAIN}}/2^2$	1.25 MHz	2.5 MHz	5 MHz	8 MHz ^{Note}
0	0	1	1	$f_{\text{MAIN}}/2^3$	625 kHz	1.25 MHz	2.5 MHz	4 MHz
0	1	0	0	$f_{\text{MAIN}}/2^4$	312.5 kHz	625 kHz	1.25 MHz	2 MHz
0	1	0	1	$f_{\text{MAIN}}/2^{11}$	2.44 kHz	4.88 kHz	9.76 kHz	15.63 kHz
0	1	1	0	$f_{\text{MAIN}}/2^{12}$	1.22 kHz	2.44 kHz	4.88 kHz	7.81 kHz
0	1	1	1	$f_{\text{MAIN}}/2^{13}$	610 Hz	1.22 kHz	2.44 kHz	3.91 kHz
1	0	0	0	f_{SUB}	32.768 kHz			
1	0	0	1	$f_{\text{SUB}}/2$	16.384 kHz			
1	0	1	0	$f_{\text{SUB}}/2^2$	8.192 kHz			
1	0	1	1	$f_{\text{SUB}}/2^3$	4.096 kHz			
1	1	0	0	$f_{\text{SUB}}/2^4$	2.048 kHz			
1	1	0	1	$f_{\text{SUB}}/2^5$	1.024 kHz			
1	1	1	0	$f_{\text{SUB}}/2^6$	512 Hz			
1	1	1	1	$f_{\text{SUB}}/2^7$	256 Hz			

Note Use the output clock within a range of 16 MHz. See 29.4 or 30.4 AC Characteristics for details.

- Cautions**
1. Change the output clock after disabling clock output (PCLOEn = 0).
 2. To shift to STOP mode when the main system clock is selected (CSELn = 0), set PCLOEn = 0 before executing the STOP instruction. When the subsystem clock is selected (CSELn = 1), PCLOEn = 1 can be set because the clock can be output while the RTCLPC bit of the subsystem clock supply mode control (OSMC) register (the bit which controls the supply of the subsystem clock) is set to 0 and moreover while STOP mode is set.
 3. It is not possible to output the subsystem clock (f_{SUB}) from the PCLBUZn pin while the RTCLPC bit of the subsystem clock supply mode control register (OSMC), which controls the supply of the subsystem clock, is set to 1 and moreover while HALT mode is set with the subsystem clock (f_{SUB}) selected as CPU clock.

- Remarks**
1. n = 0, 1
 2. f_{MAIN} : Main system clock frequency
 f_{SUB} : Subsystem clock frequency

9.3.2 Registers controlling port functions of pins to be used for clock or buzzer output

Using a port pin for clock or buzzer output requires setting of the registers that control the port functions multiplexed on the target pin (port mode register (PMxx), port register (Pxx)). For details, see **4.3.1 Port mode registers (PMxx)** and **4.3.2 Port registers (Pxx)**.

Specifically, using a port pin with a multiplexed clock or buzzer output function (e.g. P140/INTP6/PCLBUZ0, P141/INTP7/PCLBUZ1) for clock or buzzer output, requires setting the corresponding bits in the port mode register (PMxx) and port register (Pxx) to 0.

Example: When P140/INTP6/PCLBUZ0 is to be used for clock or buzzer output

Set the PM140 bit of port mode register 14 to 0.

Set the P140 bit of port register 14 to 0.

9.4 Operations of Clock Output/Buzzer Output Controller

One pin can be used to output a clock or buzzer sound.

The PCLBUZ0 pin outputs a clock/buzzer selected by the clock output select register 0 (CKS0).

The PCLBUZ1 pin outputs a clock/buzzer selected by the clock output select register 1 (CKS1).

9.4.1 Operation as output pin

The PCLBUZn pin is output as the following procedure.

- <1> Set 0 in the bit of the port mode register (PMxx) and port register (Px) which correspond to the port which has a pin used as the PCLBUZ0 pin.
- <2> Select the output frequency with bits 0 to 3 (CCSn0 to CCSn2, CSELn) of the clock output select register (CKSn) of the PCLBUZn pin (output in disabled status).
- <3> Set bit 7 (PCLOEn) of the CKSn register to 1 to enable clock/buzzer output.

Remarks 1. The controller used for outputting the clock starts or stops outputting the clock one clock after enabling or disabling clock output (PCLOEn bit) is switched. At this time, pulses with a narrow width are not output. Figure 9-3 shows enabling or stopping output using the PCLOEn bit and the timing of outputting the clock.

2. n = 0, 1

Figure 9-3. Timing of Outputting Clock from PCLBUZn Pin

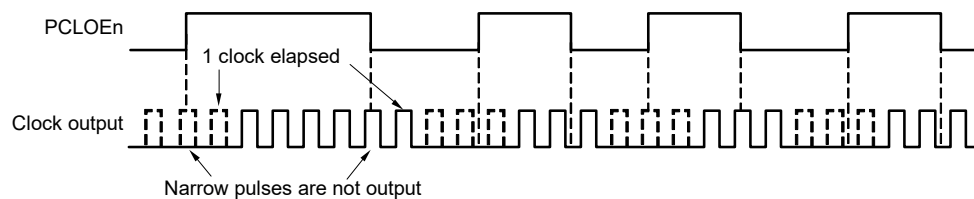

9.5 Cautions of clock output/buzzer output controller

When the main system clock is selected for the PCLBUZn output (CSEL = 0), if STOP mode is entered within 1.5 clock cycles output from the PCLBUZn pin after the output is disabled (PCLOEn = 0), the PCLBUZn output width becomes shorter.

CHAPTER 10 WATCHDOG TIMER

10.1 Functions of Watchdog Timer

The counting operation of the watchdog timer is set by the option byte (000C0H).

The watchdog timer operates on the low-speed on-chip oscillator clock (f_{IL}).

The watchdog timer is used to detect an inadvertent program loop. If a program loop is detected, an internal reset signal is generated.

Program loop is detected in the following cases.

- If the watchdog timer counter overflows
- If a 1-bit manipulation instruction is executed on the watchdog timer enable register (WDTE)
- If data other than "ACH" is written to the WDTE register
- If data is written to the WDTE register during a window close period

When a reset occurs due to the watchdog timer, bit 4 (WDTRF) of the reset control flag register (RESF) is set to 1. For details of the RESF register, see **CHAPTER 19 RESET FUNCTION**.

When 75% of the overflow time + $1/2 f_{IL}$ is reached, an interval interrupt can be generated.

10.2 Configuration of Watchdog Timer

The watchdog timer includes the following hardware.

Table 10-1. Configuration of Watchdog Timer

Item	Configuration
Counter	Internal counter (17 bits)
Control register	Watchdog timer enable register (WDTE)

How the counter operation is controlled, overflow time, window open period, and interval interrupt are set by the option byte.

Table 10-2. Setting of Option Bytes and Watchdog Timer

Setting of Watchdog Timer	Option Byte (000C0H)
Watchdog timer interval interrupt	Bit 7 (WDTINT)
Window open period	Bits 6 and 5 (WINDOW1, WINDOW0)
Controlling counter operation of watchdog timer	Bit 4 (WDTON)
Overflow time of watchdog timer	Bits 3 to 1 (WDCS2 to WDCS0)
Controlling counter operation of watchdog timer (in HALT/STOP mode)	Bit 0 (WDSTBYON)

Remark For the option byte, see **CHAPTER 24 OPTION BYTE**.

Figure 10-1. Block Diagram of Watchdog Timer

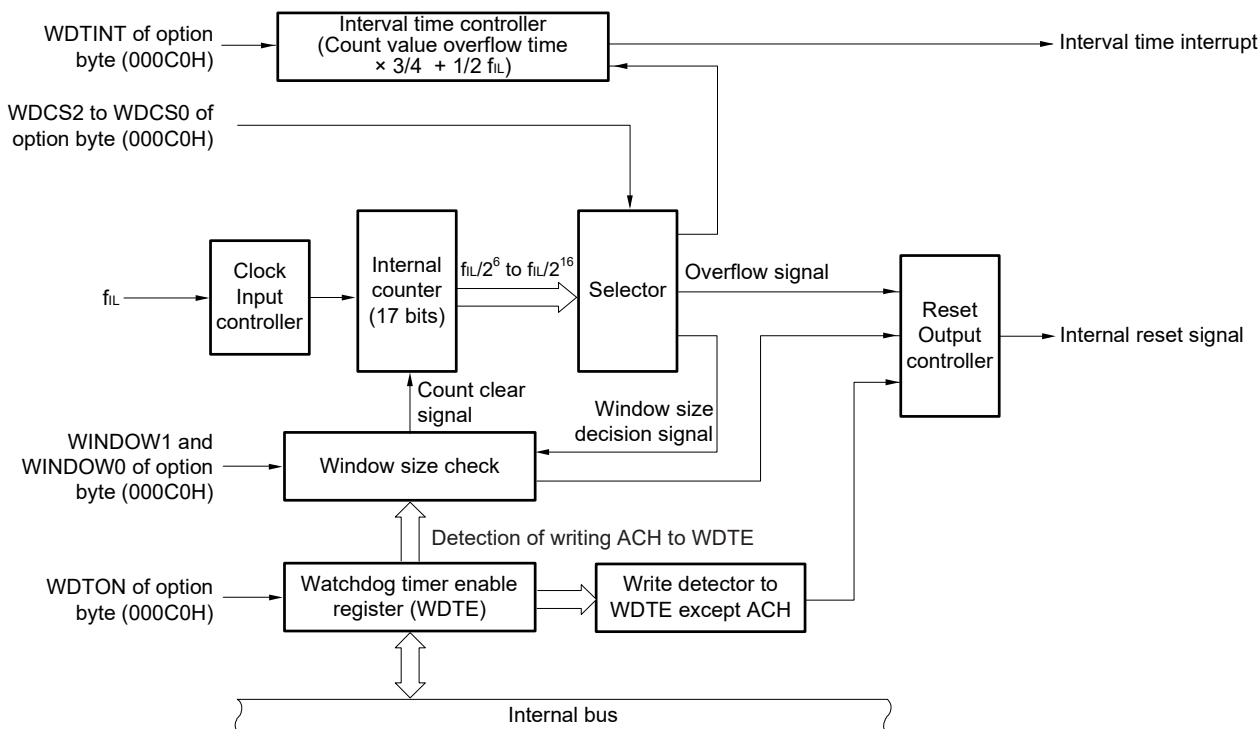

Remark fil: Low-speed on-chip oscillator clock

10.3 Register Controlling Watchdog Timer

The watchdog timer is controlled by the watchdog timer enable register (WDTE).

10.3.1 Watchdog timer enable register (WDTE)

Writing “ACH” to the WDTE register clears the watchdog timer counter and starts counting again.

This register can be set by an 8-bit memory manipulation instruction.

Reset signal generation sets this register to 9AH or 1AH^{Note}.

Figure 10-2. Format of Watchdog Timer Enable Register (WDTE)

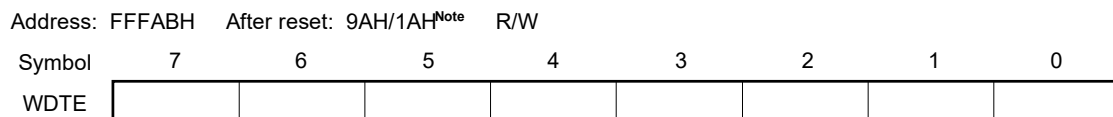

Note The WDTE register reset value differs depending on the WDTON bit setting value of the option byte (000C0H). To operate watchdog timer, set the WDTON bit to 1.

WDTON Bit Setting Value	WDTE Register Reset Value
0 (watchdog timer count operation disabled)	1AH
1 (watchdog timer count operation enabled)	9AH

- Cautions**
1. If a value other than “ACH” is written to the WDTE register, an internal reset signal is generated.
 2. If a 1-bit memory manipulation instruction is executed for the WDTE register, an internal reset signal is generated.
 3. The value read from the WDTE register is 9AH/1AH (this differs from the written value (ACH)).

10.4 Operation of Watchdog Timer

10.4.1 Controlling operation of watchdog timer

- When the watchdog timer is used, its operation is specified by the option byte (000C0H).
 - Enable counting operation of the watchdog timer by setting bit 4 (WDTON) of the option byte (000C0H) to 1 (the counter starts operating after a reset release) (for details, see **CHAPTER 24**).

WDTON	Watchdog Timer Counter
0	Counter operation disabled (counting stopped after reset)
1	Counter operation enabled (counting started after reset)

- Set an overflow time by using bits 3 to 1 (WDCS2 to WDCS0) of the option byte (000C0H) (for details, see **10.4.2** and **CHAPTER 24**).
 - Set a window open period by using bits 6 and 5 (WINDOW1 and WINDOW0) of the option byte (000C0H) (for details, see **10.4.3** and **CHAPTER 24**).
- After a reset release, the watchdog timer starts counting.
 - By writing "ACH" to the watchdog timer enable register (WDTE) after the watchdog timer starts counting and before the overflow time set by the option byte, the watchdog timer is cleared and starts counting again.
 - After that, write the WDTE register the second time or later after a reset release during the window open period. If the WDTE register is written during a window close period, an internal reset signal is generated.
 - If the overflow time expires without "ACH" written to the WDTE register, an internal reset signal is generated. An internal reset signal is generated in the following cases.
 - If a 1-bit manipulation instruction is executed on the WDTE register
 - If data other than "ACH" is written to the WDTE register

- Cautions**
- When data is written to the watchdog timer enable register (WDTE) for the first time after reset release, the watchdog timer is cleared in any timing regardless of the window open time, as long as the register is written before the overflow time, and the watchdog timer starts counting again.
 - After "ACH" is written to the WDTE register, an error of up to 2 clocks (t_{IL}) may occur before the watchdog timer is cleared.
 - The watchdog timer can be cleared immediately before the count value overflows.

Cautions 4. The operation of the watchdog timer in the HALT, STOP, and SNOOZE modes differs as follows depending on the set value of bit 0 (WDSTBYON) of the option byte (000C0H).

	WDSTBYON = 0	WDSTBYON = 1
In HALT mode	Watchdog timer operation stops.	Watchdog timer operation continues.
In STOP mode		
In SNOOZE mode		

If **WDSTBYON = 0**, the watchdog timer resumes counting after the HALT or STOP mode is released. At this time, the counter is cleared to 0 and counting starts.

When operating with the X1 oscillation clock after releasing the STOP mode, the CPU starts operating after the oscillation stabilization time has elapsed.

Therefore, if the period between the STOP mode release and the watchdog timer overflow is short, an overflow occurs during the oscillation stabilization time, causing a reset.

Consequently, set the overflow time in consideration of the oscillation stabilization time when operating with the X1 oscillation clock and when the watchdog timer is to be cleared after the STOP mode release by an interval interrupt.

10.4.2 Setting overflow time of watchdog timer

Set the overflow time of the watchdog timer by using bits 3 to 1 (WDCS2 to WDCS0) of the option byte (000C0H).

If an overflow occurs, an internal reset signal is generated. The present count is cleared and the watchdog timer starts counting again by writing "ACH" to the watchdog timer enable register (WDTE) during the window open period before the overflow time.

The following overflow times can be set.

Table 10-3. Setting of Overflow Time of Watchdog Timer

WDCS2	WDCS1	WDCS0	Overflow Time of Watchdog Timer (f _{IL} = 17.25 kHz (MAX.))
0	0	0	2 ⁶ /f _{IL} (3.71 ms)
0	0	1	2 ⁷ /f _{IL} (7.42 ms)
0	1	0	2 ⁸ /f _{IL} (14.84 ms)
0	1	1	2 ⁹ /f _{IL} (29.68 ms)
1	0	0	2 ¹¹ /f _{IL} (118.72 ms)
1	0	1	2 ¹³ /f _{IL} (474.89 ms) ^{Note}
1	1	0	2 ¹⁴ /f _{IL} (949.79 ms) ^{Note}
1	1	1	2 ¹⁶ /f _{IL} (3799.18 ms) ^{Note}

Note Using the watchdog timer under the following conditions may lead to the generation of an interval interrupt (INTWDTI) after one cycle of the watchdog timer clock once the watchdog timer counter has been cleared.

Usage conditions that may lead to the generation of an interval interrupt:

- The overflow time of the watchdog timer is set to 2¹³/f_{IL}, 2¹⁴/f_{IL}, or 2¹⁶/f_{IL},
- the interval interrupt is in use (the setting of the WDTINT bit of the relevant option byte is 1), and
- ACH is written to the WDTE register (FFFABH) when the watchdog timer counter has reached or exceeded 75% of the overflow time.

This interrupt can be masked by clearing the watchdog timer counter through steps 1 to 5 below.

1. Set the WDTIMK bit of the interrupt mask flag register 0 (MK0L) to 1 before clearing the watchdog timer counter.
2. Clear the watchdog timer counter.
3. Wait for at least 80 μs.
4. Clear the WDTIIF bit of the interrupt request flag register (IF0L) to 0.
5. Clear the WDTIMK bit of the interrupt mask flag register 0 (MK0L) to 0.

Remark f_{IL}: Low-speed on-chip oscillator clock frequency

10.4.3 Setting window open period of watchdog timer

Set the window open period of the watchdog timer by using bits 6 and 5 (WINDOW1, WINDOW0) of the option byte (000C0H). The outline of the window is as follows.

- If "ACH" is written to the watchdog timer enable register (WDTE) during the window open period, the watchdog timer is cleared and starts counting again.
- Even if "ACH" is written to the WDTE register during the window close period, an abnormality is detected and an internal reset signal is generated.

Example: If the window open period is 50%

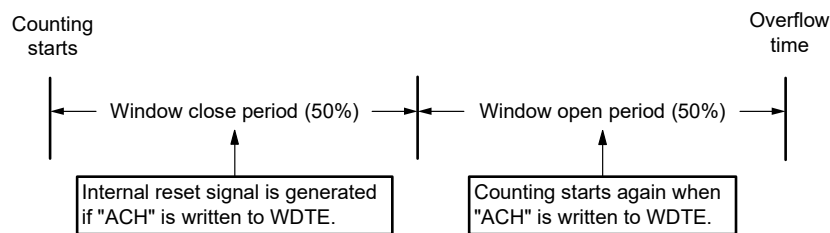

Caution When data is written to the WDTE register for the first time after reset release, the watchdog timer is cleared in any timing regardless of the window open time, as long as the register is written before the overflow time, and the watchdog timer starts counting again.

The window open period can be set is as follows.

Table 10-4. Setting Window Open Period of Watchdog Timer

WINDOW1	WINDOW0	Window Open Period of Watchdog Timer
0	0	Setting prohibited
0	1	50%
1	0	75% <i>Note</i>
1	1	100%

Note When the window open period is set to 75%, clearing the counter of the watchdog timer (writing ACH to WDTE) must proceed outside the corresponding period from among those listed below, over which clearing of the counter is prohibited (for example, confirming that the interval timer interrupt request flag (WDTIIF) of the watchdog timer is set).

WDCS2	WDCS1	WDCS0	Watchdog timer overflow time ($f_{IL} = 17.25 \text{ kHz (MAX.)}$)	Period over which clearing the counter is prohibited when the window open period is set to 75%
0	0	0	$2^6/f_{IL}$ (3.71 ms)	1.85 ms to 2.51 ms
0	0	1	$2^7/f_{IL}$ (7.42 ms)	3.71 ms to 5.02 ms
0	1	0	$2^8/f_{IL}$ (14.84 ms)	7.42 ms to 10.04 ms
0	1	1	$2^9/f_{IL}$ (29.68 ms)	14.84 ms to 20.08 ms
1	0	0	$2^{11}/f_{IL}$ (118.72 ms)	56.36 ms to 80.32 ms
1	0	1	$2^{13}/f_{IL}$ (474.89 ms)	237.44 ms to 321.26 ms
1	1	0	$2^{14}/f_{IL}$ (949.79 ms)	474.89 ms to 642.51 ms
1	1	1	$2^{16}/f_{IL}$ (3799.18 ms)	1899.59 ms to 2570.04 ms

Caution When bit 0 (WDSTBYON) of the option byte (000C0H) = 0, the window open period is 100% regardless of the values of the WINDOW1 and WINDOW0 bits.

Remark If the overflow time is set to $2^9/f_{IL}$, the window close time and open time are as follows.

	Setting of Window Open Period		
	50%	75%	100%
Window close time	0 to 20.08 ms	0 to 10.04 ms	None
Window open time	20.08 to 29.68 ms	10.04 to 29.68 ms	0 to 29.68 ms

<When window open period is 50%>

- Overflow time:
 $2^9/f_{IL} \text{ (MAX.)} = 2^9/17.25 \text{ kHz} = 29.68 \text{ ms}$
- Window close time:
 $0 \text{ to } 2^9/f_{IL} \text{ (MIN.)} \times (1 - 0.5) = 0 \text{ to } 2^9/12.75 \text{ kHz} \times 0.5 = 0 \text{ to } 20.08 \text{ ms}$
- Window open time:
 $2^9/f_{IL} \text{ (MIN.)} \times (1 - 0.5) \text{ to } 2^9/f_{IL} \text{ (MAX.)} = 2^9/12.75 \text{ kHz} \times 0.5 \text{ to } 2^9/17.25 \text{ kHz} = 20.08 \text{ to } 29.68 \text{ ms}$

10.4.4 Setting watchdog timer interval interrupt

Depending on the setting of bit 7 (WDTINT) of an option byte (000C0H), an interval interrupt (INTWDTI) can be generated when 75% of the overflow time + 1/2 f_{IL} is reached.

Table 10-5. Setting of Watchdog Timer Interval Interrupt

WDTINT	Use of Watchdog Timer Interval Interrupt
0	Interval interrupt is not used.
1	Interval interrupt is generated when 75% of the overflow time + 1/2 f_{IL} is reached.

Caution When operating with the X1 oscillation clock after releasing the STOP mode, the CPU starts operating after the oscillation stabilization time has elapsed. Therefore, if the period between the STOP mode release and the watchdog timer overflow is short, an overflow occurs during the oscillation stabilization time, causing a reset. Consequently, set the overflow time in consideration of the oscillation stabilization time when operating with the X1 oscillation clock and when the watchdog timer is to be cleared after the STOP mode release by an interval interrupt.

Remark The watchdog timer continues counting even after INTWDTI is generated (until ACH is written to the watchdog timer enable register (WDTE)). If ACH is not written to the WDTE register before the overflow time, an internal reset signal is generated.

CHAPTER 11 A/D CONVERTER

The number of analog input channels of the A/D converter differs, depending on the product.

	20, 24, 25-pin	30, 32-pin	36-pin	40-pin	44, 48-pin	52, 64-pin	80-pin	100-pin	128-pin
Analog input channels	6 ch (ANI0 to ANI2, ANI16 to ANI18)	8 ch (ANI0 to ANI3, ANI16 to ANI19)	8 ch (ANI0 to ANI5, ANI18, ANI19)	9 ch (ANI0 to ANI6, ANI18, ANI19)	10 ch (ANI0 to ANI7, ANI18, ANI19)	12 ch (ANI0 to ANI7, ANI16 to ANI19)	17 ch (ANI0 to ANI11, ANI16 to ANI20)	20 ch (ANI0 to ANI14, ANI16 to ANI20)	26 ch (ANI0 to ANI14, ANI16 to ANI26)

11.1 Function of A/D Converter

The A/D converter is used to convert analog input signals into digital values, and is configured to control analog inputs, including up to 26 channels of A/D converter analog inputs (ANI0 to ANI14 and ANI16 to ANI26). 10-bit or 8-bit resolution can be selected by the ADTYP bit of the A/D converter mode register 2 (ADM2).

The A/D converter has the following function.

- **10-bit/8-bit resolution A/D conversion**

10-bit or 8-bit resolution A/D conversion is carried out repeatedly for one analog input channel selected from ANI0 to ANI14 and ANI16 to ANI26. Each time an A/D conversion operation ends, an interrupt request (INTAD) is generated (when in the select mode).

Various A/D conversion modes can be specified by using the mode combinations below.

Trigger mode	Software trigger	Conversion is started by software.
	Hardware trigger no-wait mode	Conversion is started by detecting a hardware trigger.
	Hardware trigger wait mode	The power is turned on by detecting a hardware trigger while the system is off and in the conversion standby state, and conversion is then started automatically after the stabilization wait time passes. When using the SNOOZE mode function, specify the hardware trigger wait mode.
Channel selection mode	Select mode	A/D conversion is performed on the analog input of one selected channel.
	Scan mode	A/D conversion is performed on the analog input of four channels in order. Four consecutive channels can be selected from ANI0 to ANI14 as analog input channels.
Conversion operation mode	One-shot conversion mode	A/D conversion is performed on the selected channel once.
	Sequential conversion mode	A/D conversion is sequentially performed on the selected channels until it is stopped by software.
Operation voltage mode	Standard 1 or standard 2 mode	Conversion is done in the operation voltage range of $2.7\text{ V} \leq V_{DD} \leq 5.5\text{ V}$.
	Low voltage 1 or low voltage 2 mode	Conversion is done in the operation voltage range of $1.6\text{ V} \leq V_{DD} \leq 5.5\text{ V}$. Select this mode for conversion at a low voltage. Because the operation voltage is low, it is internally boosted during conversion.
Sampling time selection	Sampling clock cycles: 7 f_{AD}	The sampling time in standard 1 or low voltage 1 mode is seven cycles of the conversion clock (f_{AD}). Select this mode when the output impedance of the analog input source is high and the sampling time should be long.
	Sampling clock cycles: 5 f_{AD}	The sampling time in standard 2 or low voltage 2 mode is five cycles of the conversion clock (f_{AD}). Select this mode when enough sampling time is ensured (for example, when the output impedance of the analog input source is low).

Figure 11-1. Block Diagram of A/D Converter

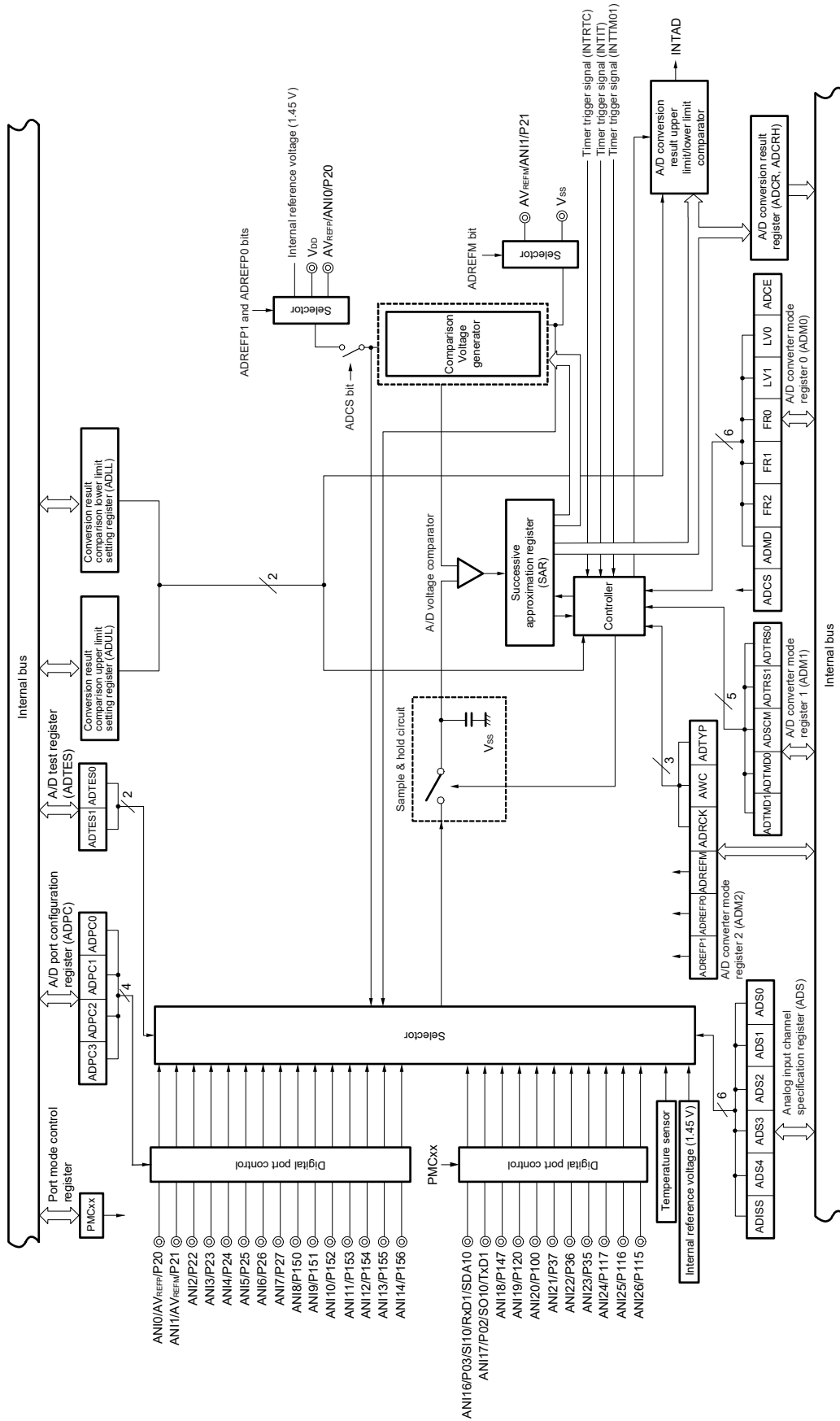

Remark Analog input pins in this figure are for a 128-pin product.

11.2 Configuration of A/D Converter

The A/D converter includes the following hardware.

(1) ANI0 to ANI14 and ANI16 to ANI26 pins

These are the analog input pins of the 26 channels of the A/D converter. They input analog signals to be converted into digital signals. Pins other than the one selected as the analog input pin can be used as I/O port pins.

(2) Sample & hold circuit

The sample & hold circuit samples each of the analog input voltages sequentially sent from the input circuit, and sends them to the A/D voltage comparator. This circuit also holds the sampled analog input voltage during A/D conversion.

(3) A/D voltage comparator

This A/D voltage comparator compares the voltage generated from the voltage tap of the comparison voltage generator with the analog input voltage. If the analog input voltage is found to be greater than the reference voltage ($1/2 AV_{REF}$) as a result of the comparison, the most significant bit (MSB) of the successive approximation register (SAR) is set. If the analog input voltage is less than the reference voltage ($1/2 AV_{REF}$), the MSB bit of the SAR is reset.

After that, bit 8 of the SAR register is automatically set, and the next comparison is made. The voltage tap of the comparison voltage generator is selected by the value of bit 9, to which the result has been already set.

Bit 9 = 0: ($1/4 AV_{REF}$)

Bit 9 = 1: ($3/4 AV_{REF}$)

The voltage tap of the comparison voltage generator and the analog input voltage are compared and bit 8 of the SAR register is manipulated according to the result of the comparison.

Analog input voltage \geq Voltage tap of comparison voltage generator: Bit 8 = 1

Analog input voltage \leq Voltage tap of comparison voltage generator: Bit 8 = 0

Comparison is continued like this to bit 0 of the SAR register.

When performing A/D conversion at a resolution of 8 bits, the comparison continues until bit 2 of the SAR register.

Remark AV_{REF} : The + side reference voltage of the A/D converter. This can be selected from AV_{REFP} , the internal reference voltage (1.45 V), and V_{DD} .

(4) Comparison voltage generator

The comparison voltage generator generates the comparison voltage input from an analog input pin.

(5) Successive approximation register (SAR)

The SAR register is a register that sets voltage tap data whose values from the comparison voltage generator match the voltage values of the analog input pins, 1 bit at a time starting from the most significant bit (MSB).

If data is set in the SAR register all the way to the least significant bit (LSB) (end of A/D conversion), the contents of the SAR register (conversion results) are held in the A/D conversion result register (ADCR). When all the specified A/D conversion operations have ended, an A/D conversion end interrupt request signal (INTAD) is generated.

(6) 10-bit A/D conversion result register (ADCR)

The A/D conversion result is loaded from the successive approximation register to this register each time A/D conversion is completed, and the ADCR register holds the A/D conversion result in its higher 10 bits (the lower 6 bits are fixed to 0).

(7) 8-bit A/D conversion result register (ADCRH)

The A/D conversion result is loaded from the successive approximation register to this register each time A/D conversion is completed, and the ADCRH register stores the higher 8 bits of the A/D conversion result.

(8) Controller

This circuit controls the conversion time of an input analog signal that is to be converted into a digital signal, as well as starting and stopping of the conversion operation. When A/D conversion has been completed, this controller generates INTAD through the A/D conversion result upper limit/lower limit comparator.

(9) AV_{REFP} pin

This pin inputs an external reference voltage (AV_{REFP}).

If using AV_{REFP} as the + side reference voltage of the A/D converter, set the ADREFP1 and ADREFP0 bits of A/D converter mode register 2 (ADM2) to 0 and 1, respectively.

The analog signals input to ANI2 to ANI14 and ANI16 to ANI26 are converted to digital signals based on the voltage applied between AV_{REFP} and the – side reference voltage (AV_{REFM}/V_{SS}).

In addition to AV_{REFP}, it is possible to select V_{DD} or the internal reference voltage (1.45 V) as the + side reference voltage of the A/D converter.

(10) AV_{REFM} pin

This pin inputs an external reference voltage (AV_{REFM}). If using AV_{REFM} as the – side reference voltage of the A/D converter, set the ADREFM bit of the ADM2 register to 1.

In addition to AV_{REFM}, it is possible to select V_{SS} as the – side reference voltage of the A/D converter.

11.3 Registers Controlling A/D Converter

The A/D converter is controlled by the following registers.

- Peripheral enable register 0 (PER0)
- A/D converter mode register 0 (ADM0)
- A/D converter mode register 1 (ADM1)
- A/D converter mode register 2 (ADM2)
- 10-bit A/D conversion result register (ADCR)
- 8-bit A/D conversion result register (ADCRH)
- Analog input channel specification register (ADS)
- Conversion result comparison upper limit setting register (ADUL)
- Conversion result comparison lower limit setting register (ADLL)
- A/D test register (ADTES)
- A/D port configuration register (ADPC)
- Port mode control registers 0, 3, 10, 11, 12, and 14 (PMC0, PMC3, PMC10, PMC11, PMC12, PMC14)
- Port mode registers 0, 2, 3, 10, 11, 12, 14, and 15 (PM0, PM2, PM3, PM10, PM11, PM12, PM14, PM15)

11.3.1 Peripheral enable register 0 (PER0)

This register is used to enable or disable supplying the clock to the peripheral hardware. Clock supply to a hardware macro that is not used is stopped in order to reduce the power consumption and noise.

When the A/D converter is used, be sure to set bit 5 (ADCEN) of this register to 1.

The PER0 register can be set by a 1-bit or 8-bit memory manipulation instruction.

Reset signal generation clears this register to 00H.

Figure 11-2. Format of Peripheral Enable Register 0 (PER0)

Address: F00F0H After reset: 00H R/W

Symbol	<7>	<6>	<5>	<4>	<3>	<2>	<1>	<0>
PER0	RTCEN	IICA1EN <small>Note 1</small>	ADCEN	IICA0EN <small>Note 2</small>	SAU1EN <small>Note 3</small>	SAU0EN	TAU1EN <small>Note 1</small>	TAU0EN

ADCEN	Control of A/D converter input clock supply
0	Stops input clock supply. <ul style="list-style-type: none"> • SFR used by the A/D converter cannot be written. • The A/D converter is in the reset status.
1	Enables input clock supply. <ul style="list-style-type: none"> • SFR used by the A/D converter can be read/written.

- Notes**
1. 80, 100, and 128-pin products only.
 2. This is not provided in the 20-pin products.
 3. This is not provided in the 20, 24, and 25-pin products.

- Cautions**
1. When setting the A/D converter, be sure to set the following registers first while the ADCEN bit is set to 1. If ADCEN = 0, the values of the A/D converter control registers are cleared to their initial values and writing to them is ignored (except for port mode registers 0, 2, 3, 10, 11, 12, 14, and 15 (PM0, PM2, PM3, PM10, PM11, PM12, PM14, and PM15), port mode control registers 0, 3, 10, 11, 12, and 14 (PMC0, PMC3, PMC10, PMC11, PMC12, and PMC14), and A/D port configuration register (ADPC)).
 - A/D converter mode register 0 (ADM0)
 - A/D converter mode register 1 (ADM1)
 - A/D converter mode register 2 (ADM2)
 - 10-bit A/D conversion result register (ADCR)
 - 8-bit A/D conversion result register (ADCRH)
 - Analog input channel specification register (ADS)
 - Conversion result comparison upper limit setting register (ADUL)
 - Conversion result comparison lower limit setting register (ADLL)
 - A/D test register (ADTES).
 2. Be sure to clear the following bits to 0.

20-pin products:	bits 1, 3, 4, 6
24, 25-pin products:	bits 1, 3, 6
30, 32, 36, 40, 44, 48, 52, 64-pin products:	bits 1, 6

11.3.2 A/D converter mode register 0 (ADM0)

This register sets the conversion time for analog input to be A/D converted, and starts/stops conversion.

The ADM0 register can be set by a 1-bit or 8-bit memory manipulation instruction.

Reset signal generation clears this register to 00H.

Figure 11-3. Format of A/D Converter Mode Register 0 (ADM0)

Address: FFF30H After reset: 00H R/W

Symbol	<7>	6	5	4	3	2	1	<0>
ADM0	ADCS	ADMD	FR2 ^{Note 1}	FR1 ^{Note 1}	FR0 ^{Note 1}	LV1 ^{Note 1}	LV0 ^{Note 1}	ADCE

ADCS	A/D conversion operation control
0	Stops conversion operation [When read] Conversion stopped/standby status
1	Enables conversion operation [When read] While in the software trigger mode: Conversion operation status While in the hardware trigger wait mode: A/D power supply stabilization wait status + conversion operation status

ADMD	Specification of the A/D conversion channel selection mode
0	Select mode
1	Scan mode

ADCE	A/D voltage comparator operation control ^{Note 2}
0	Stops A/D voltage comparator operation
1	Enables A/D voltage comparator operation

- Notes**
1. For details of the FR2 to FR0, LV1, LV0 bits, and A/D conversion, see **Table 11-3 A/D Conversion Time Selection**.
 2. While in the software trigger mode or hardware trigger no-wait mode, the operation of the A/D voltage comparator is controlled by the ADCS and ADCE bits, and it takes 1 μs from the start of operation for the operation to stabilize. Therefore, when the ADCS bit is set to 1 after 1 μs or more has elapsed from the time ADCE bit is set to 1, the conversion result at that time has priority over the first conversion result. Otherwise, ignore data of the first conversion.

- Cautions**
1. Change the ADMD, FR2 to FR0, LV1, and LV0 bits while conversion is stopped (ADCS = 0, ADCE = 0).
 2. Do not set the ADCS bit to 1 and the ADCE bit to 0 at the same time.
 3. Do not change the ADCS and ADCE bits from 0 to 1 at the same time by using an 8-bit manipulation instruction. Be sure to set these bits in the order described in **11.7 A/D Converter Setup Flowchart**.

Table 11-1. Settings of ADCS and ADCE Bits

ADCS	ADCE	A/D Conversion Operation
0	0	Conversion stopped state
0	1	Conversion standby state
1	0	Setting prohibited
1	1	Conversion-in-progress state

Table 11-2. Setting and Clearing Conditions for ADCS Bit

A/D Conversion Mode			Set Conditions	Clear Conditions
Software trigger	Select mode	Sequential conversion mode	When 1 is written to ADCS	When 0 is written to ADCS
		One-shot conversion mode		<ul style="list-style-type: none"> When 0 is written to ADCS The bit is automatically cleared to 0 when A/D conversion ends.
	Scan mode	Sequential conversion mode		When 0 is written to ADCS
		One-shot conversion mode		<ul style="list-style-type: none"> When 0 is written to ADCS The bit is automatically cleared to 0 when conversion ends on the specified four channels.
Hardware trigger no-wait mode	Select mode	Sequential conversion mode		When 0 is written to ADCS
		One-shot conversion mode		When 0 is written to ADCS
	Scan mode	Sequential conversion mode		When 0 is written to ADCS
		One-shot conversion mode		When 0 is written to ADCS
Hardware trigger wait mode	Select mode	Sequential conversion mode	When a hardware trigger is input	When 0 is written to ADCS
		One-shot conversion mode		<ul style="list-style-type: none"> When 0 is written to ADCS The bit is automatically cleared to 0 when A/D conversion ends.
	Scan mode	Sequential conversion mode		When 0 is written to ADCS
		One-shot conversion mode		<ul style="list-style-type: none"> When 0 is written to ADCS The bit is automatically cleared to 0 when conversion ends on the specified four channels.

Figure 11-4. Timing Chart When A/D Voltage Comparator Is Used

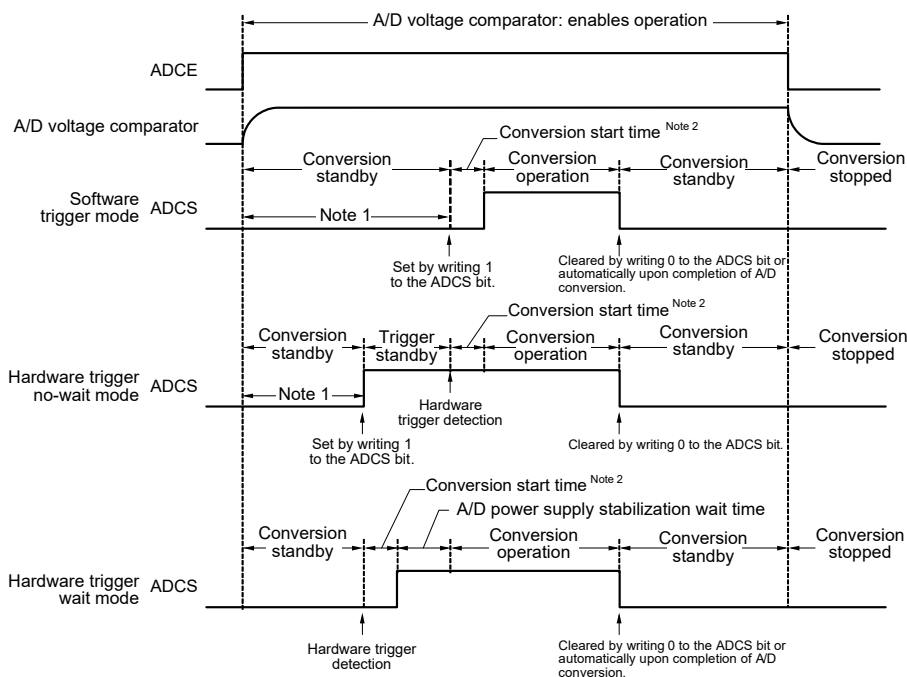

- Notes 1.** While in the software trigger mode or hardware trigger no-wait mode, the time from the rising of the ADCE bit to the rising of the ADCS bit must be 1 μ s or longer to stabilize the internal circuit.
- 2.** In starting conversion, the longer will take up to following time

ADM0			Conversion Clock (f_{AD})	Conversion Start Time (Number of f_{CLK} Clock	
FR2	FR1	FR0		Software Trigger Mode/ Hardware Trigger No-wait Mode	Hardware Trigger Wait Mode
0	0	0	$f_{CLK}/64$	63	1
0	0	1	$f_{CLK}/32$	31	
0	1	0	$f_{CLK}/16$	15	
0	1	1	$f_{CLK}/8$	7	
1	0	0	$f_{CLK}/6$	5	
1	0	1	$f_{CLK}/5$	4	
1	1	0	$f_{CLK}/4$	3	
1	1	1	$f_{CLK}/2$	1	

However, for the second and subsequent conversion in sequential conversion mode and for conversion of the channel specified by scan 1, 2, and 3 in scan mode, the conversion start time and stabilization wait time for A/D power supply do not occur after a hardware trigger is detected.

- Cautions 1.** If using the hardware trigger wait mode, setting the ADCS bit to 1 is prohibited (but the bit is automatically switched to 1 when the hardware trigger signal is detected). However, it is possible to clear the ADCS bit to 0 to specify the A/D conversion standby status.
- 2.** While in the one-shot conversion mode of the hardware trigger no-wait mode, the ADCS flag is not automatically cleared to 0 when A/D conversion ends. Instead, 1 is retained.
- Cautions 3** Only rewrite the value of the ADCE bit when ADCS = 0 (while in the conversion stopped/conversion standby status).
- 4.** To complete A/D conversion, specify at least the following time as the hardware trigger interval:
 Hardware trigger no wait mode: 2 f_{CLK} clock + A/D conversion time

Hardware trigger wait mode: $2 f_{\text{CLK}}$ clock + stabilization wait time + A/D conversion time

Remark f_{CLK} : CPU/peripheral hardware clock frequency

Table 11-3. A/D Conversion Time Selection (1/4)

(1) When there is no A/D power supply stabilization wait time
 Normal mode 1, 2 (software trigger mode/hardware trigger no-wait mode)

A/D Converter Mode Register 0 (ADM0)					Mode	Conversion Clock (f _{AD})	Number of Conversion Clock ^{Note}	Conversion Time	Conversion Time at 10-Bit Resolution					
FR2	FR1	FR0	LV1	LV0					2.7 V ≤ V _{DD} ≤ 5.5 V					
									f _{CLK} = 1 MHz	f _{CLK} = 4 MHz	f _{CLK} = 8 MHz	f _{CLK} = 16 MHz	f _{CLK} = 32 MHz	
0	0	0	0	0	Normal 1	f _{CLK} /64	19 f _{AD} (number of sampling clock: 7 f _{AD})	1216/f _{CLK}	Setting prohibited	Setting prohibited	Setting prohibited	76 μs	38 μs	
0	0	1	f _{CLK} /32	608/f _{CLK}		76 μs		38 μs				19 μs		
0	1	0	f _{CLK} /16	304/f _{CLK}		76 μs		38 μs				19 μs	9.5 μs	
0	1	1	f _{CLK} /8	152/f _{CLK}		38 μs		19 μs				9.5 μs	4.75 μs	
1	0	0	f _{CLK} /6	114/f _{CLK}		28.5 μs		14.25 μs				7.125 μs	3.5625 μs	
1	0	1	f _{CLK} /5	95/f _{CLK}		95 μs		23.75 μs				11.875 μs	5.938 μs	2.9688 μs
1	1	0	f _{CLK} /4	76/f _{CLK}		76 μs		19 μs				9.5 μs	4.75 μs	2.375 μs
1	1	1	f _{CLK} /2	38/f _{CLK}		38 μs		9.5 μs				4.75 μs	2.375 μs	Setting prohibited
0	0	0	0	1	Normal 2	f _{CLK} /64	17 f _{AD} (number of sampling clock: 5 f _{AD})	1088/f _{CLK}	Setting prohibited	Setting prohibited	Setting prohibited	68 μs	34 μs	
0	0	1	f _{CLK} /32	544/f _{CLK}		68 μs		34 μs				17 μs		
0	1	0	f _{CLK} /16	272/f _{CLK}		68 μs		34 μs				17 μs	8.5 μs	
0	1	1	f _{CLK} /8	136/f _{CLK}		34 μs		17 μs				8.5 μs	4.25 μs	
1	0	0	f _{CLK} /6	102/f _{CLK}		25.5 μs		12.75 μs				6.375 μs	3.1875 μs	
1	0	1	f _{CLK} /5	85/f _{CLK}		85 μs		21.25 μs				10.625 μs	5.3125 μs	2.6563 μs
1	1	0	f _{CLK} /4	68/f _{CLK}		68 μs		17 μs				8.5 μs	4.25 μs	2.125 μs
1	1	1	f _{CLK} /2	34/f _{CLK}		34 μs		8.5 μs				4.25 μs	2.125 μs	Setting prohibited

Note These are the numbers of clock cycles when conversion is with 10-bit resolution. When eight-bit resolution is selected, the values are shorter by two cycles of the conversion clock (f_{AD}).

- Cautions 1.** The A/D conversion time must also be within the relevant range of conversion times (t_{CONV}) described in 29.6.1 A/D converter characteristics or 30.6.1 A/D converter characteristics.
- 2.** Rewrite the FR2 to FR0, LV1 and LV0 bits to other than the same data while conversion is stopped (ADCS = 0, ADCE = 0).
- 3.** The above conversion time does not include conversion state time. Conversion state time add in the first conversion. Select conversion time, taking clock frequency errors into consideration.

Remark f_{CLK}: CPU/peripheral hardware clock frequency

Table 11-3. A/D Conversion Time Selection (2/4)

(2) When there is no A/D power supply stabilization wait time
 Low-voltage mode 1, 2 (software trigger mode/hardware trigger no-wait mode)

A/D Converter Mode Register 0 (ADM0)					Mode	Conversion Clock (f _{AD})	Number of Conversion Clock ^{Note 4}	Conversion Time	Conversion Time at 10-Bit Resolution					
FR2	FR1	FR0	LV1	LV0					1.6 V ≤ V _{DD} ≤ 5.5 V		Note 1	Note 2	Note 3	
									f _{CLK} = 1 MHz	f _{CLK} = 4 MHz	f _{CLK} = 8 MHz	f _{CLK} = 16 MHz	f _{CLK} = 32 MHz	
0	0	0	1	0	Low voltage 1	f _{CLK} /64	19 f _{AD} (number of sampling clock: 7 f _{AD})	1216/f _{CLK}	Setting prohibited	Setting prohibited	Setting prohibited	76 μs	38 μs	
0	0	1	f _{CLK} /32	608/f _{CLK}		76 μs		38 μs				19 μs		
0	1	0	f _{CLK} /16	304/f _{CLK}		76 μs		38 μs				19 μs	9.5 μs	
0	1	1	f _{CLK} /8	152/f _{CLK}		38 μs		19 μs				9.5 μs	4.75 μs	
1	0	0	f _{CLK} /6	114/f _{CLK}		28.5 μs		14.25 μs				7.125 μs	3.5625 μs	
1	0	1	f _{CLK} /5	95/f _{CLK}		95 μs		23.75 μs				11.875 μs	5.938 μs	2.9688 μs
1	1	0	f _{CLK} /4	76/f _{CLK}		76 μs		19 μs				9.5 μs	4.75 μs	2.375 μs
1	1	1	f _{CLK} /2	38/f _{CLK}		38 μs		9.5 μs				4.75 μs	2.375 μs	Setting prohibited
0	0	0	1	1	Low voltage 2	f _{CLK} /64	17 f _{AD} (number of sampling clock: 5 f _{AD})	1088/f _{CLK}	Setting prohibited	Setting prohibited	Setting prohibited	68 μs	34 μs	
0	0	1	f _{CLK} /32	544/f _{CLK}		68 μs		34 μs				17 μs		
0	1	0	f _{CLK} /16	272/f _{CLK}		68 μs		34 μs				17 μs	8.5 μs	
0	1	1	f _{CLK} /8	136/f _{CLK}		34 μs		17 μs				8.5 μs	4.25 μs	
1	0	0	f _{CLK} /6	102/f _{CLK}		25.5 μs		12.75 μs				6.375 μs	3.1875 μs	
1	0	1	f _{CLK} /5	85/f _{CLK}		85 μs		21.25 μs				10.625 μs	5.3125 μs	2.6563 μs
1	1	0	f _{CLK} /4	68/f _{CLK}		68 μs		17 μs				8.5 μs	4.25 μs	2.125 μs
1	1	1	f _{CLK} /2	34/f _{CLK}		34 μs		8.5 μs				4.25 μs	2.125 μs	Setting prohibited

- Notes 1.** 1.8 V ≤ V_{DD} ≤ 5.5 V
 2. 2.4 V ≤ V_{DD} ≤ 5.5 V
 3. 2.7 V ≤ V_{DD} ≤ 5.5 V
 4. These are the numbers of clock cycles when conversion is with 10-bit resolution. When eight-bit resolution is selected, the values are shorter by two cycles of the conversion clock (f_{AD}).

- Cautions 1.** The A/D conversion time must also be within the relevant range of conversion times (t_{CONV}) described in 29.6.1 A/D converter characteristics or 30.6.1 A/D converter characteristics.
 2. Rewrite the FR2 to FR0, LV1 and LV0 bits to other than the same data while conversion is stopped (ADCS = 0, ADCE = 0).
 3. The above conversion time does not include conversion state time. Conversion state time add in the first conversion. Select conversion time, taking clock frequency errors into consideration.

Remark f_{CLK}: CPU/peripheral hardware clock frequency

Table 11-3. A/D Conversion Time Selection (3/4)

(3) When there is A/D power supply stabilization wait time
Normal mode 1, 2 (hardware trigger wait mode ^{Note 1})

A/D Converter Mode Register 0 (ADM0)					Mode	Conversion Clock (f _{AD})	Number of Stabilization Wait Clock	Number of Conversion Clock ^{Note 2}	Stabilization Wait Time+ Conversion Time	Stabilization Wait Time + Conversion Time at 10-Bit Resolution					
FR2	FR1	FR0	LV1	LV0						2.7 V ≤ V _{DD} ≤ 5.5 V					
										f _{CLK} = 1 MHz	f _{CLK} = 4 MHz	f _{CLK} = 8 MHz	f _{CLK} = 16 MHz	f _{CLK} = 32 MHz	
0	0	0	0	0	Normal 1	f _{CLK} /64	8 f _{AD}	19 f _{AD} (number of sampling clock: 7 f _{AD})	1728/f _{CLK}	Setting prohibited	Setting prohibited	Setting prohibited	108 μs	54 μs	
0	0	1	f _{CLK} /32	864/f _{CLK}		108 μs			54 μs				27 μs		
0	1	0	f _{CLK} /16	432/f _{CLK}		108 μs			54 μs				27 μs	13.5 μs	
0	1	1	f _{CLK} /8	216/f _{CLK}		54 μs			27 μs				13.5 μs	6.75 μs	
1	0	0	f _{CLK} /6	162/f _{CLK}		40.5 μs			20.25 μs				10.125 μs	5.0625 μs	
1	0	1	f _{CLK} /5	135/f _{CLK}		135 μs			33.75 μs				16.875 μs	8.4375 μs	4.21875 μs
1	1	0	f _{CLK} /4	108/f _{CLK}		108 μs			27 μs				13.5 μs	6.75 μs	3.375 μs
1	1	1	f _{CLK} /2	54/f _{CLK}		54 μs			13.5 μs				6.75 μs	3.375 μs	Setting prohibited
0	0	0	0	1	Normal 2	f _{CLK} /64	8 f _{AD}	17 f _{AD} (number of sampling clock: 5 f _{AD})	1600/f _{CLK}	Setting prohibited	Setting prohibited	Setting prohibited	100 μs	50 μs	
0	0	1	f _{CLK} /32	800/f _{CLK}		100 μs			50 μs				25 μs		
0	1	0	f _{CLK} /16	400/f _{CLK}		100 μs			50 μs				25 μs	12.5 μs	
0	1	1	f _{CLK} /8	200/f _{CLK}		50 μs			25 μs				12.5 μs	6.25 μs	
1	0	0	f _{CLK} /6	150/f _{CLK}		37.5 μs			18.75 μs				9.375 μs	4.6875 μs	
1	0	1	f _{CLK} /5	125/f _{CLK}		125 μs			31.25 μs				15.625 μs	7.8125 μs	3.90625 μs
1	1	0	f _{CLK} /4	100/f _{CLK}		100 μs			25 μs				12.5 μs	6.25 μs	3.125 μs
1	1	1	f _{CLK} /2	50/f _{CLK}		50 μs			12.5 μs				6.25 μs	3.125 μs	Setting prohibited

- Notes 1.** For the second and subsequent conversion in sequential conversion mode and for conversion of the channel specified by scan 1, 2, and 3 in scan mode, the conversion start time and stabilization wait time for A/D power supply do not occur after a hardware trigger is detected (see **Table 11-3 (1/4)**).
- 2.** These are the numbers of clock cycles when conversion is with 10-bit resolution. When eight-bit resolution is selected, the values are shorter by two cycles of the conversion clock (f_{AD}).

- Cautions 1.** The A/D conversion time must also be within the relevant range of conversion times (t_{CONV}) described in 29.6.1 A/D converter characteristics or 30.6.1 A/D converter characteristics. Note that the conversion time (t_{CONV}) does not include the A/D power supply stabilization wait time.
- 2.** Rewrite the FR2 to FR0, LV1 and LV0 bits to other than the same data while conversion is stopped (ADCS = 0, ADCE = 0).
- 3.** The above conversion time does not include conversion state time. Conversion state time add in the first conversion. Select conversion time, taking clock frequency errors into consideration.
- 4.** When hardware trigger wait mode, specify the conversion time, including the stabilization wait time from the hardware trigger detection.

Remark f_{CLK}: CPU/peripheral hardware clock frequency

Table 11-3. A/D Conversion Time Selection (4/4)

(4) When there is A/D power supply stabilization wait time
 Low-voltage mode 1, 2 (hardware trigger wait mode ^{Note 1})

A/D Converter Mode Register 0 (ADM0)					Mode	Conversion Clock (f _{AD})	Number of Stabilization Wait Clock	Number of Conversion Clock ^{Note 5}	Stabilization Wait Time + Conversion Time	Stabilization Wait Time + Conversion Time at 10-Bit Resolution					
FR2	FR1	FR0	LV1	LV0						1.6 V ≤ V _{DD} ≤ 5.5 V					
										f _{CLK} = 1 MHz	f _{CLK} = 4 MHz	f _{CLK} = 8 MHz	f _{CLK} = 16 MHz	f _{CLK} = 32 MHz	
0	0	0	1	0	Low voltage 1	f _{CLK} /64	2 f _{AD}	19 f _{AD} (number of sampling clock: 7 f _{AD})	1344/f _{CLK}	Setting prohibited	Setting prohibited	Setting prohibited	84 μs	42 μs	
0	0	1	f _{CLK} /32	672/f _{CLK}		84 μs			42 μs				21 μs		
0	1	0	f _{CLK} /16	336/f _{CLK}		84 μs			42 μs				21 μs	10.5 μs	
0	1	1	f _{CLK} /8	168/f _{CLK}		42 μs			21 μs				10.5 μs	5.25 μs	
1	0	0	f _{CLK} /6	126/f _{CLK}		31.5 μs			15.75 μs				7.875 μs	3.9375 μs	
1	0	1	f _{CLK} /5	105/f _{CLK}		105 μs			26.25 μs				13.125 μs	6.5625 μs	3.28125 μs
1	1	0	f _{CLK} /4	84/f _{CLK}		84 μs			21 μs				10.5 μs	5.25 μs	2.625 μs
1	1	1	f _{CLK} /2	42/f _{CLK}		42 μs			10.5 μs				5.25 μs	2.625 μs	Setting prohibited
0	0	0	1	1	Low voltage 2	f _{CLK} /64	2 f _{AD}	17 f _{AD} (number of sampling clock: 5 f _{AD})	1216/f _{CLK}	Setting prohibited	Setting prohibited	Setting prohibited	76 μs	38 μs	
0	0	1	f _{CLK} /32	608/f _{CLK}		76 μs			38 μs				19 μs		
0	1	0	f _{CLK} /16	304/f _{CLK}		76 μs			38 μs				19 μs	9.5 μs	
0	1	1	f _{CLK} /8	152/f _{CLK}		38 μs			19 μs				9.5 μs	4.75 μs	
1	0	0	f _{CLK} /6	114/f _{CLK}		28.5 μs			14.25 μs				7.125 μs	3.5625 μs	
1	0	1	f _{CLK} /5	95/f _{CLK}		96 μs			23.75 μs				11.88 μs	5.938 μs	2.9688 μs
1	1	0	f _{CLK} /4	76/f _{CLK}		76 μs			19 μs				9.5 μs	4.75 μs	2.375 μs
1	1	1	f _{CLK} /2	38/f _{CLK}		38 μs			9.5 μs				4.75 μs	2.375 μs	Setting prohibited

- Notes 1.** For the second and subsequent conversion in sequential conversion mode and for conversion of the channel specified by scan 1, 2, and 3 in scan mode, the conversion start time and stabilization wait time for A/D power supply do not occur after a hardware trigger is detected (see **Table 11-3 (2/4)**).
- 1.8 V ≤ V_{DD} ≤ 5.5 V
 - 2.4 V ≤ V_{DD} ≤ 5.5 V
 - 2.7 V ≤ V_{DD} ≤ 5.5 V
 - These are the numbers of clock cycles when conversion is with 10-bit resolution. When eight-bit resolution is selected, the values are shorter by two cycles of the conversion clock (f_{AD}).

- Cautions 1.** The A/D conversion time must also be within the relevant range of conversion times (t_{CONV}) described in 29.6.1 A/D converter characteristics or 30.6.1 A/D converter characteristics. Note that the conversion time (t_{CONV}) does not include the A/D power supply stabilization wait time.
- Rewrite the FR2 to FR0, LV1 and LV0 bits to other than the same data while conversion is stopped (ADCS = 0, ADCE = 0).
 - The above conversion time does not include conversion state time. Conversion state time add in the first conversion. Select conversion time, taking clock frequency errors into consideration.
 - When hardware trigger wait mode, specify the conversion time, including the stabilization wait time from the hardware trigger detection.

Remark f_{CLK}: CPU/peripheral hardware clock frequency

Figure 11-5. A/D Converter Sampling and A/D Conversion Timing (Example for Software Trigger Mode)

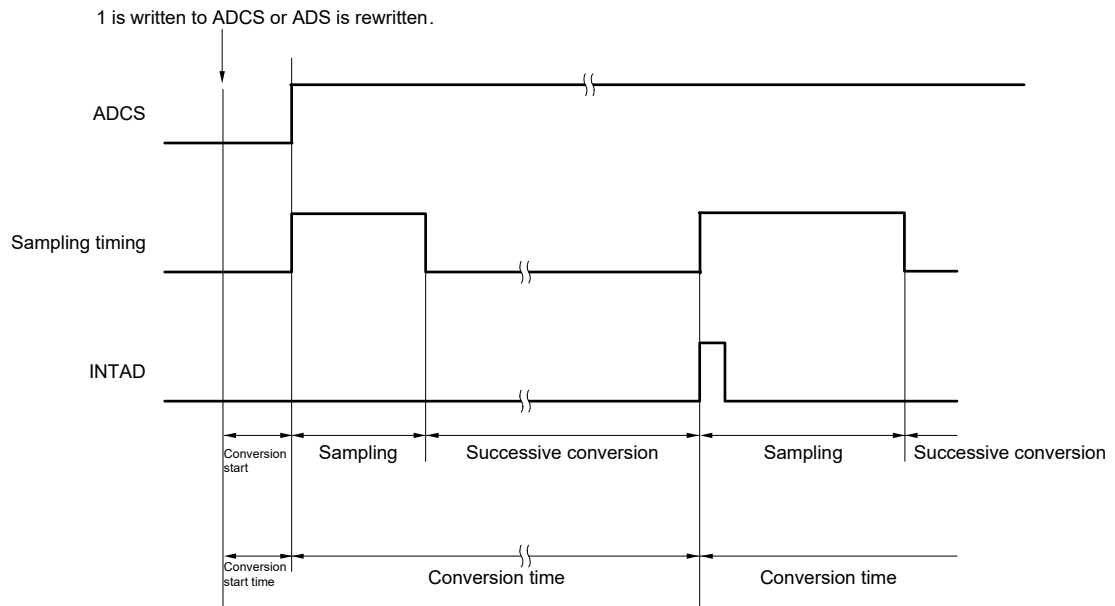

11.3.3 A/D converter mode register 1 (ADM1)

This register is used to specify the A/D conversion trigger, conversion mode, and hardware trigger signal.

The ADM1 register can be set by a 1-bit or 8-bit memory manipulation instruction.

Reset signal generation clears this register to 00H.

Figure 11-6. Format of A/D Converter Mode Register 1 (ADM1)

Address: FFF32H After reset: 00H R/W

Symbol	7	6	5	4	3	2	1	0
ADM1	ADTMD1	ADTMD0	ADSCM	0	0	0	ADTRS1	ADTRS0

ADTMD1	ADTMD0	Selection of the A/D conversion trigger mode
0	×	Software trigger mode
1	0	Hardware trigger no-wait mode
1	1	Hardware trigger wait mode

ADSCM	Specification of the A/D conversion mode
0	Sequential conversion mode
1	One-shot conversion mode

ADTRS1	ADTRS0	Selection of the hardware trigger signal
0	0	End of timer channel 01 count or capture interrupt signal (INTTM01)
0	1	Setting prohibited
1	0	Real-time clock interrupt signal (INTRTC)
1	1	12-bit interval timer interrupt signal (INTIT)

- Cautions**
1. Rewrite the value of the ADM1 register while conversion is stopped (ADCS = 0, ADCE = 0).
 2. To complete A/D conversion, specify at least the following time as the hardware trigger interval:
Hardware trigger no wait mode: 2 f_{CLK} clock + conversion start time + A/D conversion time
Hardware trigger wait mode: 2 f_{CLK} clock + conversion start time + A/D power supply stabilization wait time + A/D conversion time
 3. In modes other than SNOOZE mode, input of the next INTRTC or INTIT will not be recognized as a valid hardware trigger for up to four f_{CLK} cycles after the first INTRTC or INTIT is input.

- Remarks**
1. ×: don't care
 2. f_{CLK}: CPU/peripheral hardware clock frequency

11.3.4 A/D converter mode register 2 (ADM2)

This register is used to select the + side or - side reference voltage of the A/D converter, check the upper limit and lower limit A/D conversion result values, select the resolution, and specify whether to use the SNOOZE mode.

The ADM2 register can be set by a 1-bit or 8-bit memory manipulation instruction.

Reset signal generation clears this register to 00H.

Figure 11-7. Format of A/D Converter Mode Register 2 (ADM2) (1/2)

Address: F0010H After reset: 00H R/W

Symbol	7	6	5	4	<3>	<2>	1	<0>
ADM2	ADREFP1	ADREFP0	ADREFM	0	ADRCK	AWC	0	ADTYP

ADREFP1	ADREFP0	Selection of the + side reference voltage source of the A/D converter
0	0	Supplied from V _{DD}
0	1	Supplied from P20/AV _{REFP} /ANI0
1	0	Supplied from the internal reference voltage (1.45 V) Note
1	1	Setting prohibited

- When ADREFP1 or ADREFP0 bit is rewritten, this must be configured in accordance with the following procedures.
 - Set ADCE = 0
 - Change the values of ADREFP1 and ADREFP0
 - Reference voltage stabilization wait time
 - Set ADCE = 1
 - Reference voltage stabilization wait time
 When ADREFP1 and ADREFP0 are set to 1 and 0, the setting is changed to A = 5 μs, B = 1 μs.
 When ADREFP1 and ADREFP0 are set to 0 and 0 or 0 and 1, A needs no wait and B = 1 μs.
 After (5) stabilization time, start the A/D conversion.
- When ADREFP1 and ADREFP0 are set to 1 and 0, respectively, A/D conversion cannot be performed on the temperature sensor output voltage and internal reference voltage (1.45 V).
 Be sure to perform A/D conversion while ADISS = 0.

ADREFM	Selection of the – side reference voltage of the A/D converter
0	Supplied from V _{SS}
1	Supplied from P21/AV _{REFM} /ANI1

Note This setting can be used only in HS (high-speed main) mode.

- Cautions**
1. Rewrite the value of the ADM2 register while conversion is stopped (ADCS = 0, ADCE = 0).
 2. Do not set the ADREFP1 bit to 1 when shifting to STOP mode, or to HALT mode while the CPU is operating on the subsystem clock. When the internal reference voltage is selected (ADREFP1, ADREFP0 = 1, 0), the A/D converter reference voltage current (I_{ADREF}) indicated in 29.4.2 Supply current characteristics or 30.4.2 Supply current characteristics will be added.
 3. When using AV_{REFP} and AV_{REFM}, specify ANI0 and ANI1 as the analog input channels and specify input mode by using the port mode register.

Figure 11-7. Format of A/D Converter Mode Register 2 (ADM2) (2/2)

Address: F0010H After reset: 00H R/W

Symbol	7	6	5	4	<3>	<2>	1	<0>
ADM2	ADREFP1	ADREFP0	ADREFM	0	ADRCK	AWC	0	ADTYP

ADRCK	Checking the upper limit and lower limit conversion result values
0	The interrupt signal (INTAD) is output when the ADLL register \leq the ADCR register \leq the ADUL register (AREA 1).
1	The interrupt signal (INTAD) is output when the ADCR register $<$ the ADLL register (AREA 2) or the ADUL register $<$ the ADCR register (AREA 3).
Figure 11-8 shows the generation range of the interrupt signal (INTAD) for AREA 1 to AREA 3.	

AWC	Specification of the SNOOZE mode
0	Do not use the SNOOZE mode function.
1	Use the SNOOZE mode function.
<p>When there is a hardware trigger signal in the STOP mode, the STOP mode is exited, and A/D conversion is performed without operating the CPU (the SNOOZE mode).</p> <ul style="list-style-type: none"> The SNOOZE mode function can only be specified when the high-speed on-chip oscillator clock is selected for the CPU/peripheral hardware clock (f_{CLK}). If any other clock is selected, specifying this mode is prohibited. Using the SNOOZE mode function in the software trigger mode or hardware trigger no-wait mode is prohibited. Using the SNOOZE mode function in the sequential conversion mode is prohibited. When using the SNOOZE mode function, specify a hardware trigger interval of at least "shift time to SNOOZE mode + conversion start time + A/D power supply stabilization wait time + A/D conversion time + 2 f_{CLK} clock" Even when using SNOOZE mode, be sure to set the AWC bit to 0 in normal operation and change it to 1 just before shifting to STOP mode. <p>Also, be sure to change the AWC bit to 0 after returning from STOP mode to normal operation. If the AWC bit is left set to 1, A/D conversion will not start normally in spite of the subsequent SNOOZE mode or normal operation.</p>	

ADTYP	Selection of the A/D conversion resolution
0	10-bit resolution
1	8-bit resolution

Note Refer to "Transition time from STOP mode to SNOOZE mode" in 18.3.3 SNOOZE mode.

Caution Only rewrite the value of the ADM2 register while conversion operation is stopped (ADCS = 0, ADCE = 0).

Figure 11-8. ADRCK Bit Interrupt Signal Generation Range

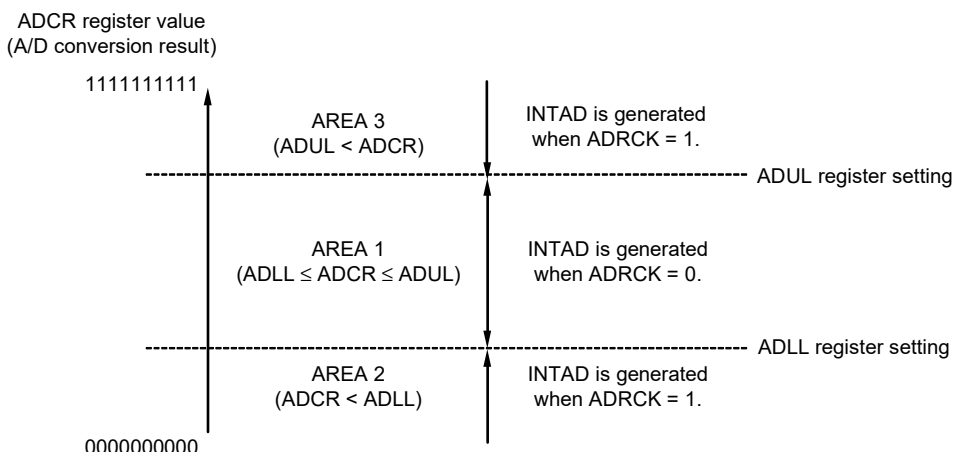

Remark If INTAD does not occur, the A/D conversion result is not stored in the ADCR or ADCRH register.

11.3.5 10-bit A/D conversion result register (ADCR)

This register is a 16-bit register that stores the A/D conversion result. The lower 6 bits are fixed to 0. Each time A/D conversion ends, the conversion result is loaded from the successive approximation register (SAR). The higher 8 bits of the conversion result are stored in FFF1FH and the lower 2 bits are stored in the higher 2 bits of FFF1EH ^{Note}.

The ADCR register can be read by a 16-bit memory manipulation instruction.
Reset signal generation clears this register to 0000H.

Note If the A/D conversion result is outside the range specified by using the A/D conversion comparison function (the value specified by the ADRCK bit of the ADM2 register and ADUL/ADLL registers; see **Figure 11-8**), the result is not stored.

Figure 11-9. Format of 10-bit A/D Conversion Result Register (ADCR)

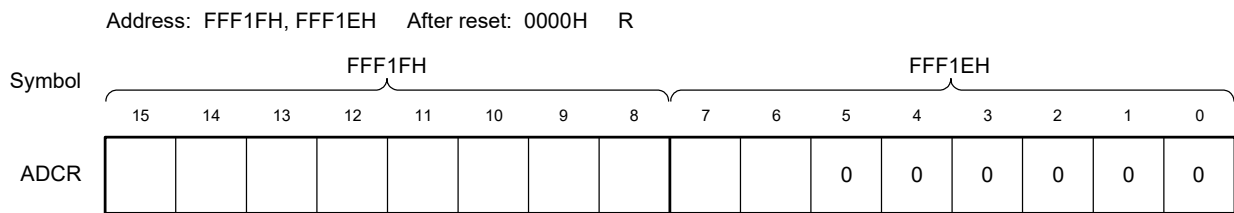

- Cautions**
1. When 8-bit resolution A/D conversion is selected (when the ADTYP bit of A/D converter mode register 2 (ADM2) is 1) and the ADCR register is read, 0 is read from the lower two bits (bits 7 and 6 of the ADCR register).
 2. When the ADCR register is accessed in 16-bit units, the higher 10 bits of the conversion result are read in order starting at bit 15 of the ADCR register.

11.3.6 8-bit A/D conversion result register (ADCRH)

This register is an 8-bit register that stores the A/D conversion result. The higher 8 bits of 10-bit resolution are stored **Note**.

The ADCRH register can be read by an 8-bit memory manipulation instruction.

Reset signal generation clears this register to 00H.

Note If the A/D conversion result is outside the range specified by using the A/D conversion comparison function (the value specified by the ADRCK bit of the ADM2 register and ADUL/ADLL registers; see **Figure 11-8**), the result is not stored.

Figure 11-10. Format of 8-bit A/D Conversion Result Register (ADCRH)

Address: FFF1FH After reset: 00H R

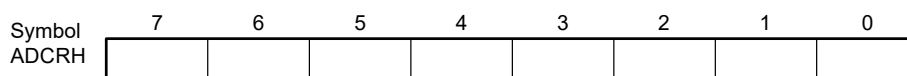

Caution When writing to the A/D converter mode register 0 (ADM0), analog input channel specification register (ADS), and A/D port configuration register (ADPC), the contents of the ADCRH register may become undefined. Read the conversion result following conversion completion before writing to the ADM0, ADS, and ADPC registers. Using timing other than the above may cause an incorrect conversion result to be read.

11.3.7 Analog input channel specification register (ADS)

This register specifies the input channel of the analog voltage to be A/D converted.
 The ADS register can be set by a 1-bit or 8-bit memory manipulation instruction.
 Reset signal generation clears this register to 00H.

Figure 11-11. Format of Analog Input Channel Specification Register (ADS) (1/2)

Address: FFF31H After reset: 00H R/W

Symbol	7	6	5	4	3	2	1	0
ADS	ADISS	0	0	ADS4	ADS3	ADS2	ADS1	ADS0

0 Select mode (ADMD = 0)

ADISS	ADS4	ADS3	ADS2	ADS1	ADS0	Analog input channel	Input source
0	0	0	0	0	0	ANI0	P20/ANI0/AV _{REFP} pin
0	0	0	0	0	1	ANI1	P21/ANI1/AV _{REFM} pin
0	0	0	0	1	0	ANI2	P22/ANI2 pin
0	0	0	0	1	1	ANI3	P23/ANI3 pin
0	0	0	1	0	0	ANI4	P24/ANI4 pin
0	0	0	1	0	1	ANI5	P25/ANI5 pin
0	0	0	1	1	0	ANI6	P26/ANI6 pin
0	0	0	1	1	1	ANI7	P27/ANI7 pin
0	0	1	0	0	0	ANI8	P150/ANI8 pin
0	0	1	0	0	1	ANI9	P151/ANI9 pin
0	0	1	0	1	0	ANI10	P152/ANI10 pin
0	0	1	0	1	1	ANI11	P153/ANI11 pin
0	0	1	1	0	0	ANI12	P154/ANI12 pin
0	0	1	1	0	1	ANI13	P155/ANI13 pin
0	0	1	1	1	0	ANI14	P156/ANI14 pin
0	0	1	1	1	1	Setting prohibited	
0	1	0	0	0	0	ANI16	P03/ANI16 pin ^{Note 1}
0	1	0	0	0	1	ANI17	P02/ANI17 pin ^{Note 2}
0	1	0	0	1	0	ANI18	P147/ANI18 pin
0	1	0	0	1	1	ANI19	P120/ANI19 pin
0	1	0	1	0	0	ANI20	P100/ANI20 pin
0	1	0	1	0	1	ANI21	P37/ANI21 pin
0	1	0	1	1	0	ANI22	P36/ANI22 pin
0	1	0	1	1	1	ANI23	P35/ANI23 pin
0	1	1	0	0	0	ANI24	P117/ANI24 pin
0	1	1	0	0	1	ANI25	P116/ANI25 pin
0	1	1	0	1	0	ANI26	P115/ANI26 pin
0	1	1	0	1	1	Setting prohibited	
1	0	0	0	0	0	–	Temperature sensor output voltage ^{Note 3}
1	0	0	0	0	1	–	Internal reference voltage (1.45 V) ^{Note 3}
Other than the above						Setting prohibited	

(Cautions are given below Figure 11-11 Format of Analog Input Channel Specification Register (ADS) (2/2).)

- Notes 1. 20-, 24-, 25-, 30-, 32-pin products: P01/ANI16 pin
- 2. 20-, 24-, 25-, 30-, 32-pin products: P00/ANI17 pin
- 3. This setting can be used only in HS (high-speed main) mode.

Figure 11-11. Format of Analog Input Channel Specification Register (ADS) (2/2)

Address: FFF31H After reset: 00H R/W

Symbol	7	6	5	4	3	2	1	0
ADS	ADISS	0	0	ADS4	ADS3	ADS2	ADS1	ADS0

0 Scan mode (ADMD = 1)

ADISS	ADS4	ADS3	ADS2	ADS1	ADS0	Analog input channel			
						Scan 0	Scan 1	Scan 2	Scan 3
0	0	0	0	0	0	ANI0	ANI1	ANI2	ANI3
0	0	0	0	0	1	ANI1	ANI2	ANI3	ANI4
0	0	0	0	1	0	ANI2	ANI3	ANI4	ANI5
0	0	0	0	1	1	ANI3	ANI4	ANI5	ANI6
0	0	0	1	0	0	ANI4	ANI5	ANI6	ANI7
0	0	0	1	0	1	ANI5	ANI6	ANI7	ANI8
0	0	0	1	1	0	ANI6	ANI7	ANI8	ANI9
0	0	0	1	1	1	ANI7	ANI8	ANI9	ANI10
0	0	1	0	0	0	ANI8	ANI9	ANI10	ANI11
0	0	1	0	0	1	ANI9	ANI10	ANI11	ANI12
0	0	1	0	1	0	ANI10	ANI11	ANI12	ANI13
0	0	1	0	1	1	ANI11	ANI12	ANI13	ANI14
Other than the above						Setting prohibited			

- Cautions**
1. Be sure to clear bits 5 and 6 to 0.
 2. Set a channel to be set the analog input by ADPC and PMCx registers in the input mode by using port mode registers 0, 2, 3, 10 to 12, 14, or 15 (PM0, PM2, PM3, PM10 to PM12, PM14, PM15).
 3. Do not set the pin that is set by the A/D port configuration register (ADPC) as digital I/O by the ADS register.
 4. Do not set the pin that is set by port mode control register 0, 3, 10 to 12, or 14 (PMC0, PMC3, PMC10 to PMC12, PMC14) as digital I/O by the ADS register.
 5. Rewrite the value of the ADISS bit while conversion is stopped (ADCS = 0, ADCE = 0).
 6. If using AVREFP as the + side reference voltage of the A/D converter, do not select ANI0 as an A/D conversion channel.
 7. If using AVREFM as the - side reference voltage of the A/D converter, do not select ANI1 as an A/D conversion channel.
 8. If the ADISS bit is set to 1, the internal reference voltage (1.45 V) cannot be used for the + side reference voltage. After the ADISS bit is set to 1, the initial conversion result cannot be used. For the setting flow, see 11.7.4 Setup when temperature sensor output voltage/internal reference voltage is selected (example for software trigger mode and one-shot conversion mode).
 9. Do not set the ADISS bit to 1 when shifting to STOP mode, or to HALT mode while the CPU is operating on the subsystem clock. When the ADISS bit is set to 1, the A/D converter reference voltage current (IADREF) indicated in 29.3.2 Supply current characteristics or 30.3.2 Supply current characteristics will be added.

11.3.8 Conversion result comparison upper limit setting register (ADUL)

This register is used to specify the setting for checking the upper limit of the A/D conversion results.

The A/D conversion results and ADUL register value are compared, and interrupt signal (INTAD) generation is controlled in the range specified for the ADRCK bit of A/D converter mode register 2 (ADM2) (shown in **Figure 11-8**).

The ADUL register can be set by an 8-bit memory manipulation instruction.

Reset signal generation sets this register to FFH.

Figure 11-12. Format of Conversion Result Comparison Upper Limit Setting Register (ADUL)

Address: F0011H After reset: FFH R/W

Symbol	7	6	5	4	3	2	1	0
ADUL	ADUL7	ADUL6	ADUL5	ADUL4	ADUL3	ADUL2	ADUL1	ADUL0

11.3.9 Conversion result comparison lower limit setting register (ADLL)

This register is used to specify the setting for checking the lower limit of the A/D conversion results.

The A/D conversion results and ADLL register value are compared, and interrupt signal (INTAD) generation is controlled in the range specified for the ADRCK bit of A/D converter mode register 2 (ADM2) (shown in **Figure 11-8**).

The ADLL register can be set by an 8-bit memory manipulation instruction.

Reset signal generation clears this register to 00H.

Figure 11-13. Format of Conversion Result Comparison Lower Limit Setting Register (ADLL)

Address: F0012H After reset: 00H R/W

Symbol	7	6	5	4	3	2	1	0
ADLL	ADLL7	ADLL6	ADLL5	ADLL4	ADLL3	ADLL2	ADLL1	ADLL0

- Cautions**
1. When A/D conversion with 10-bit resolution is selected, the eight higher-order bits of the 10-bit A/D conversion result register (ADCR) are compared with the values in the ADUL and ADLL registers.
 2. Only write new values to the ADUL and ADLL registers while conversion is stopped (ADCS = 0, ADCE = 0).
 3. The setting of the ADUL registers must be greater than that of the ADLL register.

11.3.10 A/D test register (ADTES)

This register is used to select the + side reference voltage or - side reference voltage for the converter, an analog input channel (ANlxx), the temperature sensor output voltage, or the internal reference voltage (1.45 V) as the target for A/D conversion.

When using this register to test the converter, set as follows.

- For zero-scale measurement, select the - side reference voltage as the target for conversion.
- For full-scale measurement, select the + side reference voltage as the target for conversion.

The ADTES register can be set by an 8-bit memory manipulation instruction.

Reset signal generation clears this register to 00H.

Figure 11-14. Format of A/D Test Register (ADTES)

Address: F0013H After reset: 00H R/W

Symbol	7	6	5	4	3	2	1	0
ADTES	0	0	0	0	0	0	ADTES1	ADTES0

ADTES1	ADTES0	A/D conversion target
0	0	ANlxx/temperature sensor output voltage ^{Note} /internal reference voltage (1.45 V) ^{Note} (This is specified using the analog input channel specification register (ADS).)
1	0	The - side reference voltage (selected by the ADREFM bit of the ADM2 register)
1	1	The + side reference voltage (selected by the ADREFP1 or ADREFP0 bit of the ADM2 register)
Other than the above		Setting prohibited

Note The temperature sensor output voltage and internal reference voltage (1.45 V) can be selected only in the HS (high-speed main) mode.

11.3.11 Registers controlling port function of analog input pins

Set up the registers for controlling the functions of the ports shared with the analog input pins of the A/D converter (port mode registers (PMxx), port mode control registers (PMCxx), and A/D port configuration register (ADPC)). For details, see **4.3.1 Port mode registers (PMxx)**, **4.3.6 Port mode control registers (PMCxx)**, and **4.3.7 A/D port configuration register (ADPC)**.

When using the ANI0 to ANI14 pins for analog input of the A/D converter, set the port mode register (PMxx) bit corresponding to each port to 1 and select analog input through the A/D port configuration register (ADPC).

When using the ANI16 to ANI26 pins for analog input of the A/D converter, set the port mode register (PMxx) bit and port mode control register (PMCxx) bit corresponding to each port to 1.

11.4 A/D Converter Conversion Operations

The A/D converter conversion operations are described below.

- <1> The voltage input to the selected analog input channel is sampled by the sample & hold circuit.
- <2> When sampling has been done for a certain time, the sample & hold circuit is placed in the hold state and the sampled voltage is held until the A/D conversion operation has ended.
- <3> Bit 9 of the successive approximation register (SAR) is set. The series resistor string voltage tap is set to $(1/2) AV_{REF}$ by the tap selector.
- <4> The voltage difference between the series resistor string voltage tap and sampled voltage is compared by the voltage comparator. If the analog input is greater than $(1/2) AV_{REF}$, the MSB bit of the SAR register remains set to 1. If the analog input is smaller than $(1/2) AV_{REF}$, the MSB bit is reset to 0.
- <5> Next, bit 8 of the SAR register is automatically set to 1, and the operation proceeds to the next comparison. The series resistor string voltage tap is selected according to the preset value of bit 9, as described below.
 - Bit 9 = 1: $(3/4) AV_{REF}$
 - Bit 9 = 0: $(1/4) AV_{REF}$
 The voltage tap and sampled voltage are compared and bit 8 of the SAR register is manipulated as follows.
 - Sampled voltage \geq Voltage tap: Bit 8 = 1
 - Sampled voltage $<$ Voltage tap: Bit 8 = 0
- <6> Comparison is continued in this way up to bit 0 of the SAR register.
- <7> Upon completion of the comparison of 10 bits, an effective digital result value remains in the SAR register, and the result value is transferred to the A/D conversion result register (ADCR, ADCRH) and then latched ^{Note 1}. At the same time, the A/D conversion end interrupt request (INTAD) can also be generated ^{Note 1}.
- <8> Repeat steps <1> to <7>, until the ADCS bit is cleared to 0 ^{Note 2}.
To stop the A/D converter, clear the ADCS bit to 0.

- Notes**
1. If the A/D conversion result is outside the A/D conversion result range specified by the ADRCK bit and the ADUL and ADLL registers (see **Figure 11-8**), the A/D conversion result interrupt request signal is not generated and no A/D conversion results are stored in the ADCR and ADCRH registers.
 2. While in the sequential conversion mode, the ADCS flag is not automatically cleared to 0. This flag is not automatically cleared to 0 while in the one-shot conversion mode of the hardware trigger no-wait mode, either. Instead, 1 is retained.

- Remarks**
1. Two types of the A/D conversion result registers are available.
 - ADCR register (16 bits): Store 10-bit A/D conversion value
 - ADCRH register (8 bits): Store 8-bit A/D conversion value
 2. AV_{REF} : The + side reference voltage of the A/D converter. This can be selected from AV_{REFP} , the internal reference voltage (1.45 V), and V_{DD} .

Figure 11-15. Conversion Operation of A/D Converter (Software Trigger Mode)

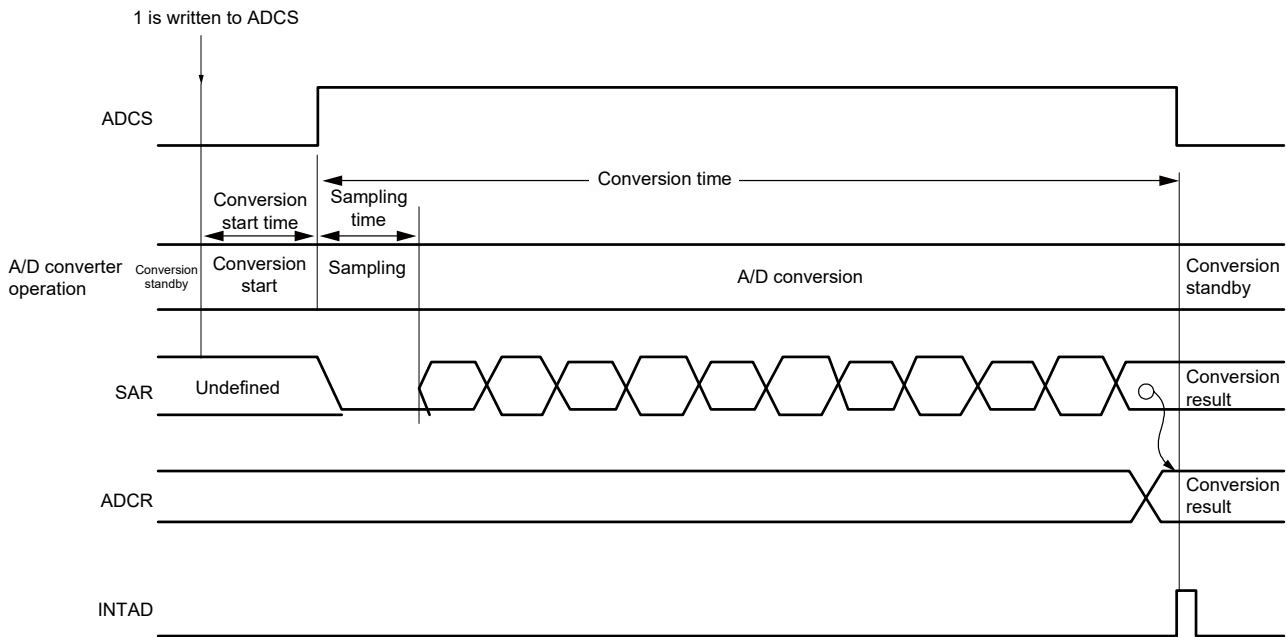

In one-shot conversion mode, the ADCS bit is automatically cleared to 0 after completion of A/D conversion.

In sequential conversion mode, A/D conversion operations proceed continuously until the software clears bit 7 (ADCS) of the A/D converter mode register 0 (ADM0) to 0.

Writing to the analog input channel specification register (ADS) during A/D conversion interrupts the current conversion after which A/D conversion of the analog input specified by the ADS register proceeds. Data from the A/D conversion that was in progress are discarded.

Reset signal generation clears the A/D conversion result register (ADCR, ADCRH) to 0000H or 00H.

11.5 Input Voltage and Conversion Results

The relationship between the analog input voltage input to the analog input pins (ANI0 to ANI14, ANI16 to ANI26) and the theoretical A/D conversion result (stored in the 10-bit A/D conversion result register (ADCR)) is shown by the following expression.

$$SAR = \text{INT} \left(\frac{V_{AIN}}{AV_{REF}} \times 1024 + 0.5 \right)$$

$$ADCR = SAR \times 64$$

or

$$\left(\frac{ADCR}{64} - 0.5 \right) \times \frac{AV_{REF}}{1024} \leq V_{AIN} < \left(\frac{ADCR}{64} + 0.5 \right) \times \frac{AV_{REF}}{1024}$$

where, INT(): Function which returns integer part of value in parentheses

V_{AIN}: Analog input voltage

AV_{REF}: AV_{REF} pin voltage

ADCR: A/D conversion result register (ADCR) value

SAR: Successive approximation register

Figure 11-16 shows the relationship between the analog input voltage and the A/D conversion result.

Figure 11-16. Relationship Between Analog Input Voltage and A/D Conversion Result

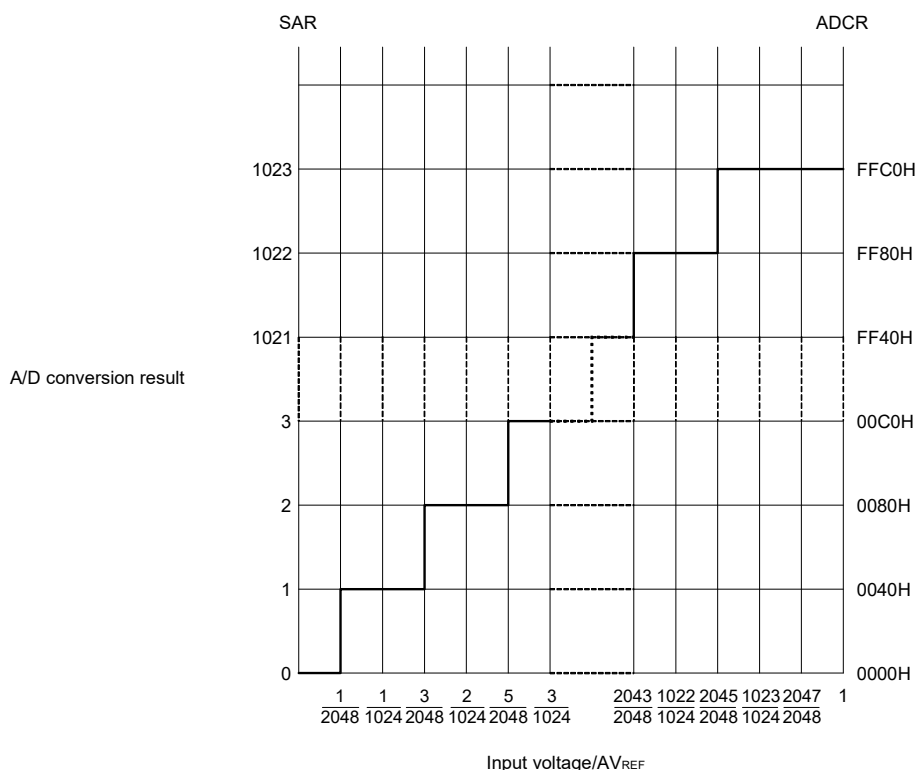

Remark AV_{REF}: The + side reference voltage of the A/D converter. This can be selected from AV_{REFP}, the internal reference voltage (1.45 V), and V_{DD}.

11.6 A/D Converter Operation Modes

The operation of each A/D converter mode is described below. In addition, the procedure for specifying each mode is described in 11.7 A/D Converter Setup Flowchart.

11.6.1 Software trigger mode (select mode, sequential conversion mode)

- <1> In the stop status, the ADCE bit of A/D converter mode register 0 (ADM0) is set to 1, and the system enters the A/D conversion standby status.
- <2> After the software counts up to the stabilization wait time (1 μ s), the ADCS bit of the ADM0 register is set to 1 to perform the A/D conversion of the analog input specified by the analog input channel specification register (ADS).
- <3> When A/D conversion ends, the conversion result is stored in the A/D conversion result register (ADCR, ADCRH), and the A/D conversion end interrupt request signal (INTAD) is generated. After A/D conversion ends, the next A/D conversion immediately starts.
- <4> When ADCS is overwritten with 1 during conversion operation, the current A/D conversion is interrupted, and conversion restarts. The partially converted data is discarded.
- <5> When the value of the ADS register is rewritten or overwritten during conversion operation, the current A/D conversion is interrupted, and A/D conversion is performed on the analog input respecified by the ADS register. The partially converted data is discarded.
- <6> Even if a hardware trigger is input during conversion operation, A/D conversion does not start.
- <7> When ADCS is cleared to 0 during conversion operation, the current A/D conversion is interrupted, and the system enters the A/D conversion standby status.
- <8> When ADCE is cleared to 0 while in the A/D conversion standby status, the A/D converter enters the stop status. When ADCE = 0, specifying 1 for ADCS is ignored and A/D conversion does not start.

Figure 11-17. Example of Software Trigger Mode (Select Mode, Sequential Conversion Mode) Operation Timing

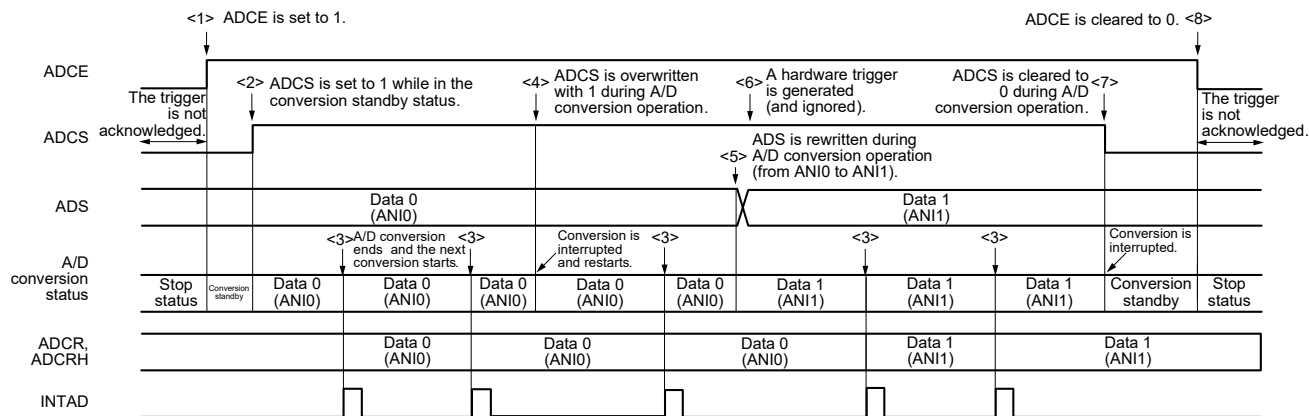

11.6.2 Software trigger mode (select mode, one-shot conversion mode)

- <1> In the stop status, the ADCE bit of A/D converter mode register 0 (ADM0) is set to 1, and the system enters the A/D conversion standby status.
- <2> After the software counts up to the stabilization wait time (1 μs), the ADCS bit of the ADM0 register is set to 1 to perform the A/D conversion of the analog input specified by the analog input channel specification register (ADS).
- <3> When A/D conversion ends, the conversion result is stored in the A/D conversion result register (ADCR, ADCRH), and the A/D conversion end interrupt request signal (INTAD) is generated.
- <4> After A/D conversion ends, the ADCS bit is automatically cleared to 0, and the system enters the A/D conversion standby status.
- <5> When ADCS is overwritten with 1 during conversion operation, the current A/D conversion is interrupted, and conversion restarts. The partially converted data is discarded.
- <6> When the value of the ADS register is rewritten or overwritten during conversion operation, the current A/D conversion is interrupted, and A/D conversion is performed on the analog input respecified by the ADS register. The partially converted data is discarded.
- <7> When ADCS is cleared to 0 during conversion operation, the current A/D conversion is interrupted, and the system enters the A/D conversion standby status.
- <8> When ADCE is cleared to 0 while in the A/D conversion standby status, the A/D converter enters the stop status. When ADCE = 0, specifying 1 for ADCS is ignored and A/D conversion does not start. In addition, A/D conversion does not start even if a hardware trigger is input while in the A/D conversion standby status.

Figure 11-18. Example of Software Trigger Mode (Select Mode, One-Shot Conversion Mode) Operation Timing

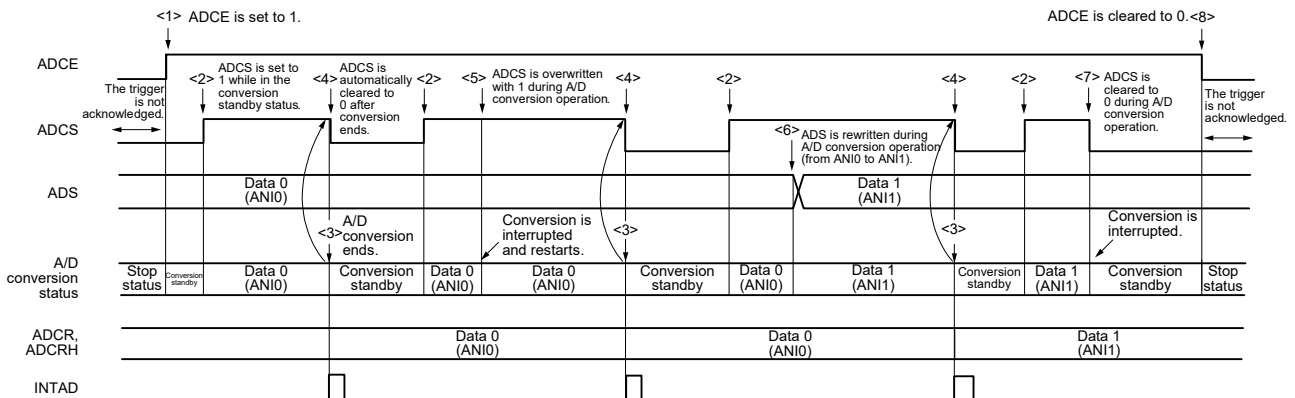

11.6.3 Software trigger mode (scan mode, sequential conversion mode)

- <1> In the stop status, the ADCE bit of A/D converter mode register 0 (ADM0) is set to 1, and the system enters the A/D conversion standby status.
- <2> After the software counts up to the stabilization wait time (1 μ s), the ADCS bit of the ADM0 register is set to 1 to perform A/D conversion on the four analog input channels specified by scan 0 to scan 3, which are specified by the analog input channel specification register (ADS). A/D conversion is performed on the analog input channels in order, starting with that specified by scan 0.
- <3> A/D conversion is sequentially performed on the four analog input channels, the conversion results are stored in the A/D conversion result register (ADCR, ADCRH) each time conversion ends, and the A/D conversion end interrupt request signal (INTAD) is generated. After A/D conversion of the four channels ends, the A/D conversion of the channel following the specified channel automatically starts (until all four channels are finished).
- <4> When ADCS is overwritten with 1 during conversion operation, the current A/D conversion is interrupted, and conversion restarts at the first channel. The partially converted data is discarded.
- <5> When the value of the ADS register is rewritten or overwritten during conversion operation, the current A/D conversion is interrupted, and A/D conversion is performed on the first channel respecified by the ADS register. The partially converted data is discarded.
- <6> Even if a hardware trigger is input during conversion operation, A/D conversion does not start.
- <7> When ADCS is cleared to 0 during conversion operation, the current A/D conversion is interrupted, and the system enters the A/D conversion standby status.
- <8> When ADCE is cleared to 0 while in the A/D conversion standby status, the A/D converter enters the stop status. When ADCE = 0, specifying 1 for ADCS is ignored and A/D conversion does not start.

Figure 11-19. Example of Software Trigger Mode (Scan Mode, Sequential Conversion Mode) Operation Timing

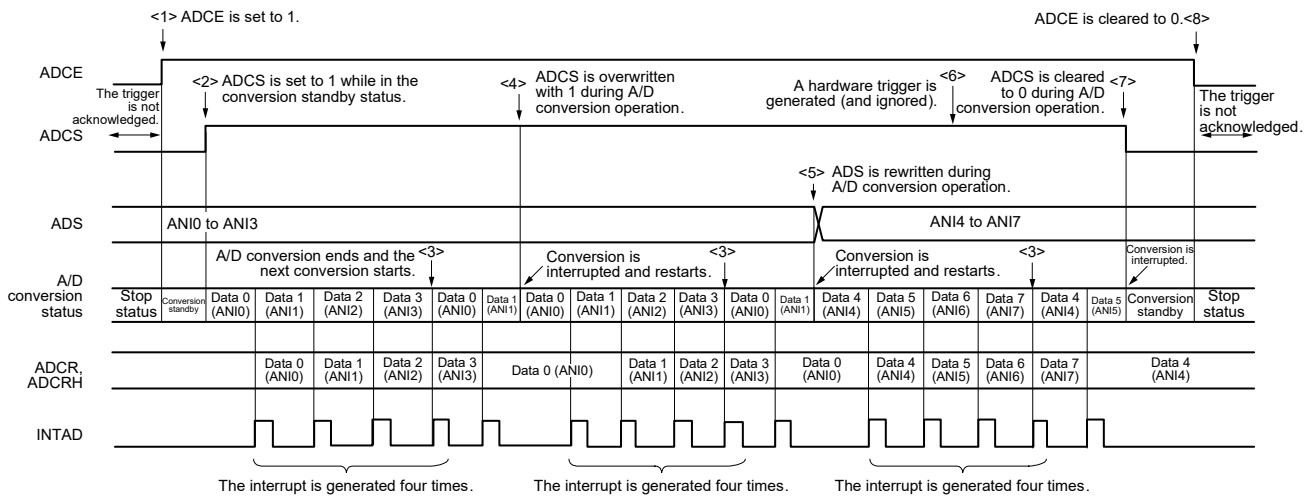

11.6.4 Software trigger mode (scan mode, one-shot conversion mode)

- <1> In the stop status, the ADCE bit of A/D converter mode register 0 (ADM0) is set to 1, and the system enters the A/D conversion standby status.
- <2> After the software counts up to the stabilization wait time (1 μs), the ADCS bit of the ADM0 register is set to 1 to perform A/D conversion on the four analog input channels specified by scan 0 to scan 3, which are specified by the analog input channel specification register (ADS). A/D conversion is performed on the analog input channels in order, starting with that specified by scan 0.
- <3> A/D conversion is sequentially performed on the four analog input channels, the conversion results are stored in the A/D conversion result register (ADCR, ADCRH) each time conversion ends, and the A/D conversion end interrupt request signal (INTAD) is generated.
- <4> After A/D conversion of the four channels ends, the ADCS bit is automatically cleared to 0, and the system enters the A/D conversion standby status.
- <5> When ADCS is overwritten with 1 during conversion operation, the current A/D conversion is interrupted, and conversion restarts at the first channel. The partially converted data is discarded.
- <6> When the value of the ADS register is rewritten or overwritten during conversion operation, the current A/D conversion is interrupted, and A/D conversion is performed on the first channel respecified by the ADS register. The partially converted data is discarded.
- <7> When ADCS is cleared to 0 during conversion operation, the current A/D conversion is interrupted, and the system enters the A/D conversion standby status.
- <8> When ADCE is cleared to 0 while in the A/D conversion standby status, the A/D converter enters the stop status. When ADCE = 0, specifying 1 for ADCS is ignored and A/D conversion does not start. In addition, A/D conversion does not start even if a hardware trigger is input while in the A/D conversion standby status.

Figure 11-20. Example of Software Trigger Mode (Scan Mode, One-Shot Conversion Mode) Operation Timing

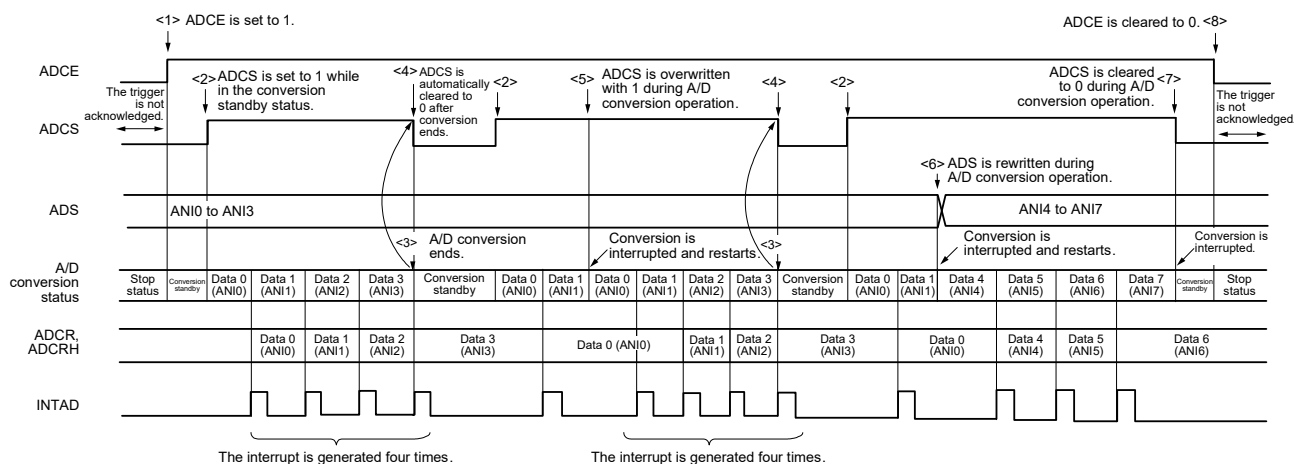

11.6.5 Hardware trigger no-wait mode (select mode, sequential conversion mode)

- <1> In the stop status, the ADCE bit of A/D converter mode register 0 (ADM0) is set to 1, and the system enters the A/D conversion standby status.
- <2> After the software counts up to the stabilization wait time (1 μs), the ADCS bit of the ADM0 register is set to 1 to place the system in the hardware trigger standby status (and conversion does not start at this stage). Note that, while in this status, A/D conversion does not start even if ADCS is set to 1.
- <3> If a hardware trigger is input while ADCS = 1, A/D conversion is performed on the analog input specified by the analog input channel specification register (ADS).
- <4> When A/D conversion ends, the conversion result is stored in the A/D conversion result register (ADCR, ADCRH), and the A/D conversion end interrupt request signal (INTAD) is generated. After A/D conversion ends, the next A/D conversion immediately starts.
- <5> If a hardware trigger is input during conversion operation, the current A/D conversion is interrupted, and conversion restarts. The partially converted data is discarded.
- <6> When the value of the ADS register is rewritten or overwritten during conversion operation, the current A/D conversion is interrupted, and A/D conversion is performed on the analog input respecified by the ADS register. The partially converted data is discarded.
- <7> When ADCS is overwritten with 1 during conversion operation, the current A/D conversion is interrupted, and conversion restarts. The partially converted data is discarded.
- <8> When ADCS is cleared to 0 during conversion operation, the current A/D conversion is interrupted, and the system enters the A/D conversion standby status. However, the A/D converter does not stop in this status.
- <9> When ADCE is cleared to 0 while in the A/D conversion standby status, the A/D converter enters the stop status. When ADCS = 0, inputting a hardware trigger is ignored and A/D conversion does not start.

Figure 11-21. Example of Hardware Trigger No-Wait Mode (Select Mode, Sequential Conversion Mode) Operation Timing

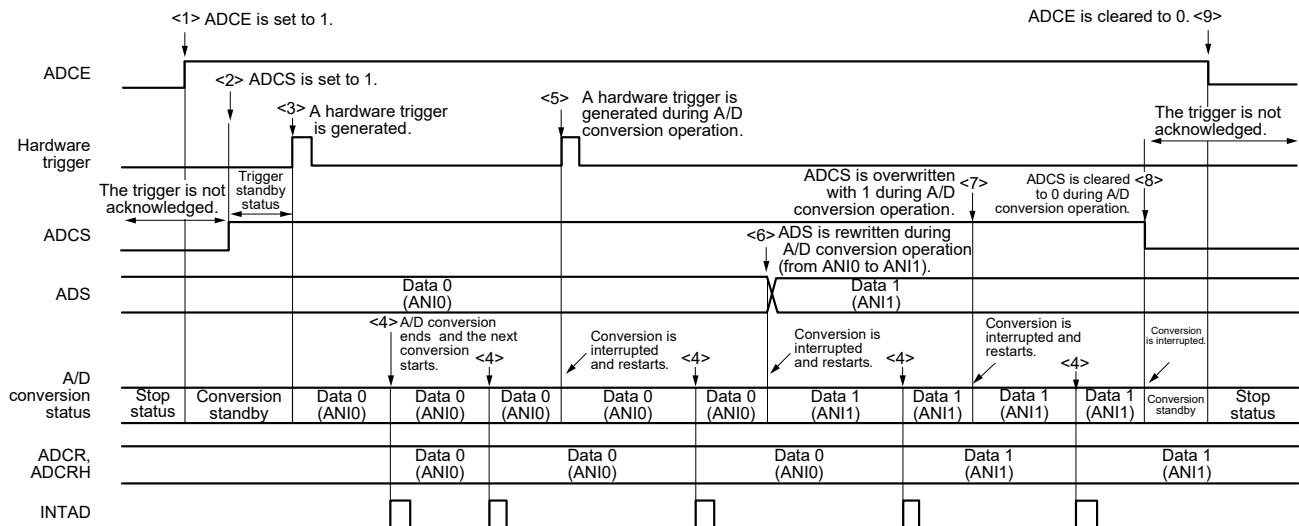

11.6.6 Hardware trigger no-wait mode (select mode, one-shot conversion mode)

- <1> In the stop status, the ADCE bit of A/D converter mode register 0 (ADM0) is set to 1, and the system enters the A/D conversion standby status.
- <2> After the software counts up to the stabilization wait time (1 μs), the ADCS bit of the ADM0 register is set to 1 to place the system in the hardware trigger standby status (and conversion does not start at this stage). Note that, while in this status, A/D conversion does not start even if ADCS is set to 1.
- <3> If a hardware trigger is input while ADCS = 1, A/D conversion is performed on the analog input specified by the analog input channel specification register (ADS).
- <4> When A/D conversion ends, the conversion result is stored in the A/D conversion result register (ADCR, ADCRH), and the A/D conversion end interrupt request signal (INTAD) is generated.
- <5> After A/D conversion ends, the ADCS bit remains set to 1, and the system enters the A/D conversion standby status.
- <6> If a hardware trigger is input during conversion operation, the current A/D conversion is interrupted, and conversion restarts. The partially converted data is discarded.
- <7> When the value of the ADS register is rewritten or overwritten during conversion operation, the current A/D conversion is interrupted, and A/D conversion is performed on the analog input respecified by the ADS register. The partially converted data is discarded.
- <8> When ADCS is overwritten with 1 during conversion operation, the current A/D conversion is interrupted, and conversion restarts. The partially converted data is discarded.
- <9> When ADCS is cleared to 0 during conversion operation, the current A/D conversion is interrupted, and the system enters the A/D conversion standby status. However, the A/D converter does not stop in this status.
- <10> When ADCE is cleared to 0 while in the A/D conversion standby status, the A/D converter enters the stop status. When ADCS = 0, inputting a hardware trigger is ignored and A/D conversion does not start.

Figure 11-22. Example of Hardware Trigger No-Wait Mode (Select Mode, One-Shot Conversion Mode) Operation Timing

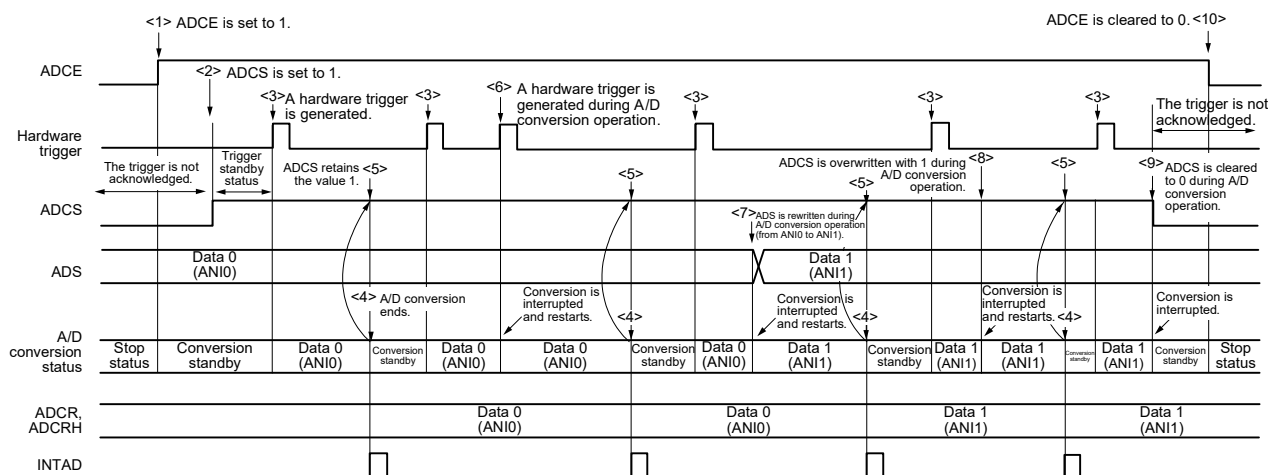

11.6.7 Hardware trigger no-wait mode (scan mode, sequential conversion mode)

- <1> In the stop status, the ADCE bit of A/D converter mode register 0 (ADM0) is set to 1, and the system enters the A/D conversion standby status.
- <2> After the software counts up to the stabilization wait time (1 μs), the ADCS bit of the ADM0 register is set to 1 to place the system in the hardware trigger standby status (and conversion does not start at this stage). Note that, while in this status, A/D conversion does not start even if ADCS is set to 1.
- <3> If a hardware trigger is input while ADCS = 1, A/D conversion is performed on the four analog input channels specified by scan 0 to scan 3, which are specified by the analog input channel specification register (ADS). A/D conversion is performed on the analog input channels in order, starting with that specified by scan 0.
- <4> A/D conversion is sequentially performed on the four analog input channels, the conversion results are stored in the A/D conversion result register (ADCR, ADCRH) each time conversion ends, and the A/D conversion end interrupt request signal (INTAD) is generated. After A/D conversion of the four channels ends, the A/D conversion of the channel following the specified channel automatically starts.
- <5> If a hardware trigger is input during conversion operation, the current A/D conversion is interrupted, and conversion restarts at the first channel. The partially converted data is discarded.
- <6> When the value of the ADS register is rewritten or overwritten during conversion operation, the current A/D conversion is interrupted, and A/D conversion is performed on the first channel respecified by the ADS register. The partially converted data is discarded.
- <7> When ADCS is overwritten with 1 during conversion operation, the current A/D conversion is interrupted, and conversion restarts. The partially converted data is discarded.
- <8> When ADCS is cleared to 0 during conversion operation, the current A/D conversion is interrupted, and the system enters the A/D conversion standby status. However, the A/D converter does not stop in this status.
- <9> When ADCE is cleared to 0 while in the A/D conversion standby status, the A/D converter enters the stop status. When ADCE = 0, specifying 1 for ADCS is ignored and A/D conversion does not start.

Figure 11-23. Example of Hardware Trigger No-Wait Mode (Scan Mode, Sequential Conversion Mode) Operation Timing

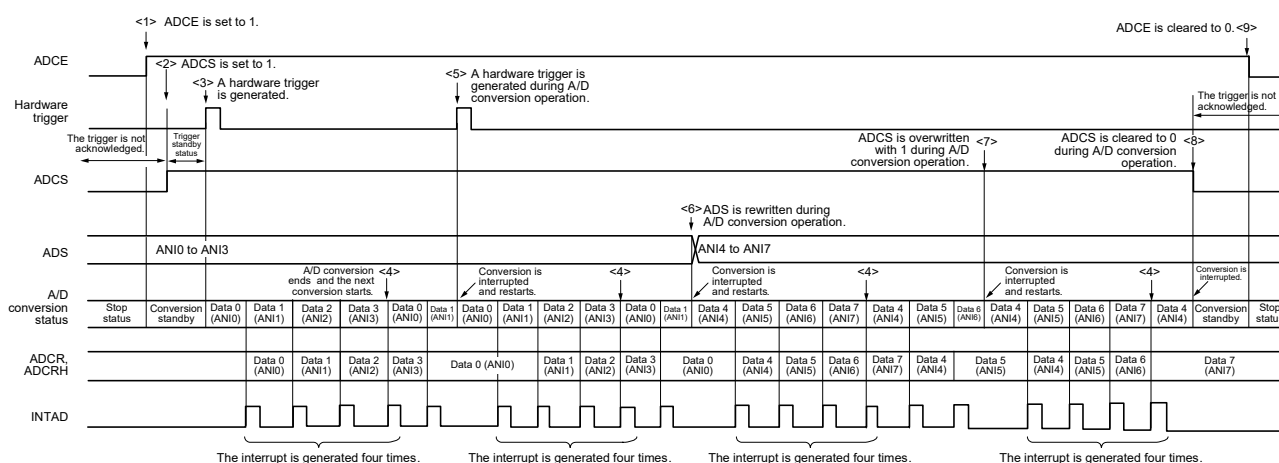

11.6.8 Hardware trigger no-wait mode (scan mode, one-shot conversion mode)

- <1> In the stop status, the ADCE bit of A/D converter mode register 0 (ADM0) is set to 1, and the system enters the A/D conversion standby status.
- <2> After the software counts up to the stabilization wait time (1 μs), the ADCS bit of the ADM0 register is set to 1 to place the system in the hardware trigger standby status (and conversion does not start at this stage). Note that, while in this status, A/D conversion does not start even if ADCS is set to 1.
- <3> If a hardware trigger is input while ADCS = 1, A/D conversion is performed on the four analog input channels specified by scan 0 to scan 3, which are specified by the analog input channel specification register (ADS). A/D conversion is performed on the analog input channels in order, starting with that specified by scan 0.
- <4> A/D conversion is sequentially performed on the four analog input channels, the conversion results are stored in the A/D conversion result register (ADCR, ADCRH) each time conversion ends, and the A/D conversion end interrupt request signal (INTAD) is generated.
- <5> After A/D conversion of the four channels ends, the ADCS bit remains set to 1, and the system enters the A/D conversion standby status.
- <6> If a hardware trigger is input during conversion operation, the current A/D conversion is interrupted, and conversion restarts at the first channel. The partially converted data is discarded.
- <7> When the value of the ADS register is rewritten or overwritten during conversion operation, the current A/D conversion is interrupted, and A/D conversion is performed on the first channel respecified by the ADS register. The partially converted data is discarded.
- <8> When ADCS is overwritten with 1 during conversion operation, the current A/D conversion is interrupted, and conversion restarts at the first channel. The partially converted data is discarded.
- <9> When ADCS is cleared to 0 during conversion operation, the current A/D conversion is interrupted, and the system enters the A/D conversion standby status. However, the A/D converter does not stop in this status.
- <10> When ADCE is cleared to 0 while in the A/D conversion standby status, the A/D converter enters the stop status. When ADCS = 0, inputting a hardware trigger is ignored and A/D conversion does not start.

Figure 11-24. Example of Hardware Trigger No-Wait Mode (Scan Mode, One-Shot Conversion Mode) Operation Timing

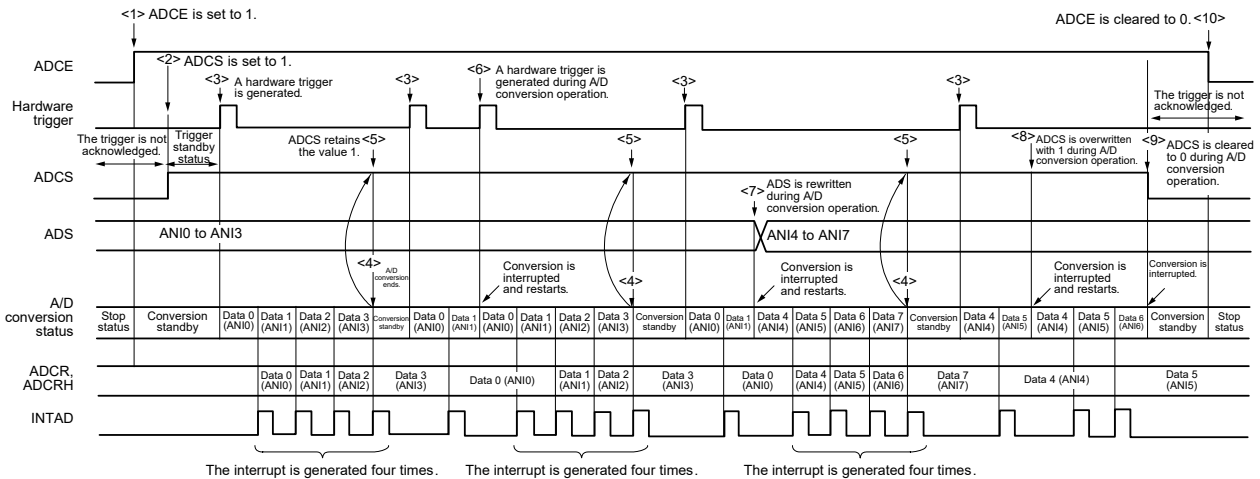

11.6.9 Hardware trigger wait mode (select mode, sequential conversion mode)

- <1> In the stop status, the ADCE bit of A/D converter mode register 0 (ADM0) is set to 1, and the system enters the hardware trigger standby status.
- <2> If a hardware trigger is input while in the hardware trigger standby status, A/D conversion is performed on the analog input specified by the analog input channel specification register (ADS). The ADCS bit of the ADM0 register is automatically set to 1 according to the hardware trigger input.
- <3> When A/D conversion ends, the conversion result is stored in the A/D conversion result register (ADCR, ADCRH), and the A/D conversion end interrupt request signal (INTAD) is generated. After A/D conversion ends, the next A/D conversion immediately starts. (At this time, no hardware trigger is necessary.)
- <4> If a hardware trigger is input during conversion operation, the current A/D conversion is interrupted, and conversion restarts. The partially converted data is discarded.
- <5> When the value of the ADS register is rewritten or overwritten during conversion operation, the current A/D conversion is interrupted, and A/D conversion is performed on the analog input respecified by the ADS register. The partially converted data is discarded.
- <6> When ADCS is overwritten with 1 during conversion operation, the current A/D conversion is interrupted, and conversion restarts. The partially converted data is discarded.
- <7> When ADCS is cleared to 0 during conversion operation, the current A/D conversion is interrupted, the system enters the hardware trigger standby status, and the A/D converter enters the stop status. When ADCE = 0, inputting a hardware trigger is ignored and A/D conversion does not start.

Figure 11-25. Example of Hardware Trigger Wait Mode (Select Mode, Sequential Conversion Mode) Operation Timing

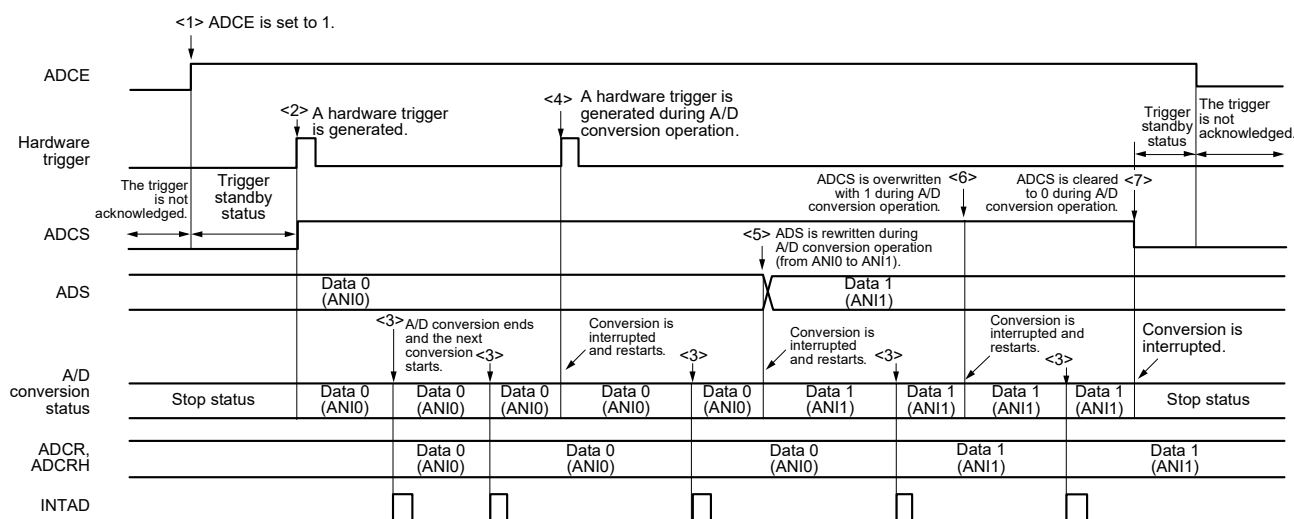

11.6.10 Hardware trigger wait mode (select mode, one-shot conversion mode)

- <1> In the stop status, the ADCE bit of A/D converter mode register 0 (ADM0) is set to 1, and the system enters the hardware trigger standby status.
- <2> If a hardware trigger is input while in the hardware trigger standby status, A/D conversion is performed on the analog input specified by the analog input channel specification register (ADS). The ADCS bit of the ADM0 register is automatically set to 1 according to the hardware trigger input.
- <3> When A/D conversion ends, the conversion result is stored in the A/D conversion result register (ADCR, ADCRH), and the A/D conversion end interrupt request signal (INTAD) is generated.
- <4> After A/D conversion ends, the ADCS bit is automatically cleared to 0, and the A/D converter enters the stop status.
- <5> If a hardware trigger is input during conversion operation, the current A/D conversion is interrupted, and conversion restarts. The partially converted data is discarded.
- <6> When the value of the ADS register is rewritten or overwritten during conversion operation, the current A/D conversion is interrupted, and A/D conversion is performed on the analog input respecified by the ADS register. The partially converted data is discarded.
- <7> When ADCS is overwritten with 1 during conversion operation, the current A/D conversion is interrupted, and conversion restarts. The partially converted data is initialized.
- <8> When ADCS is cleared to 0 during conversion operation, the current A/D conversion is interrupted, the system enters the hardware trigger standby status, and the A/D converter enters the stop status. When ADCE = 0, inputting a hardware trigger is ignored and A/D conversion does not start.

Figure 11-26. Example of Hardware Trigger Wait Mode (Select Mode, One-Shot Conversion Mode) Operation Timing

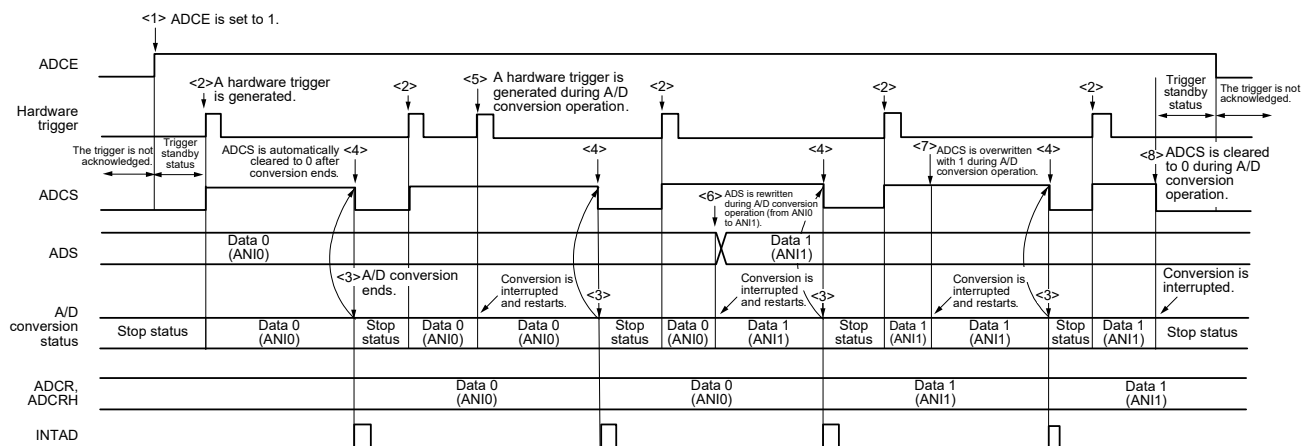

11.6.11 Hardware trigger wait mode (scan mode, sequential conversion mode)

- <1> In the stop status, the ADCE bit of A/D converter mode register 0 (ADM0) is set to 1, and the system enters the A/D conversion standby status.
- <2> If a hardware trigger is input while in the hardware trigger standby status, A/D conversion is performed on the four analog input channels specified by scan 0 to scan 3, which are specified by the analog input channel specification register (ADS). The ADCS bit of the ADM0 register is automatically set to 1 according to the hardware trigger input. A/D conversion is performed on the analog input channels in order, starting with that specified by scan 0.
- <3> A/D conversion is sequentially performed on the four analog input channels, the conversion results are stored in the A/D conversion result register (ADCR, ADCRH) each time conversion ends, and the A/D conversion end interrupt request signal (INTAD) is generated. After A/D conversion of the four channels ends, the A/D conversion of the channel following the specified channel automatically starts.
- <4> If a hardware trigger is input during conversion operation, the current A/D conversion is interrupted, and conversion restarts at the first channel. The partially converted data is discarded.
- <5> When the value of the ADS register is rewritten or overwritten during conversion operation, the current A/D conversion is interrupted, and A/D conversion is performed on the first channel respecified by the ADS register. The partially converted data is discarded.
- <6> When ADCS is overwritten with 1 during conversion operation, the current A/D conversion is interrupted, and conversion restarts. The partially converted data is discarded.
- <7> When ADCS is cleared to 0 during conversion operation, the current A/D conversion is interrupted, the system enters the hardware trigger standby status, and the A/D converter enters the stop status. When ADCE = 0, inputting a hardware trigger is ignored and A/D conversion does not start.

Figure 11-27. Example of Hardware Trigger Wait Mode (Scan Mode, Sequential Conversion Mode) Operation Timing

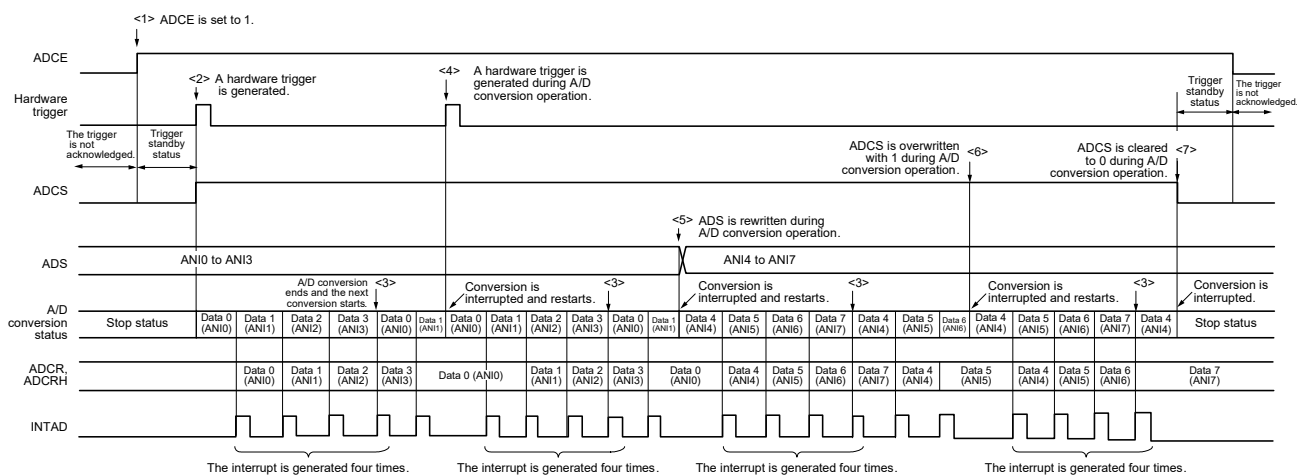

11.6.12 Hardware trigger wait mode (scan mode, one-shot conversion mode)

- <1> In the stop status, the ADCE bit of A/D converter mode register 0 (ADM0) is set to 1, and the system enters the A/D conversion standby status.
- <2> If a hardware trigger is input while in the hardware trigger standby status, A/D conversion is performed on the four analog input channels specified by scan 0 to scan 3, which are specified by the analog input channel specification register (ADS). The ADCS bit of the ADM0 register is automatically set to 1 according to the hardware trigger input. A/D conversion is performed on the analog input channels in order, starting with that specified by scan 0.
- <3> A/D conversion is sequentially performed on the four analog input channels, the conversion results are stored in the A/D conversion result register (ADCR, ADCRH) each time conversion ends, and the A/D conversion end interrupt request signal (INTAD) is generated.
- <4> After A/D conversion ends, the ADCS bit is automatically cleared to 0, and the A/D converter enters the stop status.
- <5> If a hardware trigger is input during conversion operation, the current A/D conversion is interrupted, and conversion restarts at the first channel. The partially converted data is discarded.
- <6> When the value of the ADS register is rewritten or overwritten during conversion operation, the current A/D conversion is interrupted, and A/D conversion is performed on the first channel respecified by the ADS register. The partially converted data is discarded.
- <7> When ADCS is overwritten with 1 during conversion operation, the current A/D conversion is interrupted, and conversion restarts. The partially converted data is discarded.
- <8> When ADCS is cleared to 0 during conversion operation, the current A/D conversion is interrupted, the system enters the hardware trigger standby status, and the A/D converter enters the stop status. When ADCE = 0, inputting a hardware trigger is ignored and A/D conversion does not start.

Figure 11-28. Example of Hardware Trigger Wait Mode (Scan Mode, One-Shot Conversion Mode) Operation Timing

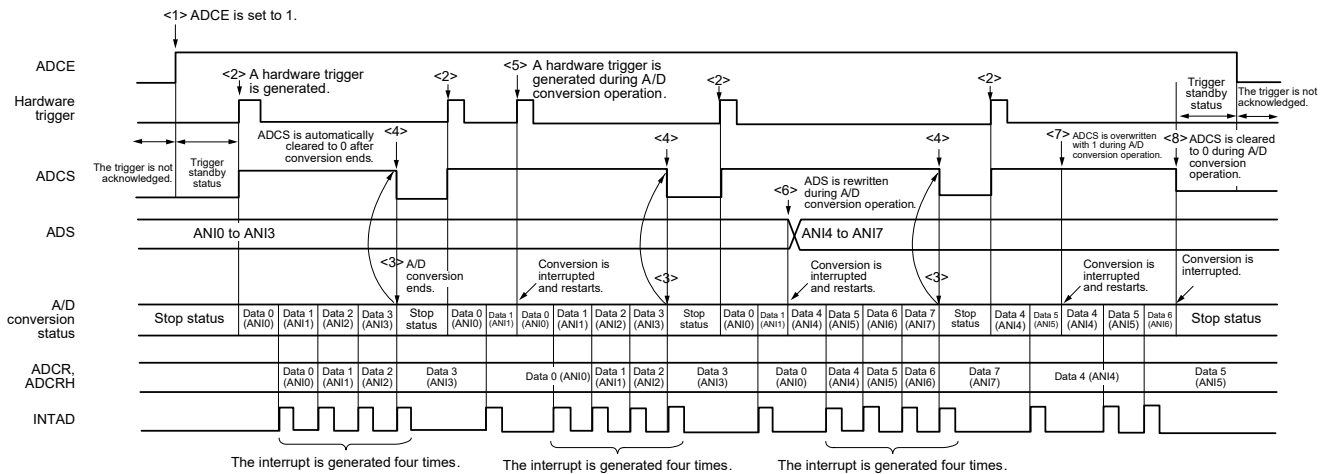

11.7 A/D Converter Setup Flowchart

The A/D converter setup flowchart in each operation mode is described below.

11.7.1 Setting up software trigger mode

Figure 11-29. Setting up Software Trigger Mode

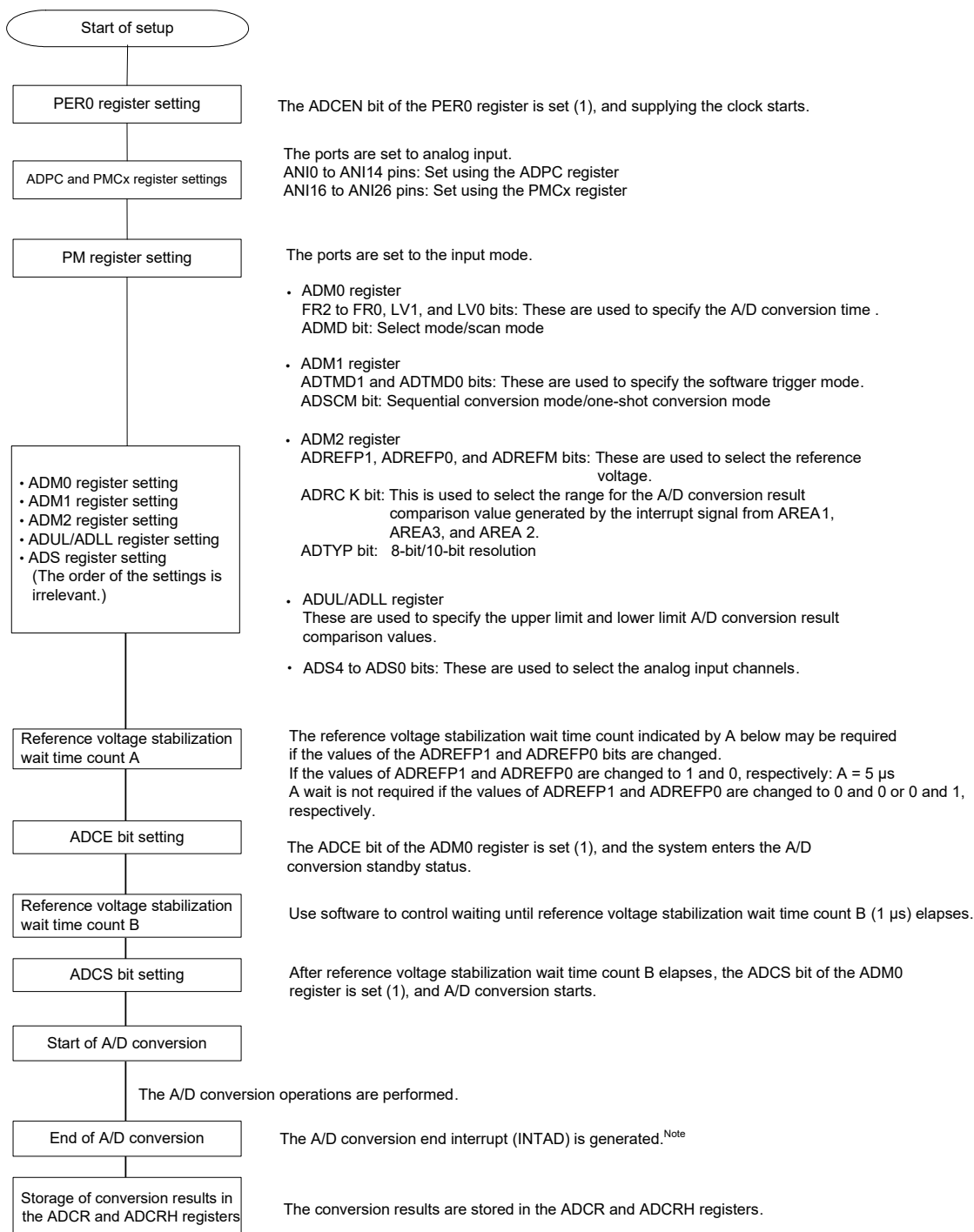

Note Depending on the settings of the ADRCK bit and ADUL/ADLL register, there is a possibility of no interrupt signal being generated. In this case, the results are not stored in the ADCR and ADCRH registers.

11.7.2 Setting up hardware trigger no-wait mode

Figure 11-30. Setting up Hardware Trigger No-Wait Mode

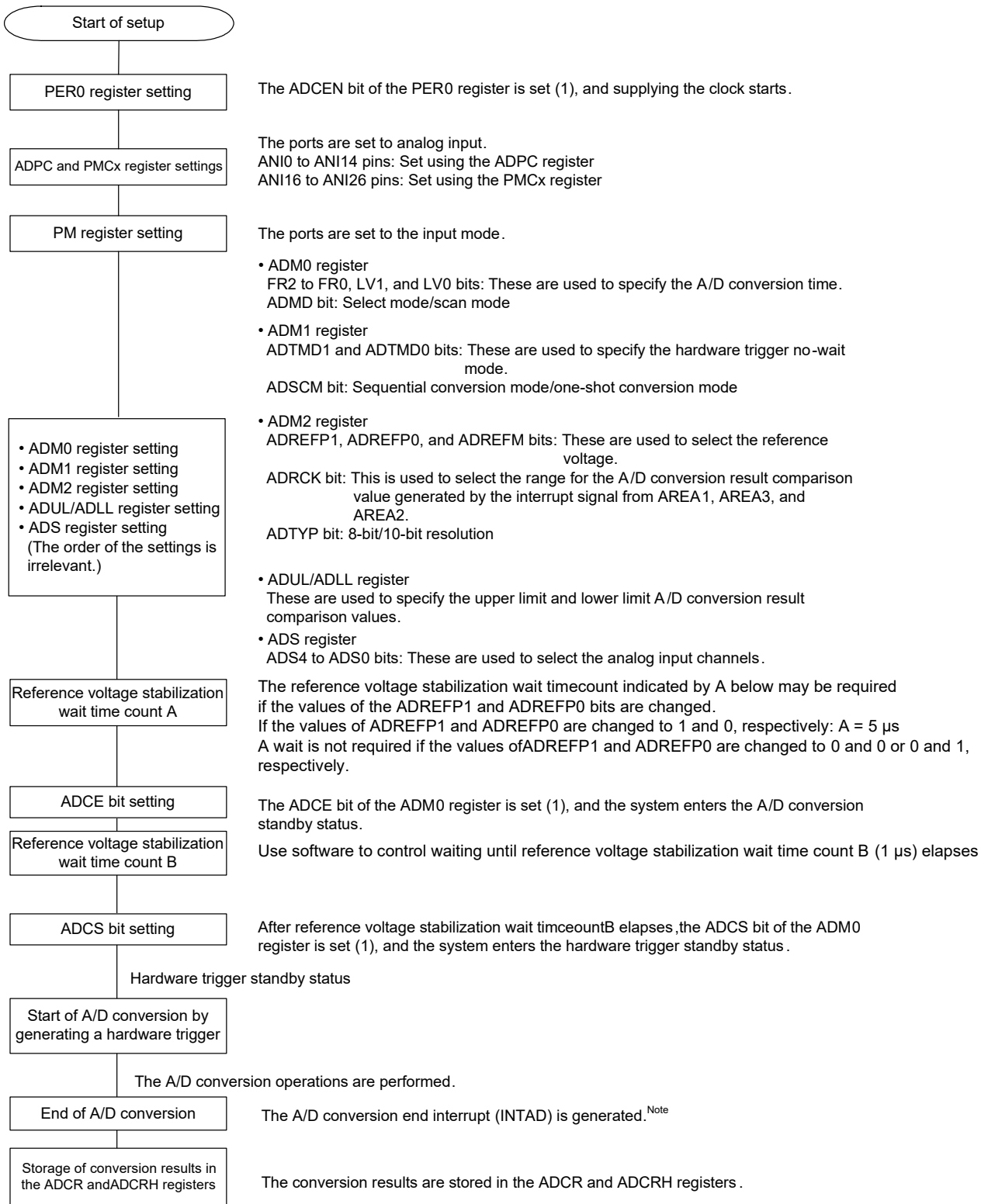

Note Depending on the settings of the ADRCK bit and ADUL/ADLL register, there is a possibility of no interrupt signal being generated. In this case, the results are not stored in the ADCR and ADCRH registers.

11.7.3 Setting up hardware trigger wait mode

Figure 11-31. Setting up Hardware Trigger Wait Mode

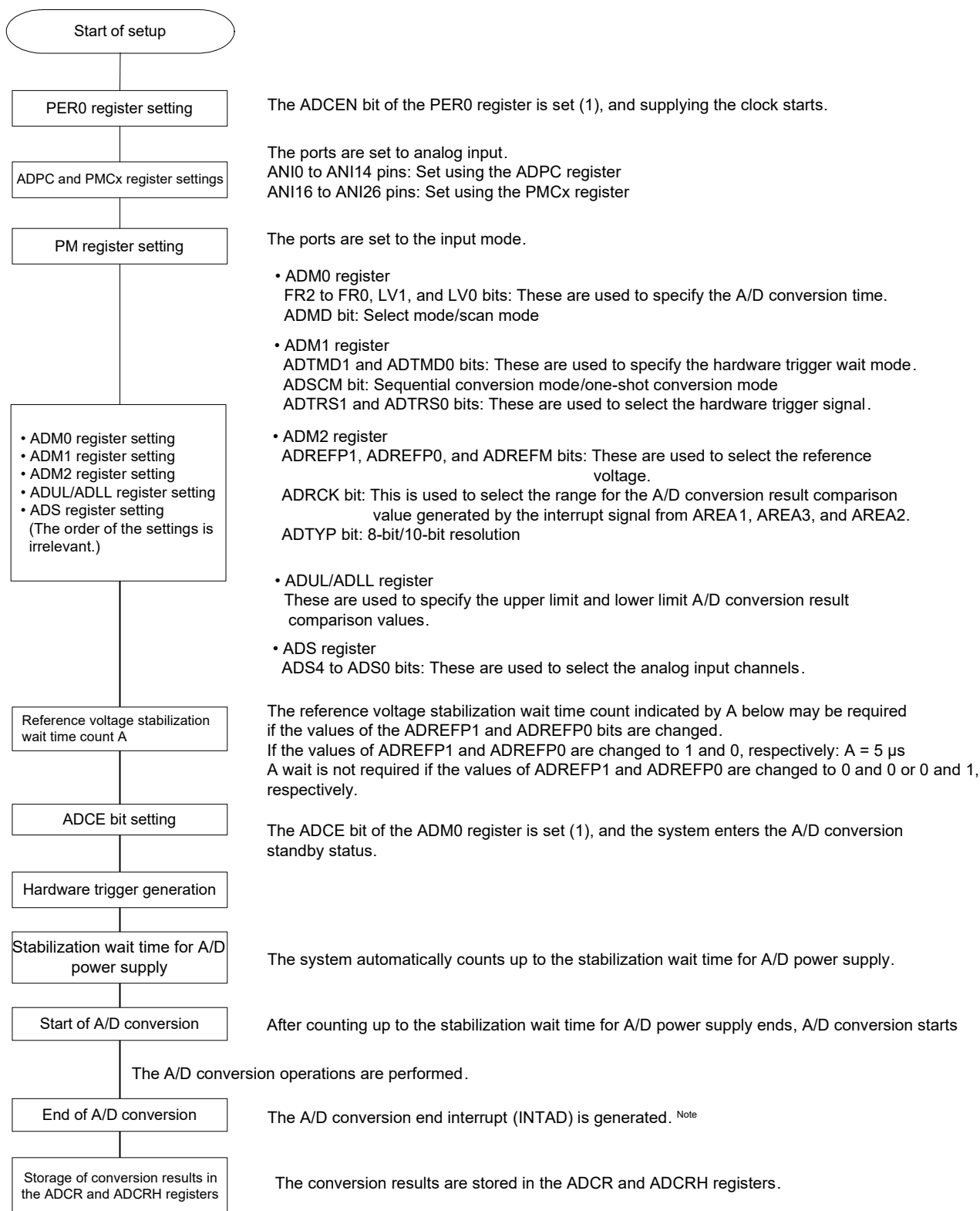

Note Depending on the settings of the ADRCK bit and ADUL/ADLL register, there is a possibility of no interrupt signal being generated. In this case, the results are not stored in the ADCR and ADCRH registers.

11.7.4 Setup when temperature sensor output voltage/internal reference voltage is selected (example for software trigger mode and one-shot conversion mode)

Figure 11-32. Setup when temperature sensor output voltage/internal reference voltage is selected

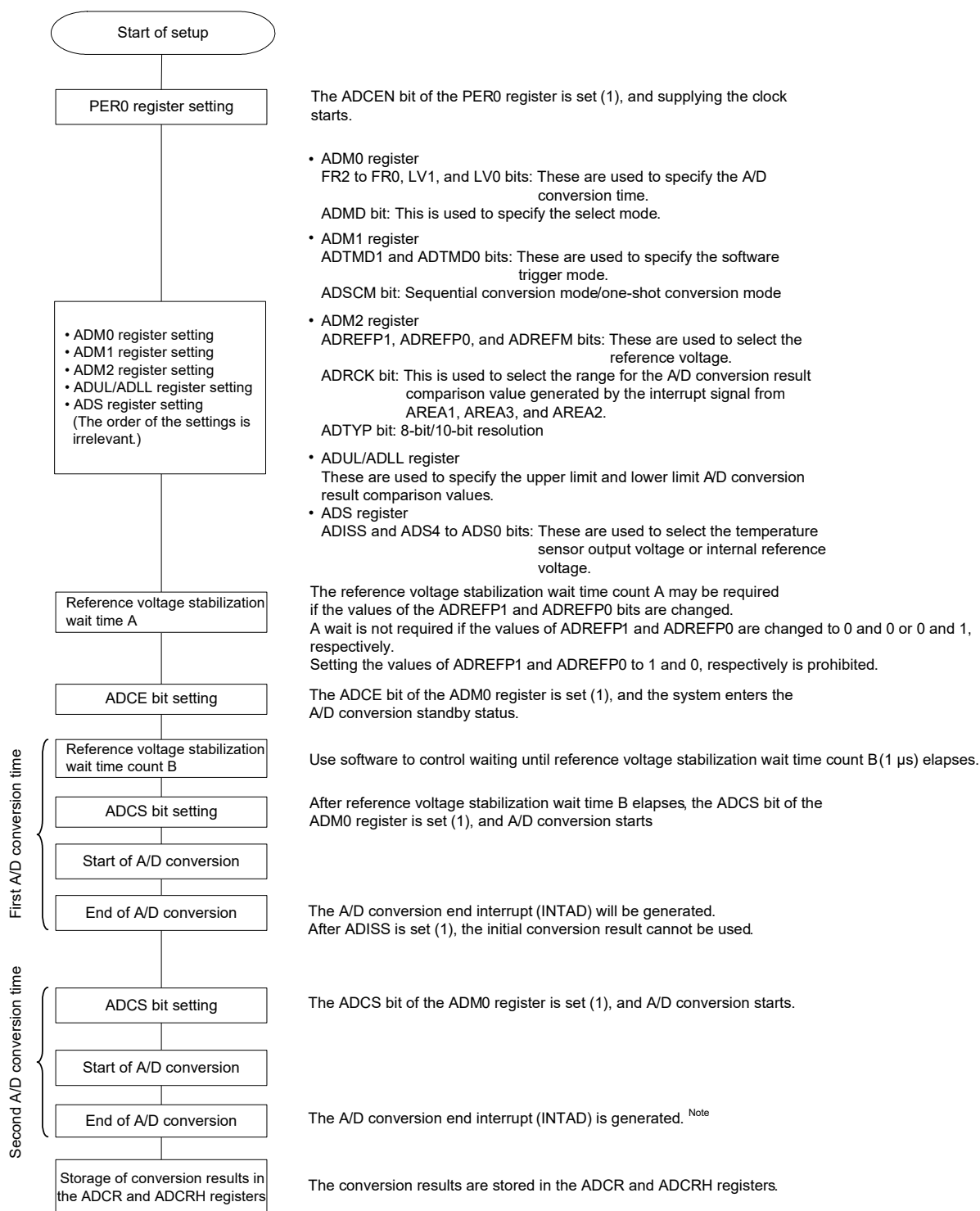

Note Depending on the settings of the ADRCK bit and ADUL/ADLL register, there is a possibility of no interrupt signal being generated. In this case, the results are not stored in the ADCR and ADCRH registers.

Caution This setting can be used only in HS (high-speed main) mode.

11.7.5 Setting up test mode

Figure 11-33. Setting up Test Mode

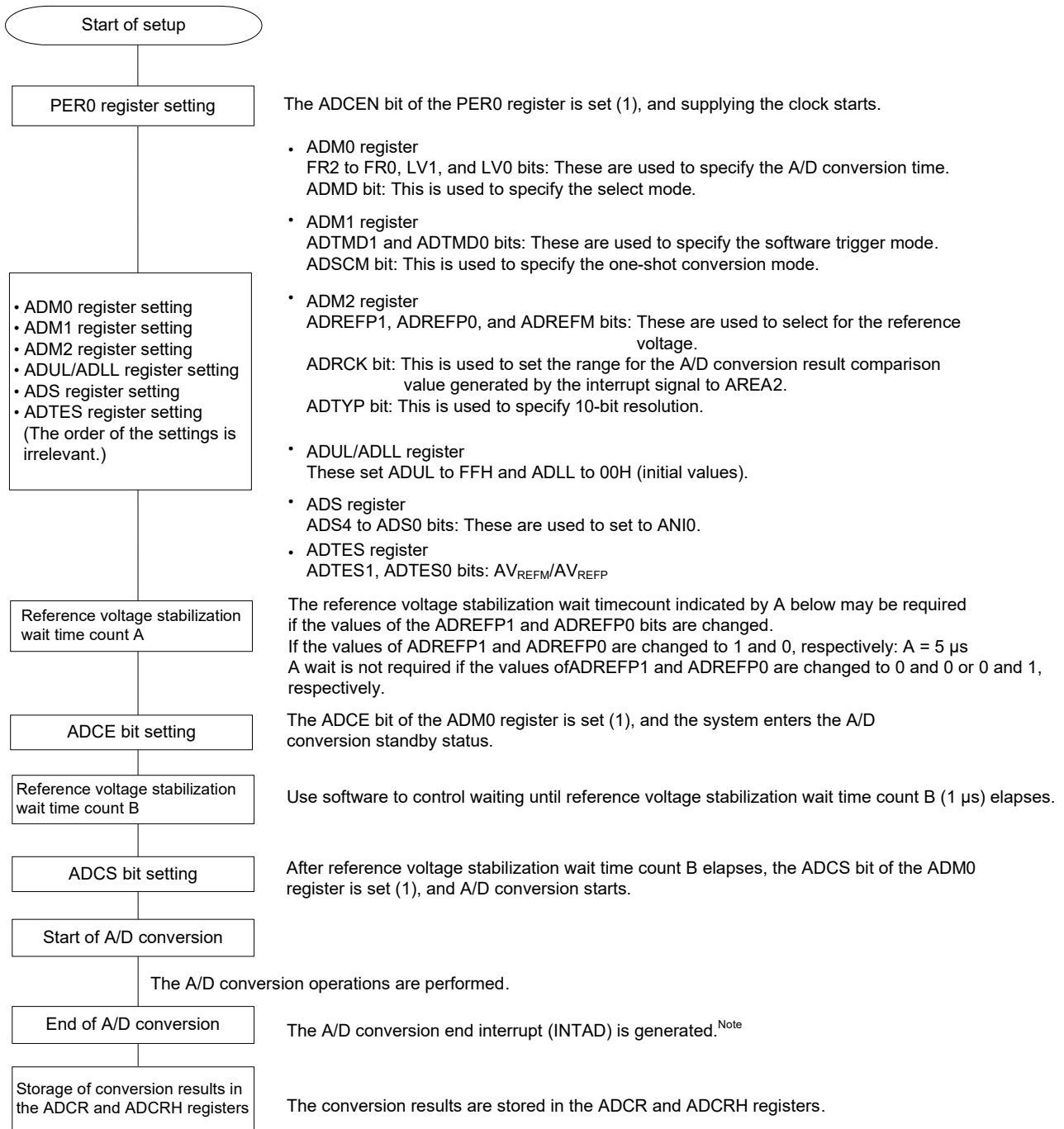

Note Depending on the settings of the ADRCK bit and ADUL/ADLL register, there is a possibility of no interrupt signal being generated. In this case, the results are not stored in the ADCR and ADCRH registers.

Caution For the procedure for testing the A/D converter, see 22.3.8 A/D test function.

11.8 SNOOZE Mode Function

In the SNOOZE mode, A/D conversion is triggered by inputting a hardware trigger in the STOP mode. Normally, A/D conversion is stopped while in the STOP mode, but, by using the SNOOZE mode function, A/D conversion can be performed without operating the CPU. This is effective for reducing the operating current.

If the A/D conversion result range is specified using the ADUL and ADLL registers, A/D conversion results can be judged at a certain interval of time in SNOOZE mode. Using this function enables power supply voltage monitoring and input key judgment based on A/D inputs.

In the SNOOZE mode, only the following two conversion modes can be used:

- Hardware trigger wait mode (select mode, one-shot conversion mode)
- Hardware trigger wait mode (scan mode, one-shot conversion mode)

Caution That the SNOOZE mode can only be specified when the high-speed on-chip oscillator clock is selected for f_{CLK}.

Figure 11-34. Block Diagram When Using SNOOZE Mode Function

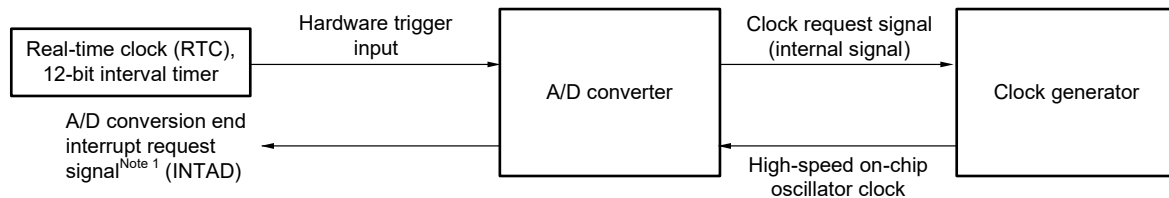

When using the SNOOZE mode function, the initial setting of each register is specified before switching to the STOP mode (for details about these settings, see **11.7.3 Setting up hardware trigger wait mode** ^{Note 2}). Just before move to STOP mode, bit 2 (AWC) of A/D converter mode register 2 (ADM2) is set to 1. After the initial settings are specified, bit 0 (ADCE) of A/D converter mode register 0 (ADM0) is set to 1.

If a hardware trigger is input after switching to the STOP mode, the high-speed on-chip oscillator clock is supplied to the A/D converter. After supplying this clock, the system automatically counts up to the A/D power supply stabilization wait time, and then A/D conversion starts.

The SNOOZE mode operation after A/D conversion ends differs depending on whether an interrupt signal is generated^{Note 1}.

- Notes**
1. Depending on the setting of the A/D conversion result comparison function (ADRCK bit, ADUL/ADLL register), there is a possibility of no interrupt signal being generated.
 2. Be sure to set the ADM1 register to E2H or E3H.

Remark The hardware trigger is INTRTC or INTIT.
Specify the hardware trigger by using the A/D Converter Mode Register 1 (ADM1).

(1) If an interrupt is generated after A/D conversion ends

If the A/D conversion result value is inside the range of values specified by the A/D conversion result comparison function (which is set up by using the ADRCK bit and ADUL/ADLL register), the A/D conversion end interrupt request signal (INTAD) is generated.

- While in the select mode

When A/D conversion ends and an A/D conversion end interrupt request signal (INTAD) is generated, the A/D converter returns to normal operation mode from SNOOZE mode. At this time, be sure to clear bit 2 (AWC = 0: SNOOZE mode release) of the A/D converter mode register 2 (ADM2). If the AWC bit is left set to 1, A/D conversion will not start normally in the subsequent SNOOZE or normal operation mode.

- While in the scan mode

If even one A/D conversion end interrupt request signal (INTAD) is generated during A/D conversion of the four channels, the clock request signal remains at the high level, and the A/D converter switches from the SNOOZE mode to the normal operation mode. At this time, be sure to clear bit 2 (AWC = 0: SNOOZE mode release) of A/D converter mode register 2 (ADM2) to 0. If the AWC bit is left set to 1, A/D conversion will not start normally in the subsequent SNOOZE or normal operation mode.

Figure 11-35. Operation Example When Interrupt Is Generated After A/D Conversion Ends (While in Scan Mode)

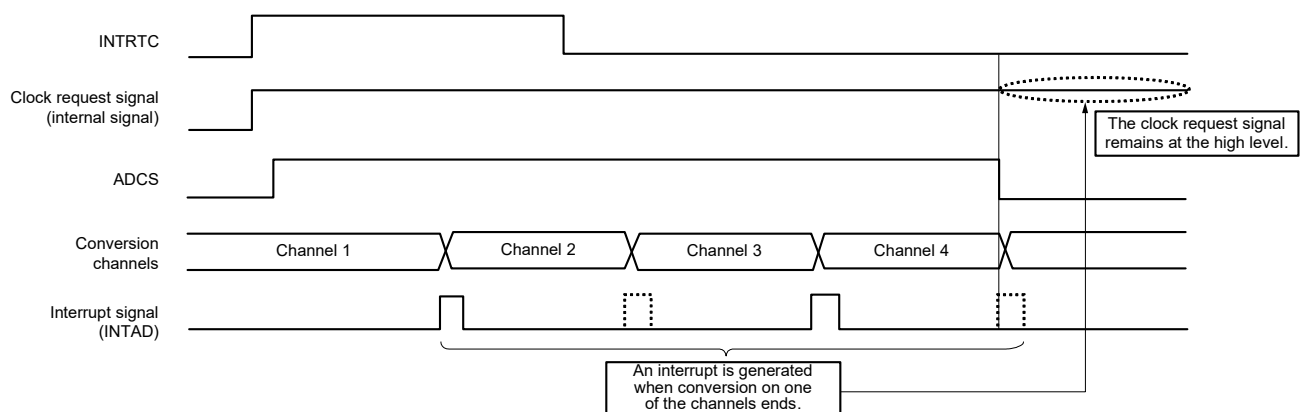

(2) If no interrupt is generated after A/D conversion ends

If the A/D conversion result value is outside the range of values specified by the A/D conversion result comparison function (which is set up by using the ADRCK bit and ADUL/ADLL register), the A/D conversion end interrupt request signal (INTAD) is not generated.

- While in the select mode

If the A/D conversion end interrupt request signal (INTAD) is not generated after A/D conversion ends, the clock request signal (an internal signal) is automatically set to the low level, and supplying the high-speed on-chip oscillator clock stops. If a hardware trigger is input later, A/D conversion work is again performed in the SNOOZE mode.

- While in the scan mode

If the A/D conversion end interrupt request signal (INTAD) is not generated even once during A/D conversion of the four channels, the clock request signal (an internal signal) is automatically set to the low level after A/D conversion of the four channels ends, and supplying the high-speed on-chip oscillator clock stops. If a hardware trigger is input later, A/D conversion work is again performed in the SNOOZE mode.

Figure 11-36. Operation Example When No Interrupt Is Generated After A/D Conversion Ends (While in Scan Mode)

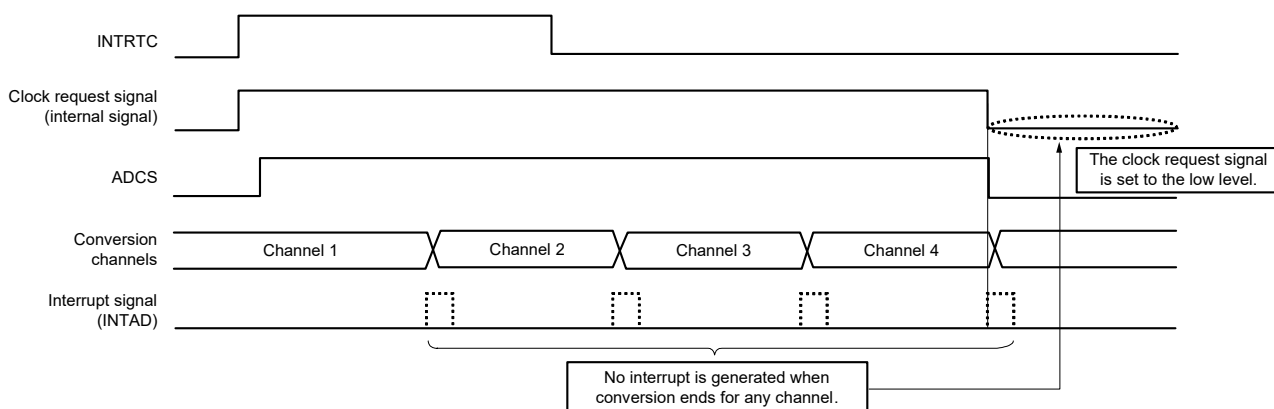
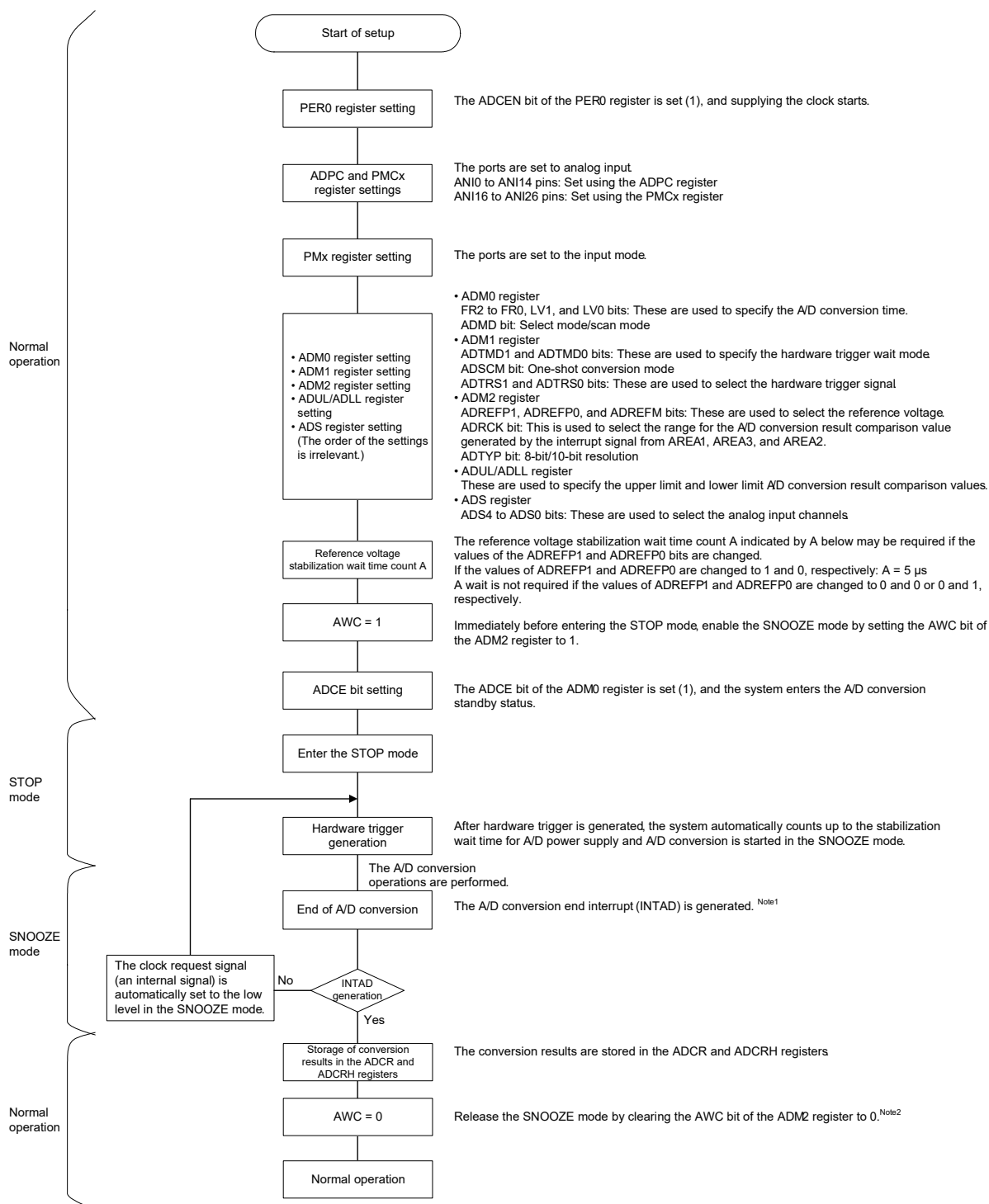

Figure 11-37. Flowchart for Setting up SNOOZE Mode



- Notes**
- If the A/D conversion end interrupt request signal (INTAD) is not generated by setting ADRCK bit and ADUL/ADLL register, the result is not stored in the ADCR and ADCRH registers. The system enters the STOP mode again. If a hardware trigger is input later, A/D conversion operation is again performed in the SNOOZE mode.
 - If the AWC bit is left set to 1, A/D conversion will not start normally in spite of the subsequent SNOOZE or normal operation mode. Be sure to clear the AWC bit to 0.

11.9 How to Read A/D Converter Characteristics Table

Here, special terms unique to the A/D converter are explained.

(1) Resolution

This is the minimum analog input voltage that can be identified. That is, the percentage of the analog input voltage per bit of digital output is called 1LSB (Least Significant Bit). The percentage of 1LSB with respect to the full scale is expressed by %FSR (Full Scale Range).

1LSB is as follows when the resolution is 10 bits.

$$1\text{LSB} = 1/2^{10} = 1/1024$$

$$= 0.098\%\text{FSR}$$

Accuracy has no relation to resolution, but is determined by overall error.

(2) Overall error

This shows the maximum error value between the actual measured value and the theoretical value. Zero-scale error, full-scale error, integral linearity error, and differential linearity errors that are combinations of these express the overall error.

Note that the quantization error is not included in the overall error in the characteristics table.

(3) Quantization error

When analog values are converted to digital values, a $\pm 1/2\text{LSB}$ error naturally occurs. In an A/D converter, an analog input voltage in a range of $\pm 1/2\text{LSB}$ is converted to the same digital code, so a quantization error cannot be avoided.

Note that the quantization error is not included in the overall error, zero-scale error, full-scale error, integral linearity error, and differential linearity error in the characteristics table.

Figure 11-38. Overall Error

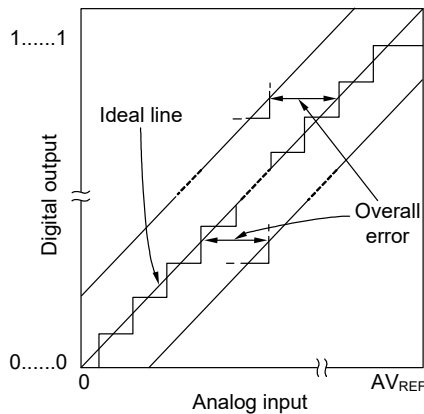
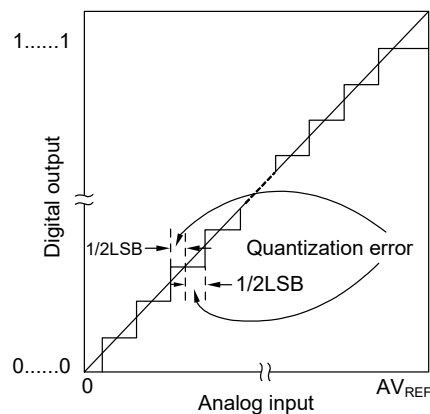

Figure 11-39. Quantization Error



(4) Zero-scale error

This shows the difference between the actual measurement value of the analog input voltage and the theoretical value ($1/2\text{LSB}$) when the digital output changes from $0.....000$ to $0.....001$.

If the actual measurement value is greater than the theoretical value, it shows the difference between the actual measurement value of the analog input voltage and the theoretical value ($3/2\text{LSB}$) when the digital output changes from $0.....001$ to $0.....010$.

(5) Full-scale error

This shows the difference between the actual measurement value of the analog input voltage and the theoretical value (Full-scale – 3/2LSB) when the digital output changes from 1.....110 to 1.....111.

(6) Integral linearity error

This shows the degree to which the conversion characteristics deviate from the ideal linear relationship. It expresses the maximum value of the difference between the actual measurement value and the ideal straight line when the zero-scale error and full-scale error are 0.

(7) Differential linearity error

While the ideal width of code output is 1LSB, this indicates the difference between the actual measurement value and the ideal value.

Figure 11-40. Zero-Scale Error

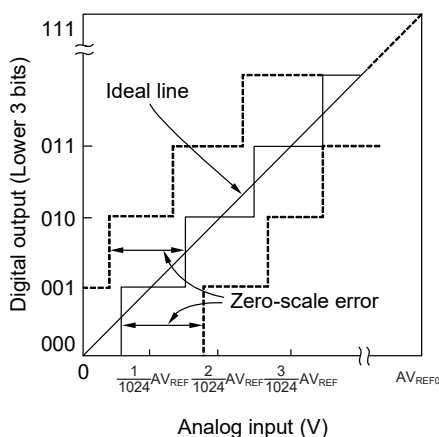

Figure 11-41. Full-Scale Error

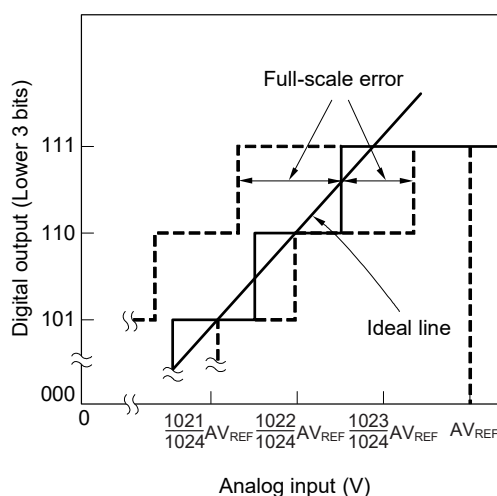

Figure 11-42. Integral Linearity Error

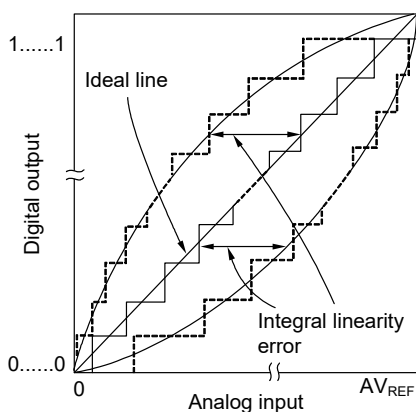
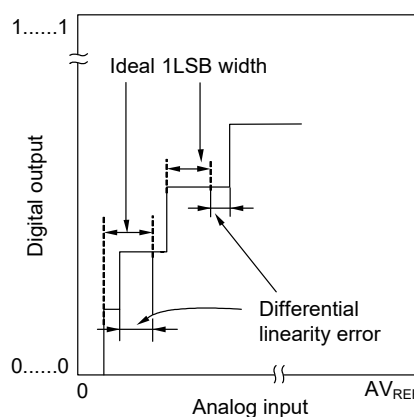

Figure 11-43. Differential Linearity Error



(8) Conversion time

This expresses the time from the start of sampling to when the digital output is obtained. The sampling time is included in the conversion time in the characteristics table.

(9) Sampling time

This is the time the analog switch is turned on for the analog voltage to be sampled by the sample & hold circuit.

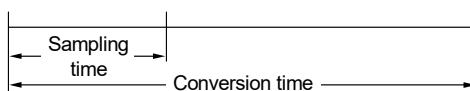

11.10 Cautions for A/D Converter

(1) Operating current in STOP mode

Shift to STOP mode after stopping the A/D converter (by setting bit 7 (ADCS) of A/D converter mode register 0 (ADM0) to 0). The operating current can be reduced by setting bit 0 (ADCE) of the ADM0 register to 0 at the same time.

To restart from the standby status, clear bit 0 (ADIF) of interrupt request flag register 1H (IF1H) to 0 and start operation.

(2) Input range of ANI0 to ANI14 and ANI16 to ANI26 pins

Observe the rated range of the ANI0 to ANI14 and ANI16 to ANI26 pins input voltage. If a voltage exceeding V_{DD} and AV_{REFP} or a voltage lower than V_{SS} and AV_{REFM} (even in the range of absolute maximum ratings) is input to an analog input channel, the converted value of that channel becomes undefined. In addition, the converted values of the other channels may also be affected.

When internal reference voltage (1.45 V) is selected as the reference voltage for the + side of the A/D converter, do not input a voltage equal to or higher than the internal reference voltage (1.45 V) to a pin selected by the ADS register. However, it is no problem that a voltage equal to or higher than the internal reference voltage (1.45 V) is input to a pin not selected by the ADS register.

Caution Internal reference voltage (1.45 V) can be used only in HS (high-speed main) mode.

(3) Conflicting operations

<1> Conflict between the A/D conversion result register (ADCR, ADCRH) write and the ADCR or ADCRH register read by instruction upon the end of conversion

The ADCR or ADCRH register read has priority. After the read operation, the new conversion result is written to the ADCR or ADCRH registers.

<2> Conflict between the ADCR or ADCRH register write and the A/D converter mode register 0 (ADM0) write, the analog input channel specification register (ADS), or A/D port configuration register (ADPC) write upon the end of conversion

The ADM0, ADS, or ADPC registers write has priority. The ADCR or ADCRH register write is not performed, nor is the conversion end interrupt signal (INTAD) generated.

(4) Noise countermeasures

To maintain the 10-bit resolution, attention must be paid to noise input to the AV_{REFP} , V_{DD} , ANI0 to ANI14, and ANI16 to ANI26 pins.

<1> Connect a capacitor with a low equivalent resistance and a good frequency response (capacitance of about 0.01 μ F) via the shortest possible run of relatively thick wiring to the power supply.

<2> The higher the output impedance of the analog input source, the greater the influence. To reduce the noise, connecting an external capacitor as shown in **Figure 11-44** is recommended.

<3> Do not switch these pins with other pins during conversion.

<4> The accuracy is improved if the HALT mode is set immediately after the start of conversion.

Figure 11-44. Analog Input Pin Connection

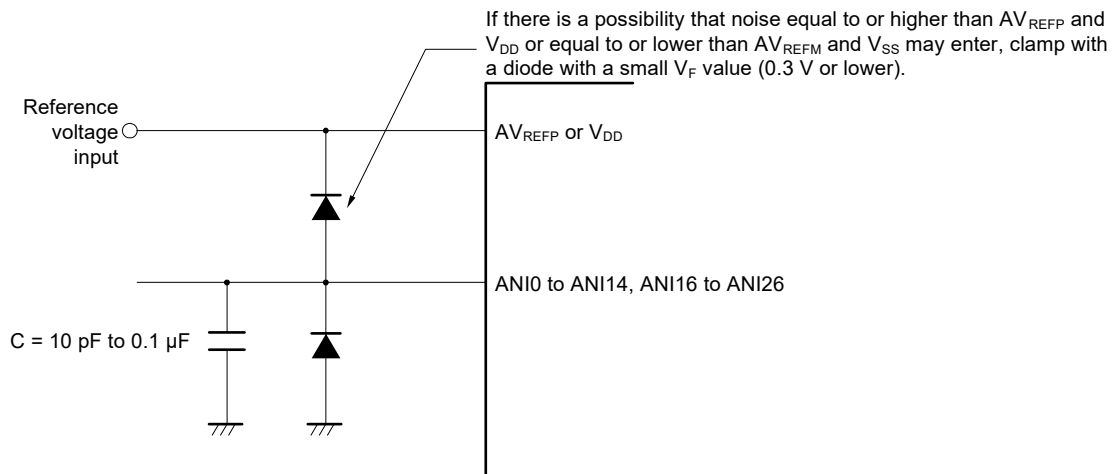

(5) Analog input (ANIn) pins

- <1> The analog input pins (ANI0 to ANI14) are also used as input port pins (P20 to P27, P150 to P156). When A/D conversion is performed with any of the ANI0 to ANI14 pins selected, do not change to output value P20 to P27, P150 to P156 while conversion is in progress; otherwise the conversion resolution may be degraded.
- <2> If a pin adjacent to a pin that is being A/D converted is used as a digital I/O port pin, the A/D conversion result might differ from the expected value due to a coupling noise. Be sure to prevent such a pulse from being input or output. Be sure to avoid the input or output of digital signals and signals with similarly sharp transitions during conversion.

(6) Input impedance of analog input (ANIn) pins

This A/D converter charges a sampling capacitor for sampling during sampling time.

Therefore, only a leakage current flows when sampling is not in progress, and a current that charges the capacitor flows during sampling. Consequently, the input impedance fluctuates depending on whether sampling is in progress, and on the other states.

To make sure that sampling is effective, however, we recommend using the converter with analog input sources that have output impedances no greater than 1 kΩ. If a source has a higher output impedance, lengthen the sampling time or connect a larger capacitor (with a value of about 0.1 μF) to the pin from among ANI0 to ANI14 and ANI16 to ANI26 to which the source is connected (see **Figure 11-44**). The sampling capacitor may be being charged while the setting of the ADCS bit is 0 and immediately after sampling is restarted and so is not defined at these times. Accordingly, the state of conversion is undefined after charging starts in the next round of conversion after the value of the ADCS bit has been 1 or when conversion is repeated. Thus, to secure full charging regardless of the size of fluctuations in the analog signal, ensure that the output impedances of the sources of analog inputs are low or secure sufficient time for the completion of conversion.

(7) Interrupt request flag (ADIF)

The interrupt request flag (ADIF) is not cleared even if the analog input channel specification register (ADS) is changed.

Therefore, if an analog input pin is changed during A/D conversion, the A/D conversion result and ADIF flag for the pre-change analog input may be set just before the ADS register rewrite. Caution is therefore required since, at this time, when ADIF flag is read immediately after the ADS register rewrite, ADIF flag is set despite the fact A/D conversion for the post-change analog input has not ended.

When A/D conversion is stopped and then resumed, clear ADIF flag before the A/D conversion operation is resumed.

Figure 11-45. Timing of A/D Conversion End Interrupt Request Generation

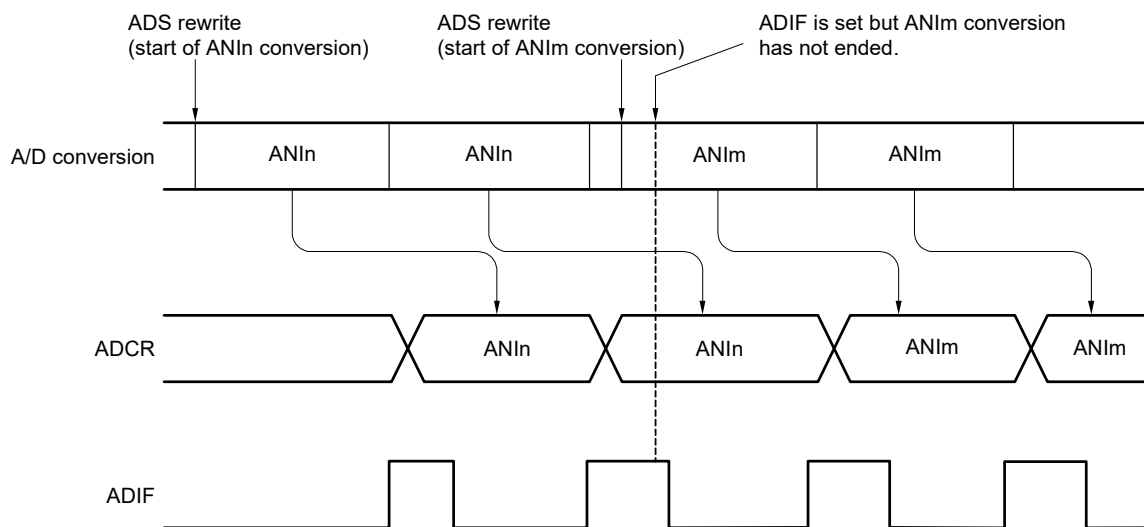

(8) Conversion results just after A/D conversion start

While in the software trigger mode or hardware trigger no-wait mode, the first A/D conversion value immediately after A/D conversion starts may not fall within the rating range if the ADCS bit is set to 1 within 1 μ s after the ADCE bit was set to 1. Take measures such as polling the A/D conversion end interrupt request (INTAD) and removing the first conversion result.

(9) A/D conversion result register (ADCR, ADCRH) read operation

When a write operation is performed to A/D converter mode register 0 (ADM0), analog input channel specification register (ADS), A/D port configuration register (ADPC), and port mode control register (PMCx), the contents of the ADCR and ADCRH registers may become undefined. Read the conversion result following conversion completion before writing to the ADM0, ADS, ADPC, or PMCx register. Using a timing other than the above may cause an incorrect conversion result to be read.

(10) Internal equivalent circuit

The equivalent circuit of the analog input block is shown below.

Figure 11-46. Internal Equivalent Circuit of ANIn Pin

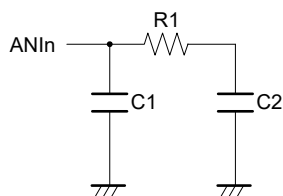

Table 11-4. Resistance and Capacitance Values of Equivalent Circuit (Reference Values)

AV_{REFP}, V_{DD}	ANIn Pins	R1 [k Ω]	C1 [pF]	C2 [pF]
$3.6\text{ V} \leq V_{DD} \leq 5.5\text{ V}$	ANI0 to ANI14	14	8	2.5
	ANI16 to ANI26	18	8	7.0
$2.7\text{ V} \leq V_{DD} \leq 3.6\text{ V}$	ANI0 to ANI14	39	8	2.5
	ANI16 to ANI26	53	8	7.0
$1.8\text{ V} \leq V_{DD} \leq 2.7\text{ V}$	ANI0 to ANI14	231	8	2.5
	ANI16 to ANI26	321	8	7.0
$1.6\text{ V} \leq V_{DD} < 2.7\text{ V}$	ANI0 to ANI14	632	8	2.5
	ANI16 to ANI26	902	8	7.0

Remark The resistance and capacitance values shown in **Table 11-4** are not guaranteed values.

(11) Starting the A/D converter

Start the A/D converter after the AV_{REFP} and V_{DD} voltages stabilize.

CHAPTER 12 SERIAL ARRAY UNIT

A single serial array unit has up to four serial channels. Each channel can achieve Simplified SPI (CSI^{Note}), UART, and simplified I²C communication.

Function assignment of each channel supported by the RL78/G13 is as shown below.

Note Although the CSI function is generally called SPI, it is also called CSI in this product, so it is referred to as such in this manual.

- 20, 24, 25-pin products

Unit	Channel	Used as Simplified SPI (CSI)	Used as UART	Used as Simplified I ² C
0	0	CSI00	UART0	IIC00
	1	–		–
	2	–	UART1	–
	3	CSI11		IIC11

- 30, 32-pin products

Unit	Channel	Used as Simplified SPI (CSI)	Used as UART	Used as Simplified I ² C
0	0	CSI00	UART0	IIC00
	1	–		–
	2	–	UART1	–
	3	CSI11		IIC11
1	0	CSI20	UART2 (supporting LIN-bus)	IIC20
	1	–		–

- 36, 40, 44-pin products

Unit	Channel	Used as Simplified SPI (CSI)	Used as UART	Used as Simplified I ² C
0	0	CSI00	UART0	IIC00
	1	–		–
	2	–	UART1	–
	3	CSI11		IIC11
1	0	CSI20	UART2 (supporting LIN-bus)	IIC20
	1	CSI21		IIC21

- 48, 52-pin products

Unit	Channel	Used as Simplified SPI (CSI)	Used as UART	Used as Simplified I ² C
0	0	CSI00	UART0	IIC00
	1	CSI01		IIC01
	2	–	UART1	–
	3	CSI11		IIC11
1	0	CSI20	UART2 (supporting LIN-bus)	IIC20
	1	CSI21		IIC21

- 64-pin products

Unit	Channel	Used as Simplified SPI (CSI)	Used as UART	Used as Simplified I ² C
0	0	CSI00	UART0	IIC00
	1	CSI01		IIC01
	2	CSI10	UART1	IIC10
	3	CSI11		IIC11
1	0	CSI20	UART2 (supporting LIN-bus)	IIC20
	1	CSI21		IIC21

- 80, 100, 128-pin products

Unit	Channel	Used as Simplified SPI (CSI)	Used as UART	Used as Simplified I ² C
0	0	CSI00	UART0	IIC00
	1	CSI01		IIC01
	2	CSI10	UART1	IIC10
	3	CSI11		IIC11
1	0	CSI20	UART2 (supporting LIN-bus)	IIC20
	1	CSI21		IIC21
	2	CSI30	UART3	IIC30
	3	CSI31		IIC31

When “UART0” is used for channels 0 and 1 of the unit 0, CSI00 and CSI01 cannot be used, but CSI10, UART1, or IIC10 can be used.

Caution Most of the following descriptions in this chapter use the units and channels of the 128-pin products as an example.

12.1 Functions of Serial Array Unit

Each serial interface supported by the RL78/G13 has the following features.

12.1.1 Simplified SPI (CSI00, CSI01, CSI10, CSI11, CSI20, CSI21, CSI30, CSI31)

Data is transmitted or received in synchronization with the serial clock (SCK) output from the master channel. Simplified SPI communication is clocked communication performed by using three communication lines: one for the serial clock (SCK), one for transmitting serial data (SO), one for receiving serial data (SI).

For details about the settings, see **12.5 Operation of Simplified SPI (CSI00, CSI01, CSI10, CSI11, CSI20, CSI21, CSI30, CSI31) Communication.**

[Data transmission/reception]

- Data length of 7 or 8 bits
- Phase control of transmit/receive data
- MSB/LSB first selectable

[Clock control]

- Master/slave selection
- Phase control of I/O clock
- Setting of transfer period by prescaler and internal counter of each channel
- Maximum transfer rate ^{Note}

During master communication: Max. $f_{CLK}/2$ (CSI00 only)

Max. $f_{CLK}/4$

During slave communication: Max. $f_{MCK}/6$

[Interrupt function]

- Transfer end interrupt/buffer empty interrupt

[Error detection flag]

- Overrun error

In addition, Simplified SPIs (CSIs) of following channels supports the SNOOZE mode. When SCK input is detected while in the STOP mode, the SNOOZE mode makes data reception that does not require the CPU possible. Only following Simplified SPIs (CSIs) can be specified for asynchronous reception.

- 20 to 64-pin products: CSI00
- 80 to 128-pin products: CSI00 and CSI20

Note Use the clocks within a range satisfying the SCK cycle time (t_{KCY}) characteristics. For details, see **CHAPTER 29 ELECTRICAL SPECIFICATIONS ($T_A = -40$ to $+85^\circ\text{C}$)** and **CHAPTER 30 ELECTRICAL SPECIFICATIONS (G: INDUSTRIAL APPLICATIONS $T_A = -40$ to $+105^\circ\text{C}$)**.

12.1.2 UART (UART0 to UART3)

This is a start-stop synchronization function using two lines: serial data transmission (TxD) and serial data reception (RxD) lines. By using these two communication lines, each data frame, which consist of a start bit, data, parity bit, and stop bit, is transferred asynchronously (using the internal baud rate) between the microcontroller and the other communication party. Full-duplex UART communication can be performed by using a channel dedicated to transmission (even-numbered channel) and a channel dedicated to reception (odd-numbered channel). The LIN-bus can be implemented by using timer array unit with an external interrupt (INTP0).

For details about the settings, see **12.6 Operation of UART (UART0 to UART3) Communication**.

[Data transmission/reception]

- Data length of 7, 8, or 9 bits **Note**
- Select the MSB/LSB first
- Level setting of transmit/receive data and select of reverse
- Parity bit appending and parity check functions
- Stop bit appending

[Interrupt function]

- Transfer end interrupt/buffer empty interrupt
- Error interrupt in case of framing error, parity error, or overrun error

[Error detection flag]

- Framing error, parity error, or overrun error

In addition, UARTs of following channels supports the SNOOZE mode. When the RxD input is detected while in the STOP mode, the SNOOZE mode makes data reception that does not require the CPU possible. Only the following UARTs can be specified for asynchronous reception.

- 20 to 64-pin products: UART0
- 80 to 128-pin products: UART0 and UART2

The LIN-bus is accepted in UART2 (0 and 1 channels of unit 1) (30-pin to 128-pin products only).

[LIN-bus functions]

- Wakeup signal detection
- Break field (BF) detection
- Sync field measurement, baud rate calculation

} Using the external interrupt (INTP0) and timer array unit

Note Only the following UARTs can be specified for the 9-bit data length.

- 20 to 64-pin products: UART0
- 80 to 128-pin products: UART0 and UART2

12.1.3 Simplified I²C (IIC00, IIC01, IIC10, IIC11, IIC20, IIC21, IIC30, IIC31)

This is a clocked communication function to communicate with two or more devices by using two lines: serial clock (SCL) and serial data (SDA). This simplified I²C is designed for single communication with a device such as EEPROM, flash memory, or A/D converter, and therefore, it functions only as a master.

Make sure by using software, as well as operating the control registers, that the AC specifications of the start and stop conditions are observed.

For details about the settings, see **12.8 Operation of Simplified I²C (IIC00, IIC01, IIC10, IIC11, IIC20, IIC21, IIC30, IIC31) Communication**.

[Data transmission/reception]

- Master transmission, master reception (only master function with a single master)
- ACK output function ^{Note} and ACK detection function
- Data length of 8 bits (When an address is transmitted, the address is specified by the higher 7 bits, and the least significant bit is used for R/W control.)
- Manual generation of start condition and stop condition

[Interrupt function]

- Transfer end interrupt

[Error detection flag]

- ACK error, or overrun error

* [Functions not supported by simplified I²C]

- Slave transmission, slave reception
- Arbitration loss detection function
- Wait detection functions

Note When receiving the last data, ACK will not be output if 0 is written to the SOEmn bit (serial output enable register m (SOEm)) and serial communication data output is stopped. See the processing flow in **12.8.3 (2)** for details.

Remarks 1. To use an I²C bus of full function, see **CHAPTER 13 SERIAL INTERFACE IICA**.

2. m: Unit number (m = 0, 1), n: Channel number (n = 0 to 3)

12.2 Configuration of Serial Array Unit

The serial array unit includes the following hardware.

Table 12-1. Configuration of Serial Array Unit

Item	Configuration
Shift register	8 bits or 9 bits ^{Note 1}
Buffer register	Lower 8 bits or 9 bits of serial data register mn (SDRmn) ^{Notes 1, 2}
Serial clock I/O	SCK00, SCK01, SCK10, SCK11, SCK20, SCK21, SCK30, SCK31 pins (for simplified SPI), SCL00, SCL01, SCL10, SCL11, SCL20, SCL21, SCL30, SCL31 pins (for simplified I ² C)
Serial data input	SI00, SI01, SI10, SI11, SI20, SI21, SI30, SI31 pins (for simplified SPI), RxD0, RxD1, RxD3 pins (for UART), RxD2 pin (for UART supporting LIN-bus)
Serial data output	SO00, SO01, SO10, SO11, SO20, SO21, SO30, SO31 pins (for simplified SPI), TxD0, TxD1, TxD3 pins (for UART), TxD2 pin (for UART supporting LIN-bus)
Serial data I/O	SDA00, SDA01, SDA10, SDA11, SDA20, SDA21, SDA30, SDA31 pins (for simplified I ² C)
Control registers	<p><Registers of unit setting block></p> <ul style="list-style-type: none"> ● Peripheral enable register 0 (PER0) ● Serial clock select register m (SPSm) ● Serial channel enable status register m (SEm) ● Serial channel start register m (SSm) ● Serial channel stop register m (STm) ● Serial output enable register m (SOEm) ● Serial output register m (SOM) ● Serial output level register m (SOLm) ● Serial standby control register m (SSCm) ● Input switch control register (ISC) ● Noise filter enable register 0 (NFEN0) <p><Registers of each channel></p> <ul style="list-style-type: none"> ● Serial data register mn (SDRmn) ● Serial mode register mn (SMRmn) ● Serial communication operation setting register mn (SCRmn) ● Serial status register mn (SSRmn) ● Serial flag clear trigger register mn (SIRmn) <ul style="list-style-type: none"> ● Port input mode registers 0, 1, 4, 5, 8, 14 (PIM0, PIM1, PIM4, PIM5, PIM8, PIM14) ● Port output mode registers 0, 1, 4, 5, 7 to 9, 14 (POM0, POM1, POM4, POM5, POM7 to POM9, POM14) ● Port mode control registers 0, 3, 14 (PMC0, PMC3, PMC14) ● Port mode registers 0, 1, 3 to 5, 7 to 9, 14 (PM0, PM1, PM3 to PM5, PM7 to PM9, PM14) ● Port registers 0, 1, 3 to 5, 7 to 9, 14 (P0, P1, P3 to P5, P7 to P9, P14)

(Notes and Remark are listed on the next page.)

- Notes**
1. The number of bits used as the shift register and buffer register differs depending on the unit and channel.
 - 20 to 64-pin products and mn = 00, 01: lower 9 bits
 - 80 to 128-pin products and mn = 00, 01, 10, 11: lower 9 bits
 - Other than above: lower 8 bits
 2. The lower 8 bits of serial data register mn (SDRmn) can be read or written as the following SFR, depending on the communication mode.
 - CSIp communication ... SIOp (CSIp data register)
 - UARTq reception ... RXDq (UARTq receive data register)
 - UARTq transmission ... TXDq (UARTq transmit data register)
 - IICr communication ... SIOr (IICr data register)

Remark m: Unit number (m = 0, 1), n: Channel number (n = 0 to 3), p: CSI number (p = 00, 01, 10, 11, 20, 21, 30, 31), q: UART number (q = 0 to 3), r: IIC number (r = 00, 01, 10, 11, 20, 21, 30, 31)

Figure 12-1 shows the block diagram of serial array unit 0.

Figure 12-1. Block Diagram of Serial Array Unit 0

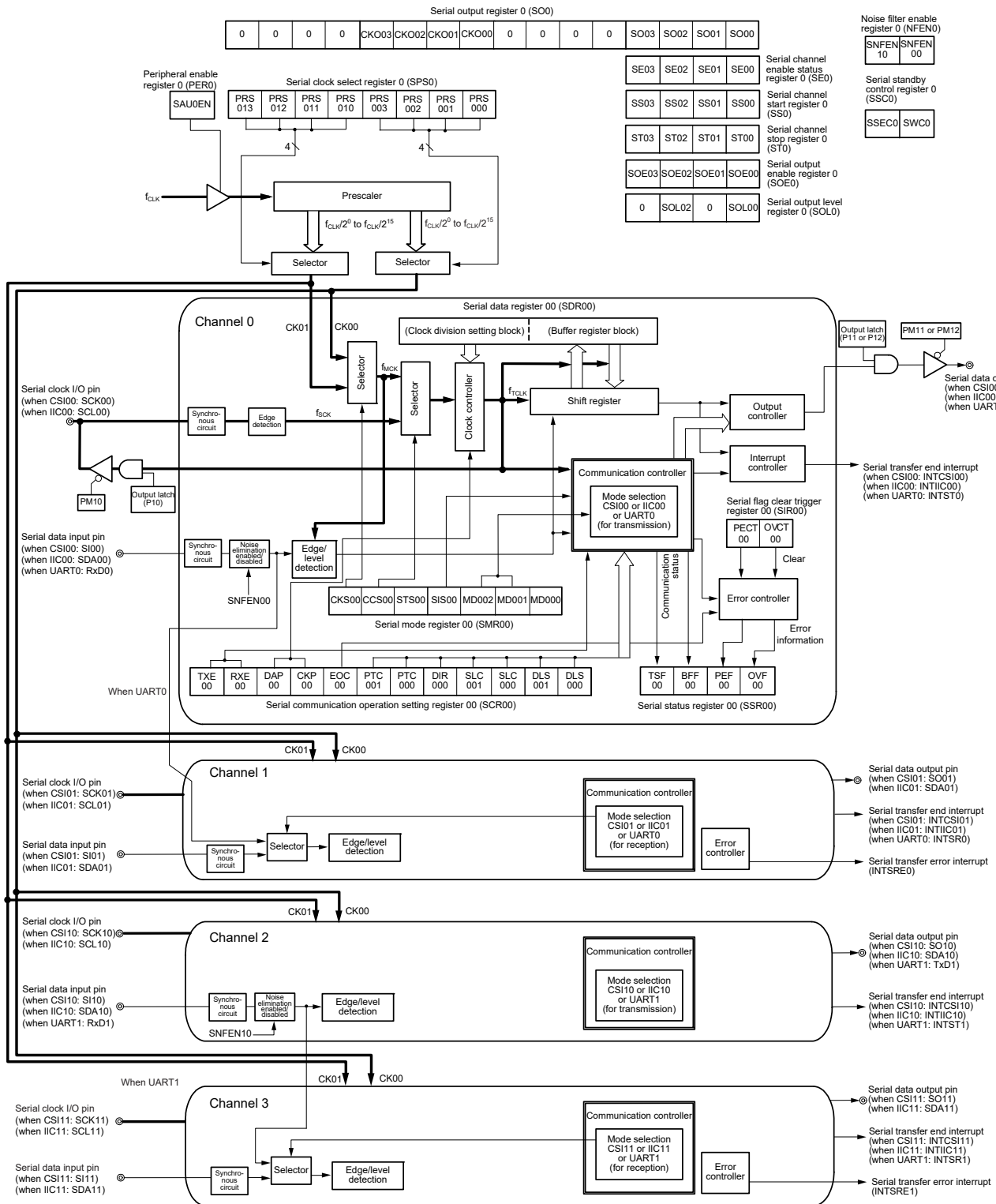
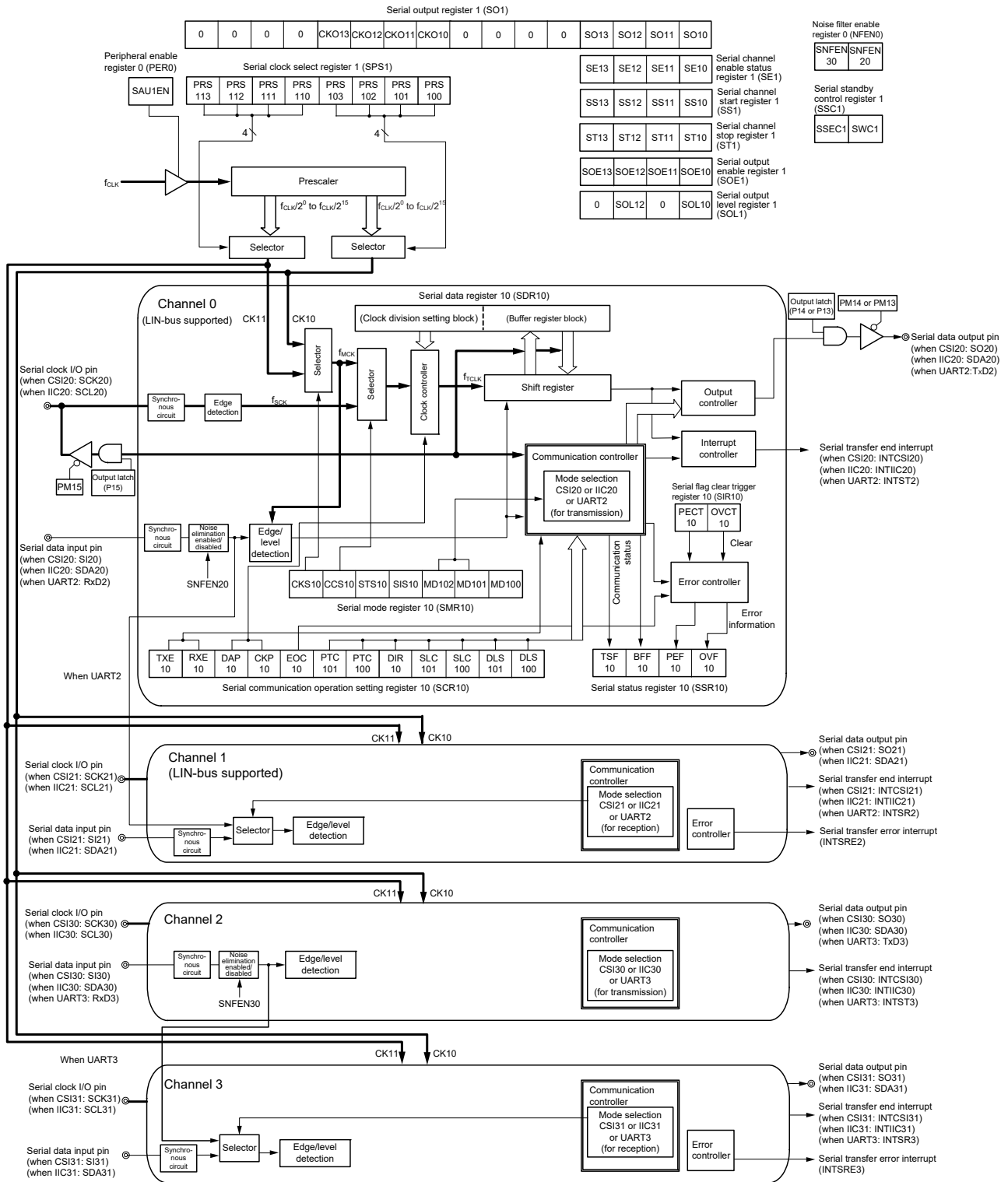

Figure 12-2 shows the block diagram of serial array unit 1.

Figure 12-2. Block Diagram of Serial Array Unit 1



12.2.1 Shift register

This is a 9-bit register that converts parallel data into serial data or vice versa.

In case of the UART communication of nine bits of data, nine bits (bits 0 to 8) are used ^{Note 1}.

During reception, it converts data input to the serial pin into parallel data.

When data is transmitted, the value set to this register is output as serial data from the serial output pin.

The shift register cannot be directly manipulated by program.

To read or write the shift register, use the lower 8/9 bits of serial data register mn (SDRmn).

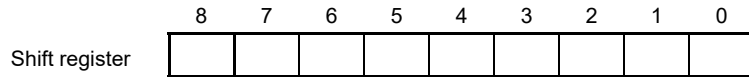

12.2.2 Lower 8/9 bits of the serial data register mn (SDRmn)

The SDRmn register is the transmit/receive data register (16 bits) of channel n. Bits 8 to 0 (lower 9 bits) ^{Note 1} or bits 7 to 0 (lower 8 bits) function as a transmit/receive buffer register, and bits 15 to 9 are used as a register that sets the division ratio of the operation clock (f_{MCK}).

When data is received, parallel data converted by the shift register is stored in the lower 8/9 bits. When data is to be transmitted, set transmit to be transferred to the shift register to the lower 8/9 bits.

The data stored in the lower 8/9 bits of this register is as follows, depending on the setting of bits 0 and 1 (DLSmn0, DLSmn1) of serial communication operation setting register mn (SCRmn), regardless of the output sequence of the data.

- 7-bit data length (stored in bits 0 to 6 of SDRmn register)
- 8-bit data length (stored in bits 0 to 7 of SDRmn register)
- 9-bit data length (stored in bits 0 to 8 of SDRmn register) ^{Note 1}

The SDRmn register can be read or written in 16-bit units.

The lower 8/9 bits of the SDRmn register can be read or written ^{Note 2} as the following SFR, depending on the communication mode.

- CSIp communication ... SIOp (CSIp data register)
- UARTq reception ... RXDq (UARTq receive data register)
- UARTq transmission ... TXDq (UARTq transmit data register)
- IICr communication ... SIOr (IICr data register)

Reset signal generation clears the SDRmn register to 0000H.

Notes 1. Only the following UARTs can be specified for the 9-bit data length.

- 20 to 64-pin products: UART0
- 80 to 128-pin products: UART0, UART2

2. When operation is stopped ($SEmn = 0$), do not rewrite SDRmn[7:0] by an 8-bit memory manipulation instruction (SDRmn[15:9] are all cleared to 0).

Remarks 1. After data is received, "0" is stored in bits 0 to 8 in bit portions that exceed the data length.

2. m: Unit number (m = 0, 1), n: Channel number (n = 0 to 3), p: CSI number (p = 00, 01, 10, 11, 20, 21, 30, 31), q: UART number (q = 0 to 3), r: IIC number (r = 00, 01, 10, 11, 20, 21, 30, 31)

Figure 12-3. Format of Serial Data Register mn (SDRmn) (mn = 00, 01, 10, 11)

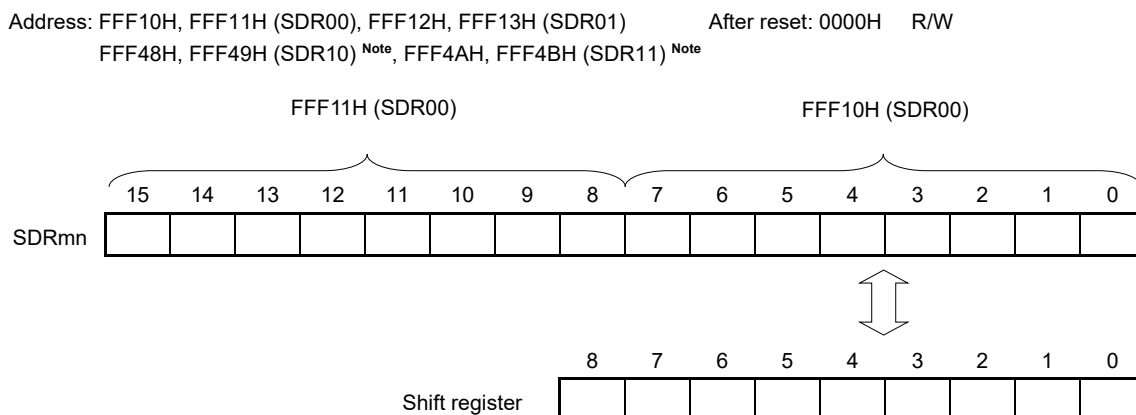

Note 80 to 128-pin products

Remark For the function of the higher 7 bits of the SDRmn register, see **12.3 Registers Controlling Serial Array Unit**.

Figure 12-4. Format of Serial Data Register mn (SDRmn) (mn = 02, 03, 10, 11, 12, 13)

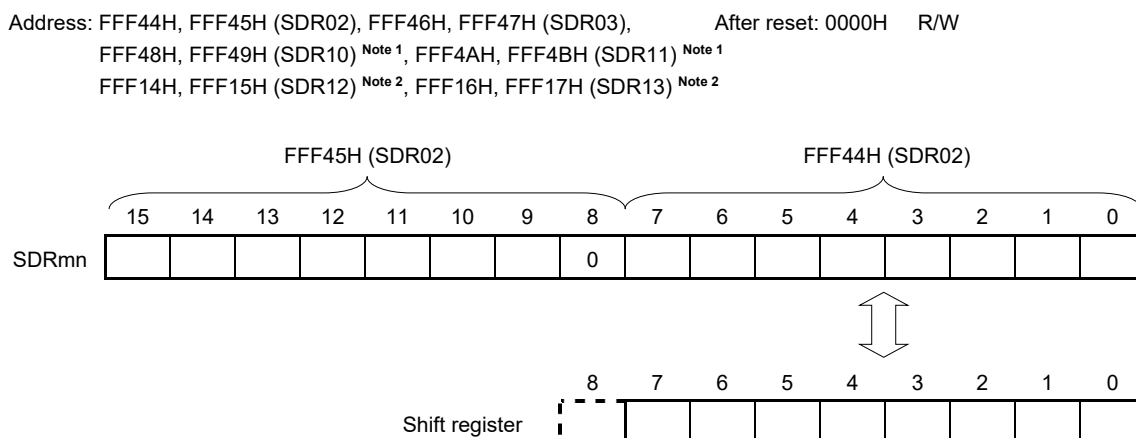

- Notes** 1. 20 to 64-pin products
- 2. 80 to 128-pin products

Caution Be sure to clear bit 8 to “0”.

Remark For the function of the higher 7 bits of the SDRmn register, see **12.3 Registers Controlling Serial Array Unit**.

12.3 Registers Controlling Serial Array Unit

The serial array unit is controlled by the following registers.

- Peripheral enable register 0 (PER0)
- Serial clock select register m (SPSm)
- Serial mode register mn (SMRmn)
- Serial communication operation setting register mn (SCRmn)
- Serial data register mn (SDRmn)
- Serial flag clear trigger register mn (SIRmn)
- Serial status register mn (SSRmn)
- Serial channel start register m (SSm)
- Serial channel stop register m (STm)
- Serial channel enable status register m (SEm)
- Serial output enable register m (SOEm)
- Serial output level register m (SOLm)
- Serial output register m (SOM)
- Serial standby control register m (SSCm)
- Input switch control register (ISC)
- Noise filter enable register 0 (NFEN0)
- Port input mode registers 0, 1, 4, 5, 8, 14 (PIM0, PIM1, PIM4, PIM5, PIM8, PIM14)
- Port output mode registers 0, 1, 4, 5, 7 to 9, 14 (POM0, POM1, POM4, POM5, POM7 to POM9, POM14)
- Port mode control registers 0, 3, 14 (PMC0, PMC3, PMC14)
- Port mode registers 0, 1, 3 to 5, 7 to 9, 14 (PM0, PM1, PM3 to PM5, PM7 to PM9, PM14)
- Port registers 0, 1, 3 to 5, 7 to 9, 14 (P0, P1, P3 to P5, P7 to P9, P14)

Remark m: Unit number (m = 0, 1), n: Channel number (n = 0 to 3)

12.3.1 Peripheral enable register 0 (PER0)

PER0 is used to enable or disable supplying the clock to the peripheral hardware. Clock supply to a hardware macro that is not used is stopped in order to reduce the power consumption and noise.

When serial array unit 0 is used, be sure to set bit 2 (SAU0EN) of this register to 1.

When serial array unit 1 is used, be sure to set bit 3 (SAU1EN) of this register to 1.

The PER0 register can be set by a 1-bit or 8-bit memory manipulation instruction.

Reset signal generation clears the PER0 register to 00H.

Figure 12-5. Format of Peripheral Enable Register 0 (PER0)

Address: F00F0H After reset: 00H R/W

Symbol	<7>	<6>	<5>	<4>	<3>	<2>	<1>	<0>
PER0	RTCEN	IICA1EN ^{Note 1}	ADCEN	IICA0EN ^{Note 2}	SAU1EN ^{Note 3}	SAU0EN	TAU1EN ^{Note 1}	TAU0EN

SAUmEN	Control of serial array unit m input clock supply
0	Stops supply of input clock. <ul style="list-style-type: none"> • SFR used by serial array unit m cannot be written. • Serial array unit m is in the reset status.
1	Enables input clock supply. <ul style="list-style-type: none"> • SFR used by serial array unit m can be read/written.

- Notes**
1. 80 to 128-pin products only.
 2. This is not provided in the 20-pin products.
 3. This is not provided in the 20, 24, and 25-pin products.

Cautions

1. When setting serial array unit m, be sure to first set the following registers with the SAUmEN bit set to 1. If SAUmEN = 0, control registers of serial array unit m become default values and writing to them is ignored (except for the input switch control register (ISC), noise filter enable register 0 (NFEN0), port input mode registers 0, 1, 4, 5, 8, 14 (PIM0, PIM1, PIM4, PIM5, PIM8, PIM14), port output mode registers 0, 1, 4, 5, 7 to 9, 14 (POM0, POM1, POM4, POM5, POM7 to POM9, POM14), port mode control registers 0, 3, 14 (PMC0, PMC3, PMC14), port mode registers 0, 1, 3 to 5, 7 to 9, 14 (PM0, PM1, PM3 to PM5, PM7 to PM9, PM14), and port registers 0, 1, 3 to 5, 7 to 9, 14 (P0, P1, P3 to P5, P7 to P9, P14)).

- Serial clock select register m (SPSm)
- Serial mode register mn (SMRmn)
- Serial communication operation setting register mn (SCRmn)
- Serial data register mn (SDRmn)
- Serial flag clear trigger register mn (SIRmn)
- Serial status register mn (SSRmn)
- Serial channel start register m (SSm)
- Serial channel stop register m (STm)
- Serial channel enable status register m (SEm)
- Serial output enable register m (SOEm)
- Serial output level register m (SOLm)
- Serial output register m (SOM)
- Serial standby control register m (SSCm)

2. Be sure to clear the following bits to 0.

20-pin products: bits 1, 3, 4, 6

24, 25-pin products: bits 1, 3, 6

30, 32, 36, 40, 44, 48, 52, 64-pin products: bits 1, 6

12.3.2 Serial clock select register m (SPSm)

The SPSm register is a 16-bit register that is used to select two types of operation clocks (CKm0, CKm1) that are commonly supplied to each channel. CKm1 is selected by bits 7 to 4 of the SPSm register, and CKm0 is selected by bits 3 to 0.

Rewriting the SPSm register is prohibited when the register is in operation (when SEMn = 1).

The SPSm register can be set by a 16-bit memory manipulation instruction.

The lower 8 bits of the SPSm register can be set with an 8-bit memory manipulation instruction with SPSmL.

Reset signal generation clears the SPSm register to 0000H.

Figure 12-6. Format of Serial Clock Select Register m (SPSm)

Address: F0126H, F0127H (SPS0), F0166H, F0167H (SPS1) ^{Note 1} After reset: 0000H R/W

Symbol	15	14	13	12	11	10	9	8	7	6	5	4	3	2	1	0
SPSm	0	0	0	0	0	0	0	0	PRS m13	PRS m12	PRS m11	PRS m10	PRS m03	PRS m02	PRS m01	PRS m00

PRS mk3	PRS mk2	PRS mk1	PRS mk0		Section of operation clock (CKmk) ^{Note 2}				
					f _{CLK} = 2 MHz	f _{CLK} = 5 MHz	f _{CLK} = 10 MHz	f _{CLK} = 20 MHz	f _{CLK} = 32 MHz
0	0	0	0	f _{CLK}	2 MHz	5 MHz	10 MHz	20 MHz	32 MHz
0	0	0	1	f _{CLK} /2	1 MHz	2.5 MHz	5 MHz	10 MHz	16 MHz
0	0	1	0	f _{CLK} /2 ²	500 kHz	1.25 MHz	2.5 MHz	5 MHz	8 MHz
0	0	1	1	f _{CLK} /2 ³	250 kHz	625 kHz	1.25 MHz	2.5 MHz	4 MHz
0	1	0	0	f _{CLK} /2 ⁴	125 kHz	313 kHz	625 kHz	1.25 MHz	2 MHz
0	1	0	1	f _{CLK} /2 ⁵	62.5 kHz	156 kHz	313 kHz	625 kHz	1 MHz
0	1	1	0	f _{CLK} /2 ⁶	31.3 kHz	78.1 kHz	156 kHz	313 kHz	500 kHz
0	1	1	1	f _{CLK} /2 ⁷	15.6 kHz	39.1 kHz	78.1 kHz	156 kHz	250 kHz
1	0	0	0	f _{CLK} /2 ⁸	7.81 kHz	19.5 kHz	39.1 kHz	78.1 kHz	125 kHz
1	0	0	1	f _{CLK} /2 ⁹	3.91 kHz	9.77 kHz	19.5 kHz	39.1 kHz	62.5 kHz
1	0	1	0	f _{CLK} /2 ¹⁰	1.95 kHz	4.88 kHz	9.77 kHz	19.5 kHz	31.3 kHz
1	0	1	1	f _{CLK} /2 ¹¹	977 Hz	2.44 kHz	4.88 kHz	9.77 kHz	15.6 kHz
1	1	0	0	f _{CLK} /2 ¹²	488 Hz	1.22 kHz	2.44 kHz	4.88 kHz	7.81 kHz
1	1	0	1	f _{CLK} /2 ¹³	244 Hz	610 Hz	1.22 kHz	2.44 kHz	3.91 kHz
1	1	1	0	f _{CLK} /2 ¹⁴	122 Hz	305 Hz	610 Hz	1.22 kHz	1.95 kHz
1	1	1	1	f _{CLK} /2 ¹⁵	61 Hz	153 kHz	305 Hz	610 Hz	977 Hz

Notes 1. 30 to 128-pin products only.

2. When changing the clock selected for f_{CLK} (by changing the system clock control register (CKC) value), do so after having stopped (serial channel stop register m (STm) = 000FH) the operation of the serial array unit (SAU).

Caution Be sure to clear bits 15 to 8 to “0”.

Remarks 1. f_{CLK}: CPU/peripheral hardware clock frequency

2. m: Unit number (m = 0, 1)

3. k = 0, 1

12.3.3 Serial mode register mn (SMRmn)

The SMRmn register is a register that sets an operation mode of channel n. It is also used to select an operation clock (f_{mck}), specify whether the serial clock (f_{sck}) may be input or not, set a start trigger, an operation mode (Simplified SPI (CSI), UART, or simplified I²C), and an interrupt source. This register is also used to invert the level of the receive data only in the UART mode.

Rewriting the SMRmn register is prohibited when the register is in operation (when SEMn = 1). However, the MDmn0 bit can be rewritten during operation.

The SMRmn register can be set by a 16-bit memory manipulation instruction.

Reset signal generation sets the SMRmn register to 0020H.

Figure 12-7. Format of Serial Mode Register mn (SMRmn) (1/2)

Address: F0110H, F0111H (SMR00) to F0116H, F0117H (SMR03), After reset: 0020H R/W
 F0150H, F0151H (SMR10) to F0156H, F0157H (SMR13) ^{Note 1}

Symbol	15	14	13	12	11	10	9	8	7	6	5	4	3	2	1	0
SMRmn	CKS mn	CCS mn	0	0	0	0	0	STS mn ^{Note 2}	0	SIS mn0 ^{Note 2}	1	0	0	MD mn2	MD mn1	MD mn0

CKS mn	Selection of operation clock (f _{mck}) of channel n
0	Operation clock CKm0 set by the SPSm register
1	Operation clock CKm1 set by the SPSm register
Operation clock (f _{mck}) is used by the edge detector. In addition, depending on the setting of the CCSmn bit and the higher 7 bits of the SDRmn register, a transfer clock (f _{tclk}) is generated.	

CCS mn	Selection of transfer clock (f _{tclk}) of channel n
0	Divided operation clock f _{mck} specified by the CKSmn bit
1	Clock input f _{sck} from the SCKp pin (slave transfer in Simplified SPI (CSI) mode)
Transfer clock f _{tclk} is used for the shift register, communication controller, output controller, interrupt controller, and error controller. When CCSmn = 0, the division ratio of operation clock (f _{mck}) is set by the higher 7 bits of the SDRmn register.	

STS mn ^{Note 2}	Selection of start trigger source
0	Only software trigger is valid (selected for Simplified SPI (CSI), UART transmission, and simplified I ² C).
1	Valid edge of the RxDq pin (selected for UART reception)
Transfer is started when the above source is satisfied after 1 is set to the SSm register.	

- Notes 1.** SMR00 to SMR03: All products
 SMR10, SMR11: 30 to 128-pin products
 SMR12, SMR13: 80 to 128-pin products

- 2.** The SMR01, SMR03, SMR11, and SMR13 registers only.

Caution Be sure to clear bits 13 to 9, 7, 4, and 3 (or bits 13 to 6, 4, and 3 for the SMR00, SMR02, SMR10, or SMR12 register) to “0”. Be sure to set bit 5 to “1”.

Remark m: Unit number (m = 0, 1), n: Channel number (n = 0 to 3), p: CSI number (p = 00, 01, 10, 11, 20, 21, 30, 31), q: UART number (q = 0 to 3), r: IIC number (r = 00, 01, 10, 11, 20, 21, 30, 31)

Figure 12-7. Format of Serial Mode Register mn (SMRmn) (2/2)

Address: F0110H, F0111H (SMR00) to F0116H, F0117H (SMR03), After reset: 0020H R/W
 F0150H, F0151H (SMR10) to F0156H, F0157H (SMR13) ^{Note 1}

Symbol	15	14	13	12	11	10	9	8	7	6	5	4	3	2	1	0
SMRmn	CKS mn	CCS mn	0	0	0	0	0	STS mn <small>Note 2</small>	0	SIS mn0 <small>Note 2</small>	1	0	0	MD mn2	MD mn1	MD mn0

SIS mn0 <small>Note 2</small>	Controls inversion of level of receive data of channel n in UART mode
0	Falling edge is detected as the start bit. The input communication data is captured as is.
1	Rising edge is detected as the start bit. The input communication data is inverted and captured.

MD mn2	MD mn1	Setting of operation mode of channel n
0	0	Simplified SPI (CSI) mode
0	1	UART mode
1	0	Simplified I ² C mode
1	1	Setting prohibited

MD mn0	Selection of interrupt source of channel n
0	Transfer end interrupt
1	Buffer empty interrupt (Occurs when data is transferred from the SDRmn register to the shift register.)
For successive transmission, the next transmit data is written by setting the MDmn0 bit to 1 when SDRmn data has run out.	

- Notes**
- SMR00 to SMR03: All products
 SMR10, SMR11: 30 to 128-pin products
 SMR12, SMR13: 80 to 128-pin products
 - The SMR01, SMR03, SMR11, and SMR13 registers only.

Caution Be sure to clear bits 13 to 9, 7, 4, and 3 (or bits 13 to 6, 4, and 3 for the SMR00, SMR02, SMR10, or SMR12 register) to “0”. Be sure to set bit 5 to “1”.

Remark m: Unit number (m = 0, 1), n: Channel number (n = 0 to 3), p: CSI number (p = 00, 01, 10, 11, 20, 21, 30, 31), q: UART number (q = 0 to 3), r: IIC number (r = 00, 01, 10, 11, 20, 21, 30, 31)

12.3.4 Serial communication operation setting register mn (SCRmn)

The SCRmn register is a communication operation setting register of channel n. It is used to set a data transmission/reception mode, phase of data and clock, whether an error signal is to be masked or not, parity bit, start bit, stop bit, and data length.

Rewriting the SCRmn register is prohibited when the register is in operation (when SEmn = 1).

The SCRmn register can be set by a 16-bit memory manipulation instruction.

Reset signal generation sets the SCRmn register to 0087H.

Figure 12-8. Format of Serial Communication Operation Setting Register mn (SCRmn) (1/2)

Address: F0118H, F0119H (SCR00) to F011EH, F011FH (SCR03), After reset: 0087H R/W
 F0158H, F0159H (SCR10) to F015EH, F015FH (SCR13) ^{Note 1}

Symbol	15	14	13	12	11	10	9	8	7	6	5	4	3	2	1	0
SCRmn	TXE mn	RXE mn	DAP mn	CKP mn	0	EOC mn	PTC mn1	PTC mn0	DIR mn	0	SLCm n1 ^{Note 2}	SLC mn0	0	1	DLSm n1 ^{Note 3}	DLS mn0

TXE mn	RXE mn	Setting of operation mode of channel n
0	0	Disable communication.
0	1	Reception only
1	0	Transmission only
1	1	Transmission/reception

DAP mn	CKP mn	Selection of data and clock phase in Simplified SPI (CSI) mode	Type
0	0		1
0	1		2
1	0		3
1	1		4

Be sure to set DAPmn, CKPmn = 0, 0 in the UART mode and simplified I²C mode.

EOC mn	Mask control of error interrupt signal (INTSREx (x = 0 to 3))
0	Disables generation of error interrupt INTSREx (INTSRx is generated).
1	Enables generation of error interrupt INTSREx (INTSRx is not generated if an error occurs).
Set EOCmn = 0 in the simplified SPI (CSI) mode, simplified I ² C mode, and during UART transmission ^{Note 4} .	

(Notes, Caution, and Remark are listed on the next page.)

- Notes**
1. SCR00 to SCR03: All products
SCR10, SCR11: 30 to 128-pin products
SCR12, SCR13: 80 to 128-pin products
 2. The SCR00, SCR02, SCR10, and SCR12 registers only.
 3. The SCR00 and SCR01 registers and SCR10 and SCR11 registers for 80 to 128-pins products only. Others are fixed to 1.
 4. When using CSImn not with EOCmn = 0, error interrupt INTSREn may be generated.

Caution Be sure to clear bits 3, 6, and 11 to “0” (Also clear bit 5 of the SCR01, SCR03, SCR11, or SCR13 register to 0). Be sure to set bit 2 to “1”.

Remark m: Unit number (m = 0, 1), n: Channel number (n = 0 to 3), p: CSI number (p = 00, 01, 10, 11, 20, 21, 30, 31)

Figure 12-8. Format of Serial Communication Operation Setting Register mn (SCRmn) (2/2)

Address: F0118H, F0119H (SCR00) to F011EH, F011FH (SCR03), After reset: 0087H R/W
 F0158H, F0159H (SCR10) to F015EH, F015FH (SCR13) ^{Note 1}

Symbol	15	14	13	12	11	10	9	8	7	6	5	4	3	2	1	0
SCRmn	TXE mn	RXE mn	DAP mn	CKP mn	0	EOC mn	PTC mn1	PTC mn0	DIR mn	0	SLCm n1 ^{Note 2}	SLC mn0	0	1	DLSm n1 ^{Note 3}	DLS mn0

PTC mn1	PTC mn0	Setting of parity bit in UART mode	
		Transmission	Reception
0	0	Does not output the parity bit.	
0	1	Outputs 0 parity ^{Note 4} .	
1	0	Outputs even parity.	
1	1	Outputs odd parity.	
Be sure to set PTCmn1, PTCmn0 = 0, 0 in the Simplified SPI (CSI) mode and simplified I ² C mode.			

DIR mn	Selection of data transfer sequence in Simplified SPI (CSI) and UART modes	
0	Inputs/outputs data with MSB first.	
1	Inputs/outputs data with LSB first.	
Be sure to clear DIRmn = 0 in the simplified I ² C mode.		

SLCm n1 ^{Note 2}	SLC mn0	Setting of stop bit in UART mode	
		0	0
0	1	Stop bit length = 1 bit	
1	0	Stop bit length = 2 bits (mn = 00, 02, 10, 12 only)	
1	1	Setting prohibited	
When the transfer end interrupt is selected, the interrupt is generated when all stop bits have been completely transferred. Set 1 bit (SLCmn1, SLCmn0 = 0, 1) during UART reception and in the simplified I ² C mode. Set no stop bit (SLCmn1, SLCmn0 = 0, 0) in the Simplified SPI (CSI) mode. Set 1 bit (SLCmn1, SLCmn0 = 0, 1) or 2 bits (SLCmn1, SLCmn0 = 1, 0) during UART transmission.			

DLSm n1 ^{Note 3}	DLS mn0	Setting of data length in Simplified SPI (CSI) and UART modes	
		0	1
1	0	7-bit data length (stored in bits 0 to 6 of the SDRmn register)	
1	1	8-bit data length (stored in bits 0 to 7 of the SDRmn register)	
Other than above		Setting prohibited	
Be sure to set DLSmn1, DLSmn0 = 1, 1 in the simplified I ² C mode.			

(Notes, Caution, and Remark are listed on the next page.)

- Notes**
1. SCR00 to SCR03: All products
SCR10, SCR11: 30 to 128-pin products
SCR12, SCR13: 80 to 128-pin products
 2. The SCR00, SCR02, SCR10, and SCR12 registers only.
 3. The SCR00 and SCR01 registers and SCR10 and SCR11 registers for 80 to 128-pins products only. Others are fixed to 1.
 4. 0 is always added regardless of the data contents.

Caution Be sure to clear bits 3, 6, and 11 to “0” (Also clear bit 5 of the SCR01, SCR03, SCR11, or SCR13 register to 0). Be sure to set bit 2 to “1”.

Remark m: Unit number (m = 0, 1), n: Channel number (n = 0 to 3), p: CSI number (p = 00, 01, 10, 11, 20, 21, 30, 31)

12.3.5 Serial data register mn (SDRmn)

The SDRmn register is the transmit/receive data register (16 bits) of channel n. Bits 8 to 0 (lower 9 bits) of SDR00, SDR01, SDR10 ^{Note 1}, SDR11 ^{Note 1} or bits 7 to 0 (lower 8 bits) of SDR02, SDR03, SDR10 ^{Note 2}, SDR11 ^{Note 2}, SDR12 and SDR13 function as a transmit/receive buffer register, and bits 15 to 9 (higher 7 bits) are used as a register that sets the division ratio of the operation clock (f_{MCK}).

If the CCSmn bit of serial mode register mn (SMRmn) is cleared to 0, the clock set by dividing the operation clock by bits 15 to 9 (higher 7 bits) of the SDRmn register is used as the transfer clock.

If the CCSmn bit of serial mode register mn (SMRmn) is set to 1, set bits 15 to 9 (upper 7 bits) of SDR00, SDR01, SDR10 ^{Note 1}, and SDR11 ^{Note 1} to 0000000B. The input clock f_{SCK} (slave transfer in Simplified SPI (CSI) mode) from the SCKp pin is used as the transfer clock.

The lower 8/9 bits of the SDRmn register function as a transmit/receive buffer register. During reception, the parallel data converted by the shift register is stored in the lower 8/9 bits, and during transmission, the data to be transmitted to the shift register is set to the lower 8/9 bits.

The SDRmn register can be read or written in 16-bit units.

However, the higher 7 bits can only be written or read when the operation is stopped ($SEmn = 0$). During operation ($SEmn = 1$), a value is written only to the lower 8/9 bits of the SDRmn register. When the SDRmn register is read during operation, the higher 7 bits are always read as 0.

Reset signal generation clears the SDRmn register to 0000H.

Figure 12-9. Format of Serial Data Register mn (SDRmn)

Address: FFF10H, FFF11H (SDR00), FFF12H, FFF13H (SDR01) After reset: 0000H R/W
 FFF48H, FFF49H (SDR10)^{Note 1}, FFF4AH, FFF4BH (SDR11)^{Note 1}

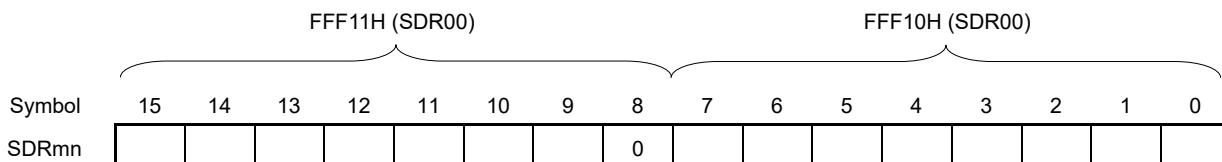

Address: FFF44H, FFF45H (SDR02), FFF46H, FFF47H (SDR03), After reset: 0000H R/W
 FFF48H, FFF49H (SDR10)^{Note 2}, FFF4AH, FFF4BH (SDR11)^{Note 2}
 FFF14H, FFF15H (SDR12)^{Note 1}, FFF16H, FFF17H (SDR13)^{Note 1}

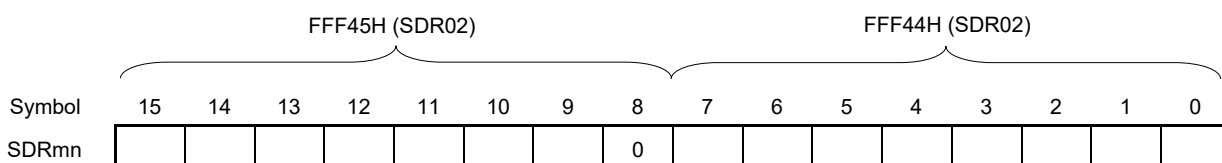

SDRmn[15:9]							Transfer clock setting by dividing the operation clock
0	0	0	0	0	0	0	fMCK/2
0	0	0	0	0	0	1	fMCK/4
0	0	0	0	0	1	0	fMCK/6
0	0	0	0	0	1	1	fMCK/8
•	•	•	•	•	•	•	•
•	•	•	•	•	•	•	•
•	•	•	•	•	•	•	•
1	1	1	1	1	1	0	fMCK/254
1	1	1	1	1	1	1	fMCK/256

- Notes**
1. 80 to 128-pin products
 2. 30 to 64-pin products

- Cautions**
1. Be sure to clear bit 8 of the SDR02, SDR03, SDR12, SDR13, and SDR10, and SDR11 of 30 to 64-pin products to “0”.
 2. Setting SDRmn[15:9] = (0000000B, 0000001B) is prohibited when UART is used.
 3. Setting SDRmn[15:9] = 0000000B is prohibited when simplified I²C is used. Set SDRmn[15:9] to 0000001B or greater.
 4. When operation is stopped (SEmn = 0), do not rewrite SDRmn[7:0] by an 8-bit memory manipulation instruction (SDRmn[15:9] are all cleared to 0).

- Remarks**
1. For the function of the lower 8/9 bits of the SDRmn register, see 12.2 Configuration of Serial Array Unit.
 2. m: Unit number (m = 0, 1), n: Channel number (n = 0 to 3)

12.3.6 Serial flag clear trigger register mn (SIRmn)

The SIRmn register is a trigger register that is used to clear each error flag of channel n.

When each bit (FECTmn, PECTmn, OVCTmn) of this register is set to 1, the corresponding bit (FEFmn, PEFmn, OVFMn) of serial status register mn is cleared to 0. Because the SIRmn register is a trigger register, it is cleared immediately when the corresponding bit of the SSRmn register is cleared.

The SIRmn register can be set by a 16-bit memory manipulation instruction.

The lower 8 bits of the SIRmn register can be set with an 8-bit memory manipulation instruction with SIRmnL.

Reset signal generation clears the SIRmn register to 0000H.

Figure 12-10. Format of Serial Flag Clear Trigger Register mn (SIRmn)

Address: F0108H, F0109H (SIR00) to F010EH, F010FH (SIR03), After reset: 0000H R/W
 F0148H, F0149H (SIR10) to F014EH, F014FH (SIR13) ^{Note 1}

Symbol	15	14	13	12	11	10	9	8	7	6	5	4	3	2	1	0
SIRmn	0	0	0	0	0	0	0	0	0	0	0	0	0	FECT mn ^{Note 2}	PEC Tmn	OVC Tmn

FEC Tmn	Clear trigger of framing error flag of channel n														
0	Not cleared														
1	Clears the FEFmn bit of the SSRmn register to 0.														

PEC Tmn	Clear trigger of parity error flag of channel n														
0	Not cleared														
1	Clears the PEFmn bit of the SSRmn register to 0.														

OVC Tmn	Clear trigger of overrun error flag of channel n														
0	Not cleared														
1	Clears the OVFMn bit of the SSRmn register to 0.														

- Notes 1.** SIR00 to SIR03: All products
 SIR10, SIR11: 30 to 128-pin products
 SIR12, SIR13: 80 to 128-pin products
- 2.** The SIR01, SIR03, SIR11, and SIR13 registers only.

Caution Be sure to clear bits 15 to 3 (or bits 15 to 2 for the SIR00, SIR02, SIR10, or SIR12 register) to “0”.

- Remarks 1.** m: Unit number (m = 0, 1), n: Channel number (n = 0 to 3)
- 2.** When the SIRmn register is read, 0000H is always read.

12.3.7 Serial status register mn (SSRmn)

The SSRmn register is a register that indicates the communication status and error occurrence status of channel n. The errors indicated by this register are a framing error, parity error, and overrun error. The SSRmn register can be read by a 16-bit memory manipulation instruction. The lower 8 bits of the SSRmn register can be set with an 8-bit memory manipulation instruction with SSRmnL. Reset signal generation clears the SSRmn register to 0000H.

Figure 12-11. Format of Serial Status Register mn (SSRmn) (1/2)

Address: F0100H, F0101H (SSR00) to F0106H, F0107H (SSR03), After reset: 0000H R
 F0140H, F0141H (SSR10) to F0146H, F0147H (SSR13) ^{Note 1}

Symbol	15	14	13	12	11	10	9	8	7	6	5	4	3	2	1	0
SSRmn	0	0	0	0	0	0	0	0	0	TSF mn	BFF mn	0	0	FEF mn <small>Note 2</small>	PEF mn	OVF mn

TSF mn	Communication status indication flag of channel n
0	Communication is stopped or suspended.
1	Communication is in progress.
<Clear conditions> <ul style="list-style-type: none"> • The STmn bit of the STm register is set to 1 (communication is stopped) or the SSmn bit of the SSm register is set to 1 (communication is suspended). • Communication ends. <Set condition> <ul style="list-style-type: none"> • Communication starts. 	

BFF mn	Buffer register status indication flag of channel n
0	Valid data is not stored in the SDRmn register.
1	Valid data is stored in the SDRmn register.
<Clear conditions> <ul style="list-style-type: none"> • Transferring transmit data from the SDRmn register to the shift register ends during transmission. • Reading receive data from the SDRmn register ends during reception. • The STmn bit of the STm register is set to 1 (communication is stopped) or the SSmn bit of the SSm register is set to 1 (communication is enabled). <Set conditions> <ul style="list-style-type: none"> • Transmit data is written to the SDRmn register while the TXEmn bit of the SCRmn register is set to 1 (transmission or transmission and reception mode in each communication mode). • Receive data is stored in the SDRmn register while the RXEmn bit of the SCRmn register is set to 1 (reception or transmission and reception mode in each communication mode). • A reception error occurs. 	

- Notes**
1. SSR00 to SSR03: All products
 SSR10, SSR11: 30 to 128-pin products
 SSR12, SSR13: 80 to 128-pin products
 2. The SSR01, SSR03, SSR11, and SSR13 registers only.

(Caution and Remark are listed on the next page.)

Caution When the simplified SPI (CSI) is handling reception in the SNOOZE mode (SWCm = 1), the BFFmn flag will not change.

Remark m: Unit number (m = 0, 1), n: Channel number (n = 0 to 3)

Figure 12-11. Format of Serial Status Register mn (SSRmn) (2/2)

Address: F0100H, F0101H (SSR00) to F0106H, F0107H (SSR03), After reset: 0000H R
 F0140H, F0141H (SSR10) to F0146H, F0147H (SSR13) ^{Note 1}

Symbol	15	14	13	12	11	10	9	8	7	6	5	4	3	2	1	0
SSRmn	0	0	0	0	0	0	0	0	0	TSF mn	BFF mn	0	0	FEF mn ^{Note 2}	PEF mn	OVF mn

FEF mn ^{Note 2}	Framing error detection flag of channel n
0	No error occurs.
1	An error occurs (during UART reception).
<Clear condition> <ul style="list-style-type: none"> • 1 is written to the FECTmn bit of the SIRmn register. <Set condition> <ul style="list-style-type: none"> • A stop bit is not detected when UART reception ends. 	

PEF mn	Parity/ACK error detection flag of channel n
0	No error occurs.
1	Parity error occurs (during UART reception) or ACK is not detected (during I ² C transmission).
<Clear condition> <ul style="list-style-type: none"> • 1 is written to the PECTmn bit of the SIRmn register. <Set condition> <ul style="list-style-type: none"> • The parity of the transmit data and the parity bit do not match when UART reception ends (parity error). • No ACK signal is returned from the slave channel at the ACK reception timing during I²C transmission (ACK is not detected). 	

OVF mn	Overrun error detection flag of channel n
0	No error occurs.
1	An error occurs
<Clear condition> <ul style="list-style-type: none"> • 1 is written to the OVCTmn bit of the SIRmn register. <Set condition> <ul style="list-style-type: none"> • Even though receive data is stored in the SDRmn register, that data is not read and transmit data or the next receive data is written while the RXEmn bit of the SCRmn register is set to 1 (reception or transmission and reception mode in each communication mode). • Transmit data is not ready for slave transmission or transmission and reception in Simplified SPI (CSI) mode. 	

(Notes, Cautions, and Remark are listed on the next page.)

- Notes**
1. SSR00 to SSR03: All products
 SSR10, SSR11: 30 to 128-pin products
 SSR12, SSR13: 80 to 128-pin products
 2. The SSR01, SSR03, SSR11, and SSR13 registers only.

- Cautions**
1. If data is written to the SDR_mn register when BFF_mn = 1, the transmit/receive data stored in the register is discarded and an overrun error (OVF_mn = 1) is detected.
 2. When the simplified SPI (CSI) is handling reception in the SNOOZE mode (SWC_m = 1), the OVF_mn flag will not change.

Remark m: Unit number (m = 0, 1), n: Channel number (n = 0 to 3)

12.3.8 Serial channel start register m (SS_m)

The SS_m register is a trigger register that is used to enable starting communication/count by each channel.

When 1 is written a bit of this register (SS_mn), the corresponding bit (SE_mn) of serial channel enable status register m (SE_m) is set to 1 (Operation is enabled). Because the SS_mn bit is a trigger bit, it is cleared immediately when SE_mn = 1.

The SS_m register can be set by a 16-bit memory manipulation instruction.

The lower 8 bits of the SS_m register can be set with an 1-bit or 8-bit memory manipulation instruction with SS_mL.

Reset signal generation clears the SS_m register to 0000H.

Figure 12-12. Format of Serial Channel Start Register m (SS_m)

Address: F0122H, F0123H (SS0) After reset: 0000H R/W

Symbol	15	14	13	12	11	10	9	8	7	6	5	4	3	2	1	0
SS0	0	0	0	0	0	0	0	0	0	0	0	0	SS03	SS02	SS01	SS00

Address: F0162H, F0163H (SS1) ^{Note 1} After reset: 0000H R/W

Symbol	15	14	13	12	11	10	9	8	7	6	5	4	3	2	1	0
SS1	0	0	0	0	0	0	0	0	0	0	0	0	SS13	SS12	SS11	SS10

SS _m n	Operation start trigger of channel n
0	No trigger operation
1	Sets the SE _m n bit to 1 and enters the communication wait status ^{Note 2} .

- Notes**
1. 30 to 128-pin products only
 2. If set the SS_mn = 1 to during a communication operation, will wait status to stop the communication. At this time, holding status value of control register and shift register, SCK_mn and SOM_n pins, and FEF_mn, PEF_mn, OVF_mn flags.

- Cautions**
1. Be sure to clear bits 15 to 4 of the SS0 register, bits 15 to 2 of the SS1 register for 30 to 64-pin products and bits 15 to 4 of the SS1 register for 80 to 128-pin products to “0”.
 2. For the UART reception, set the RXE_mn bit of SCR_mn register to 1, and then be sure to set SS_mn to 1 after 4 or more f_{MCK} clocks have elapsed.

- Remarks**
1. m: Unit number (m = 0, 1), n: Channel number (n = 0 to 3)
 2. When the SS_m register is read, 0000H is always read.

12.3.9 Serial channel stop register m (STm)

The STm register is a trigger register that is used to enable stopping communication/count by each channel.

When 1 is written a bit of this register (STmn), the corresponding bit (SEmn) of serial channel enable status register m (SEm) is cleared to 0 (operation is stopped). Because the STmn bit is a trigger bit, it is cleared immediately when SEmn = 0.

The STm register can set written by a 16-bit memory manipulation instruction.

The lower 8 bits of the STm register can be set with a 1-bit or 8-bit memory manipulation instruction with STmL.

Reset signal generation clears the STm register to 0000H.

Figure 12-13. Format of Serial Channel Stop Register m (STm)

Address: F0124H, F0125H (ST0) After reset: 0000H R/W

Symbol	15	14	13	12	11	10	9	8	7	6	5	4	3	2	1	0
ST0	0	0	0	0	0	0	0	0	0	0	0	0	ST03	ST02	ST01	ST00

Address: F0164H, F0165H (ST1) ^{Note 1} After reset: 0000H R/W

Symbol	15	14	13	12	11	10	9	8	7	6	5	4	3	2	1	0
ST1	0	0	0	0	0	0	0	0	0	0	0	0	ST13	ST12	ST11	ST10

STm n	Operation stop trigger of channel n															
0	No trigger operation															
1	Clears the SEmn bit to 0 and stops the communication operation ^{Note 2} .															

Notes 1. 30 to 128-pin products only

2. Holding status value of the control register and shift register, the SCKmn and SOMn pins, and FEFmn, PEFmn, OVFmn flags.

Caution Be sure to clear bits 15 to 4 of the ST0 register, bits 15 to 2 of the ST1 register for 30 to 64-pin products and bits 15 to 4 of the ST1 register for 80 to 128-pin products to “0”.

Remarks 1. m: Unit number (m = 0, 1), n: Channel number (n = 0 to 3)

2. When the STm register is read, 0000H is always read.

12.3.10 Serial channel enable status register m (SEm)

The SEm register indicates whether data transmission/reception operation of each channel is enabled or stopped.

When 1 is written a bit of serial channel start register m (SSm), the corresponding bit of this register is set to 1. When 1 is written a bit of serial channel stop register m (STm), the corresponding bit is cleared to 0.

Channel n that is enabled to operate cannot rewrite by software the value of the CKOmn bit (serial clock output of channel n) of serial output register m (SOM) to be described below, and a value reflected by a communication operation is output from the serial clock pin.

Channel n that stops operation can set the value of the CKOmn bit of the SOM register by software and output its value from the serial clock pin. In this way, any waveform, such as that of a start condition/stop condition, can be created by software.

The SEm register can be read by a 16-bit memory manipulation instruction.

The lower 8 bits of the SEm register can be set with a 1-bit or 8-bit memory manipulation instruction with SEmL.

Reset signal generation clears the SEm register to 0000H.

Figure 12-14. Format of Serial Channel Enable Status Register m (SEm)

Address: F0120H, F0121H (SE0) After reset: 0000H R

Symbol	15	14	13	12	11	10	9	8	7	6	5	4	3	2	1	0
SE0	0	0	0	0	0	0	0	0	0	0	0	0	SE03	SE02	SE01	SE00

Address: F0160H, F0161H (SE1) ^{Note} After reset: 0000H R

Symbol	15	14	13	12	11	10	9	8	7	6	5	4	3	2	1	0
SE1	0	0	0	0	0	0	0	0	0	0	0	0	SE13	SE12	SE11	SE10

SEm n	Indication of operation enable/stop status of channel n															
0	Operation stops															
1	Operation is enabled.															

Note 30 to 128-pin products only

Remark m: Unit number (m = 0, 1), n: Channel number (n = 0 to 3)

12.3.11 Serial output enable register m (SOEm)

The SOEm register is a register that is used to enable or stop output of the serial communication operation of each channel.

Channel n that enables serial output cannot rewrite by software the value of the SOMn bit of serial output register m (SOM) to be described below, and a value reflected by a communication operation is output from the serial data output pin.

For channel n, whose serial output is stopped, the SOMn bit value of the SOM register can be set by software, and that value can be output from the serial data output pin. In this way, any waveform of the start condition and stop condition can be created by software.

The SOEm register can be set by a 16-bit memory manipulation instruction.

The lower 8 bits of the SOEm register can be set with a 1-bit or 8-bit memory manipulation instruction with SOEmL. Reset signal generation clears the SOEm register to 0000H.

Figure 12-15. Format of Serial Output Enable Register m (SOEm)

Address: F012AH, F012BH (SOE0) After reset: 0000H R/W

Symbol	15	14	13	12	11	10	9	8	7	6	5	4	3	2	1	0
SOE0	0	0	0	0	0	0	0	0	0	0	0	0	SOE03	SOE02	SOE01	SOE00

Address: F016AH, F016BH (SOE1) ^{Note} After reset: 0000H R/W

Symbol	15	14	13	12	11	10	9	8	7	6	5	4	3	2	1	0
SOE1	0	0	0	0	0	0	0	0	0	0	0	0	SOE13	SOE12	SOE11	SOE10

SOEmn	Serial output enable/stop of channel n															
0	Stops output by serial communication operation.															
1	Enables output by serial communication operation.															

Note 30 to 128-pin products only

Caution Be sure to clear bits 15 to 4 of the SOE0 register, bits 15 to 2 of the SOE1 register for 30 to 64-pin products and bits 15 to 4 of the SOE1 register for 80 to 128-pin products to “0”.

Remark m: Unit number (m = 0, 1), n: Channel number (n = 0 to 3)

12.3.12 Serial output register m (SOM)

The SOM register is a buffer register for serial output of each channel.

The value of the SOMn bit of this register is output from the serial data output pin of channel n.

The value of the CKOm bit of this register is output from the serial clock output pin of channel n.

The SOMn bit of this register can be rewritten by software only when serial output is disabled (SOEmn = 0). When serial output is enabled (SOEmn = 1), rewriting by software is ignored, and the value of the register can be changed only by a serial communication operation.

The CKOm bit of this register can be rewritten by software only when the channel operation is stopped (SEmn = 0). While channel operation is enabled (SEmn = 1), rewriting by software is ignored, and the value of the CKOm bit can be changed only by a serial communication operation.

To use the pin for serial interface as a port function pin, set the corresponding CKOm and SOMn bits to “1”.

The SOM register can be set by a 16-bit memory manipulation instruction.

Reset signal generation clears the SOM register to 0F0FH.

Figure 12-16. Format of Serial Output Register m (SOM)

Address: F0128H, F0129H (SO0) After reset: 0F0FH R/W

Symbol	15	14	13	12	11	10	9	8	7	6	5	4	3	2	1	0
SO0	0	0	0	0	CKO 03	CKO 02	CKO 01	CKO 00	0	0	0	0	SO 03	SO 02	SO 01	SO 00

Address: F0168H, F0169H (SO1) ^{Note 1} After reset: 0F0FH ^{Note 2} R/W

Symbol	15	14	13	12	11	10	9	8	7	6	5	4	3	2	1	0
SO1	0	0	0	0	CKO 13	CKO 12	CKO 11	CKO 10	0	0	0	0	SO 13	SO 12	SO 11	SO 10

CKO mn	Serial clock output of channel n															
0	Serial clock output value is “0”.															
1	Serial clock output value is “1”.															

SO mn	Serial data output of channel n															
0	Serial data output value is “0”.															
1	Serial data output value is “1”.															

- Notes**
- 30 to 128-pin products only
 - The value after a reset is 0303H in cases of the 30- to 64-pin products with the ROM of no more than 64 Kbytes.

Caution Be sure to clear bits 15 to 12 and 7 to 4 of the SO0 register to “0”.
 Be sure to clear bits 15 to 10 and 7 to 2 of the SO1 register for the 30- to 64-pin products with the ROM of no more than 64 Kbytes and bits 15 to 12 and 7 to 4 of the SO1 register for 80 to 128-pin products to “0”.

Remark m: Unit number (m = 0, 1), n: Channel number (n = 0 to 3)

12.3.13 Serial output level register m (SOLm)

The SOLm register is a register that is used to set inversion of the data output level of each channel.

This register can be set only in the UART mode. Be sure to set 0 for corresponding bit in the Simplified SPI (CSI) mode and simplifies I²C mode.

Inverting channel n by using this register is reflected on pin output only when serial output is enabled (SOEmn = 1). When serial output is disabled (SOEmn = 0), the value of the SOmn bit is output as is.

Rewriting the SOLm register is prohibited when the register is in operation (when SEMn = 1).

The SOLm register can be set by a 16-bit memory manipulation instruction.

The lower 8 bits of the SOLm register can be set with an 8-bit memory manipulation instruction with SOLmL.

Reset signal generation clears the SOLm register to 0000H.

Figure 12-17. Format of Serial Output Level Register m (SOLm)

Address: F0134H, F0135H (SOL0) After reset: 0000H R/W

Symbol	15	14	13	12	11	10	9	8	7	6	5	4	3	2	1	0
SOL0	0	0	0	0	0	0	0	0	0	0	0	0	0	SOL 02	0	SOL 00

Address: F0174H, F0175H (SOL1) ^{Note} After reset: 0000H R/W

Symbol	15	14	13	12	11	10	9	8	7	6	5	4	3	2	1	0
SOL1	0	0	0	0	0	0	0	0	0	0	0	0	0	SOL 12	0	SOL 10

SOL mn	Selects inversion of the level of the transmit data of channel n in UART mode
0	Communication data is output as is.
1	Communication data is inverted and output.

Note 30 to 128-pin products only

Caution Be sure to clear bits 15 to 3, and 1 of the SOL0 register, bits 15 to 1 of the SOL1 register for 30 to 64-pin products, and bits 15 to 3, and 1 of the SOL1 register for 80 to 128-pin products to “0”.

(Remark is listed on the next page.)

Figure 12-18 shows examples in which the level of transmit data is reversed during UART transmission.

Figure 12-18. Examples of Reverse Transmit Data

(a) Non-reverse Output (SOLmn = 0)

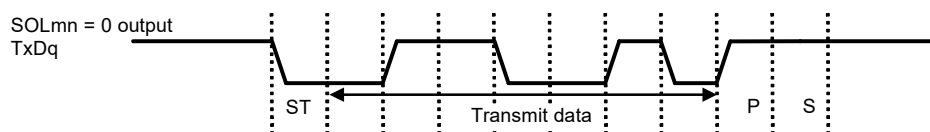

(b) Reverse Output (SOLmn = 1)

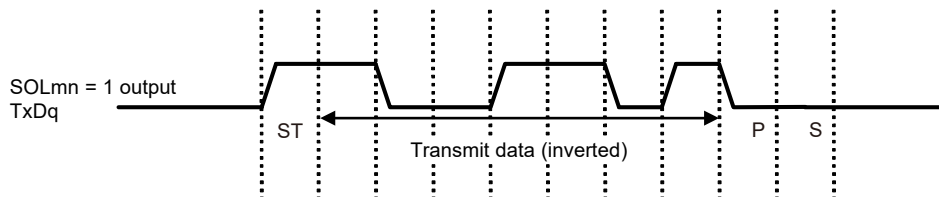

Remark m: Unit number (m = 0, 1), n: Channel number (n = 0, 2)

12.3.14 Serial standby control register m (SSCm)

The SSC0 register is used to control the startup of reception (the SNOOZE mode) while in the STOP mode when receiving CSI00 or UART0 serial data.

The SSC1^{Note} register is used to control the startup of reception (the SNOOZE mode) while in the STOP mode when receiving CSI20 or UART2 serial data.

The SSCm register can be set by a 16-bit memory manipulation instruction.

The lower 8 bits of the SSCm register can be set with an 8-bit memory manipulation instruction with SSCmL.

Reset signal generation clears the SSCm register to 0000H.

Caution The maximum transfer rate in the SNOOZE mode is as follows.

- When using CSI00, CSI20 : Up to 1 Mbps
- When using UART0, UART2 : 4800 bps only

Figure 12-19. Format of Serial Standby Control Register m (SSCm)

Address: F0138H, F0139H (SSC0), F0178H, F0179H (SSC1)^{Note} After reset: 0000H R/W

Symbol	15	14	13	12	11	10	9	8	7	6	5	4	3	2	1	0
SSCm	0	0	0	0	0	0	0	0	0	0	0	0	0	0	SS ECm	SWC m

SS ECm	Selection of whether to enable or disable the generation of communication error interrupts in the SNOOZE mode
0	Enable the generation of error interrupts (INTSRE0/INTSRE2).
1	Disable the generation of error interrupts (INTSRE0/INTSRE2).
<ul style="list-style-type: none"> ● The SSECm bit can be set to 1 or 0 only when both the SWCm and EOCmn bits are set to 1 during UART reception in the SNOOZE mode. In other cases, clear the SSECm bit to 0. ● Setting SSECm, SWCm = 1, 0 is prohibited. 	

SWC m	Setting of the SNOOZE mode
0	Do not use the SNOOZE mode function.
1	Use the SNOOZE mode function.
<ul style="list-style-type: none"> ● When there is a hardware trigger signal in the STOP mode, the STOP mode is exited, and simplified SPI (CSI) or UART reception is performed without operating the CPU (the SNOOZE mode). ● The SNOOZE mode function can only be specified when the high-speed on-chip oscillator clock is selected for the CPU/peripheral hardware clock (f_{CLK}). If any other clock is selected, specifying this mode is prohibited. ● Even when using SNOOZE mode, be sure to set the SWCm bit to 0 in normal operation mode and change it to 1 just before shifting to STOP mode. Also, be sure to change the SWCm bit to 0 after returning from STOP mode to normal operation mode. 	

Note 80 to 128-pin products only

Figure 12-20. Interrupt in UART Reception Operation in SNOOZE Mode

EOCm Bit	SSECm Bit	Reception Ended Successfully	Reception Ended in an Error
0	0	INTSRx is generated.	INTSRx is generated.
0	1	INTSRx is generated.	INTSRx is generated.
1	0	INTSRx is generated.	INTSREx is generated.
1	1	INTSRx is generated.	No interrupt is generated.

12.3.15 Input switch control register (ISC)

The ISC1 and ISC0 bits of the ISC register are used to realize a LIN-bus communication operation by UART2 in coordination with an external interrupt and the timer array unit.

When bit 0 is set to 1, the input signal of the serial data input (RxD2) pin is selected as an external interrupt (INTP0) that can be used to detect a wakeup signal.

When bit 1 is set to 1, the input signal of the serial data input (RxD2) pin is selected as a timer input, so that wake up signal can be detected, the low width of the break field, and the pulse width of the sync field can be measured by the timer.

The ISC register can be set by a 1-bit or 8-bit memory manipulation instruction.

Reset signal generation clears the ISC register to 00H.

Figure 12-21. Format of Input Switch Control Register (ISC)

Address: F0073H After reset: 00H R/W

Symbol	7	6	5	4	3	2	1	0
ISC	0	0	0	0	0	0	ISC1	ISC0

ISC1	Switching channel 7 input of timer array unit
0	30, 32, 36, 40, 44, 48, 52, 64, 80, 100, and 128-pin products: Uses the input signal of the TI07 pin as a timer input (normal operation). 20, 24, and 25-pin products: Do not use a timer input signal for channel 7.
1	Input signal of the RxD2 pin is used as timer input (detects the wakeup signal and measures the low width of the break field and the pulse width of the sync field). Setting is prohibited in the 20, 24, and 25-pin products.

ISC0	Switching external interrupt (INTP0) input
0	Uses the input signal of the INTP0 pin as an external interrupt (normal operation).
1	Uses the input signal of the RxD2 pin as an external interrupt (wakeup signal detection).

Caution Be sure to clear bits 7 to 2 to “0”.

12.3.16 Noise filter enable register 0 (NFEN0)

The NFEN0 register is used to set whether the noise filter can be used for the input signal from the serial data input pin to each channel.

Disable the noise filter of the pin used for Simplified SPI (CSI) or simplified I²C communication, by clearing the corresponding bit of this register to 0.

Enable the noise filter of the pin used for UART communication, by setting the corresponding bit of this register to 1.

When the noise filter is enabled, after synchronization is performed with the operation clock (f_{MCK}) of the target channel, 2-clock match detection is performed. When the noise filter is disabled, only synchronization is performed with the operation clock (f_{MCK}) of the target channel.

The NFEN0 register can be set by a 1-bit or 8-bit memory manipulation instruction.

Reset signal generation clears the NFEN0 register to 00H.

Figure 12-22. Format of Noise Filter Enable Register 0 (NFEN0)

Address: F0070H After reset: 00H R/W

Symbol	7	6	5	4	3	2	1	0
NFEN0	0	SNFEN30	0	SNFEN20	0	SNFEN10	0	SNFEN00

SNFEN30	Use of noise filter of RxD3 pin
0	Noise filter OFF
1	Noise filter ON
Set SNFEN30 to 1 to use the RxD3 pin. Clear SNFEN30 to 0 to use the other than RxD3 pin.	

SNFEN20	Use of noise filter of RxD2 pin
0	Noise filter OFF
1	Noise filter ON
Set SNFEN20 to 1 to use the RxD2 pin. Clear SNFEN20 to 0 to use the other than RxD2 pin.	

SNFEN10	Use of noise filter of RxD1 pin
0	Noise filter OFF
1	Noise filter ON
Set the SNFEN10 bit to 1 to use the RxD1 pin. Clear the SNFEN10 bit to 0 to use the other than RxD1 pin.	

SNFEN00	Use of noise filter of RxD0 pin
0	Noise filter OFF
1	Noise filter ON
Set the SNFEN00 bit to 1 to use the RxD0 pin. Clear the SNFEN00 bit to 0 to use the other than RxD0 pin.	

Caution Be sure to clear bits 7 to 3, and 1 for 20 to 25-pin products, bits 7 to 5, 3, and 1 for 30 to 64-pin products and bits 7, 5, 3, and 1 for 80 to 128-pin products to “0”.

12.3.17 Registers controlling port functions of serial input/output pins

Using the serial array unit requires setting of the registers that control the port functions multiplexed on the target channel (port mode register (PMxx), port register (Pxx), port input mode register (PIMxx), port output mode register (POMxx), port mode control register (PMCxx)).

For details, see **4.3.1 Port mode registers (PMxx)**, **4.3.2 Port registers (Pxx)**, **4.3.4 Port input mode registers (PIMxx)**, **4.3.5 Port output mode registers (POMxx)**, and **4.3.6 Port mode control registers (PMCxx)**.

Specifically, using a port pin with a multiplexed serial data or serial clock output function (e.g. P02/ANI17/SO10/TxD1) for serial data or serial clock output, requires setting the corresponding bits in the port mode control register (PMCxx) and port mode register (PMxx) to 0, and the corresponding bit in the port register (Pxx) to 1.

When using the port pin in N-ch open-drain output (VDD tolerance ^{Note 1}/EVDD tolerance ^{Note 2}) mode, set the corresponding bit in the port output mode register (POMxx) to 1. When connecting an external device operating on a different potential (1.8 V, 2.5 V or 3 V), see **4.4.5 Handling different potential (1.8 V, 2.5 V, 3 V) by using I/O buffers**.

Example: When P02/ANI17/SO10/TxD1 is to be used for serial data output

- Set the PMC02 bit of port mode control register 0 to 0.
- Set the PM02 bit of port mode register 0 to 0.
- Set the P02 bit of port register 0 to 1.

Specifically, using a port pin with a multiplexed serial data or serial clock input function (e.g. P03/ANI16/SI10/RxD1/SDA10) for serial data or serial clock input, requires setting the corresponding bit in the port mode register (PMxx) to 1, and the corresponding bit in the port mode control register (PMCxx) to 0. In this case, the corresponding bit in the port register (Pxx) can be set to 0 or 1.

When the TTL input buffer is selected, set the corresponding bit in the port input mode register (PIMxx) to 1. When connecting an external device operating on a different potential (1.8 V, 2.5 V or 3 V), see **4.4.5 Handling different potential (1.8 V, 2.5 V, 3 V) by using I/O buffers**.

Example: When P03/ANI16/SI10/RxD1/SDA10 is to be used for serial data input

- Set the PMC03 bit of port mode control register 0 to 0.
- Set the PM03 bit of port mode register 0 to 1.
- Set the P03 bit of port register 0 to 0 or 1.

- Notes**
1. 20 to 52-pin products
 2. 64 to 128-pin products

12.4 Operation Stop Mode

Each serial interface of serial array unit has the operation stop mode.

In this mode, serial communication cannot be executed, thus reducing the power consumption.

In addition, the pin for serial interface can be used as port function pins in this mode.

12.4.1 Stopping the operation by units

The stopping of the operation by units is set by using peripheral enable register 0 (PER0).

The PER0 register is used to enable or disable supplying the clock to the peripheral hardware. Clock supply to a hardware macro that is not used is stopped in order to reduce the power consumption and noise.

To stop the operation of serial array unit 0, set bit 2 (SAU0EN) to 0.

To stop the operation of serial array unit 1, set bit 3 (SAU1EN) to 0.

Figure 12-23. Peripheral Enable Register 0 (PER0) Setting When Stopping the Operation by Units

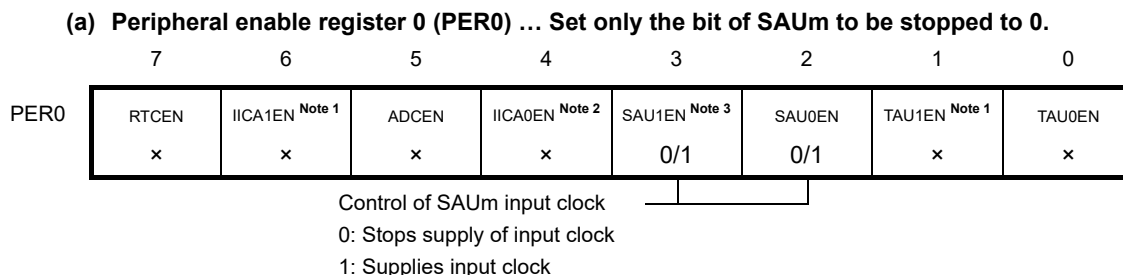

Notes 1. 80, 100, and 128-pin products only.

2. This is not provided in the 20-pin products.

3. This is not provided in the 20, 24, and 25-pin products.

Cautions 1. If SAUmEN = 0, writing to a control register of serial array unit m is ignored, and, even if the register is read, only the default value is read

Note that this does not apply to the following registers.

- Input switch control register (ISC)
- Noise filter enable register 0 (NFEN0)
- Port input mode registers 0, 1, 4, 5, 8, 14 (PIM0, PIM1, PIM4, PIM5, PIM8, PIM14)
- Port output mode registers 0, 1, 4, 5, 7 to 9, 14 (POM0, POM1, POM4, POM5, POM7 to POM9, POM14)
- Port mode control registers 0, 3, 14 (PMC0, PMC3, PMC14)
- Port mode registers 0, 1, 3 to 5, 7 to 9, 14 (PM0, PM1, PM3 to PM5, PM7 to PM9, PM14)
- Port registers 0, 1, 3 to 5, 7 to 9, 14 (P0, P1, P3 to P5, P7 to P9, P14)

2. Be sure to clear the following bits to 0.

20-pin products: bits 1, 3, 4, 6

24, 25-pin products: bits 1, 3, 6

30, 32, 36, 40, 44, 48, 52, 64-pin products: bits 1, 6

Remark ×: Bits not used with serial array units (depending on the settings of other peripheral functions)
0/1: Set to 0 or 1 depending on the usage of the user

12.4.2 Stopping the operation by channels

The stopping of the operation by channels is set using each of the following registers.

Figure 12-24. Each Register Setting When Stopping the Operation by Channels

(a) Serial channel stop register m (STm) ... This register is a trigger register that is used to enable stopping communication/count by each channel.

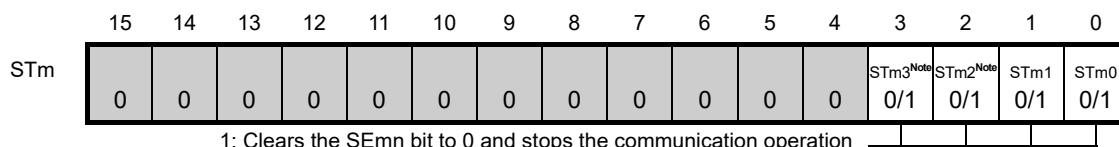

* Because the ST_mn bit is a trigger bit, it is cleared immediately when SE_mn = 0.

(b) Serial channel enable status register m (SEm) ... This register indicates whether data transmission/reception operation of each channel is enabled or stopped.

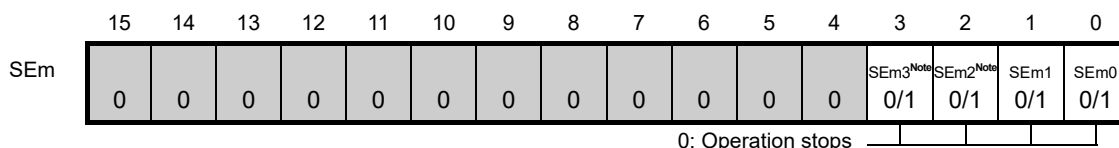

* The SE_m register is a read-only status register, whose operation is stopped by using the ST_m register. With a channel whose operation is stopped, the value of the CKO_mn bit of the SO_m register can be set by software.

(c) Serial output enable register m (SOEm) ... This register is a register that is used to enable or stop output of the serial communication operation of each channel.

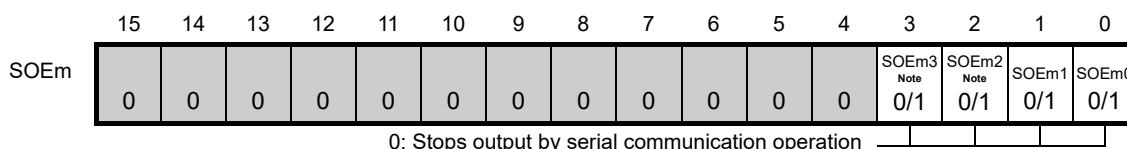

* For channel n, whose serial output is stopped, the SO_mn bit value of the SO_m register can be set by software.

(d) Serial output register m (SOm) ... This register is a buffer register for serial output of each channel.

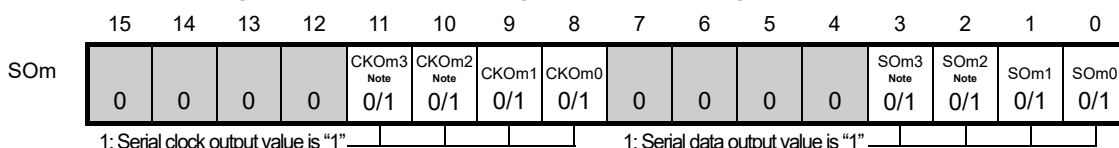

* When using pins corresponding to each channel as port function pins, set the corresponding CKO_mn, SO_mn bits to "1".

Note For serial array unit 1, 80 to 128-pin products only.

- Remarks 1.** m: Unit number (m = 0, 1), n: Channel number (n = 0 to 3)
 2. : Setting disabled (fixed by hardware), 0/1: Set to 0 or 1 depending on the usage of the user

12.5 Operation of Simplified SPI (CSI00, CSI01, CSI10, CSI11, CSI20, CSI21, CSI30, CSI31) Communication

This is a clocked communication function that uses three lines: serial clock (SCK) and serial data (SI and SO) lines.

[Data transmission/reception]

- Data length of 7 or 8 bits
- Phase control of transmit/receive data
- MSB/LSB first selectable

[Clock control]

- Master/slave selection
- Phase control of I/O clock
- Setting of transfer period by prescaler and internal counter of each channel
- Maximum transfer rate ^{Note}

During master communication: Max. $f_{CLK}/2$ (CSI00 only)

Max. $f_{CLK}/4$

During slave communication: Max. $f_{MCK}/6$

[Interrupt function]

- Transfer end interrupt/buffer empty interrupt

[Error detection flag]

- Overrun error

In addition, Simplified SPIs (CSIs) of following channels supports the SNOOZE mode. When SCK input is detected while in the STOP mode, the SNOOZE mode makes data reception that does not require the CPU possible. Only following Simplified SPIs (CSIs) can be specified.

- 20 to 64-pin products: CSI00
- 80 to 128-pin products: CSI00 and CSI20

Note Use the clocks within a range satisfying the SCK cycle time (t_{CKCY}) characteristics. For details, see **CHAPTER 29 ELECTRICAL SPECIFICATIONS ($T_A = -40$ to $+85^\circ\text{C}$)** and **CHAPTER 30 ELECTRICAL SPECIFICATIONS (G: INDUSTRIAL APPLICATIONS $T_A = -40$ to $+105^\circ\text{C}$)**.

The channels supporting Simplified SPI (CSI00, CSI01, CSI10, CSI11, CSI20, CSI21, CSI30, CSI31) are channels 0 to 3 of SAU0 and channels 0 to 3 of SAU1.

- 20, 24, 25-pin products

Unit	Channel	Used as Simplified SPI (CSI)	Used as UART	Used as Simplified I ² C
0	0	CSI00	UART0	IIC00
	1	–		–
	2	–	UART1	–
	3	CSI11		IIC11

- 30, 32-pin products

Unit	Channel	Used as Simplified SPI (CSI)	Used as UART	Used as Simplified I ² C
0	0	CSI00	UART0	IIC00
	1	–		–
	2	–	UART1	–
	3	CSI11		IIC11
1	0	CSI20	UART2 (supporting LIN-bus)	IIC20
	1	–		–

- 36, 40, 44-pin products

Unit	Channel	Used as Simplified SPI (CSI)	Used as UART	Used as Simplified I ² C
0	0	CSI00	UART0	IIC00
	1	–		–
	2	–	UART1	–
	3	CSI11		IIC11
1	0	CSI20	UART2 (supporting LIN-bus)	IIC20
	1	CSI21		IIC21

- 48, 52-pin products

Unit	Channel	Used as Simplified SPI (CSI)	Used as UART	Used as Simplified I ² C
0	0	CSI00	UART0	IIC00
	1	CSI01		IIC01
	2	–	UART1	–
	3	CSI11		IIC11
1	0	CSI20	UART2 (supporting LIN-bus)	IIC20
	1	CSI21		IIC21

- 64-pin products

Unit	Channel	Used as Simplified SPI (CSI)	Used as UART	Used as Simplified I ² C
0	0	CSI00	UART0	IIC00
	1	CSI01		IIC01
	2	CSI10	UART1	IIC10
	3	CSI11		IIC11
1	0	CSI20	UART2 (supporting LIN-bus)	IIC20
	1	CSI21		IIC21

- 80, 100, 128-pin products

Unit	Channel	Used as Simplified SPI (CSI)	Used as UART	Used as Simplified I ² C
0	0	CSI00	UART0	IIC00
	1	CSI01		IIC01
	2	CSI10	UART1	IIC10
	3	CSI11		IIC11
1	0	CSI20	UART2 (supporting LIN-bus)	IIC20
	1	CSI21		IIC21
	2	CSI30	UART3	IIC30
	3	CSI31		IIC31

Simplified SPI (CSI00, CSI01, CSI10, CSI11, CSI20, CSI21, CSI30, CSI31) performs the following seven types of communication operations.

- Master transmission (See 12.5.1.)
- Master reception (See 12.5.2.)
- Master transmission/reception (See 12.5.3.)
- Slave transmission (See 12.5.4.)
- Slave reception (See 12.5.5.)
- Slave transmission/reception (See 12.5.6.)
- SNOOZE mode function (See 12.5.7.)

12.5.1 Master transmission

Master transmission is that the RL78 microcontroller outputs a transfer clock and transmits data to another device.

Simplified SPI	CSI00	CSI01	CSI10	CSI11	CSI20	CSI21	CSI30	CSI31
Target channel	Channel 0 of SAU0	Channel 1 of SAU0	Channel 2 of SAU0	Channel 3 of SAU0	Channel 0 of SAU1	Channel 1 of SAU1	Channel 2 of SAU1	Channel 3 of SAU1
Pins used	SCK00, SO00	SCK01, SO01	SCK10, SO10	SCK11, SO11	SCK20, SO20	SCK21, SO21	SCK30, SO30	SCK31, SO31
Interrupt	INTCSI00	INTCSI01	INTCSI10	INTCSI11	INTCSI20	INTCSI21	INTCSI30	INTCSI31
Error detection flag	None							
Transfer data length	7 or 8 bits							
Transfer rate ^{Note}	Max. $f_{CLK}/2$ [Hz] (CSI00 only), $f_{CLK}/4$ [Hz] Min. $f_{CLK}/(2 \times 2^{15} \times 128)$ [Hz] f_{CLK} : System clock frequency							
Data phase	Selectable by the DAPmn bit of the SCRmn register <ul style="list-style-type: none"> • DAPmn = 0: Data output starts from the start of the operation of the serial clock. • DAPmn = 1: Data output starts half a clock before the start of the serial clock operation. 							
Clock phase	Selectable by the CKPmn bit of the SCRmn register <ul style="list-style-type: none"> • CKPmn = 0: Non-reverse • CKPmn = 1: Reverse 							
Data direction	MSB or LSB first							

Note Use this operation within a range that satisfies the conditions above and the peripheral functions characteristics in the electrical specifications (see **CHAPTER 29 ELECTRICAL SPECIFICATIONS (T_A = -40 to +85°C)** and **CHAPTER 30 ELECTRICAL SPECIFICATIONS (G: INDUSTRIAL APPLICATIONS T_A = -40 to +105°C)**).

Remark m: Unit number (m = 0, 1), n: Channel number (n = 0 to 3), mn = 00 to 03, 10 to 13

(1) Register setting

Figure 12-25. Example of Contents of Registers for Master Transmission of Simplified SPI (CSI00, CSI01, CSI10, CSI11, CSI20, CSI21, CSI30, CSI31) (1/2)

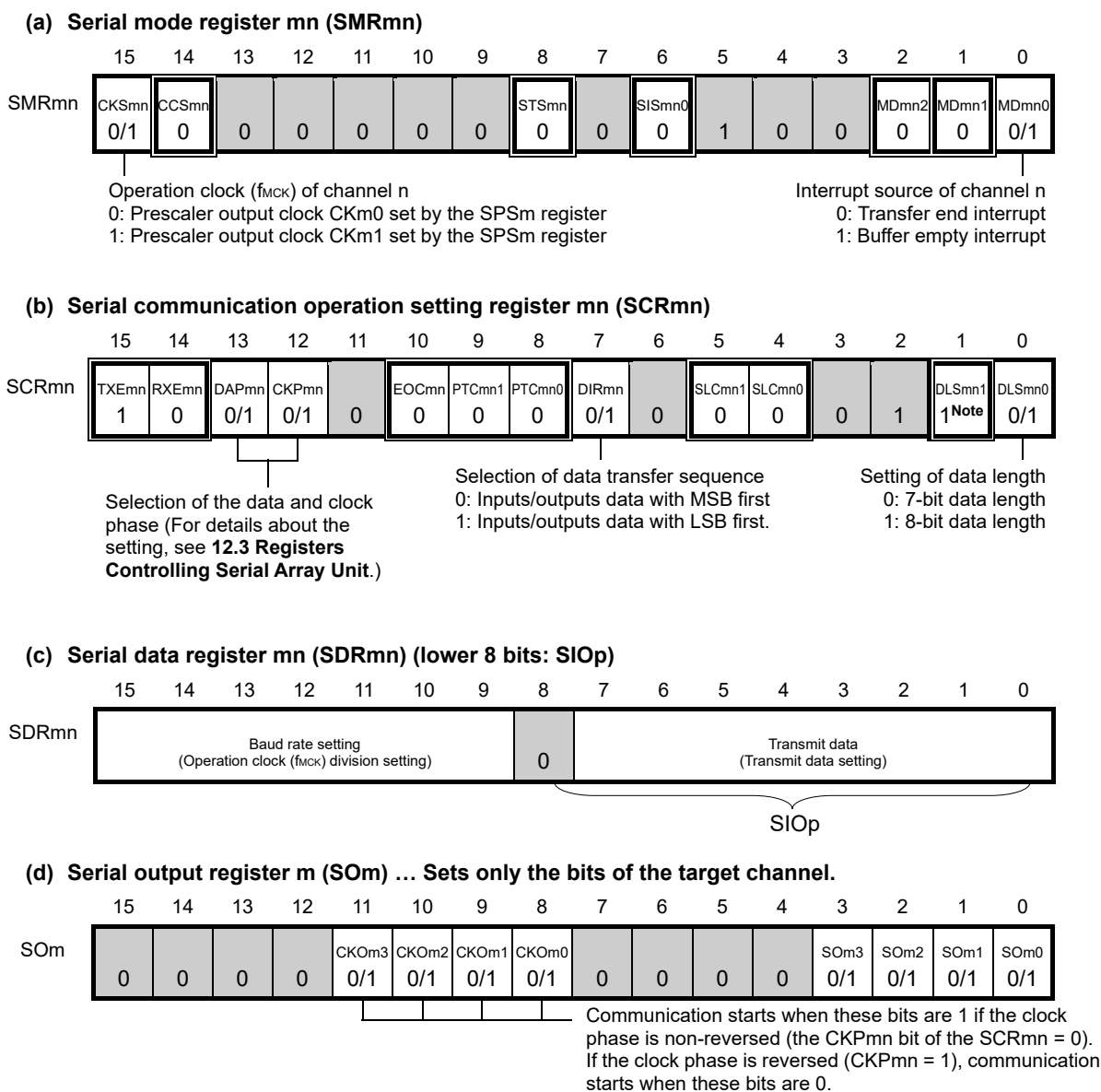

Note Only provided for the SCR00 and SCR01 registers and the SCR10 and SCR11 registers of an 80- to 128-pin product. This bit is fixed to 1 for the other registers.

Remarks 1. m: Unit number (m = 0, 1), n: Channel number (n = 0 to 3), p: CSI number (p = 00, 01, 10, 11, 20, 21, 30, 31), mn = 00 to 03, 10 to 13
 2. □: Setting is fixed in the simplified SPI (CSI) master transmission mode, ■: Setting disabled (set to the initial value)
 0/1: Set to 0 or 1 depending on the usage of the user

Figure 12-25. Example of Contents of Registers for Master Transmission of Simplified SPI (CSI00, CSI01, CSI10, CSI11, CSI20, CSI21) (2/2)

(e) **Serial output enable register m (SOEm) ... Sets only the bits of the target channel to 1.**

	15	14	13	12	11	10	9	8	7	6	5	4	3	2	1	0
SOEm	0	0	0	0	0	0	0	0	0	0	0	0	SOEm3	SOEm2	SOEm1	SOEm0
	0	0	0	0	0	0	0	0	0	0	0	0	0/1	0/1	0/1	0/1

(f) **Serial channel start register m (SSm) ... Sets only the bits of the target channel to 1.**

	15	14	13	12	11	10	9	8	7	6	5	4	3	2	1	0
SSm	0	0	0	0	0	0	0	0	0	0	0	0	SSm3	SSm2	SSm1	SSm0
	0	0	0	0	0	0	0	0	0	0	0	0	0/1	0/1	0/1	0/1

- Remarks**
1. m: Unit number (m = 0, 1)
 2. : Setting disabled (set to the initial value)
0/1: Set to 0 or 1 depending on the usage of the user

(2) Operation procedure

Figure 12-26. Initial Setting Procedure for Master Transmission

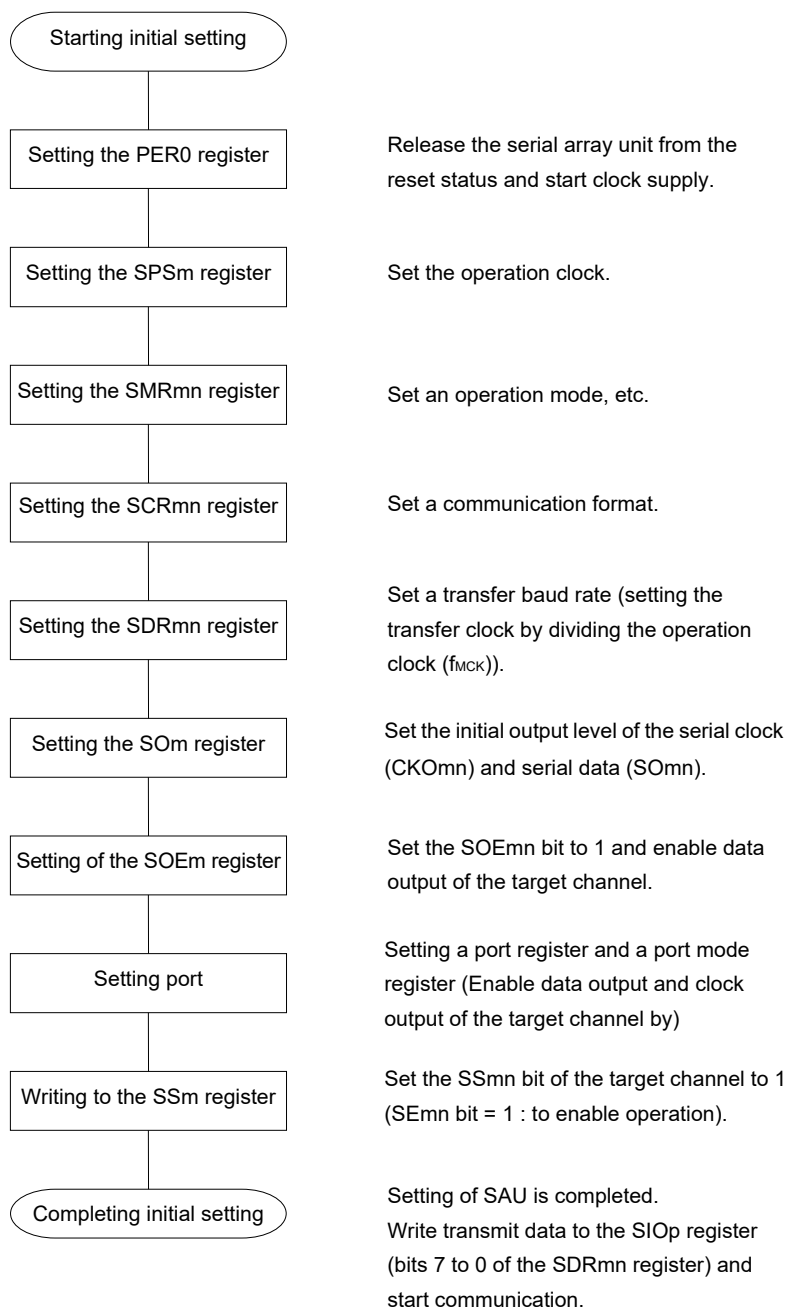

Figure 12-27. Procedure for Stopping Master Transmission

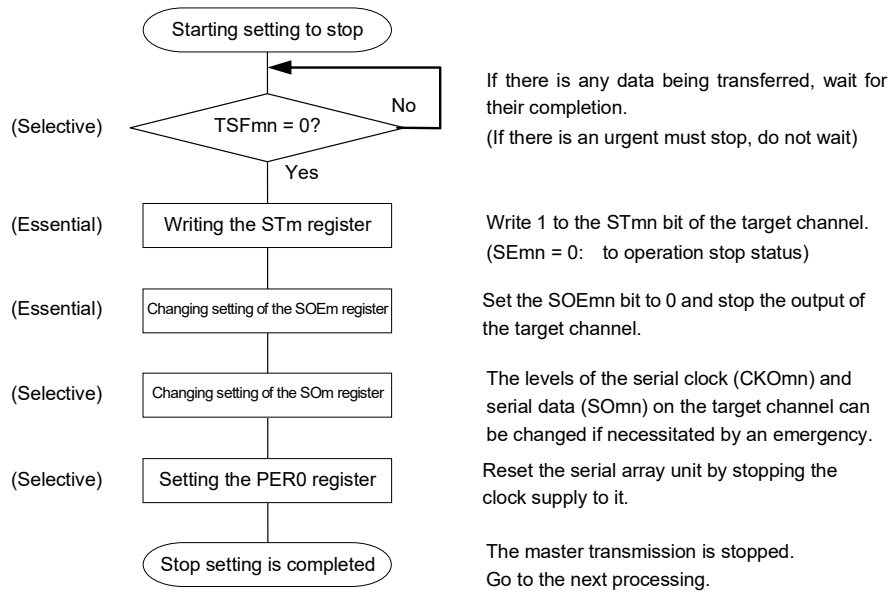
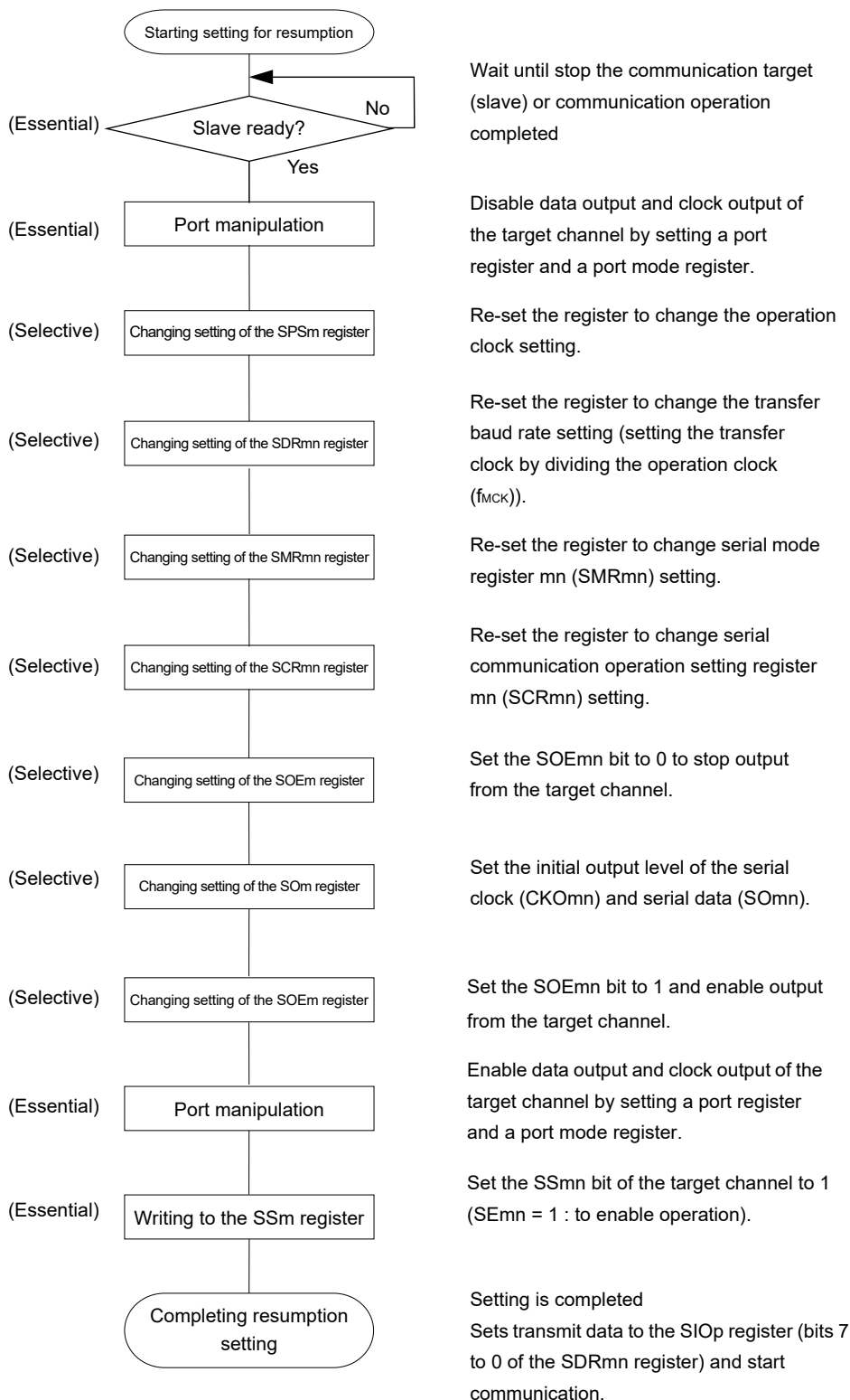

Figure 12-28. Procedure for Resuming Master Transmission



Remark If PER0 is rewritten while stopping the master transmission and the clock supply is stopped, wait until the transmission target (slave) stops or transmission finishes, and then perform initialization instead of restarting the transmission.

(3) Processing flow (in single-transmission mode)

Figure 12-29. Timing Chart of Master Transmission (in Single-Transmission Mode)
 (Type 1: DAPmn = 0, CKPmn = 0)

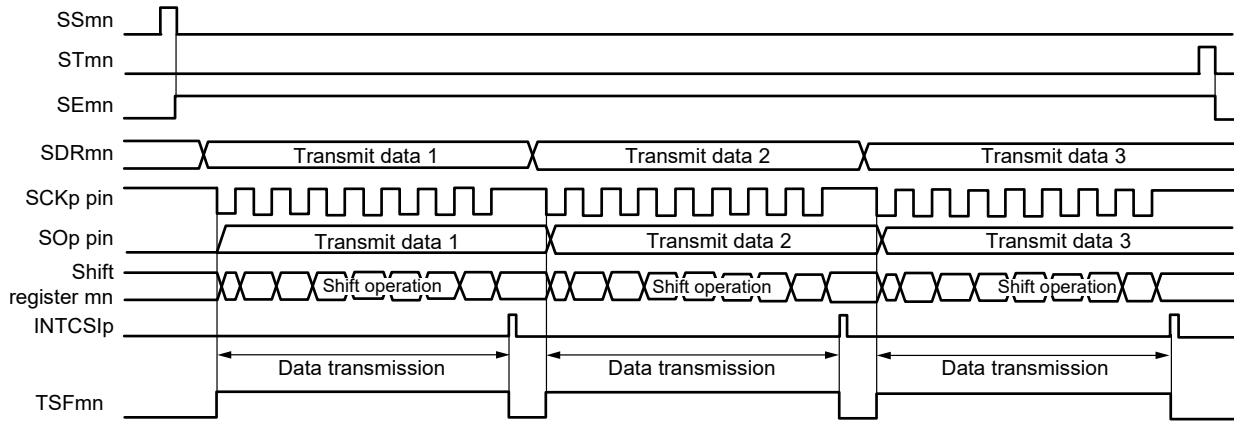

Remark m: Unit number (m = 0, 1), n: Channel number (n = 0 to 3), p: CSI number (p = 00, 01, 10, 11, 20, 21, 30, 31), mn = 00 to 03, 10 to 13

Figure 12-30. Flowchart of Master Transmission (in Single-Transmission Mode)

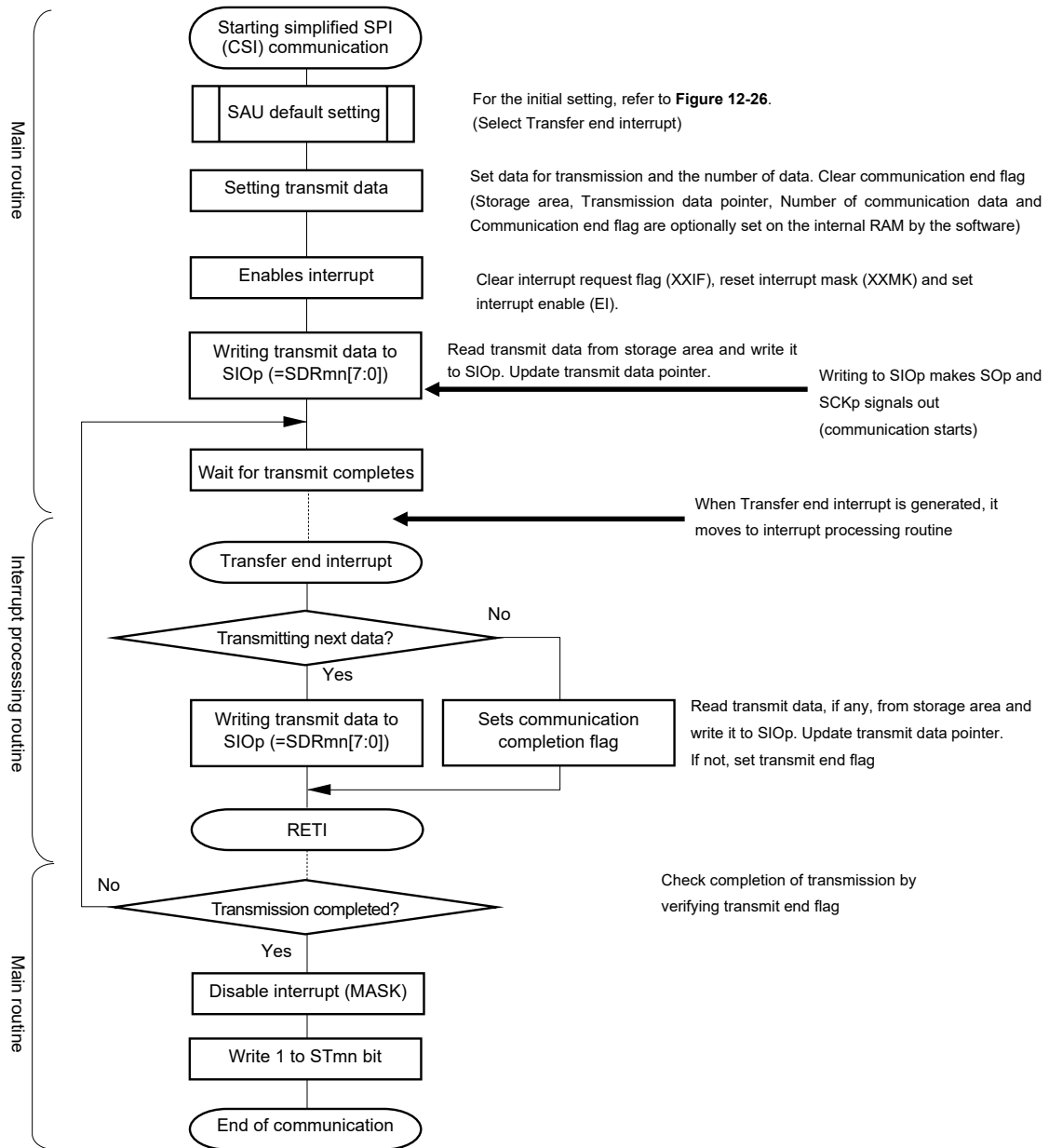

(4) Processing flow (in continuous transmission mode)

Figure 12-31. Timing Chart of Master Transmission (in Continuous Transmission Mode)
(Type 1: DAPmn = 0, CKPmn = 0)

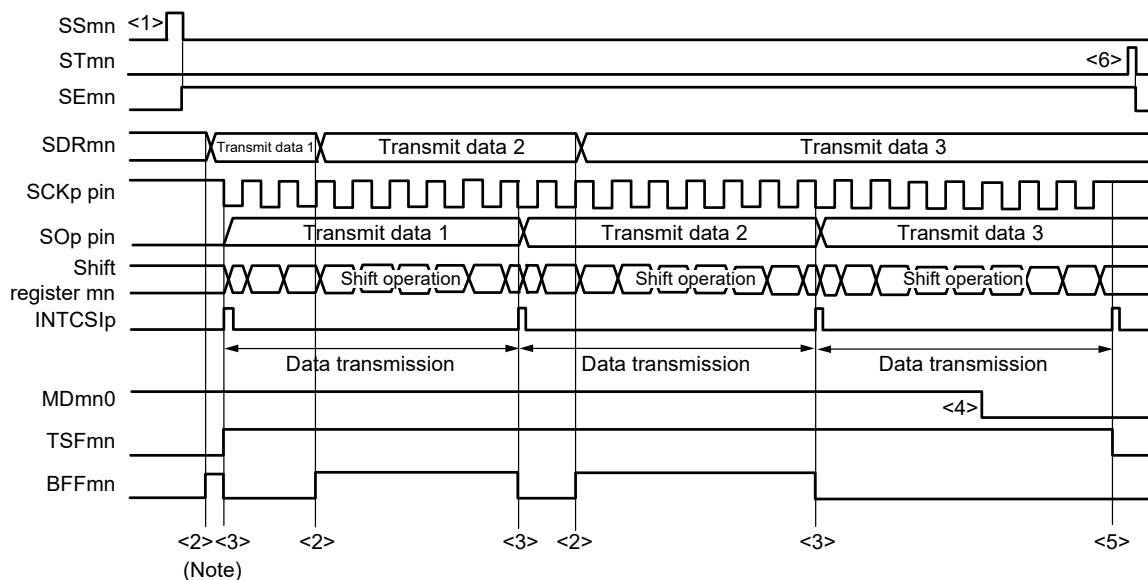

Note If transmit data is written to the SDRmn register while the BFFmn bit of serial status register mn (SSRmn) is 1 (valid data is stored in serial data register mn (SDRmn)), the transmit data is overwritten.

Caution The MDmn0 bit of serial mode register mn (SMRmn) can be rewritten even during operation. However, rewrite it before transfer of the last bit is started, so that it will be rewritten before the transfer end interrupt of the last transmit data.

Remark m: Unit number (m = 0, 1), n: Channel number (n = 0 to 3), p: CSI number (p = 00, 01, 10, 11, 20, 21, 30, 31), mn = 00 to 03, 10 to 13

Figure 12-32. Flowchart of Master Transmission (in Continuous Transmission Mode)

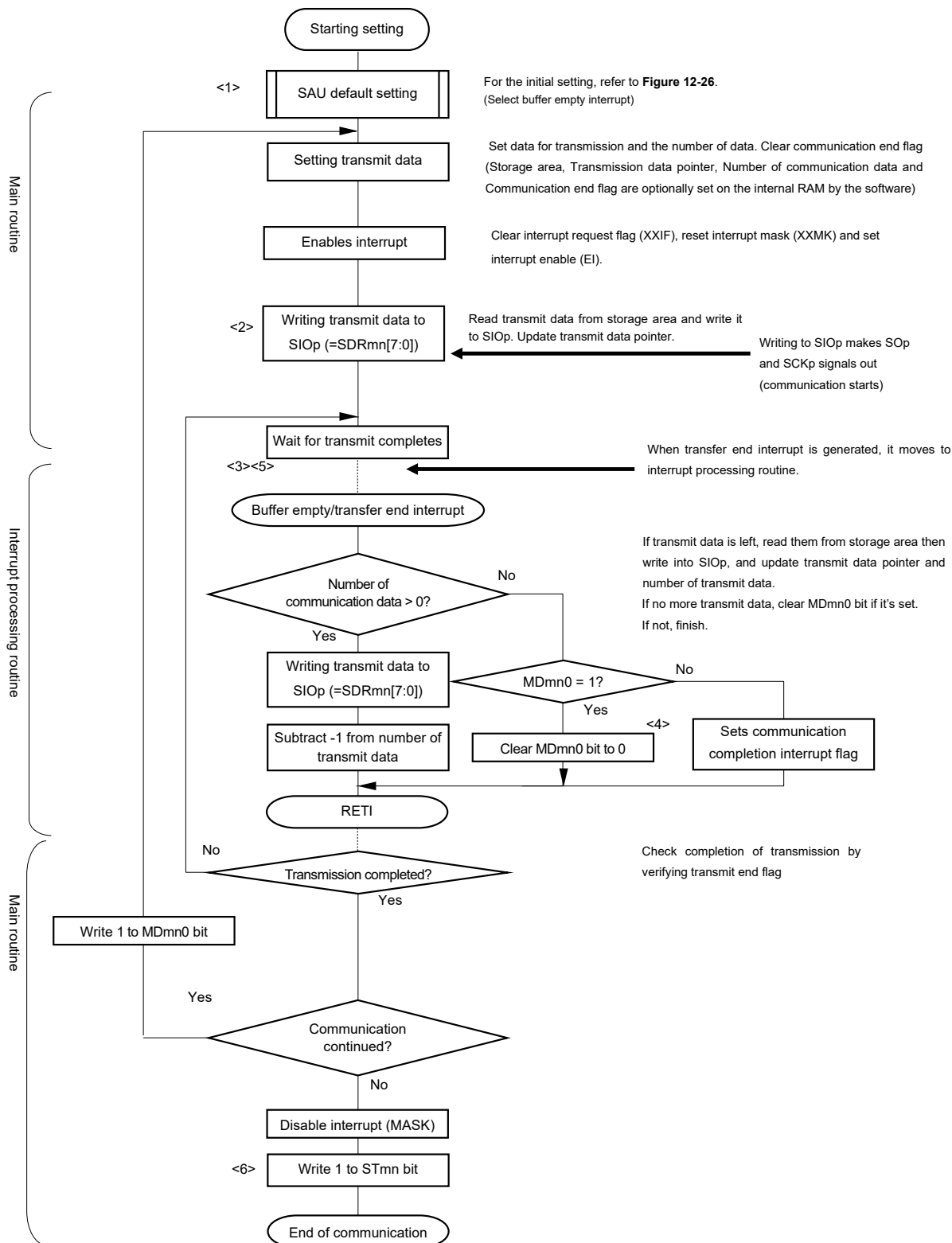

Remark <1> to <6> in the figure correspond to <1> to <6> in Figure 12-31 Timing Chart of Master Transmission (in Continuous Transmission Mode).

12.5.2 Master reception

Master reception is that the RL78 microcontroller outputs a transfer clock and receives data from other device.

Simplified SPI	CSI00	CSI01	CSI10	CSI11	CSI20	CSI21	CSI30	CSI31
Target channel	Channel 0 of SAU0	Channel 1 of SAU0	Channel 2 of SAU0	Channel 3 of SAU0	Channel 0 of SAU1	Channel 1 of SAU1	Channel 2 of SAU1	Channel 3 of SAU1
Pins used	SCK00, SI00	SCK01, SI01	SCK10, SI10	SCK11, SI11	SCK20, SI20	SCK21, SI21	SCK30, SI30	SCK31, SI31
Interrupt	INTCSI00	INTCSI01	INTCSI10	INTCSI11	INTCSI20	INTCSI21	INTCSI30	INTCSI31
	Transfer end interrupt (in single-transfer mode) or buffer empty interrupt (in continuous transfer mode) can be selected.							
Error detection flag	Overrun error detection flag (OVFmn) only							
Transfer data length	7 or 8 bits							
Transfer rate ^{Note}	Max. $f_{CLK}/2$ [Hz] (CSI00 only), $f_{CLK}/4$ [Hz] Min. $f_{CLK}/(2 \times 2^{15} \times 128)$ [Hz] f_{CLK} : System clock frequency							
Data phase	Selectable by the DAPmn bit of the SCRmn register <ul style="list-style-type: none"> • DAPmn = 0: Data input starts from the start of the operation of the serial clock. • DAPmn = 1: Data input starts half a clock before the start of the serial clock operation. 							
Clock phase	Selectable by the CKPmn bit of the SCRmn register <ul style="list-style-type: none"> • CKPmn = 0: Non-reverse • CKPmn = 1: Reverse 							
Data direction	MSB or LSB first							

Note Use this operation within a range that satisfies the conditions above and the peripheral functions characteristics in the electrical specifications (see **CHAPTER 29 ELECTRICAL SPECIFICATIONS (T_A = -40 to +85°C)** and **CHAPTER 30 ELECTRICAL SPECIFICATIONS (G: INDUSTRIAL APPLICATIONS T_A = -40 to +105°C)**).

Remark m: Unit number (m = 0, 1), n: Channel number (n = 0 to 3), mn = 00 to 03, 10 to 13

(1) Register setting

Figure 12-33. Example of Contents of Registers for Master Reception of simplified SPI (CSI00, CSI01, CSI10, CSI11, CSI20, CSI21, CSI30, CSI31) (1/2)

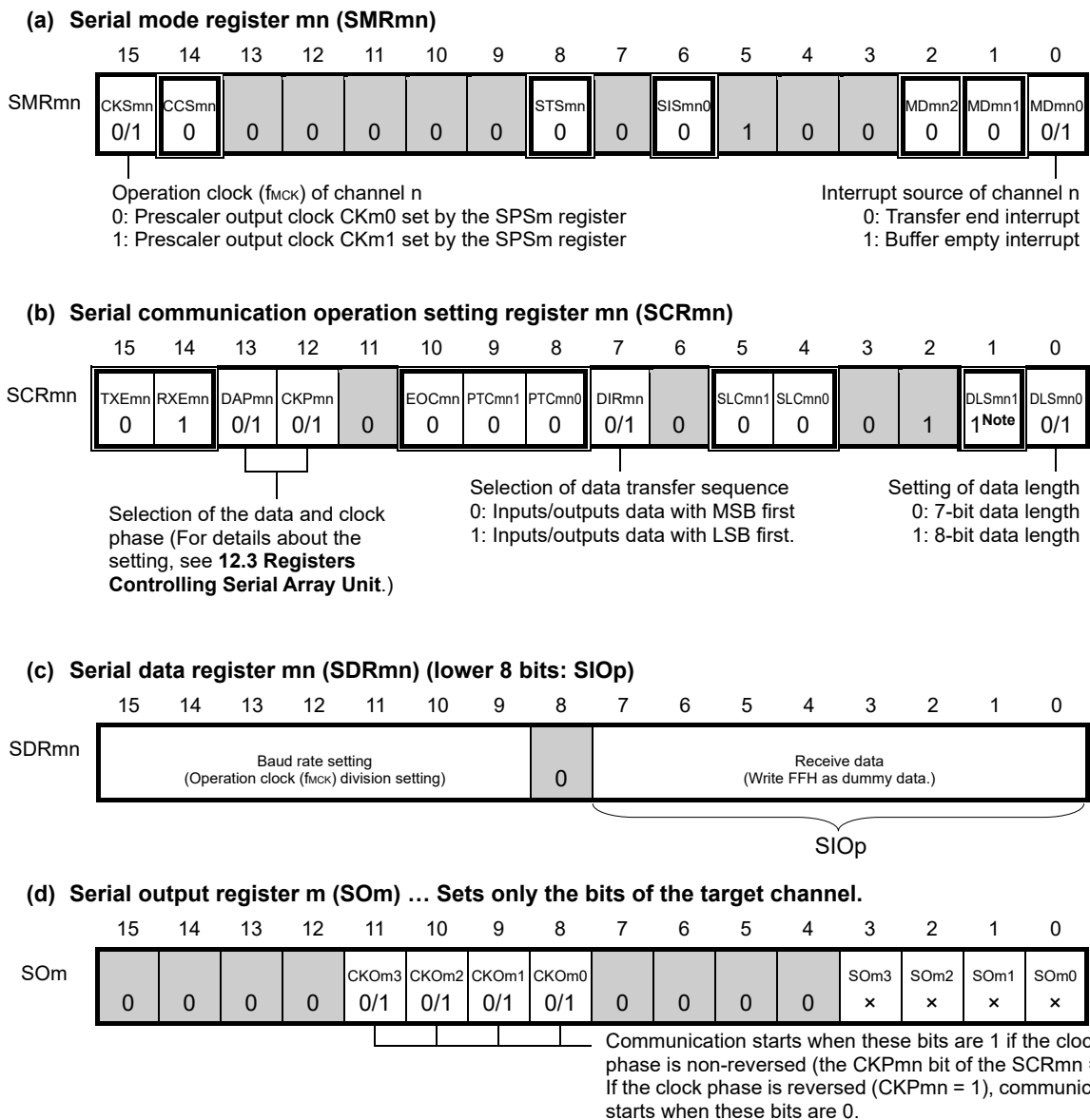

Note Only provided for the SCR00 and SCR01 registers and the SCR10 and SCR11 registers of an 80- to 128-pin product. This bit is fixed to 1 for the other registers.

- Remarks 1.** m: Unit number (m = 0, 1), n: Channel number (n = 0 to 3), p: CSI number (p = 00, 01, 10, 11, 20, 21, 30, 31), mn = 00 to 03, 10 to 13
- 2.** □: Setting is fixed in the simplified SPI (CSI) master reception mode, ■: Setting disabled (set to the initial value)
 ×: Bit that cannot be used in this mode (set to the initial value when not used in any mode)
 0/1: Set to 0 or 1 depending on the usage of the user

Figure 12-33. Example of Contents of Registers for Master Reception of simplified SPI (CSI00, CSI01, CSI10, CSI11, CSI20, CSI21, CSI30, CSI31) (2/2)

(e) Serial output enable register m (SOEm) ...The register that not used in this mode.

	15	14	13	12	11	10	9	8	7	6	5	4	3	2	1	0
SOEm	0	0	0	0	0	0	0	0	0	0	0	0	SOEm3	SOEm2	SOEm1	SOEm0
													x	x	x	x

(f) Serial channel start register m (SSm) ... Sets only the bits of the target channel to 1.

	15	14	13	12	11	10	9	8	7	6	5	4	3	2	1	0
SSm	0	0	0	0	0	0	0	0	0	0	0	0	SSm3	SSm2	SSm1	SSm0
													0/1	0/1	0/1	0/1

- Remarks**
- m: Unit number (m = 0, 1)
 - : Setting disabled (set to the initial value)
 - x: Bit that cannot be used in this mode (set to the initial value when not used in any mode)
 - 0/1: Set to 0 or 1 depending on the usage of the user

(2) Operation procedure

Figure 12-34. Initial Setting Procedure for Master Reception

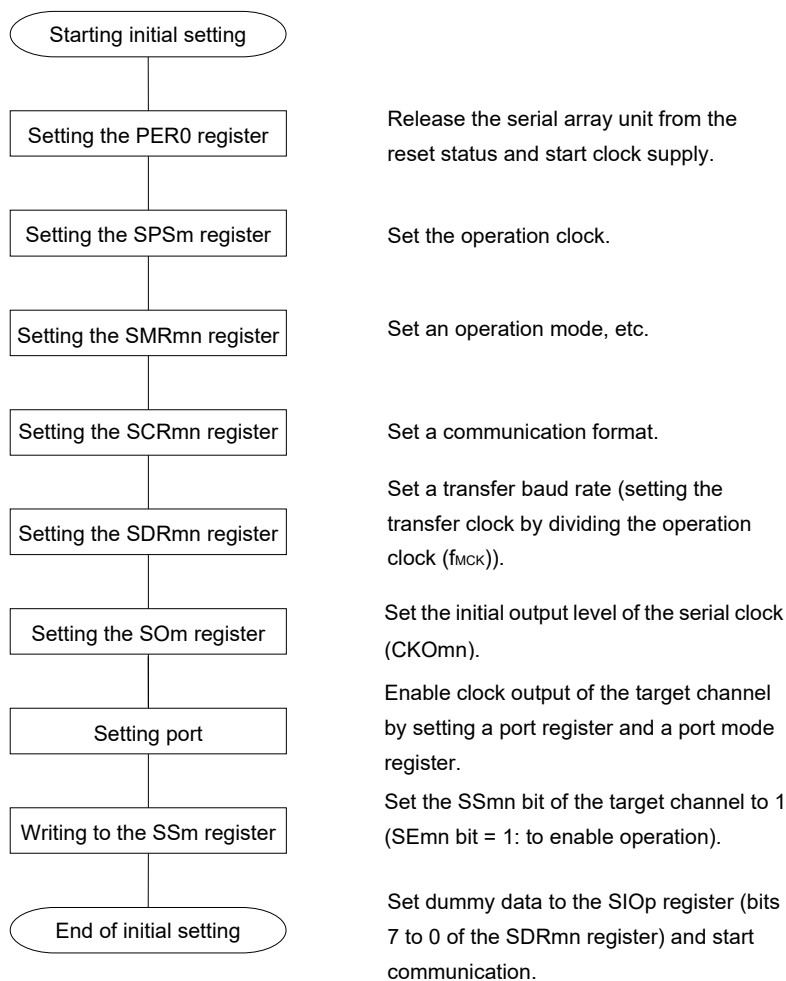

Figure 12-35. Procedure for Stopping Master Reception

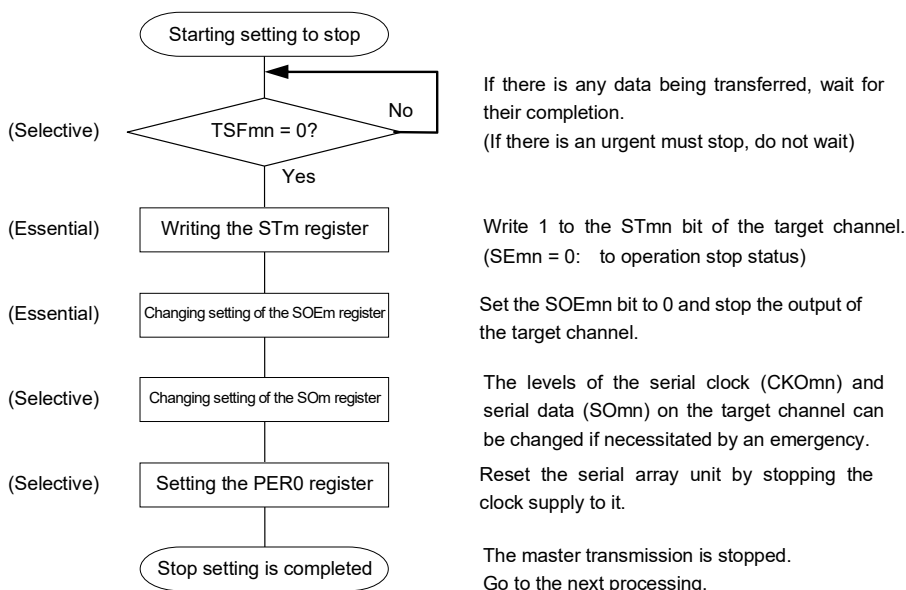
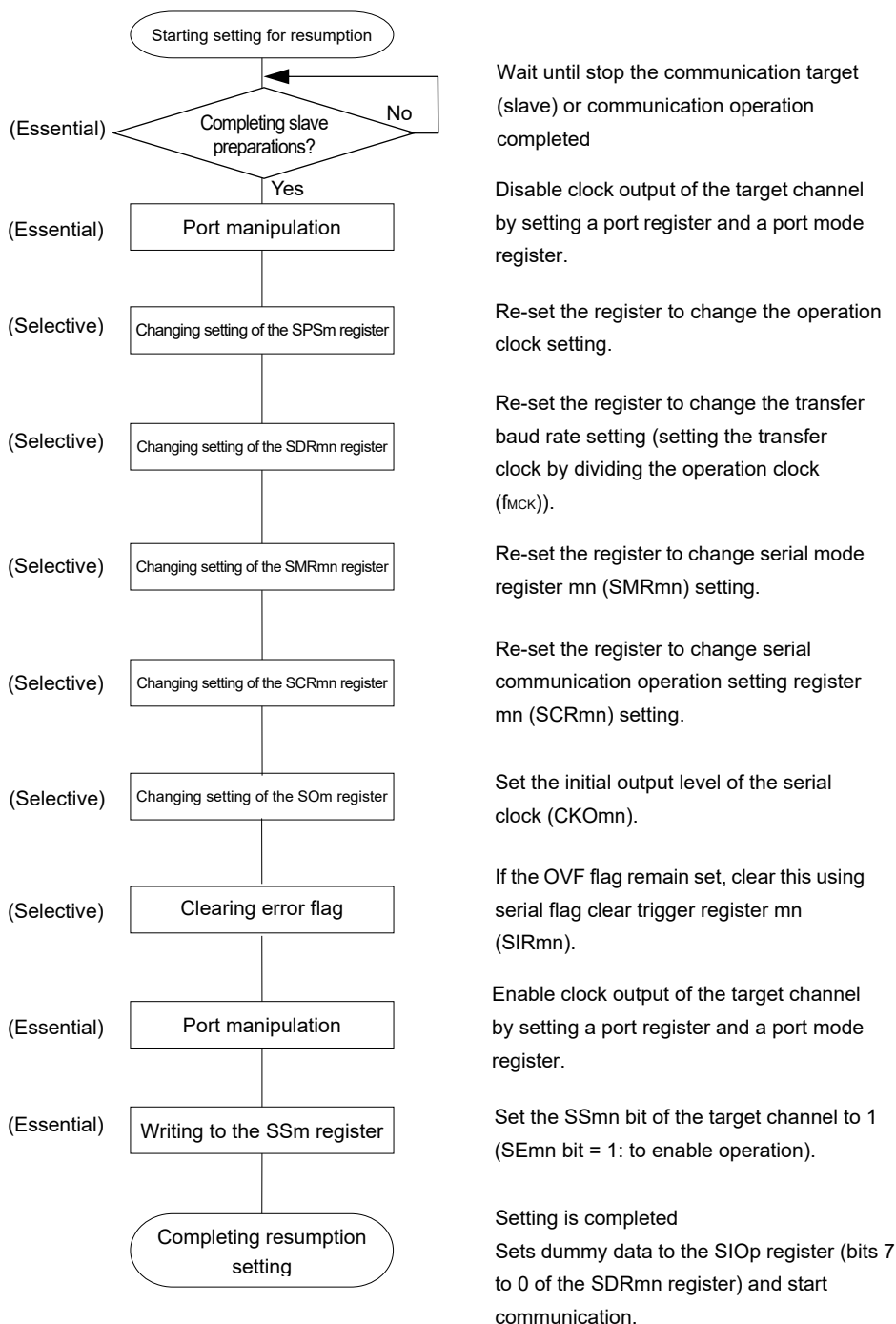

Figure 12-36. Procedure for Resuming Master Reception



Remark If PER0 is rewritten while stopping the master transmission and the clock supply is stopped, wait until the transmission target (slave) stops or transmission finishes, and then perform initialization instead of restarting the transmission.

(3) Processing flow (in single-reception mode)

Figure 12-37. Timing Chart of Master Reception (in Single-Reception Mode)
 (Type 1: DAPmn = 0, CKPmn = 0)

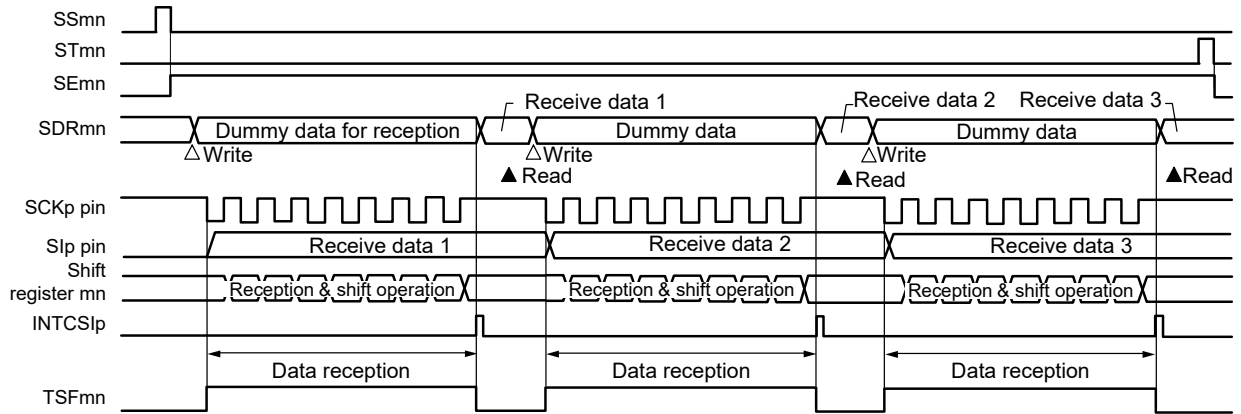

Remark m: Unit number (m = 0, 1), n: Channel number (n = 0 to 3), p: CSI number (p = 00, 01, 10, 11, 20, 21, 30, 31), mn = 00 to 03, 10 to 13

Figure 12-38. Flowchart of Master Reception (in Single-Reception Mode)

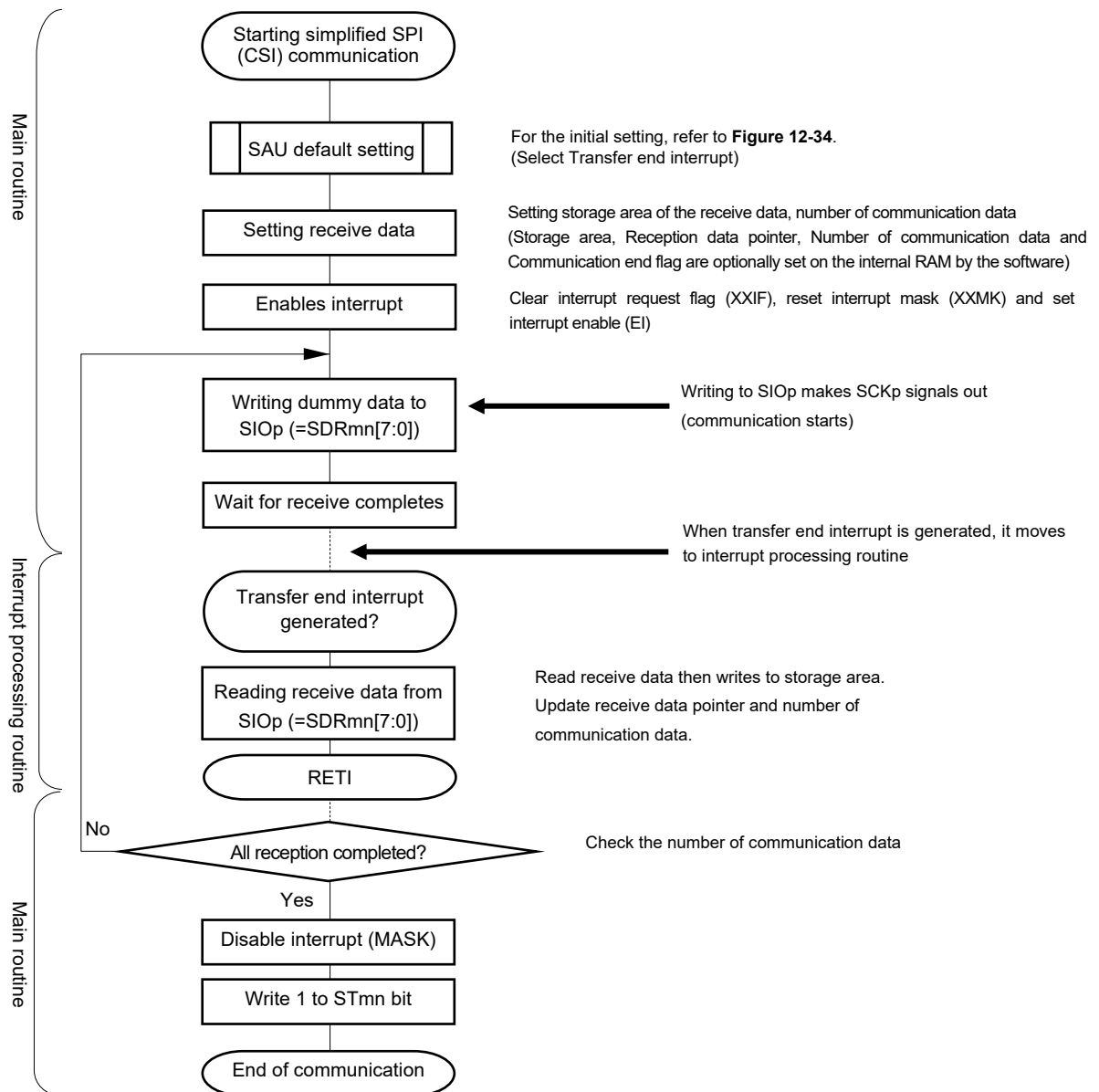

(4) Processing flow (in continuous reception mode)

Figure 12-39. Timing Chart of Master Reception (in Continuous Reception Mode) (Type 1: DAPmn = 0, CKPmn = 0)

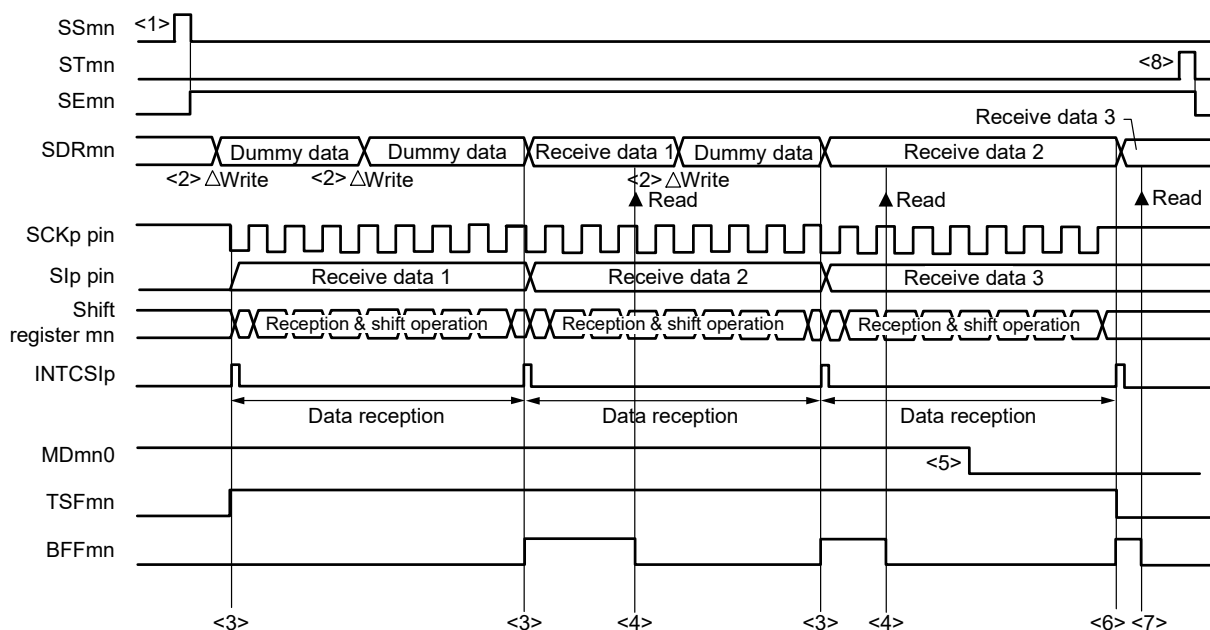

Caution The MDmn0 bit can be rewritten even during operation. However, rewrite it before receive of the last bit is started, so that it has been rewritten before the transfer end interrupt of the last receive data.

- Remarks**
1. $\langle 1 \rangle$ to $\langle 8 \rangle$ in the figure correspond to $\langle 1 \rangle$ to $\langle 8 \rangle$ in **Figure 12-40 Flowchart of Master Reception (in Continuous Reception Mode)**.
 2. m: Unit number (m = 0, 1), n: Channel number (n = 0 to 3), p: CSI number (p = 00, 01, 10, 11, 20, 21, 30, 31), mn = 00 to 03, 10 to 13

Figure 12-40. Flowchart of Master Reception (in Continuous Reception Mode)

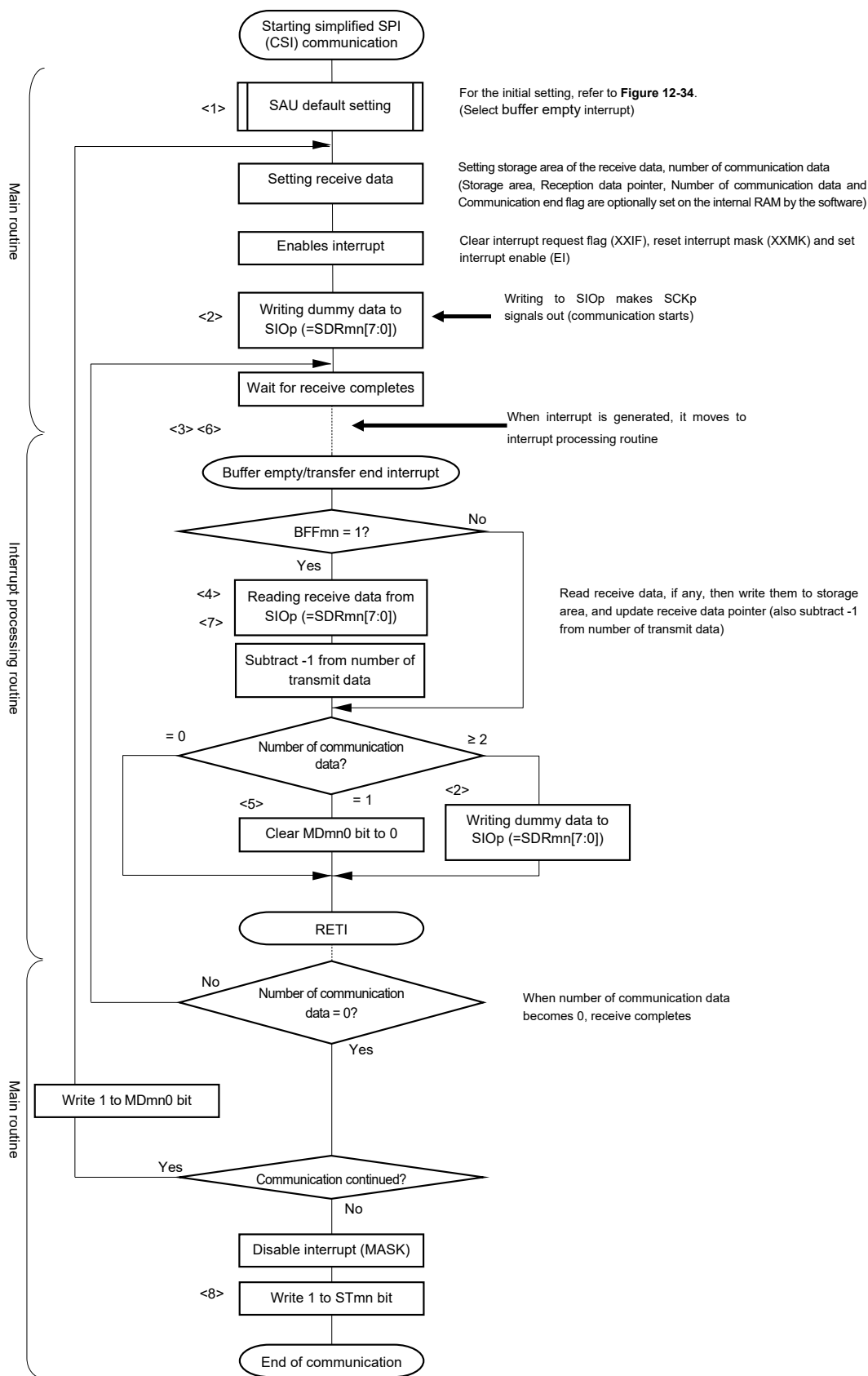

Remark <1> to <8> in the figure correspond to <1> to <8> in Figure 12-39 Timing Chart of Master Reception (in Continuous Reception Mode).

12.5.3 Master transmission/reception

Master transmission/reception is that the RL78 microcontroller outputs a transfer clock and transmits/receives data to/from other device.

Simplified SPI	CSI00	CSI01	CSI10	CSI11	CSI20	CSI21	CSI30	CSI31
Target channel	Channel 0 of SAU0	Channel 1 of SAU0	Channel 2 of SAU0	Channel 3 of SAU0	Channel 0 of SAU1	Channel 1 of SAU1	Channel 2 of SAU1	Channel 3 of SAU1
Pins used	SCK00, SI00, SO00	SCK01, SI01, SO01	SCK10, SI10, SO10	SCK11, SI11, SO11	SCK20, SI20, SO20	SCK21, SI21, SO21	SCK30, SI30, SO30	SCK31, SI31, SO31
Interrupt	INTCSI00	INTCSI01	INTCSI10	INTCSI11	INTCSI20	INTCSI21	INTCSI30	INTCSI31
	Transfer end interrupt (in single-transfer mode) or buffer empty interrupt (in continuous transfer mode) can be selected.							
Error detection flag	Overrun error detection flag (OVFmn) only							
Transfer data length	7 or 8 bits							
Transfer rate ^{Note}	Max. $f_{CLK}/2$ [Hz] (CSI00 only), $f_{CLK}/4$ [Hz] Min. $f_{CLK}/(2 \times 2^{15} \times 128)$ [Hz] f_{CLK} : System clock frequency							
Data phase	Selectable by the DAPmn bit of the SCRmn register <ul style="list-style-type: none"> • DAPmn = 0: Data I/O starts at the start of the operation of the serial clock. • DAPmn = 1: Data I/O starts half a clock before the start of the serial clock operation. 							
Clock phase	Selectable by the CKPmn bit of the SCRmn register <ul style="list-style-type: none"> • CKPmn = 0: Non-reverse • CKPmn = 1: Reverse 							
Data direction	MSB or LSB first							

Note Use this operation within a range that satisfies the conditions above and the peripheral functions characteristics in the electrical specifications (see **CHAPTER 29 ELECTRICAL SPECIFICATIONS (T_A = -40 to +85°C)** and **CHAPTER 30 ELECTRICAL SPECIFICATIONS (G: INDUSTRIAL APPLICATIONS T_A = -40 to +105°C)**).

Remark m: Unit number (m = 0, 1), n: Channel number (n = 0 to 3), mn = 00 to 03, 10 to 13

(1) Register setting

Figure 12-41. Example of Contents of Registers for Master Transmission/Reception of simplified SPI (CSI00, CSI01, CSI10, CSI11, CSI20, CSI21, CSI30, CSI31) (1/2)

(a) Serial mode register mn (SMRmn)

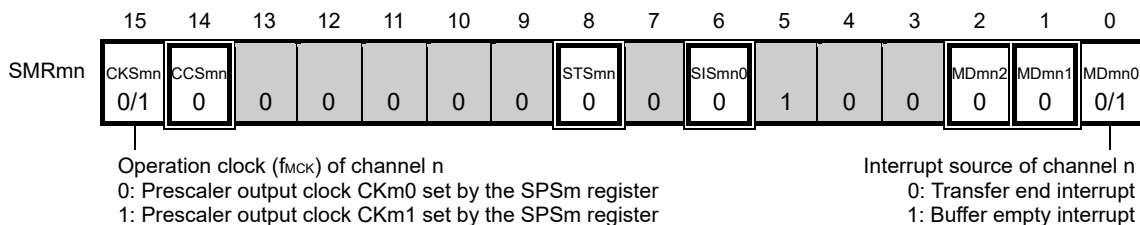

(b) Serial communication operation setting register mn (SCRmn)

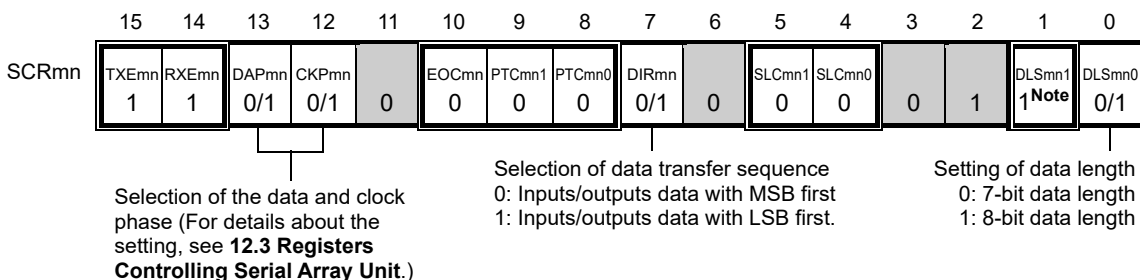

(c) Serial data register mn (SDRmn) (lower 8 bits: SIOp)

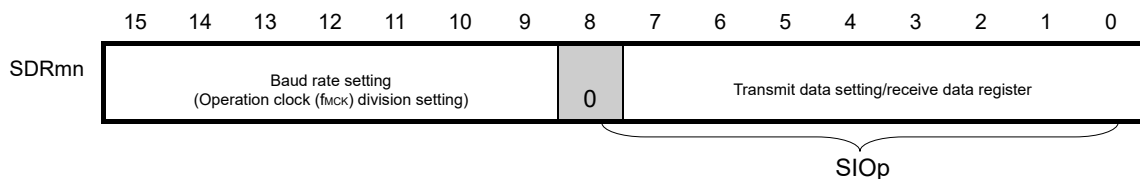

(d) Serial output register m (SOM) ... Sets only the bits of the target channel.

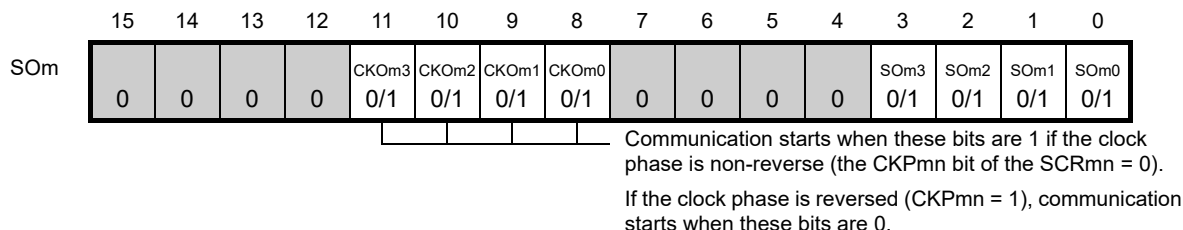

Note Only provided for the SCR00 and SCR01 registers and the SCR10 and SCR11 registers of an 80- to 128-pin product. This bit is fixed to 1 for the other registers.

- Remarks**
- m: Unit number (m = 0, 1), n: Channel number (n = 0 to 3), p: CSI number (p = 00, 01, 10, 11, 20, 21, 30, 31), mn = 00 to 03, 10 to 13
 - : Setting is fixed in the simplified SPI (CSI) master transmission/reception mode
 ■: Setting disabled (set to the initial value)
 0/1: Set to 0 or 1 depending on the usage of the user

Figure 12-41. Example of Contents of Registers for Master Transmission/Reception of simplified SPI (CSI00, CSI01, CSI10, CSI11, CSI20, CSI21, CSI30, CSI31) (2/2)

(e) Serial output enable register m (SOEm) ... Sets only the bits of the target channel to 1.

	15	14	13	12	11	10	9	8	7	6	5	4	3	2	1	0
SOEm	0	0	0	0	0	0	0	0	0	0	0	0	SOEm3	SOEm2	SOEm1	SOEm0
	0	0	0	0	0	0	0	0	0	0	0	0	0/1	0/1	0/1	0/1

(f) Serial channel start register m (SSm) ... Sets only the bits of the target channel to 1.

	15	14	13	12	11	10	9	8	7	6	5	4	3	2	1	0
SSm	0	0	0	0	0	0	0	0	0	0	0	0	SSm3	SSm2	SSm1	SSm0
	0	0	0	0	0	0	0	0	0	0	0	0	0/1	0/1	0/1	0/1

- Remarks**
1. m: Unit number (m = 0, 1)
 2. : Setting disabled (set to the initial value)
 0/1: Set to 0 or 1 depending on the usage of the user

(2) Operation procedure

Figure 12-42. Initial Setting Procedure for Master Transmission/Reception

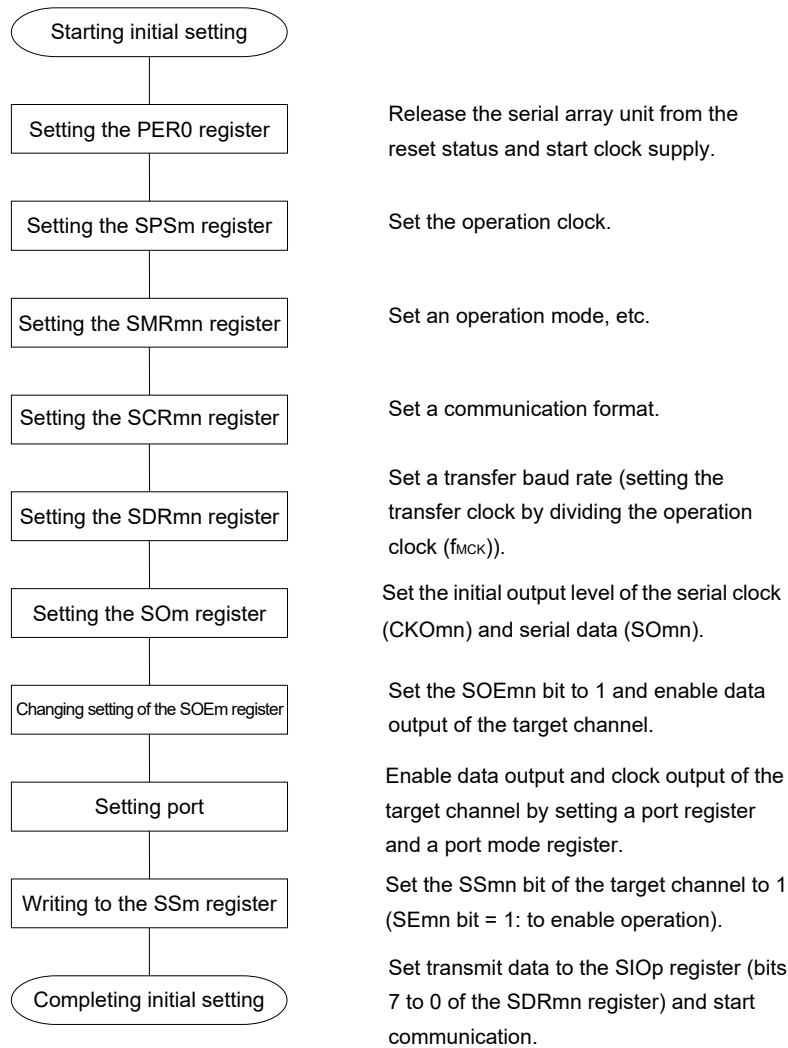

Figure 12-43. Procedure for Stopping Master Transmission/Reception

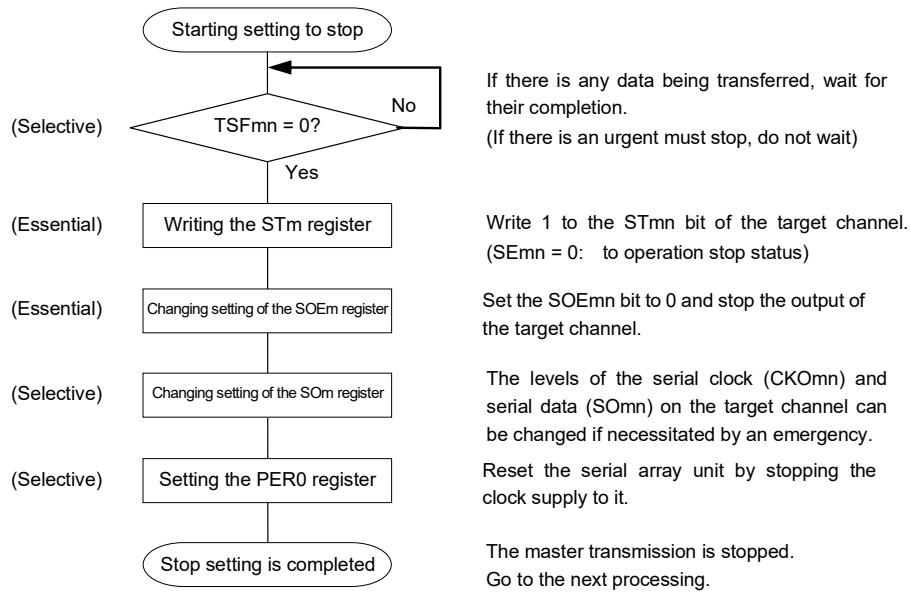
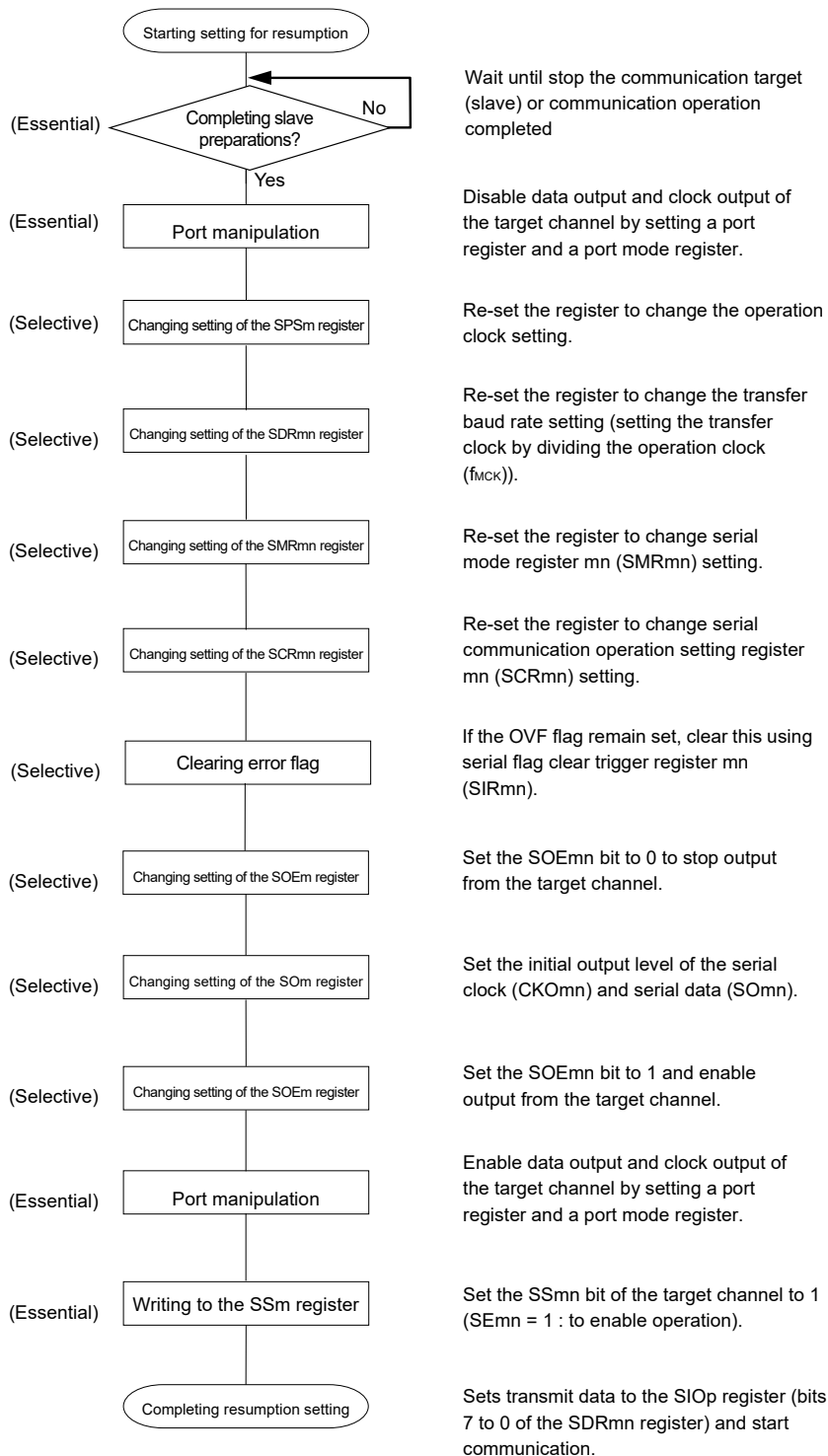
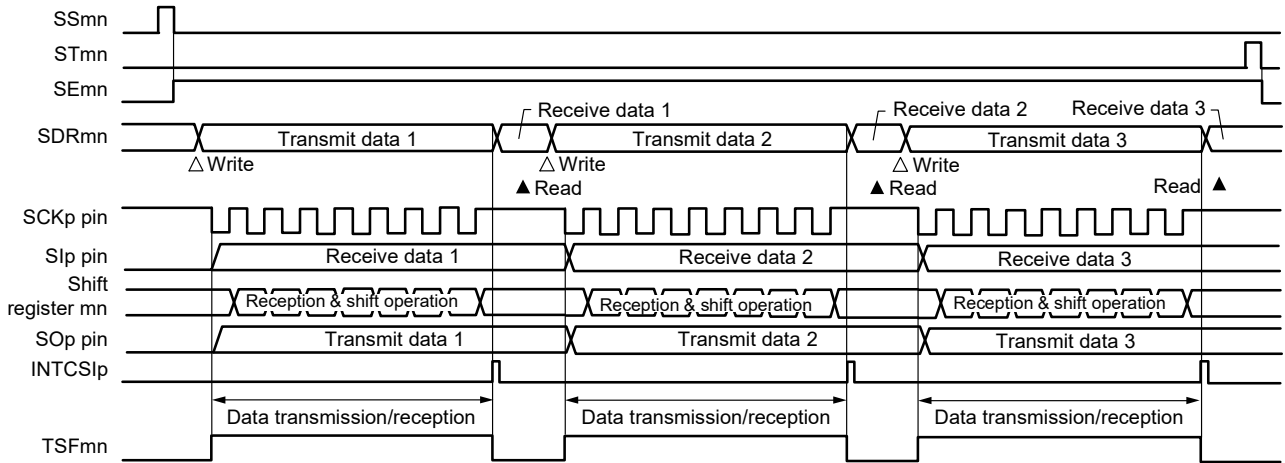

Figure 12-44. Procedure for Resuming Master Transmission/Reception



(3) Processing flow (in single-transmission/reception mode)

Figure 12-45. Timing Chart of Master Transmission/Reception (in Single-Transmission/Reception Mode)
(Type 1: DAPmn = 0, CKPmn = 0)



Remark m: Unit number (m = 0, 1), n: Channel number (n = 0 to 3), p: CSI number (p = 00, 01, 10, 11, 20, 21, 30, 31), mn = 00 to 03, 10 to 13

Figure 12-46. Flowchart of Master Transmission/Reception (in Single-Transmission/Reception Mode)

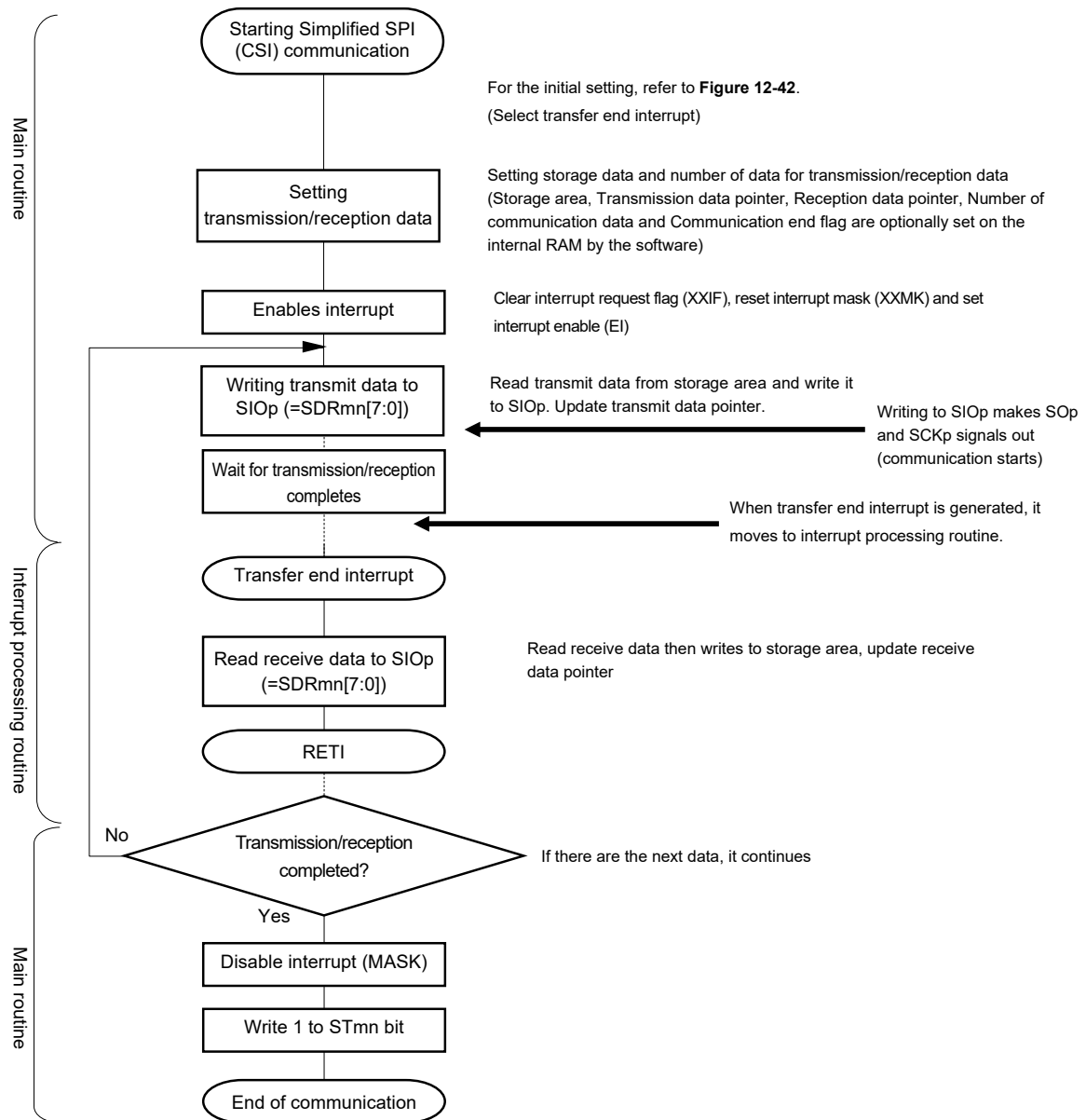

(4) Processing flow (in continuous transmission/reception mode)

Figure 12-47. Timing Chart of Master Transmission/Reception (in Continuous Transmission/Reception Mode)
(Type 1: DAPmn = 0, CKPmn = 0)

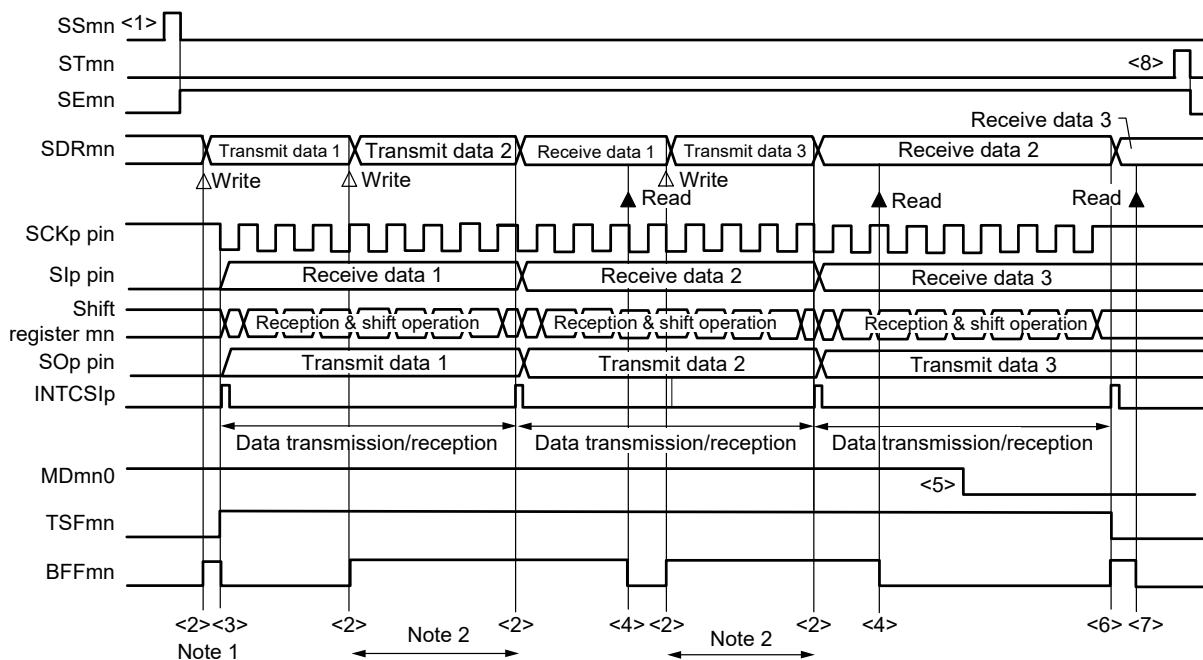

- Notes**
1. If transmit data is written to the SDRmn register while the BFFmn bit of serial status register mn (SSRmn) is 1 (valid data is stored in serial data register mn (SDRmn)), the transmit data is overwritten.
 2. The transmit data can be read by reading the SDRmn register during this period. At this time, the transfer operation is not affected.

Caution The MDmn0 bit of serial mode register mn (SMRmn) can be rewritten even during operation. However, rewrite it before transfer of the last bit is started, so that it has been rewritten before the transfer end interrupt of the last transmit data.

- Remarks**
1. <1> to <8> in the figure correspond to <1> to <8> in Figure 12-48 Flowchart of Master Transmission/Reception (in Continuous Transmission/Reception Mode).
 2. m: Unit number (m = 0, 1), n: Channel number (n = 0 to 3), p: CSI number (p = 00, 01, 10, 11, 20, 21, 30, 31), mn = 00 to 03, 10 to 13

Figure 12-48. Flowchart of Master Transmission/Reception (in Continuous Transmission/Reception Mode)

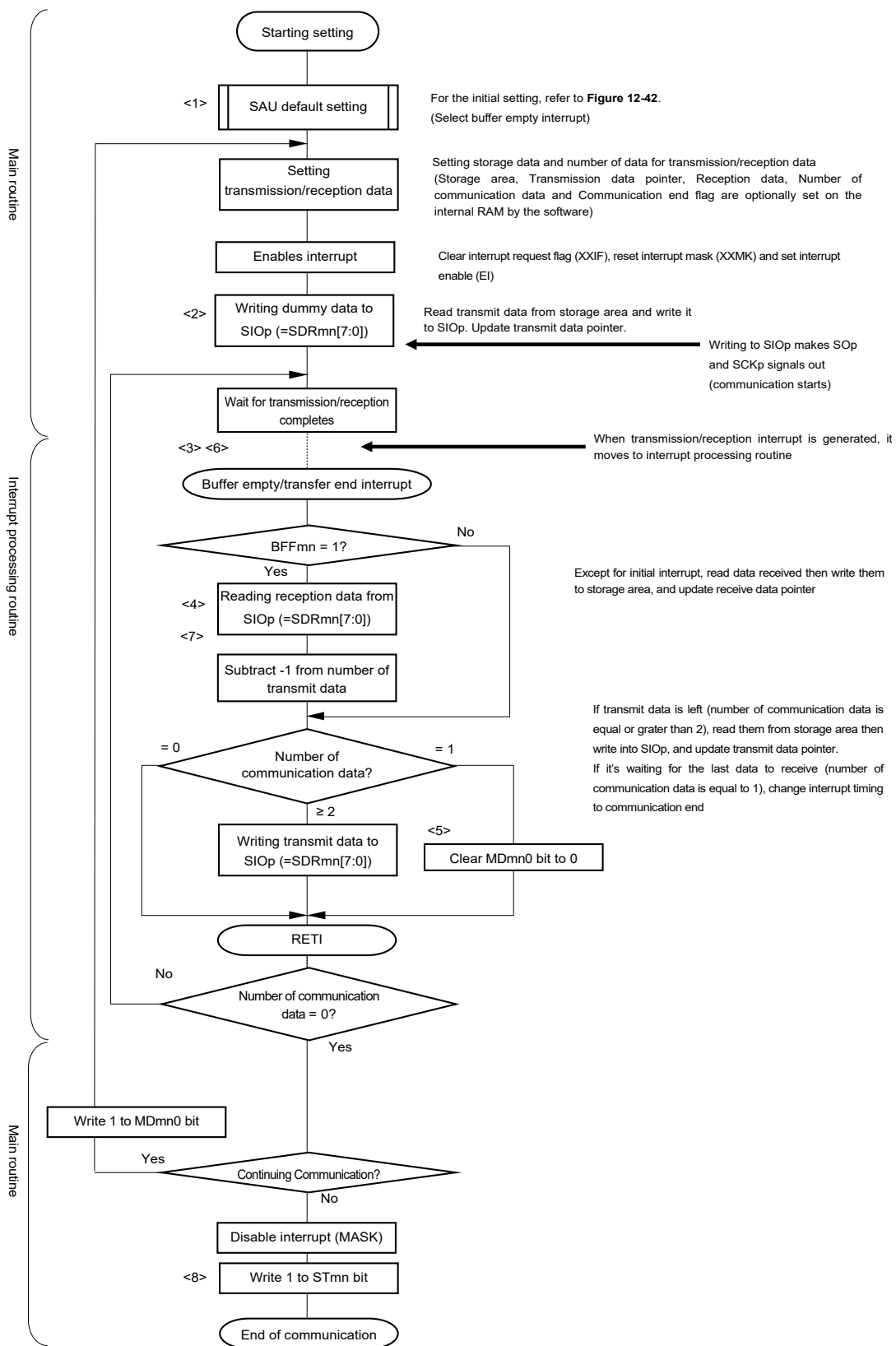

Remark <1> to <8> in the figure correspond to <1> to <8> in **Figure 12-47 Timing Chart of Master Transmission/Reception (in Continuous Transmission/Reception Mode)**.

12.5.4 Slave transmission

Slave transmission is that the RL78 microcontroller transmits data to another device in the state of a transfer clock being input from another device.

Simplified SPI	CSI00	CSI01	CSI10	CSI11	CSI20	CSI21	CSI30	CSI31
Target channel	Channel 0 of SAU0	Channel 1 of SAU0	Channel 2 of SAU0	Channel 3 of SAU0	Channel 0 of SAU1	Channel 1 of SAU1	Channel 2 of SAU1	Channel 3 of SAU1
Pins used	SCK00, SO00	SCK01, SO01	SCK10, SO10	SCK11, SO11	SCK20, SO20	SCK21, SO21	SCK30, SO30	SCK31, SO31
Interrupt	INTCSI00	INTCSI01	INTCSI10	INTCSI11	INTCSI20	INTCSI21	INTCSI30	INTCSI31
	Transfer end interrupt (in single-transfer mode) or buffer empty interrupt (in continuous transfer mode) can be selected.							
Error detection flag	Overrun error detection flag (OVFmn) only							
Transfer data length	7 or 8 bits							
Transfer rate	Max. $f_{MCK}/6$ [Hz] ^{Notes 1, 2} .							
Data phase	Selectable by the DAPmn bit of the SCRmn register <ul style="list-style-type: none"> • DAPmn = 0: Data output starts from the start of the operation of the serial clock. • DAPmn = 1: Data output starts half a clock before the start of the serial clock operation. 							
Clock phase	Selectable by the CKPmn bit of the SCRmn register <ul style="list-style-type: none"> • CKPmn = 0: Non-reverse • CKPmn = 1: Reverse 							
Data direction	MSB or LSB first							

Notes 1. Because the external serial clock input to the SCK00, SCK01, SCK10, SCK11, SCK20, SCK21, SCK30, and SCK31 pins is sampled internally and used, the fastest transfer rate is $f_{MCK}/6$ [Hz].

2. Use this operation within a range that satisfies the conditions above and the peripheral functions characteristics in the electrical specifications (see **CHAPTER 29 ELECTRICAL SPECIFICATIONS (T_A = -40 to +85°C)** and **CHAPTER 30 ELECTRICAL SPECIFICATIONS (G: INDUSTRIAL APPLICATIONS T_A = -40 to +105°C)**).

Remarks 1. f_{MCK} : Operation clock frequency of target channel

f_{SCK} : Serial clock frequency

2. m: Unit number (m = 0, 1), n: Channel number (n = 0 to 3), mn = 00 to 03, 10 to 13

(1) Register setting

Figure 12-49. Example of Contents of Registers for Slave Transmission of simplified SPI (CSI00, CSI01, CSI10, CSI11, CSI20, CSI21, CSI30, CSI31) (1/2)

(a) Serial mode register mn (SMRmn)

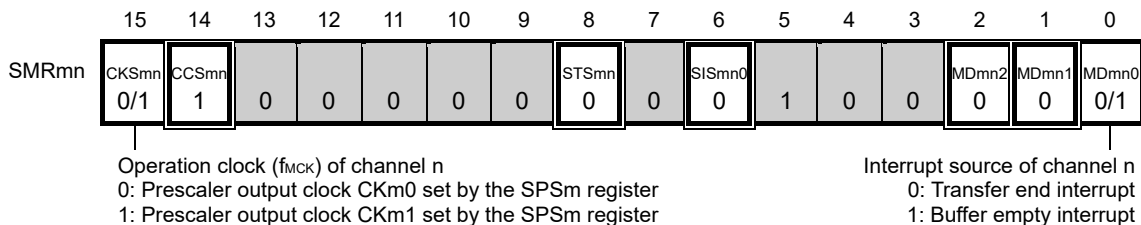

(b) Serial communication operation setting register mn (SCRmn)

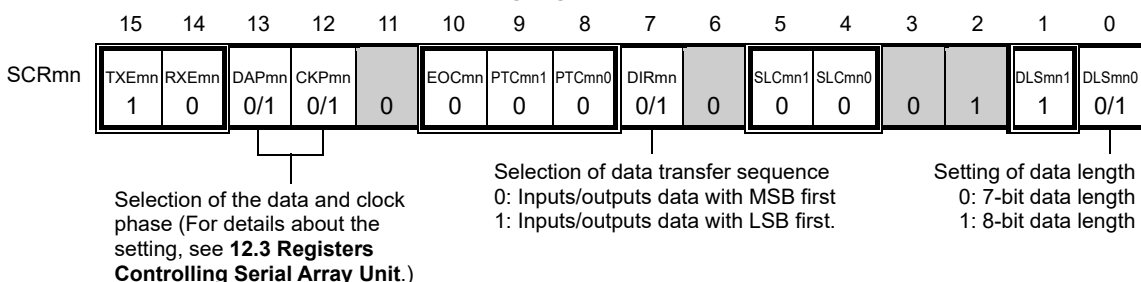

(c) Serial data register mn (SDRmn) (lower 8 bits: SIOp)

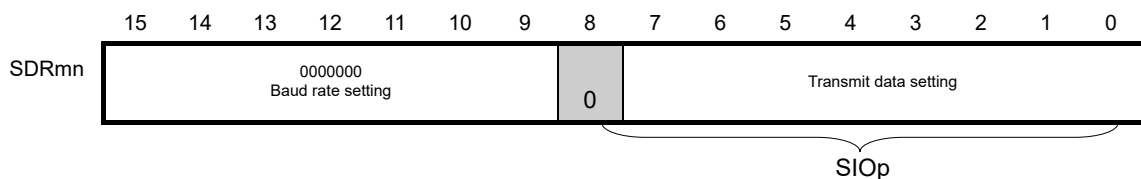

(d) Serial output register m (SOM) ... Sets only the bits of the target channel.

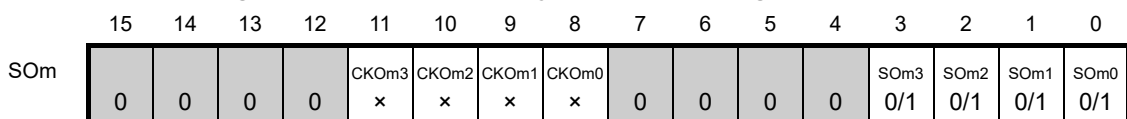

- Remarks 1.** m: Unit number (m = 0, 1), n: Channel number (n = 0 to 3), p: CSI number (p = 00, 01, 10, 11, 20, 21, 30, 31), mn = 00 to 03, 10 to 13
- 2.** □: Setting is fixed in the simplified SPI (CSI) slave transmission mode, ■: Setting disabled (set to the initial value)
 x: Bit that cannot be used in this mode (set to the initial value when not used in any mode)
 0/1: Set to 0 or 1 depending on the usage of the user

Figure 12-49. Example of Contents of Registers for Slave Transmission of simplified SPI (CSI00, CSI01, CSI10, CSI11, CSI20, CSI21, CSI30, CSI31) (2/2)

(e) Serial output enable register m (SOEm) ... Sets only the bits of the target channel to 1.

	15	14	13	12	11	10	9	8	7	6	5	4	3	2	1	0
SOEm	0	0	0	0	0	0	0	0	0	0	0	0	SOEm3 0/1	SOEm2 0/1	SOEm1 0/1	SOEm0 0/1

(f) Serial channel start register m (SSm) ... Sets only the bits of the target channel to 1.

	15	14	13	12	11	10	9	8	7	6	5	4	3	2	1	0
SSm	0	0	0	0	0	0	0	0	0	0	0	0	SSm3 0/1	SSm2 0/1	SSm1 0/1	SSm0 0/1

- Remarks**
1. m: Unit number (m = 0, 1)
 2. : Setting disabled (set to the initial value)
0/1: Set to 0 or 1 depending on the usage of the user

(2) Operation procedure

Figure 12-50. Initial Setting Procedure for Slave Transmission

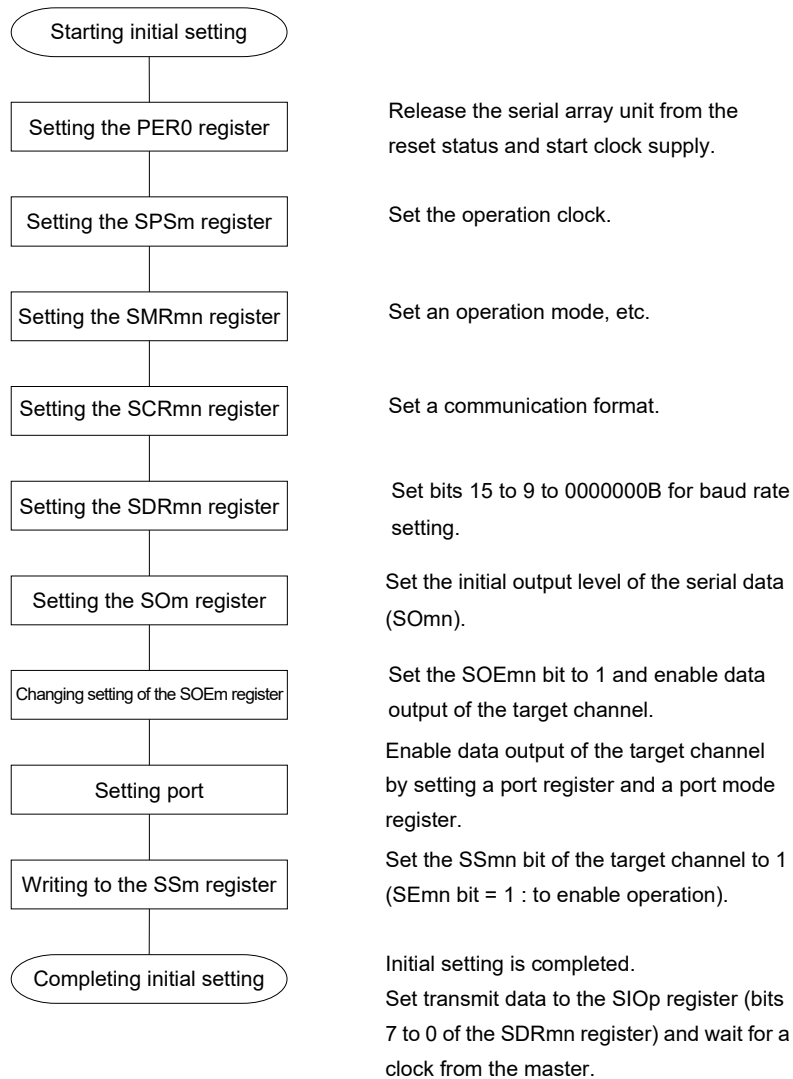

Figure 12-51. Procedure for Stopping Slave Transmission

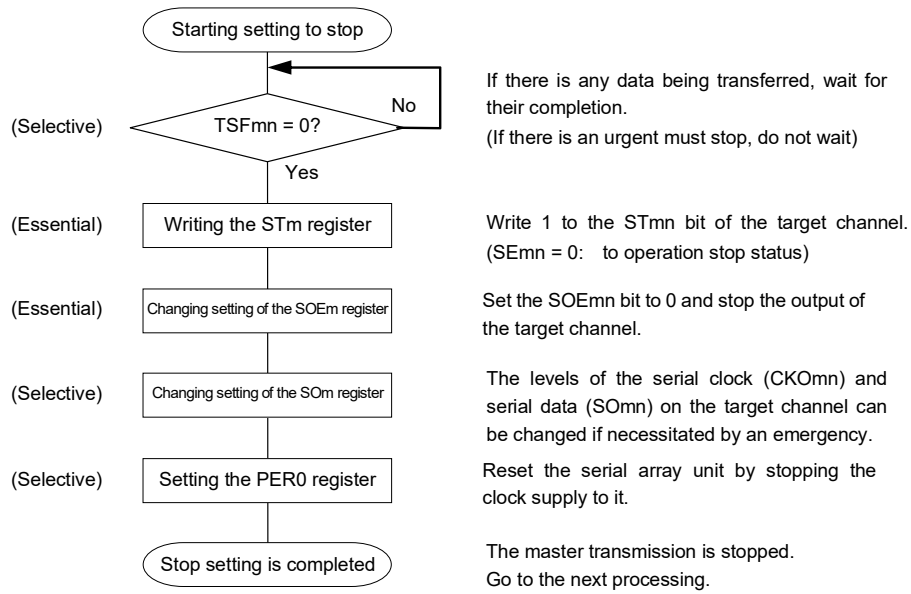
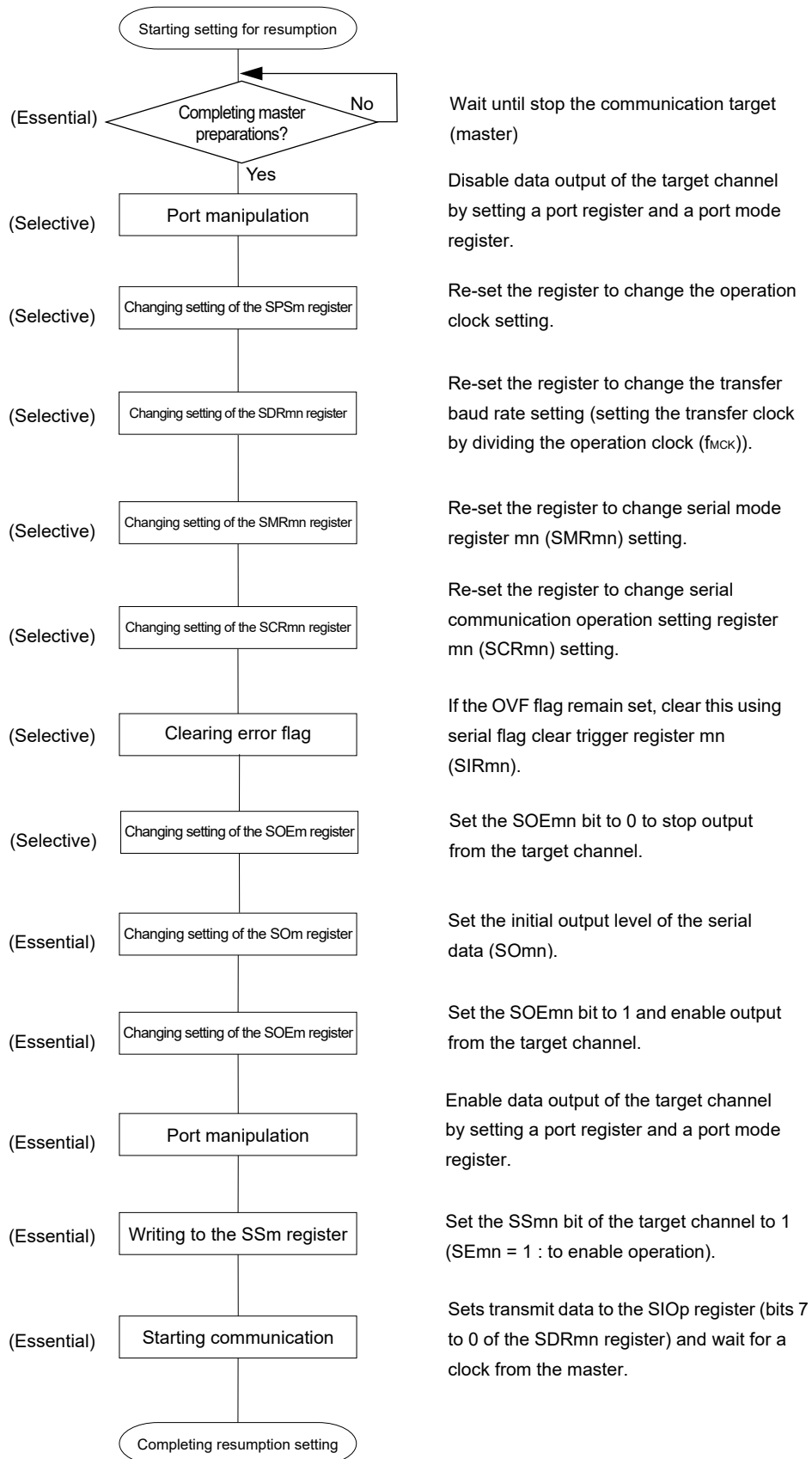

Figure 12-52. Procedure for Resuming Slave Transmission



(Remark is listed on the next page.)

Remark If PER0 is rewritten while stopping the master transmission and the clock supply is stopped, wait until the transmission target (master) stops or transmission finishes, and then perform initialization instead of restarting the transmission.

(3) Processing flow (in single-transmission mode)

Figure 12-53. Timing Chart of Slave Transmission (in Single-Transmission Mode)
(Type 1: DAPmn = 0, CKPmn = 0)

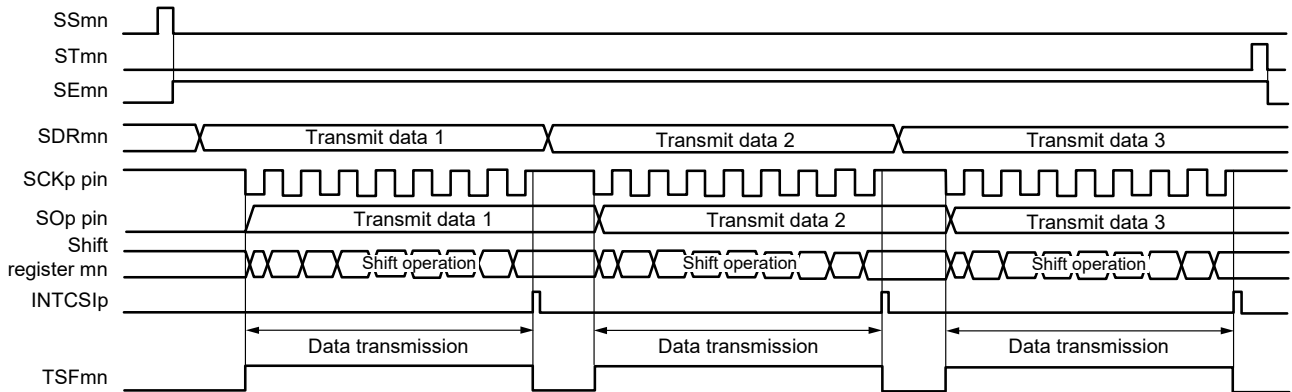

Remark m: Unit number (m = 0, 1), n: Channel number (n = 0 to 3), p: CSI number (p = 00, 01, 10, 11, 20, 21, 30, 31), mn = 00 to 03, 10 to 13

Figure 12-54. Flowchart of Slave Transmission (in Single-Transmission Mode)

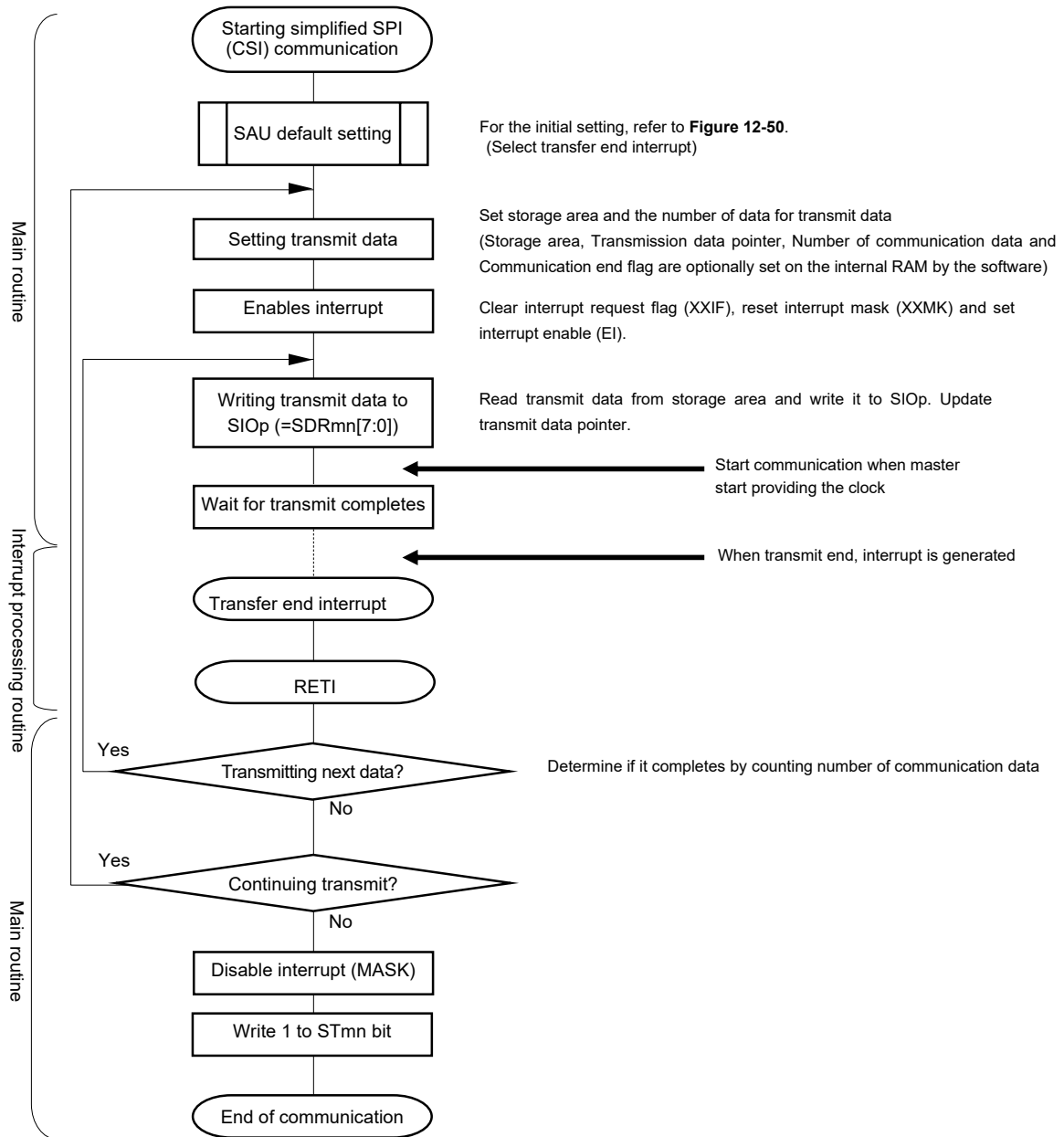

(4) Processing flow (in continuous transmission mode)

Figure 12-55. Timing Chart of Slave Transmission (in Continuous Transmission Mode)
 (Type 1: DAPmn = 0, CKPmn = 0)

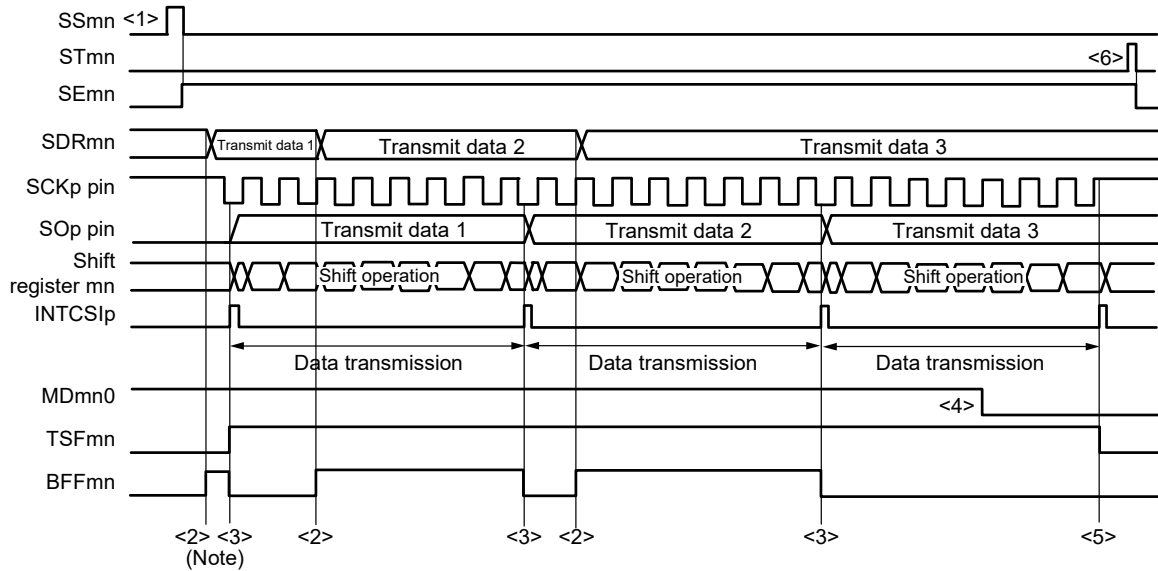

Note If transmit data is written to the SDRmn register while the BFFmn bit of serial status register mn (SSRmn) is 1 (valid data is stored in serial data register mn (SDRmn)), the transmit data is overwritten.

Caution The MDmn0 bit of serial mode register mn (SMRmn) can be rewritten even during operation. However, rewrite it before transfer of the last bit is started.

Remark m: Unit number (m = 0, 1), n: Channel number (n = 0 to 3), p: CSI number (p = 00, 01, 10, 11, 20, 21, 30, 31), mn = 00 to 03, 10 to 13

Figure 12-56. Flowchart of Slave Transmission (in Continuous Transmission Mode)

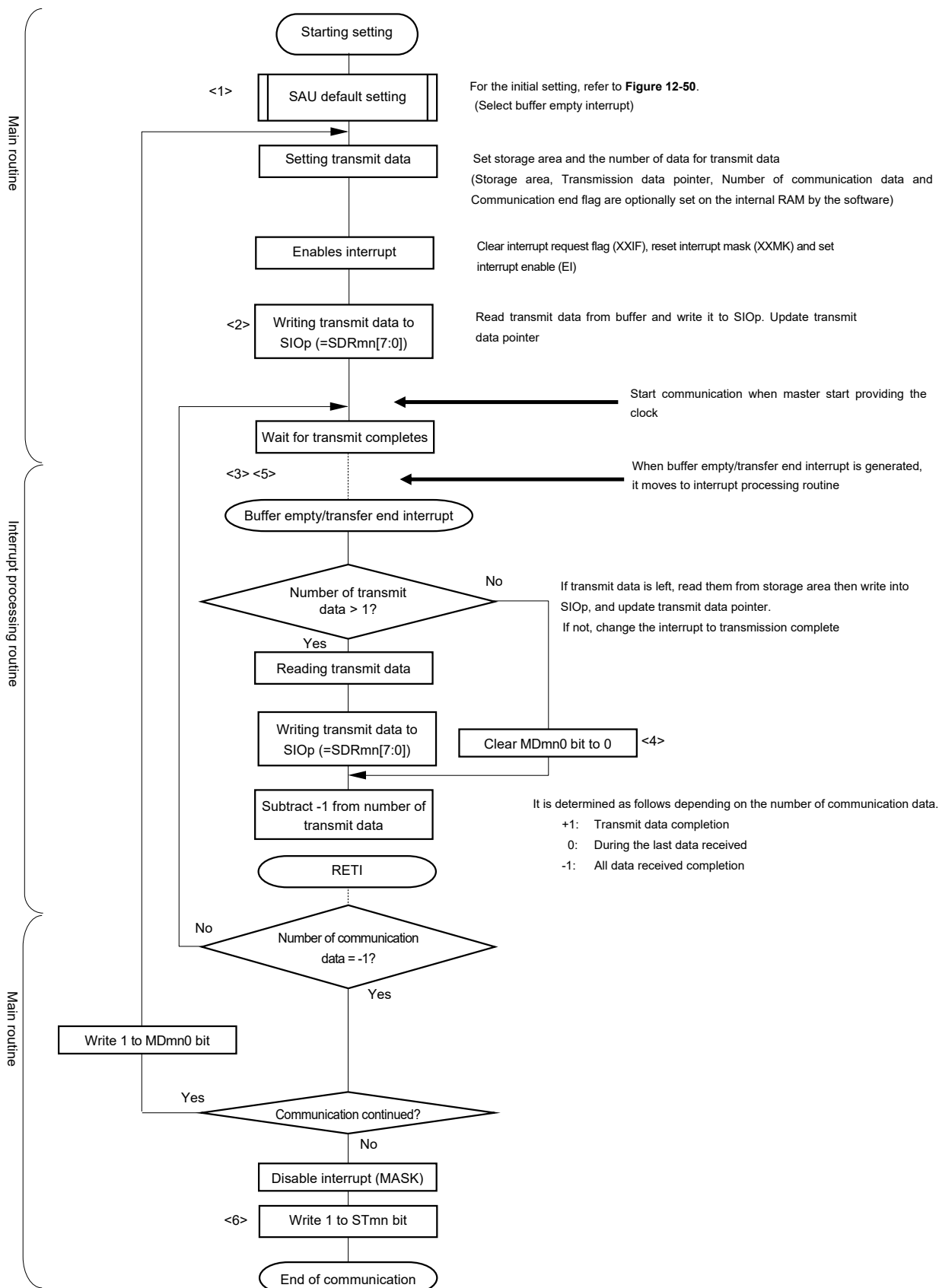

Remark <1> to <6> in the figure correspond to <1> to <6> in Figure 12-55 Timing Chart of Slave Transmission (in Continuous Transmission Mode).

12.5.5 Slave reception

Slave reception is that the RL78 microcontroller receives data from another device in the state of a transfer clock being input from another device.

Simplified SPI	CSI00	CSI01	CSI10	CSI11	CSI20	CSI21	CSI30	CSI31
Target channel	Channel 0 of SAU0	Channel 1 of SAU0	Channel 2 of SAU0	Channel 3 of SAU0	Channel 0 of SAU1	Channel 1 of SAU1	Channel 2 of SAU1	Channel 3 of SAU1
Pins used	SCK00, SI00	SCK01, SI01	SCK10, SI10	SCK11, SI11	SCK20, SI20	SCK21, SI21	SCK30, SI30	SCK31, SI31
Interrupt	INTCSI00	INTCSI01	INTCSI10	INTCSI11	INTCSI20	INTCSI21	INTCSI30	INTCSI31
Error detection flag	Transfer end interrupt only (Setting the buffer empty interrupt is prohibited.)							
Transfer data length	7 or 8 bits							
Transfer rate	Max. $f_{MCK}/6$ [Hz] ^{Notes 1, 2}							
Data phase	Selectable by the DAPmn bit of the SCRmn register <ul style="list-style-type: none"> • DAPmn = 0: Data input starts from the start of the operation of the serial clock. • DAPmn = 1: Data input starts half a clock before the start of the serial clock operation. 							
Clock phase	Selectable by the CKPmn bit of the SCRmn register <ul style="list-style-type: none"> • CKPmn = 0: Non-reverse • CKPmn = 1: Reverse 							
Data direction	MSB or LSB first							

Notes 1. Because the external serial clock input to the SCK00, SCK01, SCK10, SCK11, SCK20, SCK21, SCK30, and SCK31 pins is sampled internally and used, the fastest transfer rate is $f_{MCK}/6$ [Hz].

2. Use this operation within a range that satisfies the conditions above and the peripheral functions characteristics in the electrical specifications (see **CHAPTER 29 ELECTRICAL SPECIFICATIONS (T_A = -40 to +85°C)** and **CHAPTER 30 ELECTRICAL SPECIFICATIONS (G: INDUSTRIAL APPLICATIONS T_A = -40 to +105°C)**).

Remarks 1. f_{MCK} : Operation clock frequency of target channel

f_{SCK} : Serial clock frequency

2. m: Unit number (m = 0, 1), n: Channel number (n = 0 to 3), mn = 00 to 03, 10 to 13

(1) Register setting

Figure 12-57. Example of Contents of Registers for Slave Reception of simplified SPI (CSI00, CSI01, CSI10, CSI11, CSI20, CSI21, CSI30, CSI31) (1/2)

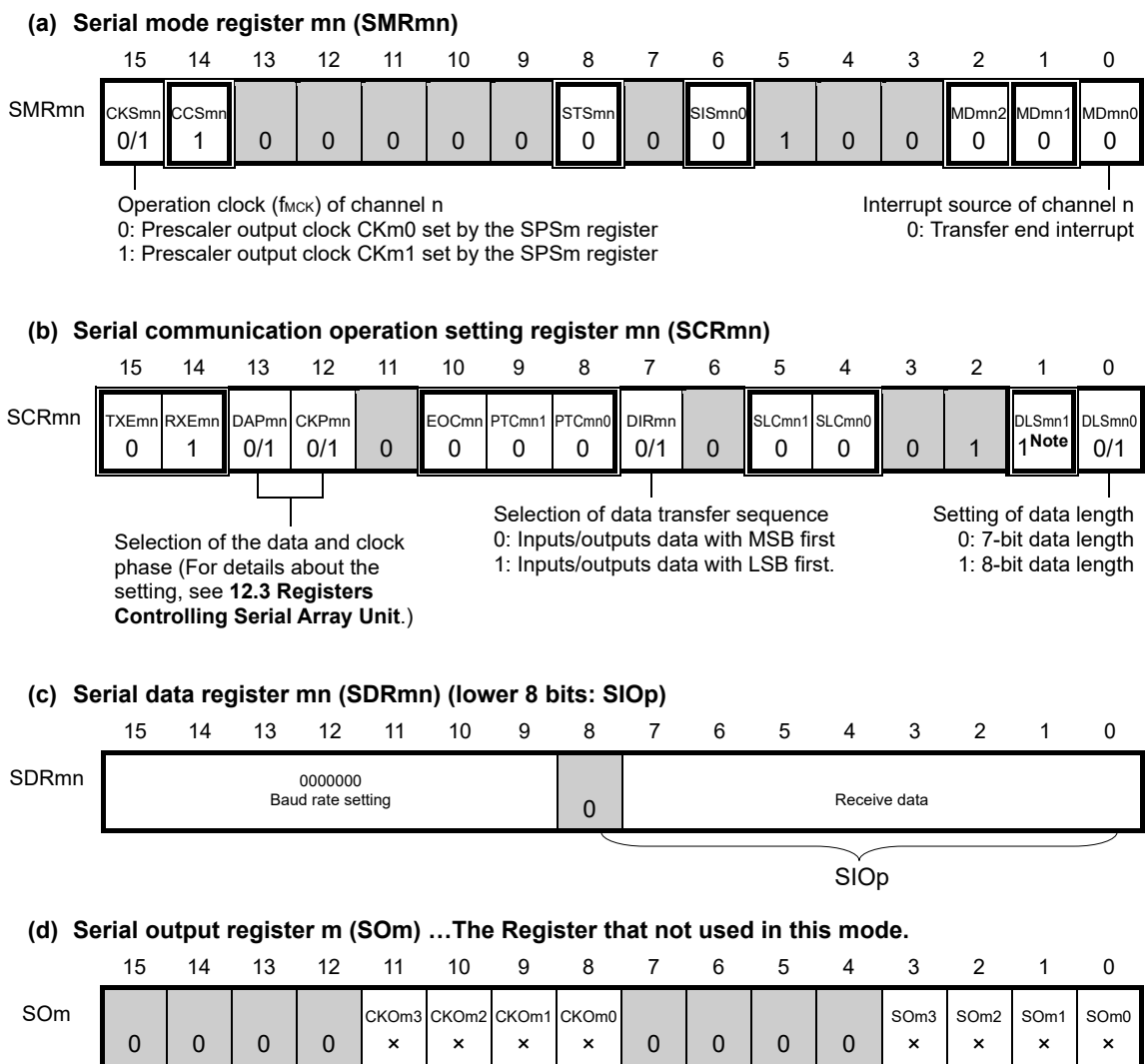

Note Only provided for the SCR00 and SCR01 registers and the SCR10 and SCR11 registers of an 80- to 128-pin product. This bit is fixed to 1 for the other registers.

- Remarks 1.** m: Unit number (m = 0, 1), n: Channel number (n = 0 to 3), p: CSI number (p = 00, 01, 10, 11, 20, 21, 30, 31), mn = 00 to 03, 10 to 13
- 2.** □: Setting is fixed in the simplified SPI (CSI) slave reception mode, ■: Setting disabled (set to the initial value)
 x: Bit that cannot be used in this mode (set to the initial value when not used in any mode)
 0/1: Set to 0 or 1 depending on the usage of the user

Figure 12-57. Example of Contents of Registers for Slave Reception of simplified SPI (CSI00, CSI01, CSI10, CSI11, CSI20, CSI21, CSI30, CSI31) (2/2)

(e) Serial output enable register m (SOEm) ...The Register that not used in this mode.

	15	14	13	12	11	10	9	8	7	6	5	4	3	2	1	0
SOEm	0	0	0	0	0	0	0	0	0	0	0	0	SOEm3	SOEm2	SOEm1	SOEm0
													x	x	x	x

(f) Serial channel start register m (SSm) ... Sets only the bits of the target channel to 1.

	15	14	13	12	11	10	9	8	7	6	5	4	3	2	1	0
SSm	0	0	0	0	0	0	0	0	0	0	0	0	SSm3	SSm2	SSm1	SSm0
													0/1	0/1	0/1	0/1

Remarks 1. m: Unit number (m = 0, 1)

2. : Setting disabled (set to the initial value)

x: Bit that cannot be used in this mode (set to the initial value when not used in any mode)

0/1: Set to 0 or 1 depending on the usage of the user

(2) Operation procedure

Figure 12-58. Initial Setting Procedure for Slave Reception

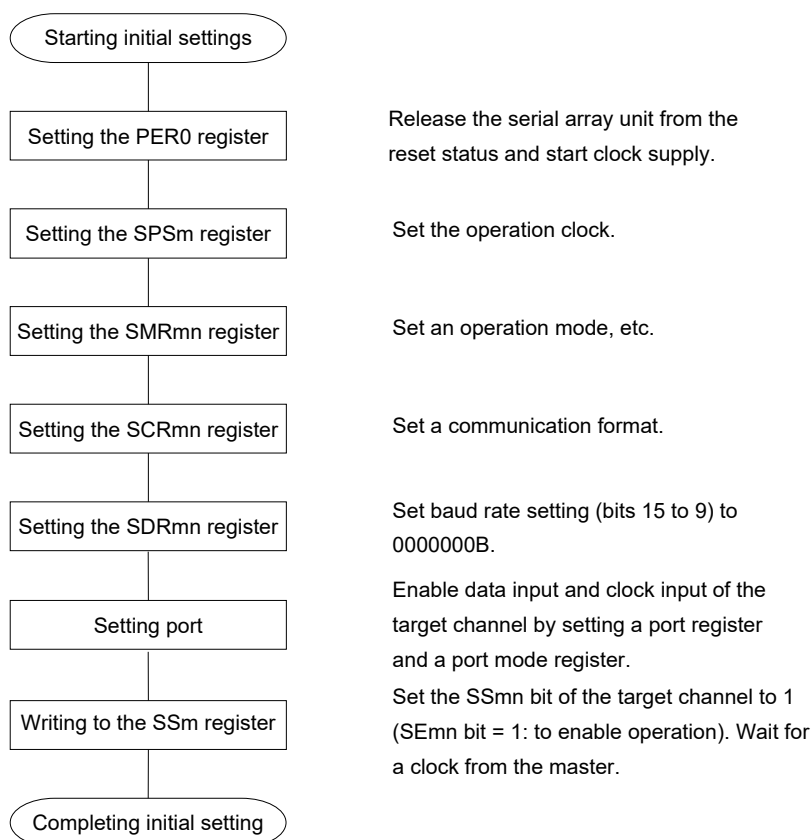

Figure 12-59. Procedure for Stopping Slave Reception

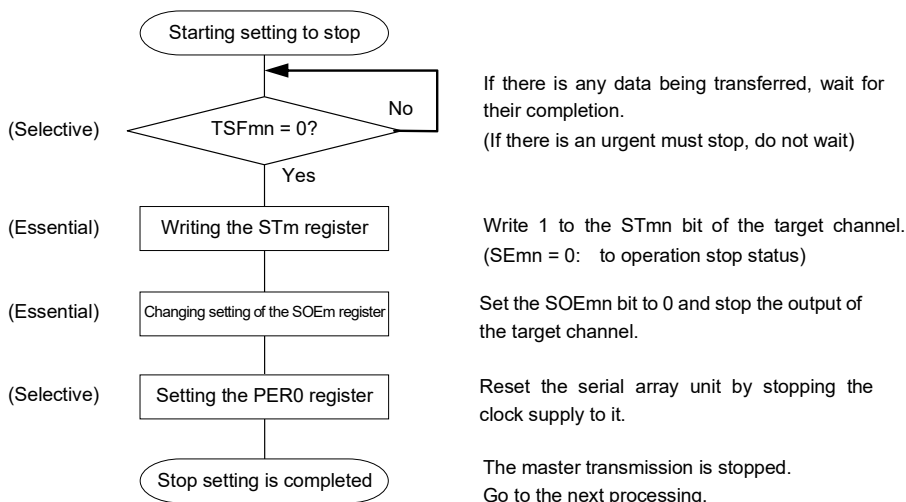
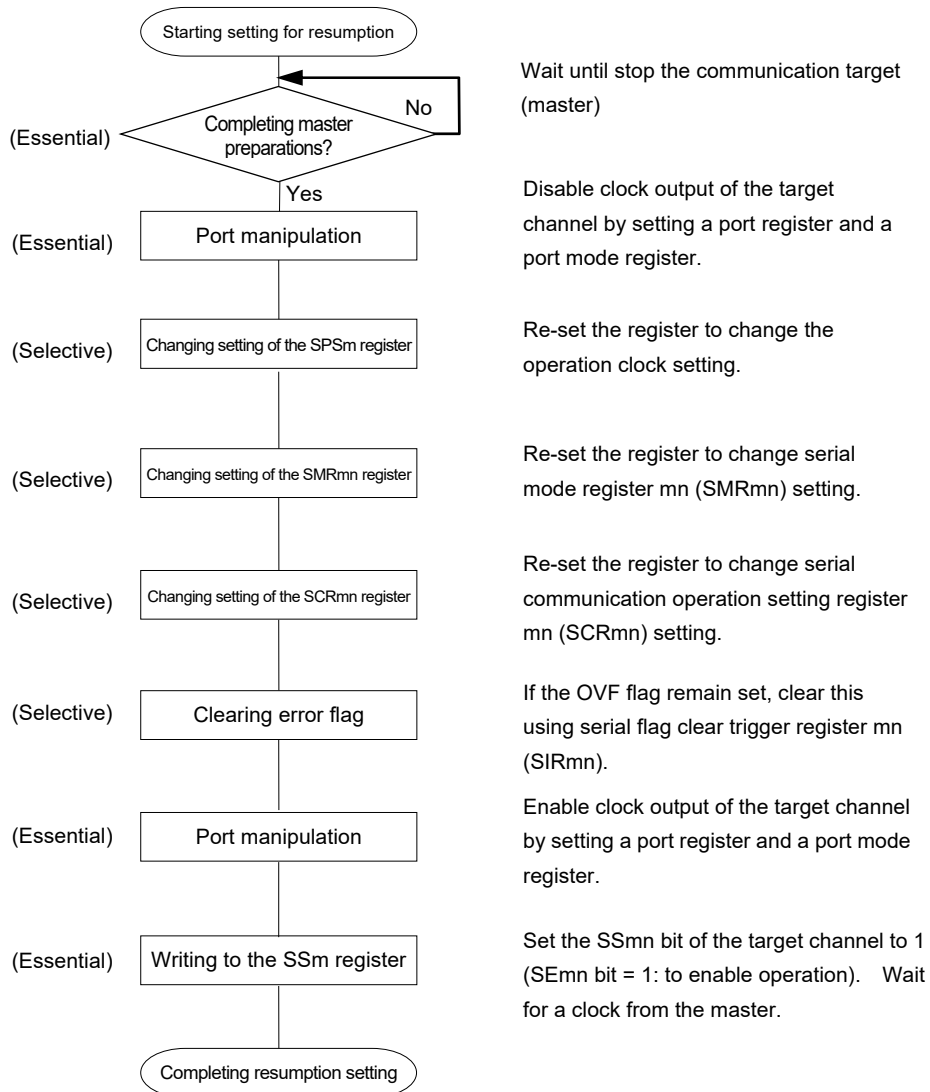

Figure 12-60. Procedure for Resuming Slave Reception



Remark If PER0 is rewritten while stopping the master transmission and the clock supply is stopped, wait until the transmission target (master) stops or transmission finishes, and then perform initialization instead of restarting the transmission.

(3) Processing flow (in single-reception mode)

Figure 12-61. Timing Chart of Slave Reception (in Single-Reception Mode)
 (Type 1: DAPmn = 0, CKPmn = 0)

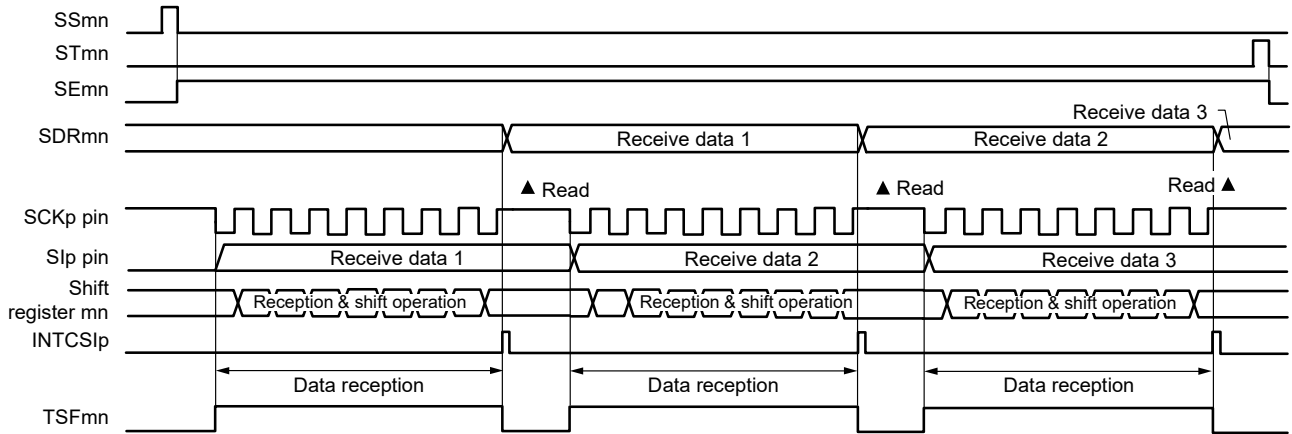

Remark m: Unit number (m = 0, 1), n: Channel number (n = 0 to 3), p: CSI number (p = 00, 01, 10, 11, 20, 21, 30, 31), mn = 00 to 03, 10 to 13

Figure 12-62. Flowchart of Slave Reception (in Single-Reception Mode)

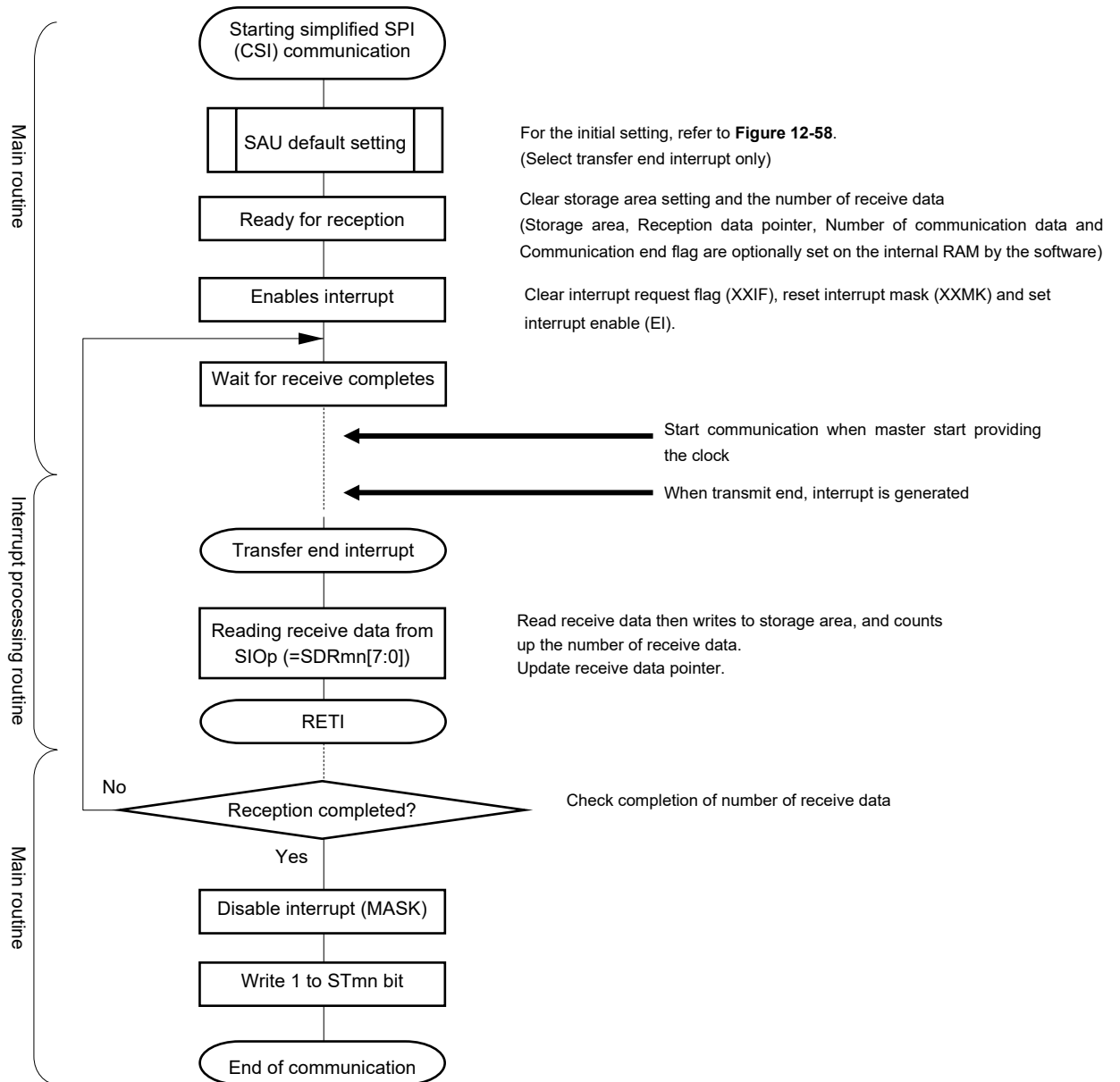

12.5.6 Slave transmission/reception

Slave transmission/reception is that the RL78 microcontroller transmits/receives data to/from another device in the state of a transfer clock being input from another device.

Simplified SPI	CSI00	CSI01	CSI10	CSI11	CSI20	CSI21	CSI30	CSI31
Target channel	Channel 0 of SAU0	Channel 1 of SAU0	Channel 2 of SAU0	Channel 3 of SAU0	Channel 0 of SAU1	Channel 1 of SAU1	Channel 2 of SAU1	Channel 3 of SAU1
Pins used	SCK00, SI00, SO00	SCK01, SI01, SO01	SCK10, SI10, SO10	SCK11, SI11, SO11	SCK20, SI20, SO20	SCK21, SI21, SO21	SCK30, SI30, SO30	SCK31, SI31, SO31
Interrupt	INTCSI00	INTCSI01	INTCSI10	INTCSI11	INTCSI20	INTCSI21	INTCSI30	INTCSI31
	Transfer end interrupt (in single-transfer mode) or buffer empty interrupt (in continuous transfer mode) can be selected.							
Error detection flag	Overrun error detection flag (OVFmn) only							
Transfer data length	7 or 8 bits							
Transfer rate	Max. $f_{mck}/6$ [Hz] Notes 1, 2.							
Data phase	Selectable by the DAPmn bit of the SCRmn register <ul style="list-style-type: none"> • DAPmn = 0: Data I/O starts from the start of the operation of the serial clock. • DAPmn = 1: Data I/O starts half a clock before the start of the serial clock operation. 							
Clock phase	Selectable by the CKPmn bit of the SCRmn register <ul style="list-style-type: none"> • CKPmn = 0: Non-reverse • CKPmn = 1: Reverse 							
Data direction	MSB or LSB first							

Notes 1. Because the external serial clock input to the SCK00, SCK01, SCK10, SCK11, SCK20, SCK21, SCK30, and SCK31 pins is sampled internally and used, the fastest transfer rate is $f_{mck}/6$ [Hz].

2. Use this operation within a range that satisfies the conditions above and the peripheral functions characteristics in the electrical specifications (see **CHAPTER 29 ELECTRICAL SPECIFICATIONS (T_A = -40 to +85°C)** and **CHAPTER 30 ELECTRICAL SPECIFICATIONS (G: INDUSTRIAL APPLICATIONS T_A = -40 to +105°C)**).

Remarks 1. f_{mck} : Operation clock frequency of target channel

f_{clk} : Serial clock frequency

2. m: Unit number (m = 0, 1), n: Channel number (n = 0 to 3), mn = 00 to 03, 10 to 13

(1) Register setting

Figure 12-63. Example of Contents of Registers for Slave Transmission/Reception of simplified SPI (CSI00, CSI01, CSI10, CSI11, CSI20, CSI21, CSI30, CSI31) (1/2)

(a) Serial mode register mn (SMRmn)

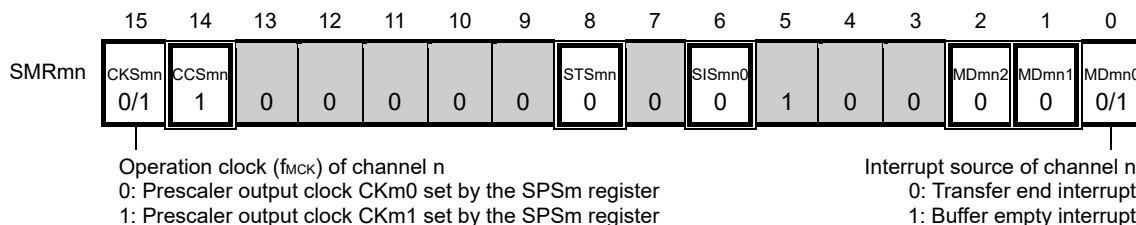

(b) Serial communication operation setting register mn (SCRmn)

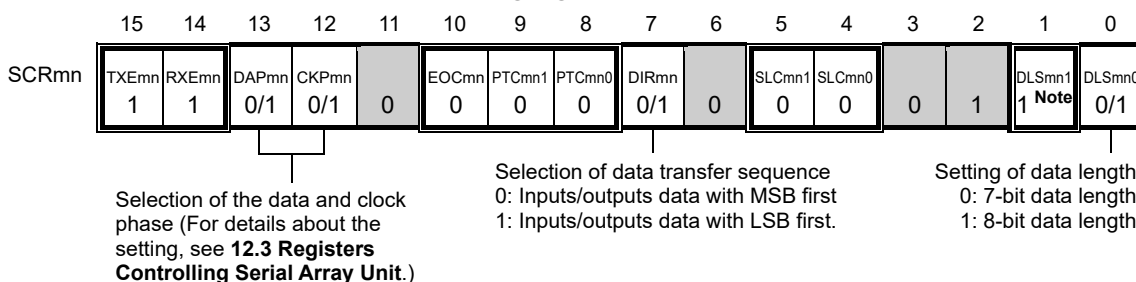

(c) Serial data register mn (SDRmn) (lower 8 bits: SIOp)

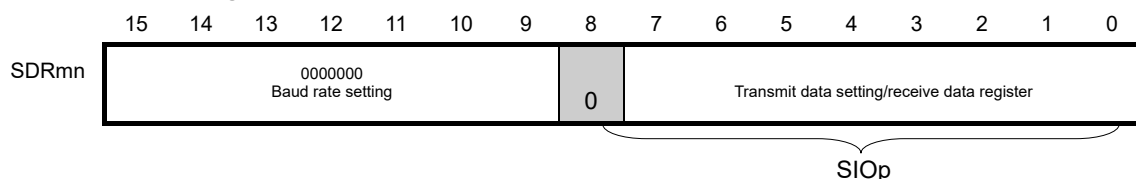

(d) Serial output register m (SOM) ... Sets only the bits of the target channel.

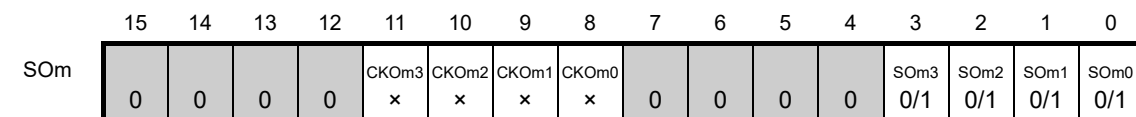

Note Only provided for the SCR00 and SCR01 registers and the SCR10 and SCR11 registers of an 80- to 128-pin product. This bit is fixed to 1 for the other registers.

Caution Be sure to set transmit data to the SIOp register before the clock from the master is started.

- Remarks**
- m: Unit number (m = 0, 1), n: Channel number (n = 0 to 3), p: CSI number (p = 00, 01, 10, 11, 20, 21, 30, 31), mn = 00 to 03, 10 to 13
 - : Setting is fixed in the simplified SPI (CSI) slave transmission/reception mode,
 ■: Setting disabled (set to the initial value)
 x: Bit that cannot be used in this mode (set to the initial value when not used in any mode)
 0/1: Set to 0 or 1 depending on the usage of the user

Figure 12-63. Example of Contents of Registers for Slave Transmission/Reception of simplified SPI (CSI00, CSI01, CSI10, CSI11, CSI20, CSI21, CSI30, CSI31) (2/2)

(e) Serial output enable register m (SOEm) ... Sets only the bits of the target channel to 1.

	15	14	13	12	11	10	9	8	7	6	5	4	3	2	1	0
SOEm	0	0	0	0	0	0	0	0	0	0	0	0	SOEm3	SOEm2	SOEm1	SOEm0
													0/1	0/1	0/1	0/1

(f) Serial channel start register m (SSm) ... Sets only the bits of the target channel to 1.

	15	14	13	12	11	10	9	8	7	6	5	4	3	2	1	0
SSm	0	0	0	0	0	0	0	0	0	0	0	0	SSm3	SSm2	SSm1	SSm0
													0/1	0/1	0/1	0/1

- Remarks**
- m: Unit number (m = 0, 1)
 - : Setting disabled (set to the initial value)
0/1: Set to 0 or 1 depending on the usage of the user

(2) Operation procedure

Figure 12-64. Initial Setting Procedure for Slave Transmission/Reception

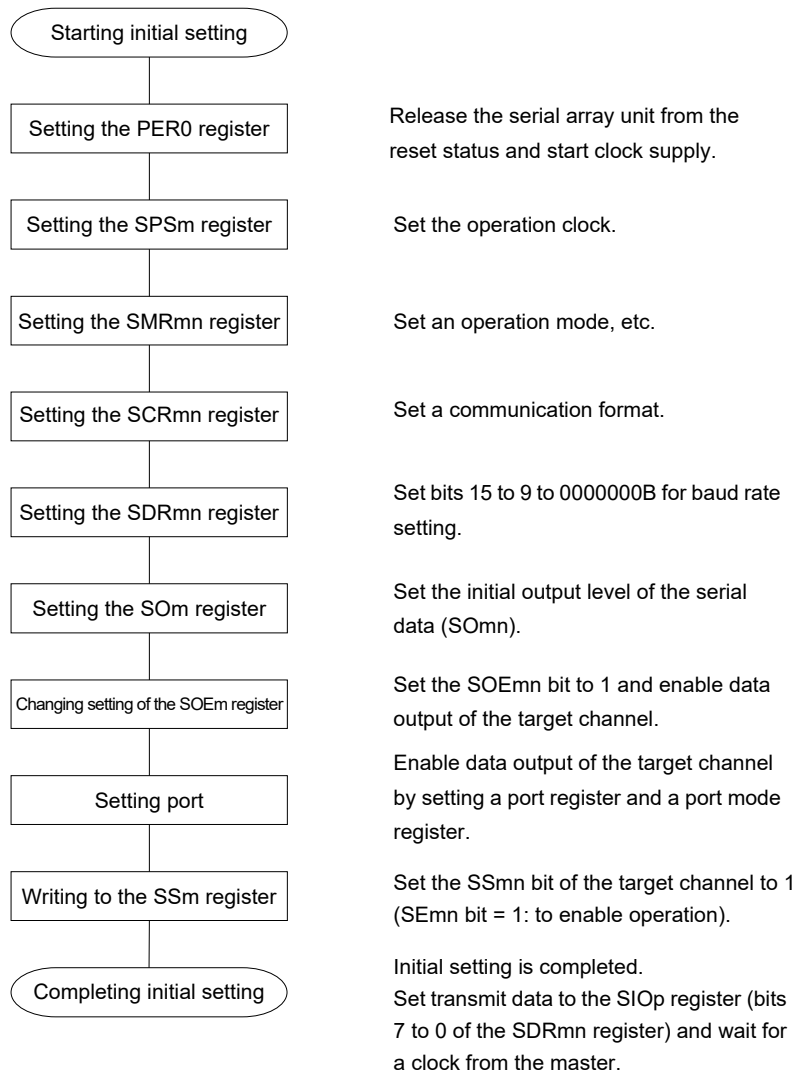

Figure 12-65. Procedure for Stopping Slave Transmission/Reception

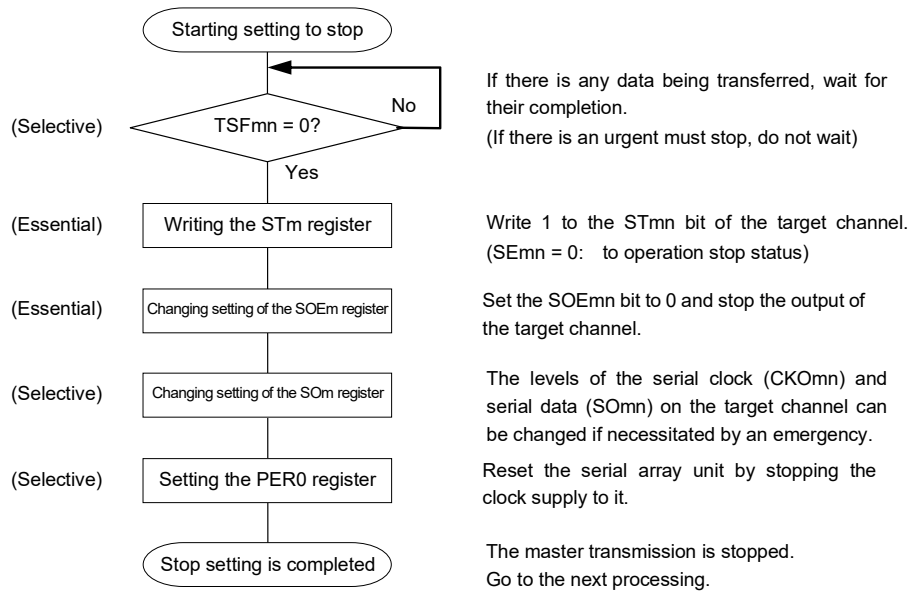
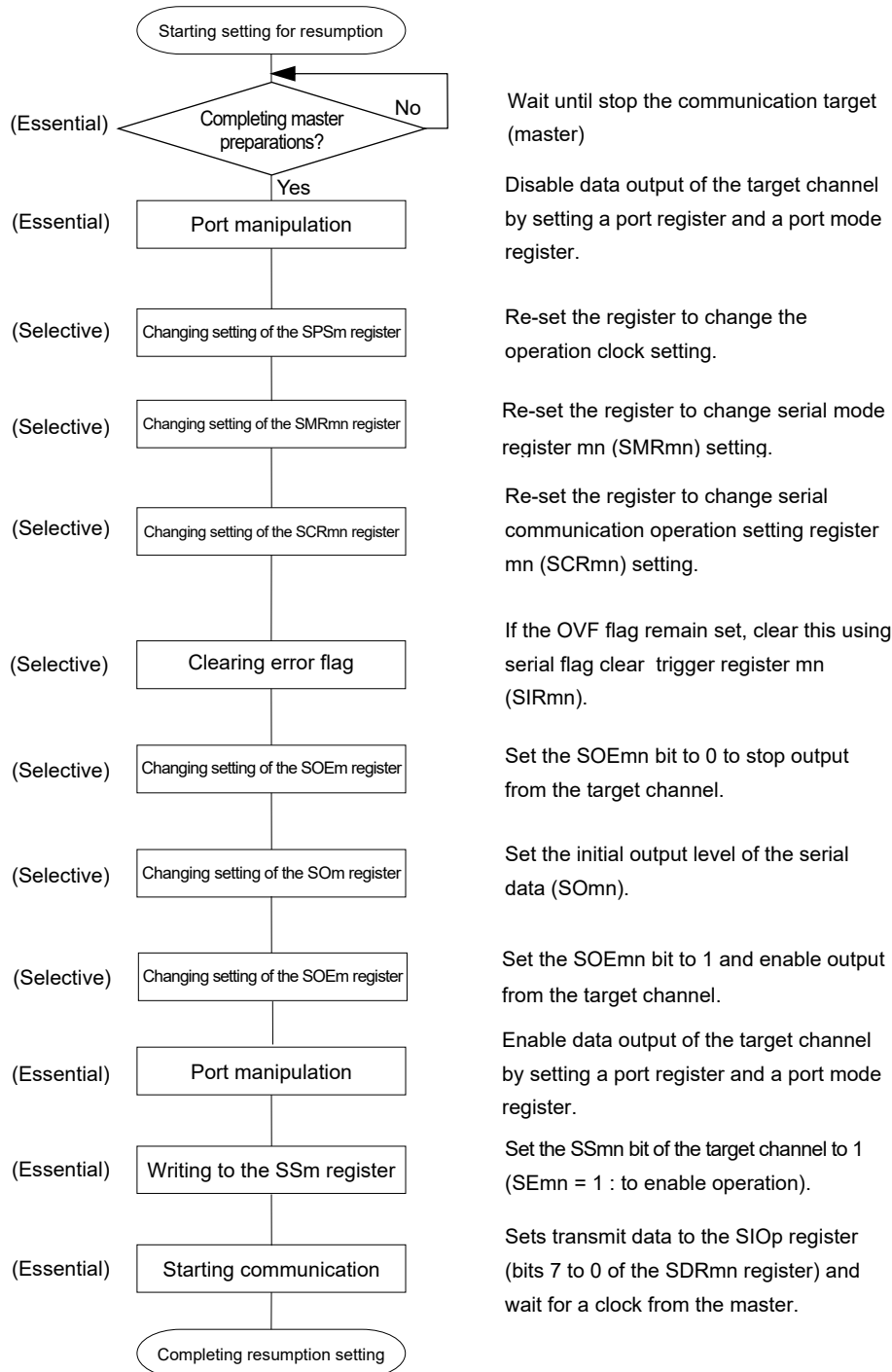

Figure 12-66. Procedure for Resuming Slave Transmission/Reception



- Cautions**
1. Be sure to set transmit data to the SIOp register before the clock from the master is started.
 2. If PER0 is rewritten while stopping the master transmission and the clock supply is stopped, wait until the transmission target (master) stops or transmission finishes, and then perform initialization instead of restarting the transmission.

(3) Processing flow (in single-transmission/reception mode)

Figure 12-67. Timing Chart of Slave Transmission/Reception (in Single-Transmission/Reception Mode)
 (Type 1: DAPmn = 0, CKPmn = 0)

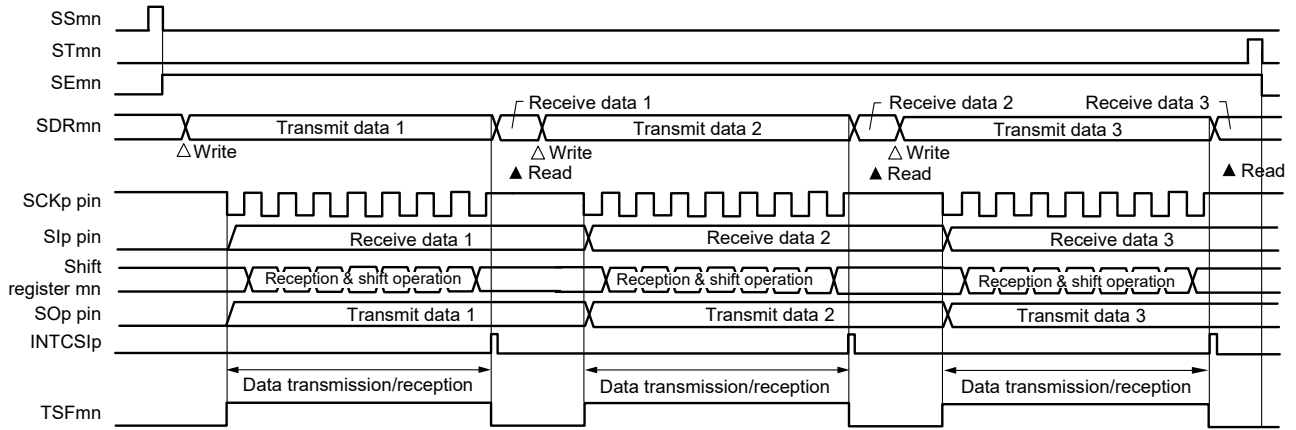

Remark m: Unit number (m = 0, 1), n: Channel number (n = 0 to 3), p: CSI number (p = 00, 01, 10, 11, 20, 21, 30, 31), mn = 00 to 03, 10 to 13

Figure 12-68. Flowchart of Slave Transmission/Reception (in Single-Transmission/Reception Mode)

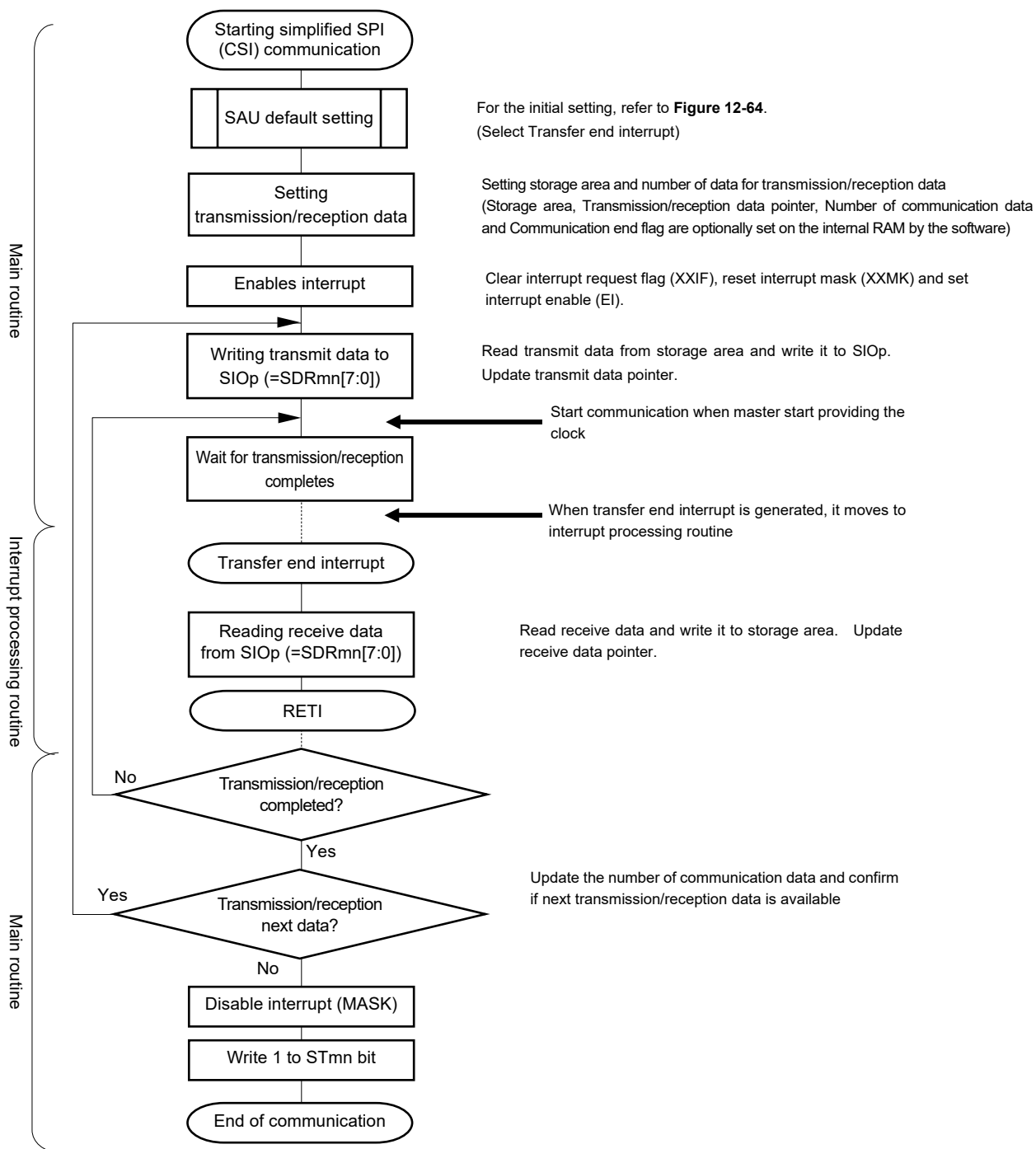

Caution Be sure to set transmit data to the SIOp register before the clock from the master is started.

(4) Processing flow (in continuous transmission/reception mode)

Figure 12-69. Timing Chart of Slave Transmission/Reception (in Continuous Transmission/Reception Mode)
(Type 1: DAPmn = 0, CKPmn = 0)

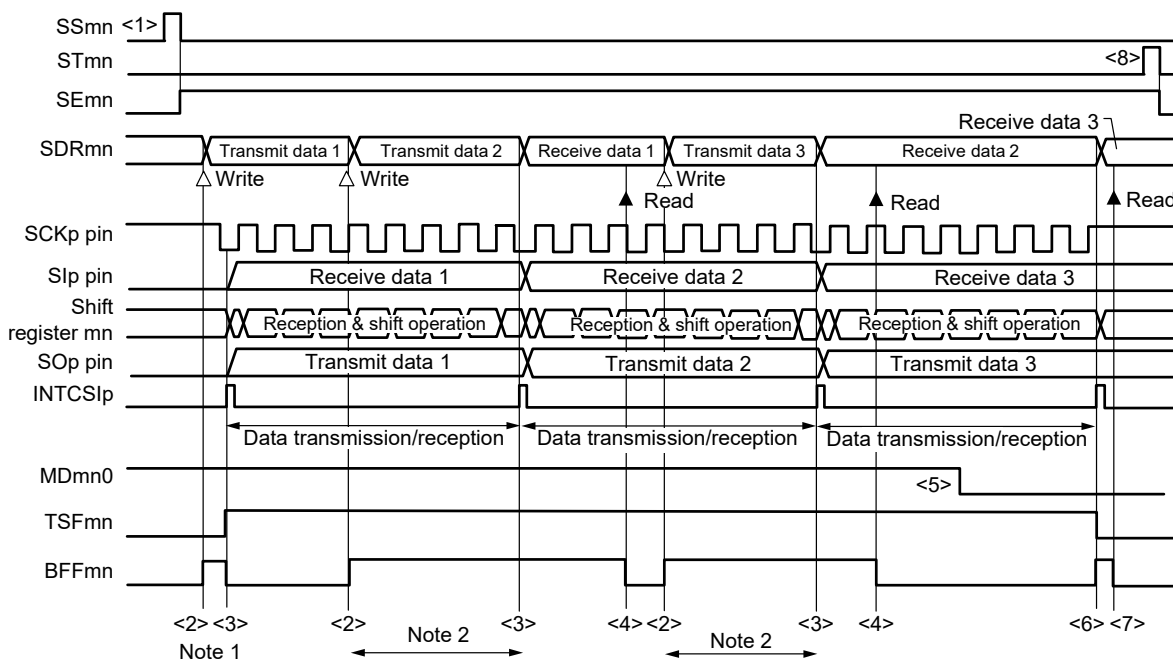

- Notes**
1. If transmit data is written to the SDRmn register while the BFFmn bit of serial status register mn (SSRmn) is 1 (valid data is stored in serial data register mn (SDRmn)), the transmit data is overwritten.
 2. The transmit data can be read by reading the SDRmn register during this period. At this time, the transfer operation is not affected.

Caution The MDmn0 bit of serial mode register mn (SMRmn) can be rewritten even during operation. However, rewrite it before transfer of the last bit is started, so that it has been rewritten before the transfer end interrupt of the last transmit data.

- Remarks**
1. <1> to <8> in the figure correspond to <1> to <8> in Figure 12-70 Flowchart of Slave Transmission/Reception (in Continuous Transmission/Reception Mode).
 2. m: Unit number (m = 0, 1), n: Channel number (n = 0 to 3), p: CSI number (p = 00, 01, 10, 11, 20, 21, 30, 31), mn = 00 to 03, 10 to 13

Figure 12-70. Flowchart of Slave Transmission/Reception (in Continuous Transmission/Reception Mode)

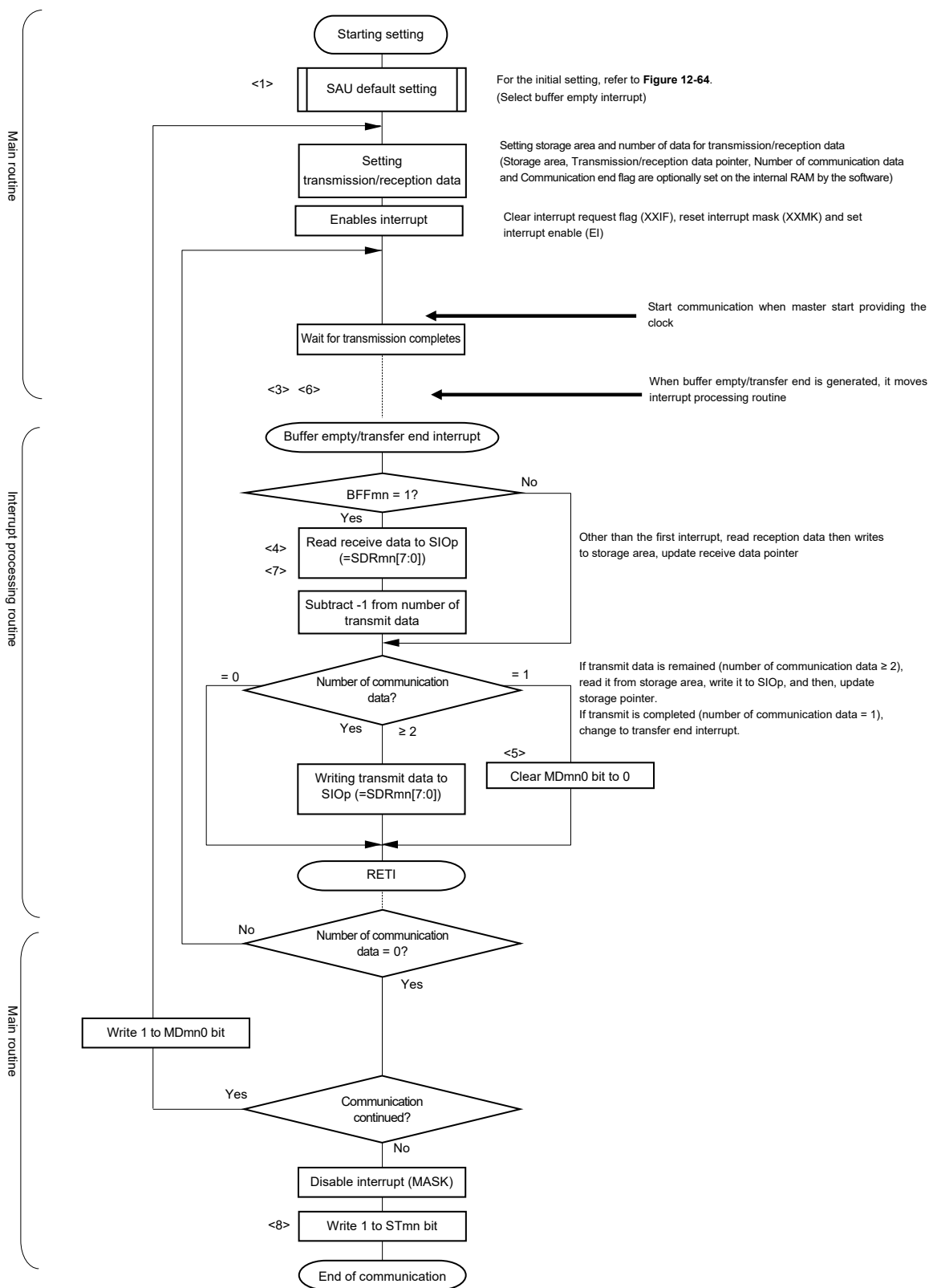

Caution Be sure to set transmit data to the SIOp register before the clock from the master is started.

Remark <1> to <8> in the figure correspond to <1> to <8> in Figure 12-69 Timing Chart of Slave Transmission/Reception (in Continuous Transmission/Reception Mode).

12.5.7 SNOOZE mode function

The SNOOZE mode makes the simplified SPI (CSI) perform reception operations upon SCKp pin input detection while in the STOP mode. Normally the simplified SPI (CSI) stops communication in the STOP mode. However, using the SNOOZE mode enables the simplified SPI (CSI) to perform reception operations without CPU operation upon detection of the SCKp pin input.

Only the following channels can be set to the SNOOZE mode.

- 20 to 64-pin products: CSI00
- 80 to 128-pin products: CSI00 and CSI20

When using the simplified SPI (CSI) in SNOOZE mode, make the following setting before switching to the STOP mode (see **Figure 12-72 Flowchart of SNOOZE Mode Operation (once startup)** and **Figure 12-74 Flowchart of SNOOZE Mode Operation (continuous startup)**).

- When using the SNOOZE mode function, set the SWCm bit of serial standby control register m (SSCm) to 1 just before switching to the STOP mode. After the initial setting has been completed, set the SSm0 bit of serial channel start register m (SSm) to 1.
- The CPU shifts to the SNOOZE mode on detecting the valid edge of the SCKp signal following a transition to the STOP mode. A CSIp starts reception on detecting input of the serial clock on the SCKp pin.

- Cautions 1. The SNOOZE mode can only be specified when the high-speed on-chip oscillator clock is selected for fCLK.**
- 2. The maximum transfer rate when using CSIp in the SNOOZE mode is 1 Mbps.**

(1) SNOOZE mode operation (once startup)

Figure 12-71. Timing Chart of SNOOZE Mode Operation (once startup) (Type 1: DAPmn = 0, CKPmn = 0)

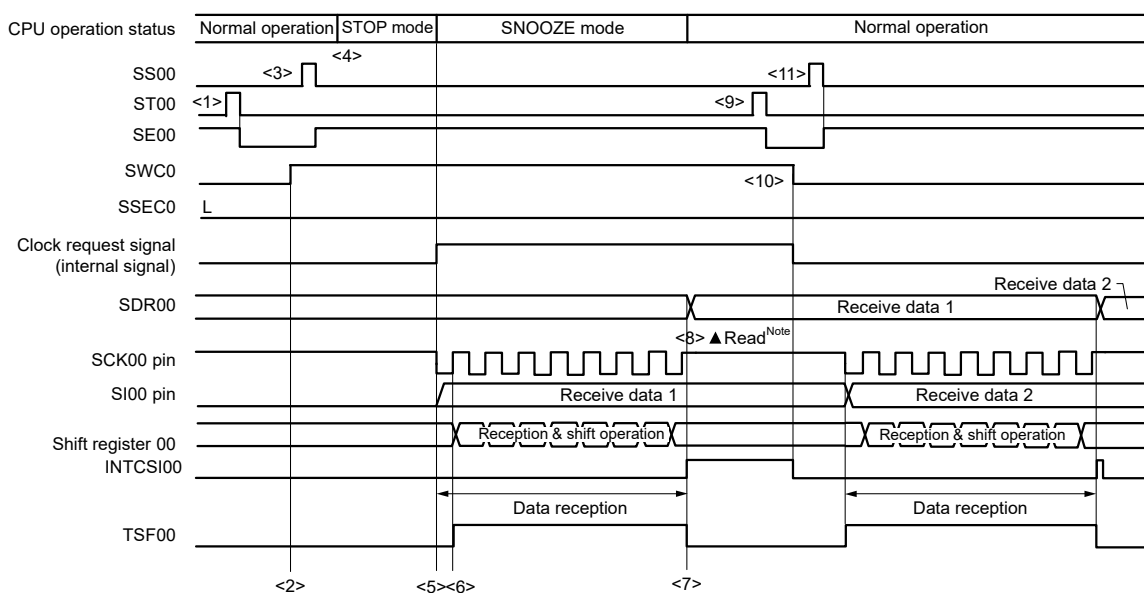

Note Only read received data while SWCm = 1 and before the next valid edge of the SCKp pin input is detected.

- Cautions 1. Before switching to the SNOOZE mode or after reception operation in the SNOOZE mode finishes, set the STm0 bit to 1 (clear the SEm0 bit and stop the operation). After the receive operation completes, also clear the SWCm bit to 0 (SNOOZE mode release).**
- 2. When SWCm = 1, the BFFm0 and OVfm0 flags will not change.**

- Remarks 1. <1> to <11> in the figure correspond to <1> to <11> in Figure 12-72 Flowchart of SNOOZE Mode Operation (once startup).**
- 2. 20 to 64-pin products: m = 0; p = 00**
80 to 128-pin products: m = 0, 1; p = 00, 20

Figure 12-72. Flowchart of SNOOZE Mode Operation (once startup)

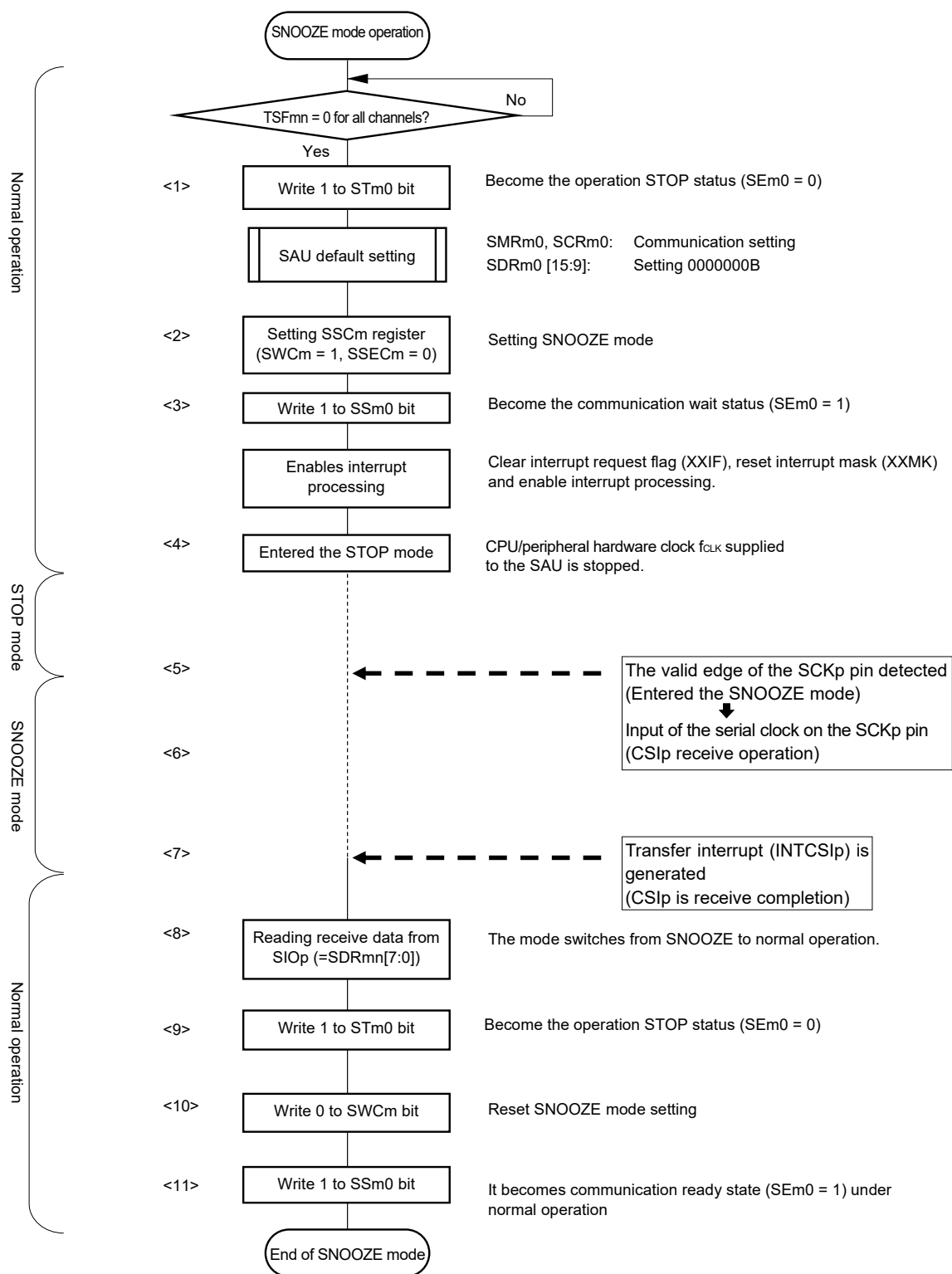

Remarks 1. <1> to <11> in the figure correspond to <1> to <11> in Figure 12-71 Timing Chart of SNOOZE Mode Operation (once startup) (Type 1: DAPmn = 0, CKPmn = 0).

- 20 to 64-pin products: m = 0; p = 00
80 to 128-pin products: m = 0, 1; p = 00, 20

(2) SNOOZE mode operation (continuous startup)

Figure 12-73. Timing Chart of SNOOZE Mode Operation (continuous startup) (Type 1: DAPmn = 0, CKPmn = 0)

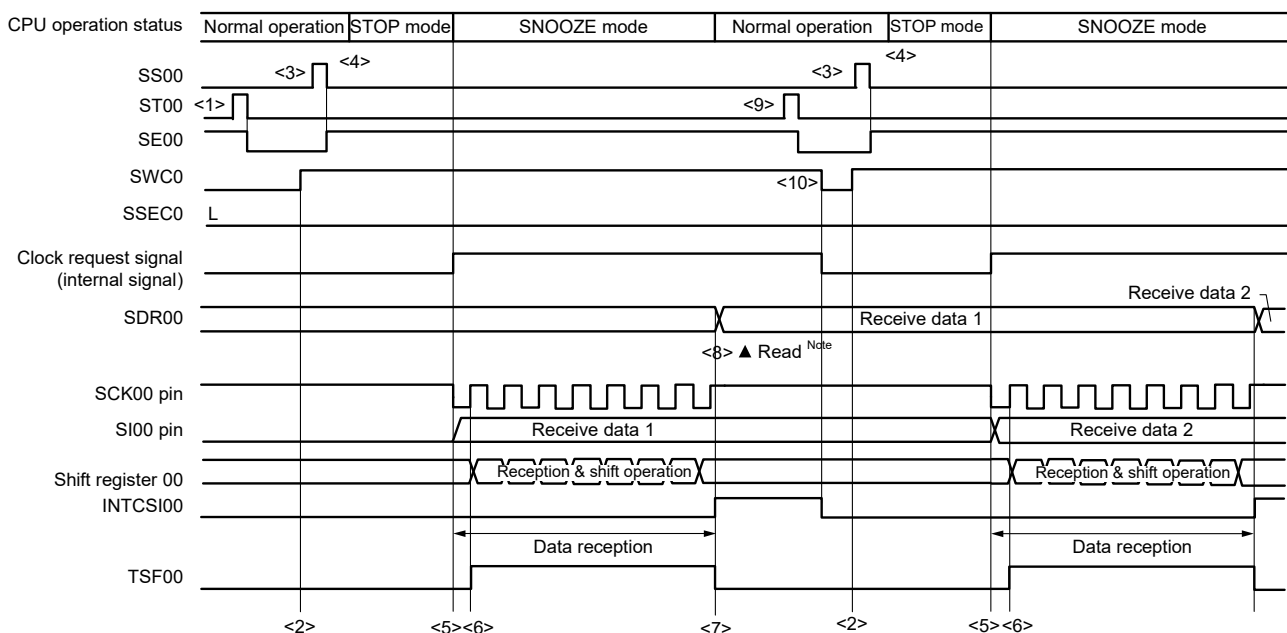

Note Only read received data while SWCm = 1 and before the next valid edge of the SCKp pin input is detected.

- Cautions**
1. Before switching to the SNOOZE mode or after reception operation in the SNOOZE mode finishes, set the STm0 bit to 1 (clear the SEm0 bit and stop the operation). After the receive operation completes, also clear the SWCm bit to 0 (SNOOZE mode release).
 2. When SWCm = 1, the BFFm0 and OVfm0 flags will not change.

- Remarks**
1. <1> to <10> in the figure correspond to <1> to <10> in Figure 12-74 Flowchart of SNOOZE Mode Operation (continuous startup).
 2. 20 to 64-pin products: m = 0; p = 00
80 to 128-pin products: m = 0, 1; p = 00, 20

Figure 12-74. Flowchart of SNOOZE Mode Operation (continuous startup)

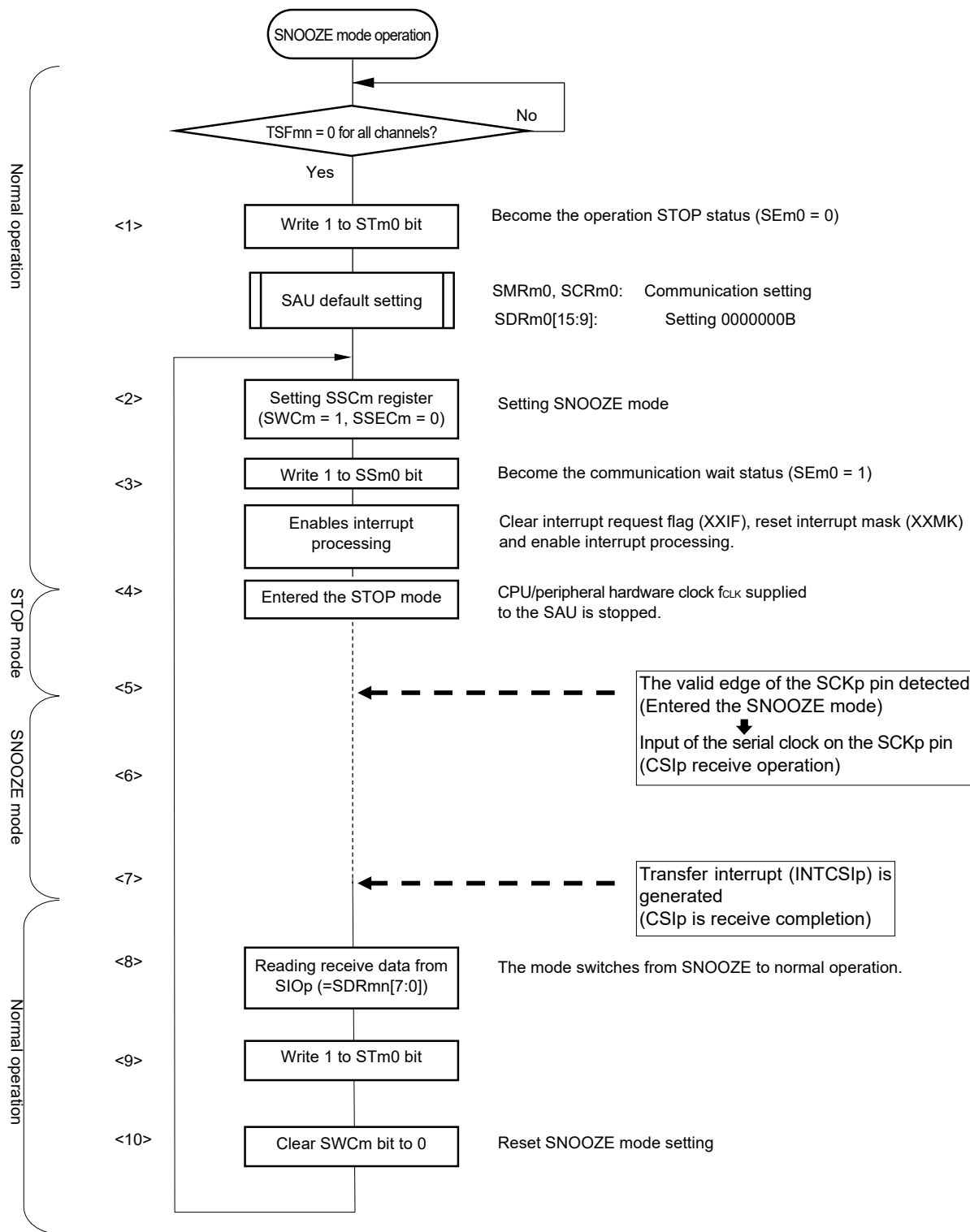

Remarks 1. <1> to <10> in the figure correspond to <1> to <10> in Figure 12-73 Timing Chart of SNOOZE Mode Operation (continuous startup) (Type 1: DAPmn = 0, CKPmn = 0).

- 2. 20 to 64-pin products: m = 0; p = 00
- 80 to 128-pin products: m = 0, 1; p = 00, 20

12.5.8 Calculating transfer clock frequency

The transfer clock frequency for simplified SPI (CSI00, CSI01, CSI10, CSI11, CSI20, CSI21, CSI30, CSI31) communication can be calculated by the following expressions.

(1) Master

$$\text{(Transfer clock frequency)} = \{\text{Operation clock (f}_{MCK}\text{) frequency of target channel}\} \div (\text{SDRmn}[15:9] + 1) \div 2 \text{ [Hz]}$$

(2) Slave

$$\text{(Transfer clock frequency)} = \{\text{Frequency of serial clock (SCK) supplied by master}\}^{\text{Note}} \text{ [Hz]}$$

Note The permissible maximum transfer clock frequency is $f_{MCK}/6$.

Remark The value of SDRmn[15:9] is the value of bits 15 to 9 of serial data register mn (SDRmn) (0000000B to 1111111B) and therefore is 0 to 127.

The operation clock (f_{MCK}) is determined by serial clock select register m (SPSm) and bit 15 (CKSmn) of serial mode register mn (SMRmn).

Table 12-2. Selection of Operation Clock For Simplified SPI

SMRmn Register	SPSm Register								Operation Clock (f _{CLK}) ^{Note}	
	CKSmn	PRSm13	PRSm12	PRSm11	PRSm10	PRSm03	PRSm02	PRSm01	PRSm00	f _{CLK} = 32 MHz
0	X	X	X	X	0	0	0	0	f _{CLK}	32 MHz
	X	X	X	X	0	0	0	1	f _{CLK} /2	16 MHz
	X	X	X	X	0	0	1	0	f _{CLK} /2 ²	8 MHz
	X	X	X	X	0	0	1	1	f _{CLK} /2 ³	4 MHz
	X	X	X	X	0	1	0	0	f _{CLK} /2 ⁴	2 MHz
	X	X	X	X	0	1	0	1	f _{CLK} /2 ⁵	1 MHz
	X	X	X	X	0	1	1	0	f _{CLK} /2 ⁶	500 kHz
	X	X	X	X	0	1	1	1	f _{CLK} /2 ⁷	250 kHz
	X	X	X	X	1	0	0	0	f _{CLK} /2 ⁸	125 kHz
	X	X	X	X	1	0	0	1	f _{CLK} /2 ⁹	62.5 kHz
	X	X	X	X	1	0	1	0	f _{CLK} /2 ¹⁰	31.25 kHz
	X	X	X	X	1	0	1	1	f _{CLK} /2 ¹¹	15.63 kHz
	X	X	X	X	1	1	0	0	f _{CLK} /2 ¹²	7.81 kHz
	X	X	X	X	1	1	0	1	f _{CLK} /2 ¹³	3.91 kHz
	X	X	X	X	1	1	1	0	f _{CLK} /2 ¹⁴	1.95 kHz
X	X	X	X	1	1	1	1	f _{CLK} /2 ¹⁵	977 Hz	
1	0	0	0	0	X	X	X	X	f _{CLK}	32 MHz
	0	0	0	1	X	X	X	X	f _{CLK} /2	16 MHz
	0	0	1	0	X	X	X	X	f _{CLK} /2 ²	8 MHz
	0	0	1	1	X	X	X	X	f _{CLK} /2 ³	4 MHz
	0	1	0	0	X	X	X	X	f _{CLK} /2 ⁴	2 MHz
	0	1	0	1	X	X	X	X	f _{CLK} /2 ⁵	1 MHz
	0	1	1	0	X	X	X	X	f _{CLK} /2 ⁶	500 kHz
	0	1	1	1	X	X	X	X	f _{CLK} /2 ⁷	250 kHz
	1	0	0	0	X	X	X	X	f _{CLK} /2 ⁸	125 kHz
	1	0	0	1	X	X	X	X	f _{CLK} /2 ⁹	62.5 kHz
	1	0	1	0	X	X	X	X	f _{CLK} /2 ¹⁰	31.25 kHz
	1	0	1	1	X	X	X	X	f _{CLK} /2 ¹¹	15.63 kHz
	1	1	0	0	X	X	X	X	f _{CLK} /2 ¹²	7.81 kHz
	1	1	0	1	X	X	X	X	f _{CLK} /2 ¹³	3.91 kHz
	1	1	1	0	X	X	X	X	f _{CLK} /2 ¹⁴	1.95 kHz
1	1	1	1	X	X	X	X	f _{CLK} /2 ¹⁵	977 Hz	
Other than above									Setting prohibited	

Note When changing the clock selected for f_{CLK} (by changing the system clock control register (CKC) value), do so after having stopped (serial channel stop register m (STm) = 000FH) the operation of the serial array unit (SAU).

Remarks 1. X: Don't care

2. m: Unit number (m = 0, 1), n: Channel number (n = 0 to 3), mn = 00 to 03, 10 to 13

12.5.9 Procedure for processing errors that occurred during simplified SPI (CSI00, CSI01, CSI10, CSI11, CSI20, CSI21, CSI30, CSI31) communication

The procedure for processing errors that occurred during simplified SPI (CSI00, CSI01, CSI10, CSI11, CSI20, CSI21, CSI30, CSI31) communication is described in Figure 12-75.

Figure 12-75. Processing Procedure in Case of Overrun Error

Software Manipulation	Hardware Status	Remark
Reads serial data register mn (SDRmn).	→ The BFFmn bit of the SSRmn register is set to 0 and channel n is enabled to receive data.	This is to prevent an overrun error if the next reception is completed during error processing.
Reads serial status register mn (SSRmn).		The error type is identified and the read value is used to clear the error flag.
Writes 1 to serial flag clear trigger register mn (SIRmn).	→ The error flag is cleared.	The error can be cleared only during reading, by writing the value read from the SSRmn register to the SIRmn register without modification.

Remark m: Unit number (m = 0, 1), n: Channel number (n = 0 to 3), mn = 00 to 03, 10 to 13

12.6 Operation of UART (UART0 to UART3) Communication

This is a start-stop synchronization function using two lines: serial data transmission (TxD) and serial data reception (RxD) lines. By using these two communication lines, each data frame, which consist of a start bit, data, parity bit, and stop bit, is transferred asynchronously (using the internal baud rate) between the microcontroller and the other communication party. Full-duplex asynchronous communication UART communication can be performed by using a channel dedicated to transmission (even-numbered channel) and a channel dedicated to reception (odd-numbered channel). The LIN-bus can be implemented by using UART2, timer array unit 0 (channel 7), and an external interrupt (INTP0).

[Data transmission/reception]

- Data length of 7, 8, or 9 bits ^{Note}
- Select the MSB/LSB first
- Level setting of transmit/receive data (selecting whether to reverse the level)
- Parity bit appending and parity check functions
- Stop bit appending, stop bit check function

[Interrupt function]

- Transfer end interrupt/buffer empty interrupt
- Error interrupt in case of framing error, parity error, or overrun error

[Error detection flag]

- Framing error, parity error, or overrun error

In addition, UART0 reception (channel 1 of unit 0) supports the SNOOZE mode. When RxD0 pin input is detected while in the STOP mode, the SNOOZE mode makes data reception that does not require the CPU possible. Only the following UARTs can be specified for the reception baud rate adjustment function.

- 20 to 64-pin products: UART0
- 80 to 128-pin products: UART0 and UART2

The LIN-bus is accepted in UART2 (channels 0 and 1 of unit 1) (30-pin to 128-pin products only).

[LIN-bus functions]

- Wakeup signal detection
- Break field (BF) detection
- Sync field measurement, baud rate calculation

} Using the external interrupt (INTP0) and timer array unit 0 (channel 7)

Note Only the following UARTs can be specified for the 9-bit data length.

- 20 to 64-pin products: UART0
- 80 to 128-pin products: UART0 and UART2

UART0 uses channels 0 and 1 of SAU0.

UART1 uses channels 2 and 3 of SAU0.

UART2 uses channels 0 and 1 of SAU1.

UART3 uses channels 2 and 3 of SAU1.

- 20, 24, and 25-pin products

Unit	Channel	Used as simplified SPI (CSI)	Used as UART	Used as Simplified I ² C
0	0	CSI00	UART0	IIC00
	1	–		–
	2	–	UART1	–
	3	CSI11		IIC11

- 30, 32-pin products

Unit	Channel	Used as simplified SPI (CSI)	Used as UART	Used as Simplified I ² C
0	0	CSI00	UART0	IIC00
	1	–		–
	2	–	UART1	–
	3	CSI11		IIC11
1	0	CSI20	UART2 (supporting LIN-bus)	IIC20
	1	–		–

- 36, 40, 44-pin products

Unit	Channel	Used as simplified SPI (CSI)	Used as UART	Used as Simplified I ² C
0	0	CSI00	UART0	IIC00
	1	–		–
	2	–	UART1	–
	3	CSI11		IIC11
1	0	CSI20	UART2 (supporting LIN-bus)	IIC20
	1	CSI21		IIC21

- 48, 52-pin products

Unit	Channel	Used as simplified SPI (CSI)	Used as UART	Used as Simplified I ² C
0	0	CSI00	UART0	IIC00
	1	CSI01		IIC01
	2	–	UART1	–
	3	CSI11		IIC11
1	0	CSI20	UART2 (supporting LIN-bus)	IIC20
	1	CSI21		IIC21

• 64-pin products

Unit	Channel	Used as simplified SPI (CSI)	Used as UART	Used as Simplified I ² C
0	0	CSI00	UART0	IIC00
	1	CSI01		IIC01
	2	CSI10	UART1	IIC10
	3	CSI11		IIC11
1	0	CSI20	UART2 (supporting LIN-bus)	IIC20
	1	CSI21		IIC21

• 80, 100, 128-pin products

Unit	Channel	Used as simplified SPI (CSI)	Used as UART	Used as Simplified I ² C
0	0	CSI00	UART0	IIC00
	1	CSI01		IIC01
	2	CSI10	UART1	IIC10
	3	CSI11		IIC11
1	0	CSI20	UART2 (supporting LIN-bus)	IIC20
	1	CSI21		IIC21
	2	CSI30	UART3	IIC30
	3	CSI31		IIC31

Select any function for each channel. Only the selected function is possible. If UART0 is selected for channels 0 and 1 of unit 0, for example, these channels cannot be used for CSI00 and CSI01. At this time, however, channel 2, 3, or other channels of the same unit can be used for a function other than UART0, such as CSI10, UART1, and IIC10.

Caution When using a serial array unit for UART, both the transmitter side (even-numbered channel) and the receiver side (odd-numbered channel) can only be used for UART.

UART performs the following four types of communication operations.

- UART transmission (See 12.6.1.)
- UART reception (See 12.6.2.)
- LIN transmission (UART2 only) (See 12.7.1.)
- LIN reception (UART2 only) (See 12.7.2.)

12.6.1 UART transmission

UART transmission is an operation to transmit data from the RL78 microcontroller to another device asynchronously (start-stop synchronization).

Of two channels used for UART, the even channel is used for UART transmission.

UART	UART0	UART1	UART2	UART3
Target channel	Channel 0 of SAU0	Channel 2 of SAU0	Channel 0 of SAU1	Channel 2 of SAU1
Pins used	TxD0	TxD1	TxD2	TxD3
Interrupt	INTST0	INTST1	INTST2	INTST3
	Transfer end interrupt (in single-transfer mode) or buffer empty interrupt (in continuous transfer mode) can be selected.			
Error detection flag	None			
Transfer data length	7, 8, or 9 bits ^{Note 1}			
Transfer rate ^{Note 2}	Max. $f_{MCK}/6$ [bps] (SDR _{mn} [15:9] = 2 or more), Min. $f_{CLK}/(2 \times 2^{15} \times 128)$ [bps]			
Data phase	Non-reverse output (default: high level) Reverse output (default: low level)			
Parity bit	The following selectable <ul style="list-style-type: none"> • No parity bit • Appending 0 parity • Appending even parity • Appending odd parity 			
Stop bit	The following selectable <ul style="list-style-type: none"> • Appending 1 bit • Appending 2 bits 			
Data direction	MSB or LSB first			

Notes 1. Only the following UARTs can be specified for the 9-bit data length.

- 20 to 64-pin products: UART0
- 80 to 128-pin products: UART0 and UART2

2. Use this operation within a range that satisfies the conditions above and the peripheral functions characteristics in the electrical specifications (see **CHAPTER 29 ELECTRICAL SPECIFICATIONS (T_A = -40 to +85°C)** and **CHAPTER 30 ELECTRICAL SPECIFICATIONS (G: INDUSTRIAL APPLICATIONS T_A = -40 to +105°C)**).

Remarks 1. f_{MCK} : Operation clock frequency of target channel

f_{CLK} : System clock frequency

2. m: Unit number (m = 0, 1), n: Channel number (n = 0, 2), mn = 00, 02, 10, 12

(1) Register setting

Figure 12-76. Example of Contents of Registers for UART Transmission of UART (UART0 to UART3) (1/2)

(a) Serial mode register mn (SMRmn)

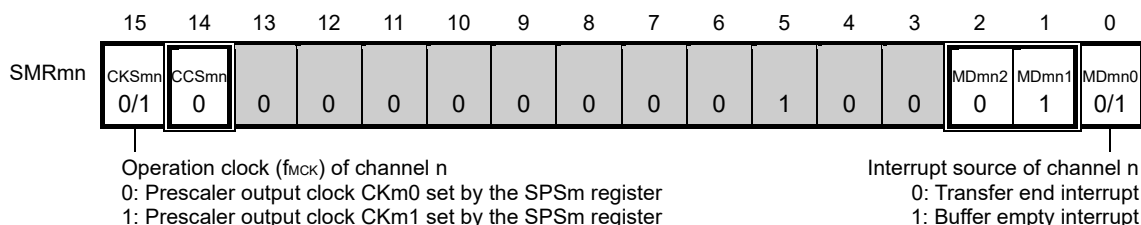

(b) Serial communication operation setting register mn (SCRmn)

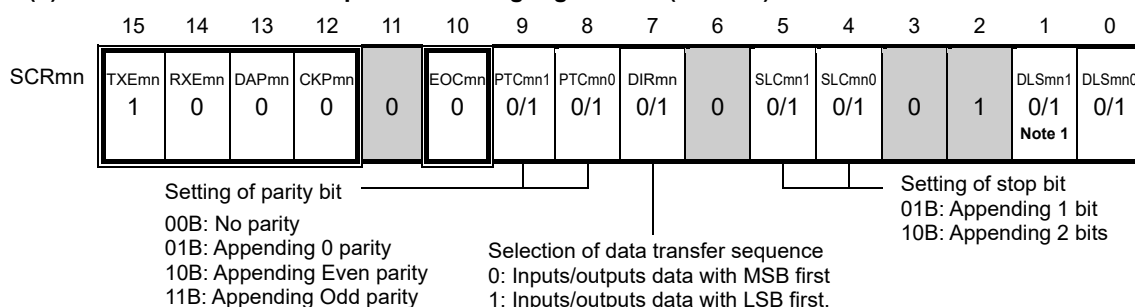

(c) Serial data register mn (SDRmn) (lower 8 bits: TXDq)

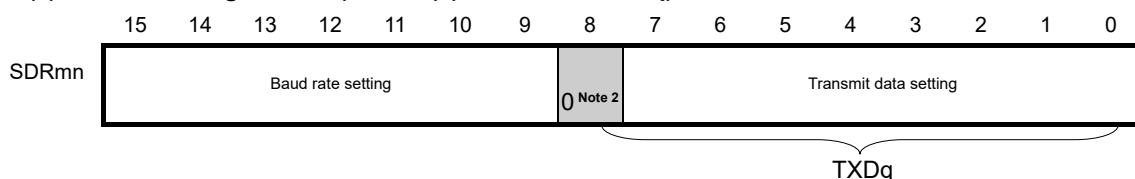

(d) Serial output level register m (SOLm) ... Sets only the bits of the target channel.

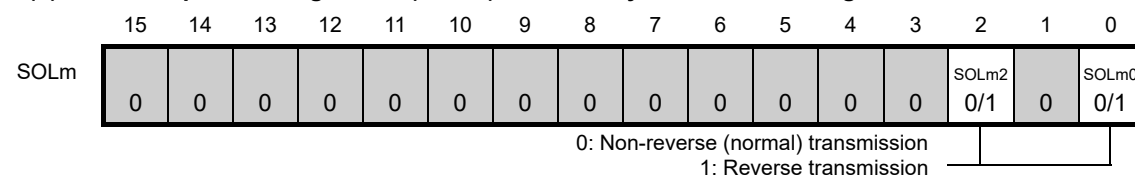

- Notes 1.** Only provided for the SCR00 register and the SCR10 register of an 80- to 128-pin product. This bit is fixed to 1 for the other registers.
- 2.** When UART0 performs 9-bit communication (by setting the DLS001 and DLS000 bits of the SCR00 register to 1), bits 0 to 8 of the SDR00 register are used as the transmission data specification area. Only the following UARTs can be specified for the 9-bit data length.
- 20 to 64-pin products: UART0
 - 80 to 128-pin products: UART0 and UART2

- Remarks 1.** m: Unit number (m = 0, 1), n: Channel number (n = 0, 2), q: UART number (q = 0 to 3), mn = 00, 02, 10, 12
- 2.** □: Setting is fixed in the UART transmission mode, ■: Setting disabled (set to the initial value)
 0/1: Set to 0 or 1 depending on the usage of the user

Figure 12-76. Example of Contents of Registers for UART Transmission of UART (UART0 to UART3) (2/2)

(e) Serial output register m (SOm) ... Sets only the bits of the target channel.



(f) Serial output enable register m (SOEm) ... Sets only the bits of the target channel to 1.

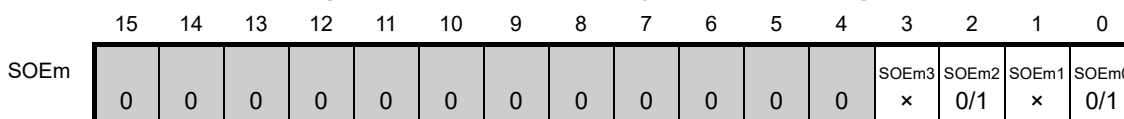

(g) Serial channel start register m (SSm) ... Sets only the bits of the target channel to 1.

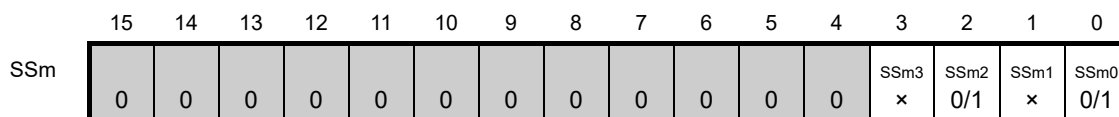

Note Before transmission is started, be sure to set to 1 when the SOLmn bit of the target channel is set to 0, and set to 0 when the SOLmn bit of the target channel is set to 1. The value varies depending on the communication data during communication operation.

- Remarks**
1. m: Unit number (m = 0, 1), n: Channel number (n = 0, 2),
mn = 00, 02, 10, 12
 2. : Setting is fixed in the UART transmission mode, : Setting disabled (set to the initial value)
0/1: Set to 0 or 1 depending on the usage of the user

(2) Operation procedure

Figure 12-77. Initial Setting Procedure for UART Transmission

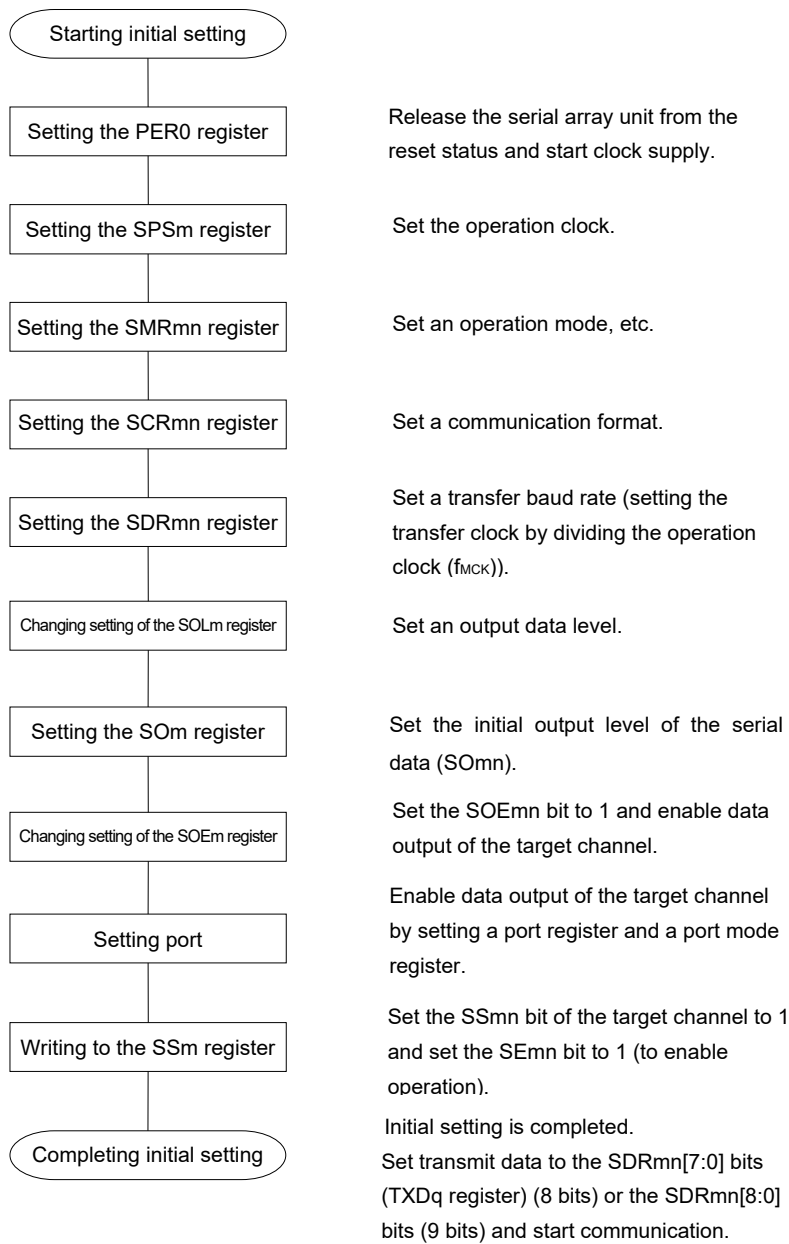

Figure 12-78. Procedure for Stopping UART Transmission

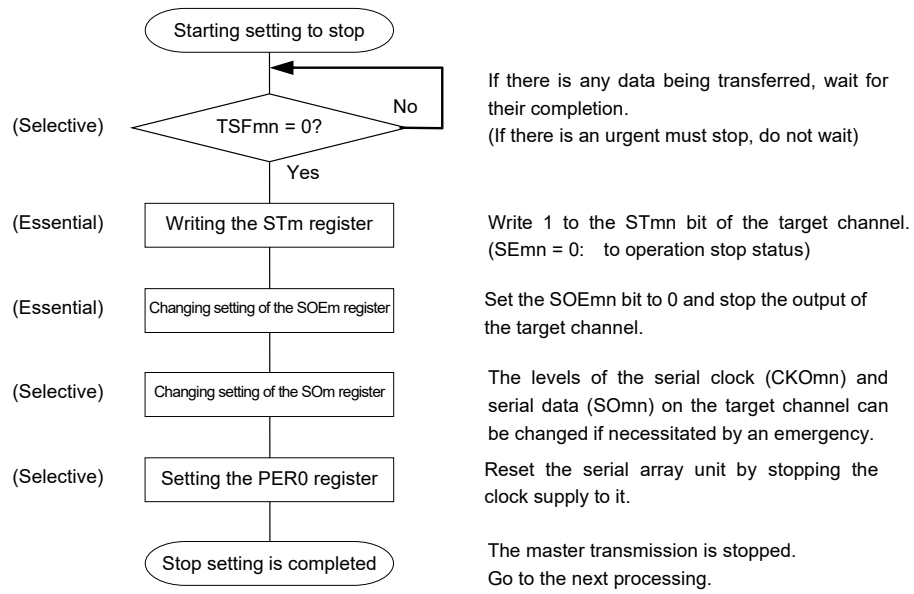
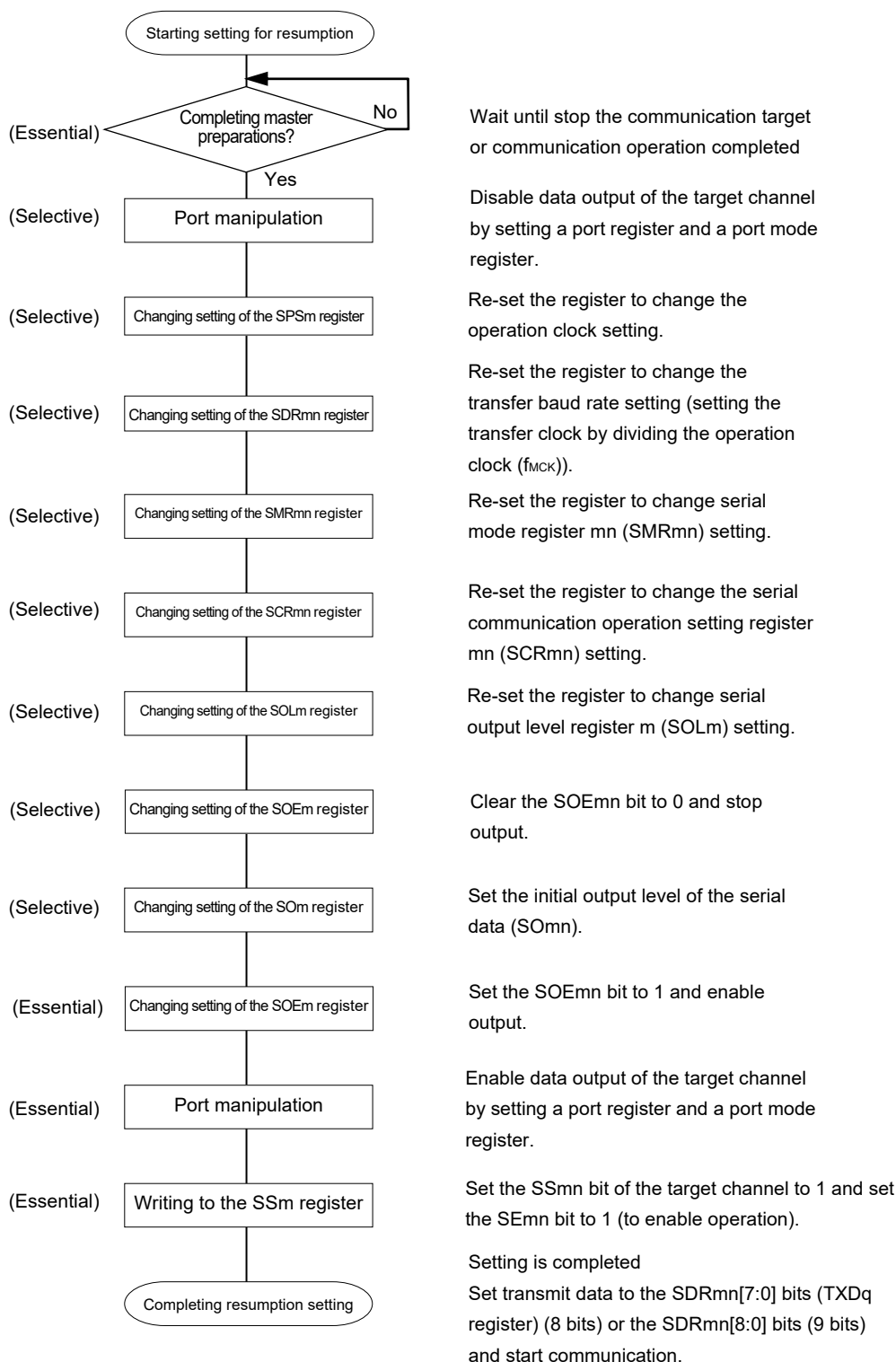

Figure 12-79. Procedure for Resuming UART Transmission



Remark If PER0 is rewritten while stopping the master transmission and the clock supply is stopped, wait until the transmission target stops or transmission finishes, and then perform initialization instead of restarting the transmission.

(3) Processing flow (in single-transmission mode)

Figure 12-80. Timing Chart of UART Transmission (in Single-Transmission Mode)

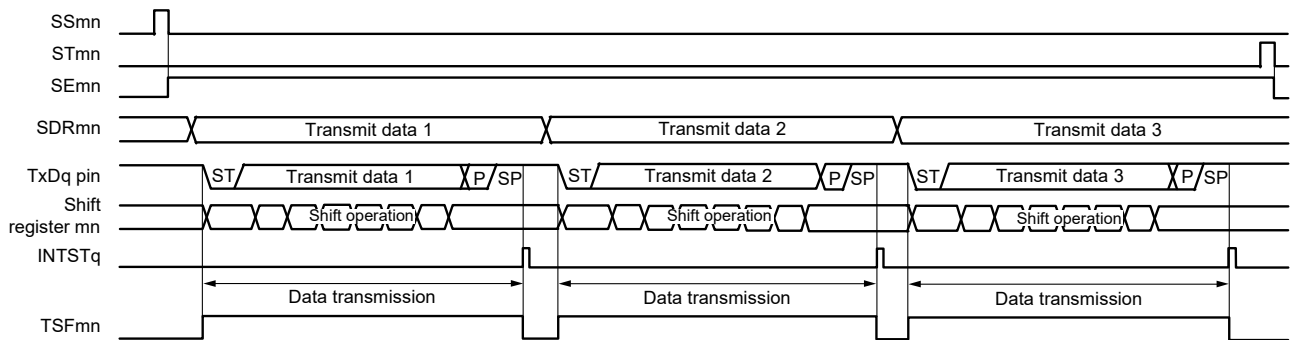

Remark m: Unit number (m = 0, 1), n: Channel number (n = 0, 2), q: UART number (q = 0 to 3)
 mn = 00, 02, 10, 12

Figure 12-81. Flowchart of UART Transmission (in Single-Transmission Mode)

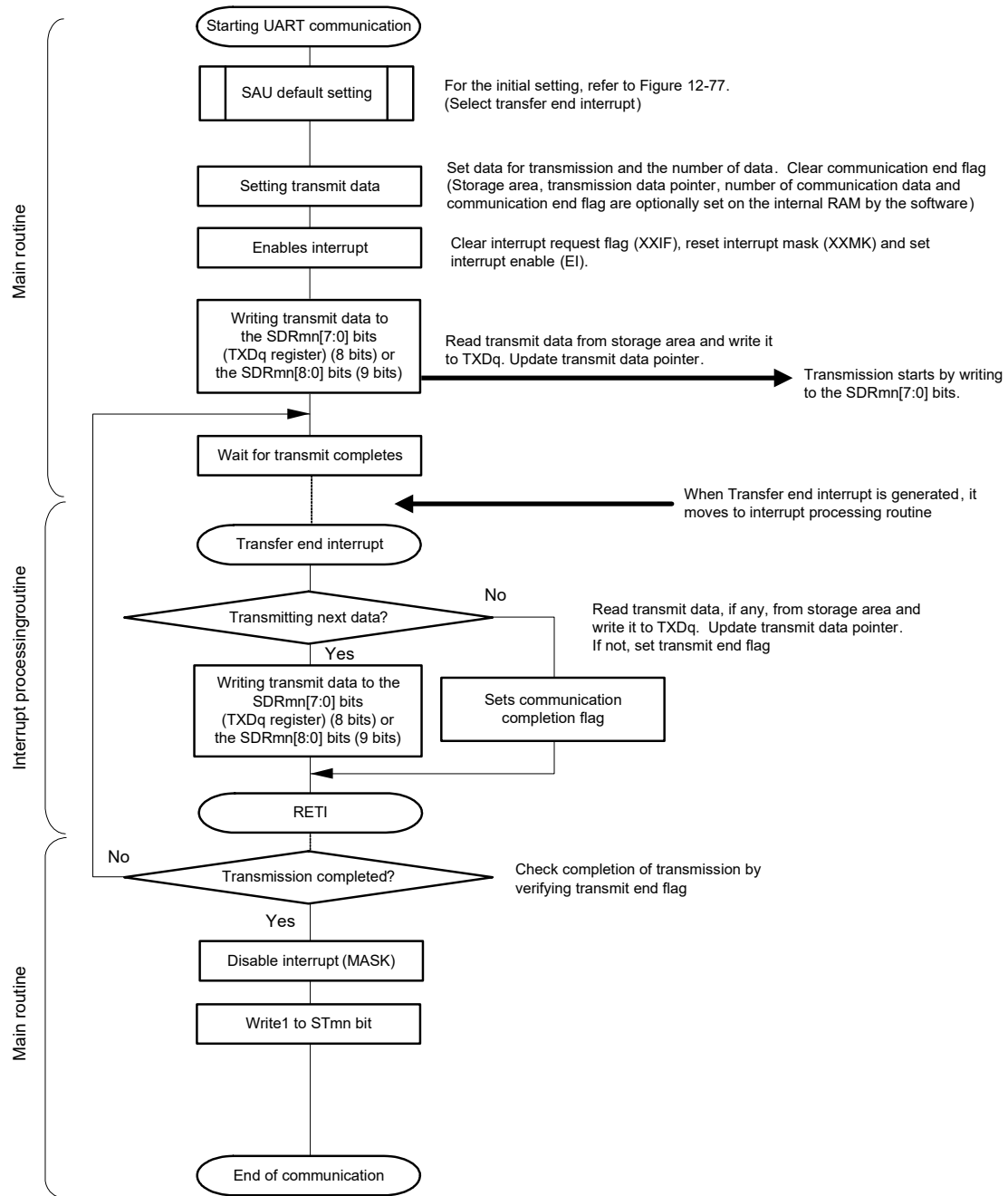

(4) Processing flow (in continuous transmission mode)

Figure 12-82. Timing Chart of UART Transmission (in Continuous Transmission Mode)

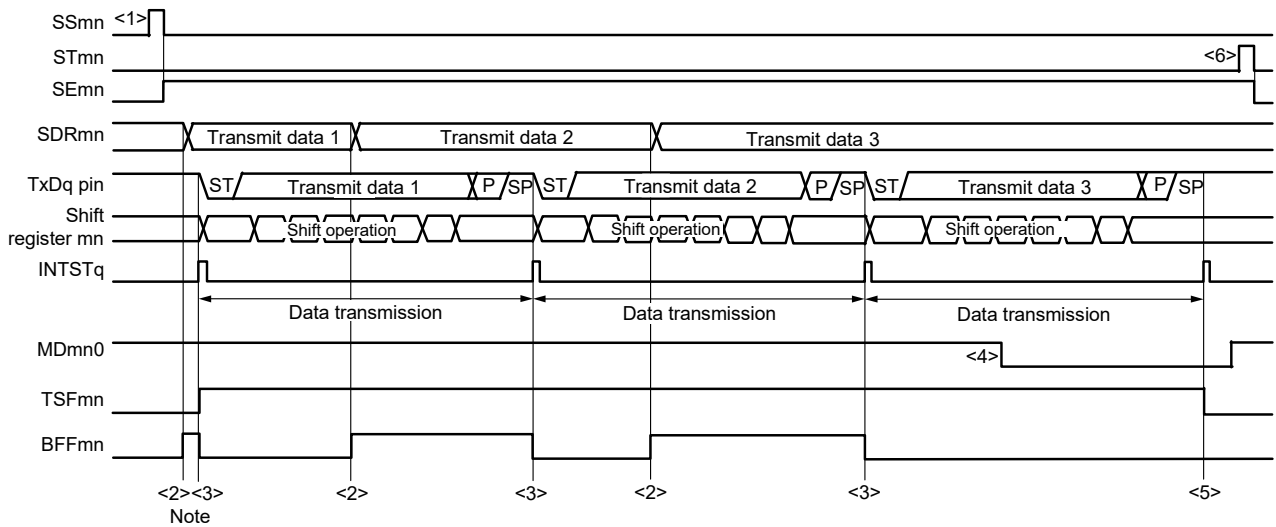

Note If transmit data is written to the SDRmn register while the BFFmn bit of serial status register mn (SSRmn) is 1 (valid data is stored in serial data register mn (SDRmn)), the transmit data is overwritten.

Caution The MDmn0 bit of serial mode register mn (SSRmn) can be rewritten even during operation. However, rewrite it before transfer of the last bit is started, so that it will be rewritten before the transfer end interrupt of the last transmit data.

Remark m: Unit number (m = 0, 1), n: Channel number (n = 0, 2), q: UART number (q = 0 to 3)
mn = 00, 02, 10, 12

Figure 12-83. Flowchart of UART Transmission (in Continuous Transmission Mode)

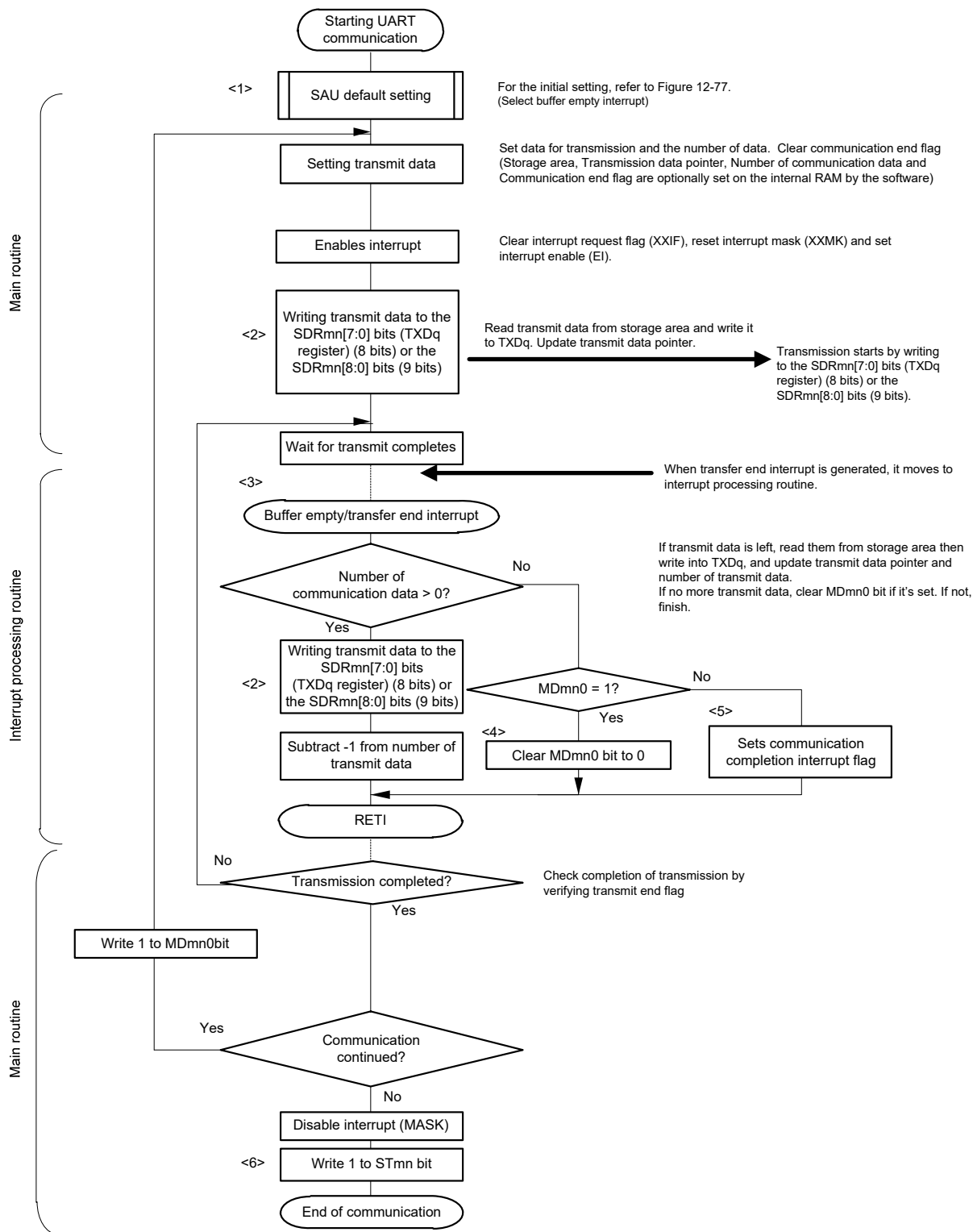

Remark <1> to <6> in the figure correspond to <1> to <6> in Figure 12-82 Timing Chart of UART Transmission (in Continuous Transmission Mode).

12.6.2 UART reception

UART reception is an operation wherein the RL78 microcontroller asynchronously receives data from another device (start-stop synchronization).

For UART reception, the odd-number channel of the two channels used for UART is used. The SMR register of both the odd- and even-numbered channels must be set.

UART	UART0	UART1	UART2	UART3
Target channel	Channel 1 of SAU0	Channel 3 of SAU0	Channel 1 of SAU1	Channel 3 of SAU1
Pins used	RxD0	RxD1	RxD2	RxD3
Interrupt	INTSR0	INTSR1	INTSR2	INTSR3
	Transfer end interrupt only (Setting the buffer empty interrupt is prohibited.)			
Error interrupt	INTSRE0	INTSRE1	INTSRE2	INTSRE3
Error detection flag	<ul style="list-style-type: none"> • Framing error detection flag (FEF_{mn}) • Parity error detection flag (PEF_{mn}) • Overrun error detection flag (OVF_{mn}) 			
Transfer data length	7, 8 or 9 bits ^{Note 1}			
Transfer rate ^{Note 2}	Max. $f_{MCK}/6$ [bps] (SDR _{mn} [15:9] = 2 or more), Min. $f_{CLK}/(2 \times 2^{15} \times 128)$ [bps]			
Data phase	Non-reverse output (default: high level) Reverse output (default: low level)			
Parity bit	The following selectable <ul style="list-style-type: none"> • No parity bit (no parity check) • No parity judgment (0 parity) • Even parity check • Odd parity check 			
Stop bit	Appending 1 bit			
Data direction	MSB or LSB first			

Notes 1. Only the following UARTs can be specified for the 9-bit data length.

- 20 to 64-pin products: UART0 only
- 80 to 128-pin products: UART0 and UART2 only

2. Use this operation within a range that satisfies the conditions above and the peripheral functions characteristics in the electrical specifications (see **CHAPTER 29 ELECTRICAL SPECIFICATIONS (T_A = -40 to +85°C)** and **CHAPTER 30 ELECTRICAL SPECIFICATIONS (G: INDUSTRIAL APPLICATIONS T_A = -40 to +105°C)**).

Remarks 1. f_{MCK} : Operation clock frequency of target channel

f_{CLK} : System clock frequency

2. m: Unit number (m = 0, 1), n: Channel number (n = 1, 3), mn = 01, 03, 11, 13

(1) Register setting

Figure 12-84. Example of Contents of Registers for UART Reception of UART (UART0 to UART3) (1/2)

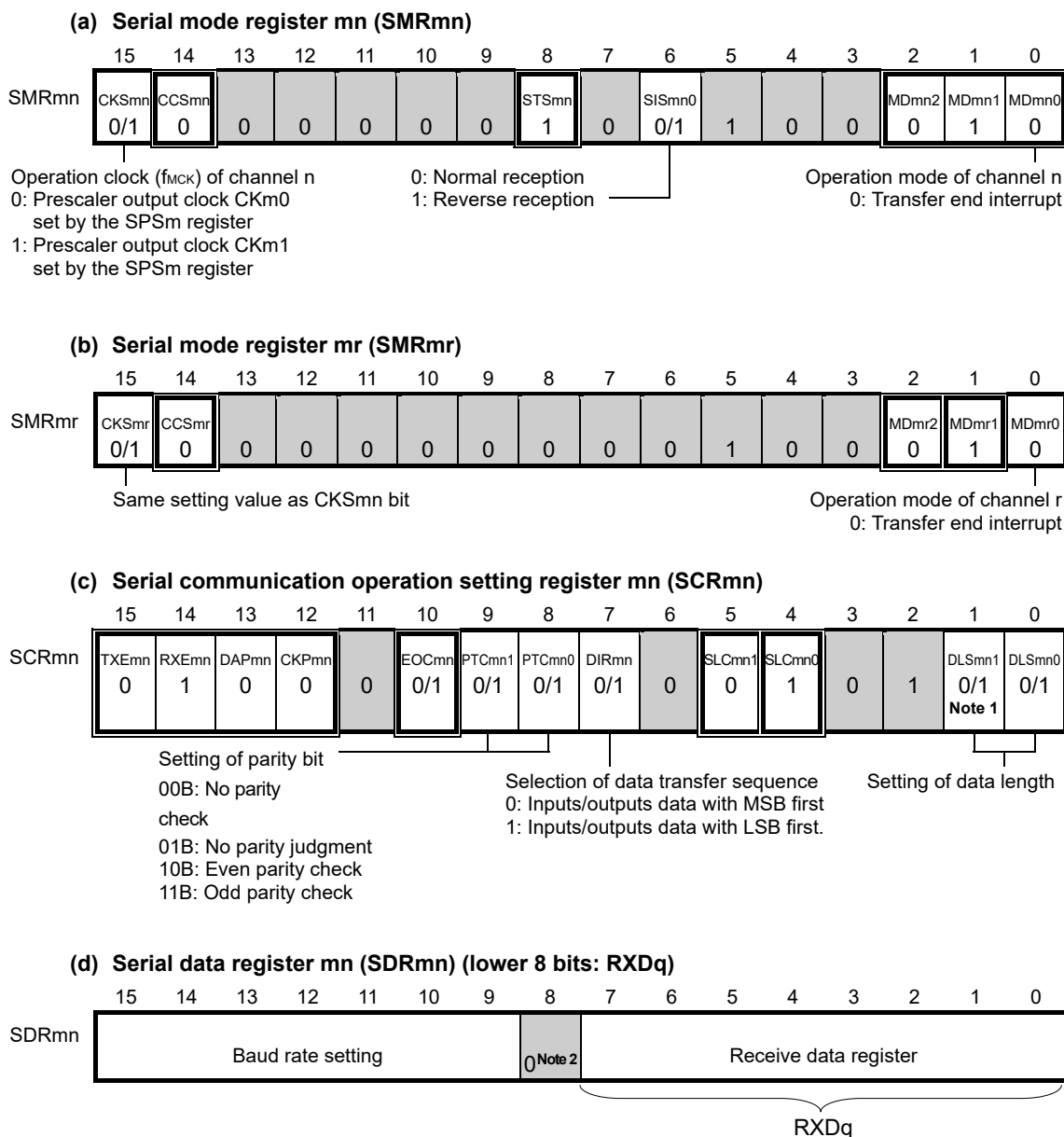

- Notes**
- Only provided for the SCR01 register and the SCR11 register of an 80- to 128-pin product. This bit is fixed to 1 for the other registers.
 - When UART performs 9-bit communication, bits 0 to 8 of the SDRm1 register are used as the reception data specification area. Only the following UARTs can be specified for the 8-bit data length.
 - 20 to 64-pin products: UART0
 - 80 to 128-pin products: UART0 and UART2

Caution For the UART reception, be sure to set the SMRmr register of channel r to UART transmission mode that is to be paired with channel n.

- Remarks**
- m: Unit number (m = 0, 1), n: Channel number (n = 1, 3), mn = 01, 03, 11, 13
 r: Channel number (r = n - 1), q: UART number (q = 0 to 3)
 - : Setting is fixed in the UART reception mode, ■: Setting disabled (set to the initial value)
 0/1: Set to 0 or 1 depending on the usage of the user

Figure 12-84. Example of Contents of Registers for UART Reception of UART (UART0 to UART3) (2/2)

(e) Serial output register m (SOM) ... The register that not used in this mode.

	15	14	13	12	11	10	9	8	7	6	5	4	3	2	1	0
SOM	0	0	0	0	CKOm3	CKOm2	CKOm1	CKOm0	0	0	0	0	SOM3	SOM2	SOM1	SOM0
					x	x	x	x					x	x	x	x

(f) Serial output enable register m (SOEm) ...The register that not used in this mode.

	15	14	13	12	11	10	9	8	7	6	5	4	3	2	1	0
SOEm	0	0	0	0	0	0	0	0	0	0	0	0	SOEm3	SOEm2	SOEm1	SOEm0
													x	x	x	x

(g) Serial channel start register m (SSm) ... Sets only the bits of the target channel is 1.

	15	14	13	12	11	10	9	8	7	6	5	4	3	2	1	0
SSm	0	0	0	0	0	0	0	0	0	0	0	0	SSm3	SSm2	SSm1	SSm0
													0/1	x	0/1	x

Remarks 1. m: Unit number (m = 0, 1)

2. : Setting disabled (set to the initial value)

x: Bit that cannot be used in this mode (set to the initial value when not used in any mode)

0/1: Set to 0 or 1 depending on the usage of the user

(2) Operation procedure

Figure 12-85. Initial Setting Procedure for UART Reception

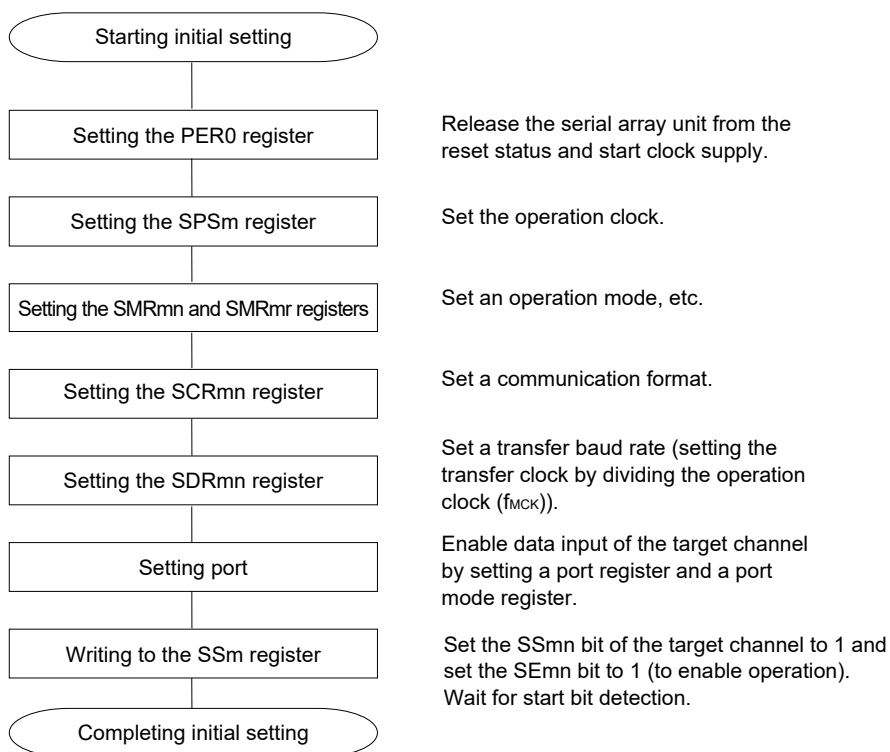

Caution Set the RXEmn bit of SCRmn register to 1, and then be sure to set SSmn to 1 after 4 or more f_{MCK} clocks have elapsed.

Figure 12-86. Procedure for Stopping UART Reception

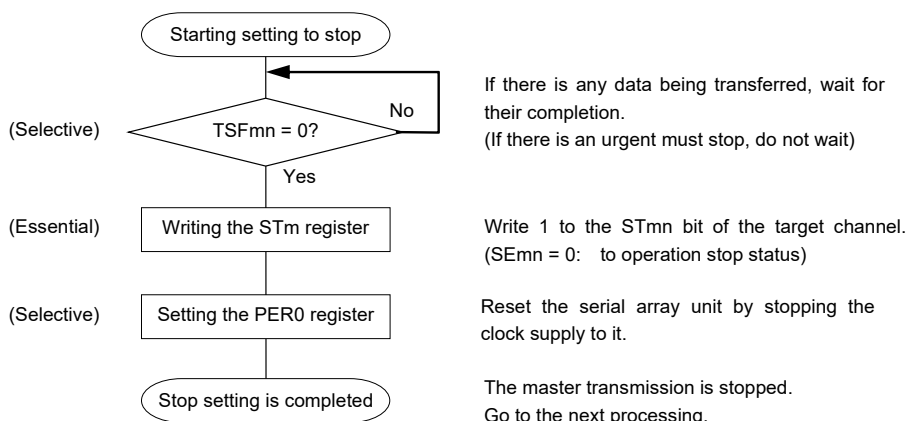
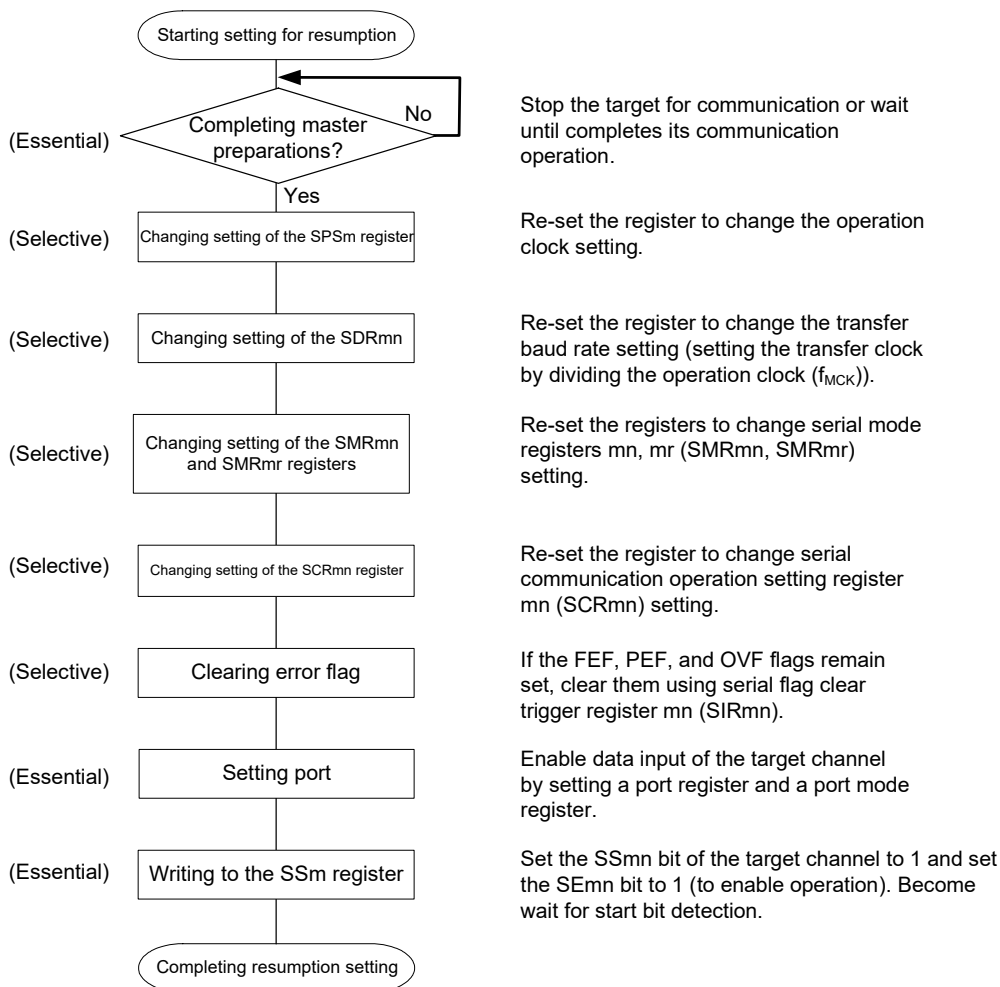

Figure 12-87. Procedure for Resuming UART Reception



Caution After is set RXEmn bit to 1 of SCRmn register, set the SSmn = 1 from an interval of at least four clocks of f_{MCK}.

Remark If PER0 is rewritten while stopping the master transmission and the clock supply is stopped, wait until the transmission target (slave) stops or transmission finishes, and then perform initialization instead of restarting the transmission.

(3) Processing flow

Figure 12-88. Timing Chart of UART Reception

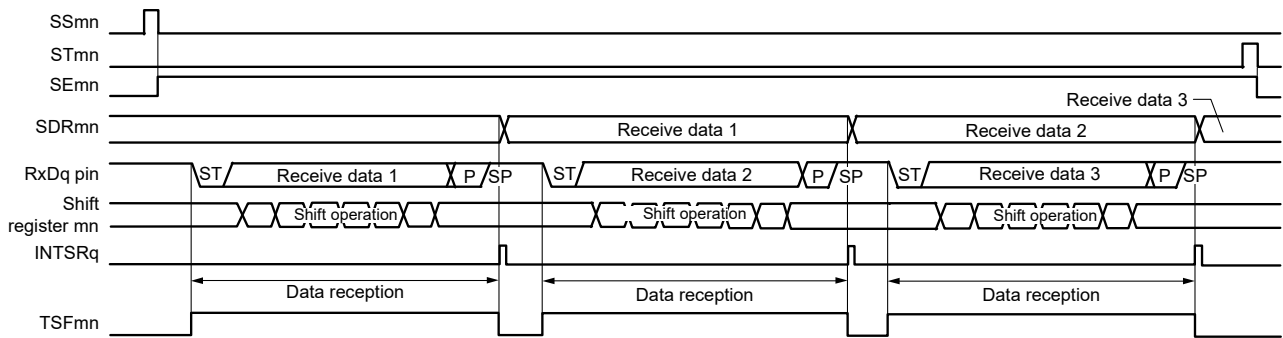

Remark m: Unit number (m = 0, 1), n: Channel number (n = 1, 3), mn = 01, 03, 11, 13
 r: Channel number (r = n - 1), q: UART number (q = 0 to 3)

Figure 12-89. Flowchart of UART Reception

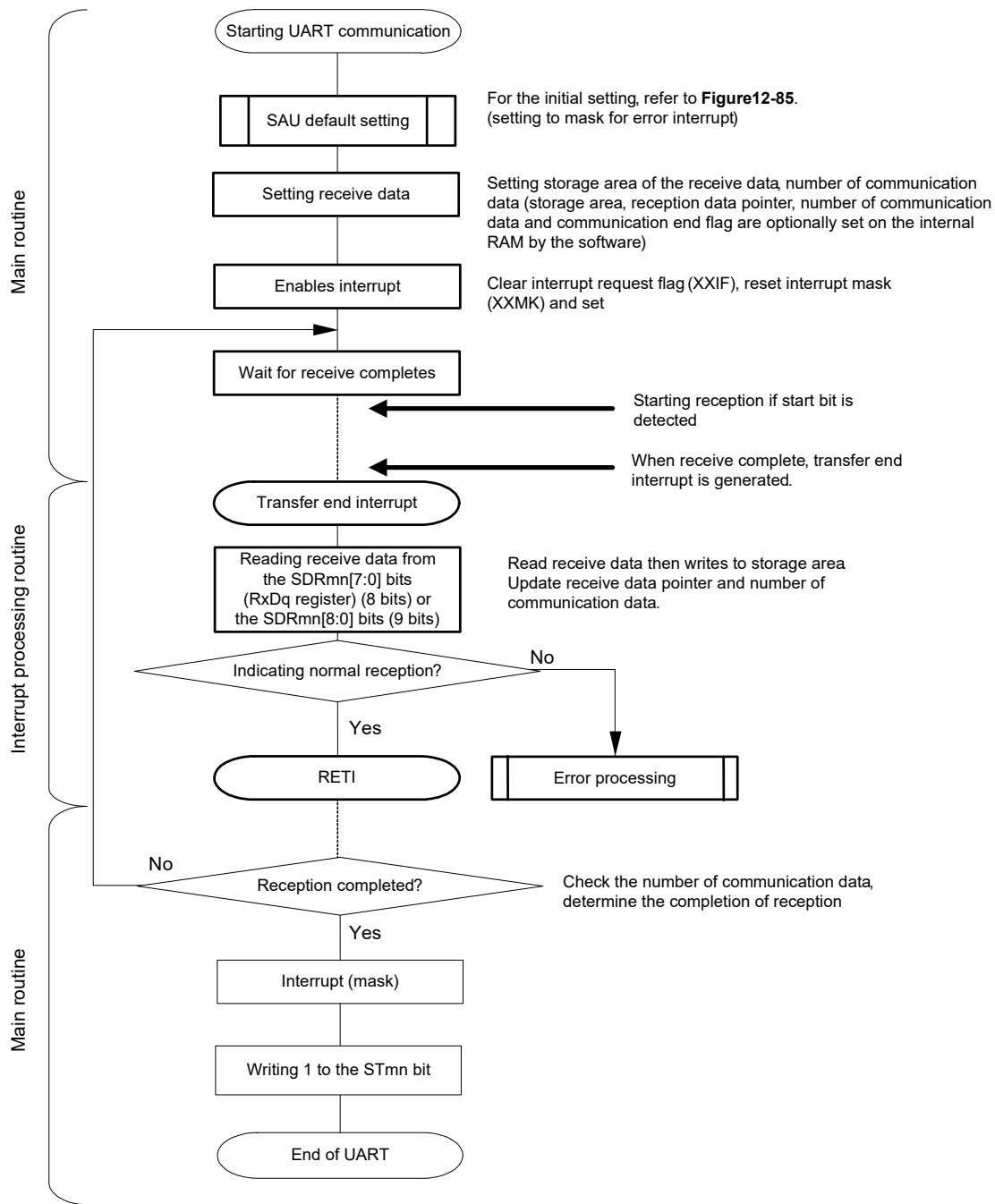

12.6.3 SNOOZE mode function

The SNOOZE mode makes the UART perform reception operations upon RxDq pin input detection while in the STOP mode. Normally the UART stops communication in the STOP mode. However, using the SNOOZE mode enables the UART to perform reception operations without CPU operation.

Only the following channels can be set to the SNOOZE mode.

- 20 to 64-pin products: UART0
- 80 to 128-pin products: UART0 and UART2

When using UARTq in the SNOOZE mode, make the following settings before entering the STOP mode. (See **Figure 12-92 Flowchart of SNOOZE Mode Operation (EOCm1 = 0, SSECm = 0/1 or EOCm1 = 1, SSECm = 0)** and **Figure 12-94 Flowchart of SNOOZE Mode Operation (EOCm1 = 1, SSECm = 1)**.)

- In the SNOOZE mode, the baud rate setting for UART reception needs to be changed to a value different from that in normal operation. Set the SPSm register and bits 15 to 9 of the SDRm register with reference to Table 12-3.
- Set the EOCmn and SSECmn bits. This is for enabling or stopping generation of an error interrupt (INTSRE0) when a communication error occurs.
- When using the SNOOZE mode function, set the SWCm bit of serial standby control register m (SSCm) to 1 just before switching to the STOP mode. After the initial setting has completed, set the SSm1 bit of serial channel start register m (SSm) to 1.
- A UARTq starts reception in SNOOZE mode on detecting input of the start bit on the RxDq pin following a transition of the CPU to the STOP mode.

Cautions 1. The SNOOZE mode can only be used when the high-speed on-chip oscillator clock (f_{IH}) is selected for f_{CLK} .

2. The transfer rate in the SNOOZE mode is only 4800 bps.

3. When SWCm = 1, UARTq can be used only when the reception operation is started in the STOP mode. When used simultaneously with another SNOOZE mode function or interrupt, if the reception operation is started in a state other than the STOP mode, such as those given below, data may not be received correctly and a framing error or parity error may be generated.

- When after the SWCm bit has been set to 1, the reception operation is started before the STOP mode is entered
- When the reception operation is started while another function is in the SNOOZE mode
- When after returning from the STOP mode to normal operation due to an interrupt or other cause, the reception operation is started before the SWCm bit is returned to 0

4. If a parity error, framing error, or overrun error occurs while the SSECm bit is set to 1, the PEFmn, FEFmn, or OVFMn flag is not set and an error interrupt (INTSREq) is not generated. Therefore, when the setting of SSECm = 1 is made, clear the PEFmn, FEFmn, or OVFMn flag before setting the SWC0 bit to 1 and read the value in bits 7 to 0 (RxDq register) of the SDRm1 register.

5. The CPU shifts from the STOP mode to the SNOOZE mode on detecting the valid edge of the RxDq signal. Note, however, that transfer through the UART channel may not start and the CPU may remain in the SNOOZE mode if an input pulse on the RxDq pin is too short to be detected as a start bit.

In such cases, data may not be received correctly, and this may lead to a framing error or parity error in the next UART transfer.

Table 12-3. Baud Rate Setting for UART Reception in SNOOZE Mode

High-speed On-chip Oscillator (f_{IH})	Baud Rate for UART Reception in SNOOZE Mode			
	Baud Rate of 4800 bps			
	Operation Clock (f_{MCK})	SDRmn[15:9]	Maximum Permissible Value	Minimum Permissible Value
32 MHz \pm 1.0% ^{Note}	$f_{CLK}/2^5$	105	2.27%	-1.53%
24 MHz \pm 1.0% ^{Note}	$f_{CLK}/2^5$	79	1.60%	-2.18%
16 MHz \pm 1.0% ^{Note}	$f_{CLK}/2^4$	105	2.27%	-1.53%
12 MHz \pm 1.0% ^{Note}	$f_{CLK}/2^4$	79	1.60%	-2.19%
8 MHz \pm 1.0% ^{Note}	$f_{CLK}/2^3$	105	2.27%	-1.53%
6 MHz \pm 1.0% ^{Note}	$f_{CLK}/2^3$	79	1.60%	-2.19%
4 MHz \pm 1.0% ^{Note}	$f_{CLK}/2^2$	105	2.27%	-1.53%
3 MHz \pm 1.0% ^{Note}	$f_{CLK}/2^2$	79	1.60%	-2.19%
2 MHz \pm 1.0% ^{Note}	$f_{CLK}/2$	105	2.27%	-1.54%
1 MHz \pm 1.0% ^{Note}	f_{CLK}	105	2.27%	-1.57%

Note When the accuracy of the clock frequency of the high-speed on-chip oscillator is $\pm 1.5\%$ or $\pm 2.0\%$, the permissible range becomes smaller as shown below.

- In the case of $f_{IH} \pm 1.5\%$, perform (Maximum permissible value - 0.5%) and (Minimum permissible value + 0.5%) to the values in the above table.
- In the case of $f_{IH} \pm 2.0\%$, perform (Maximum permissible value - 1.0%) and (Minimum permissible value + 1.0%) to the values in the above table.

Remark The maximum permissible value and minimum permissible value are permissible values for the baud rate in UART reception. The baud rate on the transmitting side should be set to fall inside this range.

(1) SNOOZE mode operation (EOCm1 = 0, SSECm = 0/1)

Because of the setting of EOCm1 = 0, even though a communication error occurs, an error interrupt (INTSREq) is not generated, regardless of the setting of the SSECm bit. A transfer end interrupt (INTSRq) will be generated.

Figure 12-90. Timing Chart of SNOOZE Mode Operation (EOCm1 = 0, SSECm = 0/1)

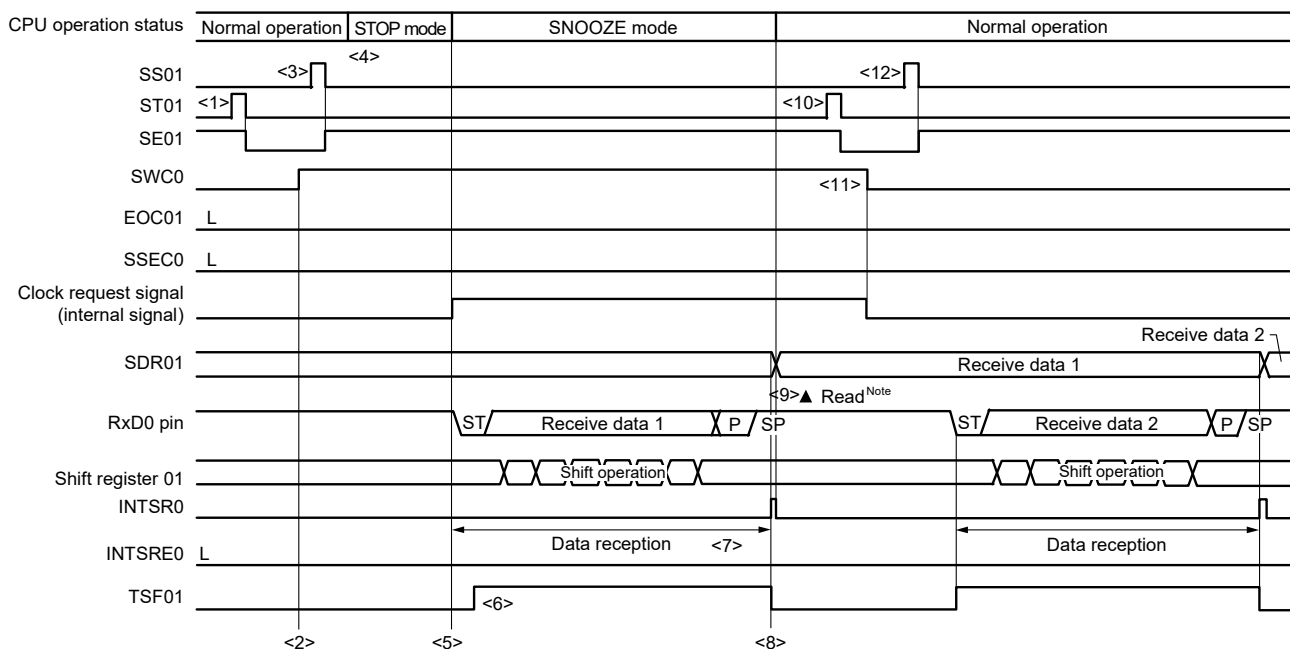

Note Read the received data when SWCm = 1.

Caution Before switching to the SNOOZE mode or after reception operation in the SNOOZE mode finishes, set the STm1 bit to 1 (clear the SEM1 bit and stop the operation). After the receive operation completes, also clear the SWCm bit to 0 (SNOOZE mode release).

Remarks 1. <1> to <12> in the figure correspond to <1> to <12> in Figure 12-92 Flowchart of SNOOZE Mode Operation (EOCm1 = 0, SSECm = 0/1 or EOCm1 = 1, SSECm = 0).

- 2. 20 to 64-pin products: m = 0; q = 0
- 80 to 128-pin products: m = 0, 1; q = 0, 2

(2) SNOOZE mode operation (EOCm1 = 1, SSECm = 0: Error interrupt (INTSREq) generation is enabled)

Because EOCm1 = 1 and SSECm = 0, an error interrupt (INTSREq) is generated when a communication error occurs.

Figure 12-91. Timing Chart of SNOOZE Mode Operation (EOCm1 = 1, SSECm = 0)

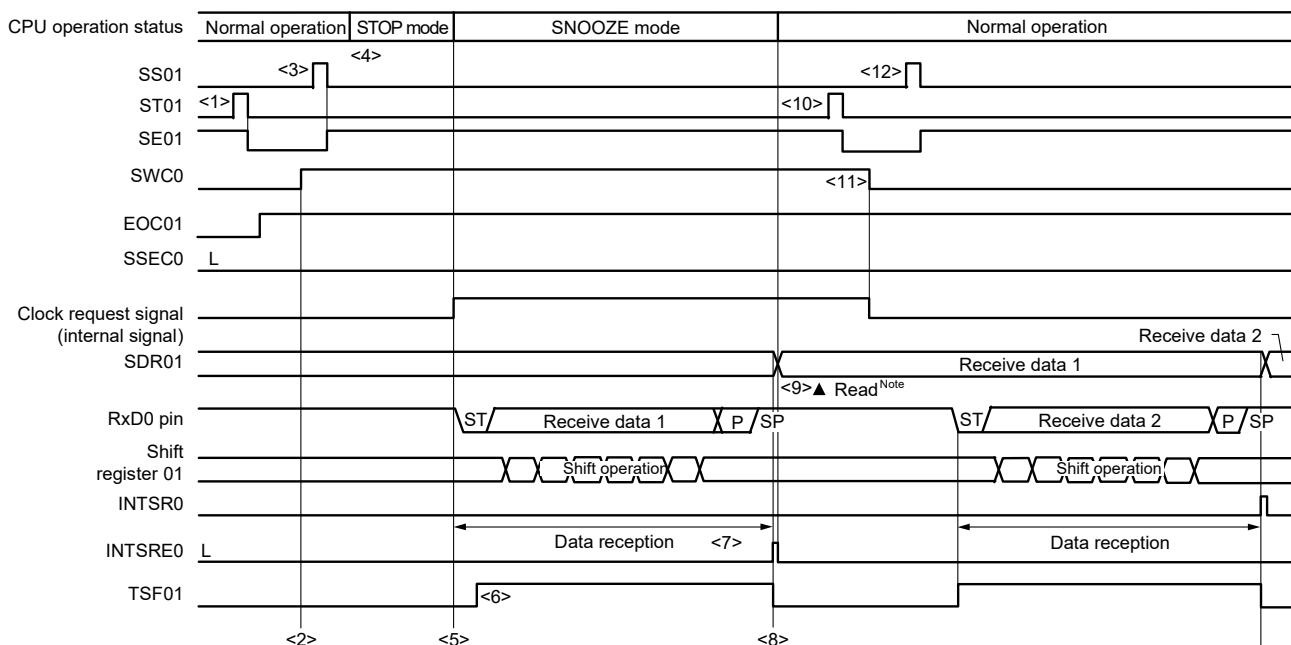

Note Read the received data when SWCm = 1.

Caution Before switching to the SNOOZE mode or after reception operation in the SNOOZE mode finishes, set the STm1 bit to 1 (clear the SEM1 bit and stop the operation).
After the receive operation completes, also clear the SWCm bit to 0 (SNOOZE mode release).

- Remarks**
1. <1> to <12> in the figure correspond to <1> to <12> in Figure 12-92 Flowchart of SNOOZE Mode Operation (EOCm1 = 0, SSECm = 0/1 or EOCm1 = 1, SSECm = 0).
 2. 20 to 64-pin products: m = 0; q = 0
80 to 128-pin products: m = 0, 1; q = 0, 2

Figure 12-92. Flowchart of SNOOZE Mode Operation (EOCm1 = 0, SSECm = 0/1 or EOCm1 = 1, SSECm = 0)

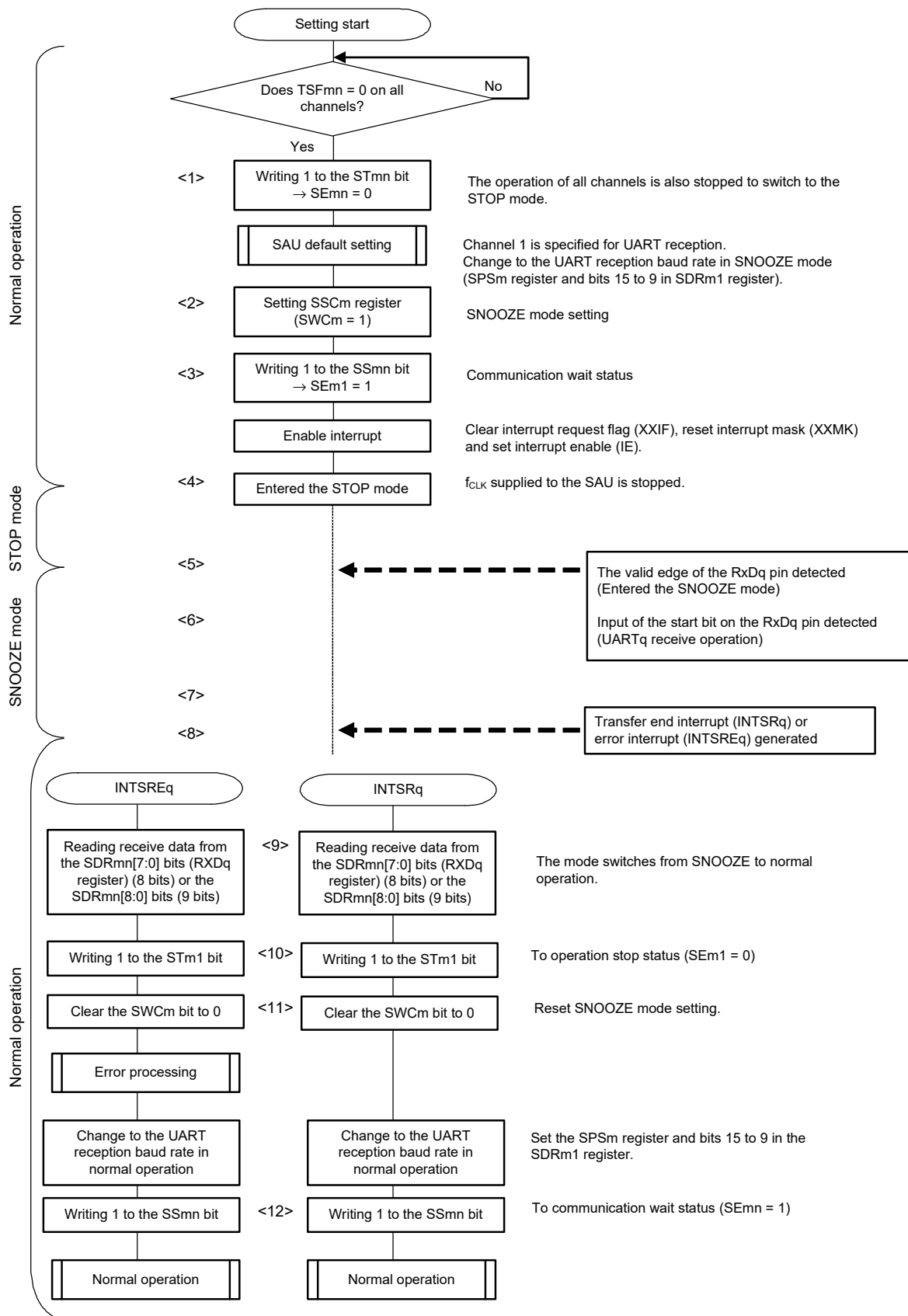

(Remarks are listed on the next page.)

Remarks 1. <1> to <12> in the figure correspond to <1> to <12> in **Figure 12-90 Timing Chart of SNOOZE Mode Operation (EOCm1 = 0, SSECm = 0/1)** and **Figure 12-91 Timing Chart of SNOOZE Mode Operation (EOCm1 = 1, SSECm = 0)**.

- 2. 20 to 64-pin products: m = 0; q = 0; n = 0 to 3
- 80 to 128-pin products: m = 0, 1; q = 0, 2; n = 0 to 3

(3) SNOOZE mode operation (EOCm1 = 1, SSECm = 1: Error interrupt (INTSREq) generation is stopped)

Because EOCm1 = 1 and SSECm = 1, an error interrupt (INTSREq) is not generated when a communication error occurs.

Figure 12-93. Timing Chart of SNOOZE Mode Operation (EOCm1 = 1, SSECm = 1)

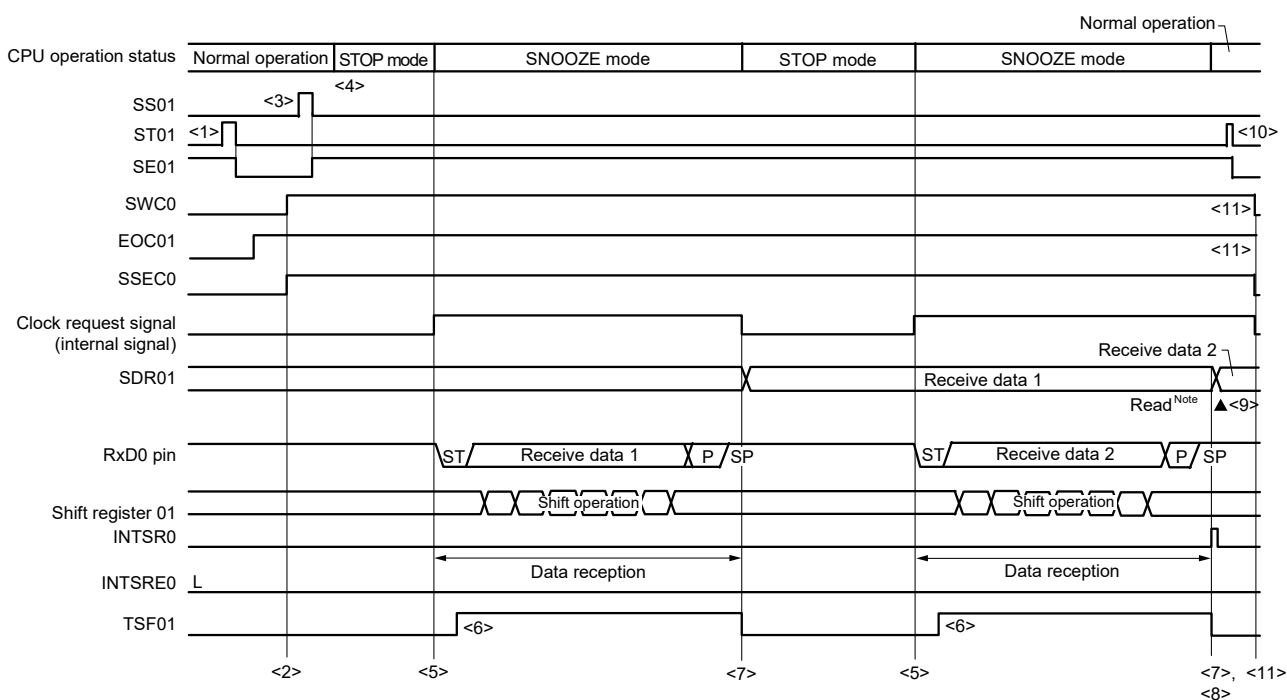

Note Read the received data when SWCm = 1.

- Cautions 1.** Before switching to the SNOOZE mode or after reception operation in the SNOOZE mode finishes, set the STm1 bit to 1 (clear the SEM1 bit and stop the operation). After the receive operation completes, also clear the SWCm bit to 0 (SNOOZE mode release).
2. If a parity error, framing error, or overrun error occurs while the SSECm bit is set to 1, the PEFm1, FEFm1, or OVFM1 flag is not set and an error interrupt (INTSREq) is not generated. Therefore, when the setting of SSECm = 1 is made, clear the PEFm1, FEFm1, or OVFM1 flag before setting the SWCm bit to 1 and read the value in SDRm1[7:0] (RxDq register) (8 bits) or SDRm1[8:0] (9 bits).

Remarks 1. <1> to <11> in the figure correspond to <1> to <11> in **Figure 12-94 Flowchart of SNOOZE Mode Operation (EOCm1 = 1, SSECm = 1)**.

- 2. 20 to 64-pin products: m = 0; q = 0
- 80 to 128-pin products: m = 0, 1; q = 0, 2

Figure 12-94. Flowchart of SNOOZE Mode Operation (EOCm1 = 1, SSECm = 1)

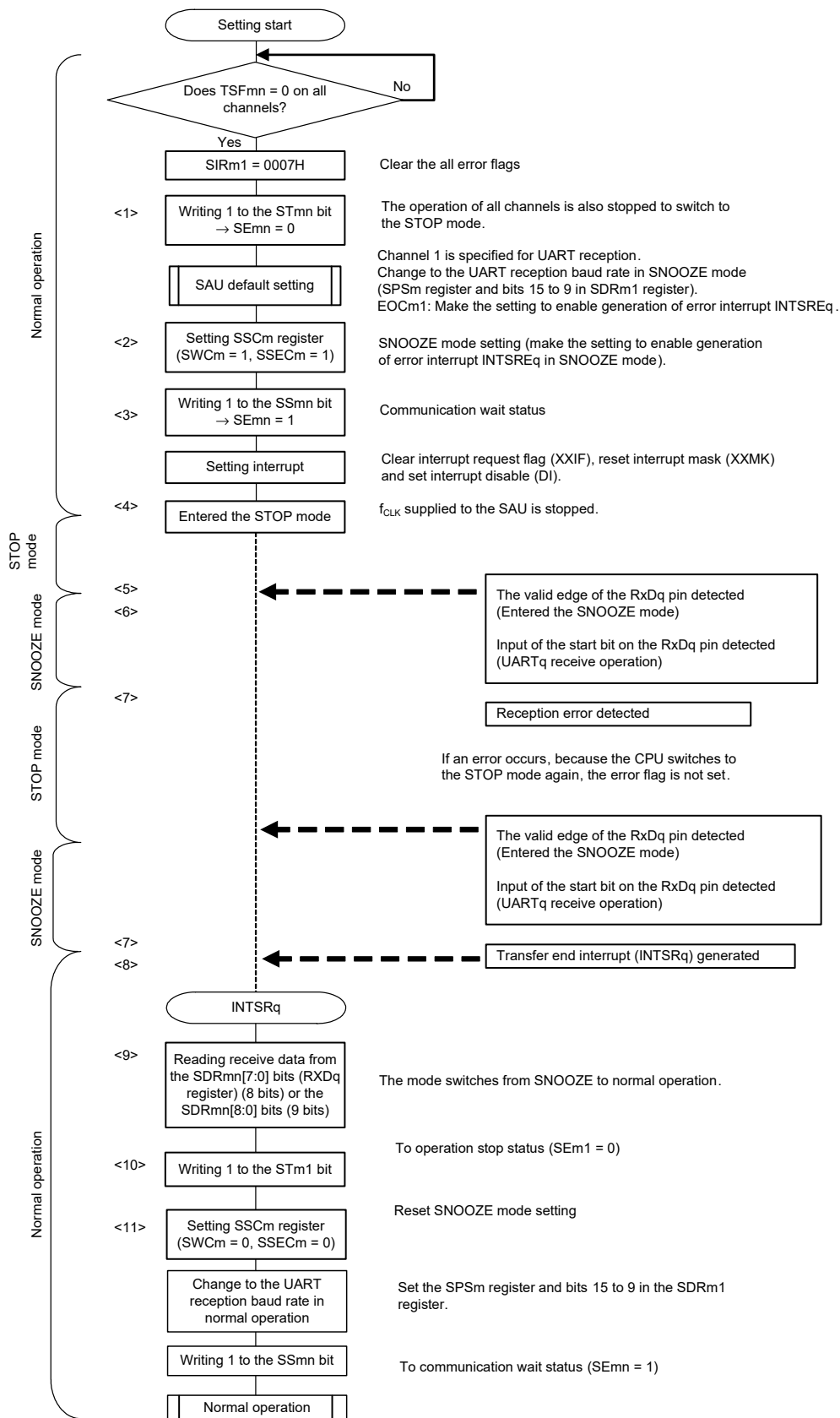

(Caution and Remarks are listed on the next page.)

Caution If a parity error, framing error, or overrun error occurs while the SSECm bit is set to 1, the PEFm1, FEFm1, or OVFM1 flag is not set and an error interrupt (INTSREq) is not generated. Therefore, when the setting of SSECm = 1 is made, clear the PEFm1, FEFm1, or OVFM1 flag before setting the SWCm bit to 1 and read the value in SDRm1[7:0] (RxDq register) (8 bits) or SDRm1[8:0] (9 bits).

Remarks 1. <1> to <11> in the figure correspond to <1> to <11> in **Figure 12-93 Timing Chart of SNOOZE Mode Operation (EOCm1 = 1, SSECm = 1).**

2. 20 to 64-pin products: m = 0; q = 0; n = 0 to 3
- 80 to 128-pin products: m = 0, 1; q = 0, 2; n = 0 to 3

12.6.4 Calculating baud rate

(1) Baud rate calculation expression

The baud rate for UART (UART0 to UART3) communication can be calculated by the following expressions.

$$\text{(Baud rate)} = \{\text{Operation clock (f}_{\text{MCK}}\text{) frequency of target channel}\} \div (\text{SDRmn}[15:9] + 1) \div 2 \text{ [bps]}$$

Caution Setting serial data register mn (SDRmn) SDRmn[15:9] = (0000000B, 0000001B) is prohibited.

Remarks 1. When UART is used, the value of SDRmn[15:9] is the value of bits 15 to 9 of the SDRmn register (0000010B to 1111111B) and therefore is 2 to 127.

2. m: Unit number (m = 0, 1), n: Channel number (n = 0 to 3), mn = 00 to 03, 10 to 13

The operation clock (f_{MCK}) is determined by serial clock select register m (SPSm) and bit 15 (CKSmn) of serial mode register mn (SMRmn).

Table 12-4. Selection of Operation Clock For UART

SMRmn Register	SPSm Register								Operation Clock (f _{CLK}) ^{Note}	
	CKSmn	PRS m13	PRS m12	PRS m11	PRS m10	PRS m03	PRS m02	PRS m01	PRS m00	f _{CLK} = 32 MHz
0	X	X	X	X	0	0	0	0	f _{CLK}	32 MHz
	X	X	X	X	0	0	0	1	f _{CLK} /2	16 MHz
	X	X	X	X	0	0	1	0	f _{CLK} /2 ²	8 MHz
	X	X	X	X	0	0	1	1	f _{CLK} /2 ³	4 MHz
	X	X	X	X	0	1	0	0	f _{CLK} /2 ⁴	2 MHz
	X	X	X	X	0	1	0	1	f _{CLK} /2 ⁵	1 MHz
	X	X	X	X	0	1	1	0	f _{CLK} /2 ⁶	500 kHz
	X	X	X	X	0	1	1	1	f _{CLK} /2 ⁷	250 kHz
	X	X	X	X	1	0	0	0	f _{CLK} /2 ⁸	125 kHz
	X	X	X	X	1	0	0	1	f _{CLK} /2 ⁹	62.5 kHz
	X	X	X	X	1	0	1	0	f _{CLK} /2 ¹⁰	31.25 kHz
	X	X	X	X	1	0	1	1	f _{CLK} /2 ¹¹	15.63 kHz
	X	X	X	X	1	1	0	0	f _{CLK} /2 ¹²	7.81 kHz
	X	X	X	X	1	1	0	1	f _{CLK} /2 ¹³	3.91 kHz
	X	X	X	X	1	1	1	0	f _{CLK} /2 ¹⁴	1.95 kHz
X	X	X	X	1	1	1	1	f _{CLK} /2 ¹⁵	977 Hz	
1	0	0	0	0	X	X	X	X	f _{CLK}	32 MHz
	0	0	0	1	X	X	X	X	f _{CLK} /2	16 MHz
	0	0	1	0	X	X	X	X	f _{CLK} /2 ²	8 MHz
	0	0	1	1	X	X	X	X	f _{CLK} /2 ³	4 MHz
	0	1	0	0	X	X	X	X	f _{CLK} /2 ⁴	2 MHz
	0	1	0	1	X	X	X	X	f _{CLK} /2 ⁵	1 MHz
	0	1	1	0	X	X	X	X	f _{CLK} /2 ⁶	500 kHz
	0	1	1	1	X	X	X	X	f _{CLK} /2 ⁷	250 kHz
	1	0	0	0	X	X	X	X	f _{CLK} /2 ⁸	125 kHz
	1	0	0	1	X	X	X	X	f _{CLK} /2 ⁹	62.5 kHz
	1	0	1	0	X	X	X	X	f _{CLK} /2 ¹⁰	31.25 kHz
	1	0	1	1	X	X	X	X	f _{CLK} /2 ¹¹	15.63 kHz
	1	1	0	0	X	X	X	X	f _{CLK} /2 ¹²	7.81 kHz
	1	1	0	1	X	X	X	X	f _{CLK} /2 ¹³	3.91 kHz
	1	1	1	0	X	X	X	X	f _{CLK} /2 ¹⁴	1.95 kHz
1	1	1	1	X	X	X	X	f _{CLK} /2 ¹⁵	977 Hz	
Other than above									Setting prohibited	

Note When changing the clock selected for f_{CLK} (by changing the system clock control register (CKC) value), do so after having stopped (serial channel stop register m (STm) = 000FH) the operation of the serial array unit (SAU).

Remarks 1. X: Don't care

2. m: Unit number (m = 0, 1), n: Channel number (n = 0 to 3), mn = 00 to 03, 10 to 13

(2) Baud rate error during transmission

The baud rate error of UART (UART0 to UART3) communication during transmission can be calculated by the following expression. Make sure that the baud rate at the transmission side is within the permissible baud rate range at the reception side.

$$(\text{Baud rate error}) = (\text{Calculated baud rate value}) \div (\text{Target baud rate}) \times 100 - 100 [\%]$$

Here is an example of setting a UART baud rate at $f_{\text{CLK}} = 32 \text{ MHz}$.

UART Baud Rate (Target Baud Rate)	$f_{\text{CLK}} = 32 \text{ MHz}$			
	Operation Clock (f_{MCK})	SDRmn[15:9]	Calculated Baud Rate	Error from Target Baud Rate
300 bps	$f_{\text{CLK}}/2^9$	103	300.48 bps	+0.16%
600 bps	$f_{\text{CLK}}/2^8$	103	600.96 bps	+0.16%
1200 bps	$f_{\text{CLK}}/2^7$	103	1201.92 bps	+0.16%
2400 bps	$f_{\text{CLK}}/2^6$	103	2403.85 bps	+0.16%
4800 bps	$f_{\text{CLK}}/2^5$	103	4807.69 bps	+0.16%
9600 bps	$f_{\text{CLK}}/2^4$	103	9615.38 bps	+0.16%
19200 bps	$f_{\text{CLK}}/2^3$	103	19230.8 bps	+0.16%
31250 bps	$f_{\text{CLK}}/2^3$	63	31250.0 bps	$\pm 0.0\%$
38400 bps	$f_{\text{CLK}}/2^2$	103	38461.5 bps	+0.16%
76800 bps	$f_{\text{CLK}}/2$	103	76923.1 bps	+0.16%
153600 bps	f_{CLK}	103	153846 bps	+0.16%
312500 bps	f_{CLK}	50	313725.5 bps	+0.39%

Remark m: Unit number (m = 0, 1), n: Channel number (n = 0, 2), mn = 00, 02, 10, 12

(3) Permissible baud rate range for reception

The permissible baud rate range for reception during UART (UART0 to UART3) communication can be calculated by the following expression. Make sure that the baud rate at the transmission side is within the permissible baud rate range at the reception side.

$$\text{(Maximum receivable baud rate)} = \frac{2 \times k \times \text{Nfr}}{2 \times k \times \text{Nfr} - k + 2} \times \text{Brate}$$

$$\text{(Minimum receivable baud rate)} = \frac{2 \times k \times (\text{Nfr} - 1)}{2 \times k \times \text{Nfr} - k - 2} \times \text{Brate}$$

Brate: Calculated baud rate value at the reception side (See **12.6.4 (1) Baud rate calculation expression.**)

k: SDRmn[15:9] + 1

Nfr: 1 data frame length [bits]
 = (Start bit) + (Data length) + (Parity bit) + (Stop bit)

Remark m: Unit number (m = 0, 1), n: Channel number (n = 1, 3), mn = 01, 03, 11, 13

Figure 12-95. Permissible Baud Rate Range for Reception (1 Data Frame Length = 11 Bits)

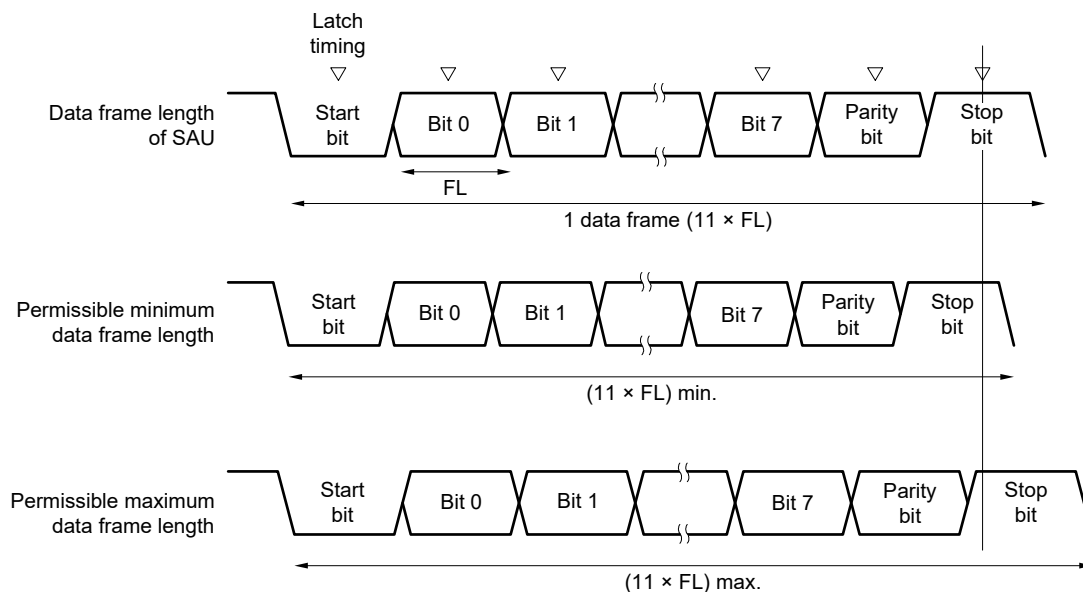

As shown in Figure 12-95, the timing of latching receive data is determined by the division ratio set by bits 15 to 9 of serial data register mn (SDRmn) after the start bit is detected. If the last data (stop bit) is received before this latch timing, the data can be correctly received.

12.6.5 Procedure for processing errors that occurred during UART (UART0 to UART3) communication

The procedure for processing errors that occurred during UART (UART0 to UART3) communication is described in Figures 12-96 and 12-97.

Figure 12-96. Processing Procedure in Case of Parity Error or Overrun Error

Software Manipulation	Hardware Status	Remark
Reads serial data register mn (SDRmn).	→ The BFFmn bit of the SSRmn register is set to 0 and channel n is enabled to receive data.	This is to prevent an overrun error if the next reception is completed during error processing.
Reads serial status register mn (SSRmn).		The error type is identified and the read value is used to clear the error flag.
Writes 1 to serial flag clear trigger register mn (SIRmn).	→ The error flag is cleared.	The error can be cleared only during reading, by writing the value read from the SSRmn register to the SIRmn register without modification.

Figure 12-97. Processing Procedure in Case of Framing Error

Software Manipulation	Hardware Status	Remark
Reads serial data register mn (SDRmn).	→ The BFFmn bit of the SSRmn register is set to 0 and channel n is enabled to receive data.	This is to prevent an overrun error if the next reception is completed during error processing.
Reads serial status register mn (SSRmn).		The error type is identified and the read value is used to clear the error flag.
Writes serial flag clear trigger register mn (SIRmn).	→ The error flag is cleared.	The error can be cleared only during reading, by writing the value read from the SSRmn register to the SIRmn register without modification.
Sets the STmn bit of serial channel stop register m (STm) to 1.	→ The SEmn bit of serial channel enable status register m (SEm) is set to 0 and channel n stops operating.	
Synchronization with other party of communication		Synchronization with the other party of communication is re-established and communication is resumed because it is considered that a framing error has occurred because the start bit has been shifted.
Sets the SSmn bit of serial channel start register m (SSm) to 1.	→ The SEmn bit of serial channel enable status register m (SEm) is set to 1 and channel n is enabled to operate.	

Remark m: Unit number (m = 0, 1), n: Channel number (n = 0 to 3), mn = 00 to 03, 10 to 13

12.7 LIN Communication Operation

12.7.1 LIN transmission

Of UART transmission, UART2 of the 30, 32, 36, 40, 44, 48, 52, 64, 80, 100, and 128-pin products support LIN communication.

For LIN transmission, channel 0 of unit 1 is used.

UART	UART0	UART1	UART2	UART3
Support of LIN communication	Not supported	Not supported	Supported	Not supported
Target channel	–	–	Channel 0 of SAU1	–
Pins used	–	–	TxD2	–
Interrupt	–	–	INTST2	–
	Transfer end interrupt (in single-transfer mode) or buffer empty interrupt (in continuous transfer mode) can be selected.			
Error detection flag	None			
Transfer data length	8 bits			
Transfer rate ^{Note}	Max. $f_{MCK}/6$ [bps] (SDR10 [15:9] = 2 or more), Min. $f_{CLK}/(2 \times 2^{15} \times 128)$ [bps]			
Data phase	Non-reverse output (default: high level) Reverse output (default: low level)			
Parity bit	No parity bit			
Stop bit	Appending 1 bit			
Data direction	LSB first			

Note Use this operation within a range that satisfies the conditions above and the peripheral functions characteristics in the electrical specifications (see **CHAPTER 29 ELECTRICAL SPECIFICATIONS** ($T_A = -40$ to $+85^\circ\text{C}$) and **CHAPTER 30 ELECTRICAL SPECIFICATIONS (G: INDUSTRIAL APPLICATIONS** $T_A = -40$ to $+105^\circ\text{C}$)). In general, 2.4/9.6/19.2 kbps is often used in LIN communication.

Remark f_{MCK} : Operation clock frequency of target channel
 f_{CLK} : System clock frequency

LIN stands for Local Interconnect Network and is a low-speed (1 to 20 kbps) serial communication protocol designed to reduce the cost of an automobile network.

Communication of LIN is single-master communication and up to 15 slaves can be connected to one master.

The slaves are used to control switches, actuators, and sensors, which are connected to the master via LIN.

Usually, the master is connected to a network such as CAN (Controller Area Network).

A LIN bus is a single-wire bus to which nodes are connected via transceiver conforming to ISO9141.

According to the protocol of LIN, the master transmits a frame by attaching baud rate information to it. A slave receives this frame and corrects a baud rate error from the master. If the baud rate error of a slave is within ±15%, communication can be established.

Figure 12-98 outlines a transmission operation of LIN.

Figure 12-98. Transmission Operation of LIN

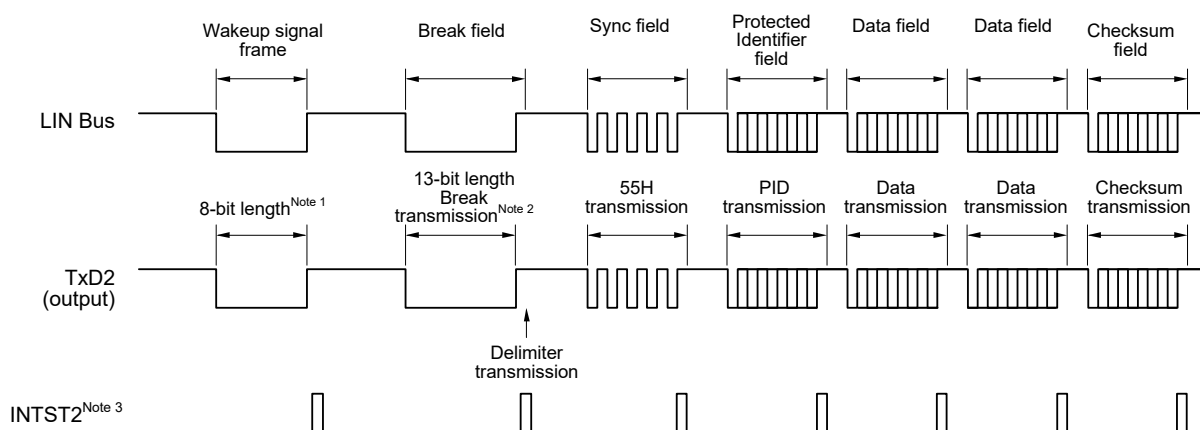

- Notes**
1. Set the baud rate in accordance with the wakeup signal regulations and transmit data of 80H.
 2. A break field is defined to have a width of 13 bits and output a low level. Where the baud rate for main transfer is N [bps], therefore, the baud rate of the break field is calculated as follows.

$$\text{(Baud rate of break field)} = 9/13 \times N$$
 By transmitting data of 00H at this baud rate, a break field is generated.
 3. INTST2 is output upon completion of transmission. INTST2 is also output at BF transmission.

Remark The interval between fields is controlled by software.

Figure 12-99. Flowchart for LIN Transmission

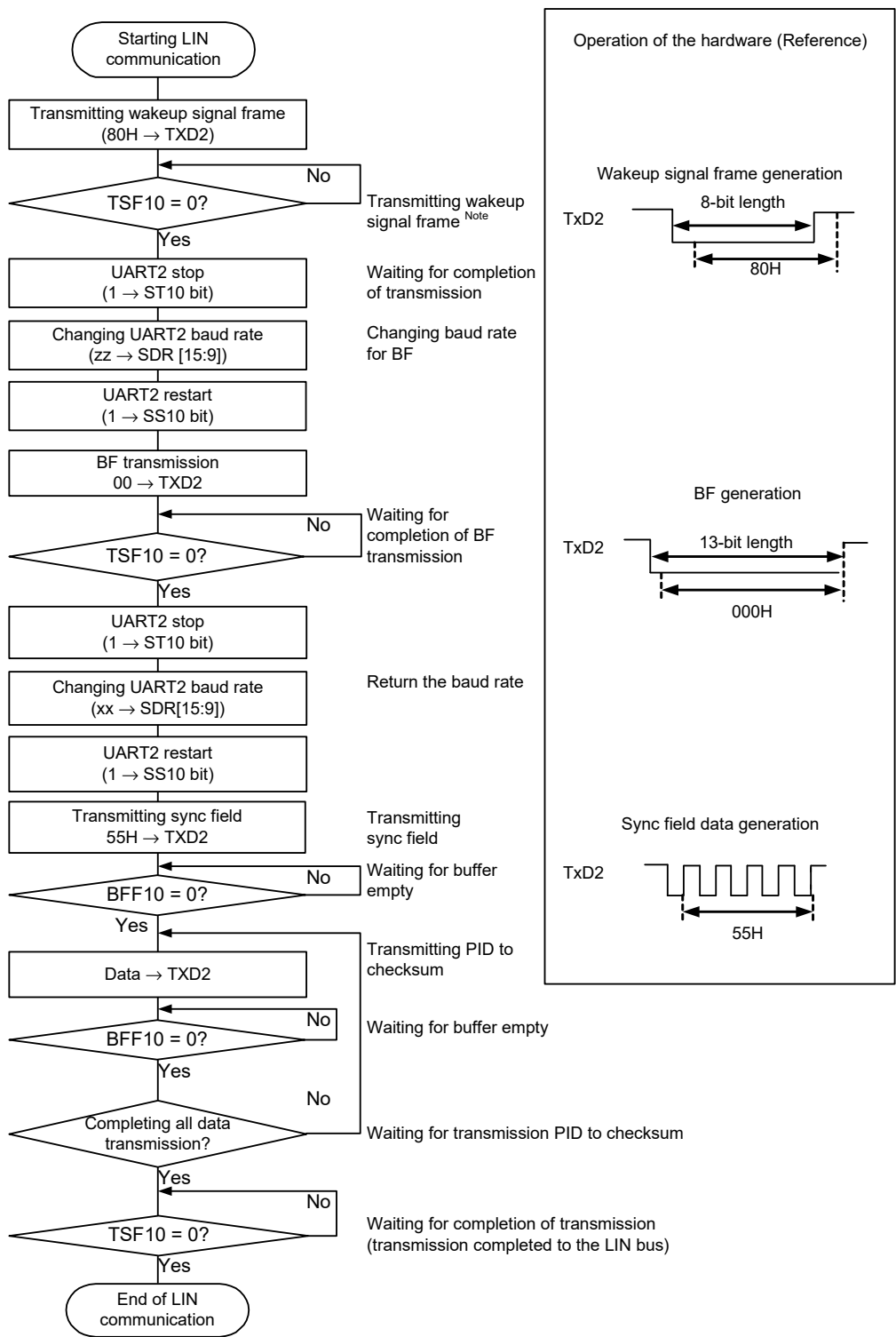

Note When LIN-bus start from sleep status only

Remark Default setting of the UART is complete, and the flow from the transmission enable status.

12.7.2 LIN reception

Of UART reception, UART2 of the 30, 32, 36, 40, 44, 48, 52, 64, 80, 100, and 128-pin products support LIN communication.

For LIN reception, channel 1 of unit 1 is used.

UART	UART0	UART1	UART2	UART3
Support of LIN communication	Not supported	Not supported	Supported	Not supported
Target channel	–	–	Channel 1 of SAU1	–
Pins used	–	–	RxD2	–
Interrupt	–	–	INTSR2	–
	Transfer end interrupt only (Setting the buffer empty interrupt is prohibited.)			
Error interrupt	–	–	INTSRE2	–
Error detection flag	<ul style="list-style-type: none"> • Framing error detection flag (FEF11) • Overrun error detection flag (OVF11) 			
Transfer data length	8 bits			
Transfer rate ^{Note}	Max. $f_{MCK}/6$ [bps] (SDR11 [15:9] = 2 or more), Min. $f_{CLK}/(2 \times 2^{15} \times 128)$ [bps]			
Data phase	Non-reverse output (default: high level) Reverse output (default: low level)			
Parity bit	No parity bit (The parity bit is not checked.)			
Stop bit	Check the first bit			
Data direction	LSB first			

Note Use this operation within a range that satisfies the conditions above and the peripheral functions characteristics in the electrical specifications (see **CHAPTER 29 ELECTRICAL SPECIFICATIONS (T_A = -40 to +85°C)** and **CHAPTER 30 ELECTRICAL SPECIFICATIONS (G: INDUSTRIAL APPLICATIONS T_A = -40 to +105°C)**).

Remark f_{MCK} : Operation clock frequency of target channel
 f_{CLK} : System clock frequency

Figure 12-100 outlines a reception operation of LIN.

Figure 12-100. Reception Operation of LIN

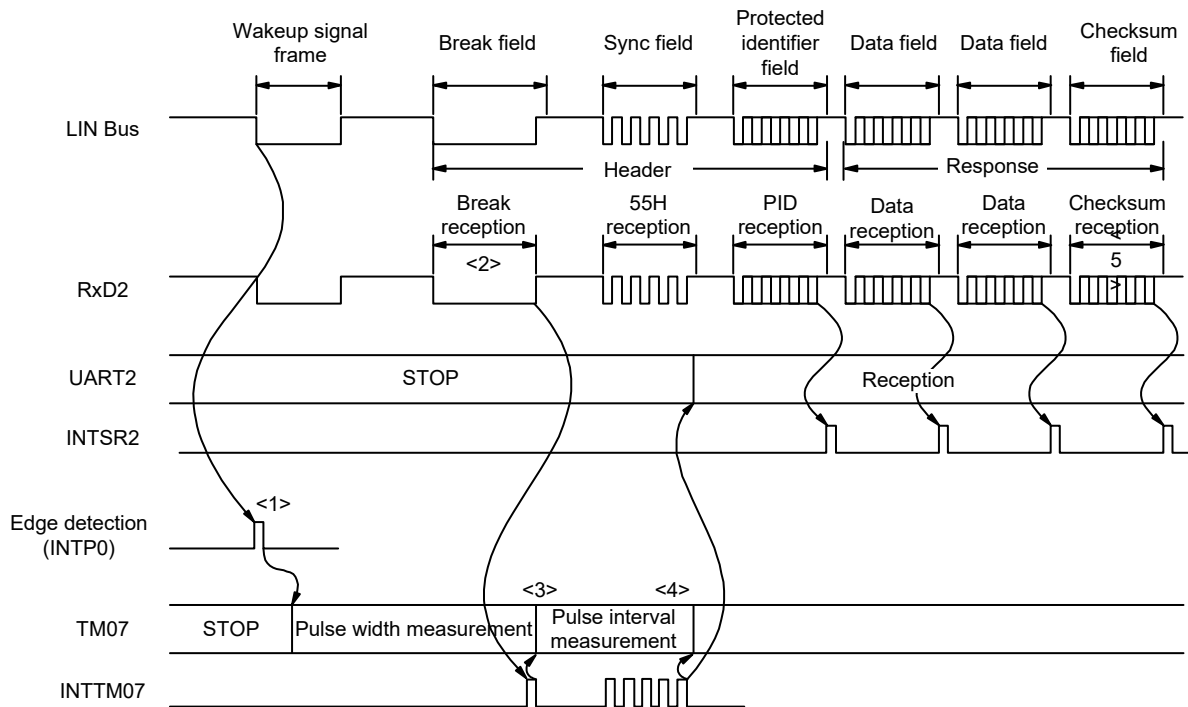

Here is the flow of reception processing.

- <1> The wakeup signal is detected by detecting an interrupt edge (INTP0) on a pin. When the wakeup signal is detected, change TM07 to pulse width measurement upon detection of the wakeup signal to measure the low-level width of the BF signal. Then wait for BF signal reception.
- <2> TM07 starts measuring the low-level width upon detection of the falling edge of the BF signal, and then captures the data upon detection of the rising edge of the BF signal. The captured data is used to judge whether it is the BF signal.
- <3> When the BF signal has been received normally, change TM07 to pulse interval measurement and measure the interval between the falling edges of the RxD2 signal in the Sync field four times.
- <4> When BF reception has been correctly completed, start channel 7 of the timer array unit and measure the bit interval (pulse width) of the sync field (see **6.8.4 Operation as input pulse interval measurement**).
- <5> Calculate a baud rate error from the bit interval of sync field (SF). Stop UART2 once and adjust (re-set) the baud rate.
- <6> The checksum field should be distinguished by software. In addition, processing to initialize UART2 after the checksum field is received and to wait for reception of BF should also be performed by software.

Figure 12-101. Flowchart for LIN Reception

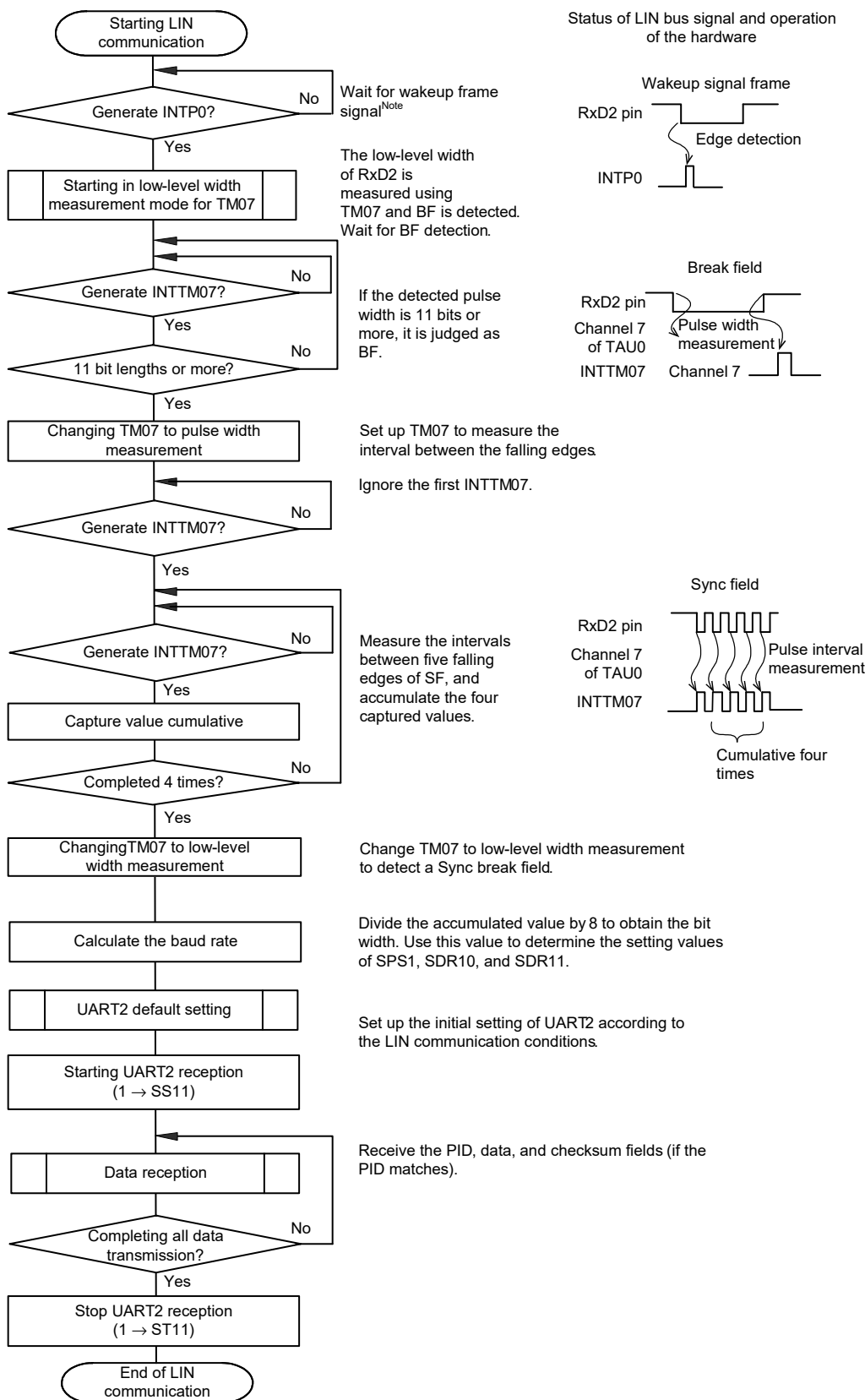

Note Required in the sleep status only.

Figure 12-102 and Figure 12-103 show the configuration of a port that manipulates reception of LIN.

The wakeup signal transmitted from the master of LIN is received by detecting an edge of an external interrupt (INTP0). The length of the sync field transmitted from the master can be measured by using the external event capture operation of the timer array unit 0 to calculate a baud-rate error.

By controlling switch of port input (ISC0/ISC1), the input source of port input (RxD2) for reception can be input to the external interrupt pin (INTP0) and timer array unit

Figure 12-102. Port Configuration for Manipulating Reception of LIN (30, 32, 36, 40-pin)

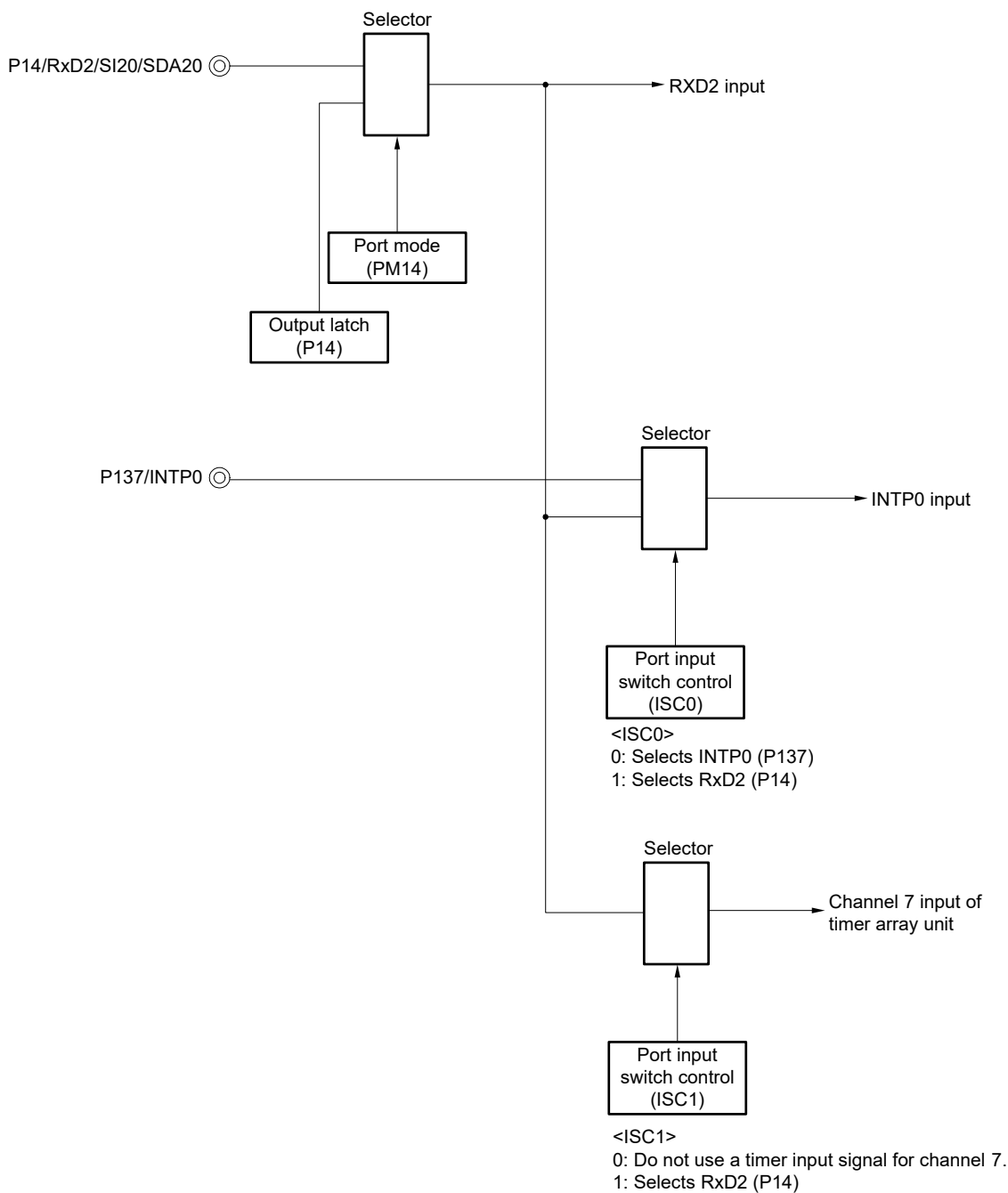

Remark ISC0, ISC1: Bits 0 and 1 of the input switch control register (ISC) (See Figure 12-21.)

Figure 12-103. Port Configuration for Manipulating Reception of LIN (44, 48, 52, 64-pin)

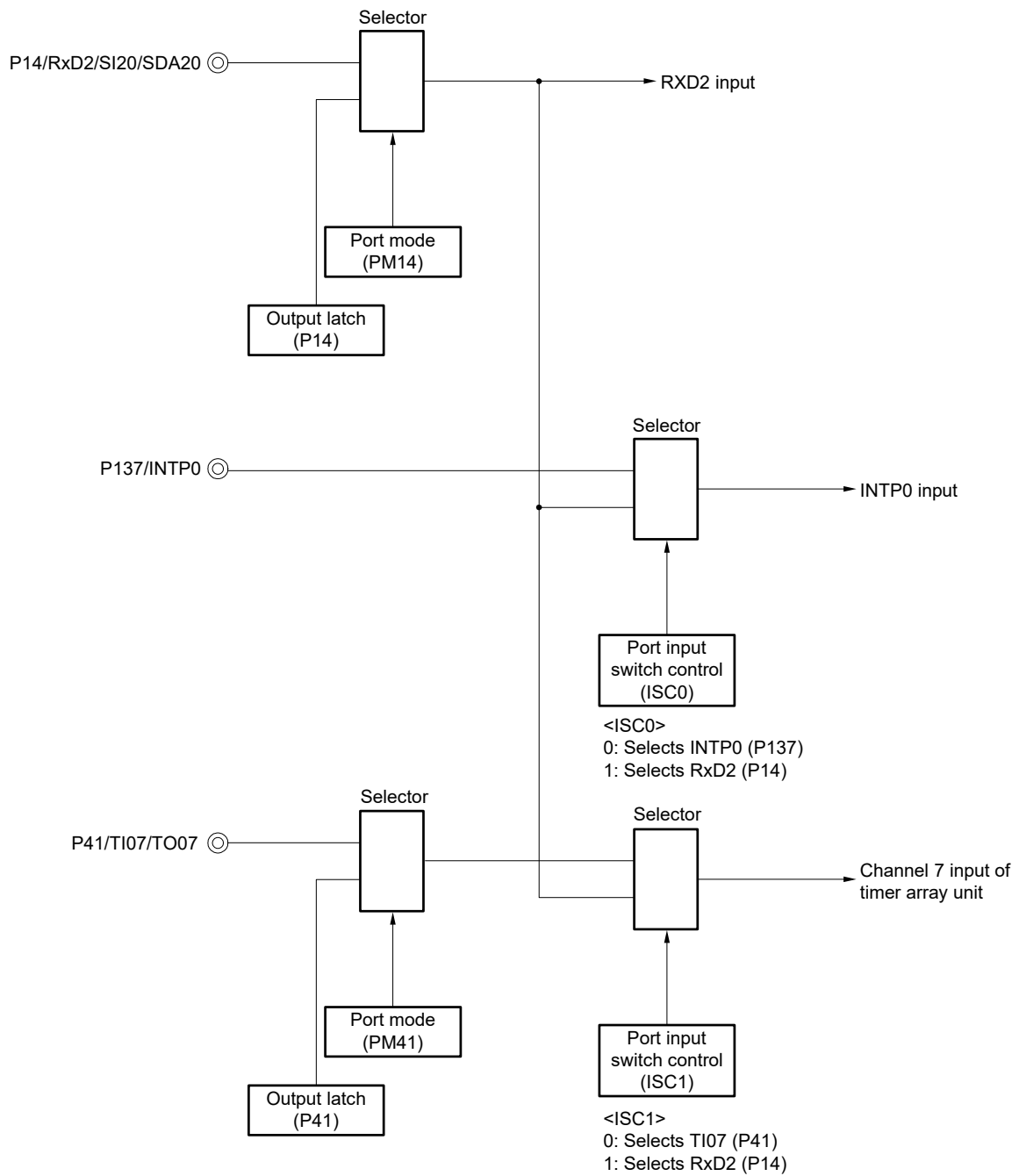

Remark ISC0, ISC1: Bits 0 and 1 of the input switch control register (ISC) (See Figure 12-21.)

The peripheral functions used for the LIN communication operation are as follows.

<Peripheral functions used>

- External interrupt (INTP0); Wakeup signal detection
Usage: To detect an edge of the wakeup signal and the start of communication
- Channel 7 of timer array unit; Baud rate error detection, break field detection.
Usage: To detect the length of the sync field (SF) and divide it by the number of bits in order to detect an error (The interval of the edge input to RxD2 is measured in the capture mode.)
Measured the low-level width, determine whether break field (BF).
- Channels 0 and 1 (UART2) of serial array unit 1 (SAU1)

12.8 Operation of Simplified I²C (IIC00, IIC01, IIC10, IIC11, IIC20, IIC21, IIC30, IIC31) Communication

This is a clocked communication function to communicate with two or more devices by using two lines: serial clock (SCL) and serial data (SDA). This communication function is designed to execute single communication with devices such as EEPROM, flash memory, and A/D converter, and therefore, can be used only by the master.

Operate the control registers by software for setting the start and stop conditions while observing the specifications of the I²C bus line

[Data transmission/reception]

- Master transmission, master reception (only master function with a single master)
- ACK output function ^{Note} and ACK detection function
- Data length of 8 bits
(When an address is transmitted, the address is specified by the higher 7 bits, and the least significant bit is used for R/W control.)
- Generation of start condition and stop condition for software

[Interrupt function]

- Transfer end interrupt

[Error detection flag]

- Overrun error
- ACK error

* [Functions not supported by simplified I²C]

- Slave transmission, slave reception
- Multi-master function (arbitration loss detection function)
- Wait detection function

Note When receiving the last data, ACK will not be output if 0 is written to the SOEmn (SOEm register) bit and serial communication data output is stopped. See the processing flow in **12.8.3 (2)** for details.

Remark m: Unit number (m = 0, 1), n: Channel number (n = 0 to 3), mn = 00 to 03, 10 to 13

The channel supporting simplified I²C (IIC00, IIC01, IIC10, IIC11, IIC20, IIC21, IIC30, IIC31) is channels 0 to 3 of SAU0 and channel 0 and 1 of SAU1.

- 20, 24, 25-pin products

Unit	Channel	Used as simplified SPI (CSI)	Used as UART	Used as Simplified I ² C
0	0	CSI00	UART0	IIC00
	1	–		–
	2	–	UART1	–
	3	CSI11		IIC11

- 30, 32-pin products

Unit	Channel	Used as simplified SPI (CSI)	Used as UART	Used as Simplified I ² C
0	0	CSI00	UART0	IIC00
	1	–		–
	2	–	UART1	–
	3	CSI11		IIC11
1	0	CSI20	UART2 (supporting LIN-bus)	IIC20
	1	–		–

- 36, 40, 44-pin products

Unit	Channel	Used as simplified SPI (CSI)	Used as UART	Used as Simplified I ² C
0	0	CSI00	UART0	IIC00
	1	–		–
	2	–	UART1	–
	3	CSI11		IIC11
1	0	CSI20	UART2 (supporting LIN-bus)	IIC20
	1	CSI21		IIC21

- 48, 52-pin products

Unit	Channel	Used as simplified SPI (CSI)	Used as UART	Used as Simplified I ² C
0	0	CSI00	UART0	IIC00
	1	CSI01		IIC01
	2	–	UART1	–
	3	CSI11		IIC11
1	0	CSI20	UART2 (supporting LIN-bus)	IIC20
	1	CSI21		IIC21

- 64-pin products

Unit	Channel	Used as simplified SPI (CSI)	Used as UART	Used as Simplified I ² C
0	0	CSI00	UART0	IIC00
	1	CSI01		IIC01
	2	CSI10	UART1	IIC10
	3	CSI11		IIC11
1	0	CSI20	UART2 (supporting LIN-bus)	IIC20
	1	CSI21		IIC21

- 80, 100, 128-pin products

Unit	Channel	Used as simplified SPI (CSI)	Used as UART	Used as Simplified I ² C
0	0	CSI00	UART0	IIC00
	1	CSI01		IIC01
	2	CSI10	UART1	IIC10
	3	CSI11		IIC11
1	0	CSI20	UART2 (supporting LIN-bus)	IIC20
	1	CSI21		IIC21
	2	CSI30	UART3	IIC30
	3	CSI31		IIC31

Simplified I²C (IIC00, IIC01, IIC10, IIC11, IIC20, IIC21, IIC30, IIC31) performs the following four types of communication operations.

- Address field transmission (See 12.8.1.)
- Data transmission (See 12.8.2.)
- Data reception (See 12.8.3.)
- Stop condition generation (See 12.8.4.)

12.8.1 Address field transmission

Address field transmission is a transmission operation that first executes in I²C communication to identify the target for transfer (slave). After a start condition is generated, an address (7 bits) and a transfer direction (1 bit) are transmitted in one frame.

Simplified I ² C	IIC00	IIC01	IIC10	IIC11	IIC20	IIC21	IIC30	IIC31
Target channel	Channel 0 of SAU0	Channel 1 of SAU0	Channel 2 of SAU0	Channel 3 of SAU0	Channel 0 of SAU1	Channel 1 of SAU1	Channel 2 of SAU1	Channel 3 of SAU1
Pins used	SCL00, SDA00 ^{Note 1}	SCL01, SDA01 ^{Note 1}	SCL10, SDA10 ^{Note 1}	SCL11, SDA11 ^{Note 1}	SCL20, SDA20 ^{Note 1}	SCL21, SDA21 ^{Note 1}	SCL30, SDA30 ^{Note 1}	SCL31, SDA31 ^{Note 1}
Interrupt	INTIIC00	INTIIC01	INTIIC10	INTIIC11	INTIIC20	INTIIC21	INTIIC30	INTIIC31
	Transfer end interrupt only (Setting the buffer empty interrupt is prohibited.)							
Error detection flag	ACK error detection flag (PEFmn)							
Transfer data length	8 bits (transmitted with specifying the higher 7 bits as address and the least significant bit as R/W control)							
Transfer rate ^{Note 2}	Max. $f_{MCK}/4$ [Hz] (SDRmn[15:9] = 1 or more) f_{MCK} : Operation clock frequency of target channel However, the following condition must be satisfied in each mode of I ² C. <ul style="list-style-type: none"> • Max. 1 MHz (fast mode plus) • Max. 400 kHz (fast mode) • Max. 100 kHz (standard mode) 							
Data level	Non-reversed output (default: high level)							
Parity bit	No parity bit							
Stop bit	Appending 1 bit (for ACK transmission/reception timing)							
Data direction	MSB first							

Notes 1. To perform communication via simplified I²C, set the N-ch open-drain output (V_{DD} tolerance (20 to 52-pin products)/ EV_{DD} tolerance (64 to 128-pin products)) mode (POMxx = 1) with the port output mode register (POMxx). For details, see **4.3 Registers Controlling Port Function** and **4.5 Register Settings When Using Alternate Function**.

When IIC00, IIC10, IIC20, IIC30, IIC31 is communicating with an external device with a different potential, set the N-ch open-drain output (V_{DD} tolerance (20 to 52-pin products)/ EV_{DD} tolerance (64 to 128-pin products)) mode (POMxx = 1) also for the clock input/output pins (SCL00, SCL10, SCL20, SCL30, SCL31).

For details, see **4.4.5 Handling different potential (1.8 V, 2.5 V, 3 V) by using I/O buffers**.

2. Use this operation within a range that satisfies the conditions above and the peripheral functions characteristics in the electrical specifications (see **CHAPTER 29 ELECTRICAL SPECIFICATIONS (T_A = -40 to +85°C)** and **CHAPTER 30 ELECTRICAL SPECIFICATIONS (G: INDUSTRIAL APPLICATIONS T_A = -40 to +105°C)**).

Remark m: Unit number (m = 0, 1), n: Channel number (n = 0 to 3), mn = 00 to 03, 10 to 13

(1) Register setting

Figure 12-104. Example of Contents of Registers for Address Field Transmission of Simplified I²C (IIC00, IIC01, IIC10, IIC11, IIC20, IIC21, IIC30, IIC31)

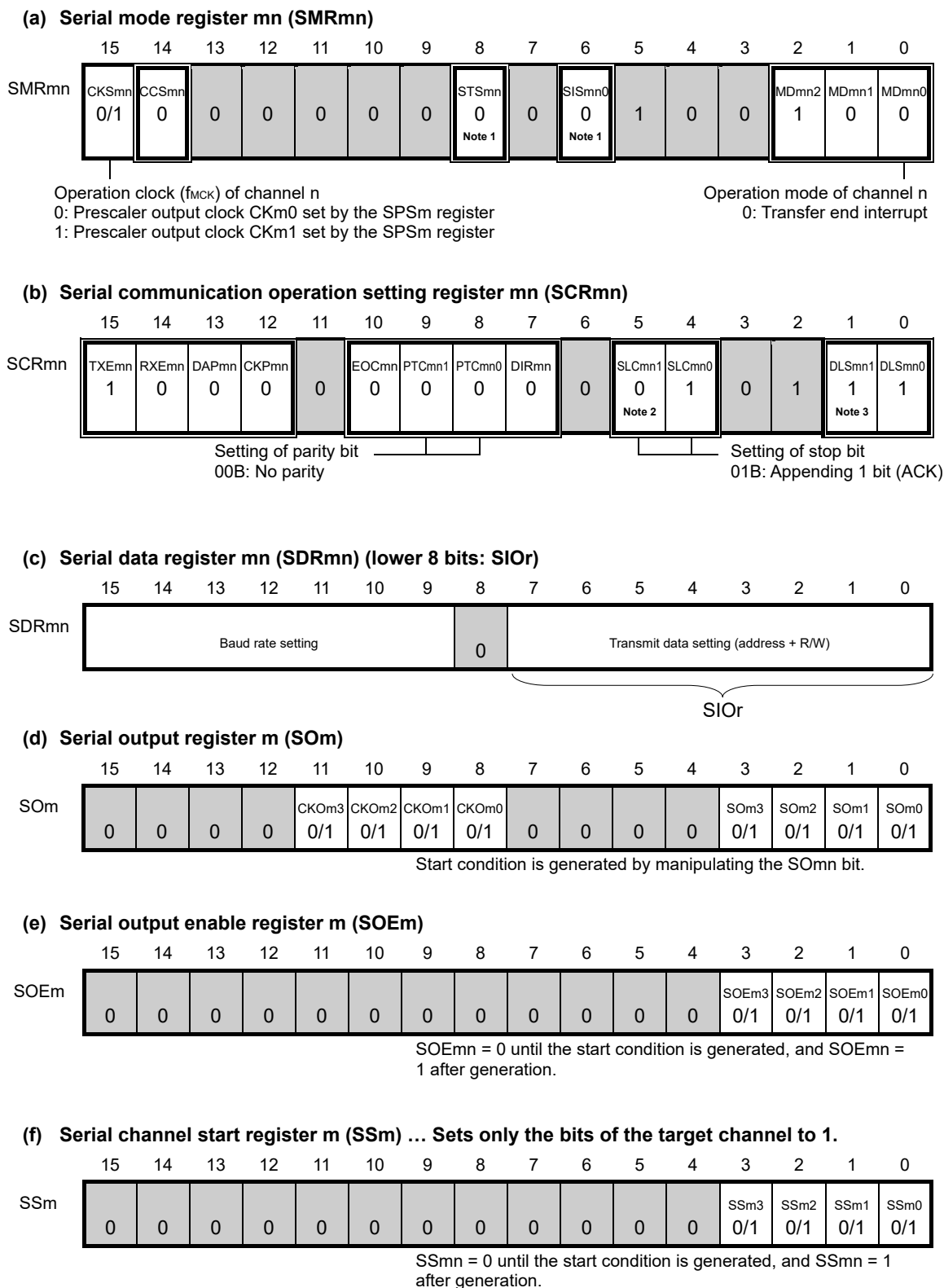

(Notes and Remarks are listed on the next page.)

- Notes**
1. Only provided for the SMR00, SMR03, SMR11, and SMR13 registers.
 2. Only provided for the SCR00, SCR02, SCR10, and SCR12 registers.
 3. Only provided for the SCR00 and SCR01 registers and the SCR10 and SCR11 registers of 80- to 128-pin products. This bit is fixed to 1 for the other registers.

- Remarks**
1. m: Unit number (m = 0, 1), n: Channel number (n = 0 to 3), r: IIC number (r = 00, 01, 10, 11, 20, 21, 30, 31), mn = 00 to 03, 10 to 13
 2. : Setting is fixed in the IIC mode, : Setting disabled (set to the initial value)
0/1: Set to 0 or 1 depending on the usage of the user

(2) Operation procedure

Figure 12-105. Initial Setting Procedure for Simplified I²C Address Field Transmission

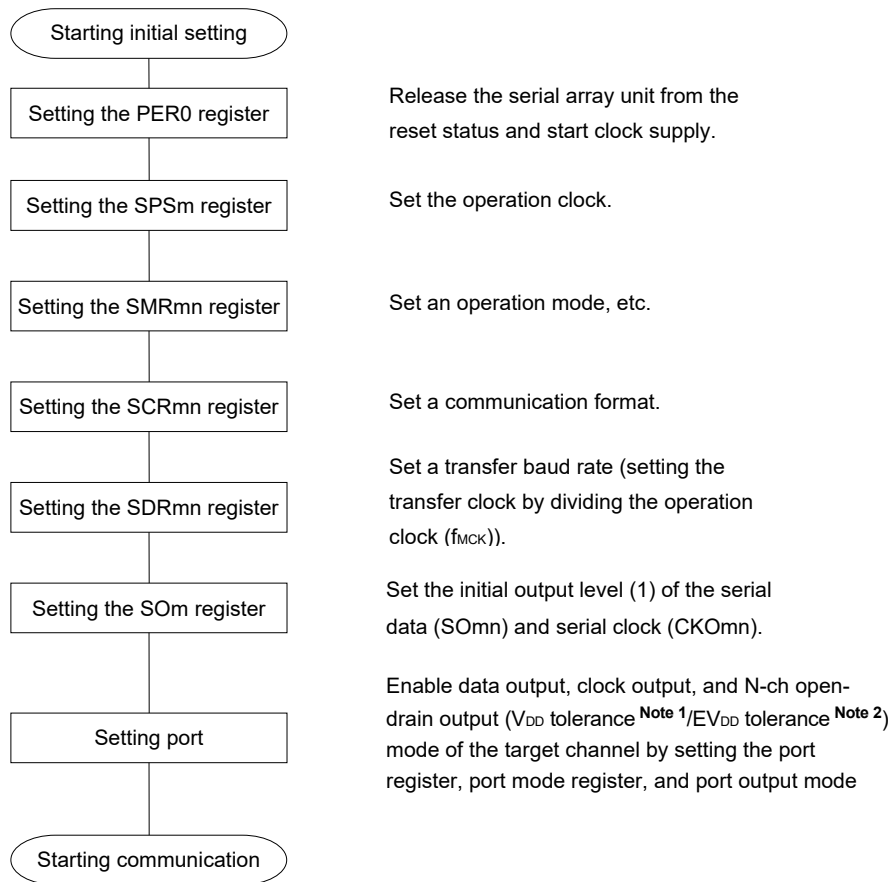

- Notes**
1. 20 to 52-pin products
 2. 64 to 128-pin products

(3) Processing flow

Figure 12-106. Timing Chart of Address Field Transmission

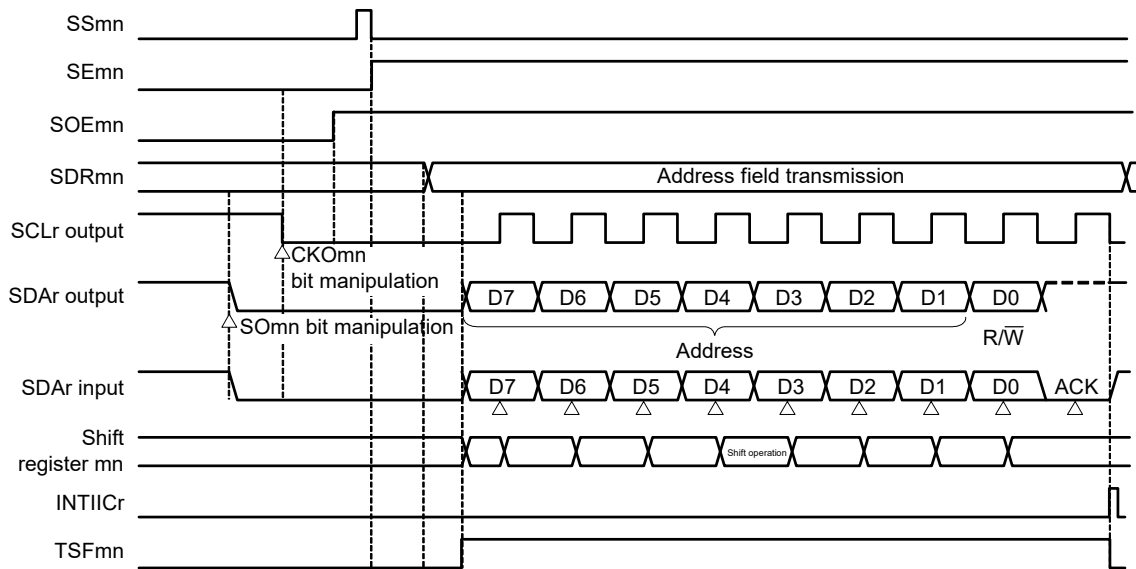

Remark m: Unit number (m = 0, 1), n: Channel number (n = 0 to 3), r: IIC number (r = 00, 01, 10, 11, 20, 21, 30, 31), mn = 00 to 03, 10 to 13

Figure 12-107. Flowchart of Simplified I²C Address Field Transmission

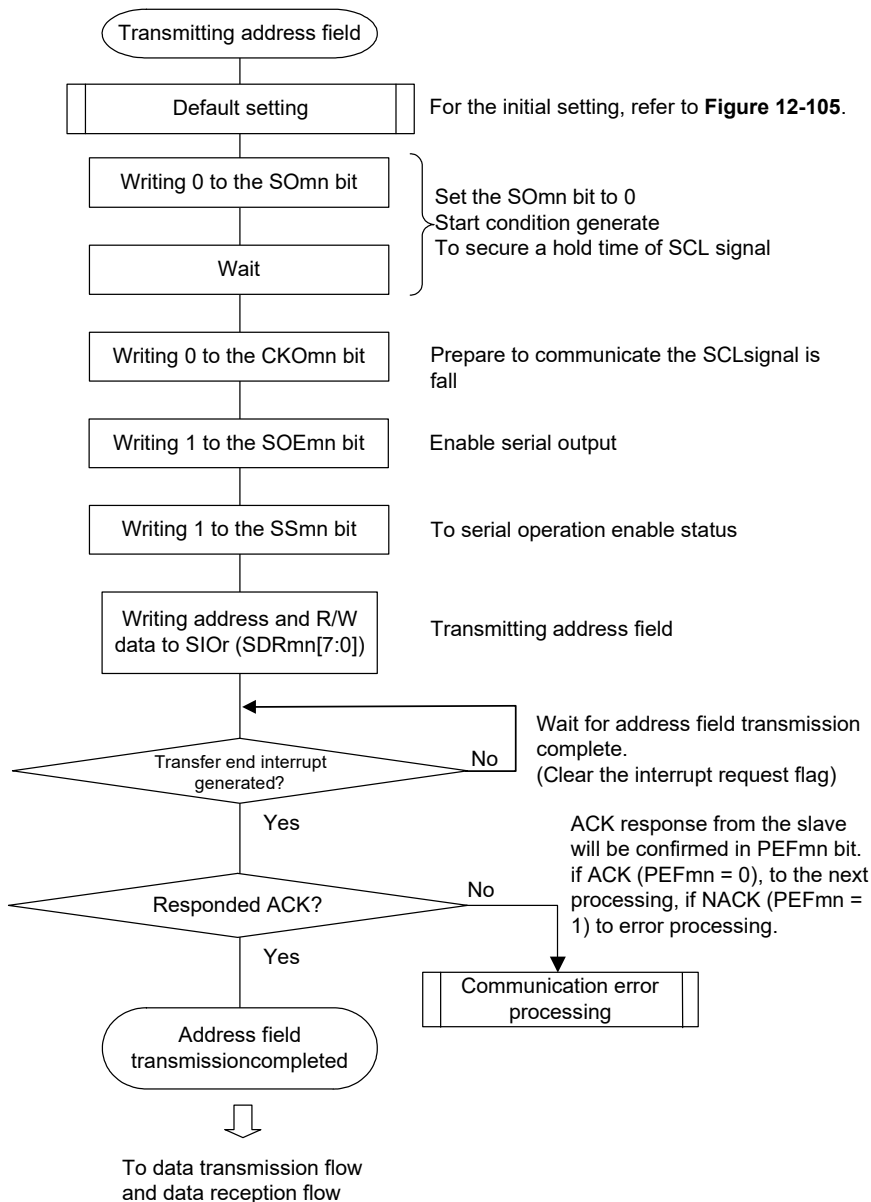

12.8.2 Data transmission

Data transmission is an operation to transmit data to the target for transfer (slave) after transmission of an address field. After all data are transmitted to the slave, a stop condition is generated and the bus is released.

Simplified I ² C	IIC00	IIC01	IIC10	IIC11	IIC20	IIC21	IIC30	IIC31
Target channel	Channel 0 of SAU0	Channel 1 of SAU0	Channel 2 of SAU0	Channel 3 of SAU0	Channel 0 of SAU1	Channel 1 of SAU1	Channel 2 of SAU1	Channel 3 of SAU1
Pins used	SCL00, SDA00 ^{Note 1}	SCL01, SDA01 ^{Note 1}	SCL10, SDA10 ^{Note 1}	SCL11, SDA11 ^{Note 1}	SCL20, SDA20 ^{Note 1}	SCL21, SDA21 ^{Note 1}	SCL30, SDA30 ^{Note 1}	SCL31, SDA31 ^{Note 1}
Interrupt	INTIIC00	INTIIC01	INTIIC10	INTIIC11	INTIIC20	INTIIC21	INTIIC30	INTIIC31
	Transfer end interrupt only (Setting the buffer empty interrupt is prohibited.)							
Error detection flag	ACK error flag (PEFmn)							
Transfer data length	8 bits							
Transfer rate ^{Note 2}	Max. $f_{MCK}/4$ [Hz] (SDRmn[15:9] = 1 or more) f_{MCK} : Operation clock frequency of target channel However, the following condition must be satisfied in each mode of I ² C. <ul style="list-style-type: none"> • Max. 1 MHz (fast mode plus) • Max. 400 kHz (fast mode) • Max. 100 kHz (standard mode) 							
Data level	Non-reversed output (default: high level)							
Parity bit	No parity bit							
Stop bit	Appending 1 bit (for ACK reception timing)							
Data direction	MSB first							

Notes 1. To perform communication via simplified I²C, set the N-ch open-drain output (V_{DD} tolerance (20 to 52-pin products)/ EV_{DD} tolerance (64 to 128-pin products)) mode (POMxx = 1) with the port output mode register (POMxx). For details, see **4.3 Registers Controlling Port Function** and **4.5 Register Settings When Using Alternate Function**.

When IIC00, IIC10, IIC20, IIC30, IIC31 is communicating with an external device with a different potential, set the N-ch open-drain output (V_{DD} tolerance (20 to 52-pin products)/ EV_{DD} tolerance (64 to 128-pin products)) mode (POMxx = 1) also for the clock input/output pins (SCL00, SCL10, SCL20, SCL30, SCL31). For details, see **4.4.5 Handling different potential (1.8 V, 2.5 V, 3 V) by using I/O buffers**.

2. Use this operation within a range that satisfies the conditions above and the peripheral functions characteristics in the electrical specifications (see **CHAPTER 29 ELECTRICAL SPECIFICATIONS (T_A = -40 to +85°C)** and **CHAPTER 30 ELECTRICAL SPECIFICATIONS (G: INDUSTRIAL APPLICATIONS T_A = -40 to +105°C)**).

Remark m: Unit number (m = 0, 1), n: Channel number (n = 0 to 3), mn = 00 to 03, 10 to 13

(1) Register setting

Figure 12-108. Example of Contents of Registers for Data Transmission of Simplified I²C (IIC00, IIC01, IIC10, IIC11, IIC20, IIC21, IIC30, IIC31)

(a) Serial mode register mn (SMRmn) ... Do not manipulate this register during data transmission/reception.

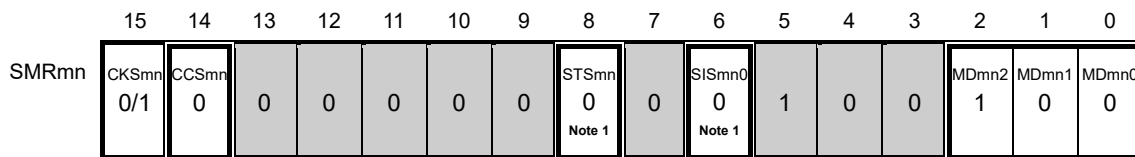

(b) Serial communication operation setting register mn (SCRmn) ... Do not manipulate the bits of this register, except the TXEmn and RXEmn bits, during data transmission/reception.

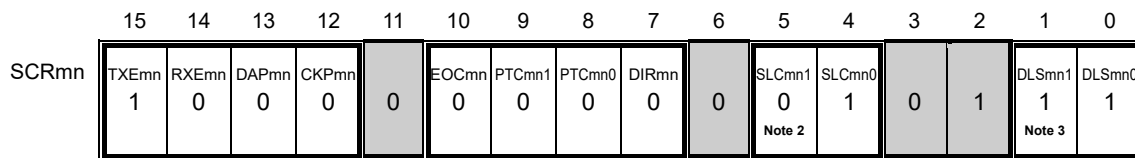

(c) Serial data register mn (SDRmn) (lower 8 bits: SIO_r) ... During data transmission/reception, valid only lower 8-bits (SIO_r)

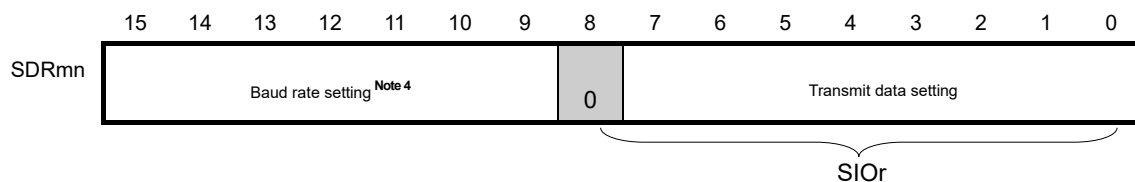

(d) Serial output register m (SOM) ... Do not manipulate this register during data transmission/reception.

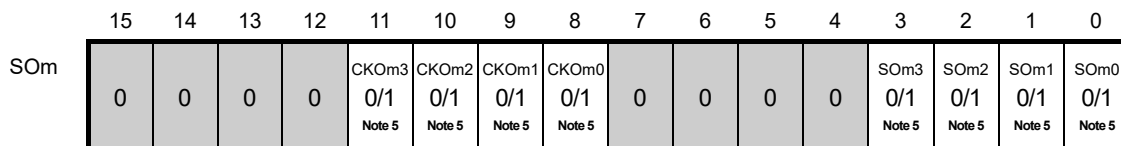

(e) Serial output enable register m (SOEm) ... Do not manipulate this register during data transmission/reception.

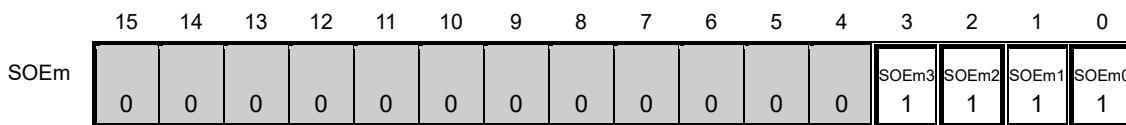

(f) Serial channel start register m (SSm) ... Do not manipulate this register during data transmission/reception.

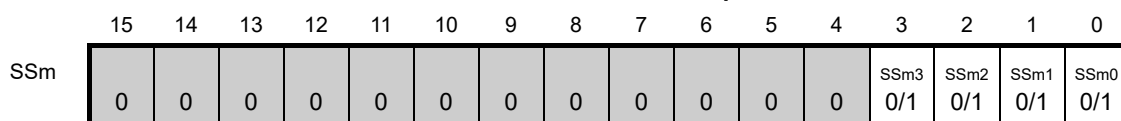

(Notes and Remarks are listed on the next page.)

- Notes**
1. Only provided for the SMR01, SMR03, SMR11, and SMR13 registers.
 2. Only provided for the SCR00, SCR02, SCR10, and SCR12 registers.
 3. Only provided for the SCR00 and SCR01 registers and the SCR10 and SCR11 registers of an 80- to 128-pin product. This bit is fixed to 1 for the other registers.
 4. Because the setting is completed by address field transmission, setting is not required.
 5. The value varies depending on the communication data during communication operation.

- Remarks**
1. m: Unit number (m = 0, 1), n: Channel number (n = 0 to 3), r: IIC number (r = 00, 01, 10, 11, 20, 21, 30, 31), mn = 00 to 03, 10 to 13
 2. : Setting is fixed in the IIC mode, : Setting disabled (set to the initial value)
0/1: Set to 0 or 1 depending on the usage of the user

(2) Processing flow

Figure 12-109. Timing Chart of Data Transmission

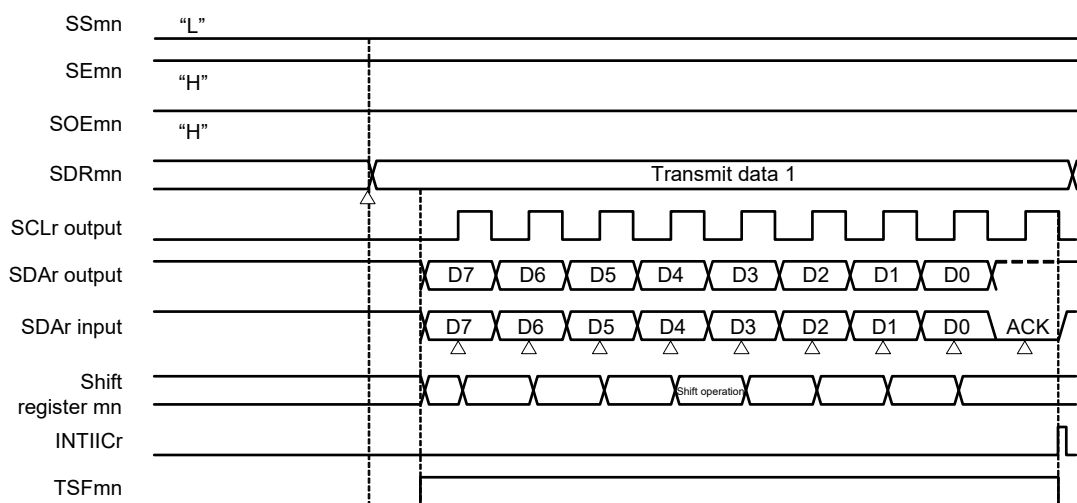
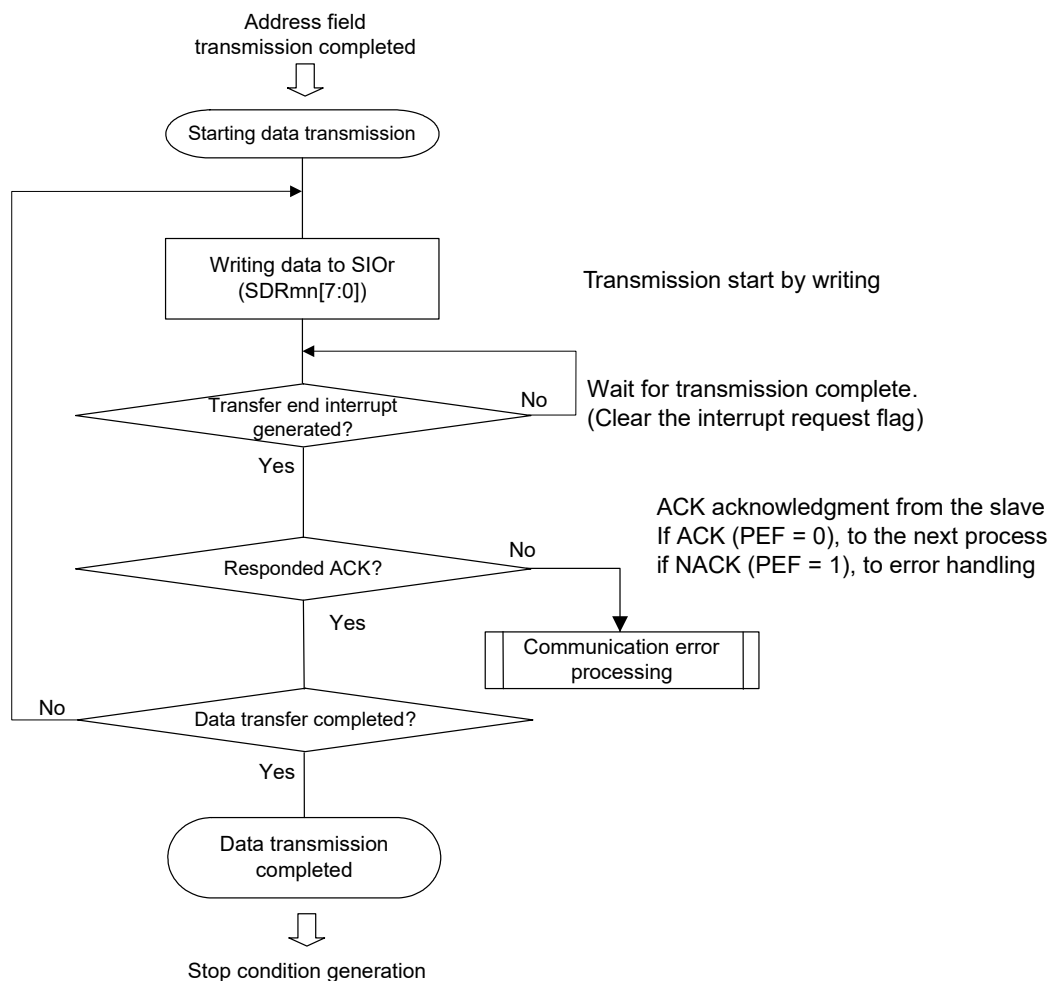

Figure 12-110. Flowchart of Simplified I²C Data Transmission



12.8.3 Data reception

Data reception is an operation to receive data to the target for transfer (slave) after transmission of an address field. After all data are received to the slave, a stop condition is generated and the bus is released.

Simplified I ² C	IIC00	IIC01	IIC10	IIC11	IIC20	IIC21	IIC30	IIC31
Target channel	Channel 0 of SAU0	Channel 1 of SAU0	Channel 2 of SAU0	Channel 3 of SAU0	Channel 0 of SAU1	Channel 1 of SAU1	Channel 2 of SAU1	Channel 3 of SAU1
Pins used	SCL00, SDA00 ^{Note 1}	SCL01, SDA01 ^{Note 1}	SCL10, SDA10 ^{Note 1}	SCL11, SDA11 ^{Note 1}	SCL20, SDA20 ^{Note 1}	SCL21, SDA21 ^{Note 1}	SCL30, SDA30 ^{Note 1}	SCL31, SDA31 ^{Note 1}
Interrupt	INTIIC00	INTIIC01	INTIIC10	INTIIC11	INTIIC20	INTIIC21	INTIIC30	INTIIC31
	Transfer end interrupt only (Setting the buffer empty interrupt is prohibited.)							
Error detection flag	Overrun error detection flag (OVFmn) only							
Transfer data length	8 bits							
Transfer rate ^{Note 2}	Max. $f_{MCK}/4$ [Hz] ($SDRmn[15:9] = 1$ or more) f_{MCK} : Operation clock frequency of target channel However, the following condition must be satisfied in each mode of I ² C. <ul style="list-style-type: none"> • Max. 1 MHz (fast mode plus) • Max. 400 kHz (fast mode) • Max. 100 kHz (standard mode) 							
Data level	Non-reversed output (default: high level)							
Parity bit	No parity bit							
Stop bit	Appending 1 bit (ACK transmission)							
Data direction	MSB first							

Notes 1. To perform communication via simplified I²C, set the N-ch open-drain output (V_{DD} tolerance (20 to 52-pin products)/ EV_{DD} tolerance (64 to 128-pin products)) mode (POMxx = 1) with the port output mode register (POMxx). For details, see **4.3 Registers Controlling Port Function** and **4.5 Register Settings When Using Alternate Function**.

When IIC00, IIC10, IIC20, IIC30, IIC31 is communicating with an external device with a different potential, set the N-ch open-drain output (V_{DD} tolerance (20 to 52-pin products)/ EV_{DD} tolerance (64 to 128-pin products)) mode (POMxx = 1) also for the clock input/output pins (SCL00, SCL10, SCL20, SCL30, SCL31). For details, see **4.4.5 Handling different potential (1.8 V, 2.5 V, 3 V) by using I/O buffers**.

2. Use this operation within a range that satisfies the conditions above and the peripheral functions characteristics in the electrical specifications (see **CHAPTER 29 ELECTRICAL SPECIFICATIONS (T_A = -40 to +85°C)** and **CHAPTER 30 ELECTRICAL SPECIFICATIONS (G: INDUSTRIAL APPLICATIONS T_A = -40 to +105°C)**).

Remark m: Unit number (m = 0, 1), n: Channel number (n = 0 to 3), mn = 00 to 03, 10 to 13

(1) Register setting

Figure 12-111. Example of Contents of Registers for Data Reception of Simplified I²C (IIC00, IIC01, IIC10, IIC11, IIC20, IIC21, IIC30, IIC31)

(a) Serial mode register mn (SMRmn) ... Do not manipulate this register during data transmission/reception.

	15	14	13	12	11	10	9	8	7	6	5	4	3	2	1	0
SMRmn	CKSmn	CCSmn						STSmn		SISmn0				MDmn2	MDmn1	MDmn0
	0/1	0	0	0	0	0	0	0	0	0	1	0	0	1	0	0
								Note 1		Note 1						

(b) Serial communication operation setting register mn (SCRmn) ... Do not manipulate the bits of this register, except the TXEmn and RXEmn bits, during data transmission/reception.

	15	14	13	12	11	10	9	8	7	6	5	4	3	2	1	0
SCRmn	TXEmn	RXEmn	DAPmn	CKPmn		EOCmn	PTCmn1	PTCmn0	DIRmn		SLCmn1	SLCmn0			DLSmn1	DLSmn0
	0	1	0	0	0	0	0	0	0	0	0	1	0	1	1	1
											Note 2				Note 3	

(c) Serial data register mn (SDRmn) (lower 8 bits: SIO_r)

	15	14	13	12	11	10	9	8	7	6	5	4	3	2	1	0	
SDRmn	Baud rate setting ^{Note 4}								0	Dummy transmit data setting (FFH)							
	SIO _r																

(d) Serial output register m (SOM_m) ... Do not manipulate this register during data transmission/reception.

	15	14	13	12	11	10	9	8	7	6	5	4	3	2	1	0
SOM _m					CKOm3	CKOm2	CKOm1	CKOm0					SOM3	SOM2	SOM1	SOM0
	0	0	0	0	0/1	0/1	0/1	0/1	0	0	0	0	0/1	0/1	0/1	0/1
					Note 5	Note 5	Note 5	Note 5					Note 5	Note 5	Note 5	Note 5

(e) Serial output enable register m (SOEm_m) ... Do not manipulate this register during data transmission/reception.

	15	14	13	12	11	10	9	8	7	6	5	4	3	2	1	0
SOEm _m													SOEm3	SOEm2	SOEm1	SOEm0
	0	0	0	0	0	0	0	0	0	0	0	0	0/1	0/1	0/1	0/1

(f) Serial channel start register m (SSm_m) ... Do not manipulate this register during data transmission/reception.

	15	14	13	12	11	10	9	8	7	6	5	4	3	2	1	0
SSm _m													SSm3	SSm2	SSm1	SSm0
	0	0	0	0	0	0	0	0	0	0	0	0	0/1	0/1	0/1	0/1

(Notes and Remarks are listed on the next page.)

- Notes**
1. Only provided for the SMR01, SMR03, SMR11, and SMR13 registers.
 2. Only provided for the SCR00, SCR02, SCR10, and SCR12 registers.
 3. Only provided for the SCR00 and SCR01 registers and the SCR10 and SCR11 registers of an 80- to 128-pin product. This bit is fixed to 1 for the other registers.
 4. Because the setting is completed by address field transmission, setting is not required.
 5. The value varies depending on the communication data during communication operation.

- Remarks**
1. m: Unit number (m = 0, 1), n: Channel number (n = 0 to 3), r: IIC number (r = 00, 01, 10, 11, 20, 21, 30, 31), mn = 00 to 03, 10 to 13
 2. : Setting is fixed in the IIC mode, : Setting disabled (set to the initial value)
0/1: Set to 0 or 1 depending on the usage of the user

(2) Processing flow

Figure 12-112. Timing Chart of Data Reception

(a) When starting data reception

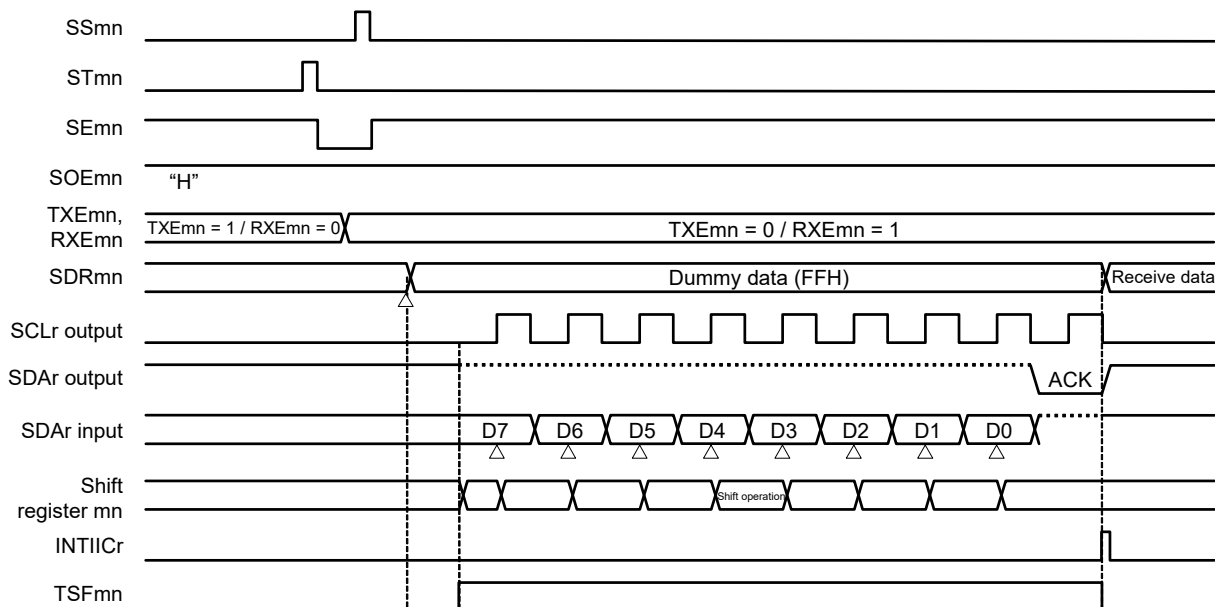

(b) When receiving last data

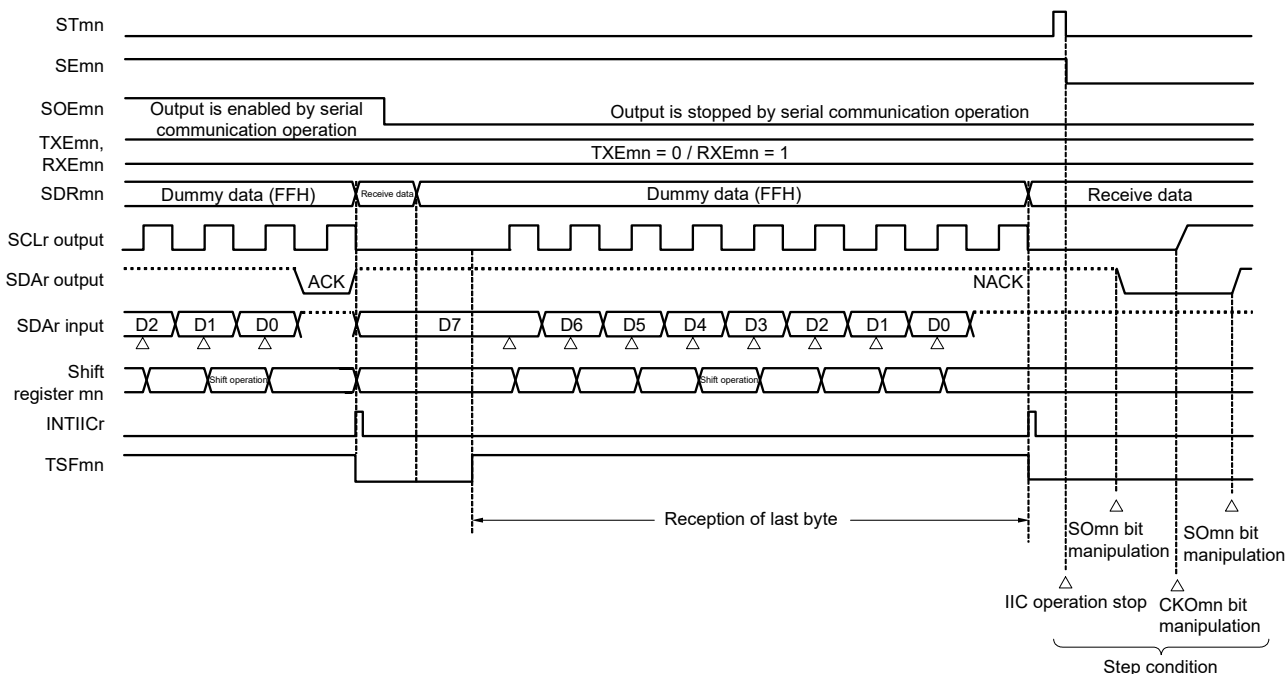

Remark m: Unit number (m = 0, 1), n: Channel number (n = 0 to 3), r: IIC number (r = 00, 01, 10, 11, 20, 21, 30, 31), mn = 00 to 03, 10 to 13

Figure 12-113. Flowchart of Data Reception

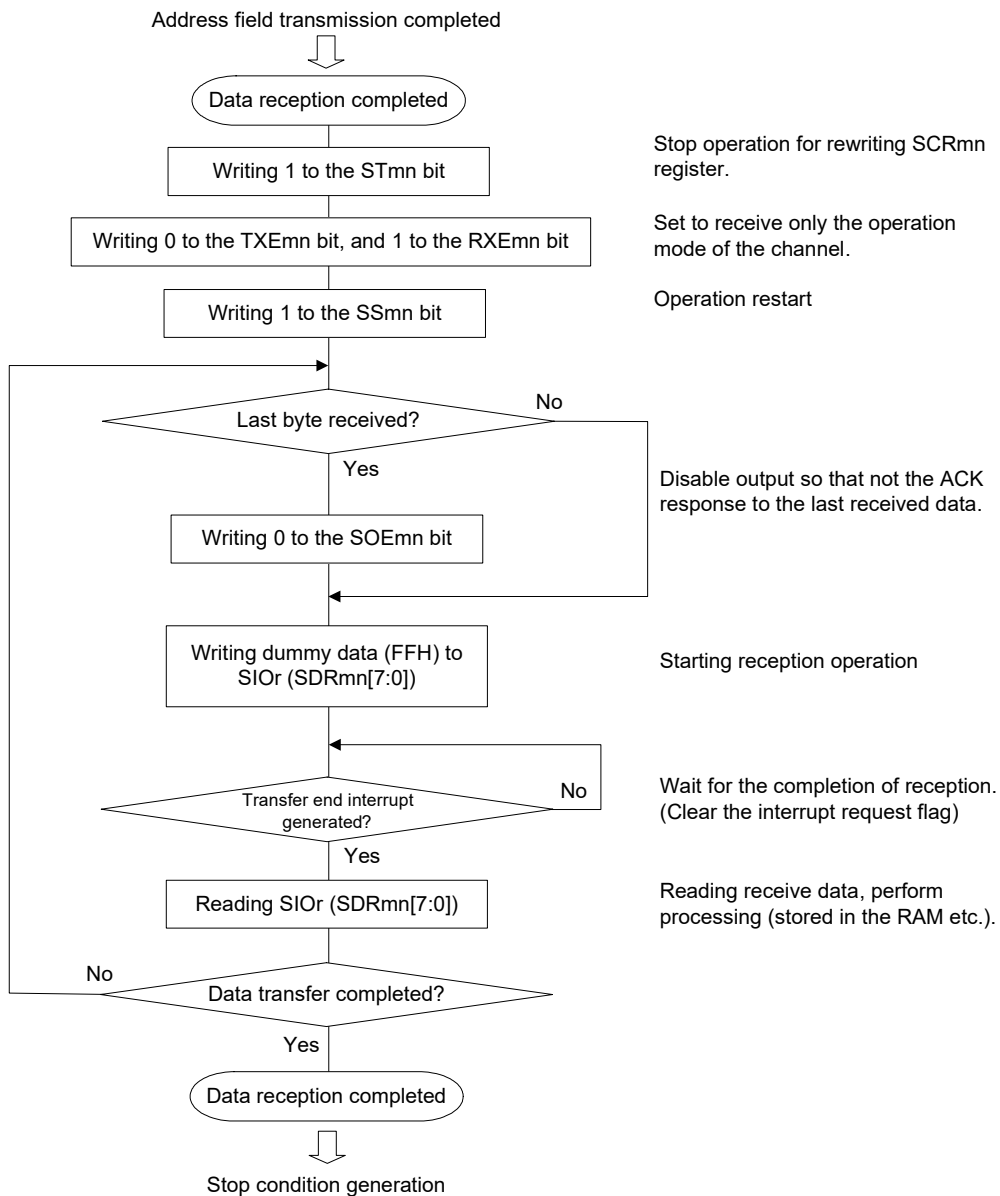

Caution ACK is not output when the last data is received (NACK). Communication is then completed by setting “1” to the STmn bit of serial channel stop register m (STm) to stop operation and generating a stop condition.

12.8.4 Stop condition generation

After all data are transmitted to or received from the target slave, a stop condition is generated and the bus is released.

(1) Processing flow

Figure 12-114. Timing Chart of Stop Condition Generation

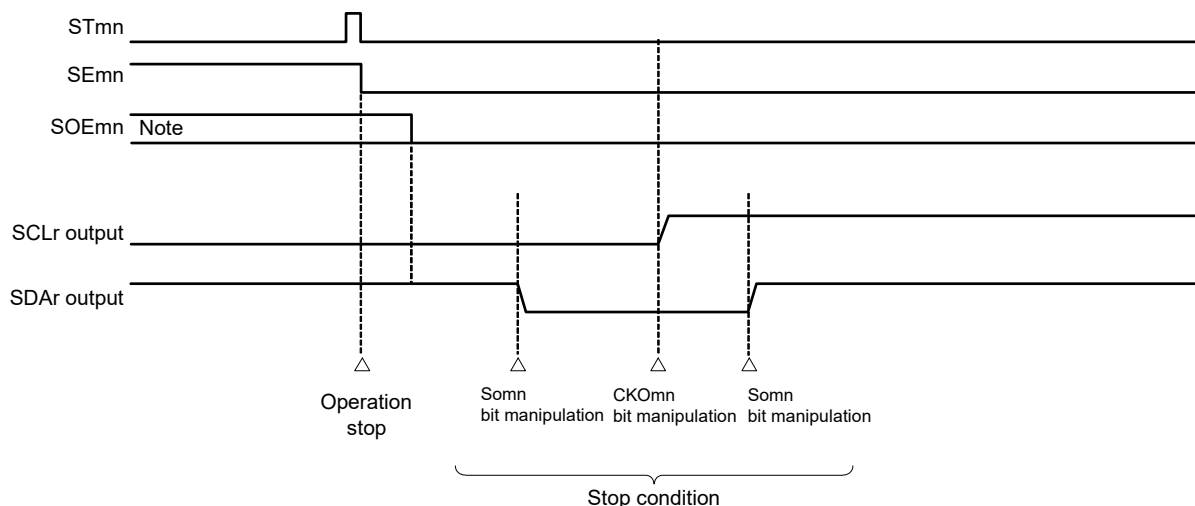

Note During a receive operation, the SOEmn bit of serial output enable register m (SOEm) is cleared to 0 before receiving the last data.

Figure 12-115. Flowchart of Stop Condition Generation

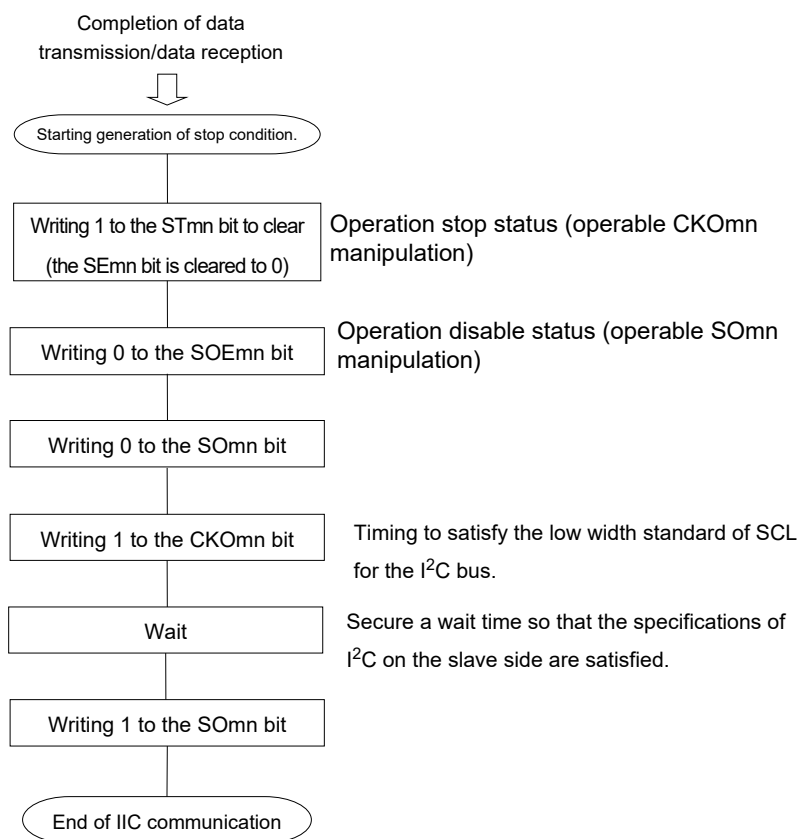

12.8.5 Calculating transfer rate

The transfer rate for simplified I²C (IIC00, IIC01, IIC10, IIC11, IIC20, IIC21, IIC30, IIC31) communication can be calculated by the following expressions.

$$(\text{Transfer rate}) = \{\text{Operation clock (f}_{\text{MCK}}) \text{ frequency of target channel}\} \div (\text{SDRmn}[15:9] + 1) \div 2$$

Caution SDRmn[15:9] must not be set to 0000000B. Be sure to set a value of 0000001B or greater for SDRmn[15:9]. The duty ratio of the SCL signal output by the simplified I²C is 50%. The I²C bus specifications define that the low-level width of the SCL signal is longer than the high-level width. If 400 kbps (fast mode) or 1 Mbps (fast mode plus) is specified, therefore, the low-level width of the SCL output signal becomes shorter than the value specified in the I²C bus specifications. Make sure that the SDRmn[15:9] value satisfies the I²C bus specifications.

- Remarks**
1. The value of SDRmn[15:9] is the value of bits 15 to 9 of the SDRmn register (0000001B to 1111111B) and therefore is 1 to 127.
 2. m: Unit number (m = 0, 1), n: Channel number (n = 0 to 3), mn = 00 to 03, 10 to 13

The operation clock (f_{MCK}) is determined by serial clock select register m (SPSm) and bit 15 (CKSmn) of serial mode register mn (SMRmn).

Table 12-5. Selection of Operation Clock For Simplified I²C

SMRmn Register	SPSm Register								Operation Clock (f _{MCK}) ^{Note}	
	CKSmn	PRS m13	PRS m12	PRS m11	PRS m10	PRS m03	PRS m02	PRS m01	PRS m00	f _{CLK} = 32 MHz
0	X	X	X	X	0	0	0	0	f _{CLK}	32 MHz
	X	X	X	X	0	0	0	1	f _{CLK} /2	16 MHz
	X	X	X	X	0	0	1	0	f _{CLK} /2 ²	8 MHz
	X	X	X	X	0	0	1	1	f _{CLK} /2 ³	4 MHz
	X	X	X	X	0	1	0	0	f _{CLK} /2 ⁴	2 MHz
	X	X	X	X	0	1	0	1	f _{CLK} /2 ⁵	1 MHz
	X	X	X	X	0	1	1	0	f _{CLK} /2 ⁶	500 kHz
	X	X	X	X	0	1	1	1	f _{CLK} /2 ⁷	250 kHz
	X	X	X	X	1	0	0	0	f _{CLK} /2 ⁸	125 kHz
	X	X	X	X	1	0	0	1	f _{CLK} /2 ⁹	62.5 kHz
	X	X	X	X	1	0	1	0	f _{CLK} /2 ¹⁰	31.25 kHz
X	X	X	X	1	0	1	1	f _{CLK} /2 ¹¹	15.63 kHz	
1	0	0	0	0	X	X	X	X	f _{CLK}	32 MHz
	0	0	0	1	X	X	X	X	f _{CLK} /2	16 MHz
	0	0	1	0	X	X	X	X	f _{CLK} /2 ²	8 MHz
	0	0	1	1	X	X	X	X	f _{CLK} /2 ³	4 MHz
	0	1	0	0	X	X	X	X	f _{CLK} /2 ⁴	2 MHz
	0	1	0	1	X	X	X	X	f _{CLK} /2 ⁵	1 MHz
	0	1	1	0	X	X	X	X	f _{CLK} /2 ⁶	500 kHz
	0	1	1	1	X	X	X	X	f _{CLK} /2 ⁷	250 kHz
	1	0	0	0	X	X	X	X	f _{CLK} /2 ⁸	125 kHz
	1	0	0	1	X	X	X	X	f _{CLK} /2 ⁹	62.5 kHz
	1	0	1	0	X	X	X	X	f _{CLK} /2 ¹⁰	31.25 kHz
1	0	1	1	X	X	X	X	f _{CLK} /2 ¹¹	15.63 kHz	
Other than above									Setting prohibited	

Note When changing the clock selected for f_{CLK} (by changing the system clock control register (CKC) value), do so after having stopped (serial channel stop register m (STm) = 000FH) the operation of the serial array unit (SAU).

Remarks 1. X: Don't care

2. m: Unit number (m = 0, 1), n: Channel number (n = 0 to 3), mn = 00 to 03, 10 to 13

Here is an example of setting an I²C transfer rate where f_{MCK} = f_{CLK} = 32 MHz.

I ² C Transfer Mode (Desired Transfer Rate)	f _{CLK} = 32 MHz			
	Operation Clock (f _{MCK})	SDRmn[15:9]	Calculated Transfer Rate	Error from Desired Transfer Rate
100 kHz	f _{CLK} /2	79	100 kHz	0.0%
400 kHz	f _{CLK}	41	380 kHz	5.0% ^{Note}
1 MHz	f _{CLK}	18	0.84 MHz	16.0% ^{Note}

Note The error cannot be set to about 0% because the duty ratio of the SCL signal is 50%.

12.8.6 Procedure for processing errors that occurred during simplified I²C (IIC00, IIC01, IIC10, IIC11, IIC20, IIC21, IIC30, IIC31) communication

The procedure for processing errors that occurred during simplified I²C (IIC00, IIC01, IIC10, IIC11, IIC20, IIC21, IIC30, IIC31) communication is described in **Figures 12-116** and **12-117**.

Figure 12-116. Processing Procedure in Case of Overrun Error

Software Manipulation	Hardware Status	Remark
Reads serial data register mn (SDRmn). →	The BFFmn bit of the SSRmn register is set to 0 and channel n is enabled to receive data.	This is to prevent an overrun error if the next reception is completed during error processing.
Reads serial status register mn (SSRmn).		The error type is identified and the read value is used to clear the error flag.
Writes 1 to serial flag clear trigger register mn (SIRmn). →	The error flag is cleared.	The error only during reading can be cleared, by writing the value read from the SSRmn register to the SIRmn register without modification.

Figure 12-117. Processing Procedure in Case of ACK Error in Simplified I²C Mode

Software Manipulation	Hardware Status	Remark
Reads serial status register mn (SSRmn).		The error type is identified and the read value is used to clear the error flag.
Writes 1 to serial flag clear trigger register mn (SIRmn). →	The error flag is cleared.	The error only during reading can be cleared, by writing the value read from the SSRmn register to the SIRmn register without modification.
Sets the STmn bit of serial channel stop register m (STm) to 1. →	The SEMn bit of serial channel enable status register m (SEm) is set to 0 and channel n stops operation.	The slave is not ready for reception because ACK is not returned. Therefore, a stop condition is created, the bus is released, and communication is started again from the start condition. Or, a restart condition is generated and transmission can be redone from address transmission.
Creates a stop condition.		
Creates a start condition.		
Sets the SSmn bit of serial channel start register m (SSm) to 1. →	The SEMn bit of serial channel enable status register m (SEm) is set to 1 and channel n is enabled to operate.	

Remark m: Unit number (m = 0, 1), n: Channel number (n = 0 to 3), r: IIC number (r = 00, 01, 10, 11, 20, 21, 30, 31)
mn = 00 to 03, 10 to 13

CHAPTER 13 SERIAL INTERFACE IICA

The number of channels of the serial Interface IICA differs, depending on the product.

	20-pin	24, 25, 30, 32, 36, 40, 44, 48, 52, 56, 64-pin	80, 100, 128-pin
channels	–	1 ch	2 ch

Caution Most of the following descriptions in this chapter use the 64-pin products as an example.

13.1 Functions of Serial Interface IICA

Serial interface IICA has the following three modes.

(1) Operation stop mode

This mode is used when serial transfers are not performed. It can therefore be used to reduce power consumption.

(2) I²C bus mode (multimaster supported)

This mode is used for 8-bit data transfers with several devices via two lines: a serial clock (SCLAn) line and a serial data bus (SDAAn) line.

This mode complies with the I²C bus format and the master device can generate “start condition”, “address”, “transfer direction specification”, “data”, and “stop condition” data to the slave device, via the serial data bus. The slave device automatically detects these received status and data by hardware. This function can simplify the part of application program that controls the I²C bus.

Since the SCLAn and SDAAn pins are used for open drain outputs, serial interface IICA requires pull-up resistors for the serial clock line and the serial data bus line.

(3) Wakeup mode

The STOP mode can be released by generating an interrupt request signal (INTIICAn) when an extension code from the master device or a local address has been received while in STOP mode. This can be set by using the WUPn bit of IICA control register n1 (IICCTLn1).

Figure 13-1 shows a block diagram of serial interface IICA.

Remark n = 0, 1

Figure 13-1. Block Diagram of Serial Interface IICA0

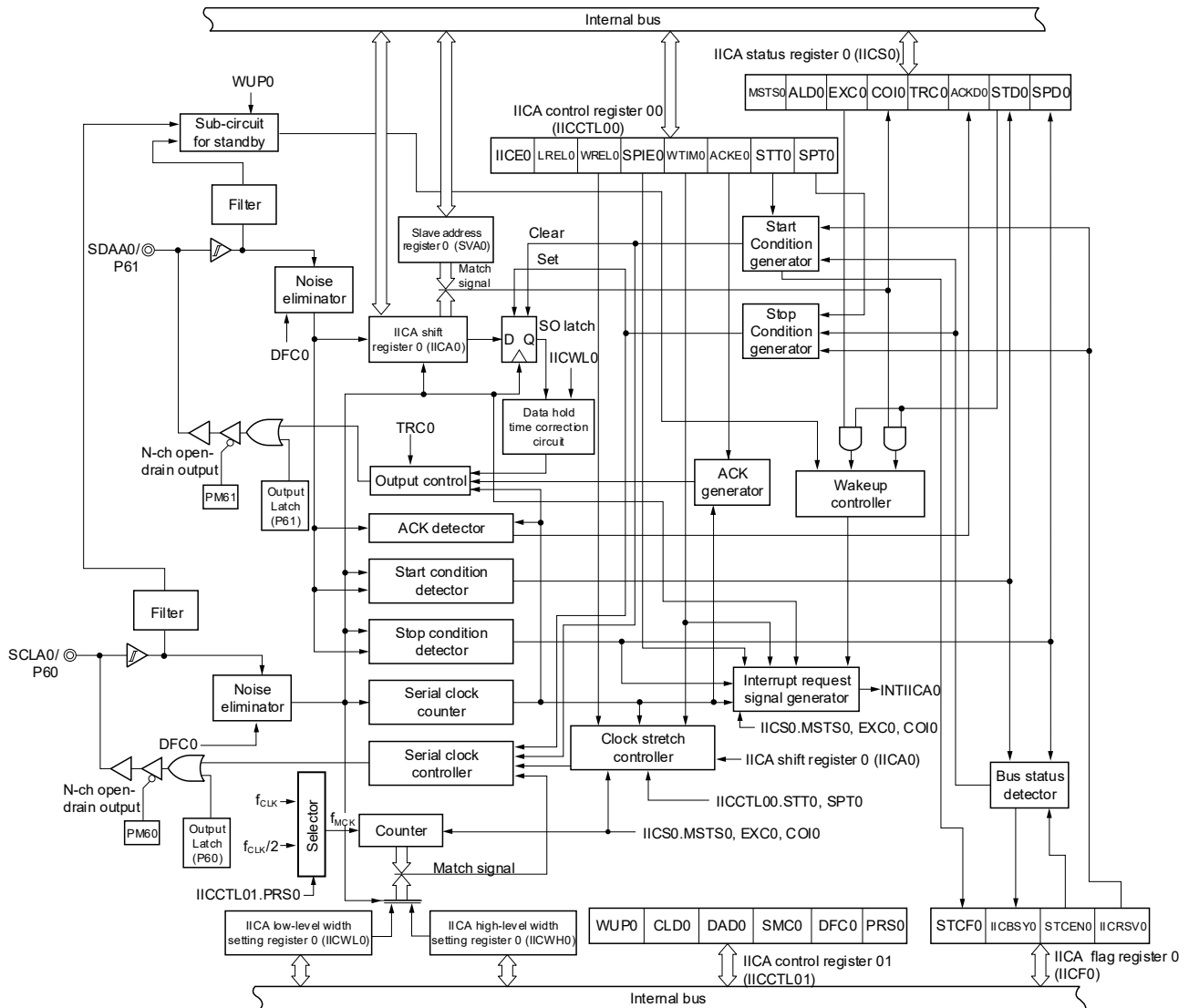
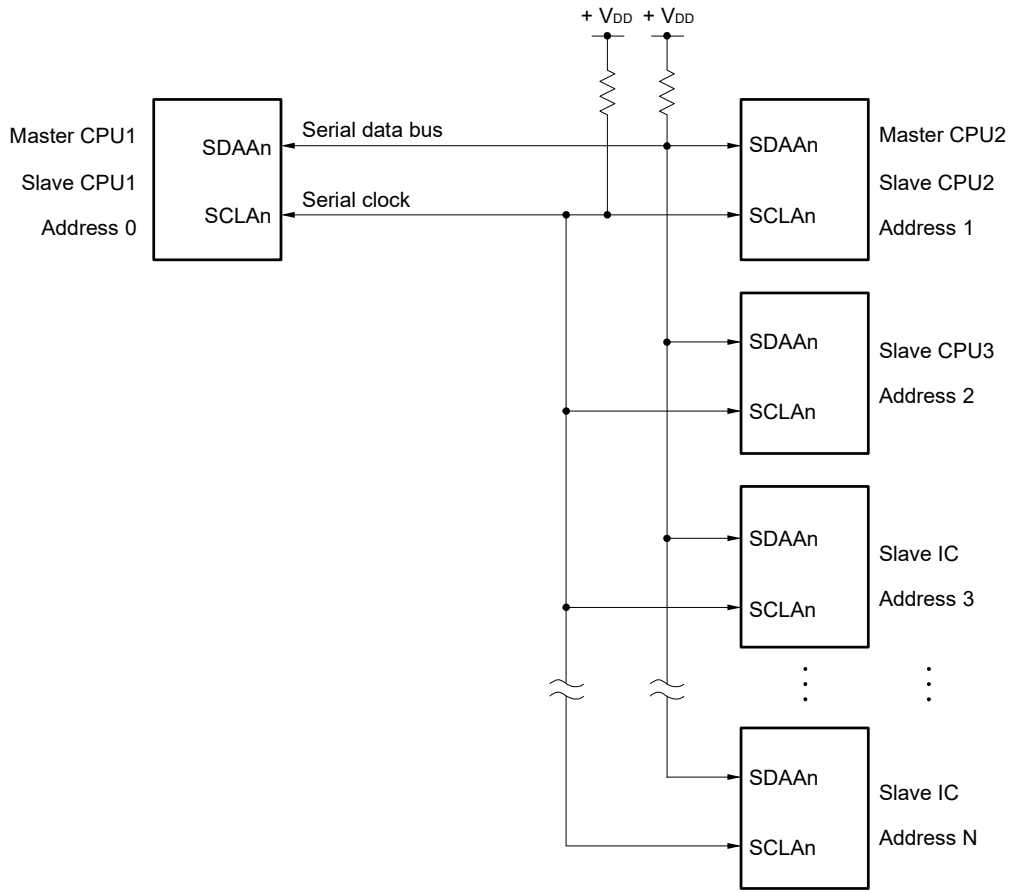

Figure 13-2 shows a serial bus configuration example.

Figure 13-2. Serial Bus Configuration Example Using I²C Bus



Remark n = 0, 1

13.2 Configuration of Serial Interface IICA

Serial interface IICA includes the following hardware.

Table 13-1. Configuration of Serial Interface IICA

Item	Configuration
Registers	IICA shift register n (IICAn) Slave address register n (SVAn)
Control registers	Peripheral enable register 0 (PER0) IICA control register n0 (IICCTLn0) IICA status register n (IICSn) IICA flag register n (IICFn) IICA control register n1 (IICCTLn1) IICA low-level width setting register n (IICWLn) IICA high-level width setting register n (IICWHn) Port mode register 6 (PM6) Port register 6 (P6)

(1) IICA shift register n (IICAn)

The IICAn register is used to convert 8-bit serial data to 8-bit parallel data and vice versa in synchronization with the serial clock. The IICAn register can be used for both transmission and reception.

The actual transmit and receive operations can be controlled by writing and reading operations to the IICAn register. Cancel the clock stretch state and start data transfer by writing data to the IICAn register during the clock stretch period.

The IICAn register can be set by an 8-bit memory manipulation instruction.

Reset signal generation clears IICAn to 00H.

Figure 13-3. Format of IICA Shift Register n (IICAn)

Address: FFF50H (IICA0), FFF54H (IICA1) After reset: 00H R/W

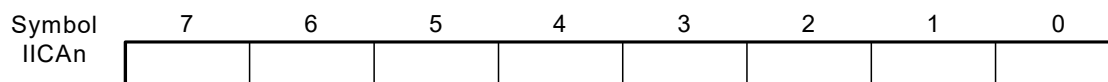

- Cautions**
1. Do not write data to the IICAn register during data transfer.
 2. Write or read the IICAn register only during the clock stretch period. Accessing the IICAn register in a communication state other than during the clock stretch period is prohibited. When the device serves as the master, however, the IICAn register can be written only once after the communication trigger bit (STTn) is set to 1.
 3. When communication is reserved, write data to the IICAn register after the interrupt triggered by a stop condition is detected.

Remark n = 0, 1

(2) Slave address register n (SVAn)

This register stores seven bits of local addresses {A6, A5, A4, A3, A2, A1, A0} when in slave mode. The SVAn register can be set by an 8-bit memory manipulation instruction. However, rewriting to this register is prohibited while STDn = 1 (while the start condition is detected). Reset signal generation clears the SVAn register to 00H.

Figure 13-4. Format of Slave Address Register n (SVAn)

Address: F0234H (SVA0), F023CH (SVA1) After reset: 00H R/W

Symbol SVAn	7	6	5	4	3	2	1	0
	A6	A5	A4	A3	A2	A1	A0	0 ^{Note}

Note Bit 0 is fixed to 0.

(3) SO latch

The SO latch is used to retain the SDAAn pin's output level.

(4) Wakeup controller

This circuit generates an interrupt request (INTIICAn) when the address received by this register matches the address value set to the slave address register n (SVAn) or when an extension code is received.

(5) Serial clock counter

This counter counts the serial clocks that are output or input during transmit/receive operations and is used to verify that 8-bit data was transmitted or received.

(6) Interrupt request signal generator

This circuit controls the generation of interrupt request signals (INTIICAn). An I²C interrupt request is generated by the following two triggers.

- Falling edge of eighth or ninth clock of the serial clock (set by the WTIMn bit)
- Interrupt request generated when a stop condition is detected (set by the SPIEn bit)

Remark WTIMn bit: Bit 3 of IICA control register n0 (IICCTLn0)

SPIEn bit: Bit 4 of IICA control register n0 (IICCTLn0)

(7) Serial clock controller

In master mode, this circuit generates the clock output via the SCLAn pin from a sampling clock.

(8) Clock stretch controller

This circuit controls the timing of clock stretching.

(9) ACK generator, stop condition detector, start condition detector, and ACK detector

These circuits generate and detect each status.

(10) Data hold time correction circuit

This circuit generates the hold time for data corresponding to the falling edge of the serial clock.

Remark n = 0, 1

(11) Start condition generator

This circuit generates a start condition when the STTn bit is set to 1.

However, in the communication reservation disabled status (IICRSVn bit = 1), when the bus is not released (IICBSYn bit = 1), start condition requests are ignored and the STCFn bit is set to 1.

(12) Stop condition generator

This circuit generates a stop condition when the SPTn bit is set to 1.

(13) Bus status detector

This circuit detects whether or not the bus is released by detecting start conditions and stop conditions.

However, as the bus status cannot be detected immediately following operation, the initial status is set by the STCENn bit.

- Remarks 1.**
- | | |
|--------------|--|
| STTn bit: | Bit 1 of IICA control register n0 (IICCTLn0) |
| SPTn bit: | Bit 0 of IICA control register n0 (IICCTLn0) |
| IICRSVn bit: | Bit 0 of IICA flag register n (IICFn) |
| IICBSYn bit: | Bit 6 of IICA flag register n (IICFn) |
| STCFn bit: | Bit 7 of IICA flag register n (IICFn) |
| STCENn bit: | Bit 1 of IICA flag register n (IICFn) |
- 2.** n = 0, 1

13.3 Registers Controlling Serial Interface IICA

Serial interface IICA is controlled by the following registers.

- Peripheral enable register 0 (PER0)
- IICA control register n0 (IICCTLn0)
- IICA flag register n (IICFn)
- IICA status register n (IICSn)
- IICA control register n1 (IICCTLn1)
- IICA low-level width setting register n (IICWLn)
- IICA high-level width setting register n (IICWHn)
- Port mode register 6 (PM6)
- Port register 6 (P6)

13.3.1 Peripheral enable register 0 (PER0)

This register is used to enable or disable supplying the clock to the peripheral hardware. Clock supply to a hardware macro that is not used is stopped in order to reduce the power consumption and noise.

When serial interface IICAn is used, be sure to set bits 6, 4 (IICA1EN, IICA0EN) of this register to 1.

The PER0 register can be set by a 1-bit or 8-bit memory manipulation instruction.

Reset signal generation clears this register to 00H.

Figure 13-5. Format of Peripheral Enable Register 0 (PER0)

Address: F00F0H After reset: 00H R/W

Symbol	<7>	<6>	<5>	<4>	<3>	<2>	<1>	<0>
PER0	RTCEN ^{Note 1}	IICA1EN ^{Note 1}	ADCEN	IICA0EN ^{Note 2}	SAU1EN ^{Note 3}	SAU0EN	TAU1EN ^{Note 1}	TAU0EN

IICAnEN	Control of serial interface IICAn input clock supply
0	Stops input clock supply. <ul style="list-style-type: none"> • SFR used by serial interface IICAn cannot be written. • Serial interface IICAn is in the reset status.
1	Enables input clock supply. <ul style="list-style-type: none"> • SFR used by serial interface IICAn can be read/written.

- Notes**
1. 80, 100, and 128-pin products only.
 2. This is not provided in the 20-pin products.
 3. This is not provided in the 20, 24, and 25-pin products.

Cautions

1. When setting serial interface IICA, be sure to set the following registers first while the IICAnEN bit is set to 1. If IICAnEN = 0, the control registers of serial interface IICA are set to their initial values, and writing to them is ignored (except for port mode register 6 (PM6) and port register 6 (P6)).

- IICA control register n0 (IICCTLn0)
- IICA flag register n (IICFn)
- IICA status register n (IICSn)
- IICA control register n1 (IICCTLn1)
- IICA low-level width setting register n (IICWLn)
- IICA high-level width setting register n (IICWHn)

2. Be sure to clear the following bits to 0.

20-pin products: bits 1, 3, 4, 6

24, 25-pin products: bits 1, 3, 6

30, 32, 36, 40, 44, 48, 52, 64-pin products: bits 1, 6

Remark n = 0, 1

13.3.2 IICA control register n0 (IICCTLn0)

This register is used to enable/stop I²C operations, set clock stretch timing, and set other I²C operations.

The IICCTLn0 register can be set by a 1-bit or 8-bit memory manipulation instruction. However, set the SPIEn, WTIMn, and ACKEn bits while IICEn = 0 or during the clock stretch period. These bits can be set at the same time when the IICEn bit is set from “0” to “1”.

Reset signal generation clears this register to 00H.

Remark n = 0, 1

Figure 13-6. Format of IICA Control Register n0 (IICCTLn0) (1/4)

Address: F0230H (IICCTL00), F0238H (IICCTL10) After reset: 00H R/W

Symbol	<7>	<6>	<5>	<4>	<3>	<2>	<1>	<0>
IICCTLn0	IICEn	LRELn	WRELn	SPIEn	WTIMn	ACKEn	STTn	SPTn
IICEn	I ² C operation enable							
0	Stop operation. Reset the IICA status register n (IICSn) ^{Note 1} . Stop internal operation.							
1	Enable operation.							
Be sure to set this bit (1) while the SCLAn and SDAAn lines are at high level.								
Condition for clearing (IICEn = 0)					Condition for setting (IICEn = 1)			
<ul style="list-style-type: none"> • Cleared by instruction • Reset 					<ul style="list-style-type: none"> • Set by instruction 			
LRELn ^{Notes 2,3}	Exit from communications							
0	Normal operation							
1	This exits from the current communications and sets standby mode. This setting is automatically cleared to 0 after being executed. Its uses include cases in which a locally irrelevant extension code has been received. The SCLAn and SDAAn lines are set to high impedance. The following flags of IICA control register n0 (IICCTLn0) and the IICA status register n (IICSn) are cleared to 0. <ul style="list-style-type: none"> • STTn • SPTn • MSTSn • EXCn • COIn • TRCn • ACKDn • STDn 							
The standby mode following exit from communications remains in effect until the following communications entry conditions are met.								
<ul style="list-style-type: none"> • After a stop condition is detected, restart is in master mode. • An address match or extension code reception occurs after the start condition. 								
Condition for clearing (LRELn = 0)					Condition for setting (LRELn = 1)			
<ul style="list-style-type: none"> • Automatically cleared after execution • Reset 					<ul style="list-style-type: none"> • Set by instruction 			
WRELn ^{Notes 2,3}	Clock stretch cancellation							
0	Do not cancel clock stretch							
1	Cancel clock stretch. This setting is automatically cleared after clock stretch is canceled.							
When the WRELn bit is set (clock stretch canceled) during the clock stretch period at the ninth clock pulse in the transmission status (TRCn = 1), the SDAAn line goes into the high impedance state (TRCn = 0).								
Condition for clearing (WRELn = 0)					Condition for setting (WRELn = 1)			
<ul style="list-style-type: none"> • Automatically cleared after execution • Reset 					<ul style="list-style-type: none"> • Set by instruction 			

- Notes**
1. The IICA status register n (IICSn), the STCFn and IICBSYn bits of the IICA flag register n (IICFn), and the CLDn and DADn bits of IICA control register n1 (IICCTLn1) are reset.
 2. The signal of this bit is invalid while IICEn is 0.
 3. When the LRELn and WRELn bits are read, 0 is always read.

Caution If the operation of I²C is enabled (IICEn = 1) when the SCLAn line is high level, the SDAAn line is low level, and the digital filter is turned on (DFCn bit of IICCTLn1 register = 1), a start condition will be inadvertently detected immediately. In this case, set (1) the LRELn bit by using a 1-bit memory manipulation instruction immediately after enabling operation of I²C (IICEn = 1).

Remark n = 0, 1

Figure 13-6. Format of IICA Control Register n0 (IICCTLn0) (2/4)

SPIEn ^{Note 1}	Enable/disable generation of interrupt request when stop condition is detected	
0	Disable	
1	Enable	
If the WUPn bit of IICA control register n1 (IICCTLn1) is 1, no stop condition interrupt will be generated even if SPIEn = 1.		
Condition for clearing (SPIEn = 0)		Condition for setting (SPIEn = 1)
<ul style="list-style-type: none"> • Cleared by instruction • Reset 		<ul style="list-style-type: none"> • Set by instruction

WTIMn ^{Note 1}	Control of clock stretch and interrupt request generation	
0	Interrupt request is generated at the eighth clock's falling edge. Master mode: After output of eight clocks, clock output is set to low level and clock stretch is set. Slave mode: After input of eight clocks, the clock is set to low level and clock stretch is set for master device.	
1	Interrupt request is generated at the ninth clock's falling edge. Master mode: After output of nine clocks, clock output is set to low level and clock stretch is set. Slave mode: After input of nine clocks, the clock is set to low level and clock stretch is set for master device.	
An interrupt is generated at the falling edge of the ninth clock during address transfer independently of the setting of this bit. The setting of this bit is valid when the address transfer is completed. When in master mode, a clock stretch is inserted at the falling edge of the ninth clock during address transfers. For a slave device that has received a local address, a clock stretch is inserted at the falling edge of the ninth clock after an acknowledge (ACK) is issued. However, when the slave device has received an extension code, a clock stretch is inserted at the falling edge of the eighth clock.		
Condition for clearing (WTIMn = 0)		Condition for setting (WTIMn = 1)
<ul style="list-style-type: none"> • Cleared by instruction • Reset 		<ul style="list-style-type: none"> • Set by instruction

ACKEn ^{Notes 1,2}	Acknowledgment control	
0	Disable acknowledgment.	
1	Enable acknowledgment. During the ninth clock period, the SDAAn line is set to low level.	
Condition for clearing (ACKEn = 0)		Condition for setting (ACKEn = 1)
<ul style="list-style-type: none"> • Cleared by instruction • Reset 		<ul style="list-style-type: none"> • Set by instruction

- Notes**
1. The signal of this bit is invalid while IICEn is 0. Set this bit during that period.
 2. The set value is invalid during address transfer and if the code is not an extension code.
When the device serves as a slave and the addresses match, an acknowledgment is generated regardless of the set value.

Remark n = 0, 1

Figure 13-6. Format of IICA Control Register n0 (IICCTLn0) (3/4)

STTn ^{Notes 1, 2}	Start condition trigger				
0	Do not generate a start condition.				
1	<p>When bus is released (in standby state, when IICBSYn = 0): If this bit is set (1), a start condition is generated (startup as the master).</p> <p>When a third party is communicating:</p> <ul style="list-style-type: none"> • When communication reservation function is enabled (IICRSVn = 0) Functions as the start condition reservation flag. When set to 1, automatically generates a start condition after the bus is released. • When communication reservation function is disabled (IICRSVn = 1) Even if this bit is set (1), the STTn bit is cleared and the STTn clear flag (STCFn) is set (1). No start condition is generated. <p>In the clock stretch state (when master device): Generates a restart condition after releasing the clock stretch.</p>				
<p>Cautions concerning set timing</p> <ul style="list-style-type: none"> • For master reception: Cannot be set to 1 during transfer. Can be set to 1 only in the clock stretch period when the ACKEn bit has been cleared to 0 and slave has been notified of final reception. • For master transmission: A start condition cannot be generated normally during the acknowledge period. Set to 1 during the clock stretch period that follows output of the ninth clock. • Cannot be set to 1 at the same time as stop condition trigger (SPTn). • Once STTn is set (1), setting it again (1) before the clear condition is met is not allowed. 					
<table border="1" style="width: 100%;"> <thead> <tr> <th>Condition for clearing (STTn = 0)</th> <th>Condition for setting (STTn = 1)</th> </tr> </thead> <tbody> <tr> <td> <ul style="list-style-type: none"> • Cleared by setting the STTn bit to 1 while communication reservation is prohibited. • Cleared by loss in arbitration • Cleared after start condition is generated by master device • Cleared by LRELn = 1 (exit from communications) • When IICEn = 0 (operation stop) • Reset </td> <td> <ul style="list-style-type: none"> • Set by instruction </td> </tr> </tbody> </table>		Condition for clearing (STTn = 0)	Condition for setting (STTn = 1)	<ul style="list-style-type: none"> • Cleared by setting the STTn bit to 1 while communication reservation is prohibited. • Cleared by loss in arbitration • Cleared after start condition is generated by master device • Cleared by LRELn = 1 (exit from communications) • When IICEn = 0 (operation stop) • Reset 	<ul style="list-style-type: none"> • Set by instruction
Condition for clearing (STTn = 0)	Condition for setting (STTn = 1)				
<ul style="list-style-type: none"> • Cleared by setting the STTn bit to 1 while communication reservation is prohibited. • Cleared by loss in arbitration • Cleared after start condition is generated by master device • Cleared by LRELn = 1 (exit from communications) • When IICEn = 0 (operation stop) • Reset 	<ul style="list-style-type: none"> • Set by instruction 				

- Notes**
1. The signal of this bit is invalid while IICEn is 0.
 2. The STTn bit is always read as 0.

- Remarks**
1. IICRSVn: Bit 0 of IIC flag register n (IICFn)
 STCFn: Bit 7 of IIC flag register n (IICFn)
 2. n = 0, 1

Figure 13-6. Format of IICA Control Register n0 (IICCTLn0) (4/4)

SPTn ^{Note}	Stop condition trigger	
0	Stop condition is not generated.	
1	Stop condition is generated (termination of master device's transfer).	
<p>Cautions concerning set timing</p> <ul style="list-style-type: none"> For master reception: Cannot be set to 1 during transfer. Can be set to 1 only in the clock stretch period when the ACKEn bit has been cleared to 0 and slave has been notified of final reception. For master transmission: A stop condition cannot be generated normally during the acknowledge period. Therefore, set it during the clock stretch period that follows output of the ninth clock. Cannot be set to 1 at the same time as start condition trigger (STTn). The SPTn bit can be set to 1 only when in master mode. When the WTIMn bit has been cleared to 0, if the SPTn bit is set to 1 during the clock stretch period that follows output of eight clocks, note that a stop condition will be generated during the high-level period of the ninth clock. The WTIMn bit should be changed from 0 to 1 during the clock stretch period following the output of eight clocks, and the SPTn bit should be set to 1 during the clock stretch period that follows the output of the ninth clock. Once SPTn is set (1), setting it again (1) before the clear condition is met is not allowed. 		
Condition for clearing (SPTn = 0)		Condition for setting (SPTn = 1)
<ul style="list-style-type: none"> Cleared by loss in arbitration Automatically cleared after stop condition is detected Cleared by LRELn = 1 (exit from communications) When IICEn = 0 (operation stop) Reset 		<ul style="list-style-type: none"> Set by instruction

Note When the SPTn register is read, 0 is always read.

Caution When bit 3 (TRCn) of the IICA status register n (IICSn) is set to 1 (transmission status), bit 5 (WRELn) of IICA control register n0 (IICCTLn0) is set to 1 during the ninth clock and clock stretch is canceled, after which the TRCn bit is cleared (reception status) and the SDAAn line is set to high impedance. Release the clock stretch performed while the TRCn bit is 1 (transmission status) by writing to the IICA shift register n.

Remarks 1. Bit 0 (SPTn) becomes 0 when it is read after data setting.
2. n = 0, 1

13.3.3 IICA status register n (IICSn)

This register indicates the status of I²C.

The IICSn register is read by a 1-bit or 8-bit memory manipulation instruction only when STTn = 1 and during the clock stretch period.

Reset signal generation clears this register to 00H.

Caution Reading the IICSn register while the address match wakeup function is enabled (WUPn = 1) in STOP mode is prohibited. When the WUPn bit is changed from 1 to 0 (wakeup operation is stopped), regardless of the INTIICAn interrupt request, the change in status is not reflected until the next start condition or stop condition is detected. To use the wakeup function, therefore, enable (SPIEn = 1) the interrupt generated by detecting a stop condition and read the IICSn register after the interrupt has been detected.

Remark STTn: bit 1 of IICA control register n0 (IICCTLn0)
 WUPn: bit 7 of IICA control register n1 (IICCTLn1)

Figure 13-7. Format of IICA Status Register n (IICSn) (1/3)

Address: FFF51H (IICS0), FFF55H (IICS1) After reset: 00H R

Symbol	<7>	<6>	<5>	<4>	<3>	<2>	<1>	<0>
IICSn	MSTS _n	ALD _n	EXC _n	COIn	TRC _n	ACKD _n	STD _n	SPD _n

MSTS _n	Master status check flag
0	Slave device status or communication standby status
1	Master device communication status
Condition for clearing (MSTS _n = 0)	
<ul style="list-style-type: none"> When a stop condition is detected When ALD_n = 1 (arbitration loss) Cleared by LREL_n = 1 (exit from communications) When the IICEn bit changes from 1 to 0 (operation stop) Reset 	
Condition for setting (MSTS _n = 1)	
<ul style="list-style-type: none"> When a start condition is generated 	

ALD _n	Detection of arbitration loss
0	This status means either that there was no arbitration or that the arbitration result was a "win".
1	This status indicates the arbitration result was a "loss". The MSTS _n bit is cleared.
Condition for clearing (ALD _n = 0)	
<ul style="list-style-type: none"> Automatically cleared after the IICSn register is read^{Note} When the IICEn bit changes from 1 to 0 (operation stop) Reset 	
Condition for setting (ALD _n = 1)	
<ul style="list-style-type: none"> When the arbitration result is a "loss". 	

Note This register is also cleared when a 1-bit memory manipulation instruction is executed for bits other than the IICSn register. Therefore, when using the ALD_n bit, read the data of this bit before the data of the other bits.

Remarks 1. LREL_n: Bit 6 of IICA control register n0 (IICCTLn0)
 IICEn: Bit 7 of IICA control register n0 (IICCTLn0)
 2. n = 0, 1

Figure 13-7. Format of IICA Status Register n (IICSn) (2/3)

EXCn	Detection of extension code reception	
0	Extension code was not received.	
1	Extension code was received.	
Condition for clearing (EXCn = 0)		Condition for setting (EXCn = 1)
<ul style="list-style-type: none"> When a start condition is detected When a stop condition is detected Cleared by LRELn = 1 (exit from communications) When the IICEn bit changes from 1 to 0 (operation stop) Reset 		<ul style="list-style-type: none"> When the higher four bits of the received address data is either "0000" or "1111" (set at the rising edge of the eighth clock).

COIn	Detection of matching addresses	
0	Addresses do not match.	
1	Addresses match.	
Condition for clearing (COIn = 0)		Condition for setting (COIn = 1)
<ul style="list-style-type: none"> When a start condition is detected When a stop condition is detected Cleared by LRELn = 1 (exit from communications) When the IICEn bit changes from 1 to 0 (operation stop) Reset 		<ul style="list-style-type: none"> When the received address matches the local address (slave address register n (SVAn)) (set at the rising edge of the eighth clock).

TRCn	Detection of transmit/receive status	
0	Receive status (other than transmit status). The SDAAn line is set for high impedance.	
1	Transmit status. The value in the SOn latch is enabled for output to the SDAAn line (valid starting at the falling edge of the first byte's ninth clock).	
Condition for clearing (TRCn = 0)		Condition for setting (TRCn = 1)
<p><Both master and slave></p> <ul style="list-style-type: none"> When a stop condition is detected Cleared by LRELn = 1 (exit from communications) When the IICEn bit changes from 1 to 0 (operation stop) Cleared by WRELn = 1^{Note} (clock stretch cancel) When the ALDn bit changes from 0 to 1 (arbitration loss) Reset When not used for communication (MSTSn, EXCn, COIn = 0) <p><Master></p> <ul style="list-style-type: none"> When "1" is output to the first byte's LSB (transfer direction specification bit) <p><Slave></p> <ul style="list-style-type: none"> When a start condition is detected When "0" is input to the first byte's LSB (transfer direction specification bit) 		<p><Master></p> <ul style="list-style-type: none"> When a start condition is generated When 0 (master transmission) is output to the LSB (transfer direction specification bit) of the first byte (during address transfer) <p><Slave></p> <ul style="list-style-type: none"> When 1 (slave transmission) is input to the LSB (transfer direction specification bit) of the first byte from the master (during address transfer)

Note When bit 3 (TRCn) of the IICA status register n (IICSn) is set to 1 (transmission status), bit 5 (WRELn) of IICA control register n0 (IICCTLn0) is set to 1 during the ninth clock and clock stretch is canceled, after which the TRCn bit is cleared (reception status) and the SDAAn line is set to high impedance. Release the clock stretch performed while the TRCn bit is 1 (transmission status) by writing to the IICA shift register n.

Remarks

- LRELn: Bit 6 of IICA control register n0 (IICCTLn0)
IICEn: Bit 7 of IICA control register n0 (IICCTLn0)
- n = 0, 1

Figure 13-7. Format of IICA Status Register n (IICSn) (3/3)

ACKDn	Detection of acknowledge (ACK)	
0	Acknowledge was not detected.	
1	Acknowledge was detected.	
Condition for clearing (ACKDn = 0)		Condition for setting (ACKDn = 1)
<ul style="list-style-type: none"> • When a stop condition is detected • At the rising edge of the next byte's first clock • Cleared by LRELn = 1 (exit from communications) • When the IICEn bit changes from 1 to 0 (operation stop) • Reset 		<ul style="list-style-type: none"> • After the SDAAn line is set to low level at the rising edge of SCLAn line's ninth clock

STDn	Detection of start condition	
0	Start condition was not detected.	
1	Start condition was detected. This indicates that the address transfer period is in effect.	
Condition for clearing (STDn = 0)		Condition for setting (STDn = 1)
<ul style="list-style-type: none"> • When a stop condition is detected • At the rising edge of the next byte's first clock following address transfer • Cleared by LRELn = 1 (exit from communications) • When the IICEn bit changes from 1 to 0 (operation stop) • Reset 		<ul style="list-style-type: none"> • When a start condition is detected

SPDn	Detection of stop condition	
0	Stop condition was not detected.	
1	Stop condition was detected. The master device's communication is terminated and the bus is released.	
Condition for clearing (SPDn = 0)		Condition for setting (SPDn = 1)
<ul style="list-style-type: none"> • At the rising edge of the address transfer byte's first clock following setting of this bit and detection of a start condition • When the WUPn bit changes from 1 to 0 • When the IICEn bit changes from 1 to 0 (operation stop) • Reset 		<ul style="list-style-type: none"> • When a stop condition is detected

- Remarks 1.** LRELn: Bit 6 of IICA control register n0 (IICCTLn0)
 IICEn: Bit 7 of IICA control register n0 (IICCTLn0)
- 2.** n = 0, 1

13.3.4 IICA flag register n (IICFn)

This register sets the operation mode of I²C and indicates the status of the I²C bus.

The IICFn register can be set by a 1-bit or 8-bit memory manipulation instruction. However, the STTn clear flag (STCFn) and I²C bus status flag (IICBSYn) bits are read-only.

The IICRSVn bit can be used to enable/disable the communication reservation function.

The STCENn bit can be used to set the initial value of the IICBSYn bit.

The IICRSVn and STCENn bits can be written only when the operation of I²C is disabled (bit 7 (IICEn) of IICA control register n0 (IICCTLn0) = 0). When operation is enabled, the IICFn register can be read.

Reset signal generation clears this register to 00H.

Figure 13-8. Format of IICA Flag Register n (IICFn)

Address: FFF52H (IICF0), FFF56H (IICF1) After reset: 00H R/W^{Note}

Symbol	<7>	<6>	5	4	3	2	<1>	<0>
IICFn	STCFn	IICBSYn	0	0	0	0	STCENn	IICRSVn

STCFn	STTn clear flag	
0	Generate start condition	
1	Start condition generation unsuccessful: clear the STTn flag	
Condition for clearing (STCFn = 0)		Condition for setting (STCFn = 1)
<ul style="list-style-type: none"> • Cleared by STTn = 1 • When IICEn = 0 (operation stop) • Reset 		<ul style="list-style-type: none"> • Generating start condition unsuccessful and the STTn bit cleared to 0 when communication reservation is disabled (IICRSVn = 1).

IICBSYn	I ² C bus status flag	
0	Bus release status (communication initial status when STCENn = 1)	
1	Bus communication status (communication initial status when STCENn = 0)	
Condition for clearing (IICBSYn = 0)		Condition for setting (IICBSYn = 1)
<ul style="list-style-type: none"> • Detection of stop condition • When IICEn = 0 (operation stop) • Reset 		<ul style="list-style-type: none"> • Detection of start condition • Setting of the IICEn bit when STCENn = 0

STCENn	Initial start enable trigger	
0	After operation is enabled (IICEn = 1), enable generation of a start condition upon detection of a stop condition.	
1	After operation is enabled (IICEn = 1), enable generation of a start condition without detecting a stop condition.	
Condition for clearing (STCENn = 0)		Condition for setting (STCENn = 1)
<ul style="list-style-type: none"> • Cleared by instruction • Detection of start condition • Reset 		<ul style="list-style-type: none"> • Set by instruction

IICRSVn	Communication reservation function disable bit	
0	Enable communication reservation	
1	Disable communication reservation	
Condition for clearing (IICRSVn = 0)		Condition for setting (IICRSVn = 1)
<ul style="list-style-type: none"> • Cleared by instruction • Reset 		<ul style="list-style-type: none"> • Set by instruction

Note Bits 6 and 7 are read-only.

- Cautions**
1. Write to the STCENn bit only when the operation is stopped (IICEn = 0).
 2. As the bus release status (IICBSYn = 0) is recognized regardless of the actual bus status when STCENn = 1, when generating the first start condition (STTn = 1), it is necessary to verify that no third party communications are in progress in order to prevent such communications from being destroyed.
 3. Write to IICRSVn only when the operation is stopped (IICEn = 0).

- Remarks**
1. STTn: Bit 1 of IICA control register n0 (IICCTLn0)
IICEn: Bit 7 of IICA control register n0 (IICCTLn0)
 2. n = 0, 1

13.3.5 IICA control register n1 (IICCTLn1)

This register is used to set the operation mode of I²C and detect the statuses of the SCLAn and SDAAn pins.

The IICCTLn1 register can be set by a 1-bit or 8-bit memory manipulation instruction. However, the CLDn and DADn bits are read-only.

Set the IICCTLn1 register, except the WUPn bit, while operation of I²C is disabled (bit 7 (IICEn) of IICA control register n0 (IICCTLn0) is 0).

Reset signal generation clears this register to 00H.

Figure 13-9. Format of IICA Control Register n1 (IICCTLn1) (1/2)

Address: F0231H (IICCTL01), F0239H (IICCTL11) After reset: 00H R/W^{Note 1}

Symbol	<7>	6	<5>	<4>	<3>	<2>	1	<0>
IICCTLn1	WUPn	0	CLDn	DADn	SMCn	DFCn	0	PRSn

WUPn	Control of address match wakeup
0	Stops operation of address match wakeup function in STOP mode.
1	Enables operation of address match wakeup function in STOP mode.
<p>To shift to STOP mode when WUPn = 1, execute the STOP instruction at least three cycles of f_{MCK} after setting (1) the WUPn bit (see Figure 13-22 Flow When Setting WUPn = 1).</p> <p>Clear (0) the WUPn bit after the address has matched or an extension code has been received. The subsequent communication can be entered by the clearing (0) WUPn bit. (The clock stretch must be released and transmit data must be written after the WUPn bit has been cleared (0).)</p> <p>The interrupt timing when the address has matched or when an extension code has been received, while WUPn = 1, is identical to the interrupt timing when WUPn = 0. (A delay of the difference of sampling by the clock will occur.) Furthermore, when WUPn = 1, a stop condition interrupt is not generated even if the SPIEn bit is set to 1.</p>	
Condition for clearing (WUPn = 0)	Condition for setting (WUPn = 1)
<ul style="list-style-type: none"> ●Cleared by instruction (after address match or extension code reception) 	<ul style="list-style-type: none"> ●Set by instruction (when the MSTSn, EXCn, and COIn bits are "0", and the STDn bit also "0" (communication not entered))^{Note 2}

- Notes 1.** Bits 4 and 5 are read-only.
- 2.** The status of the IICA status register n (IICCSn) must be checked and the WUPn bit must be set during the period shown below.

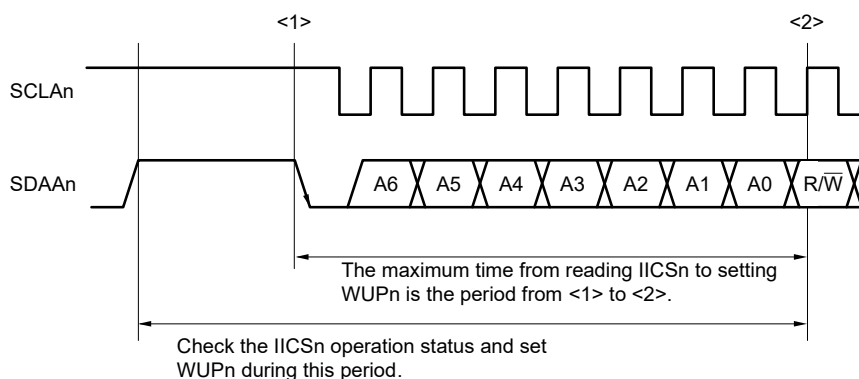

Remark n = 0, 1

Figure 13-9. Format of IICA Control Register n1 (IICCTLn1) (2/2)

CLDn	Detection of SCLAn pin level (valid only when IICEn = 1)	
0	The SCLAn pin was detected at low level.	
1	The SCLAn pin was detected at high level.	
Condition for clearing (CLDn = 0)		Condition for setting (CLDn = 1)
<ul style="list-style-type: none"> • When the SCLAn pin is at low level • When IICEn = 0 (operation stop) • Reset 		<ul style="list-style-type: none"> • When the SCLAn pin is at high level

DADn	Detection of SDAAn pin level (valid only when IICEn = 1)	
0	The SDAAn pin was detected at low level.	
1	The SDAAn pin was detected at high level.	
Condition for clearing (DADn = 0)		Condition for setting (DADn = 1)
<ul style="list-style-type: none"> • When the SDAAn pin is at low level • When IICEn = 0 (operation stop) • Reset 		<ul style="list-style-type: none"> • When the SDAAn pin is at high level

SMCn	Operation mode switching	
0	Operates in standard mode (fastest transfer rate: 100 kbps).	
1	Operates in fast mode (fastest transfer rate: 400 kbps) or fast mode plus (fastest transfer rate: 1 Mbps).	

DFCn	Digital filter operation control	
0	Digital filter off.	
1	Digital filter on.	
<p>Use the digital filter only in fast mode and fast mode plus.</p> <p>The digital filter is used for noise elimination.</p> <p>The transfer clock does not vary, regardless of the DFCn bit being set (1) or cleared (0).</p>		

PRSn	IICA operation clock (f _{MCK})	
0	Selects f _{CLK} (1 MHz ≤ f _{CLK} ≤ 20 MHz).	
1	Selects f _{CLK} /2 (20 MHz < f _{CLK}).	

- Cautions**
1. The fastest operation frequency of the IICA operation clock (f_{MCK}) is 20 MHz (max.). Set bit 0 (PRSn) of the IICA control register n1 (IICCTLn1) to "1" only when the f_{CLK} exceeds 20 MHz.
 2. Note the minimum f_{CLK} operation frequency when setting the transfer clock. The minimum f_{CLK} operation frequency for serial interface IICA is determined according to the mode.
 - Fast mode: f_{CLK} = 3.5 MHz (min.)
 - Fast mode plus: f_{CLK} = 10 MHz (min.)
 - Normal mode: f_{CLK} = 1 MHz (min.)

- Remarks**
1. IICEn: Bit 7 of IICA control register n0 (IICCTLn0)
 2. n = 0, 1

13.3.6 IICA low-level width setting register n (IICWLn)

This register is used to set the low-level width (t_{LOW}) of the SCLAn pin signal that is output by serial interface IICA and to control the SDAAn pin signal.

The IICWLn register can be set by an 8-bit memory manipulation instruction.

Set the IICWLn register while operation of I²C is disabled (bit 7 (IICEn) of IICA control register n0 (IICCTLn0) is 0).

Reset signal generation sets this register to FFH.

For details about setting the IICWLn register, see **13.4.2 Setting transfer clock by using IICWLn and IICWHn registers.**

The data hold time is one-quarter of the time set by the IICWLn register.

Figure 13-10. Format of IICA Low-Level Width Setting Register n (IICWLn)

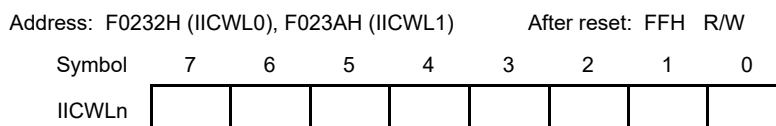

13.3.7 IICA high-level width setting register n (IICWHn)

This register is used to set the high-level width of the SCLAn pin signal that is output by serial interface IICA and to control the SDAAn pin signal.

The IICWHn register can be set by an 8-bit memory manipulation instruction.

Set the IICWHn register while operation of I²C is disabled (bit 7 (IICEn) of IICA control register n0 (IICCTLn0) is 0).

Reset signal generation sets this register to FFH.

Figure 13-11. Format of IICA High-Level Width Setting Register n (IICWHn)

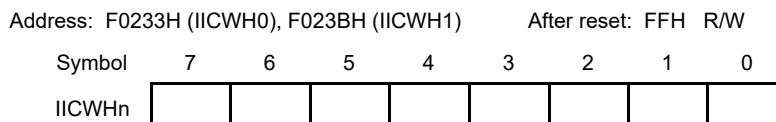

- Remarks 1.** For setting procedures of the transfer clock on master side and of the IICWLn and IICWHn registers on slave side, see **13.4.2 (1)** and **13.4.2 (2)**, respectively.
- 2.** n = 0, 1

13.3.8 Port mode register 6 (PM6)

This register sets the input/output of port 6 in 1-bit units.

When using the P60/SCLA0 pin as clock I/O and the P61/SDAA0 pin as serial data I/O, clear PM60 and PM61, and the output latches of P60 and P61 to 0.

Set the IICEn bit (bit 7 of IICA control register n0 (IICCTLn0)) to 1 before setting the output mode because the P60/SCLA0 and P61/SDAA0 pins output a low level (fixed) when the IICEn bit is 0.

The PM6 register can be set by a 1-bit or 8-bit memory manipulation instruction.

Reset signal generation sets this register to FFH.

Figure 13-12. Format of Port Mode Register 6 (PM6)

Address: FFF26H After reset: FFH R/W

Symbol	7	6	5	4	3	2	1	0
PM6	1	1	1	1	PM63	PM62	PM61	PM60

PM6n	P6n pin I/O mode selection (n = 0 to 3)
0	Output mode (output buffer on)
1	Input mode (output buffer off)

13.4 I²C Bus Mode Functions

13.4.1 Pin configuration

The serial clock pin (SCLAn) and the serial data bus pin (SDAAn) are configured as follows.

- (1) SCLAn This pin is used for serial clock input and output.
 This pin is an N-ch open-drain output for both master and slave devices. Input is Schmitt input.
- (2) SDAAn This pin is used for serial data input and output.
 This pin is an N-ch open-drain output for both master and slave devices. Input is Schmitt input.

Since outputs from the serial clock line and the serial data bus line are N-ch open-drain outputs, an external pull-up resistor is required.

Figure 13-13. Pin Configuration Diagram

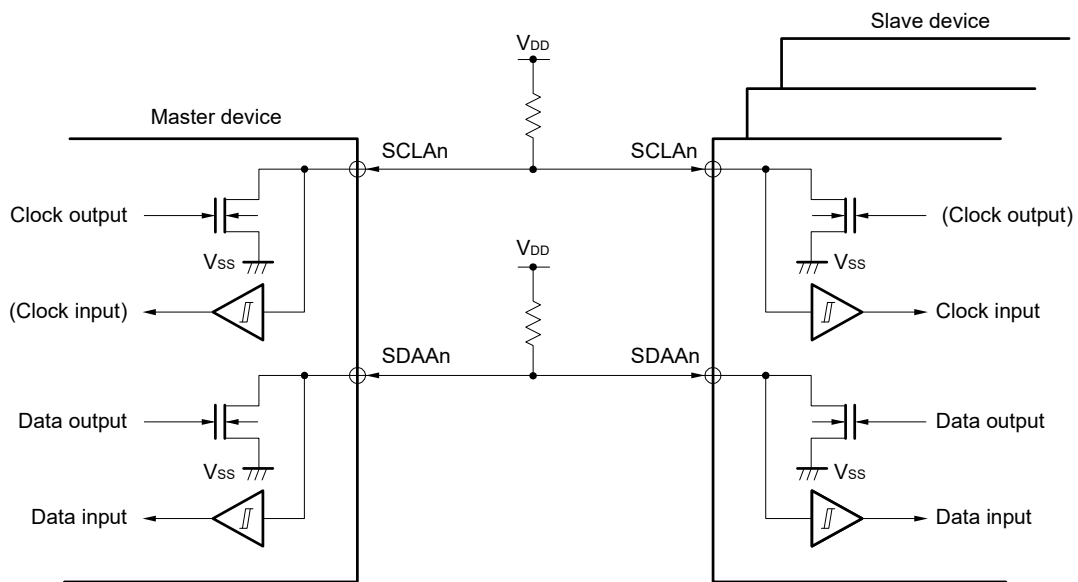

Remark n = 0, 1

13.4.2 Setting transfer clock by using IICWLn and IICWHn registers

(1) Setting transfer clock on master side

$$\text{Transfer clock} = \frac{f_{\text{MCK}}}{\text{IICWL} + \text{IICWH} + f_{\text{MCK}}(t_{\text{R}} + t_{\text{F}})}$$

At this time, the optimal setting values of the IICWLn and IICWHn registers are as follows.
(The fractional parts of all setting values are rounded up.)

- When the fast mode

$$\begin{aligned} \text{IICWLn} &= \frac{0.52}{\text{Transfer clock}} \times f_{\text{MCK}} \\ \text{IICWHn} &= \left(\frac{0.48}{\text{Transfer clock}} - t_{\text{R}} - t_{\text{F}} \right) \times f_{\text{MCK}} \end{aligned}$$

- When the normal mode

$$\begin{aligned} \text{IICWLn} &= \frac{0.47}{\text{Transfer clock}} \times f_{\text{MCK}} \\ \text{IICWHn} &= \left(\frac{0.53}{\text{Transfer clock}} - t_{\text{R}} - t_{\text{F}} \right) \times f_{\text{MCK}} \end{aligned}$$

- When the fast mode plus

$$\begin{aligned} \text{IICWLn} &= \frac{0.50}{\text{Transfer clock}} \times f_{\text{MCK}} \\ \text{IICWHn} &= \left(\frac{0.50}{\text{Transfer clock}} - t_{\text{R}} - t_{\text{F}} \right) \times f_{\text{MCK}} \end{aligned}$$

(2) Setting IICWLn and IICWHn registers on slave side

(The fractional parts of all setting values are truncated.)

- When the fast mode

$$\begin{aligned} \text{IICWLn} &= 1.3 \mu\text{s} \times f_{\text{MCK}} \\ \text{IICWHn} &= (1.2 \mu\text{s} - t_{\text{R}} - t_{\text{F}}) \times f_{\text{MCK}} \end{aligned}$$

- When the normal mode

$$\begin{aligned} \text{IICWLn} &= 4.7 \mu\text{s} \times f_{\text{MCK}} \\ \text{IICWHn} &= (5.3 \mu\text{s} - t_{\text{R}} - t_{\text{F}}) \times f_{\text{MCK}} \end{aligned}$$

- When the fast mode plus

$$\begin{aligned} \text{IICWLn} &= 0.50 \mu\text{s} \times f_{\text{MCK}} \\ \text{IICWHn} &= (0.50 \mu\text{s} - t_{\text{R}} - t_{\text{F}}) \times f_{\text{MCK}} \end{aligned}$$

(**Caution** and **Remarks** are listed on the next page.)

- Cautions**
- 1. The fastest operation frequency of the IICA operation clock (f_{MCK}) is 20 MHz (max.).**
Set bit 0 (PRSn) of the IICA control register n1 (IICCTLn1) to "1" only when the f_{CLK} exceeds 20 MHz.
 - 2. Note the minimum f_{CLK} operation frequency when setting the transfer clock. The minimum f_{CLK} operation frequency for serial interface IICA is determined according to the mode.**
Fast mode: $f_{CLK} = 3.5$ MHz (min.)
Fast mode plus: $f_{CLK} = 10$ MHz (min.)
Normal mode: $f_{CLK} = 1$ MHz (min.)

- Remarks**
- 1.** Calculate the rise time (t_R) and fall time (t_F) of the SDAAn and SCLAn signals separately, because they differ depending on the pull-up resistance and wire load.
 - 2.** IICWLn: IICA low-level width setting register n
IICWHn: IICA high-level width setting register n
 t_F : SDAAn and SCLAn signal falling times
 t_R : SDAAn and SCLAn signal rising times
 f_{MCK} : IICA operation clock frequency
 - 3.** $n = 0, 1$

13.5 I²C Bus Definitions and Control Methods

The following section describes the I²C bus's serial data communication format and the signals used by the I²C bus. Figure 13-14 shows the transfer timing for the "start condition", "address", "data", and "stop condition" output via the I²C bus's serial data bus.

Figure 13-14. I²C Bus Serial Data Transfer Timing

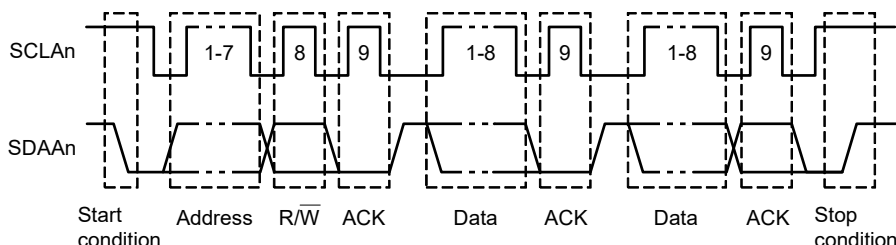

The master device generates the start condition, slave address, and stop condition. The acknowledge (ACK) can be generated by either the master or slave device (normally, it is output by the device that receives 8-bit data).

The serial clock (SCLAn) is continuously output by the master device. However, in the slave device, the SCLAn pin low level period can be extended and a clock stretch can be inserted.

13.5.1 Start conditions

A start condition is met when the SCLAn pin is at high level and the SDAAn pin changes from high level to low level. The start conditions for the SCLAn pin and SDAAn pin are signals that the master device generates to the slave device when starting a serial transfer. When the device is used as a slave, start conditions can be detected.

Figure 13-15. Start Conditions

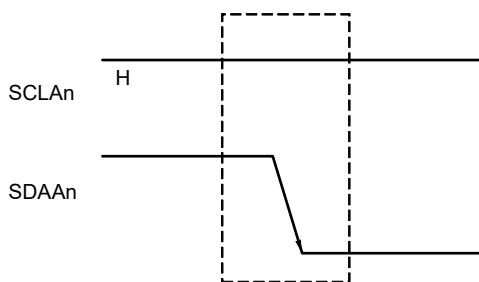

A start condition is output when bit 1 (STTn) of IICA control register n0 (IICCTLn0) is set (1) after a stop condition has been detected (SPDn: Bit 0 of the IICA status register n (IICSn) = 1). When a start condition is detected, bit 1 (STDn) of the IICSn register is set (1).

Remark n = 0, 1

13.5.2 Addresses

The address is defined by the 7 bits of data that follow the start condition.

An address is a 7-bit data segment that is output in order to select one of the slave devices that are connected to the master device via the bus lines. Therefore, each slave device connected via the bus lines must have a unique address.

The slave devices include hardware that detects the start condition and checks whether or not the 7-bit address data matches the data values stored in the slave address register n (SVAn). If the address data matches the SVAn register values, the slave device is selected and communicates with the master device until the master device generates a start condition or stop condition.

Figure 13-16. Address

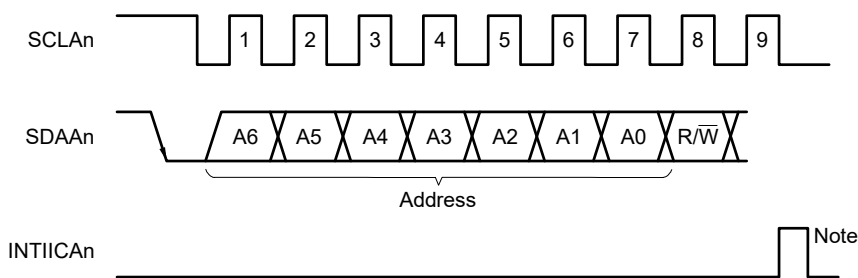

Note INTIICAn is not issued if data other than a local address or extension code is received during slave device operation.

Addresses are output when a total of 8 bits consisting of the slave address and the transfer direction described in **13.5.3 Transfer direction specification** are written to the IICAn shift register n (IICAn). The received addresses are written to the IICAn register.

The slave address is assigned to the higher 7 bits of the IICAn register.

13.5.3 Transfer direction specification

In addition to the 7-bit address data, the master device sends 1 bit that specifies the transfer direction.

When this transfer direction specification bit has a value of “0”, it indicates that the master device is transmitting data to a slave device. When the transfer direction specification bit has a value of “1”, it indicates that the master device is receiving data from a slave device.

Figure 13-17. Transfer Direction Specification

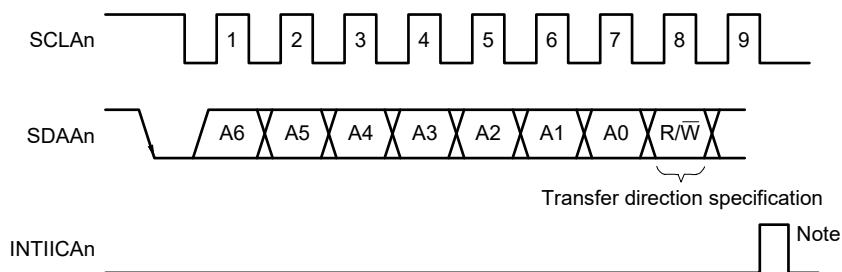

Note INTIICAn is not issued if data other than a local address or extension code is received during slave device operation.

Remark n = 0, 1

13.5.4 Acknowledge (ACK)

ACK is used to check the status of serial data at the transmission and reception sides.

The reception side returns ACK each time it has received 8-bit data.

The transmission side usually receives ACK after transmitting 8-bit data. When ACK is returned from the reception side, it is assumed that reception has been correctly performed and processing is continued. Whether ACK has been detected can be checked by using bit 2 (ACKDn) of the IICA status register n (IICSn).

When the master receives the last data item, it does not return ACK and instead generates a stop condition. If a slave does not return ACK after receiving data, the master outputs a stop condition or restart condition and stops transmission. If ACK is not returned, the possible causes are as follows.

- <1> Reception was not performed normally.
- <2> The final data item was received.
- <3> The reception side specified by the address does not exist.

To generate ACK, the reception side makes the SDAAn line low at the ninth clock (indicating normal reception).

Automatic generation of ACK is enabled by setting bit 2 (ACKEn) of IICA control register n0 (IICCTLn0) to 1. Bit 3 (TRCn) of the IICSn register is set by the data of the eighth bit that follows 7-bit address information. Usually, set the ACKEn bit to 1 for reception (TRCn = 0).

If a slave can receive no more data during reception (TRCn = 0) or does not require the next data item, then the slave must inform the master, by clearing the ACKEn bit to 0, that it will not receive any more data.

When the master does not require the next data item during reception (TRCn = 0), it must clear the ACKEn bit to 0 so that ACK is not generated. In this way, the master informs a slave at the transmission side that it does not require any more data (transmission will be stopped).

Figure 13-18. ACK

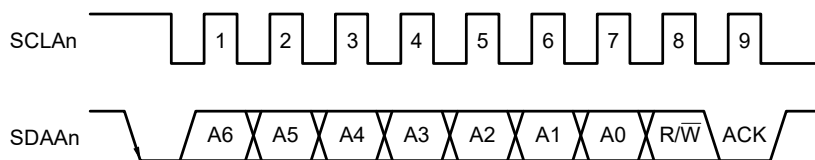

When the local address is received, ACK is automatically generated, regardless of the value of the ACKEn bit. When an address other than that of the local address is received, ACK is not generated (NACK).

When an extension code is received, ACK is generated if the ACKEn bit is set to 1 in advance.

How ACK is generated when data is received differs as follows depending on the setting of the clock stretch timing.

- When 8-clock clock stretch state is selected (bit 3 (WTIMn) of IICCTLn0 register = 0):
By setting the ACKEn bit to 1 before releasing the clock stretch state, ACK is generated at the falling edge of the eighth clock of the SCLAn pin.
- When 9-clock clock stretch state is selected (bit 3 (WTIMn) of IICCTLn0 register = 1):
ACK is generated by setting the ACKEn bit to 1 in advance.

Remark n = 0, 1

13.5.5 Stop condition

When the SCLAn pin is at high level, changing the SDAAn pin from low level to high level generates a stop condition.

A stop condition is a signal that the master device generates to the slave device when serial transfer has been completed. When the device is used as a slave, stop conditions can be detected.

Figure 13-19. Stop Condition

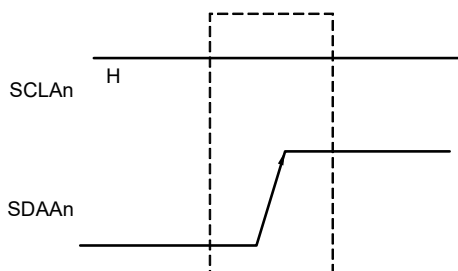

A stop condition is generated when bit 0 (SPTn) of IICA control register n0 (IICCTLn0) is set to 1. When the stop condition is detected, bit 0 (SPDn) of the IICA status register n (IICSn) is set to 1 and INTIICAn is generated when bit 4 (SPIEn) of the IICCTLn0 register is set to 1.

Remark n = 0, 1

13.5.6 Clock stretch

The clock stretch is used to notify the communication partner that a device (master or slave) is preparing to transmit or receive data (i.e., is in a clock stretch state).

Setting the SCLAn pin to low level notifies the communication partner of the clock stretch state. When clock stretch state has been canceled for both the master and slave devices, the next data transfer can begin.

Figure 13-20. Wait (1/2)

(1) When master device has a nine-clock clock stretch and slave device has an eight-clock clock stretch (master transmits, slave receives, and ACKEn = 1)

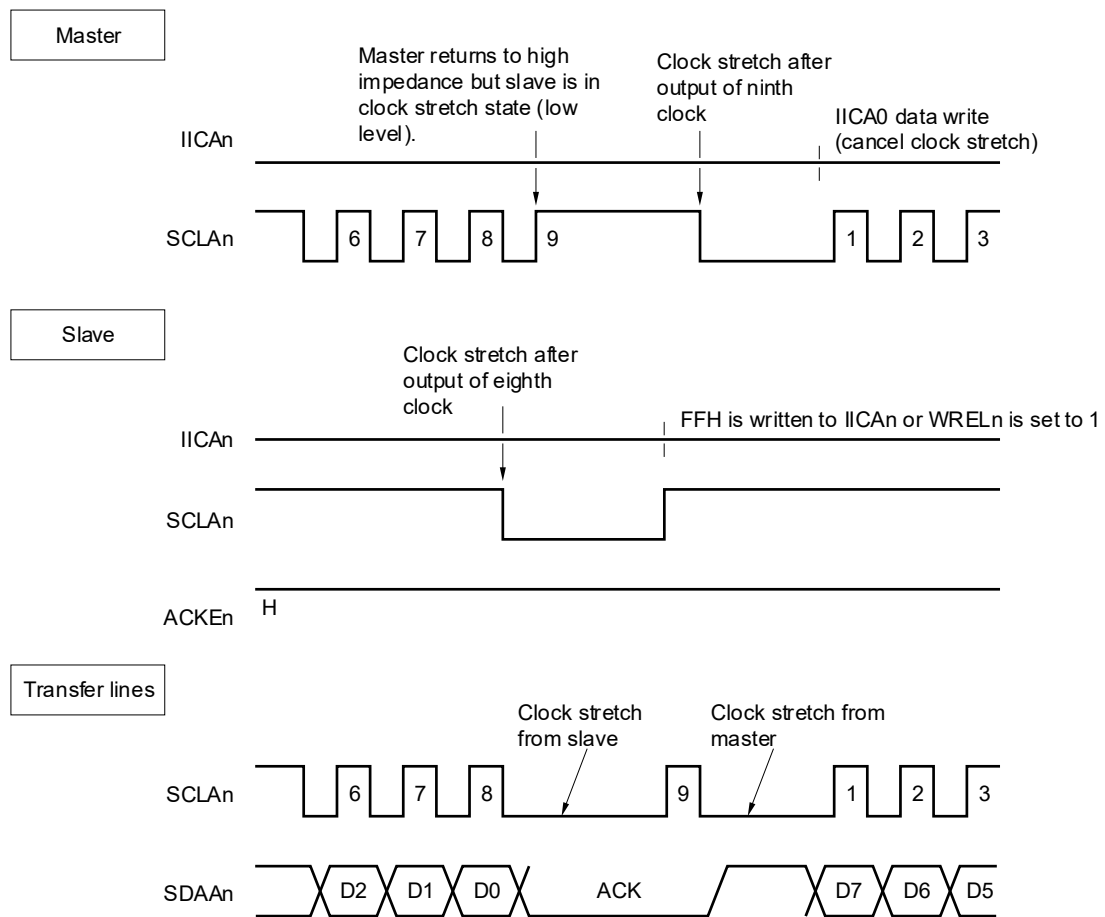

Remark n = 0, 1

Figure 13-20. Clock stretch (2/2)

(2) When master and slave devices both have a nine-clock clock stretch (master transmits, slave receives, and ACKEn = 1)

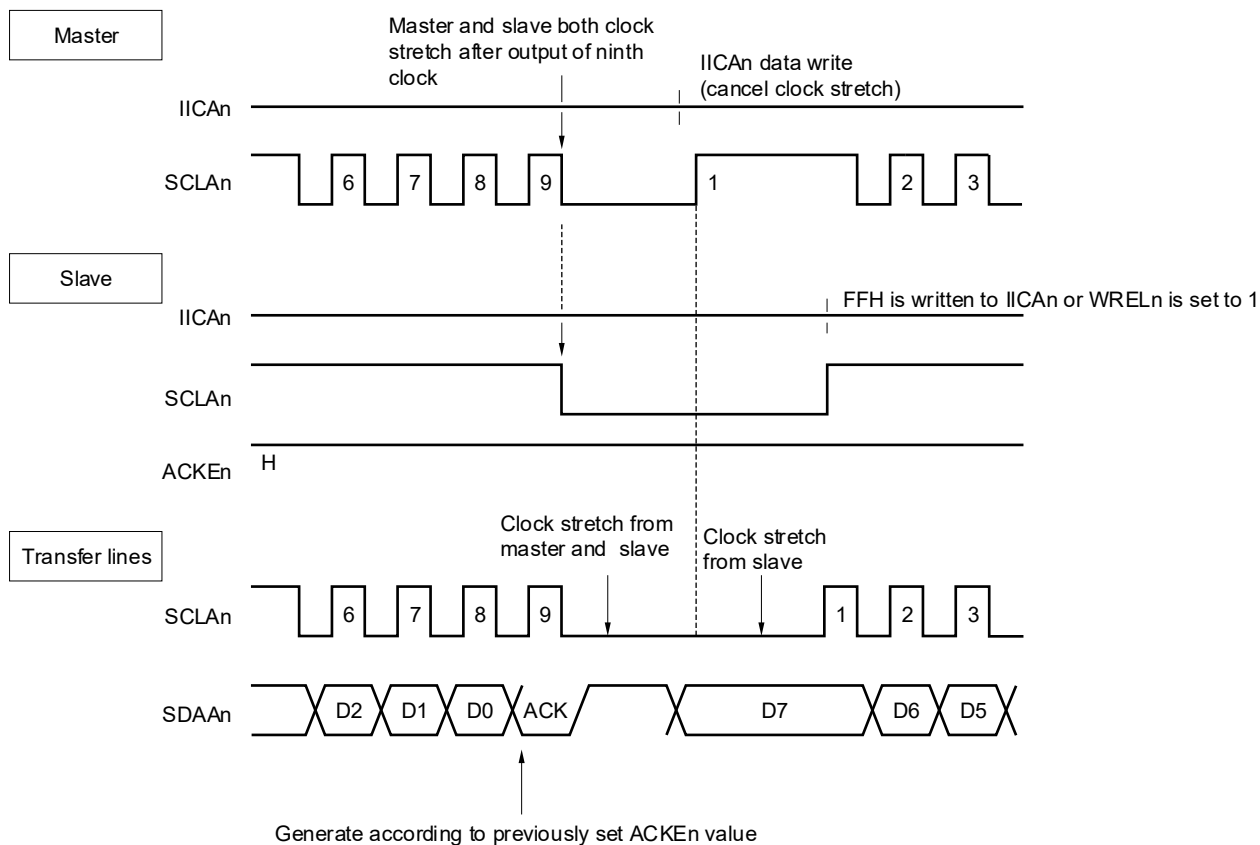

Remark ACKEn: Bit 2 of IICA control register n0 (IICCTLn0)
 WRELn: Bit 5 of IICA control register n0 (IICCTLn0)

A clock stretch may be automatically generated depending on the setting of bit 3 (WTIMn) of IICA control register n0 (IICCTLn0).

Normally, the receiving side cancels the clock stretch state when bit 5 (WRELn) of the IICCTLn0 register is set to 1 or when FFH is written to the IICA shift register n (IICAn), and the transmitting side cancels the clock stretch state when data is written to the IICAn register.

The master device can also cancel the clock stretch state via either of the following methods.

- By setting bit 1 (STTn) of the IICCTLn0 register to 1
- By setting bit 0 (SPTn) of the IICCTLn0 register to 1

Remark n = 0, 1

13.5.7 Canceling clock stretch

The I²C usually cancels a clock stretch state by the following processing.

- Writing data to the IICA shift register n (IICAn)
- Setting bit 5 (WRELn) of IICA control register n0 (IICCTLn0) (canceling clock stretch)
- Setting bit 1 (STTn) of the IICCTLn0 register (generating start condition)^{Note}
- Setting bit 0 (SPTn) of the IICCTLn0 register (generating stop condition)^{Note}

Note Master only

When the above clock stretch canceling processing is executed, the I²C cancels the clock stretch state and communication is resumed.

To cancel a clock stretch state and transmit data (including addresses), write the data to the IICAn register.

To receive data after canceling a clock stretch state, or to complete data transmission, set bit 5 (WRELn) of the IICCTLn0 register to 1.

To generate a restart condition after canceling a clock stretch state, set bit 1 (STTn) of the IICCTLn0 register to 1.

To generate a stop condition after canceling a clock stretch state, set bit n (SPTn) of the IICCTLn0 register to 1.

Execute the canceling processing only once for one clock stretch state.

If, for example, data is written to the IICAn register after canceling a clock stretch state by setting the WRELn bit to 1, an incorrect value may be output to SDAAn line because the timing for changing the SDAAn line conflicts with the timing for writing the IICAn register.

In addition to the above, communication is stopped if the IICEn bit is cleared to 0 when communication has been aborted, so that the clock stretch state can be canceled.

If the I²C bus has deadlocked due to noise, processing is saved from communication by setting bit 6 (LRELn) of the IICCTLn0 register, so that the clock stretch state can be canceled.

Caution If a processing to cancel a clock stretch state is executed when WUPn = 1, the clock stretch state will not be canceled.

Remark n = 0, 1

13.5.8 Interrupt request (INTIICAn) generation timing and clock stretch control

The setting of bit 3 (WTIMn) of IICA control register n0 (IICCTLn0) determines the timing by which INTIICAn is generated and the corresponding clock stretch control, as shown in Table 13-2.

Table 13-2. INTIICAn Generation Timing and Clock Stretch Control

WTIMn	During Slave Device Operation			During Master Device Operation		
	Address	Data Reception	Data Transmission	Address	Data Reception	Data Transmission
0	gNotes 1, 2	gNote 2	gNote 2	9	8	8
1	gNotes 1, 2	gNote 2	gNote 2	9	9	9

Notes 1. The slave device's INTIICAn signal and clock stretch period occurs at the falling edge of the ninth clock only when there is a match with the address set to the slave address register n (SVAn).

At this point, ACK is generated regardless of the value set to the IICCTLn0 register's bit 2 (ACKEn). For a slave device that has received an extension code, INTIICAn occurs at the falling edge of the eighth clock.

However, if the address does not match after restart, INTIICAn is generated at the falling edge of the 9th clock, but clock stretch does not occur.

2. If the received address does not match the contents of the slave address register n (SVAn) and extension code is not received, neither INTIICAn nor a clock stretch occurs.

Remark The numbers in the table indicate the number of the serial clock's clock signals. Interrupt requests and clock stretch control are both synchronized with the falling edge of these clock signals.

(1) During address transmission/reception

- Slave device operation: Interrupt and clock stretch timing are determined depending on the conditions described in Notes 1 and 2 above, regardless of the WTIMn bit.
- Master device operation: Interrupt and clock stretch timing occur at the falling edge of the ninth clock regardless of the WTIMn bit.

(2) During data reception

- Master/slave device operation: Interrupt and clock stretch timing are determined according to the WTIMn bit.

(3) During data transmission

- Master/slave device operation: Interrupt and clock stretch timing are determined according to the WTIMn bit.

(4) Clock stretch cancellation method

The four clock stretch cancellation methods are as follows.

- Writing data to the IICA shift register n (IICAn)
- Setting bit 5 (WRELn) of IICA control register n0 (IICCTLn0) (canceling clock stretch)
- Setting bit 1 (STTn) of IICCTLn0 register (generating start condition)^{Note}
- Setting bit 0 (SPTn) of IICCTLn0 register (generating stop condition)^{Note}

Note Master only.

When an 8-clock clock stretch has been selected (WTIMn = 0), the presence/absence of ACK generation must be determined prior to clock stretch cancellation.

(5) Stop condition detection

INTIICAn is generated when a stop condition is detected (only when SPIEn = 1).

Remark n = 0, 1

13.5.9 Address match detection method

In I²C bus mode, the master device can select a particular slave device by transmitting the corresponding slave address.

Address match can be detected automatically by hardware. An interrupt request (INTIICAn) occurs when the address set to the slave address register n (SVAn) matches the slave address sent by the master device, or when an extension code has been received.

13.5.10 Error detection

In I²C bus mode, the status of the serial data bus (SDAAn) during data transmission is captured by the IICA shift register n (IICAn) of the transmitting device, so the IICA data prior to transmission can be compared with the transmitted IICA data to enable detection of transmission errors. A transmission error is judged as having occurred when the compared data values do not match.

13.5.11 Extension code

- (1) When the higher 4 bits of the receive address are either "0000" or "1111", the extension code reception flag (EXCn) is set to 1 for extension code reception and an interrupt request (INTIICAn) is issued at the falling edge of the eighth clock. The local address stored in the slave address register n (SVAn) is not affected.
- (2) The settings below are specified if 11110xx0 is transferred from the master by using a 10-bit address transfer when the SVAn register is set to 11110xx0. Note that INTIICAn occurs at the falling edge of the eighth clock.
 - Higher four bits of data match: EXCn = 1
 - Seven bits of data match: COIn = 1

Remark EXCn: Bit 5 of IICA status register n (IICSn)
COIn: Bit 4 of IICA status register n (IICSn)

- (3) Since the processing after the interrupt request occurs differs according to the data that follows the extension code, such processing is performed by software.
If the extension code is received while a slave device is operating, then the slave device is participating in communication even if its address does not match.
For example, after the extension code is received, if you do not wish to operate the target device as a slave device, set bit 6 (LRELn) of IICA control register n0 (IICCTLn0) to 1 to set the standby mode for the next communication operation.

Table 13-3. Bit Definitions of Major Extension Codes

Slave Address	R/W Bit	Description
0 0 0 0 0 0 0	0	General call address
1 1 1 1 0 x x	0	10-bit slave address specification (during address authentication)
1 1 1 1 0 x x	1	10-bit slave address specification (after address match, when read command is issued)

- Remarks**
1. See the I²C bus specifications issued by NXP Semiconductors for details of extension codes other than those described above.
 2. n = 0, 1

13.5.12 Arbitration

When several master devices simultaneously generate a start condition (when the STTn bit is set to 1 before the STDn bit is set to 1), communication among the master devices is performed as the number of clocks are adjusted until the data differs. This kind of operation is called arbitration.

When one of the master devices loses in arbitration, an arbitration loss flag (ALDn) in the IICA status register n (IICSn) is set (1) via the timing by which the arbitration loss occurred, and the SCLAn and SDAAn lines are both set to high impedance, which releases the bus.

The arbitration loss is detected based on the timing of the next interrupt request (the eighth or ninth clock, when a stop condition is detected, etc.) and the ALDn = 1 setting that has been made by software.

For details of interrupt request timing, see **13.5.8 Interrupt request (INTIICAn) generation timing and clock stretch control**.

Remark STDn: Bit 1 of IICA status register n (IICSn)
 STTn: Bit 1 of IICA control register n0 (IICCTLn0)

Figure 13-21. Arbitration Timing Example

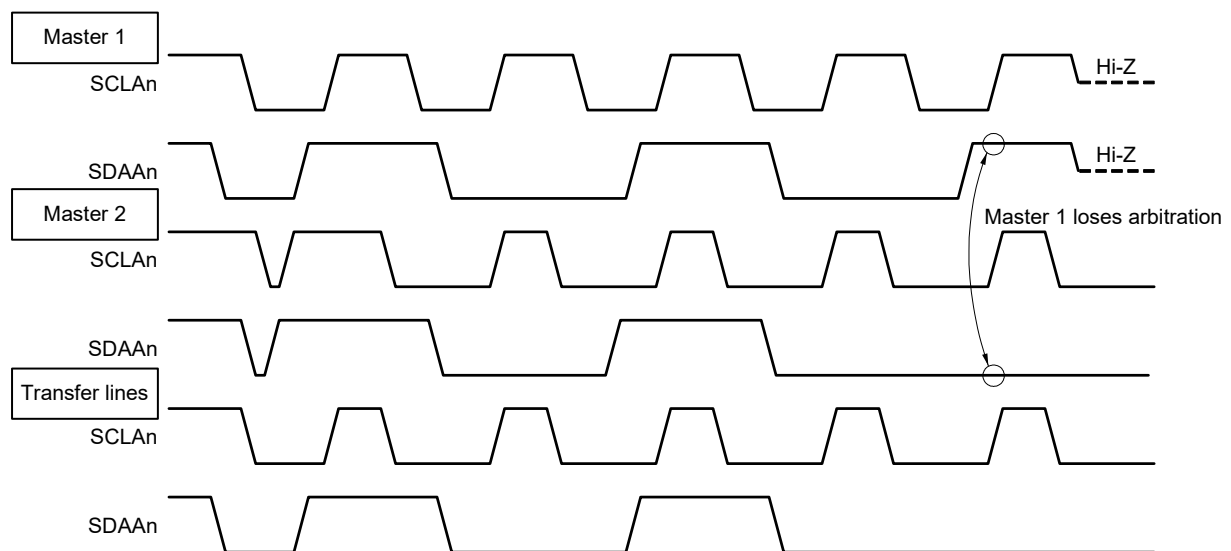

Remark n = 0, 1

Table 13-4. Status During Arbitration and Interrupt Request Generation Timing

Status During Arbitration	Interrupt Request Generation Timing
During address transmission	At falling edge of eighth or ninth clock following byte transfer ^{Note 1}
Read/write data after address transmission	
During extension code transmission	
Read/write data after extension code transmission	
During data transmission	
During ACK transfer period after data transmission	
When restart condition is detected during data transfer	
When stop condition is detected during data transfer	When stop condition is generated (when SPIEn = 1) ^{Note 2}
When data is at low level while attempting to generate a restart condition	At falling edge of eighth or ninth clock following byte transfer ^{Note 1}
When stop condition is detected while attempting to generate a restart condition	When stop condition is generated (when SPIEn = 1) ^{Note 2}
When data is at low level while attempting to generate a stop condition	At falling edge of eighth or ninth clock following byte transfer ^{Note 1}
When SCLAn is at low level while attempting to generate a restart condition	

Notes 1. When the WTIMn bit (bit 3 of IICA control register n0 (IICCTLn0)) = 1, an interrupt request occurs at the falling edge of the ninth clock. When WTIMn = 0 and the extension code's slave address is received, an interrupt request occurs at the falling edge of the eighth clock.

2. When there is a chance that arbitration will occur, set SPIEn = 1 for master device operation.

Remarks 1. SPIEn: Bit 4 of IICA control register n0 (IICCTLn0)

2. n = 0, 1

13.5.13 Wakeup function

The I²C bus slave function is a function that generates an interrupt request signal (INTIICAn) when a local address and extension code have been received.

This function makes processing more efficient by preventing unnecessary INTIICAn signal from occurring when addresses do not match.

When a start condition is detected, wakeup standby mode is set. This wakeup standby mode is in effect while addresses are transmitted due to the possibility that an arbitration loss may change the master device (which has generated a start condition) to a slave device.

To use the wakeup function in the STOP mode, set the WUPn bit to 1. Addresses can be received regardless of the operation clock. An interrupt request signal (INTIICAn) is also generated when a local address and extension code have been received. Operation returns to normal operation by using an instruction to clear (0) the WUPn bit after this interrupt has been generated.

Figure 13-22 shows the flow for setting WUPn = 1 and Figure 13-23 shows the flow for setting WUPn = 0 upon an address match.

Figure 13-22. Flow When Setting WUPn = 1

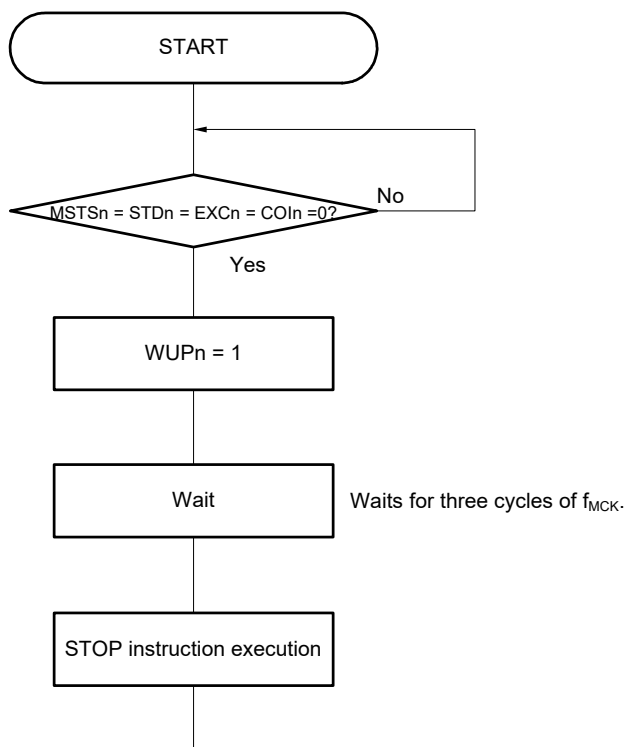

Remark n = 0, 1

Figure 13-23. Flow When Setting WUPn = 0 upon Address Match (Including Extension Code Reception)

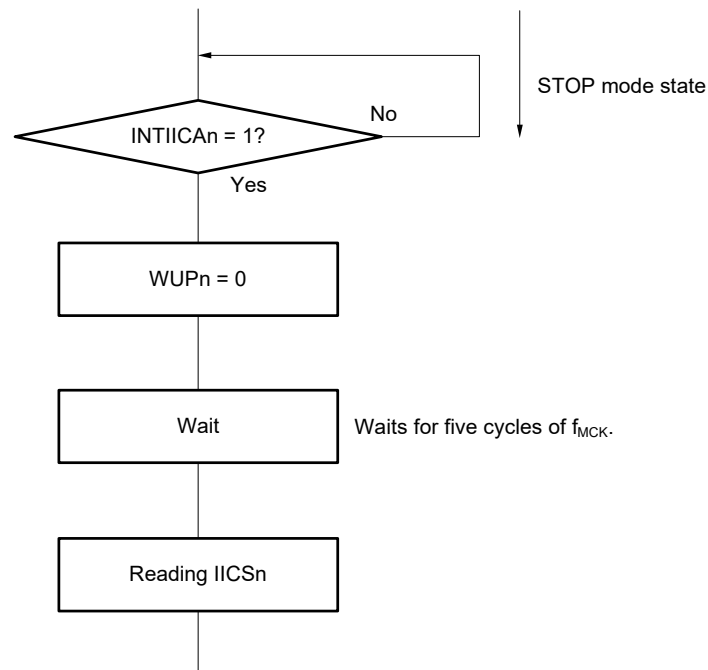

Executes processing corresponding to the operation to be executed after checking the operation state of serial interface IICA.

Use the following flows to perform the processing to release the STOP mode other than by an interrupt request (INTIICAn) generated from serial interface IICA.

- When operating next IIC communication as master: Flow shown in Figure 13-24.
- When operating next IIC communication as slave:
 - When restored by INTIICAn interrupt: Same as the flow in Figure 13-23.
 - When restored by other than INTIICAn interrupt: Wait for INTIICAn interrupt with WUPn left set to 1.

Remark n = 0, 1

Figure 13-24. When Operating as Master Device after Releasing STOP Mode other than by INTIICAn

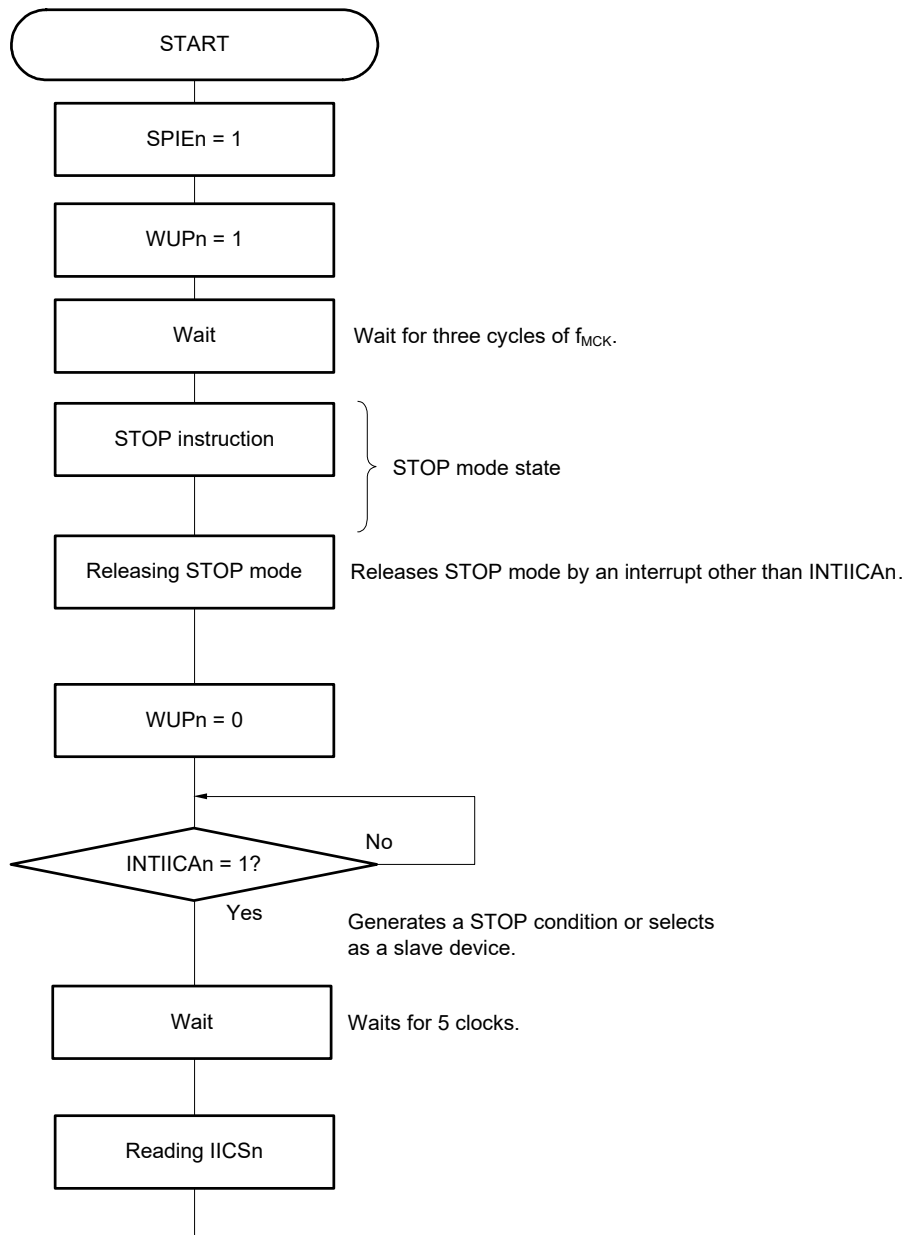

Executes processing corresponding to the operation to be executed after checking the operation state of serial interface IICA.

Remark n = 0, 1

13.5.14 Communication reservation

(1) When communication reservation function is enabled (bit n (IICRSVn) of IICA flag register n (IICFn) = 0)

To start master device communications when not currently using a bus, a communication reservation can be made to enable transmission of a start condition when the bus is released. There are two modes under which the bus is not used.

- When arbitration results in neither master nor slave operation
- When an extension code is received and slave operation is disabled (ACK is not returned and the bus was released by setting bit 6 (LRELn) of IICA control register n0 (IICCTLn0) to 1 and saving communication).

If bit 1 (STTn) of the IICCTLn0 register is set to 1 while the bus is not used (after a stop condition is detected), a start condition is automatically generated and wait state is set.

If an address is written to the IICA shift register n (IICAn) after bit 4 (SPIEn) of the IICCTLn0 register was set to 1, and it was detected by generation of an interrupt request signal (INTIICAn) that the bus was released (detection of the stop condition), then the device automatically starts communication as the master. Data written to the IICAn register before the stop condition is detected is invalid.

When the STTn bit has been set to 1, the operation mode (as start condition or as communication reservation) is determined according to the bus status.

- If the bus has been released a start condition is generated
- If the bus has not been released (standby mode) communication reservation

Check whether the communication reservation operates or not by using the MSTSn bit (bit 7 of the IICA status register n (IICSn)) after the STTn bit is set to 1 and the wait time elapses.

Use software to secure the wait time calculated by the following expression.

Wait time from setting STTn = 1 to checking the MSTSn flag:
 $(IICWLn \text{ setting value} + IICWHn \text{ setting value} + 4) / f_{MCK} + t_F \times 2$

- Remarks**
1. IICWLn: IICA low-level width setting register n
 IICWHn: IICA high-level width setting register n
 t_F: SDAAn and SCLAn signal falling times
 f_{MCK}: IICA operation clock frequency
 2. n = 0, 1

Figure 13-25 shows the communication reservation timing.

Figure 13-25. Communication Reservation Timing

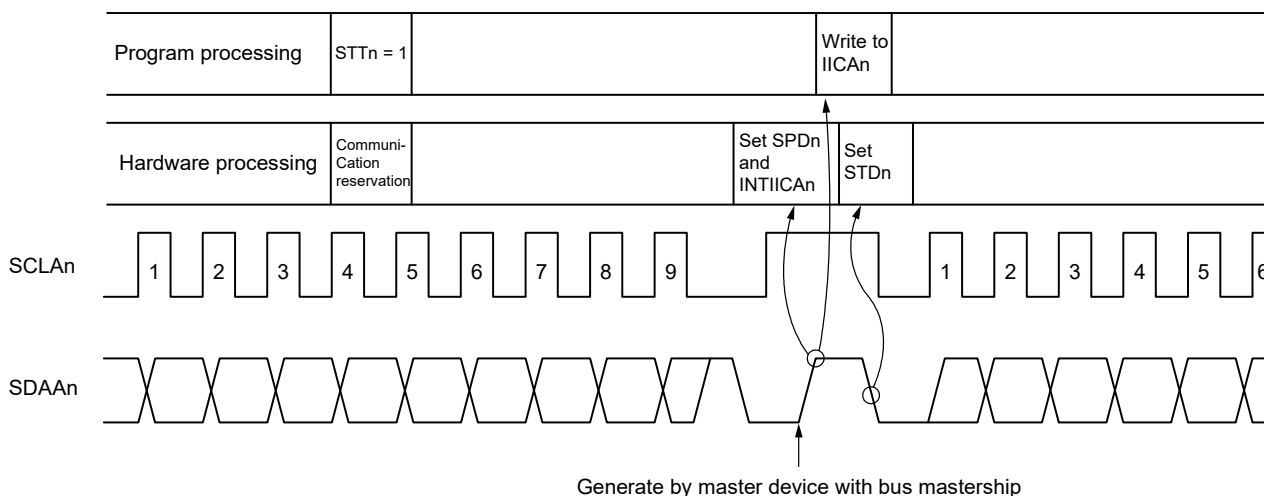

- Remark** IICAn: IICA shift register n
- STTn: Bit 1 of IICA control register n0 (IICCTLn0)
- STDn: Bit 1 of IICA status register n (IICSn)
- SPDn: Bit 0 of IICA status register n (IICSn)

Communication reservations are accepted via the timing shown in Figure 13-26. After bit 1 (STDn) of the IICA status register n (IICSn) is set to 1, a communication reservation can be made by setting bit 1 (STTn) of IICA control register n0 (IICCTLn0) to 1 before a stop condition is detected.

Figure 13-26. Timing for Accepting Communication Reservations

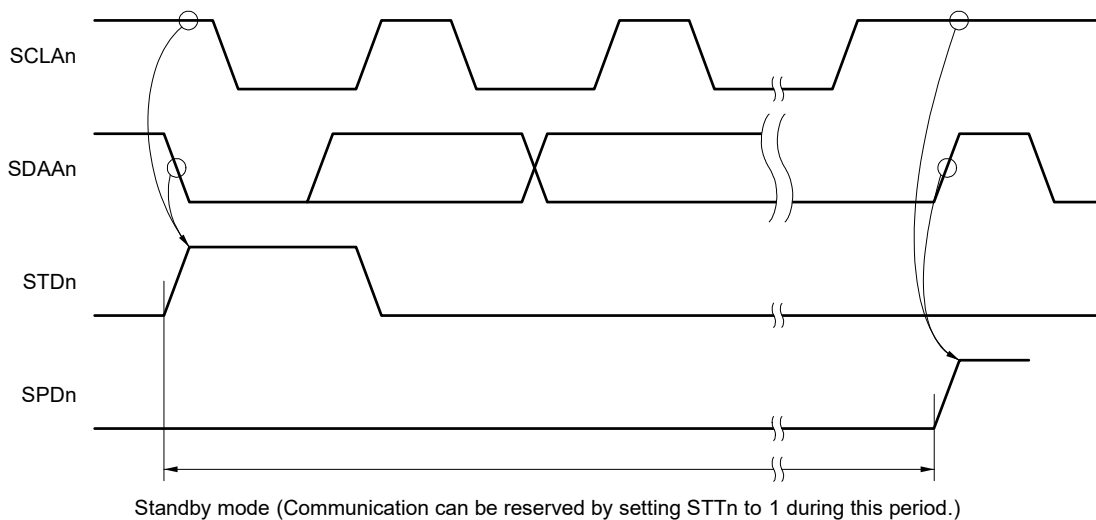
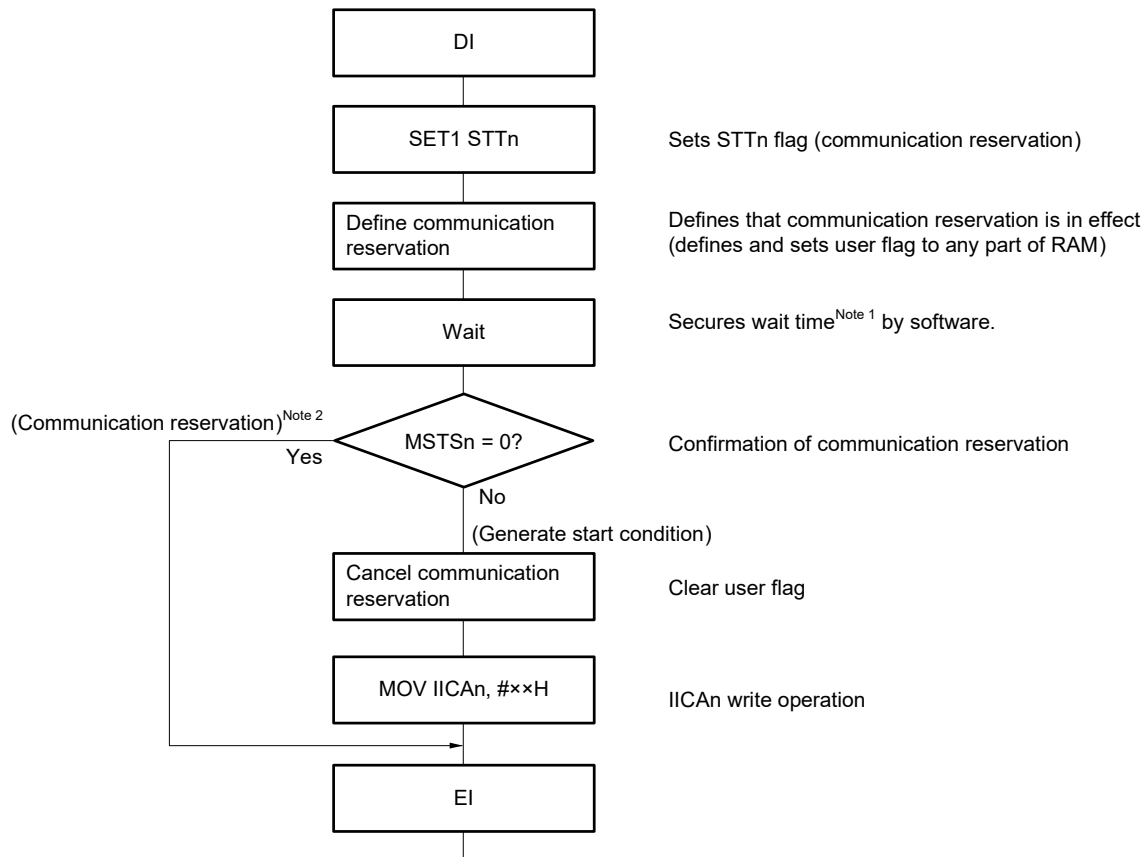

Figure 13-27 shows the communication reservation protocol.

- Remark** n = 0, 1

Figure 13-27. Communication Reservation Protocol



Notes 1. The wait time is calculated as follows.

$$(IICWL_n \text{ setting value} + IICWH_n \text{ setting value} + 4) / f_{MCK} + t_f \times 2$$

- 2.** The communication reservation operation executes a write to the IICA shift register n (IICAn) when a stop condition interrupt request occurs.

Remarks 1. STTn: Bit 1 of IICA control register n0 (IICCTLn0)

MSTSn: Bit 7 of IICA status register n (IICSn)

IICAn: IICA shift register n

IICWLn: IICA low-level width setting register n

IICWHn: IICA high-level width setting register n

t_f: SDAAn and SCLAn signal falling times

f_{MCK}: IICA operation clock frequency

- 2.** n = 0, 1

(2) When communication reservation function is disabled (bit 0 (IICRSVn) of IICA flag register n (IICFn) = 1)

When bit 1 (STTn) of IICA control register n0 (IICCTLn0) is set to 1 when the bus is not used in a communication during bus communication, this request is rejected and a start condition is not generated. The following two statuses are included in the status where bus is not used.

- When arbitration results in neither master nor slave operation
- When an extension code is received and slave operation is disabled (ACK is not returned and the bus was released by setting bit 6 (LRELn) of the IICCTLn0 register to 1 and saving communication)

To confirm whether the start condition was generated or request was rejected, check STCFn (bit 7 of the IICFn register). It takes up to 5 cycles of f_{MCK} until the STCFn bit is set to 1 after setting STTn = 1. Therefore, secure the time by software.

Remark n = 0, 1

13.5.15 Cautions

(1) When STCENn = 0

Immediately after I²C operation is enabled (IICEn = 1), the bus communication status (IICBSYn = 1) is recognized regardless of the actual bus status. When changing from a mode in which no stop condition has been detected to a master device communication mode, first generate a stop condition to release the bus, then perform master device communication.

When using multiple masters, it is not possible to perform master device communication when the bus has not been released (when a stop condition has not been detected).

Use the following sequence for generating a stop condition.

- <1> Set IICA control register n1 (IICCTLn1).
- <2> Set bit 7 (IICEn) of IICA control register n0 (IICCTLn0) to 1.
- <3> Set bit 0 (SPTn) of the IICCTLn0 register to 1.

(2) When STCENn = 1

Immediately after I²C operation is enabled (IICEn = 1), the bus released status (IICBSYn = 0) is recognized regardless of the actual bus status. To generate the first start condition (STTn = 1), it is necessary to confirm that the bus has been released, so as to not disturb other communications.

(3) If other I²C communications are already in progress

If I²C operation is enabled and the device participates in communication already in progress when the SDAAn pin is low and the SCLAn pin is high, the macro of I²C recognizes that the SDAAn pin has gone low (detects a start condition). If the value on the bus at this time can be recognized as an extension code, ACK is returned, but this interferes with other I²C communications. To avoid this, start I²C in the following sequence.

- <1> Clear bit 4 (SPIEn) of the IICCTLn0 register to 0 to disable generation of an interrupt request signal (INTIICAn) when the stop condition is detected.
- <2> Set bit 7 (IICEn) of the IICCTLn0 register to 1 to enable the operation of I²C.
- <3> Wait for detection of the start condition.
- <4> Set bit 6 (LRELn) of the IICCTLn0 register to 1 before ACK is returned (4 to 72 cycles of f_{MCK} after setting the IICEn bit to 1), to forcibly disable detection.

(4) Setting the STTn and SPTn bits (bits 1 and 0 of the IICCTLn0 register) again after they are set and before they are cleared to 0 is prohibited.

(5) When transmission is reserved, set the SPIEn bit (bit 4 of the IICCTLn0 register) to 1 so that an interrupt request is generated when the stop condition is detected. Transfer is started when communication data is written to the IICA shift register n (IICAn) after the interrupt request is generated. Unless the interrupt is generated when the stop condition is detected, the device stops in the wait state because the interrupt request is not generated when communication is started. However, it is not necessary to set the SPIEn bit to 1 when the MSTSn bit (bit 7 of the IICA status register n (IICSn)) is detected by software.

Remark n = 0, 1

13.5.16 Communication operations

The following shows three operation procedures with the flowchart.

(1) Master operation in single master system

The flowchart when using the RL78/G13 as the master in a single master system is shown below.

This flowchart is broadly divided into the initial settings and communication processing. Execute the initial settings at startup. If communication with the slave is required, prepare the communication and then execute communication processing.

(2) Master operation in multimaster system

In the I²C bus multimaster system, whether the bus is released or used cannot be judged by the I²C bus specifications when the bus takes part in a communication. Here, when data and clock are at a high level for a certain period (1 frame), the RL78/G13 takes part in a communication with bus released state.

This flowchart is broadly divided into the initial settings, communication waiting, and communication processing. The processing when the RL78/G13 loses in arbitration and is specified as the slave is omitted here, and only the processing as the master is shown. Execute the initial settings at startup to take part in a communication. Then, wait for the communication request as the master or wait for the specification as the slave. The actual communication is performed in the communication processing, and it supports the transmission/reception with the slave and the arbitration with other masters.

(3) Slave operation

An example of when the RL78/G13 is used as the I²C bus slave is shown below.

When used as the slave, operation is started by an interrupt. Execute the initial settings at startup, then wait for the INTIICAn interrupt occurrence (communication waiting). When an INTIICAn interrupt occurs, the communication status is judged and its result is passed as a flag over to the main processing.

By checking the flags, necessary communication processing is performed.

Remark n = 0, 1

(1) Master operation in single-master system

Figure 13-28. Master Operation in Single-Master System

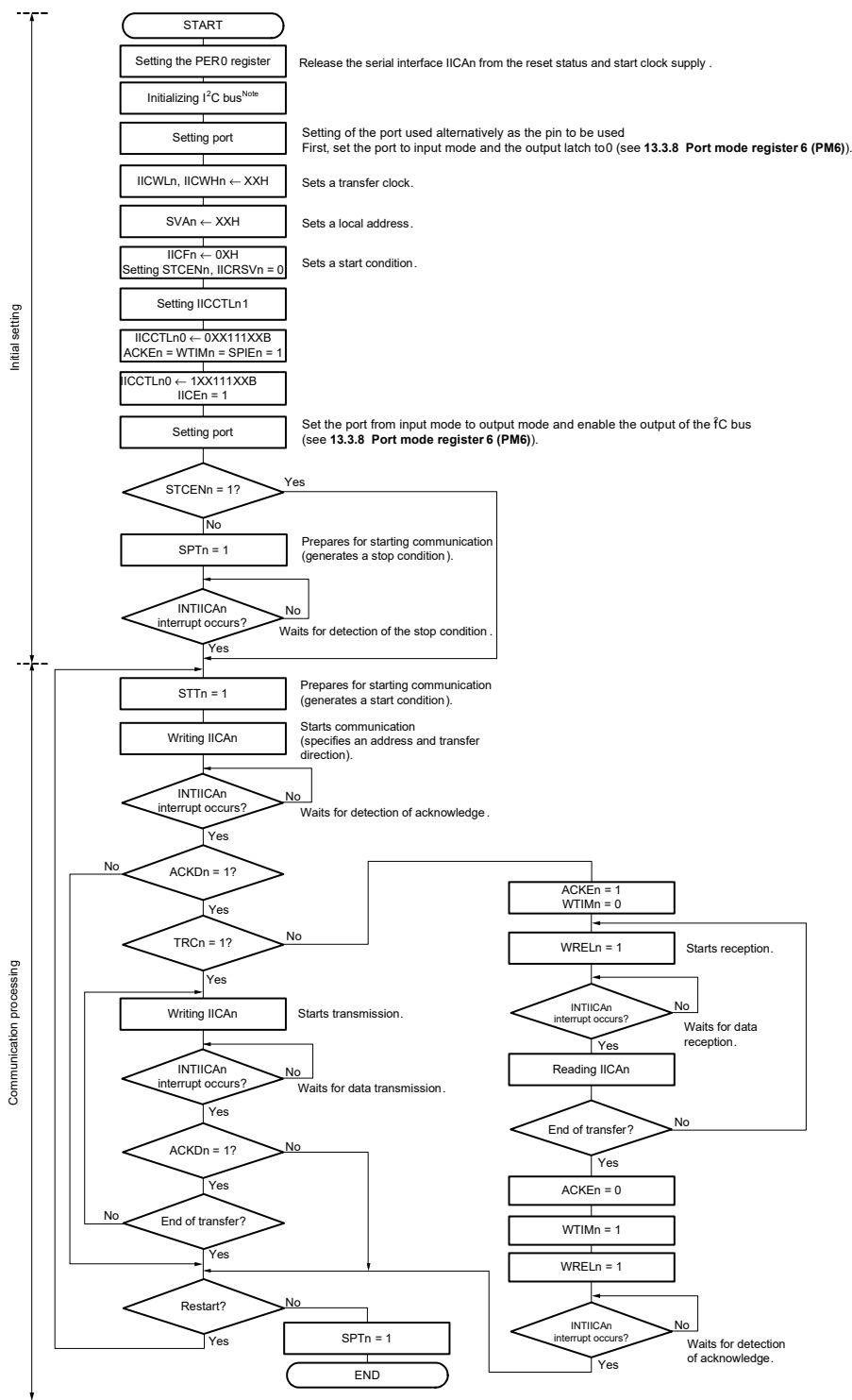

Note Release (SCLAn and SDAAn pins = high level) the I²C bus in conformance with the specifications of the product that is communicating. If EEPROM is outputting a low level to the SDAAn pin, for example, set the SCLAn pin in the output port mode, and output a clock pulse from the output port until the SDAAn pin is constantly at high level.

Remarks 1. Conform to the specifications of the product that is communicating, with respect to the transmission and reception formats.

2. n = 0, 1

(2) Master operation in multi-master system

Figure 13-29. Master Operation in Multi-Master System (1/3)

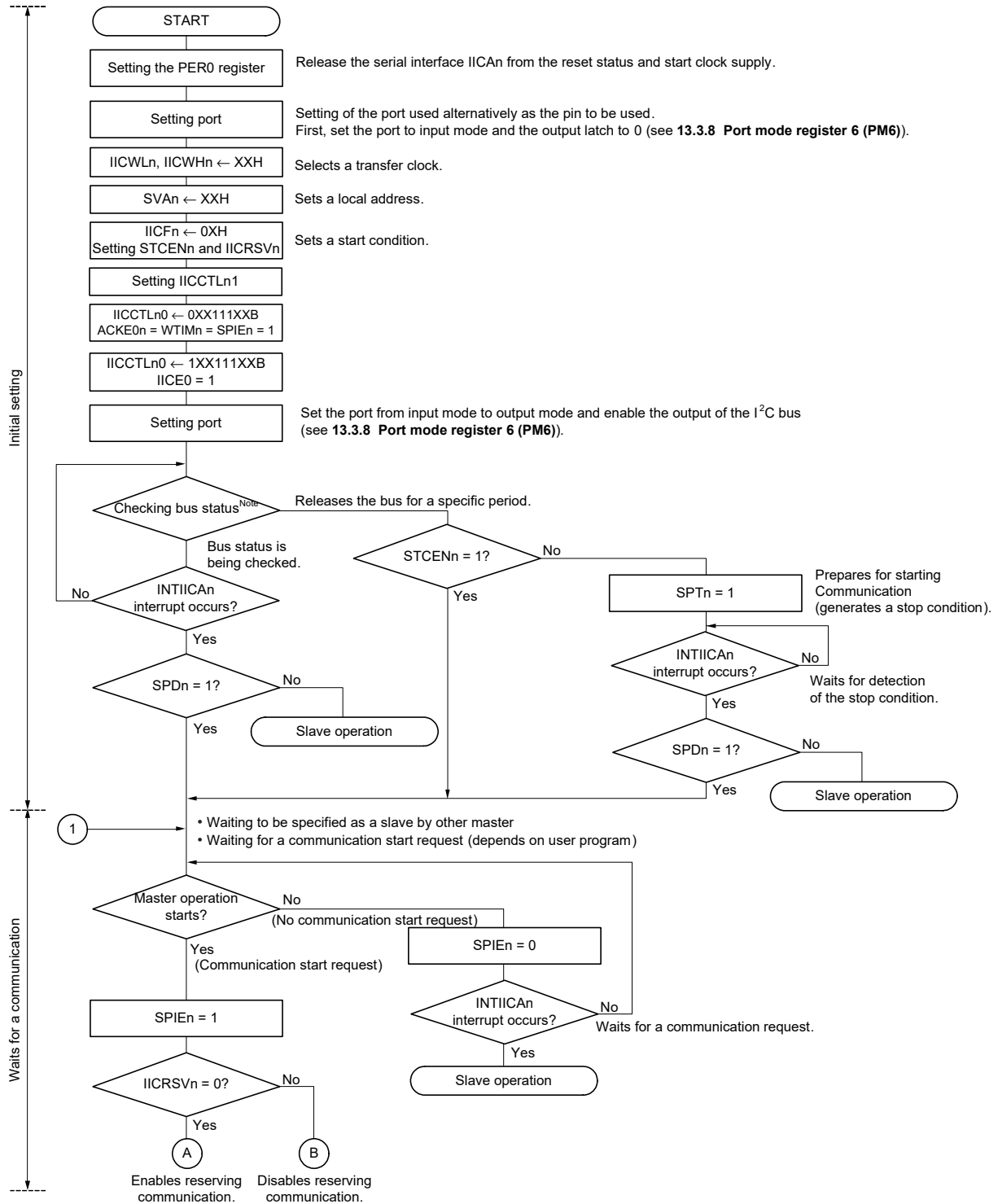

Note Confirm that the bus is released (CLDn bit = 1, DADn bit = 1) for a specific period (for example, for a period of one frame). If the SDAAn pin is constantly at low level, decide whether to release the I²C bus (SCLAn and SDAAn pins = high level) in conformance with the specifications of the product that is communicating.

Remark n = 0, 1

Figure 13-29. Master Operation in Multi-Master System (2/3)

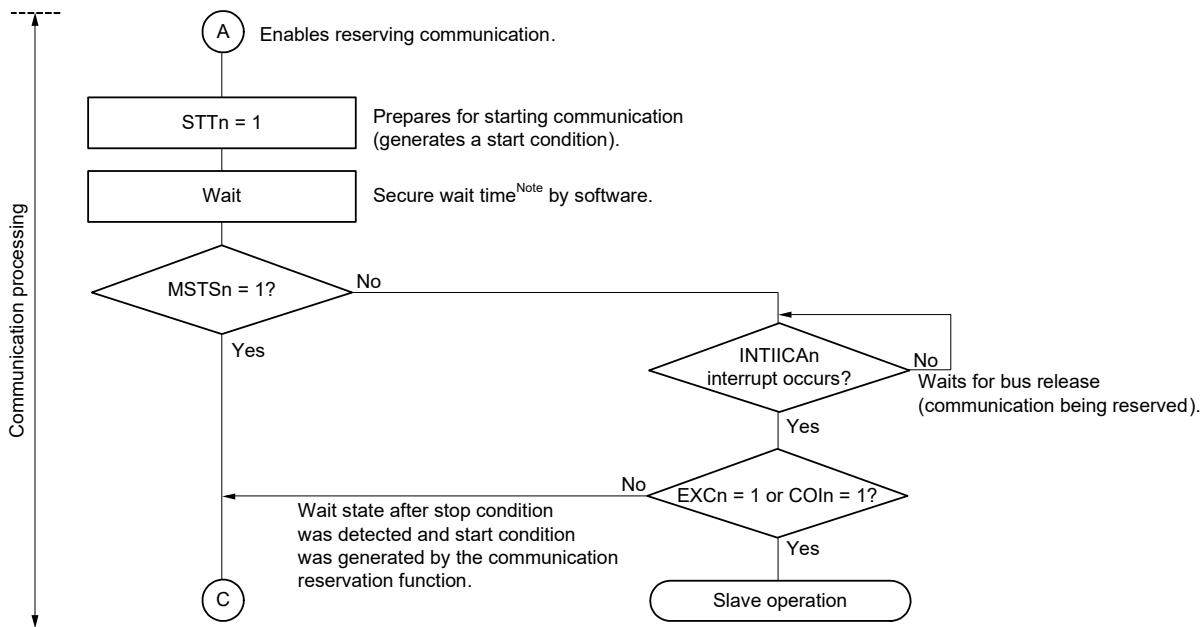

Note The wait time is calculated as follows.
 $(IICWLn \text{ setting value} + IICWHn \text{ setting value} + 4) / f_{MCK} + t_F \times 2$

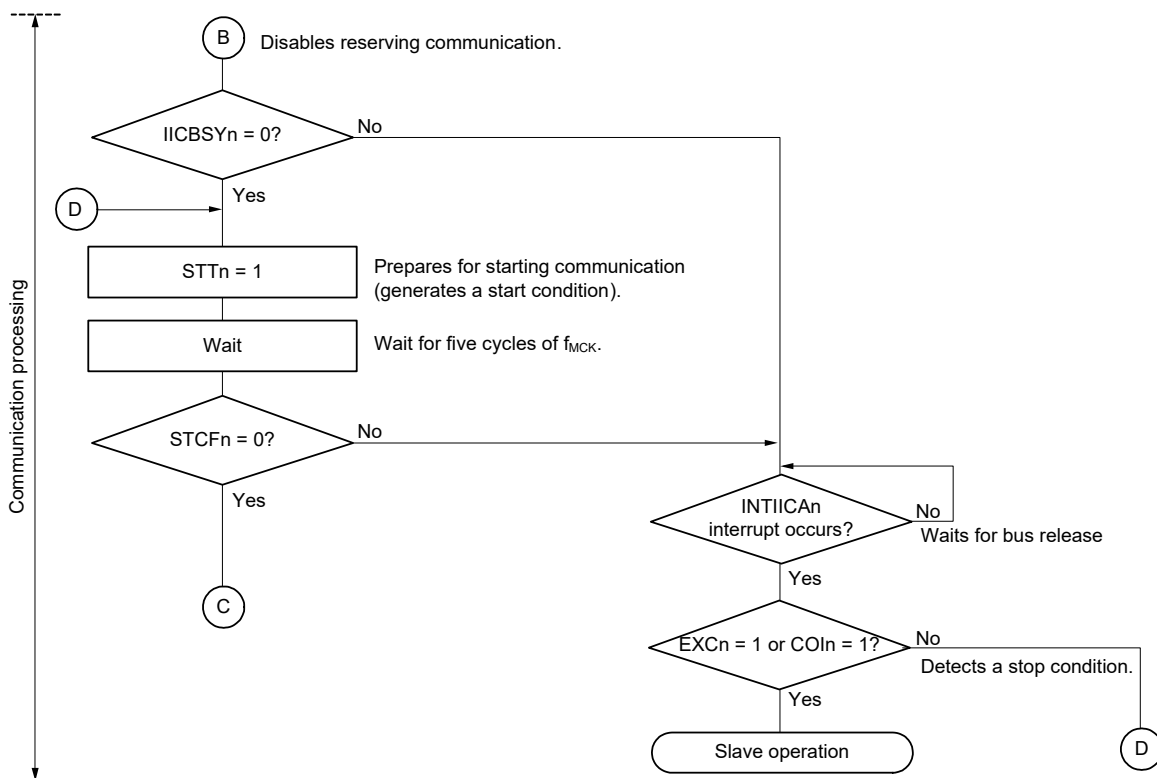

- Remarks 1.** IICWLn: IICA low-level width setting register n
 IICWHn: IICA high-level width setting register n
 t_F: SDAAn and SCLAn signal falling times
 f_{MCK}: IICA operation clock frequency
- 2.** n = 0, 1

Figure 13-29. Master Operation in Multi-Master System (3/3)

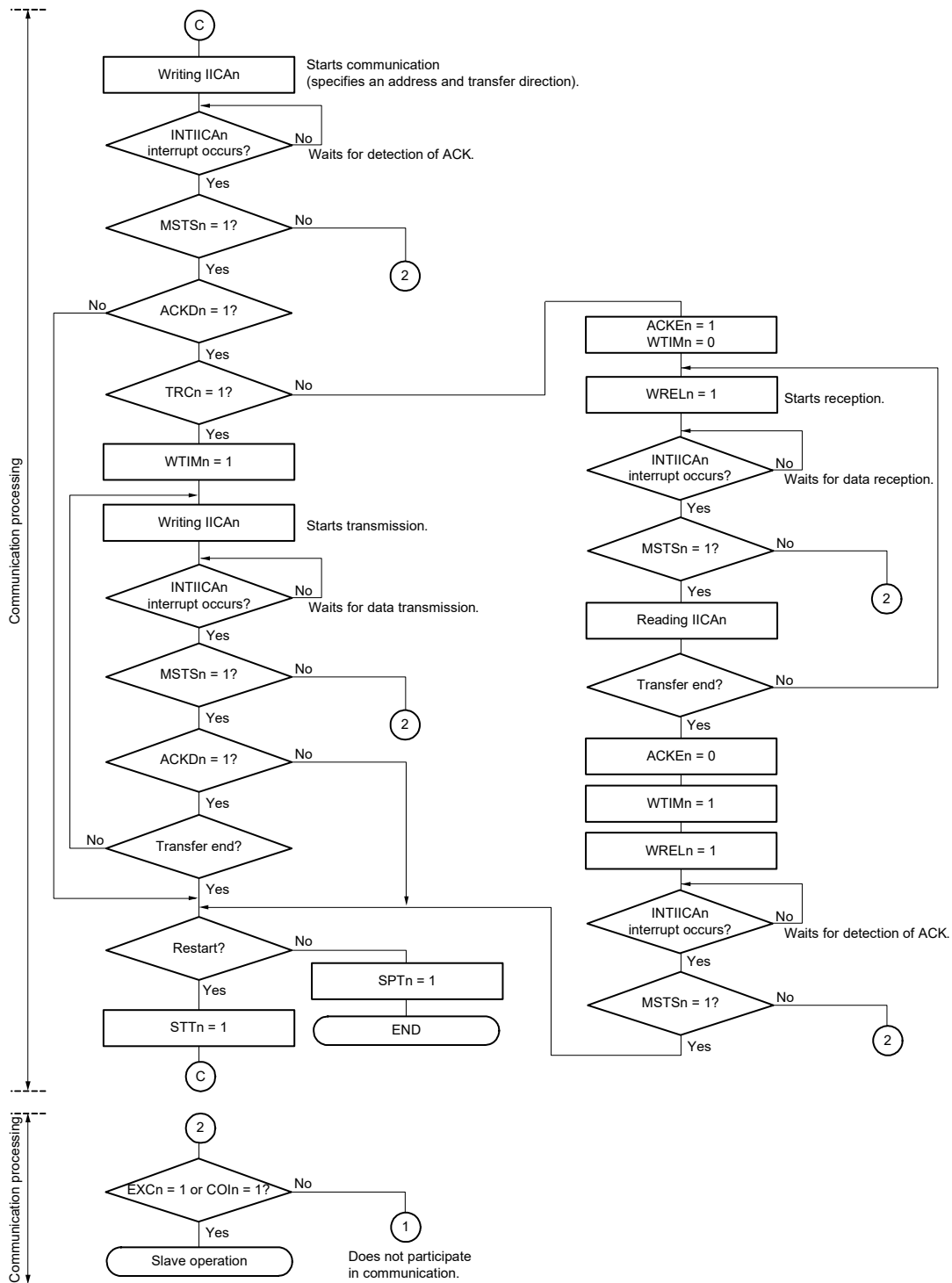

- Remarks**
1. Conform to the specifications of the product that is communicating, with respect to the transmission and reception formats.
 2. To use the device as a master in a multi-master system, read the MSTSn bit each time interrupt INTIICAn has occurred to check the arbitration result.
 3. To use the device as a slave in a multi-master system, check the status by using the IICA status register n (IICSn) and IICA flag register n (IICFn) each time interrupt INTIICAn has occurred, and determine the processing to be performed next.
 4. n = 0, 1

(3) Slave operation

The processing procedure of the slave operation is as follows.

Basically, the slave operation is event-driven. Therefore, processing by the INTIICAn interrupt (processing that must substantially change the operation status such as detection of a stop condition during communication) is necessary.

In the following explanation, it is assumed that the extension code is not supported for data communication. It is also assumed that the INTIICAn interrupt servicing only performs status transition processing, and that actual data communication is performed by the main processing.

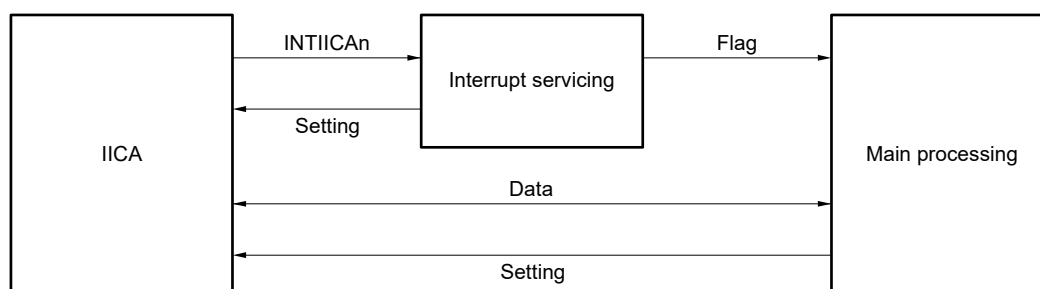

Therefore, data communication processing is performed by preparing the following three flags and passing them to the main processing instead of INTIICAn.

<1> Communication mode flag

This flag indicates the following two communication statuses.

- Clear mode: Status in which data communication is not performed
- Communication mode: Status in which data communication is performed (from valid address detection to stop condition detection, no detection of ACK from master, address mismatch)

<2> Ready flag

This flag indicates that data communication is enabled. Its function is the same as the INTIICAn interrupt for ordinary data communication. This flag is set by interrupt servicing and cleared by the main processing. Clear this flag by interrupt servicing when communication is started. However, the ready flag is not set by interrupt servicing when the first data is transmitted. Therefore, the first data is transmitted without the flag being cleared (an address match is interpreted as a request for the next data).

<3> Communication direction flag

This flag indicates the direction of communication. Its value is the same as the TRCn bit.

Remark n = 0, 1

The main processing of the slave operation is explained next.

Start serial interface IICA and wait until communication is enabled. When communication is enabled, execute communication by using the communication mode flag and ready flag (processing of the stop condition and start condition is performed by an interrupt. Here, check the status by using the flags).

The transmission operation is repeated until the master no longer returns ACK. If ACK is not returned from the master, communication is completed.

For reception, the necessary amount of data is received. When communication is completed, ACK is not returned as the next data. After that, the master generates a stop condition or restart condition. Exit from the communication status occurs in this way.

Figure 13-30. Slave Operation Flowchart (1)

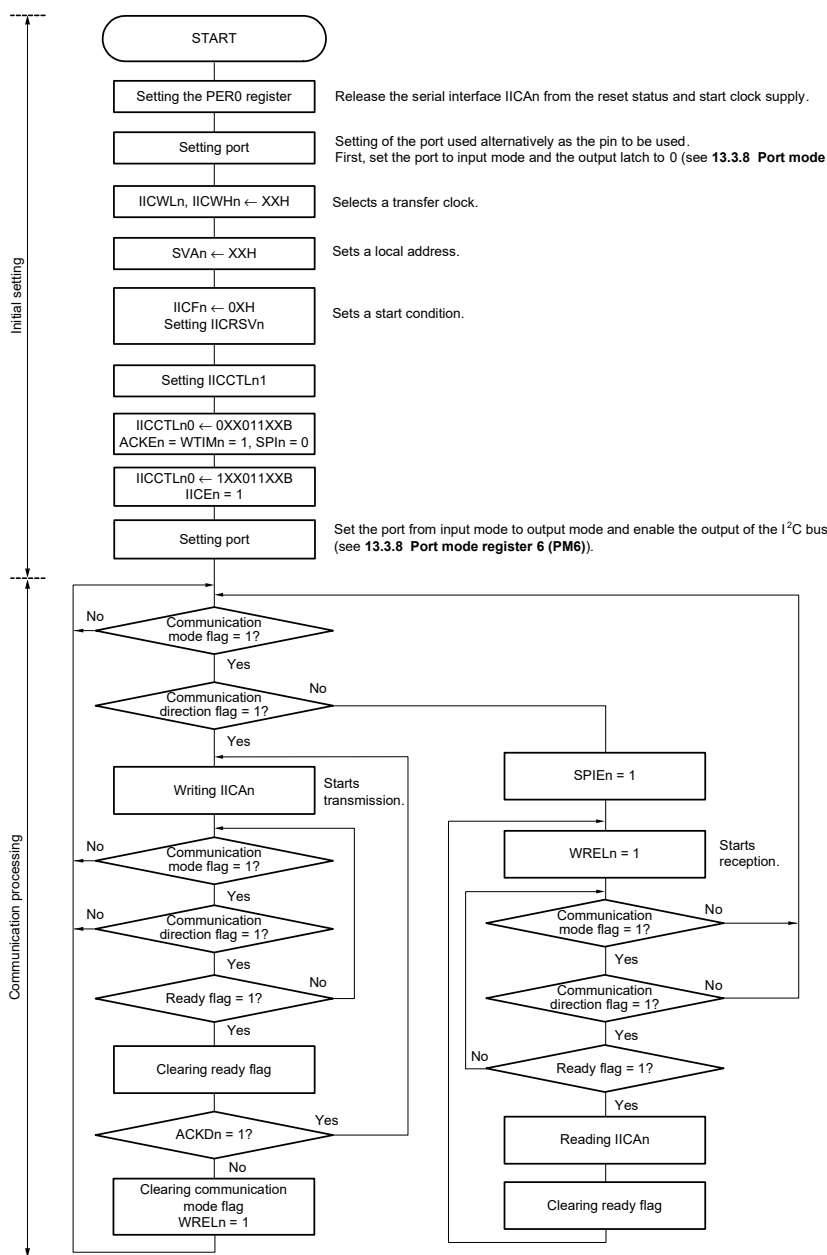

Remarks 1. Conform to the specifications of the product that is in communication, regarding the transmission and reception formats.

2. n = 0, 1

An example of the processing procedure of the slave with the INTIICAn interrupt is explained below (processing is performed assuming that no extension code is used). The INTIICAn interrupt checks the status, and the following operations are performed.

- <1> Communication is stopped if the stop condition is issued.
- <2> If the start condition is issued, the address is checked and communication is completed if the address does not match. If the address matches, the communication mode is set, wait is cancelled, and processing returns from the interrupt (the ready flag is cleared).
- <3> For data transmit/receive, only the ready flag is set. Processing returns from the interrupt with the I²C bus remaining in the wait state.

Remark <1> to <3> above correspond to <1> to <3> in Figure 13-31 Slave Operation Flowchart (2).

Figure 13-31. Slave Operation Flowchart (2)

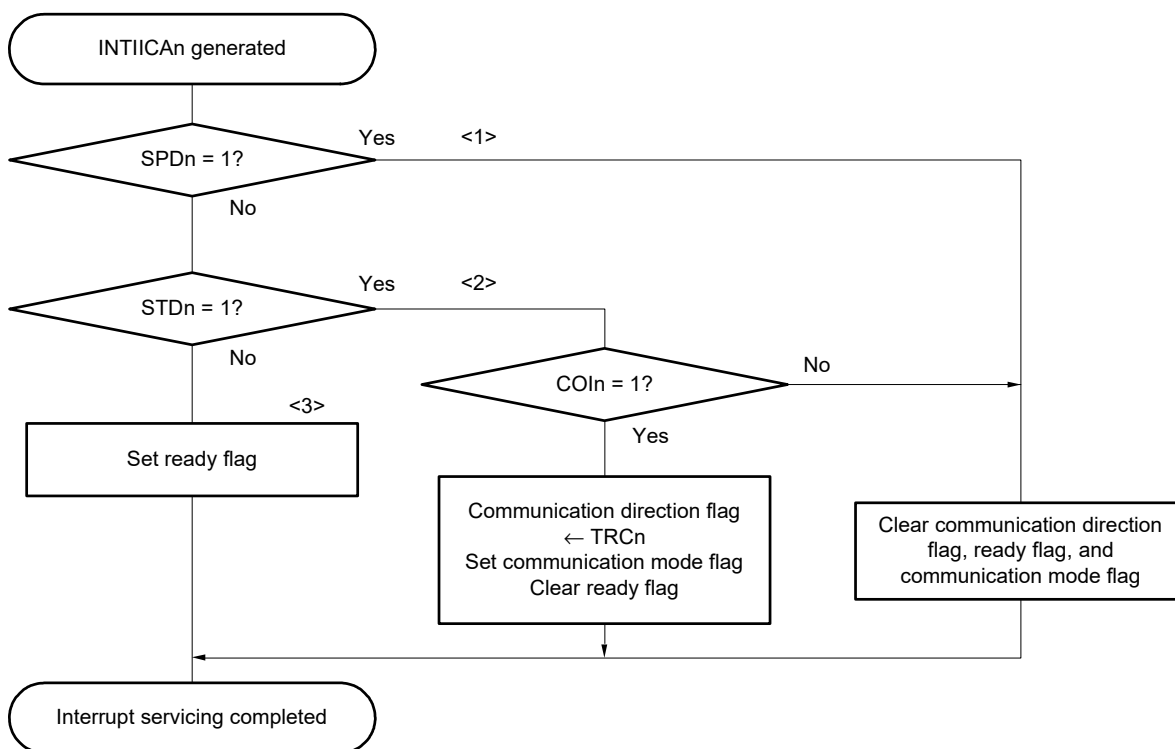

13.5.17 Timing of I²C interrupt request (INTIICAn) occurrence

The timing of transmitting or receiving data and generation of interrupt request signal INTIICAn, and the value of the IICA status register n (IICSn) when the INTIICAn signal is generated are shown below.

- Remarks 1.**
- ST: Start condition
 - AD6 to AD0: Address
 - R \bar{W} : Transfer direction specification
 - ACK: Acknowledge
 - D7 to D0: Data
 - SP: Stop condition
- 2.** n = 0, 1

(1) Master device operation

(a) Start ~ Address ~ Data ~ Data ~ Stop (transmission/reception)

(i) When WTIMn = 0

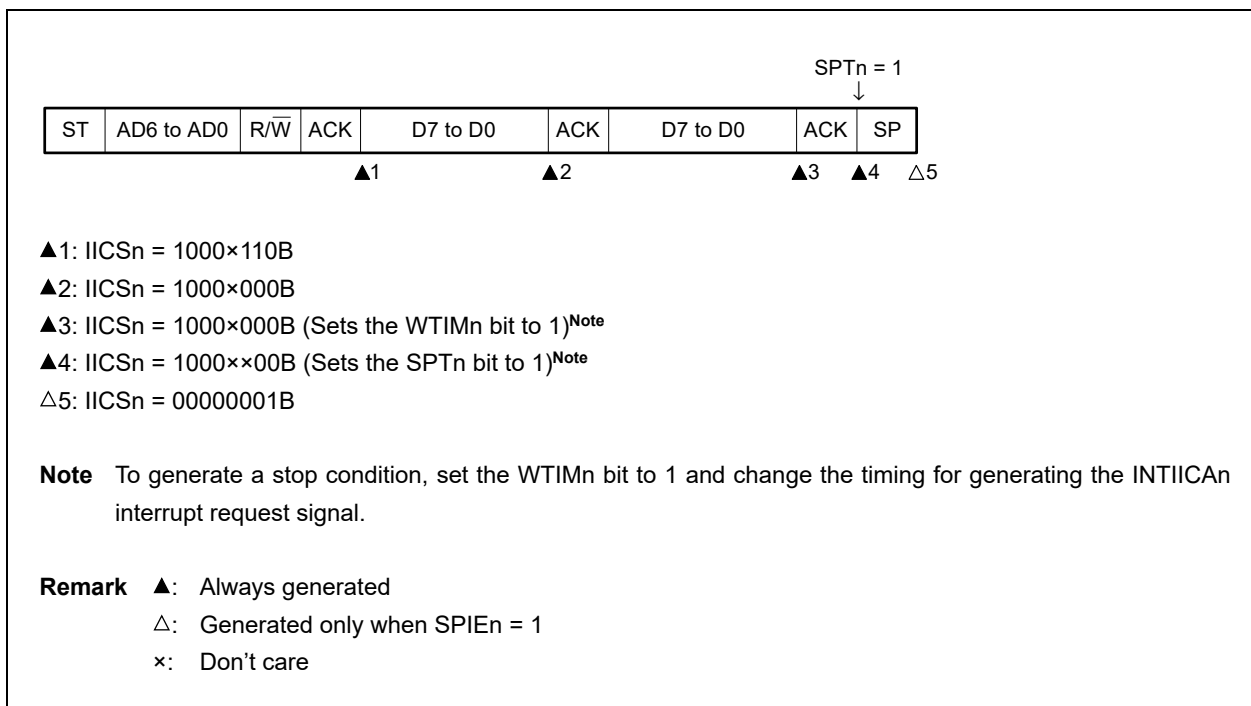

(ii) When WTIMn = 1

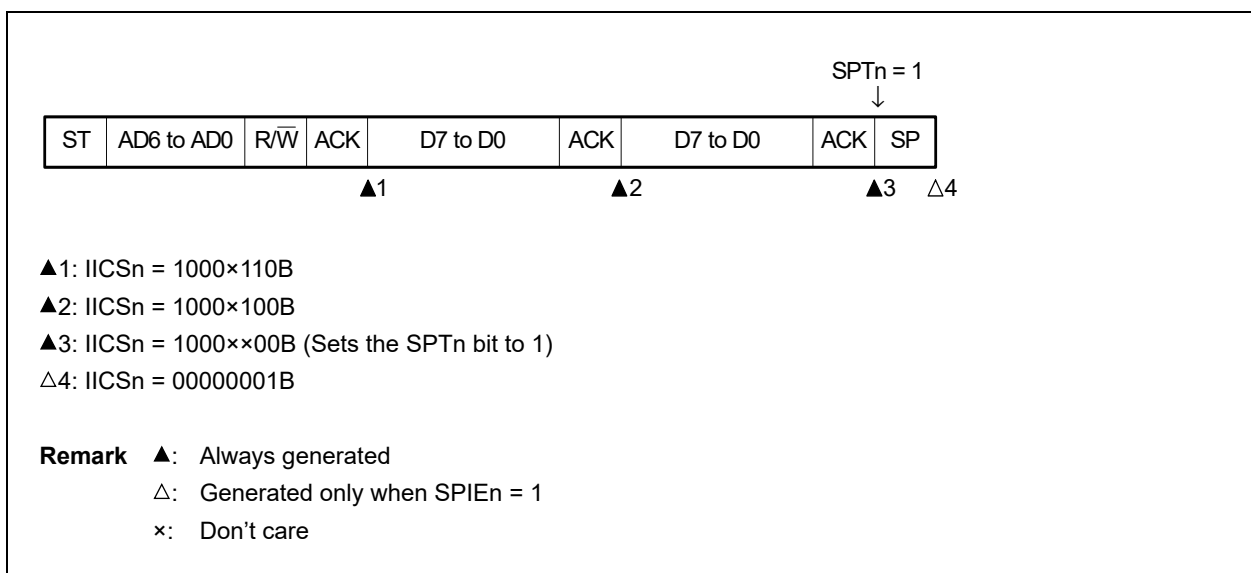

Remark n = 0, 1

(b) Start ~ Address ~ Data ~ Start ~ Address ~ Data ~ Stop (restart)

(i) When WTIMn = 0

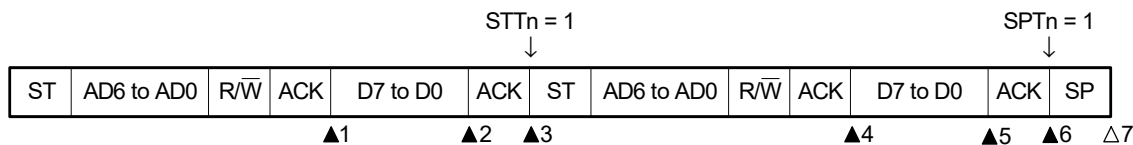

- ▲1: IICSn = 1000×110B
- ▲2: IICSn = 1000×000B (Sets the WTIMn bit to 1)^{Note 1}
- ▲3: IICSn = 1000××00B (Clears the WTIMn bit to 0^{Note 2}, sets the STTn bit to 1)
- ▲4: IICSn = 1000×110B
- ▲5: IICSn = 1000×000B (Sets the WTIMn bit to 1)^{Note 3}
- ▲6: IICSn = 1000××00B (Sets the SPTn bit to 1)
- Δ7: IICSn = 00000001B

- Notes**
1. To generate a start condition, set the WTIMn bit to 1 and change the timing for generating the INTIICAn interrupt request signal.
 2. Clear the WTIMn bit to 0 to restore the original setting.
 3. To generate a stop condition, set the WTIMn bit to 1 and change the timing for generating the INTIICAn interrupt request signal.

Remark

- ▲: Always generated
- Δ: Generated only when SPIEn = 1
- ×: Don't care

(ii) When WTIMn = 1

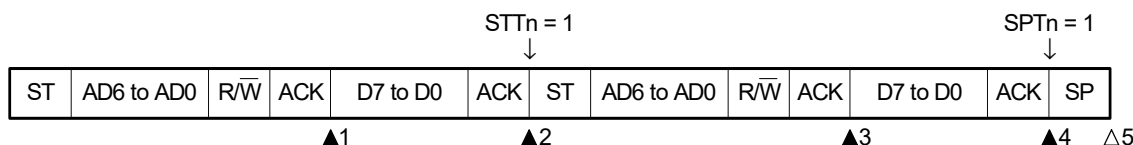

- ▲1: IICSn = 1000×110B
- ▲2: IICSn = 1000××00B (Sets the STTn bit to 1)
- ▲3: IICSn = 1000×110B
- ▲4: IICSn = 1000××00B (Sets the SPTn bit to 1)
- Δ5: IICSn = 00000001B

Remark

- ▲: Always generated
- Δ: Generated only when SPIEn = 1
- ×: Don't care

Remark n = 0, 1

(c) Start ~ Code ~ Data ~ Data ~ Stop (extension code transmission)

(i) When WTIMn = 0

▲1: IICSn = 1010×110B
 ▲2: IICSn = 1010×000B
 ▲3: IICSn = 1010×000B (Sets the WTIMn bit to 1)^{Note}
 ▲4: IICSn = 1010××00B (Sets the SPTn bit to 1)
 Δ5: IICSn = 00000001B

Note To generate a stop condition, set the WTIMn bit to 1 and change the timing for generating the INTIICAn interrupt request signal.

Remark ▲: Always generated
 Δ: Generated only when SPIEn = 1
 ×: Don't care

(ii) When WTIMn = 1

▲1: IICSn = 1010×110B
 ▲2: IICSn = 1010×100B
 ▲3: IICSn = 1010××00B (Sets the SPTn bit to 1)
 Δ4: IICSn = 00000001B

Remark ▲: Always generated
 Δ: Generated only when SPIEn = 1
 ×: Don't care

Remark n = 0, 1

(2) Slave device operation (slave address data reception)

(a) Start ~ Address ~ Data ~ Data ~ Stop

(i) When WTIMn = 0

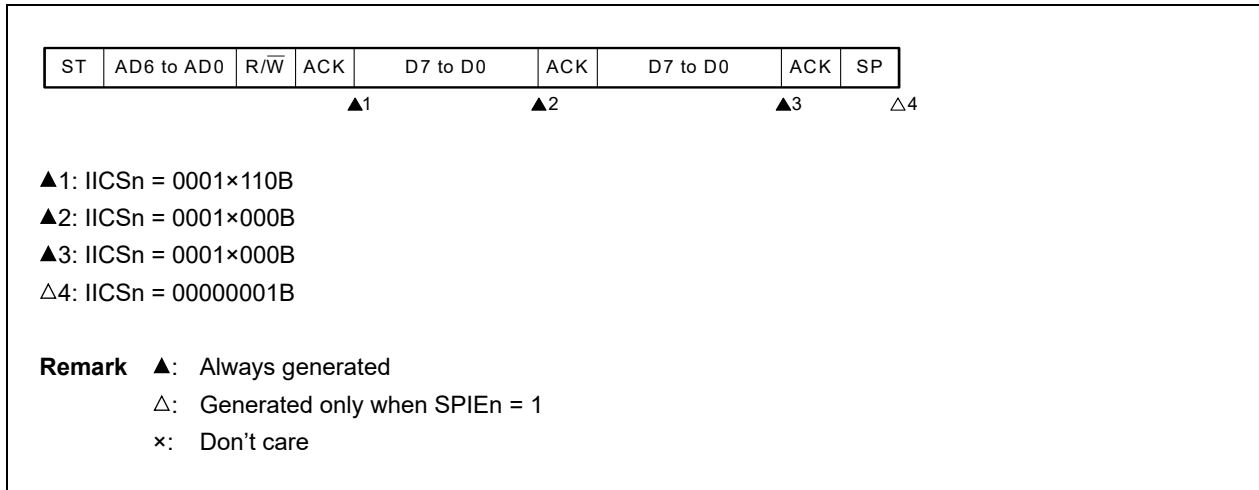

(ii) When WTIMn = 1

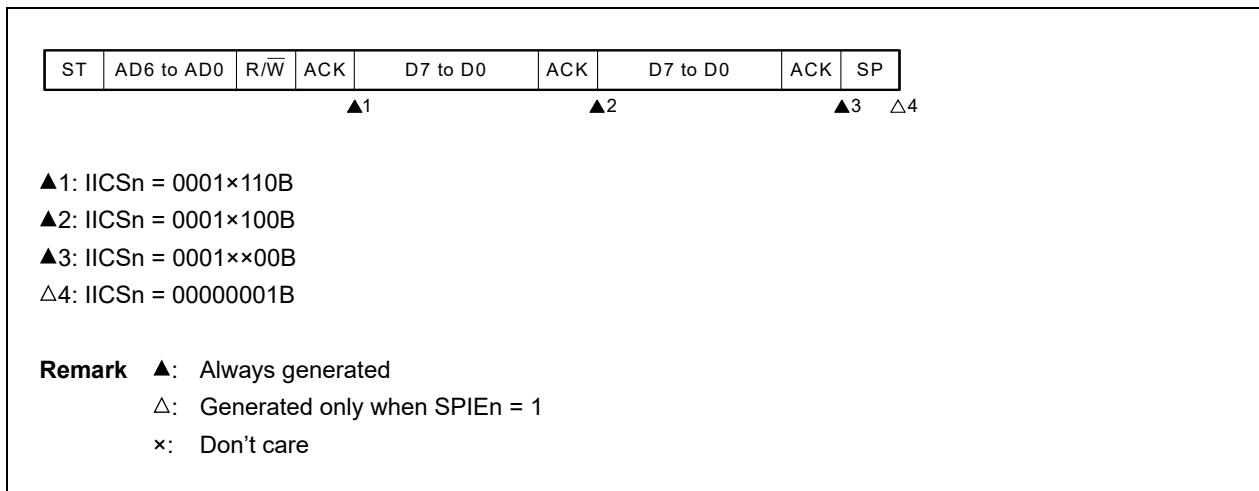

Remark n = 0, 1

(b) Start ~ Address ~ Data ~ Start ~ Address ~ Data ~ Stop

(i) When WTIMn = 0 (after restart, matches with SVAn)

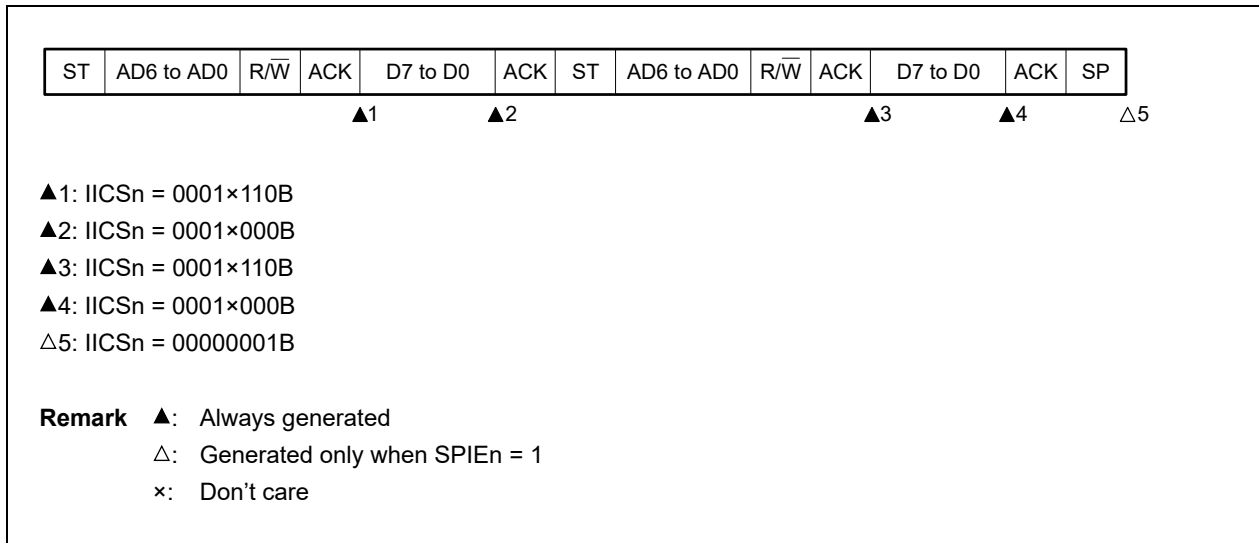

(ii) When WTIMn = 1 (after restart, matches with SVAn)

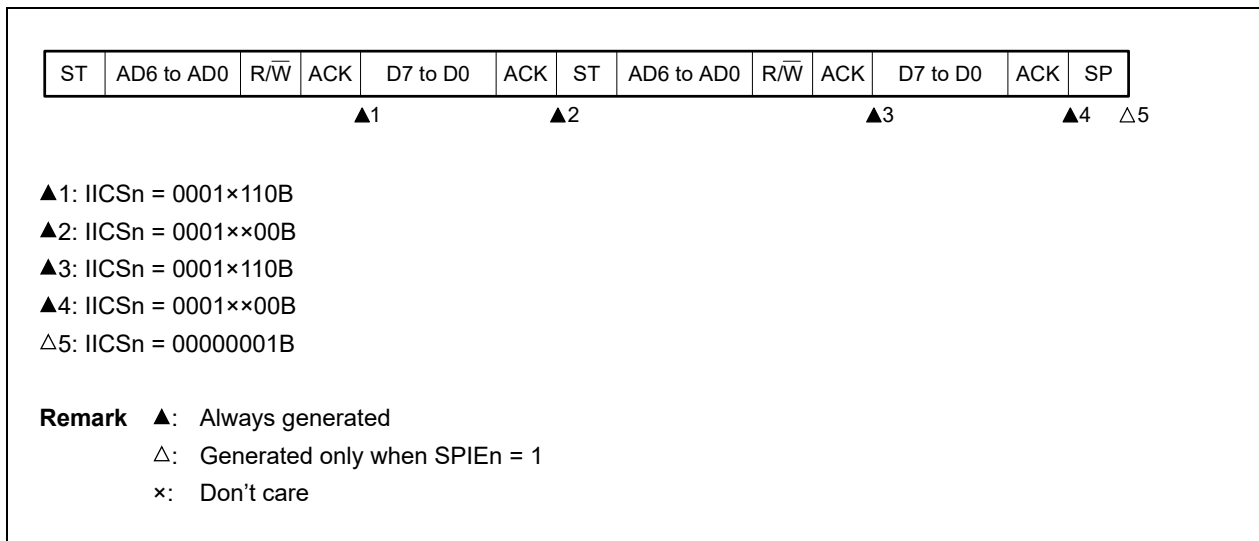

Remark n = 0, 1

(c) Start ~ Address ~ Data ~ Start ~ Code ~ Data ~ Stop

(i) When WTIMn = 0 (after restart, does not match address (= extension code))

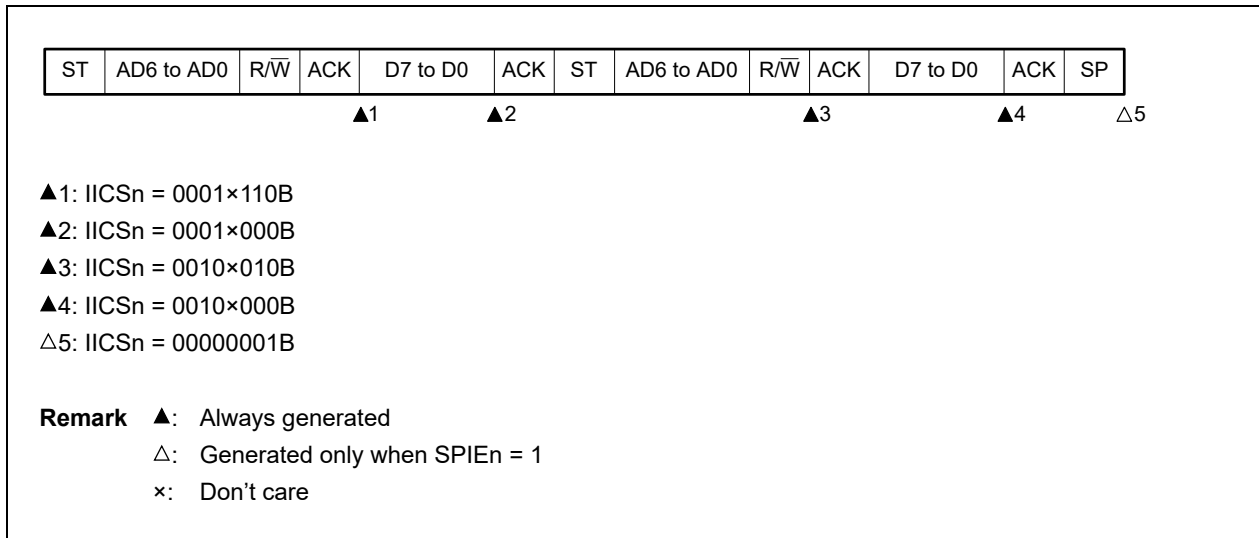

(ii) When WTIMn = 1 (after restart, does not match address (= extension code))

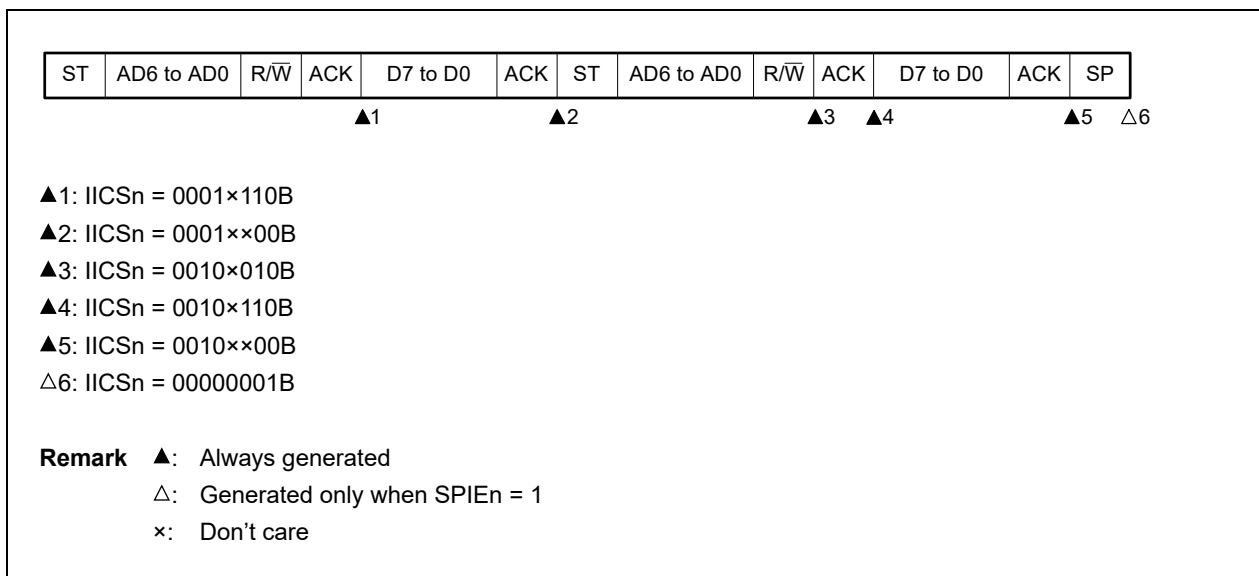

Remark n = 0, 1

(d) Start ~ Address ~ Data ~ Start ~ Address ~ Data ~ Stop

(i) When WTIMn = 0 (after restart, does not match address (= not extension code))

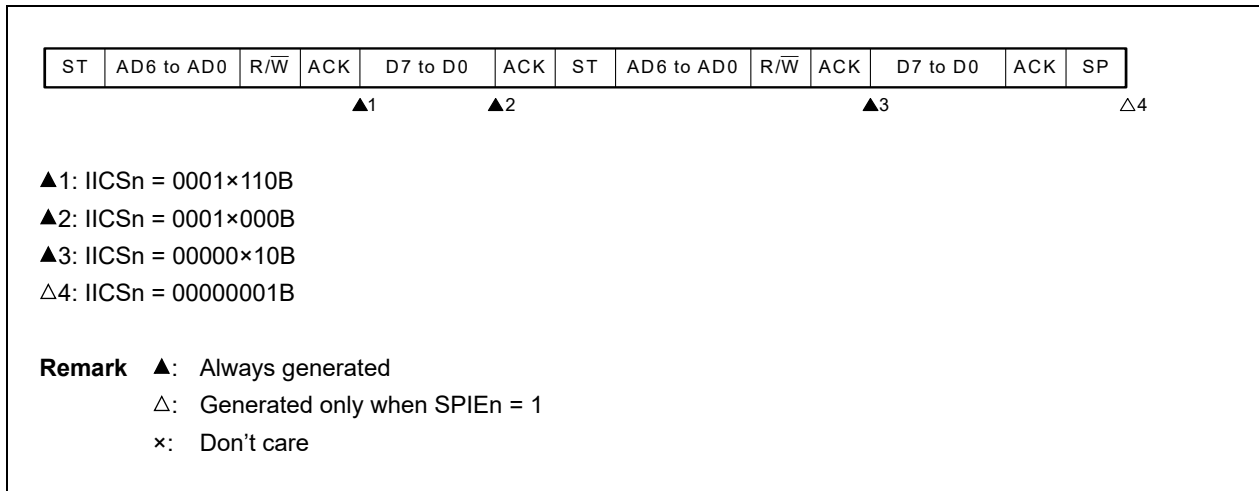

(ii) When WTIMn = 1 (after restart, does not match address (= not extension code))

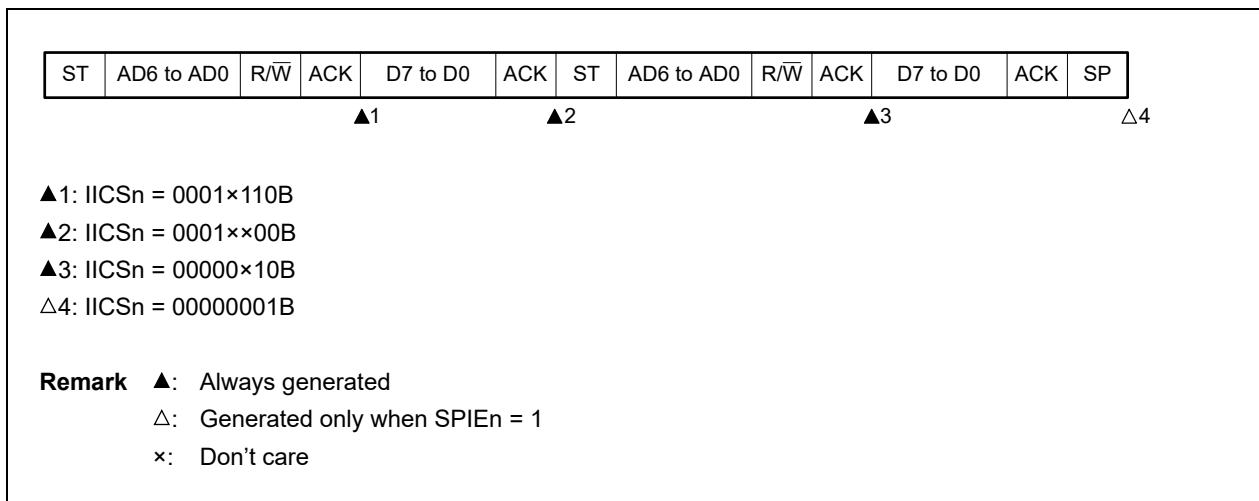

Remark n = 0, 1

(3) Slave device operation (when receiving extension code)

The device is always participating in communication when it receives an extension code.

(a) Start ~ Code ~ Data ~ Data ~ Stop

(i) When WTIMn = 0

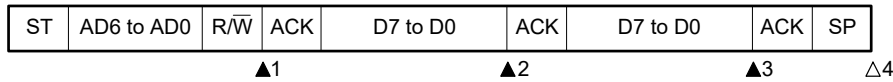

▲1: IICSn = 0010×010B

▲2: IICSn = 0010×000B

▲3: IICSn = 0010×000B

△4: IICSn = 00000001B

Remark ▲: Always generated
 △: Generated only when SPIEn = 1
 ×: Don't care

(ii) When WTIMn = 1

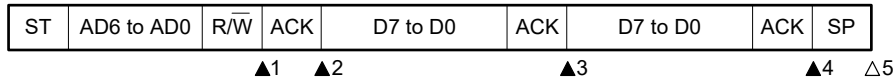

▲1: IICSn = 0010×010B

▲2: IICSn = 0010×110B

▲3: IICSn = 0010×100B

▲4: IICSn = 0010××00B

△5: IICSn = 00000001B

Remark ▲: Always generated
 △: Generated only when SPIEn = 1
 ×: Don't care

Remark n = 0, 1

(b) Start ~ Code ~ Data ~ Start ~ Address ~ Data ~ Stop

(i) When WTIMn = 0 (after restart, matches SVAn)

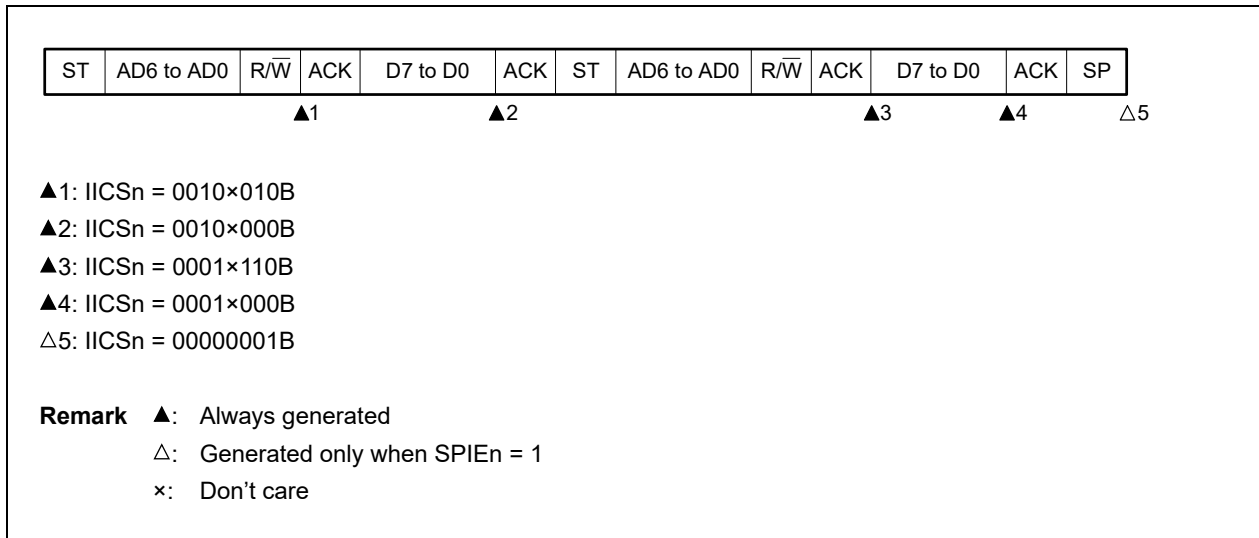

(ii) When WTIMn = 1 (after restart, matches SVAn)

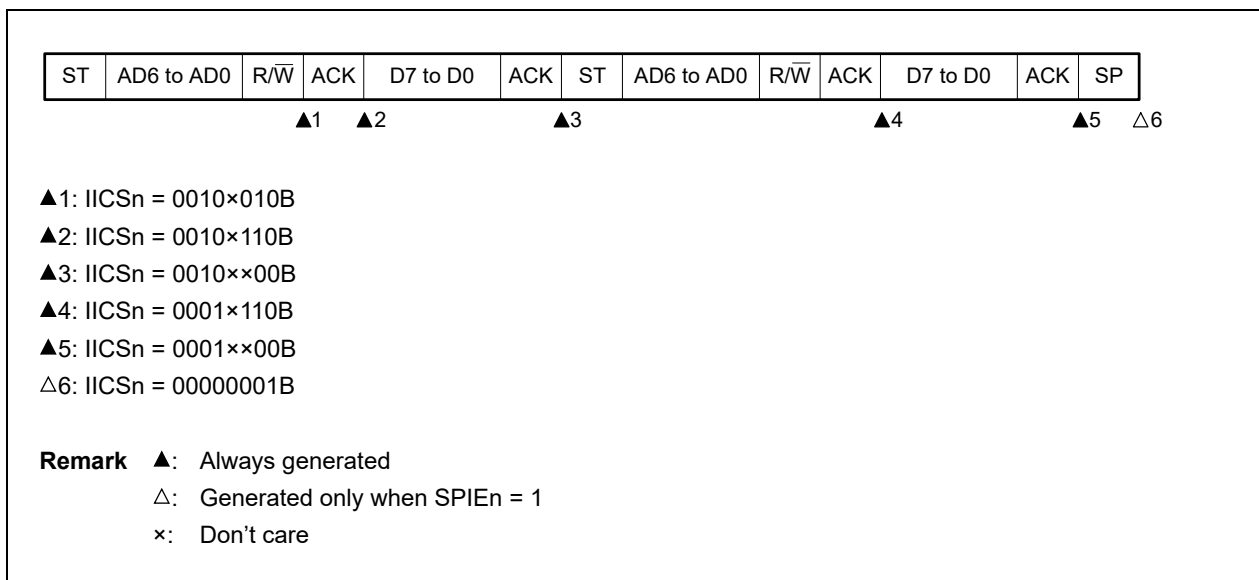

Remark n = 0, 1

(c) Start ~ Code ~ Data ~ Start ~ Code ~ Data ~ Stop

(i) When WTIMn = 0 (after restart, extension code reception)

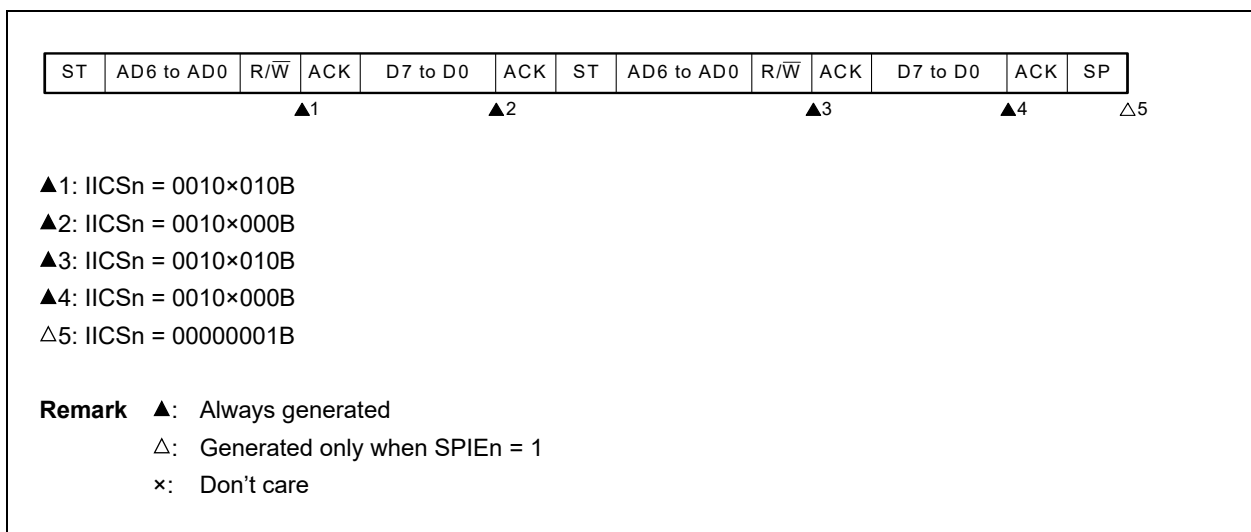

(ii) When WTIMn = 1 (after restart, extension code reception)

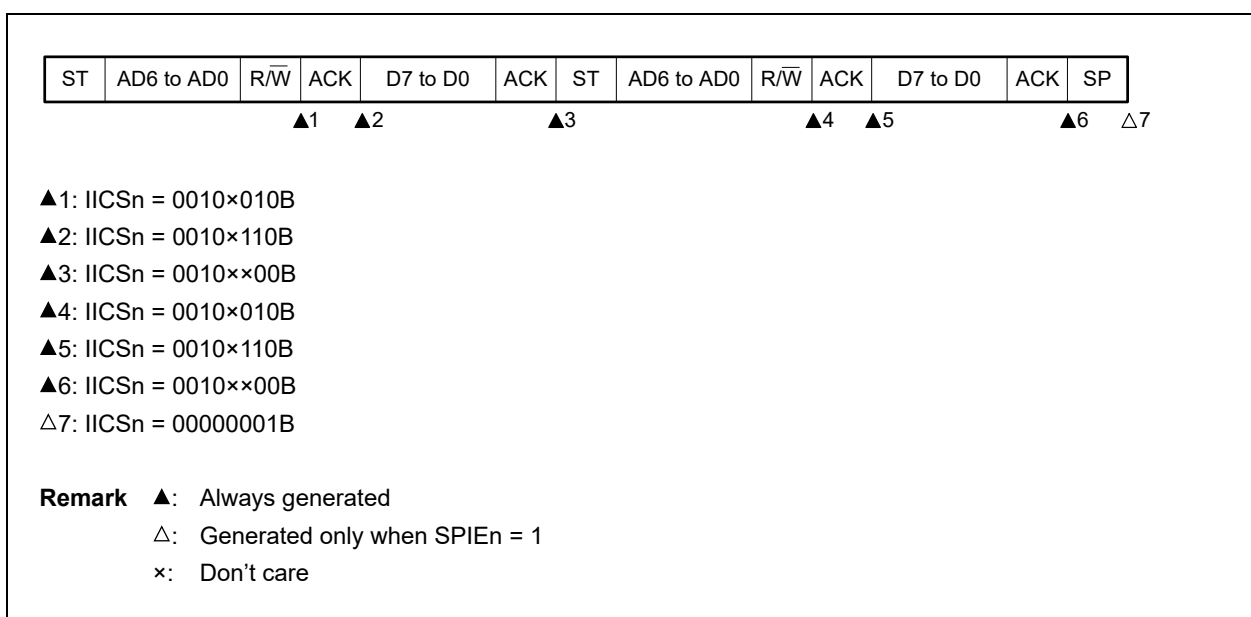

Remark n = 0, 1

(d) Start ~ Code ~ Data ~ Start ~ Address ~ Data ~ Stop

(i) When WTIMn = 0 (after restart, does not match address (= not extension code))

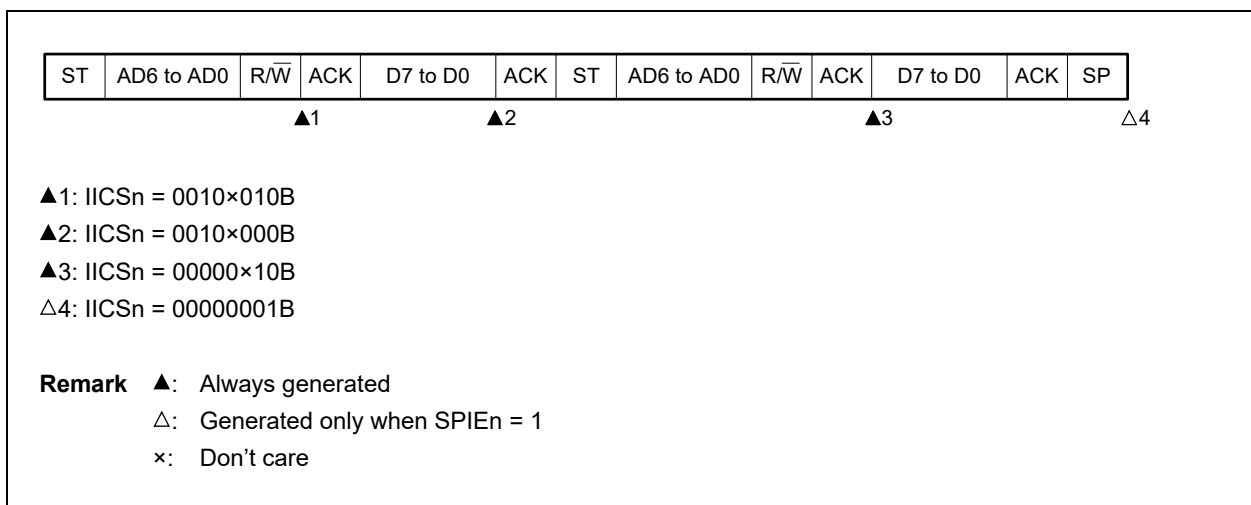

(ii) When WTIMn = 1 (after restart, does not match address (= not extension code))

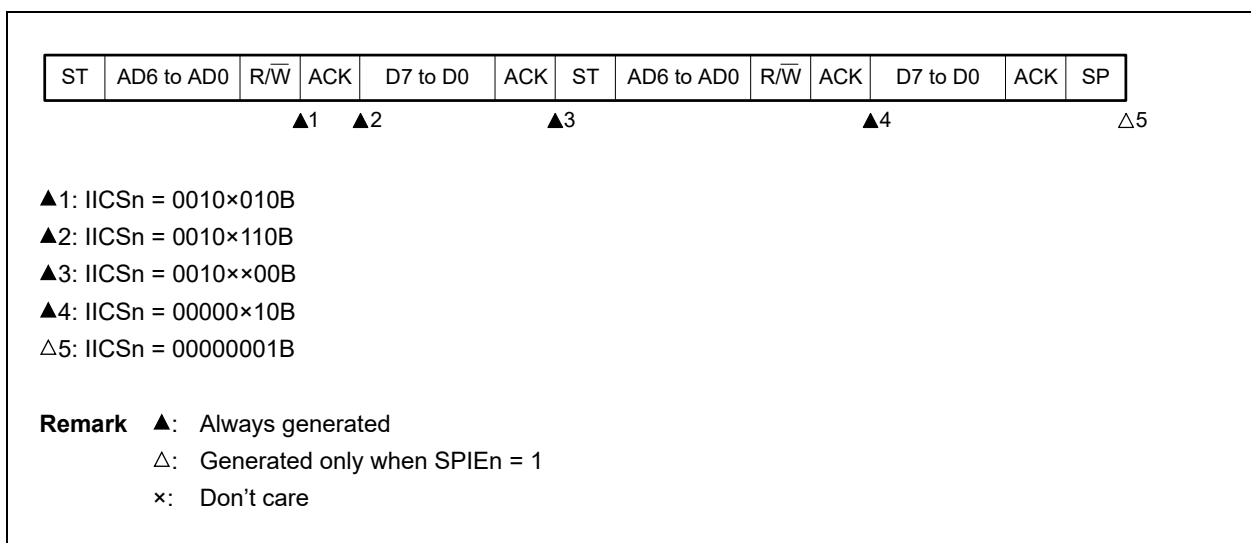

Remark n = 0, 1

(4) Operation without communication

(a) Start ~ Code ~ Data ~ Data ~ Stop

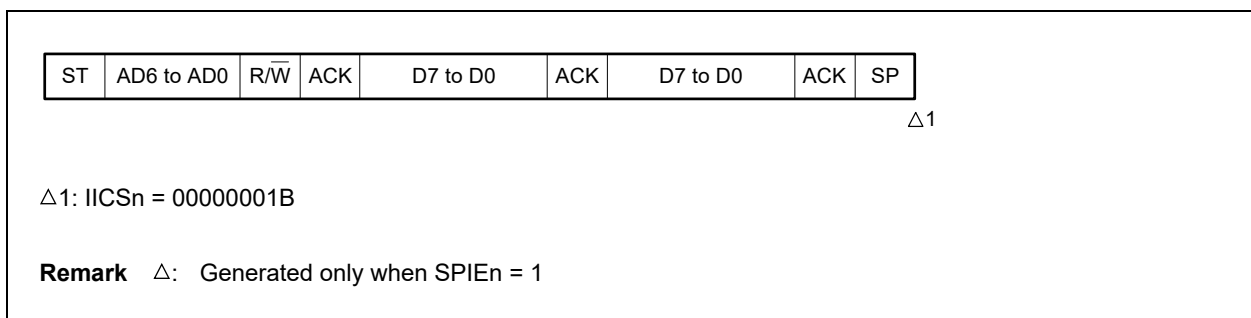

(5) Arbitration loss operation (operation as slave after arbitration loss)

When the device is used as a master in a multi-master system, read the MSTSn bit each time interrupt request signal INTIICAn has occurred to check the arbitration result.

(a) When arbitration loss occurs during transmission of slave address data

(i) When WTIMn = 0

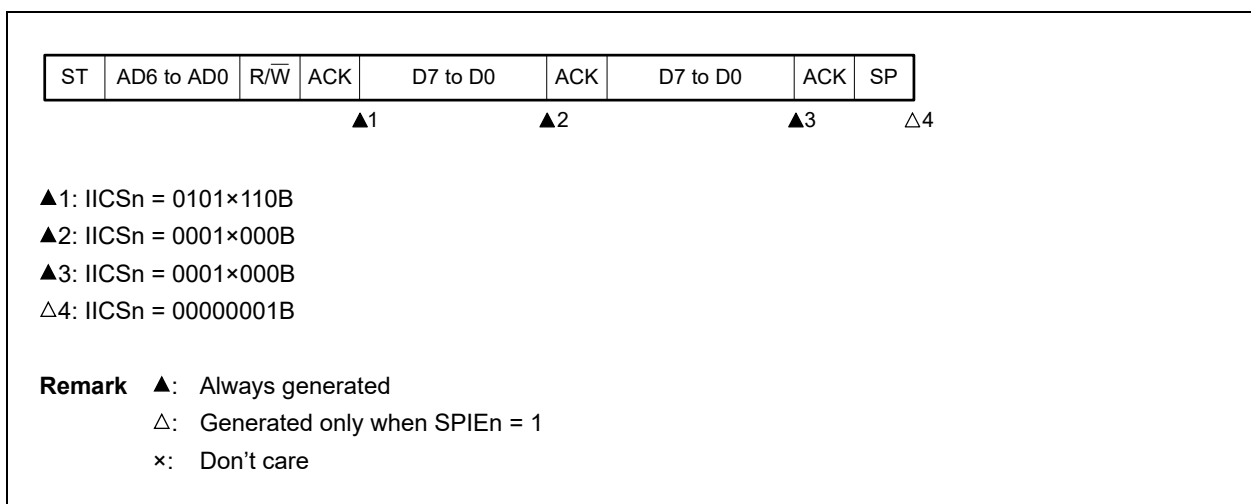

Remark n = 0, 1

(ii) When WTIMn = 1

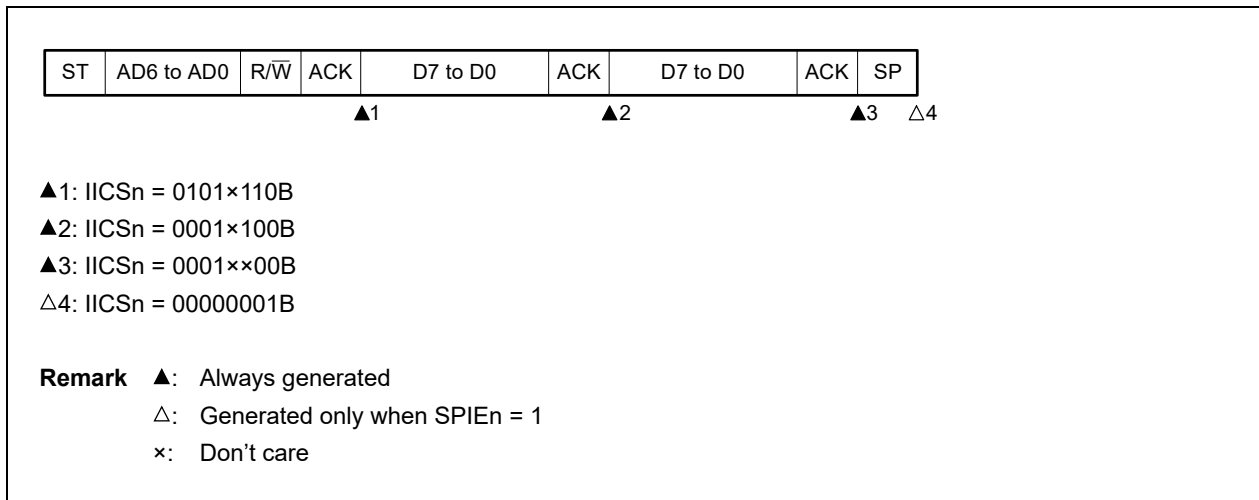

(b) When arbitration loss occurs during transmission of extension code

(i) When WTIMn = 0

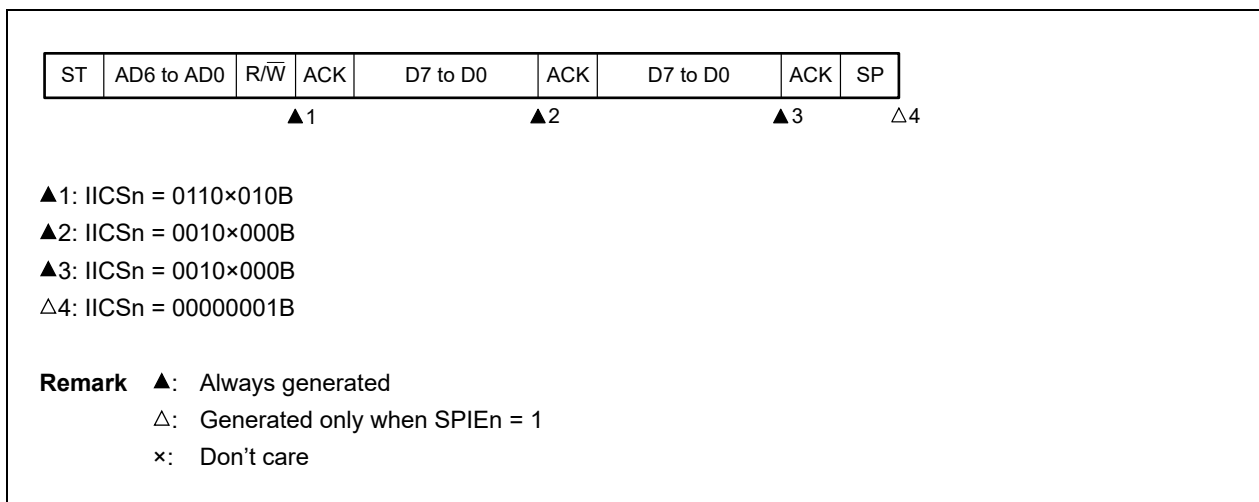

Remark n = 0, 1

(ii) When WTIMn = 1

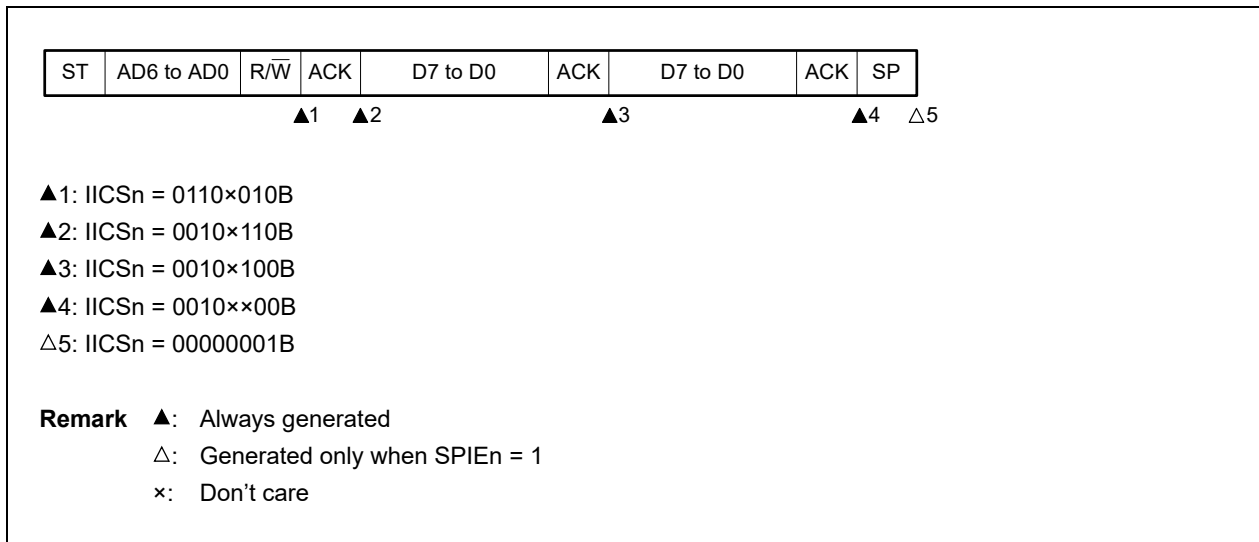

(6) Operation when arbitration loss occurs (no communication after arbitration loss)

When the device is used as a master in a multi-master system, read the MSTSn bit each time interrupt request signal INTIICAn has occurred to check the arbitration result.

(a) When arbitration loss occurs during transmission of slave address data (when WTIMn = 1)

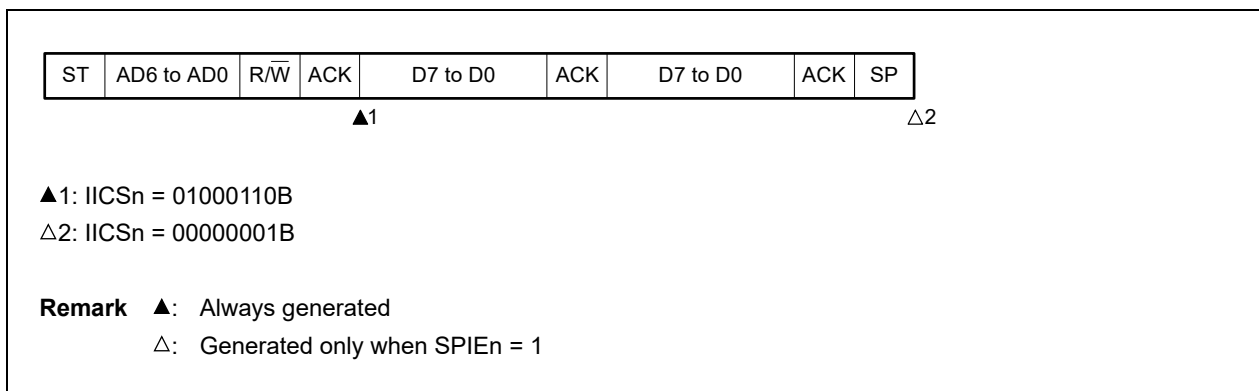

Remark n = 0, 1

(b) When arbitration loss occurs during transmission of extension code

ST	AD6 to AD0	R/W	ACK	D7 to D0	ACK	D7 to D0	ACK	SP
			▲1					△2

▲1: IICSn = 0110×010B
 Sets LRELn = 1 by software
 △2: IICSn = 00000001B

Remark ▲: Always generated
 △: Generated only when SPIEn = 1
 ×: Don't care

(c) When arbitration loss occurs during transmission of data

(i) When WTIMn = 0

ST	AD6 to AD0	R/W	ACK	D7 to D0	ACK	D7 to D0	ACK	SP
			▲1		▲2			△3

▲1: IICSn = 10001110B
 ▲2: IICSn = 01000000B
 △3: IICSn = 00000001B

Remark ▲: Always generated
 △: Generated only when SPIEn = 1

Remark n = 0, 1

(ii) When WTIMn = 1

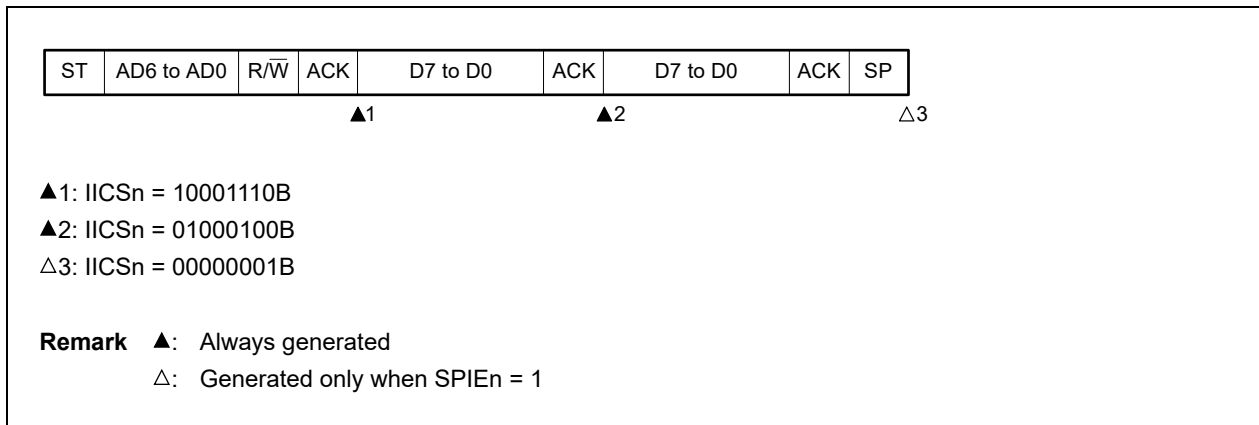

(d) When loss occurs due to restart condition during data transfer

(i) Not extension code (Example: unmatched with SVAn)

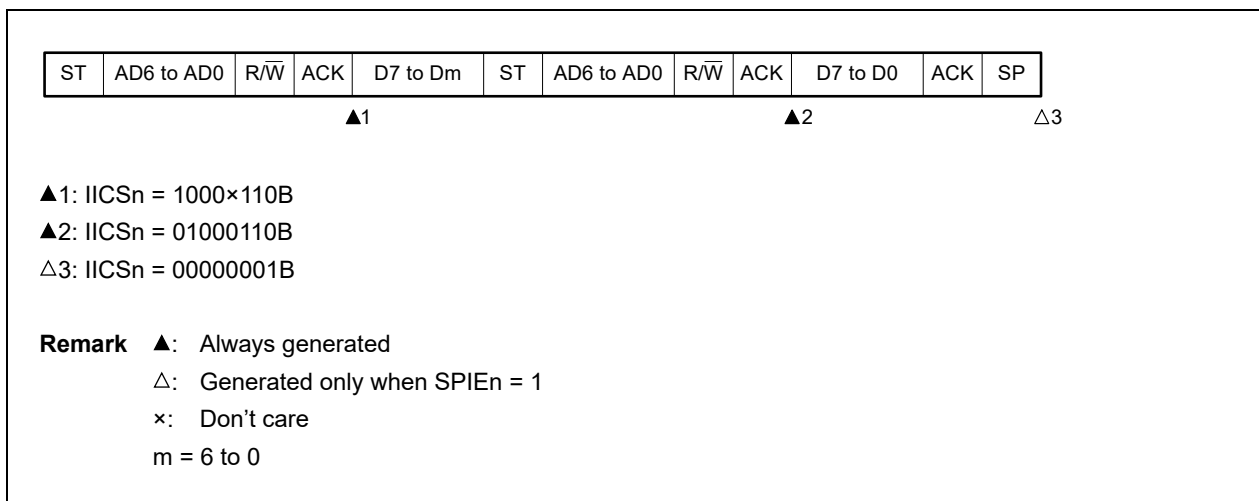

Remark n = 0, 1

(ii) Extension code

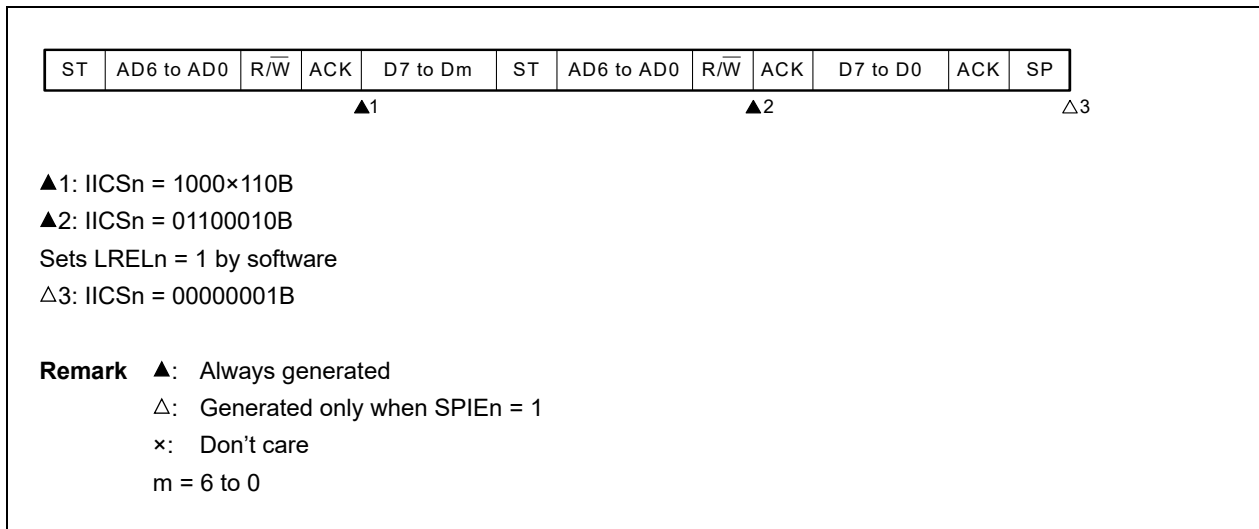

(e) When loss occurs due to stop condition during data transfer

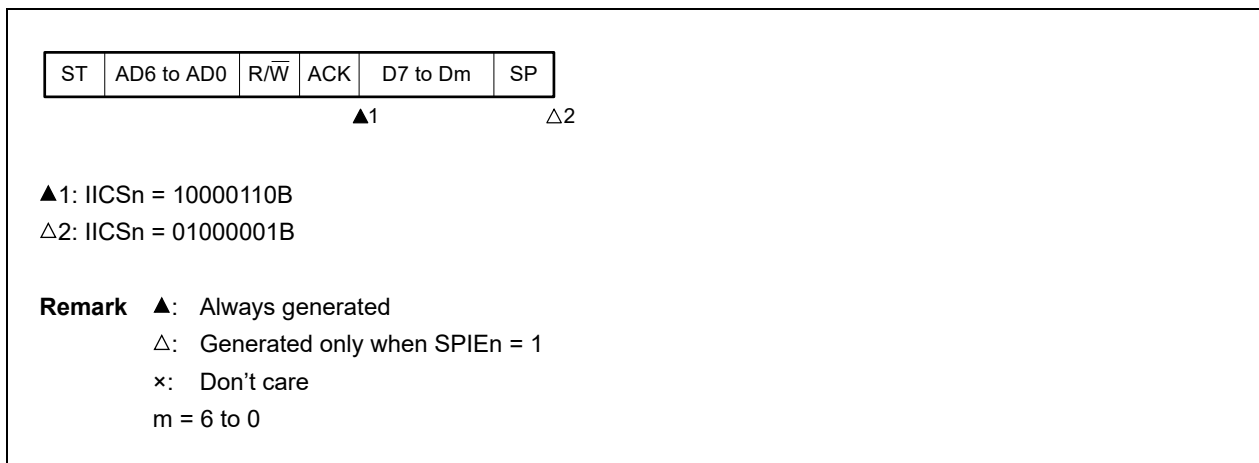

Remark n = 0, 1

(f) When arbitration loss occurs due to low-level data when attempting to generate a restart condition

(i) When WTIMn = 0

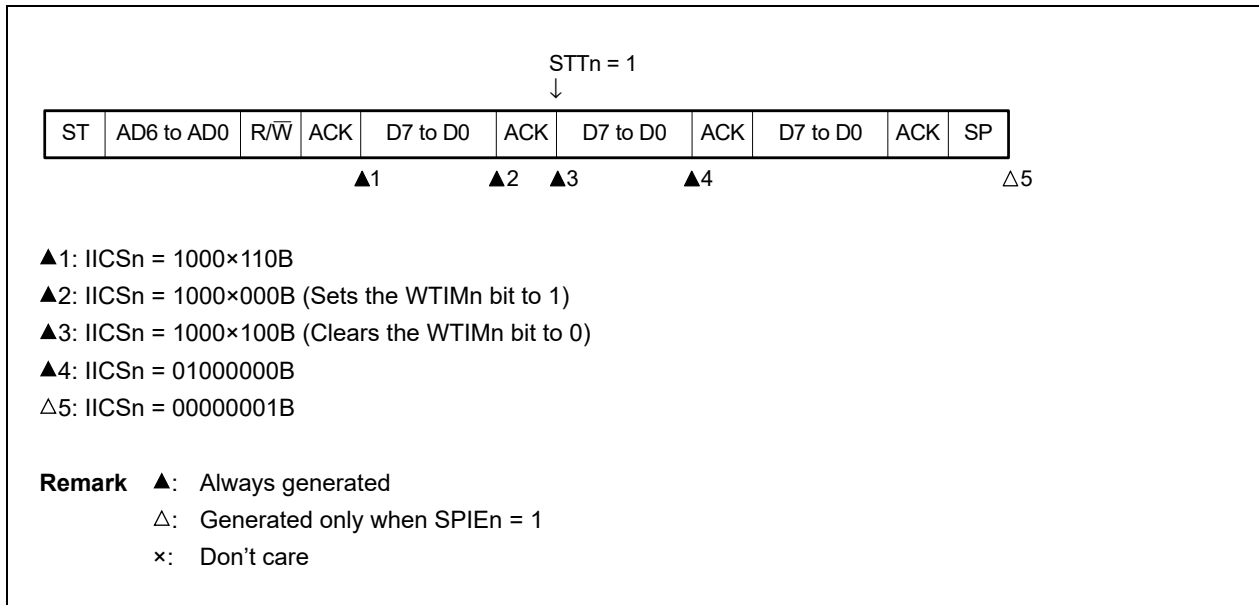

(ii) When WTIMn = 1

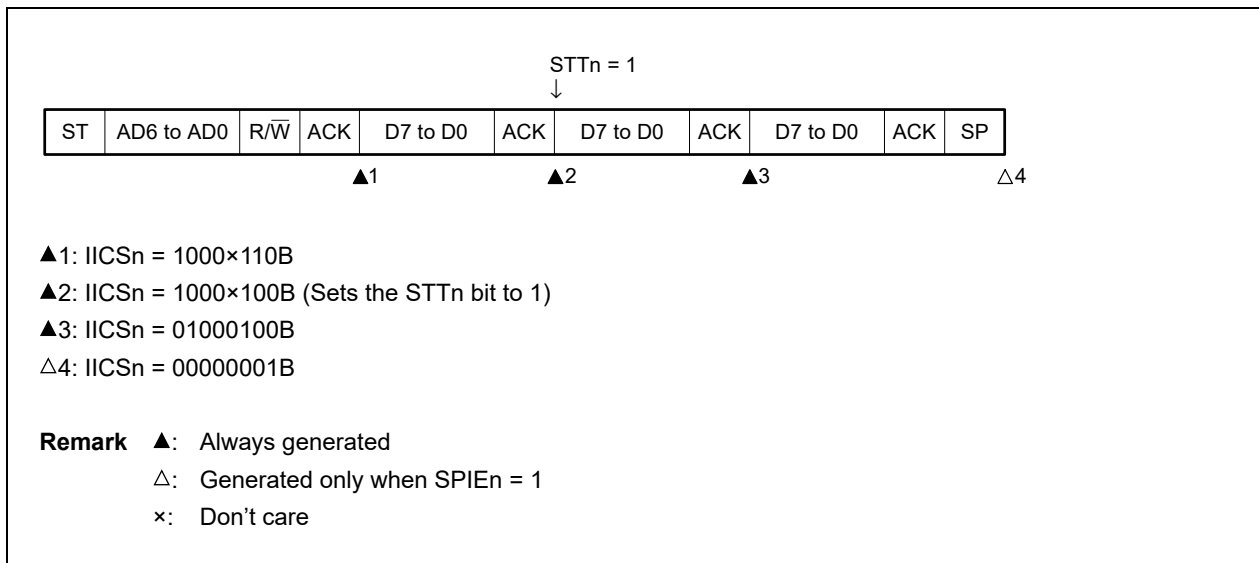

Remark n = 0, 1

(g) When arbitration loss occurs due to a stop condition when attempting to generate a restart condition

(i) When $WTIMn = 0$

ST	AD6 to AD0	R/W	ACK	D7 to D0	ACK	SP
			▲1		▲2	▲3 Δ4

STTn = 1
↓

▲1: IICSn = 1000×110B
 ▲2: IICSn = 1000×000B (Sets the WTIMn bit to 1)
 ▲3: IICSn = 1000××00B (Sets the STTn bit to 1)
 Δ4: IICSn = 01000001B

Remark ▲: Always generated
 Δ: Generated only when SPIEn = 1
 ×: Don't care

(ii) When $WTIMn = 1$

ST	AD6 to AD0	R/W	ACK	D7 to D0	ACK	SP
			▲1		▲2	Δ3

STTn = 1
↓

▲1: IICSn = 1000×110B
 ▲2: IICSn = 1000××00B (Sets the STTn bit to 1)
 Δ3: IICSn = 01000001B

Remark ▲: Always generated
 Δ: Generated only when SPIEn = 1
 ×: Don't care

Remark n = 0, 1

(h) When arbitration loss occurs due to low-level data when attempting to generate a stop condition

(i) When $WTIMn = 0$

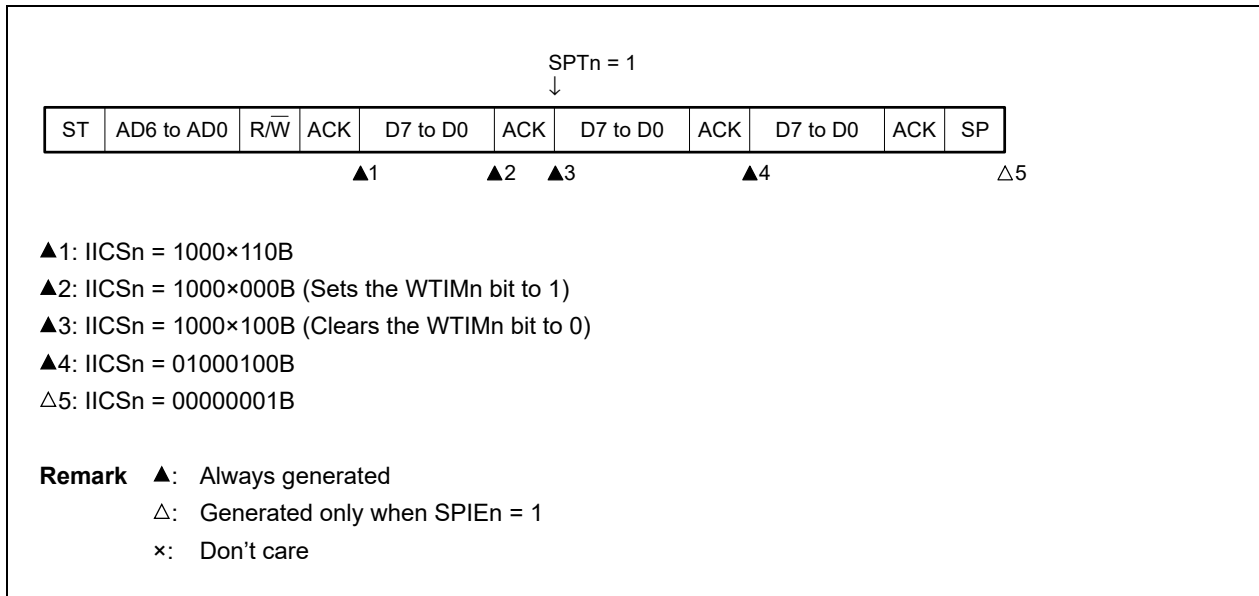

(ii) When $WTIMn = 1$

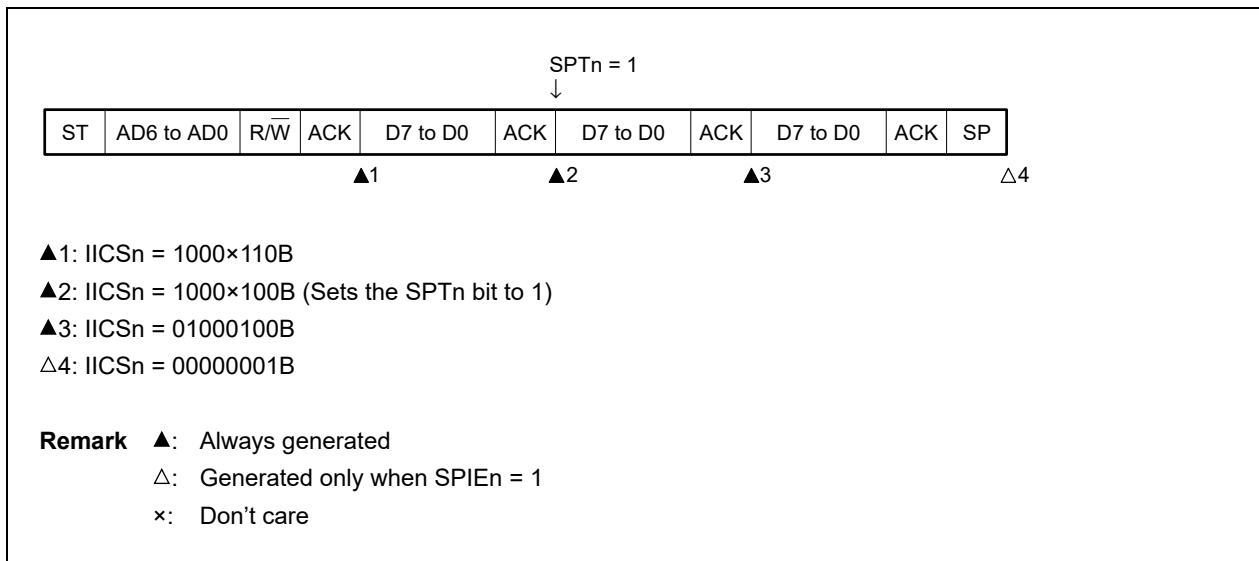

Remark n = 0, 1

13.6 Timing Charts

When using the I²C bus mode, the master device outputs an address via the serial bus to select one of several slave devices as its communication partner.

After outputting the slave address, the master device transmits the TRCn bit (bit 3 of the IICA status register n (IICSn)), which specifies the data transfer direction, and then starts serial communication with the slave device.

Figures 13-32 and 13-33 show timing charts of the data communication.

The IICA shift register n (IICAn)'s shift operation is synchronized with the falling edge of the serial clock (SCLAn). The transmit data is transferred to the SO latch and is output (MSB first) via the SDAAn pin.

Data input via the SDAAn pin is captured into IICAn at the rising edge of SCLAn.

Remark n = 0, 1

**Figure 13-32. Example of Master to Slave Communication
(9-Clock Clock Stretch Is Selected for Master, 9-Clock Clock Stretch Is Selected for Slave) (1/4)**

(1) Start condition ~ address ~ data

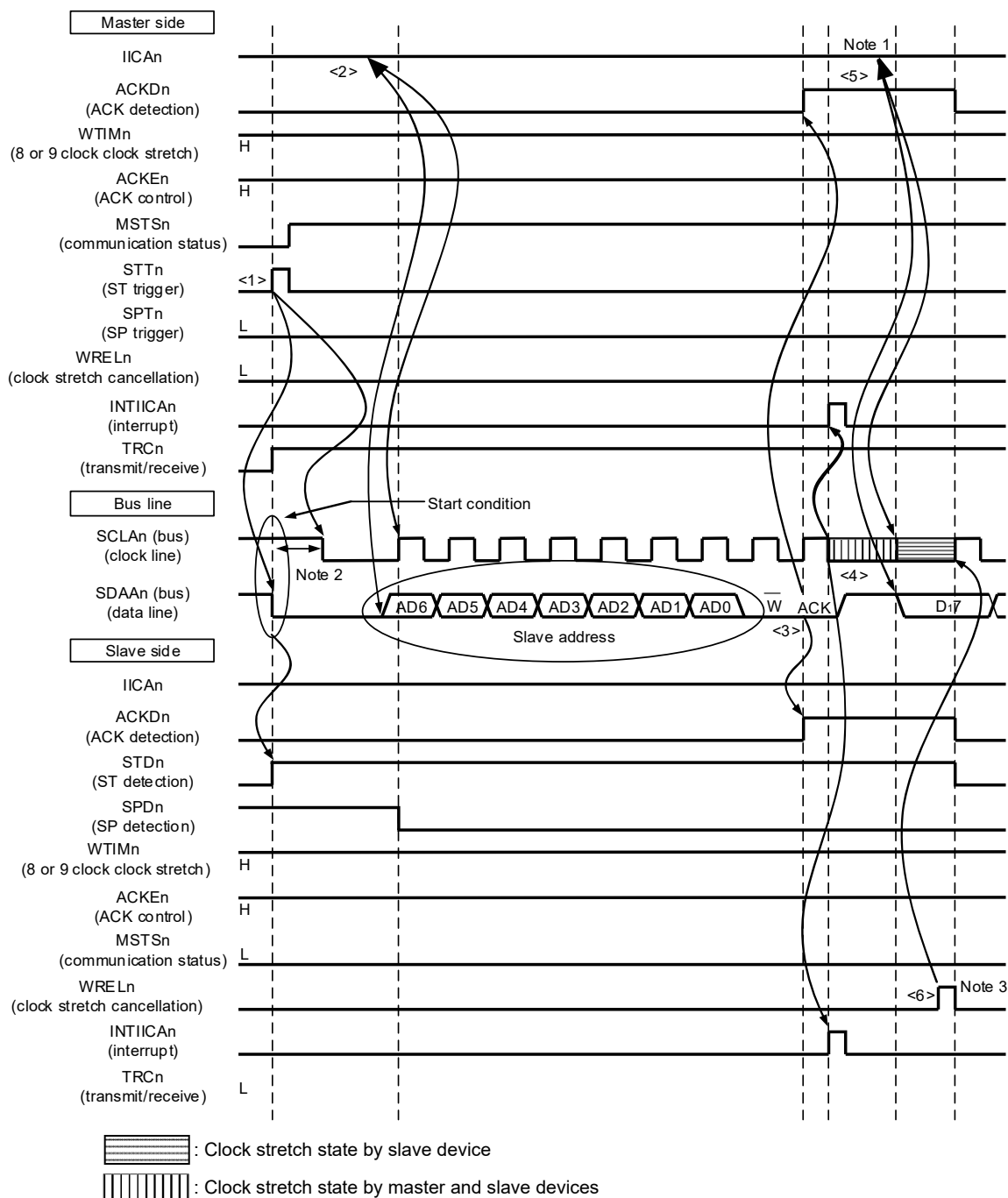

- Notes**
1. Write data to IICAn, not setting the WRELn bit, in order to cancel a clock stretch state during transmission by a master device.
 2. Make sure that the time between the fall of the SDAAn pin signal and the fall of the SCLAn pin signal is at least 4.0 μ s when specifying standard mode and at least 0.6 μ s when specifying fast mode.
 3. For releasing clock stretch state during reception of a slave device, write "FFH" to IICAn or set the WRELn bit.

Remark n = 0, 1

The meanings of <1> to <6> in (1) Start condition ~ address ~ data in Figure 13-32 are explained below.

- <1> The start condition trigger is set by the master device (STTn = 1) and a start condition (i.e. SCLAn = 1 changes SDAAn from 1 to 0) is generated once the bus data line goes low (SDAAn). When the start condition is subsequently detected, the master device enters the master device communication status (MSTS_n = 1). The master device is ready to communicate once the bus clock line goes low (SCLAn = 0) after the hold time has elapsed.
- <2> The master device writes the address + W (transmission) to the IICA shift register n (IICAn) and transmits the slave address.
- <3> In the slave device if the address received matches the address (SVAn value) of a slave device^{Note}, that slave device sends an ACK by hardware to the master device. The ACK is detected by the master device (ACKDn = 1) at the rising edge of the 9th clock.
- <4> The master device issues an interrupt (INTIICAn: end of address transmission) at the falling edge of the 9th clock. The slave device whose address matched the transmitted slave address sets a clock stretch status (SCLAn = 0) and issues an interrupt (INTIICAn: address match)^{Note}.
- <5> The master device writes the data to transmit to the IICAn register and releases the clock stretch status that it set by the master device.
- <6> If the slave device releases the clock stretch status (WRELn = 1), the master device starts transferring data to the slave device.

Note If the transmitted address does not match the address of the slave device, the slave device does not return an ACK to the master device (NACK: SDAAn = 1). The slave device also does not issue the INTIICAn interrupt (address match) and does not set a clock stretch status. The master device, however, issues the INTIICAn interrupt (end of address transmission) regardless of whether it receives an ACK or NACK.

Remarks 1. <1> to <15> in Figure 13-32 represent the entire procedure for communicating data using the I²C bus.

Figure 13-32 (1) Start condition ~ address ~ data shows the processing from <1> to <6>, Figure 13-32 (2) Address ~ data ~ data shows the processing from <3> to <10>, and Figure 13-32 (3) Data ~ data ~ stop condition shows the processing from <7> to <15>.

- 2. n = 0, 1

Figure 13-32. Example of Master to Slave Communication
(9-Clock Clock Stretch Is Selected for Master, 9-Clock Clock Stretch Is Selected for Slave) (2/4)

(2) Address ~ data ~ data

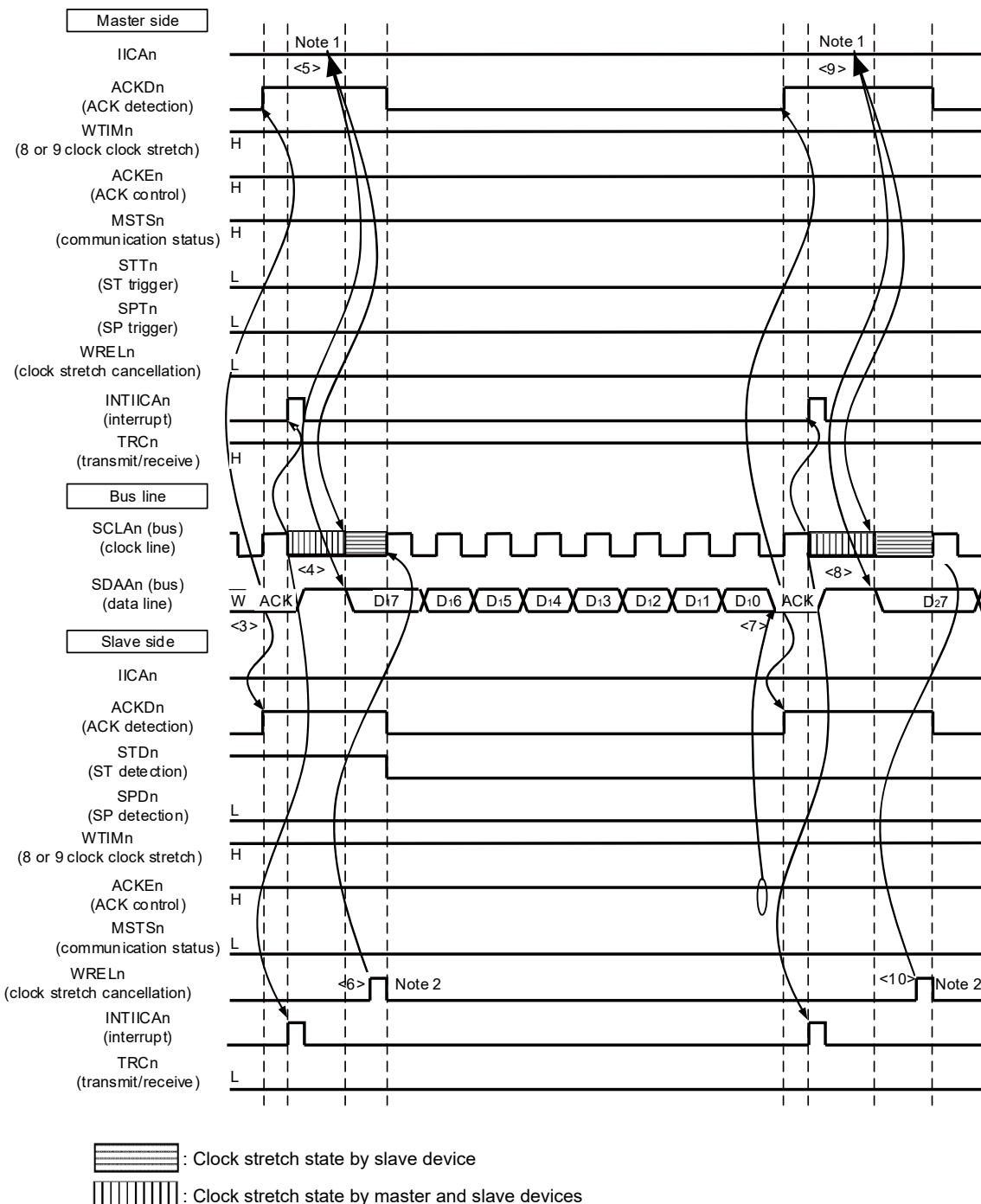

Notes 1. Write data to IICAn, not setting the WRELn bit, in order to cancel a clock stretch state during transmission by a master device.

2. For releasing clock stretch state during reception of a slave device, write "FFH" to IICAn or set the WRELn bit.

Remark n = 0, 1

The meanings of <3> to <10> in (2) Address ~ data ~ data in Figure 13-32 are explained below.

- <3> In the slave device if the address received matches the address (SVAn value) of a slave device^{Note}, that slave device sends an ACK by hardware to the master device. The ACK is detected by the master device (ACKDn = 1) at the rising edge of the 9th clock.
- <4> The master device issues an interrupt (INTIICAn: end of address transmission) at the falling edge of the 9th clock. The slave device whose address matched the transmitted slave address sets a clock stretch status (SCLAn = 0) and issues an interrupt (INTIICAn: address match)^{Note}.
- <5> The master device writes the data to transmit to the IICA shift register n (IICAn) and releases the clock stretch status that it set by the master device.
- <6> If the slave device releases the clock stretch status (WRELn = 1), the master device starts transferring data to the slave device.
- <7> After data transfer is completed, because of ACKEn = 1, the slave device sends an ACK by hardware to the master device. The ACK is detected by the master device (ACKDn = 1) at the rising edge of the 9th clock.
- <8> The master device and slave device set a clock stretch status (SCLAn = 0) at the falling edge of the 9th clock, and both the master device and slave device issue an interrupt (INTIICAn: end of transfer).
- <9> The master device writes the data to transmit to the IICAn register and releases the clock stretch status that it set by the master device.
- <10> The slave device reads the received data and releases the clock stretch status (WRELn = 1). The master device then starts transferring data to the slave device.

Note If the transmitted address does not match the address of the slave device, the slave device does not return an ACK to the master device (NACK: SDAA_n = 1). The slave device also does not issue the INTIICAn interrupt (address match) and does not set a clock stretch status. The master device, however, issues the INTIICAn interrupt (end of address transmission) regardless of whether it receives an ACK or NACK.

Remarks 1. <1> to <15> in Figure 13-32 represent the entire procedure for communicating data using the I²C bus.

Figure 13-32 (1) Start condition ~ address ~ data shows the processing from <1> to <6>, Figure 13-32 (2) Address ~ data ~ data shows the processing from <3> to <10>, and Figure 13-32 (3) Data ~ data ~ stop condition shows the processing from <7> to <15>.

2. n = 0, 1

Figure 13-32. Example of Master to Slave Communication
(9-Clock ClockStretch Is Selected for Master, 9-Clock Clock Stretch Is Selected for Slave) (3/4)

(3) Data ~ data ~ Stop condition

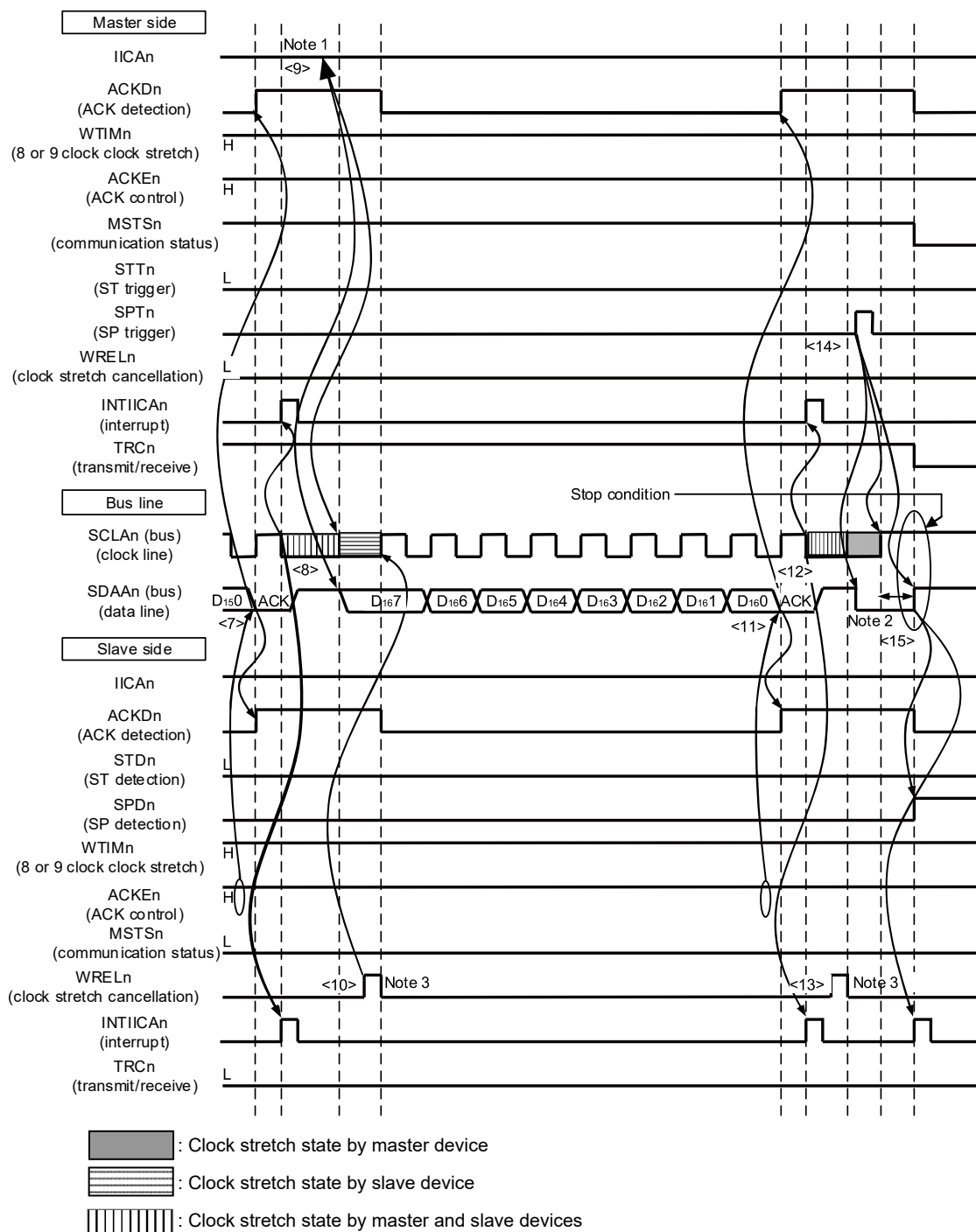

- Notes**
1. Write data to IICAn, not setting the WRELn bit, in order to cancel a clock stretch state during transmission by a master device.
 2. Make sure that the time between the rise of the SCLAn pin signal and the generation of the stop condition after a stop condition has been issued is at least 4.0 μs when specifying standard mode and at least 0.6 μs when specifying fast mode.
 3. For releasing clock stretch state during reception of a slave device, write “FFH” to IICAn or set the WRELn bit.

Remark n = 0, 1

The meanings of <7> to <15> in (3) Data ~ data ~ stop condition in Figure 13-32 are explained below.

- <7> After data transfer is completed, because of ACKEn = 1, the slave device sends an ACK by hardware to the master device. The ACK is detected by the master device (ACKDn = 1) at the rising edge of the 9th clock.
- <8> The master device and slave device set a clock stretch status (SCLAn = 0) at the falling edge of the 9th clock, and both the master device and slave device issue an interrupt (INTIICAn: end of transfer).
- <9> The master device writes the data to transmit to the IICA shift register n (IICAn) and releases the clock stretch status that it set by the master device.
- <10> The slave device reads the received data and releases the clock stretch status (WRELn = 1). The master device then starts transferring data to the slave device.
- <11> When data transfer is complete, the slave device (ACKEn = 1) sends an ACK by hardware to the master device. The ACK is detected by the master device (ACKDn = 1) at the rising edge of the 9th clock.
- <12> The master device and slave device set a clock stretch status (SCLAn = 0) at the falling edge of the 9th clock, and both the master device and slave device issue an interrupt (INTIICAn: end of transfer).
- <13> The slave device reads the received data and releases the clock stretch status (WRELn = 1).
- <14> By the master device setting a stop condition trigger (SPTn = 1), the bus data line is cleared (SDAAn = 0) and the bus clock line is set (SCLAn = 1). After the stop condition setup time has elapsed, by setting the bus data line (SDAAn = 1), the stop condition is then generated (i.e. SCLAn = 1 changes SDAAn from 0 to 1).
- <15> When a stop condition is generated, the slave device detects the stop condition and issues an interrupt (INTIICAn: stop condition).

Remarks 1. <1> to <15> in Figure 13-32 represent the entire procedure for communicating data using the I²C bus.

Figure 13-32 (1) Start condition ~ address ~ data shows the processing from <1> to <6>, Figure 13-32 (2) Address ~ data ~ data shows the processing from <3> to <10>, and Figure 13-32 (3) Data ~ data ~ stop condition shows the processing from <7> to <15>.

- 2. n = 0, 1

Figure 13-32. Example of Master to Slave Communication
(9-Clock Clock Stretch Is Selected for Master, 9-Clock Clock Stretch Is Selected for Slave) (4/4)

(4) Data ~ restart condition ~ address

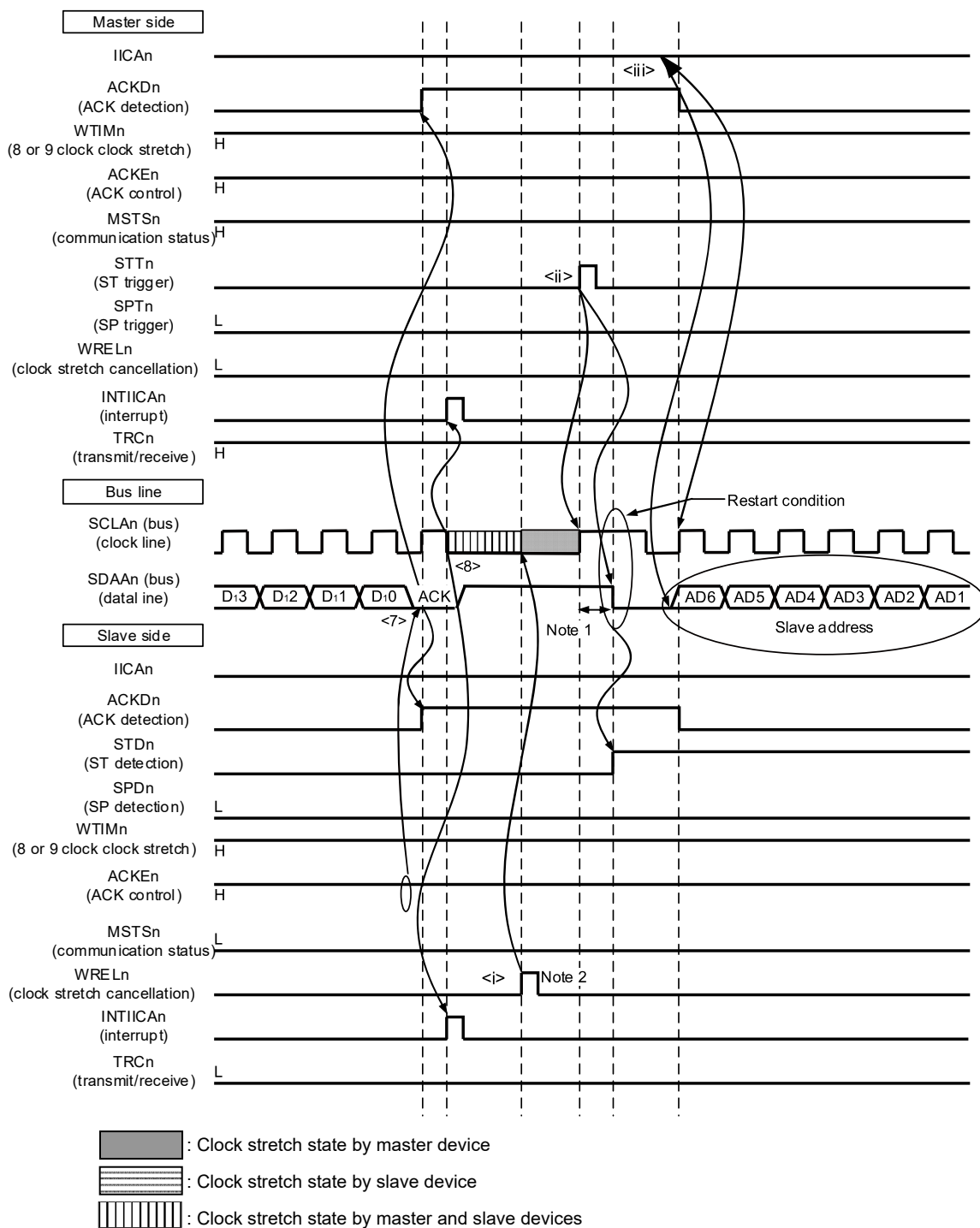

- Notes**
1. Make sure that the time between the rise of the SCLAn pin signal and the generation of the start condition after a restart condition has been issued is at least 4.7 μs when specifying standard mode and at least 0.6 μs when specifying fast mode.
 2. For releasing clock stretch state during reception of a slave device, write "FFH" to IICAn or set the WRELn bit.

Remark n = 0, 1

The following describes the operations in Figure 13-32 (4) Data ~ restart condition ~ address. After the operations in steps <7> and <8>, the operations in steps <i> to <iii> are performed. These steps return the processing to step <iii>, the data transmission step.

- <7> After data transfer is completed, because of ACKEn = 1, the slave device sends an ACK by hardware to the master device. The ACK is detected by the master device (ACKDn = 1) at the rising edge of the 9th clock.
- <8> The master device and slave device set a clock stretch status (SCLAn = 0) at the falling edge of the 9th clock, and both the master device and slave device issue an interrupt (INTIICAn: end of transfer).
- <i> The slave device reads the received data and releases the clock stretch status (WRELn = 1).
- <ii> The start condition trigger is set again by the master device (STTn = 1) and a start condition (i.e. SCLAn = 1 changes SDAAn from 1 to 0) is generated once the bus clock line goes high (SCLAn = 1) and the bus data line goes low (SDAAn = 0) after the restart condition setup time has elapsed. When the start condition is subsequently detected, the master device is ready to communicate once the bus clock line goes low (SCLAn = 0) after the hold time has elapsed.
- <iii> The master device writing the address + R/W (transmission) to the IICA shift register (IICAn) enables the slave address to be transmitted.

Remark n = 0, 1

Figure 13-33. Example of Slave to Master Communication
(8-Clock Clock Stretch Is Selected for Master, 9-Clock Clock Stretch Is Selected for Slave) (1/3)

(1) Start condition ~ address ~ data

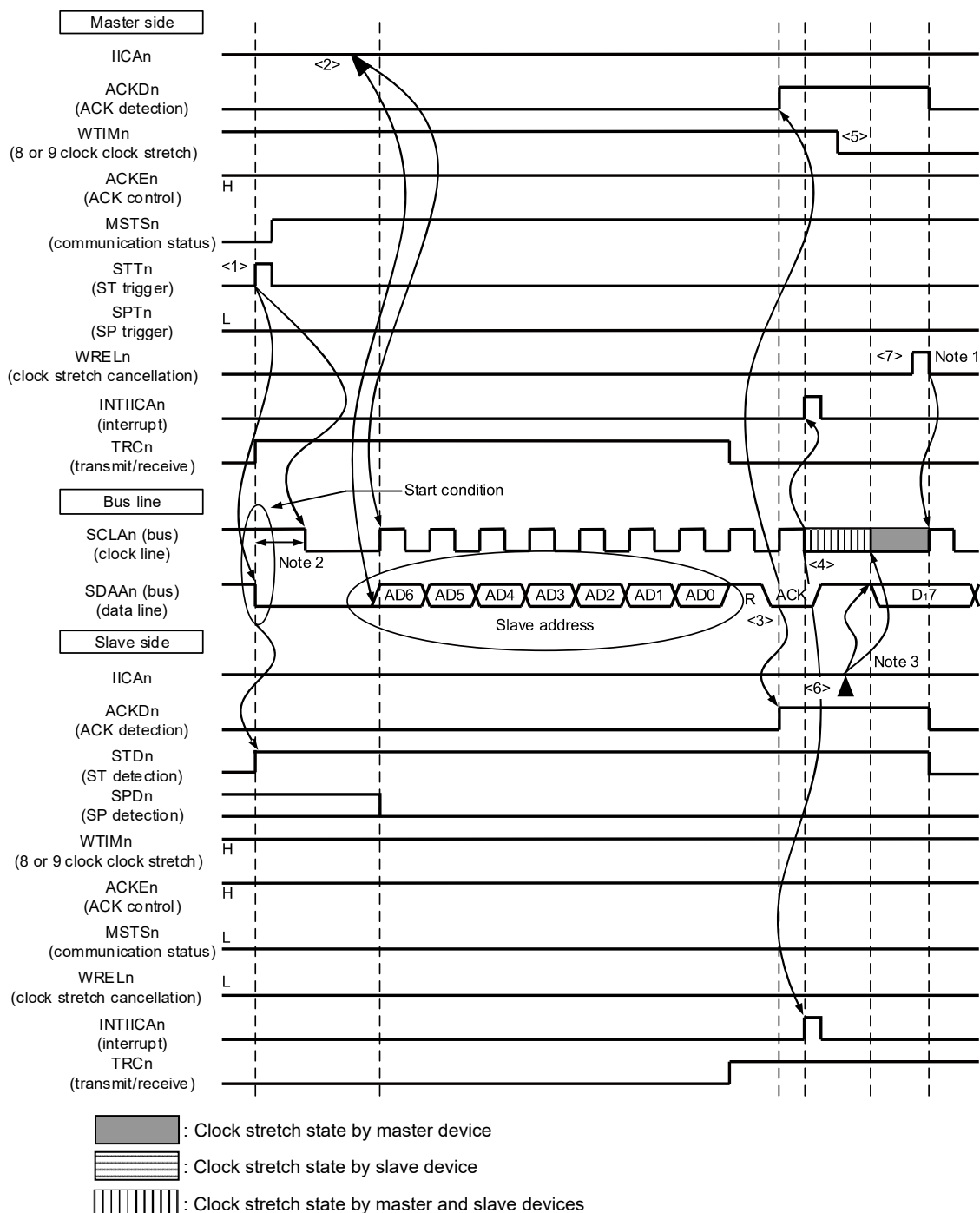

- Notes**
- For releasing clock stretch state during reception of a master device, write "FFH" to IICAn or set the WRELn bit.
 - Make sure that the time between the fall of the SDAAn pin signal and the fall of the SCLAn pin signal is at least 4.0 μs when specifying standard mode and at least 0.6 μs when specifying fast mode.
 - Write data to IICAn, not setting the WRELn bit, in order to cancel a clock stretch state during transmission by a slave device.

Remark n = 0, 1

The meanings of <1> to <7> in (1) Start condition ~ address ~ data in Figure 13-33 are explained below.

- <1> The start condition trigger is set by the master device (STTn = 1) and a start condition (i.e. SCLAn = 1 changes SDAAn from 1 to 0) is generated once the bus data line goes low (SDAAn). When the start condition is subsequently detected, the master device enters the master device communication status (MSTSn = 1). The master device is ready to communicate once the bus clock line goes low (SCLAn = 0) after the hold time has elapsed.
- <2> The master device writes the address + R (reception) to the IICA shift register n (IICAn) and transmits the slave address.
- <3> In the slave device if the address received matches the address (SVAn value) of a slave device ^{Note}, that slave device sends an ACK by hardware to the master device. The ACK is detected by the master device (ACKDn = 1) at the rising edge of the 9th clock.
- <4> The master device issues an interrupt (INTIICAn: end of address transmission) at the falling edge of the 9th clock. The slave device whose address matched the transmitted slave address sets a clock stretch status (SCLAn = 0) and issues an interrupt (INTIICAn: address match) ^{Note}.
- <5> The timing at which the master device sets the clock stretch status changes to the 8th clock (WTIMn = 0).
- <6> The slave device writes the data to transmit to the IICAn register and releases the clock stretch status that it set by the slave device.
- <7> The master device releases the clock stretch status (WRELn = 1) and starts transferring data from the slave device to the master device.

Note If the transmitted address does not match the address of the slave device, the slave device does not return an ACK to the master device (NACK: SDAAn = 1). The slave device also does not issue the INTIICAn interrupt (address match) and does not set a clock stretch status. The master device, however, issues the INTIICAn interrupt (end of address transmission) regardless of whether it receives an ACK or NACK.

Remarks 1. <1> to <19> in Figure 13-33 represent the entire procedure for communicating data using the I²C bus.

Figure 13-33 (1) Start condition ~ address ~ data shows the processing from <1> to <7>, Figure 13-33 (2) Address ~ data ~ data shows the processing from <3> to <12>, and Figure 13-33 (3) Data ~ data ~ stop condition shows the processing from <8> to <19>.

- 2. n = 0, 1

Figure 13-33. Example of Slave to Master Communication
(8-Clock Clock Stretch Is Selected for Master, 9-Clock Clock Stretch Is Selected for Slave) (2/3)

(2) Address ~ data ~ data

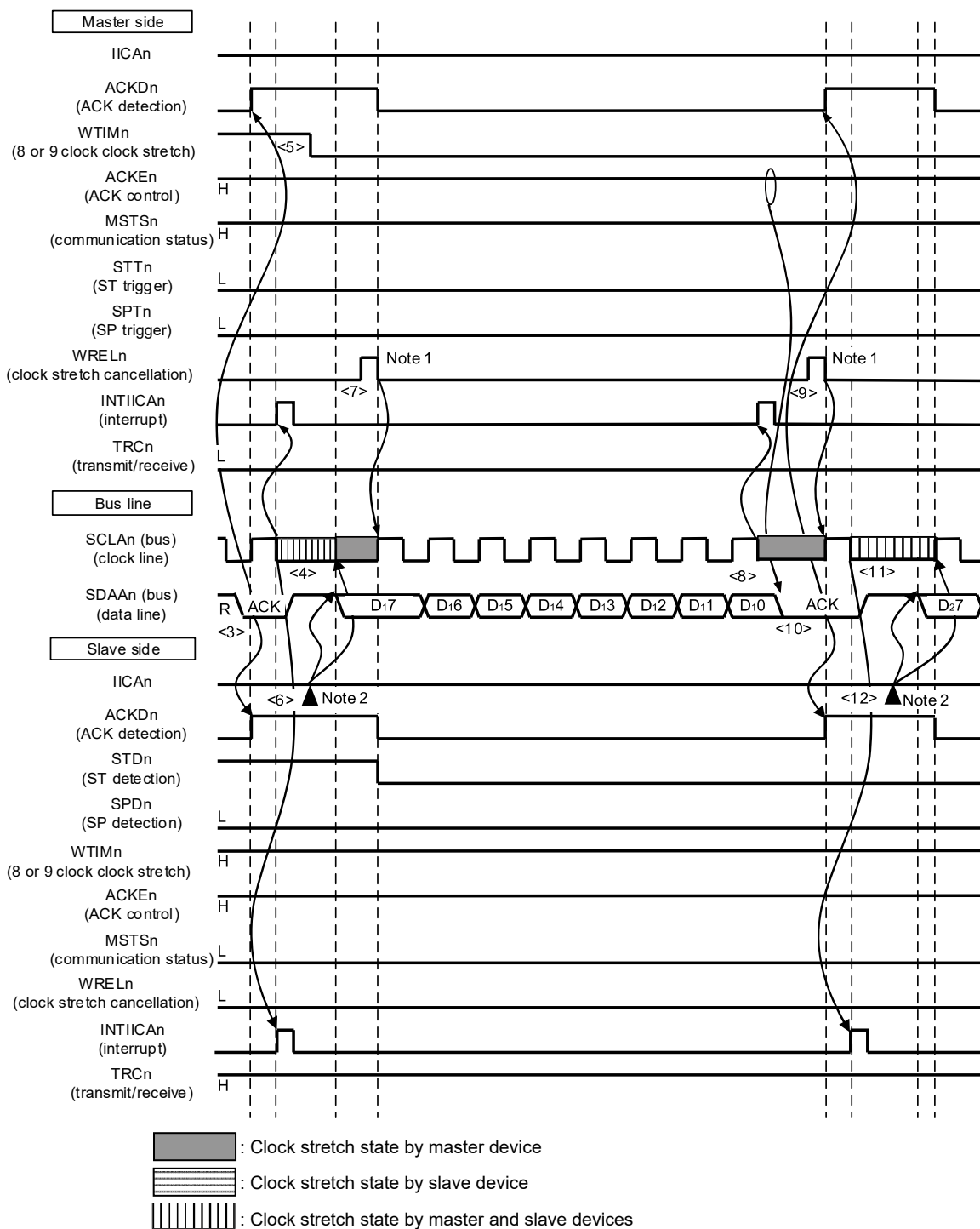

- Notes**
- For releasing clock stretch state during reception of a master device, write “FFH” to IICAn or set the WRELn bit.
 - Write data to IICAn, not setting the WRELn bit, in order to cancel a clock stretch state during transmission by a slave device.

Remark n = 0, 1

The meanings of <3> to <12> in (2) Address ~ data ~ data in Figure 13-33 are explained below.

- <3> In the slave device if the address received matches the address (SVAn value) of a slave device^{Note}, that slave device sends an ACK by hardware to the master device. The ACK is detected by the master device (ACKDn = 1) at the rising edge of the 9th clock.
- <4> The master device issues an interrupt (INTIICAn: end of address transmission) at the falling edge of the 9th clock. The slave device whose address matched the transmitted slave address sets a clock stretch status (SCLAn = 0) and issues an interrupt (INTIICAn: address match)^{Note}.
- <5> The master device changes the timing of the clock stretch status to the 8th clock (WTIMn = 0).
- <6> The slave device writes the data to transmit to the IICA shift register n (IICAn) and releases the clock stretch status that it set by the slave device.
- <7> The master device releases the clock stretch status (WRELn = 1) and starts transferring data from the slave device to the master device.
- <8> The master device sets a clock stretch status (SCLAn = 0) at the falling edge of the 8th clock, and issues an interrupt (INTIICAn: end of transfer). Because of ACKEn = 1 in the master device, the master device then sends an ACK by hardware to the slave device.
- <9> The master device reads the received data and releases the clock stretch status (WRELn = 1).
- <10> The ACK is detected by the slave device (ACKDn = 1) at the rising edge of the 9th clock.
- <11> The slave device set a clock stretch status (SCLAn = 0) at the falling edge of the 9th clock, and the slave device issue an interrupt (INTIICAn: end of transfer).
- <12> By the slave device writing the data to transmit to the IICAn register, the clock stretch status set by the slave device is released. The slave device then starts transferring data to the master device.

Note If the transmitted address does not match the address of the slave device, the slave device does not return an ACK to the master device (NACK: SDAAn = 1). The slave device also does not issue the INTIICAn interrupt (address match) and does not set a clock stretch status. The master device, however, issues the INTIICAn interrupt (end of address transmission) regardless of whether it receives an ACK or NACK.

Remarks 1. <1> to <19> in Figure 13-33 represent the entire procedure for communicating data using the I²C bus.

Figure 13-33 (1) Start condition ~ address ~ data shows the processing from <1> to <7>, Figure 13-33 (2) Address ~ data ~ data shows the processing from <3> to <12>, and Figure 13-33 (3) Data ~ data ~ stop condition shows the processing from <8> to <19>.

2. n = 0, 1

Figure 13-33. Example of Slave to Master Communication
(8-Clock and 9-Clock Clock Stretch Is Selected for Master, 9-Clock Clock Stretch Is Selected for Slave) (3/3)

(3) Data ~ data ~ stop condition

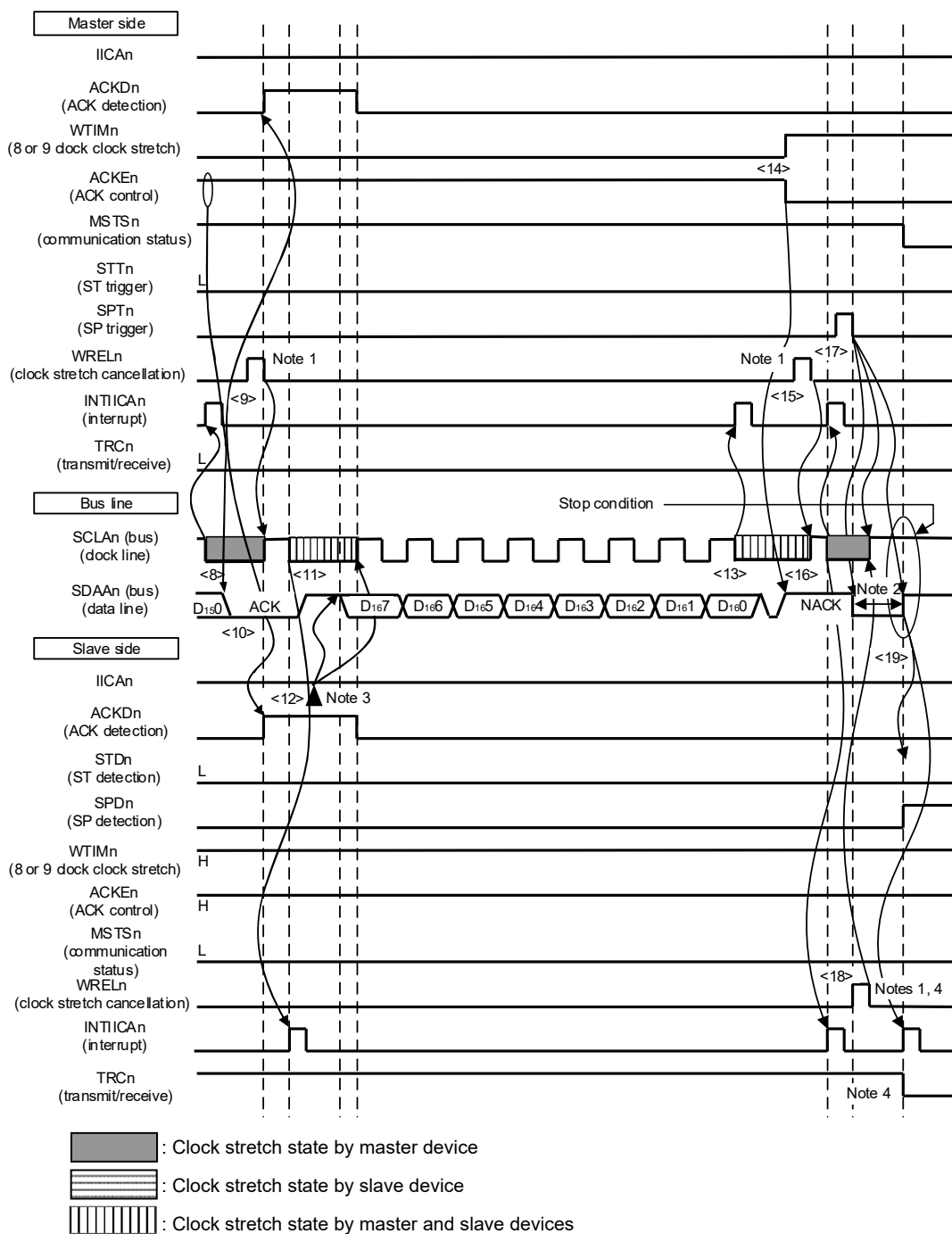

- Notes**
- To cancel a clock stretch state, write "FFH" to IICAn or set the WRELn bit.
 - Make sure that the time between the rise of the SCLAn pin signal and the generation of the stop condition after a stop condition has been issued is at least 4.0 μs when specifying standard mode and at least 0.6 μs when specifying fast mode.
 - Write data to IICAn, not setting the WRELn bit, in order to cancel a clock stretch state during transmission by a slave device.
 - If a clock stretch state during transmission by a slave device is canceled by setting the WRELn bit, the TRCn bit will be cleared.

Remark n = 0, 1

The meanings of <8> to <19> in (3) Data ~ data ~ stop condition in Figure 13-33 are explained below.

- <8> The master device sets a clock stretch status (SCLAn = 0) at the falling edge of the 8th clock, and issues an interrupt (INTIICAn: end of transfer). Because of ACKEn = 0 in the master device, the master device then sends an ACK by hardware to the slave device.
- <9> The master device reads the received data and releases the clock stretch status (WRELn = 1).
- <10> The ACK is detected by the slave device (ACKDn = 1) at the rising edge of the 9th clock.
- <11> The slave device set a clock stretch status (SCLAn = 0) at the falling edge of the 9th clock, and the slave device issue an interrupt (INTIICAn: end of transfer).
- <12> By the slave device writing the data to transmit to the IICA register, the clock stretch status set by the slave device is released. The slave device then starts transferring data to the master device.
- <13> The master device issues an interrupt (INTIICAn: end of transfer) at the falling edge of the 8th clock, and sets a clock stretch status (SCLAn = 0). Because ACK control (ACKEn = 1) is performed, the bus data line is at the low level (SDAAn = 0) at this stage.
- <14> The master device sets NACK as the response (ACKEn = 0) and changes the timing at which it sets the clock stretch status to the 9th clock stretch (WTIMn = 1).
- <15> If the master device releases the clock stretch status (WRELn = 1), the slave device detects the NACK (ACK = 0) at the rising edge of the 9th clock stretch.
- <16> The master device and slave device set a clock stretch status (SCLAn = 0) at the falling edge of the 9th clock, and both the master device and slave device issue an interrupt (INTIICAn: end of transfer).
- <17> When the master device issues a stop condition (SPTn = 1), the bus data line is cleared (SDAAn = 0) and the master device releases the clock stretch status. The master device then clock stretches until the bus clock line is set (SCLAn = 1).
- <18> The slave device acknowledges the NACK, halts transmission, and releases the clock stretch status (WRELn = 1) to end communication. Once the slave device releases the clock stretch status, the bus clock line is set (SCLAn = 1).
- <19> Once the master device recognizes that the bus clock line is set (SCLAn = 1) and after the stop condition setup time has elapsed, the master device sets the bus data line (SDAAn = 1) and issues a stop condition (i.e. SCLAn =1 changes SDAAn from 0 to 1). The slave device detects the generated stop condition and slave device issue an interrupt (INTIICAn: stop condition).

Remarks 1. <1> to <19> in Figure 13-33 represent the entire procedure for communicating data using the I²C bus.

Figure 13-33 (1) Start condition ~ address ~ data shows the processing from <1> to <7>, Figure 13-33 (2) Address ~ data ~ data shows the processing from <3> to <12>, and Figure 13-33 (3) Data ~ data ~ stop condition shows the processing from <8> to <19>.

2. n = 0, 1

CHAPTER 14 MULTIPLIER AND DIVIDER/MULTIPLY-ACCUMULATOR

14.1 Functions of Multiplier and Divider/Multiply-Accumulator

The multiplier and divider/multiply-accumulator has the following functions.

- $16 \text{ bits} \times 16 \text{ bits} = 32 \text{ bits}$ (Unsigned)
- $16 \text{ bits} \times 16 \text{ bits} = 32 \text{ bits}$ (Signed)
- $16 \text{ bits} \times 16 \text{ bits} + 32 \text{ bits} = 32 \text{ bits}$ (Unsigned)
- $16 \text{ bits} \times 16 \text{ bits} + 32 \text{ bits} = 32 \text{ bits}$ (Signed)
- $32 \text{ bits} \div 32 \text{ bits} = 32 \text{ bits}$, 32-bits remainder (Unsigned)

14.2 Configuration of Multiplier and Divider/Multiply-Accumulator

The multiplier and divider/multiply-accumulator consists of the following hardware.

Table 14-1. Configuration of Multiplier and Divider/Multiply-Accumulator

Item	Configuration
Registers	Multiplication/division data register A (L) (MDAL) Multiplication/division data register A (H) (MDAH) Multiplication/division data register B (L) (MDBL) Multiplication/division data register B (H) (MDBH) Multiplication/division data register C (L) (MDCL) Multiplication/division data register C (H) (MDCH)
Control register	Multiplication/division control register (MDUC)

Figure 14-1 shows a block diagram of the multiplier and divider/multiply-accumulator.

Figure 14-1. Block Diagram of Multiplier and Divider/Multiply-Accumulator

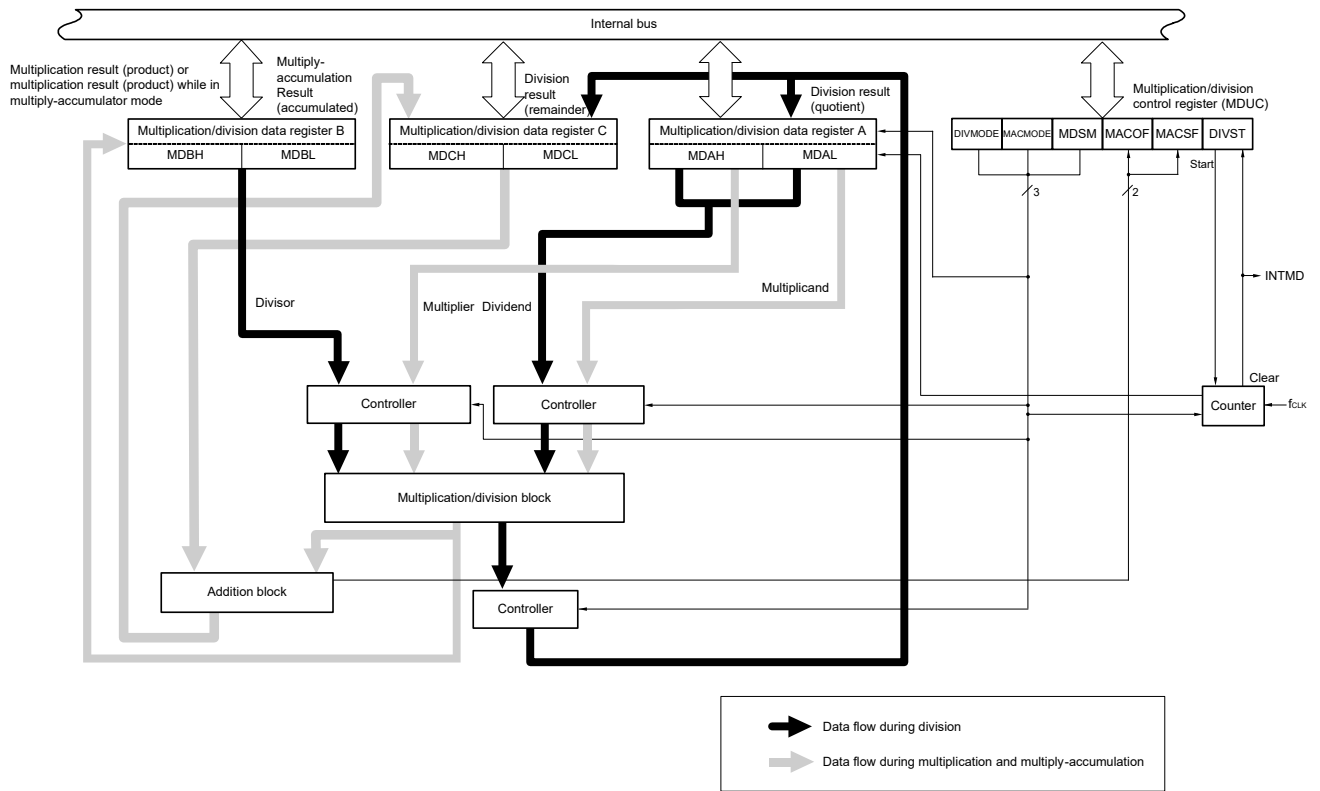

Remark f_{CLK}: CPU/peripheral hardware clock frequency

14.2.1 Multiplication/division data register A (MDAH, MDAL)

The MDAH and MDAL registers set the values that are used for a multiplication or division operation and store the operation result. They set the multiplier and multiplicand data in the multiplication mode or multiply-accumulator mode, and set the dividend data in the division mode. Furthermore, the operation result (quotient) is stored in the MDAH and MDAL registers in the division mode.

The MDAH and MDAL registers can be set by a 16-bit manipulation instruction.

Reset signal generation clears these registers to 0000H.

Figure 14-2. Format of Multiplication/Division Data Register A (MDAH, MDAL)

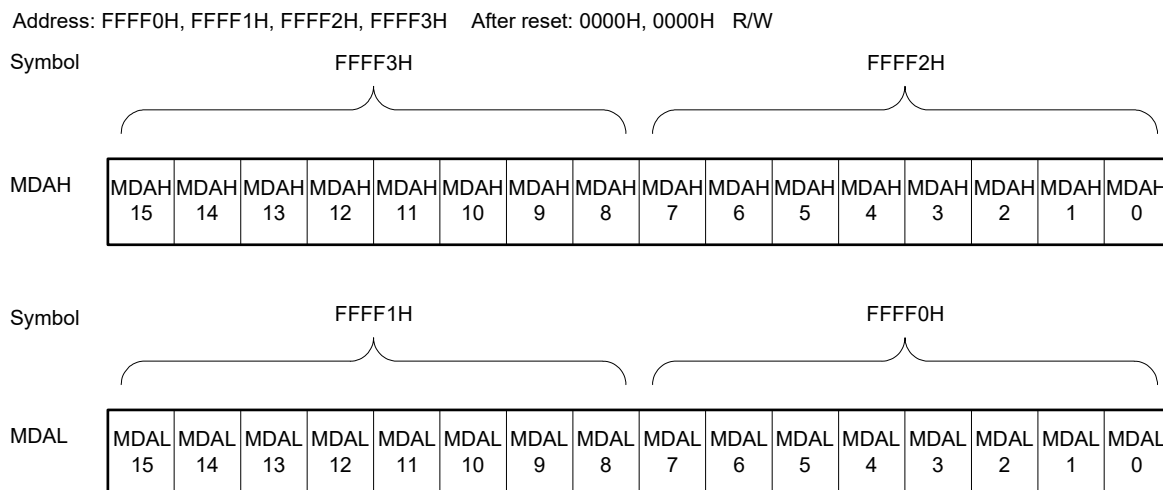

- Cautions**
1. Do not rewrite the MDAH and MDAL registers values during division operation processing (when the multiplication/division control register (MDUC) value is 81H or C1H). The operation will be executed in this case, but the operation result will be an undefined value.
 2. The MDAH and MDAL registers values read during division operation processing (when the MDUC register value is 81H or C1H) will not be guaranteed.
 3. The data is in the two's complement format in either the multiplication mode (signed) or multiply-accumulator mode (signed).

The following table shows the functions of the MDAH and MDAL registers during operation execution.

Table 14-2. Functions of MDAH and MDAL Registers During Operation Execution

Operation Mode	Setting	Operation Result
Multiplication mode (unsigned) Multiply-accumulator mode (unsigned)	MDAH: Multiplier (unsigned) MDAL: Multiplicand (unsigned)	–
Multiplication mode (signed) Multiply-accumulator mode (signed)	MDAH: Multiplier (signed) MDAL: Multiplicand (signed)	–
Division mode (unsigned)	MDAH: Dividend (unsigned) (higher 16 bits) MDAL: Dividend (unsigned) (lower 16 bits)	MDAH: Division result (unsigned) Higher 16 bits MDAL: Division result (unsigned) Lower 16 bits

14.2.2 Multiplication/division data register B (MDBL, MDBH)

The MDBH and MDBL registers set the values that are used for multiplication or division operation and store the operation result. They store the operation result (product) in the multiplication mode and multiply-accumulator mode, and set the divisor data in the division mode.

The MDBH and MDBL registers can be set by a 16-bit manipulation instruction.

Reset signal generation clears these registers to 0000H.

Figure 14-3. Format of Multiplication/Division Data Register B (MDBH, MDBL)

Address: FFFF4H, FFFF5H, FFFF6H, FFFF7H After reset: 0000H, 0000H R/W

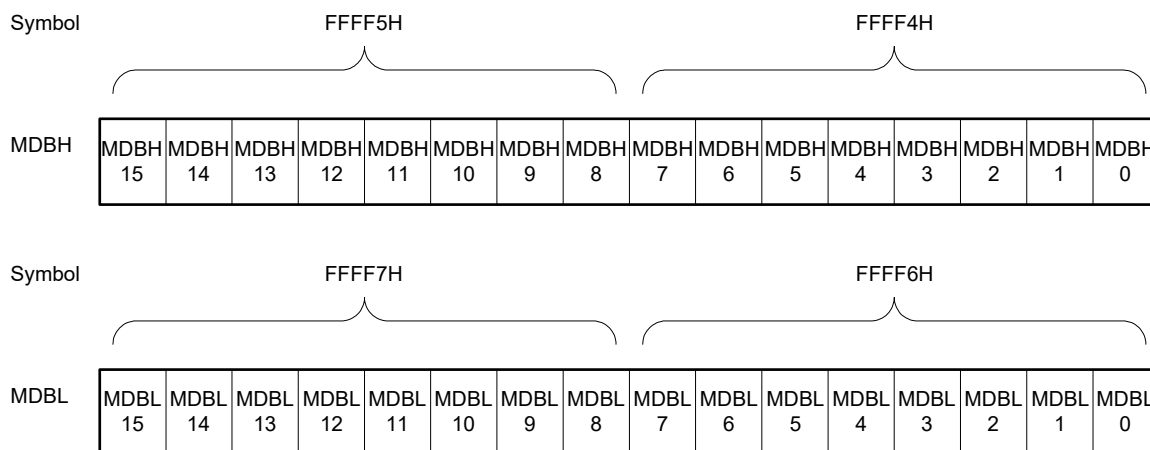

- Cautions 1. Do not rewrite the MDBH and MDBL registers values during division operation processing (when the multiplication/division control register (MDUC) value is 81H or C1H) or multiply-accumulation operation processing. The operation result will be an undefined value.**
- 2. Do not set the MDBH and MDBL registers to 0000H in the division mode. If they are set, the operation result will be an undefined value.**
- 3. The data is in the two's complement format in either the multiplication mode (signed) or multiply-accumulator mode (signed).**

The following table shows the functions of the MDBH and MDBL registers during operation execution.

Table 14-3. Functions of MDBH and MDBL Registers During Operation Execution

Operation Mode	Setting	Operation Result
Multiplication mode (unsigned) Multiply-accumulator mode (unsigned)	–	MDBH: Multiplication result (product) (unsigned) Higher 16 bits MDBL: Multiplication result (product) (unsigned) Lower 16 bits
Multiplication mode (signed) Multiply-accumulator mode (signed)	–	MDBH: Multiplication result (product) (signed) Higher 16 bits MDBL: Multiplication result (product) (signed) Lower 16 bits
Division mode (unsigned)	MDBH: Divisor (unsigned) (higher 16 bits) MDBL: Divisor (unsigned) (lower 16 bits)	–

14.2.3 Multiplication/division data register C (MDCL, MDCH)

The MDCH and MDCL registers are used to store the accumulated result while in the multiply-accumulator mode or the remainder of the operation result while in the division mode. These registers are not used while in the multiplication mode.

The MDCH and MDCL registers can be set by a 16-bit manipulation instruction.

Reset signal generation clears these registers to 0000H.

Figure 14-4. Format of Multiplication/Division Data Register C (MDCH, MDCL)

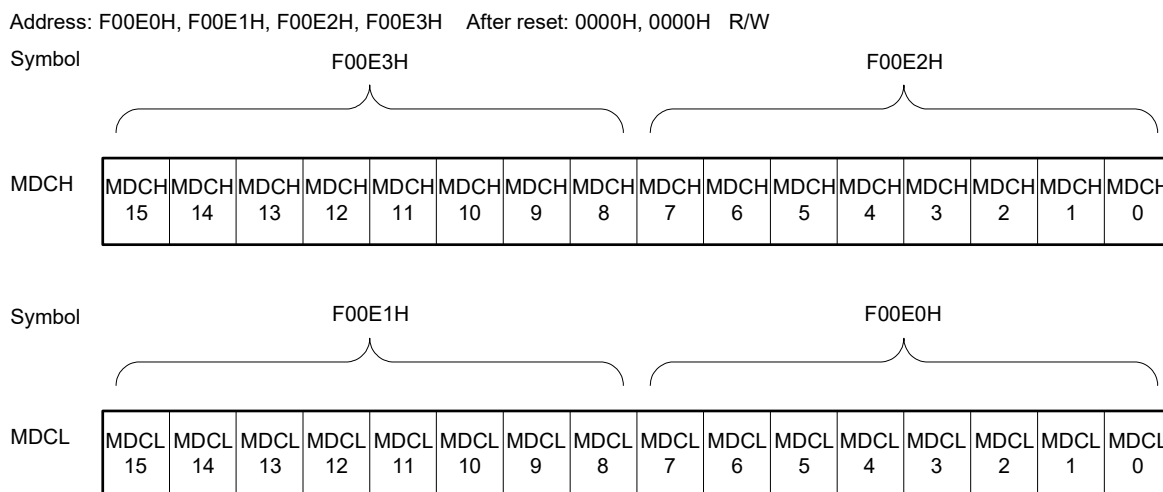

- Cautions**
1. The MDCH and MDCL registers values read during division operation processing (when the multiplication/division control register (MDUC) value is 81H or C1H) will not be guaranteed.
 2. During multiply-accumulator processing, do not use software to rewrite the values of the MDCH and MDCL registers. If this is done, the operation result will be undefined.
 3. The data is in the two's complement format in the multiply-accumulator mode (signed).

Table 14-4. Functions of MDCH and MDCL Registers During Operation Execution

Operation Mode	Setting	Operation Result
Multiplication mode (unsigned or signed)	–	–
Multiply-accumulator mode (unsigned)	MDCH: Initial accumulated value (unsigned) (higher 16 bits) MDCL: Initial accumulated value (unsigned) (lower 16 bits)	MDCH: accumulated value (unsigned) (higher 16 bits) MDCL: accumulated value (unsigned) (lower 16 bits)
Multiply-accumulator mode (signed)	MDCH: Initial accumulated value (signed) (higher 16 bits) MDCL: Initial accumulated value (signed) (lower 16 bits)	MDCH: accumulated value (signed) (higher 16 bits) MDCL: accumulated value (signed) (lower 16 bits)
Division mode (unsigned)	–	MDCH: Remainder (unsigned) (higher 16 bits) MDCL: Remainder (unsigned) (lower 16 bits)

The register configuration differs between when multiplication is executed and when division is executed, as follows.

- Register configuration during multiplication

<Multiplier A> <Multiplier B> <Product>

$$\text{MDAL (bits 15 to 0)} \times \text{MDAH (bits 15 to 0)} = [\text{MDBH (bits 15 to 0), MDBL (bits 15 to 0)}]$$

- Register configuration during multiply-accumulation

<Multiplier A> <Multiplier B> < accumulated value > < accumulated result >

$$\text{MDAL (bits 15 to 0)} \times \text{MDAH (bits 15 to 0)} + \text{MDC (bits 31 to 0)} = [\text{MDCH (bits 15 to 0), MDCL (bits 15 to 0)}]$$

(The multiplication result is stored in the MDBH (bits 15 to 0) and MDBL (bits 15 to 0).)

- Register configuration during division

<Dividend> <Divisor>

$$[\text{MDAH (bits 15 to 0), MDAL (bits 15 to 0)}] \div [\text{MDBH (bits 15 to 0), MDBL (bits 15 to 0)}] =$$

<Quotient> <Remainder>

$$[\text{MDAH (bits 15 to 0), MDAL (bits 15 to 0)}] \cdots [\text{MDCH (bits 15 to 0), MDCL (bits 15 to 0)}]$$

14.3 Register Controlling Multiplier and Divider/Multiply-Accumulator

The multiplier and divider/multiply-accumulator is controlled by using the multiplication/division control register (MDUC).

14.3.1 Multiplication/division control register (MDUC)

The MDUC register is an 8-bit register that controls the operation of the multiplier and divider/multiply-accumulator.

The MDUC register can be set by a 1-bit or 8-bit memory manipulation instruction.

Note that the overflow flag (MACOF) and sign flag (MACSF) of the multiply-accumulation result (accumulated) are read-only flags.

Reset signal generation clears this register to 00H.

Figure 14-5. Format of Multiplication/Division Control Register (MDUC)

Address: F00E8H After reset: 00H R/W ^{Note 1}

Symbol	<7>	<6>	5	4	<3>	<2>	<1>	<0>
MDUC	DIVMODE	MACMODE	0	0	MDSM	MACOF	MACSF	DIVST

DIVMODE	MACMODE	MDSM	Operation mode selection
0	0	0	Multiplication mode (unsigned) (default)
0	0	1	Multiplication mode (signed)
0	1	0	Multiply-accumulator mode (unsigned)
0	1	1	Multiply-accumulator mode (signed)
1	0	0	Division mode (unsigned), generation of a division completion interrupt (INTMD)
1	1	0	Division mode (unsigned), not generation of a division completion interrupt (INTMD)
Other than above			Setting prohibited

MACOF	Overflow flag of multiply-accumulation result (accumulated value)
0	No overflow
1	With over flow
<Set condition> <ul style="list-style-type: none"> For the multiply-accumulator mode (unsigned) The bit is set when the accumulated value goes outside the range from 00000000h to FFFFFFFFh. For the multiply-accumulator mode (signed) The bit is set when the result of adding a positive product to a positive accumulated value exceeds 7FFFFFFFh and is negative, or when the result of adding a negative product to a negative accumulated value exceeds 80000000h and is positive. 	

MACSF	Sign flag of multiply-accumulation result (accumulated value)
0	The accumulated value is positive.
1	The accumulated value is negative.
Multiply-accumulator mode (unsigned): The bit is always 0. Multiply-accumulator mode (signed): The bit indicates the sign bit of the accumulated value.	

DIVST ^{Note 2}	Division operation start/stop
0	Division operation processing complete
1	Starts division operation/division operation processing in progress

(Notes and Cautions are listed on the next page.)

Notes 1. Bits 1 and 2 are read-only bits.

- 2.** The DIVST bit can only be set (1) in the division mode. In the division mode, division operation is started by setting (1) the DIVST bit. The DIVST bit is automatically cleared (0) when the operation ends. In the multiplication mode, operation is automatically started by setting the multiplier and multiplicand to multiplication/division data register A (MDAH, MDAL), respectively.

Cautions 1. Do not rewrite the DIVMODE, MDSM bits during operation processing (while the DIVST bit is 1). If it is rewritten, the operation result will be an undefined value.

- 2.** The DIVST bit cannot be cleared (0) by using software during division operation processing (while the DIVST bit is 1).

14.4 Operations of Multiplier and Divider/Multiply-Accumulator

14.4.1 Multiplication (unsigned) operation

- Initial setting
 - <1> Set the multiplication/division control register (MDUC) to 00H.
 - <2> Set the multiplicand to multiplication/division data register A (L) (MDAL).
 - <3> Set the multiplier to multiplication/division data register A (H) (MDAH).
(There is no preference in the order of executing steps <2> and <3>. Multiplication operation is automatically started when the multiplier and multiplicand are set to the MDAH and MDAL registers, respectively.)
- During operation processing
 - <4> Wait for at least one clock. The operation will end when one clock has been issued.
- Operation end
 - <5> Read the product (lower 16 bits) from multiplication/division data register B (L) (MDBL).
 - <6> Read the product (higher 16 bits) from multiplication/division data register B (H) (MDBH).
(There is no preference in the order of executing steps <5> and <6>.)
- Next operation
 - <7> Start with the initial settings of each step to change the operation mode. When the same operation mode is used sequentially, settings <1> and <2> can be omitted.

Remark Steps <1> to <7> correspond to <1> to <7> in Figure 14-6.

Figure 14-6. Timing Diagram of Multiplication (Unsigned) Operation (2 × 3 = 6)

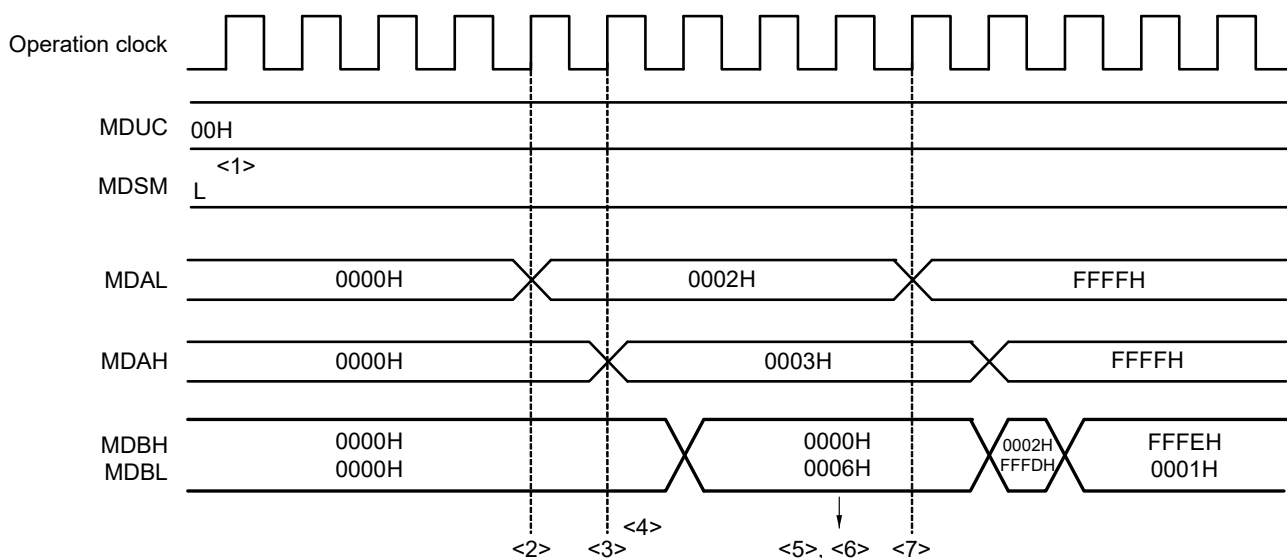

14.4.2 Multiplication (signed) operation

- Initial setting
 - <1> Set the multiplication/division control register (MDUC) to 08H.
 - <2> Set the multiplicand to multiplication/division data register A (L) (MDAL).
 - <3> Set the multiplier to multiplication/division data register A (H) (MDAH).
(There is no preference in the order of executing steps <2> and <3>. Multiplication operation is automatically started when the multiplier and multiplicand are set to the MDAH and MDAL registers, respectively.)
- During operation processing
 - <4> Wait for at least one clock. The operation will end when one clock has been issued.
- Operation end
 - <5> Read the product (lower 16 bits) from multiplication/division data register B (L) (MDBL).
 - <6> Read the product (higher 16 bits) from multiplication/division data register B (H) (MDBH).
(There is no preference in the order of executing steps <5> and <6>.)
- Next operation
 - <7> Start with the initial settings of each step to change the operation mode. When the same operation mode is used sequentially, settings <1> and <2> can be omitted.

Caution The data is in the two's complement format in multiplication mode (signed).

Remark Steps <1> to <7> correspond to <1> to <7> in Figure 14-7.

Figure 14-7. Timing Diagram of Multiplication (Signed) Operation ($-2 \times 32767 = -65534$)

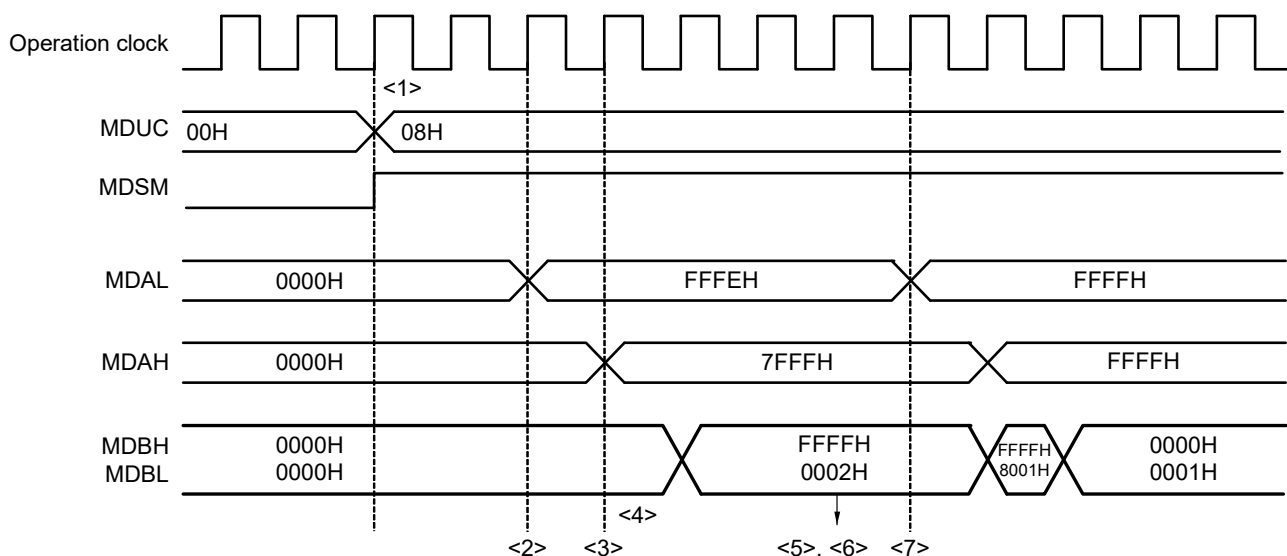

14.4.3 Multiply-accumulation (unsigned) operation

- Initial setting
 - <1> Set the multiplication/division control register (MDUC) to 40H.
 - <2> Set the initial accumulated value of higher 16 bits to multiplication/division data register C (L) (MDCL).
 - <3> Set the initial accumulated value of lower 16 bits to multiplication/division data register C (H) (MDCH).
 - <4> Set the multiplicand to multiplication/division data register A (L) (MDAL).
 - <5> Set the multiplier to multiplication/division data register A (H) (MDAH).
(There is no preference in the order of executing steps <2>, <3>, and <4>. Multiplication operation is automatically started when the multiplier is set to the MDAH register, respectively.)
- During operation processing
 - <6> The multiplication operation finishes in one clock cycle.
(The multiplication result is stored in multiplication/division data register B (L) (MDBL) and multiplication/division data register B (H) (MDBH).)
 - <7> After <6>, the multiply-accumulation operation finishes in one additional clock cycle. (There is a wait of at least two clock cycles after specifying the initial settings is finished (<5>).)
- Operation end
 - <8> Read the accumulated value (lower 16 bits) from the MDCL register.
 - <9> Read the accumulated value (higher 16 bits) from the MDCH register.
(There is no preference in the order of executing steps <8> and <9>.)
 - (<10> If the result of the multiply-accumulation operation causes an overflow, the MACOF bit is set to 1, INTMD signal is occurred.)
- Next operation
 - <11> Start with the initial settings of each step to change the operation mode. When the same operation mode is used sequentially, settings <1> to <4> can be omitted.

Remark Steps <1> to <10> correspond to <1> to <10> in Figure 14-8.

Figure 14-8. Timing Diagram of Multiply-Accumulation (Unsigned) Operation
 $(2 \times 3 + 3 = 9 \rightarrow 32767 \times 2 + 4294901762 = 0 \text{ (over flow generated)})$

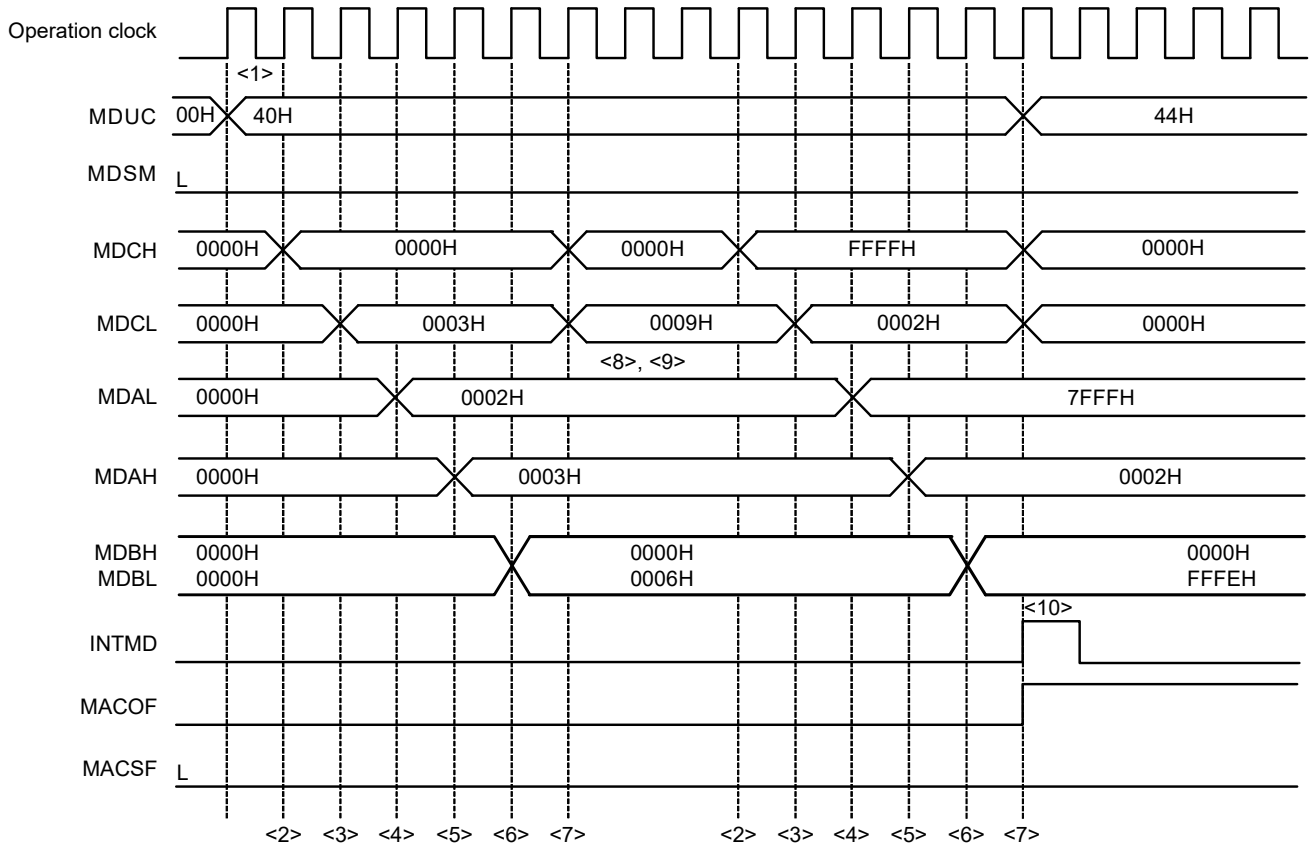

14.4.4 Multiply-accumulation (signed) operation

- Initial setting
 - <1> Set the multiplication/division control register (MDUC) to 48H.
 - <2> Set the initial accumulated value of higher 16 bits to multiplication/division data register C (H) (MDCH).
(<3> If the accumulated value in the MDCH register is negative, the MACSF bit is set to 1.)
 - <4> Set the initial accumulated value of lower 16 bits to multiplication/division data register C (L) (MDCL).
 - <5> Set the multiplicand to multiplication/division data register A (L) (MDAL).
 - <6> Set the multiplier to multiplication/division data register A (H) (MDAH).
(There is no preference in the order of executing steps <2>, <4>, and <5>. Multiplication operation is automatically started when the multiplier is set to the MDAH register of <6>, respectively.)
- During operation processing
 - <7> The multiplication operation finishes in one clock cycle.
(The multiplication result is stored in multiplication/division data register B (L) (MDBL) and multiplication/division data register B (H) (MDBH).)
 - <8> After <7>, the multiply-accumulation operation finishes in one additional clock cycle. (There is a wait of at least two clock cycles after specifying the initial settings is finished (<6>).)
- Operation end
 - <9> If the accumulated value stored in the MDCL and MDCH registers is positive, the MACSF bit is cleared to 0.
 - <10> Read the accumulated value (lower 16 bits) from the MDCL register.
 - <11> Read the accumulated value (higher 16 bits) from the MDCH register.
(There is no preference in the order of executing steps <10> and <11>.)
 - (<12> If the result of the multiply-accumulation operation causes an overflow, the MACOF bit is set to 1, INTMD signal is occurred.)
- Next operation
 - <13> Start with the initial settings of each step to change the operation mode. When the same operation mode is used sequentially, settings <1> to <5> can be omitted.

Caution The data is in the two's complement format in multiply-accumulation (signed) operation.

Remark Steps <1> to <12> correspond to <1> to <12> in Figure 14-9.

Figure 14-9. Timing Diagram of Multiply-Accumulation (signed) Operation
 $(2 \times 3 + (-4) = 2 \rightarrow 32767 \times (-1) + (-2147483647) = -2147450882$ (overflow occurs.)

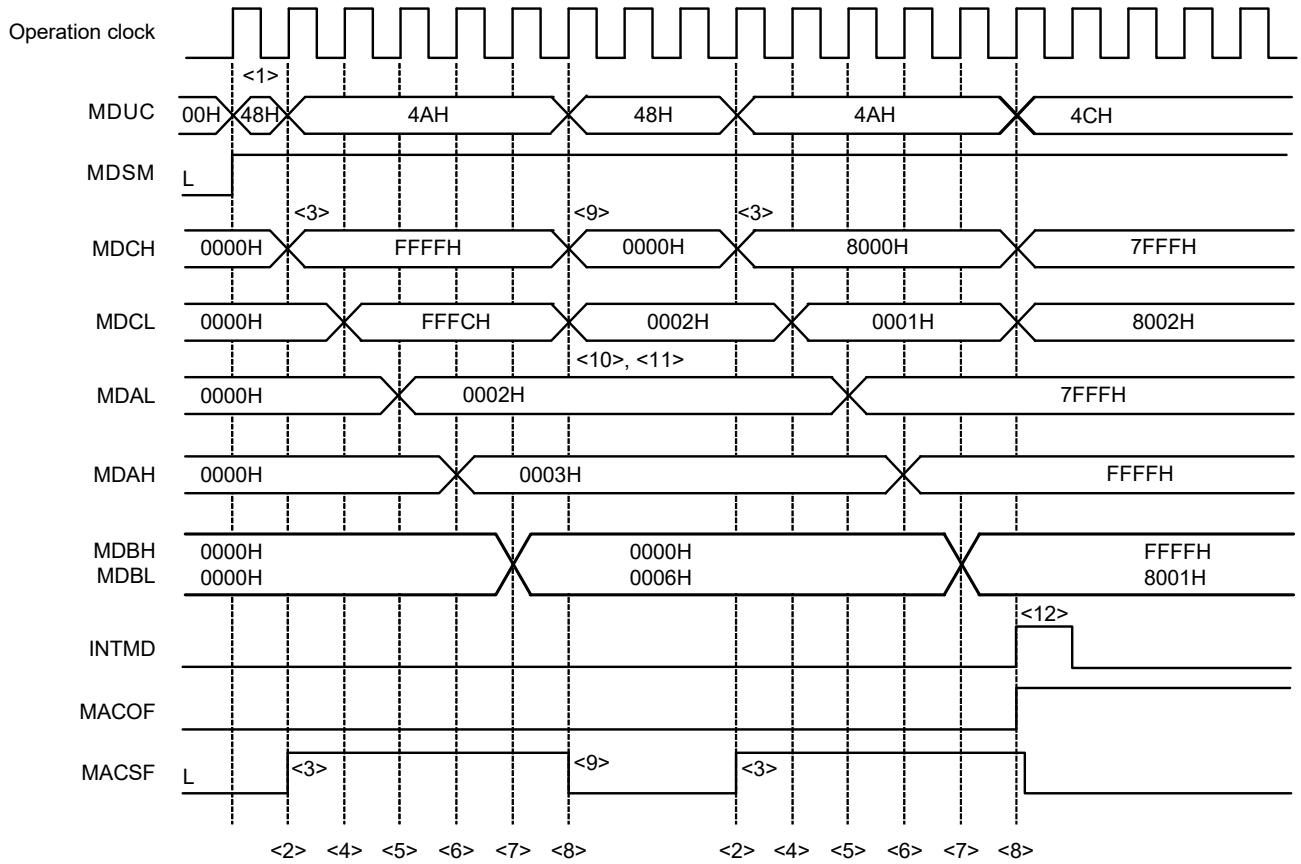

14.4.5 Division operation

- Initial setting
 - <1> Set the multiplication/division control register (MDUC) to 80H.
 - <2> Set the dividend (higher 16 bits) to multiplication/division data register A (H) (MDAH).
 - <3> Set the dividend (lower 16 bits) to multiplication/division data register A (L) (MDAL).
 - <4> Set the divisor (higher 16 bits) to multiplication/division data register B (H) (MDBH).
 - <5> Set the divisor (lower 16 bits) to multiplication/division data register B (L) (MDBL).
 - <6> Set bit 0 (DIVST) of the MDUC register to 1.
(There is no preference in the order of executing steps <2> to <5>.)
- During operation processing
 - <7> The operation will end when one of the following processing is completed.
 - A wait of at least 16 clocks (The operation will end when 16 clocks have been issued.)
 - A check whether the DIVST bit has been cleared
(The read values of the MDBL, MDBH, MDCL, and MDCH registers during operation processing are not guaranteed.)
- Operation end
 - <8> The DIVST bit is cleared and the operation ends. At this time, an interrupt request signal (INTMD) is generated if the operation was performed with MACMODE = 0.
 - <9> Read the quotient (lower 16 bits) from the MDAL register.
 - <10> Read the quotient (higher 16 bits) from the MDAH register.
 - <11> Read the remainder (lower 16 bits) from multiplication/division data register C (L) (MDCL).
 - <12> Read the remainder (higher 16 bits) from multiplication/division data register C (H) (MDCH).
(There is no preference in the order of executing steps <9> to <12>.)
- Next operation
 - <13> Start with the initial settings of each step to change the operation mode. When the same operation mode is used sequentially, settings <1> to <5> can be omitted.

Remark Steps <1> to <12> correspond to <1> to <12> in Figure 14-10.

Figure 14-10. Timing Diagram of Division Operation (Example: $35 \div 6 = 5$, Remainder 5)

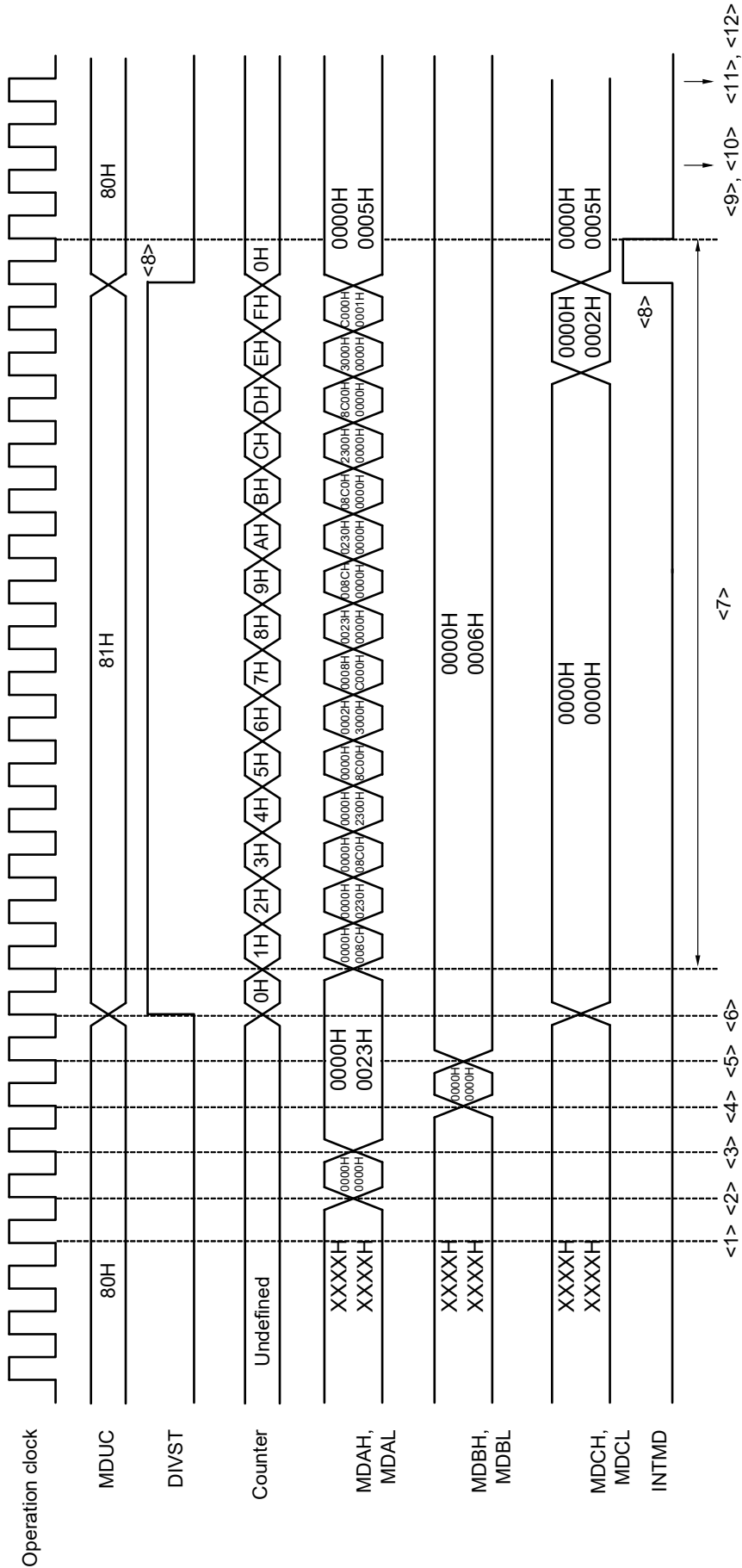

CHAPTER 15 DMA CONTROLLER

The RL78/G13 has an internal DMA (Direct Memory Access) controller.

Data can be automatically transferred between the peripheral hardware supporting DMA, SFRs, and internal RAM without via CPU.

As a result, the normal internal operation of the CPU and data transfer can be executed in parallel with transfer between the SFR and internal RAM, and therefore, a large capacity of data can be processed. In addition, real-time control using communication, timer, and A/D can also be realized.

15.1 Functions of DMA Controller

- Number of DMA channels: 2 channels (20, 24, 25, 30, 32, 36, 40, 44, 48, 52, or 64-pin products)
4 channels (80, 100, or 128-pin products)
- Transfer unit: 8 or 16 bits
- Maximum transfer unit: 1024 times
- Transfer type: 2-cycle transfer (One transfer is processed in 2 clocks and the CPU stops during that processing.)
- Transfer mode: Single-transfer mode
- Transfer request: Selectable from the following peripheral hardware interrupts
 - A/D converter
 - Serial interface
(CSI00, CSI01, CSI10, CSI11, CSI20, CSI21, CSI30, CSI31, UART0 to UART3)
 - Timer (channel 0, 1, 2, 3, 10, 11, 12, or 13)
- Transfer target: Between SFR and internal RAM

Here are examples of functions using DMA.

- Successive transfer of serial interface
- Consecutive capturing of A/D conversion results
- Capturing port value at fixed interval

15.2 Configuration of DMA Controller

The DMA controller includes the following hardware.

Table 15-1. Configuration of DMA Controller

Item	Configuration
Address registers	<ul style="list-style-type: none"> • DMA SFR address registers 0 to 3 (DSA0 to DSA3) • DMA RAM address registers 0 to 3 (DRA0 to DRA3)
Count register	<ul style="list-style-type: none"> • DMA byte count registers 0 to 3 (DBC0 to DBC3)
Control registers	<ul style="list-style-type: none"> • DMA mode control registers 0 to 3 (DMC0 to DMC3) • DMA operation control register 0 to 3 (DRC0 to DRC3)

15.2.1 DMA SFR address register n (DSAn)

This is an 8-bit register that is used to set an SFR address that is the transfer source or destination of DMA channel n. Set the lower 8 bits of the SFR addresses FFF00H to FFFFFH.

This register is not automatically incremented but fixed to a specific value.

In the 16-bit transfer mode, the least significant bit is ignored and is treated as an even address.

The DSAn register can be read or written in 8-bit units. However, it cannot be written during DMA transfer.

Reset signal generation clears this register to 00H.

Figure 15-1. Format of DMA SFR Address Register n (DSAn)

Address: FFFB0H (DSA0), FFFB1H (DSA1), F0200H (DSA2), F0201H (DSA3) After reset: 00H R/W

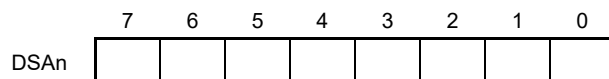

Remark n: DMA channel number (n = 0 to 3)

15.2.2 DMA RAM address register n (DRAn)

This is a 16-bit register that is used to set a RAM address that is the transfer source or destination of DMA channel n. Addresses of the internal RAM area other than the general-purpose registers (see table 15-2) can be set to this register. Set the lower 16 bits of the RAM address.

This register is automatically incremented when DMA transfer has been started. It is incremented by +1 in the 8-bit transfer mode and by +2 in the 16-bit transfer mode. DMA transfer is started from the address set to this DRAn register. When the data of the last address has been transferred, the DRAn register stops with the value of the last address +1 in the 8-bit transfer mode, and the last address +2 in the 16-bit transfer mode.

In the 16-bit transfer mode, the least significant bit is ignored and is treated as an even address. The DRAn register can be read or written in 8-bit or 16-bit units. However, it cannot be written during DMA transfer. Reset signal generation clears this register to 0000H.

Figure 15-2. Format of DMA RAM Address Register n (DRAn)

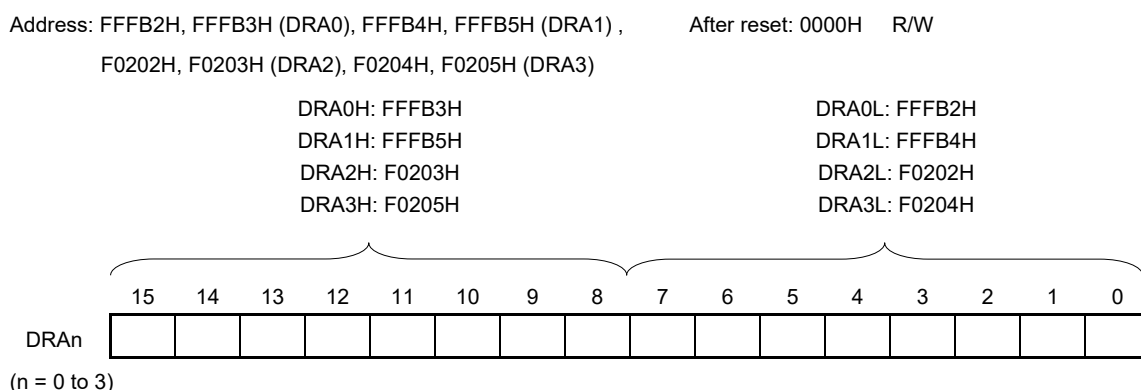

Table 15-2. Internal RAM Area other than the General-purpose Registers

Part Number	Internal RAM Area other than the General-purpose Registers
R5F100xA, R5F101xA (x = 6 to 8, A to C, E to G), R5F100xC, R5F101xC (x = 6 to 8, A to C, E to G, J, L)	FF700H to FFEDFH
R5F100xD, R5F101xD (x = 6 to 8, A to C, E to G, J, L)	FF300H to FFEDFH
R5F100xE, R5F101xE (x = 6 to 8, A to C, E to G, J, L)	FEF00H to FFEDFH
R5F100xF, R5F101xF (x = A to C, E to G, J, L, M, P)	FD00H to FFEDFH
R5F100xG, R5F101xG (x = A to C, E to G, J, L, M, P)	FCF00H to FFEDFH
R5F100xH, R5F101xH (x = E to G, J, L, M, P, S)	FBF00H to FFEDFH
R5F100xJ, R5F101xJ (x = F, G, J, L, M, P, S)	FAF00H to FFEDFH
R5F100xK, R5F101xK (x = F, G, J, L, M, P, S)	F9F00H to FFEDFH
R5F100xL, R5F101xL (x = F, G, J, L, M, P, S)	F7F00H to FFEDFH

Remark n: DMA channel number (n = 0 to 3)

15.2.3 DMA byte count register n (DBCn)

This is a 10-bit register that is used to set the number of times DMA channel n executes transfer. Be sure to set the number of times of transfer to this DBCn register before executing DMA transfer (up to 1024 times).

Each time DMA transfer has been executed, this register is automatically decremented. By reading this DBCn register during DMA transfer, the remaining number of times of transfer can be learned.

The DBCn register can be read or written in 8-bit or 16-bit units. However, it cannot be written during DMA transfer. Reset signal generation clears this register to 0000H.

Figure 15-3. Format of DMA Byte Count Register n (DBCn)

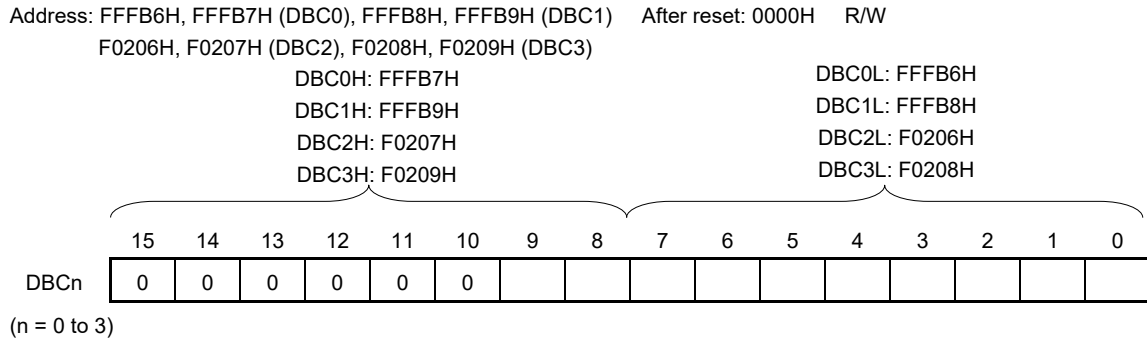

DBCn[9:0]	Number of Times of Transfer (When DBCn is Written)	Remaining Number of Times of Transfer (When DBCn is Read)
000H	1024	Completion of transfer or waiting for 1024 times of DMA transfer
001H	1	Waiting for remaining one time of DMA transfer
002H	2	Waiting for remaining two times of DMA transfer
003H	3	Waiting for remaining three times of DMA transfer
•	•	•
•	•	•
•	•	•
3FEH	1022	Waiting for remaining 1022 times of DMA transfer
3FFH	1023	Waiting for remaining 1023 times of DMA transfer

- Cautions**
1. Be sure to clear bits 15 to 10 to “0”.
 2. If the general-purpose register is specified or the internal RAM space is exceeded as a result of continuous transfer, the general-purpose register or SFR space are written or read, resulting in loss of data in these spaces. Be sure to set the number of times of transfer that is within the internal RAM space.

Remark n: DMA channel number (n = 0 to 3)

15.3 Registers Controlling DMA Controller

DMA controller is controlled by the following registers.

- DMA mode control register n (DMCn)
- DMA operation control register n (DRCn)

Remark n: DMA channel number (n = 0 to 3)

15.3.1 DMA mode control register n (DMCn)

The DMCn register is a register that is used to set a transfer mode of DMA channel n. It is used to select a transfer direction, data size, setting of pending, and start source. Bit 7 (STGn) is a software trigger that starts DMA.

Rewriting bits 6, 5, and 3 to 0 of the DMCn register is prohibited during operation (when DSTn = 1).

The DMCn register can be set by a 1-bit or 8-bit memory manipulation instruction.

Reset signal generation clears this register to 00H.

Figure 15-4. Format of DMA Mode Control Register n (DMCn) (1/3)

Address: FFFBAH (DMC0), FFFBBH (DMC1), F020AH (DMC2), F020BH (DMC3) After reset: 00H R/W

Symbol	<7>	<6>	<5>	<4>	3	2	1	0
DMCn	STGn	DRSn	DSn	DWAITn	IFCn3	IFCn2	IFCn1	IFCn0

STGn ^{Note 1}	DMA transfer start software trigger
0	No trigger operation
1	DMA transfer is started when DMA operation is enabled (DENn = 1).
DMA transfer is performed once by writing 1 to the STGn bit when DMA operation is enabled (DENn = 1). When this bit is read, 0 is always read.	

DRSn	Selection of DMA transfer direction
0	SFR to internal RAM
1	Internal RAM to SFR

DSn	Specification of transfer data size for DMA transfer
0	8 bits
1	16 bits

DWAITn ^{Note 2}	Pending of DMA transfer
0	Executes DMA transfer upon DMA start request (not held pending).
1	Holds DMA start request pending if any.
DMA transfer that has been held pending can be started by clearing the value of the DWAITn bit to 0. It takes 2 clocks to actually hold DMA transfer pending when the value of the DWAITn bit is set to 1.	

- Notes**
1. The software trigger (STGn) can be used regardless of the IFCn0 to IFCn3 bits values.
 2. When DMA transfer is held pending while using two or more DMA channels, be sure to hold the DMA transfer pending for all channels (by setting the DWAIT0, DWAIT1, DWAIT2, and DWAIT3 bits to 1).

Remark n: DMA channel number (n = 0 to 3)

Figure 15-4. Format of DMA Mode Control Register n (DMCn) (2/3)

Address: FFFBAH (DMC0), FFFBBH (DMC1) After reset: 00H R/W

Symbol	<7>	<6>	<5>	<4>	3	2	1	0
DMCn	STGn	DRSn	DSn	DWAITn	IFCn3	IFCn2	IFCn1	IFCn0

(When n = 0 or 1)

IFCn 3	IFCn 2	IFCn 1	IFCn 0	Selection of DMA start source ^{Note}	
				Trigger signal	Trigger contents
0	0	0	0	–	Disables DMA transfer by interrupt. (Only software trigger is enabled.)
0	0	0	1	INTAD	A/D conversion end interrupt
0	0	1	0	INTTM00	End of timer channel 00 count or capture end interrupt
0	0	1	1	INTTM01	End of timer channel 01 count or capture end interrupt
0	1	0	0	INTTM02	End of timer channel 02 count or capture end interrupt
0	1	0	1	INTTM03	End of timer channel 03 count or capture end interrupt
0	1	1	0	INTST0/INTCSI00	UART0 transmission transfer end or buffer empty interrupt/CSI00 transfer end or buffer empty interrupt
0	1	1	1	INTSR0/INTCSI01	UART0 reception transfer end interrupt/CSI01 transfer end or buffer empty interrupt
1	0	0	0	INTST1/INTCSI10	UART1 transmission transfer end or buffer empty interrupt/CSI10 transfer end or buffer empty interrupt
1	0	0	1	INTSR1/INTCSI11	UART1 reception transfer end interrupt/CSI11 transfer end or buffer empty interrupt
1	0	1	0	INTST2/INTCSI20	UART2 transmission transfer end or buffer empty interrupt/CSI20 transfer end or buffer empty interrupt
1	0	1	1	INTSR2/INTCSI21	UART2 reception transfer end interrupt/CSI21 transfer end or buffer empty interrupt
Other than above				Setting prohibited	

Note The software trigger (STGn) can be used regardless of the IFCn0 to IFCn3 bits values.

Remark n: DMA channel number (n = 0, 1)

Figure 15-4. Format of DMA Mode Control Register n (DMCn) (3/3)

Address: F020AH (DMC2), F020BH (DMC3) After reset: 00H R/W

Symbol	<7>	<6>	<5>	<4>	3	2	1	0
DMCn	STGn	DRSn	DSn	DWAITn	IFCn3	IFCn2	IFCn1	IFCn0

(When n = 2 or 3)

IFCn 3	IFCn 2	IFCn 1	IFCn 0	Selection of DMA start source ^{Note}	
				Trigger signal	Trigger contents
0	0	0	0	–	Disables DMA transfer by interrupt. (Only software trigger is enabled.)
0	0	0	1	INTAD	A/D conversion end interrupt
0	0	1	0	INTTM10	End of timer channel 10 count or capture end interrupt
0	0	1	1	INTTM11	End of timer channel 11 count or capture end interrupt
0	1	0	0	INTTM12	End of timer channel 12 count or capture end interrupt
0	1	0	1	INTTM13	End of timer channel 13 count or capture end interrupt
0	1	1	0	INTST3/INTCSI30	UART3 transmission transfer end or buffer empty interrupt/CSI30 transfer end or buffer empty interrupt
0	1	1	1	INTSR3/INTCSI31	UART3 reception transfer end interrupt/CSI31 transfer end or buffer empty interrupt
1	0	0	0	INTST1/INTCSI10	UART1 transmission transfer end or buffer empty interrupt/CSI10 transfer end or buffer empty interrupt
1	0	0	1	INTSR1/INTCSI11	UART1 reception transfer end interrupt/CSI11 transfer end or buffer empty interrupt
1	0	1	0	INTST2/INTCSI20	UART2 transmission transfer end or buffer empty interrupt/CSI20 transfer end or buffer empty interrupt
1	0	1	1	INTSR2/INTCSI21	UART2 reception transfer end interrupt/CSI21 transfer end or buffer empty interrupt
Other than above				Setting prohibited	

Note The software trigger (STGn) can be used regardless of the IFCn0 to IFCn3 bits values.

Remark n: DMA channel number (n = 2, 3)

15.3.2 DMA operation control register n (DRCn)

The DRCn register is a register that is used to enable or disable transfer of DMA channel n. Rewriting bit 7 (DENn) of this register is prohibited during operation (when DSTn = 1). The DRCn register can be set by a 1-bit or 8-bit memory manipulation instruction. Reset signal generation clears this register to 00H.

Figure 15-5. Format of DMA Operation Control Register n (DRCn)

Address: FFFBCH (DRC0), FFFBDH (DRC1), F020CH (DRC2), F020DH (DRC3) After reset: 00H R/W

Symbol	<7>	6	5	4	3	2	1	<0>
DRCn	DENn	0	0	0	0	0	0	DSTn

DENn	DMA operation enable flag
0	Disables operation of DMA channel n (stops operating clock of DMA).
1	Enables operation of DMA channel n.
DMAC waits for a DMA trigger when DSTn = 1 after DMA operation is enabled (DENn = 1).	

DSTn	DMA transfer mode flag
0	DMA transfer of DMA channel n is completed.
1	DMA transfer of DMA channel n is not completed (still under execution).
DMAC waits for a DMA trigger when DSTn = 1 after DMA operation is enabled (DENn = 1). When a software trigger (STGn) or the start source trigger set by the IFCn3 to IFCn0 bits is input, DMA transfer is started. When DMA transfer is completed after that, this bit is automatically cleared to 0. Write 0 to this bit to forcibly terminate DMA transfer under execution.	

Caution The DSTn flag is automatically cleared to 0 when a DMA transfer is completed. Writing the DENn flag is enabled only when DSTn = 0. When a DMA transfer is terminated without waiting for generation of the interrupt (INTDMAn) of DMAn, therefore, set the DSTn bit to 0 and then the DENn bit to 0 (for details, refer to 15.5.5 Forced termination by software).

Remark n: DMA channel number (n = 0 to 3)

15.4 Operation of DMA Controller

15.4.1 Operation procedure

- <1> The DMA controller is enabled to operate when DENn = 1. Before writing the other registers, be sure to set the DENn bit to 1. Use 80H to write with an 8-bit manipulation instruction.
- <2> Set an SFR address, a RAM address, the number of times of transfer, and a transfer mode of DMA transfer to DMA SFR address register n (DSAn), DMA RAM address register n (DRAn), DMA byte count register n (DBCn), and DMA mode control register n (DMCn).
- <3> The DMA controller waits for a DMA trigger when DSTn = 1. Use 81H to write with an 8-bit manipulation instruction.
- <4> When a software trigger (STGn) or a start source trigger specified by the IFCn3 to IFCn0 bits is input, a DMA transfer is started.
- <5> Transfer is completed when the number of times of transfer set by the DBCn register reaches 0, and transfer is automatically terminated by occurrence of an interrupt (INTDMA_n).
- <6> Stop the operation of the DMA controller by clearing the DENn bit to 0 when the DMA controller is not used.

Figure 15-6. Operation Procedure

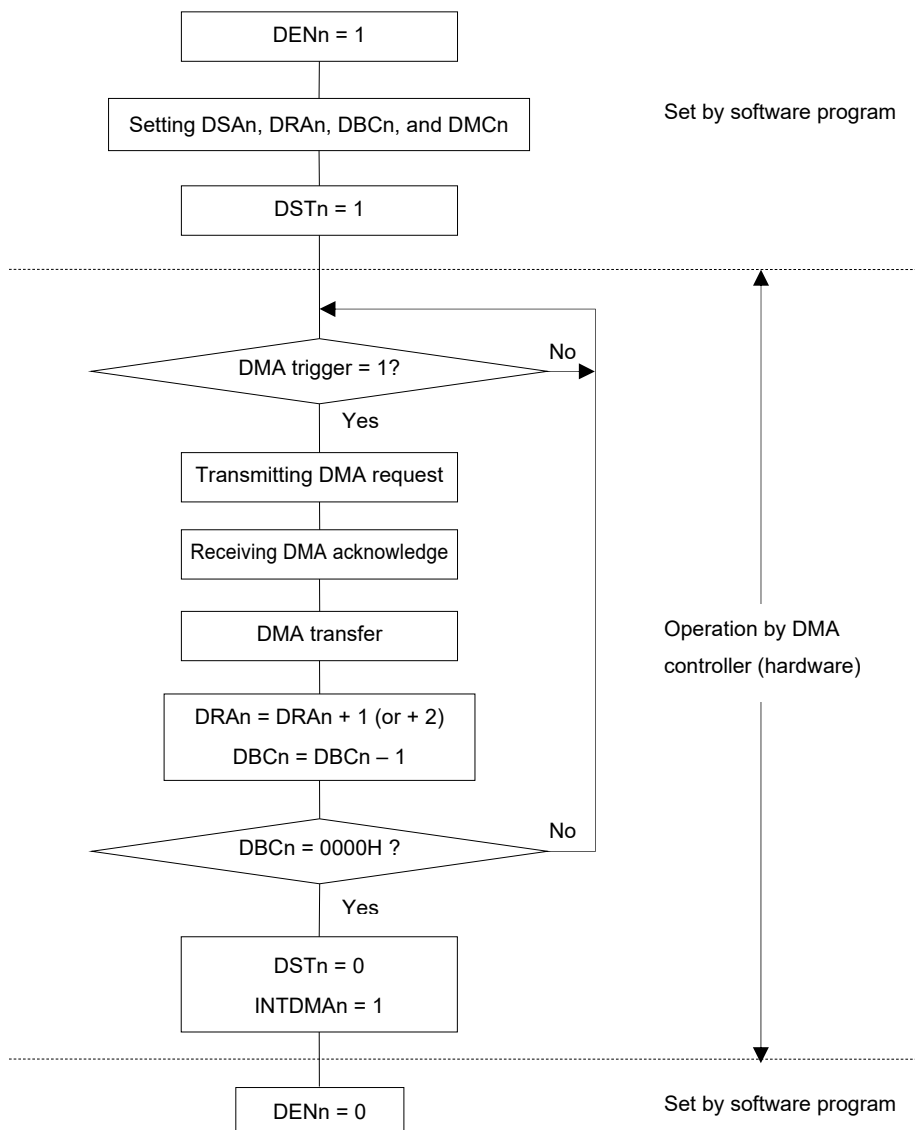

Remark n: DMA channel number (n = 0 to 3)

15.4.2 Transfer mode

The following four modes can be selected for DMA transfer by using bits 6 and 5 (DRSn and DS_n) of DMA mode control register n (DMCn).

DRSn	DS _n	DMA Transfer Mode
0	0	Transfer from SFR of 1-byte data (fixed address) to RAM (address is incremented by +1)
0	1	Transfer from SFR of 2-byte data (fixed address) to RAM (address is incremented by +2)
1	0	Transfer from RAM of 1-byte data (address is incremented by +1) to SFR (fixed address)
1	1	Transfer from RAM of 2-byte data (address is incremented by +2) to SFR (fixed address)

By using these transfer modes, up to 1024 bytes of data can be consecutively transferred by using the serial interface, data resulting from A/D conversion can be consecutively transferred, and port data can be scanned at fixed time intervals by using a timer.

15.4.3 Termination of DMA transfer

When DBCn = 00H and DMA transfer is completed, the DSTn bit is automatically cleared to 0. An interrupt request (INTDMA_n) is generated and transfer is terminated.

When the DSTn bit is cleared to 0 to forcibly terminate DMA transfer, DMA byte count register n (DBCn) and DMA RAM address register n (DRAn) hold the value when transfer is terminated.

The interrupt request (INTDMA_n) is not generated if transfer is forcibly terminated.

Remark n: DMA channel number (n = 0 to 3)

15.5 Example of Setting of DMA Controller

15.5.1 Simplified SPI (CSI) consecutive transmission

A flowchart showing an example of setting for simplified SPI (CSI) consecutive transmission is shown below.

- Consecutive transmission of CSI10 (256 bytes)
- DMA channel 0 is used for DMA transfer.
- DMA start source: INTCSI10 (software trigger (STG0) only for the first start source)
- Interrupt of CSI10 is specified by IFC03 to IFC00 = 1000B.
- Transfers FFB00H to FFBFFH (256 bytes) of RAM to FFF44H of the data register (SIO10) of simplified SPI (CSI).

Remark IFC03 to IFC00: Bits 3 to 0 of DMA mode control registers 0 (DMC0)

Figure 15-7. Example of Setting for Simplified SPI (CSI) Consecutive Transmission

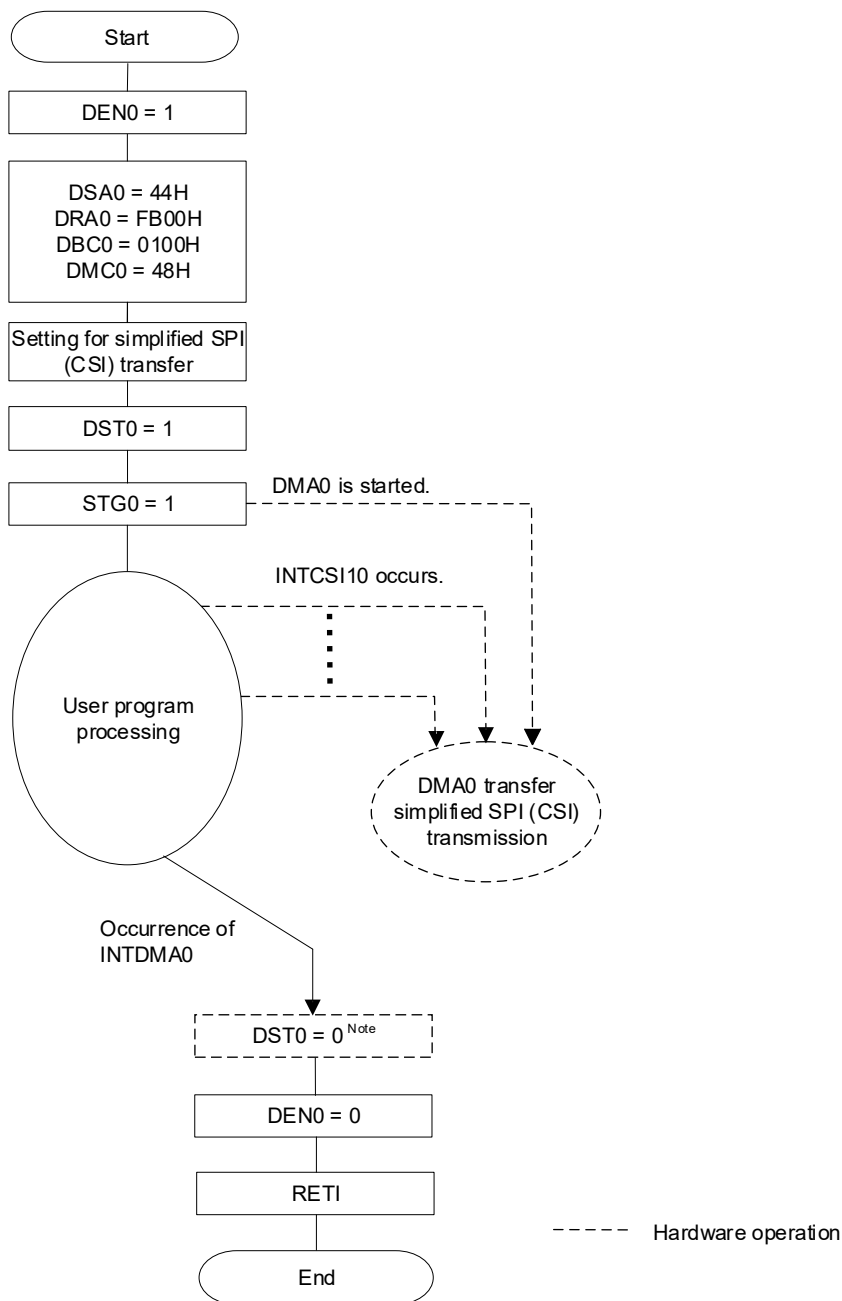

Note The DST0 flag is automatically cleared to 0 when a DMA transfer is completed. Writing the DEN0 flag is enabled only when DST0 = 0. To terminate a DMA transfer without waiting for occurrence of the interrupt of DMA0 (INTDMA0), set the DST0 bit to 0 and then the DEN0 bit to 0 (for details, refer to 15.5.5 Forced termination by software).

The first trigger for consecutive transmission is not started by the interrupt of simplified SPI (CSI). In this example, it starts by a software trigger.

Simplified SPI (CSI) transmission of the second time and onward is automatically executed.

A DMA interrupt (INTDMA0) occurs when the last transmit data has been written to the data register.

15.5.2 Consecutive capturing of A/D conversion results

A flowchart of an example of setting for consecutively capturing A/D conversion results is shown below.

- Consecutive capturing of A/D conversion results.
- DMA channel 1 is used for DMA transfer.
- DMA start source: INTAD
- Interrupt of A/D is specified by IFC13 to IFC10 = 0001B.
- Transfers FFF1EH and FFF1FH (2 bytes) of the 10-bit A/D conversion result register (ADCR) to 512 bytes of FFCE0H to FFEDFH of RAM.

Remark IFC13 to IFC10: Bits 3 to 0 of DMA mode control registers 1 (DMC1)

Figure 15-8. Example of Setting of Consecutively Capturing A/D Conversion Results

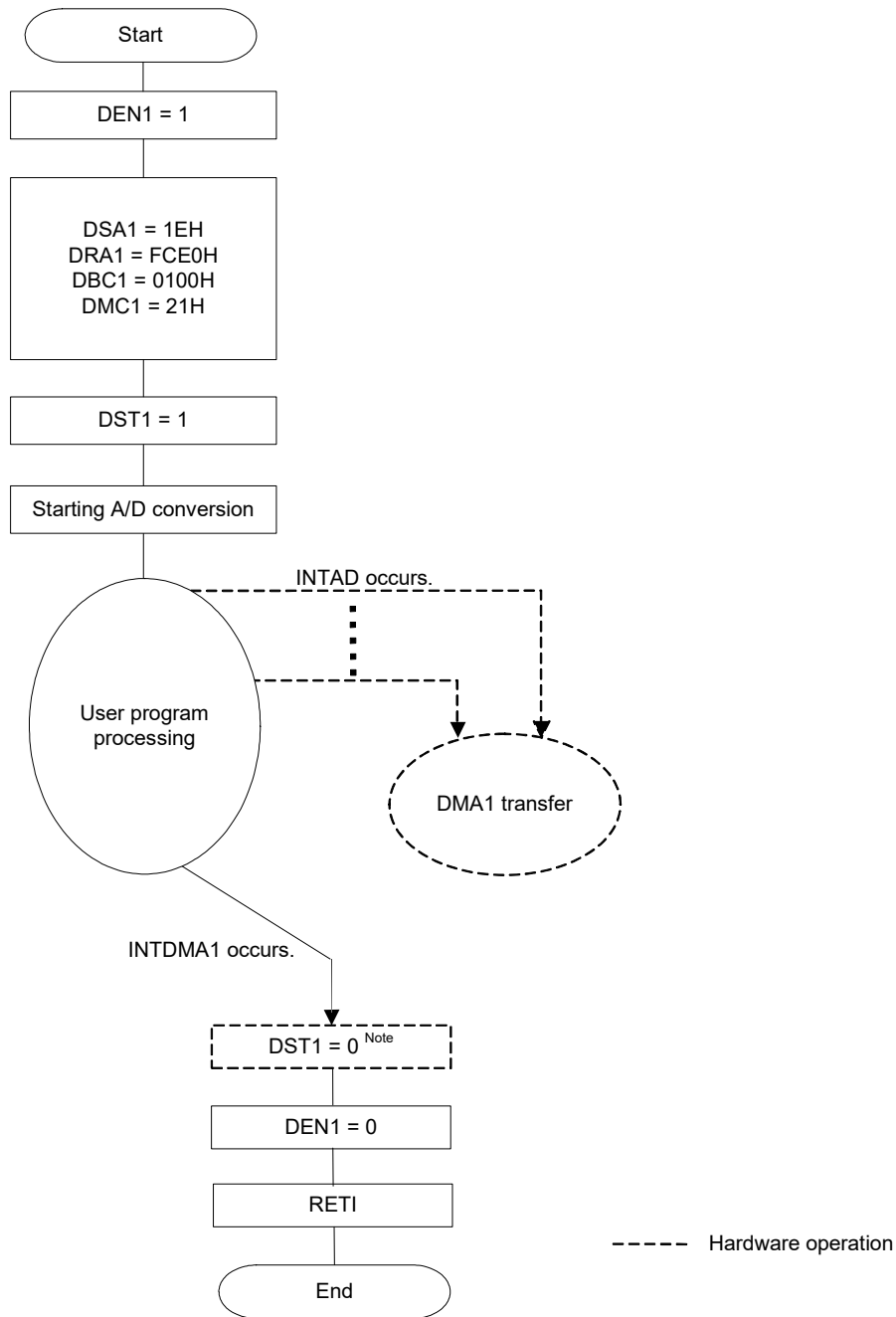

Note The DST1 flag is automatically cleared to 0 when a DMA transfer is completed. Writing the DEN1 flag is enabled only when DST1 = 0. To terminate a DMA transfer without waiting for occurrence of the interrupt of DMA1 (INTDMA1), set the DST1 bit to 0 and then the DEN1 bit to 0 (for details, refer to **15.5.5 Forced termination by software**).

15.5.3 UART consecutive reception + ACK transmission

A flowchart illustrating an example of setting for UART consecutive reception + ACK transmission is shown below.

- Consecutively receives data from UART0 and outputs ACK to P10 on completion of reception.
- DMA channel 0 is used for DMA transfer.
- DMA start source: Software trigger (DMA transfer on occurrence of an interrupt is disabled.)
- Transfers FFF12H of UART receive data register 0 (RXD0) to 64 bytes of FFE00H to FFE3FH of RAM.

Figure 15-9. Example of Setting for UART Consecutive Reception + ACK Transmission

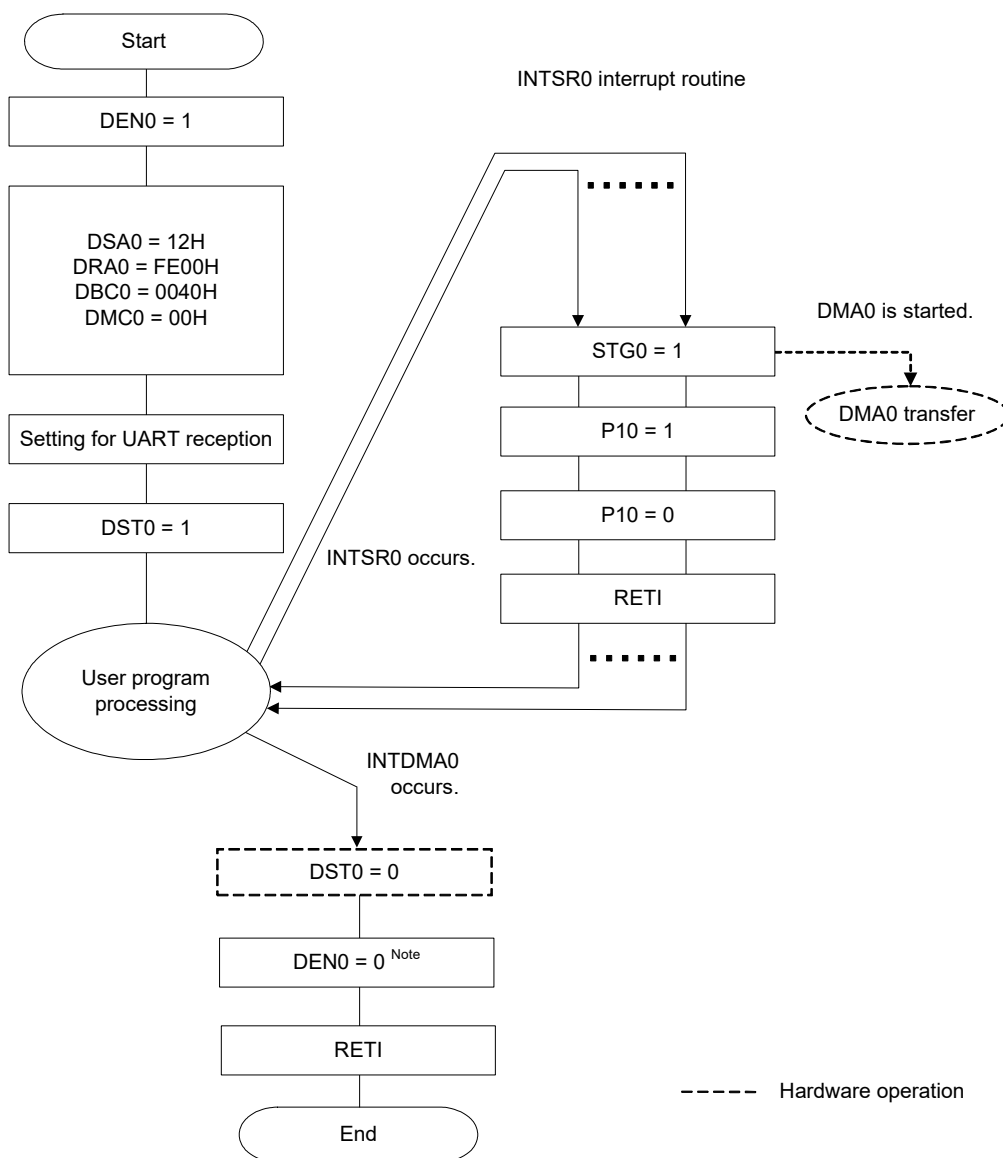

Note The DST0 flag is automatically cleared to 0 when a DMA transfer is completed. Writing the DEN0 flag is enabled only when DST0 = 0. To terminate a DMA transfer without waiting for occurrence of the interrupt of DMA0 (INTDMA0), set the DST0 bit to 0 and then the DEN0 bit to 0 (for details, refer to **15.5.5 Forced termination by software**).

Remark This is an example where a software trigger is used as a DMA start source. If ACK is not transmitted and if only data is consecutively received from UART, the UART reception end interrupt (INTSR0) can be used to start DMA for data reception.

15.5.4 Holding DMA transfer pending by DWAITn bit

When DMA transfer is started, transfer is performed while an instruction is executed. At this time, the operation of the CPU is stopped and delayed for the duration of 2 clocks. If this poses a problem to the operation of the set system, a DMA transfer can be held pending by setting the DWAITn bit to 1. The DMA transfer for a transfer trigger that occurred while DMA transfer was held pending is executed after the pending status is canceled. However, because only one transfer trigger can be held pending for each channel, even if multiple transfer triggers occur for one channel during the pending status, only one DMA transfer is executed after the pending status is canceled.

To output a pulse with a width of 10 clocks of the operating frequency from the P10 pin, for example, the clock width increases to 12 if a DMA transfer is started midway. In this case, the DMA transfer can be held pending by setting the DWAITn bit to 1.

After setting the DWAITn bit to 1, it takes two clocks until a DMA transfer is held pending.

Figure 15-10. Example of Setting for Holding DMA Transfer Pending by DWAITn Bit

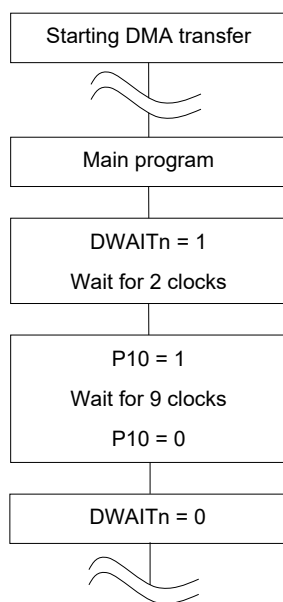

Caution When DMA transfer is held pending while using two or more DMA channels, be sure to held the DMA transfer pending for all channels (by setting DWAIT0, DWAIT1, DWAIT2, and DWAIT3 to 1). If the DMA transfer of one channel is executed while that of the other channel is held pending, DMA transfer might not be held pending for the latter channel.

- Remarks**
1. n: DMA channel number (n = 0 to 3)
 2. 1 clock: 1/f_{CLK} (f_{CLK}: CPU clock)

15.5.5 Forced termination by software

After the DSTn bit is set to 0 by software, it takes up to 2 clocks until a DMA transfer is actually stopped and the DSTn bit is set to 0. To forcibly terminate a DMA transfer by software without waiting for occurrence of the interrupt (INTDMA_n) of DMA_n, therefore, perform either of the following processes.

<When using one DMA channel>

- Set the DSTn bit to 0 (use DRCn = 80H to write with an 8-bit manipulation instruction) by software, confirm by polling that the DSTn bit has actually been cleared to 0, and then set the DENn bit to 0 (use DRCn = 00H to write with an 8-bit manipulation instruction).
- Set the DSTn bit to 0 (use DRCn = 80H to write with an 8-bit manipulation instruction) by software and then set the DENn bit to 0 (use DRCn = 00H to write with an 8-bit manipulation instruction) two or more clocks after.

<When using two or more DMA channels>

- To forcibly terminate DMA transfer by software when using two or more DMA channels (by setting DSTn to 0), clear the DSTn bit to 0 after the DMA transfer is held pending by setting the DWAITn bits of all using channels to 1. Next, clear the DWAITn bits of all using channels to 0 to cancel the pending status, and then clear the DENn bit to 0.

Figure 15-11. Forced Termination of DMA Transfer (1/2)

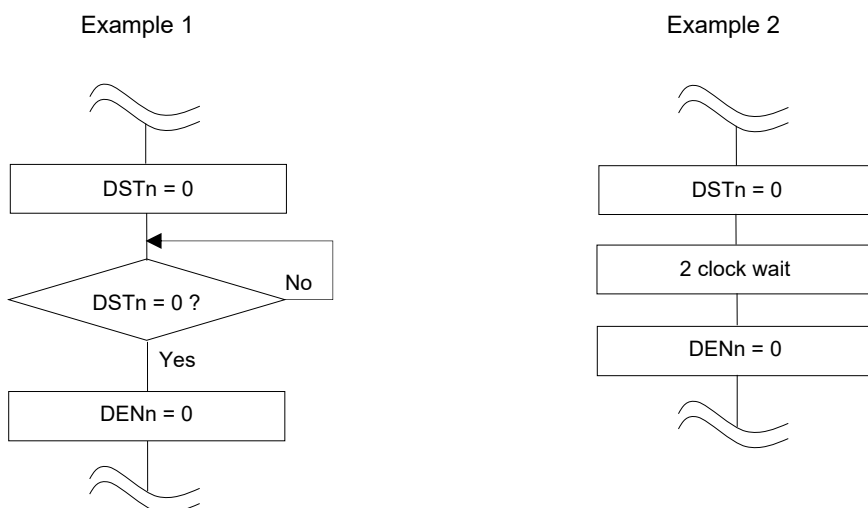

- Remarks**
1. n: DMA channel number (n = 0 to 3)
 2. 1 clock: 1/f_{CLK} (f_{CLK}: CPU clock)

Figure 15-11. Forced Termination of DMA Transfer (2/2)

Example 3

- Procedure for forcibly terminating the DMA transfer for one channel if both channels are used

- Procedure for forcibly terminating the DMA transfer for both channels if both channels are used

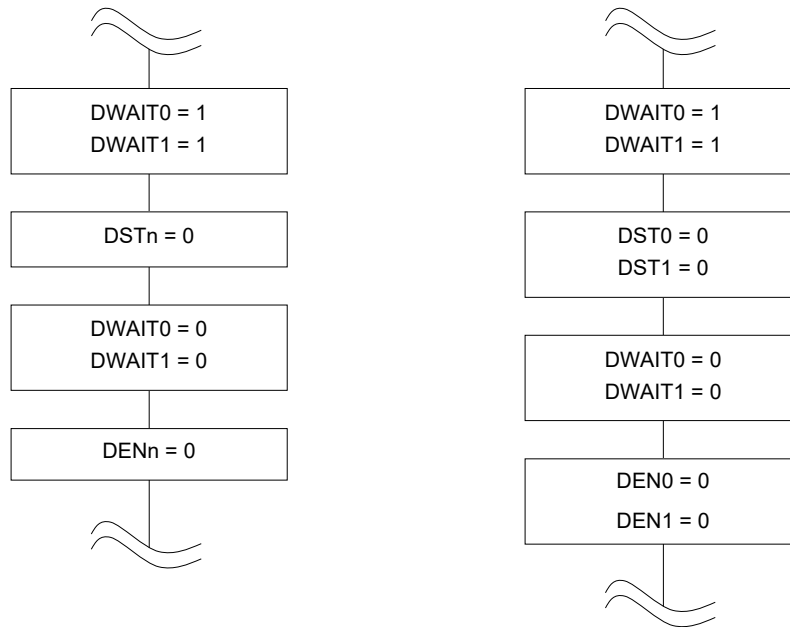

Caution In example 3, the system is not required to wait two clock cycles after the DWAITn bit is set to 1. In addition, the system does not have to wait two clock cycles after clearing the DSTn bit to 0, because more than two clock cycles elapse from when the DSTn bit is cleared to 0 to when the DENn bit is cleared to 0.

- Remarks**
1. n: DMA channel number (n = 0, 1)
 2. 1 clock: $1/f_{CLK}$ (f_{CLK} : CPU clock)

15.6 Cautions on Using DMA Controller

(1) Priority of DMA

During DMA transfer, requests for transfer on other DMA channels are held pending even if they are generated. After the DMA transfer in progress is completed, the pending DMA start request is accepted and DMA transfer is started. If two or more DMA start requests are received at the same time, however, the priority order is DMA channel 0 > DMA channel 1 > DMA channel 2 > DMA channel 3.

(2) Interrupt requests and operation in case of contention

During DMA transfer, interrupt requests are held pending even if they are generated. After the DMA transfer in progress is completed, the pending interrupt request is accepted. At this time, an instruction will not be inserted between DMA transfer processing and reception of the interrupt request. If a DMA start request is generated at the time an interrupt request is received, priority is given to the DMA transfer.

(3) DMA response time

The response time of DMA transfer is as follows.

Table 15-3. Response Time of DMA Transfer

	Minimum Time	Maximum Time
Response time	3 clocks	10 clocks ^{Note}

Note The maximum time necessary to execute an instruction from internal RAM is 16 clock cycles.

Cautions 1. The above response time does not include the two clock cycles required for a DMA transfer.

- 2. When executing a DMA pending instruction (see 15.6 (4)), the maximum response time is extended by the execution time of that instruction to be held pending.
- 3. Do not specify successive transfer triggers for a channel within a period equal to the maximum response time plus one clock cycle, because they might be ignored.

Remark 1 clock: $1/f_{CLK}$ (f_{CLK} : CPU clock)

(4) Operation in standby mode

The DMA controller operates as follows in the standby mode.

Table 15-4. DMA Operation in Standby Mode

Status	DMA Operation
HALT mode	Normal operation
STOP mode	Stops operation. If DMA transfer and STOP instruction execution contend, DMA transfer may be damaged. Therefore, stop DMA before executing the STOP instruction.

(5) DMA pending instruction

Even if a DMA request is generated, DMA transfer is held pending immediately after the following instructions.

- CALL !addr16
- CALL \$!addr20
- CALL !!addr20
- CALL rp
- CALLT [addr5]
- BRK
- MOV PSW, #byte
- MOV PSW, A
- MOV1 PSW. bit, CY
- SET1 PSW. bit
- CLR1 PSW. bit
- POP PSW
- BTCLR PSW. bit, \$addr20
- EI
- DI
- Write instructions for registers IF0L, IF0H, IF1L, IF1H, IF2L, IF2H, IF3L, MK0L, MK0H, MK1L, MK1H, MK2L, MK2H, MK3L, PR00L, PR00H, PR01L, PR01H, PR02L, PR02H, PR03L, PR10L, PR10H, PR11L, PR11H, PR12L, PR12H, and PR13L each.
- Instruction for accessing the data flash memory

(6) Operation if address in general-purpose register area or other than those of internal RAM area is specified

The address indicated by DMA RAM address register n (DRAn) is incremented during DMA transfer. If the address is incremented to an address in the general-purpose register area or exceeds the area of the internal RAM, the following operation is performed.

- In mode of transfer from SFR to RAM
The data of that address is lost.
- In mode of transfer from RAM to SFR
Undefined data is transferred to SFR.

In either case, malfunctioning may occur or damage may be done to the system. Therefore, make sure that the address is within the internal RAM area other than the general-purpose register area.

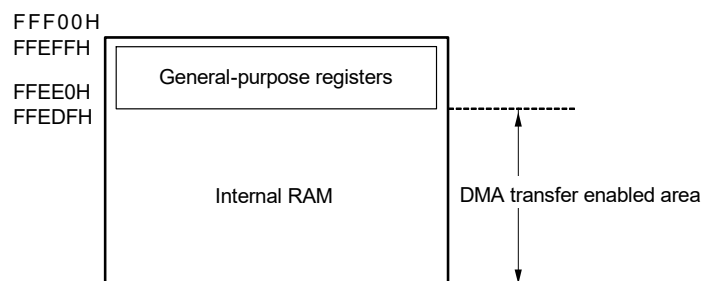

(7) Operation if instructions for accessing the data flash area

If the data flash area is accessed after an next instruction execution from start of DMA transfer, a 3-clock wait will be inserted to the next instruction.

Instruction 1

DMA transfer

Instruction 2 ← The wait of three clock cycles occurs.

MOV A, ! DataFlash area

CHAPTER 16 INTERRUPT FUNCTIONS

The interrupt function switches the program execution to other processing. When the branch processing is finished, the program returns to the interrupted processing.

The number of interrupt sources differs, depending on the product.

		20-pin	24, 25-pin	30, 32, 36-pin	40, 44-pin	48-pin	52-pin	64-pin	80, 100-pin	128-pin
Maskable interrupts	External	3	5	6	7	10	12	13	13	13
	Internal	23	24	27	27	27	27	27	37	41

16.1 Interrupt Function Types

The following two types of interrupt functions are used.

(1) Maskable interrupts

These interrupts undergo mask control. Maskable interrupts can be divided into four priority groups by setting the priority specification flag registers (PR00L, PR00H, PR01L, PR01H, PR02L, PR02H, PR03L, PR10L, PR10H, PR11L, PR11H, PR12L, PR12H, PR13L).

Multiple interrupt servicing can be applied to low-priority interrupts when high-priority interrupts are generated. If two or more interrupt requests, each having the same priority, are simultaneously generated, then they are processed according to the default priority of vectored interrupt servicing. For default priority, see **Table 16-1**.

A standby release signal is generated and STOP, HALT, and SNOOZE modes are released.

External interrupt requests and internal interrupt requests are provided as maskable interrupts.

(2) Software interrupt

This is a vectored interrupt generated by executing the BRK instruction. It is acknowledged even when interrupts are disabled. The software interrupt does not undergo interrupt priority control.

16.2 Interrupt Sources and Configuration

Interrupt sources include maskable interrupts and software interrupts. In addition, they also have up to seven reset sources (see **Table 16-1**). The vector codes that store the program start address when branching due to the generation of a reset or various interrupt requests are two bytes each, so interrupts jump to a 64 K address of 00000H to 0FFFFH.

Table 16-1. Interrupt Source List (1/4)

Interrupt Type	Default Priority ^{Note 1}	Interrupt Source		Internal/ External	Vector Table Address	Basic Configuration Type ^{Note 2}	128-pin	100-pin	80-pin	64-pin	52-pin	48-pin	44-pin	40-pin	36-pin	32-pin	30-pin	25-pin	24-pin	20-pin			
		Name	Trigger																				
Maskable	0	INTWDTI	Watchdog timer interval ^{Note 3} (75% of the overflow time + 1/2 f _{IL})	Internal	00004H	(A)	√	√	√	√	√	√	√	√	√	√	√	√	√	√			
	1	INTLVI	Voltage detection ^{Note 4}		00006H		√	√	√	√	√	√	√	√	√	√	√	√	√	√	√		
	2	INTP0	Pin input edge detection	External	00008H	(B)	√	√	√	√	√	√	√	√	√	√	√	√	√	√	√		
	3	INTP1			0000AH		√	√	√	√	√	√	√	√	√	√	√	√	√	√	√	√	
	4	INTP2			0000CH		√	√	√	√	√	√	√	√	√	√	√	√	√	√	√	√	
	5	INTP3			0000EH		√	√	√	√	√	√	√	√	√	√	√	√	√	√	√	√	
	6	INTP4			00010H		√	√	√	√	√	√	√	√	√	√	√	√	√	√	√	√	
	7	INTP5			00012H		√	√	√	√	√	√	√	√	√	√	√	√	√	√	√	√	√
	8	INTST2/ INTCSI20/ INTIIC20			UART2 transmission transfer end or buffer empty interrupt/CSI20 transfer end or buffer empty interrupt/IIC20 transfer end		Internal	00014H	(A)	√	√	√	√	√	√	√	√	√	√	√	√	√	√
	9	INTSR2/ INTCSI21/ INTIIC21	UART2 reception transfer end/CSI21 transfer end or buffer empty interrupt/IIC21 transfer end	00016H	√	√		√		√	√	√	√	√	√	√	√	√	√	√	√	√	
	10	INTSRE2	UART2 reception communication error occurrence	Internal	00018H	(A)	√	√	√	√	√	√	√	√	√	√	√	√	√	√	√		
		INTTM11H	End of timer channel 11 count or capture (at higher 8-bit timer operation)				√	√	√	√	√	√	√	√	√	√	√	√	√	√	√	√	√
	11	INTDMA0	End of DMA0 transfer	Internal	0001AH	(A)	√	√	√	√	√	√	√	√	√	√	√	√	√	√	√		
	12	INTDMA1	End of DMA1 transfer		0001CH		√	√	√	√	√	√	√	√	√	√	√	√	√	√	√	√	
	13	INTST0/ INTCSI00/ INTIIC00	UART0 transmission transfer end or buffer empty interrupt/CSI00 transfer end or buffer empty interrupt/IIC00 transfer end	Internal	0001EH	(A)	√	√	√	√	√	√	√	√	√	√	√	√	√	√	√		
14	INTSR0/ INTCSI01/ INTIIC01	UART0 reception transfer end/CSI01 transfer end or buffer empty interrupt/IIC01 transfer end	00020H				√	√	√	√	√	√	√	√	√	√	√	√	√	√	√	√	
15	INTSRE0	UART0 reception communication error occurrence	Internal	00022H	(A)	√	√	√	√	√	√	√	√	√	√	√	√	√	√	√			
	INTTM01H	End of timer channel 01 count or capture (at higher 8-bit timer operation)				√	√	√	√	√	√	√	√	√	√	√	√	√	√	√	√	√	

- Notes**
- The default priority determines the sequence of interrupts if two or more maskable interrupts occur simultaneously. Zero indicates the highest priority and 53 indicates the lowest priority.
 - Basic configuration types (A) to (D) correspond to (A) to (D) in Figure 16-1.
 - When bit 7 (WDTINT) of the option byte (000C0H) is set to 1.
 - When bit 7 (LVIMD) of the voltage detection level register (LVIS) is cleared to 0.
 - INTSR2 only.
 - INTSR0 only.

Table 16-1. Interrupt Source List (2/4)

Interrupt Type	Default Priority <small>Note 1</small>	Interrupt Source		Internal/ External	Vector Table Address	Basic Configuration Type <small>Note 2</small>	128-pin	100-pin	80-pin	64-pin	52-pin	48-pin	44-pin	40-pin	36-pin	32-pin	30-pin	25-pin	24-pin	20-pin				
		Name	Trigger																					
Maskable	16	INTST1/ INTCSI10/ INTIIC10	UART1 transmission transfer end or buffer empty interrupt/CSI10 transfer end or buffer empty interrupt/IIC10 transfer end	Internal	00024H	(A)	√	√	√	√	Note 3	Note 3	Note 3	Note 3	Note 3	Note 3	Note 3	Note 3	Note 3	Note 3	Note 3			
	17	INTSR1/ INTCSI11/ INTIIC11	UART1 reception transfer end/CSI11 transfer end or buffer empty interrupt/IIC11 transfer end		00026H		√	√	√	√	√	√	√	√	√	√	√	√	√	√	√	√	√	
	18	INTSRE1	UART1 reception communication error occurrence		00028H		√	√	√	√	√	√	√	√	√	√	√	√	√	√	√	√	√	√
		INTTM03H	End of timer channel 03 count or capture (at higher 8-bit timer operation)				√	√	√	√	√	√	√	√	√	√	√	√	√	√	√	√	√	√
	19	INTIICA0	End of IICA0 communication		0002AH		√	√	√	√	√	√	√	√	√	√	√	√	√	√	√	√	–	–
	20	INTTM00	End of timer channel 00 count or capture		0002CH		√	√	√	√	√	√	√	√	√	√	√	√	√	√	√	√	√	√
	21	INTTM01	End of timer channel 01 count or capture (at 16-bit/lower 8-bit timer operation)		0002EH		√	√	√	√	√	√	√	√	√	√	√	√	√	√	√	√	√	√
	22	INTTM02	End of timer channel 02 count or capture		00030H		√	√	√	√	√	√	√	√	√	√	√	√	√	√	√	√	√	√
	23	INTTM03	End of timer channel 03 count or capture (at 16-bit/lower 8-bit timer operation)		00032H		√	√	√	√	√	√	√	√	√	√	√	√	√	√	√	√	√	√
	24	INTAD	End of A/D conversion		00034H		√	√	√	√	√	√	√	√	√	√	√	√	√	√	√	√	√	√
	25	INTRTC	Fixed-cycle signal of real-time clock/alarm match detection		00036H		√	√	√	√	√	√	√	√	√	√	√	√	√	√	√	√	√	√
	26	INTIT	Interval signal of 12-bit interval timer detection		0038H		√	√	√	√	√	√	√	√	√	√	√	√	√	√	√	√	√	√
	27	INTKR	Key return signal detection		External		0003AH	(A)	√	√	√	√	√	√	√	√	–	–	–	–	–	–	–	–
	28	INTST3/ INTCSI30/ INTIIC30	UART3 transmission transfer end or buffer empty interrupt/CSI30 transfer end or buffer empty interrupt/IIC30 transfer end		Internal		0003CH		√	√	√	–	–	–	–	–	–	–	–	–	–	–	–	–
29	INTSR3/ INTCSI31/ INTIIC31	UART3 reception transfer end/CSI31 transfer end or buffer empty interrupt/IIC31 transfer end	0003EH	√		√	√		–	–	–	–	–	–	–	–	–	–	–	–	–	–	–	
30	INTTM13	End of timer channel 13 count or capture (at 16-bit/lower 8-bit timer operation)	00040H	√		√	√		–	–	–	–	–	–	–	–	–	–	–	–	–	–	–	

- Notes**
- The default priority determines the sequence of interrupts if two or more maskable interrupts occur simultaneously. Zero indicates the highest priority and 53 indicates the lowest priority.
 - Basic configuration types (A) to (D) correspond to (A) to (D) in Figure 16-1.
 - INTST1 only.

Table 16-1. Interrupt Source List (3/4)

Interrupt Type	Default Priority ^{Note 1}	Interrupt Source		Internal/ External	Vector Table Address	Basic Configuration Type ^{Note 2}	Basic Configuration															
		Name	Trigger				128-pin	100-pin	80-pin	64-pin	52-pin	48-pin	44-pin	40-pin	36-pin	32-pin	30-pin	25-pin	24-pin	20-pin		
Maskable	31	INTTM04	End of timer channel 04 count or capture	Internal	00042H	(A)	√	√	√	√	√	√	√	√	√	√	√	√	√	√		
	32	INTTM05	End of timer channel 05 count or capture		00044H		√	√	√	√	√	√	√	√	√	√	√	√	√	√		
	33	INTTM06	End of timer channel 06 count or capture		00046H		√	√	√	√	√	√	√	√	√	√	√	√	√	√	√	
	34	INTTM07	End of timer channel 07 count or capture		00048H		√	√	√	√	√	√	√	√	√	√	√	√	√	√	√	
	35	INTP6	Pin input edge detection	External	0004AH	(B)	√	√	√	√	√	√	-	-	-	-	-	-	-	-		
	36	INTP7			0004CH		√	√	√	√	-	-	-	-	-	-	-	-	-	-	-	
	37	INTP8			0004EH		√	√	√	√	√	√	-	-	-	-	-	-	-	-	-	
	38	INTP9			00050H		√	√	√	√	√	√	-	-	-	-	-	-	-	-	-	
	39	INTP10			00052H		√	√	√	√	√	-	-	-	-	-	-	-	-	-	-	
	40	INTP11			00054H		√	√	√	√	√	-	-	-	-	-	-	-	-	-	-	-
	41	INTTM10	End of timer channel 10 count or capture	Internal	00056H	(A)	√	√	√	-	-	-	-	-	-	-	-	-	-	-		
	42	INTTM11	End of timer channel 11 count or capture (at 16-bit/lower 8-bit timer operation)		00058H		√	√	√	-	-	-	-	-	-	-	-	-	-	-		
	43	INTTM12	End of timer channel 12 count or capture		0005AH		√	√	√	-	-	-	-	-	-	-	-	-	-	-	-	
	44	INTSRE3	UART3 reception communication error occurrence		0005CH		√	√	√	-	-	-	-	-	-	-	-	-	-	-	-	
		INTTM13H	End of timer channel 13 count or capture (at higher 8-bit timer operation)				√	√	√	-	-	-	-	-	-	-	-	-	-	-	-	
	45	INTMD	End of division operation/ Overflow of multiply-accumulation result occurs		0005EH		√	√	√	√	√	√	√	√	√	√	√	√	√	√	√	
	46	INTIICA1	End of IICA1 communication		00060H		√	√	√	-	-	-	-	-	-	-	-	-	-	-	-	
	47	INTFL	Reserved		00062H		√	√	√	√	√	√	√	√	√	√	√	√	√	√	√	
	48	INTDMA2	End of DMA2 transfer		00064H		√	√	√	-	-	-	-	-	-	-	-	-	-	-	-	
	49	INTDMA3	End of DMA3 transfer		00066H		√	√	√	-	-	-	-	-	-	-	-	-	-	-	-	
50	INTTM14	End of timer channel 14 count or capture	00068H		√		-	-	-	-	-	-	-	-	-	-	-	-	-	-		
51	INTTM15	End of timer channel 15 count or capture	0006AH		√		-	-	-	-	-	-	-	-	-	-	-	-	-	-		
52	INTTM16	End of timer channel 16 count or capture	0006CH		√		-	-	-	-	-	-	-	-	-	-	-	-	-	-		
53	INTTM17	End of timer channel 17 count or capture	0006EH	√	-	-	-	-	-	-	-	-	-	-	-	-	-	-				

- Notes**
- The default priority determines the sequence of interrupts if two or more maskable interrupts occur simultaneously. Zero indicates the highest priority and 53 indicates the lowest priority.
 - Basic configuration types (A) to (D) correspond to (A) to (D) in Figure 16-1.

Table 16-1. Interrupt Source List (4/4)

Interrupt Type	Default Priority ^{Note 1}	Interrupt Source		Internal/External	Vector Table Address	Basic Configuration Type ^{Note 2}	128-pin	100-pin	80-pin	64-pin	52-pin	48-pin	44-pin	40-pin	36-pin	32-pin	30-pin	25-pin	24-pin	20-pin							
Software	–	BRK	Execution of BRK instruction	–	0007EH	(D)	√	√	√	√	√	√	√	√	√	√	√	√	√	√	√						
Reset	–	RESET	RESET pin input	–	00000H	–	√	√	√	√	√	√	√	√	√	√	√	√	√	√	√						
		POR	Power-on-reset				√	√	√	√	√	√	√	√	√	√	√	√	√	√	√	√	√	√			
		LVD	Voltage detection ^{Note 3}				√	√	√	√	√	√	√	√	√	√	√	√	√	√	√	√	√	√	√		
		WDT	Overflow of watchdog timer				√	√	√	√	√	√	√	√	√	√	√	√	√	√	√	√	√	√	√		
		TRAP	Execution of illegal instruction ^{Note 4}				√	√	√	√	√	√	√	√	√	√	√	√	√	√	√	√	√	√	√	√	
		IAW	Illegal-memory access				√	√	√	√	√	√	√	√	√	√	√	√	√	√	√	√	√	√	√	√	√
		RPE	RAM parity error				√	√	√	√	√	√	√	√	√	√	√	√	√	√	√	√	√	√	√	√	√

- Notes**
1. The default priority determines the sequence of interrupts if two or more maskable interrupts occur simultaneously. Zero indicates the highest priority and 53 indicates the lowest priority.
 2. Basic configuration types (A) to (D) correspond to (A) to (D) in Figure 16-1.
 3. When bit 7 (LVIMD) of the voltage detection level register (LVIS) is set to 1.
 4. When the instruction code in FFH is executed.
Reset by the illegal instruction execution not issued by emulation with the in-circuit emulator or on-chip debug emulator.

Figure 16-1. Basic Configuration of Interrupt Function (1/2)

(A) Internal maskable interrupt

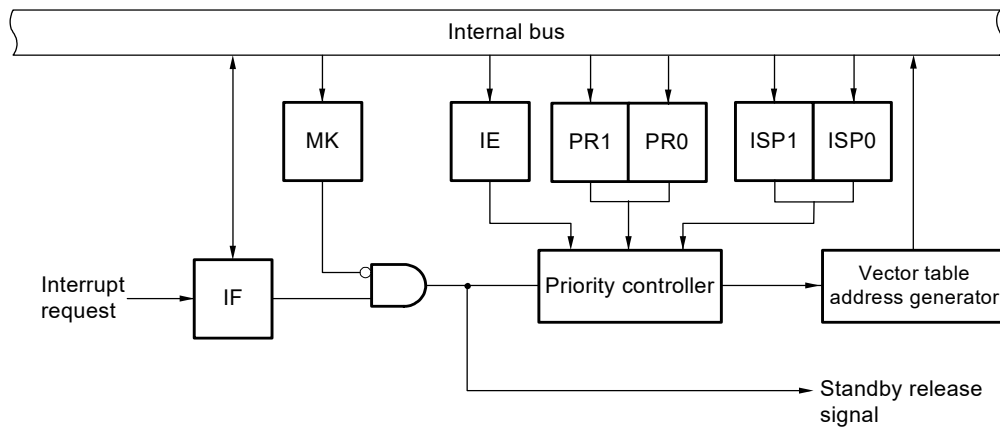

(B) External maskable interrupt (INTPn)

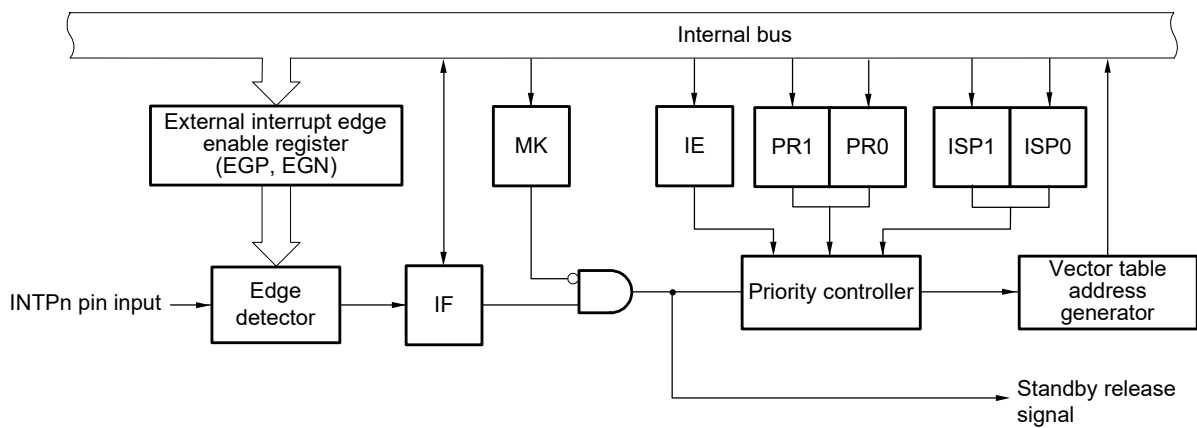

- IF: Interrupt request flag
- IE: Interrupt enable flag
- ISP0: In-service priority flag 0
- ISP1: In-service priority flag 1
- MK: Interrupt mask flag
- PR0: Priority specification flag 0
- PR1: Priority specification flag 1

Remark

20-pin:	n = 0, 3, 5
24, 25-pin:	n = 0, 1, 3 to 5
30, 32, 36, 40, 44-pin:	n = 0 to 5
48-pin:	n = 0 to 6, 8, 9
52-pin:	n = 0 to 6, 8 to 11
64, 80, 100, 128-pin:	n = 0 to 11

Figure 16-1. Basic Configuration of Interrupt Function (2/2)

(C) External maskable interrupt (INTKR)

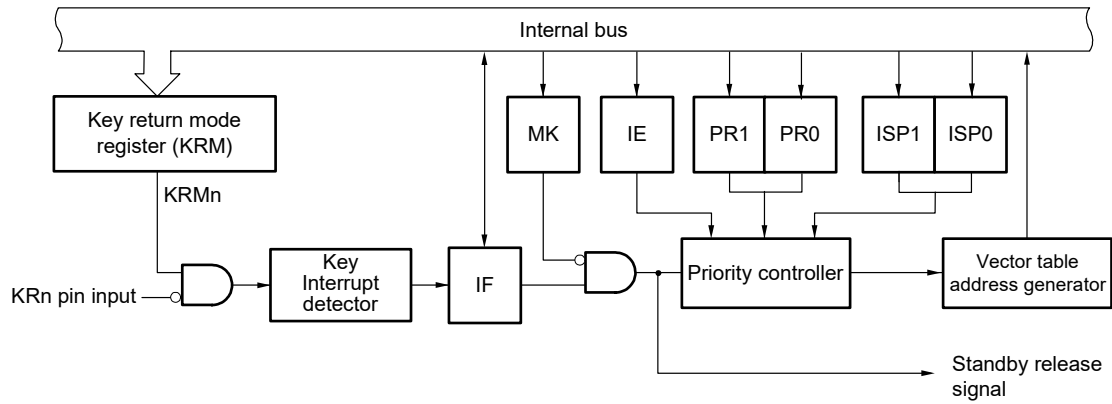

(D) Software interrupt

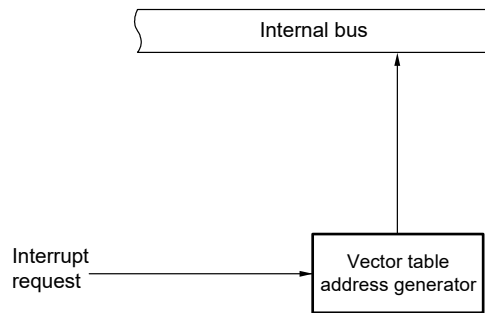

- IF: Interrupt request flag
- IE: Interrupt enable flag
- ISP0: In-service priority flag 0
- ISP1: In-service priority flag 1
- MK: Interrupt mask flag
- PR0: Priority specification flag 0
- PR1: Priority specification flag 1

Remark 40, 44-pin: n = 0 to 4
 48-pin: n = 0 to 5
 52, 64, 80, 100, 128-pin: n = 0 to 7

16.3 Registers Controlling Interrupt Functions

The following 6 types of registers are used to control the interrupt functions.

- Interrupt request flag registers (IF0L, IF0H, IF1L, IF1H, IF2L, IF2H, IF3L)
- Interrupt mask flag registers (MK0L, MK0H, MK1L, MK1H, MK2L, MK2H, MK3L)
- Priority specification flag registers (PR00L, PR00H, PR01L, PR01H, PR02L, PR02H, PR03L, PR03H, PR10L, PR10H, PR11L, PR11H, PR12L, PR12H, PR13L)
- External interrupt rising edge enable registers (EGP0, EGP1)
- External interrupt falling edge enable registers (EGN0, EGN1)
- Program status word (PSW)

Table 16-2 shows a list of interrupt request flags, interrupt mask flags, and priority specification flags corresponding to interrupt request sources.

Table 16-2. Flags Corresponding to Interrupt Request Sources (1/4)

Interrupt Source	Interrupt Request Flag		Interrupt Mask Flag		Priority Specification Flag			128-pin	100-pin	80-pin	64-pin	52-pin	48-pin	44-pin	40-pin	36-pin	32-pin	30-pin	25-pin	24-pin	20-pin			
	Register	Register	Register	Register	Register	Register	Register																	
INTWDTI	WDTIIF	IF0L	WDTIMK	MK0L	WDTIPR0, WDTIPR1	PR00L, PR10L	√	√	√	√	√	√	√	√	√	√	√	√	√	√	√			
INTLVI	LVIIIF		LVIMK		LVIPR0, LVIPR1		√	√	√	√	√	√	√	√	√	√	√	√	√	√	√	√	√	
INTP0	PIF0		PMK0		PPR00, PPR10		√	√	√	√	√	√	√	√	√	√	√	√	√	√	√	√	√	
INTP1	PIF1		PMK1		PPR01, PPR11		√	√	√	√	√	√	√	√	√	√	√	√	√	√	√	√	√	—
INTP2	PIF2		PMK2		PPR02, PPR12		√	√	√	√	√	√	√	√	√	√	√	√	√	√	—	—	—	—
INTP3	PIF3		PMK3		PPR03, PPR13		√	√	√	√	√	√	√	√	√	√	√	√	√	√	√	√	√	√
INTP4	PIF4		PMK4		PPR04, PPR14		√	√	√	√	√	√	√	√	√	√	√	√	√	√	√	√	√	—
INTP5	PIF5		PMK5		PPR05, PPR15		√	√	√	√	√	√	√	√	√	√	√	√	√	√	√	√	√	√

Table 16-2. Flags Corresponding to Interrupt Request Sources (2/4)

Interrupt Source	Interrupt Request Flag		Interrupt Mask Flag		Priority Specification Flag		128-pin	100-pin	80-pin	64-pin	52-pin	48-pin	44-pin	40-pin	36-pin	32-pin	30-pin	25-pin	24-pin	20-pin			
	Register	Register	Register	Register	Register	Register																	
INTST2 ^{Note 1}	STIF2 ^{Note 1}	IF0H	STMK2 ^{Note 1}	MK0H	STPR02, STPR12 ^{Note 1}	PR00H, PR10H	√	√	√	√	√	√	√	√	√	√	√	—	—	—			
INTCSI20 ^{Note 1}	CSIIF20 ^{Note 1}		CSIMK20 ^{Note 1}		CSIPR020, CSIPR120 ^{Note 1}		√	√	√	√	√	√	√	√	√	√	√	√	√	—	—	—	
INTIIC20 ^{Note 1}	IICIF20 ^{Note 1}		IICMK20 ^{Note 1}		IICPR020, IICPR120 ^{Note 1}		√	√	√	√	√	√	√	√	√	√	√	√	√	—	—	—	
INTSR2 ^{Note 2}	SRIF2 ^{Note 2}		SRMK2 ^{Note 2}		SRPR02, SRPR12 ^{Note 2}		√	√	√	√	√	√	√	√	√	√	√	√	√	—	—	—	
INTCSI21 ^{Note 2}	CSIIF21 ^{Note 2}		CSIMK21 ^{Note 2}		CSIPR021, CSIPR121 ^{Note 2}		√	√	√	√	√	√	√	√	√	√	√	√	—	—	—	—	
INTIIC21 ^{Note 2}	IICIF21 ^{Note 2}		IICMK21 ^{Note 2}		IICPR021, IICPR121 ^{Note 2}		√	√	√	√	√	√	√	√	√	√	√	√	—	—	—	—	
INTSRE2 ^{Note 3}	SREIF2 ^{Note 3}		SREMK2 ^{Note 3}		SREPR02, SREPR12 ^{Note 3}		√	√	√	√	√	√	√	√	√	√	√	√	√	—	—	—	
INTTM11H ^{Note 3}	TMIF11H ^{Note 3}		TMMK11H ^{Note 3}		TMPR011H, TMPR111H ^{Note 3}		√	√	√	—	—	—	—	—	—	—	—	—	—	—	—	—	
INTDMA0	DMAIF0		DMAMK0		DMAPR00, DMAPR10		√	√	√	√	√	√	√	√	√	√	√	√	√	√	√	√	√
INTDMA1	DMAIF1		DMAMK1		DMAPR01, DMAPR11		√	√	√	√	√	√	√	√	√	√	√	√	√	√	√	√	√
INTST0 ^{Note 4}	STIF0 ^{Note 4}		STMK0 ^{Note 4}		STPR00, STPR10 ^{Note 4}		√	√	√	√	√	√	√	√	√	√	√	√	√	√	√	√	√
INTCSI00 ^{Note 4}	CSIIF00 ^{Note 4}		CSIMK00 ^{Note 4}		CSIPR000, CSIPR100 ^{Note 4}		√	√	√	√	√	√	√	√	√	√	√	√	√	√	√	√	√
INTIIC00 ^{Note 4}	IICIF00 ^{Note 4}		IICMK00 ^{Note 4}		IICPR000, IICPR100 ^{Note 4}		√	√	√	√	√	√	√	√	√	√	√	√	√	√	√	√	√
INTSR0 ^{Note 5}	SRIF0 ^{Note 5}		SRMK0 ^{Note 5}		SRPR00, SRPR10 ^{Note 5}		√	√	√	√	√	√	√	√	√	√	√	√	√	√	√	√	√
INTCSI01 ^{Note 5}	CSIIF01 ^{Note 5}	CSIMK01 ^{Note 5}	CSIPR001, CSIPR101 ^{Note 5}	√	√	√	√	√	√	—	—	—	—	—	—	—	—	—	—	—			
INTIIC01 ^{Note 5}	IICIF01 ^{Note 5}	IICMK01 ^{Note 5}	IICPR001, IICPR101 ^{Note 5}	√	√	√	√	√	√	—	—	—	—	—	—	—	—	—	—	—			
INTSRE0 ^{Note 6}	SREIF0 ^{Note 6}	SREMK0 ^{Note 6}	SREPR00, SREPR10 ^{Note 6}	√	√	√	√	√	√	√	√	√	√	√	√	√	√	√	√	√			
INTTM01H ^{Note 6}	TMIF01H ^{Note 6}	TMMK01H ^{Note 6}	TMPR001H, TMPR101H ^{Note 6}	√	√	√	√	√	√	√	√	√	√	√	√	√	√	√	√	√			

- Notes**
1. If one of the interrupt sources INTST2, INTCSI20, and INTIIC20 is generated, bit 0 of the IF0H register is set to 1. Bit 0 of the MK0H, PR00H, and PR10H registers supports these three interrupt sources.
 2. If one of the interrupt sources INTSR2, INTCSI21, and INTIIC21 is generated, bit 1 of the IF0H register is set to 1. Bit 1 of the MK0H, PR00H, and PR10H registers supports these three interrupt sources.
 3. Do not use a UART2 reception error interrupt and an interrupt of channel 1 of TAU1 (at higher 8-bit timer operation) at the same time because they share flags for the interrupt request sources. If the UART2 reception error interrupt is not used (EOC01 = 0), UART2 and channel 1 of TAU1 (at higher 8-bit timer operation) can be used at the same time. If one of the interrupt sources INTSRE2 and INTTM11H is generated, bit 2 of the IF0H register is set to 1. Bit 2 of the MK0H, PR00H, and PR10H registers supports these two interrupt sources.
 4. If one of the interrupt sources INTST3, INTCSI30, and INTIIC30 is generated, bit 4 of the IF1H register is set to 1. Bit 4 of the MK1H, PR01H, and PR11H registers supports these three interrupt sources.
 5. If one of the interrupt sources INTSR0, INTCSI01, and INTIIC01 is generated, bit 6 of the IF0H register is set to 1. Bit 6 of the MK0H, PR00H, and PR10H registers supports these three interrupt sources.
 6. Do not use a UART0 reception error interrupt and an interrupt of channel 1 of TAU0 (at higher 8-bit timer operation) at the same time because they share flags for the interrupt request sources. If the UART0 reception error interrupt is not used (EOC01 = 0), UART0 and channel 1 of TAU0 (at higher 8-bit timer operation) can be used at the same time. If one of the interrupt sources INTSRE0 and INTTM01H is generated, bit 7 of the IF0H register is set to 1. Bit 7 of the MK0H, PR00H, and PR10H registers supports these two interrupt sources.

Table 16-2. Flags Corresponding to Interrupt Request Sources (3/4)

Interrupt Source	Interrupt Request Flag		Interrupt Mask Flag		Priority Specification Flag		128-pin	100-pin	80-pin	64-pin	52-pin	48-pin	44-pin	40-pin	36-pin	32-pin	30-pin	25-pin	24-pin	20-pin				
		Register		Register		Register																		
INTST1 ^{Note 1}	STIF1 ^{Note 1}	IF1L	STMK1 ^{Note 1}	MK1L	STPR01, STPR11 ^{Note 1}	PR01L, PR11L	√	√	√	√	√	√	√	√	√	√	√	√	√	√	√			
INTCSI10 ^{Note 1}	CSIF10 ^{Note 1}		CSIMK10 ^{Note 1}		CSIPR010, CSIPR110 ^{Note 1}		√	√	√	√	–	–	–	–	–	–	–	–	–	–	–	–	–	
INTIIC10 ^{Note 1}	IICIF10 ^{Note 1}		IICMK10 ^{Note 1}		IICPR010, IICPR110 ^{Note 1}		√	√	√	√	–	–	–	–	–	–	–	–	–	–	–	–	–	
INTSR1 ^{Note 2}	SRIF1 ^{Note 2}		SRMK1 ^{Note 2}		SRPR01, SRPR11 ^{Note 2}		√	√	√	√	√	√	√	√	√	√	√	√	√	√	√	√	√	√
INTCSI11 ^{Note 2}	CSIF11 ^{Note 2}		CSIMK11 ^{Note 2}		CSIPR011, CSIPR111 ^{Note 2}		√	√	√	√	√	√	√	√	√	√	√	√	√	√	√	√	√	√
INTIIC11 ^{Note 2}	IICIF11 ^{Note 2}		IICMK11 ^{Note 2}		IICPR011, IICPR111 ^{Note 2}		√	√	√	√	√	√	√	√	√	√	√	√	√	√	√	√	√	√
INTSRE1 ^{Note 3}	SREIF1 ^{Note 3}		SREMK1 ^{Note 3}		SREPR01, SREPR11 ^{Note 3}		√	√	√	√	√	√	√	√	√	√	√	√	√	√	√	√	√	√
INTTM03H ^{Note 3}	TMIF03H ^{Note 3}	TMMK03H ^{Note 3}	TMPR003H, TMPR103H ^{Note 3}	√	√	√	√	√	√	√	√	√	√	√	√	√	√	√	√	√	√			
INTIICA0	IICAIF0	IICAMK0	IICAPR00, IICAPR10	√	√	√	√	√	√	√	√	√	√	√	√	√	√	√	√	√	–			
INTTM00	TMIF00	TMMK00	TMPR000, TMPR100	√	√	√	√	√	√	√	√	√	√	√	√	√	√	√	√	√	√			
INTTM01	TMIF01	TMMK01	TMPR001, TMPR101	√	√	√	√	√	√	√	√	√	√	√	√	√	√	√	√	√	√			
INTTM02	TMIF02	TMMK02	TMPR002, TMPR102	√	√	√	√	√	√	√	√	√	√	√	√	√	√	√	√	√	√			
INTTM03	TMIF03	TMMK03	TMPR003, TMPR103	√	√	√	√	√	√	√	√	√	√	√	√	√	√	√	√	√	√			
INTAD	ADIF	IF1H	ADMK	MK1H	ADPR0, ADPR1	PR01H, PR11H	√	√	√	√	√	√	√	√	√	√	√	√	√	√	√			
INTRTC	RTCIF		RTCMK		RT CPR0, RT CPR1		√	√	√	√	√	√	√	√	√	√	√	√	√	√	√	√	√	
INTIT	ITIF		ITMK		ITPR0, ITPR1		√	√	√	√	√	√	√	√	√	√	√	√	√	√	√	√	√	
INTKR	KRIF		KRMK		KRPR0, KRPR1		√	√	√	√	√	√	√	√	√	√	–	–	–	–	–	–	–	–
INTST3 ^{Note 4}	STIF3 ^{Note 4}		STMK3 ^{Note 4}		STPR03, STPR13 ^{Note 4}		√	√	√	–	–	–	–	–	–	–	–	–	–	–	–	–	–	–
INTCSI30 ^{Note 4}	CSIF30 ^{Note 4}		CSIMK30 ^{Note 4}		CSIPR030, CSIPR130 ^{Note 4}		√	√	√	–	–	–	–	–	–	–	–	–	–	–	–	–	–	–
INTIIC30 ^{Note 4}	IICIF30 ^{Note 4}		IICMK30 ^{Note 4}		IICPR030, IICPR130 ^{Note 4}		√	√	√	–	–	–	–	–	–	–	–	–	–	–	–	–	–	–
INTSR3 ^{Note 5}	SRIF3 ^{Note 5}	SRMK3 ^{Note 5}	SRPR03, SRPR13 ^{Note 5}	√	√	√	–	–	–	–	–	–	–	–	–	–	–	–	–	–	–			
INTCSI31 ^{Note 5}	CSIF31 ^{Note 5}	CSIMK31 ^{Note 5}	CSIPR031, CSIPR131 ^{Note 5}	√	√	√	–	–	–	–	–	–	–	–	–	–	–	–	–	–	–			
INTIIC31 ^{Note 5}	IICIF31 ^{Note 5}	IICMK31 ^{Note 5}	IICPR031, IICPR131 ^{Note 5}	√	√	√	–	–	–	–	–	–	–	–	–	–	–	–	–	–	–			
INTTM13	TMIF13	TMMK13	TMPR013, TMPR113	√	√	√	–	–	–	–	–	–	–	–	–	–	–	–	–	–	–			
INTTM04	TMIF04	TMMK04	TMPR004, TMPR104	√	√	√	√	√	√	√	√	√	√	√	√	√	√	√	√	√	√			

- Notes**
1. If one of the interrupt sources INTST1, INTCSI10, and INTIIC10 is generated, bit 0 of the IF1L register is set to 1. Bit 0 of the MK1L, PR01L, and PR11L registers supports these three interrupt sources.
 2. If one of the interrupt sources INTSR1, INTCSI11, and INTIIC11 is generated, bit 1 of the IF1L register is set to 1. Bit 1 of the MK1L, PR01L, and PR11L registers supports these three interrupt sources.
 3. Do not use a UART1 reception error interrupt and an interrupt of channel 3 of TAU0 (at higher 8-bit timer operation) at the same time because they share flags for the interrupt request sources. If the UART1 reception error interrupt is not used (EOC03 = 0), UART1 and channel 3 of TAU0 (at higher 8-bit timer operation) can be used at the same time. If one of the interrupt sources INTSRE1 and INTTM03H is generated, bit 2 of the IF1L register is set to 1. Bit 2 of the MK1L, PR01L, and PR11L registers supports these two interrupt sources.
 4. If one of the interrupt sources INTST3, INTCSI30, and INTIIC30 is generated, bit 4 of the IF1H register is set to 1. Bit 4 of the MK1H, PR01H, and PR11H registers supports these three interrupt sources.
 5. If one of the interrupt sources INTSR3, INTCSI31, and INTIIC31 is generated, bit 5 of the IF1H register is set to 1. Bit 5 of the MK1H, PR01H, and PR11H registers supports these three interrupt sources.

Table 16-2. Flags Corresponding to Interrupt Request Sources (4/4)

Interrupt Source	Interrupt Request Flag		Interrupt Mask Flag		Priority Specification Flag		128-pin	100-pin	80-pin	64-pin	52-pin	48-pin	44-pin	40-pin	36-pin	32-pin	30-pin	25-pin	24-pin	20-pin			
		Register		Register		Register																	
INTTM05	TMIF05	IF2L	TMMK05	MK2L	TMPR005, TMPR105	PR02L, PR12L	√	√	√	√	√	√	√	√	√	√	√	√	√	√			
INTTM06	TMIF06		TMMK06		TMPR006, TMPR106		√	√	√	√	√	√	√	√	√	√	√	√	√	√	√	√	
INTTM07	TMIF07		TMMK07		TMPR007, TMPR107		√	√	√	√	√	√	√	√	√	√	√	√	√	√	√	√	√
INTP6	PIF6		PMK6		PPR06, PPR16		√	√	√	√	√	√	√	√	–	–	–	–	–	–	–	–	–
INTP7	PIF7		PMK7		PPR07, PPR17		√	√	√	√	–	–	–	–	–	–	–	–	–	–	–	–	–
INTP8	PIF8		PMK8		PPR08, PPR18		√	√	√	√	√	√	√	√	–	–	–	–	–	–	–	–	–
INTP9	PIF9		PMK9		PPR09, PPR19		√	√	√	√	√	√	√	√	–	–	–	–	–	–	–	–	–
INTP10	PIF10		PMK10		PPR010, PPR110		√	√	√	√	√	√	√	√	–	–	–	–	–	–	–	–	–
INTP11	PIF11		IF2H		PMK11		MK2H	PPR011, PPR111	PR02H, PR12H	√	√	√	√	√	√	–	–	–	–	–	–	–	–
INTTM10	TMIF10				TMMK10			TMPR010, TMPR110		√	√	√	–	–	–	–	–	–	–	–	–	–	–
INTTM11	TMIF11	TMMK11		TMPR011, TMPR111	√	√		√		–	–	–	–	–	–	–	–	–	–	–	–	–	
INTTM12	TMIF12	TMMK12		TMPR012, TMPR112	√	√		√		–	–	–	–	–	–	–	–	–	–	–	–	–	
INTSRE3 ^{Note}	SREIF3 ^{Note}	SREMK3 ^{Note}		SREPR03, SREPR13 ^{Note}	√	√		√		–	–	–	–	–	–	–	–	–	–	–	–	–	
INTTM13H ^{Note}	TMIF13H ^{Note}	TMMK13H ^{Note}		TMPR013H, TMPR113H ^{Note}	√	√		√		–	–	–	–	–	–	–	–	–	–	–	–	–	
INTMD	MDIF	MDMK		MDPR0, MDPR1	√	√		√		√	√	√	√	√	√	√	√	√	√	√	√	√	√
INTIICA1	IICAIF1	IICAMK1		IICAPR01, IICAPR11	√	√		√		–	–	–	–	–	–	–	–	–	–	–	–	–	–
INTFL	FLIF	FLMK		FLPR0, FLPR1	√	√		√		√	√	√	√	√	√	√	√	√	√	√	√	√	√
INTDMA2	DMAIF2	IF3L		DMAMK2	MK3L	DMAPR02, DMAPR12		PR03L, PR13L		√	√	√	–	–	–	–	–	–	–	–	–	–	–
INTDMA3	DMAIF3		DMAMK3	DMAPR03, DMAPR13		√	√		√	–	–	–	–	–	–	–	–	–	–	–	–	–	
INTTM14	TMIF14		TMMK14	TMPR014, TMPR114		√	–		–	–	–	–	–	–	–	–	–	–	–	–	–	–	
INTTM15	TMIF15		TMMK15	TMPR015, TMPR115		√	–		–	–	–	–	–	–	–	–	–	–	–	–	–	–	–
INTTM16	TMIF16		TMMK16	TMPR016, TMPR116		√	–		–	–	–	–	–	–	–	–	–	–	–	–	–	–	–
INTTM17	TMIF17		TMMK17	TMPR017, TMPR117		√	–		–	–	–	–	–	–	–	–	–	–	–	–	–	–	–

Note Do not use a UART3 reception error interrupt and an interrupt of channel 3 of TAU1 (at higher 8-bit timer operation) at the same time because they share flags for the interrupt request sources. If the UART3 reception error interrupt is not used (EOC03 = 0), UART3 and channel 3 of TAU1 (at higher 8-bit timer operation) can be used at the same time. If one of the interrupt sources INTSRE3 and INTTM13H is generated, bit 4 of the IF2H register is set to 1. Bit 4 of the MK2H, PR02H, and PR12H registers supports these two interrupt sources.

16.3.1 Interrupt request flag registers (IF0L, IF0H, IF1L, IF1H, IF2L, IF2H, IF3L)

The interrupt request flags are set to 1 when the corresponding interrupt request is generated or an instruction is executed. They are cleared to 0 when an instruction is executed upon acknowledgment of an interrupt request or upon reset signal generation.

When an interrupt is acknowledged, the interrupt request flag is automatically cleared and then the interrupt routine is entered.

The IF0L, IF0H, IF1L, IF1H, IF2L, IF2H, and IF3L registers can be set by a 1-bit or 8-bit memory manipulation instruction. When the IF0L and IF0H registers, the IF1L and IF1H registers, and the IF2L and IF2H registers are combined to form 16-bit registers IF0, IF1, and IF2, they can be set by a 16-bit memory manipulation instruction.

Reset signal generation clears these registers to 00H.

Remark If an instruction that writes data to this register is executed, the number of instruction execution clocks increases by 2 clocks.

Figure 16-2. Format of Interrupt Request Flag Registers (IF0L, IF0H, IF1L, IF1H, IF2L, IF2H, IF3L) (1/2)

Address: FFFE0H After reset: 00H R/W

Symbol	<7>	<6>	<5>	<4>	<3>	<2>	<1>	<0>
IF0L	PIF5	PIF4	PIF3	PIF2	PIF1	PIF0	LVIIIF	WDTIIF

Address: FFFE1H After reset: 00H R/W

Symbol	<7>	<6>	<5>	<4>	<3>	<2>	<1>	<0>
IF0H	SREIF0 TMIF01H	SRIF0 CSIIIF01 IICIF01	STIF0 CSIIIF00 IICIF00	DMAIF1	DMAIF0	SREIF2 TMIF11H	SRIF2 CSIIIF21 IICIF21	STIF2 CSIIIF20 IICIF20

Address: FFFE2H After reset: 00H R/W

Symbol	<7>	<6>	<5>	<4>	<3>	<2>	<1>	<0>
IF1L	TMIF03	TMIF02	TMIF01	TMIF00	IICAIF0	SREIF1 TMIF03H	SRIF1 CSIIIF11 IICIF11	STIF1 CSIIIF10 IICIF10

Address: FFFE3H After reset: 00H R/W

Symbol	<7>	<6>	<5>	<4>	<3>	<2>	<1>	<0>
IF1H	TMIF04	TMIF13	SRIF3 CSIIIF31 IICIF31	STIF3 CSIIIF30 IICIF30	KRIF	ITIF	RTCIF	ADIF

Address: FFFD0H After reset: 00H R/W

Symbol	<7>	<6>	<5>	<4>	<3>	<2>	<1>	<0>
IF2L	PIF10	PIF9	PIF8	PIF7	PIF6	TMIF07	TMIF06	TMIF05

Figure 16-2. Format of Interrupt Request Flag Registers (IF0L, IF0H, IF1L, IF1H, IF2L, IF2H, IF3L) (2/2)

Address: FFFD1H After reset: 00H R/W

Symbol	<7>	<6>	<5>	<4>	<3>	<2>	<1>	<0>
IF2H	FLIF	IICAIF1	MDIF	SREIF3 TMIF13H	TMIF12	TMIF11	TMIF10	PIF11

Address: FFFD2H After reset: 00H R/W

Symbol	7	6	<5>	<4>	<3>	<2>	<1>	<0>
IF3L	0	0	TMIF17	TMIF16	TMIF15	TMIF14	DMAIF3	DMAIF2

XXIFX	Interrupt request flag
0	No interrupt request signal is generated
1	Interrupt request is generated, interrupt request status

- Cautions**
1. The available registers and bits differ depending on the product. For details about the registers and bits available for each product, see Table 16-2. Be sure to set bits that are not available to the initial value.
 2. When manipulating a flag of the interrupt request flag register, use a 1-bit memory manipulation instruction (CLR1). When describing in C language, use a bit manipulation instruction such as “IF0L.0 = 0;” or “_asm(“clr1 IF0L.0”);” because the compiled assembler must be a 1-bit memory manipulation instruction (CLR1).

If a program is described in C language using an 8-bit memory manipulation instruction such as “IF0L &= 0xfe;” and compiled, it becomes the assembler of three instructions.

```
mov a, IF0L
and a, #0FEH
mov IF0L, a
```

In this case, even if the request flag of the another bit of the same interrupt request flag register (IF0L) is set to 1 at the timing between “mov a, IF0L” and “mov IF0L, a”, the flag is cleared to 0 at “mov IF0L, a”. Therefore, care must be exercised when using an 8-bit memory manipulation instruction in C language.

16.3.2 Interrupt mask flag registers (MK0L, MK0H, MK1L, MK1H, MK2L, MK2H, MK3L)

The interrupt mask flags are used to enable/disable the corresponding maskable interrupt.

The MK0L, MK0H, MK1L, MK1H, MK2L, MK2H, and MK3L registers can be set by a 1-bit or 8-bit memory manipulation instruction. When the MK0L and MK0H registers, the MK1L and MK1H registers, and the MK2L and MK2H registers are combined to form 16-bit registers MK0, MK1, and MK2, they can be set by a 16-bit memory manipulation instruction.

Reset signal generation sets these registers to FFH.

Remark If an instruction that writes data to this register is executed, the number of instruction execution clocks increases by 2 clocks.

Figure 16-3. Format of Interrupt Mask Flag Registers (MK0L, MK0H, MK1L, MK1H, MK2L, MK2H, MK3L)

Address: FFFE4H After reset: FFH R/W

Symbol	<7>	<6>	<5>	<4>	<3>	<2>	<1>	<0>
MK0L	PMK5	PMK4	PMK3	PMK2	PMK1	PMK0	LVIMK	WDTIMK

Address: FFFE5H After reset: FFH R/W

Symbol	<7>	<6>	<5>	<4>	<3>	<2>	<1>	<0>
MK0H	SREMK0 TMMK01H	SRMK0 CSIMK01 IICMK01	STMK0 CSIMK00 IICMK00	DMAMK1	DMAMK0	SREMK2 TMMK11H	SRMK2 CSIMK21 IICMK21	STMK2 CSIMK20 IICMK20

Address: FFFE6H After reset: FFH R/W

Symbol	<7>	<6>	<5>	<4>	<3>	<2>	<1>	<0>
MK1L	TMMK03	TMMK02	TMMK01	TMMK00	IICAMK0	SREMK1 TMMK03H	SRMK1 CSIMK11 IICMK11	STMK1 CSIMK10 IICMK10

Address: FFFE7H After reset: FFH R/W

Symbol	<7>	6	5	4	<3>	<2>	<1>	<0>
MK1H	TMMK04	TMMK13	SRMK3 CSIMK31 IICMK31	STMK3 CSIMK30 IICMK30	KRMK	ITMK	RTCMK	ADMK

Address: FFFD4H After reset: FFH R/W

Symbol	<7>	<6>	<5>	<4>	<3>	<2>	<1>	<0>
MK2L	PMK10	PMK9	PMK8	PMK7	PMK6	TMMK07	TMMK06	TMMK05

Address: FFFD5H After reset: FFH R/W

Symbol	<7>	<6>	<5>	<4>	<3>	<2>	<1>	<0>
MK2H	FLMK	IICAMK1	MDMK	SREMK3 TMMK13H	TMMK12	TMMK11	TMMK10	PMK11

Address: FFFD6H After reset: FFH R/W

Symbol	7	6	<5>	<4>	<3>	<2>	<1>	<0>
MK3L	1	1	TMMK17	TMMK16	TMMK15	TMMK14	DMAMK3	DMAMK2

XXMKX	Interrupt servicing control
0	Interrupt servicing enabled
1	Interrupt servicing disabled

Caution The available registers and bits differ depending on the product. For details about the registers and bits available for each product, see Table 16-2. Be sure to set bits that are not available to the initial value.

16.3.3 Priority specification flag registers (PR00L, PR00H, PR01L, PR01H, PR02L, PR02H, PR03L, PR10L, PR10H, PR11L, PR11H, PR12L, PR12H, PR13L)

The priority specification flag registers are used to set the corresponding maskable interrupt priority level.

A priority level is set by using the PR0xy and PR1xy registers in combination (xy = 0L, 0H, 1L, 1H, 2L, 2H, or 3L).

The PR00L, PR00H, PR01L, PR01H, PR02L, PR02H, PR03L, PR10L, PR10H, PR11L, PR11H, PR12L, PR12H, and the PR13L registers can be set by a 1-bit or 8-bit memory manipulation instruction. If the PR00L and PR00H registers, the PR01L and PR01H registers, the PR02L and PR02H registers, the PR10L and PR10H registers, the PR11L and PR11H registers, and the PR12L and PR12H registers are combined to form 16-bit registers PR00, PR01, PR02, PR10, PR11, and PR12, they can be set by a 16-bit memory manipulation instruction.

Reset signal generation sets these registers to FFH.

Remark If an instruction that writes data to this register is executed, the number of instruction execution clocks increases by 2 clocks.

Figure 16-4. Format of Priority Specification Flag Registers (PR00L, PR00H, PR01L, PR01H, PR02L, PR02H, PR03L, PR10L, PR10H, PR11L, PR11H, PR12L, PR12H, PR13L) (1/3)

Address: FFFE8H After reset: FFH R/W

Symbol	<7>	<6>	<5>	<4>	<3>	<2>	<1>	<0>
PR00L	PPR05	PPR04	PPR03	PPR02	PPR01	PPR00	LVIPR0	WDTIPR0

Address: FFFECH After reset: FFH R/W

Symbol	<7>	<6>	<5>	<4>	<3>	<2>	<1>	<0>
PR10L	PPR15	PPR14	PPR13	PPR12	PPR11	PPR10	LVIPR1	WDTIPR1

Address: FFFE9H After reset: FFH R/W

Symbol	<7>	<6>	<5>	<4>	<3>	<2>	<1>	<0>
PR00H	SREPR00 TMPR001H	SRPR00 CSIPR001 IICPR001	STPR00 CSIPR000 IICPR000	DMAPR01	DMAPR00	SREPR02 TMPR011H	SRPR02 CSIPR021 IICPR021	STPR02 CSIPR020 IICPR020

Address: FFFEDH After reset: FFH R/W

Symbol	<7>	<6>	<5>	<4>	<3>	<2>	<1>	<0>
PR10H	SREPR10 TMPR101H	SRPR10 CSIPR101 IICPR101	STPR10 CSIPR100 IICPR100	DMAPR11	DMAPR10	SREPR12 TMPR111H	SRPR12 CSIPR121 IICPR121	STPR12 CSIPR120 IICPR120

Address: FFFEAH After reset: FFH R/W

Symbol	<7>	<6>	<5>	<4>	<3>	<2>	<1>	<0>
PR01L	TMPR003	TMPR002	TMPR001	TMPR000	IICAPR00	SREPR01 TMPR003H	SRPR01 CSIPR011 IICPR011	STPR01 CSIPR010 IICPR010

Address: FFFEEH After reset: FFH R/W

Symbol	<7>	<6>	<5>	<4>	<3>	<2>	<1>	<0>
PR11L	TMPR103	TMPR102	TMPR101	TMPR100	IICAPR10	SREPR11 TMPR103H	SRPR11 CSIPR111 IICPR111	STPR11 CSIPR110 IICPR110

Figure 16-4. Format of Priority Specification Flag Registers (PR00L, PR00H, PR01L, PR01H, PR02L, PR02H, PR03L, PR10L, PR10H, PR11L, PR11H, PR12L, PR12H, PR13L) (2/3)

Address: FFFEBH After reset: FFH R/W

Symbol	<7>	<6>	<5>	<4>	<3>	<2>	<1>	<0>
PR01H	TMPR004	TMPR013	SRPR03 CSIPR031 IICPR031	STPR03 CSIPR030 IICPR030	KRPR0	ITPR0	RTCPR0	ADPR0

Address: FFFEFH After reset: FFH R/W

Symbol	<7>	<6>	<5>	<4>	<3>	<2>	<1>	<0>
PR11H	TMPR104	TMPR113	SRPR13 CSIPR131 IICPR131	STPR13 CSIPR130 IICPR130	KRPR1	ITPR1	RTCPR1	ADPR1

Address: FFFD8H After reset: FFH R/W

Symbol	<7>	<6>	<5>	<4>	<3>	<2>	<1>	<0>
PR02L	PPR010	PPR09	PPR08	PPR07	PPR06	TMPR007	TMPR006	TMPR005

Address: FFFDCH After reset: FFH R/W

Symbol	<7>	<6>	<5>	<4>	<3>	<2>	<1>	<0>
PR12L	PPR110	PPR19	PPR18	PPR17	PPR16	TMPR107	TMPR106	TMPR105

Address: FFFD9H After reset: FFH R/W

Symbol	<7>	6	<5>	4	3	2	1	<0>
PR02H	FLPR0	IICAPR01	MDPR0	SREPR03 TMPR013H	TMPR012	TMPR011	TMPR010	PPR011

Address: FFFDDH After reset: FFH R/W

Symbol	<7>	6	<5>	4	3	2	1	<0>
PR12H	FLPR1	IICAPR11	MDPR1	SREPR13 TMPR113H	TMPR112	TMPR111	TMPR110	PPR111

Figure 16-4. Format of Priority Specification Flag Registers (PR00L, PR00H, PR01L, PR01H, PR02L, PR02H, PR03L, PR10L, PR10H, PR11L, PR11H, PR12L, PR12H, PR13L) (3/3)

Address: FFFDAH After reset: FFH R/W

Symbol	7	6	<5>	<4>	<3>	<2>	<1>	<0>
PR03L	1	1	TMPR017	TMPR016	TMPR015	TMPR014	DMAPR03	DMAPR02

Address: FFFDEH After reset: FFH R/W

Symbol	7	6	<5>	<4>	<3>	<2>	<1>	<0>
PR13L	1	1	TMPR117	TMPR116	TMPR115	TMPR114	DMAPR13	DMAPR12

XXPR1X	XXPR0X	Priority level selection
0	0	Specify level 0 (high priority level)
0	1	Specify level 1
1	0	Specify level 2
1	1	Specify level 3 (low priority level)

Caution The available registers and bits differ depending on the product. For details about the registers and bits available for each product, see Table 16-2. Be sure to set bits that are not available to the initial value.

16.3.4 External interrupt rising edge enable registers (EGP0, EGP1), external interrupt falling edge enable registers (EGN0, EGN1)

These registers specify the valid edge for INTP0 to INTP11.

The EGP0, EGP1, EGN0, and EGN1 registers can be set by a 1-bit or 8-bit memory manipulation instruction.

Reset signal generation clears these registers to 00H.

Figure 16-5. Format of External Interrupt Rising Edge Enable Registers (EGP0, EGP1) and External Interrupt Falling Edge Enable Registers (EGN0, EGN1)

Address: FFF38H After reset: 00H R/W

Symbol	7	6	5	4	3	2	1	0
EGP0	EGP7	EGP6	EGP5	EGP4	EGP3	EGP2	EGP1	EGP0

Address: FFF39H After reset: 00H R/W

Symbol	7	6	5	4	3	2	1	0
EGN0	EGN7	EGN6	EGN5	EGN4	EGN3	EGN2	EGN1	EGN0

Address: FFF3AH After reset: 00H R/W

Symbol	7	6	5	4	3	2	1	0
EGP1	0	0	0	0	EGP11	EGP10	EGP9	EGP8

Address: FFF3BH After reset: 00H R/W

Symbol	7	6	5	4	3	2	1	0
EGN1	0	0	0	0	EGN11	EGN10	EGN9	EGN8

EGPn	EGNn	INTPn pin valid edge selection (n = 0 to 11)
0	0	Edge detection disabled
0	1	Falling edge
1	0	Rising edge
1	1	Both rising and falling edges

Table 16-3 shows the ports corresponding to the EGPn and EGNn bits.

Table 16-3. Ports Corresponding to EGPn and EGNn bits

Detection Enable Bit		Interrupt Request Signal	64, 80, 100, 128-pin	52-pin	48-pin	30, 32, 36, 40, 44-pin	24, 25-pin	20-pin
EGP0	EGN0	INTP0	√	√	√	√	√	√
EGP1	EGN1	INTP1	√	√	√	√	√	–
EGP2	EGN2	INTP2	√	√	√	√	–	–
EGP3	EGN3	INTP3	√	√	√	√	√	√
EGP4	EGN4	INTP4	√	√	√	√	√	–
EGP5	EGN5	INTP5	√	√	√	√	√	√
EGP6	EGN6	INTP6	√	√	√	–	–	–
EGP7	EGN7	INTP7	√	–	–	–	–	–
EGP8	EGN8	INTP8	√	√	√	–	–	–
EGP9	EGN9	INTP9	√	√	√	–	–	–
EGP10	EGN10	INTP10	√	√	–	–	–	–
EGP11	EGN11	INTP11	√	√	–	–	–	–

Caution When the input port pins used for the external interrupt functions are switched to the output mode, the INTPn interrupt might be generated upon detection of a valid edge. When switching the input port pins to the output mode, set the port mode register (PMxx) to 0 after disabling the edge detection (by setting EGPn and EGNn to 0).

Remarks 1. For edge detection port, see 2.1 Port Function.
2. n = 0 to 11

16.3.5 Program status word (PSW)

The program status word is a register used to hold the instruction execution result and the current status for an interrupt request. The IE flag that sets maskable interrupt enable/disable and the ISP0 and ISP1 flags that controls multiple interrupt servicing are mapped to the PSW.

Besides 8-bit read/write, this register can carry out operations using bit manipulation instructions and dedicated instructions (EI and DI). When a vectored interrupt request is acknowledged, if the BRK instruction is executed, the contents of the PSW are automatically saved into a stack and the IE flag is reset to 0. Upon acknowledgment of a maskable interrupt request, if the value of the priority specification flag register of the acknowledged interrupt is not 00, its value minus 1 is transferred to the ISP0 and ISP1 flags. The PSW contents are also saved into the stack with the PUSH PSW instruction. They are restored from the stack with the RETI, RETB, and POP PSW instructions.

Reset signal generation sets PSW to 06H.

Figure 16-6. Configuration of Program Status Word

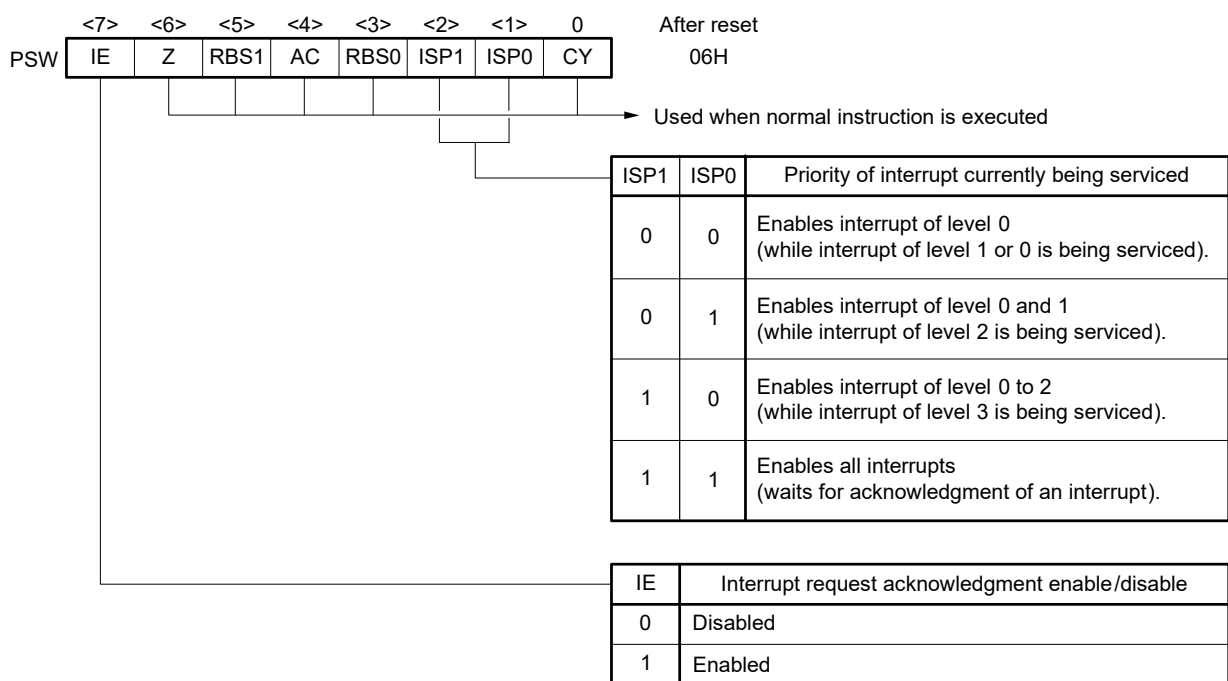

16.4 Interrupt Servicing Operations

16.4.1 Maskable interrupt request acknowledgment

A maskable interrupt request becomes acknowledgeable when the interrupt request flag is set to 1 and the mask (MK) flag corresponding to that interrupt request is cleared to 0. A vectored interrupt request is acknowledged if interrupts are in the interrupt enabled state (when the IE flag is set to 1). However, a low-priority interrupt request is not acknowledged during servicing of a higher priority interrupt request.

The times from generation of a maskable interrupt request until vectored interrupt servicing is performed are listed in Table 16-4 below.

For the interrupt request acknowledgment timing, see **Figures 16-8** and **16-9**.

Table 16-4. Time from Generation of Maskable Interrupt Until Servicing

	Minimum Time	Maximum Time ^{Note}
Servicing time	9 clocks	16 clocks

Note Maximum time does not apply when an instruction from the internal RAM area is executed.

Remark 1 clock: $1/f_{CLK}$ (f_{CLK} : CPU clock)

If two or more maskable interrupt requests are generated simultaneously, the request with a higher priority level specified in the priority specification flag is acknowledged first. If two or more interrupts requests have the same priority level, the request with the highest default priority is acknowledged first.

An interrupt request that is held pending is acknowledged when it becomes acknowledgeable.

Figure 16-7 shows the interrupt request acknowledgment algorithm.

If a maskable interrupt request is acknowledged, the contents are saved into the stacks in the order of PSW, then PC, the IE flag is reset (0), and the contents of the priority specification flag corresponding to the acknowledged interrupt are transferred to the ISP1 and ISP0 flags. The vector table data determined for each interrupt request is the loaded into the PC and branched.

Restoring from an interrupt is possible by using the RETI instruction.

Figure 16-7. Interrupt Request Acknowledgment Processing Algorithm

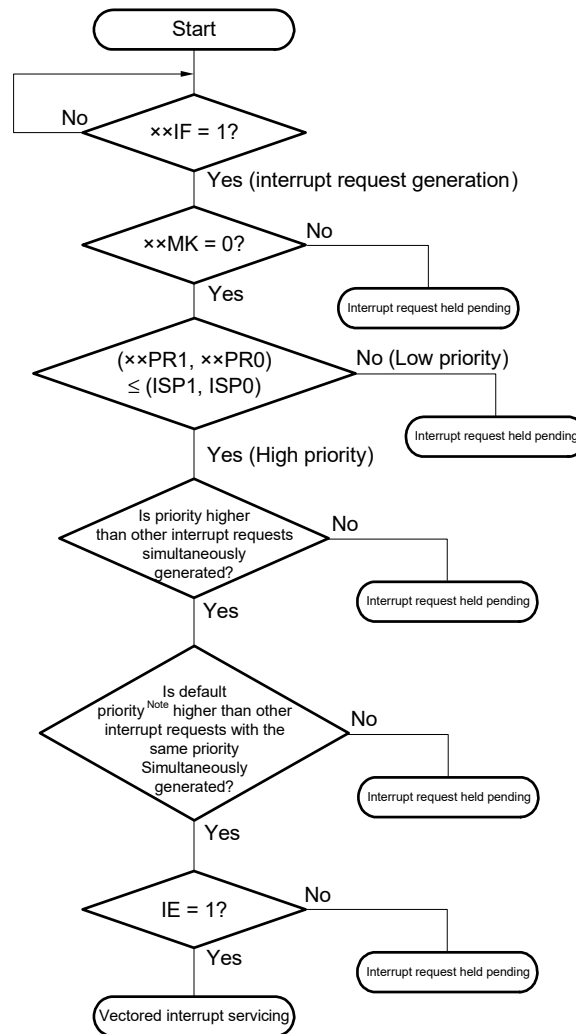

xxIF: Interrupt request flag

xxMK: Interrupt mask flag

xxPR0: Priority specification flag 0

xxPR1: Priority specification flag 1

IE: Flag that controls acknowledgment of maskable interrupt request (1 = Enable, 0 = Disable)

ISP0, ISP1: Flag that indicates the priority level of the interrupt currently being serviced (see Figure 16-6)

Note For the default priority, refer to Table 16-1 Interrupt Source List.

Figure 16-8. Interrupt Request Acknowledgment Timing (Minimum Time)

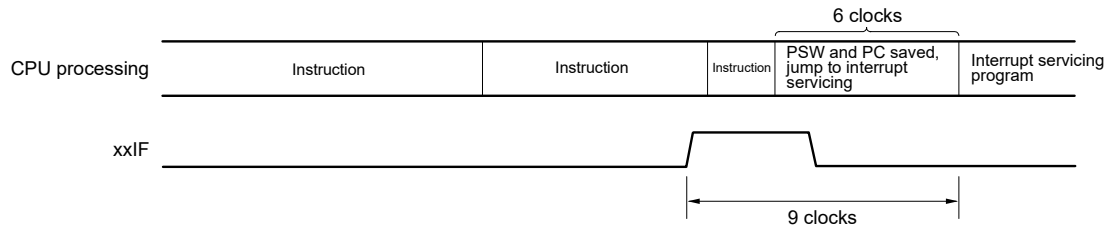

Remark 1 clock: $1/f_{CLK}$ (f_{CLK} : CPU clock)

Figure 16-9. Interrupt Request Acknowledgment Timing (Maximum Time)

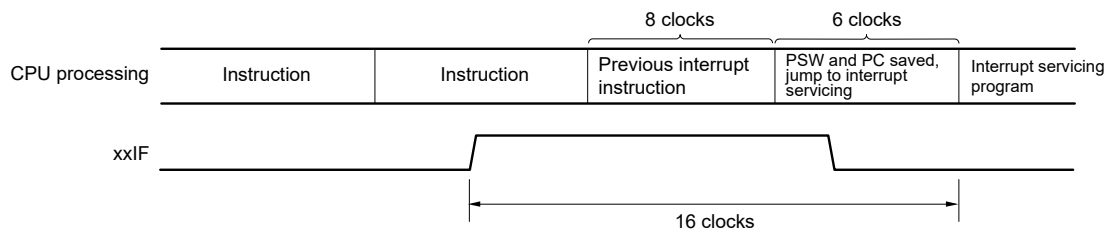

Remark 1 clock: $1/f_{CLK}$ (f_{CLK} : CPU clock)

16.4.2 Software interrupt request acknowledgment

A software interrupt request is acknowledged by BRK instruction execution. Software interrupts cannot be disabled.

If a software interrupt request is acknowledged, the contents are saved into the stacks in the order of the program status word (PSW), then program counter (PC), the IE flag is reset (0), and the contents of the vector table (0007EH, 0007FH) are loaded into the PC and branched.

Restoring from a software interrupt is possible by using the RETB instruction.

Caution Can not use the RETI instruction for restoring from the software interrupt.

16.4.3 Multiple interrupt servicing

Multiple interrupt servicing occurs when another interrupt request is acknowledged during execution of an interrupt.

Multiple interrupt servicing does not occur unless the interrupt request acknowledgment enabled state is selected (IE = 1). When an interrupt request is acknowledged, interrupt request acknowledgment becomes disabled (IE = 0). Therefore, to enable multiple interrupt servicing, it is necessary to set (1) the IE flag with the EI instruction during interrupt servicing to enable interrupt acknowledgment.

Moreover, even if interrupts are enabled, multiple interrupt servicing may not be enabled, this being subject to interrupt priority control. Two types of priority control are available: default priority control and programmable priority control. Programmable priority control is used for multiple interrupt servicing.

In the interrupt enabled state, if an interrupt request with a priority higher than that of the interrupt currently being serviced is generated, it is acknowledged for multiple interrupt servicing. If an interrupt with a priority equal to or lower than that of the interrupt currently being serviced is generated during interrupt servicing, it is not acknowledged for multiple interrupt servicing. However, when setting the IE flag to 1 during the interruption at level 0, other level 0 interruptions can be allowed. Interrupt requests that are not enabled because interrupts are in the interrupt disabled state or because they have a lower priority are held pending. When servicing of the current interrupt ends, the pending interrupt request is acknowledged following execution of at least one main processing instruction execution.

Table 16-5 shows relationship between interrupt requests enabled for multiple interrupt servicing and Figure 16-10 shows multiple interrupt servicing examples.

Table 16-5. Relationship Between Interrupt Requests Enabled for Multiple Interrupt Servicing During Interrupt Servicing

Multiple Interrupt Request Interrupt Being Serviced		Maskable Interrupt Request								Software Interrupt Request
		Priority Level 0 (PR = 00)		Priority Level 1 (PR = 01)		Priority Level 2 (PR = 10)		Priority Level 3 (PR = 11)		
		IE = 1	IE = 0	IE = 1	IE = 0	IE = 1	IE = 0	IE = 1	IE = 0	
Maskable interrupt	ISP1 = 0 ISP0 = 0	O	x	x	x	x	x	x	x	O
	ISP1 = 0 ISP0 = 1	O	x	O	x	x	x	x	x	O
	ISP1 = 1 ISP0 = 0	O	x	O	x	O	x	x	x	O
	ISP1 = 1 ISP0 = 1	O	x	O	x	O	x	O	x	O
Software interrupt		O	x	O	x	O	x	O	x	O

- Remarks**
- O: Multiple interrupt servicing enabled
 - x: Multiple interrupt servicing disabled
 - ISP0, ISP1, and IE are flags contained in the PSW.
 ISP1 = 0, ISP0 = 0: An interrupt of level 1 or level 0 is being serviced.
 ISP1 = 0, ISP0 = 1: An interrupt of level 2 is being serviced.
 ISP1 = 1, ISP0 = 0: An interrupt of level 3 is being serviced.
 ISP1 = 1, ISP0 = 1: Wait for an interrupt acknowledgment (all interrupts are enabled).
 IE = 0: Interrupt request acknowledgment is disabled.
 IE = 1: Interrupt request acknowledgment is enabled.
 - PR is a flag contained in the PR00L, PR00H, PR01L, PR01H, PR02L, PR02H, PR10L, PR10H, PR11L, PR11H, PR12L, and PR12H registers.
 PR = 00: Specify level 0 with $\times\times PR1\times = 0, \times\times PR0\times = 0$ (higher priority level)
 PR = 01: Specify level 1 with $\times\times PR1\times = 0, \times\times PR0\times = 1$
 PR = 10: Specify level 2 with $\times\times PR1\times = 1, \times\times PR0\times = 0$
 PR = 11: Specify level 3 with $\times\times PR1\times = 1, \times\times PR0\times = 1$ (lower priority level)

Figure 16-10. Examples of Multiple Interrupt Servicing (1/2)

Example 1. Multiple interrupt servicing occurs twice

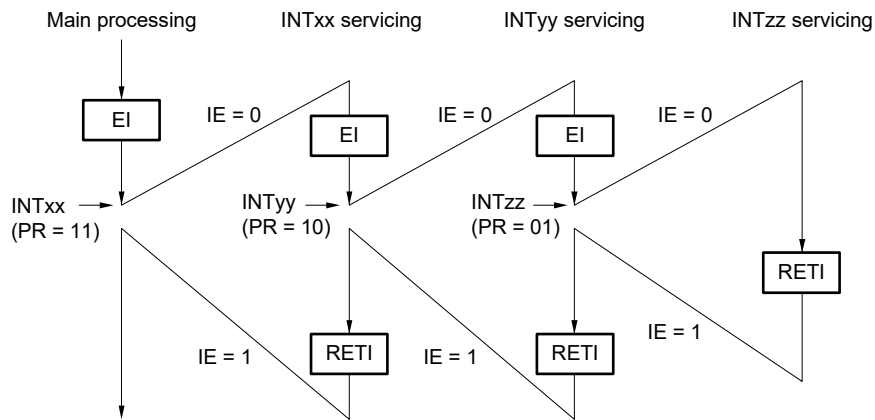

During servicing of interrupt INTxx, two interrupt requests, INTyy and INTzz, are acknowledged, and multiple interrupt servicing takes place. Before each interrupt request is acknowledged, the EI instruction must always be issued to enable interrupt request acknowledgment.

Example 2. Multiple interrupt servicing does not occur due to priority control

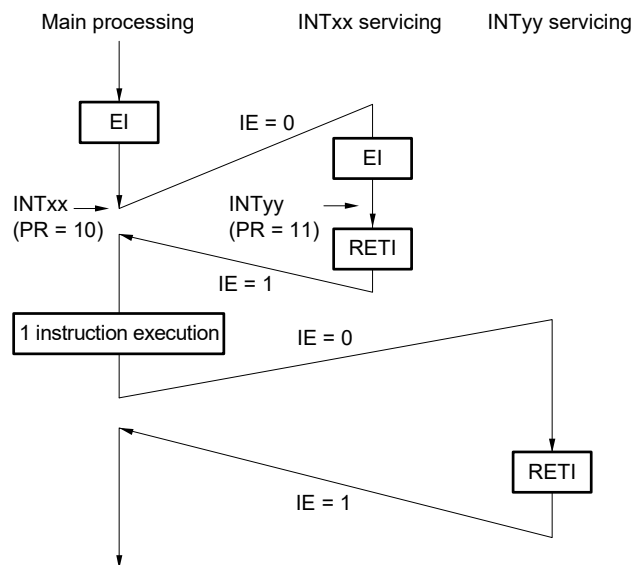

Interrupt request INTyy issued during servicing of interrupt INTxx is not acknowledged because its priority is lower than that of INTxx, and multiple interrupt servicing does not take place. The INTyy interrupt request is held pending, and is acknowledged following execution of one main processing instruction.

- PR = 00: Specify level 0 with $\times\times PR1\times = 0$, $\times\times PR0\times = 0$ (higher priority level)
- PR = 01: Specify level 1 with $\times\times PR1\times = 0$, $\times\times PR0\times = 1$
- PR = 10: Specify level 2 with $\times\times PR1\times = 1$, $\times\times PR0\times = 0$
- PR = 11: Specify level 3 with $\times\times PR1\times = 1$, $\times\times PR0\times = 1$ (lower priority level)
- IE = 0: Interrupt request acknowledgment is disabled
- IE = 1: Interrupt request acknowledgment is enabled.

Figure 16-10. Examples of Multiple Interrupt Servicing (2/2)

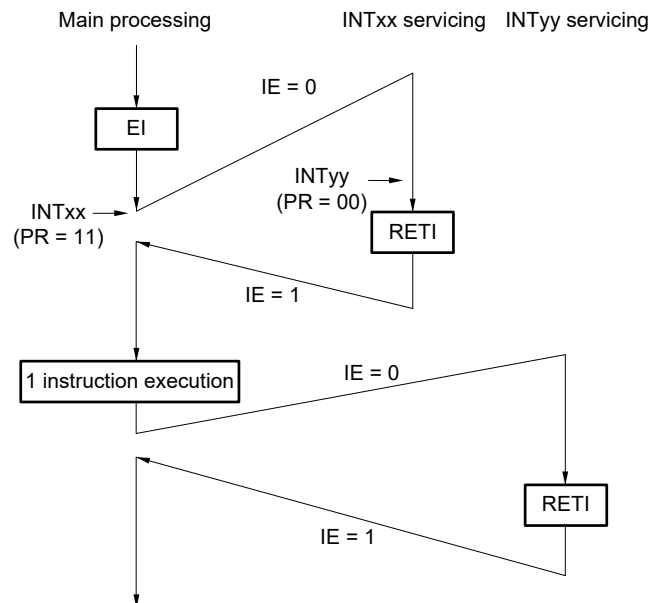
Example 3. Multiple interrupt servicing does not occur because interrupts are not enabled

Interrupts are not enabled during servicing of interrupt INTxx (EI instruction is not issued), therefore, interrupt request INTyy is not acknowledged and multiple interrupt servicing does not take place. The INTyy interrupt request is held pending, and is acknowledged following execution of one main processing instruction.

PR = 00: Specify level 0 with $\times\times PR1\times = 0$, $\times\times PR0\times = 0$ (higher priority level)

PR = 01: Specify level 1 with $\times\times PR1\times = 0$, $\times\times PR0\times = 1$

PR = 10: Specify level 2 with $\times\times PR1\times = 1$, $\times\times PR0\times = 0$

PR = 11: Specify level 3 with $\times\times PR1\times = 1$, $\times\times PR0\times = 1$ (lower priority level)

IE = 0: Interrupt request acknowledgment is disabled

IE = 1: Interrupt request acknowledgment is enabled.

16.4.4 Interrupt request hold

There are instructions where, even if an interrupt request is issued while the instructions are being executed, interrupt request acknowledgment is held pending until the end of execution of the next instruction. These instructions (interrupt request hold instructions) are listed below.

- MOV PSW, #byte
- MOV PSW, A
- MOV1 PSW. bit, CY
- SET1 PSW. bit
- CLR1 PSW. bit
- RETB
- RETI
- POP PSW
- BTCLR PSW. bit, \$addr20
- EI
- DI
- SKC
- SKNC
- SKZ
- SKNZ
- SKH
- SKNH
- Write instructions for the IF0L, IF0H, IF1L, IF1H, IF2L, IF2H, IF3L, MK0L, MK0H, MK1L, MK1H, MK2L, MK2H, MK3L, PR00L, PR00H, PR01L, PR01H, PR02L, PR02H, PR03L, PR10L, PR10H, PR11L, PR11H, PR12L, PR12H, and PR13L registers

Figure 16-11 shows the timing at which interrupt requests are held pending.

Figure 16-11. Interrupt Request Hold

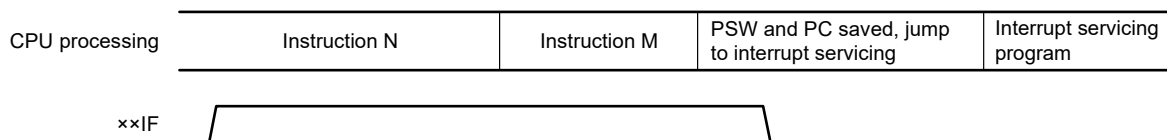

- Remarks**
1. Instruction N: Interrupt request hold instruction
 2. Instruction M: Instruction other than interrupt request hold instruction

CHAPTER 17 KEY INTERRUPT FUNCTION

The number of key interrupt input channels differs, depending on the product.

	20, 24, 25, 30, 32, 36-pin	40, 44-pin	48-pin	52, 64, 80, 100, 128-pin
Key interrupt input channels	–	4 ch	6 ch	8 ch

17.1 Functions of Key Interrupt

A key interrupt (INTKR) can be generated by inputting a falling edge to the key interrupt input pins (KR0 to KR7).

Table 17-1. Assignment of Key Interrupt Detection Pins

Key interrupt input pins	Key return mode register (KRM)
KR0	KRM0
KR1	KRM1
KR2	KRM2
KR3	KRM3
KR4	KRM4
KR5	KRM5
KR6	KRM6
KR7	KRM7

Remark KR0 to KR3: Available in the 40- and 44-pin products.

KR0 to KR5: Available in the 48-pin products.

KR0 to KR7: Available in the 52-, 64-, 80-, 100-, and 128-pin products.

17.2 Configuration of Key Interrupt

The key interrupt includes the following hardware.

Table 17-2. Configuration of Key Interrupt

Item	Configuration
Control register	Key return mode register (KRM) Port mode register (PM7)

Figure 17-1. Block Diagram of Key Interrupt

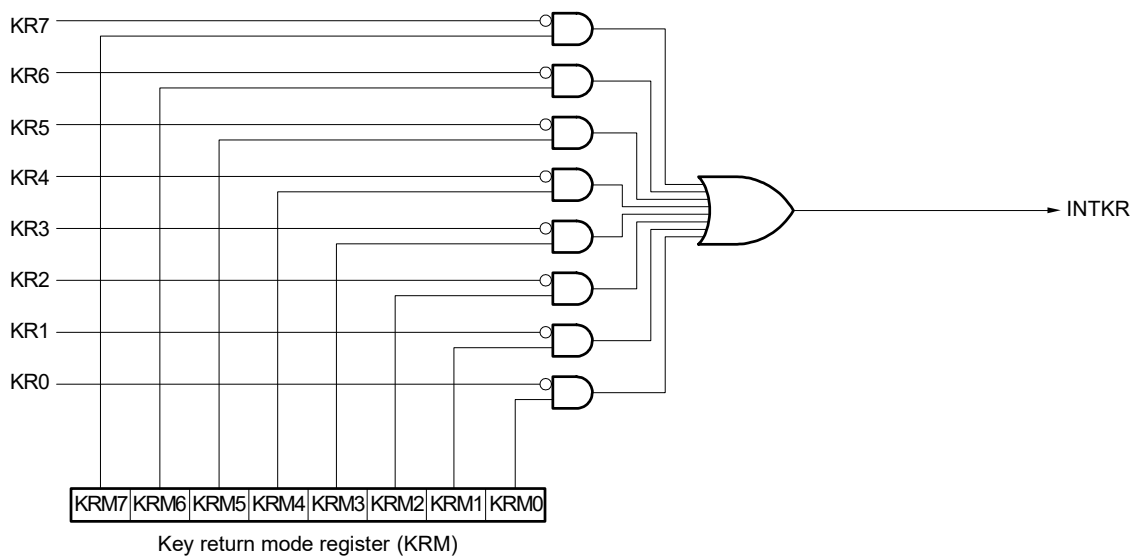

Remark KR0 to KR3: Available in the 40- and 44-pin products.
 KR0 to KR5: Available in the 48-pin products.
 KR0 to KR7: Available in the 52-, 64-, 80-, 100-, and 128-pin products.

17.3 Register Controlling Key Interrupt

The key interrupt function is controlled by the following registers.

- Key return mode register (KRM)
- Port mode register (PM7)

17.3.1 Key return mode register (KRM)

KRM register controls the KR0 to KR7 signals.

The KRM register can be set by a 1-bit or 8-bit memory manipulation instruction.

Reset signal generation clears this register to 00H.

Figure 17-2. Format of Key Return Mode Register (KRM)

Address: FFF37H After reset: 00H R/W

Symbol	7	6	5	4	3	2	1	0
KRM	KRM7	KRM6	KRM5	KRM4	KRM3	KRM2	KRM1	KRM0

KRMn	Key interrupt mode control
0	Does not detect key interrupt signal
1	Detects key interrupt signal

- Cautions**
1. The on-chip pull-up resistors can be applied by setting the corresponding key interrupt input pins (bits) in pull-up resistor register 7 (PU7) to 1.
 2. An interrupt will be generated if the target bit of the KRM register is set while a low level is being input to the key interrupt input pin. To ignore this interrupt, set the KRM register after disabling interrupt servicing by using the interrupt mask flag. Afterward, clear the interrupt request flag and enable interrupt servicing after waiting for the key interrupt input low-level width (see AC characteristics).
 3. The pins not used in the key interrupt mode can be used as normal ports.

- Remarks**
1. n = 0 to 7
 2. KR0 to KR3: Available in the 40- and 44-pin products.
 KR0 to KR5: Available in the 48-pin products.
 KR0 to KR7: Available in the 52-, 64-, 80-, 100-, and 128-pin products.

17.3.2 Port mode register 7 (PM7)

When port 7 is used as the key interrupt input pins (KR0 to KR7), set the PM7n bit to 1. The output latches of P7n at this time may be 0 or 1. The PM7 register can be set by a 1-bit or 8-bit memory manipulation instruction. Reset signal generation sets this register to FFH.

Use of an on-chip pull-up resistor can be specified in 1-bit units by the pull-up resistor option register 7 (PU7).

Figure 17-3. Format of Port Mode Register 7

Address: FFF27H After reset: FFH R/W

Symbol	7	6	5	4	3	2	1	0
PM7	PM77	PM76	PM75	PM74	PM73	PM72	PM71	PM70

PM7n	P7n pin I/O mode selection (n = 0 to 7)
0	Output mode (output buffer on)
1	Input mode (output buffer off)

CHAPTER 18 STANDBY FUNCTION

18.1 Standby Function

The standby function reduces the operating current of the system, and the following three modes are available.

(1) HALT mode

HALT instruction execution sets the HALT mode. In the HALT mode, the CPU operation clock is stopped. If the high-speed system clock oscillator, high-speed on-chip oscillator, or subsystem clock oscillator is operating before the HALT mode is set, oscillation of each clock continues. In this mode, the operating current is not decreased as much as in the STOP mode, but the HALT mode is effective for restarting operation immediately upon interrupt request generation and carrying out intermittent operations frequently.

(2) STOP mode

STOP instruction execution sets the STOP mode. In the STOP mode, the high-speed system clock oscillator and high-speed on-chip oscillator stop, stopping the whole system, thereby considerably reducing the CPU operating current.

Because this mode can be cleared by an interrupt request, it enables intermittent operations to be carried out. However, because a wait time is required to secure the oscillation stabilization time after the STOP mode is released when the X1 clock is selected, select the HALT mode if it is necessary to start processing immediately upon interrupt request generation.

(3) SNOOZE mode

In the case of CSIp or UARTq data reception and an A/D conversion request by the timer trigger signal (the interrupt request signal (INTRTC/INTIT)), the STOP mode is exited, the CSIp or UARTq data is received without operating the CPU, and A/D conversion is performed. This can only be specified when the high-speed on-chip oscillator is selected for the CPU/peripheral hardware clock (f_{CLK}).

In either of these two modes, all the contents of registers, flags and data memory just before the standby mode is set are held. The I/O port output latches and output buffer statuses are also held.

- Cautions**
1. **The STOP mode can be used only when the CPU is operating on the main system clock. Do not set to the STOP mode while the CPU operates with the subsystem clock. The HALT mode can be used when the CPU is operating on either the main system clock or the subsystem clock.**
 2. **When shifting to the STOP mode, be sure to stop the peripheral hardware operation operating with main system clock before executing STOP instruction (except SNOOZE mode setting unit).**
 3. **When using CSIp, UARTq, or the A/D converter in the SNOOZE mode, set up serial standby control register m (SSCm) and A/D converter mode register 2 (ADM2) before switching to the STOP mode. For details, see 12.3 Registers Controlling Serial Array Unit and 11.3 Registers Controlling A/D Converter.**
 4. **The following sequence is recommended for power consumption reduction of the A/D converter when the standby function is used: First clear bit 7 (ADCS) and bit 0 (ADCE) of A/D converter mode register 0 (ADM0) to 0 to stop the A/D conversion operation, and then execute the STOP instruction.**
 5. **It can be selected by the WDTON bit of the option byte and the WUTMMCK0 bit of the subsystem clock supply mode control register (OSMC) whether the low-speed on-chip oscillator continues oscillating or stops in the HALT or STOP mode. For details, see 5.1 (3) Low-speed on-chip oscillator clock (Low-speed On-chip oscillator).**

Remark 20 to 64-pin products: p = 00; q = 0; m = 0
80 to 128-pin products: p = 00, 20; q = 0, 2; m = 0, 1

18.2 Registers controlling standby function

The registers which control the standby function are described below.

- Subsystem clock supply mode control register (OSMC)
- Oscillation stabilization time counter status register (OSTC)
- Oscillation stabilization time select register (OSTS)

Remark For details of registers described above, see **CHAPTER 5 CLOCK GENERATOR**. For registers which control the SNOOZE mode, **CHAPTER 11 A/D CONVERTER** and **CHAPTER 12 SERIAL ARRAY UNIT**.

18.3 Standby Function Operation

18.3.1 HALT mode

(1) HALT mode

The HALT mode is set by executing the HALT instruction. HALT mode can be set regardless of whether the CPU clock before the setting was the high-speed system clock, high-speed on-chip oscillator clock, or subsystem clock.

The operating statuses in the HALT mode are shown below.

Caution Because the interrupt request signal is used to clear the HALT mode, if the interrupt mask flag is 0 (the interrupt processing is enabled) and the interrupt request flag is 1 (the interrupt request signal is generated), the HALT mode is not entered even if the HALT instruction is executed in such a situation.

Table 18-1. Operating Statuses in HALT Mode (1/2)

HALT Mode Setting		When HALT Instruction Is Executed While CPU Is Operating on Main System Clock					
		When CPU Is Operating on High-speed On-chip Oscillator Clock (f_{IH})	When CPU Is Operating on X1 Clock (f_x)	When CPU Is Operating on External Main System Clock (f_{EX})			
System clock		Clock supply to the CPU is stopped					
Main system clock	f_{IH}	Operation continues (cannot be stopped)	Operation disabled				
	f_x	Operation disabled	Operation continues (cannot be stopped)	Cannot operate			
	f_{EX}		Cannot operate	Operation continues (cannot be stopped)			
Subsystem clock	f_{XT}	Status before HALT mode was set is retained					
	f_{EXS}						
f_{IL}	Set by bits 0 (WDSTBYON) and 4 (WDTON) of option byte (000C0H), and WUTMMCK0 bit of subsystem clock supply mode control register (OSMC)						
CPU		Operation stopped					
Code flash memory		Operation stopped (operable when DMA is executed)					
Data flash memory							
RAM							
Port (latch)		Status before HALT mode was set is retained					
Timer array unit		Operable					
Real-time clock (RTC)							
12-bit interval timer							
Watchdog timer		See CHAPTER 10 WATCHDOG TIMER.					
Clock output/buzzer output		Operable					
A/D converter							
Serial array unit (SAU)							
Serial interface (IICA)							
Multiplier and divider/multiply-accumulator							
DMA controller							
Power-on-reset function							
Voltage detection function							
External interrupt							
Key interrupt function							
CRC operation function	High-speed CRC				In the calculation of the RAM area, operable when DMA is executed only		
	General-purpose CRC						
RAM parity error detection function					Operable when DMA is executed only		
RAM guard function							
SFR guard function							
Illegal-memory access detection function							

Remark Operation stopped: Operation is automatically stopped before switching to the HALT mode.

Operation disabled: Operation is stopped before switching to the HALT mode.

f_{IH} : High-speed on-chip oscillator clock f_{EX} : External main system clock

f_{IL} : Low-speed on-chip oscillator clock f_{XT} : XT1 clock

f_x : X1 clock f_{EXS} : External subsystem clock

Table 18-1. Operating Statuses in HALT Mode (2/2)

HALT Mode Setting Item		When HALT Instruction Is Executed While CPU Is Operating on Subsystem Clock	
		When CPU Is Operating on XT1 Clock (f_{XT})	When CPU Is Operating on External Subsystem Clock (f_{EXS})
System clock		Clock supply to the CPU is stopped	
Main system clock	f_{IH}	Operation disabled	
	f_X		
	f_{EX}		
Subsystem clock	f_{XT}	Operation continues (cannot be stopped)	Cannot operate
	f_{EXS}	Cannot operate	Operation continues (cannot be stopped)
f_{IL}		Set by bits 0 (WDSTBYON) and 4 (WDTON) of option byte (000C0H), and WUTMMCK0 bit of subsystem clock supply mode control register (OSMC) <ul style="list-style-type: none"> • WUTMMCK0 = 1: Oscillates • WUTMMCK0 = 0 and WDTON = 0: Stops • WUTMMCK0 = 0, WDTON = 1, and WDSTBYON = 1: Oscillates • WUTMMCK0 = 0, WDTON = 1, and WDSTBYON = 0: Stops 	
CPU		Operation stopped	
Code flash memory		Operation stopped (operable when DMA is executed)	
Data flash memory			
RAM			
Port (latch)		Status before HALT mode was set is retained	
Timer array unit		Operates when the RTCLPC bit is 0 (operation is disabled when the RTCLPC bit is not 0).	
Real-time clock (RTC)		Operable	
12-bit interval timer			
Watchdog timer			
Clock output/buzzer output		Operates when the RTCLPC bit is 0 (operation is disabled when the RTCLPC bit is not 0).	
A/D converter		Operation disabled	
Serial array unit (SAU)		Operates when the RTCLPC bit is 0 (operation is disabled when the RTCLPC bit is not 0).	
Serial interface (IICA)		Operation disabled	
Multiplier and divider/multiply-accumulator		Operates when the RTCLPC bit is 0 (operation is disabled when the RTCLPC bit is not 0).	
DMA controller			
Power-on-reset function			
Voltage detection function		Operable	
External interrupt			
Key interrupt function			
CRC operation function	High-speed CRC	Operation disabled	
	General-purpose CRC	In the calculation of the RAM area, operable when DMA is executed only	
RAM parity error detection function		Operable when DMA is executed only	
RAM guard function			
SFR guard function			
Illegal-memory access detection function			

Remark Operation stopped: Operation is automatically stopped before switching to the HALT mode.
 Operation disabled: Operation is stopped before switching to the HALT mode.
 f_{IH} : High-speed on-chip oscillator clock f_{EX} : External main system clock
 f_{IL} : Low-speed on-chip oscillator clock f_{XT} : XT1 clock
 f_X : X1 clock f_{EXS} : External subsystem clock

(2) HALT mode release

The HALT mode can be released by the following two sources.

(a) Release by unmasked interrupt request

When an unmasked interrupt request is generated, the HALT mode is released. If interrupt acknowledgment is enabled, vectored interrupt servicing is carried out. If interrupt acknowledgment is disabled, the next address instruction is executed.

Figure 18-1. HALT Mode Release by Interrupt Request Generation

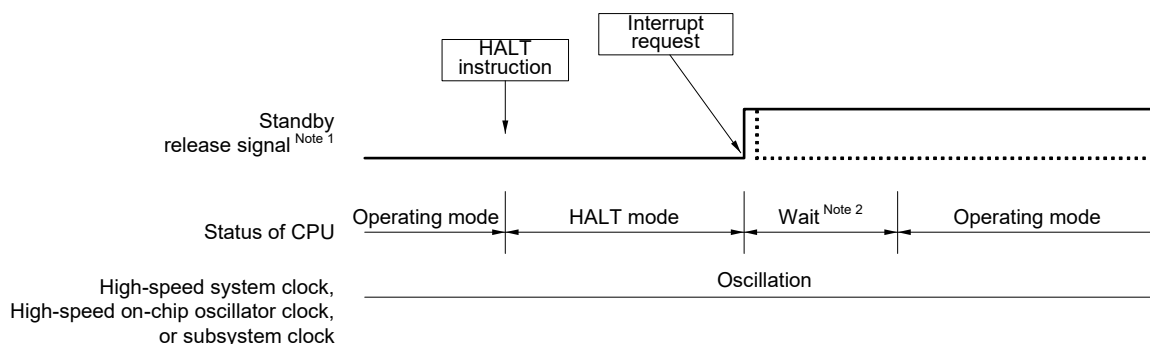

Notes 1. For details of the standby release signal, see **Figure 16-1**.

2. Wait time for HALT mode release

- When vectored interrupt servicing is carried out
 - Main system clock: 15 to 16 clock
 - Subsystem clock (RTCLPC = 0): 10 to 11 clock
 - Subsystem clock (RTCLPC = 1): 11 to 12 clock
- When vectored interrupt servicing is not carried out
 - Main system clock: 9 to 10 clock
 - Subsystem clock (RTCLPC = 0): 4 to 5 clock
 - Subsystem clock (RTCLPC = 1): 5 to 6 clock

Remark The broken lines indicate the case when the interrupt request which has released the standby mode is acknowledged.

(b) Release by reset signal generation

When the reset signal is generated, HALT mode is released, and then, as in the case with a normal reset operation, the program is executed after branching to the reset vector address.

Figure 18-2. HALT Mode Release by Reset (1/2)

(1) When high-speed on-chip oscillator clock is used as CPU clock

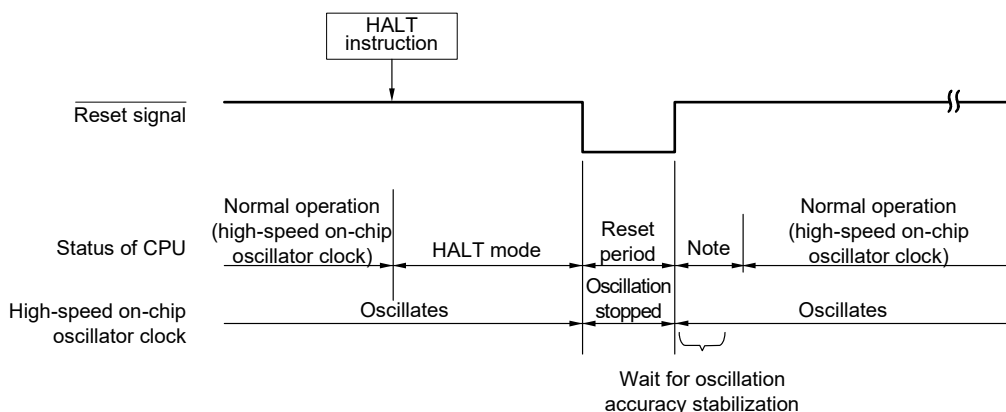

(2) When high-speed system clock is used as CPU clock

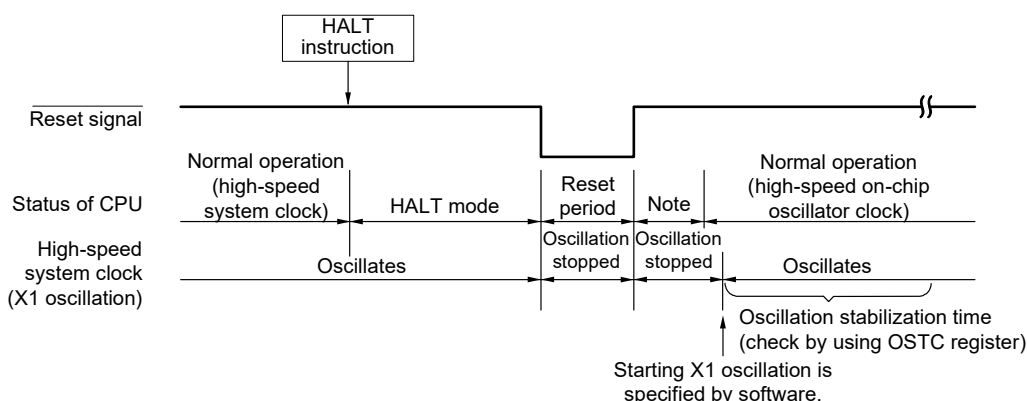

Note For the reset processing time, see **CHAPTER 19 RESET FUNCTION**.
 For the reset processing time of the power-on-reset circuit (POR) and voltage detector (LVD), see **CHAPTER 20 POWER-ON-RESET CIRCUIT**.

Figure 18-2. HALT Mode Release by Reset (2/2)

(3) When subsystem clock is used as CPU clock

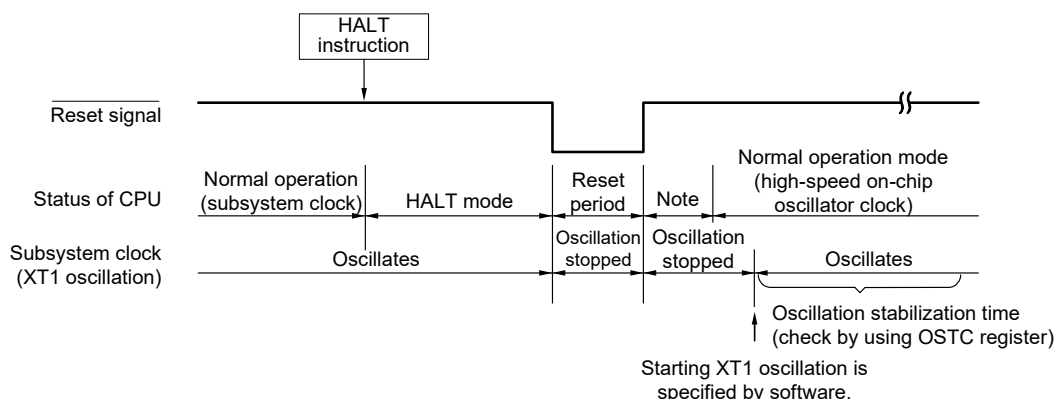

Note For the reset processing time, see **CHAPTER 19 RESET FUNCTION**.
 For the reset processing time of the power-on-reset circuit (POR) and voltage detector (LVD), see **CHAPTER 20 POWER-ON-RESET CIRCUIT**.

18.3.2 STOP mode

(1) STOP mode setting and operating statuses

The STOP mode is set by executing the STOP instruction, and it can be set only when the CPU clock before the setting was the high-speed on-chip oscillator clock, X1 clock, or external main system clock.

Caution Because the interrupt request signal is used to clear the STOP mode, if the interrupt mask flag is 0 (the interrupt processing is enabled) and the interrupt request flag is 1 (the interrupt request signal is generated), the STOP mode is immediately cleared if set when the STOP instruction is executed in such a situation. Accordingly, once the STOP instruction is executed, the system returns to its normal operating mode after the elapse of release time from the STOP mode.

Remark 20 to 64-pin products: p = 00; q = 0; m = 0
 80 to 128-pin products: p = 00, 20; q = 0, 2; m = 0, 1

The operating statuses in the STOP mode are shown below.

Table 18-2. Operating Statuses in STOP Mode

STOP Mode Setting		When STOP Instruction Is Executed While CPU Is Operating on Main System Clock		
		When CPU Is Operating on High-speed on-chip oscillator clock (f_{IH})	When CPU Is Operating on X1 Clock (f_x)	When CPU Is Operating on External Main System Clock (f_{EX})
System clock		Clock supply to the CPU is stopped		
Main system clock	f_{IH}	Stopped		
	f_x			
	f_{EX}			
Subsystem clock	f_{XT}	Status before STOP mode was set is retained		
	f_{EXS}			
f_{IL}		Set by bits 0 (WDSTBYON) and 4 (WDTON) of option byte (000C0H), and WUTMMCK0 bit of subsystem clock supply mode control register (OSMC) ● WUTMMCK0 = 1: Oscillates ● WUTMMCK0 = 0 and WDTON = 0: Stops ● WUTMMCK0 = 0, WDTON = 1, and WDSTBYON = 1: Oscillates ● WUTMMCK0 = 0, WDTON = 1, and WDSTBYON = 0: Stops		
CPU		Operation stopped		
Code flash memory				
Data flash memory				
RAM				
Port (latch)		Status before STOP mode was set is retained		
Timer array unit		Operation disabled		
Real-time clock (RTC)		Operable		
12-bit interval timer				
Watchdog timer		See CHAPTER 10 WATCHDOG TIMER.		
Clock output/buzzer output		Operates when the subsystem clock is selected as the clock source for counting and the RTCLPC bit is 0 (operation is disabled when a clock other than the subsystem clock is selected and the RTCLPC bit is not 0).		
A/D converter		Wakeup operation is enabled (switching to the SNOOZE mode)		
Serial array unit (SAU)		Wakeup operation is enabled only for CSIp and UARTq (switching to the SNOOZE mode) Operation is disabled for anything other than CSIp and UARTq		
Serial interface (IICA)		Wakeup by address match operable		
Multiplier and divider/multiply-accumulator		Operation disabled		
DMA controller				
Power-on-reset function		Operable		
Voltage detection function				
External interrupt				
Key interrupt function				
CRC operation function	High-speed CRC	Operation stopped		
	General-purpose CRC			
RAM parity error detection function				
RAM guard function				
SFR guard function				
Illegal-memory access detection function				

Remarks 1. Operation stopped: Operation is automatically stopped before switching to the STOP mode.

Operation disabled: Operation is stopped before switching to the STOP mode.

f_{IH} : High-speed on-chip oscillator clock f_{IL} : Low-speed on-chip oscillator clock

f_x : X1 clock f_{EX} : External main system clock

f_{XT} : XT1 clock f_{EXS} : External subsystem clock

2. 20 to 64-pin products: $p = 00$; $q = 0$

80 to 128-pin products: $p = 00, 20$; $q = 0, 2$

(2) STOP mode release

The STOP mode can be released by the following two sources.

(a) Release by unmasked interrupt request

When an unmasked interrupt request is generated, the STOP mode is released. After the oscillation stabilization time has elapsed, if interrupt acknowledgment is enabled, vectored interrupt servicing is carried out. If interrupt acknowledgment is disabled, the next address instruction is executed.

Figure 18-3. STOP Mode Release by Interrupt Request Generation (1/2)

(1) When high-speed on-chip oscillator clock is used as CPU clock

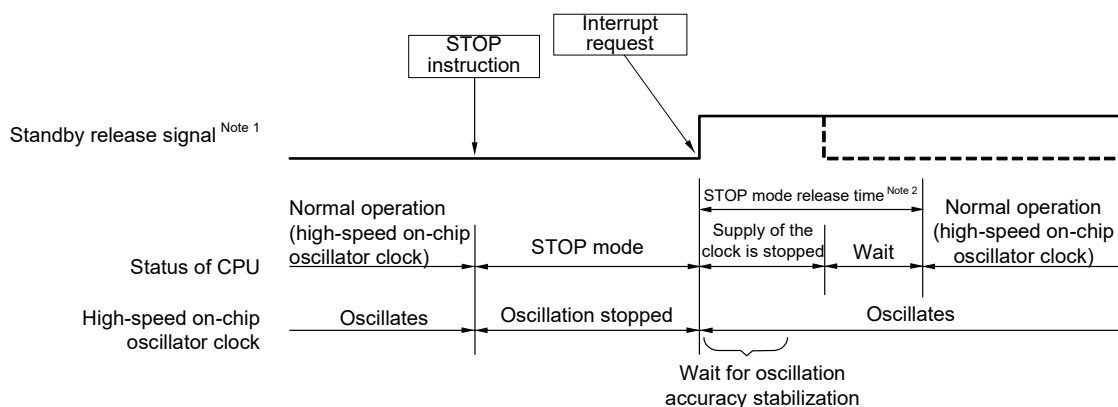

- Notes**
1. For details of the standby release signal, see **Figure 16-1**.
 2. STOP mode release time
 - Supply of the clock is stopped: 18 μ s to 65 μ s
 - Wait
 - When vectored interrupt servicing is carried out: 7 clocks
 - When vectored interrupt servicing is not carried out: 1 clock

- Remarks**
1. The clock supply stop time varies depending on the temperature conditions and STOP mode period.
 2. The broken lines indicate the case when the interrupt request that has released the standby mode is acknowledged.

Figure 18-3. STOP Mode Release by Interrupt Request Generation (2/2)

(2) When high-speed system clock (X1 oscillation) is used as CPU clock

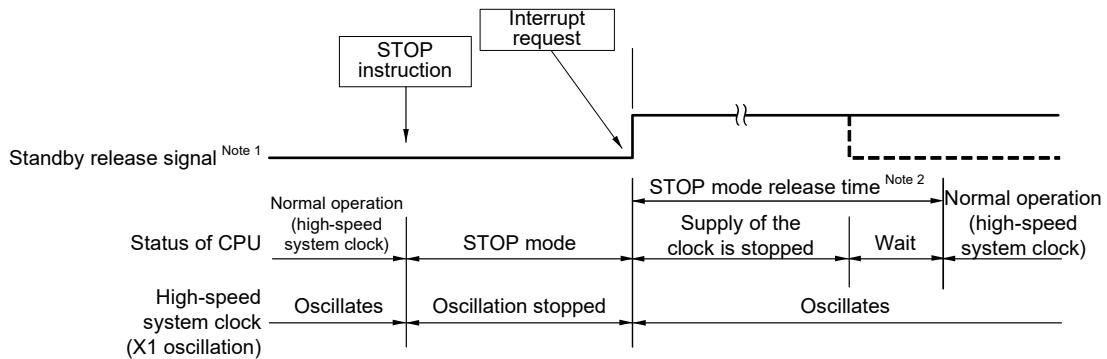

Notes 1. For details of the standby release signal, see Figure 16-1.

2. STOP mode release time

Supply of the clock is stopped: 18 μs to "whichever is longer 65 μs and the oscillation stabilization time (set by OSTs)"

Wait

- When vectored interrupt servicing is carried out: 10 to 11 clocks
- When vectored interrupt servicing is not carried out: 4 to 5 clocks

(3) When high-speed system clock (external clock input) is used as CPU clock

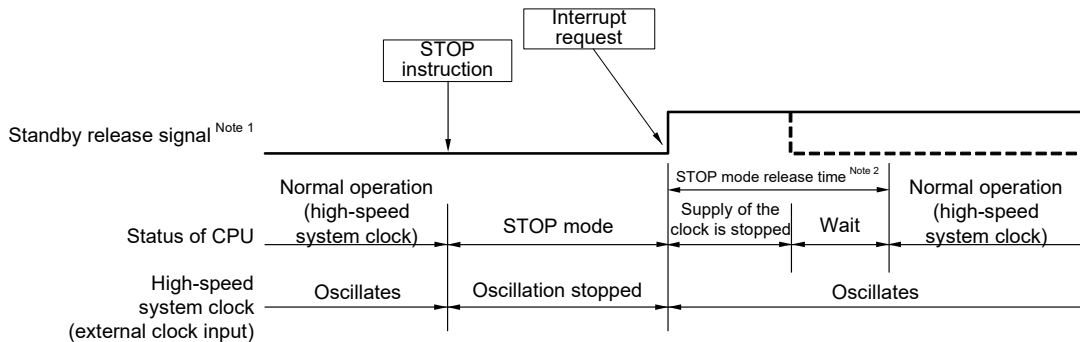

Notes 1. For details of the standby release signal, see Figure 16-1.

2. STOP mode release time

Supply of the clock is stopped: 18 μs to 65 μs

Wait

- When vectored interrupt servicing is carried out: 7 clocks
- When vectored interrupt servicing is not carried out: 1 clock

Caution To reduce the oscillation stabilization time after release from the STOP mode while CPU operates based on the high-speed system clock (X1 oscillation), switch the clock to the high-speed on-chip oscillator clock temporarily before executing the STOP instruction.

Remarks 1. The clock supply stop time varies depending on the temperature conditions and STOP mode period.
 2. The broken lines indicate the case when the interrupt request that has released the standby mode is acknowledged.

(b) Release by reset signal generation

When the reset signal is generated, STOP mode is released, and then, as in the case with a normal reset operation, the program is executed after branching to the reset vector address.

Figure 18-4. STOP Mode Release by Reset

(1) When high-speed on-chip oscillator clock is used as CPU clock

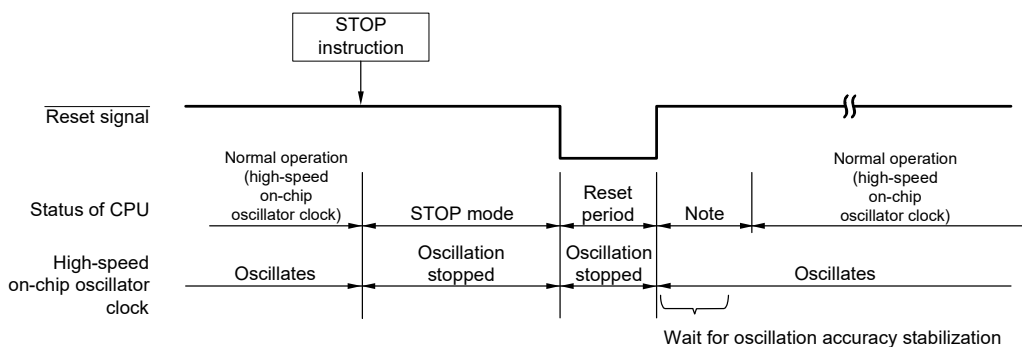

(2) When high-speed system clock is used as CPU clock

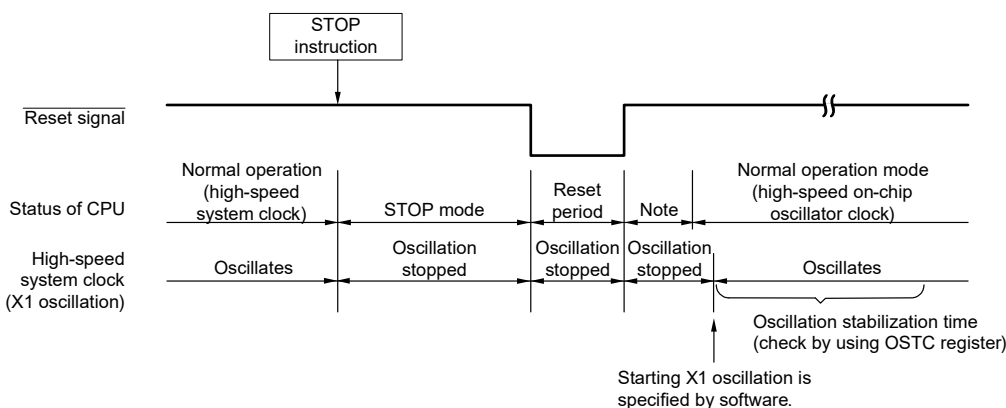

Note For the reset processing time, see **CHAPTER 19 RESET FUNCTION**.
 For the reset processing time of the power-on-reset circuit (POR) and voltage detector (LVD), see **CHAPTER 20 POWER-ON-RESET CIRCUIT**.

18.3.3 SNOOZE mode

(1) SNOOZE mode setting and operating statuses

The SNOOZE mode can only be specified for CSIp, UARTq, or the A/D converter. Note that this mode can only be specified if the CPU clock is the high-speed on-chip oscillator clock.

When using CSIp or UARTq in the SNOOZE mode, set the SWCm bit of the serial standby control register m (SSCm) to 1 immediately before switching to the STOP mode. For details, see **12.3 Registers Controlling Serial Array Unit**. When using the A/D converter in the SNOOZE mode, set the AWC bit of the A/D converter mode register 2 (ADM2) to 1 immediately before switching to the STOP mode. For details, see **11.3 Registers Controlling A/D Converter**.

Remark 20 to 64-pin products: p = 00; q = 0; m = 0
80 to 128-pin products: p = 00, 20; q = 0, 2; m = 0, 1

In SNOOZE mode transition, wait status to be only following time.

Transition time from STOP mode to SNOOZE mode: 18 μ s to 65 μ s

Remark Transition time from STOP mode to SNOOZE mode varies depending on the temperature conditions and the STOP mode period.

Transition time from SNOOZE mode to normal operation:

- When vectored interrupt servicing is carried out:
 - HS (High-speed main) mode : "4.99 μ s to 9.44 μ s" + 7 clocks
 - LS (Low-speed main) mode : "1.10 μ s to 5.08 μ s" + 7 clocks
 - LV (Low-voltage main) mode : "16.58 μ s to 25.40 μ s" + 7 clocks
- When vectored interrupt servicing is not carried out:
 - HS (High-speed main) mode : "4.99 μ s to 9.44 μ s" + 1 clock
 - LS (Low-speed main) mode : "1.10 μ s to 5.08 μ s" + 1 clock
 - LV (Low-voltage main) mode : "16.58 μ s to 25.40 μ s" + 1 clock

The operating statuses in the SNOOZE mode are shown below.

Table 18-3. Operating Statuses in SNOOZE Mode

STOP Mode Setting		When Inputting CSIp/UARTq Data Reception Signal or A/D Converter Timer Trigger Signal While in STOP Mode
Item		When CPU Is Operating on High-speed on-chip oscillator clock (f_{IH})
System clock		Clock supply to the CPU is stopped
Main system clock	f_{IH}	Operation started
	f_X	Stopped
	f_{EX}	
Subsystem clock	f_{XT}	Use of the status while in the STOP mode continues
	f_{EXS}	
f_{IL}		Set by bits 0 (WDSTBYON) and 4 (WDTON) of option byte (000C0H), and WUTMMCK0 bit of subsystem clock supply mode control register (OSMC) <ul style="list-style-type: none"> • WUTMMCK0 = 1: Oscillates • WUTMMCK0 = 0 and WDTON = 0: Stops • WUTMMCK0 = 0, WDTON = 1, and WDSTBYON = 1: Oscillates • WUTMMCK0 = 0, WDTON = 1, and WDSTBYON = 0: Stops
CPU		Operation stopped
Code flash memory		
Data flash memory		
RAM		Operation stopped (operable when DMA is executed)
Port (latch)		Use of the status while in the STOP mode continues
Timer array unit		Operation disabled
Real-time clock (RTC)		Operable
12-bit interval timer		
Watchdog timer		See CHAPTER 10 WATCHDOG TIMER.
Clock output/buzzer output		Operates when the subsystem clock is selected as the clock source for counting and the RTCLPC bit is 0 (operation is disabled when a clock other than the subsystem clock is selected and the RTCLPC bit is not 0).
A/D converter		Operable
Serial array unit (SAU)		Operable only CSIp and UARTq only. Operation disabled other than CSIp and UARTq.
Serial interface (IICA)		Operation disabled
Multiplier and divider/multiply-accumulator		
DMA controller		
Power-on-reset function		Operable
Voltage detection function		
External interrupt		
Key interrupt function		
CRC operation function	High-speed CRC	Operation disabled
	General-purpose CRC	
RAM parity error detection function		
RAM guard function		
SFR guard function		
Illegal-memory access detection function		

Remarks 1. Operation stopped: Operation is automatically stopped before switching to the SNOOZE mode.

Operation disabled: Operation is stopped before switching to the SNOOZE mode.

f_{IH} : High-speed on-chip oscillator clock f_{IL} : Low-speed on-chip oscillator clock

f_X : X1 clock f_{EX} : External main system clock

f_{XT} : XT1 clock f_{EXS} : External subsystem clock

2. 20 to 64-pin products: p = 00; q = 0

80 to 128-pin products: p = 00, 20; q = 0, 2

(2) Timing diagram when the interrupt request signal is generated in the SNOOZE mode

Figure 18-5. When the Interrupt Request Signal is Generated in the SNOOZE Mode

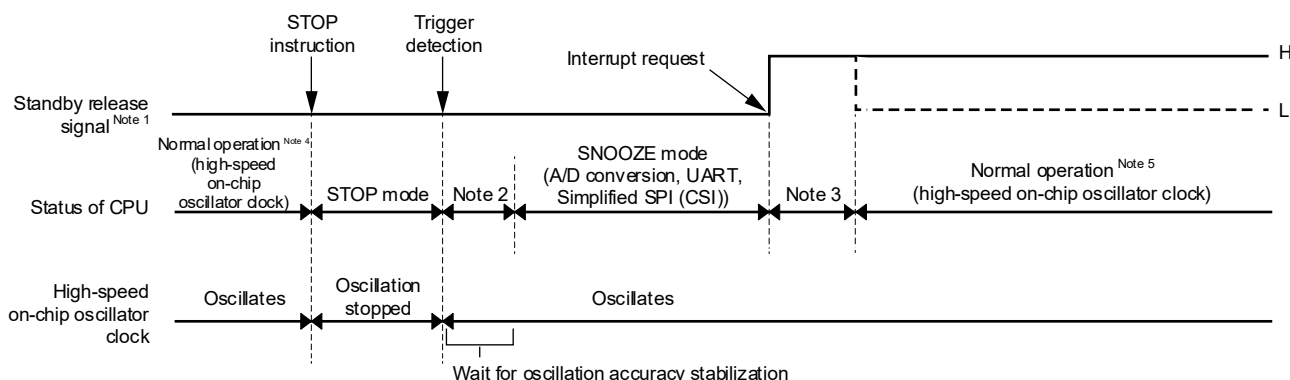

- Notes**
1. For details of the standby release signal, see **Figure 16-1**.
 2. Transition time from STOP mode to SNOOZE mode
 3. Transition time from SNOOZE mode to normal operation
 4. Enable the SNOOZE mode (AWC = 1 or SWC = 1) immediately before switching to the STOP mode.
 5. Be sure to release the SNOOZE mode (AWC = 0 or SWC = 0) immediately after return to the normal operation.

(3) Timing diagram when the interrupt request signal is not generated in the SNOOZE mode

Figure 18-6. When the Interrupt Request Signal is not Generated in the SNOOZE Mode

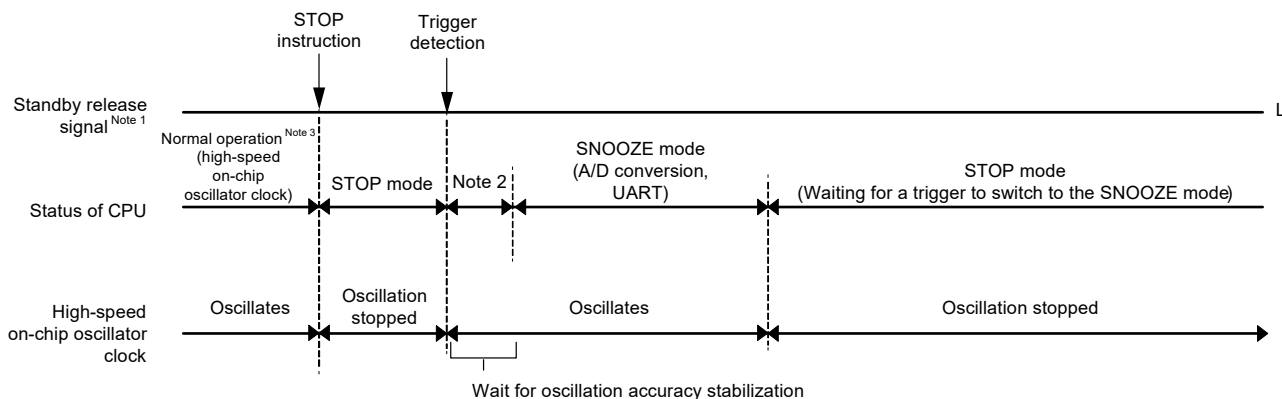

- Notes**
1. For details of the standby release signal, see **Figure 16-1**.
 2. Transition time from STOP mode to SNOOZE mode
 3. Enable the SNOOZE mode (AWC = 1 or SWC = 1) immediately before switching to the STOP mode.

Remark For details of the SNOOZE mode function, see **CHAPTER 11 A/D CONVERTER** and **CHAPTER 12 SERIAL ARRAY UNIT**.

CHAPTER 19 RESET FUNCTION

The following seven operations are available to generate a reset signal.

- (1) External reset input via $\overline{\text{RESET}}$ pin
- (2) Internal reset by watchdog timer program loop detection
- (3) Internal reset by comparison of supply voltage and detection voltage of power-on-reset (POR) circuit
- (4) Internal reset by comparison of supply voltage of the voltage detector (LVD) and detection voltage
- (5) Internal reset by execution of illegal instruction^{Note}
- (6) Internal reset by RAM parity error
- (7) Internal reset by illegal-memory access

External and internal resets start program execution from the address stored at 00000H and 00001H when the reset signal is generated.

A reset is effected when a low level is input to the $\overline{\text{RESET}}$ pin, the watchdog timer overflows, or by POR and LVD circuit voltage detection, execution of illegal instruction^{Note}, RAM parity error or illegal-memory access, and each item of hardware is set to the status shown in Table 19-1.

Note The illegal instruction is generated when instruction code FFH is executed.

Reset by the illegal instruction execution not issued by emulation with the in-circuit emulator or on-chip debug emulator.

Cautions 1. For an external reset, input a low level for 10 μs or more to the $\overline{\text{RESET}}$ pin.

To perform an external reset upon power application, input a low level to the $\overline{\text{RESET}}$ pin, turn power on, continue to input a low level to the pin for 10 μs or more within the operating voltage range shown in 29.4 or 30.4 AC Characteristics, and then input a high level to the pin.

2. During reset input, the X1 clock, XT1 clock, high-speed on-chip oscillator clock, and low-speed on-chip oscillator clock stop oscillating. External main system clock input and external subsystem clock input become invalid.

3. The port pins become the following state because each SFR and 2nd SFR are initialized after reset.

- P40: High-impedance during the external reset period or reset period by the POR. High level during other types of reset or after receiving a reset signal (connected to the internal pull-up resistor).
- P130: Low level during the reset period or after receiving a reset signal.
- Ports other than P40 and P130: High-impedance during the reset period or after receiving a reset signal.

Remark V_{POR} : POR power supply rise detection voltage

V_{LVD} : LVD detection voltage

Figure 19-1. Block Diagram of Reset Function

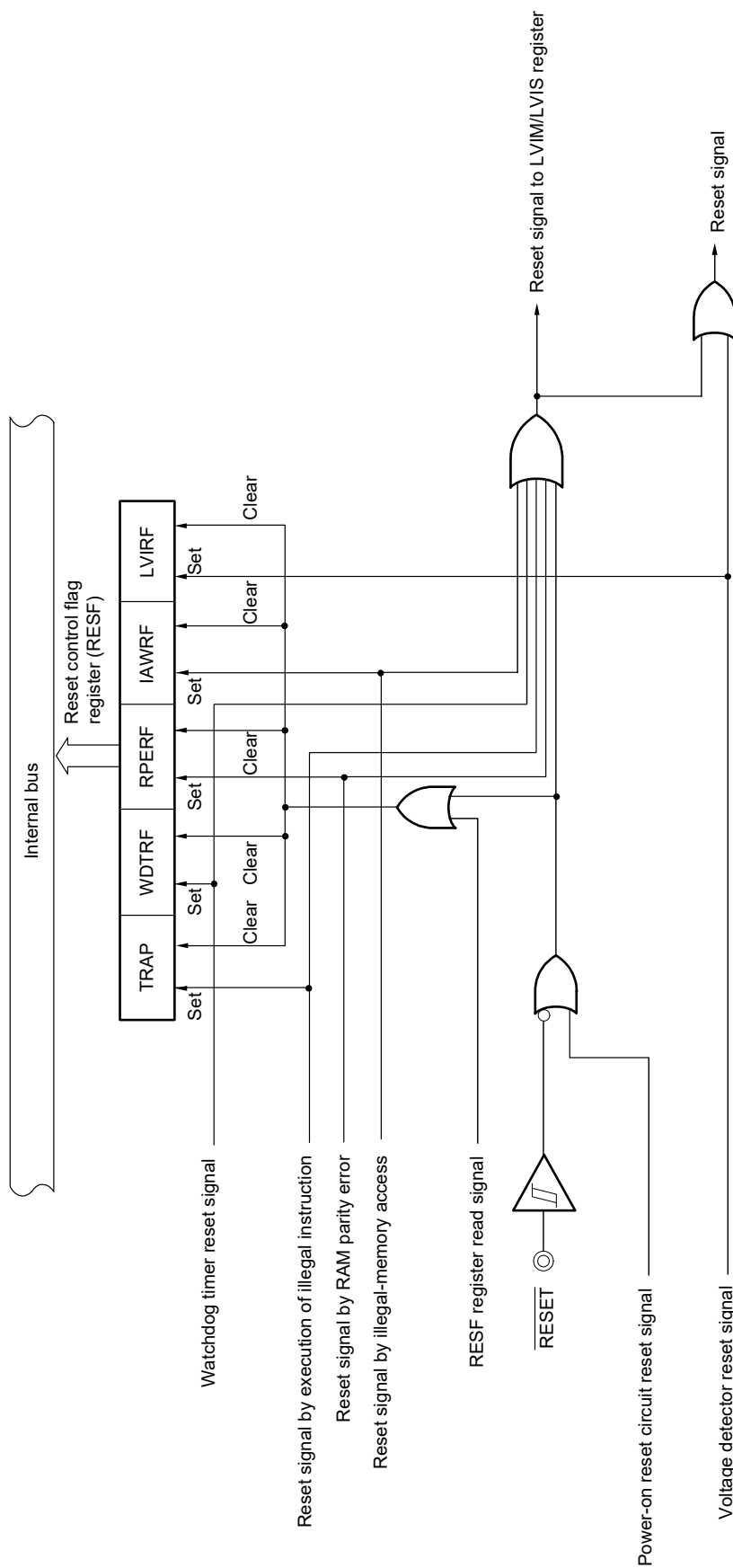

Caution An LVD circuit internal reset does not reset the LVD circuit.

- Remarks**
1. LVIM: Voltage detection register
 2. LVIS: Voltage detection level register

19.1 Timing of Reset Operation

This LSI is reset by input of the low level on the $\overline{\text{RESET}}$ pin and released from the reset state by input of the high level on the $\overline{\text{RESET}}$ pin. After reset processing, execution of the program with the high-speed on-chip oscillator clock as the operating clock starts.

Figure 19-2. Timing of Reset by $\overline{\text{RESET}}$ Input

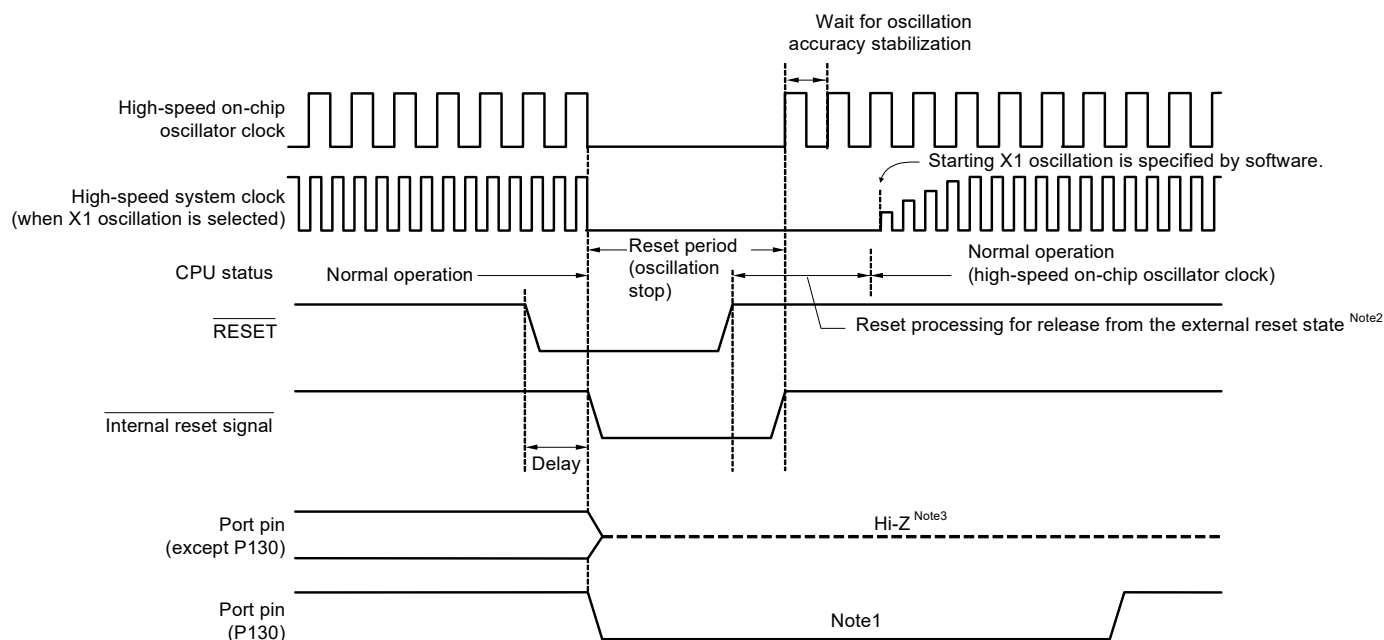

Release from the reset state is automatic in the case of a reset due to a watchdog timer overflow, execution of an illegal instruction, detection of a RAM parity error, or detection of illegal memory access. After reset processing, execution of the program with the high-speed on-chip oscillator clock as the operating clock starts.

Figure 19-3. Timing of Reset Due to Watchdog Timer Overflow, Execution of Illegal Instruction, Detection of RAM Parity Error, or Detection of Illegal Memory Access

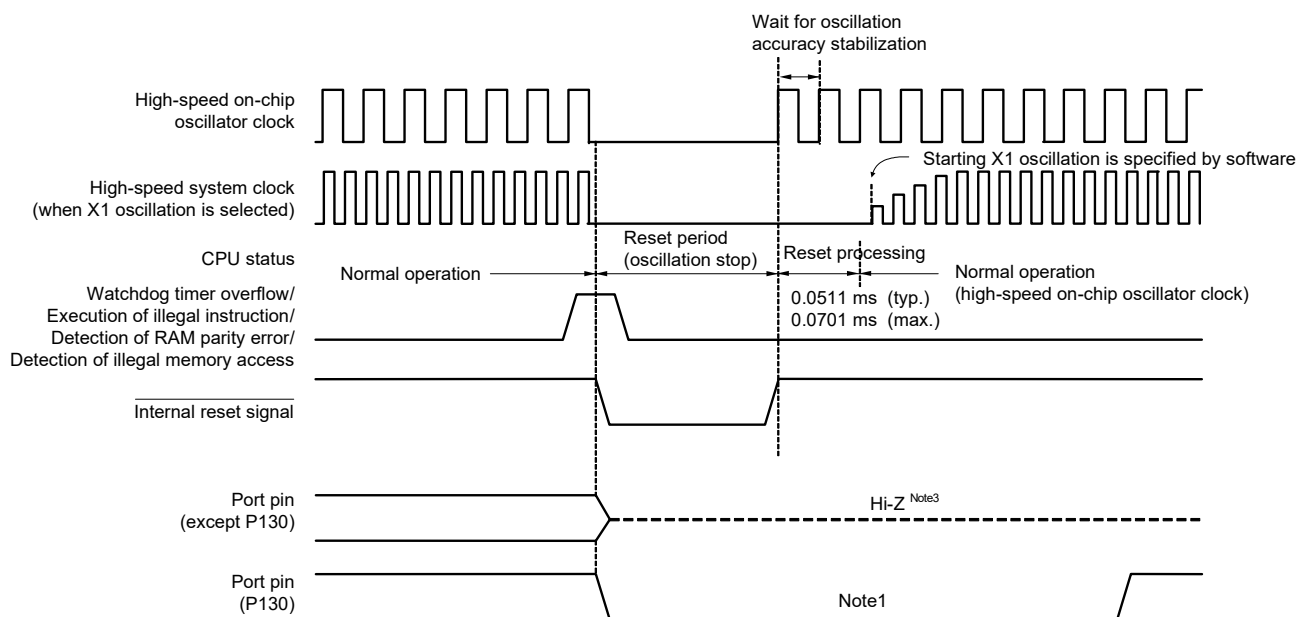

(Notes are listed on the next page.)

- Notes**
1. When P130 is set to high-level output before reset is effected, the output signal of P130 can be dummy-output as a reset signal to an external device, because P130 outputs a low level when reset is effected. To release a reset signal to an external device, set P130 to high-level output by software.
 2. Reset times (times for release from the external reset state)
After the first release of the POR: 0.672 ms (typ.), 0.832 ms (max.) when the LVD is in use.
0.399 ms (typ.), 0.519 ms (max.) when the LVD is off.
After the second release of the POR: 0.531 ms (typ.), 0.675 ms (max.) when the LVD is in use.
0.259 ms (typ.), 0.362 ms (max.) when the LVD is off.

After power is supplied, a voltage stabilization waiting time of about 0.99 ms (typ.) and up to 2.30 ms (max.) is required before reset processing starts after release of the external reset.
 3. The state of P40 is as follows.
 - High-impedance during the external reset period or reset period by the POR.
 - High level during other types of reset or after receiving a reset signal (connected to the internal pull-up resistor).

Reset by POR and LVD circuit supply voltage detection is automatically released when $V_{DD} \geq V_{POR}$ or $V_{DD} \geq V_{LVD}$ after the reset. After reset processing, execution of the program with the high-speed on-chip oscillator clock as the operating clock starts. For details, see **CHAPTER 20 POWER-ON-RESET CIRCUIT** or **CHAPTER 21 VOLTAGE DETECTOR**.

19.2 States of Operation During Reset Periods

Table 19-1 shows the states of operation during reset periods. Table 19-2 shows the states of the hardware after receiving a reset signal.

Table 19-1. States of Operation During Reset Period

Item	During Reset Period			
System clock	Clock supply to the CPU is stopped.			
Main system clock	f_{IH}	Operation stopped		
	f_X	Operation stopped (the X1 and X2 pins are input port mode)		
	f_{EX}	Clock input invalid (the pin is input port mode)		
Subsystem clock	f_{XT}	Operation stopped (the XT1 and XT2 pins are input port mode)		
	f_{EXS}	Clock input invalid (the pin is input port mode)		
f_{IL}	Operation stopped			
CPU	Operation stopped			
Code flash memory	Operation stopped			
Data flash memory	Operation stopped			
RAM	Operation stopped			
Port (latch)	High impedance ^{Note}			
Timer array unit	Operation stopped			
Real-time clock (RTC)				
12-bit interval timer				
Watchdog timer				
Clock output/buzzer output				
A/D converter				
Serial array unit (SAU)				
Serial interface (IICA)				
Multiplier & divider, multiply-accumulator				
DMA controller				
Power-on-reset function			Detection operation possible	
Voltage detection function			Operation is possible in the case of an LVD reset and stopped in the case of other types of reset.	
External interrupt			Operation stopped	
Key interrupt function				
CRC operation function	High-speed CRC			
	General-purpose CRC			
RAM parity error detection function				
RAM guard function				
SFR guard function				
Illegal-memory access detection function				

Note P40 and P130 become the following state.

- P40: High-impedance during the external reset period or reset period by the POR. High level during other types of reset (connected to the internal pull-up resistor).
- P130: Low level during the reset period

(Remark is listed on the next page.)

Remark f_H: High-speed on-chip oscillator clock
 f_X: X1 oscillation clock
 f_{EX}: External main system clock
 f_{XT}: XT1 oscillation clock
 f_{EXS}: External subsystem clock
 f_L: Low-speed on-chip oscillator clock

Table 19-2. State of Hardware After Receiving a Reset Signal

Hardware		After Reset Acknowledgment ^{Note}
Program counter (PC)		The contents of the reset vector table (00000H, 00001H) are set.
Stack pointer (SP)		Undefined
Program status word (PSW)		06H
RAM	Data memory	Undefined
	General-purpose registers	Undefined

Note During reset signal generation or oscillation stabilization time wait, only the PC contents among the hardware statuses become undefined. All other hardware statuses remain unchanged after reset.

Remark For the state of the special function register (SFR) after receiving a reset signal, see **3.1.4 Special function register (SFR) area** and **3.1.5 Extended special function register (2nd SFR: 2nd Special Function Register) area**.

19.3 Register for Confirming Reset Source

19.3.1 Reset Control Flag Register (RESF)

Many internal reset generation sources exist in the RL78 microcontroller. The reset control flag register (RESF) is used to store which source has generated the reset request.

The RESF register can be read by an 8-bit memory manipulation instruction.

RESET input, reset by power-on-reset (POR) circuit, and reading the RESF register clear TRAP, WDTRF, RPERF, IAWRF, and LVIRF flags.

Figure 19-4. Format of Reset Control Flag Register (RESF)

Address: FFFA8H After reset: Undefined ^{Note 1} R

Symbol	7	6	5	4	3	2	1	0
RESF	TRAP	0	0	WDTRF	0	RPERF	IAWRF	LVIRF

TRAP	Internal reset request by execution of illegal instruction ^{Note 2}
0	Internal reset request is not generated, or the RESF register is cleared.
1	Internal reset request is generated.

WDTRF	Internal reset request by watchdog timer (WDT)
0	Internal reset request is not generated, or the RESF register is cleared.
1	Internal reset request is generated.

RPERF	Internal reset request t by RAM parity
0	Internal reset request is not generated, or the RESF register is cleared.
1	Internal reset request is generated.

IAWRF	Internal reset request t by illegal-memory access
0	Internal reset request is not generated, or the RESF register is cleared.
1	Internal reset request is generated.

LVIRF	Internal reset request by voltage detector (LVD)
0	Internal reset request is not generated, or the RESF register is cleared.
1	Internal reset request is generated.

- Notes**
- The value after reset varies depending on the reset source. See **Table 19-3**.
 - The illegal instruction is generated when instruction code FFH is executed.
Reset by the illegal instruction execution not issued by emulation with the in-circuit emulator or on-chip debug emulator.

- Cautions**
- Do not read data by a 1-bit memory manipulation instruction.
 - When enabling RAM parity error resets (RPERDIS = 0), be sure to initialize the used RAM area at data access or the used RAM area + 10 bytes at execution of instruction from the RAM area.
Reset generation enables RAM parity error resets (RPERDIS = 0). For details, see 22.3.3 RAM parity error detection function.

The status of the RESF register when a reset request is generated is shown in Table 19-3.

Table 19-3. RESF Register Status When Reset Request Is Generated

Reset Source Flag	RESET Input	Reset by POR	Reset by Execution of Illegal Instruction	Reset by WDT	Reset by RAM parity error	Reset by illegal- memory access	Reset by LVD
TRAP bit	Cleared (0)	Cleared (0)	Set (1)	Held	Held	Held	Held
WDTRF bit			Held	Set (1)			
RPERF bit				Held	Set (1)		
IAWRF bit					Held	Set (1)	
LVIRF bit						Held	

The RESF register is automatically cleared when it is read by an 8-bit memory manipulation instruction. Figure 19-5 shows the procedure for checking a reset source.

Figure 19-5. Example of Procedure for Checking Reset Source

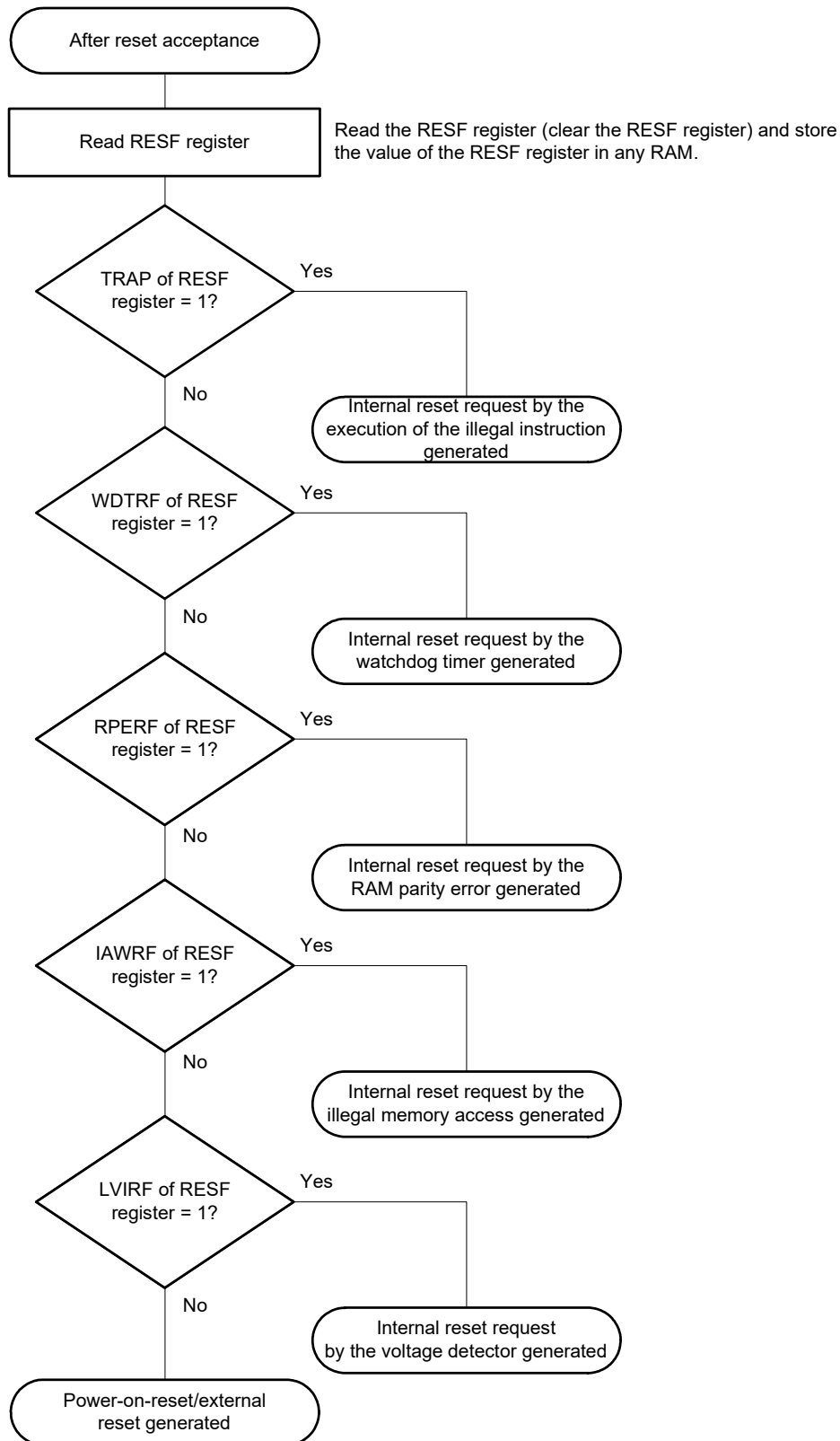

The flow described above is an example of the procedure for checking.

CHAPTER 20 POWER-ON-RESET CIRCUIT

20.1 Functions of Power-on-reset Circuit

The power-on-reset circuit (POR) has the following functions.

- Generates internal reset signal at power on.
The reset signal is released when the supply voltage (V_{DD}) exceeds the detection voltage (V_{POR}). Note that the reset state must be retained until the operating voltage becomes in the range defined in **29.4** or **30.4 AC Characteristics**. This is done by utilizing the voltage detection circuit or controlling the externally input reset signal.
- Compares supply voltage (V_{DD}) and detection voltage (V_{PDR}), generates internal reset signal when $V_{DD} < V_{PDR}$. Note that, after power is supplied, this LSI should be placed in the STOP mode, or in the reset state by utilizing the voltage detection circuit or externally input reset signal, before the operation voltage falls below the range defined in **29.4** or **30.4 AC Characteristics**. When restarting the operation, make sure that the operation voltage has returned within the range of operation.

Caution If an internal reset signal is generated in the power-on-reset circuit, the reset control flag register (RESF) is cleared.

- Remarks**
1. The RL78 microcontroller incorporates multiple hardware functions that generate an internal reset signal. A flag that indicates the reset source is located in the reset control flag register (RESF) for when an internal reset signal is generated by the watchdog timer (WDT), voltage-detector (LVD), illegal instruction execution, RAM parity error, or illegal-memory access. The RESF register is not cleared to 00H and the flag is set to 1 when an internal reset signal is generated by the watchdog timer (WDT), voltage-detector (LVD), illegal instruction execution, RAM parity error, or illegal-memory access.
For details of the RESF register, see **CHAPTER 19 RESET FUNCTION**.
 2. V_{POR} : POR power supply rise detection voltage
 V_{PDR} : POR power supply fall detection voltage
For details, see **29.6.3** or **30.6.3 POR circuit characteristics**.

20.2 Configuration of Power-on-reset Circuit

The block diagram of the power-on-reset circuit is shown in Figure 20-1.

Figure 20-1. Block Diagram of Power-on-reset Circuit

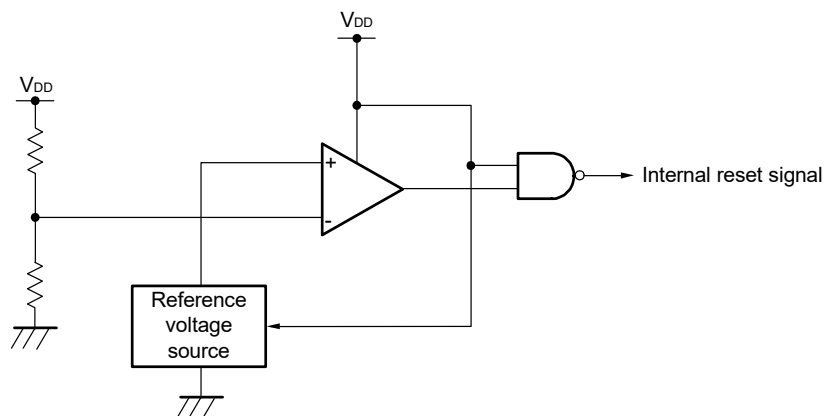

20.3 Operation of Power-on-reset Circuit

The timing of generation of the internal reset signal by the power-on-reset circuit and voltage detector is shown below.

Figure 20-2. Timing of Generation of Internal Reset Signal by Power-on-reset Circuit and Voltage Detector (1/3)

(1) When the externally input reset signal on the $\overline{\text{RESET}}$ pin is used

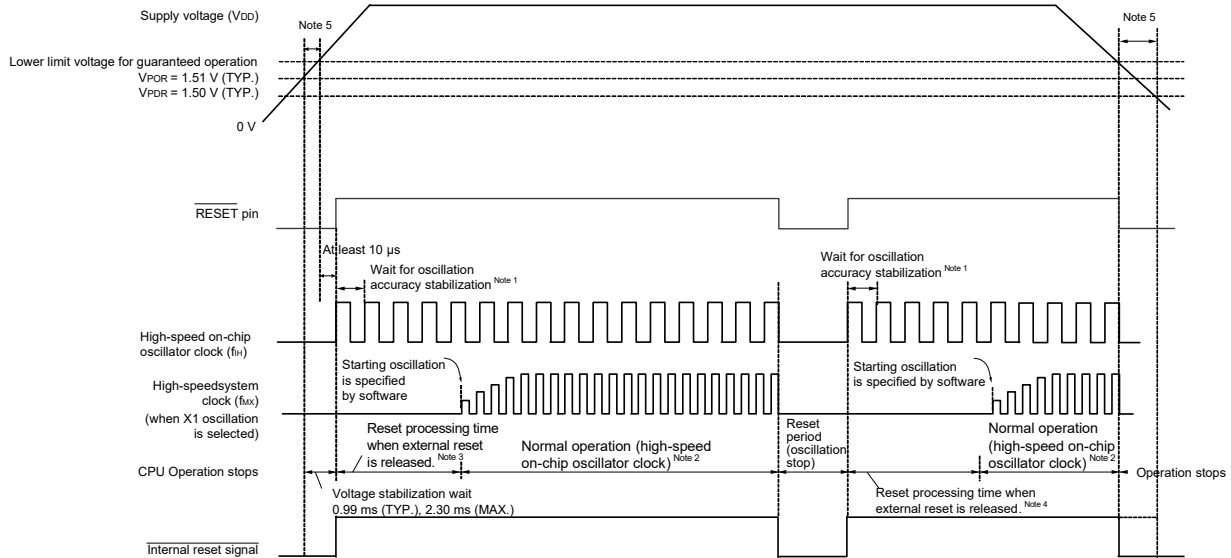

- Notes**
- The internal reset processing time includes the oscillation accuracy stabilization time of the high-speed on-chip oscillator clock.
 - The high-speed on-chip oscillator clock and a high-speed system clock or subsystem clock can be selected as the CPU clock. To use the X1 clock, use the oscillation stabilization time counter status register (OSTC) to confirm the lapse of the oscillation stabilization time. To use the XT1 clock, use the timer function for confirmation of the lapse of the stabilization time.
 - The time until normal operation starts includes the following reset processing time when the external reset is released (release from the first external reset following release from the POR state) after the $\overline{\text{RESET}}$ signal is driven high (1) as well as the voltage stabilization wait time after V_{POR} (1.51 V, typ.) is reached.
 With the LVD circuit in use: 0.672 ms (typ.), 0.832 ms (max.)
 With the LVD circuit not in use: 0.399 ms (typ.), 0.519 ms (max.)
 - The reset processing times in the case of the second or subsequent external reset following release from the POR state are listed below.
 With the LVD circuit in use: 0.531 ms (typ.), 0.675 ms (max.)
 With the LVD circuit not in use: 0.259 ms (typ.), 0.362 ms (max.)
 - After power is supplied, the reset state must be retained until the operating voltage becomes in the range defined in **29.4** or **30.4 AC Characteristics**. This is done by controlling the externally input reset signal. After power supply is turned off, this LSI should be placed in the STOP mode, or in the reset state by utilizing the voltage detection circuit or externally input reset signal, before the voltage falls below the operating range. When restarting the operation, make sure that the operation voltage has returned within the range of operation.

Caution For power-on reset, be sure to use the externally input reset signal on the $\overline{\text{RESET}}$ pin when the LVD is off. For details, see CHAPTER 21 VOLTAGE DETECTOR.

Remark V_{POR} : POR power supply rise detection voltage
 V_{PDR} : POR power supply fall detection voltage

Figure 20-2. Timing of Generation of Internal Reset Signal by Power-on-reset Circuit and Voltage Detector (2/3)

(2) LVD interrupt & reset mode (option byte 000C1: LVIMDS1, LVIMDS0 = 1, 0)

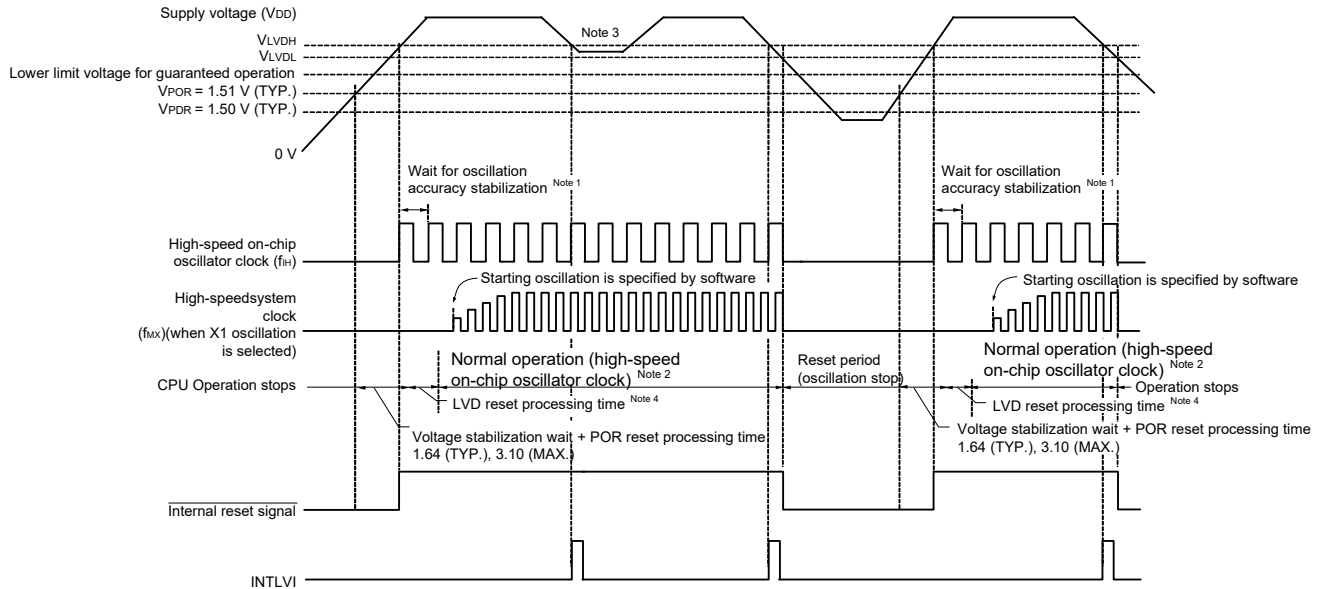

- Notes**
1. The internal reset processing time includes the oscillation accuracy stabilization time of the high-speed on-chip oscillator clock.
 2. The high-speed on-chip oscillator clock and a high-speed system clock or subsystem clock can be selected as the CPU clock. To use the X1 clock, use the oscillation stabilization time counter status register (OSTC) to confirm the lapse of the oscillation stabilization time. To use the XT1 clock, use the timer function for confirmation of the lapse of the stabilization time.
 3. After the interrupt request signal (INTLVI) is generated, the LVILV and LVIMD bits of the voltage detection level register (LVIS) are automatically set to 1. After INTLVI is generated, appropriate settings should be made according to **Figure 21-8 Processing Procedure After an Interrupt Is Generated** and **Figure 21-9 Initial Setting of Interrupt and Reset Mode**, taking into consideration that the supply voltage might return to the high voltage detection level (VLVDH) or higher without falling below the low voltage detection level (VLVDL).
 4. The time until normal operation starts includes the following LVD reset processing time after the LVD detection level (VLVDH) is reached as well as the voltage stabilization wait + POR reset processing time after the VPOr (1.51 V, typ.) is reached.
LVD reset processing time: 0 ms to 0.0701 ms (max.)

Remark VLVDH, VLVDL: LVD detection voltage
VPOr: POR power supply rise detection voltage
VPOr: POR power supply fall detection voltage

Figure 20-2. Timing of Generation of Internal Reset Signal by Power-on-reset Circuit and Voltage Detector (3/3)

(3) LVD reset mode (option byte 000C1H: LVIMDS1 = 1, LVIMDS0 = 1)

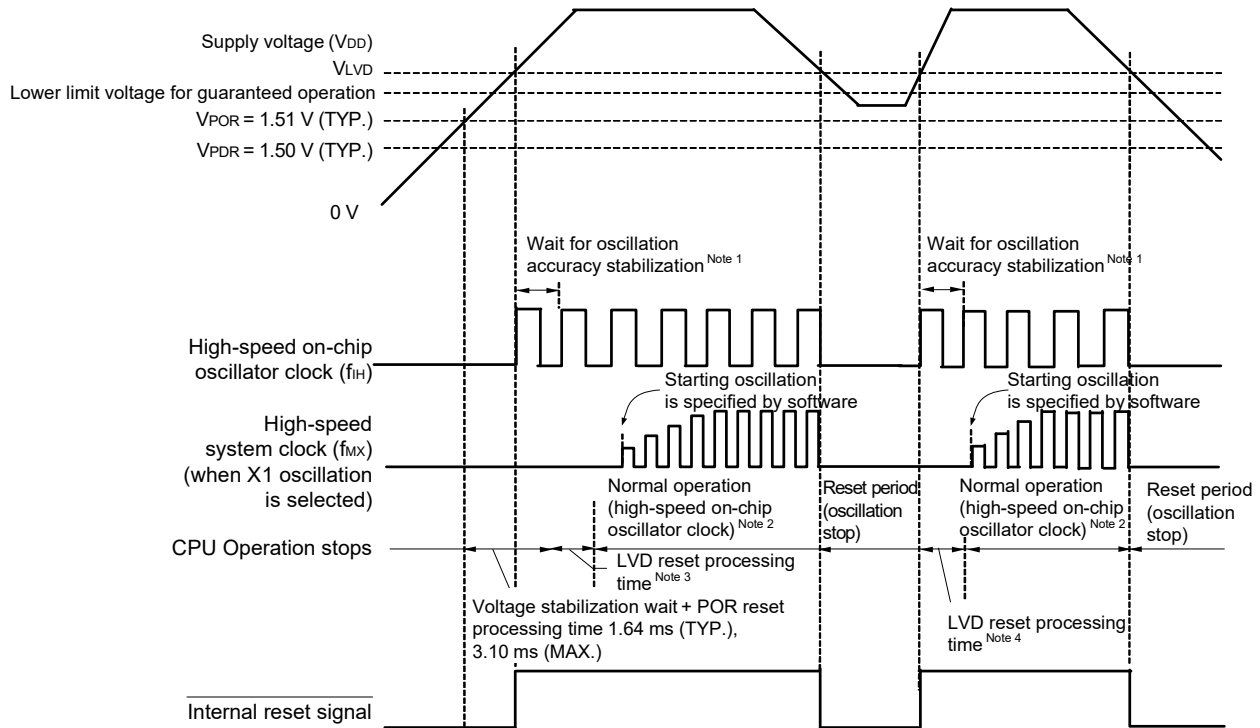

- Notes**
1. The internal reset processing time includes the oscillation accuracy stabilization time of the high-speed on-chip oscillator clock.
 2. The high-speed on-chip oscillator clock and a high-speed system clock or subsystem clock can be selected as the CPU clock. To use the X1 clock, use the oscillation stabilization time counter status register (OSTC) to confirm the lapse of the oscillation stabilization time. To use the XT1 clock, use the timer function for confirmation of the lapse of the stabilization time.
 3. The time until normal operation starts includes the following LVD reset processing time after the LVD detection level (V_{LVD}) is reached as well as the voltage stabilization wait + POR reset processing time after the V_{POR} (1.51 V, typ.) is reached.
LVD reset processing time: 0 ms to 0.0701 ms (max.)
 4. When the power supply voltage is below the lower limit for operation and the power supply voltage is then restored after an internal reset is generated only by the voltage detector (LVD), the following LVD reset processing time is required after the LVD detection level (V_{LVD}) is reached.
LVD reset processing time: 0.0511 ms (typ.), 0.0701 ms (max.)

- Remarks**
1. V_{LVDH} , V_{LVDL} : LVD detection voltage
 V_{POR} : POR power supply rise detection voltage
 V_{PDR} : POR power supply fall detection voltage
 2. When the LVD interrupt mode is selected (option byte 000C1H: LVIMD1 = 0, LVIMD0 = 1), the time until normal operation starts after power is turned on is the same as the time specified in Note 3 of Figure 20-2 (3).

CHAPTER 21 VOLTAGE DETECTOR

21.1 Functions of Voltage Detector

The operation mode and detection voltages (V_{LVDH} , V_{LVDL} , V_{LVD}) for the voltage detector is set by using the option byte (000C1H).

The voltage detector (LVD) has the following functions.

- The LVD circuit compares the supply voltage (V_{DD}) with the detection voltage (V_{LVDH} , V_{LVDL} , V_{LVD}), and generates an internal reset or internal interrupt signal.
- The detection level for the power supply detection voltage (V_{LVDH} , V_{LVDL} , V_{LVD}) can be selected by using the option byte as one of 14 levels (For details, see **CHAPTER 24 OPTION BYTE**).
- Operable in STOP mode.
- After power is supplied, the reset state must be retained until the operating voltage becomes in the range defined in **29.4** or **30.4 AC Characteristics**. This is done by utilizing the voltage detector circuit or controlling the externally input reset signal. After the power supply is turned off, this LSI should be placed in the STOP mode, or placed in the reset state by utilizing the voltage detector or controlling the externally input reset signal before the voltage falls below the operating range. The range of operating voltage varies with the setting of the user option byte (000C2H or 010C2H).

(a) Interrupt & reset mode (option byte LVIMDS1, LVIMDS0 = 1, 0)

The two detection voltages (V_{LVDH} , V_{LVDL}) are selected by the option byte 000C1H. The high-voltage detection level (V_{LVDH}) is used for releasing resets and generating interrupts. The low-voltage detection level (V_{LVDL}) is used for generating resets.

(b) Reset mode (option byte LVIMDS1, LVIMDS0 = 1, 1)

The detection voltage (V_{LVD}) selected by the option byte 000C1H is used for generating/releasing resets.

(c) Interrupt mode (option byte LVIMDS1, LVIMDS0 = 0, 1)

The detection voltage (V_{LVD}) selected by the option byte 000C1H is used for releasing resets/generating interrupts.

The reset and internal interrupt signals are generated in each mode as follows.

Interrupt & reset mode (LVIMDS1, LVIMDS0 = 1, 0)	Reset mode (LVIMDS1, LVIMDS0 = 1, 1)	Interrupt mode (LVIMDS1, LVIMDS0 = 0, 1)
Generates an interrupt request signal by detecting $V_{DD} < V_{LVDH}$ when the operating voltage falls, and an internal reset by detecting $V_{DD} < V_{LVDL}$. Releases an internal reset by detecting $V_{DD} \geq V_{LVDH}$.	Releases an internal reset by detecting $V_{DD} \geq V_{LVD}$. Generates an internal reset by detecting $V_{DD} < V_{LVD}$.	Retains the state of an internal reset by the LVD immediately after a reset until $V_{DD} \geq V_{LVD}$. Releases the LVD internal reset by detecting $V_{DD} \geq V_{LVD}$. Generates an interrupt request signal (INTLVI) by detecting $V_{DD} < V_{LVD}$ or $V_{DD} \geq V_{LVD}$ after the LVD internal reset is released.

While the voltage detector is operating, whether the supply voltage is more than or less than the detection level can be checked by reading the voltage detection flag (LVIF: bit 0 of the voltage detection register (LVIM)).

Bit 0 (LVIRF) of the reset control flag register (RESF) is set to 1 if reset occurs. For details of the RESF register, see **CHAPTER 19 RESET FUNCTION**.

21.2 Configuration of Voltage Detector

The block diagram of the voltage detector is shown in Figure 21-1.

Figure 21-1. Block Diagram of Voltage Detector

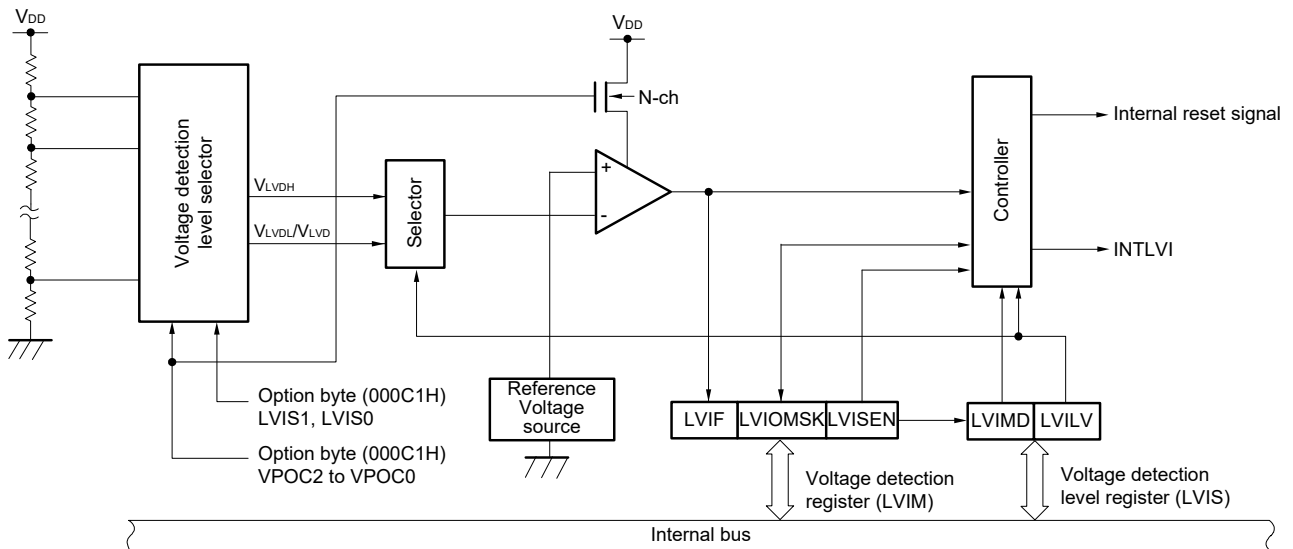

21.3 Registers Controlling Voltage Detector

The voltage detector is controlled by the following registers.

- Voltage detection register (LVIM)
- Voltage detection level register (LVIS)

21.3.1 Voltage detection register (LVIM)

This register is used to specify whether to enable or disable rewriting the voltage detection level register (LVIS), as well as to check the LVD output mask status.

This register can be set by a 1-bit or 8-bit memory manipulation instruction.

Reset signal generation clears this register to 00H.

Figure 21-2. Format of Voltage Detection Register (LVIM)

Address: FFFA9H After reset: 00H ^{Note 1} R/W ^{Note 2}

Symbol	<7>	6	5	4	3	2	<1>	<0>
LVIM	LVISEN ^{Note 3}	0	0	0	0	0	LVIOMSK	LVIF

LVISEN ^{Note 3}	Specification of whether to enable or disable rewriting the voltage detection level register (LVIS)
0	Disabling of rewriting the LVIS register (LVIOMSK = 0 (Mask of LVD output is invalid))
1	Enabling of rewriting the LVIS register ^{Note 3} (LVIOMSK = 1 (Mask of LVD output is valid))

LVIOMSK	Mask status flag of LVD output
0	Mask of LVD output is invalid
1	Mask of LVD output is valid ^{Note 4}

LVIF	Voltage detection flag
0	Supply voltage (V _{DD}) ≥ detection voltage (V _{LVD}), or when LVD is off
1	Supply voltage (V _{DD}) < detection voltage (V _{LVD})

- Notes**
1. The reset value changes depending on the reset source.
If the LVIS register is reset by LVD, it is not reset but holds the current value. In other reset, LVISEN is cleared to 0.
 2. Bits 0 and 1 are read-only.
 3. LVISEN and LVIOMSK can only be set in the interrupt & reset mode (option byte LVIMDS1, LVIMDS0 = 1, 0). Do not change the initial value in other modes.
 4. LVIOMSK bit is only automatically set to “1” when the interrupt & reset mode is selected (option byte LVIMDS1, LVIMDS0 = 1, 0) and reset or interrupt by LVD is masked.
 - Period during LVISEN = 1
 - Waiting period from the time when LVD interrupt is generated until LVD detection voltage becomes stable
 - Waiting period from the time when the value of LVILV bit changes until LVD detection voltage becomes stable

21.3.2 Voltage detection level register (LVIS)

This register selects the voltage detection level.

This register can be set by a 1-bit or 8-bit memory manipulation instruction.

Reset signal generation input sets this register to 00H/01H/81H ^{Note1}.

Figure 21-3. Format of Voltage Detection Level Select Register (LVIS)

Address: FFFAAH After reset: 00H/01H/81H ^{Note 1} R/W

Symbol	<7>	6	5	4	3	2	1	<0>
LVIS	LVIMD	0	0	0	0	0	0	LVILV

LVIMD ^{Note 2}	Operation mode of voltage detection
0	Interrupt mode
1	Reset mode

LVILV ^{Note 2}	LVD detection level
0	High-voltage detection level (V _{LVDH})
1	Low-voltage detection level (V _{LVDL} or V _{LVDL})

- Notes 1.** The reset value changes depending on the reset source and the setting of the option byte. This register is not cleared (00H) by LVD reset. The generation of reset signal other than an LVD reset sets as follows.
- When option byte LVIMDS1, LVIMDS0 = 1, 0: 00H
 - When option byte LVIMDS1, LVIMDS0 = 1, 1: 81H
 - When option byte LVIMDS1, LVIMDS0 = 0, 1: 01H
- 2.** Writing “0” can only be allowed in the interrupt & reset mode (option byte LVIMDS1, LVIMDS0 = 1, 0). Do not set LVIMD and LVILV in other cases. The value is switched automatically when reset or interrupt is generated in the interrupt & reset mode.

- Cautions 1.** Rewrite the value of the LVIS register according to Figures 21-8 and 21-9.
- 2.** Specify the LVD operation mode and detection voltage (V_{LVDH}, V_{LVDL}, V_{LVD}) of each mode by using the option byte 000C1H. Figure 21-4 shows the format of the user option byte (000C1H/010C1H). For details about the option byte, see CHAPTER 24 OPTION BYTE.

Figure 21-4. Format of User Option Byte (000C1H/010C1H) (1/2)

Address: 000C1H/010C1H^{Note}

7	6	5	4	3	2	1	0
VPOC2	VPOC1	VPOC0	1	LVIS1	LVIS0	LVIMDS1	LVIMDS0

• LVD setting (interrupt & reset mode)

Detection voltage			Option byte setting value						
V _{LV_{VDH}}		V _{LV_{VDL}}	VPOC2	VPOC1	VPOC0	LVIS1	LVIS0	Mode setting	
Rising edge	Falling edge	Falling edge						LVIMDS1	LVIMDS0
1.77 V	1.73 V	1.63 V	0	0	0	1	0	1	0
1.88 V	1.84 V					0	1		
2.92 V	2.86 V					0	0		
1.98 V	1.94 V	1.84 V		0	1	1	0		
2.09 V	2.04 V			0	1				
3.13 V	3.06 V			0	0				
2.61 V	2.55 V	2.45 V		1	0	1	0		
2.71 V	2.65 V			0	1				
3.75 V	3.67 V			0	0				
2.92 V	2.86 V	2.75 V		1	1	1	0		
3.02 V	2.96 V		0	1					
4.06 V	3.98 V		0	0					
-			Setting of values other than above is prohibited.						

• LVD setting (reset mode)

Detection voltage		Option byte setting value						
V _{LV_D}		VPOC2	VPOC1	VPOC0	LVIS1	LVIS0	Mode setting	
Rising edge	Falling edge						LVIMDS1	LVIMDS0
1.67 V	1.63 V	0	0	0	1	1	1	1
1.77 V	1.73 V		0	0	1	0		
1.88 V	1.84 V		0	1	1	1		
1.98 V	1.94 V		0	1	1	0		
2.09 V	2.04 V		0	1	0	1		
2.50 V	2.45 V		1	0	1	1		
2.61 V	2.55 V		1	0	1	0		
2.71 V	2.65 V		1	0	0	1		
2.81 V	2.75 V		1	1	1	1		
2.92 V	2.86 V		1	1	1	0		
3.02 V	2.96 V		1	1	0	1		
3.13 V	3.06 V		0	1	0	0		
3.75 V	3.67 V		1	0	0	0		
4.06 V	3.98 V		1	1	0	0		
-			Setting of values other than above is prohibited.					

Note Set the same value as 000C1H to 010C1H when the boot swap operation is used because 000C1H is replaced by 010C1H.

Remarks 1. For details on the LVD circuit, see **CHAPTER 21 VOLTAGE DETECTOR**.

2. The detection voltage is a TYP. value. For details, see **29.6.4** or **30.6.4 LVD circuit characteristics**.

(Cautions are listed on the next page.)

Figure 21-4. Format of User Option Byte (000C1H/010C1H) (2/2)

Address: 000C1H/010C1H^{Note}



• LVD setting (interrupt mode)

Detection voltage		Option byte setting value						
V _{LVD}		VPOC2	VPOC1	VPOC0	LVIS1	LVIS0	Mode setting	
Rising edge	Falling edge						LVIMDS1	LVIMDS0
1.67 V	1.63 V	0	0	0	1	1	0	1
1.77 V	1.73 V		0	0	1	0		
1.88 V	1.84 V		0	1	1	1		
1.98 V	1.94 V		0	1	1	0		
2.09 V	2.04 V		0	1	0	1		
2.50 V	2.45 V		1	0	1	1		
2.61 V	2.55 V		1	0	1	0		
2.71 V	2.65 V		1	0	0	1		
2.81 V	2.75 V		1	1	1	1		
2.92 V	2.86 V		1	1	1	0		
3.02 V	2.96 V		1	1	0	1		
3.13 V	3.06 V		0	1	0	0		
3.75 V	3.67 V		1	0	0	0		
4.06 V	3.98 V		1	1	0	0		
-		Setting of values other than above is prohibited.						

• LVD off (use of external reset input via $\overline{\text{RESET}}$ pin)

Detection voltage		Option byte setting value						
V _{LVD}		VPOC2	VPOC1	VPOC0	LVIS1	LVIS0	Mode setting	
Rising edge	Falling edge						LVIMDS1	LVIMDS0
-	-	1	x	x	x	x	x	1
-		Setting of values other than above is prohibited.						

Note Set the same value as 000C1H to 010C1H when the boot swap operation is used because 000C1H is replaced by 010C1H.

Cautions 1. Set bit 4 to 1.

2. After power is supplied, the reset state must be retained until the operating voltage becomes in the range defined in 29.4 or 30.4 AC Characteristics. This is done by utilizing the voltage detection circuit or controlling the externally input reset signal. After the power supply is turned off, this LSI should be placed in the STOP mode, or placed in the reset state by utilizing the voltage detection circuit or controlling the externally input reset signal, before the voltage falls below the operating range. The range of operating voltage varies with the setting of the user option byte (000C2H or 010C2H).

Remarks 1. x: don't care

2. For details on the LVD circuit, see CHAPTER 21 VOLTAGE DETECTOR.
3. The detection voltage is a TYP. value. For details, see 29.6.4 or 30.6.4 LVD circuit characteristics.

21.4 Operation of Voltage Detector

21.4.1 When used as reset mode

Specify the operation mode (the reset mode (LVIMDS1, LVIMDS0 = 1, 1)) and the detection voltage (V_{LVD}) by using the option byte 000C1H.

The operation is started in the following initial setting state when the reset mode is set.

- Bit 7 (LVISEN) of the voltage detection register (LVIM) is set to 0 (disable rewriting of voltage detection level register (LVIS))
- The initial value of the voltage detection level select register (LVIS) is set to 81H.
Bit 7 (LVIMD) is 1 (reset mode).
Bit 0 (LVILV) is 1 (low-voltage detection level: V_{LVD}).
- Operation in LVD reset mode
In the reset mode (option byte LVIMDS1, LVIMDS0 = 1, 1), the state of an internal reset by LVD is retained until the supply voltage (V_{DD}) exceeds the voltage detection level (V_{LVD}) after power is supplied. The internal reset is released when the supply voltage (V_{DD}) exceeds the voltage detection level (V_{LVD}).
At the fall of the operating voltage, an internal reset by LVD is generated when the supply voltage (V_{DD}) falls below the voltage detection level (V_{LVD}).

Figure 21-5 shows the timing of the internal reset signal generated in the LVD reset mode.

**Figure 21-5. Timing of Voltage Detector Internal Reset Signal Generation
(Option Byte LVIMDS1, LVIMDS0 = 1, 1)**

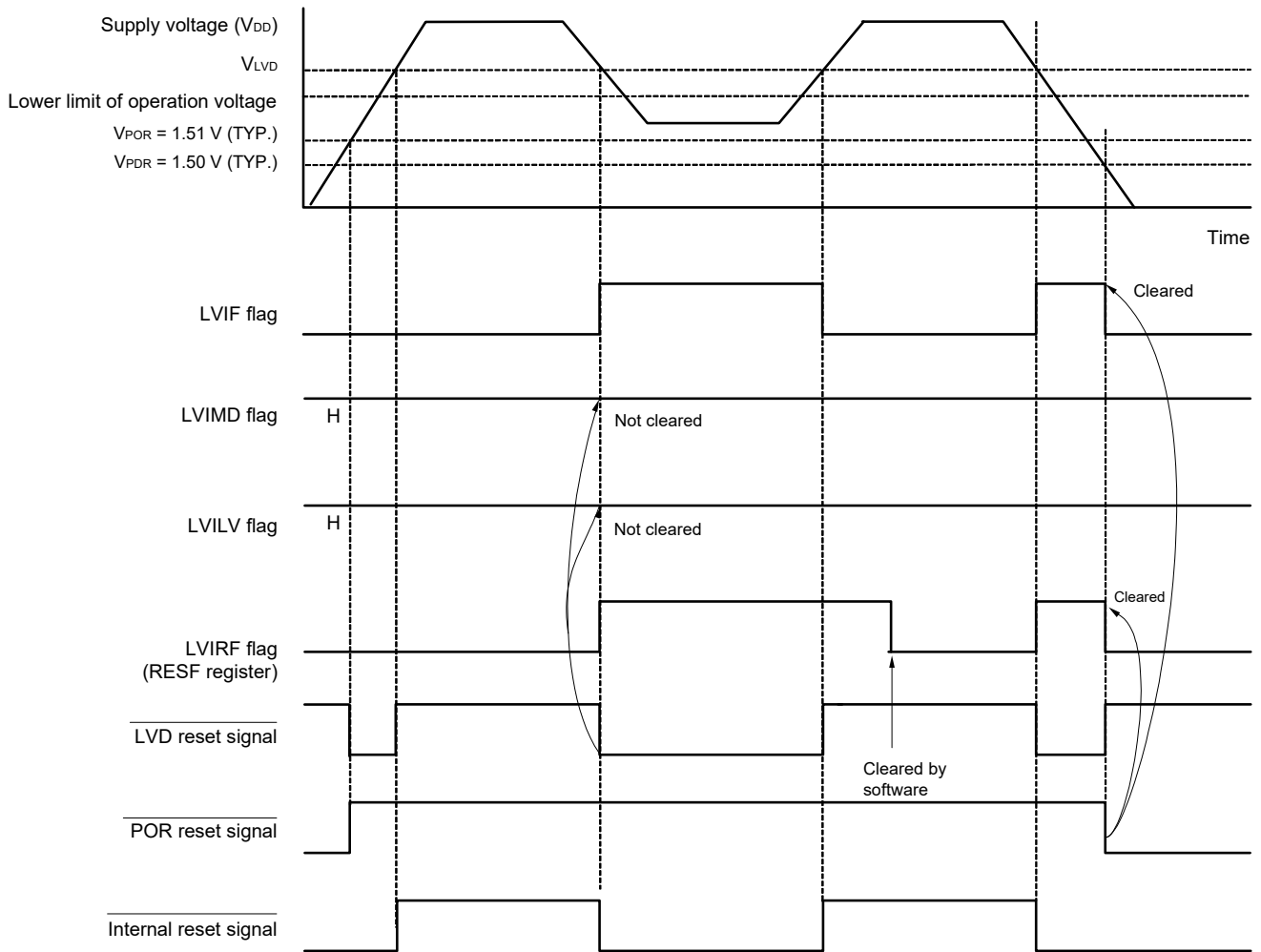

Remark V_{POR} : POR power supply rise detection voltage
 V_{PDR} : POR power supply fall detection voltage

21.4.2 When used as interrupt mode

Specify the operation mode (the interrupt mode (LVIMDS1, LVIMDS0 = 0, 1)) and the detection voltage (V_{LVD}) by using the option byte 000C1H.

The operation is started in the following initial setting state when the interrupt mode is set.

- Bit 7 (LVISEN) of the voltage detection register (LVIM) is set to 0 (disable rewriting of voltage detection level register (LVIS))
- The initial value of the voltage detection level select register (LVIS) is set to 01H.
Bit 7 (LVIMD) is 0 (interrupt mode).
Bit 0 (LVILV) is 1 (low-voltage detection level: V_{LVD}).
- Operation in LVD interrupt mode
In the interrupt mode (option byte LVIMDS1, LVIMDS0 = 0, 1), the state of an internal reset by LVD is retained immediately after a reset until the supply voltage (V_{DD}) exceeds the voltage detection level (V_{LVD}). The internal reset is released when the supply voltage (V_{DD}) exceeds the voltage detection level (V_{LVD}).
After the LVD internal reset is released, an interrupt request signal (INTLVI) by the LVD is generated when the supply voltage (V_{DD}) exceeds the voltage detection level (V_{LVD}).
When the voltage falls, this LSI should be placed in the STOP mode, or placed in the reset state by controlling the externally input reset signal, before the voltage falls below the operating voltage range defined in **29.4** or **30.4 AC Characteristics**. When restarting the operation, make sure that the operation voltage has returned within the range of operation.

Figure 21-6 shows the timing of the interrupt request signal generated in the LVD interrupt mode.

**Figure 21-6. Timing of Voltage Detector Internal Interrupt Signal Generation
(Option Byte LVIMDS1, LVIMDS0 = 0, 1)**

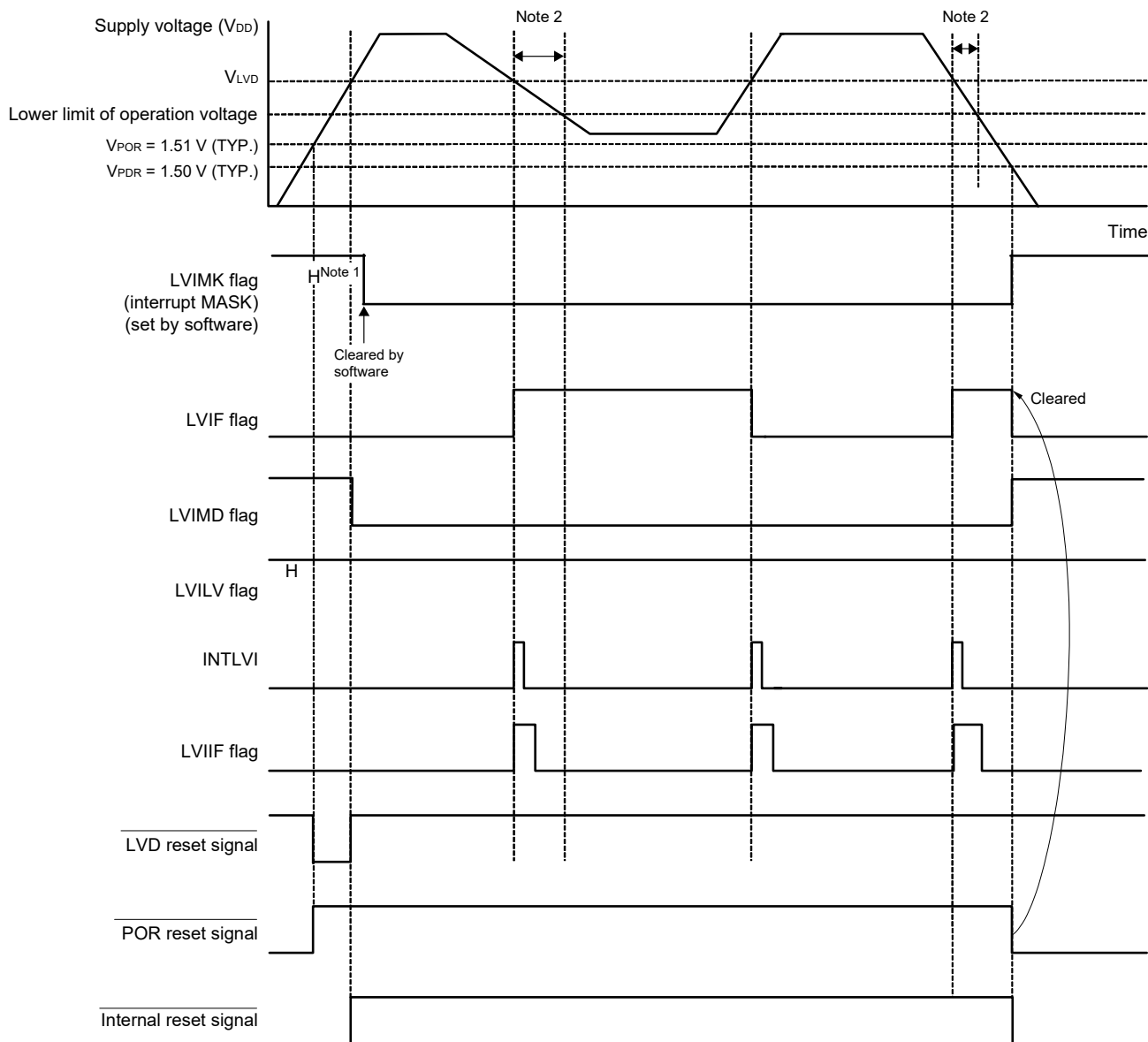

- Notes**
1. The LVIMK flag is set to "1" by reset signal generation.
 2. When the voltage falls, this LSI should be placed in the STOP mode, or placed in the reset state by controlling the externally input reset signal, before the voltage falls below the operating voltage range defined in **29.4** or **30.4 AC characteristics**. When restarting the operation, make sure that the operation voltage has returned within the range of operation.

Remark V_{POr}: POR power supply rise detection voltage
V_{PDR}: POR power supply fall detection voltage

21.4.3 When used as interrupt & reset mode

Specify the operation mode (the interrupt & reset (LVIMDS1, LVIMDS0 = 1, 0)) and the detection voltage (V_{LVDH} , V_{LVDL}) by using the option byte 000C1H.

The operation is started in the following initial setting state when the interrupt & reset mode is set.

- Bit 7 (LVISEN) of the voltage detection register (LVIM) is set to 0 (disable rewriting of voltage detection level register (LVIS))
- The initial value of the voltage detection level select register (LVIS) is set to 00H.
Bit 7 (LVIMD) is 0 (interrupt mode).
Bit 0 (LVILV) is 0 (high-voltage detection level: V_{LVDH}).
- Operation in LVD interrupt & reset mode
In the interrupt & reset mode (option byte LVIMDS1, LVIMDS0 = 1, 0), the state of an internal reset by LVD is retained until the supply voltage (V_{DD}) exceeds the high-voltage detection level (V_{LVDH}) after power is supplied. The internal reset is released when the supply voltage (V_{DD}) exceeds the high-voltage detection level (V_{LVDH}). An interrupt request signal by LVD (INTLVI) is generated and arbitrary save processing is performed when the supply voltage (V_{DD}) falls below the high-voltage detection level (V_{LVDH}). After that, an internal reset by LVD is generated when the supply voltage (V_{DD}) falls below the low-voltage detection level (V_{LVDL}). After INTLVD is generated, an interrupt request signal is not generated even if the supply voltage becomes equal to or higher than the high-voltage detection voltage (V_{LVDH}) without falling below the low-voltage detection voltage (V_{LVDL}). To use the LVD reset & interrupt mode, perform the processing according to **Figure 21-8 Processing Procedure After an Interrupt Is Generated** and **Figure 21-9 Initial Setting of Interrupt and Reset Mode**.

Figure 21-7 shows the timing of the internal reset signal and interrupt signal generated in the LVD interrupt & reset mode.

Figure 21-7. Timing of Voltage Detector Reset Signal and Interrupt Signal Generation (Option Byte LVIMDS1, LVIMDS0 = 1, 0) (1/2)

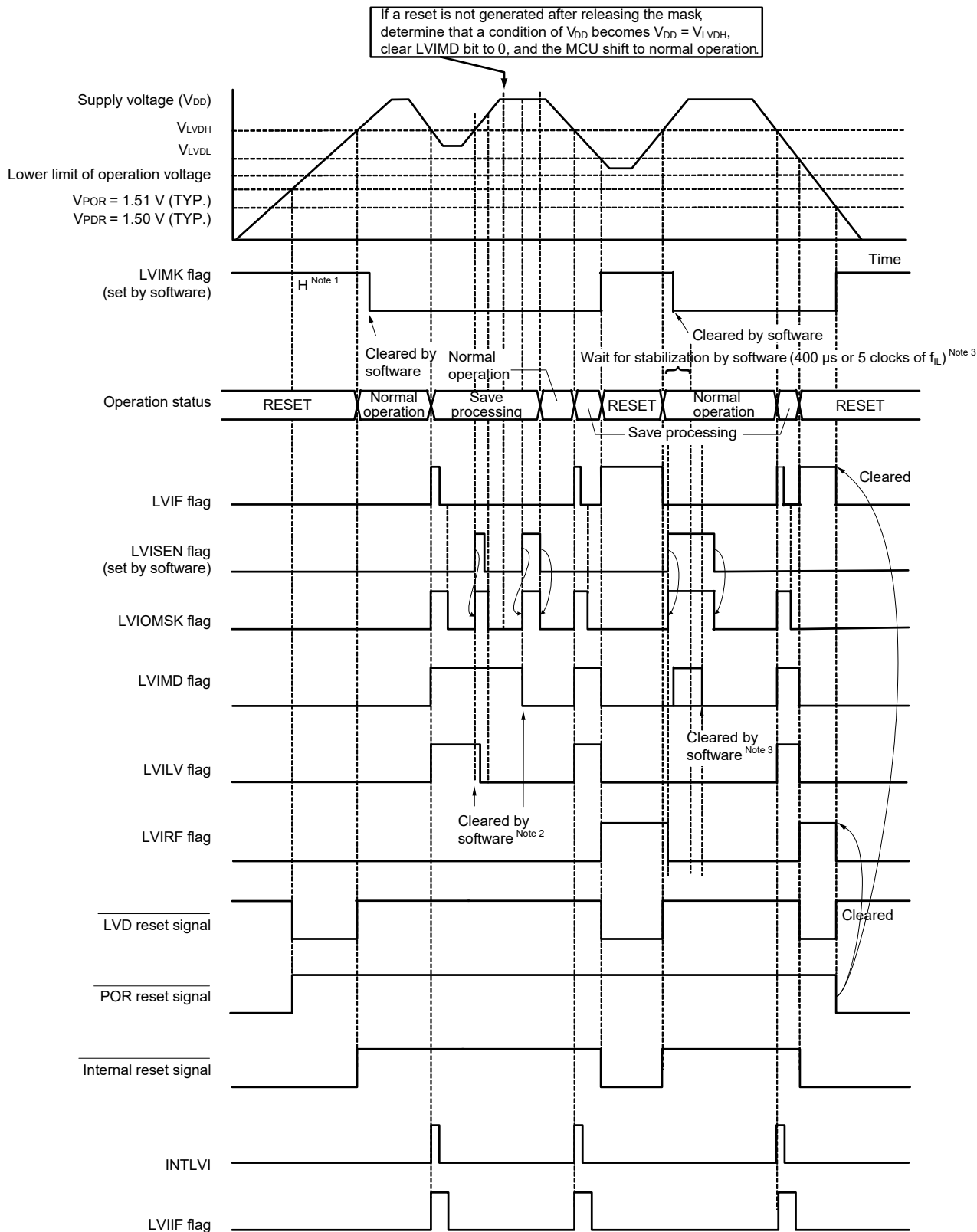

(Notes and Remark are listed on the next page.)

- Notes**
1. The LVIMK flag is set to “1” by reset signal generation.
 2. After an interrupt is generated, perform the processing according to **Figure 21-8 Processing Procedure After an Interrupt Is Generated**.
 3. After a reset is released, perform the processing according to **Figure 21-9 Initial Setting of Interrupt and Reset Mode**.

Remark V_{POR} : POR power supply rise detection voltage
 V_{PDR} : POR power supply fall detection voltage

Figure 21-7. Timing of Voltage Detector Reset Signal and Interrupt Signal Generation (Option Byte LVIMDS1, LVIMDS0 = 1, 0) (2/2)

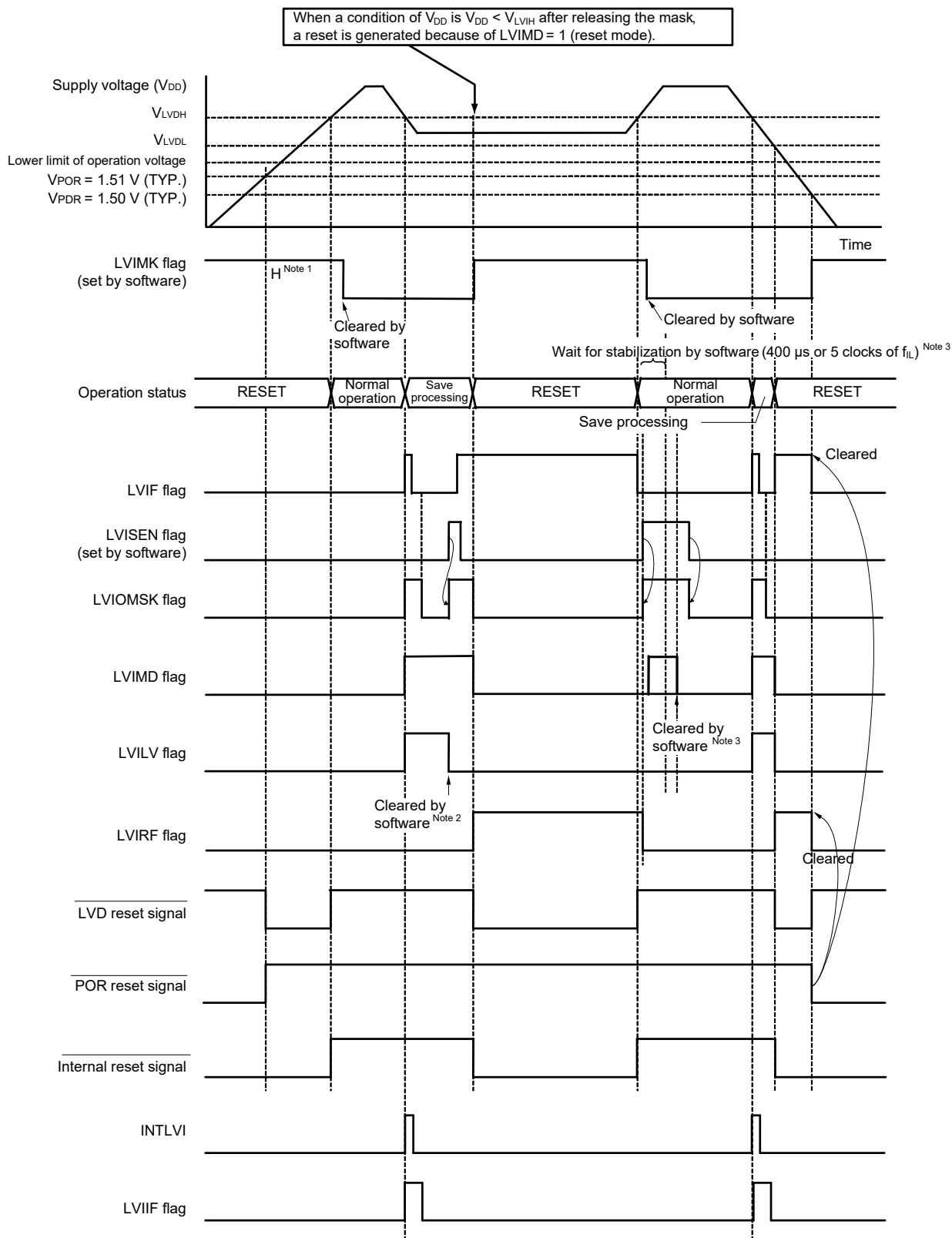

(Notes and Remark are listed on the next page.)

- Notes**
1. The LVIMK flag is set to “1” by reset signal generation.
 2. After an interrupt is generated, perform the processing according to **Figure 21-8 Processing Procedure After an Interrupt Is Generated**.
 3. After a reset is released, perform the processing according to **Figure 21-9 Initial Setting of Interrupt and Reset Mode**.

Remark V_{POR} : POR power supply rise detection voltage
 V_{PDR} : POR power supply fall detection voltage

Figure 21-8. Processing Procedure After an Interrupt Is Generated

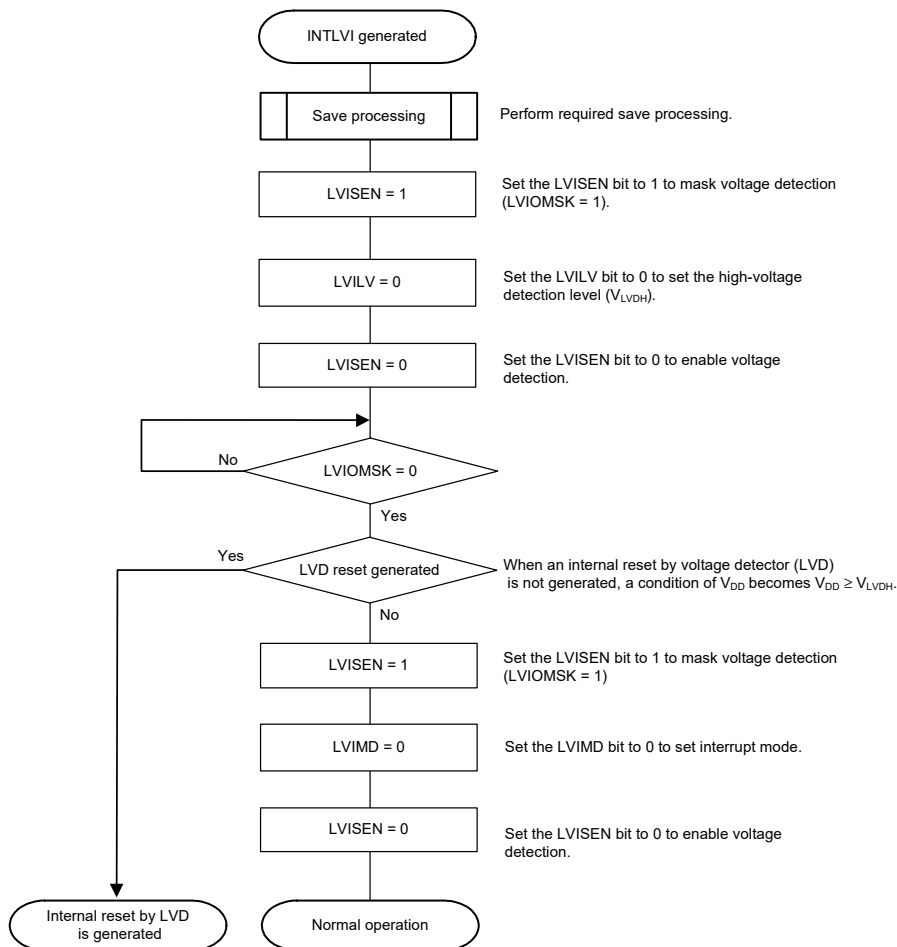

When setting an interrupt and reset mode (LVIMDS1, LVIMDS0 = 1, 0), voltage detection stabilization wait time for 400 μ s or 5 clocks of f_{IL} is necessary after LVD reset is released (LVIRF = 1). After waiting until voltage detection stabilizes, (0) clear the LVIMD bit for initialization. While voltage detection stabilization wait time is being counted and when the LVIMD bit is rewritten, set LVISEN to 1 to mask a reset or interrupt generation by LVD.

Figure 21-9 shows the procedure for initial setting of interrupt and reset mode.

Figure 21-9. Initial Setting of Interrupt and Reset Mode

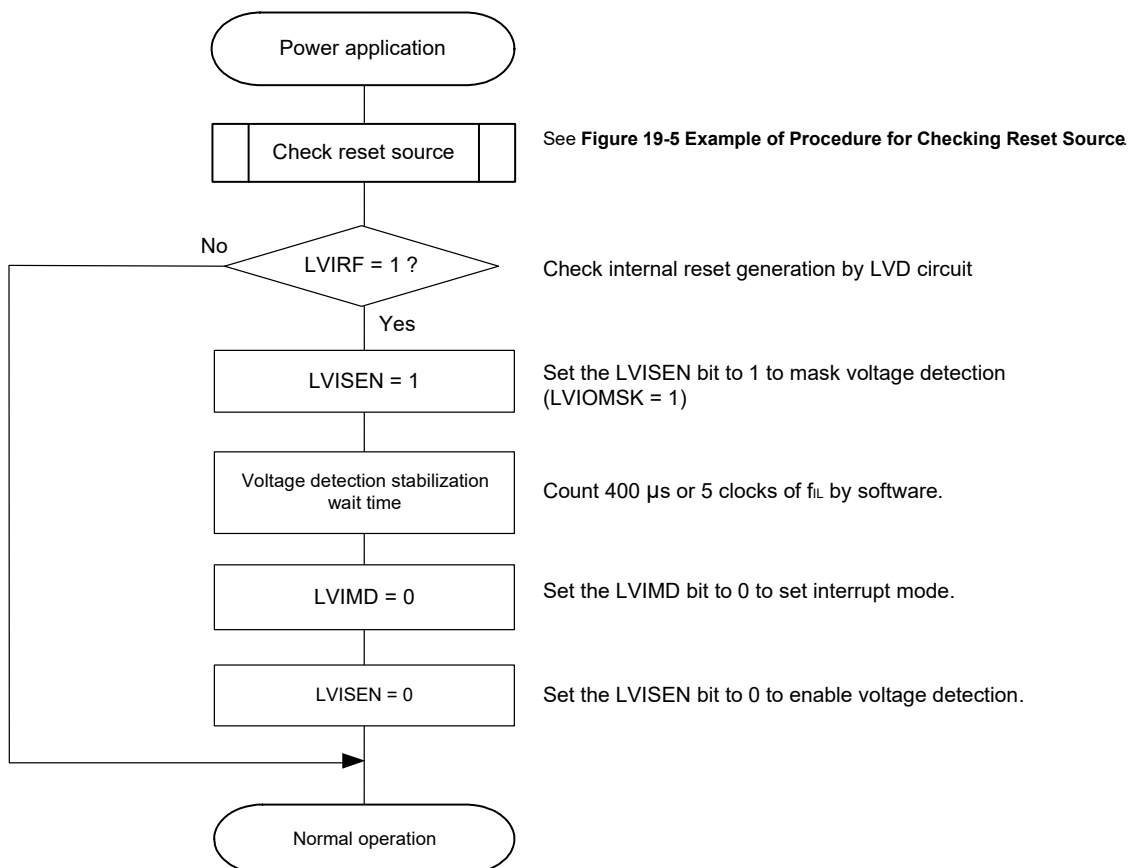

Remark f_{IL} : Low-speed on-chip oscillator clock frequency

21.5 Cautions for Voltage Detector

(1) Voltage fluctuation when power is supplied

In a system where the supply voltage (V_{DD}) fluctuates for a certain period in the vicinity of the LVD detection voltage, the system may be repeatedly reset and released from the reset status. In this case, the time from release of reset to the start of the operation of the microcontroller can be arbitrarily set by taking the following action.

<Action>

After releasing the reset signal, wait for the supply voltage fluctuation period of each system by means of a software counter that uses a timer, and then initialize the ports.

Figure 21-10. Example of Software Processing If Supply Voltage Fluctuation is 50 ms or Less in Vicinity of LVD Detection Voltage

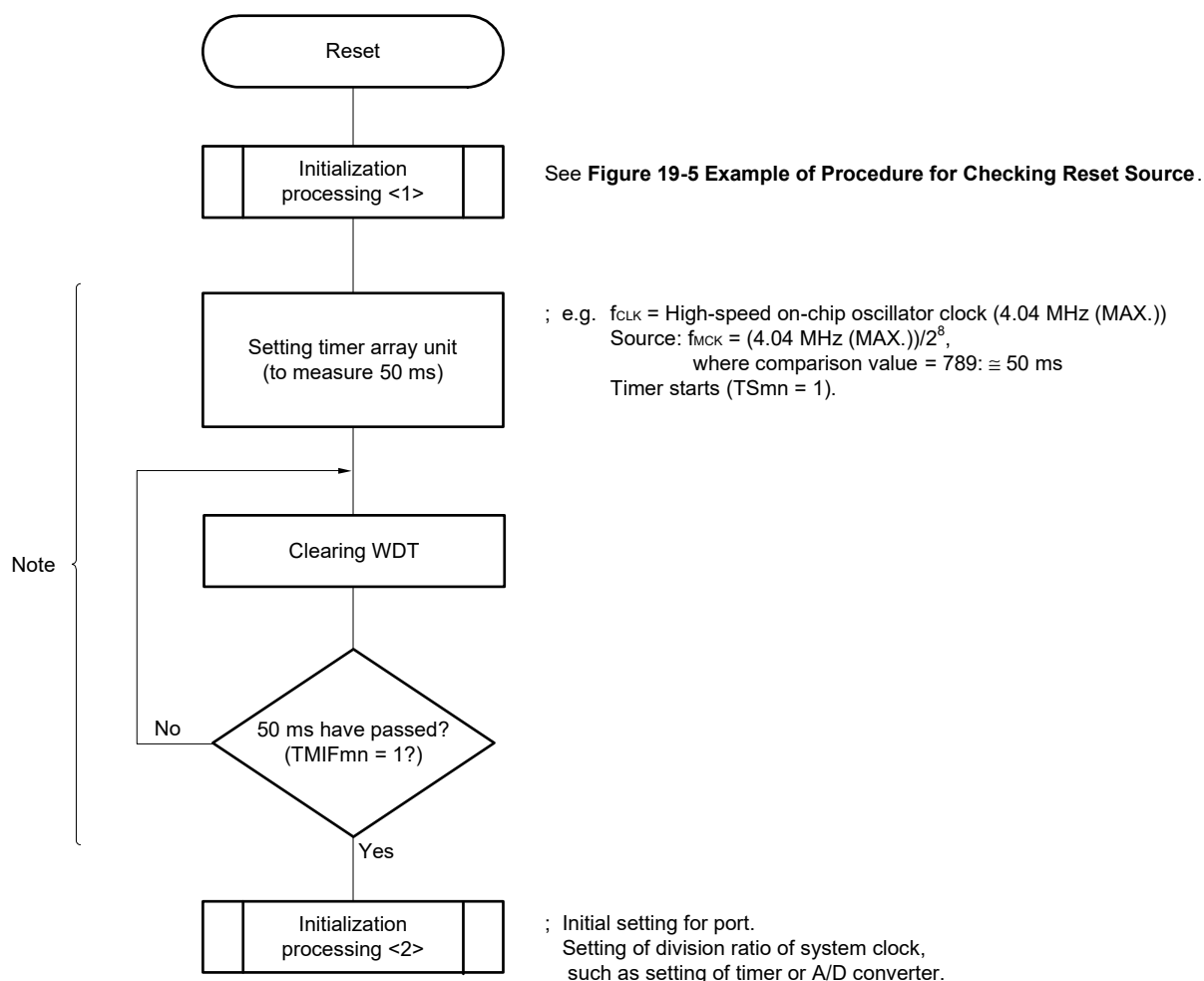

Note If reset is generated again during this period, initialization processing <2> is not started.

Remark m = 0, 1
 n = 0 to 7

(2) Delay from the time LVD reset source is generated until the time LVD reset has been generated or released

There is some delay from the time supply voltage (V_{DD}) < LVD detection voltage (V_{LVD}) until the time LVD reset has been generated.

In the same way, there is also some delay from the time LVD detection voltage (V_{LVD}) \leq supply voltage (V_{DD}) until the time LVD reset has been released (see **Figure 21-11**).

Figure 21-11. Delay from the time LVD reset source is generated until the time LVD reset has been generated or released

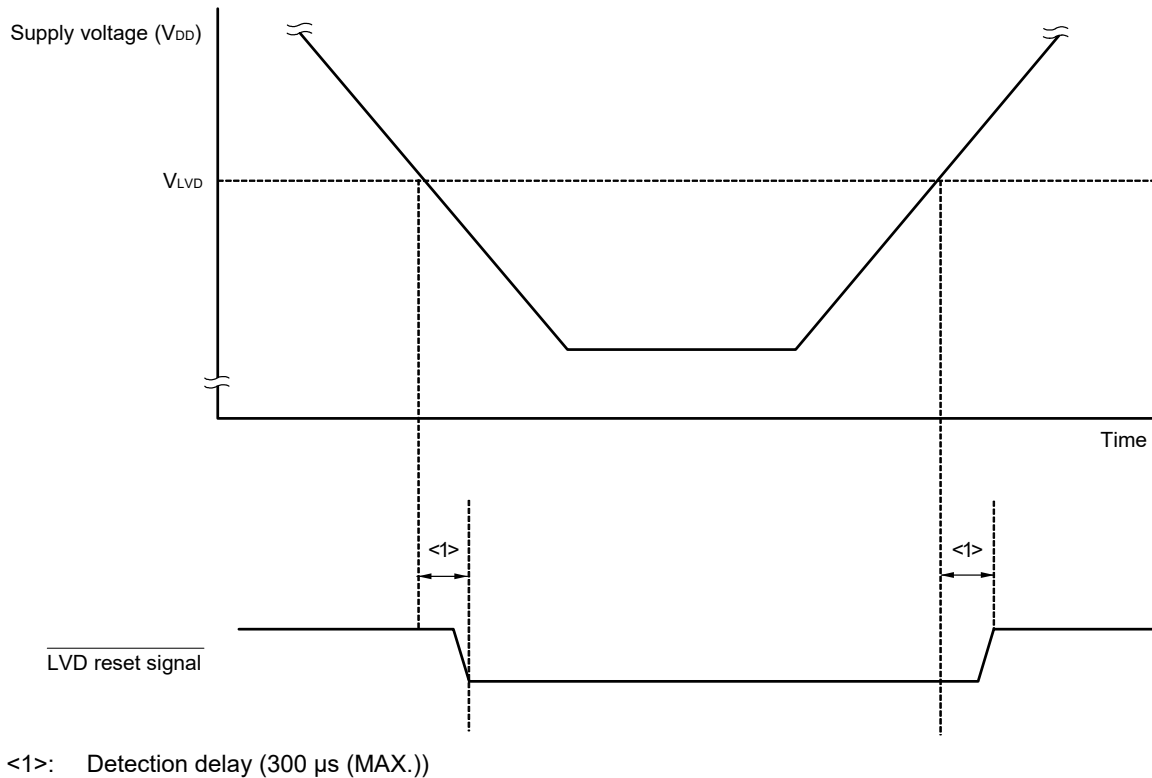
**(3) Power on when LVD is off**

Use the external reset input via the $\overline{\text{RESET}}$ pin when the LVD is off.

For an external reset, input a low level for 10 μ s or more to the $\overline{\text{RESET}}$ pin. To perform an external reset upon power application, input a low level to the $\overline{\text{RESET}}$ pin, turn power on, continue to input a low level to the pin for 10 μ s or more within the operating voltage range shown in **29.4** or **30.4 AC Characteristics**, and then input a high level to the pin.

(4) Operating voltage fall when LVD is off or LVD interrupt mode is selected

When the operating voltage falls with the LVD is off or with the LVD interrupt mode is selected, this LSI should be placed in the STOP mode, or placed in the reset state by controlling the externally input reset signal, before the voltage falls below the operating voltage range defined in **29.4** or **30.4 AC characteristics**. When restarting the operation, make sure that the operation voltage has returned within the range of operation.

CHAPTER 22 SAFETY FUNCTIONS

22.1 Overview of Safety Functions

The following safety functions are provided in the RL78/G13 to comply with the IEC60730 safety standard.

These functions enable the microcontroller to self-diagnose abnormalities and stop operating if an abnormality is detected.

(1) Flash memory CRC operation function (high-speed CRC, general-purpose CRC)

This detects data errors in the flash memory by performing CRC operations.

Two CRC functions are provided in the RL78/G13 that can be used according to the application or purpose of use.

- High-speed CRC: The CPU can be stopped and a high-speed check executed on its entire code flash memory area during the initialization routine.
- General CRC: This can be used for checking various data in addition to the code flash memory area while the CPU is running.

(2) RAM parity error detection function

This detects parity errors when reading RAM data.

(3) RAM guard function

This prevents RAM data from being rewritten when the CPU freezes.

(4) SFR guard function

This prevents SFRs from being rewritten when the CPU freezes.

(5) Invalid memory access detection function

This detects illegal accesses to invalid memory areas (such as areas where no memory is allocated and areas to which access is restricted).

(6) Frequency detection function

This function allows a self-check of the CPU/peripheral hardware clock frequencies using the timer array unit.

(7) A/D test function

This is used to perform a self-check of the A/D converter by performing A/D conversion of the A/D converter's positive and negative reference voltages, analog input channel (ANI), temperature sensor output voltage, and internal reference voltage.

Remark For usage examples of the safety functions complying with the IEC60730 safety standards, refer to **RL78 Family IEC60730/60335 self test library application notes (R01AN1062, R01AN1296)**.

22.2 Registers Used by Safety Functions

The safety functions use the following registers for each function.

Register	Each Function of Safety Function
<ul style="list-style-type: none"> Flash memory CRC control register (CRC0CTL) Flash memory CRC operation result register (PGCRCL) 	Flash memory CRC operation function (high-speed CRC)
<ul style="list-style-type: none"> CRC input register (CRCIN) CRC data register (CRCD) 	CRC operation function (general-purpose CRC)
<ul style="list-style-type: none"> RAM parity error control register (RPECTL) 	RAM parity error detection function
<ul style="list-style-type: none"> Invalid memory access detection control register (IAWCTL) 	RAM guard function
	SFR guard function
	Invalid memory access detection function
<ul style="list-style-type: none"> Timer input select register 0 (TIS0) 	Frequency detection function
<ul style="list-style-type: none"> A/D test register (ADTES) 	A/D test function

The content of each register is described in **22.3 Operation of Safety Functions**.

22.3 Operation of Safety Functions

22.3.1 Flash memory CRC operation function (high-speed CRC)

The IEC60730 standard mandates the checking of data in the flash memory, and recommends using CRC to do it. The high-speed CRC provided in the RL78/G13 can be used to check the entire code flash memory area during the initialization routine. The high-speed CRC can be executed only when the program is allocated on the RAM and in the HALT mode of the main system clock.

The high-speed CRC performs an operation by reading 32-bit data per clock from the flash memory while stopping the CPU. This function therefore can finish a check in a shorter time (for example, 512 μ s@32 MHz with 64-KB flash memory).

The CRC generator polynomial used complies with “ $X^{16} + X^{12} + X^5 + 1$ ” of CRC-16-CCITT.

The high-speed CRC operates in MSB first order from bit 31 to bit 0.

Caution The CRC operation result might differ during on-chip debugging because the monitor program is allocated.

Remark The operation result is different between the high-speed CRC and the general CRC, because the general CRC operates in LSB first order.

22.3.1.1 Flash memory CRC control register (CRC0CTL)

This register is used to control the operation of the high-speed CRC ALU, as well as to specify the operation range.

The CRC0CTL register can be set by a 1-bit or 8-bit memory manipulation instruction.

Reset signal generation clears this register to 00H.

Figure 22-1. Format of Flash Memory CRC Control Register (CRC0CTL)

Address: F02F0H After reset: 00H R/W

Symbol	<7>	6	5	4	3	2	1	0
CRC0CTL	CRC0EN	0	FEA5	FEA4	FEA3	FEA2	FEA1	FEA0

CRC0EN	Control of CRC ALU operation
0	Stop the operation.
1	Start the operation according to HALT instruction execution.

FEA5	FEA4	FEA3	FEA2	FEA1	FEA0	High-speed CRC operation range
0	0	0	0	0	0	00000H to 03FFBH (16 Kbytes - 4 bytes)
0	0	0	0	0	1	00000H to 07FFBH (32 Kbytes - 4 bytes)
0	0	0	0	1	0	00000H to 0BFFBH (48 Kbytes - 4 bytes)
0	0	0	0	1	1	00000H to 0FFFBH (64 Kbytes - 4 bytes)
0	0	0	1	0	0	00000H to 13FFBH (80 Kbytes - 4 bytes)
0	0	0	1	0	1	00000H to 17FFBH (96 Kbytes - 4 bytes)
0	0	0	1	1	0	00000H to 1BFFBH (112 Kbytes - 4 bytes)
0	0	0	1	1	1	00000H to 1FFFBH (128 Kbytes - 4 bytes)
0	0	1	0	0	0	00000H to 23FFBH (144 Kbytes - 4 bytes)
0	0	1	0	0	1	00000H to 27FFBH (160 Kbytes - 4 bytes)
0	0	1	0	1	0	00000H to 2BFFBH (176 Kbytes - 4 bytes)
0	0	1	0	1	1	00000H to 2FFFBH (192 Kbytes - 4 bytes)
0	0	1	1	0	0	00000H to 33FFBH (208 Kbytes - 4 bytes)
0	0	1	1	0	1	00000H to 37FFBH (224 Kbytes - 4 bytes)
0	0	1	1	1	0	00000H to 3BFFBH (240 Kbytes - 4 bytes)
0	0	1	1	1	1	00000H to 3FFFBH (256 Kbytes - 4 bytes)
0	1	0	0	0	0	00000H to 43FFBH (272 Kbytes - 4 bytes)
0	1	0	0	0	1	00000H to 47FFBH (288 Kbytes - 4 bytes)
0	1	0	0	1	0	00000H to 4BFFBH (304 Kbytes - 4 bytes)
0	1	0	0	1	1	00000H to 4FFFBH (320 Kbytes - 4 bytes)
0	1	0	1	0	0	00000H to 53FFBH (336 Kbytes - 4 bytes)
0	1	0	1	0	1	00000H to 57FFBH (352 Kbytes - 4 bytes)
0	1	0	1	1	0	00000H to 5BFFBH (368 Kbytes - 4 bytes)
0	1	0	1	1	1	00000H to 5FFFBH (384 Kbytes - 4 bytes)
0	1	1	0	0	0	00000H to 63FFBH (400 Kbytes - 4 bytes)
0	1	1	0	0	1	00000H to 67FFBH (416 Kbytes - 4 bytes)
0	1	1	0	1	0	00000H to 6BFFBH (432 Kbytes - 4 bytes)
0	1	1	0	1	1	00000H to 6FFFBH (448 Kbytes - 4 bytes)
0	1	1	1	0	0	00000H to 73FFBH (464 Kbytes - 4 bytes)
0	1	1	1	0	1	00000H to 77FFBH (480 Kbytes - 4 bytes)
0	1	1	1	1	0	00000H to 7BFFBH (496 Kbytes - 4 bytes)
0	1	1	1	1	1	00000H to 7FFFBH (512 Kbytes - 4 bytes)
Other than the above						Setting prohibited

Remark Input the expected CRC operation result value to be used for comparison in the lowest 4 bytes of the flash memory. Note that the operation range will thereby be reduced by 4 bytes.

22.3.1.2 Flash memory CRC operation result register (PGCRCL)

This register is used to store the high-speed CRC operation results.

The PGCRCL register can be set by a 16-bit memory manipulation instruction.

Reset signal generation clears this register to 0000H.

Figure 22-2. Format of Flash Memory CRC Operation Result Register (PGCRCL)

Address: F02F2H After reset: 0000H R/W

Symbol	15	14	13	12	11	10	9	8
PGCRCL	PGCRC15	PGCRC14	PGCRC13	PGCRC12	PGCRC11	PGCRC10	PGCRC9	PGCRC8
	7	6	5	4	3	2	1	0
	PGCRC7	PGCRC6	PGCRC5	PGCRC4	PGCRC3	PGCRC2	PGCRC1	PGCRC0
	PGCRC15 to 0		High-speed CRC operation results					
	0000H to FFFFH		Store the high-speed CRC operation results.					

Caution The PGCRCL register can only be written if CRC0EN (bit 7 of the CRC0CTL register) = 1.

Figure 22-3 shows the flowchart of flash memory CRC operation function (high-speed CRC).

<Operation flow>

Figure 22-3. Flowchart of Flash Memory CRC Operation Function (High-speed CRC)

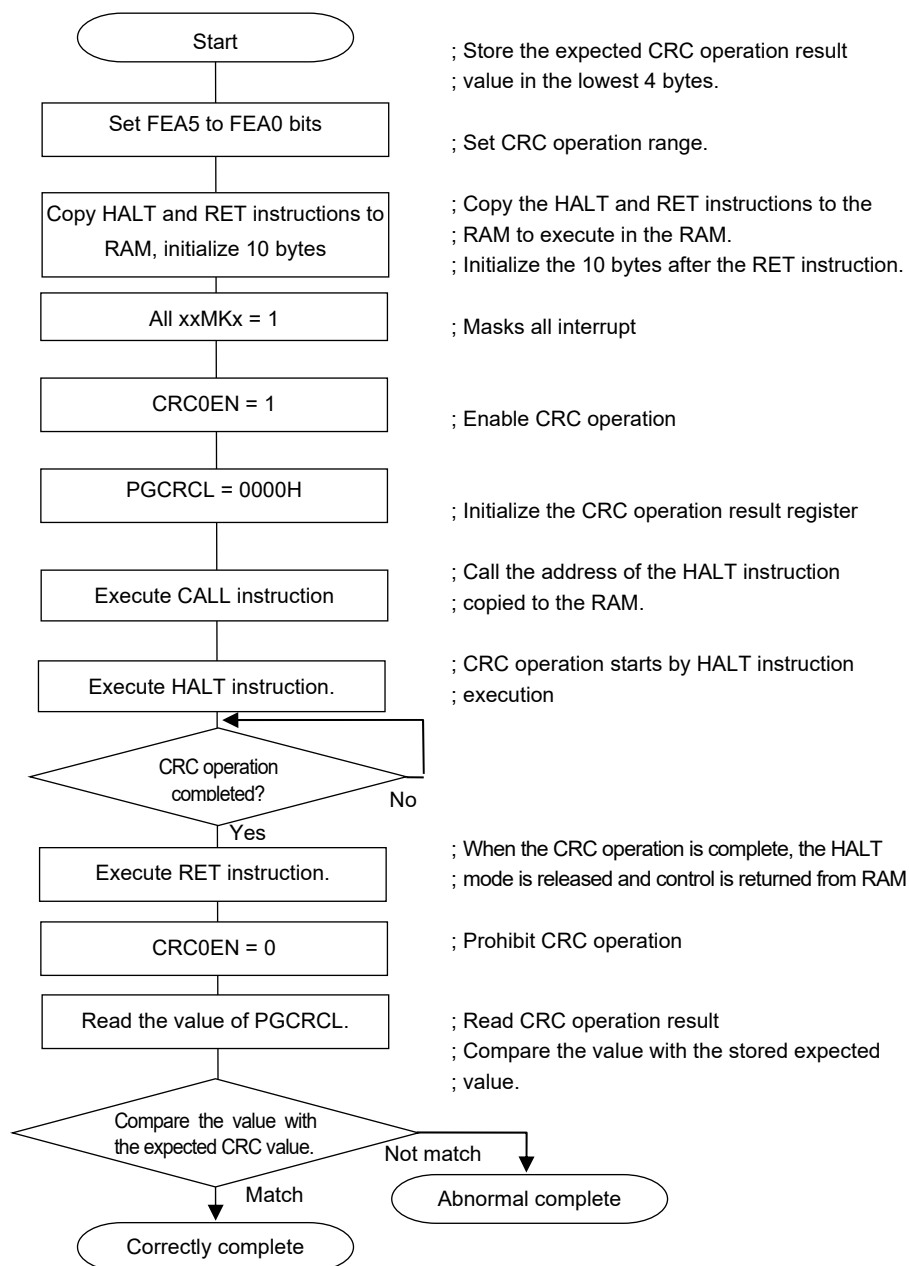

- Cautions**
1. The CRC operation is executed only on the code flash.
 2. Store the expected CRC operation value in the area below the operation range in the code flash.
 3. The CRC operation is enabled by executing the HALT instruction in the RAM area.
- Be sure to execute the HALT instruction in RAM area.

The expected CRC value can be calculated by using the Integrated Development Environment CubeSuite+. See the Integrated Development Environment CubeSuite+ user's manual for details.

22.3.2 CRC operation function (general-purpose CRC)

In the RL78/G13, a general CRC operation can be executed as a peripheral function while the CPU is operating. The general CRC can be used for checking various data in addition to the code flash memory area. The data to be checked can be specified by using software (a user-created program). CRC calculation function in the HALT mode can be used only during the DMA transmission.

The general CRC operation can be executed in the main system clock operation mode as well as the subsystem clock operation mode.

The CRC generator polynomial used is “ $X^{16} + X^{12} + X^5 + 1$ ” of CRC-16-CCITT. The data to be input is inverted in bit order and then calculated to allow for LSB-first communication. For example, if the data 12345678H is sent from the LSB, values are written to the CRCIN register in the order of 78H, 56H, 34H, and 12H, enabling a value of 08F6H to be obtained from the CRCD register. This is the result obtained by executing a CRC operation on the bit rows shown below, which consist of the data 12345678H inverted in bit order.

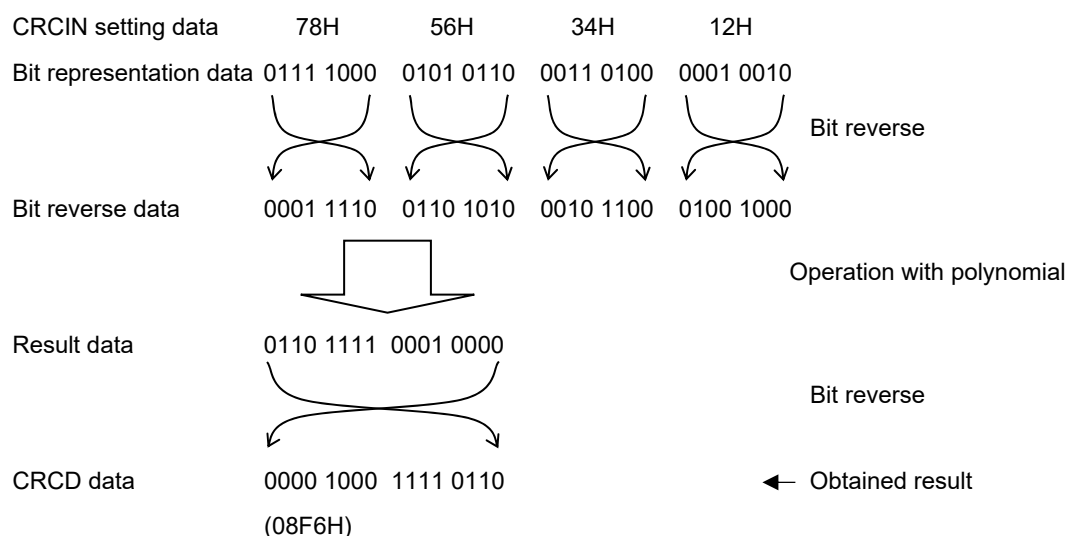

Caution Because the debugger rewrites the software break setting line to a break instruction during program execution, the CRC operation result differs if a software break is set in the CRC operation target area.

<Control register>

22.3.2.1 CRC input register (CRCIN)

CRCIN register is an 8-bit register that is used to set the CRC operation data of general-purpose CRC.

The possible setting range is 00H to FFH.

The CRCIN register can be set by an 8-bit memory manipulation instruction.

Reset signal generation clears this register to 00H.

Figure 22-4. Format of CRC Input Register (CRCIN)

Address: FFFACH After reset: 00H R/W

Symbol	7	6	5	4	3	2	1	0
CRCIN								
	Bits 7 to 0				Function			
	00H to FFH				Data input.			

22.3.2.2 CRC data register (CRCD)

This register is used to store the CRC operation result of the general-purpose CRC.

The setting range is 0000H to FFFFH.

After 1 clock of CPU/peripheral hardware clock (f_{CLK}) has elapsed from the time CRCIN register is written, the CRC operation result is stored to the CRCD register.

The CRCD register can be set by a 16-bit memory manipulation instruction.

Reset signal generation clears this register to 0000H.

Figure 22-5. Format of CRC Data Register (CRCD)

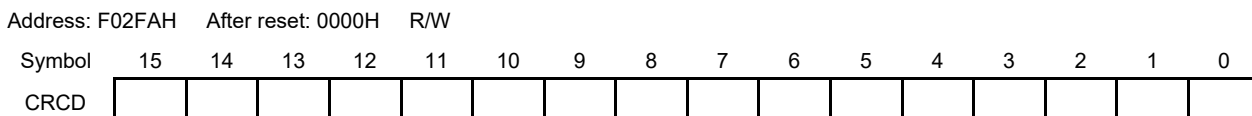

- Cautions**
1. Read the value written to CRCD register before writing to CRCIN register.
 2. If conflict between writing and storing operation result to CRCD register occurs, the writing is ignored.

<Operation flow>

Figure 22-6. CRC Operation Function (General-Purpose CRC)

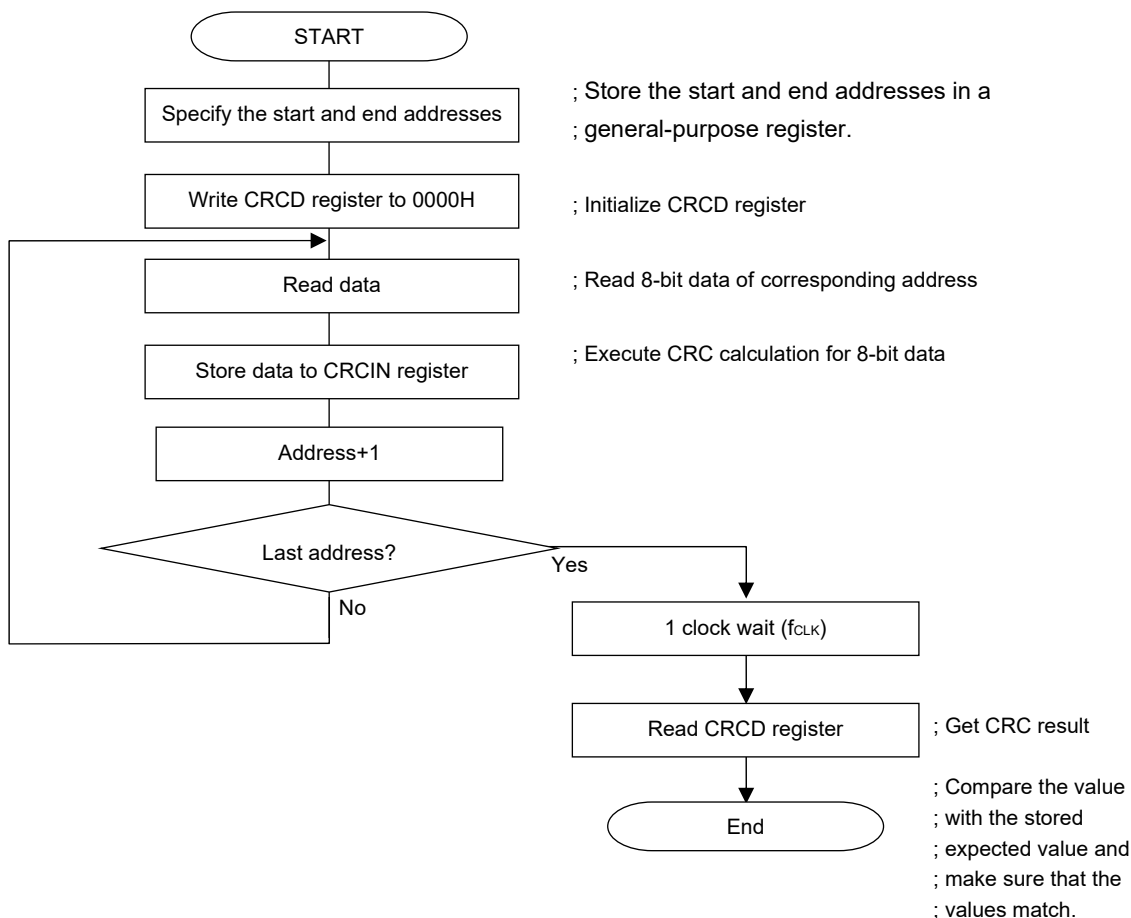

22.3.3 RAM parity error detection function

The IEC60730 standard mandates the checking of RAM data. A single-bit parity bit is therefore added to all 8-bit data in the RL78/G13’s RAM. By using this RAM parity error detection function, the parity bit is appended when data is written, and the parity is checked when the data is read. This function can also be used to trigger a reset when a parity error occurs.

<Control register>

22.3.3.1 RAM parity error control register (RPECTL)

This register is used to control parity error generation check bit and reset generation due to parity errors. The RPECTL register can be set by a 1-bit or 8-bit memory manipulation instruction. Reset signal generation clears this register to 00H.

Figure 22-7. Format of RAM Parity Error Control Register (RPECTL)

Address: F00F5H After reset: 00H R/W

Symbol	<7>	6	5	4	3	2	1	<0>
RPECTL	RPERDIS	0	0	0	0	0	0	RPEF

RPERDIS	Parity error reset mask flag
0	Enable parity error resets.
1	Disable parity error resets.

RPEF	Parity error status flag
0	No parity error has occurred.
1	A parity error has occurred.

Caution The parity bit is appended when data is written, and the parity is checked when the data is read. Therefore, while RAM parity error resets are enabled (RPERDIS = 0), be sure to initialize RAM areas where data access is to proceed before reading data. The RL78’s CPU executes look-ahead due to the pipeline operation, the CPU might read an uninitialized RAM area that is allocated beyond the RAM used, which causes a RAM parity error. Therefore, while RAM parity error resets are enabled (RPERDIS = 0), be sure to initialize the RAM area + 10 bytes when instructions are fetched from RAM areas. When using the self-programming function while RAM parity error resets are enabled (RPERDIS = 0), be sure to initialize the RAM area to overwrite + 10 bytes before overwriting.

- Remarks**
1. The parity error reset is enabled by default (RPERDIS = 0).
 2. Even if the parity error reset is disabled (RPERDIS = 1), the RPEF flag will be set (1) if a parity error occurs. If parity error resets are enabled (RPERDIS = 0) with RPEF set to 1, a parity error reset is generated when the RPERDIS bit is cleared to 0.
 3. The RPEF flag in the RPECTL register is set (1) when the RAM parity error occurs and cleared (0) by writing 0 to it or by any reset source. When RPEF = 1, the value is retained even if RAM for which no parity error has occurred is read.
 4. The general registers are not included for RAM parity error detection.

Figure 22-8. Flowchart of RAM Parity Check

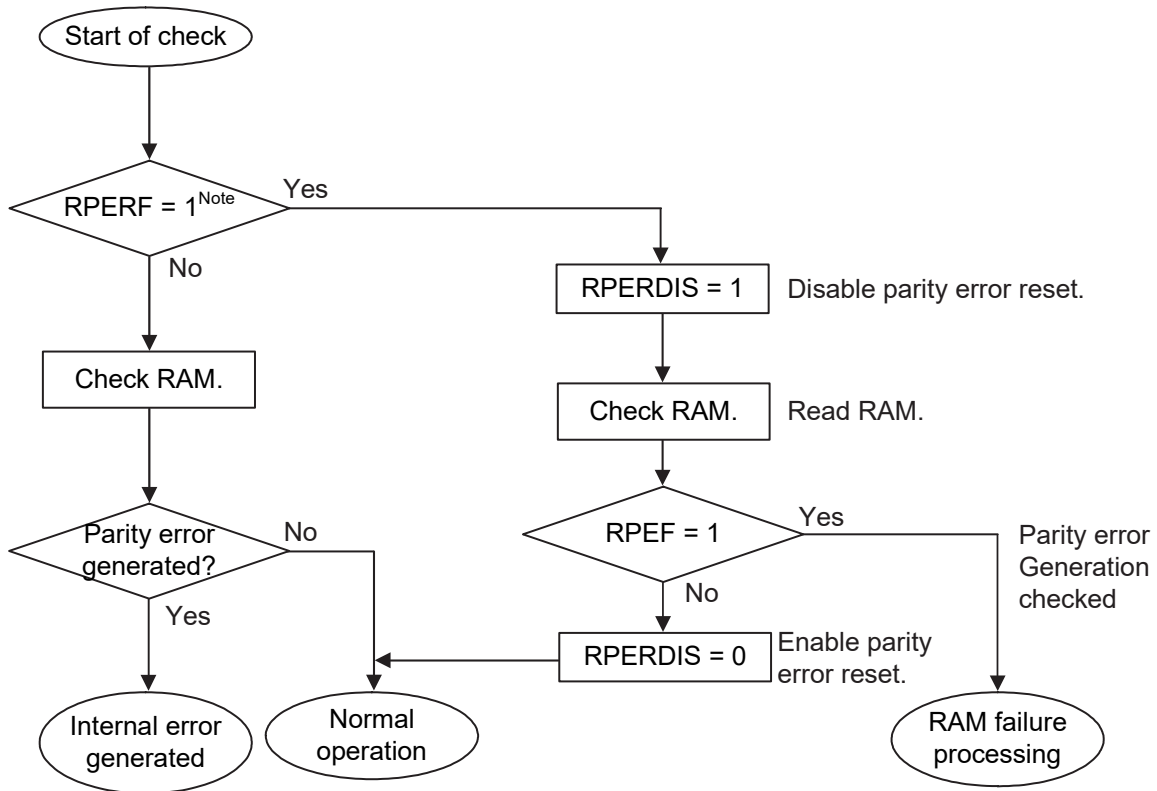

Note To check internal reset status using a RAM parity error, see **CHAPTER 19 RESET FUNCTION**.

22.3.4 RAM guard function

This RAM guard function is used to protect data in the specified memory space.

If the RAM guard function is specified, writing to the specified RAM space is disabled, but reading from the space can be carried out as usual.

22.3.4.1 Invalid memory access detection control register (IAWCTL)

This register is used to control the detection of invalid memory access and RAM/SFR guard function.

GRAM1 and GRAM0 bits are used in RAM guard function.

The IAWCTL register can be set by an 8-bit memory manipulation instruction.

Reset signal generation clears this register to 00H.

Figure 22-9. Format of Invalid Memory Access Detection Control Register (IAWCTL)

Address: F0078H After reset: 00H R/W

Symbol	7	6	5	4	3	2	1	0
IAWCTL	IAWEN	0	GRAM1	GRAM0	0	GPORT	GINT	GCSC

GRAM1	GRAM0	RAM guard space ^{Note}
0	0	Disabled. RAM can be written to.
0	1	The 128 bytes of space starting at the start address in the RAM
1	0	The 256 bytes of space starting at the start address in the RAM
1	1	The 512 bytes of space starting at the start address in the RAM

Note The RAM start address differs depending on the size of the RAM provided with the product.

22.3.5 SFR guard function

This SFR guard function is used to protect data in the control registers used by the port function, interrupt function, clock control function, voltage detection function, and RAM parity error detection function.

If the SFR guard function is specified, writing to the specified SFRs is disabled, but reading from the SFRs can be carried out as usual.

22.3.5.1 Invalid memory access detection control register (IAWCTL)

This register is used to control the detection of invalid memory access and RAM/SFR guard function.

GPORT, GINT and GCSC bits are used in SFR guard function.

The IAWCTL register can be set by an 8-bit memory manipulation instruction.

Reset signal generation clears this register to 00H.

Figure 22-10. Format of Invalid Memory Access Detection Control Register (IAWCTL)

Address: F0078H After reset: 00H R/W

Symbol	7	6	5	4	3	2	1	0
IAWCTL	IAWEN	0	GRAM1	GRAM0	0	GPORT	GINT	GCSC

GPORT	Control registers of port function guard
0	Disabled. Control registers of port function can be read or written to.
1	Enabled. Writing to control registers of port function is disabled. Reading is enabled. [Guarded SFR] PMxx, PUxx, PIMxx, POMxx, PMCxx, ADPC, PIOR ^{Note}

GINT	Registers of interrupt function guard
0	Disabled. Registers of interrupt function can be read or written to.
1	Enabled. Writing to registers of interrupt function is disabled. Reading is enabled. [Guarded SFR] IFxx, MKxx, PRxx, EGPx, EGNx

GCSC	Control registers of clock control function, voltage detector and RAM parity error detection function guard
0	Disabled. Control registers of clock control function, voltage detector and RAM parity error detection function can be read or written to.
1	Enabled. Writing to control registers of clock control function, voltage detector and RAM parity error detection function is disabled. Reading is enabled. [Guarded SFR] CMC, CSC, OSTs, CKC, PERx, OSMC, LVIM, LVIS, RPECTL

Note Pxx (Port register) is not guarded.

22.3.6 Invalid memory access detection function

The IEC60730 standard mandates checking that the CPU and interrupts are operating correctly.

The illegal memory access detection function triggers a reset if a memory space specified as access-prohibited is accessed.

The illegal memory access detection function applies to the areas indicated by NG in Figure 22-11.

Figure 22-11. Invalid access detection area

		Accessibility		
		Read	Write	Instruction fetch (execution)
FFFFFH	Special function register (SFR) 256 bytes			NG
FFF00H FFEFFH	General-purpose register 32 bytes		OK	
FFEE0H FFEDFH				
	RAM ^{Note}			OK
zzzzzH				
	Mirror	OK	NG	NG
	Data flash memory		NG	NG
F1000H F0FFFH	Reserved			OK
F0800H F07FFH	Special function register (2nd SFR) 2 Kbytes		OK	NG
F0000H EFFFFH				OK
EF000H EEFFFH				
	Reserved	NG	NG	NG
			NG	
yyyyyH				
xxxxxH				
	Code flash memory ^{Note}	OK		OK
00000H				

Note The following table lists the code flash memory, RAM, and lowest detection address for each product:

Products	Code flash memory (00000H to xxxxxH)	RAM (zzzzzH to FFEFFH)	Detected lowest address for read/instruction fetch (execution) (yyyyyH)
R5F100xA, R5F101xA (x = 6 to 8, A to C, E to G)	16384 × 8 bits (00000H to 03FFFFH)	2048 × 8 bits (FF700H to FFEFFH)	10000H
R5F100xC, R5F101xC (x = 6 to 8, A to C, E to G, J, L)	32768 × 8 bits (00000H to 07FFFFH)	2048 × 8 bits (FF700H to FFEFFH)	10000H
R5F100xD, R5F101xD (x = 6 to 8, A to C, E to G, J, L)	49152 × 8 bits (00000H to 0BFFFFH)	3072 × 8 bits (FF300H to FFEFFH)	10000H
R5F100xE, R5F101xE (x = 6 to 8, A to C, E to G, J, L)	65536 × 8 bits (00000H to 0FFFFH)	4096 × 8 bits (FEF00H to FFEFFH)	10000H
R5F100xF, R5F101xF (x = A to C, E to G, J, L, M, P)	98304 × 8 bits (00000H to 17FFFFH)	8192 × 8 bits (FDF00H to FFEFFH)	20000H
R5F100xG, R5F101xG (x = A to C, E to G, J, L, M, P)	131072 × 8 bits (00000H to 1FFFFH)	12288 × 8 bits (FCF00H to FFEFFH)	20000H
R5F100xH, R5F101xH (x = E to G, J, L, M, P, S)	196608 × 8 bits (00000H to 2FFFFH)	16384 × 8 bits (FBF00H to FFEFFH)	30000H
R5F100xJ, R5F101xJ (x = F, G, J, L, M, P, S)	262144 × 8 bits (00000H to 3FFFFH)	20480 × 8 bits (FAF00H to FFEFFH)	40000H
R5F100xK, R5F101xK (x = F, G, J, L, M, P, S)	393216 × 8 bits (00000H to 5FFFFH)	24576 × 8 bits (F9F00H to FFEFFH)	60000H
R5F100xL, R5F101xL (x = F, G, J, L, M, P, S)	524288 × 8 bits (00000H to 7FFFFH)	32768 × 8 bits (F7F00H to FFEFFH)	80000H

22.3.6.1 Invalid memory access detection control register (IAWCTL)

This register is used to control the detection of invalid memory access and RAM/SFR guard function. IAWEN bit is used in invalid memory access detection function. The IAWCTL register can be set by an 8-bit memory manipulation instruction. Reset signal generation clears this register to 00H.

Figure 22-12. Format of Invalid Memory Access Detection Control Register (IAWCTL)

Address: F0078H After reset: 00H R/W

Symbol	7	6	5	4	3	2	1	0
IAWCTL	IAWEN	0	GRAM1	GRAM0	0	GPORT	GINT	GCSC

IAWEN ^{Note}	Control of invalid memory access detection
0	Disable the detection of invalid memory access.
1	Enable the detection of invalid memory access.

Note Only writing 1 to the IAWEN bit is enabled, not writing 0 to it after setting it to 1.

Remark By specifying WDTON = 1 (watchdog timer operation enable) for the option byte (000C0H), the invalid memory access function is enabled even IAWEN = 0.

22.3.7 Frequency detection function

The IEC60730 standard mandates checking that the oscillation frequency is correct.

By using the CPU/peripheral hardware clock frequency (f_{CLK}) and measuring the pulse width of the input signal to channel 5 of the timer array unit 0 (TAU0), whether the proportional relationship between the two clock frequencies is correct can be determined. Note that, however, if one or both clock operations are completely stopped, the proportional relationship between the clocks cannot be determined.

<Clocks to be compared>

<1> CPU/peripheral hardware clock frequency (f_{CLK}):

- High-speed on-chip oscillator clock (f_{IH})
- High-speed system clock (f_{MX})

<2> Input to channel 5 of the timer array unit

- Timer input to channel 5 (TI05)
- Low-speed on-chip oscillator clock (f_{IL} : 15 kHz (typ.))
- Subsystem clock (f_{SUB}) **Note**

Figure 22-13. Configuration of Frequency Detection Function

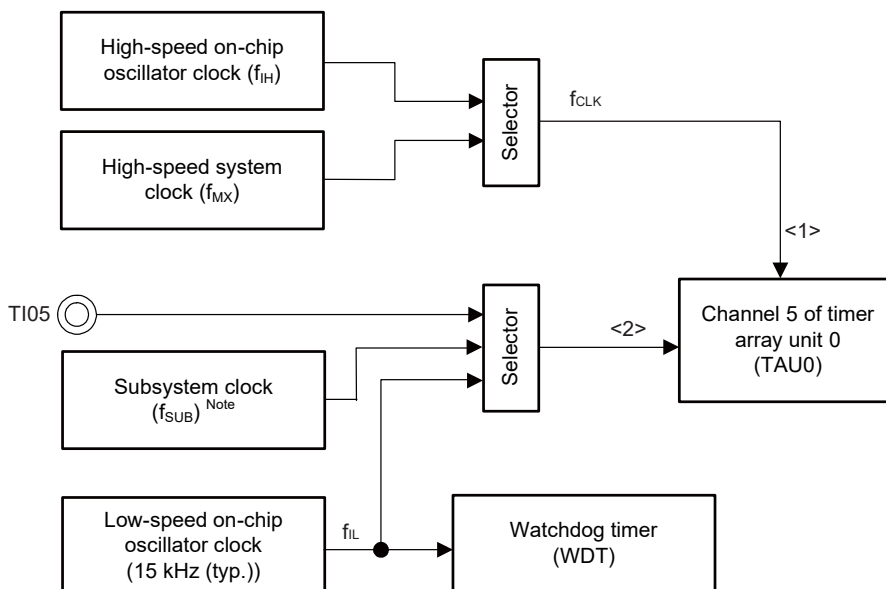

If input pulse interval measurement results in an abnormal value, it can be concluded that the clock frequency is abnormal.

For how to execute input pulse interval measurement, see **6.8.4 Operation as input pulse interval measurement**.

Note Can only be selected in the products incorporating the subsystem clock.

22.3.7.1 Timer input select register 0 (TIS0)

The TIS0 register is used to select the timer input of channel 5 of the timer array unit 0 (TAU0).

The TIS0 register can be set by an 8-bit memory manipulation instruction.

Reset signal generation clears this register to 00H.

Figure 22-14. Format of Timer Input Select Register 0 (TIS0)

Address: F0074H After reset: 00H R/W

Symbol	7	6	5	4	3	2	1	0
TIS0	0	0	0	0	0	TIS02	TIS01	TIS00

TIS02	TIS01	TIS00	Selection of timer input used with channel 5
0	0	0	Input signal of timer input pin (TI05)
0	0	1	
0	1	0	
0	1	1	
1	0	0	Low-speed on-chip oscillator clock (f_{IL})
1	0	1	Subsystem clock (f_{SUB})
Other than the above			Setting prohibited

22.3.8 A/D test function

The IEC60730 standard mandates testing the A/D converter. The A/D test function checks whether or not the A/D converter is operating normally by executing A/D conversions of the A/D converter's positive and negative reference voltages, analog input channel (ANI), temperature sensor output voltage, and the internal reference voltage. For details of the check method, see the safety function (A/D test) application note (R01AN0955).

The analog multiplexer can be checked using the following procedure.

- <1> Select the ANIx pin for A/D conversion using the ADTES register (ADTES1 = 0, ADTES0 = 0).
- <2> Perform A/D conversion for the ANIx pin (conversion result 1-1).
- <3> Select the A/D converter's negative reference voltage for A/D conversion using the ADTES register (ADTES1 = 1, ADTES0 = 0)
- <4> Perform A/D conversion of the negative reference voltage of the A/D converter (conversion result 2-1).
- <5> Select the ANIx pin for A/D conversion using the ADTES register (ADTES1 = 0, ADTES0 = 0).
- <6> Perform A/D conversion for the ANIx pin (conversion result 1-2).
- <7> Select the A/D converter's positive reference voltage for A/D conversion using the ADTES register (ADTES1 = 1, ADTES0 = 1)
- <8> Perform A/D conversion of the positive reference voltage of the A/D converter (conversion result 2-2).
- <9> Select the ANIx pin for A/D conversion using the ADTES register (ADTES1 = 0, ADTES0 = 0).
- <10> Perform A/D conversion for the ANIx pin (conversion result 1-3).
- <11> Check that the conversion results 1-1, 1-2, and 1-3 are equal.
- <12> Check that the A/D conversion result 2-1 is all zero and conversion result 2-2 is all one.

Using the procedure above can confirm that the analog multiplexer is selected and all wiring is connected.

- Remarks 1.** If the analog input voltage is variable during A/D conversion in steps <1> to <10> above, use another method to check the analog multiplexer.
- 2.** The conversion results might contain an error. Consider an appropriate level of error when comparing the conversion results.

Figure 22-15. Configuration of A/D Test Function

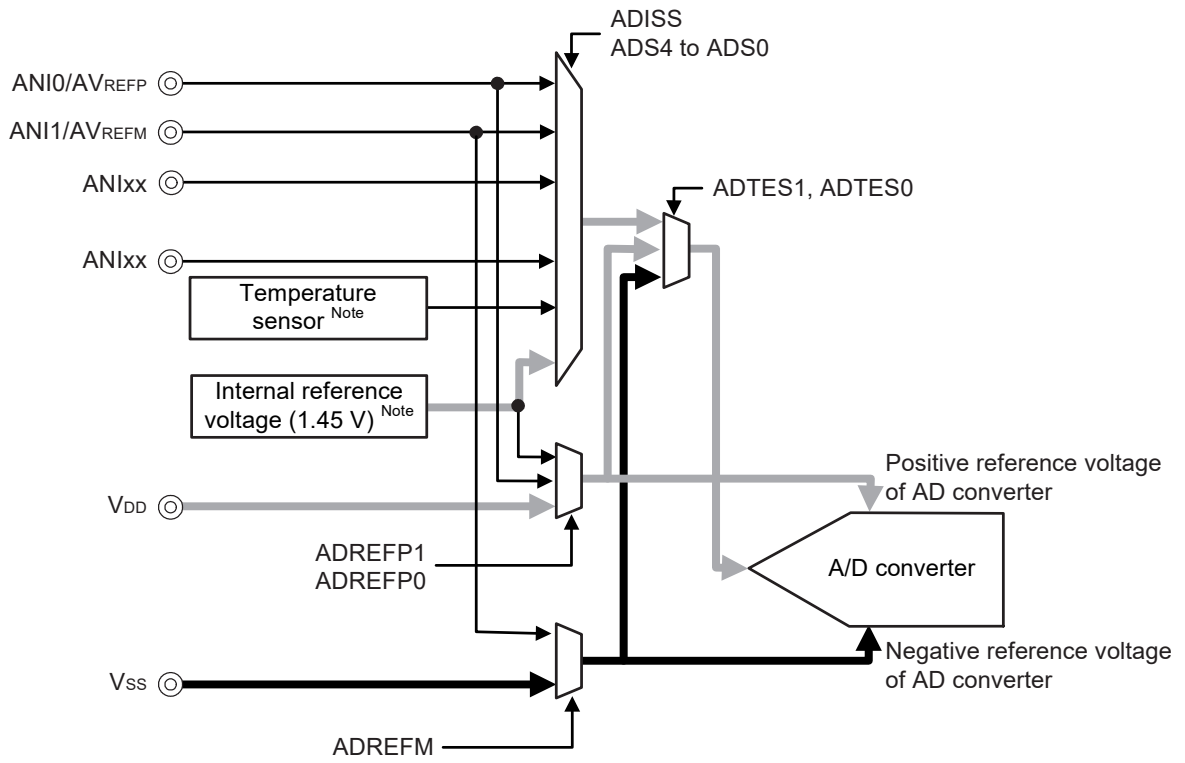

Note This setting can be used only in HS (high-speed main) mode.

22.3.8.1 A/D test register (ADTES)

This register is used to select the A/D converter's positive reference voltage, A/D converter's negative reference voltage, analog input channel (ANLxx), temperature sensor output voltage, or internal reference voltage (1.45 V) as the target of A/D conversion.

When using the A/D test function, specify the following settings:

- Select negative reference voltage as the target of A/D conversion for zero-scale measurement.
- Select positive reference voltage as the target of A/D conversion for full-scale measurement.

The ADTES register can be set by an 8-bit memory manipulation instruction.

Reset signal generation clears this register to 00H.

Figure 22-16. Format of A/D Test Register (ADTES)

Address: F0013H After reset: 00H R/W

Symbol	7	6	5	4	3	2	1	0
ADTES	0	0	0	0	0	0	ADTES1	ADTES0

ADTES1	ADTES0	A/D conversion target
0	0	ANLxx/temperature sensor output voltage ^{Note} /internal reference voltage (1.45 V) ^{Note} (This is specified using the analog input channel specification register (ADS).)
1	0	Negative reference voltage (selected with the ADREFM bit in ADM2)
1	1	Positive reference voltage (selected with the ADREFP1 or ADREFP0 bit in ADM2)
Other than the above		Setting prohibited

Note Temperature sensor output voltage and internal reference voltage (1.45 V) can be used only in HS (high-speed main) mode.

22.3.8.2 Analog input channel specification register (ADS)

This register specifies the input channel of the analog voltage to be A/D converted.

Set A/D test register (ADTES) to 00H when measuring the ANIxx/temperature sensor output voltage/internal reference voltage (1.45 V).

The ADS register can be set by a 1-bit or 8-bit memory manipulation instruction.

Reset signal generation clears this register to 00H.

Figure 22-17. Format of Analog Input Channel Specification Register (ADS)

Address: FFF31H After reset: 00H R/W

Symbol	7	6	5	4	3	2	1	0
ADS	ADISS	0	0	ADS4	ADS3	ADS2	ADS1	ADS0

0 Select mode (ADMD = 0)

ADISS	ADS4	ADS3	ADS2	ADS1	ADS0	Analog input channel	Input source
0	0	0	0	0	0	ANI0	P20/ANI0/AV _{REFP} pin
0	0	0	0	0	1	ANI1	P21/ANI1/AV _{REFM} pin
0	0	0	0	1	0	ANI2	P22/ANI2 pin
0	0	0	0	1	1	ANI3	P23/ANI3 pin
0	0	0	1	0	0	ANI4	P24/ANI4 pin
0	0	0	1	0	1	ANI5	P25/ANI5 pin
0	0	0	1	1	0	ANI6	P26/ANI6 pin
0	0	0	1	1	1	ANI7	P27/ANI7 pin
0	0	1	0	0	0	ANI8	P150/ANI8 pin
0	0	1	0	0	1	ANI9	P151/ANI9 pin
0	0	1	0	1	0	ANI10	P152/ANI10 pin
0	0	1	0	1	1	ANI11	P153/ANI11 pin
0	0	1	1	0	0	ANI12	P154/ANI12 pin
0	0	1	1	0	1	ANI13	P155/ANI13 pin
0	0	1	1	1	0	ANI14	P156/ANI14 pin
0	0	1	1	1	1	Setting prohibited	
0	1	0	0	0	0	ANI16	P03/ANI16 pin ^{Note 1}
0	1	0	0	0	1	ANI17	P02/ANI17 pin ^{Note 2}
0	1	0	0	1	0	ANI18	P147/ANI18 pin
0	1	0	0	1	1	ANI19	P120/ANI19 pin
0	1	0	1	0	0	ANI20	P100/ANI20 pin
0	1	0	1	0	1	ANI21	P37/ANI21 pin
0	1	0	1	1	0	ANI22	P36/ANI22 pin
0	1	0	1	1	1	ANI23	P35/ANI23 pin
0	1	1	0	0	0	ANI24	P117/ANI24 pin
0	1	1	0	0	1	ANI25	P116/ANI25 pin
0	1	1	0	1	0	ANI26	P115/ANI26 pin
0	1	1	0	1	1	Setting prohibited	
1	0	0	0	0	0	–	Temperature sensor output voltage ^{Note 3}
1	0	0	0	0	1	–	Internal reference voltage output (1.45 V) ^{Note 3}
Other than the above						Setting prohibited	

(Notes and cautions are listed on the next page.)

- Notes**
1. 20-, 24-, 25-, 30-, 32-pin products: P01/ANI16 pin
 2. 20-, 24-, 25-, 30-, 32-pin products: P00/ANI17 pin
 3. This setting can be used only in HS (high-speed main) mode.

- Cautions**
1. Be sure to clear bits 5 and 6 to 0.
 2. Select input mode for the ports which are set to analog input with the ADPC and PMC registers, using the port mode registers 0, 2, 3, 10 to 12, 14, and 15 (PM0, PM2, PM3, PM10 to PM12, PM14, and PM15).
 3. Do not use the ADS register to set the pins which should be set as digital I/O with the A/D port configuration register (ADPC).
 4. Do not use the ADS register to set the pins which should be set as digital I/O with the port mode control registers 0, 3, 10 to 12, and 14 (PMC0, PMC3, PMC10 to PMC12, and PMC14).
 5. Only rewrite the value of the ADISS bit while conversion operation is stopped (ADCS = 0, ADCE = 0).
 6. If using AV_{REFP} as the positive reference voltage source of the A/D converter, do not select ANI0 as an A/D conversion channel.
 7. If using AV_{REFM} as the negative reference voltage source of the A/D converter, do not select ANI1 as an A/D conversion channel.
 8. When ADISS is 1, the internal reference voltage (1.45 V) cannot be used for the positive reference voltage. In addition, the first conversion result obtained after setting ADISS to 1 is not available. For detailed setting flow, see 11.7.4 Setup when temperature sensor output voltage/internal reference voltage is selected (example for software trigger mode and one-shot conversion mode).
 9. If a transition is made to STOP mode or a transition is made to HALT mode during CPU operation with subsystem clock, do not set ADISS to 1. When ADISS is 1, the A/D converter reference voltage current (I_{ADREF}) shown in 29.3.2 Supply current characteristics is added.

CHAPTER 23 REGULATOR

23.1 Regulator Overview

The RL78/G13 contains a circuit for operating the device with a constant voltage. At this time, in order to stabilize the regulator output voltage, connect the REGC pin to V_{SS} via a capacitor (0.47 to 1 μF). Also, use a capacitor with good characteristics, since it is used to stabilize internal voltage.

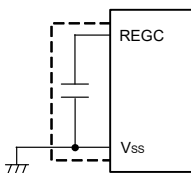

Caution Keep the wiring length as short as possible for the broken-line part in the above figure.

The regulator output voltage, see table 23-1.

Table 23-1. Regulator Output Voltage Conditions

Mode	Output Voltage	Condition
LV (low voltage main) mode	1.8 V	-
LS (low-speed main) mode		
HS (high-speed main) mode	1.8 V	In STOP mode
		When both the high-speed system clock (f _{MX}) and the high-speed on-chip oscillator clock (f _{IH}) are stopped during CPU operation with the subsystem clock (f _{SUB})
	When both the high-speed system clock (f _{MX}) and the high-speed on-chip oscillator clock (f _{IH}) are stopped during the HALT mode when the CPU operation with the subsystem clock (f _{SUB}) has been set	
	2.1 V	Other than above (include during OCD mode) ^{Note}

Note When it shifts to the subsystem clock operation or STOP mode during the on-chip debugging, the regulator output voltage is kept at 2.1 V (not decline to 1.8 V).

CHAPTER 24 OPTION BYTE

24.1 Functions of Option Bytes

Addresses 000C0H to 000C3H of the flash memory of the RL78/G13 form an option byte area.

Option bytes consist of user option byte (000C0H to 000C2H) and on-chip debug option byte (000C3H).

Upon power application or resetting and starting, an option byte is automatically referenced and a specified function is set. When using the product, be sure to set the following functions by using the option bytes.

For the bits to which no function is allocated, do not change their initial values.

To use the boot swap operation during self programming, 000C0H to 000C3H are replaced by 010C0H to 010C3H. Therefore, set the same values as 000C0H to 000C3H to 010C0H to 010C3H.

Remark The option bytes should always be set regardless of whether each function is used.

24.1.1 User option byte (000C0H to 000C2H/010C0H to 010C2H)

(1) 000C0H/010C0H

- Setting of watchdog timer operation
 - Enabling or disabling of counter operation
 - Enabling or disabling of counter operation in the HALT or STOP mode
- Setting of interval time of watchdog timer
- Setting of window open period of watchdog timer
- Setting of interval interrupt of watchdog timer
 - Whether or not to use the interval interrupt is selectable.

Caution Set the same value as 000C0H to 010C0H when the boot swap operation is used because 000C0H is replaced by 010C0H.

(2) 000C1H/010C1H

- Setting of LVD operation mode
 - Interrupt & reset mode.
 - Reset mode.
 - Interrupt mode.
 - LVD off (by controlling the externally input reset signal on the RESET pin)
- Setting of LVD detection level (V_{LVDH} , V_{LVDL} , V_{LVD})

Cautions 1. After power is supplied, the reset state must be retained until the operating voltage becomes in the range defined in 29.4 or 30.4 AC Characteristics. This is done by utilizing the voltage detection circuit or controlling the externally input reset signal. After the power supply is turned off, this LSI should be placed in the STOP mode, or placed in the reset state by utilizing the voltage detection circuit or controlling the externally input reset signal, before the voltage falls below the operating range. The range of operating voltage varies with the setting of the user option byte (000C2H or 010C2H).

2. Set the same value as 000C1H to 010C1H when the boot swap operation is used because 000C1H is replaced by 010C1H.

(3) 000C2H/010C2H

O Setting of flash operation mode

Make the setting depending on the main system clock frequency (f_{MAIN}) and power supply voltage (V_{DD}) to be used.

- LV (low voltage main) mode
- LS (low speed main) mode
- HS (high speed main) mode

O Setting of the frequency of the high-speed on-chip oscillator

- Select from 32 MHz/24 MHz/16 MHz/12 MHz/8 MHz/6 MHz/4 MHz /3 MHz/2 MHz/1 MHz (TYP.).

Caution Set the same value as 000C2H to 010C2H when the boot swap operation is used because 000C2H is replaced by 010C2H.

24.1.2 On-chip debug option byte (000C3H/010C3H)

O Control of on-chip debug operation

- On-chip debug operation is disabled or enabled.

O Handling of data of flash memory in case of failure in on-chip debug security ID authentication

- Data of flash memory is erased or not erased in case of failure in on-chip debug security ID authentication.

Caution Set the same value as 000C3H to 010C3H when the boot swap operation is used because 000C3H is replaced by 010C3H.

24.2 Format of User Option Byte

The format of user option byte is shown below.

Figure 24-1. Format of User Option Byte (000C0H/010C0H)

Address: 000C0H/010C0H ^{Note 1}

	7	6	5	4	3	2	1	0
	WDTINIT	WINDOW1	WINDOW0	WDTON	WDCS2	WDCS1	WDCS0	WDSTBYON

WDTINIT	Use of interval interrupt of watchdog timer		
0	Interval interrupt is not used.		
1	Interval interrupt is generated when 75% of the overflow time + 1/2 f _{IL} is reached.		

WINDOW1	WINDOW0	Watchdog timer window open period ^{Note 2}	
0	0	Setting prohibited	
0	1	50%	
1	0	75% ^{Note 3}	
1	1	100%	

WDTON	Operation control of watchdog timer counter		
0	Counter operation disabled (counting stopped after reset)		
1	Counter operation enabled (counting started after reset)		

WDCS2	WDCS1	WDCS0	Watchdog timer overflow time (f _{IL} = 17.25 kHz (MAX.))
0	0	0	2 ⁶ /f _{IL} (3.71 ms)
0	0	1	2 ⁷ /f _{IL} (7.42 ms)
0	1	0	2 ⁸ /f _{IL} (14.84 ms)
0	1	1	2 ⁹ /f _{IL} (29.68 ms)
1	0	0	2 ¹¹ /f _{IL} (118.72 ms)
1	0	1	2 ¹³ /f _{IL} (474.89 ms)
1	1	0	2 ¹⁴ /f _{IL} (949.79 ms)
1	1	1	2 ¹⁶ /f _{IL} (3799.18 ms)

WDSTBYON	Operation control of watchdog timer counter (HALT/STOP mode)		
0	Counter operation stopped in HALT/STOP mode ^{Note 2}		
1	Counter operation enabled in HALT/STOP mode		

- Notes**
1. Set the same value as 000C0H to 010C0H when the boot swap operation is used because 000C0H is replaced by 010C0H.
 2. The window open period is 100% when WDSTBYON = 0, regardless the value of the WINDOW1 and WINDOW0 bits.

3. When the window open period is set to 75%, clearing the counter of the watchdog timer (writing ACH to WDTE) must proceed outside the corresponding period from among those listed below, over which clearing of the counter is prohibited (for example, confirming that the interval timer interrupt request flag (WDTIIF) of the watchdog timer is set).

WDCS2	WDCS1	WDCS0	Watchdog timer overflow time ($f_{IL} = 17.25 \text{ kHz (MAX.)}$)	Period over which clearing the counter is prohibited when the window open period is set to 75%
0	0	0	$2^6/f_{IL}$ (3.71 ms)	1.85 ms to 2.51 ms
0	0	1	$2^7/f_{IL}$ (7.42 ms)	3.71 ms to 5.02 ms
0	1	0	$2^8/f_{IL}$ (14.84 ms)	7.42 ms to 10.04 ms
0	1	1	$2^9/f_{IL}$ (29.68 ms)	14.84 ms to 20.08 ms
1	0	0	$2^{11}/f_{IL}$ (118.72 ms)	56.36 ms to 80.32 ms
1	0	1	$2^{13}/f_{IL}$ (474.89 ms)	237.44 ms to 321.26 ms
1	1	0	$2^{14}/f_{IL}$ (949.79 ms)	474.89 ms to 642.51 ms
1	1	1	$2^{16}/f_{IL}$ (3799.18 ms)	1899.59 ms to 2570.04 ms

Remark f_{IL} : Low-speed on-chip oscillator clock frequency

Figure 24-2. Format of User Option Byte (000C1H/010C1H) (1/2)

Address: 000C1H/010C1H^{Note}

	7	6	5	4	3	2	1	0
	VPOC2	VPOC1	VPOC0	1	LVIS1	LVIS0	LVIMDS1	LVIMDS0

• LVD setting (interrupt & reset mode)

Detection voltage			Option byte setting value						
V _{LV_{DH}}		V _{LV_{DL}}	VPOC2	VPOC1	VPOC0	LVIS1	LVIS0	Mode setting	
Rising edge	Falling edge	Falling edge						LVIMDS1	LVIMDS0
1.77 V	1.73 V	1.63 V	0	0	0	1	0	1	0
1.88 V	1.84 V					0	1		
2.92 V	2.86 V					0	0		
1.98 V	1.94 V	1.84 V		0	1	1	0		
2.09 V	2.04 V					0	1		
3.13 V	3.06 V					0	0		
2.61 V	2.55 V	2.45 V		1	0	1	0		
2.71 V	2.65 V					0	1		
3.75 V	3.67 V					0	0		
2.92 V	2.86 V	2.75 V	1	1	1	0			
3.02 V	2.96 V				0	1			
4.06 V	3.98 V				0	0			
-			Setting of values other than above is prohibited.						

• LVD setting (reset mode)

Detection voltage		Option byte setting value						
V _{LV_D}		VPOC2	VPOC1	VPOC0	LVIS1	LVIS0	Mode setting	
Rising edge	Falling edge						LVIMDS1	LVIMDS0
1.67 V	1.63 V	0	0	0	1	1	1	1
1.77 V	1.73 V		0	0	1	0		
1.88 V	1.84 V		0	1	1	1		
1.98 V	1.94 V		0	1	1	0		
2.09 V	2.04 V		0	1	0	1		
2.50 V	2.45 V		1	0	1	1		
2.61 V	2.55 V		1	0	1	0		
2.71 V	2.65 V		1	0	0	1		
2.81 V	2.75 V		1	1	1	1		
2.92 V	2.86 V		1	1	1	0		
3.02 V	2.96 V		1	1	0	1		
3.13 V	3.06 V		0	1	0	0		
3.75 V	3.67 V		1	0	0	0		
4.06 V	3.98 V		1	1	0	0		
-			Setting of values other than above is prohibited.					

Note Set the same value as 000C1H to 010C1H when the boot swap operation is used because 000C1H is replaced by 010C1H.

Remarks 1. For details on the LVD circuit, see **CHAPTER 21 VOLTAGE DETECTOR**.

2. The detection voltage is a typical value. For details, see **29.6.4** or **30.6.4 LVD circuit characteristics**.

(Cautions are listed on the next page.)

Figure 24-2. Format of User Option Byte (000C1H/010C1H) (2/2)

Address: 000C1H/010C1H^{Note}

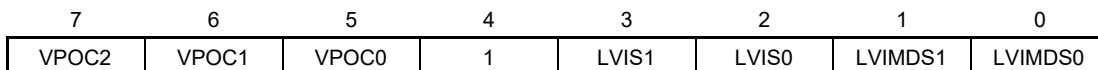

• LVD setting (interrupt mode)

Detection voltage		Option byte setting value									
V _{LVD}		VPOC2	VPOC1	VPOC0	LVIS1	LVIS0	Mode setting				
Rising edge	Falling edge						LVIMDS1	LVIMDS0			
1.67 V	1.63 V	0	0	0	1	1	0	1			
1.77 V	1.73 V		0	0	1	0					
1.88 V	1.84 V		0	1	1	1					
1.98 V	1.94 V		0	1	1	0					
2.09 V	2.04 V		0	1	0	1					
2.50 V	2.45 V		1	0	1	1					
2.61 V	2.55 V		1	0	1	0					
2.71 V	2.65 V		1	0	0	1					
2.81 V	2.75 V		1	1	1	1					
2.92 V	2.86 V		1	1	1	0					
3.02 V	2.96 V		1	1	0	1					
3.13 V	3.06 V		0	1	0	0					
3.75 V	3.67 V		1	0	0	0					
4.06 V	3.98 V		1	1	0	0					
–			Setting of values other than above is prohibited.								

• LVD off (by controlling the externally input reset signal on the $\overline{\text{RESET}}$ pin)

Detection voltage		Option byte setting value						
V _{LVD}		VPOC2	VPOC1	VPOC0	LVIS1	LVIS0	Mode setting	
Rising edge	Falling edge						LVIMDS1	LVIMDS0
–	–	1	×	×	×	×	×	1
–		Setting of values other than above is prohibited.						

Note Set the same value as 000C1H to 010C1H when the boot swap operation is used because 000C1H is replaced by 010C1H.

Cautions 1. Be sure to set bit 4 to “1”.

2. After power is supplied, the reset state must be retained until the operating voltage becomes in the range defined in 29.4 or 30.4 AC Characteristics. This is done by utilizing the voltage detection circuit or controlling the externally input reset signal. After the power supply is turned off, this LSI should be placed in the STOP mode, or placed in the reset state by utilizing the voltage detection circuit or controlling the externally input reset signal, before the voltage falls below the operating range. The range of operating voltage varies with the setting of the user option byte (000C2H or 010C2H).

Remarks 1. ×: don't care

2. For details on the LVD circuit, see CHAPTER 21 VOLTAGE DETECTOR.

3. The detection voltage is a typical value. For details, see 29.6.4 or 30.6.4 LVD circuit characteristics.

Figure 24-3. Format of Option Byte (000C2H/010C2H)

Address: 000C2H/010C2H^{Note}

7	6	5	4	3	2	1	0
CMODE1	CMODE0	1	0	FRQSEL3	FRQSEL2	FRQSEL1	FRQSEL0

CMODE1	CMODE0	Setting of flash operation mode		
			Operating Frequency Range (f _{MAIN})	Operating Voltage Range (V _{DD})
0	0	LV (low voltage main) mode	1 to 4 MHz	1.6 to 5.5 V
1	0	LS (low speed main) mode	1 to 8 MHz	1.8 to 5.5 V
1	1	HS (high speed main) mode	1 to 16 MHz	2.4 to 5.5 V
			1 to 32 MHz	2.7 to 5.5 V
Other than above		Setting prohibited		

FRQSEL3	FRQSEL2	FRQSEL1	FRQSEL0	Frequency of the high-speed on-chip oscillator
1	0	0	0	32 MHz
0	0	0	0	24 MHz
1	0	0	1	16 MHz
0	0	0	1	12 MHz
1	0	1	0	8 MHz
0	0	1	0	6 MHz
1	0	1	1	4 MHz
0	0	1	1	3 MHz
1	1	0	0	2 MHz
1	1	0	1	1 MHz
Other than above				Setting prohibited

Note Set the same value as 000C2H to 010C2H when the boot swap operation is used because 000C2H is replaced by 010C2H.

- Cautions**
1. Be sure to set bit 5 to “1” and bit 4 to “0”
 2. The ranges of operation frequency and operation voltage vary depending on the flash operation mode. For details, see 29.4 or 30.4 AC Characteristics.

24.3 Format of On-chip Debug Option Byte

The format of on-chip debug option byte is shown below.

Figure 24-4. Format of On-chip Debug Option Byte (000C3H/010C3H)

Address: 000C3H/010C3H^{Note}

7	6	5	4	3	2	1	0
OCDENSET	0	0	0	0	1	0	OCDERSD

OCDENSET	OCDERSD	Control of on-chip debug operation
0	0	Disables on-chip debug operation.
0	1	Setting prohibited
1	0	Enables on-chip debugging. Erases data of flash memory in case of failures in authenticating on-chip debug security ID.
1	1	Enables on-chip debugging. Does not erases data of flash memory in case of failures in authenticating on-chip debug security ID.

Note Set the same value as 000C3H to 010C3H when the boot swap operation is used because 000C3H is replaced by 010C3H.

Caution Bits 7 and 0 (OCDENSET and OCDERSD) can only be specified a value.
Be sure to set 000010B to bits 6 to 1.

Remark The value on bits 3 to 1 will be written over when the on-chip debug function is in use and thus it will become unstable after the setting.
However, be sure to set the default values (0, 1, and 0) to bits 3 to 1 at setting.

24.4 Setting of Option Byte

The user option byte and on-chip debug option byte can be set using the link option, in addition to describing to the source. When doing so, the contents set by using the link option take precedence, even if descriptions exist in the source, as mentioned below.

A software description example of the option byte setting is shown below.

OPT	CSEG	OPT_BYTE	
	DB	36H	; Does not use interval interrupt of watchdog timer, ; Enables watchdog timer operation, ; Window open period of watchdog timer is 50%, ; Overflow time of watchdog timer is $2^9/f_{IL}$, ; Stops watchdog timer operation during HALT/STOP mode
	DB	1AH	; Select 1.63 V for V_{LVDL} ; Select rising edge 1.77 V, falling edge 1.73 V for V_{LVDH} ; Select the interrupt & reset mode as the LVD operation mode
	DB	2DH	; Select the LV (low voltage main) mode as the flash operation mode ; and 1 MHz as the frequency of the high-speed on-chip oscillator
	DB	85H	; Enables on-chip debug operation, does not erase flash memory ; data when security ID authorization fails

When the boot swap function is used during self programming, 000C0H to 000C3H is switched to 010C0H to 010C3H. Describe to 010C0H to 010C3H, therefore, the same values as 000C0H to 000C3H as follows.

OPT2	CSEG	AT	010C0H	
	DB		36H	; Does not use interval interrupt of watchdog timer, ; Enables watchdog timer operation, ; Window open period of watchdog timer is 50%, ; Overflow time of watchdog timer is $2^9/f_{IL}$, ; Stops watchdog timer operation during HALT/STOP mode
	DB		1AH	; Select 1.63 V for V_{LVDL} ; Select rising edge 1.77 V, falling edge 1.73 V for V_{LVDH} ; Select the interrupt & reset mode as the LVD operation mode
	DB		2DH	; Select the LV (low main voltage) mode as the flash operation mode ; and 1 MHz as the frequency of the high-speed on-chip oscillator
	DB		85H	; Enables on-chip debug operation, does not erase flash memory ; data when security ID authorization fails

Caution To specify the option byte by using assembly language, use `OPT_BYTE` as the relocation attribute name of the `CSEG` pseudo instruction. To specify the option byte to 010C0H to 010C3H in order to use the boot swap function, use the relocation attribute `AT` to specify an absolute address.

CHAPTER 25 FLASH MEMORY

The RL78 microcontroller incorporates the flash memory to which a program can be written, erased, and overwritten while mounted on the board. The flash memory includes the “code flash memory”, in which programs can be executed, and the “data flash memory”, an area for storing data.

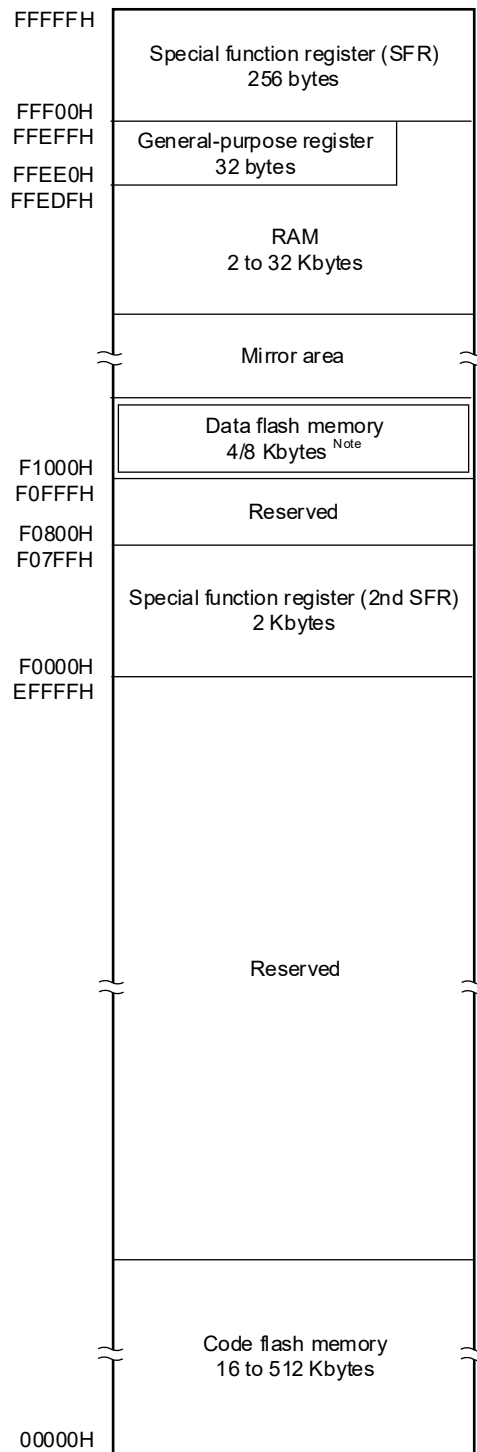

Note This area is reserved in the R5F101 products.

The following methods for programming the flash memory are available.

The code flash memory can be rewritten to through serial programming using a flash memory programmer or an external device (UART communication), or through self-programming.

- Serial programming using flash memory programmer (see **25.4**)

Data can be written to the flash memory on-board or off-board by using a dedicated flash memory programmer.

- Serial programming using external device (UART communication) (see **25.2**)

Data can be written to the flash memory on-board through UART communication with an external device (microcontroller or ASIC).

- Self-programming (see **25.6**)

The user application can execute self-programming of the code flash memory by using the flash self-programming library.

The data flash memory can be rewritten to by using the data flash library during user program execution (background operation). For access and writing to the data flash memory, see **25.8 Data Flash**.

25.1 Serial Programming Using Flash Memory Programmer

The following dedicated flash memory programmer can be used to write data to the internal flash memory of the RL78 microcontroller.

- PG-FP5, PG-FP6
- E1, E2, E2 Lite, E20 on-chip debugging emulator

Data can be written to the flash memory on-board or off-board, by using a dedicated flash memory programmer.

(1) On-board programming

The contents of the flash memory can be rewritten after the RL78 microcontroller has been mounted on the target system. The connectors that connect the dedicated flash memory programmer must be mounted on the target system.

(2) Off-board programming

Data can be written to the flash memory with a dedicated program adapter before the RL78 microcontroller is mounted on the target system.

Table 25-1. Wiring between RL78/G13 and Dedicated Flash Memory Programmer

Pin Configuration of Dedicated Flash Memory Programmer				Pin Name	Pin No.							
Signal Name		I/O	Pin Function		20-pin	24-pin	25-pin	30-pin	32-pin	36-pin	40-pin	44-pin
PG-FP5, PG-FP6	E1, E2, E2 Lite, E20 on-chip debugging emulator			SSOP	WQFN (4x4)	FLGA (3x3)	SSOP	WQFN (5x5)	FLGA (4x4)	WQFN (6x6)	LQFP (10x10)	
–	TOOL0	I/O	Transmit/receive signal	TOOL0/P40	3	23	A5	5	1	F6	1	2
SI/RxD	–	I/O	Transmit/receive signal									
–	RESET	Output	Reset signal	RESET	4	24	B5	6	2	E5	2	3
/RESET	–	Output										
V _{DD} ^{Note 1}		I/O	V _{DD} voltage generation/power monitoring	V _{DD}	10	6	B3	12	8	B6	10	11
GND		–	Ground	V _{SS}	9	5	B2	11	7	C5	9	10
				REGC ^{Note 2}	8	4	A2	10	6	D5	8	9
FLMD1	EMV _{DD}	–	Driving power for TOOL0 pin	V _{DD}	10	6	B3	12	8	B6	10	11

Pin Configuration of Dedicated Flash Memory Programmer				Pin Name	Pin No.							
Signal Name		I/O	Pin Function		48-pin	52-pin	64-pin		80-pin	100-pin		128-pin
PG-FP5, PG-FP6	E1, E2, E2 Lite, E20 on-chip debugging emulator			LQFP (7x7), WQFN (7x7)	LQFP (10x10)	LQFP (12x12), LQFP (10x10)	FBGA (4x4)	LQFP (14x14), LQFP (12x12)	LQFP (14x14)	LQFP (14x20)	LQFP (14x20)	
–	TOOL0	I/O	Transmit/receive signal	TOOL0/P40	39	4	5	D6	9	12	89	22
SI/RxD	–	I/O	Transmit/receive signal									
–	RESET	Output	Reset signal	RESET	40	5	6	E7	10	13	90	26
/RESET	–	Output										
V _{DD} ^{Note 1}		I/O	V _{DD} voltage generation/power monitoring	V _{DD}	48	13	15	B7	19	22	99	35
GND		–	Ground	V _{SS}	47	12	13	C7	17	20	97	33
				EV _{SS}	–	–	14	B8	18	21, 43	98, 20	34, 56
				REGC ^{Note 2}	46	11	12	D7	16	19	96	32
FLMD1	EMV _{DD}	–	Driving power for TOOL0 pin	V _{DD}	48	13	–	–	–	–	–	–
				EV _{DD}	–	–	16	A8	20	23, 53	100, 30	36, 57

Notes 1. The name of the signal for connection in the case of the PG-FP6 is V_{CC}.

2. Connect REGC pin to ground via a capacitor (0.47 to 1 μF).

Remark Pins that are not indicated in the above table can be left open when using the flash memory programmer for flash programming.

25.1.1 Programming environment

The environment required for writing a program to the flash memory of the RL78 microcontroller is illustrated below.

Figure 25-1. Environment for Writing Program to Flash Memory

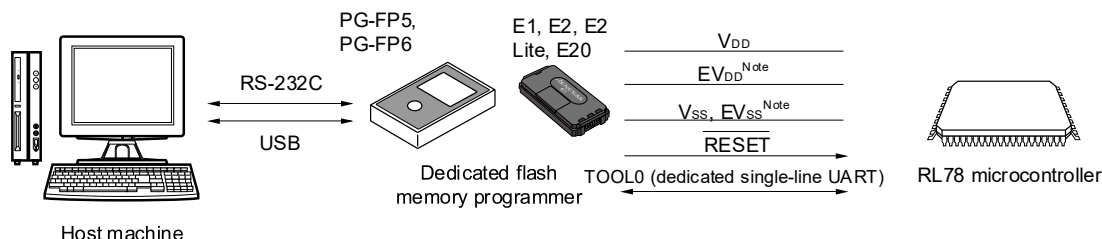

Note 64-pin, 80-pin, 100-pin and 128-pin products only.

A host machine that controls the dedicated flash memory programmer is necessary.

To interface between the dedicated flash memory programmer and the RL78 microcontroller, the TOOL0 pin is used for manipulation such as writing and erasing via a dedicated single-line UART.

25.1.2 Communication mode

Communication between the dedicated flash memory programmer and the RL78 microcontroller is established by serial communication using the TOOL0 pin via a dedicated single-line UART of the RL78 microcontroller.

Transfer rate: 1 M, 500 k, 250 k, 115.2 kbps

Figure 25-2. Communication with Dedicated Flash Memory Programmer

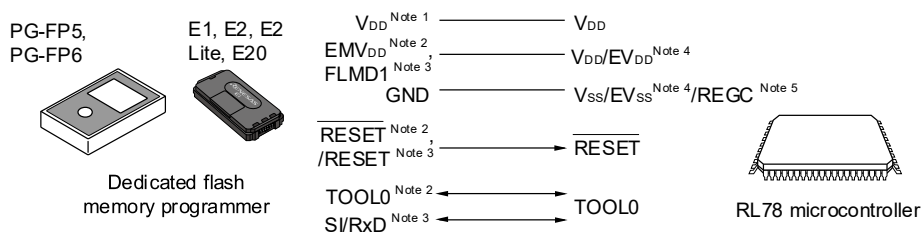

- Notes**
1. The name of the signal for connection in the case of the PG-FP6 is Vcc.
 2. When using E1, E2, E2 Lite, E20 on-chip debugging emulator.
 3. When using PG-FP5 or PG-FP6.
 4. 64-pin, 80-pin, 100-pin and 128-pin products only.
 5. Connect REGC pin to ground via a capacitor (0.47 to 1 μF).

The dedicated flash memory programmer generates the following signals for the RL78 microcontroller. See each manual of PG-FP5, PG-FP6, or E1, E2, E2 Lite, E20 on-chip debugging emulator for details.

Table 25-2. Pin Connection

Dedicated Flash Memory Programmer			RL78 Microcontroller	
Signal Name		I/O	Pin Function	Pin Name ^{Note 1}
PG-FP5, PG-FP6	E1, E2, E2 Lite, E20 on-chip debugging emulator			
V _{DD} ^{Note 2}		I/O	V _{DD} voltage generation/power monitoring	V _{DD}
GND		–	Ground	V _{SS} , EV _{SS} , REGC ^{Note 3}
FLMD1	EMV _{DD}	–	Driving power for TOOL0 pin	V _{DD} , EV _{DD}
/RESET	–	Output	Reset signal	RESET
–	RESET	Output		
–	TOOL0	I/O	Transmit/receive signal	TOOL0
SI/RxD	–	I/O	Transmit/receive signal	

- Notes**
1. Pins to be connected differ with the product. For details, see **Table 25-1**.
 2. The name of the signal for connection in the case of the PG-FP6 is V_{CC}.
 3. Connect REGC pin to ground via a capacitor (0.47 to 1 μF).

25.2 Serial Programming Using External Device (that Incorporates UART)

On-board data writing to the internal flash memory is possible by using the RL78 microcontroller and an external device (a microcontroller or ASIC) connected to a UART.

For the development of flash memory programmer by user, refer to **RL78 Microcontrollers (RL78 Protocol A) Programmer Edition Application Note (R01AN0815)**.

25.2.1 Programming environment

The environment required for writing a program to the flash memory of the RL78 microcontroller is illustrated below.

Figure 25-3. Environment for Writing Program to Flash Memory

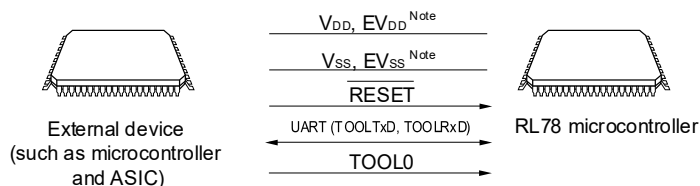

Note 64-pin, 80-pin, 100-pin and 128-pin products only.

Processing to write data to or erase data from the RL78 microcontroller by using an external device is performed on-board. Off-board writing is not possible.

25.2.2 Communication mode

Communication between the external device and the RL78 microcontroller is established by serial communication using the TOOLTxD and TOOLRxD pins via the dedicated UART of the RL78 microcontroller.

Transfer rate: 1 M, 500 k, 250 k, 115.2kbps

Figure 25-4. Communication with External Device

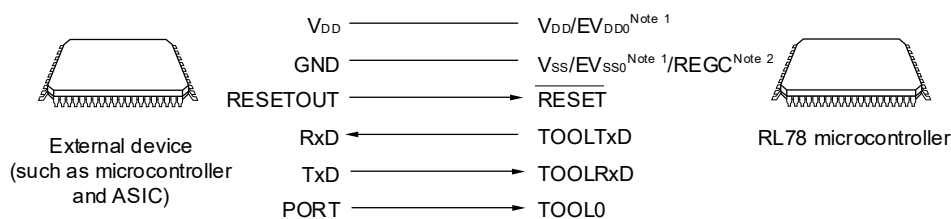

- Notes 1.** 64-pin, 80-pin, 100-pin and 128-pin products only.
- 2.** Connect REGC pin to ground via a capacitor (0.47 to 1 μ F).

The external device generates the following signals for the RL78 microcontroller.

Table 25-3. Pin Connection

External Device			RL78 Microcontroller
Signal Name	I/O	Pin Function	Pin Name
V _{DD}	I/O	V _{DD} voltage generation/power monitoring	V _{DD} , EV _{DD0}
GND	–	Ground	V _{SS} , EV _{SS} , REGC Note
RESETOUT	Output	Reset signal output	RESET
RxD	Input	Receive signal	TOOLTxD
TxD	Output	Transmit signal	TOOLRxD
PORT	Output	Mode signal	TOOL0

Note Connect REGC pin to ground via a capacitor (0.47 to 1 μ F).

25.3 Connection of Pins on Board

To write the flash memory on-board by using the flash memory programmer, connectors that connect the dedicated flash memory programmer must be provided on the target system. First provide a function that selects the normal operation mode or flash memory programming mode on the board.

When the flash memory programming mode is set, all the pins not used for programming the flash memory are in the same status as immediately after reset. Therefore, if the external device does not recognize the state immediately after reset, the pins must be handled as described below.

Remark For the flash memory programming mode, see **25.4.2 Flash memory programming mode**.

25.3.1 P40/TOOL0 pin

In the flash memory programming mode, connect this pin to the dedicated flash memory programmer via an external 1 k Ω pull-up resistor.

When this pin is used as the port pin, use that by the following method.

When used as an input pin: Input of low-level is prohibited for t_{HD} period after external pin reset release. However, when this pin is used via pull-down resistors, use the 500 k Ω or more resistors.

When used as an output pin: When this pin is used via pull-down resistors, use the 500 k Ω or more resistors.

- Remarks**
1. t_{HD} : How long to keep the TOOL0 pin at the low level from when the external and internal resets end for setting of the flash memory programming mode (see **29.10** or **30.10 Timing of Entry to Flash Memory Programming Modes**)
 2. The SAU and IICA pins are not used for communication between the RL78 microcontroller and dedicated flash memory programmer, because single-line UART (TOOL0 pin) is used.

25.3.2 $\overline{\text{RESET}}$ pin

Signal conflict will occur if the reset signal of the dedicated flash memory programmer and external device are connected to the $\overline{\text{RESET}}$ pin that is connected to the reset signal generator on the board. To prevent this conflict, isolate the connection with the reset signal generator.

The flash memory will not be correctly programmed if the reset signal is input from the user system while the flash memory programming mode is set. Do not input any signal other than the reset signal of the dedicated flash memory programmer and external device.

Figure 25-5. Signal Conflict ($\overline{\text{RESET}}$ Pin)

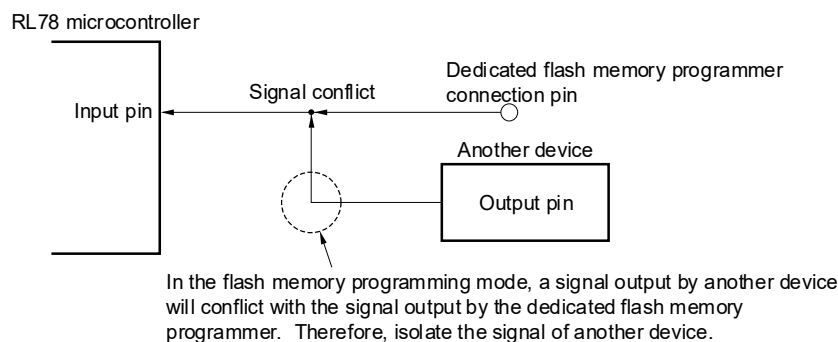

25.3.3 Port pins

When the flash memory programming mode is set, all the pins not used for flash memory programming enter the same status as that immediately after reset. If external devices connected to the ports do not recognize the port status immediately after reset, the port pin must be connected to either V_{DD} or EV_{DD0}/EV_{DD1} , or V_{SS} or EV_{SS0}/EV_{SS1} , via a resistor.

25.3.4 REGC pin

Connect the REGC pin to GND via a capacitor having excellent characteristics (0.47 to 1 μ F) in the same manner as during normal operation. Also, use a capacitor with good characteristics, since it is used to stabilize internal voltage.

25.3.5 X1 and X2 pins

Connect X1 and X2 in the same status as in the normal operation mode.

Remark In the flash memory programming mode, the high-speed on-chip oscillator clock (f_{IH}) is used.

25.3.6 Power supply

To use the supply voltage output of the flash memory programmer, connect the V_{DD} pin to V_{DD} ^{Note} of the flash memory programmer, and the V_{SS} pin to GND of the flash memory programmer.

To use the on-board supply voltage, connect in compliance with the normal operation mode.

However, when writing to the flash memory by using the flash memory programmer and using the on-board supply voltage, be sure to connect the V_{DD} and V_{SS} pins to V_{DD} ^{Note} and GND of the flash memory programmer to use the power monitor function with the flash memory programmer.

Note The name of the signal for connection in the case of the PG-FP6 is V_{CC} .

25.4 Serial Programming Method

25.4.1 Serial programming procedure

The following figure illustrates a flow for rewriting the code flash memory through serial programming.

Figure 25-6. Code Flash Memory Manipulation Procedure

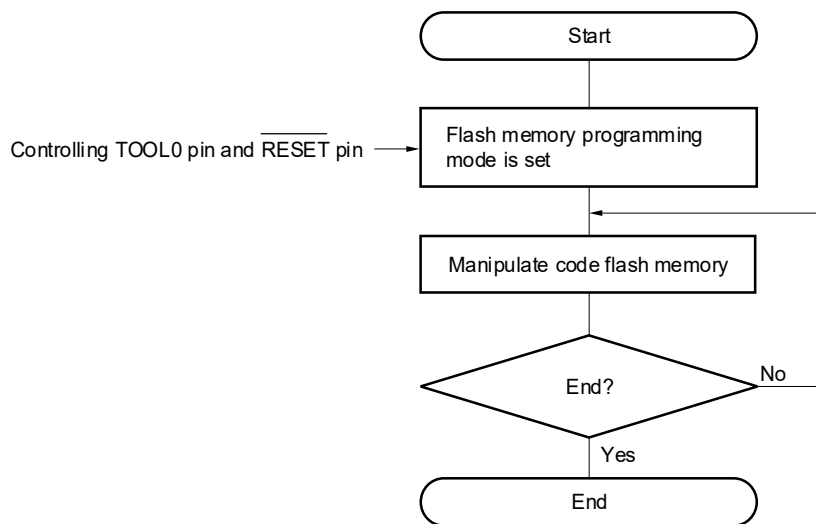

25.4.2 Flash memory programming mode

To rewrite the contents of the code flash memory through serial programming, specify the flash memory programming mode. To enter the mode, set as follows.

<Serial programming using the dedicated flash memory programmer>

Connect the RL78 microcontroller to a dedicated flash memory programmer. Communication from the dedicated flash memory programmer is performed to automatically switch to the flash memory programming mode.

<Serial programming using an external device (UART communication)>

Set the TOOL0 pin to the low level, and then cancel the reset (see **Table 25-4**). After that, enter flash memory programming mode according to the procedures <1> to <4> shown in **Figure 25-7**. For details, refer to **RL78 Microcontrollers (RL78 Protocol A) Programmer Edition Application Note (R01AN0815)**.

Table 25-4. Relationship between TOOL0 Pin and Operation Mode after Reset Release

TOOL0	Operation Mode
EV _{DD}	Normal operation mode
0 V	Flash memory programming mode

Figure 25-7. Setting of Flash Memory Programming Mode

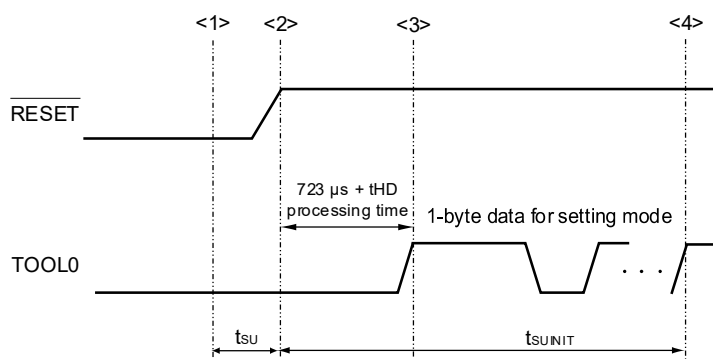

- <1> The low level is input to the TOOL0 pin.
- <2> The external reset ends (POR and LVD reset must end before the external reset ends.).
- <3> The TOOL0 pin is set to the high level.
- <4> Baud rate setting by UART reception is completed.

Remark t_{SUNIT} : The segment shows that it is necessary to finish specifying the initial communication settings within 100 ms from when the resets end.

t_{SU} : How long from when the TOOL0 pin is placed at the low level until an external reset ends

t_{HD} : How long to keep the TOOL0 pin at the low level from when the external and internal resets end (the flash firmware processing time is excluded)

For details, see **29.10** or **30.10 Timing of Entry to Flash Memory Programming Modes**.

There are two flash memory programming modes: wide voltage mode and full speed mode. The supply voltage value applied to the microcontroller during write operations and the setting information of the user option byte for setting of the flash memory programming mode determine which mode is selected.

When a dedicated flash memory programmer is used for serial programming, setting the voltage on GUI selects the mode automatically.

Table 25-5. Programming Modes and Voltages at Which Data Can Be Written, Erased, or Verified

Power Supply Voltage (V_{DD})	User Option Byte Setting for Switching to Flash Memory Programming Mode		Flash Programming Mode
	Flash Operation Mode	Operating Frequency	
$2.7\text{ V} \leq V_{DD} \leq 5.5\text{ V}$	Blank state		Full speed mode
	HS (high speed main) mode	1 MHz to 32 MHz	Full speed mode
	LS (low speed main) mode	1 MHz to 8 MHz	Wide voltage mode
	LV (low voltage main) mode	1 MHz to 4 MHz	Wide voltage mode
$2.4\text{ V} \leq V_{DD} < 2.7\text{ V}$	Blank state		Full speed mode
	HS (high speed main) mode	1 MHz to 16 MHz	Full speed mode
	LS (low speed main) mode	1 MHz to 8 MHz	Wide voltage mode
	LV (low voltage main) mode	1 MHz to 4 MHz	Wide voltage mode
$1.8\text{ V} \leq V_{DD} < 2.4\text{ V}$	Blank state		Wide voltage mode
	LS (low speed main) mode	1 MHz to 8 MHz	Wide voltage mode
	LV (low voltage main) mode	1 MHz to 4 MHz	Wide voltage mode

- Remarks**
- Using both the wide voltage mode and full speed mode imposes no restrictions on writing, erasing, or verification.
 - For details about communication commands, see **25.4.4 Communication commands**.

25.4.3 Selecting communication mode

Communication modes of the RL78 microcontroller are as follows.

Table 25-6. Communication Modes

Communication Mode	Standard Setting ^{Note 1}			Pins Used
	Port	Speed ^{Note 2}	Frequency	
1-line UART (when flash memory programmer is used, or when external device is used)	UART	115200 bps, 250000 bps, 500000 bps, 1 Mbps	–	TOOL0
Dedicated UART (when external device is used)	UART	115200 bps, 250000 bps, 500000 bps, 1 Mbps	–	TOOLTxD, TOOLRxD

- Notes**
1. Selection items for Standard settings on GUI of the flash memory programmer.
 2. Because factors other than the baud rate error, such as the signal waveform slew, also affect UART communication, thoroughly evaluate the slew as well as the baud rate error.

25.4.4 Communication commands

The RL78 microcontroller executes serial programming through the commands listed in **Table 25-7**.

The signals sent from the dedicated flash memory programmer or external device to the RL78 microcontroller are called commands, and programming functions corresponding to the commands are executed. For details, refer to **RL78 Microcontrollers (RL78 Protocol A) Programmer Edition Application Note (R01AN0815)**.

Table 25-7. Flash Memory Control Commands

Classification	Command Name	Function
Verify	Verify	Compares the contents of a specified area of the flash memory with data transmitted from the programmer.
Erase	Block Erase	Erases a specified area in the flash memory.
Blank check	Block Blank Check	Checks if a specified block in the flash memory has been correctly erased.
Write	Programming	Writes data to a specified area in the flash memory.
Getting information	Silicon Signature	Gets the RL78 microcontroller information (such as the part number, flash memory configuration, and programming firmware version).
	Checksum	Gets the checksum data for a specified area.
Security	Security Set	Sets security information.
	Security Get	Gets security information.
	Security Release	Release setting of prohibition of writing.
Others	Reset	Used to detect synchronization status of communication.
	Baud Rate Set	Sets baud rate when UART communication mode is selected.

Note Confirm that no data has been written to the write area. Because data cannot be erased after block erase is prohibited, do not write data if the data has not been erased.

Product information (such as product name and firmware version) can be obtained by executing the “Silicon Signature” command.

Table 25-8 is a list of signature data and **Table 25-9** shows an example of signature data.

Table 25-8. Signature Data List

Field name	Description	Number of transmit data
Device code	The serial number assigned to the device	3 bytes
Device name	Device name (ASCII code)	10 bytes
Code flash memory area last address	Last address of code flash memory area (Sent from lower address. Example: 00000H to 0FFFFH (64 KB) → FFH, FFH, 00H)	3 bytes
Data flash memory area last address	Last address of data flash memory area (Sent from lower address. Example: F1000H to F1FFFH (4 KB) → FFH, 1FH, 0FH)	3 bytes
Firmware version	Version information of firmware for programming (Sent from upper address. Example: From Ver. 1.23 → 01H, 02H, 03H)	3 bytes

Table 25-9. Example of Signature Data

Field name	Description	Number of transmit data	Data (hexadecimal)
Device code	RL78 protocol A	3 bytes	10 00 06
Device name	R5F100LE	10 bytes	52 = “R” 35 = “5” 46 = “F” 31 = “1” 30 = “0” 30 = “0” 4C = “L” 45 = “E” 20 = “ ” 20 = “ ”
Code flash memory area last address	Code flash memory area 00000H to 0FFFFH (64 KB)	3 bytes	FF FF 00
Data flash memory area last address	Data flash memory area F1000H to F1FFFH (4 KB)	3 bytes	FF 1F 0F
Firmware version	Ver.1.23	3 bytes	01 02 03

25.5 Processing Time for Each Command When Dedicated Flash Memory Programmer Is in Use (Reference Value)

The following tables show the processing time for each command (reference value) when PG-FP5 or PG-FP6 is used as a dedicated flash memory programmer.

Table 25-10. Processing Time for Each Command When PG-FP5 Is in Use (Reference Value)

PG-FP5 Command	Code Flash									
	16 Kbytes	32 Kbytes	48 Kbytes	64 Kbytes	96 Kbytes	128 Kbytes	192 Kbytes	256 Kbytes	384 Kbytes	512 Kbytes
Erasing	1 s	1 s	1 s	1.5 s	1.5 s	2 s	2 s	2.5 s	3 s	4 s
Writing	1.5 s	1.5 s	2 s	2.5 s	3 s	3.5 s	5 s	6 s	8.5 s	11 s
Verification	1.5 s	1.5 s	2 s	2 s	3 s	3.5 s	4.5 s	5.5 s	8 s	10.5 s
Writing after erasing	1.5 s	2 s	2.5 s	3 s	4 s	4.5 s	6.5 s	8 s	11 s	14.5 s

Remark The command processing times (reference values) shown in the table are typical values under the following conditions.

Port: TOOL0 (single-line UART)

Speed: 1,000,000 bps

Mode: Full speed mode (flash operation mode: HS (high speed main) mode)

Table 25-11. Processing Time for Each Command When PG-FP6 Is in Use (Reference Value)

PG-FP6 Command	Code Flash									
	16 Kbytes	32 Kbytes	48 Kbytes	64 Kbytes	96 Kbytes	128 Kbytes	192 Kbytes	256 Kbytes	384 Kbytes	512 Kbytes
Erasing	0.7 s	0.8 s	0.9 s	1.0 s	1.2 s	1.3 s	1.7 s	2.1 s	2.8 s	3.5 s
Writing	0.8 s	1.1 s	1.4 s	1.6 s	2.4 s	2.9 s	4.0 s	5.2 s	7.3 s	9.5 s
Verification	0.6 s	0.8 s	1.0 s	1.2 s	1.7 s	2.2 s	3.0 s	3.9 s	5.6 s	7.3 s
Writing after erasing	1.2 s	1.5 s	1.9 s	2.3 s	3.2 s	4.0 s	5.4 s	6.9 s	9.8 s	12.7 s

Remark The command processing times (reference values) shown in the table are typical values under the following conditions.

Port: TOOL0 (single-line UART)

Speed: 1,000,000 bps

Mode: Full speed mode (flash operation mode: HS (high speed main) mode)

25.6 Self-Programming

The RL78 microcontroller supports a self-programming function that can be used to rewrite the code flash memory via a user program. Because this function allows a user application to rewrite the code flash memory by using the flash self-programming library, it can be used to upgrade the program in the field.

- Cautions**
1. The self-programming function cannot be used when the CPU operates with the subsystem clock.
 2. To prohibit an interrupt during self-programming, in the same way as in the normal operation mode, execute the flash self-programming library in the state where the IE flag is cleared (0) by the DI instruction. To enable an interrupt, clear (0) the interrupt mask flag to accept in the state where the IE flag is set (1) by the EI instruction, and then execute the flash self-programming library.
 3. The high-speed on-chip oscillator should be kept operating during self-programming. If it is kept stopping, the high-speed on-chip oscillator clock should be operated (HIOSTOP = 0). The flash self-programming library should be executed after 30 μ s have elapsed.

Remark For details of the self-programming function, refer to **RL78 Microcontroller Flash Self-Programming Library Type 01 User's Manual (R01US0050)**.

The self-programming function has two flash memory programming modes; wide voltage mode and full speed mode.

Specify the mode that corresponds to the flash operation mode specified in bits CMODE1 and CMODE0 in option byte 000C2H.

Specify the full speed mode when the HS (high speed main) mode is specified. Specify the wide voltage mode when the LS (low speed main) mode or LV (low voltage main) mode is specified.

If the argument `fsl_flash_voltage_u08` is 00H when the `FSL_Init` function of the flash self-programming library provided by Renesas Electronics is executed, full speed mode is specified. If the argument is other than 00H, the wide voltage mode is specified.

Remark Using both the wide voltage mode and full speed mode imposes no restrictions on writing, erasing, or verification.

25.6.1 Self-programming procedure

The following figure illustrates a flow for rewriting the code flash memory by using a flash self-programming library.

Figure 25-8. Flow of Self Programming (Rewriting Flash Memory)

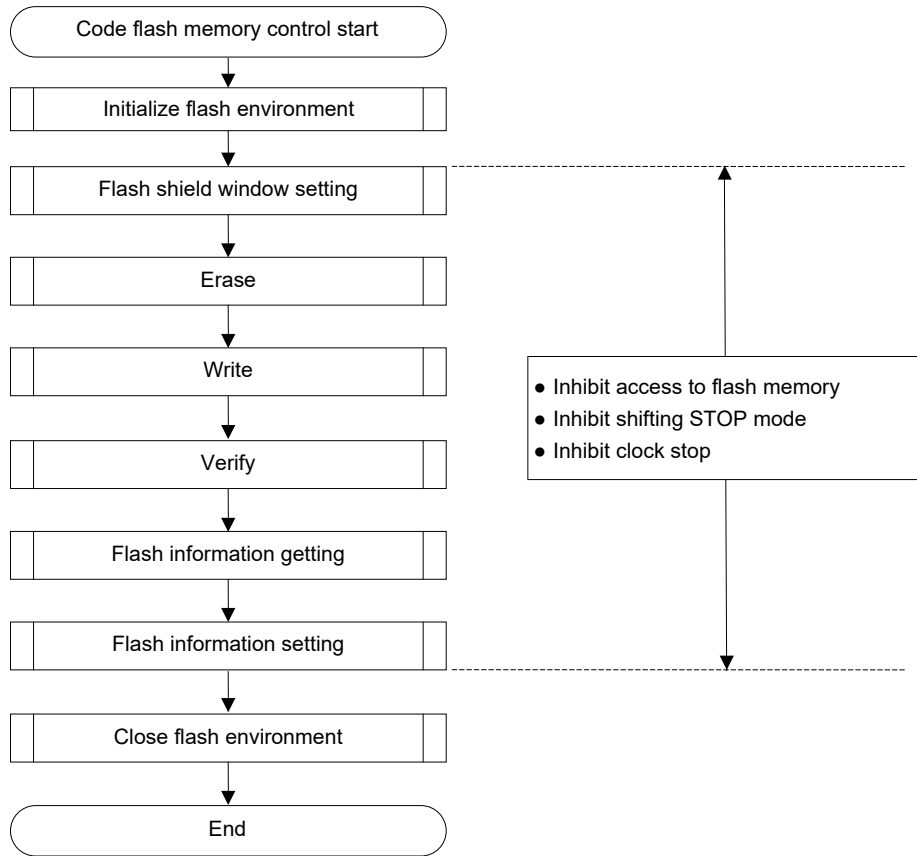

25.6.2 Boot swap function

If rewriting the boot area failed by temporary power failure or other reasons, restarting a program by resetting or overwriting is disabled due to data destruction in the boot area.

The boot swap function is used to avoid this problem.

Before erasing boot cluster 0^{Note}, which is a boot area, by self-programming, write a new boot program to boot cluster 1 in advance. When the program has been correctly written to boot cluster 1, swap this boot cluster 1 and boot cluster 0 by using the set information function of the firmware of the RL78 microcontroller, so that boot cluster 1 is used as a boot area. After that, erase or write the original area, boot cluster 0.

As a result, even if a power failure occurs while the area is being rewritten, the program is executed correctly because it is booted from boot cluster 1 to be swapped when the program is reset and started next.

Note A boot cluster is a 4 KB area and boot clusters 0 and 1 are swapped by the boot swap function.

Figure 25-9. Boot Swap Function

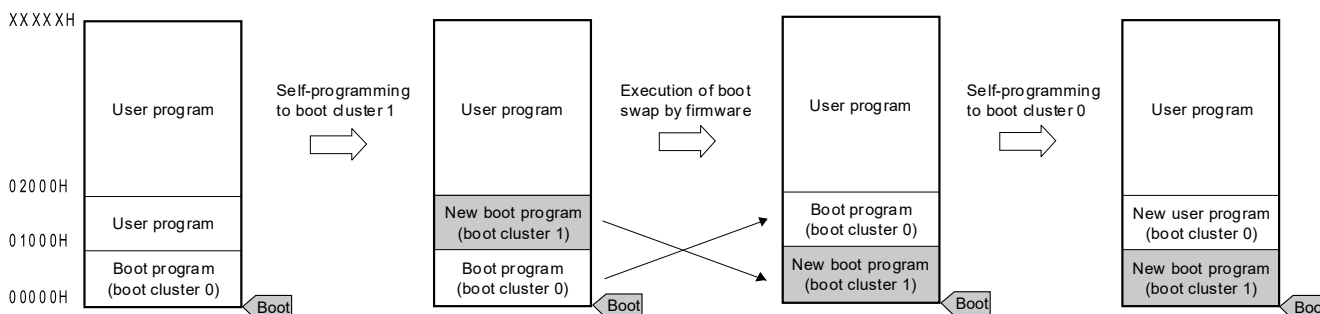

In an example of above figure, it is as follows.

Boot cluster 0: Boot area before boot swap

Boot cluster 1: Boot area after boot swap

Figure 25-10. Example of Executing Boot Swapping

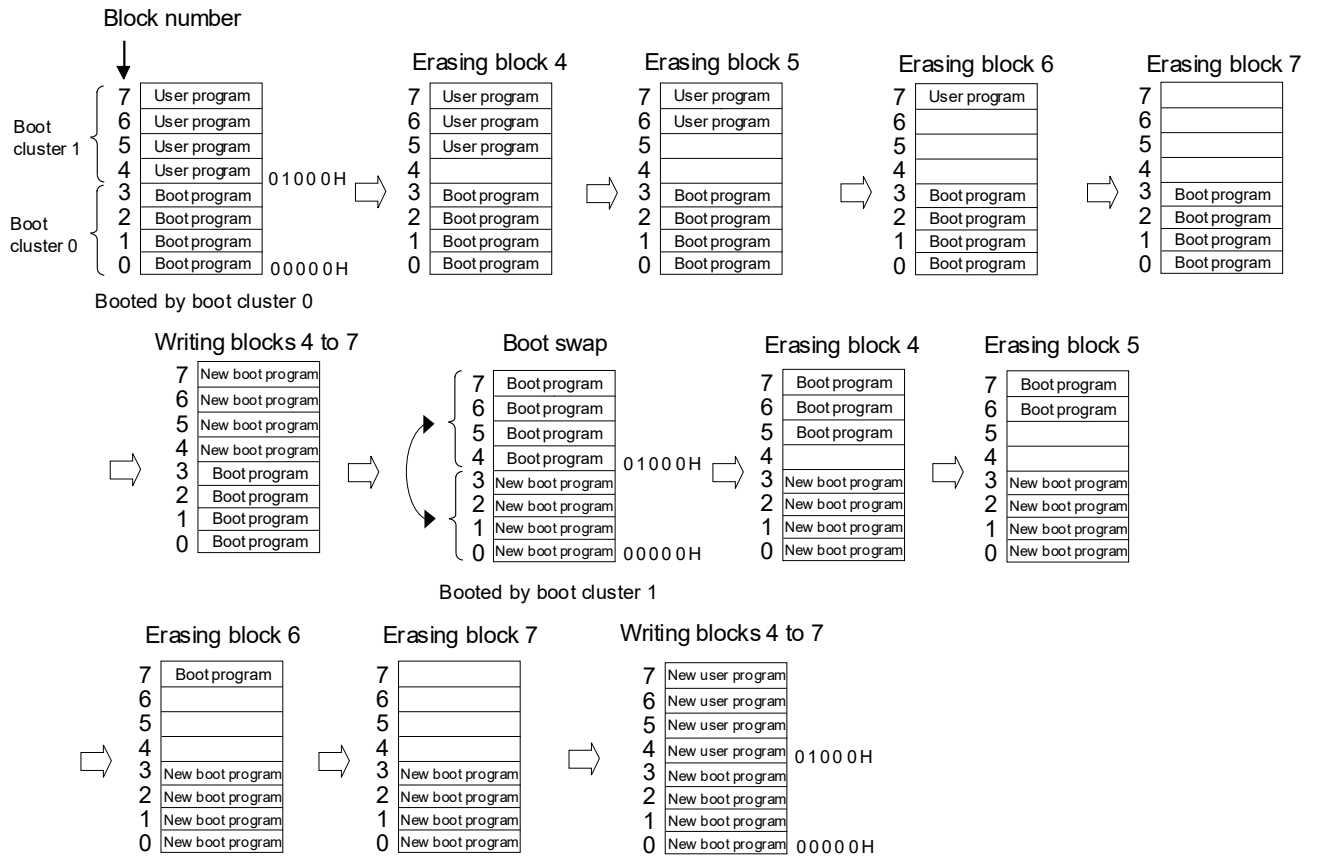

25.6.3 Flash shield window function

The flash shield window function is provided as one of the security functions for self-programming. It disables writing to and erasing areas outside the range specified as a window only during self-programming.

The window range can be set by specifying the start and end blocks. The window range can be set or changed during both serial programming and self-programming.

Writing to and erasing areas outside the window range are disabled during self-programming. During serial programming, however, areas outside the range specified as a window can be written and erased.

Figure 25-11. Flash Shield Window Setting Example
(Target Devices: R5F100LE, Start Block: 04H, End Block: 06H)

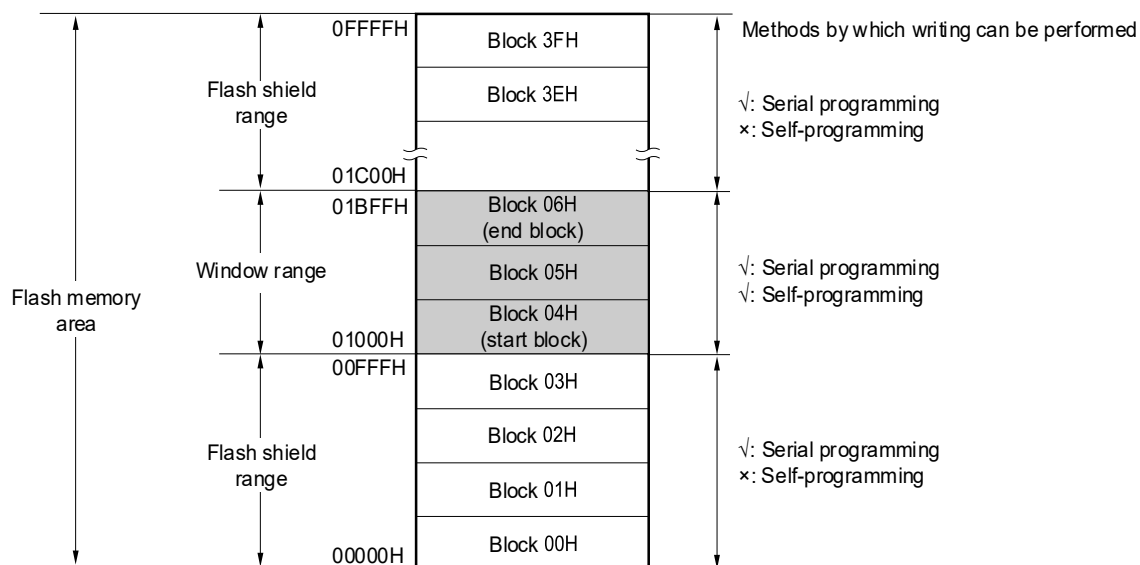

- Cautions**
1. If the rewrite-prohibited area of the boot cluster 0 overlaps with the flash shield window range, prohibition to rewrite the boot cluster 0 takes priority.
 2. The flash shield window can only be used for the code flash memory (and is not supported for the data flash memory).

Table 25-12. Relationship between Flash Shield Window Function Setting/Change Methods and Commands

Programming conditions	Window Range Setting/Change Methods	Execution Commands	
		Block erase	Write
Self-programming	Specify the starting and ending blocks by the flash self-programming library.	Block erasing is enabled only within the window range.	Writing is enabled only within the range of window range.
Serial programming	Specify the starting and ending blocks on GUI of dedicated flash memory programmer, etc.	Block erasing is enabled also outside the window range.	Writing is enabled also outside the window range.

Remark See **25.7 Security Settings** to prohibit writing/erasing during serial programming.

25.7 Security Settings

The RL78 microcontroller supports a security function that prohibits rewriting the user program written to the code flash memory, so that the program cannot be changed by an unauthorized person.

The operations shown below can be performed using the Security Set command.

- **Disabling block erase**
Execution of the block erase command for a specific block in the code flash memory is prohibited during serial programming. However, blocks can be erased by means of self-programming.
- **Disabling write**
Execution of the write command for entire blocks in the code flash memory is prohibited during serial programming. However, blocks can be written by means of self-programming.
After the setting of prohibition of writing is specified, releasing the setting by the Security Release command is enabled by a reset.
- **Disabling rewriting boot cluster 0**
Execution of the block erase command and write command on boot cluster 0 (00000H to 00FFFH) in the code flash memory is prohibited by this setting.

The block erase, write commands and rewriting boot cluster 0 are enabled by the default setting when the flash memory is shipped. Security can be set by serial programming and self-programming. Each security setting can be used in combination.

Table 25-13 shows the relationship between the erase and write commands when the RL78 microcontroller security function is enabled.

Caution The security function of the dedicated flash programmer does not support self-programming.

Remark To prohibit writing and erasing during self-programming, use the flash shield window function (see **25.6.3** for detail).

Table 25-13. Relationship between Enabling Security Function and Command

(1) During serial programming

Valid Security	Executed Command	
	Block Erase	Write
Prohibition of block erase	Blocks cannot be erased.	Can be performed. Note
Prohibition of writing	Blocks can be erased.	Cannot be performed.
Prohibition of rewriting boot cluster 0	Boot cluster 0 cannot be erased.	Boot cluster 0 cannot be written.

Note Confirm that no data has been written to the write area. Because data cannot be erased after block erase is prohibited, do not write data if the data has not been erased.

(2) During self-programming

Valid Security	Executed Command	
	Block Erase	Write
Prohibition of block erase	Blocks can be erased.	Can be performed.
Prohibition of writing		
Prohibition of rewriting boot cluster 0	Boot cluster 0 cannot be erased.	Boot cluster 0 cannot be written.

Remark To prohibit writing and erasing during self-programming, use the flash shield window function (see 25.6.3 for detail).

Table 25-14. Setting Security in Each Programming Mode

(1) During serial programming

Security	Security Setting	How to Disable Security Setting
Prohibition of block erase	Set via GUI of dedicated flash memory programmer, etc.	Cannot be disabled after set.
Prohibition of writing		Set via GUI of dedicated flash memory programmer, etc.
Prohibition of rewriting boot cluster 0		Cannot be disabled after set.

Caution Releasing the setting of prohibition of writing is enabled only when the security is not set as the block erase prohibition and the boot cluster 0 rewrite prohibition with code flash memory area and data flash memory area being blanks.

(2) During self-programming

Security	Security Setting	How to Disable Security Setting
Prohibition of block erase	Set by using flash self-programming library.	Cannot be disabled after set.
Prohibition of writing		Cannot be disabled during self-programming (set via GUI of dedicated flash memory programmer, etc. during serial programming).
Prohibition of rewriting boot cluster 0		Cannot be disabled after set.

25.8 Data Flash

25.8.1 Data flash overview

An overview of the data flash memory is provided below.

- The user program can rewrite the data flash memory by using the data flash library. For details, refer to **RL78 Family Data Flash Library User’s Manual**.
- The data flash memory can also be rewritten to through serial programming using the dedicated flash memory programmer or an external device.
- The data flash can be erased in 1-block (1-Kbyte) units.
- The data flash can be accessed only in 8-bit units.
- The data flash can be directly read by CPU instructions.
- Instructions can be executed from the code flash memory while rewriting the data flash memory (that is, background operation (BGO) is supported).
- Because the data flash memory is an area exclusively used for data, it cannot be used to execute instructions.
- Accessing the data flash memory is not possible while rewriting the code flash memory (during self-programming).
- Manipulating the DFLCTL register is not possible while rewriting the data flash memory.
- Transition to the STOP mode is not possible while rewriting the data flash memory.

- Cautions**
1. The data flash memory is stopped after a reset is canceled. The data flash control register (DFLCTL) must be set up in order to use the data flash memory.
 2. The high-speed on-chip oscillator should be kept operating during data flash rewrite. If it is kept stopping, the high-speed on-chip oscillator clock should be operated (HIOSTOP = 0). The data flash library should be executed after 30 μs have elapsed.

Remark For rewriting the code flash memory via a user program, see **25.6 Self-Programming**.

25.8.2 Register controlling data flash memory

25.8.2.1 Data flash control register (DFLCTL)

This register is used to enable or disable accessing to the data flash.

The DFLCTL register is set by a 1-bit or 8-bit memory manipulation instruction.

Reset input sets this register to 00H.

Figure 25-12. Format of Data Flash Control Register (DFLCTL)

Address: F0090H After reset: 00H R/W

Symbol	7	6	5	4	3	2	1	<0>
DFLCTL	0	0	0	0	0	0	0	DFLEN

DFLEN	Data flash access control
0	Disables data flash access
1	Enables data flash access

Caution Manipulating the DFLCTL register is not possible while rewriting the data flash memory.

25.8.3 Procedure for accessing data flash memory

The data flash memory is stopped after a reset ends. To access the data flash, make initial settings according to the following procedure.

- <1> Set bit 0 (DFLEN) of the data flash control register (DFLCTL) to 1.
- <2> Wait for the setup to finish for software timer, etc.
The time setup takes differs for each flash operation mode for the main clock.
<Setup time for each flash operation mode>
 - HS (High speed main): 5 μ s
 - LS (Low speed main): 720 ns
 - LV (Low voltage main): 10 μ s
- <3> After the wait, the data flash memory can be accessed.

- Cautions**
1. Accessing the data flash memory is not possible during the setup time.
 2. Transition to the STOP mode is not possible during the setup time. To enter the STOP mode during the setup time, clear DFLEN to 0 and then execute the STOP instruction.
 3. The high-speed on-chip oscillator should be kept operating during data flash rewrite. If it is kept stopping, the high-speed on-chip oscillator clock should be operated (HIOSTOP = 0). The
 4. Once the data flash memory is read while the subsystem clock is selected as the CPU/peripheral hardware clock (CLS = 1), follow the procedure listed as steps (1) to (3) below, in that order, to read the data flash area after switching the CPU/peripheral hardware clock from the subsystem clock to the main system clock.
 - (1) Make sure the main system clock is selected as the CPU/peripheral hardware clock (CLS = 0).
 - (2) Read data from any location in the data flash area. The value read at this point is undefined.
 - (3) Wait for the time listed below according to the operating mode, then read data from the desired parts of the data flash area.

HS (high-speed main) mode:	5 μ s
LS (low-speed main) mode:	1 μ s
LV (low-voltage main) mode:	10 μ s

After initialized, the data flash memory can be read by using a CPU instruction or can be read/written by using a data flash library.

If the DMA controller operates when the data flash memory is accessed, however, follow one of these procedures:

(A) Suspending/forcibly terminating DMA transfer

Before reading the data flash memory, suspend DMA transfer of all the channels used.

After setting the DWAITn bit to 1, however, wait at least for the duration of three clocks (f_{CLK}) before reading the data flash memory. After reading the data flash memory, lift the suspension of transfer by clearing the DWAITn bit to 0.

Or, forcibly terminate DMA transfer in accordance with the procedure in **15.5.5 Forced termination by software** before reading the data flash memory. Resume DMA transfer after the data flash memory has been read.

(B) Access the data flash memory

Access the data flash memory by using the newest data flash library.

(C) Insertion of NOP

Insert an NOP instruction immediately before the instruction that reads the data flash memory.

<Example>

```
MOVW      HL,!addr16      ; Reads RAM.
NOP                               ; Insert NOP instruction before reading data flash memory.
MOV      A,[DE]           ; Read data flash memory.
```

If a high-level language such as C is used, however, the compiler may generate two instructions for one code. In this case, the NOP instruction is not inserted immediately before the data flash memory read instruction. Therefore, read the data flash memory by (A) or (B) above.

- Remarks**
1. n: DMA channel number (n = 0, 1)
 2. f_{CLK} : CPU/peripheral hardware clock frequency

CHAPTER 26 ON-CHIP DEBUG FUNCTION

26.1 Connecting E1, E2, E2 Lite, E20 On-chip Debugging Emulator

The RL78 microcontroller uses the V_{DD}, $\overline{\text{RESET}}$, TOOL0, and V_{SS} pins to communicate with the host machine via an E1, E2, E2 Lite, E20 on-chip debugging emulator. Serial communication is performed by using a single-line UART that uses the TOOL0 pin.

Caution The RL78 microcontroller has an on-chip debug function, which is provided for development and evaluation. Do not use the on-chip debug function in products designated for mass production, because the guaranteed number of rewritable times of the flash memory may be exceeded when this function is used, and product reliability therefore cannot be guaranteed. Renesas Electronics is not liable for problems occurring when the on-chip debug function is used.

Figure 26-1. Connection Example of E1, E2, E2 Lite, E20 On-chip Debugging Emulator

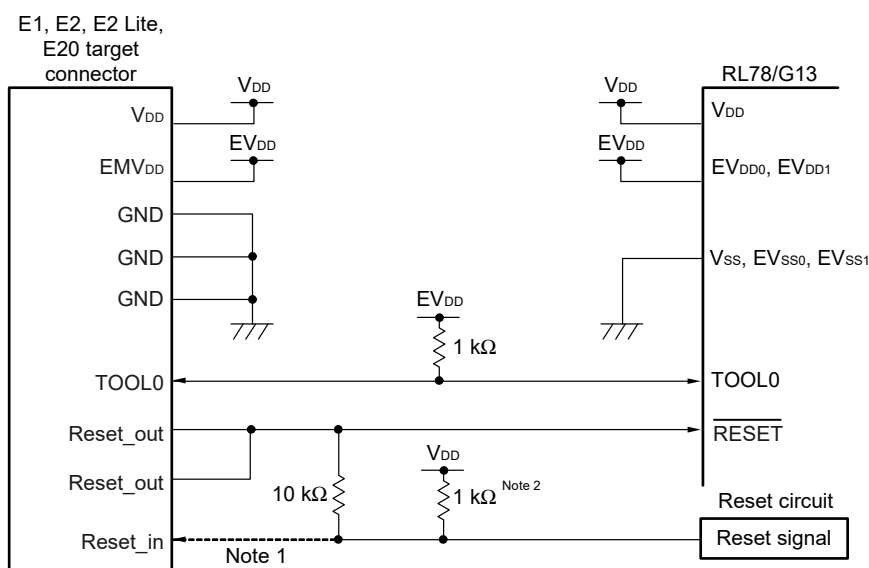

- Notes 1.** Connecting the dotted line is not necessary during serial programming.
- 2.** If the reset circuit on the target system does not have a buffer and generates a reset signal only with resistors and capacitors, this pull-up resistor is not necessary.

Caution This circuit diagram is assumed that the reset signal outputs from an N-ch open-drain buffer (output resistor: 100 Ω or less)

Remark With products not provided with an EV_{DD0}, EV_{DD1}, EV_{SS0}, or EV_{SS1} pin, replace EV_{DD0} and EV_{DD1} with V_{DD}, or replace EV_{SS0} and EV_{SS1} with V_{SS}.

26.2 On-Chip Debug Security ID

The RL78 microcontroller has an on-chip debug operation control bit in the flash memory at 000C3H (see **CHAPTER 24 OPTION BYTE**) and an on-chip debug security ID setting area at 000C4H to 000CDH, to prevent third parties from reading memory content.

When the boot swap function is used, also set a value that is the same as that of 010C3H and 010C4H to 010CDH in advance, because 000C3H, 000C4H to 000CDH and 010C3H, and 010C4H to 010CDH are switched.

Table 26-1. On-Chip Debug Security ID

Address	On-Chip Debug Security ID
000C4H to 000CDH	Any ID code of 10 bytes ^{Note}
010C4H to 010CDH	

Note. The setting FFFFFFFFFFFFFFFFFFH for the ID code is not possible.

26.3 Securing of User Resources

To perform communication between the RL78 microcontroller and E1, E2, E2 Lite, E20 on-chip debugging emulator, as well as each debug function, the securing of memory space must be done beforehand.

If Renesas Electronics assembler or compiler is used, the items can be set by using link options.

(1) Securement of memory space

The shaded portions in Figure 26-2 are the areas reserved for placing the debug monitor program, so user programs or data cannot be allocated in these spaces. When using the on-chip debug function, these spaces must be secured so as not to be used by the user program. Moreover, this area must not be rewritten by the user program.

Figure 26-2. Memory Spaces Where Debug Monitor Programs Are Allocated

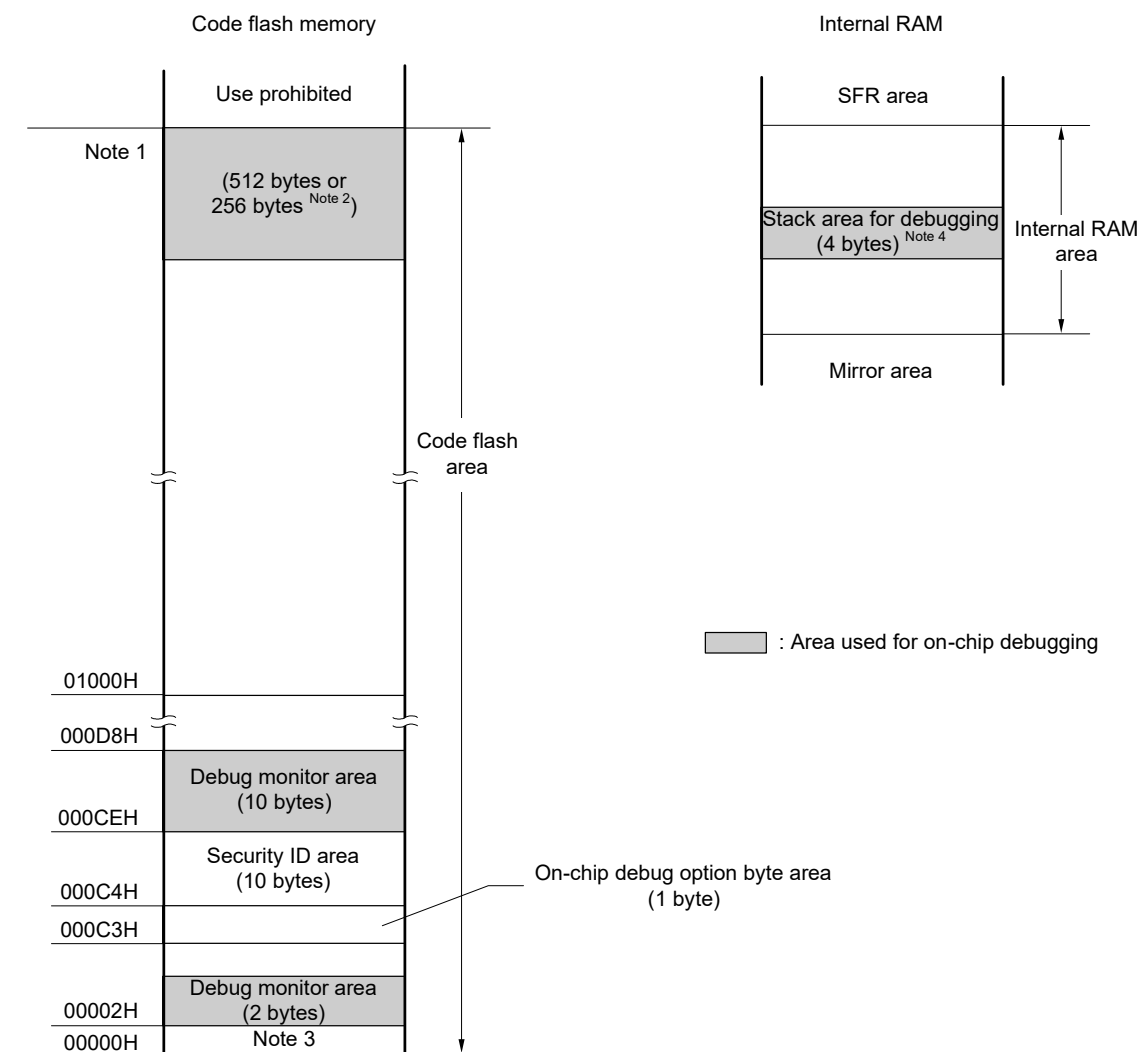

Notes 1. Address differs depending on products as follows.

Products (code flash memory capacity)	Address of Note 1
R5F100xA, R5F101xA (x = 6 to 8, A to C, E to G)	03FFFFH
R5F100xC, R5F101xC (x = 6 to 8, A to C, E to G, J, L)	07FFFFH
R5F100xD, R5F101xD (x = 6 to 8, A to C, E to G, J, L)	0BFFFFH
R5F100xE, R5F101xE (x = 6 to 8, A to C, E to G, J, L)	0FFFFFFH
R5F100xF, R5F101xF (x = A to C, E to G, J, L, M, P)	17FFFFH
R5F100xG, R5F101xG (x = A to C, E to G, J, L, M, P)	1FFFFFFH
R5F100xH, R5F101xH (x = E to G, J, L, M, P, S)	2FFFFFFH
R5F100xJ, R5F101xJ (x = F, G, J, L, M, P, S)	3FFFFFFH
R5F100xK, R5F101xK (x = F, G, J, L, M, P, S)	5FFFFFFH
R5F100xL, R5F101xL (x = F, G, J, L, M, P, S)	7FFFFFFH

- When real-time RAM monitor (RRM) function and dynamic memory modification (DMM) function are not used, it is 256 bytes.
- In debugging, reset vector is rewritten to address allocated to a monitor program.
- Since this area is allocated immediately before the stack area, the address of this area varies depending on the stack increase and decrease. That is, 4 extra bytes are consumed for the stack area used. When using self-programming, 12 extra bytes are consumed for the stack area used.

CHAPTER 27 BCD CORRECTION CIRCUIT

27.1 BCD Correction Circuit Function

The result of addition/subtraction of the BCD (binary-coded decimal) code and BCD code can be obtained as BCD code with this circuit.

The decimal correction operation result is obtained by performing addition/subtraction having the A register as the operand and then adding/ subtracting the BCD correction result register (BCDADJ).

27.2 Registers Used by BCD Correction Circuit

The BCD correction circuit uses the following registers.

- BCD correction result register (BCDADJ)

27.2.1 BCD correction result register (BCDADJ)

The BCDADJ register stores correction values for obtaining the add/subtract result as BCD code through add/subtract instructions using the A register as the operand.

The value read from the BCDADJ register varies depending on the value of the A register when it is read and those of the CY and AC flags.

The BCDADJ register is read by an 8-bit memory manipulation instruction.

Reset input sets this register to undefined.

Figure 27-1. Format of BCD Correction Result Register (BCDADJ)

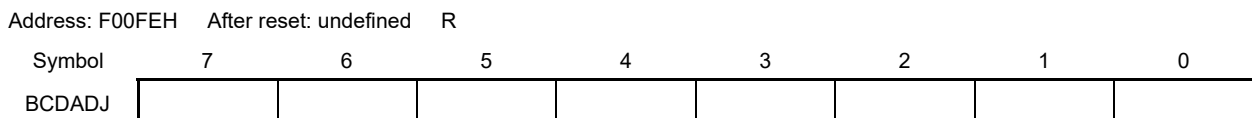

27.3 BCD Correction Circuit Operation

The basic operation of the BCD correction circuit is as follows.

(1) Addition: Calculating the result of adding a BCD code value and another BCD code value by using a BCD code value

- <1> The BCD code value to which addition is performed is stored in the A register.
- <2> By adding the value of the A register and the second operand (value of one more BCD code to be added) as are in binary, the binary operation result is stored in the A register and the correction value is stored in the BCD correction result register (BCDADJ).
- <3> Decimal correction is performed by adding in binary the value of the A register (addition result in binary) and the BCDADJ register (correction value), and the correction result is stored in the A register and CY flag.

Caution The value read from the BCDADJ register varies depending on the value of the A register when it is read and those of the CY and AC flags. Therefore, execute the instruction <3> after the instruction <2> instead of executing any other instructions. To perform BCD correction in the interrupt enabled state, saving and restoring the A register is required within the interrupt function. PSW (CY flag and AC flag) is restored by the RETI instruction.

An example is shown below.

Examples 1: 99 + 89 = 188

Instruction	A Register	CY Flag	AC Flag	BCDADJ Register
MOV A, #99H ; <1>	99H	–	–	–
ADD A, #89H ; <2>	22H	1	1	66H
ADD A, !BCDADJ ; <3>	88H	1	0	–

Examples 2: 85 + 15 = 100

Instruction	A Register	CY Flag	AC Flag	BCDADJ Register
MOV A, #85H ; <1>	85H	–	–	–
ADD A, #15H ; <2>	9AH	0	0	66H
ADD A, !BCDADJ ; <3>	00H	1	1	–

Examples 3: 80 + 80 = 160

Instruction	A Register	CY Flag	AC Flag	BCDADJ Register
MOV A, #80H ; <1>	80H	–	–	–
ADD A, #80H ; <2>	00H	1	0	60H
ADD A, !BCDADJ ; <3>	60H	1	0	–

(2) Subtraction: Calculating the result of subtracting a BCD code value from another BCD code value by using a BCD code value

- <1> The BCD code value from which subtraction is performed is stored in the A register.
- <2> By subtracting the value of the second operand (value of BCD code to be subtracted) from the A register as is in binary, the calculation result in binary is stored in the A register, and the correction value is stored in the BCD correction result register (BCDADJ).
- <3> Decimal correction is performed by subtracting the value of the BCDADJ register (correction value) from the A register (subtraction result in binary) in binary, and the correction result is stored in the A register and CY flag.

Caution The value read from the BCDADJ register varies depending on the value of the A register when it is read and those of the CY and AC flags. Therefore, execute the instruction <3> after the instruction <2> instead of executing any other instructions. To perform BCD correction in the interrupt enabled state, saving and restoring the A register is required within the interrupt function. PSW (CY flag and AC flag) is restored by the RETI instruction.

An example is shown below.

Example: $91 - 52 = 39$

Instruction	A Register	CY Flag	AC Flag	BCDADJ Register
MOV A, #91H ; <1>	91H	–	–	–
SUB A, #52H ; <2>	3FH	0	1	06H
SUB A, !BCDADJ ; <3>	39H	0	0	–

CHAPTER 28 INSTRUCTION SET

This chapter lists the instructions in the RL78 microcontroller instruction set. For details of each operation and operation code, refer to the separate document **RL78 Family User's Manual: Software (R01US0015E)**.

28.1 Conventions Used in Operation List

28.1.1 Operand identifiers and specification methods

Operands are described in the “Operand” column of each instruction in accordance with the description method of the instruction operand identifier (refer to the assembler specifications for details). When there are two or more description methods, select one of them. Alphabetic letters in capitals and the symbols, #, !, !!, \$, \$!, [], and ES: are keywords and are described as they are. Each symbol has the following meaning.

- #: Immediate data specification
- !: 16-bit absolute address specification
- !!: 20-bit absolute address specification
- \$: 8-bit relative address specification
- \$!: 16-bit relative address specification
- []: Indirect address specification
- ES:: Extension address specification

In the case of immediate data, describe an appropriate numeric value or a label. When using a label, be sure to describe the #, !, !!, \$, \$!, [], and ES: symbols.

For operand register identifiers, r and rp, either function names (X, A, C, etc.) or absolute names (names in parentheses in the table below, R0, R1, R2, etc.) can be used for description.

Table 28-1. Operand Identifiers and Specification Methods

Identifier	Description Method
r	X (R0), A (R1), C (R2), B (R3), E (R4), D (R5), L (R6), H (R7)
rp	AX (RP0), BC (RP1), DE (RP2), HL (RP3)
sfr	Special-function register symbol (SFR symbol) FFF00H to FFFFFH
sfrp	Special-function register symbols (16-bit manipulatable SFR symbol. Even addresses only ^{Note}) FFF00H to FFFFFH
saddr	FFE20H to FFF1FH Immediate data or labels
saddrp	FFE20H to FF1FH Immediate data or labels (even addresses only ^{Note})
addr20	00000H to FFFFFH Immediate data or labels
addr16	0000H to FFFFH Immediate data or labels (only even addresses for 16-bit data transfer instructions ^{Note})
addr5	0080H to 00BFH Immediate data or labels (even addresses only ^{Note})
word	16-bit immediate data or label
byte	8-bit immediate data or label
bit	3-bit immediate data or label
RBn	RB0 to RB3

Note Bit 0 = 0 when an odd address is specified.

Remark The special function registers can be described to operand sfr as symbols. See **Table 3-5 SFR List** for the symbols of the special function registers. The extended special function registers can be described to operand laddr16 as symbols. See **Table 3-6 Extended SFR (2nd SFR) List** for the symbols of the extended special function registers.

28.1.2 Description of operation column

The operation when the instruction is executed is shown in the “Operation” column using the following symbols.

Table 28-2. Symbols in “Operation” Column

Symbol	Function
A	A register; 8-bit accumulator
X	X register
B	B register
C	C register
D	D register
E	E register
H	H register
L	L register
ES	ES register
CS	CS register
AX	AX register pair; 16-bit accumulator
BC	BC register pair
DE	DE register pair
HL	HL register pair
PC	Program counter
SP	Stack pointer
PSW	Program status word
CY	Carry flag
AC	Auxiliary carry flag
Z	Zero flag
RBS	Register bank select flag
IE	Interrupt request enable flag
()	Memory contents indicated by address or register contents in parentheses
X _H , X _L	16-bit registers: X _H = higher 8 bits, X _L = lower 8 bits
X _S , X _H , X _L	20-bit registers: X _S = (bits 19 to 16), X _H = (bits 15 to 8), X _L = (bits 7 to 0)
∧	Logical product (AND)
∨	Logical sum (OR)
⊕	Exclusive logical sum (exclusive OR)
–	Inverted data
addr5	16-bit immediate data (even addresses only in 0080H to 00BFH)
addr16	16-bit immediate data
addr20	20-bit immediate data
jdisp8	Signed 8-bit data (displacement value)
jdisp16	Signed 16-bit data (displacement value)

28.1.3 Description of flag operation column

The change of the flag value when the instruction is executed is shown in the “Flag” column using the following symbols.

Table 28-3. Symbols in “Flag” Column

Symbol	Change of Flag Value
(Blank)	Unchanged
0	Cleared to 0
1	Set to 1
x	Set/cleared according to the result
R	Previously saved value is restored

28.1.4 PREFIX instruction

Instructions with “ES:” have a PREFIX operation code as a prefix to extend the accessible data area to the 1 MB space (00000H to FFFFFH), by adding the ES register value to the 64 KB space from F0000H to FFFFFH. When a PREFIX operation code is attached as a prefix to the target instruction, only one instruction immediately after the PREFIX operation code is executed as the addresses with the ES register value added.

A interrupt and DMA transfer are not acknowledged between a PREFIX instruction code and the instruction immediately after.

Table 28-4. Use Example of PREFIX Operation Code

Instruction	Opcode				
	1	2	3	4	5
MOV !addr16, #byte	CFH	!addr16		#byte	–
MOV ES:!addr16, #byte	11H	CFH	!addr16		#byte
MOV A, [HL]	8BH	–	–	–	–
MOV A, ES:[HL]	11H	8BH	–	–	–

Caution Set the ES register value with MOV ES, A, etc., before executing the PREFIX instruction.

28.2 Operation List

Table 28-5. Operation List (1/17)

Instruction Group	Mnemonic	Operands	Bytes	Clocks		Operation	Flag		
				Note 1	Note 2		Z	AC	CY
8-bit data transfer	MOV	r, #byte	2	1	–	$r \leftarrow \text{byte}$			
		PSW, #byte	3	3	–	$\text{PSW} \leftarrow \text{byte}$	x	x	x
		CS, #byte	3	1	–	$\text{CS} \leftarrow \text{byte}$			
		ES, #byte	2	1	–	$\text{ES} \leftarrow \text{byte}$			
		!addr16, #byte	4	1	–	$(\text{addr16}) \leftarrow \text{byte}$			
		ES:!addr16, #byte	5	2	–	$(\text{ES}, \text{addr16}) \leftarrow \text{byte}$			
		saddr, #byte	3	1	–	$(\text{saddr}) \leftarrow \text{byte}$			
		sfr, #byte	3	1	–	$\text{sfr} \leftarrow \text{byte}$			
		[DE+byte], #byte	3	1	–	$(\text{DE}+\text{byte}) \leftarrow \text{byte}$			
		ES:[DE+byte],#byte	4	2	–	$((\text{ES}, \text{DE})+\text{byte}) \leftarrow \text{byte}$			
		[HL+byte], #byte	3	1	–	$(\text{HL}+\text{byte}) \leftarrow \text{byte}$			
		ES:[HL+byte],#byte	4	2	–	$((\text{ES}, \text{HL})+\text{byte}) \leftarrow \text{byte}$			
		[SP+byte], #byte	3	1	–	$(\text{SP}+\text{byte}) \leftarrow \text{byte}$			
		word[B], #byte	4	1	–	$(\text{B}+\text{word}) \leftarrow \text{byte}$			
		ES:word[B], #byte	5	2	–	$((\text{ES}, \text{B})+\text{word}) \leftarrow \text{byte}$			
		word[C], #byte	4	1	–	$(\text{C}+\text{word}) \leftarrow \text{byte}$			
		ES:word[C], #byte	5	2	–	$((\text{ES}, \text{C})+\text{word}) \leftarrow \text{byte}$			
		word[BC], #byte	4	1	–	$(\text{BC}+\text{word}) \leftarrow \text{byte}$			
		ES:word[BC], #byte	5	2	–	$((\text{ES}, \text{BC})+\text{word}) \leftarrow \text{byte}$			
		A, r ^{Note 3}	1	1	–	$\text{A} \leftarrow r$			
		r, A ^{Note 3}	1	1	–	$r \leftarrow \text{A}$			
		A, PSW	2	1	–	$\text{A} \leftarrow \text{PSW}$			
		PSW, A	2	3	–	$\text{PSW} \leftarrow \text{A}$	x	x	x
		A, CS	2	1	–	$\text{A} \leftarrow \text{CS}$			
		CS, A	2	1	–	$\text{CS} \leftarrow \text{A}$			
		A, ES	2	1	–	$\text{A} \leftarrow \text{ES}$			
		ES, A	2	1	–	$\text{ES} \leftarrow \text{A}$			
		A, !addr16	3	1	4	$\text{A} \leftarrow (\text{addr16})$			
		A, ES:!addr16	4	2	5	$\text{A} \leftarrow (\text{ES}, \text{addr16})$			
		!addr16, A	3	1	–	$(\text{addr16}) \leftarrow \text{A}$			
ES:!addr16, A	4	2	–	$(\text{ES}, \text{addr16}) \leftarrow \text{A}$					
A, saddr	2	1	–	$\text{A} \leftarrow (\text{saddr})$					
saddr, A	2	1	–	$(\text{saddr}) \leftarrow \text{A}$					

- Notes 1.** Number of CPU clocks (f_{CLK}) when the internal RAM area, SFR area, or extended SFR area is accessed, or when no data is accessed.
- 2.** Number of CPU clocks (f_{CLK}) when the code flash memory is accessed, or when the data flash memory is accessed by an 8-bit instruction.
- 3.** Except $r = \text{A}$

Remark Number of clock is when program exists in the internal ROM (flash memory) area. If fetching the instruction from the internal RAM area, the number becomes double number plus 3 clocks at a maximum.

Table 28-5. Operation List (2/17)

Instruction Group	Mnemonic	Operands	Bytes	Clocks		Operation	Flag		
				Note 1	Note 2		Z	AC	CY
8-bit data transfer	MOV	A, sfr	2	1	–	$A \leftarrow \text{sfr}$			
		sfr, A	2	1	–	$\text{sfr} \leftarrow A$			
		A, [DE]	1	1	4	$A \leftarrow (\text{DE})$			
		[DE], A	1	1	–	$(\text{DE}) \leftarrow A$			
		A, ES:[DE]	2	2	5	$A \leftarrow (\text{ES}, \text{DE})$			
		ES:[DE], A	2	2	–	$(\text{ES}, \text{DE}) \leftarrow A$			
		A, [HL]	1	1	4	$A \leftarrow (\text{HL})$			
		[HL], A	1	1	–	$(\text{HL}) \leftarrow A$			
		A, ES:[HL]	2	2	5	$A \leftarrow (\text{ES}, \text{HL})$			
		ES:[HL], A	2	2	–	$(\text{ES}, \text{HL}) \leftarrow A$			
		A, [DE+byte]	2	1	4	$A \leftarrow (\text{DE} + \text{byte})$			
		[DE+byte], A	2	1	–	$(\text{DE} + \text{byte}) \leftarrow A$			
		A, ES:[DE+byte]	3	2	5	$A \leftarrow ((\text{ES}, \text{DE}) + \text{byte})$			
		ES:[DE+byte], A	3	2	–	$((\text{ES}, \text{DE}) + \text{byte}) \leftarrow A$			
		A, [HL+byte]	2	1	4	$A \leftarrow (\text{HL} + \text{byte})$			
		[HL+byte], A	2	1	–	$(\text{HL} + \text{byte}) \leftarrow A$			
		A, ES:[HL+byte]	3	2	5	$A \leftarrow ((\text{ES}, \text{HL}) + \text{byte})$			
		ES:[HL+byte], A	3	2	–	$((\text{ES}, \text{HL}) + \text{byte}) \leftarrow A$			
		A, [SP+byte]	2	1	–	$A \leftarrow (\text{SP} + \text{byte})$			
		[SP+byte], A	2	1	–	$(\text{SP} + \text{byte}) \leftarrow A$			
		A, word[B]	3	1	4	$A \leftarrow (\text{B} + \text{word})$			
		word[B], A	3	1	–	$(\text{B} + \text{word}) \leftarrow A$			
		A, ES:word[B]	4	2	5	$A \leftarrow ((\text{ES}, \text{B}) + \text{word})$			
		ES:word[B], A	4	2	–	$((\text{ES}, \text{B}) + \text{word}) \leftarrow A$			
		A, word[C]	3	1	4	$A \leftarrow (\text{C} + \text{word})$			
		word[C], A	3	1	–	$(\text{C} + \text{word}) \leftarrow A$			
		A, ES:word[C]	4	2	5	$A \leftarrow ((\text{ES}, \text{C}) + \text{word})$			
		ES:word[C], A	4	2	–	$((\text{ES}, \text{C}) + \text{word}) \leftarrow A$			
		A, word[BC]	3	1	4	$A \leftarrow (\text{BC} + \text{word})$			
		word[BC], A	3	1	–	$(\text{BC} + \text{word}) \leftarrow A$			
A, ES:word[BC]	4	2	5	$A \leftarrow ((\text{ES}, \text{BC}) + \text{word})$					
ES:word[BC], A	4	2	–	$((\text{ES}, \text{BC}) + \text{word}) \leftarrow A$					

Notes 1. Number of CPU clocks (f_{CLK}) when the internal RAM area, SFR area, or extended SFR area is accessed, or when no data is accessed.

2. Number of CPU clocks (f_{CLK}) when the code flash memory is accessed, or when the data flash memory is accessed by an 8-bit instruction.

Remark Number of clock is when program exists in the internal ROM (flash memory) area. If fetching the instruction from the internal RAM area, the number becomes double number plus 3 clocks at a maximum.

Table 28-5. Operation List (3/17)

Instruction Group	Mnemonic	Operands	Bytes	Clocks		Operation	Flag		
				Note 1	Note 2		Z	AC	CY
8-bit data transfer	MOV	A, [HL+B]	2	1	4	$A \leftarrow (HL + B)$			
		[HL+B], A	2	1	–	$(HL + B) \leftarrow A$			
		A, ES:[HL+B]	3	2	5	$A \leftarrow ((ES, HL) + B)$			
		ES:[HL+B], A	3	2	–	$((ES, HL) + B) \leftarrow A$			
		A, [HL+C]	2	1	4	$A \leftarrow (HL + C)$			
		[HL+C], A	2	1	–	$(HL + C) \leftarrow A$			
		A, ES:[HL+C]	3	2	5	$A \leftarrow ((ES, HL) + C)$			
		ES:[HL+C], A	3	2	–	$((ES, HL) + C) \leftarrow A$			
		X, laddr16	3	1	4	$X \leftarrow (\text{addr16})$			
		X, ES:laddr16	4	2	5	$X \leftarrow (ES, \text{addr16})$			
		X, saddr	2	1	–	$X \leftarrow (\text{saddr})$			
		B, laddr16	3	1	4	$B \leftarrow (\text{addr16})$			
		B, ES:laddr16	4	2	5	$B \leftarrow (ES, \text{addr16})$			
		B, saddr	2	1	–	$B \leftarrow (\text{saddr})$			
		C, laddr16	3	1	4	$C \leftarrow (\text{addr16})$			
		C, ES:laddr16	4	2	5	$C \leftarrow (ES, \text{addr16})$			
		C, saddr	2	1	–	$C \leftarrow (\text{saddr})$			
	ES, saddr	3	1	–	$ES \leftarrow (\text{saddr})$				
	XCH	A, r ^{Note 3}	1 (r = X) 2 (other than r = X)	1	–	$A \leftrightarrow r$			
		A, laddr16	4	2	–	$A \leftrightarrow (\text{addr16})$			
		A, ES:laddr16	5	3	–	$A \leftrightarrow (ES, \text{addr16})$			
		A, saddr	3	2	–	$A \leftrightarrow (\text{saddr})$			
		A, sfr	3	2	–	$A \leftrightarrow \text{sfr}$			
		A, [DE]	2	2	–	$A \leftrightarrow (DE)$			
		A, ES:[DE]	3	3	–	$A \leftrightarrow (ES, DE)$			
		A, [HL]	2	2	–	$A \leftrightarrow (HL)$			
		A, ES:[HL]	3	3	–	$A \leftrightarrow (ES, HL)$			
		A, [DE+byte]	3	2	–	$A \leftrightarrow (DE + \text{byte})$			
A, ES:[DE+byte]		4	3	–	$A \leftrightarrow ((ES, DE) + \text{byte})$				
A, [HL+byte]	3	2	–	$A \leftrightarrow (HL + \text{byte})$					
A, ES:[HL+byte]	4	3	–	$A \leftrightarrow ((ES, HL) + \text{byte})$					

- Notes 1.** Number of CPU clocks (f_{CLK}) when the internal RAM area, SFR area, or extended SFR area is accessed, or when no data is accessed.
- 2.** Number of CPU clocks (f_{CLK}) when the code flash memory is accessed, or when the data flash memory is accessed by an 8-bit instruction.
- 3.** Except $r = A$

Remark Number of clock is when program exists in the internal ROM (flash memory) area. If fetching the instruction from the internal RAM area, the number becomes double number plus 3 clocks at a maximum.

Table 28-5. Operation List (4/17)

Instruction Group	Mnemonic	Operands	Bytes	Clocks		Operation	Flag			
				Note 1	Note 2		Z	AC	CY	
8-bit data transfer	XCH	A, [HL+B]	2	2	–	$A \leftrightarrow (HL+B)$				
		A, ES:[HL+B]	3	3	–	$A \leftrightarrow ((ES, HL)+B)$				
		A, [HL+C]	2	2	–	$A \leftrightarrow (HL+C)$				
		A, ES:[HL+C]	3	3	–	$A \leftrightarrow ((ES, HL)+C)$				
	ONEB	A	1	1	–	$A \leftarrow 01H$				
		X	1	1	–	$X \leftarrow 01H$				
		B	1	1	–	$B \leftarrow 01H$				
		C	1	1	–	$C \leftarrow 01H$				
		!addr16	3	1	–	$(addr16) \leftarrow 01H$				
		ES:!addr16	4	2	–	$(ES, addr16) \leftarrow 01H$				
		saddr	2	1	–	$(saddr) \leftarrow 01H$				
	CLRB	A	1	1	–	$A \leftarrow 00H$				
		X	1	1	–	$X \leftarrow 00H$				
		B	1	1	–	$B \leftarrow 00H$				
		C	1	1	–	$C \leftarrow 00H$				
		!addr16	3	1	–	$(addr16) \leftarrow 00H$				
		ES:!addr16	4	2	–	$(ES, addr16) \leftarrow 00H$				
		saddr	2	1	–	$(saddr) \leftarrow 00H$				
	MOVS	[HL+byte], X	3	1	–	$(HL+byte) \leftarrow X$	x		x	
		ES:[HL+byte], X	4	2	–	$(ES, HL+byte) \leftarrow X$	x		x	
	16-bit data transfer	MOVW	rp, #word	3	1	–	$rp \leftarrow word$			
			saddrp, #word	4	1	–	$(saddrp) \leftarrow word$			
			sfrp, #word	4	1	–	$sfrp \leftarrow word$			
AX, rp ^{Note 3}			1	1	–	$AX \leftarrow rp$				
rp, AX ^{Note 3}			1	1	–	$rp \leftarrow AX$				
AX, !addr16			3	1	4	$AX \leftarrow (addr16)$				
!addr16, AX			3	1	–	$(addr16) \leftarrow AX$				
AX, ES:!addr16			4	2	5	$AX \leftarrow (ES, addr16)$				
ES:!addr16, AX			4	2	–	$(ES, addr16) \leftarrow AX$				
AX, saddrp			2	1	–	$AX \leftarrow (saddrp)$				
saddrp, AX			2	1	–	$(saddrp) \leftarrow AX$				
AX, sfrp			2	1	–	$AX \leftarrow sfrp$				
sfrp, AX			2	1	–	$sfrp \leftarrow AX$				

- Notes**
1. Number of CPU clocks (f_{CLK}) when the internal RAM area, SFR area, or extended SFR area is accessed, or when no data is accessed.
 2. Number of CPU clocks (f_{CLK}) when the code flash memory is accessed, or when the data flash memory is accessed by an 8-bit instruction.
 3. Except $rp = AX$

Remark Number of clock is when program exists in the internal ROM (flash memory) area. If fetching the instruction from the internal RAM area, the number becomes double number plus 3 clocks at a maximum.

Table 28-5. Operation List (5/17)

Instruction Group	Mnemonic	Operands	Bytes	Clocks		Operation	Flag		
				Note 1	Note 2		Z	AC	CY
16-bit data transfer	MOVW	AX, [DE]	1	1	4	$AX \leftarrow (DE)$			
		[DE], AX	1	1	–	$(DE) \leftarrow AX$			
		AX, ES:[DE]	2	2	5	$AX \leftarrow (ES, DE)$			
		ES:[DE], AX	2	2	–	$(ES, DE) \leftarrow AX$			
		AX, [HL]	1	1	4	$AX \leftarrow (HL)$			
		[HL], AX	1	1	–	$(HL) \leftarrow AX$			
		AX, ES:[HL]	2	2	5	$AX \leftarrow (ES, HL)$			
		ES:[HL], AX	2	2	–	$(ES, HL) \leftarrow AX$			
		AX, [DE+byte]	2	1	4	$AX \leftarrow (DE+byte)$			
		[DE+byte], AX	2	1	–	$(DE+byte) \leftarrow AX$			
		AX, ES:[DE+byte]	3	2	5	$AX \leftarrow ((ES, DE) + byte)$			
		ES:[DE+byte], AX	3	2	–	$((ES, DE) + byte) \leftarrow AX$			
		AX, [HL+byte]	2	1	4	$AX \leftarrow (HL + byte)$			
		[HL+byte], AX	2	1	–	$(HL + byte) \leftarrow AX$			
		AX, ES:[HL+byte]	3	2	5	$AX \leftarrow ((ES, HL) + byte)$			
		ES:[HL+byte], AX	3	2	–	$((ES, HL) + byte) \leftarrow AX$			
		AX, [SP+byte]	2	1	–	$AX \leftarrow (SP + byte)$			
		[SP+byte], AX	2	1	–	$(SP + byte) \leftarrow AX$			
		AX, word[B]	3	1	4	$AX \leftarrow (B + word)$			
		word[B], AX	3	1	–	$(B + word) \leftarrow AX$			
		AX, ES:word[B]	4	2	5	$AX \leftarrow ((ES, B) + word)$			
		ES:word[B], AX	4	2	–	$((ES, B) + word) \leftarrow AX$			
		AX, word[C]	3	1	4	$AX \leftarrow (C + word)$			
		word[C], AX	3	1	–	$(C + word) \leftarrow AX$			
		AX, ES:word[C]	4	2	5	$AX \leftarrow ((ES, C) + word)$			
		ES:word[C], AX	4	2	–	$((ES, C) + word) \leftarrow AX$			
		AX, word[BC]	3	1	4	$AX \leftarrow (BC + word)$			
		word[BC], AX	3	1	–	$(BC + word) \leftarrow AX$			
AX, ES:word[BC]	4	2	5	$AX \leftarrow ((ES, BC) + word)$					
ES:word[BC], AX	4	2	–	$((ES, BC) + word) \leftarrow AX$					

- Notes 1.** Number of CPU clocks (f_{CLK}) when the internal RAM area, SFR area, or extended SFR area is accessed, or when no data is accessed.
- 2.** Number of CPU clocks (f_{CLK}) when the code flash memory is accessed, or when the data flash memory is accessed by an 8-bit instruction.

Remark Number of clock is when program exists in the internal ROM (flash memory) area. If fetching the instruction from the internal RAM area, the number becomes double number plus 3 clocks at a maximum.

Table 28-5. Operation List (6/17)

Instruction Group	Mnemonic	Operands	Bytes	Clocks		Operation	Flag		
				Note 1	Note 2		Z	AC	CY
16-bit data transfer	MOVW	BC, !addr16	3	1	4	$BC \leftarrow (\text{addr16})$			
		BC, ES:!addr16	4	2	5	$BC \leftarrow (\text{ES}, \text{addr16})$			
		DE, !addr16	3	1	4	$DE \leftarrow (\text{addr16})$			
		DE, ES:!addr16	4	2	5	$DE \leftarrow (\text{ES}, \text{addr16})$			
		HL, !addr16	3	1	4	$HL \leftarrow (\text{addr16})$			
		HL, ES:!addr16	4	2	5	$HL \leftarrow (\text{ES}, \text{addr16})$			
		BC, saddrp	2	1	–	$BC \leftarrow (\text{saddrp})$			
		DE, saddrp	2	1	–	$DE \leftarrow (\text{saddrp})$			
	HL, saddrp	2	1	–	$HL \leftarrow (\text{saddrp})$				
	XCHW	AX, rp ^{Note 3}	1	1	–	$AX \leftrightarrow rp$			
	ONEW	AX	1	1	–	$AX \leftarrow 0001H$			
		BC	1	1	–	$BC \leftarrow 0001H$			
	CLRW	AX	1	1	–	$AX \leftarrow 0000H$			
		BC	1	1	–	$BC \leftarrow 0000H$			
8-bit operation	ADD	A, #byte	2	1	–	$A, CY \leftarrow A + \text{byte}$	x	x	x
		saddr, #byte	3	2	–	$(\text{saddr}), CY \leftarrow (\text{saddr}) + \text{byte}$	x	x	x
		A, r ^{Note 4}	2	1	–	$A, CY \leftarrow A + r$	x	x	x
		r, A	2	1	–	$r, CY \leftarrow r + A$	x	x	x
		A, !addr16	3	1	4	$A, CY \leftarrow A + (\text{addr16})$	x	x	x
		A, ES:!addr16	4	2	5	$A, CY \leftarrow A + (\text{ES}, \text{addr16})$	x	x	x
		A, saddr	2	1	–	$A, CY \leftarrow A + (\text{saddr})$	x	x	x
		A, [HL]	1	1	4	$A, CY \leftarrow A + (\text{HL})$	x	x	x
		A, ES:[HL]	2	2	5	$A, CY \leftarrow A + (\text{ES}, \text{HL})$	x	x	x
		A, [HL+byte]	2	1	4	$A, CY \leftarrow A + (\text{HL} + \text{byte})$	x	x	x
		A, ES:[HL+byte]	3	2	5	$A, CY \leftarrow A + ((\text{ES}, \text{HL}) + \text{byte})$	x	x	x
		A, [HL+B]	2	1	4	$A, CY \leftarrow A + (\text{HL} + B)$	x	x	x
		A, ES:[HL+B]	3	2	5	$A, CY \leftarrow A + ((\text{ES}, \text{HL}) + B)$	x	x	x
		A, [HL+C]	2	1	4	$A, CY \leftarrow A + (\text{HL} + C)$	x	x	x
A, ES:[HL+C]	3	2	5	$A, CY \leftarrow A + ((\text{ES}, \text{HL}) + C)$	x	x	x		

- Notes 1.** Number of CPU clocks (f_{CLK}) when the internal RAM area, SFR area, or extended SFR area is accessed, or when no data is accessed.
- 2.** Number of CPU clocks (f_{CLK}) when the code flash memory is accessed, or when the data flash memory is accessed by an 8-bit instruction.
- 3.** Except $rp = AX$
- 4.** Except $r = A$

Remark Number of clock is when program exists in the internal ROM (flash memory) area. If fetching the instruction from the internal RAM area, the number becomes double number plus 3 clocks at a maximum.

Table 28-5. Operation List (7/17)

Instruction Group	Mnemonic	Operands	Bytes	Clocks		Operation	Flag		
				Note 1	Note 2		Z	AC	CY
8-bit operation	ADDC	A, #byte	2	1	–	$A, CY \leftarrow A + \text{byte} + CY$	x	x	x
		saddr, #byte	3	2	–	$(\text{saddr}), CY \leftarrow (\text{saddr}) + \text{byte} + CY$	x	x	x
		A, r ^{Note 3}	2	1	–	$A, CY \leftarrow A + r + CY$	x	x	x
		r, A	2	1	–	$r, CY \leftarrow r + A + CY$	x	x	x
		A, laddr16	3	1	4	$A, CY \leftarrow A + (\text{addr16}) + CY$	x	x	x
		A, ES:laddr16	4	2	5	$A, CY \leftarrow A + (\text{ES}, \text{addr16}) + CY$	x	x	x
		A, saddr	2	1	–	$A, CY \leftarrow A + (\text{saddr}) + CY$	x	x	x
		A, [HL]	1	1	4	$A, CY \leftarrow A + (\text{HL}) + CY$	x	x	x
		A, ES:[HL]	2	2	5	$A, CY \leftarrow A + (\text{ES}, \text{HL}) + CY$	x	x	x
		A, [HL+byte]	2	1	4	$A, CY \leftarrow A + (\text{HL} + \text{byte}) + CY$	x	x	x
		A, ES:[HL+byte]	3	2	5	$A, CY \leftarrow A + ((\text{ES}, \text{HL}) + \text{byte}) + CY$	x	x	x
		A, [HL+B]	2	1	4	$A, CY \leftarrow A + (\text{HL} + B) + CY$	x	x	x
		A, ES:[HL+B]	3	2	5	$A, CY \leftarrow A + ((\text{ES}, \text{HL}) + B) + CY$	x	x	x
		A, [HL+C]	2	1	4	$A, CY \leftarrow A + (\text{HL} + C) + CY$	x	x	x
	A, ES:[HL+C]	3	2	5	$A, CY \leftarrow A + ((\text{ES}, \text{HL}) + C) + CY$	x	x	x	
	SUB	A, #byte	2	1	–	$A, CY \leftarrow A - \text{byte}$	x	x	x
		saddr, #byte	3	2	–	$(\text{saddr}), CY \leftarrow (\text{saddr}) - \text{byte}$	x	x	x
		A, r ^{Note 3}	2	1	–	$A, CY \leftarrow A - r$	x	x	x
		r, A	2	1	–	$r, CY \leftarrow r - A$	x	x	x
		A, laddr16	3	1	4	$A, CY \leftarrow A - (\text{addr16})$	x	x	x
		A, ES:laddr16	4	2	5	$A, CY \leftarrow A - (\text{ES}, \text{addr16})$	x	x	x
		A, saddr	2	1	–	$A, CY \leftarrow A - (\text{saddr})$	x	x	x
		A, [HL]	1	1	4	$A, CY \leftarrow A - (\text{HL})$	x	x	x
		A, ES:[HL]	2	2	5	$A, CY \leftarrow A - (\text{ES}, \text{HL})$	x	x	x
		A, [HL+byte]	2	1	4	$A, CY \leftarrow A - (\text{HL} + \text{byte})$	x	x	x
		A, ES:[HL+byte]	3	2	5	$A, CY \leftarrow A - ((\text{ES}, \text{HL}) + \text{byte})$	x	x	x
		A, [HL+B]	2	1	4	$A, CY \leftarrow A - (\text{HL} + B)$	x	x	x
		A, ES:[HL+B]	3	2	5	$A, CY \leftarrow A - ((\text{ES}, \text{HL}) + B)$	x	x	x
A, [HL+C]		2	1	4	$A, CY \leftarrow A - (\text{HL} + C)$	x	x	x	
A, ES:[HL+C]	3	2	5	$A, CY \leftarrow A - ((\text{ES}, \text{HL}) + C)$	x	x	x		

- Notes**
1. Number of CPU clocks (f_{CLK}) when the internal RAM area, SFR area, or extended SFR area is accessed, or when no data is accessed.
 2. Number of CPU clocks (f_{CLK}) when the code flash memory is accessed, or when the data flash memory is accessed by an 8-bit instruction.
 3. Except $r = A$

Remark Number of clock is when program exists in the internal ROM (flash memory) area. If fetching the instruction from the internal RAM area, the number becomes double number plus 3 clocks at a maximum.

Table 28-5. Operation List (8/17)

Instruction Group	Mnemonic	Operands	Bytes	Clocks		Operation	Flag		
				Note 1	Note 2		Z	AC	CY
8-bit operation	SUBC	A, #byte	2	1	–	$A, CY \leftarrow A - \text{byte} - CY$	x	x	x
		saddr, #byte	3	2	–	$(\text{saddr}), CY \leftarrow (\text{saddr}) - \text{byte} - CY$	x	x	x
		A, r ^{Note 3}	2	1	–	$A, CY \leftarrow A - r - CY$	x	x	x
		r, A	2	1	–	$r, CY \leftarrow r - A - CY$	x	x	x
		A, laddr16	3	1	4	$A, CY \leftarrow A - (\text{addr16}) - CY$	x	x	x
		A, ES:laddr16	4	2	5	$A, CY \leftarrow A - (\text{ES}, \text{addr16}) - CY$	x	x	x
		A, saddr	2	1	–	$A, CY \leftarrow A - (\text{saddr}) - CY$	x	x	x
		A, [HL]	1	1	4	$A, CY \leftarrow A - (\text{HL}) - CY$	x	x	x
		A, ES:[HL]	2	2	5	$A, CY \leftarrow A - (\text{ES}, \text{HL}) - CY$	x	x	x
		A, [HL+byte]	2	1	4	$A, CY \leftarrow A - (\text{HL} + \text{byte}) - CY$	x	x	x
		A, ES:[HL+byte]	3	2	5	$A, CY \leftarrow A - ((\text{ES}, \text{HL}) + \text{byte}) - CY$	x	x	x
		A, [HL+B]	2	1	4	$A, CY \leftarrow A - (\text{HL} + \text{B}) - CY$	x	x	x
		A, ES:[HL+B]	3	2	5	$A, CY \leftarrow A - ((\text{ES}, \text{HL}) + \text{B}) - CY$	x	x	x
		A, [HL+C]	2	1	4	$A, CY \leftarrow A - (\text{HL} + \text{C}) - CY$	x	x	x
	A, ES:[HL+C]	3	2	5	$A, CY \leftarrow A - ((\text{ES}, \text{HL}) + \text{C}) - CY$	x	x	x	
	AND	A, #byte	2	1	–	$A \leftarrow A \wedge \text{byte}$	x		
		saddr, #byte	3	2	–	$(\text{saddr}) \leftarrow (\text{saddr}) \wedge \text{byte}$	x		
		A, r ^{Note 3}	2	1	–	$A \leftarrow A \wedge r$	x		
		r, A	2	1	–	$R \leftarrow r \wedge A$	x		
		A, laddr16	3	1	4	$A \leftarrow A \wedge (\text{addr16})$	x		
		A, ES:laddr16	4	2	5	$A \leftarrow A \wedge (\text{ES}: \text{addr16})$	x		
		A, saddr	2	1	–	$A \leftarrow A \wedge (\text{saddr})$	x		
		A, [HL]	1	1	4	$A \leftarrow A \wedge (\text{HL})$	x		
		A, ES:[HL]	2	2	5	$A \leftarrow A \wedge (\text{ES}: \text{HL})$	x		
		A, [HL+byte]	2	1	4	$A \leftarrow A \wedge (\text{HL} + \text{byte})$	x		
		A, ES:[HL+byte]	3	2	5	$A \leftarrow A \wedge ((\text{ES}: \text{HL}) + \text{byte})$	x		
		A, [HL+B]	2	1	4	$A \leftarrow A \wedge (\text{HL} + \text{B})$	x		
		A, ES:[HL+B]	3	2	5	$A \leftarrow A \wedge ((\text{ES}: \text{HL}) + \text{B})$	x		
A, [HL+C]		2	1	4	$A \leftarrow A \wedge (\text{HL} + \text{C})$	x			
A, ES:[HL+C]	3	2	5	$A \leftarrow A \wedge ((\text{ES}: \text{HL}) + \text{C})$	x				

- Notes**
1. Number of CPU clocks (f_{CLK}) when the internal RAM area, SFR area, or extended SFR area is accessed, or when no data is accessed.
 2. Number of CPU clocks (f_{CLK}) when the code flash memory is accessed, or when the data flash memory is accessed by an 8-bit instruction.
 3. Except $r = A$

Remark Number of clock is when program exists in the internal ROM (flash memory) area. If fetching the instruction from the internal RAM area, the number becomes double number plus 3 clocks at a maximum.

Table 28-5. Operation List (9/17)

Instruction Group	Mnemonic	Operands	Bytes	Clocks		Operation	Flag		
				Note 1	Note 2		Z	AC	CY
8-bit operation	OR	A, #byte	2	1	–	$A \leftarrow A \vee \text{byte}$		x	
		saddr, #byte	3	2	–	$(\text{saddr}) \leftarrow (\text{saddr}) \vee \text{byte}$		x	
		A, r ^{Note 3}	2	1	–	$A \leftarrow A \vee r$		x	
		r, A	2	1	–	$r \leftarrow r \vee A$		x	
		A, !addr16	3	1	4	$A \leftarrow A \vee (\text{addr}16)$		x	
		A, ES:!addr16	4	2	5	$A \leftarrow A \vee (\text{ES}:\text{addr}16)$		x	
		A, saddr	2	1	–	$A \leftarrow A \vee (\text{saddr})$		x	
		A, [HL]	1	1	4	$A \leftarrow A \vee (\text{H})$		x	
		A, ES:[HL]	2	2	5	$A \leftarrow A \vee (\text{ES}:\text{HL})$		x	
		A, [HL+byte]	2	1	4	$A \leftarrow A \vee (\text{HL}+\text{byte})$		x	
		A, ES:[HL+byte]	3	2	5	$A \leftarrow A \vee ((\text{ES}:\text{HL})+\text{byte})$		x	
		A, [HL+B]	2	1	4	$A \leftarrow A \vee (\text{HL}+\text{B})$		x	
		A, ES:[HL+B]	3	2	5	$A \leftarrow A \vee ((\text{ES}:\text{HL})+\text{B})$		x	
		A, [HL+C]	2	1	4	$A \leftarrow A \vee (\text{HL}+\text{C})$		x	
	A, ES:[HL+C]	3	2	5	$A \leftarrow A \vee ((\text{ES}:\text{HL})+\text{C})$		x		
	XOR	A, #byte	2	1	–	$A \leftarrow A \oplus \text{byte}$		x	
		saddr, #byte	3	2	–	$(\text{saddr}) \leftarrow (\text{saddr}) \oplus \text{byte}$		x	
		A, r ^{Note 3}	2	1	–	$A \leftarrow A \oplus r$		x	
		r, A	2	1	–	$r \leftarrow r \oplus A$		x	
		A, !addr16	3	1	4	$A \leftarrow A \oplus (\text{addr}16)$		x	
		A, ES:!addr16	4	2	5	$A \leftarrow A \oplus (\text{ES}:\text{addr}16)$		x	
		A, saddr	2	1	–	$A \leftarrow A \oplus (\text{saddr})$		x	
		A, [HL]	1	1	4	$A \leftarrow A \oplus (\text{HL})$		x	
		A, ES:[HL]	2	2	5	$A \leftarrow A \oplus (\text{ES}:\text{HL})$		x	
		A, [HL+byte]	2	1	4	$A \leftarrow A \oplus (\text{HL}+\text{byte})$		x	
		A, ES:[HL+byte]	3	2	5	$A \leftarrow A \oplus ((\text{ES}:\text{HL})+\text{byte})$		x	
		A, [HL+B]	2	1	4	$A \leftarrow A \oplus (\text{HL}+\text{B})$		x	
		A, ES:[HL+B]	3	2	5	$A \leftarrow A \oplus ((\text{ES}:\text{HL})+\text{B})$		x	
A, [HL+C]		2	1	4	$A \leftarrow A \oplus (\text{HL}+\text{C})$		x		
A, ES:[HL+C]	3	2	5	$A \leftarrow A \oplus ((\text{ES}:\text{HL})+\text{C})$		x			

- Notes**
1. Number of CPU clocks (f_{CLK}) when the internal RAM area, SFR area, or extended SFR area is accessed, or when no data is accessed.
 2. Number of CPU clocks (f_{CLK}) when the code flash memory is accessed, or when the data flash memory is accessed by an 8-bit instruction.
 3. Except $r = A$

Remark Number of clock is when program exists in the internal ROM (flash memory) area. If fetching the instruction from the internal RAM area, the number becomes double number plus 3 clocks at a maximum.

Table 28-5. Operation List (10/17)

Instruction Group	Mnemonic	Operands	Bytes	Clocks		Operation	Flag		
				Note 1	Note 2		Z	AC	CY
8-bit operation	CMP	A, #byte	2	1	–	A – byte	x	x	x
		!addr16, #byte	4	1	4	(addr16) – byte	x	x	x
		ES:!addr16, #byte	5	2	5	(ES:addr16) – byte	x	x	x
		saddr, #byte	3	1	–	(saddr) – byte	x	x	x
		A, r ^{Note3}	2	1	–	A – r	x	x	x
		r, A	2	1	–	r – A	x	x	x
		A, !addr16	3	1	4	A – (addr16)	x	x	x
		A, ES:!addr16	4	2	5	A – (ES:addr16)	x	x	x
		A, saddr	2	1	–	A – (saddr)	x	x	x
		A, [HL]	1	1	4	A – (HL)	x	x	x
		A, ES:[HL]	2	2	5	A – (ES:HL)	x	x	x
		A, [HL+byte]	2	1	4	A – (HL+byte)	x	x	x
		A, ES:[HL+byte]	3	2	5	A – ((ES:HL)+byte)	x	x	x
		A, [HL+B]	2	1	4	A – (HL+B)	x	x	x
		A, ES:[HL+B]	3	2	5	A – ((ES:HL)+B)	x	x	x
		A, [HL+C]	2	1	4	A – (HL+C)	x	x	x
	A, ES:[HL+C]	3	2	5	A – ((ES:HL)+C)	x	x	x	
	CMP0	A	1	1	–	A – 00H	x	0	0
		X	1	1	–	X – 00H	x	0	0
		B	1	1	–	B – 00H	x	0	0
		C	1	1	–	C – 00H	x	0	0
		!addr16	3	1	4	(addr16) – 00H	x	0	0
		ES:!addr16	4	2	5	(ES:addr16) – 00H	x	0	0
		saddr	2	1	–	(saddr) – 00H	x	0	0
	CMPS	X, [HL+byte]	3	1	4	X – (HL+byte)	x	x	x
		X, ES:[HL+byte]	4	2	5	X – ((ES:HL)+byte)	x	x	x

- Notes**
1. Number of CPU clocks (f_{CLK}) when the internal RAM area, SFR area, or extended SFR area is accessed, or when no data is accessed.
 2. Number of CPU clocks (f_{CLK}) when the code flash memory is accessed, or when the data flash memory is accessed by an 8-bit instruction.
 3. Except r = A

Remark Number of clock is when program exists in the internal ROM (flash memory) area. If fetching the instruction from the internal RAM area, the number becomes double number plus 3 clocks at a maximum.

Table 28-5. Operation List (11/17)

Instruction Group	Mnemonic	Operands	Bytes	Clocks		Operation	Flag		
				Note 1	Note 2		Z	AC	CY
16-bit operation	ADDW	AX, #word	3	1	–	AX, CY ← AX+word	x	x	x
		AX, AX	1	1	–	AX, CY ← AX+AX	x	x	x
		AX, BC	1	1	–	AX, CY ← AX+BC	x	x	x
		AX, DE	1	1	–	AX, CY ← AX+DE	x	x	x
		AX, HL	1	1	–	AX, CY ← AX+HL	x	x	x
		AX, !addr16	3	1	4	AX, CY ← AX+(addr16)	x	x	x
		AX, ES:!addr16	4	2	5	AX, CY ← AX+(ES:addr16)	x	x	x
		AX, saddrp	2	1	–	AX, CY ← AX+(saddrp)	x	x	x
		AX, [HL+byte]	3	1	4	AX, CY ← AX+(HL+byte)	x	x	x
		AX, ES: [HL+byte]	4	2	5	AX, CY ← AX+((ES:HL)+byte)	x	x	x
	SUBW	AX, #word	3	1	–	AX, CY ← AX – word	x	x	x
		AX, BC	1	1	–	AX, CY ← AX – BC	x	x	x
		AX, DE	1	1	–	AX, CY ← AX – DE	x	x	x
		AX, HL	1	1	–	AX, CY ← AX – HL	x	x	x
		AX, !addr16	3	1	4	AX, CY ← AX – (addr16)	x	x	x
		AX, ES:!addr16	4	2	5	AX, CY ← AX – (ES:addr16)	x	x	x
		AX, saddrp	2	1	–	AX, CY ← AX – (saddrp)	x	x	x
		AX, [HL+byte]	3	1	4	AX, CY ← AX – (HL+byte)	x	x	x
		AX, ES: [HL+byte]	4	2	5	AX, CY ← AX – ((ES:HL)+byte)	x	x	x
	CMPW	AX, #word	3	1	–	AX – word	x	x	x
		AX, BC	1	1	–	AX – BC	x	x	x
		AX, DE	1	1	–	AX – DE	x	x	x
		AX, HL	1	1	–	AX – HL	x	x	x
		AX, !addr16	3	1	4	AX – (addr16)	x	x	x
		AX, ES:!addr16	4	2	5	AX – (ES:addr16)	x	x	x
		AX, saddrp	2	1	–	AX – (saddrp)	x	x	x
		AX, [HL+byte]	3	1	4	AX – (HL+byte)	x	x	x
AX, ES: [HL+byte]		4	2	5	AX – ((ES:HL)+byte)	x	x	x	
Multiply	MULU	X	1	1	–	AX ← A×X			

- Notes 1.** Number of CPU clocks (f_{CLK}) when the internal RAM area, SFR area, or extended SFR area is accessed, or when no data is accessed.
- 2.** Number of CPU clocks (f_{CLK}) when the code flash memory is accessed, or when the data flash memory is accessed by an 8-bit instruction.

Remark Number of clock is when program exists in the internal ROM (flash memory) area. If fetching the instruction from the internal RAM area, the number becomes double number plus 3 clocks at a maximum.

Table 28-5. Operation List (12/17)

Instruction Group	Mnemonic	Operands	Bytes	Clocks		Operation	Flag		
				Note 1	Note 2		Z	AC	CY
Increment/ decrement	INC	r	1	1	–	$r \leftarrow r+1$	x	x	
		laddr16	3	2	–	$(addr16) \leftarrow (addr16)+1$	x	x	
		ES:laddr16	4	3	–	$(ES, addr16) \leftarrow (ES, addr16)+1$	x	x	
		saddr	2	2	–	$(saddr) \leftarrow (saddr)+1$	x	x	
		[HL+byte]	3	2	–	$(HL+byte) \leftarrow (HL+byte)+1$	x	x	
		ES: [HL+byte]	4	3	–	$((ES:HL)+byte) \leftarrow ((ES:HL)+byte)+1$	x	x	
	DEC	r	1	1	–	$r \leftarrow r - 1$	x	x	
		laddr16	3	2	–	$(addr16) \leftarrow (addr16) - 1$	x	x	
		ES:laddr16	4	3	–	$(ES, addr16) \leftarrow (ES, addr16) - 1$	x	x	
		saddr	2	2	–	$(saddr) \leftarrow (saddr) - 1$	x	x	
		[HL+byte]	3	2	–	$(HL+byte) \leftarrow (HL+byte) - 1$	x	x	
		ES: [HL+byte]	4	3	–	$((ES:HL)+byte) \leftarrow ((ES:HL)+byte) - 1$	x	x	
	INCW	rp	1	1	–	$rp \leftarrow rp+1$			
		laddr16	3	2	–	$(addr16) \leftarrow (addr16)+1$			
		ES:laddr16	4	3	–	$(ES, addr16) \leftarrow (ES, addr16)+1$			
		saddrp	2	2	–	$(saddrp) \leftarrow (saddrp)+1$			
		[HL+byte]	3	2	–	$(HL+byte) \leftarrow (HL+byte)+1$			
		ES: [HL+byte]	4	3	–	$((ES:HL)+byte) \leftarrow ((ES:HL)+byte)+1$			
	DECW	rp	1	1	–	$rp \leftarrow rp - 1$			
		laddr16	3	2	–	$(addr16) \leftarrow (addr16) - 1$			
		ES:laddr16	4	3	–	$(ES, addr16) \leftarrow (ES, addr16) - 1$			
		saddrp	2	2	–	$(saddrp) \leftarrow (saddrp) - 1$			
		[HL+byte]	3	2	–	$(HL+byte) \leftarrow (HL+byte) - 1$			
		ES: [HL+byte]	4	3	–	$((ES:HL)+byte) \leftarrow ((ES:HL)+byte) - 1$			
Shift	SHR	A, cnt	2	1	–	$(CY \leftarrow A_0, A_{m-1} \leftarrow A_m, A_7 \leftarrow 0) \times cnt$			x
	SHRW	AX, cnt	2	1	–	$(CY \leftarrow AX_0, AX_{m-1} \leftarrow AX_m, AX_{15} \leftarrow 0) \times cnt$			x
	SHL	A, cnt	2	1	–	$(CY \leftarrow A_7, A_m \leftarrow A_{m-1}, A_0 \leftarrow 0) \times cnt$			x
		B, cnt	2	1	–	$(CY \leftarrow B_7, B_m \leftarrow B_{m-1}, B_0 \leftarrow 0) \times cnt$			x
		C, cnt	2	1	–	$(CY \leftarrow C_7, C_m \leftarrow C_{m-1}, C_0 \leftarrow 0) \times cnt$			x
	SHLW	AX, cnt	2	1	–	$(CY \leftarrow AX_{15}, AX_m \leftarrow AX_{m-1}, AX_0 \leftarrow 0) \times cnt$			x
		BC, cnt	2	1	–	$(CY \leftarrow BC_{15}, BC_m \leftarrow BC_{m-1}, BC_0 \leftarrow 0) \times cnt$			x
	SAR	A, cnt	2	1	–	$(CY \leftarrow A_0, A_{m-1} \leftarrow A_m, A_7 \leftarrow A_7) \times cnt$			x
SARW	AX, cnt	2	1	–	$(CY \leftarrow AX_0, AX_{m-1} \leftarrow AX_m, AX_{15} \leftarrow AX_{15}) \times cnt$			x	

- Notes 1.** Number of CPU clocks (f_{CLK}) when the internal RAM area, SFR area, or extended SFR area is accessed, or when no data is accessed.
- 2.** Number of CPU clocks (f_{CLK}) when the code flash memory is accessed, or when the data flash memory is accessed by an 8-bit instruction.

- Remarks 1.** Number of clock is when program exists in the internal ROM (flash memory) area. If fetching the instruction from the internal RAM area, the number becomes double number plus 3 clocks at a maximum.
- 2.** cnt indicates the bit shift count.

Table 28-5. Operation List (13/17)

Instruction Group	Mnemonic	Operands	Bytes	Clocks		Operation	Flag		
				Note 1	Note 2		Z	AC	CY
Rotate	ROR	A, 1	2	1	–	$(CY, A_7 \leftarrow A_0, A_{m-1} \leftarrow A_m) \times 1$			x
	ROL	A, 1	2	1	–	$(CY, A_0 \leftarrow A_7, A_{m+1} \leftarrow A_m) \times 1$			x
	RORC	A, 1	2	1	–	$(CY \leftarrow A_0, A_7 \leftarrow CY, A_{m-1} \leftarrow A_m) \times 1$			x
	ROLC	A, 1	2	1	–	$(CY \leftarrow A_7, A_0 \leftarrow CY, A_{m+1} \leftarrow A_m) \times 1$			x
	ROLWC	AX,1	2	1	–	$(CY \leftarrow AX_{15}, AX_0 \leftarrow CY, AX_{m+1} \leftarrow AX_m) \times 1$			x
		BC,1	2	1	–	$(CY \leftarrow BC_{15}, BC_0 \leftarrow CY, BC_{m+1} \leftarrow BC_m) \times 1$			x
Bit manipulate	MOV1	CY, A.bit	2	1	–	$CY \leftarrow A.bit$			x
		A.bit, CY	2	1	–	$A.bit \leftarrow CY$			
		CY, PSW.bit	3	1	–	$CY \leftarrow PSW.bit$			x
		PSW.bit, CY	3	4	–	$PSW.bit \leftarrow CY$	x	x	
		CY, saddr.bit	3	1	–	$CY \leftarrow (saddr).bit$			x
		saddr.bit, CY	3	2	–	$(saddr).bit \leftarrow CY$			
		CY, sfr.bit	3	1	–	$CY \leftarrow sfr.bit$			x
		sfr.bit, CY	3	2	–	$sfr.bit \leftarrow CY$			
		CY, [HL].bit	2	1	4	$CY \leftarrow (HL).bit$			x
		[HL].bit, CY	2	2	–	$(HL).bit \leftarrow CY$			
	AND1	CY, A.bit	2	1	–	$CY \leftarrow CY \wedge A.bit$			x
		CY, PSW.bit	3	1	–	$CY \leftarrow CY \wedge PSW.bit$			x
		CY, saddr.bit	3	1	–	$CY \leftarrow CY \wedge (saddr).bit$			x
		CY, sfr.bit	3	1	–	$CY \leftarrow CY \wedge sfr.bit$			x
		CY, [HL].bit	2	1	4	$CY \leftarrow CY \wedge (HL).bit$			x
		CY, ES:[HL].bit	3	2	5	$CY \leftarrow CY \wedge (ES, HL).bit$			x
	OR1	CY, A.bit	2	1	–	$CY \leftarrow CY \vee A.bit$			x
		CY, PSW.bit	3	1	–	$CY \leftarrow CY \vee PSW.bit$			x
		CY, saddr.bit	3	1	–	$CY \leftarrow CY \vee (saddr).bit$			x
		CY, sfr.bit	3	1	–	$CY \leftarrow CY \vee sfr.bit$			x
		CY, [HL].bit	2	1	4	$CY \leftarrow CY \vee (HL).bit$			x
		CY, ES:[HL].bit	3	2	5	$CY \leftarrow CY \vee (ES, HL).bit$			x

- Notes 1.** Number of CPU clocks (f_{CLK}) when the internal RAM area, SFR area, or extended SFR area is accessed, or when no data is accessed.
- 2.** Number of CPU clocks (f_{CLK}) when the code flash memory is accessed, or when the data flash memory is accessed by an 8-bit instruction.

Remark Number of clock is when program exists in the internal ROM (flash memory) area. If fetching the instruction from the internal RAM area, the number becomes double number plus 3 clocks at a maximum.

Table 28-5. Operation List (14/17)

Instruction Group	Mnemonic	Operands	Bytes	Clocks		Operation	Flag		
				Note 1	Note 2		Z	AC	CY
Bit manipulate	XOR1	CY, A.bit	2	1	–	$CY \leftarrow CY \nabla A.bit$			x
		CY, PSW.bit	3	1	–	$CY \leftarrow CY \nabla PSW.bit$			x
		CY, saddr.bit	3	1	–	$CY \leftarrow CY \nabla (saddr).bit$			x
		CY, sfr.bit	3	1	–	$CY \leftarrow CY \nabla sfr.bit$			x
		CY, [HL].bit	2	1	4	$CY \leftarrow CY \nabla (HL).bit$			x
		CY, ES:[HL].bit	3	2	5	$CY \leftarrow CY \nabla (ES, HL).bit$			x
	SET1	A.bit	2	1	–	$A.bit \leftarrow 1$			
		PSW.bit	3	4	–	$PSW.bit \leftarrow 1$	x	x	x
		!addr16.bit	4	2	–	$(addr16).bit \leftarrow 1$			
		ES:!addr16.bit	5	3	–	$(ES, addr16).bit \leftarrow 1$			
		saddr.bit	3	2	–	$(saddr).bit \leftarrow 1$			
		sfr.bit	3	2	–	$sfr.bit \leftarrow 1$			
		[HL].bit	2	2	–	$(HL).bit \leftarrow 1$			
		ES:[HL].bit	3	3	–	$(ES, HL).bit \leftarrow 1$			
	CLR1	A.bit	2	1	–	$A.bit \leftarrow 0$			
		PSW.bit	3	4	–	$PSW.bit \leftarrow 0$	x	x	x
		!addr16.bit	4	2	–	$(addr16).bit \leftarrow 0$			
		ES:!addr16.bit	5	3	–	$(ES, addr16).bit \leftarrow 0$			
		saddr.bit	3	2	–	$(saddr).bit \leftarrow 0$			
		sfr.bit	3	2	–	$sfr.bit \leftarrow 0$			
		[HL].bit	2	2	–	$(HL).bit \leftarrow 0$			
		ES:[HL].bit	3	3	–	$(ES, HL).bit \leftarrow 0$			
	SET1	CY	2	1	–	$CY \leftarrow 1$			1
	CLR1	CY	2	1	–	$CY \leftarrow 0$			0
	NOT1	CY	2	1	–	$CY \leftarrow \overline{CY}$			x

- Notes 1.** Number of CPU clocks (f_{CLK}) when the internal RAM area, SFR area, or extended SFR area is accessed, or when no data is accessed
- 2.** Number of CPU clocks (f_{CLK}) when the code flash memory is accessed, or when the data flash memory is accessed by an 8-bit instruction.

Remark Number of clock is when program exists in the internal ROM (flash memory) area. If fetching the instruction from the internal RAM area, the number becomes double number plus 3 clocks at a maximum.

Table 28-5. Operation List (15/17)

Instruction Group	Mnemonic	Operands	Bytes	Clocks		Operation	Flag		
				Note 1	Note 2		Z	AC	CY
Call/ return	CALL	rp	2	3	–	$(SP - 2) \leftarrow (PC+2)_S, (SP - 3) \leftarrow (PC+2)_H,$ $(SP - 4) \leftarrow (PC+2)_L, PC \leftarrow CS, rp,$ $SP \leftarrow SP - 4$			
		\$!addr20	3	3	–	$(SP - 2) \leftarrow (PC+3)_S, (SP - 3) \leftarrow (PC+3)_H,$ $(SP - 4) \leftarrow (PC+3)_L, PC \leftarrow PC+3+jdisp16,$ $SP \leftarrow SP - 4$			
		!addr16	3	3	–	$(SP - 2) \leftarrow (PC+3)_S, (SP - 3) \leftarrow (PC+3)_H,$ $(SP - 4) \leftarrow (PC+3)_L, PC \leftarrow 0000, addr16,$ $SP \leftarrow SP - 4$			
		!!addr20	4	3	–	$(SP - 2) \leftarrow (PC+4)_S, (SP - 3) \leftarrow (PC+4)_H,$ $(SP - 4) \leftarrow (PC+4)_L, PC \leftarrow addr20,$ $SP \leftarrow SP - 4$			
	CALLT	[addr5]	2	5	–	$(SP - 2) \leftarrow (PC+2)_S, (SP - 3) \leftarrow (PC+2)_H,$ $(SP - 4) \leftarrow (PC+2)_L, PC_S \leftarrow 0000,$ $PC_H \leftarrow (0000, addr5+1),$ $PC_L \leftarrow (0000, addr5),$ $SP \leftarrow SP - 4$			
	BRK	–	2	5	–	$(SP - 1) \leftarrow PSW, (SP - 2) \leftarrow (PC+2)_S,$ $(SP - 3) \leftarrow (PC+2)_H, (SP - 4) \leftarrow (PC+2)_L,$ $PC_S \leftarrow 0000,$ $PC_H \leftarrow (0007FH), PC_L \leftarrow (0007EH),$ $SP \leftarrow SP - 4, IE \leftarrow 0$			
	RET	–	1	6	–	$PC_L \leftarrow (SP), PC_H \leftarrow (SP+1),$ $PC_S \leftarrow (SP+2), SP \leftarrow SP+4$			
RETI	–	2	6	–	$PC_L \leftarrow (SP), PC_H \leftarrow (SP+1),$ $PC_S \leftarrow (SP+2), PSW \leftarrow (SP+3),$ $SP \leftarrow SP+4$	R	R	R	
RETB	–	2	6	–	$PC_L \leftarrow (SP), PC_H \leftarrow (SP+1),$ $PC_S \leftarrow (SP+2), PSW \leftarrow (SP+3),$ $SP \leftarrow SP+4$	R	R	R	

Notes 1. Number of CPU clocks (f_{CLK}) when the internal RAM area, SFR area, or extended SFR area is accessed, or when no data is accessed.

- 2.** Number of CPU clocks (f_{CLK}) when the code flash memory is accessed, or when the data flash memory is accessed by an 8-bit instruction.

Remark Number of clock is when program exists in the internal ROM (flash memory) area. If fetching the instruction from the internal RAM area, the number becomes double number plus 3 clocks at a maximum.

Table 28-5. Operation List (16/17)

Instruction Group	Mnemonic	Operands	Bytes	Clocks		Operation	Flag		
				Note 1	Note 2		Z	AC	CY
Stack manipulate	PUSH	PSW	2	1	–	$(SP - 1) \leftarrow PSW, (SP - 2) \leftarrow 00H,$ $SP \leftarrow SP - 2$			
		rp	1	1	–	$(SP - 1) \leftarrow rpH, (SP - 2) \leftarrow rpL,$ $SP \leftarrow SP - 2$			
	POP	PSW	2	3	–	$PSW \leftarrow (SP + 1), SP \leftarrow SP + 2$	R	R	R
		rp	1	1	–	$rpL \leftarrow (SP), rpH \leftarrow (SP + 1), SP \leftarrow SP + 2$			
	MOVW	SP, #word	4	1	–	$SP \leftarrow word$			
		SP, AX	2	1	–	$SP \leftarrow AX$			
		AX, SP	2	1	–	$AX \leftarrow SP$			
		HL, SP	3	1	–	$HL \leftarrow SP$			
		BC, SP	3	1	–	$BC \leftarrow SP$			
		DE, SP	3	1	–	$DE \leftarrow SP$			
	ADDW	SP, #byte	2	1	–	$SP \leftarrow SP + byte$			
SUBW	SP, #byte	2	1	–	$SP \leftarrow SP - byte$				
Unconditional branch	BR	AX	2	3	–	$PC \leftarrow CS, AX$			
		\$addr20	2	3	–	$PC \leftarrow PC + 2 + jdisp8$			
		!addr20	3	3	–	$PC \leftarrow PC + 3 + jdisp16$			
		!addr16	3	3	–	$PC \leftarrow 0000, addr16$			
		!!addr20	4	3	–	$PC \leftarrow addr20$			
Conditional branch	BC	\$addr20	2	2/4 Note3	–	$PC \leftarrow PC + 2 + jdisp8$ if CY = 1			
	BNC	\$addr20	2	2/4 Note3	–	$PC \leftarrow PC + 2 + jdisp8$ if CY = 0			
	BZ	\$addr20	2	2/4 Note3	–	$PC \leftarrow PC + 2 + jdisp8$ if Z = 1			
	BNZ	\$addr20	2	2/4 Note3	–	$PC \leftarrow PC + 2 + jdisp8$ if Z = 0			
	BH	\$addr20	3	2/4 Note3	–	$PC \leftarrow PC + 3 + jdisp8$ if $(Z \vee CY) = 0$			
	BNH	\$addr20	3	2/4 Note3	–	$PC \leftarrow PC + 3 + jdisp8$ if $(Z \vee CY) = 1$			
	BT	saddr.bit, \$addr20	4	3/5 Note3	–	$PC \leftarrow PC + 4 + jdisp8$ if saddr.bit = 1			
		sfr.bit, \$addr20	4	3/5 Note3	–	$PC \leftarrow PC + 4 + jdisp8$ if sfr.bit = 1			
		A.bit, \$addr20	3	3/5 Note3	–	$PC \leftarrow PC + 3 + jdisp8$ if A.bit = 1			
		PSW.bit, \$addr20	4	3/5 Note3	–	$PC \leftarrow PC + 4 + jdisp8$ if PSW.bit = 1			
		[HL].bit, \$addr20	3	3/5 Note3	6/7	$PC \leftarrow PC + 3 + jdisp8$ if (HL).bit = 1			
ES:[HL].bit, \$addr20	4	4/6 Note3	7/8	$PC \leftarrow PC + 4 + jdisp8$ if (ES, HL).bit = 1					

- Notes 1.** Number of CPU clocks (f_{CLK}) when the internal RAM area, SFR area, or extended SFR area is accessed, or when no data is accessed.
- 2.** Number of CPU clocks (f_{CLK}) when the code flash memory is accessed, or when the data flash memory is accessed by an 8-bit instruction.
- 3.** This indicates the number of clocks “when condition is not met/when condition is met”.

Remark Number of clock is when program exists in the internal ROM (flash memory) area. If fetching the instruction from the internal RAM area, the number becomes double number plus 3 clocks at a maximum.

Table 28-5. Operation List (17/17)

Instruction Group	Mnemonic	Operands	Bytes	Clocks		Operation	Flag		
				Note 1	Note 2		Z	AC	CY
Conditional branch	BF	saddr.bit, \$addr20	4	3/5 ^{Note3}	–	PC ← PC + 4 + jdisp8 if (saddr).bit = 0			
		sfr.bit, \$addr20	4	3/5 ^{Note3}	–	PC ← PC + 4 + jdisp8 if sfr.bit = 0			
		A.bit, \$addr20	3	3/5 ^{Note3}	–	PC ← PC + 3 + jdisp8 if A.bit = 0			
		PSW.bit, \$addr20	4	3/5 ^{Note3}	–	PC ← PC + 4 + jdisp8 if PSW.bit = 0			
		[HL].bit, \$addr20	3	3/5 ^{Note3}	6/7	PC ← PC + 3 + jdisp8 if (HL).bit = 0			
		ES:[HL].bit, \$addr20	4	4/6 ^{Note3}	7/8	PC ← PC + 4 + jdisp8 if (ES, HL).bit = 0			
	BTCLR	saddr.bit, \$addr20	4	3/5 ^{Note3}	–	PC ← PC + 4 + jdisp8 if (saddr).bit = 1 then reset (saddr).bit			
		sfr.bit, \$addr20	4	3/5 ^{Note3}	–	PC ← PC + 4 + jdisp8 if sfr.bit = 1 then reset sfr.bit			
		A.bit, \$addr20	3	3/5 ^{Note3}	–	PC ← PC + 3 + jdisp8 if A.bit = 1 then reset A.bit			
		PSW.bit, \$addr20	4	3/5 ^{Note3}	–	PC ← PC + 4 + jdisp8 if PSW.bit = 1 then reset PSW.bit	x	x	x
		[HL].bit, \$addr20	3	3/5 ^{Note3}	–	PC ← PC + 3 + jdisp8 if (HL).bit = 1 then reset (HL).bit			
		ES:[HL].bit, \$addr20	4	4/6 ^{Note3}	–	PC ← PC + 4 + jdisp8 if (ES, HL).bit = 1 then reset (ES, HL).bit			
Conditional skip	SKC	–	2	1	–	Next instruction skip if CY = 1			
	SKNC	–	2	1	–	Next instruction skip if CY = 0			
	SKZ	–	2	1	–	Next instruction skip if Z = 1			
	SKNZ	–	2	1	–	Next instruction skip if Z = 0			
	SKH	–	2	1	–	Next instruction skip if (Z∨CY)=0			
	SKNH	–	2	1	–	Next instruction skip if (Z∨CY)=1			
CPU control	SEL ^{Note4}	RBn	2	1	–	RBS[1:0] ← n			
	NOP	–	1	1	–	No Operation			
	EI	–	3	4	–	IE ← 1 (Enable Interrupt)			
	DI	–	3	4	–	IE ← 0 (Disable Interrupt)			
	HALT	–	2	3	–	Set HALT Mode			
	STOP	–	2	3	–	Set STOP Mode			

- Notes 1.** Number of CPU clocks (f_{CLK}) when the internal RAM area, SFR area, or extended SFR area is accessed, or when no data is accessed.
- 2.** Number of CPU clocks (f_{CLK}) when the code flash memory is accessed, or when the data flash memory is accessed by an 8-bit instruction.
- 3.** This indicates the number of clocks “when condition is not met/when condition is met”.
- 4.** n indicates the number of register banks (n = 0 to 3).

Remark Number of clock is when program exists in the internal ROM (flash memory) area. If fetching the instruction from the internal RAM area, the number becomes double number plus 3 clocks at a maximum.

CHAPTER 29 ELECTRICAL SPECIFICATIONS ($T_A = -40$ to $+85^\circ\text{C}$)

This chapter describes the following electrical specifications.

Target products A: Consumer applications $T_A = -40$ to $+85^\circ\text{C}$

R5F100xxAxx, R5F101xxAxx

D: Industrial applications $T_A = -40$ to $+85^\circ\text{C}$

R5F100xxDxx, R5F101xxDxx

G: Industrial applications when $T_A = -40$ to $+105^\circ\text{C}$ products is used in the range of $T_A = -40$ to $+85^\circ\text{C}$

R5F100xxGxx

- Cautions**
- 1. The RL78 microcontrollers have an on-chip debug function, which is provided for development and evaluation. Do not use the on-chip debug function in products designated for mass production, because the guaranteed number of rewritable times of the flash memory may be exceeded when this function is used, and product reliability therefore cannot be guaranteed. Renesas Electronics is not liable for problems occurring when the on-chip debug function is used.**
 - 2. With products not provided with an EV_{DD0} , EV_{DD1} , EV_{SS0} , or EV_{SS1} pin, replace EV_{DD0} and EV_{DD1} with V_{DD} , or replace EV_{SS0} and EV_{SS1} with V_{SS} .**
 - 3. The pins mounted depend on the product. Refer to 2.1 Port Function to 2.2.1 Functions for each product.**

29.1 Absolute Maximum Ratings

Absolute Maximum Ratings (T_A = 25°C) (1/2)

Parameter	Symbols	Conditions	Ratings	Unit
Supply voltage	V _{DD}		-0.5 to +6.5	V
	EV _{DD0} , EV _{DD1}	EV _{DD0} = EV _{DD1}	-0.5 to +6.5	V
	EV _{SS0} , EV _{SS1}	EV _{SS0} = EV _{SS1}	-0.5 to +0.3	V
REGC pin input voltage	V _{I_{REGC}}	REGC	-0.3 to +2.8 and -0.3 to V _{DD} +0.3 ^{Note 1}	V
Input voltage	V _{I1}	P00 to P07, P10 to P17, P30 to P37, P40 to P47, P50 to P57, P64 to P67, P70 to P77, P80 to P87, P90 to P97, P100 to P106, P110 to P117, P120, P125 to P127, P140 to P147	-0.3 to EV _{DD0} +0.3 and -0.3 to V _{DD} +0.3 ^{Note 2}	V
	V _{I2}	P60 to P63 (N-ch open-drain)	-0.3 to +6.5	V
	V _{I3}	P20 to P27, P121 to P124, P137, P150 to P156, EXCLK, EXCLKS, RESET	-0.3 to V _{DD} +0.3 ^{Note 2}	V
Output voltage	V _{O1}	P00 to P07, P10 to P17, P30 to P37, P40 to P47, P50 to P57, P60 to P67, P70 to P77, P80 to P87, P90 to P97, P100 to P106, P110 to P117, P120, P125 to P127, P130, P140 to P147	-0.3 to EV _{DD0} +0.3 and -0.3 to V _{DD} +0.3 ^{Note 2}	V
	V _{O2}	P20 to P27, P150 to P156	-0.3 to V _{DD} +0.3 ^{Note 2}	V
Analog input voltage	V _{A11}	ANI16 to ANI26	-0.3 to EV _{DD0} +0.3 and -0.3 to AV _{REF} (+) +0.3 ^{Notes 2, 3}	V
	V _{A12}	ANI0 to ANI14	-0.3 to V _{DD} +0.3 and -0.3 to AV _{REF} (+) +0.3 ^{Notes 2, 3}	V

Notes 1. Connect the REGC pin to V_{SS} via a capacitor (0.47 to 1 μF). This value regulates the absolute maximum rating of the REGC pin. Do not use this pin with voltage applied to it.

2. Must be 6.5 V or lower.

3. Do not exceed AV_{REF}(+) + 0.3 V in case of A/D conversion target pin.

Caution Product quality may suffer if the absolute maximum rating is exceeded even momentarily for any parameter. That is, the absolute maximum ratings are rated values at which the product is on the verge of suffering physical damage, and therefore the product must be used under conditions that ensure that the absolute maximum ratings are not exceeded.

Remarks 1. Unless specified otherwise, the characteristics of alternate-function pins are the same as those of the port pins.

2. AV_{REF}(+) : + side reference voltage of the A/D converter.

3. V_{SS} : Reference voltage

Absolute Maximum Ratings (T_A = 25°C) (2/2)

Parameter	Symbols	Conditions		Ratings	Unit
Output current, high	I _{OH1}	Per pin	P00 to P07, P10 to P17, P30 to P37, P40 to P47, P50 to P57, P64 to P67, P70 to P77, P80 to P87, P90 to P97, P100 to P106, P110 to P117, P120, P125 to P127, P130, P140 to P147	-40	mA
		Total of all pins -170 mA	P00 to P04, P07, P32 to P37, P40 to P47, P102 to P106, P120, P125 to P127, P130, P140 to P145	-70	mA
			P05, P06, P10 to P17, P30, P31, P50 to P57, P64 to P67, P70 to P77, P80 to P87, P90 to P97, P100, P101, P110 to P117, P146, P147	-100	mA
	I _{OH2}	Per pin	P20 to P27, P150 to P156	-0.5	mA
		Total of all pins		-2	mA
	Output current, low	I _{OL1}	Per pin	P00 to P07, P10 to P17, P30 to P37, P40 to P47, P50 to P57, P60 to P67, P70 to P77, P80 to P87, P90 to P97, P100 to P106, P110 to P117, P120, P125 to P127, P130, P140 to P147	40
Total of all pins 170 mA			P00 to P04, P07, P32 to P37, P40 to P47, P102 to P106, P120, P125 to P127, P130, P140 to P145	70	mA
			P05, P06, P10 to P17, P30, P31, P50 to P57, P60 to P67, P70 to P77, P80 to P87, P90 to P97, P100, P101, P110 to P117, P146, P147	100	mA
I _{OL2}		Per pin	P20 to P27, P150 to P156	1	mA
		Total of all pins		5	mA
Operating ambient temperature		T _A	In normal operation mode	-40 to +85	°C
	In flash memory programming mode				
Storage temperature	T _{stg}		-65 to +150	°C	

Caution Product quality may suffer if the absolute maximum rating is exceeded even momentarily for any parameter. That is, the absolute maximum ratings are rated values at which the product is on the verge of suffering physical damage, and therefore the product must be used under conditions that ensure that the absolute maximum ratings are not exceeded.

Remark Unless specified otherwise, the characteristics of alternate-function pins are the same as those of the port pins.

29.2 Oscillator Characteristics

29.2.1 X1, XT1 oscillator characteristics

(T_A = -40 to +85°C, 1.6 V ≤ V_{DD} ≤ 5.5 V, V_{SS} = 0 V)

Parameter	Resonator	Conditions	MIN.	TYP.	MAX.	Unit
X1 clock oscillation frequency (f _x) ^{Note}	Ceramic resonator/ crystal resonator	2.7 V ≤ V _{DD} ≤ 5.5 V	1.0		20.0	MHz
		2.4 V ≤ V _{DD} < 2.7 V	1.0		16.0	MHz
		1.8 V ≤ V _{DD} < 2.4 V	1.0		8.0	MHz
		1.6 V ≤ V _{DD} < 1.8 V	1.0		4.0	MHz
XT1 clock oscillation frequency (f _x) ^{Note}	Crystal resonator		32	32.768	35	kHz

Note Indicates only permissible oscillator frequency ranges. Refer to AC Characteristics for instruction execution time. Request evaluation by the manufacturer of the oscillator circuit mounted on a board to check the oscillator characteristics.

Caution Since the CPU is started by the high-speed on-chip oscillator clock after a reset release, check the X1 clock oscillation stabilization time using the oscillation stabilization time counter status register (OSTC) by the user. Determine the oscillation stabilization time of the OSTC register and the oscillation stabilization time select register (OSTS) after sufficiently evaluating the oscillation stabilization time with the resonator to be used.

Remark When using the X1 oscillator and XT1 oscillator, refer to 5.4 System Clock Oscillator.

29.2.2 On-chip oscillator characteristics

(T_A = -40 to +85°C, 1.6 V ≤ V_{DD} ≤ 5.5 V, V_{SS} = 0 V)

Oscillators	Parameters	Conditions		MIN.	TYP.	MAX.	Unit
High-speed on-chip oscillator clock frequency ^{Notes 1, 2}	f _{IH}			1		32	MHz
High-speed on-chip oscillator clock frequency accuracy		-20 to +85°C	1.8 V ≤ V _{DD} ≤ 5.5 V	-1.0		+1.0	%
			1.6 V ≤ V _{DD} < 1.8 V	-5.0		+5.0	%
		-40 to -20°C	1.8 V ≤ V _{DD} ≤ 5.5 V	-1.5		+1.5	%
			1.6 V ≤ V _{DD} < 1.8 V	-5.5		+5.5	%
Low-speed on-chip oscillator clock frequency	f _{IL}				15		kHz
Low-speed on-chip oscillator clock frequency accuracy				-15		+15	%

Notes 1. High-speed on-chip oscillator frequency is selected by bits 0 to 3 of option byte (000C2H/010C2H) and bits 0 to 2 of HOCODIV register.

2. This indicates the oscillator characteristics only. Refer to AC Characteristics for instruction execution time.

29.3 DC Characteristics

29.3.1 Pin characteristics

(T_A = -40 to +85°C, 1.6 V ≤ EV_{DD0} = EV_{DD1} ≤ V_{DD} ≤ 5.5 V, V_{SS} = EV_{SS0} = EV_{SS1} = 0 V) (1/5)

Items	Symbol	Conditions	MIN.	TYP.	MAX.	Unit		
Output current, high ^{Note 1}	I _{OH1}	Per pin for P00 to P07, P10 to P17, P30 to P37, P40 to P47, P50 to P57, P64 to P67, P70 to P77, P80 to P87, P90 to P97, P100 to P106, P110 to P117, P120, P125 to P127, P130, P140 to P147	1.6 V ≤ EV _{DD0} ≤ 5.5 V			-10.0 Note 2	mA	
		Total of P00 to P04, P07, P32 to P37, P40 to P47, P102 to P106, P120, P125 to P127, P130, P140 to P145 (When duty ≤ 70% ^{Note 3})	4.0 V ≤ EV _{DD0} ≤ 5.5 V			-55.0	mA	
			2.7 V ≤ EV _{DD0} < 4.0 V			-10.0	mA	
			1.8 V ≤ EV _{DD0} < 2.7 V			-5.0	mA	
			1.6 V ≤ EV _{DD0} < 1.8 V			-2.5	mA	
		Total of P05, P06, P10 to P17, P30, P31, P50 to P57, P64 to P67, P70 to P77, P80 to P87, P90 to P97, P100, P101, P110 to P117, P146, P147 (When duty ≤ 70% ^{Note 3})	4.0 V ≤ EV _{DD0} ≤ 5.5 V			-80.0	mA	
			2.7 V ≤ EV _{DD0} < 4.0 V			-19.0	mA	
			1.8 V ≤ EV _{DD0} < 2.7 V			-10.0	mA	
		Total of all pins (When duty ≤ 70% ^{Note 3})	1.6 V ≤ EV _{DD0} ≤ 5.5 V			-135.0 Note 4	mA	
		I _{OH2}	Per pin for P20 to P27, P150 to P156	1.6 V ≤ V _{DD} ≤ 5.5 V			-0.1 ^{Note 2}	mA
			Total of all pins (When duty ≤ 70% ^{Note 3})	1.6 V ≤ V _{DD} ≤ 5.5 V			-1.5	mA

Notes 1. Value of current at which the device operation is guaranteed even if the current flows from the EV_{DD0}, EV_{DD1}, V_{DD} pins to an output pin.

2. However, do not exceed the total current value.

3. Specification under conditions where the duty factor ≤ 70%.

The output current value that has changed to the duty factor > 70% the duty ratio can be calculated with the following expression (when changing the duty factor from 70% to n%).

- Total output current of pins = (I_{OH} × 0.7)/(n × 0.01)

<Example> Where n = 80% and I_{OH} = -10.0 mA

$$\text{Total output current of pins} = (-10.0 \times 0.7)/(80 \times 0.01) \cong -8.7 \text{ mA}$$

However, the current that is allowed to flow into one pin does not vary depending on the duty factor. A current higher than the absolute maximum rating must not flow into one pin.

4. The applied current for the products for industrial application (R5F100xxDxx, R5F101xxDxx, R5F100xxGxx) is -100 mA.

Caution P00, P02 to P04, P10 to P15, P17, P43 to P45, P50, P52 to P55, P71, P74, P80 to P82, P96, and P142 to P144 do not output high level in N-ch open-drain mode.

Remark Unless specified otherwise, the characteristics of alternate-function pins are the same as those of the port pins.

(T_A = -40 to +85°C, 1.6 V ≤ EV_{DD0} = EV_{DD1} ≤ V_{DD} ≤ 5.5 V, V_{SS} = EV_{SS0} = EV_{SS1} = 0 V) (2/5)

Items	Symbol	Conditions	MIN.	TYP.	MAX.	Unit	
Output current, I _{OL} ^{Note 1}	I _{OL1}	Per pin for P00 to P07, P10 to P17, P30 to P37, P40 to P47, P50 to P57, P64 to P67, P70 to P77, P80 to P87, P90 to P97, P100 to P106, P110 to P117, P120, P125 to P127, P130, P140 to P147			20.0 ^{Note 2}	mA	
		Per pin for P60 to P63			15.0 ^{Note 2}	mA	
		Total of P00 to P04, P07, P32 to P37, P40 to P47, P102 to P106, P120, P125 to P127, P130, P140 to P145 (When duty ≤ 70% ^{Note 3})	4.0 V ≤ EV _{DD0} ≤ 5.5 V			70.0	mA
			2.7 V ≤ EV _{DD0} < 4.0 V			15.0	mA
			1.8 V ≤ EV _{DD0} < 2.7 V			9.0	mA
			1.6 V ≤ EV _{DD0} < 1.8 V			4.5	mA
		Total of P05, P06, P10 to P17, P30, P31, P50 to P57, P60 to P67, P70 to P77, P80 to P87, P90 to P97, P100, P101, P110 to P117, P146, P147 (When duty ≤ 70% ^{Note 3})	4.0 V ≤ EV _{DD0} ≤ 5.5 V			80.0	mA
			2.7 V ≤ EV _{DD0} < 4.0 V			35.0	mA
			1.8 V ≤ EV _{DD0} < 2.7 V			20.0	mA
			1.6 V ≤ EV _{DD0} < 1.8 V			10.0	mA
Total of all pins (When duty ≤ 70% ^{Note 3})				150.0	mA		
I _{OL2}	Per pin for P20 to P27, P150 to P156				0.4 ^{Note 2}	mA	
	Total of all pins (When duty ≤ 70% ^{Note 3})	1.6 V ≤ V _{DD} ≤ 5.5 V			5.0	mA	

- Notes**
- Value of current at which the device operation is guaranteed even if the current flows from an output pin to the EV_{SS0}, EV_{SS1} and V_{SS} pin.
 - However, do not exceed the total current value.
 - Specification under conditions where the duty factor ≤ 70%.

The output current value that has changed to the duty factor > 70% the duty ratio can be calculated with the following expression (when changing the duty factor from 70% to n%).

- Total output current of pins = (I_{OL} × 0.7)/(n × 0.01)

<Example> Where n = 80% and I_{OL} = 10.0 mA

$$\text{Total output current of pins} = (10.0 \times 0.7)/(80 \times 0.01) \cong 8.7 \text{ mA}$$

However, the current that is allowed to flow into one pin does not vary depending on the duty factor. A current higher than the absolute maximum rating must not flow into one pin.

Remark Unless specified otherwise, the characteristics of alternate-function pins are the same as those of the port pins.

(T_A = -40 to +85°C, 1.6 V ≤ EV_{DD0} = EV_{DD1} ≤ V_{DD} ≤ 5.5 V, V_{SS} = EV_{SS0} = EV_{SS1} = 0 V) (3/5)

Items	Symbol	Conditions	MIN.	TYP.	MAX.	Unit	
Input voltage, high	V _{IH1}	P00 to P07, P10 to P17, P30 to P37, P40 to P47, P50 to P57, P64 to P67, P70 to P77, P80 to P87, P90 to P97, P100 to P106, P110 to P117, P120, P125 to P127, P140 to P147	Normal input buffer	0.8EV _{DD0}		EV _{DD0}	V
	V _{IH2}	P01, P03, P04, P10, P11, P13 to P17, P43, P44, P53 to P55, P80, P81, P142, P143	TTL input buffer 4.0 V ≤ EV _{DD0} ≤ 5.5 V	2.2		EV _{DD0}	V
			TTL input buffer 3.3 V ≤ EV _{DD0} < 4.0 V	2.0		EV _{DD0}	V
			TTL input buffer 1.6 V ≤ EV _{DD0} < 3.3 V	1.5		EV _{DD0}	V
	V _{IH3}	P20 to P27, P150 to P156		0.7V _{DD}		V _{DD}	V
	V _{IH4}	P60 to P63		0.7EV _{DD0}		6.0	V
V _{IH5}	P121 to P124, P137, EXCLK, EXCLKS, RESET		0.8V _{DD}		V _{DD}	V	
Input voltage, low	V _{IL1}	P00 to P07, P10 to P17, P30 to P37, P40 to P47, P50 to P57, P64 to P67, P70 to P77, P80 to P87, P90 to P97, P100 to P106, P110 to P117, P120, P125 to P127, P140 to P147	Normal input buffer	0		0.2EV _{DD0}	V
	V _{IL2}	P01, P03, P04, P10, P11, P13 to P17, P43, P44, P53 to P55, P80, P81, P142, P143	TTL input buffer 4.0 V ≤ EV _{DD0} ≤ 5.5 V	0		0.8	V
			TTL input buffer 3.3 V ≤ EV _{DD0} < 4.0 V	0		0.5	V
			TTL input buffer 1.6 V ≤ EV _{DD0} < 3.3 V	0		0.32	V
	V _{IL3}	P20 to P27, P150 to P156		0		0.3V _{DD}	V
	V _{IL4}	P60 to P63		0		0.3EV _{DD0}	V
	V _{IL5}	P121 to P124, P137, EXCLK, EXCLKS, RESET		0		0.2V _{DD}	V

Caution The maximum value of V_{IH} of pins P00, P02 to P04, P10 to P15, P17, P43 to P45, P50, P52 to P55, P71, P74, P80 to P82, P96, and P142 to P144 is EV_{DD0}, even in the N-ch open-drain mode.

Remark Unless specified otherwise, the characteristics of alternate-function pins are the same as those of the port pins.

($T_A = -40$ to $+85^\circ\text{C}$, $1.6\text{ V} \leq EV_{DD0} = EV_{DD1} \leq V_{DD} \leq 5.5\text{ V}$, $V_{SS} = EV_{SS0} = EV_{SS1} = 0\text{ V}$) (4/5)

Items	Symbol	Conditions	MIN.	TYP.	MAX.	Unit	
Output voltage, high	V_{OH1}	P00 to P07, P10 to P17, P30 to P37, P40 to P47, P50 to P57, P64 to P67, P70 to P77, P80 to P87, P90 to P97, P100 to P106, P110 to P117, P120, P125 to P127, P130, P140 to P147	$4.0\text{ V} \leq EV_{DD0} \leq 5.5\text{ V}$, $I_{OH1} = -10.0\text{ mA}$	$EV_{DD0} - 1.5$		V	
			$4.0\text{ V} \leq EV_{DD0} \leq 5.5\text{ V}$, $I_{OH1} = -3.0\text{ mA}$	$EV_{DD0} - 0.7$		V	
			$2.7\text{ V} \leq EV_{DD0} \leq 5.5\text{ V}$, $I_{OH1} = -2.0\text{ mA}$	$EV_{DD0} - 0.6$		V	
			$1.8\text{ V} \leq EV_{DD0} \leq 5.5\text{ V}$, $I_{OH1} = -1.5\text{ mA}$	$EV_{DD0} - 0.5$		V	
			$1.6\text{ V} \leq EV_{DD0} < 5.5\text{ V}$, $I_{OH1} = -1.0\text{ mA}$	$EV_{DD0} - 0.5$		V	
	V_{OH2}	P20 to P27, P150 to P156	$1.6\text{ V} \leq V_{DD} \leq 5.5\text{ V}$, $I_{OH2} = -100\text{ }\mu\text{A}$	$V_{DD} - 0.5$		V	
Output voltage, low	V_{OL1}	P00 to P07, P10 to P17, P30 to P37, P40 to P47, P50 to P57, P64 to P67, P70 to P77, P80 to P87, P90 to P97, P100 to P106, P110 to P117, P120, P125 to P127, P130, P140 to P147	$4.0\text{ V} \leq EV_{DD0} \leq 5.5\text{ V}$, $I_{OL1} = 20\text{ mA}$		1.3	V	
			$4.0\text{ V} \leq EV_{DD0} \leq 5.5\text{ V}$, $I_{OL1} = 8.5\text{ mA}$		0.7	V	
			$2.7\text{ V} \leq EV_{DD0} \leq 5.5\text{ V}$, $I_{OL1} = 3.0\text{ mA}$		0.6	V	
			$2.7\text{ V} \leq EV_{DD0} \leq 5.5\text{ V}$, $I_{OL1} = 1.5\text{ mA}$		0.4	V	
			$1.8\text{ V} \leq EV_{DD0} \leq 5.5\text{ V}$, $I_{OL1} = 0.6\text{ mA}$		0.4	V	
			$1.6\text{ V} \leq EV_{DD0} < 5.5\text{ V}$, $I_{OL1} = 0.3\text{ mA}$		0.4	V	
		V_{OL2}	P20 to P27, P150 to P156	$1.6\text{ V} \leq V_{DD} \leq 5.5\text{ V}$, $I_{OL2} = 400\text{ }\mu\text{A}$		0.4	V
	V_{OL3}	P60 to P63	$4.0\text{ V} \leq EV_{DD0} \leq 5.5\text{ V}$, $I_{OL3} = 15.0\text{ mA}$		2.0	V	
			$4.0\text{ V} \leq EV_{DD0} \leq 5.5\text{ V}$, $I_{OL3} = 5.0\text{ mA}$		0.4	V	
			$2.7\text{ V} \leq EV_{DD0} \leq 5.5\text{ V}$, $I_{OL3} = 3.0\text{ mA}$		0.4	V	
			$1.8\text{ V} \leq EV_{DD0} \leq 5.5\text{ V}$, $I_{OL3} = 2.0\text{ mA}$		0.4	V	
$1.6\text{ V} \leq EV_{DD0} < 5.5\text{ V}$, $I_{OL3} = 1.0\text{ mA}$				0.4	V		

Caution P00, P02 to P04, P10 to P15, P17, P43 to P45, P50, P52 to P55, P71, P74, P80 to P82, P96, and P142 to P144 do not output high level in N-ch open-drain mode.

Remark Unless specified otherwise, the characteristics of alternate-function pins are the same as those of the port pins.

($T_A = -40$ to $+85^\circ\text{C}$, $1.6\text{ V} \leq EV_{DD0} = EV_{DD1} \leq V_{DD} \leq 5.5\text{ V}$, $V_{SS} = EV_{SS0} = EV_{SS1} = 0\text{ V}$) (5/5)

Items	Symbol	Conditions	MIN.	TYP.	MAX.	Unit		
Input leakage current, high	I_{LH1}	P00 to P07, P10 to P17, P30 to P37, P40 to P47, P50 to P57, P60 to P67, P70 to P77, P80 to P87, P90 to P97, P100 to P106, P110 to P117, P120, P125 to P127, P140 to P147	$V_i = EV_{DD0}$		1	μA		
	I_{LH2}	P20 to P27, P137, P150 to P156, $\overline{\text{RESET}}$	$V_i = V_{DD}$		1	μA		
	I_{LH3}	P121 to P124 (X1, X2, XT1, XT2, EXCLK, EXCLKS)	$V_i = V_{DD}$	In input port or external clock input	1	μA		
				In resonator connection	10	μA		
Input leakage current, low	I_{LIL1}	P00 to P07, P10 to P17, P30 to P37, P40 to P47, P50 to P57, P60 to P67, P70 to P77, P80 to P87, P90 to P97, P100 to P106, P110 to P117, P120, P125 to P127, P140 to P147	$V_i = EV_{SS0}$		-1	μA		
	I_{LIL2}	P20 to P27, P137, P150 to P156, $\overline{\text{RESET}}$	$V_i = V_{SS}$		-1	μA		
	I_{LIL3}	P121 to P124 (X1, X2, XT1, XT2, EXCLK, EXCLKS)	$V_i = V_{SS}$	In input port or external clock input	-1	μA		
				In resonator connection	-10	μA		
On-chip pll-up resistance	R_U	P00 to P07, P10 to P17, P30 to P37, P40 to P47, P50 to P57, P64 to P67, P70 to P77, P80 to P87, P90 to P97, P100 to P106, P110 to P117, P120, P125 to P127, P140 to P147	$V_i = EV_{SS0}$, In input port		10	20	100	$\text{k}\Omega$

Remark Unless specified otherwise, the characteristics of alternate-function pins are the same as those of the port pins.

29.3.2 Supply current characteristics

(1) Flash ROM: 16 to 64 KB of 20- to 64-pin products

(T_A = -40 to +85°C, 1.6 V ≤ EV_{DD0} ≤ V_{DD} ≤ 5.5 V, V_{SS} = EV_{SS0} = 0 V) (1/2)

Parameter	Symbol	Conditions				MIN.	TYP.	MAX.	Unit	
Supply current ^{Note 1}	I _{DD1}	Operating mode	HS (high-speed main) mode ^{Note 5}	f _{IH} = 32 MHz ^{Note 3}	Basic operation	V _{DD} = 5.0 V		2.1		mA
						V _{DD} = 3.0 V		2.1		mA
					Normal operation	V _{DD} = 5.0 V		4.6	7.0	mA
				V _{DD} = 3.0 V			4.6	7.0	mA	
				f _{IH} = 24 MHz ^{Note 3}	Normal operation	V _{DD} = 5.0 V		3.7	5.5	mA
						V _{DD} = 3.0 V		3.7	5.5	mA
			f _{IH} = 16 MHz ^{Note 3}	Normal operation	V _{DD} = 5.0 V		2.7	4.0	mA	
					V _{DD} = 3.0 V		2.7	4.0	mA	
			LS (low-speed main) mode ^{Note 5}	f _{IH} = 8 MHz ^{Note 3}	Normal operation	V _{DD} = 3.0 V		1.2	1.8	mA
						V _{DD} = 2.0 V		1.2	1.8	mA
			LV (low-voltage main) mode ^{Note 5}	f _{IH} = 4 MHz ^{Note 3}	Normal operation	V _{DD} = 3.0 V		1.2	1.7	mA
						V _{DD} = 2.0 V		1.2	1.7	mA
		HS (high-speed main) mode ^{Note 5}	f _{MX} = 20 MHz ^{Note 2} , V _{DD} = 5.0 V	Normal operation	Square wave input		3.0	4.6	mA	
					Resonator connection		3.2	4.8	mA	
				Normal operation	Square wave input		3.0	4.6	mA	
					Resonator connection		3.2	4.8	mA	
			f _{MX} = 10 MHz ^{Note 2} , V _{DD} = 5.0 V	Normal operation	Square wave input		1.9	2.7	mA	
					Resonator connection		1.9	2.7	mA	
			f _{MX} = 10 MHz ^{Note 2} , V _{DD} = 3.0 V	Normal operation	Square wave input		1.9	2.7	mA	
					Resonator connection		1.9	2.7	mA	
		LS (low-speed main) mode ^{Note 5}	f _{MX} = 8 MHz ^{Note 2} , V _{DD} = 3.0 V	Normal operation	Square wave input		1.1	1.7	mA	
					Resonator connection		1.1	1.7	mA	
			f _{MX} = 8 MHz ^{Note 2} , V _{DD} = 2.0 V	Normal operation	Square wave input		1.1	1.7	mA	
					Resonator connection		1.1	1.7	mA	
Subsystem clock operation	f _{SUB} = 32.768 kHz ^{Note 4} T _A = -40°C	Normal operation	Square wave input		4.1	4.9	μA			
			Resonator connection		4.2	5.0	μA			
	f _{SUB} = 32.768 kHz ^{Note 4} T _A = +25°C	Normal operation	Square wave input		4.1	4.9	μA			
			Resonator connection		4.2	5.0	μA			
	f _{SUB} = 32.768 kHz ^{Note 4} T _A = +50°C	Normal operation	Square wave input		4.2	5.5	μA			
			Resonator connection		4.3	5.6	μA			
	f _{SUB} = 32.768 kHz ^{Note 4} T _A = +70°C	Normal operation	Square wave input		4.3	6.3	μA			
			Resonator connection		4.4	6.4	μA			
f _{SUB} = 32.768 kHz ^{Note 4} T _A = +85°C	Normal operation	Square wave input		4.6	7.7	μA				
		Resonator connection		4.7	7.8	μA				

(Notes and Remarks are listed on the next page.)

Notes 1. Total current flowing into V_{DD} and EV_{DD0} , including the input leakage current flowing when the level of the input pin is fixed to V_{DD} , EV_{DD0} or V_{SS} , EV_{SS0} . The following points apply in the HS (high-speed main), LS (low-speed main), and LV (low-voltage main) modes.

- The currents in the “TYP.” column do not include the operating currents of the peripheral modules.
- The currents in the “MAX.” column include the operating currents of the peripheral modules, except for those flowing into the A/D converter, LVD circuit, I/O port, and on-chip pull-up/pull-down resistors, and those flowing while the data flash memory is being rewritten.

In the subsystem clock operation, the currents in both the “TYP.” and “MAX.” columns do not include the operating currents of the peripheral modules. However, in HALT mode, including the current flowing into the RTC.

2. When high-speed on-chip oscillator and subsystem clock are stopped.
3. When high-speed system clock and subsystem clock are stopped.
4. When high-speed on-chip oscillator and high-speed system clock are stopped. When AMPHS1 = 1 (Ultra-low power consumption oscillation).
5. Relationship between operation voltage width, operation frequency of CPU and operation mode is as below.
 - HS (high-speed main) mode: $2.7\text{ V} \leq V_{DD} \leq 5.5\text{ V}@1\text{ MHz to }32\text{ MHz}$
 $2.4\text{ V} \leq V_{DD} \leq 5.5\text{ V}@1\text{ MHz to }16\text{ MHz}$
 - LS (low-speed main) mode: $1.8\text{ V} \leq V_{DD} \leq 5.5\text{ V}@1\text{ MHz to }8\text{ MHz}$
 - LV (low-voltage main) mode: $1.6\text{ V} \leq V_{DD} \leq 5.5\text{ V}@1\text{ MHz to }4\text{ MHz}$

Remarks 1. f_{MX} : High-speed system clock frequency (X1 clock oscillation frequency or external main system clock frequency)

2. f_{IH} : High-speed on-chip oscillator clock frequency
3. f_{SUB} : Subsystem clock frequency (XT1 clock oscillation frequency)
4. Except subsystem clock operation, temperature condition of the TYP. value is $T_A = 25^\circ\text{C}$

(1) Flash ROM: 16 to 64 KB of 20- to 64-pin products

(T_A = -40 to +85°C, 1.6 V ≤ EV_{DD0} ≤ V_{DD} ≤ 5.5 V, V_{SS} = EV_{SS0} = 0 V) (2/2)

Parameter	Symbol	Conditions		MIN.	TYP.	MAX.	Unit		
Supply current Note 1	I _{DD2} Note 2	HALT mode	HS (high-speed main) mode Note 6	f _{IH} = 32 MHz Note 4	V _{DD} = 5.0 V		0.54	1.63	mA
					V _{DD} = 3.0 V		0.54	1.63	mA
				f _{IH} = 24 MHz Note 4	V _{DD} = 5.0 V		0.44	1.28	mA
					V _{DD} = 3.0 V		0.44	1.28	mA
				f _{IH} = 16 MHz Note 4	V _{DD} = 5.0 V		0.40	1.00	mA
					V _{DD} = 3.0 V		0.40	1.00	mA
			LS (low-speed main) mode Note 6	f _{IH} = 8 MHz Note 4	V _{DD} = 3.0 V		260	530	μA
					V _{DD} = 2.0 V		260	530	μA
			LV (low-voltage main) mode Note 6	f _{IH} = 4 MHz Note 4	V _{DD} = 3.0 V		420	640	μA
					V _{DD} = 2.0 V		420	640	μA
			HS (high-speed main) mode Note 6	f _{MX} = 20 MHz Note 3, V _{DD} = 5.0 V	Square wave input		0.28	1.00	mA
					Resonator connection		0.45	1.17	mA
				f _{MX} = 20 MHz Note 3, V _{DD} = 3.0 V	Square wave input		0.28	1.00	mA
					Resonator connection		0.45	1.17	mA
				f _{MX} = 10 MHz Note 3, V _{DD} = 5.0 V	Square wave input		0.19	0.60	mA
					Resonator connection		0.26	0.67	mA
				f _{MX} = 10 MHz Note 3, V _{DD} = 3.0 V	Square wave input		0.19	0.60	mA
					Resonator connection		0.26	0.67	mA
			LS (low-speed main) mode Note 6	f _{MX} = 8 MHz Note 3, V _{DD} = 3.0 V	Square wave input		95	330	μA
					Resonator connection		145	380	μA
				f _{MX} = 8 MHz Note 3, V _{DD} = 2.0 V	Square wave input		95	330	μA
					Resonator connection		145	380	μA
			Subsystem clock operation	f _{SUB} = 32.768 kHz Note 5 T _A = -40°C	Square wave input		0.25	0.57	μA
					Resonator connection		0.44	0.76	μA
				f _{SUB} = 32.768 kHz Note 5 T _A = +25°C	Square wave input		0.30	0.57	μA
					Resonator connection		0.49	0.76	μA
				f _{SUB} = 32.768 kHz Note 5 T _A = +50°C	Square wave input		0.37	1.17	μA
Resonator connection		0.56			1.36	μA			
f _{SUB} = 32.768 kHz Note 5 T _A = +70°C	Square wave input			0.53	1.97	μA			
	Resonator connection			0.72	2.16	μA			
f _{SUB} = 32.768 kHz Note 5 T _A = +85°C	Square wave input		0.82	3.37	μA				
	Resonator connection		1.01	3.56	μA				
I _{DD3}	STOP mode Note 7	T _A = -40°C			0.18	0.50	μA		
		T _A = +25°C			0.23	0.50	μA		
		T _A = +50°C			0.30	1.10	μA		
		T _A = +70°C			0.46	1.90	μA		
		T _A = +85°C			0.75	3.30	μA		

(Notes and Remarks are listed on the next page.)

Notes 1. Total current flowing into V_{DD} and EV_{DD0} , including the input leakage current flowing when the level of the input pin is fixed to V_{DD} , EV_{DD0} or V_{SS} , EV_{SS0} . The following points apply in the HS (high-speed main), LS (low-speed main), and LV (low-voltage main) modes.

- The currents in the “TYP.” column do not include the operating currents of the peripheral modules.
- The currents in the “MAX.” column include the operating currents of the peripheral modules, except for those flowing into the A/D converter, LVD circuit, I/O port, and on-chip pull-up/pull-down resistors, and those flowing while the data flash memory is being rewritten.

In the subsystem clock operation, the currents in both the “TYP.” and “MAX.” columns do not include the operating currents of the peripheral modules. However, in HALT mode, including the current flowing into the RTC.

In the STOP mode, the currents in both the “TYP.” and “MAX.” columns do not include the operating currents of the peripheral modules.

2. During HALT instruction execution by flash memory.
3. When high-speed on-chip oscillator and subsystem clock are stopped.
4. When high-speed system clock and subsystem clock are stopped.
5. When high-speed on-chip oscillator and high-speed system clock are stopped. When $RTCLPC = 1$ and setting ultra-low current consumption ($AMPHS1 = 1$).
6. Relationship between operation voltage width, operation frequency of CPU and operation mode is as below.
 - HS (high-speed main) mode: $2.7\text{ V} \leq V_{DD} \leq 5.5\text{ V}@1\text{ MHz to }32\text{ MHz}$
 $2.4\text{ V} \leq V_{DD} \leq 5.5\text{ V}@1\text{ MHz to }16\text{ MHz}$
 - LS (low-speed main) mode: $1.8\text{ V} \leq V_{DD} \leq 5.5\text{ V}@1\text{ MHz to }8\text{ MHz}$
 - LV (low-voltage main) mode: $1.6\text{ V} \leq V_{DD} \leq 5.5\text{ V}@1\text{ MHz to }4\text{ MHz}$
7. Regarding the value for current to operate the subsystem clock in STOP mode, refer to that in HALT mode.

Remarks 1. f_{MX} : High-speed system clock frequency (X1 clock oscillation frequency or external main system clock frequency)

2. f_{IH} : High-speed on-chip oscillator clock frequency
3. f_{SUB} : Subsystem clock frequency (XT1 clock oscillation frequency)
4. Except subsystem clock operation and STOP mode, temperature condition of the TYP. value is $T_A = 25^\circ\text{C}$

(2) Flash ROM: 96 to 256 KB of 30- to 100-pin products

(T_A = -40 to +85°C, 1.6 V ≤ EV_{DD0} = EV_{DD1} ≤ V_{DD} ≤ 5.5 V, V_{SS} = EV_{SS0} = EV_{SS1} = 0 V) (1/2)

Parameter	Symbol	Conditions				MIN.	TYP.	MAX.	Unit	
Supply current Note 1	I _{DD1}	Operating mode	HS (high-speed main) mode Note 5	f _{IH} = 32 MHz Note 3	Basic operation	V _{DD} = 5.0 V		2.3		mA
						V _{DD} = 3.0 V		2.3		mA
					Normal operation	V _{DD} = 5.0 V		5.2	8.5	mA
						V _{DD} = 3.0 V		5.2	8.5	mA
					Normal operation	V _{DD} = 5.0 V		4.1	6.6	mA
						V _{DD} = 3.0 V		4.1	6.6	mA
				f _{IH} = 24 MHz Note 3	Normal operation	V _{DD} = 5.0 V		3.0	4.7	mA
						V _{DD} = 3.0 V		3.0	4.7	mA
					Normal operation	V _{DD} = 5.0 V		1.3	2.1	mA
						V _{DD} = 2.0 V		1.3	2.1	mA
					Normal operation	V _{DD} = 3.0 V		1.3	1.8	mA
						V _{DD} = 2.0 V		1.3	1.8	mA
			LS (low-speed main) mode Note 5	f _{IH} = 4 MHz Note 3	Normal operation	Square wave input		3.4	5.5	mA
						Resonator connection		3.6	5.7	mA
					Normal operation	Square wave input		3.4	5.5	mA
						Resonator connection		3.6	5.7	mA
					Normal operation	Square wave input		2.1	3.2	mA
						Resonator connection		2.1	3.2	mA
				f _{IH} = 16 MHz Note 3	Normal operation	Square wave input		2.1	3.2	mA
						Resonator connection		2.1	3.2	mA
					Normal operation	Square wave input		1.2	2.0	mA
						Resonator connection		1.2	2.0	mA
					Normal operation	Square wave input		1.2	2.0	mA
						Resonator connection		1.2	2.0	mA
			Subsystem clock operation	f _{SUB} = 32.768 kHz Note 4 T _A = -40°C	Normal operation	Square wave input		4.8	5.9	μA
						Resonator connection		4.9	6.0	μA
					Normal operation	Square wave input		4.9	5.9	μA
						Resonator connection		5.0	6.0	μA
Normal operation	Square wave input				5.0	7.6	μA			
	Resonator connection				5.1	7.7	μA			
f _{SUB} = 32.768 kHz Note 4 T _A = +25°C	Normal operation	Square wave input			5.2	9.3	μA			
		Resonator connection			5.3	9.4	μA			
	Normal operation	Square wave input			5.7	13.3	μA			
		Resonator connection			5.8	13.4	μA			
	Normal operation	Square wave input			5.0	7.6	μA			
		Resonator connection			5.1	7.7	μA			

(Notes and Remarks are listed on the next page.)

Notes 1. Total current flowing into V_{DD} , EV_{DD0} , and EV_{DD1} , including the input leakage current flowing when the level of the input pin is fixed to V_{DD} , EV_{DD0} , and EV_{DD1} , or V_{SS} , EV_{SS0} , and EV_{SS1} . The following points apply in the HS (high-speed main), LS (low-speed main), and LV (low-voltage main) modes.

- The currents in the “TYP.” column do not include the operating currents of the peripheral modules.
- The currents in the “MAX.” column include the operating currents of the peripheral modules, except for those flowing into the A/D converter, LVD circuit, I/O port, and on-chip pull-up/pull-down resistors, and those flowing while the data flash memory is being rewritten.

In the subsystem clock operation, the currents in both the “TYP.” and “MAX.” columns do not include the operating currents of the peripheral modules. However, in HALT mode, including the current flowing into the RTC.

2. When high-speed on-chip oscillator and subsystem clock are stopped.
3. When high-speed system clock and subsystem clock are stopped.
4. When high-speed on-chip oscillator and high-speed system clock are stopped. When $AMPHS1 = 1$ (Ultra-low power consumption oscillation).
5. Relationship between operation voltage width, operation frequency of CPU and operation mode is as below.
 - HS (high-speed main) mode: $2.7\text{ V} \leq V_{DD} \leq 5.5\text{ V}@1\text{ MHz to }32\text{ MHz}$
 $2.4\text{ V} \leq V_{DD} \leq 5.5\text{ V}@1\text{ MHz to }16\text{ MHz}$
 - LS (low-speed main) mode: $1.8\text{ V} \leq V_{DD} \leq 5.5\text{ V}@1\text{ MHz to }8\text{ MHz}$
 - LV (low-voltage main) mode: $1.6\text{ V} \leq V_{DD} \leq 5.5\text{ V}@1\text{ MHz to }4\text{ MHz}$

Remarks 1. f_{MX} : High-speed system clock frequency (X1 clock oscillation frequency or external main system clock frequency)

2. f_{IH} : High-speed on-chip oscillator clock frequency
3. f_{SUB} : Subsystem clock frequency (XT1 clock oscillation frequency)
4. Except subsystem clock operation, temperature condition of the TYP. value is $T_A = 25^\circ\text{C}$

(2) Flash ROM: 96 to 256 KB of 30- to 100-pin products**(T_A = -40 to +85°C, 1.6 V ≤ EV_{DD0} = EV_{DD1} ≤ V_{DD} ≤ 5.5 V, V_{SS} = EV_{SS0} = EV_{SS1} = 0 V) (2/2)**

Parameter	Symbol	Conditions		MIN.	TYP.	MAX.	Unit		
Supply current Note 1	I _{DD2} Note 2	HALT mode	HS (high-speed main) mode Note 6	f _{IH} = 32 MHz Note 4	V _{DD} = 5.0 V		0.62	1.86	mA
					V _{DD} = 3.0 V		0.62	1.86	mA
				f _{IH} = 24 MHz Note 4	V _{DD} = 5.0 V		0.50	1.45	mA
					V _{DD} = 3.0 V		0.50	1.45	mA
				f _{IH} = 16 MHz Note 4	V _{DD} = 5.0 V		0.44	1.11	mA
					V _{DD} = 3.0 V		0.44	1.11	mA
			LS (low-speed main) mode Note 6	f _{IH} = 8 MHz Note 4	V _{DD} = 3.0 V		290	620	μA
				V _{DD} = 2.0 V		290	620	μA	
			LV (low-voltage main) mode Note 6	f _{IH} = 4 MHz Note 4	V _{DD} = 3.0 V		440	680	μA
					V _{DD} = 2.0 V		440	680	μA
			HS (high-speed main) mode Note 6	f _{MX} = 20 MHz Note 3, V _{DD} = 5.0 V	Square wave input		0.31	1.08	mA
					Resonator connection		0.48	1.28	mA
					Square wave input		0.31	1.08	mA
					Resonator connection		0.48	1.28	mA
				f _{MX} = 10 MHz Note 3, V _{DD} = 5.0 V	Square wave input		0.21	0.63	mA
					Resonator connection		0.28	0.71	mA
				f _{MX} = 10 MHz Note 3, V _{DD} = 3.0 V	Square wave input		0.21	0.63	mA
					Resonator connection		0.28	0.71	mA
			LS (low-speed main) mode Note 6	f _{MX} = 8 MHz Note 3, V _{DD} = 3.0 V	Square wave input		110	360	μA
					Resonator connection		160	420	μA
		f _{MX} = 8 MHz Note 3, V _{DD} = 2.0 V		Square wave input		110	360	μA	
				Resonator connection		160	420	μA	
		Subsystem clock operation	f _{SUB} = 32.768 kHz Note 5 T _A = -40°C	Square wave input		0.28	0.61	μA	
				Resonator connection		0.47	0.80	μA	
			f _{SUB} = 32.768 kHz Note 5 T _A = +25°C	Square wave input		0.34	0.61	μA	
				Resonator connection		0.53	0.80	μA	
			f _{SUB} = 32.768 kHz Note 5 T _A = +50°C	Square wave input		0.41	2.30	μA	
				Resonator connection		0.60	2.49	μA	
			f _{SUB} = 32.768 kHz Note 5 T _A = +70°C	Square wave input		0.64	4.03	μA	
				Resonator connection		0.83	4.22	μA	
f _{SUB} = 32.768 kHz Note 5 T _A = +85°C	Square wave input		1.09	8.04	μA				
Resonator connection		1.28	8.23	μA					
I _{DD3}	STOP mode Note 7	T _A = -40°C			0.19	0.52	μA		
		T _A = +25°C			0.25	0.52	μA		
		T _A = +50°C			0.32	2.21	μA		
		T _A = +70°C			0.55	3.94	μA		
		T _A = +85°C			1.00	7.95	μA		

(Notes and Remarks are listed on the next page.)

- Notes**
- Total current flowing into V_{DD} , EV_{DD0} , and EV_{DD1} , including the input leakage current flowing when the level of the input pin is fixed to V_{DD} , EV_{DD0} , and EV_{DD1} , or V_{SS} , EV_{SS0} , and EV_{SS1} . The following points apply in the HS (high-speed main), LS (low-speed main), and LV (low-voltage main) modes.
 - The currents in the "TYP." column do not include the operating currents of the peripheral modules.
 - The currents in the "MAX." column include the operating currents of the peripheral modules, except for those flowing into the A/D converter, LVD circuit, I/O port, and on-chip pull-up/pull-down resistors, and those flowing while the data flash memory is being rewritten.

In the subsystem clock operation, the currents in both the "TYP." and "MAX." columns do not include the operating currents of the peripheral modules. However, in HALT mode, including the current flowing into the RTC.

In the STOP mode, the currents in both the "TYP." and "MAX." columns do not include the operating currents of the peripheral modules.
 - During HALT instruction execution by flash memory.
 - When high-speed on-chip oscillator and subsystem clock are stopped.
 - When high-speed system clock and subsystem clock are stopped.
 - When high-speed on-chip oscillator and high-speed system clock are stopped. When $RTCLPC = 1$ and setting ultra-low current consumption ($AMPHS1 = 1$).
 - Relationship between operation voltage width, operation frequency of CPU and operation mode is as below.
 - HS (high-speed main) mode: $2.7\text{ V} \leq V_{DD} \leq 5.5\text{ V}@1\text{ MHz to }32\text{ MHz}$
 $2.4\text{ V} \leq V_{DD} \leq 5.5\text{ V}@1\text{ MHz to }16\text{ MHz}$
 - LS (low-speed main) mode: $1.8\text{ V} \leq V_{DD} \leq 5.5\text{ V}@1\text{ MHz to }8\text{ MHz}$
 - LV (low-voltage main) mode: $1.6\text{ V} \leq V_{DD} \leq 5.5\text{ V}@1\text{ MHz to }4\text{ MHz}$
 - Regarding the value for current to operate the subsystem clock in STOP mode, refer to that in HALT mode.

- Remarks**
- f_{MX} : High-speed system clock frequency (X1 clock oscillation frequency or external main system clock frequency)
 - f_{IH} : High-speed on-chip oscillator clock frequency
 - f_{SUB} : Subsystem clock frequency (XT1 clock oscillation frequency)
 - Except subsystem clock operation and STOP mode, temperature condition of the TYP. value is $T_A = 25^\circ\text{C}$

(3) 128-pin products, and flash ROM: 384 to 512 KB of 44- to 100-pin products

(T_A = -40 to +85°C, 1.6 V ≤ EV_{DD0} = EV_{DD1} ≤ V_{DD} ≤ 5.5 V, V_{SS} = EV_{SS0} = EV_{SS1} = 0 V) (1/2)

Parameter	Symbol	Conditions				MIN.	TYP.	MAX.	Unit
Supply current ^{Note 1}	I _{DD1}	Operating mode	HS (high-speed main) mode ^{Note 5}	f _{IH} = 32 MHz ^{Note 3}	Basic operation	V _{DD} = 5.0 V	2.6		mA
						V _{DD} = 3.0 V	2.6		mA
					Normal operation	V _{DD} = 5.0 V	6.1	9.5	mA
				V _{DD} = 3.0 V		6.1	9.5	mA	
				f _{IH} = 24 MHz ^{Note 3}	Normal operation	V _{DD} = 5.0 V	4.8	7.4	mA
						V _{DD} = 3.0 V	4.8	7.4	mA
			f _{IH} = 16 MHz ^{Note 3}	Normal operation	V _{DD} = 5.0 V	3.5	5.3	mA	
					V _{DD} = 3.0 V	3.5	5.3	mA	
			LS (low-speed main) mode ^{Note 5}	f _{IH} = 8 MHz ^{Note 3}	Normal operation	V _{DD} = 3.0 V	1.5	2.3	mA
						V _{DD} = 2.0 V	1.5	2.3	mA
			LV (low-voltage main) mode ^{Note 5}	f _{IH} = 4 MHz ^{Note 3}	Normal operation	V _{DD} = 3.0 V	1.5	2.0	mA
						V _{DD} = 2.0 V	1.5	2.0	mA
		HS (high-speed main) mode ^{Note 5}	f _{MX} = 20 MHz ^{Note 2} , V _{DD} = 5.0 V	Normal operation	Square wave input	3.9	6.1	mA	
					Resonator connection	4.1	6.3	mA	
				Normal operation	Square wave input	3.9	6.1	mA	
					Resonator connection	4.1	6.3	mA	
			f _{MX} = 10 MHz ^{Note 2} , V _{DD} = 3.0 V	Normal operation	Square wave input	2.5	3.7	mA	
					Resonator connection	2.5	3.7	mA	
				Normal operation	Square wave input	2.5	3.7	mA	
					Resonator connection	2.5	3.7	mA	
		LS (low-speed main) mode ^{Note 5}	f _{MX} = 8 MHz ^{Note 2} , V _{DD} = 3.0 V	Normal operation	Square wave input	1.4	2.2	mA	
					Resonator connection	1.4	2.2	mA	
			f _{MX} = 8 MHz ^{Note 2} , V _{DD} = 2.0 V	Normal operation	Square wave input	1.4	2.2	mA	
					Resonator connection	1.4	2.2	mA	
Subsystem clock operation	f _{SUB} = 32.768 kHz ^{Note 4} T _A = -40°C	Normal operation	Square wave input	5.4	6.5	μA			
			Resonator connection	5.5	6.6	μA			
		Normal operation	Square wave input	5.5	6.5	μA			
			Resonator connection	5.6	6.6	μA			
		f _{SUB} = 32.768 kHz ^{Note 4} T _A = +25°C	Normal operation	Square wave input	5.6	9.4	μA		
				Resonator connection	5.7	9.5	μA		
	f _{SUB} = 32.768 kHz ^{Note 4} T _A = +50°C	Normal operation	Square wave input	5.9	12.0	μA			
			Resonator connection	6.0	12.1	μA			
		f _{SUB} = 32.768 kHz ^{Note 4} T _A = +70°C	Normal operation	Square wave input	6.6	16.3	μA		
				Resonator connection	6.7	16.4	μA		
		f _{SUB} = 32.768 kHz ^{Note 4} T _A = +85°C	Normal operation	Square wave input	6.6	16.3	μA		
				Resonator connection	6.7	16.4	μA		

(Notes and Remarks are listed on the next page.)

Notes 1. Total current flowing into V_{DD}, EV_{DD0}, and EV_{DD1}, including the input leakage current flowing when the level of the input pin is fixed to V_{DD}, EV_{DD0}, and EV_{DD1}, or V_{SS}, EV_{SS0}, and EV_{SS1}. The following points apply in the HS (high-speed main), LS (low-speed main), and LV (low-voltage main) modes.

- The currents in the “TYP.” column do not include the operating currents of the peripheral modules.
- The currents in the “MAX.” column include the operating currents of the peripheral modules, except for those flowing into the A/D converter, LVD circuit, I/O port, and on-chip pull-up/pull-down resistors, and those flowing while the data flash memory is being rewritten.

In the subsystem clock operation, the currents in both the “TYP.” and “MAX.” columns do not include the operating currents of the peripheral modules. However, in HALT mode, including the current flowing into the RTC.

2. When high-speed on-chip oscillator and subsystem clock are stopped.
3. When high-speed system clock and subsystem clock are stopped.
4. When high-speed on-chip oscillator and high-speed system clock are stopped. When AMPHS1 = 1 (Ultra-low power consumption oscillation).
5. Relationship between operation voltage width, operation frequency of CPU and operation mode is as below.
 - HS (high-speed main) mode: $2.7\text{ V} \leq V_{DD} \leq 5.5\text{ V}@1\text{ MHz to }32\text{ MHz}$
 $2.4\text{ V} \leq V_{DD} \leq 5.5\text{ V}@1\text{ MHz to }16\text{ MHz}$
 - LS (low-speed main) mode: $1.8\text{ V} \leq V_{DD} \leq 5.5\text{ V}@1\text{ MHz to }8\text{ MHz}$
 - LV (low-voltage main) mode: $1.6\text{ V} \leq V_{DD} \leq 5.5\text{ V}@1\text{ MHz to }4\text{ MHz}$

Remarks 1. f_{MX}: High-speed system clock frequency (X1 clock oscillation frequency or external main system clock frequency)

2. f_{IH}: High-speed on-chip oscillator clock frequency
3. f_{SUB}: Subsystem clock frequency (XT1 clock oscillation frequency)
4. Except subsystem clock operation, temperature condition of the TYP. value is T_A = 25°C

(3) 128-pin products, and flash ROM: 384 to 512 KB of 44- to 100-pin products**(T_A = -40 to +85°C, 1.6 V ≤ EV_{DD0} = EV_{DD1} ≤ V_{DD} ≤ 5.5 V, V_{SS} = EV_{SS0} = EV_{SS1} = 0 V) (2/2)**

Parameter	Symbol	Conditions			MIN.	TYP.	MAX.	Unit		
Supply current Note 1	I _{DD2} Note 2	HALT mode	HS (high-speed main) mode Note 6	f _{IH} = 32 MHz Note 4	V _{DD} = 5.0 V		0.62	1.89	mA	
					V _{DD} = 3.0 V		0.62	1.89	mA	
				f _{IH} = 24 MHz Note 4	V _{DD} = 5.0 V		0.50	1.48	mA	
					V _{DD} = 3.0 V		0.50	1.48	mA	
				f _{IH} = 16 MHz Note 4	V _{DD} = 5.0 V		0.44	1.12	mA	
					V _{DD} = 3.0 V		0.44	1.12	mA	
			LS (low-speed main) mode Note 6	f _{IH} = 8 MHz Note 4	V _{DD} = 3.0 V		290	620	μA	
					V _{DD} = 2.0 V		290	620	μA	
			LV (low-voltage main) mode Note 6	f _{IH} = 4 MHz Note 4	V _{DD} = 3.0 V		460	700	μA	
					V _{DD} = 2.0 V		460	700	μA	
			HS (high-speed main) mode Note 6	f _{MX} = 20 MHz Note 3, V _{DD} = 5.0 V	Square wave input		0.31	1.14	mA	
					Resonator connection		0.48	1.34	mA	
					f _{MX} = 20 MHz Note 3, V _{DD} = 3.0 V	Square wave input		0.31	1.14	mA
						Resonator connection		0.48	1.34	mA
					f _{MX} = 10 MHz Note 3, V _{DD} = 5.0 V	Square wave input		0.21	0.68	mA
						Resonator connection		0.28	0.76	mA
			LS (low-speed main) mode Note 6	f _{MX} = 8 MHz Note 3, V _{DD} = 3.0 V	Square wave input		110	390	μA	
					Resonator connection		160	450	μA	
		f _{MX} = 8 MHz Note 3, V _{DD} = 2.0 V		Square wave input		110	390	μA		
				Resonator connection		160	450	μA		
		Subsystem clock operation	f _{SUB} = 32.768 kHz Note 5 T _A = -40°C	Square wave input		0.31	0.66	μA		
				Resonator connection		0.50	0.85	μA		
			f _{SUB} = 32.768 kHz Note 5 T _A = +25°C	Square wave input		0.38	0.66	μA		
				Resonator connection		0.57	0.85	μA		
			f _{SUB} = 32.768 kHz Note 5 T _A = +50°C	Square wave input		0.47	3.49	μA		
				Resonator connection		0.66	3.68	μA		
			f _{SUB} = 32.768 kHz Note 5 T _A = +70°C	Square wave input		0.80	6.10	μA		
				Resonator connection		0.99	6.29	μA		
			f _{SUB} = 32.768 kHz Note 5 T _A = +85°C	Square wave input		1.52	10.46	μA		
				Resonator connection		1.71	10.65	μA		
I _{DD3}	STOP mode Note 7	T _A = -40°C				0.19	0.54	μA		
		T _A = +25°C				0.26	0.54	μA		
		T _A = +50°C				0.35	3.37	μA		
		T _A = +70°C				0.68	5.98	μA		
		T _A = +85°C				1.40	10.34	μA		

(Notes and Remarks are listed on the next page.)

Notes 1. Total current flowing into V_{DD} , EV_{DD0} , and EV_{DD1} , including the input leakage current flowing when the level of the input pin is fixed to V_{DD} , EV_{DD0} , and EV_{DD1} , or V_{SS} , EV_{SS0} , and EV_{SS1} . The following points apply in the HS (high-speed main), LS (low-speed main), and LV (low-voltage main) modes.

- The currents in the “TYP.” column do not include the operating currents of the peripheral modules.
- The currents in the “MAX.” column include the operating currents of the peripheral modules, except for those flowing into the A/D converter, LVD circuit, I/O port, and on-chip pull-up/pull-down resistors, and those flowing while the data flash memory is being rewritten.

In the subsystem clock operation, the currents in both the “TYP.” and “MAX.” columns do not include the operating currents of the peripheral modules. However, in HALT mode, including the current flowing into the RTC.

In the STOP mode, the currents in both the “TYP.” and “MAX.” columns do not include the operating currents of the peripheral modules.

2. During HALT instruction execution by flash memory.
3. When high-speed on-chip oscillator and subsystem clock are stopped.
4. When high-speed system clock and subsystem clock are stopped.
5. When high-speed on-chip oscillator and high-speed system clock are stopped. When $RTCLPC = 1$ and setting ultra-low current consumption ($AMPHS1 = 1$).
6. Relationship between operation voltage width, operation frequency of CPU and operation mode is as below.
 - HS (high-speed main) mode: $2.7\text{ V} \leq V_{DD} \leq 5.5\text{ V}@1\text{ MHz to }32\text{ MHz}$
 $2.4\text{ V} \leq V_{DD} \leq 5.5\text{ V}@1\text{ MHz to }16\text{ MHz}$
 - LS (low-speed main) mode: $1.8\text{ V} \leq V_{DD} \leq 5.5\text{ V}@1\text{ MHz to }8\text{ MHz}$
 - LV (low-voltage main) mode: $1.6\text{ V} \leq V_{DD} \leq 5.5\text{ V}@1\text{ MHz to }4\text{ MHz}$
7. Regarding the value for current to operate the subsystem clock in STOP mode, refer to that in HALT mode.

Remarks 1. f_{MX} : High-speed system clock frequency (X1 clock oscillation frequency or external main system clock frequency)

2. f_{IH} : High-speed on-chip oscillator clock frequency
3. f_{SUB} : Subsystem clock frequency (XT1 clock oscillation frequency)
4. Except subsystem clock operation and STOP mode, temperature condition of the TYP. value is $T_A = 25^\circ\text{C}$

(4) Peripheral Functions (Common to all products)**(T_A = -40 to +85°C, 1.6 V ≤ EV_{DD0} = EV_{DD1} ≤ V_{DD} ≤ 5.5 V, V_{SS} = EV_{SS0} = EV_{SS1} = 0 V)**

Parameter	Symbol	Conditions		MIN.	TYP.	MAX.	Unit
Low-speed on-chip oscillator operating current	I _{FIL} ^{Note 1}				0.20		μA
RTC operating current	I _{RTC} ^{Notes 1, 2, 3}				0.02		μA
12-bit interval timer operating current	I _{IT} ^{Notes 1, 2, 4}				0.02		μA
Watchdog timer operating current	I _{WDT} ^{Notes 1, 2, 5}	f _{IL} = 15 kHz			0.22		μA
A/D converter operating current	I _{ADC} ^{Notes 1, 6}	When conversion at maximum speed	Normal mode, AV _{REFP} = V _{DD} = 5.0 V		1.3	1.7	mA
			Low voltage mode, AV _{REFP} = V _{DD} = 3.0 V		0.5	0.7	mA
A/D converter reference voltage current	I _{ADREF} ^{Note 1}				75.0		μA
Temperature sensor operating current	I _{TMPS} ^{Note 1}				75.0		μA
LVD operating current	I _{LVI} ^{Notes 1, 7}				0.08		μA
Self-programming operating current	I _{FSP} ^{Notes 1, 9}				2.50	12.20	mA
BGO operating current	I _{BGO} ^{Notes 1, 8}				2.50	12.20	mA
SNOOZE operating current	I _{SNOZ} ^{Note 1}	ADC operation	The mode is performed ^{Note 10}		0.50	0.60	mA
			The A/D conversion operations are performed, Low voltage mode, AV _{REFP} = V _{DD} = 3.0 V		1.20	1.44	mA
		Simplified SPI (CSI)/UART operation				0.70	0.84

Notes 1. Current flowing to V_{DD}.

2. When high speed on-chip oscillator and high-speed system clock are stopped.
3. Current flowing only to the real-time clock (RTC) (excluding the operating current of the low-speed on-chip oscillator and the XT1 oscillator). The supply current of the RL78 microcontrollers is the sum of the values of either I_{DD1} or I_{DD2}, and I_{RTC}, when the real-time clock operates in operation mode or HALT mode. When the low-speed on-chip oscillator is selected, I_{FIL} should be added. I_{DD2} subsystem clock operation includes the operational current of the real-time clock.
4. Current flowing only to the 12-bit interval timer (excluding the operating current of the low-speed on-chip oscillator and the XT1 oscillator). The supply current of the RL78 microcontrollers is the sum of the values of either I_{DD1} or I_{DD2}, and I_{IT}, when the 12-bit interval timer operates in operation mode or HALT mode. When the low-speed on-chip oscillator is selected, I_{FIL} should be added.
5. Current flowing only to the watchdog timer (including the operating current of the low-speed on-chip oscillator). The supply current of the RL78 microcontrollers is the sum of I_{DD1}, I_{DD2} or I_{DD3} and I_{WDT} when the watchdog timer is in operation.
6. Current flowing only to the A/D converter. The supply current of the RL78 microcontrollers is the sum of I_{DD1} or I_{DD2} and I_{ADC} when the A/D converter operates in an operation mode or the HALT mode.

- Notes**
7. Current flowing only to the LVD circuit. The supply current of the RL78 microcontrollers is the sum of I_{DD1} , I_{DD2} or I_{DD3} and I_{LVD} when the LVD circuit is in operation.
 8. Current flowing only during data flash rewrite.
 9. Current flowing only during self programming.
 10. For shift time to the SNOOZE mode, see **18.3.3 SNOOZE mode**.

- Remarks**
1. f_{IL} : Low-speed on-chip oscillator clock frequency
 2. f_{SUB} : Subsystem clock frequency (XT1 clock oscillation frequency)
 3. f_{CLK} : CPU/peripheral hardware clock frequency
 4. Temperature condition of the TYP. value is $T_A = 25^\circ\text{C}$

29.4 AC Characteristics

(T_A = -40 to +85°C, 1.6 V ≤ EV_{DD0} = EV_{DD1} ≤ V_{DD} ≤ 5.5 V, V_{SS} = EV_{SS0} = EV_{SS1} = 0 V)

Items	Symbol	Conditions		MIN.	TYP.	MAX.	Unit	
Instruction cycle (minimum instruction execution time)	T _{CY}	Main system clock (f _{MAIN}) operation	HS (high-speed main) mode	2.7 V ≤ V _{DD} ≤ 5.5 V	0.03125	1	μs	
				2.4 V ≤ V _{DD} < 2.7 V	0.0625	1	μs	
			LS (low-speed main) mode	1.8 V ≤ V _{DD} ≤ 5.5 V	0.125	1	μs	
				1.6 V ≤ V _{DD} < 1.8 V	0.25	1	μs	
		Subsystem clock (f _{SUB}) operation		1.8 V ≤ V _{DD} ≤ 5.5 V	28.5	30.5	31.3	μs
		In the self programming mode	HS (high-speed main) mode	2.7 V ≤ V _{DD} ≤ 5.5 V	0.03125	1	μs	
				2.4 V ≤ V _{DD} < 2.7 V	0.0625	1	μs	
			LS (low-speed main) mode	1.8 V ≤ V _{DD} ≤ 5.5 V	0.125	1	μs	
1.6 V ≤ V _{DD} < 1.8 V	0.25			1	μs			
External system clock frequency	f _{EX}	2.7 V ≤ V _{DD} ≤ 5.5 V		1.0		20.0	MHz	
		2.4 V ≤ V _{DD} < 2.7 V		1.0		16.0	MHz	
		1.8 V ≤ V _{DD} < 2.4 V		1.0		8.0	MHz	
		1.6 V ≤ V _{DD} < 1.8 V		1.0		4.0	MHz	
	f _{EXS}			32		35	kHz	
External system clock input high-level width, low-level width	t _{EXH} , t _{EXL}	2.7 V ≤ V _{DD} ≤ 5.5 V		24			ns	
		2.4 V ≤ V _{DD} < 2.7 V		30			ns	
		1.8 V ≤ V _{DD} < 2.4 V		60			ns	
		1.6 V ≤ V _{DD} < 1.8 V		120			ns	
	t _{EXHS} , t _{EXLS}			13.7			μs	
TI00 to TI07, TI10 to TI17 input high-level width, low-level width	t _{TIH} , t _{TIL}			1/f _{MCK} +10			ns ^{Note}	
TO00 to TO07, TO10 to TO17 output frequency	f _{TO}	HS (high-speed main) mode	4.0 V ≤ EV _{DD0} ≤ 5.5 V			16	MHz	
			2.7 V ≤ EV _{DD0} < 4.0 V			8	MHz	
			1.8 V ≤ EV _{DD0} < 2.7 V			4	MHz	
			1.6 V ≤ EV _{DD0} < 1.8 V			2	MHz	
		LS (low-speed main) mode	1.8 V ≤ EV _{DD0} ≤ 5.5 V			4	MHz	
			1.6 V ≤ EV _{DD0} < 1.8 V			2	MHz	
		LV (low-voltage main) mode	1.6 V ≤ EV _{DD0} ≤ 5.5 V			2	MHz	
PCLBUZ0, PCLBUZ1 output frequency	f _{PCL}	HS (high-speed main) mode	4.0 V ≤ EV _{DD0} ≤ 5.5 V			16	MHz	
			2.7 V ≤ EV _{DD0} < 4.0 V			8	MHz	
			1.8 V ≤ EV _{DD0} < 2.7 V			4	MHz	
			1.6 V ≤ EV _{DD0} < 1.8 V			2	MHz	
		LS (low-speed main) mode	1.8 V ≤ EV _{DD0} ≤ 5.5 V			4	MHz	
			1.6 V ≤ EV _{DD0} < 1.8 V			2	MHz	
		LV (low-voltage main) mode	1.8 V ≤ EV _{DD0} ≤ 5.5 V			4	MHz	
		1.6 V ≤ EV _{DD0} < 1.8 V			2	MHz		
Interrupt input high-level width, low-level width	t _{INTH} , t _{INTL}	INTP0	1.6 V ≤ V _{DD} ≤ 5.5 V	1			μs	
		INTP1 to INTP11	1.6 V ≤ EV _{DD0} ≤ 5.5 V	1			μs	
Key interrupt input low-level width	t _{KR}	KR0 to KR7	1.8 V ≤ EV _{DD0} ≤ 5.5 V	250			ns	
			1.6 V ≤ EV _{DD0} < 1.8 V	1			μs	
RESET low-level width	t _{RSL}			10			μs	

(Note and Remark are listed on the next page.)

Note The following conditions are required for low voltage interface when E_{VDD0} < V_{DD}

1.8 V ≤ E_{VDD0} < 2.7 V : MIN. 125 ns

1.6 V ≤ E_{VDD0} < 1.8 V : MIN. 250 ns

Remark f_{MCK}: Timer array unit operation clock frequency

(Operation clock to be set by the CKS_{mn0}, CKS_{mn1} bits of timer mode register mn (TMR_{mn}).

m: Unit number (m = 0, 1), n: Channel number (n = 0 to 7))

Minimum Instruction Execution Time during Main System Clock Operation

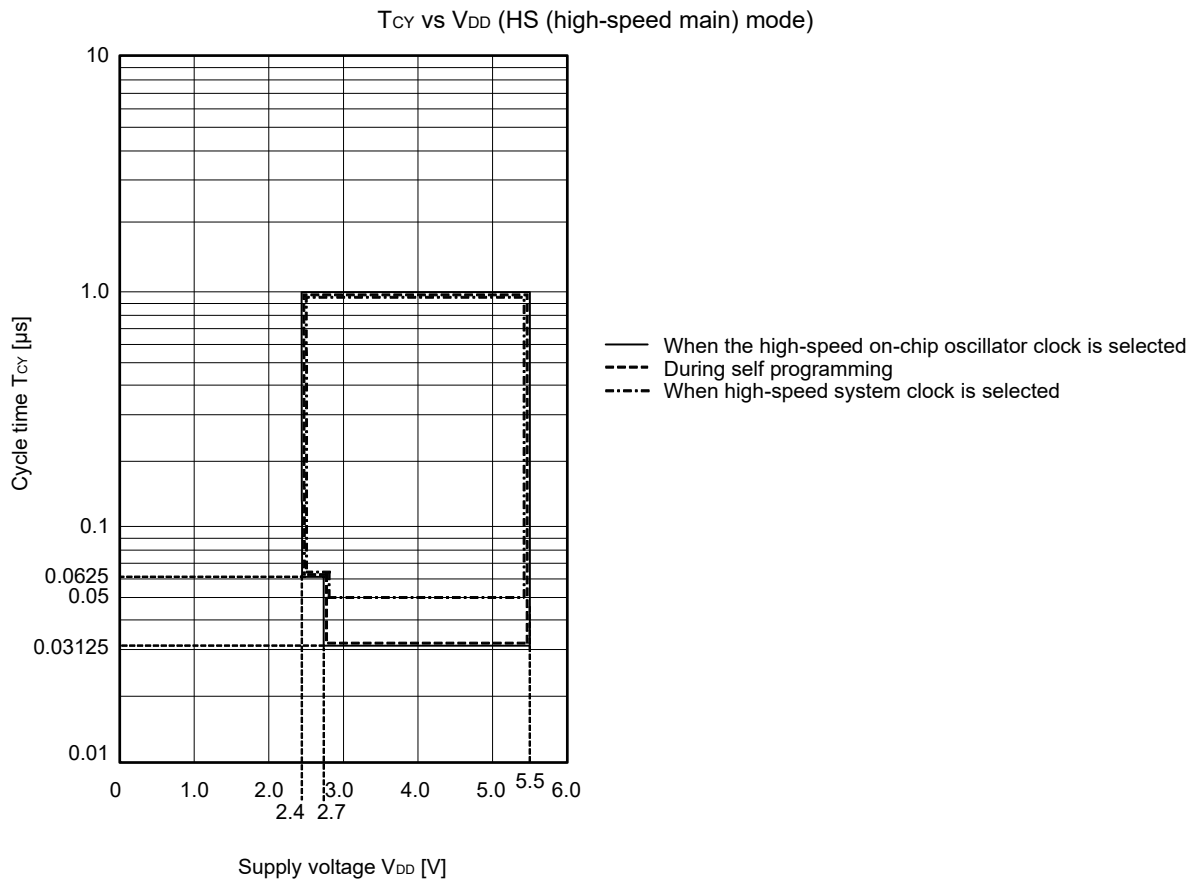

T_{CY} vs V_{DD} (LS (low-speed main) mode)

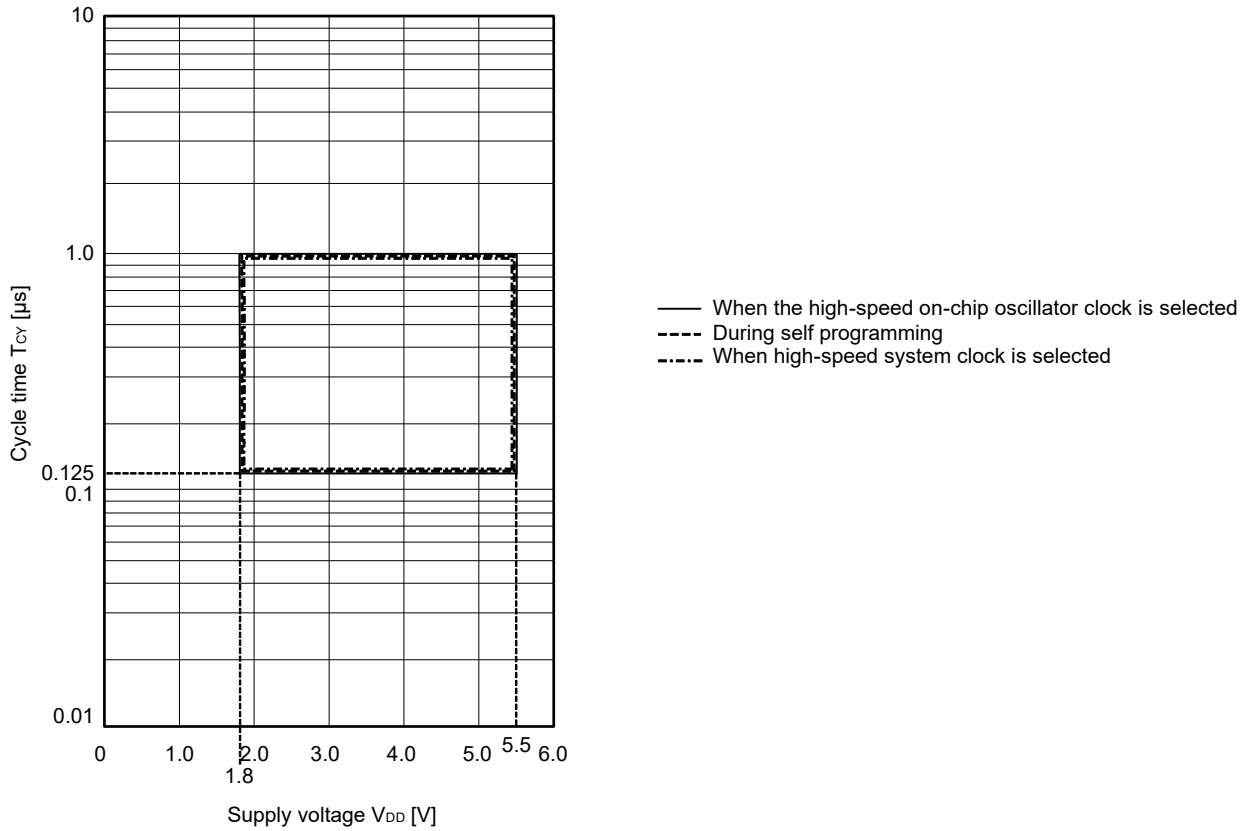

T_{CY} vs V_{DD} (LV (low-voltage main) mode)

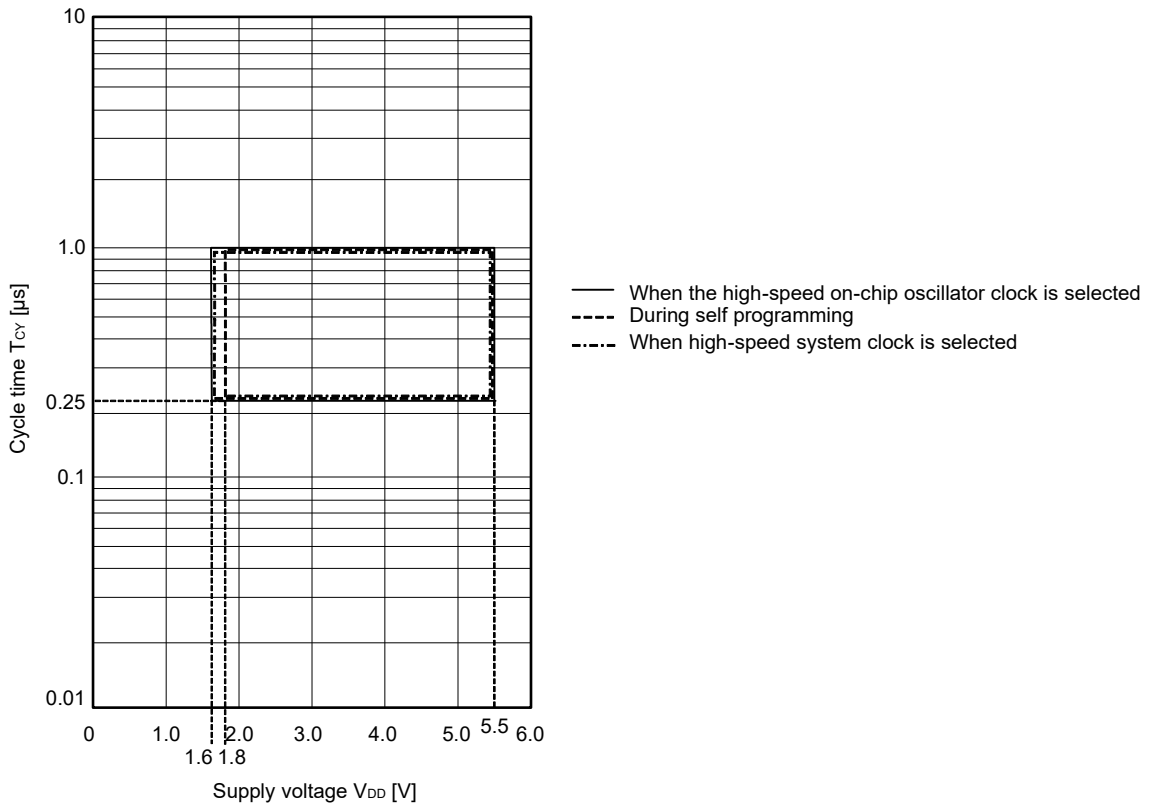

AC Timing Test Points

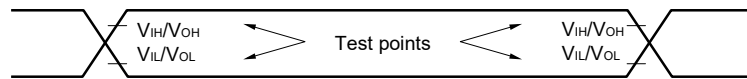

External System Clock Timing

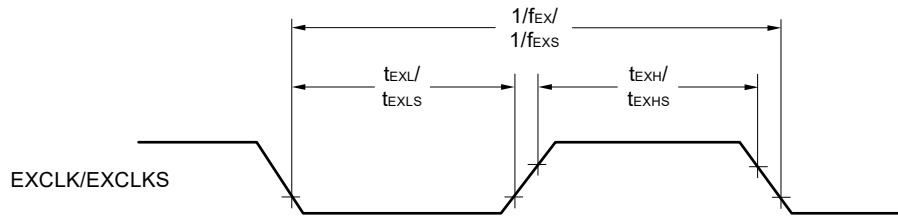

TI/TO Timing

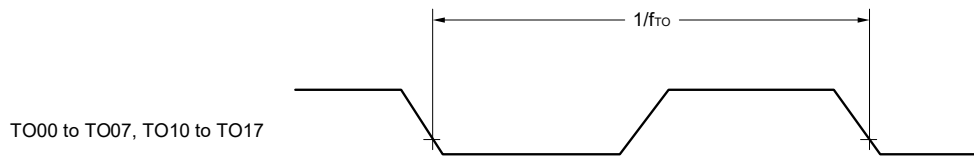
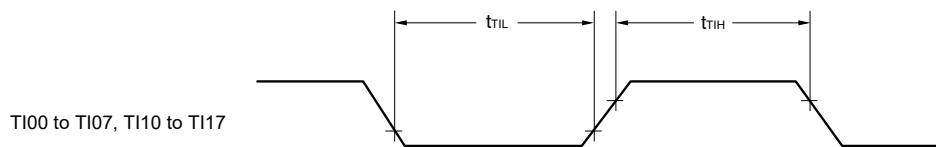

Interrupt Request Input Timing

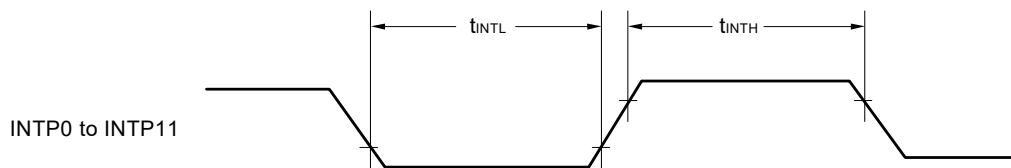

Key Interrupt Input Timing

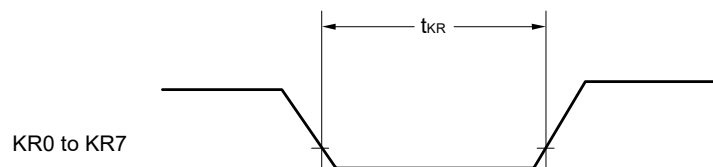

RESET Input Timing

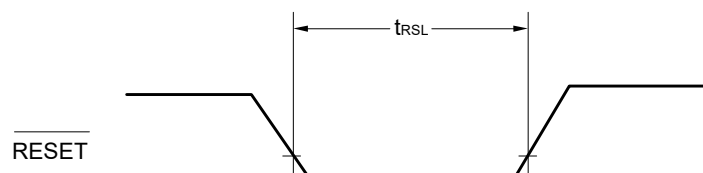

29.5 Peripheral Functions Characteristics

AC Timing Test Points

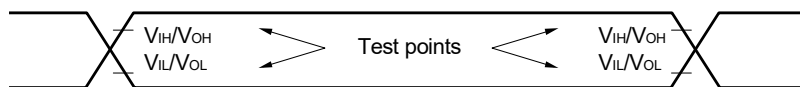

29.5.1 Serial array unit

(1) During communication at same potential (UART mode)

(T_A = -40 to +85°C, 1.6 V ≤ EV_{DD0} = EV_{DD1} ≤ V_{DD} ≤ 5.5 V, V_{SS} = EV_{SS0} = EV_{SS1} = 0 V)

Parameter	Symbol	Conditions	HS (high-speed main) Mode		LS (low-speed main) Mode		LV (low-voltage main) Mode		Unit
			MIN.	MAX.	MIN.	MAX.	MIN.	MAX.	
Transfer rate ^{Note 1}		2.4 V ≤ EV _{DD0} ≤ 5.5 V		f _{MCK} /6 ^{Note 2}		f _{MCK} /6		f _{MCK} /6	bps
		Theoretical value of the maximum transfer rate f _{MCK} = f _{CLK} ^{Note 3}		5.3		1.3		0.6	Mbps
		1.8 V ≤ EV _{DD0} ≤ 5.5 V		f _{MCK} /6 ^{Note 2}		f _{MCK} /6		f _{MCK} /6	bps
		Theoretical value of the maximum transfer rate f _{MCK} = f _{CLK} ^{Note 3}		5.3		1.3		0.6	Mbps
		1.7 V ≤ EV _{DD0} ≤ 5.5 V		f _{MCK} /6 ^{Note 2}		f _{MCK} /6 ^{Note 2}		f _{MCK} /6	bps
		Theoretical value of the maximum transfer rate f _{MCK} = f _{CLK} ^{Note 3}		5.3		1.3		0.6	Mbps
1.6 V ≤ EV _{DD0} ≤ 5.5 V		–		f _{MCK} /6 ^{Note 2}		f _{MCK} /6	bps		
	Theoretical value of the maximum transfer rate f _{MCK} = f _{CLK} ^{Note 3}		–		1.3		0.6	Mbps	

Notes 1. Transfer rate in the SNOOZE mode is 4800 bps only.

2. The following conditions are required for low voltage interface when EV_{DD0} < V_{DD}.

2.4 V ≤ EV_{DD0} < 2.7 V : MAX. 2.6 Mbps

1.8 V ≤ EV_{DD0} < 2.4 V : MAX. 1.3 Mbps

1.6 V ≤ EV_{DD0} < 1.8 V : MAX. 0.6 Mbps

3. The maximum operating frequencies of the CPU/peripheral hardware clock (f_{CLK}) are:

HS (high-speed main) mode: 32 MHz (2.7 V ≤ V_{DD} ≤ 5.5 V)

16 MHz (2.4 V ≤ V_{DD} ≤ 5.5 V)

LS (low-speed main) mode: 8 MHz (1.8 V ≤ V_{DD} ≤ 5.5 V)

LV (low-voltage main) mode: 4 MHz (1.6 V ≤ V_{DD} ≤ 5.5 V)

Caution Select the normal input buffer for the RxDq pin and the normal output mode for the TxDq pin by using port input mode register g (PIMg) and port output mode register g (POMg).

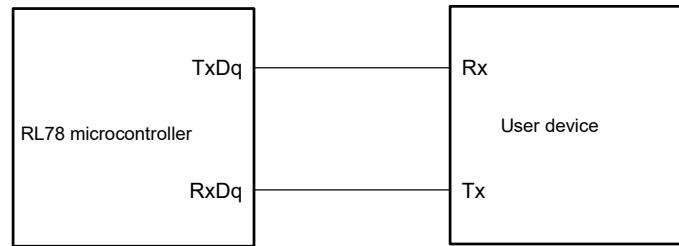
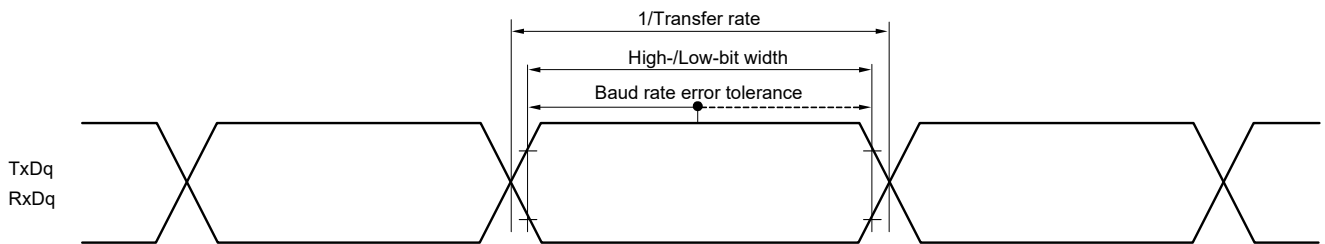
UART mode connection diagram (during communication at same potential)**UART mode bit width (during communication at same potential) (reference)**

- Remarks 1.** q: UART number (q = 0 to 3), g: PIM and POM number (g = 0, 1, 8, 14)
- 2.** f_{MCK} : Serial array unit operation clock frequency
 (Operation clock to be set by the CKSmn bit of serial mode register mn (SMRmn). m: Unit number, n: Channel number (mn = 00 to 03, 10 to 13))

(2) During communication at same potential (Simplified SPI (CSI) mode) (master mode, SCKp... internal clock output, corresponding CSI00 only)**(T_A = -40 to +85°C, 2.7 V ≤ EV_{DD0} = EV_{DD1} ≤ V_{DD} ≤ 5.5 V, V_{SS} = EV_{SS0} = EV_{SS1} = 0 V)**

Parameter	Symbol	Conditions	HS (high-speed main) Mode		LS (low-speed main) Mode		LV (low-voltage main) Mode		Unit
			MIN.	MAX.	MIN.	MAX.	MIN.	MAX.	
SCKp cycle time	t _{KCY1}	t _{KCY1} ≥ 2/f _{CLK} 4.0 V ≤ EV _{DD0} ≤ 5.5 V	62.5		250		500		ns
		2.7 V ≤ EV _{DD0} ≤ 5.5 V	83.3		250		500		ns
SCKp high-/low-level width	t _{KH1} , t _{KL1}	4.0 V ≤ EV _{DD0} ≤ 5.5 V	t _{KCY1} /2 – 7		t _{KCY1} /2 – 50		t _{KCY1} /2 – 50		ns
		2.7 V ≤ EV _{DD0} ≤ 5.5 V	t _{KCY1} /2 – 10		t _{KCY1} /2 – 50		t _{KCY1} /2 – 50		ns
Slp setup time (to SCKp↑) Note 1	t _{SIK1}	4.0 V ≤ EV _{DD0} ≤ 5.5 V	23		110		110		ns
		2.7 V ≤ EV _{DD0} ≤ 5.5 V	33		110		110		ns
Slp hold time (from SCKp↓) Note 2	t _{KS1}	2.7 V ≤ EV _{DD0} ≤ 5.5 V	10		10		10		ns
Delay time from SCKp↓ to SOp output Note 3	t _{KSO1}	C = 20 pF Note 4		10		10		10	ns

- Notes**
1. When DAP_{mn} = 0 and CKP_{mn} = 0, or DAP_{mn} = 1 and CKP_{mn} = 1. The Slp setup time becomes “to SCKp↓” when DAP_{mn} = 0 and CKP_{mn} = 1, or DAP_{mn} = 1 and CKP_{mn} = 0.
 2. When DAP_{mn} = 0 and CKP_{mn} = 0, or DAP_{mn} = 1 and CKP_{mn} = 1. The Slp hold time becomes “from SCKp↓” when DAP_{mn} = 0 and CKP_{mn} = 1, or DAP_{mn} = 1 and CKP_{mn} = 0.
 3. When DAP_{mn} = 0 and CKP_{mn} = 0, or DAP_{mn} = 1 and CKP_{mn} = 1. The delay time to SOp output becomes “from SCKp↑” when DAP_{mn} = 0 and CKP_{mn} = 1, or DAP_{mn} = 1 and CKP_{mn} = 0.
 4. C is the load capacitance of the SCKp and SOp output lines.

Caution Select the normal input buffer for the Slp pin and the normal output mode for the SOp pin and SCKp pin by using port input mode register g (PIMg) and port output mode register g (POMg).

- Remarks**
1. This value is valid only when CSI00's peripheral I/O redirect function is not used.
 2. p: CSI number (p = 00), m: Unit number (m = 0), n: Channel number (n = 0),
g: PIM and POM numbers (g = 1)
 3. f_{MCK}: Serial array unit operation clock frequency
(Operation clock to be set by the CKS_{mn} bit of serial mode register mn (SMR_{mn}). m: Unit number,
n: Channel number (mn = 00))

(3) During communication at same potential (Simplified SPI (CSI) mode) (master mode, SCKp... internal clock output)**(T_A = -40 to +85°C, 1.6 V ≤ EV_{DD0} = EV_{DD1} ≤ V_{DD} ≤ 5.5 V, V_{SS} = EV_{SS0} = EV_{SS1} = 0 V)**

Parameter	Symbol	Conditions	HS (high-speed main) Mode		LS (low-speed main) Mode		LV (low-voltage main) Mode		Unit
			MIN.	MAX.	MIN.	MAX.	MIN.	MAX.	
SCKp cycle time	t _{KCY1}	t _{KCY1} ≥ 4/f _{CLK}	2.7 V ≤ EV _{DD0} ≤ 5.5 V	125		500		1000	ns
			2.4 V ≤ EV _{DD0} ≤ 5.5 V	250		500		1000	ns
			1.8 V ≤ EV _{DD0} ≤ 5.5 V	500		500		1000	ns
			1.7 V ≤ EV _{DD0} ≤ 5.5 V	1000		1000		1000	ns
			1.6 V ≤ EV _{DD0} ≤ 5.5 V	–		1000		1000	ns
SCKp high-/low-level width	t _{KH1} , t _{KL1}	4.0 V ≤ EV _{DD0} ≤ 5.5 V	t _{KCY1} /2 – 12		t _{KCY1} /2 – 50		t _{KCY1} /2 – 50	ns	
		2.7 V ≤ EV _{DD0} ≤ 5.5 V	t _{KCY1} /2 – 18		t _{KCY1} /2 – 50		t _{KCY1} /2 – 50	ns	
		2.4 V ≤ EV _{DD0} ≤ 5.5 V	t _{KCY1} /2 – 38		t _{KCY1} /2 – 50		t _{KCY1} /2 – 50	ns	
		1.8 V ≤ EV _{DD0} ≤ 5.5 V	t _{KCY1} /2 – 50		t _{KCY1} /2 – 50		t _{KCY1} /2 – 50	ns	
		1.7 V ≤ EV _{DD0} ≤ 5.5 V	t _{KCY1} /2 – 100		t _{KCY1} /2 – 100		t _{KCY1} /2 – 100	ns	
		1.6 V ≤ EV _{DD0} ≤ 5.5 V	–		t _{KCY1} /2 – 100		t _{KCY1} /2 – 100	ns	
Slp setup time (to SCKp↑) Note 1	t _{SIK1}	4.0 V ≤ EV _{DD0} ≤ 5.5 V	44		110		110	ns	
		2.7 V ≤ EV _{DD0} ≤ 5.5 V	44		110		110	ns	
		2.4 V ≤ EV _{DD0} ≤ 5.5 V	75		110		110	ns	
		1.8 V ≤ EV _{DD0} ≤ 5.5 V	110		110		110	ns	
		1.7 V ≤ EV _{DD0} ≤ 5.5 V	220		220		220	ns	
		1.6 V ≤ EV _{DD0} ≤ 5.5 V	–		220		220	ns	
Slp hold time (from SCKp↑) Note 2	t _{SH1}	1.7 V ≤ EV _{DD0} ≤ 5.5 V	19		19		19	ns	
		1.6 V ≤ EV _{DD0} ≤ 5.5 V	–		19		19	ns	
Delay time from SCKp↓ to SOp output Note 3	t _{KSO1}	1.7 V ≤ EV _{DD0} ≤ 5.5 V C = 30 pF ^{Note 4}		25		25		25	ns
		1.6 V ≤ EV _{DD0} ≤ 5.5 V C = 30 pF ^{Note 4}		–		25		25	ns

- Notes**
1. When DAP_mn = 0 and CKP_mn = 0, or DAP_mn = 1 and CKP_mn = 1. The Slp setup time becomes “to SCKp↓” when DAP_mn = 0 and CKP_mn = 1, or DAP_mn = 1 and CKP_mn = 0.
 2. When DAP_mn = 0 and CKP_mn = 0, or DAP_mn = 1 and CKP_mn = 1. The Slp hold time becomes “from SCKp↓” when DAP_mn = 0 and CKP_mn = 1, or DAP_mn = 1 and CKP_mn = 0.
 3. When DAP_mn = 0 and CKP_mn = 0, or DAP_mn = 1 and CKP_mn = 1. The delay time to SOp output becomes “from SCKp↑” when DAP_mn = 0 and CKP_mn = 1, or DAP_mn = 1 and CKP_mn = 0.
 4. C is the load capacitance of the SCKp and SOp output lines.

Caution Select the normal input buffer for the Slp pin and the normal output mode for the SOp pin and SCKp pin by using port input mode register g (PIMg) and port output mode register g (POMg).

- Remarks 1.** p: CSI number (p = 00, 01, 10, 11, 20, 21, 30, 31), m: Unit number (m = 0, 1), n: Channel number (n = 0 to 3), g: PIM and POM numbers (g = 0, 1, 4, 5, 8, 14)
- 2.** f_{MCK}: Serial array unit operation clock frequency
(Operation clock to be set by the CKSmn bit of serial mode register mn (SMRmn). m: Unit number, n: Channel number (mn = 00 to 03, 10 to 13))

(4) During communication at same potential (Simplified SPI (CSI) mode) (slave mode, SCKp... external clock input) (1/2)

(T_A = -40 to +85°C, 1.6 V ≤ EV_{DD0} = EV_{DD1} ≤ V_{DD} ≤ 5.5 V, V_{SS} = EV_{SS0} = EV_{SS1} = 0 V)

Parameter	Symbol	Conditions		HS (high-speed main) Mode		LS (low-speed main) Mode		LV (low-voltage main) Mode		Unit	
				MIN.	MAX.	MIN.	MAX.	MIN.	MAX.		
SCKp cycle time Note 5	t _{KCY2}	4.0 V ≤ EV _{DD0} ≤ 5.5 V	20 MHz < f _{MCK}	8/f _{MCK}		–		–		ns	
			f _{MCK} ≤ 20 MHz	6/f _{MCK}		6/f _{MCK}		6/f _{MCK}		ns	
		2.7 V ≤ EV _{DD0} ≤ 5.5 V	16 MHz < f _{MCK}	8/f _{MCK}		–		–		ns	
			f _{MCK} ≤ 16 MHz	6/f _{MCK}		6/f _{MCK}		6/f _{MCK}		ns	
		2.4 V ≤ EV _{DD0} ≤ 5.5 V			6/f _{MCK} and 500		6/f _{MCK} and 500		6/f _{MCK} and 500		ns
		1.8 V ≤ EV _{DD0} ≤ 5.5 V			6/f _{MCK} and 750		6/f _{MCK} and 750		6/f _{MCK} and 750		ns
		1.7 V ≤ EV _{DD0} ≤ 5.5 V			6/f _{MCK} and 1500		6/f _{MCK} and 1500		6/f _{MCK} and 1500		ns
		1.6 V ≤ EV _{DD0} ≤ 5.5 V			–		6/f _{MCK} and 1500		6/f _{MCK} and 1500		ns
SCKp high-/low-level width	t _{KH2} , t _{KL2}	4.0 V ≤ EV _{DD0} ≤ 5.5 V		t _{KCY2} /2 – 7		t _{KCY2} /2 – 7		t _{KCY2} /2 – 7		ns	
		2.7 V ≤ EV _{DD0} ≤ 5.5 V		t _{KCY2} /2 – 8		t _{KCY2} /2 – 8		t _{KCY2} /2 – 8		ns	
		1.8 V ≤ EV _{DD0} ≤ 5.5 V		t _{KCY2} /2 – 18		t _{KCY2} /2 – 18		t _{KCY2} /2 – 18		ns	
		1.7 V ≤ EV _{DD0} ≤ 5.5 V		t _{KCY2} /2 – 66		t _{KCY2} /2 – 66		t _{KCY2} /2 – 66		ns	
		1.6 V ≤ EV _{DD0} ≤ 5.5 V		–		t _{KCY2} /2 – 66		t _{KCY2} /2 – 66		ns	

(Notes, Caution, and Remarks are listed on the next page.)

(4) During communication at same potential (Simplified SPI (CSI) mode) (slave mode, SCKp... external clock input) (2/2)**(T_A = -40 to +85°C, 1.6 V ≤ EV_{DD0} = EV_{DD1} ≤ V_{DD} ≤ 5.5 V, V_{SS} = EV_{SS0} = EV_{SS1} = 0 V)**

Parameter	Symbol	Conditions	HS (high-speed main) Mode		LS (low-speed main) Mode		LV (low-voltage main) Mode		Unit	
			MIN.	MAX.	MIN.	MAX.	MIN.	MAX.		
Slp setup time (to SCKp↑) ^{Note 1}	t _{SIK2}	2.7 V ≤ EV _{DD0} ≤ 5.5 V	1/f _{MCK} +20		1/f _{MCK} +30		1/f _{MCK} +30		ns	
		1.8 V ≤ EV _{DD0} ≤ 5.5 V	1/f _{MCK} +30		1/f _{MCK} +30		1/f _{MCK} +30		ns	
		1.7 V ≤ EV _{DD0} ≤ 5.5 V	1/f _{MCK} +40		1/f _{MCK} +40		1/f _{MCK} +40		ns	
		1.6 V ≤ EV _{DD0} ≤ 5.5 V	–		1/f _{MCK} +40		1/f _{MCK} +40		ns	
Slp hold time (from SCKp↑) ^{Note 2}	t _{KSJ2}	1.8 V ≤ EV _{DD0} ≤ 5.5 V	1/f _{MCK} +31		1/f _{MCK} +31		1/f _{MCK} +31		ns	
		1.7 V ≤ EV _{DD0} ≤ 5.5 V	1/f _{MCK} +250		1/f _{MCK} +250		1/f _{MCK} +250		ns	
		1.6 V ≤ EV _{DD0} ≤ 5.5 V	–		1/f _{MCK} +250		1/f _{MCK} +250		ns	
Delay time from SCKp↓ to SOp output ^{Note 3}	t _{KSO2}	C = 30 pF ^{Note 4}	2.7 V ≤ EV _{DD0} ≤ 5.5 V		2/f _{MCK} +44		2/f _{MCK} +110		2/f _{MCK} +110	ns
			2.4 V ≤ EV _{DD0} ≤ 5.5 V		2/f _{MCK} +75		2/f _{MCK} +110		2/f _{MCK} +110	ns
			1.8 V ≤ EV _{DD0} ≤ 5.5 V		2/f _{MCK} +110		2/f _{MCK} +110		2/f _{MCK} +110	ns
			1.7 V ≤ EV _{DD0} ≤ 5.5 V		2/f _{MCK} +220		2/f _{MCK} +220		2/f _{MCK} +220	ns
			1.6 V ≤ EV _{DD0} ≤ 5.5 V		–		2/f _{MCK} +220		2/f _{MCK} +220	ns

- Notes**
1. When DAP_{mn} = 0 and CKP_{mn} = 0, or DAP_{mn} = 1 and CKP_{mn} = 1. The Slp setup time becomes “to SCKp↓” when DAP_{mn} = 0 and CKP_{mn} = 1, or DAP_{mn} = 1 and CKP_{mn} = 0.
 2. When DAP_{mn} = 0 and CKP_{mn} = 0, or DAP_{mn} = 1 and CKP_{mn} = 1. The Slp hold time becomes “from SCKp↓” when DAP_{mn} = 0 and CKP_{mn} = 1, or DAP_{mn} = 1 and CKP_{mn} = 0.
 3. When DAP_{mn} = 0 and CKP_{mn} = 0, or DAP_{mn} = 1 and CKP_{mn} = 1. The delay time to SOp output becomes “from SCKp↑” when DAP_{mn} = 0 and CKP_{mn} = 1, or DAP_{mn} = 1 and CKP_{mn} = 0.
 4. C is the load capacitance of the SOp output lines.
 5. Transfer rate in the SNOOZE mode: MAX. 1 Mbps

Caution Select the normal input buffer for the Slp pin and SCKp pin and the normal output mode for the SOp pin by using port input mode register g (PIMg) and port output mode register g (POMg).

- Remarks**
1. p: CSI number (p = 00, 01, 10, 11, 20, 21, 30, 31), m: Unit number (m = 0, 1), n: Channel number (n = 0 to 3), g: PIM number (g = 0, 1, 4, 5, 8, 14)
 2. f_{MCK}: Serial array unit operation clock frequency (Operation clock to be set by the CKS_{mn} bit of serial mode register mn (SMR_{mn}). m: Unit number, n: Channel number (mn = 00 to 03, 10 to 13))

Simplified SPI (CSI) mode connection diagram (during communication at same potential)

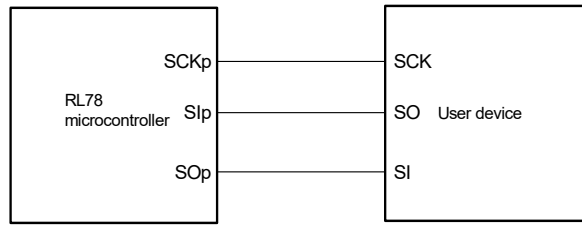

**Simplified SPI (CSI) mode serial transfer timing (during communication at same potential)
(When DAPmn = 0 and CKPmn = 0, or DAPmn = 1 and CKPmn = 1.)**

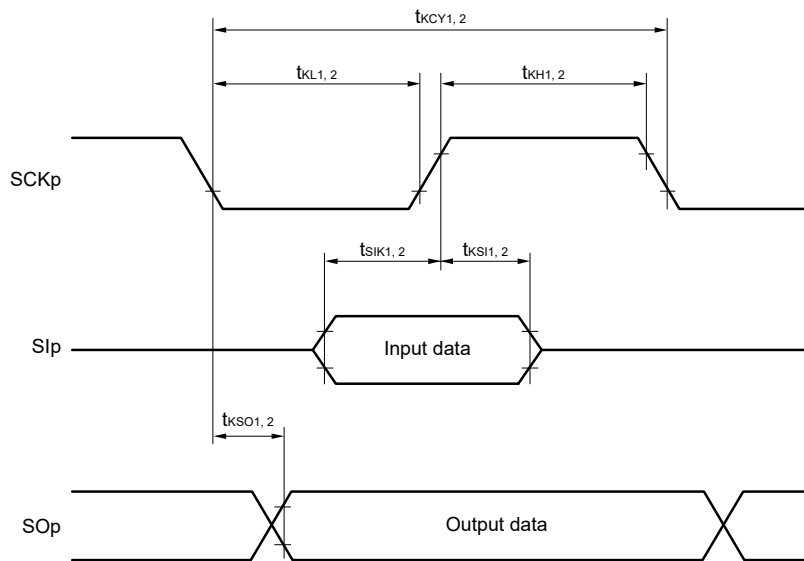

**Simplified SPI (CSI) mode serial transfer timing (during communication at same potential)
(When DAPmn = 0 and CKPmn = 1, or DAPmn = 1 and CKPmn = 0.)**

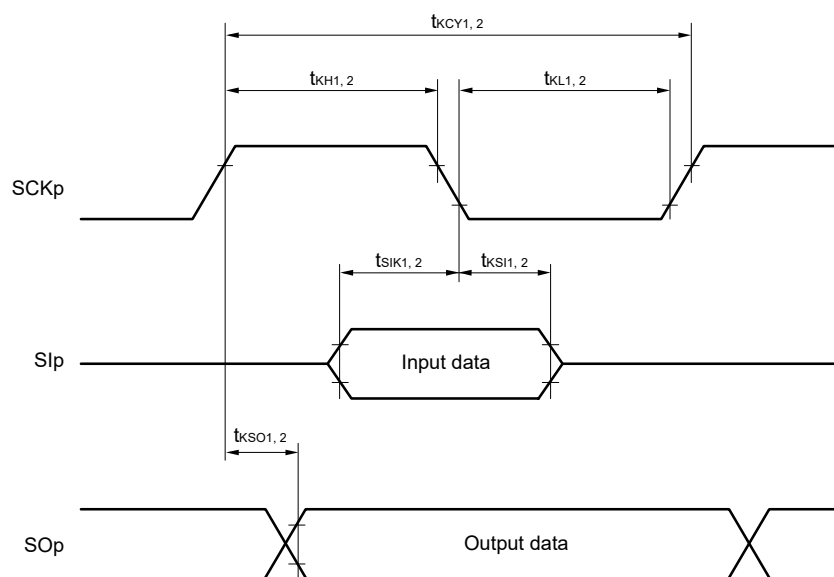

- Remarks 1.** p: CSI number (p = 00, 01, 10, 11, 20, 21, 30, 31)
2. m: Unit number, n: Channel number (mn = 00 to 03, 10 to 13)

(5) During communication at same potential (simplified I²C mode) (1/2)(T_A = -40 to +85°C, 1.6 V ≤ EV_{DD0} = EV_{DD1} ≤ V_{DD} ≤ 5.5 V, V_{SS} = EV_{SS0} = EV_{SS1} = 0 V)

Parameter	Symbol	Conditions	HS (high-speed main) Mode		LS (low-speed main) Mode		LV (low-voltage main) Mode		Unit
			MIN.	MAX.	MIN.	MAX.	MIN.	MAX.	
SCLr clock frequency	f _{SCL}	2.7 V ≤ EV _{DD0} ≤ 5.5 V, C _b = 50 pF, R _b = 2.7 kΩ		1000 Note 1		400 Note 1		400 Note 1	kHz
		1.8 V ≤ EV _{DD0} ≤ 5.5 V, C _b = 100 pF, R _b = 3 kΩ		400 Note 1		400 Note 1		400 Note 1	kHz
		1.8 V ≤ EV _{DD0} < 2.7 V, C _b = 100 pF, R _b = 5 kΩ		300 Note 1		300 Note 1		300 Note 1	kHz
		1.7 V ≤ EV _{DD0} < 1.8 V, C _b = 100 pF, R _b = 5 kΩ		250 Note 1		250 Note 1		250 Note 1	kHz
		1.6 V ≤ EV _{DD0} < 1.8 V, C _b = 100 pF, R _b = 5 kΩ		–		250 Note 1		250 Note 1	kHz
Hold time when SCLr = "L"	t _{LOW}	2.7 V ≤ EV _{DD0} ≤ 5.5 V, C _b = 50 pF, R _b = 2.7 kΩ	475		1150		1150		ns
		1.8 V ≤ EV _{DD0} ≤ 5.5 V, C _b = 100 pF, R _b = 3 kΩ	1150		1150		1150		ns
		1.8 V ≤ EV _{DD0} < 2.7 V, C _b = 100 pF, R _b = 5 kΩ	1550		1550		1550		ns
		1.7 V ≤ EV _{DD0} < 1.8 V, C _b = 100 pF, R _b = 5 kΩ	1850		1850		1850		ns
		1.6 V ≤ EV _{DD0} < 1.8 V, C _b = 100 pF, R _b = 5 kΩ	–		1850		1850		ns
Hold time when SCLr = "H"	t _{HIGH}	2.7 V ≤ EV _{DD0} ≤ 5.5 V, C _b = 50 pF, R _b = 2.7 kΩ	475		1150		1150		ns
		1.8 V ≤ EV _{DD0} ≤ 5.5 V, C _b = 100 pF, R _b = 3 kΩ	1150		1150		1150		ns
		1.8 V ≤ EV _{DD0} < 2.7 V, C _b = 100 pF, R _b = 5 kΩ	1550		1550		1550		ns
		1.7 V ≤ EV _{DD0} < 1.8 V, C _b = 100 pF, R _b = 5 kΩ	1850		1850		1850		ns
		1.6 V ≤ EV _{DD0} < 1.8 V, C _b = 100 pF, R _b = 5 kΩ	–		1850		1850		ns

(Notes and Caution are listed on the next page, and Remarks are listed on the page after the next page.)

(5) During communication at same potential (simplified I²C mode) (2/2)**(T_A = -40 to +85°C, 1.6 V ≤ EV_{DD0} = EV_{DD1} ≤ V_{DD} ≤ 5.5 V, V_{SS} = EV_{SS0} = EV_{SS1} = 0 V)**

Parameter	Symbol	Conditions	HS (high-speed main) Mode		LS (low-speed main) Mode		LV (low-voltage main) Mode		Unit
			MIN.	MAX.	MIN.	MAX.	MIN.	MAX.	
Data setup time (reception)	t _{SU:DAT}	2.7 V ≤ EV _{DD0} ≤ 5.5 V, C _b = 50 pF, R _b = 2.7 kΩ	1/f _{MCK} + 85 Note2		1/f _{MCK} + 145 Note2		1/f _{MCK} + 145 Note2		ns
		1.8 V ≤ EV _{DD0} ≤ 5.5 V, C _b = 100 pF, R _b = 3 kΩ	1/f _{MCK} + 145 Note2		1/f _{MCK} + 145 Note2		1/f _{MCK} + 145 Note2		ns
		1.8 V ≤ EV _{DD0} < 2.7 V, C _b = 100 pF, R _b = 5 kΩ	1/f _{MCK} + 230 Note2		1/f _{MCK} + 230 Note2		1/f _{MCK} + 230 Note2		ns
		1.7 V ≤ EV _{DD0} < 1.8 V, C _b = 100 pF, R _b = 5 kΩ	1/f _{MCK} + 290 Note2		1/f _{MCK} + 290 Note2		1/f _{MCK} + 290 Note2		ns
		1.6 V ≤ EV _{DD0} < 1.8 V, C _b = 100 pF, R _b = 5 kΩ	–		1/f _{MCK} + 290 Note2		1/f _{MCK} + 290 Note2		ns
Data hold time (transmission)	t _{HD:DAT}	2.7 V ≤ EV _{DD0} ≤ 5.5 V, C _b = 50 pF, R _b = 2.7 kΩ	0	305	0	305	0	305	ns
		1.8 V ≤ EV _{DD0} ≤ 5.5 V, C _b = 100 pF, R _b = 3 kΩ	0	355	0	355	0	355	ns
		1.8 V ≤ EV _{DD0} < 2.7 V, C _b = 100 pF, R _b = 5 kΩ	0	405	0	405	0	405	ns
		1.7 V ≤ EV _{DD0} < 1.8 V, C _b = 100 pF, R _b = 5 kΩ	0	405	0	405	0	405	ns
		1.6 V ≤ EV _{DD0} < 1.8 V, C _b = 100 pF, R _b = 5 kΩ	–		0	405	0	405	ns

- Notes**
1. The value must also be equal to or less than f_{MCK}/4.
 2. Set the f_{MCK} value to keep the hold time of SCLr = "L" and SCLr = "H".

Caution Select the normal input buffer and the N-ch open drain output (V_{DD} tolerance (When 20- to 52-pin products)/EV_{DD} tolerance (When 64- to 128-pin products)) mode for the SDAr pin and the normal output mode for the SCLr pin by using port input mode register g (PIMg) and port output mode register h (POMh).

(Remarks are listed on the next page.)

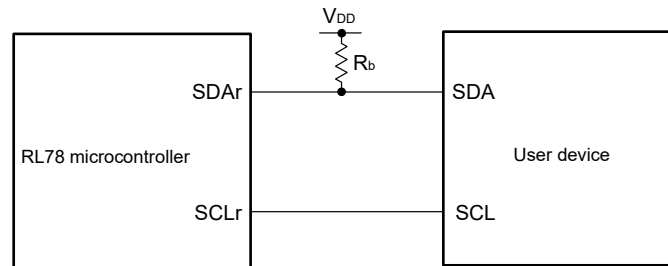
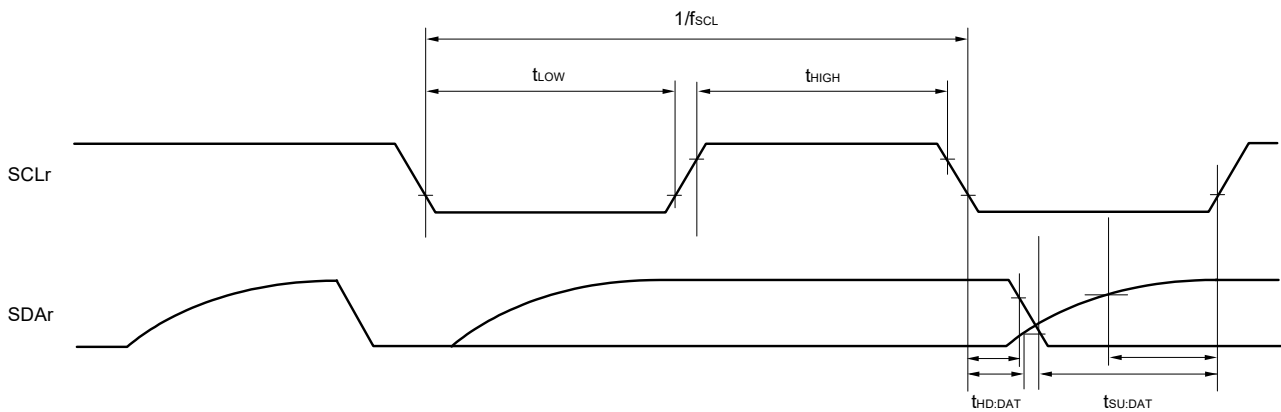
Simplified I²C mode connection diagram (during communication at same potential)**Simplified I²C mode serial transfer timing (during communication at same potential)**

- Remarks**
- $R_b[\Omega]$: Communication line (SDAr) pull-up resistance, $C_b[F]$: Communication line (SDAr, SCLr) load capacitance
 - r: IIC number (r = 00, 01, 10, 11, 20, 21, 30, 31), g: PIM number (g = 0, 1, 4, 5, 8, 14), h: POM number (g = 0, 1, 4, 5, 7 to 9, 14)
 - f_{MCK} : Serial array unit operation clock frequency
(Operation clock to be set by the CKSmn bit of serial mode register mn (SMRmn). m: Unit number (m = 0, 1), n: Channel number (n = 0 to 3), mn = 00 to 03, 10 to 13)

(6) Communication at different potential (1.8 V, 2.5 V, 3 V) (UART mode) (1/2)

(T_A = -40 to +85°C, 1.8 V ≤ EV_{DD0} = EV_{DD1} ≤ V_{DD} ≤ 5.5 V, V_{SS} = EV_{SS0} = EV_{SS1} = 0 V)

Parameter	Symbol	Conditions	HS (high-speed main) Mode		LS (low-speed main) Mode		LV (low-voltage main) Mode		Unit
			MIN.	MAX.	MIN.	MAX.	MIN.	MAX.	
Transfer rate	Reception	4.0 V ≤ EV _{DD0} ≤ 5.5 V, 2.7 V ≤ V _b ≤ 4.0 V		f _{MCK} /6 Note 1		f _{MCK} /6 Note 1		f _{MCK} /6 Note 1	bps
				5.3		1.3		0.6	Mbps
		2.7 V ≤ EV _{DD0} < 4.0 V, 2.3 V ≤ V _b ≤ 2.7 V		f _{MCK} /6 Note 1		f _{MCK} /6 Note 1		f _{MCK} /6 Note 1	bps
				5.3		1.3		0.6	Mbps
		1.8 V ≤ EV _{DD0} < 3.3 V, 1.6 V ≤ V _b ≤ 2.0 V		f _{MCK} /6 Notes 1 to 3		f _{MCK} /6 Notes 1, 2		f _{MCK} /6 Notes 1, 2	bps
				5.3		1.3		0.6	Mbps

- Notes**
- Transfer rate in the SNOOZE mode is 4800 bps only.
 - Use it with EV_{DD0} ≥ V_b.
 - The following conditions are required for low voltage interface when EV_{DD0} < V_{DD}.
 2.4 V ≤ EV_{DD0} < 2.7 V : MAX. 2.6 Mbps
 1.8 V ≤ EV_{DD0} < 2.4 V : MAX. 1.3 Mbps
 - The maximum operating frequencies of the CPU/peripheral hardware clock (f_{CLK}) are:
 HS (high-speed main) mode: 32 MHz (2.7 V ≤ V_{DD} ≤ 5.5 V)
 16 MHz (2.4 V ≤ V_{DD} ≤ 5.5 V)
 LS (low-speed main) mode: 8 MHz (1.8 V ≤ V_{DD} ≤ 5.5 V)
 LV (low-voltage main) mode: 4 MHz (1.6 V ≤ V_{DD} ≤ 5.5 V)

Caution Select the TTL input buffer for the Rx_{Dq} pin and the N-ch open drain output (V_{DD} tolerance (When 20- to 52-pin products)/EV_{DD} tolerance (When 64- to 128-pin products)) mode for the Tx_{Dq} pin by using port input mode register g (PIMg) and port output mode register g (POMg). For V_{IH} and V_{IL}, see the DC characteristics with TTL input buffer selected.

- Remarks**
- V_b[V]: Communication line voltage
 - q: UART number (q = 0 to 3), g: PIM and POM number (g = 0, 1, 8, 14)
 - f_{MCK}: Serial array unit operation clock frequency
 (Operation clock to be set by the CKSmn bit of serial mode register mn (SMRmn). m: Unit number, n: Channel number (mn = 00 to 03, 10 to 13))
 - UART2 cannot communicate at different potential when bit 1 (PIOR1) of peripheral I/O redirection register (PIOR) is 1.

(6) Communication at different potential (1.8 V, 2.5 V, 3 V) (UART mode) (2/2)

(T_A = -40 to +85°C, 1.8 V ≤ EV_{DD0} = EV_{DD1} ≤ V_{DD} ≤ 5.5 V, V_{SS} = EV_{SS0} = EV_{SS1} = 0 V)

Parameter	Symbol	Conditions	HS (high-speed main) Mode		LS (low-speed main) Mode		LV (low-voltage main) Mode		Unit			
			MIN.	MAX.	MIN.	MAX.	MIN.	MAX.				
Transfer rate		Transmission	4.0 V ≤ EV _{DD0} ≤ 5.5 V, 2.7 V ≤ V _b ≤ 4.0 V			Note 1		Note 1		Note 1	bps	
			Theoretical value of the maximum transfer rate C _b = 50 pF, R _b = 1.4 kΩ, V _b = 2.7 V			2.8 <small>Note 2</small>		2.8 <small>Note 2</small>		2.8 <small>Note 2</small>		Mbps
			2.7 V ≤ EV _{DD0} < 4.0 V, 2.3 V ≤ V _b ≤ 2.7 V			Note 3		Note 3		Note 3		bps
			Theoretical value of the maximum transfer rate C _b = 50 pF, R _b = 2.7 kΩ, V _b = 2.3 V			1.2 <small>Note 4</small>		1.2 <small>Note 4</small>		1.2 <small>Note 4</small>		Mbps
			1.8 V ≤ EV _{DD0} < 3.3 V, 1.6 V ≤ V _b ≤ 2.0 V			Notes 5, 6		Notes 5, 6		Notes 5, 6	bps	
			Theoretical value of the maximum transfer rate C _b = 50 pF, R _b = 5.5 kΩ, V _b = 1.6 V			0.43 <small>Note 7</small>		0.43 <small>Note 7</small>		0.43 <small>Note 7</small>		Mbps

Notes 1. The smaller maximum transfer rate derived by using f_{MCK}/6 or the following expression is the valid maximum transfer rate.

Expression for calculating the transfer rate when 4.0 V ≤ EV_{DD0} ≤ 5.5 V and 2.7 V ≤ V_b ≤ 4.0 V

$$\text{Maximum transfer rate} = \frac{1}{\{-C_b \times R_b \times \ln(1 - \frac{2.2}{V_b})\} \times 3} \text{ [bps]}$$

$$\text{Baud rate error (theoretical value)} = \frac{\frac{1}{\text{Transfer rate} \times 2} - \{-C_b \times R_b \times \ln(1 - \frac{2.2}{V_b})\}}{(\frac{1}{\text{Transfer rate}}) \times \text{Number of transferred bits}} \times 100 \text{ [%]}$$

* This value is the theoretical value of the relative difference between the transmission and reception sides.

- This value as an example is calculated when the conditions described in the “Conditions” column are met. Refer to Note 1 above to calculate the maximum transfer rate under conditions of the customer.

Notes 3. The smaller maximum transfer rate derived by using $f_{MCK}/6$ or the following expression is the valid maximum transfer rate.

Expression for calculating the transfer rate when $2.7\text{ V} \leq EV_{DD0} < 4.0\text{ V}$ and $2.3\text{ V} \leq V_b \leq 2.7\text{ V}$

$$\text{Maximum transfer rate} = \frac{1}{\{-C_b \times R_b \times \ln(1 - \frac{2.0}{V_b})\} \times 3} \text{ [bps]}$$

$$\text{Baud rate error (theoretical value)} = \frac{\frac{1}{\text{Transfer rate} \times 2} - \{-C_b \times R_b \times \ln(1 - \frac{2.0}{V_b})\}}{(\frac{1}{\text{Transfer rate}}) \times \text{Number of transferred bits}} \times 100 \text{ [%]}$$

* This value is the theoretical value of the relative difference between the transmission and reception sides.

4. This value as an example is calculated when the conditions described in the “Conditions” column are met. Refer to Note 3 above to calculate the maximum transfer rate under conditions of the customer.
5. Use it with $EV_{DD0} \geq V_b$.
6. The smaller maximum transfer rate derived by using $f_{MCK}/6$ or the following expression is the valid maximum transfer rate.

Expression for calculating the transfer rate when $1.8\text{ V} \leq EV_{DD0} < 3.3\text{ V}$ and $1.6\text{ V} \leq V_b \leq 2.0\text{ V}$

$$\text{Maximum transfer rate} = \frac{1}{\{-C_b \times R_b \times \ln(1 - \frac{1.5}{V_b})\} \times 3} \text{ [bps]}$$

$$\text{Baud rate error (theoretical value)} = \frac{\frac{1}{\text{Transfer rate} \times 2} - \{-C_b \times R_b \times \ln(1 - \frac{1.5}{V_b})\}}{(\frac{1}{\text{Transfer rate}}) \times \text{Number of transferred bits}} \times 100 \text{ [%]}$$

* This value is the theoretical value of the relative difference between the transmission and reception sides.

7. This value as an example is calculated when the conditions described in the “Conditions” column are met. Refer to Note 6 above to calculate the maximum transfer rate under conditions of the customer.

Caution Select the TTL input buffer for the RxDq pin and the N-ch open drain output (V_{DD} tolerance (When 20- to 52-pin products)/EV_{DD} tolerance (When 64- to 128-pin products)) mode for the TxDq pin by using port input mode register g (PIMg) and port output mode register g (POMg). For V_{IH} and V_{IL}, see the DC characteristics with TTL input buffer selected.

UART mode connection diagram (during communication at different potential)

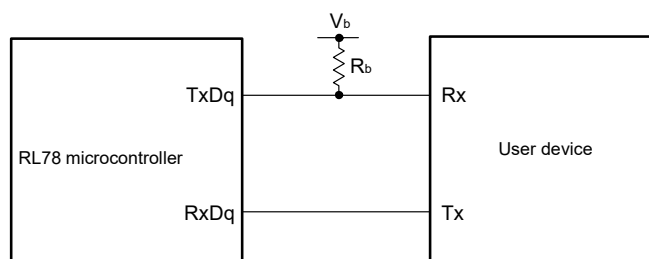

UART mode bit width (during communication at different potential) (reference)

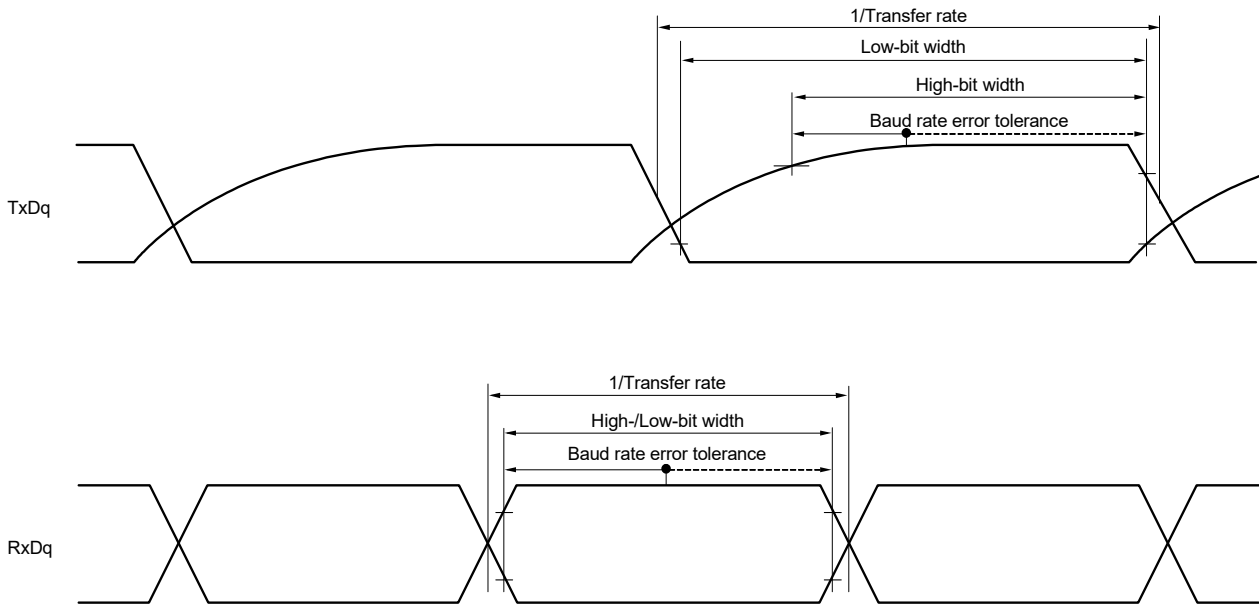

- Remarks 1.** $R_b[\Omega]$: Communication line (TxDq) pull-up resistance,
 $C_b[\text{F}]$: Communication line (TxDq) load capacitance, $V_b[\text{V}]$: Communication line voltage
- 2.** q : UART number ($q = 0$ to 3), g : PIM and POM number ($g = 0, 1, 8, 14$)
- 3.** f_{MCK} : Serial array unit operation clock frequency
 (Operation clock to be set by the CKSmn bit of serial mode register mn (SMRmn).
 m : Unit number, n : Channel number ($mn = 00$ to $03, 10$ to 13))
- 4.** UART2 cannot communicate at different potential when bit 1 (PIOR1) of peripheral I/O redirection register (PIOR) is 1.

(7) Communication at different potential (2.5 V, 3 V) (Simplified SPI (CSI) mode) (master mode, SCKp... internal clock output, corresponding CSI00 only) (1/2)**(T_A = -40 to +85°C, 2.7 V ≤ EV_{DD0} = EV_{DD1} ≤ V_{DD} ≤ 5.5 V, V_{SS} = EV_{SS0} = EV_{SS1} = 0 V)**

Parameter	Symbol	Conditions	HS (high-speed main) Mode		LS (low-speed main) Mode		LV (low-voltage main) Mode		Unit
			MIN.	MAX.	MIN.	MAX.	MIN.	MAX.	
SCKp cycle time	t _{KCY1}	t _{KCY1} ≥ 2/f _{CLK} 4.0 V ≤ EV _{DD0} ≤ 5.5 V, 2.7 V ≤ V _b ≤ 4.0 V, C _b = 20 pF, R _b = 1.4 kΩ	200		1150		1150		ns
		2.7 V ≤ EV _{DD0} < 4.0 V, 2.3 V ≤ V _b ≤ 2.7 V, C _b = 20 pF, R _b = 2.7 kΩ	300		1150		1150		ns
SCKp high-level width	t _{KH1}	4.0 V ≤ EV _{DD0} ≤ 5.5 V, 2.7 V ≤ V _b ≤ 4.0 V, C _b = 20 pF, R _b = 1.4 kΩ	t _{KCY1} /2 – 50		t _{KCY1} /2 – 50		t _{KCY1} /2 – 50		ns
		2.7 V ≤ EV _{DD0} < 4.0 V, 2.3 V ≤ V _b ≤ 2.7 V, C _b = 20 pF, R _b = 2.7 kΩ	t _{KCY1} /2 – 120		t _{KCY1} /2 – 120		t _{KCY1} /2 – 120		ns
SCKp low-level width	t _{KL1}	4.0 V ≤ EV _{DD0} ≤ 5.5 V, 2.7 V ≤ V _b ≤ 4.0 V, C _b = 20 pF, R _b = 1.4 kΩ	t _{KCY1} /2 – 7		t _{KCY1} /2 – 50		t _{KCY1} /2 – 50		ns
		2.7 V ≤ EV _{DD0} < 4.0 V, 2.3 V ≤ V _b ≤ 2.7 V, C _b = 20 pF, R _b = 2.7 kΩ	t _{KCY1} /2 – 10		t _{KCY1} /2 – 50		t _{KCY1} /2 – 50		ns
Slp setup time (to SCKp↑) ^{Note 1}	t _{SIK1}	4.0 V ≤ EV _{DD0} ≤ 5.5 V, 2.7 V ≤ V _b ≤ 4.0 V, C _b = 20 pF, R _b = 1.4 kΩ	58		479		479		ns
		2.7 V ≤ EV _{DD0} < 4.0 V, 2.3 V ≤ V _b ≤ 2.7 V, C _b = 20 pF, R _b = 2.7 kΩ	121		479		479		ns
Slp hold time (from SCKp↑) ^{Note 1}	t _{KSH1}	4.0 V ≤ EV _{DD0} ≤ 5.5 V, 2.7 V ≤ V _b ≤ 4.0 V, C _b = 20 pF, R _b = 1.4 kΩ	10		10		10		ns
		2.7 V ≤ EV _{DD0} < 4.0 V, 2.3 V ≤ V _b ≤ 2.7 V, C _b = 20 pF, R _b = 2.7 kΩ	10		10		10		ns
Delay time from SCKp↓ to SOP output ^{Note 1}	t _{KSO1}	4.0 V ≤ EV _{DD0} ≤ 5.5 V, 2.7 V ≤ V _b ≤ 4.0 V, C _b = 20 pF, R _b = 1.4 kΩ		60		60		60	ns
		2.7 V ≤ EV _{DD0} < 4.0 V, 2.3 V ≤ V _b ≤ 2.7 V, C _b = 20 pF, R _b = 2.7 kΩ		130		130		130	ns

(Notes, Caution, and Remarks are listed on the next page.)

(7) Communication at different potential (2.5 V, 3 V) (Simplified SPI (CSI) mode) (master mode, SCKp... internal clock output, corresponding CSI00 only) (2/2)**(T_A = -40 to +85°C, 2.7 V ≤ EV_{DD0} = EV_{DD1} ≤ V_{DD} ≤ 5.5 V, V_{SS} = EV_{SS0} = EV_{SS1} = 0 V)**

Parameter	Symbol	Conditions	HS (high-speed main) Mode		LS (low-speed main) Mode		LV (low-voltage main) Mode		Unit
			MIN.	MAX.	MIN.	MAX.	MIN.	MAX.	
Slp setup time (to SCKp↓) ^{Note 2}	t _{SIK1}	4.0 V ≤ EV _{DD0} ≤ 5.5 V, 2.7 V ≤ V _b ≤ 4.0 V, C _b = 20 pF, R _b = 1.4 kΩ	23		110		110		ns
		2.7 V ≤ EV _{DD0} < 4.0 V, 2.3 V ≤ V _b ≤ 2.7 V, C _b = 20 pF, R _b = 2.7 kΩ	33		110		110		ns
Slp hold time (from SCKp↓) ^{Note 2}	t _{KS11}	4.0 V ≤ EV _{DD0} ≤ 5.5 V, 2.7 V ≤ V _b ≤ 4.0 V, C _b = 20 pF, R _b = 1.4 kΩ	10		10		10		ns
		2.7 V ≤ EV _{DD0} < 4.0 V, 2.3 V ≤ V _b ≤ 2.7 V, C _b = 20 pF, R _b = 2.7 kΩ	10		10		10		ns
Delay time from SCKp↑ to SO _p output ^{Note 2}	t _{KSO1}	4.0 V ≤ EV _{DD0} ≤ 5.5 V, 2.7 V ≤ V _b ≤ 4.0 V, C _b = 20 pF, R _b = 1.4 kΩ		10	10		10		ns
		2.7 V ≤ EV _{DD0} < 4.0 V, 2.3 V ≤ V _b ≤ 2.7 V, C _b = 20 pF, R _b = 2.7 kΩ		10	10		10		ns

Notes 1. When DAP_{mn} = 0 and CKP_{mn} = 0, or DAP_{mn} = 1 and CKP_{mn} = 1.2. When DAP_{mn} = 0 and CKP_{mn} = 1, or DAP_{mn} = 1 and CKP_{mn} = 0.

Caution Select the TTL input buffer for the Slp pin and the N-ch open drain output (V_{DD} tolerance (When 20- to 52-pin products)/EV_{DD} tolerance (When 64- to 128-pin products)) mode for the SO_p pin and SCKp pin by using port input mode register g (PIMg) and port output mode register g (POMg). For V_{IH} and V_{IL}, see the DC characteristics with TTL input buffer selected.

- Remarks**
- R_b[Ω]: Communication line (SCKp, SO_p) pull-up resistance, C_b[F]: Communication line (SCKp, SO_p) load capacitance, V_b[V]: Communication line voltage
 - p: CSI number (p = 00), m: Unit number (m = 0), n: Channel number (n = 0),
g: PIM and POM number (g = 1)
 - f_{MCK}: Serial array unit operation clock frequency
(Operation clock to be set by the CKS_{mn} bit of serial mode register mn (SMR_{mn}). m: Unit number, n: Channel number (mn = 00))
 - This value is valid only when CSI00's peripheral I/O redirect function is not used.

(8) Communication at different potential (1.8 V, 2.5 V, 3 V) (Simplified SPI (CSI) mode) (master mode, SCKp... internal clock output) (1/3)**(T_A = -40 to +85°C, 1.8 V ≤ EV_{DD0} = EV_{DD1} ≤ V_{DD} ≤ 5.5 V, V_{SS} = EV_{SS0} = EV_{SS1} = 0 V)**

Parameter	Symbol	Conditions	HS (high-speed main) Mode		LS (low-speed main) Mode		LV (low-voltage main) Mode		Unit
			MIN.	MAX.	MIN.	MAX.	MIN.	MAX.	
SCKp cycle time	t _{KCY1}	t _{KCY1} ≥ 4/f _{CLK} 4.0 V ≤ EV _{DD0} ≤ 5.5 V, 2.7 V ≤ V _b ≤ 4.0 V, C _b = 30 pF, R _b = 1.4 kΩ	300		1150		1150		ns
			500		1150		1150		ns
			1150		1150		1150		ns
SCKp high-level width	t _{KH1}	4.0 V ≤ EV _{DD0} ≤ 5.5 V, 2.7 V ≤ V _b ≤ 4.0 V, C _b = 30 pF, R _b = 1.4 kΩ	t _{KCY1} /2 – 75		t _{KCY1} /2 – 75		t _{KCY1} /2 – 75		ns
			t _{KCY1} /2 – 170		t _{KCY1} /2 – 170		t _{KCY1} /2 – 170		ns
			t _{KCY1} /2 – 458		t _{KCY1} /2 – 458		t _{KCY1} /2 – 458		ns
SCKp low-level width	t _{KL1}	4.0 V ≤ EV _{DD0} ≤ 5.5 V, 2.7 V ≤ V _b ≤ 4.0 V, C _b = 30 pF, R _b = 1.4 kΩ	t _{KCY1} /2 – 12		t _{KCY1} /2 – 50		t _{KCY1} /2 – 50		ns
			t _{KCY1} /2 – 18		t _{KCY1} /2 – 50		t _{KCY1} /2 – 50		ns
			t _{KCY1} /2 – 50		t _{KCY1} /2 – 50		t _{KCY1} /2 – 50		ns

Note Use it with EV_{DD0} ≥ V_b.

Caution Select the TTL input buffer for the Slp pin and the N-ch open drain output (V_{DD} tolerance (When 20- to 52-pin products)/EV_{DD} tolerance (When 64- to 128-pin products)) mode for the SOp pin and SCKp pin by using port input mode register g (PIMg) and port output mode register g (POMg). For V_{IH} and V_{IL}, see the DC characteristics with TTL input buffer selected.

(Remarks are listed two pages after the next page.)

(8) Communication at different potential (1.8 V, 2.5 V, 3 V) (Simplified SPI (CSI) mode) (master mode, SCKp... internal clock output) (2/3)**(T_A = -40 to +85°C, 1.8 V ≤ EV_{DD0} = EV_{DD1} ≤ V_{DD} ≤ 5.5 V, V_{SS} = EV_{SS0} = EV_{SS1} = 0 V)**

Parameter	Symbol	Conditions	HS (high-speed main) Mode		LS (low-speed main) Mode		LV (low-voltage main) Mode		Unit
			MIN.	MAX.	MIN.	MAX.	MIN.	MAX.	
Slp setup time (to SCKp↑) ^{Note 1}	t _{SIK1}	4.0 V ≤ EV _{DD0} ≤ 5.5 V, 2.7 V ≤ V _b ≤ 4.0 V, C _b = 30 pF, R _b = 1.4 kΩ	81		479		479		ns
		2.7 V ≤ EV _{DD0} < 4.0 V, 2.3 V ≤ V _b ≤ 2.7 V, C _b = 30 pF, R _b = 2.7 kΩ	177		479		479		ns
		1.8 V ≤ EV _{DD0} < 3.3 V, 1.6 V ≤ V _b ≤ 2.0 V ^{Note 2} , C _b = 30 pF, R _b = 5.5 kΩ	479		479		479		ns
Slp hold time (from SCKp↑) ^{Note 1}	t _{KS11}	4.0 V ≤ EV _{DD0} ≤ 5.5 V, 2.7 V ≤ V _b ≤ 4.0 V, C _b = 30 pF, R _b = 1.4 kΩ	19		19		19		ns
		2.7 V ≤ EV _{DD0} < 4.0 V, 2.3 V ≤ V _b ≤ 2.7 V, C _b = 30 pF, R _b = 2.7 kΩ	19		19		19		ns
		1.8 V ≤ EV _{DD0} < 3.3 V, 1.6 V ≤ V _b ≤ 2.0 V ^{Note 2} , C _b = 30 pF, R _b = 5.5 kΩ	19		19		19		ns
Delay time from SCKp↓ to SOp output ^{Note 1}	t _{KSO1}	4.0 V ≤ EV _{DD0} ≤ 5.5 V, 2.7 V ≤ V _b ≤ 4.0 V, C _b = 30 pF, R _b = 1.4 kΩ		100		100		100	ns
		2.7 V ≤ EV _{DD0} < 4.0 V, 2.3 V ≤ V _b ≤ 2.7 V, C _b = 30 pF, R _b = 2.7 kΩ		195		195		195	ns
		1.8 V ≤ EV _{DD0} < 3.3 V, 1.6 V ≤ V _b ≤ 2.0 V ^{Note 2} , C _b = 30 pF, R _b = 5.5 kΩ		483		483		483	ns

- Notes**
1. When DAP_{mn} = 0 and CKP_{mn} = 0, or DAP_{mn} = 1 and CKP_{mn} = 1.
 2. Use it with EV_{DD0} ≥ V_b.

Caution Select the TTL input buffer for the Slp pin and the N-ch open drain output (V_{DD} tolerance (When 20- to 52-pin products)/EV_{DD} tolerance (When 64- to 128-pin products)) mode for the SOp pin and SCKp pin by using port input mode register g (PIMg) and port output mode register g (POMg). For V_{IH} and V_{IL}, see the DC characteristics with TTL input buffer selected.

(Remarks are listed on the page after the next page.)

(8) Communication at different potential (1.8 V, 2.5 V, 3 V) (Simplified SPI (CSI) mode) (master mode, SCKp... internal clock output) (3/3)**(T_A = -40 to +85°C, 1.8 V ≤ EV_{DD0} = EV_{DD1} ≤ V_{DD} ≤ 5.5 V, V_{SS} = EV_{SS0} = EV_{SS1} = 0 V)**

Parameter	Symbol	Conditions	HS (high-speed main) Mode		LS (low-speed main) Mode		LV (low-voltage main) Mode		Unit
			MIN.	MAX.	MIN.	MAX.	MIN.	MAX.	
Slp setup time (to SCKp↓) ^{Note 1}	t _{SIK1}	4.0 V ≤ EV _{DD0} ≤ 5.5 V, 2.7 V ≤ V _b ≤ 4.0 V, C _b = 30 pF, R _b = 1.4 kΩ	44		110		110		ns
		2.7 V ≤ EV _{DD0} < 4.0 V, 2.3 V ≤ V _b ≤ 2.7 V, C _b = 30 pF, R _b = 2.7 kΩ	44		110		110		ns
		1.8 V ≤ EV _{DD0} < 3.3 V, 1.6 V ≤ V _b ≤ 2.0 V ^{Note 2} , C _b = 30 pF, R _b = 5.5 kΩ	110		110		110		ns
Slp hold time (from SCKp↓) ^{Note 1}	t _{KS11}	4.0 V ≤ EV _{DD0} ≤ 5.5 V, 2.7 V ≤ V _b ≤ 4.0 V, C _b = 30 pF, R _b = 1.4 kΩ	19		19		19		ns
		2.7 V ≤ EV _{DD0} < 4.0 V, 2.3 V ≤ V _b ≤ 2.7 V, C _b = 30 pF, R _b = 2.7 kΩ	19		19		19		ns
		1.8 V ≤ EV _{DD0} < 3.3 V, 1.6 V ≤ V _b ≤ 2.0 V ^{Note 2} , C _b = 30 pF, R _b = 5.5 kΩ	19		19		19		ns
Delay time from SCKp↑ to SOp output ^{Note 1}	t _{KSO1}	4.0 V ≤ EV _{DD0} ≤ 5.5 V, 2.7 V ≤ V _b ≤ 4.0 V, C _b = 30 pF, R _b = 1.4 kΩ		25		25		25	ns
		2.7 V ≤ EV _{DD0} < 4.0 V, 2.3 V ≤ V _b ≤ 2.7 V, C _b = 30 pF, R _b = 2.7 kΩ		25		25		25	ns
		1.8 V ≤ EV _{DD0} < 3.3 V, 1.6 V ≤ V _b ≤ 2.0 V ^{Note 2} , C _b = 30 pF, R _b = 5.5 kΩ		25		25		25	ns

- Notes**
1. When DAPmn = 0 and CKPmn = 1, or DAPmn = 1 and CKPmn = 0.
 2. Use it with EV_{DD0} ≥ V_b.

Caution Select the TTL input buffer for the Slp pin and the N-ch open drain output (V_{DD} tolerance (When 20- to 52-pin products)/EV_{DD} tolerance (When 64- to 128-pin products)) mode for the SOp pin and SCKp pin by using port input mode register g (PIMg) and port output mode register g (POMg). For V_{IH} and V_{IL}, see the DC characteristics with TTL input buffer selected.

(Remarks are listed on the next page.)

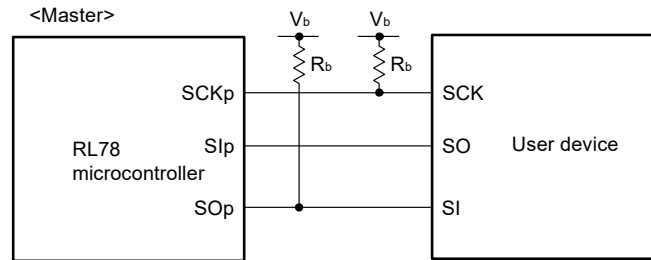
Simplified SPI (CSI) mode connection diagram (during communication at different potential)

- Remarks**
- $R_b[\Omega]$: Communication line (SCKp, SOP) pull-up resistance, $C_b[F]$: Communication line (SCKp, SOP) load capacitance, $V_b[V]$: Communication line voltage
 - p: CSI number ($p = 00, 01, 10, 20, 30, 31$), m: Unit number, n: Channel number ($mn = 00, 01, 02, 10, 12, 13$), g: PIM and POM number ($g = 0, 1, 4, 5, 8, 14$)
 - f_{MCK} : Serial array unit operation clock frequency
(Operation clock to be set by the CKSmn bit of serial mode register mn (SMRmn).
m: Unit number, n: Channel number ($mn = 00$))
 - CSI01 of 48-, 52-, 64-pin products, and CSI11 and CSI21 cannot communicate at different potential. Use other CSI for communication at different potential.

**Simplified SPI (CSI) mode serial transfer timing (master mode) (during communication at different potential)
(When DAPmn = 0 and CKPmn = 0, or DAPmn = 1 and CKPmn = 1.)**

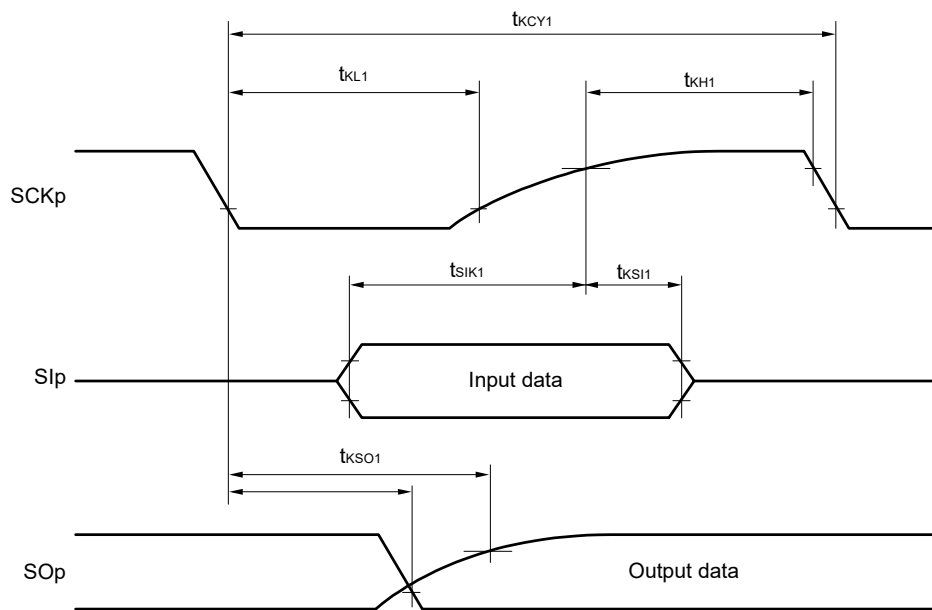

**Simplified SPI (CSI) mode serial transfer timing (master mode) (during communication at different potential)
(When DAPmn = 0 and CKPmn = 1, or DAPmn = 1 and CKPmn = 0.)**

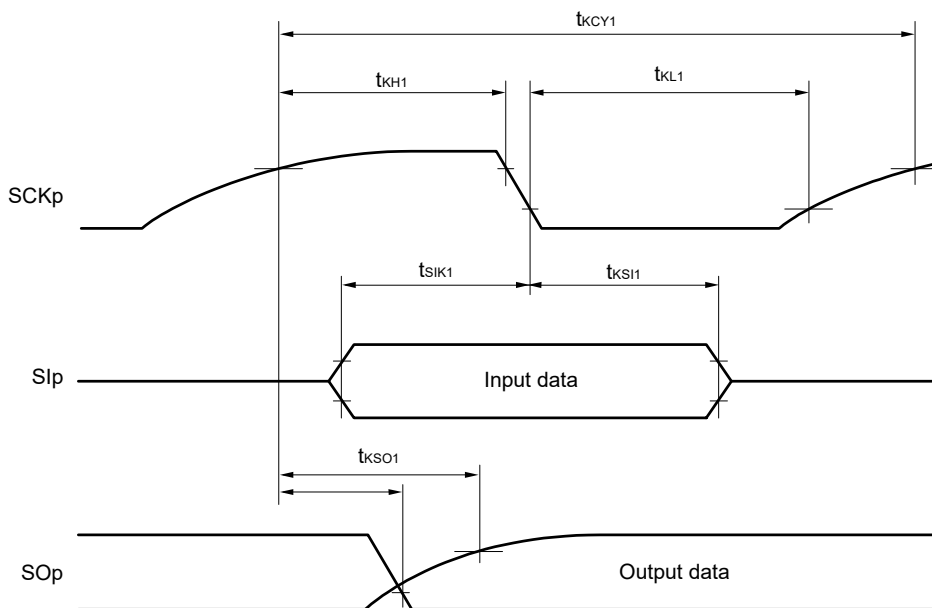

- Remarks**
1. p: CSI number (p = 00, 01, 10, 20, 30, 31), m: Unit number, n: Channel number (mn = 00, 01, 02, 10, 12, 13), g: PIM and POM number (g = 0, 1, 4, 5, 8, 14)
 2. CSI01 of 48-, 52-, 64-pin products, and CSI11 and CSI21 cannot communicate at different potential. Use other CSI for communication at different potential.

(9) Communication at different potential (1.8 V, 2.5 V, 3 V) (Simplified SPI (CSI) mode) (slave mode, SCKp... external clock input)**(T_A = -40 to +85°C, 1.8 V ≤ EV_{DD0} = EV_{DD1} ≤ V_{DD} ≤ 5.5 V, V_{SS} = EV_{SS0} = EV_{SS1} = 0 V) (1/2)**

Parameter	Symbol	Conditions		HS (high-speed main) Mode		LS (low-speed main) Mode		LV (low-voltage main) Mode		Unit
				MIN.	MAX.	MIN.	MAX.	MIN.	MAX.	
SCKp cycle time ^{Note 1}	t _{KCY2}	4.0 V ≤ EV _{DD0} ≤ 5.5 V, 2.7 V ≤ V _b ≤ 4.0 V	24 MHz < f _{MCK}	14/ f _{MCK}		–		–		ns
			20 MHz < f _{MCK} ≤ 24 MHz	12/ f _{MCK}		–		–		ns
			8 MHz < f _{MCK} ≤ 20 MHz	10/ f _{MCK}		–		–		ns
			4 MHz < f _{MCK} ≤ 8 MHz	8/f _{MCK}		16/ f _{MCK}		–		ns
			f _{MCK} ≤ 4 MHz	6/f _{MCK}		10/ f _{MCK}		10/ f _{MCK}		ns
		2.7 V ≤ EV _{DD0} < 4.0 V, 2.3 V ≤ V _b ≤ 2.7 V	24 MHz < f _{MCK}	20/ f _{MCK}		–		–		ns
			20 MHz < f _{MCK} ≤ 24 MHz	16/ f _{MCK}		–		–		ns
			16 MHz < f _{MCK} ≤ 20 MHz	14/ f _{MCK}		–		–		ns
			8 MHz < f _{MCK} ≤ 16 MHz	12/ f _{MCK}		–		–		ns
			4 MHz < f _{MCK} ≤ 8 MHz	8/f _{MCK}		16/ f _{MCK}		–		ns
			f _{MCK} ≤ 4 MHz	6/f _{MCK}		10/ f _{MCK}		10/ f _{MCK}		ns
		1.8 V ≤ EV _{DD0} < 3.3 V, 1.6 V ≤ V _b ≤ 2.0 V ^{Note 2}	24 MHz < f _{MCK}	48/ f _{MCK}		–		–		ns
			20 MHz < f _{MCK} ≤ 24 MHz	36/ f _{MCK}		–		–		ns
			16 MHz < f _{MCK} ≤ 20 MHz	32/ f _{MCK}		–		–		ns
			8 MHz < f _{MCK} ≤ 16 MHz	26/ f _{MCK}		–		–		ns
			4 MHz < f _{MCK} ≤ 8 MHz	16/ f _{MCK}		16/ f _{MCK}		–		ns
			f _{MCK} ≤ 4 MHz	10/ f _{MCK}		10/ f _{MCK}		10/ f _{MCK}		ns

(Notes and Caution are listed on the next page, and Remarks are listed on the page after the next page.)

(9) Communication at different potential (1.8 V, 2.5 V, 3 V) (Simplified SPI (CSI) mode) (slave mode, SCKp... external clock input)**(T_A = -40 to +85°C, 1.8 V ≤ EV_{DD0} = EV_{DD1} ≤ V_{DD} ≤ 5.5 V, V_{SS} = EV_{SS0} = EV_{SS1} = 0 V) (2/2)**

Parameter	Symbol	Conditions	HS (high-speed main) Mode		LS (low-speed main) Mode		LV (low-voltage main) Mode		Unit
			MIN.	MAX.	MIN.	MAX.	MIN.	MAX.	
SCKp high-/low-level width	t _{KH2} , t _{KL2}	4.0 V ≤ EV _{DD0} ≤ 5.5 V, 2.7 V ≤ V _b ≤ 4.0 V	t _{KCY2} /2 – 12		t _{KCY2} /2 – 50		t _{KCY2} /2 – 50		ns
		2.7 V ≤ EV _{DD0} < 4.0 V, 2.3 V ≤ V _b ≤ 2.7 V	t _{KCY2} /2 – 18		t _{KCY2} /2 – 50		t _{KCY2} /2 – 50		ns
		1.8 V ≤ EV _{DD0} < 3.3 V, 1.6 V ≤ V _b ≤ 2.0 V ^{Note 2}	t _{KCY2} /2 – 50		t _{KCY2} /2 – 50		t _{KCY2} /2 – 50		ns
Slp setup time (to SCKp↑) ^{Note 3}	t _{SIK2}	4.0 V ≤ EV _{DD0} ≤ 5.5 V, 2.7 V ≤ V _b ≤ 4.0 V	1/f _{MCK} + 20		1/f _{MCK} + 30		1/f _{MCK} + 30		ns
		2.7 V ≤ EV _{DD0} < 4.0 V, 2.3 V ≤ V _b ≤ 2.7 V	1/f _{MCK} + 20		1/f _{MCK} + 30		1/f _{MCK} + 30		ns
		1.8 V ≤ EV _{DD0} < 3.3 V, 1.6 V ≤ V _b ≤ 2.0 V ^{Note 2}	1/f _{MCK} + 30		1/f _{MCK} + 30		1/f _{MCK} + 30		ns
Slp hold time (from SCKp↑) ^{Note 4}	t _{SI2}		1/f _{MCK} + 31		1/f _{MCK} + 31		1/f _{MCK} + 31		ns
Delay time from SCKp↓ to SOp output ^{Note 5}	t _{KSO2}	4.0 V ≤ EV _{DD0} ≤ 5.5 V, 2.7 V ≤ V _b ≤ 4.0 V, C _b = 30 pF, R _b = 1.4 kΩ		2/f _{MCK} + 120		2/f _{MCK} + 573		2/f _{MCK} + 573	ns
		2.7 V ≤ EV _{DD0} < 4.0 V, 2.3 V ≤ V _b ≤ 2.7 V, C _b = 30 pF, R _b = 2.7 kΩ		2/f _{MCK} + 214		2/f _{MCK} + 573		2/f _{MCK} + 573	ns
		1.8 V ≤ EV _{DD0} < 3.3 V, 1.6 V ≤ V _b ≤ 2.0 V ^{Note 2} , C _b = 30 pF, R _b = 5.5 kΩ		2/f _{MCK} + 573		2/f _{MCK} + 573		2/f _{MCK} + 573	ns

Notes 1. Transfer rate in the SNOOZE mode : MAX. 1 Mbps2. Use it with EV_{DD0} ≥ V_b.3. When DAP_{mn} = 0 and CKP_{mn} = 0, or DAP_{mn} = 1 and CKP_{mn} = 1. The Slp setup time becomes “to SCKp↓” when DAP_{mn} = 0 and CKP_{mn} = 1, or DAP_{mn} = 1 and CKP_{mn} = 0.4. When DAP_{mn} = 0 and CKP_{mn} = 0, or DAP_{mn} = 1 and CKP_{mn} = 1. The Slp hold time becomes “from SCKp↓” when DAP_{mn} = 0 and CKP_{mn} = 1, or DAP_{mn} = 1 and CKP_{mn} = 0.5. When DAP_{mn} = 0 and CKP_{mn} = 0, or DAP_{mn} = 1 and CKP_{mn} = 1. The delay time to SOp output becomes “from SCKp↑” when DAP_{mn} = 0 and CKP_{mn} = 1, or DAP_{mn} = 1 and CKP_{mn} = 0.

Caution Select the TTL input buffer for the Slp pin and the N-ch open drain output (V_{DD} tolerance (for the 20- to 52-pin products)/EV_{DD} tolerance (for the 64- to 128-pin products)) mode for the SOp pin and SCKp pin by using port input mode register g (PIMg) and port output mode register g (POMg). For V_{IH} and V_{IL}, see the DC characteristics with TTL input buffer selected.

(Remarks are listed on the next page.)

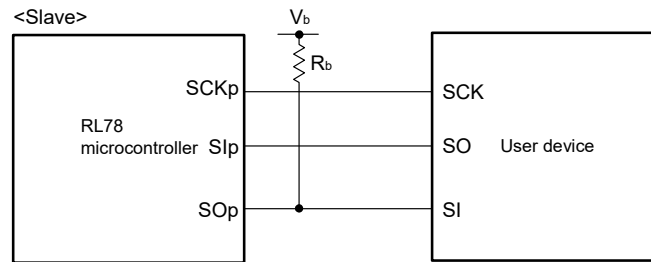
Simplified SPI (CSI) mode connection diagram (during communication at different potential)

- Remarks**
- $R_b[\Omega]$: Communication line (SO_p) pull-up resistance, $C_b[\text{F}]$: Communication line (SO_p) load capacitance, $V_b[\text{V}]$: Communication line voltage
 - p: CSI number (p = 00, 01, 10, 20, 30, 31), m: Unit number, n: Channel number (mn = 00, 01, 02, 10, 12, 13), g: PIM and POM number (g = 0, 1, 4, 5, 8, 14)
 - f_{MCK} : Serial array unit operation clock frequency
(Operation clock to be set by the CKS_{mn} bit of serial mode register mn (SMR_{mn}).
m: Unit number, n: Channel number (mn = 00, 01, 02, 10, 12, 13))
 - CSI01 of 48-, 52-, 64-pin products, and CSI11 and CSI21 cannot communicate at different potential. Use other CSI for communication at different potential.

Simplified SPI (CSI) mode serial transfer timing (slave mode) (during communication at different potential)
(When DAPmn = 0 and CKPmn = 0, or DAPmn = 1 and CKPmn = 1.)

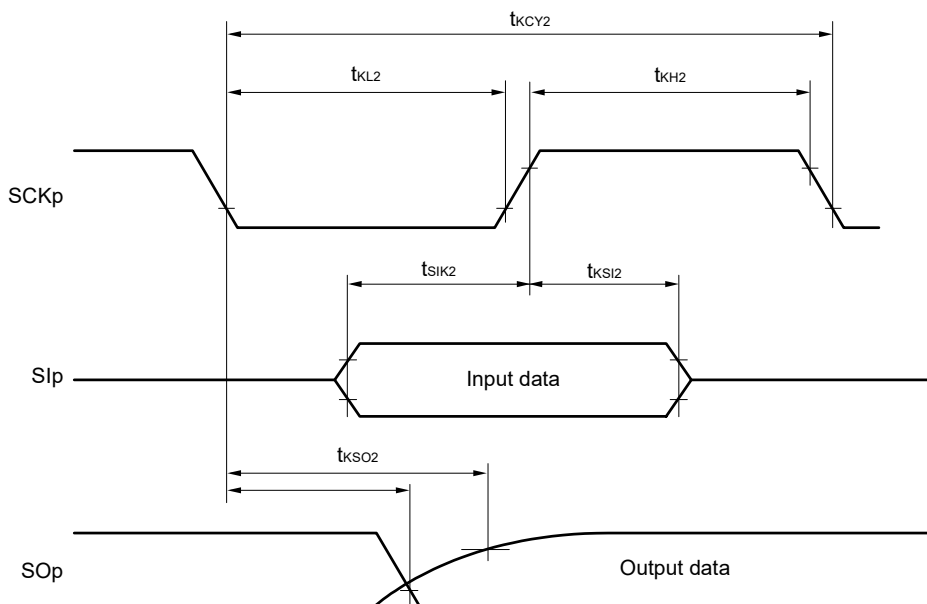

Simplified SPI (CSI) mode serial transfer timing (slave mode) (during communication at different potential)
(When DAPmn = 0 and CKPmn = 1, or DAPmn = 1 and CKPmn = 0.)

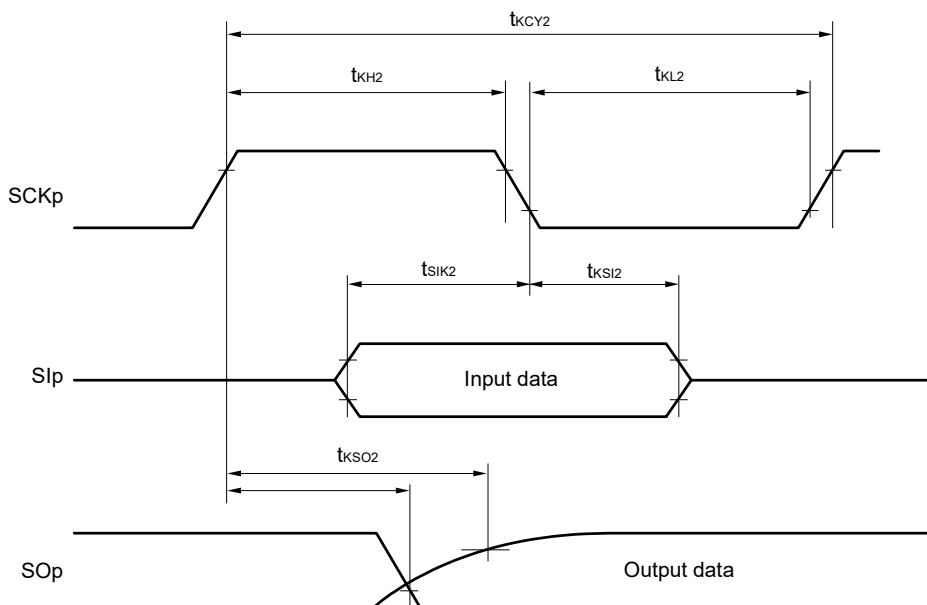

- Remarks**
1. p: CSI number (p = 00, 01, 10, 20, 30, 31), m: Unit number, n: Channel number (mn = 00, 01, 02, 10, 12, 13), g: PIM and POM number (g = 0, 1, 4, 5, 8, 14)
 2. CSI01 of 48-, 52-, 64-pin products, and CSI11 and CSI21 cannot communicate at different potential. Use other CSI for communication at different potential.

(10) Communication at different potential (1.8 V, 2.5 V, 3 V) (simplified I²C mode) (1/2)(T_A = -40 to +85°C, 1.8 V ≤ EV_{DD0} = EV_{DD1} ≤ V_{DD} ≤ 5.5 V, V_{SS} = EV_{SS0} = EV_{SS1} = 0 V)

Parameter	Symbol	Conditions	HS (high-speed main) Mode		LS (low-speed main) Mode		LV (low-voltage main) Mode		Unit
			MIN.	MAX.	MIN.	MAX.	MIN.	MAX.	
SCLr clock frequency	f _{SCL}	4.0 V ≤ EV _{DD0} ≤ 5.5 V, 2.7 V ≤ V _b ≤ 4.0 V, C _b = 50 pF, R _b = 2.7 kΩ		1000 Note 1		300 Note 1		300 Note 1	kHz
		2.7 V ≤ EV _{DD0} < 4.0 V, 2.3 V ≤ V _b ≤ 2.7 V, C _b = 50 pF, R _b = 2.7 kΩ		1000 Note 1		300 Note 1		300 Note 1	kHz
		4.0 V ≤ EV _{DD0} ≤ 5.5 V, 2.7 V ≤ V _b ≤ 4.0 V, C _b = 100 pF, R _b = 2.8 kΩ		400 Note 1		300 Note 1		300 Note 1	kHz
		2.7 V ≤ EV _{DD0} < 4.0 V, 2.3 V ≤ V _b ≤ 2.7 V, C _b = 100 pF, R _b = 2.7 kΩ		400 Note 1		300 Note 1		300 ote 1	kHz
		1.8 V ≤ EV _{DD0} < 3.3 V, 1.6 V ≤ V _b ≤ 2.0 V ^{Note 2} , C _b = 100 pF, R _b = 5.5 kΩ		300 Note 1		300 Note 1		300 Note 1	kHz
Hold time when SCLr = "L"	t _{LOW}	4.0 V ≤ EV _{DD0} ≤ 5.5 V, 2.7 V ≤ V _b ≤ 4.0 V, C _b = 50 pF, R _b = 2.7 kΩ	475		1550		1550		ns
		2.7 V ≤ EV _{DD0} < 4.0 V, 2.3 V ≤ V _b ≤ 2.7 V, C _b = 50 pF, R _b = 2.7 kΩ	475		1550		1550		ns
		4.0 V ≤ EV _{DD0} ≤ 5.5 V, 2.7 V ≤ V _b ≤ 4.0 V, C _b = 100 pF, R _b = 2.8 kΩ	1150		1550		1550		ns
		2.7 V ≤ EV _{DD0} < 4.0 V, 2.3 V ≤ V _b ≤ 2.7 V, C _b = 100 pF, R _b = 2.7 kΩ	1150		1550		1550		ns
		1.8 V ≤ EV _{DD0} < 3.3 V, 1.6 V ≤ V _b ≤ 2.0 V ^{Note 2} , C _b = 100 pF, R _b = 5.5 kΩ	1550		1550		1550		ns
Hold time when SCLr = "H"	t _{HIGH}	4.0 V ≤ EV _{DD0} ≤ 5.5 V, 2.7 V ≤ V _b ≤ 4.0 V, C _b = 50 pF, R _b = 2.7 kΩ	245		610		610		ns
		2.7 V ≤ EV _{DD0} < 4.0 V, 2.3 V ≤ V _b ≤ 2.7 V, C _b = 50 pF, R _b = 2.7 kΩ	200		610		610		ns
		4.0 V ≤ EV _{DD0} ≤ 5.5 V, 2.7 V ≤ V _b ≤ 4.0 V, C _b = 100 pF, R _b = 2.8 kΩ	675		610		610		ns
		2.7 V ≤ EV _{DD0} < 4.0 V, 2.3 V ≤ V _b ≤ 2.7 V, C _b = 100 pF, R _b = 2.7 kΩ	600		610		610		ns
		1.8 V ≤ EV _{DD0} < 3.3 V, 1.6 V ≤ V _b ≤ 2.0 V ^{Note 2} , C _b = 100 pF, R _b = 5.5 kΩ	610		610		610		ns

(10) Communication at different potential (1.8 V, 2.5 V, 3 V) (simplified I²C mode) (2/2)**(T_A = -40 to +85°C, 1.8 V ≤ EV_{DD0} = EV_{DD1} ≤ V_{DD} ≤ 5.5 V, V_{SS} = EV_{SS0} = EV_{SS1} = 0 V)**

Parameter	Symbol	Conditions	HS (high-speed main) Mode		LS (low-speed main) Mode		LV (low-voltage main) Mode		Unit
			MIN.	MAX.	MIN.	MAX.	MIN.	MAX.	
Data setup time (reception)	t _{SU:DAT}	4.0 V ≤ EV _{DD0} ≤ 5.5 V, 2.7 V ≤ V _b ≤ 4.0 V, C _b = 50 pF, R _b = 2.7 kΩ	1/f _{MCK} + 135 ^{Note 3}		1/f _{MCK} + 190 ^{Note 3}		1/f _{MCK} + 190 ^{Note 3}		kHz
		2.7 V ≤ EV _{DD0} < 4.0 V, 2.3 V ≤ V _b ≤ 2.7 V, C _b = 50 pF, R _b = 2.7 kΩ	1/f _{MCK} + 135 ^{Note 3}		1/f _{MCK} + 190 ^{Note 3}		1/f _{MCK} + 190 ^{Note 3}		kHz
		4.0 V ≤ EV _{DD0} ≤ 5.5 V, 2.7 V ≤ V _b ≤ 4.0 V, C _b = 100 pF, R _b = 2.8 kΩ	1/f _{MCK} + 190 ^{Note 3}		1/f _{MCK} + 190 ^{Note 3}		1/f _{MCK} + 190 ^{Note 3}		kHz
		2.7 V ≤ EV _{DD0} < 4.0 V, 2.3 V ≤ V _b ≤ 2.7 V, C _b = 100 pF, R _b = 2.7 kΩ	1/f _{MCK} + 190 ^{Note 3}		1/f _{MCK} + 190 ^{Note 3}		1/f _{MCK} + 190 ^{Note 3}		kHz
		1.8 V ≤ EV _{DD0} < 3.3 V, 1.6 V ≤ V _b ≤ 2.0 V ^{Note 2} , C _b = 100 pF, R _b = 5.5 kΩ	1/f _{MCK} + 190 ^{Note 3}		1/f _{MCK} + 190 ^{Note 3}		1/f _{MCK} + 190 ^{Note 3}		kHz
Data hold time (transmission)	t _{HD:DAT}	4.0 V ≤ EV _{DD0} ≤ 5.5 V, 2.7 V ≤ V _b ≤ 4.0 V, C _b = 50 pF, R _b = 2.7 kΩ	0	305	0	305	0	305	ns
		2.7 V ≤ EV _{DD0} < 4.0 V, 2.3 V ≤ V _b ≤ 2.7 V, C _b = 50 pF, R _b = 2.7 kΩ	0	305	0	305	0	305	ns
		4.0 V ≤ EV _{DD0} ≤ 5.5 V, 2.7 V ≤ V _b ≤ 4.0 V, C _b = 100 pF, R _b = 2.8 kΩ	0	355	0	355	0	355	ns
		2.7 V ≤ EV _{DD0} < 4.0 V, 2.3 V ≤ V _b ≤ 2.7 V, C _b = 100 pF, R _b = 2.7 kΩ	0	355	0	355	0	355	ns
		1.8 V ≤ EV _{DD0} < 3.3 V, 1.6 V ≤ V _b ≤ 2.0 V ^{Note 2} , C _b = 100 pF, R _b = 5.5 kΩ	0	405	0	405	0	405	ns

- Notes**
- The value must also be equal to or less than f_{MCK}/4.
 - Use it with EV_{DD0} ≥ V_b.
 - Set the f_{MCK} value to keep the hold time of SCLr = "L" and SCLr = "H".

Caution Select the TTL input buffer and the N-ch open drain output (V_{DD} tolerance (for the 20- to 52-pin products)/EV_{DD} tolerance (for the 64- to 128-pin products)) mode for the SDAr pin and the N-ch open drain output (V_{DD} tolerance (for the 20- to 52-pin products)/EV_{DD} tolerance (for the 64- to 128-pin products)) mode for the SCLr pin by using port input mode register g (PIMg) and port output mode register g (POMg). For V_{IH} and V_{IL}, see the DC characteristics with TTL input buffer selected.

(Remarks are listed on the next page.)

Simplified I²C mode connection diagram (during communication at different potential)

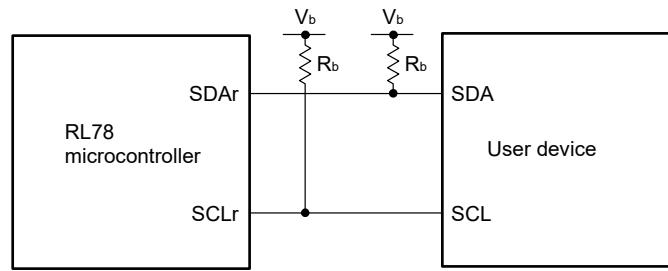

Simplified I²C mode serial transfer timing (during communication at different potential)

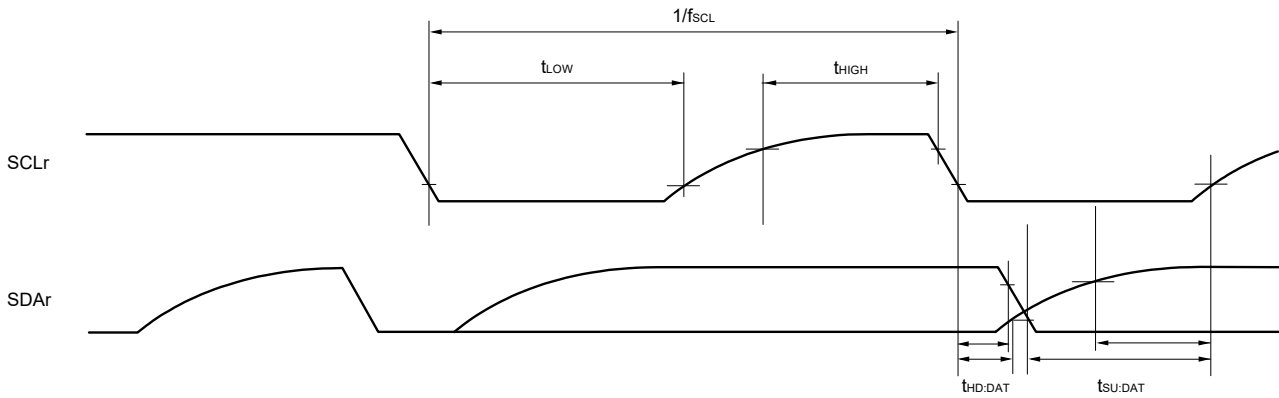

- Remarks**
1. R_b[Ω]: Communication line (SDAr, SCLr) pull-up resistance, C_b[F]: Communication line (SDAr, SCLr) load capacitance, V_b[V]: Communication line voltage
 2. r: IIC number (r = 00, 01, 10, 20, 30, 31), g: PIM, POM number (g = 0, 1, 4, 5, 8, 14)
 3. f_{MCK}: Serial array unit operation clock frequency
(Operation clock to be set by the CKSmn bit of serial mode register mn (SMRmn). m: Unit number, n: Channel number (mn = 00, 01, 02, 10, 12, 13))

29.5.2 Serial interface IICA

(1) I²C standard mode(T_A = -40 to +85°C, 1.6 V ≤ EV_{DD0} = EV_{DD1} ≤ V_{DD} ≤ 5.5 V, V_{SS} = EV_{SS0} = EV_{SS1} = 0 V)

Parameter	Symbol	Conditions	HS (high-speed main) Mode		LS (low-speed main) Mode		LV (low-voltage main) Mode		Unit	
			MIN.	MAX.	MIN.	MAX.	MIN.	MAX.		
SCLA0 clock frequency	f _{SCL}	Standard mode: f _{CLK} ≥ 1 MHz	2.7 V ≤ EV _{DD0} ≤ 5.5 V	0	100	0	100	0	100	kHz
			1.8 V ≤ EV _{DD0} ≤ 5.5 V	0	100	0	100	0	100	kHz
			1.7 V ≤ EV _{DD0} ≤ 5.5 V	0	100	0	100	0	100	kHz
			1.6 V ≤ EV _{DD0} ≤ 5.5 V	-		0	100	0	100	kHz
Setup time of restart condition	t _{SU:STA}	2.7 V ≤ EV _{DD0} ≤ 5.5 V	4.7		4.7		4.7		μs	
		1.8 V ≤ EV _{DD0} ≤ 5.5 V	4.7		4.7		4.7		μs	
		1.7 V ≤ EV _{DD0} ≤ 5.5 V	4.7		4.7		4.7		μs	
		1.6 V ≤ EV _{DD0} ≤ 5.5 V	-		4.7		4.7		μs	
Hold time ^{Note 1}	t _{HD:STA}	2.7 V ≤ EV _{DD0} ≤ 5.5 V	4.0		4.0		4.0		μs	
		1.8 V ≤ EV _{DD0} ≤ 5.5 V	4.0		4.0		4.0		μs	
		1.7 V ≤ EV _{DD0} ≤ 5.5 V	4.0		4.0		4.0		μs	
		1.6 V ≤ EV _{DD0} ≤ 5.5 V	-		4.0		4.0		μs	
Hold time when SCLA0 = "L"	t _{LOW}	2.7 V ≤ EV _{DD0} ≤ 5.5 V	4.7		4.7		4.7		μs	
		1.8 V ≤ EV _{DD0} ≤ 5.5 V	4.7		4.7		4.7		μs	
		1.7 V ≤ EV _{DD0} ≤ 5.5 V	4.7		4.7		4.7		μs	
		1.6 V ≤ EV _{DD0} ≤ 5.5 V	-		4.7		4.7		μs	
Hold time when SCLA0 = "H"	t _{HIGH}	2.7 V ≤ EV _{DD0} ≤ 5.5 V	4.0		4.0		4.0		μs	
		1.8 V ≤ EV _{DD0} ≤ 5.5 V	4.0		4.0		4.0		μs	
		1.7 V ≤ EV _{DD0} ≤ 5.5 V	4.0		4.0		4.0		μs	
		1.6 V ≤ EV _{DD0} ≤ 5.5 V	-		4.0		4.0		μs	
Data setup time (reception)	t _{SU:DAT}	2.7 V ≤ EV _{DD0} ≤ 5.5 V	250		250		250		ns	
		1.8 V ≤ EV _{DD0} ≤ 5.5 V	250		250		250		ns	
		1.7 V ≤ EV _{DD0} ≤ 5.5 V	250		250		250		ns	
		1.6 V ≤ EV _{DD0} ≤ 5.5 V	-		250		250		ns	
Data hold time (transmission) ^{Note 2}	t _{HD:DAT}	2.7 V ≤ EV _{DD0} ≤ 5.5 V	0	3.45	0	3.45	0	3.45	μs	
		1.8 V ≤ EV _{DD0} ≤ 5.5 V	0	3.45	0	3.45	0	3.45	μs	
		1.7 V ≤ EV _{DD0} ≤ 5.5 V	0	3.45	0	3.45	0	3.45	μs	
		1.6 V ≤ EV _{DD0} ≤ 5.5 V	-		0	3.45	0	3.45	μs	
Setup time of stop condition	t _{SU:STO}	2.7 V ≤ EV _{DD0} ≤ 5.5 V	4.0		4.0		4.0		μs	
		1.8 V ≤ EV _{DD0} ≤ 5.5 V	4.0		4.0		4.0		μs	
		1.7 V ≤ EV _{DD0} ≤ 5.5 V	4.0		4.0		4.0		μs	
		1.6 V ≤ EV _{DD0} ≤ 5.5 V	-		4.0		4.0		μs	
Bus-free time	t _{BUF}	2.7 V ≤ EV _{DD0} ≤ 5.5 V	4.7		4.7		4.7		μs	
		1.8 V ≤ EV _{DD0} ≤ 5.5 V	4.7		4.7		4.7		μs	
		1.7 V ≤ EV _{DD0} ≤ 5.5 V	4.7		4.7		4.7		μs	
		1.6 V ≤ EV _{DD0} ≤ 5.5 V	-		4.7		4.7		μs	

(Notes, Caution and Remark are listed on the next page.)

- Notes**
1. The first clock pulse is generated after this period when the start/restart condition is detected.
 2. The maximum value (MAX.) of t_{HD:DAT} is during normal transfer and a clock stretch state is inserted in the ACK (acknowledge) timing.

Caution The values in the above table are applied even when bit 2 (PIOR2) in the peripheral I/O redirection register (PIOR) is 1. At this time, the pin characteristics (I_{OH1}, I_{OL1}, V_{OH1}, V_{OL1}) must satisfy the values in the redirect destination.

Remark The maximum value of C_b (communication line capacitance) and the value of R_b (communication line pull-up resistor) at that time in each mode are as follows.

Standard mode: C_b = 400 pF, R_b = 2.7 kΩ

(2) I²C fast mode(T_A = -40 to +85°C, 1.6 V ≤ EV_{DD0} = EV_{DD1} ≤ V_{DD} ≤ 5.5 V, V_{SS} = EV_{SS0} = EV_{SS1} = 0 V)

Parameter	Symbol	Conditions	HS (high-speed main) Mode		LS (low-speed main) Mode		LV (low-voltage main) Mode		Unit	
			MIN.	MAX.	MIN.	MAX.	MIN.	MAX.		
SCLA0 clock frequency	f _{SCL}	Fast mode: f _{CLK} ≥ 3.5 MHz	2.7 V ≤ EV _{DD0} ≤ 5.5 V	0	400	0	400	0	400	kHz
			1.8 V ≤ EV _{DD0} ≤ 5.5 V	0	400	0	400	0	400	kHz
Setup time of restart condition	t _{SU:STA}	2.7 V ≤ EV _{DD0} ≤ 5.5 V	0.6		0.6		0.6		μs	
		1.8 V ≤ EV _{DD0} ≤ 5.5 V	0.6		0.6		0.6		μs	
Hold time ^{Note 1}	t _{HD:STA}	2.7 V ≤ EV _{DD0} ≤ 5.5 V	0.6		0.6		0.6		μs	
		1.8 V ≤ EV _{DD0} ≤ 5.5 V	0.6		0.6		0.6		μs	
Hold time when SCLA0 = "L"	t _{LOW}	2.7 V ≤ EV _{DD0} ≤ 5.5 V	1.3		1.3		1.3		μs	
		1.8 V ≤ EV _{DD0} ≤ 5.5 V	1.3		1.3		1.3		μs	
Hold time when SCLA0 = "H"	t _{HIGH}	2.7 V ≤ EV _{DD0} ≤ 5.5 V	0.6		0.6		0.6		μs	
		1.8 V ≤ EV _{DD0} ≤ 5.5 V	0.6		0.6		0.6		μs	
Data setup time (reception)	t _{SU:DAT}	2.7 V ≤ EV _{DD0} ≤ 5.5 V	100		100		100		μs	
		1.8 V ≤ EV _{DD0} ≤ 5.5 V	100		100		100		μs	
Data hold time (transmission) ^{Note 2}	t _{HD:DAT}	2.7 V ≤ EV _{DD0} ≤ 5.5 V	0	0.9	0	0.9	0	0.9	μs	
		1.8 V ≤ EV _{DD0} ≤ 5.5 V	0	0.9	0	0.9	0	0.9	μs	
Setup time of stop condition	t _{SU:STO}	2.7 V ≤ EV _{DD0} ≤ 5.5 V	0.6		0.6		0.6		μs	
		1.8 V ≤ EV _{DD0} ≤ 5.5 V	0.6		0.6		0.6		μs	
Bus-free time	t _{BUF}	2.7 V ≤ EV _{DD0} ≤ 5.5 V	1.3		1.3		1.3		μs	
		1.8 V ≤ EV _{DD0} ≤ 5.5 V	1.3		1.3		1.3		μs	

- Notes**
- The first clock pulse is generated after this period when the start/restart condition is detected.
 - The maximum value (MAX.) of t_{HD:DAT} is during normal transfer and a clock stretch state is inserted in the ACK (acknowledge) timing.

Caution The values in the above table are applied even when bit 2 (PIOR2) in the peripheral I/O redirection register (PIOR) is 1. At this time, the pin characteristics (I_{OH1}, I_{OL1}, V_{OH1}, V_{OL1}) must satisfy the values in the redirect destination.

Remark The maximum value of C_b (communication line capacitance) and the value of R_b (communication line pull-up resistor) at that time in each mode are as follows.

Fast mode: C_b = 320 pF, R_b = 1.1 kΩ

(3) I²C fast mode plus

(T_A = -40 to +85°C, 1.6 V ≤ EV_{DD0} = EV_{DD1} ≤ V_{DD} ≤ 5.5 V, V_{SS} = EV_{SS0} = EV_{SS1} = 0 V)

Parameter	Symbol	Conditions	HS (high-speed main) Mode		LS (low-speed main) Mode		LV (low-voltage main) Mode		Unit
			MIN.	MAX.	MIN.	MAX.	MIN.	MAX.	
SCLA0 clock frequency	f _{SCL}	Fast mode plus: f _{CLK} ≥ 10 MHz 2.7 V ≤ EV _{DD0} ≤ 5.5 V	0	1000	–	–	–	–	kHz
Setup time of restart condition	t _{SU:STA}	2.7 V ≤ EV _{DD0} ≤ 5.5 V	0.26		–	–	–	–	μs
Hold time ^{Note 1}	t _{HD:STA}	2.7 V ≤ EV _{DD0} ≤ 5.5 V	0.26		–	–	–	–	μs
Hold time when SCLA0 = “L”	t _{LOW}	2.7 V ≤ EV _{DD0} ≤ 5.5 V	0.5		–	–	–	–	μs
Hold time when SCLA0 = “H”	t _{HIGH}	2.7 V ≤ EV _{DD0} ≤ 5.5 V	0.26		–	–	–	–	μs
Data setup time (reception)	t _{SU:DAT}	2.7 V ≤ EV _{DD0} ≤ 5.5 V	50		–	–	–	–	μs
Data hold time (transmission) ^{Note 2}	t _{HD:DAT}	2.7 V ≤ EV _{DD0} ≤ 5.5 V	0	0.45	–	–	–	–	μs
Setup time of stop condition	t _{SU:STO}	2.7 V ≤ EV _{DD0} ≤ 5.5 V	0.26		–	–	–	–	μs
Bus-free time	t _{BUF}	2.7 V ≤ EV _{DD0} ≤ 5.5 V	0.5		–	–	–	–	μs

- Notes**
- The first clock pulse is generated after this period when the start/restart condition is detected.
 - The maximum value (MAX.) of t_{HD:DAT} is during normal transfer and a clock stretch state is inserted in the ACK (acknowledge) timing.

Caution The values in the above table are applied even when bit 2 (PIOR2) in the peripheral I/O redirection register (PIOR) is 1. At this time, the pin characteristics (I_{OH1}, I_{OL1}, V_{OH1}, V_{OL1}) must satisfy the values in the redirect destination.

Remark The maximum value of C_b (communication line capacitance) and the value of R_b (communication line pull-up resistor) at that time in each mode are as follows.

Fast mode plus: C_b = 120 pF, R_b = 1.1 kΩ

I²C serial transfer timing

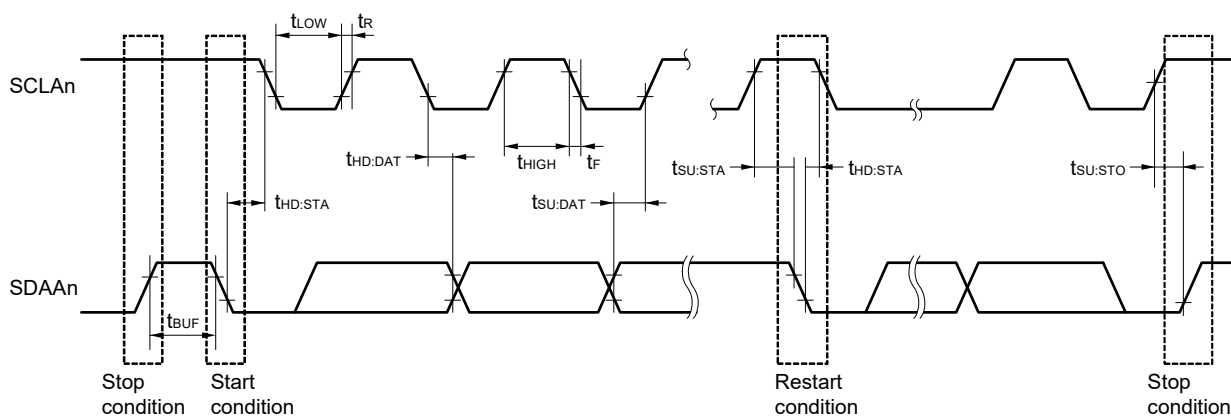

Remark n = 0, 1

29.6 Analog Characteristics

29.6.1 A/D converter characteristics

Classification of A/D converter characteristics

Input channel	Reference Voltage		
	Reference voltage (+) = AV _{REFP} Reference voltage (-) = AV _{REFM}	Reference voltage (+) = V _{DD} Reference voltage (-) = V _{SS}	Reference voltage (+) = V _{BGR} Reference voltage (-) = AV _{REFM}
ANI0 to ANI14	Refer to 29.6.1 (1) .	Refer to 29.6.1 (3) .	Refer to 29.6.1 (4) .
ANI16 to ANI26	Refer to 29.6.1 (2) .		
Internal reference voltage Temperature sensor output voltage	Refer to 29.6.1 (1) .		—

(1) When reference voltage (+) = AV_{REFP}/ANI0 (ADREFP1 = 0, ADREFP0 = 1), reference voltage (-) = AV_{REFM}/ANI1 (ADREFM = 1), target pin : ANI2 to ANI14, internal reference voltage, and temperature sensor output voltage

(T_A = -40 to +85°C, 1.6 V ≤ AV_{REFP} ≤ V_{DD} ≤ 5.5 V, V_{SS} = 0 V, Reference voltage (+) = AV_{REFP}, Reference voltage (-) = AV_{REFM} = 0 V)

Parameter	Symbol	Conditions		MIN.	TYP.	MAX.	Unit
Resolution	RES			8		10	bit
Overall error ^{Note 1}	AINL	10-bit resolution AV _{REFP} = V _{DD} ^{Note 3}	1.8 V ≤ AV _{REFP} ≤ 5.5 V		1.2	±3.5	LSB
			1.6 V ≤ AV _{REFP} ≤ 5.5 V ^{Note 4}		1.2	±7.0	LSB
Conversion time	t _{CONV}	10-bit resolution Target pin: ANI2 to ANI14	3.6 V ≤ V _{DD} ≤ 5.5 V	2.125		39	μs
			2.7 V ≤ V _{DD} ≤ 5.5 V	3.1875		39	μs
			1.8 V ≤ V _{DD} ≤ 5.5 V	17		39	μs
			1.6 V ≤ V _{DD} ≤ 5.5 V	57		95	μs
		10-bit resolution Target pin: Internal reference voltage, and temperature sensor output voltage (HS (high-speed main) mode)	3.6 V ≤ V _{DD} ≤ 5.5 V	2.375		39	μs
			2.4 V ≤ V _{DD} ≤ 5.5 V	17		39	μs
Zero-scale error ^{Notes 1, 2}	E _{ZS}	10-bit resolution AV _{REFP} = V _{DD} ^{Note 3}	1.8 V ≤ AV _{REFP} ≤ 5.5 V			±0.25	%FSR
			1.6 V ≤ AV _{REFP} ≤ 5.5 V ^{Note 4}			±0.50	%FSR
Full-scale error ^{Notes 1, 2}	E _{FS}	10-bit resolution AV _{REFP} = V _{DD} ^{Note 3}	1.8 V ≤ AV _{REFP} ≤ 5.5 V			±0.25	%FSR
			1.6 V ≤ AV _{REFP} ≤ 5.5 V ^{Note 4}			±0.50	%FSR
Integral linearity error ^{Note 1}	ILE	10-bit resolution AV _{REFP} = V _{DD} ^{Note 3}	1.8 V ≤ AV _{REFP} ≤ 5.5 V			±2.5	LSB
			1.6 V ≤ AV _{REFP} ≤ 5.5 V ^{Note 4}			±5.0	LSB
Differential linearity error ^{Note 1}	DLE	10-bit resolution AV _{REFP} = V _{DD} ^{Note 3}	1.8 V ≤ AV _{REFP} ≤ 5.5 V			±1.5	LSB
			1.6 V ≤ AV _{REFP} ≤ 5.5 V ^{Note 4}			±2.0	LSB
Analog input voltage	V _{AIN}	ANI2 to ANI14		0		AV _{REFP}	V
		Internal reference voltage (2.4 V ≤ V _{DD} ≤ 5.5 V, HS (high-speed main) mode)				V _{BGR} ^{Note 5}	V
		Temperature sensor output voltage (2.4 V ≤ V _{DD} ≤ 5.5 V, HS (high-speed main) mode)				V _{TMPS25} ^{Note 5}	V

(Notes are listed on the next page.)

- Notes**
1. Excludes quantization error ($\pm 1/2$ LSB).
 2. This value is indicated as a ratio (%FSR) to the full-scale value.
 3. When $AV_{REFP} < V_{DD}$, the MAX. values are as follows.
Overall error: Add ± 1.0 LSB to the MAX. value when $AV_{REFP} = V_{DD}$.
Zero-scale error/Full-scale error: Add $\pm 0.05\%$ FSR to the MAX. value when $AV_{REFP} = V_{DD}$.
Integral linearity error/ Differential linearity error: Add ± 0.5 LSB to the MAX. value when $AV_{REFP} = V_{DD}$.
 4. Values when the conversion time is set to $57 \mu\text{s}$ (min.) and $95 \mu\text{s}$ (max.).
 5. Refer to **29.6.2 Temperature sensor/internal reference voltage characteristics**.

(2) When reference voltage (+) = AV_{REFP}/ANI0 (ADREFP1 = 0, ADREFP0 = 1), reference voltage (-) = AV_{REFM}/ANI1 (ADREFM = 1), target pin : ANI16 to ANI26

(T_A = -40 to +85°C, 1.6 V ≤ EV_{DD0} = EV_{DD1} ≤ V_{DD} ≤ 5.5 V, 1.6 V ≤ AV_{REFP} ≤ V_{DD} ≤ 5.5 V, V_{SS} = EV_{SS0} = EV_{SS1} = 0 V, Reference voltage (+) = AV_{REFP}, Reference voltage (-) = AV_{REFM} = 0 V)

Parameter	Symbol	Conditions	MIN.	TYP.	MAX.	Unit	
Resolution	RES		8		10	bit	
Overall error ^{Note 1}	AINL	10-bit resolution EV _{DD0} = AV _{REFP} = V _{DD} ^{Notes 3, 4}	1.8 V ≤ AV _{REFP} ≤ 5.5 V		1.2	±5.0	LSB
			1.6 V ≤ AV _{REFP} ≤ 5.5 V ^{Note 5}		1.2	±8.5	LSB
Conversion time	t _{CONV}	10-bit resolution Target ANI pin : ANI16 to ANI26	3.6 V ≤ V _{DD} ≤ 5.5 V	2.125		39	μs
			2.7 V ≤ V _{DD} ≤ 5.5 V	3.1875		39	μs
			1.8 V ≤ V _{DD} ≤ 5.5 V	17		39	μs
			1.6 V ≤ V _{DD} ≤ 5.5 V	57		95	μs
Zero-scale error ^{Notes 1, 2}	E _{ZS}	10-bit resolution EV _{DD0} = AV _{REFP} = V _{DD} ^{Notes 3, 4}	1.8 V ≤ AV _{REFP} ≤ 5.5 V			±0.35	%FSR
			1.6 V ≤ AV _{REFP} ≤ 5.5 V ^{Note 5}			±0.60	%FSR
Full-scale error ^{Notes 1, 2}	E _{FS}	10-bit resolution EV _{DD0} = AV _{REFP} = V _{DD} ^{Notes 3, 4}	1.8 V ≤ AV _{REFP} ≤ 5.5 V			±0.35	%FSR
			1.6 V ≤ AV _{REFP} ≤ 5.5 V ^{Note 5}			±0.60	%FSR
Integral linearity error ^{Note 1}	ILE	10-bit resolution EV _{DD0} = AV _{REFP} = V _{DD} ^{Notes 3, 4}	1.8 V ≤ AV _{REFP} ≤ 5.5 V			±3.5	LSB
			1.6 V ≤ AV _{REFP} ≤ 5.5 V ^{Note 5}			±6.0	LSB
Differential linearity error ^{Note 1}	DLE	10-bit resolution EV _{DD0} = AV _{REFP} = V _{DD} ^{Notes 3, 4}	1.8 V ≤ AV _{REFP} ≤ 5.5 V			±2.0	LSB
			1.6 V ≤ AV _{REFP} ≤ 5.5 V ^{Note 5}			±2.5	LSB
Analog input voltage	V _{AIN}	ANI16 to ANI26	0		AV _{REFP} and EV _{DD0}	V	

Notes 1. Excludes quantization error (±1/2 LSB).

2. This value is indicated as a ratio (%FSR) to the full-scale value.

3. When AV_{REFP} < V_{DD}, the MAX. values are as follows.

Overall error: Add ±1.0 LSB to the MAX. value when AV_{REFP} = V_{DD}.

Zero-scale error/Full-scale error: Add ±0.05%FSR to the MAX. value when AV_{REFP} = V_{DD}.

Integral linearity error/ Differential linearity error: Add ±0.5 LSB to the MAX. value when AV_{REFP} = V_{DD}.

4. When AV_{REFP} < EV_{DD0} ≤ V_{DD}, the MAX. values are as follows.

Overall error: Add ±4.0 LSB to the MAX. value when AV_{REFP} = V_{DD}.

Zero-scale error/Full-scale error: Add ±0.20%FSR to the MAX. value when AV_{REFP} = V_{DD}.

Integral linearity error/ Differential linearity error: Add ±2.0 LSB to the MAX. value when AV_{REFP} = V_{DD}.

5. When the conversion time is set to 57 μs (min.) and 95 μs (max.).

(3) When reference voltage (+) = V_{DD} (ADREFP1 = 0, ADREFP0 = 0), reference voltage (-) = V_{SS} (ADREFM = 0), target pin : ANI0 to ANI14, ANI16 to ANI26, internal reference voltage, and temperature sensor output voltage

(T_A = -40 to +85°C, 1.6 V ≤ EV_{DD0} = EV_{DD1} ≤ V_{DD} ≤ 5.5 V, V_{SS} = EV_{SS0} = EV_{SS1} = 0 V, Reference voltage (+) = V_{DD}, Reference voltage (-) = V_{SS})

Parameter	Symbol	Conditions	MIN.	TYP.	MAX.	Unit	
Resolution	RES		8		10	bit	
Overall error ^{Note 1}	AINL	10-bit resolution	1.8 V ≤ V _{DD} ≤ 5.5 V		1.2	±7.0	LSB
			1.6 V ≤ V _{DD} ≤ 5.5 V ^{Note 3}		1.2	±10.5	LSB
Conversion time	t _{CONV}	10-bit resolution Target pin: ANI0 to ANI14, ANI16 to ANI26	3.6 V ≤ V _{DD} ≤ 5.5 V	2.125		39	μs
			2.7 V ≤ V _{DD} ≤ 5.5 V	3.1875		39	μs
			1.8 V ≤ V _{DD} ≤ 5.5 V	17		39	μs
			1.6 V ≤ V _{DD} ≤ 5.5 V	57		95	μs
Conversion time	t _{CONV}	10-bit resolution Target pin: Internal reference voltage, and temperature sensor output voltage (HS (high-speed main) mode)	3.6 V ≤ V _{DD} ≤ 5.5 V	2.375		39	μs
			2.7 V ≤ V _{DD} ≤ 5.5 V	3.5625		39	μs
			2.4 V ≤ V _{DD} ≤ 5.5 V	17		39	μs
Zero-scale error ^{Notes 1, 2}	E _{ZS}	10-bit resolution	1.8 V ≤ V _{DD} ≤ 5.5 V			±0.60	%FSR
			1.6 V ≤ V _{DD} ≤ 5.5 V ^{Note 3}			±0.85	%FSR
Full-scale error ^{Notes 1, 2}	E _{FS}	10-bit resolution	1.8 V ≤ V _{DD} ≤ 5.5 V			±0.60	%FSR
			1.6 V ≤ V _{DD} ≤ 5.5 V ^{Note 3}			±0.85	%FSR
Integral linearity error ^{Note 1}	ILE	10-bit resolution	1.8 V ≤ V _{DD} ≤ 5.5 V			±4.0	LSB
			1.6 V ≤ V _{DD} ≤ 5.5 V ^{Note 3}			±6.5	LSB
Differential linearity error ^{Note 1}	DLE	10-bit resolution	1.8 V ≤ V _{DD} ≤ 5.5 V			±2.0	LSB
			1.6 V ≤ V _{DD} ≤ 5.5 V ^{Note 3}			±2.5	LSB
Analog input voltage	V _{AIN}	ANI0 to ANI14	0		V _{DD}	V	
		ANI16 to ANI26	0		EV _{DD0}	V	
		Internal reference voltage (2.4 V ≤ V _{DD} ≤ 5.5 V, HS (high-speed main) mode)	V _{BGR} ^{Note 4}			V	
		Temperature sensor output voltage (2.4 V ≤ V _{DD} ≤ 5.5 V, HS (high-speed main) mode)	V _{TMPS25} ^{Note 4}			V	

Notes 1. Excludes quantization error (±1/2 LSB).

2. This value is indicated as a ratio (%FSR) to the full-scale value.

3. When the conversion time is set to 57 μs (min.) and 95 μs (max.).

4. Refer to **29.6.2 Temperature sensor/internal reference voltage characteristics**.

(4) When reference voltage (+) = Internal reference voltage (ADREFP1 = 1, ADREFP0 = 0), reference voltage (-) = AV_{REFM}/ANI1 (ADREFM = 1), target pin : ANI0, ANI2 to ANI14, ANI16 to ANI26

(T_A = -40 to +85°C, 2.4 V ≤ V_{DD} ≤ 5.5 V, 1.6 V ≤ EV_{DD0} = EV_{DD1} ≤ V_{DD}, V_{SS} = EV_{SS0} = EV_{SS1} = 0 V, Reference voltage (+) = V_{BGR}^{Note 3}, Reference voltage (-) = AV_{REFM} = 0 V^{Note 4}, HS (high-speed main) mode)

Parameter	Symbol	Conditions		MIN.	TYP.	MAX.	Unit
Resolution	RES			8			bit
Conversion time	t _{CONV}	8-bit resolution	2.4 V ≤ V _{DD} ≤ 5.5 V	17		39	μs
Zero-scale error ^{Notes 1, 2}	E _{zs}	8-bit resolution	2.4 V ≤ V _{DD} ≤ 5.5 V			±0.60	%FSR
Integral linearity error ^{Note 1}	ILE	8-bit resolution	2.4 V ≤ V _{DD} ≤ 5.5 V			±2.0	LSB
Differential linearity error ^{Note 1}	DLE	8-bit resolution	2.4 V ≤ V _{DD} ≤ 5.5 V			±1.0	LSB
Analog input voltage	V _{AIN}			0		V _{BGR} ^{Note 3}	V

Notes 1. Excludes quantization error (±1/2 LSB).

2. This value is indicated as a ratio (%FSR) to the full-scale value.

3. Refer to **29.6.2 Temperature sensor/internal reference voltage characteristics**.

4. When reference voltage (-) = V_{SS}, the MAX. values are as follows.

Zero-scale error: Add ±0.35%FSR to the MAX. value when reference voltage (-) = AV_{REFM}.

Integral linearity error: Add ±0.5 LSB to the MAX. value when reference voltage (-) = AV_{REFM}.

Differential linearity error: Add ±0.2 LSB to the MAX. value when reference voltage (-) = AV_{REFM}.

29.6.2 Temperature sensor/internal reference voltage characteristics

($T_A = -40$ to $+85^\circ\text{C}$, $2.4\text{ V} \leq V_{DD} \leq 5.5\text{ V}$, $V_{SS} = 0\text{ V}$, HS (high-speed main) mode)

Parameter	Symbol	Conditions	MIN.	TYP.	MAX.	Unit
Temperature sensor output voltage	V_{TMS25}	Setting ADS register = 80H, $T_A = +25^\circ\text{C}$		1.05		V
Internal reference voltage	V_{BGR}	Setting ADS register = 81H	1.38	1.45	1.5	V
Temperature coefficient	F_{VTMS}	Temperature sensor that depends on the temperature		-3.6		mV/ $^\circ\text{C}$
Operation stabilization wait time	t_{AMP}		5			μs

29.6.3 POR circuit characteristics

($T_A = -40$ to $+85^\circ\text{C}$, $V_{SS} = 0\text{ V}$)

Parameter	Symbol	Conditions	MIN.	TYP.	MAX.	Unit
Detection voltage	V_{POR}	The power supply voltage is rising.	1.47	1.51	1.55	V
	V_{PDR}	The power supply voltage is falling.	1.46	1.50	1.54	V
Minimum pulse width ^{Note}	T_{PW}		300			μs

Note Minimum time required for a POR reset when V_{DD} exceeds below V_{PDR} . This is also the minimum time required for a POR reset from when V_{DD} exceeds below 0.7 V to when V_{DD} exceeds V_{POR} while STOP mode is entered or the main system clock is stopped through setting bit 0 (HIOSTOP) and bit 7 (MSTOP) in the clock operation status control register (CSC).

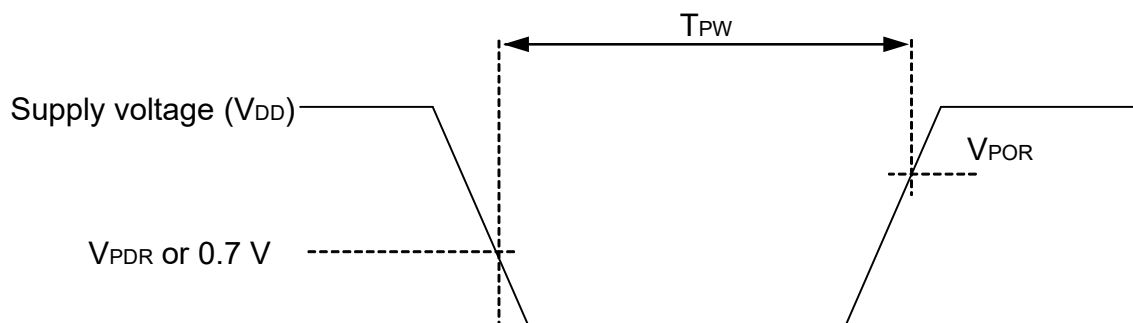

29.6.4 LVD circuit characteristics

LVD Detection Voltage of Reset Mode and Interrupt Mode

(T_A = -40 to +85°C, V_{PDR} ≤ V_{DD} ≤ 5.5 V, V_{SS} = 0 V)

Parameter	Symbol	Conditions	MIN.	TYP.	MAX.	Unit
Detection voltage	V _{LVD0}	The power supply voltage is rising.	3.98	4.06	4.14	V
		The power supply voltage is falling.	3.90	3.98	4.06	V
	V _{LVD1}	The power supply voltage is rising.	3.68	3.75	3.82	V
		The power supply voltage is falling.	3.60	3.67	3.74	V
	V _{LVD2}	The power supply voltage is rising.	3.07	3.13	3.19	V
		The power supply voltage is falling.	3.00	3.06	3.12	V
	V _{LVD3}	The power supply voltage is rising.	2.96	3.02	3.08	V
		The power supply voltage is falling.	2.90	2.96	3.02	V
	V _{LVD4}	The power supply voltage is rising.	2.86	2.92	2.97	V
		The power supply voltage is falling.	2.80	2.86	2.91	V
	V _{LVD5}	The power supply voltage is rising.	2.76	2.81	2.87	V
		The power supply voltage is falling.	2.70	2.75	2.81	V
	V _{LVD6}	The power supply voltage is rising.	2.66	2.71	2.76	V
		The power supply voltage is falling.	2.60	2.65	2.70	V
	V _{LVD7}	The power supply voltage is rising.	2.56	2.61	2.66	V
		The power supply voltage is falling.	2.50	2.55	2.60	V
	V _{LVD8}	The power supply voltage is rising.	2.45	2.50	2.55	V
		The power supply voltage is falling.	2.40	2.45	2.50	V
	V _{LVD9}	The power supply voltage is rising.	2.05	2.09	2.13	V
		The power supply voltage is falling.	2.00	2.04	2.08	V
	V _{LVD10}	The power supply voltage is rising.	1.94	1.98	2.02	V
		The power supply voltage is falling.	1.90	1.94	1.98	V
	V _{LVD11}	The power supply voltage is rising.	1.84	1.88	1.91	V
		The power supply voltage is falling.	1.80	1.84	1.87	V
	V _{LVD12}	The power supply voltage is rising.	1.74	1.77	1.81	V
		The power supply voltage is falling.	1.70	1.73	1.77	V
V _{LVD13}	The power supply voltage is rising.	1.64	1.67	1.70	V	
	The power supply voltage is falling.	1.60	1.63	1.66	V	
Minimum pulse width	t _{LW}		300			μs
Detection delay time					300	μs

LVD Detection Voltage of Interrupt & Reset Mode(T_A = -40 to +85°C, V_{PDR} ≤ V_{DD} ≤ 5.5 V, V_{SS} = 0 V)

Parameter	Symbol	Conditions	MIN.	TYP.	MAX.	Unit	
Interrupt and reset mode	VLVDA0	V _{POC2} , V _{POC1} , V _{POC0} = 0, 0, 0, falling reset voltage	1.60	1.63	1.66	V	
	VLVDA1	LVIS1, LVIS0 = 1, 0	Rising release reset voltage	1.74	1.77	1.81	V
			Falling interrupt voltage	1.70	1.73	1.77	V
	VLVDA2	LVIS1, LVIS0 = 0, 1	Rising release reset voltage	1.84	1.88	1.91	V
			Falling interrupt voltage	1.80	1.84	1.87	V
	VLVDA3	LVIS1, LVIS0 = 0, 0	Rising release reset voltage	2.86	2.92	2.97	V
			Falling interrupt voltage	2.80	2.86	2.91	V
	VLVDB0	V _{POC2} , V _{POC1} , V _{POC0} = 0, 0, 1, falling reset voltage	1.80	1.84	1.87	V	
	VLVDB1	LVIS1, LVIS0 = 1, 0	Rising release reset voltage	1.94	1.98	2.02	V
			Falling interrupt voltage	1.90	1.94	1.98	V
	VLVDB2	LVIS1, LVIS0 = 0, 1	Rising release reset voltage	2.05	2.09	2.13	V
			Falling interrupt voltage	2.00	2.04	2.08	V
	VLVDB3	LVIS1, LVIS0 = 0, 0	Rising release reset voltage	3.07	3.13	3.19	V
			Falling interrupt voltage	3.00	3.06	3.12	V
	VLVDC0	V _{POC2} , V _{POC1} , V _{POC0} = 0, 1, 0, falling reset voltage	2.40	2.45	2.50	V	
	VLVDC1	LVIS1, LVIS0 = 1, 0	Rising release reset voltage	2.56	2.61	2.66	V
			Falling interrupt voltage	2.50	2.55	2.60	V
	VLVDC2	LVIS1, LVIS0 = 0, 1	Rising release reset voltage	2.66	2.71	2.76	V
			Falling interrupt voltage	2.60	2.65	2.70	V
	VLVDC3	LVIS1, LVIS0 = 0, 0	Rising release reset voltage	3.68	3.75	3.82	V
			Falling interrupt voltage	3.60	3.67	3.74	V
	VLVDD0	V _{POC2} , V _{POC1} , V _{POC0} = 0, 1, 1, falling reset voltage	2.70	2.75	2.81	V	
	VLVDD1	LVIS1, LVIS0 = 1, 0	Rising release reset voltage	2.86	2.92	2.97	V
			Falling interrupt voltage	2.80	2.86	2.91	V
VLVDD2	LVIS1, LVIS0 = 0, 1	Rising release reset voltage	2.96	3.02	3.08	V	
		Falling interrupt voltage	2.90	2.96	3.02	V	
VLVDD3	LVIS1, LVIS0 = 0, 0	Rising release reset voltage	3.98	4.06	4.14	V	
		Falling interrupt voltage	3.90	3.98	4.06	V	

29.6.5 Power supply voltage rising slope characteristics(T_A = -40 to +85°C, V_{SS} = 0 V)

Parameter	Symbol	Conditions	MIN.	TYP.	MAX.	Unit
Power supply voltage rising slope	S _{VDD}				54	V/ms

Caution Make sure to keep the internal reset state by the LVD circuit or an external reset until V_{DD} reaches the operating voltage range shown in 29.4 AC Characteristics.

29.7 RAM Data Retention Characteristics

(T_A = -40 to +85°C, V_{SS} = 0 V)

Parameter	Symbol	Conditions	MIN.	TYP.	MAX.	Unit
Data retention supply voltage	V _{DDDR}		1.46 ^{Note}		5.5	V

Note This depends on the POR detection voltage. For a falling voltage, data in RAM are retained until the voltage reaches the level that triggers a POR reset but not once it reaches the level at which a POR reset is generated.

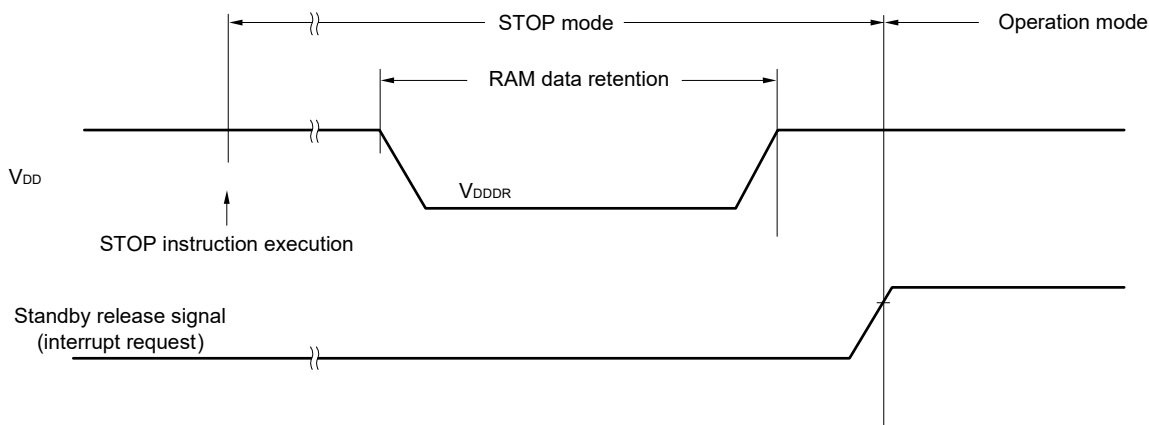

29.8 Flash Memory Programming Characteristics

(T_A = -40 to +85°C, 1.8 V ≤ V_{DD} ≤ 5.5 V, V_{SS} = 0 V)

Parameter	Symbol	Conditions	MIN.	TYP.	MAX.	Unit
CPU/peripheral hardware clock frequency	f _{CLK}	1.8 V ≤ V _{DD} ≤ 5.5 V	1		32	MHz
Number of code flash rewrites <small>Notes 1, 2, 3</small>	C _{enwr}	Retained for 20 years T _A = 85°C	1,000			Times
Number of data flash rewrites <small>Notes 1, 2, 3</small>		Retained for 1 years T _A = 25°C		1,000,000		
		Retained for 5 years T _A = 85°C	100,000			
		Retained for 20 years T _A = 85°C	10,000			

- Notes**
- 1 erase + 1 write after the erase is regarded as 1 rewrite.
The retaining years are until next rewrite after the rewrite.
 2. When using flash memory programmer and Renesas Electronics self programming library
 3. These are the characteristics of the flash memory and the results obtained from reliability testing by Renesas Electronics Corporation.

29.9 Dedicated Flash Memory Programmer Communication (UART)

(T_A = -40 to +85°C, 1.8 V ≤ EV_{DD0} = EV_{DD1} ≤ V_{DD} ≤ 5.5 V, V_{SS} = EV_{SS0} = EV_{SS1} = 0 V)

Parameter	Symbol	Conditions	MIN.	TYP.	MAX.	Unit
Transfer rate		During serial programming	115,200		1,000,000	bps

29.10 Timing of Entry to Flash Memory Programming Modes

(T_A = -40 to +85°C, 1.8 V ≤ EV_{DD0} = EV_{DD1} ≤ V_{DD} ≤ 5.5 V, V_{SS} = EV_{SS0} = EV_{SS1} = 0 V)

Parameter	Symbol	Conditions	MIN.	TYP.	MAX.	Unit
Time to complete the communication for the initial setting after the external reset is released	t _{SUINIT}	POR and LVD reset must be released before the external reset is released.			100	ms
Time to release the external reset after the TOOL0 pin is set to the low level	t _{SU}	POR and LVD reset must be released before the external reset is released.	10			μs
Time to hold the TOOL0 pin at the low level after the external reset is released (excluding the processing time of the firmware to control the flash memory)	t _{HD}	POR and LVD reset must be released before the external reset is released.	1			ms

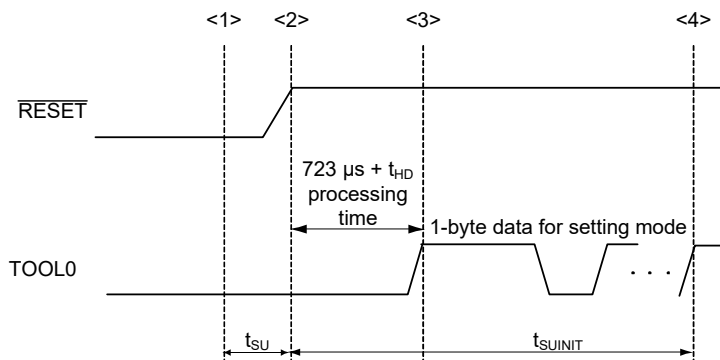

- <1> The low level is input to the TOOL0 pin.
- <2> The external reset is released (POR and LVD reset must be released before the external reset is released.).
- <3> The TOOL0 pin is set to the high level.
- <4> Setting of the flash memory programming mode by UART reception and complete the baud rate setting.

Remark t_{SUINIT}: Communication for the initial setting must be completed within 100 ms after the external reset is released during this period.

t_{SU}: Time to release the external reset after the TOOL0 pin is set to the low level

t_{HD}: Time to hold the TOOL0 pin at the low level after the external reset is released (excluding the processing time of the firmware to control the flash memory)

CHAPTER 30 ELECTRICAL SPECIFICATIONS (G: INDUSTRIAL APPLICATIONS $T_A = -40$ to $+105^\circ\text{C}$)

This chapter describes the following electrical specifications.

Target products G: Industrial applications $T_A = -40$ to $+105^\circ\text{C}$
 R5F100xxGxx

- Cautions**
1. The RL78 microcontrollers have an on-chip debug function, which is provided for development and evaluation. Do not use the on-chip debug function in products designated for mass production, because the guaranteed number of rewritable times of the flash memory may be exceeded when this function is used, and product reliability therefore cannot be guaranteed. Renesas Electronics is not liable for problems occurring when the on-chip debug function is used.
 2. With products not provided with an EV_{DD0} , EV_{DD1} , EV_{SS0} , or EV_{SS1} pin, replace EV_{DD0} and EV_{DD1} with V_{DD} , or replace EV_{SS0} and EV_{SS1} with V_{SS} .
 3. The pins mounted depend on the product. Refer to 2.1 Port Function to 2.2.1 Functions for each product.
 4. Please contact Renesas Electronics sales office for derating of operation under $T_A = +85^\circ\text{C}$ to $+105^\circ\text{C}$. Derating is the systematic reduction of load for the sake of improved reliability.

Remark When RL78/G13 is used in the range of $T_A = -40$ to $+85^\circ\text{C}$, see **CHAPTER 29 ELECTRICAL SPECIFICATIONS ($T_A = -40$ to $+85^\circ\text{C}$)**.

There are following differences between the products "G: Industrial applications ($T_A = -40$ to $+105^\circ\text{C}$)" and the products "A: Consumer applications, and D: Industrial applications".

Parameter	Application	
	A: Consumer applications, D: Industrial applications	G: Industrial applications
Operating ambient temperature	$T_A = -40$ to $+85^\circ\text{C}$	$T_A = -40$ to $+105^\circ\text{C}$
Operating mode Operating voltage range	HS (high-speed main) mode: $2.7\text{ V} \leq V_{DD} \leq 5.5\text{ V}@1\text{ MHz to }32\text{ MHz}$ $2.4\text{ V} \leq V_{DD} \leq 5.5\text{ V}@1\text{ MHz to }16\text{ MHz}$ LS (low-speed main) mode: $1.8\text{ V} \leq V_{DD} \leq 5.5\text{ V}@1\text{ MHz to }8\text{ MHz}$ LV (low-voltage main) mode: $1.6\text{ V} \leq V_{DD} \leq 5.5\text{ V}@1\text{ MHz to }4\text{ MHz}$	HS (high-speed main) mode only: $2.7\text{ V} \leq V_{DD} \leq 5.5\text{ V}@1\text{ MHz to }32\text{ MHz}$ $2.4\text{ V} \leq V_{DD} \leq 5.5\text{ V}@1\text{ MHz to }16\text{ MHz}$
High-speed on-chip oscillator clock accuracy	$1.8\text{ V} \leq V_{DD} \leq 5.5\text{ V}$ $\pm 1.0\%@ T_A = -20$ to $+85^\circ\text{C}$ $\pm 1.5\%@ T_A = -40$ to -20°C $1.6\text{ V} \leq V_{DD} < 1.8\text{ V}$ $\pm 5.0\%@ T_A = -20$ to $+85^\circ\text{C}$ $\pm 5.5\%@ T_A = -40$ to -20°C	$2.4\text{ V} \leq V_{DD} \leq 5.5\text{ V}$ $\pm 2.0\%@ T_A = +85$ to $+105^\circ\text{C}$ $\pm 1.0\%@ T_A = -20$ to $+85^\circ\text{C}$ $\pm 1.5\%@ T_A = -40$ to -20°C
Serial array unit	UART Simplified SPI (CSI): $f_{CLK}/2$ (supporting 16 Mbps), $f_{CLK}/4$ Simplified I ² C communication	UART Simplified SPI (CSI): $f_{CLK}/4$ Simplified I ² C communication
IICA	Normal mode Fast mode Fast mode plus	Normal mode Fast mode
Voltage detector	Rise detection voltage: 1.67 V to 4.06 V (14 levels) Fall detection voltage: 1.63 V to 3.98 V (14 levels)	Rise detection voltage: 2.61 V to 4.06 V (8 levels) Fall detection voltage: 2.55 V to 3.98 V (8 levels)

(Remark is listed on the next page.)

Remark The electrical characteristics of the products G: Industrial applications ($T_A = -40$ to $+105^\circ\text{C}$) are different from those of the products “A: Consumer applications, and D: Industrial applications”. For details, refer to **30.1** to **30.10**.

30.1 Absolute Maximum Ratings

Absolute Maximum Ratings ($T_A = 25^\circ\text{C}$) (1/2)

Parameter	Symbols	Conditions	Ratings	Unit
Supply voltage	V_{DD}		-0.5 to +6.5	V
	EV_{DD0}, EV_{DD1}	$EV_{DD0} = EV_{DD1}$	-0.5 to +6.5	V
	EV_{SS0}, EV_{SS1}	$EV_{SS0} = EV_{SS1}$	-0.5 to +0.3	V
REGC pin input voltage	V_{IREGC}	REGC	-0.3 to +2.8 and -0.3 to $V_{DD} + 0.3$ ^{Note 1}	V
Input voltage	V_{I1}	P00 to P07, P10 to P17, P30 to P37, P40 to P47, P50 to P57, P64 to P67, P70 to P77, P80 to P87, P90 to P97, P100 to P106, P110 to P117, P120, P125 to P127, P140 to P147	-0.3 to $EV_{DD0} + 0.3$ and -0.3 to $V_{DD} + 0.3$ ^{Note 2}	V
	V_{I2}	P60 to P63 (N-ch open-drain)	-0.3 to +6.5	V
	V_{I3}	P20 to P27, P121 to P124, P137, P150 to P156, EXCLK, EXCLKS, $\overline{\text{RESET}}$	-0.3 to $V_{DD} + 0.3$ ^{Note 2}	V
Output voltage	V_{O1}	P00 to P07, P10 to P17, P30 to P37, P40 to P47, P50 to P57, P60 to P67, P70 to P77, P80 to P87, P90 to P97, P100 to P106, P110 to P117, P120, P125 to P127, P130, P140 to P147	-0.3 to $EV_{DD0} + 0.3$ and -0.3 to $V_{DD} + 0.3$ ^{Note 2}	V
	V_{O2}	P20 to P27, P150 to P156	-0.3 to $V_{DD} + 0.3$ ^{Note 2}	V
Analog input voltage	V_{AI1}	ANI16 to ANI26	-0.3 to $EV_{DD0} + 0.3$ and -0.3 to $AV_{REF(+)} + 0.3$ ^{Notes 2, 3}	V
	V_{AI2}	ANI0 to ANI14	-0.3 to $V_{DD} + 0.3$ and -0.3 to $AV_{REF(+)} + 0.3$ ^{Notes 2, 3}	V

- Notes 1.** Connect the REGC pin to V_{SS} via a capacitor (0.47 to 1 μF). This value regulates the absolute maximum rating of the REGC pin. Do not use this pin with voltage applied to it.
- 2.** Must be 6.5 V or lower.
- 3.** Do not exceed $AV_{REF(+)} + 0.3$ V in case of A/D conversion target pin.

Caution Product quality may suffer if the absolute maximum rating is exceeded even momentarily for any parameter. That is, the absolute maximum ratings are rated values at which the product is on the verge of suffering physical damage, and therefore the product must be used under conditions that ensure that the absolute maximum ratings are not exceeded.

- Remarks 1.** Unless specified otherwise, the characteristics of alternate-function pins are the same as those of the port pins.
- 2.** $AV_{REF(+)}$: + side reference voltage of the A/D converter.
- 3.** V_{SS} : Reference voltage

Absolute Maximum Ratings (T_A = 25°C) (2/2)

Parameter	Symbols	Conditions		Ratings	Unit
Output current, high	I _{OH1}	Per pin	P00 to P07, P10 to P17, P30 to P37, P40 to P47, P50 to P57, P64 to P67, P70 to P77, P80 to P87, P90 to P97, P100 to P106, P110 to P117, P120, P125 to P127, P130, P140 to P147	-40	mA
		Total of all pins -170 mA	P00 to P04, P07, P32 to P37, P40 to P47, P102 to P106, P120, P125 to P127, P130, P140 to P145	-70	mA
			P05, P06, P10 to P17, P30, P31, P50 to P57, P64 to P67, P70 to P77, P80 to P87, P90 to P97, P100, P101, P110 to P117, P146, P147	-100	mA
	I _{OH2}	Per pin	P20 to P27, P150 to P156	-0.5	mA
		Total of all pins		-2	mA
	Output current, low	I _{OL1}	Per pin	P00 to P07, P10 to P17, P30 to P37, P40 to P47, P50 to P57, P60 to P67, P70 to P77, P80 to P87, P90 to P97, P100 to P106, P110 to P117, P120, P125 to P127, P130, P140 to P147	40
Total of all pins 170 mA			P00 to P04, P07, P32 to P37, P40 to P47, P102 to P106, P120, P125 to P127, P130, P140 to P145	70	mA
			P05, P06, P10 to P17, P30, P31, P50 to P57, P60 to P67, P70 to P77, P80 to P87, P90 to P97, P100, P101, P110 to P117, P146, P147	100	mA
I _{OL2}		Per pin	P20 to P27, P150 to P156	1	mA
		Total of all pins		5	mA
Operating ambient temperature		T _A	In normal operation mode	-40 to +105	°C
	In flash memory programming mode				
Storage temperature	T _{stg}		-65 to +150	°C	

Caution Product quality may suffer if the absolute maximum rating is exceeded even momentarily for any parameter. That is, the absolute maximum ratings are rated values at which the product is on the verge of suffering physical damage, and therefore the product must be used under conditions that ensure that the absolute maximum ratings are not exceeded.

Remark Unless specified otherwise, the characteristics of alternate-function pins are the same as those of the port pins.

30.2 Oscillator Characteristics

30.2.1 X1, XT1 oscillator characteristics

(T_A = -40 to +105°C, 2.4 V ≤ V_{DD} ≤ 5.5 V, V_{SS} = 0 V)

Parameter	Resonator	Conditions	MIN.	TYP.	MAX.	Unit
X1 clock oscillation frequency (f _x) ^{Note}	Ceramic resonator/ crystal resonator	2.7 V ≤ V _{DD} ≤ 5.5 V	1.0		20.0	MHz
		2.4 V ≤ V _{DD} < 2.7 V	1.0		16.0	MHz
XT1 clock oscillation frequency (f _x) ^{Note}	Crystal resonator		32	32.768	35	kHz

Note Indicates only permissible oscillator frequency ranges. Refer to AC Characteristics for instruction execution time. Request evaluation by the manufacturer of the oscillator circuit mounted on a board to check the oscillator characteristics.

Caution Since the CPU is started by the high-speed on-chip oscillator clock after a reset release, check the X1 clock oscillation stabilization time using the oscillation stabilization time counter status register (OSTC) by the user. Determine the oscillation stabilization time of the OSTC register and the oscillation stabilization time select register (OSTS) after sufficiently evaluating the oscillation stabilization time with the resonator to be used.

Remark When using the X1 oscillator and XT1 oscillator, refer to 5.4 System Clock Oscillator.

30.2.2 On-chip oscillator characteristics

(T_A = -40 to +105°C, 2.4 V ≤ V_{DD} ≤ 5.5 V, V_{SS} = 0 V)

Oscillators	Parameters	Conditions		MIN.	TYP.	MAX.	Unit
High-speed on-chip oscillator clock frequency ^{Notes 1, 2}	f _H			1		32	MHz
High-speed on-chip oscillator clock frequency accuracy		-20 to +85°C	2.4 V ≤ V _{DD} ≤ 5.5 V	-1.0		+1.0	%
		-40 to -20°C	2.4 V ≤ V _{DD} ≤ 5.5 V	-1.5		+1.5	%
		+85 to +105°C	2.4 V ≤ V _{DD} ≤ 5.5 V	-2.0		+2.0	%
Low-speed on-chip oscillator clock frequency	f _L				15		kHz
Low-speed on-chip oscillator clock frequency accuracy				-15		+15	%

Notes 1. High-speed on-chip oscillator frequency is selected by bits 0 to 3 of option byte (000C2H/010C2H) and bits 0 to 2 of HOCODIV register.

2. This indicates the oscillator characteristics only. Refer to AC Characteristics for instruction execution time.

30.3 DC Characteristics

30.3.1 Pin characteristics

(T_A = -40 to +105°C, 2.4 V ≤ EV_{DD0} = EV_{DD1} ≤ V_{DD} ≤ 5.5 V, V_{SS} = EV_{SS0} = EV_{SS1} = 0 V) (1/5)

Items	Symbol	Conditions	MIN.	TYP.	MAX.	Unit	
Output current, high ^{Note 1}	I _{OH1}	Per pin for P00 to P07, P10 to P17, P30 to P37, P40 to P47, P50 to P57, P64 to P67, P70 to P77, P80 to P87, P90 to P97, P100 to P106, P110 to P117, P120, P125 to P127, P130, P140 to P147	2.4 V ≤ EV _{DD0} ≤ 5.5 V			-3.0 ^{Note 2}	mA
		Total of P00 to P04, P07, P32 to P37, P40 to P47, P102 to P106, P120, P125 to P127, P130, P140 to P145 (When duty ≤ 70% ^{Note 3})	4.0 V ≤ EV _{DD0} ≤ 5.5 V			-30.0	mA
			2.7 V ≤ EV _{DD0} < 4.0 V			-10.0	mA
			2.4 V ≤ EV _{DD0} < 2.7 V			-5.0	mA
		Total of P05, P06, P10 to P17, P30, P31, P50 to P57, P64 to P67, P70 to P77, P80 to P87, P90 to P97, P100, P101, P110 to P117, P146, P147 (When duty ≤ 70% ^{Note 3})	4.0 V ≤ EV _{DD0} ≤ 5.5 V			-30.0	mA
			2.7 V ≤ EV _{DD0} < 4.0 V			-19.0	mA
	2.4 V ≤ EV _{DD0} < 2.7 V				-10.0	mA	
	Total of all pins (When duty ≤ 70% ^{Note 3})	2.4 V ≤ EV _{DD0} ≤ 5.5 V			-60.0	mA	
	I _{OH2}	Per pin for P20 to P27, P150 to P156	2.4 V ≤ V _{DD} ≤ 5.5 V			-0.1 ^{Note 2}	mA
		Total of all pins (When duty ≤ 70% ^{Note 3})	2.4 V ≤ V _{DD} ≤ 5.5 V			-1.5	mA

Notes 1. Value of current at which the device operation is guaranteed even if the current flows from the EV_{DD0}, EV_{DD1}, V_{DD} pins to an output pin.

2. Do not exceed the total current value.

3. Specification under conditions where the duty factor ≤ 70%.

The output current value that has changed to the duty factor > 70% the duty ratio can be calculated with the following expression (when changing the duty factor from 70% to n%).

- Total output current of pins = (I_{OH} × 0.7)/(n × 0.01)

<Example> Where n = 80% and I_{OH} = -10.0 mA

$$\text{Total output current of pins} = (-10.0 \times 0.7)/(80 \times 0.01) \cong -8.7 \text{ mA}$$

However, the current that is allowed to flow into one pin does not vary depending on the duty factor. A current higher than the absolute maximum rating must not flow into one pin.

Caution P00, P02 to P04, P10 to P15, P17, P43 to P45, P50, P52 to P55, P71, P74, P80 to P82, P96, and P142 to P144 do not output high level in N-ch open-drain mode.

Remark Unless specified otherwise, the characteristics of alternate-function pins are the same as those of the port pins.

($T_A = -40$ to $+105^\circ\text{C}$, $2.4\text{ V} \leq EV_{DD0} = EV_{DD1} \leq V_{DD} \leq 5.5\text{ V}$, $V_{SS} = EV_{SS0} = EV_{SS1} = 0\text{ V}$) (2/5)

Items	Symbol	Conditions	MIN.	TYP.	MAX.	Unit	
Output current, I_{OL} ^{Note 1}	I _{OL1}	Per pin for P00 to P07, P10 to P17, P30 to P37, P40 to P47, P50 to P57, P64 to P67, P70 to P77, P80 to P87, P90 to P97, P100 to P106, P110 to P117, P120, P125 to P127, P130, P140 to P147			8.5 ^{Note 2}	mA	
		Per pin for P60 to P63			15.0 ^{Note 2}	mA	
		Total of P00 to P04, P07, P32 to P37, P40 to P47, P102 to P106, P120, P125 to P127, P130, P140 to P145 (When duty $\leq 70\%$ ^{Note 3})	$4.0\text{ V} \leq EV_{DD0} \leq 5.5\text{ V}$			40.0	mA
			$2.7\text{ V} \leq EV_{DD0} < 4.0\text{ V}$			15.0	mA
			$2.4\text{ V} \leq EV_{DD0} < 2.7\text{ V}$			9.0	mA
		Total of P05, P06, P10 to P17, P30, P31, P50 to P57, P60 to P67, P70 to P77, P80 to P87, P90 to P97, P100, P101, P110 to P117, P146, P147 (When duty $\leq 70\%$ ^{Note 3})	$4.0\text{ V} \leq EV_{DD0} \leq 5.5\text{ V}$			40.0	mA
			$2.7\text{ V} \leq EV_{DD0} < 4.0\text{ V}$			35.0	mA
	$2.4\text{ V} \leq EV_{DD0} < 2.7\text{ V}$				20.0	mA	
	Total of all pins (When duty $\leq 70\%$ ^{Note 3})				80.0	mA	
	I _{OL2}	Per pin for P20 to P27, P150 to P156				0.4 ^{Note 2}	mA
Total of all pins (When duty $\leq 70\%$ ^{Note 3})		$2.4\text{ V} \leq V_{DD} \leq 5.5\text{ V}$			5.0	mA	

Notes 1. Value of current at which the device operation is guaranteed even if the current flows from an output pin to the EV_{SS0} , EV_{SS1} and V_{SS} pin.

2. Do not exceed the total current value.

3. Specification under conditions where the duty factor $\leq 70\%$.

The output current value that has changed to the duty factor $> 70\%$ the duty ratio can be calculated with the following expression (when changing the duty factor from 70% to n%).

- Total output current of pins = $(I_{OL} \times 0.7)/(n \times 0.01)$

<Example> Where $n = 80\%$ and $I_{OL} = 10.0\text{ mA}$

$$\text{Total output current of pins} = (10.0 \times 0.7)/(80 \times 0.01) \cong 8.7\text{ mA}$$

However, the current that is allowed to flow into one pin does not vary depending on the duty factor. A current higher than the absolute maximum rating must not flow into one pin.

Remark Unless specified otherwise, the characteristics of alternate-function pins are the same as those of the port pins.

($T_A = -40$ to $+105^\circ\text{C}$, $2.4\text{ V} \leq EV_{DD0} = EV_{DD1} \leq V_{DD} \leq 5.5\text{ V}$, $V_{SS} = EV_{SS0} = EV_{SS1} = 0\text{ V}$) (3/5)

Items	Symbol	Conditions	MIN.	TYP.	MAX.	Unit	
Input voltage, high	V_{IH1}	P00 to P07, P10 to P17, P30 to P37, P40 to P47, P50 to P57, P64 to P67, P70 to P77, P80 to P87, P90 to P97, P100 to P106, P110 to P117, P120, P125 to P127, P140 to P147	Normal input buffer	$0.8EV_{DD0}$		EV_{DD0}	V
	V_{IH2}	P01, P03, P04, P10, P11, P13 to P17, P43, P44, P53 to P55, P80, P81, P142, P143	TTL input buffer $4.0\text{ V} \leq EV_{DD0} \leq 5.5\text{ V}$	2.2		EV_{DD0}	V
			TTL input buffer $3.3\text{ V} \leq EV_{DD0} < 4.0\text{ V}$	2.0		EV_{DD0}	V
			TTL input buffer $2.4\text{ V} \leq EV_{DD0} < 3.3\text{ V}$	1.5		EV_{DD0}	V
	V_{IH3}	P20 to P27, P150 to P156		$0.7V_{DD}$		V_{DD}	V
	V_{IH4}	P60 to P63		$0.7EV_{DD0}$		6.0	V
V_{IH5}	P121 to P124, P137, EXCLK, EXCLKS, $\overline{\text{RESET}}$		$0.8V_{DD}$		V_{DD}	V	
Input voltage, low	V_{IL1}	P00 to P07, P10 to P17, P30 to P37, P40 to P47, P50 to P57, P64 to P67, P70 to P77, P80 to P87, P90 to P97, P100 to P106, P110 to P117, P120, P125 to P127, P140 to P147	Normal input buffer	0		$0.2EV_{DD0}$	V
	V_{IL2}	P01, P03, P04, P10, P11, P13 to P17, P43, P44, P53 to P55, P80, P81, P142, P143	TTL input buffer $4.0\text{ V} \leq EV_{DD0} \leq 5.5\text{ V}$	0		0.8	V
			TTL input buffer $3.3\text{ V} \leq EV_{DD0} < 4.0\text{ V}$	0		0.5	V
			TTL input buffer $2.4\text{ V} \leq EV_{DD0} < 3.3\text{ V}$	0		0.32	V
	V_{IL3}	P20 to P27, P150 to P156		0		$0.3V_{DD}$	V
	V_{IL4}	P60 to P63		0		$0.3EV_{DD0}$	V
V_{IL5}	P121 to P124, P137, EXCLK, EXCLKS, $\overline{\text{RESET}}$		0		$0.2V_{DD}$	V	

Caution The maximum value of V_{IH} of pins P00, P02 to P04, P10 to P15, P17, P43 to P45, P50, P52 to P55, P71, P74, P80 to P82, P96, and P142 to P144 is EV_{DD0} , even in the N-ch open-drain mode.

Remark Unless specified otherwise, the characteristics of alternate-function pins are the same as those of the port pins.

($T_A = -40$ to $+105^\circ\text{C}$, $2.4\text{ V} \leq EV_{DD0} = EV_{DD1} \leq V_{DD} \leq 5.5\text{ V}$, $V_{SS} = EV_{SS0} = EV_{SS1} = 0\text{ V}$) (4/5)

Items	Symbol	Conditions	MIN.	TYP.	MAX.	Unit
Output voltage, high	V _{OH1}	P00 to P07, P10 to P17, P30 to P37, P40 to P47, P50 to P57, P64 to P67, P70 to P77, P80 to P87, P90 to P97, P100 to P106, P110 to P117, P120, P125 to P127, P130, P140 to P147	$4.0\text{ V} \leq EV_{DD0} \leq 5.5\text{ V}$, $I_{OH1} = -3.0\text{ mA}$	$EV_{DD0} - 0.7$		V
			$2.7\text{ V} \leq EV_{DD0} \leq 5.5\text{ V}$, $I_{OH1} = -2.0\text{ mA}$	$EV_{DD0} - 0.6$		V
			$2.4\text{ V} \leq EV_{DD0} \leq 5.5\text{ V}$, $I_{OH1} = -1.5\text{ mA}$	$EV_{DD0} - 0.5$		V
	V _{OH2}	P20 to P27, P150 to P156	$2.4\text{ V} \leq V_{DD} \leq 5.5\text{ V}$, $I_{OH2} = -100\text{ }\mu\text{A}$	$V_{DD} - 0.5$		V
Output voltage, low	V _{OL1}	P00 to P07, P10 to P17, P30 to P37, P40 to P47, P50 to P57, P64 to P67, P70 to P77, P80 to P87, P90 to P97, P100 to P106, P110 to P117, P120, P125 to P127, P130, P140 to P147	$4.0\text{ V} \leq EV_{DD0} \leq 5.5\text{ V}$, $I_{OL1} = 8.5\text{ mA}$		0.7	V
			$4.0\text{ V} \leq EV_{DD0} \leq 5.5\text{ V}$, $I_{OL1} = 3.0\text{ mA}$		0.6	V
			$2.7\text{ V} \leq EV_{DD0} \leq 5.5\text{ V}$, $I_{OL1} = 1.5\text{ mA}$		0.4	V
			$2.4\text{ V} \leq EV_{DD0} \leq 5.5\text{ V}$, $I_{OL1} = 0.6\text{ mA}$		0.4	V
	V _{OL2}	P20 to P27, P150 to P156	$2.4\text{ V} \leq V_{DD} \leq 5.5\text{ V}$, $I_{OL2} = 400\text{ }\mu\text{A}$		0.4	V
	V _{OL3}	P60 to P63	$4.0\text{ V} \leq EV_{DD0} \leq 5.5\text{ V}$, $I_{OL3} = 15.0\text{ mA}$		2.0	V
			$4.0\text{ V} \leq EV_{DD0} \leq 5.5\text{ V}$, $I_{OL3} = 5.0\text{ mA}$		0.4	V
			$2.7\text{ V} \leq EV_{DD0} \leq 5.5\text{ V}$, $I_{OL3} = 3.0\text{ mA}$		0.4	V
			$2.4\text{ V} \leq EV_{DD0} \leq 5.5\text{ V}$, $I_{OL3} = 2.0\text{ mA}$		0.4	V

Caution P00, P02 to P04, P10 to P15, P17, P43 to P45, P50, P52 to P55, P71, P74, P80 to P82, P96, and P142 to P144 do not output high level in N-ch open-drain mode.

Remark Unless specified otherwise, the characteristics of alternate-function pins are the same as those of the port pins.

($T_A = -40$ to $+105^\circ\text{C}$, $2.4\text{ V} \leq EV_{DD0} = EV_{DD1} \leq V_{DD} \leq 5.5\text{ V}$, $V_{SS} = EV_{SS0} = EV_{SS1} = 0\text{ V}$) (5/5)

Items	Symbol	Conditions	MIN.	TYP.	MAX.	Unit		
Input leakage current, high	I _{LIH1}	P00 to P07, P10 to P17, P30 to P37, P40 to P47, P50 to P57, P60 to P67, P70 to P77, P80 to P87, P90 to P97, P100 to P106, P110 to P117, P120, P125 to P127, P140 to P147	$V_i = EV_{DD0}$			1	μA	
	I _{LIH2}	P20 to P27, P137, P150 to P156, RESET	$V_i = V_{DD}$			1	μA	
	I _{LIH3}	P121 to P124 (X1, X2, XT1, XT2, EXCLK, EXCLKS)	In input port or external clock input			1	μA	
			In resonator connection			10	μA	
Input leakage current, low	I _{LIL1}	P00 to P07, P10 to P17, P30 to P37, P40 to P47, P50 to P57, P60 to P67, P70 to P77, P80 to P87, P90 to P97, P100 to P106, P110 to P117, P120, P125 to P127, P140 to P147	$V_i = EV_{SS0}$			-1	μA	
	I _{LIL2}	P20 to P27, P137, P150 to P156, RESET	$V_i = V_{SS}$			-1	μA	
	I _{LIL3}	P121 to P124 (X1, X2, XT1, XT2, EXCLK, EXCLKS)	In input port or external clock input			-1	μA	
			In resonator connection			-10	μA	
On-chip pll-up resistance	R _U	P00 to P07, P10 to P17, P30 to P37, P40 to P47, P50 to P57, P64 to P67, P70 to P77, P80 to P87, P90 to P97, P100 to P106, P110 to P117, P120, P125 to P127, P140 to P147	$V_i = EV_{SS0}$, In input port		10	20	100	k Ω

Remark Unless specified otherwise, the characteristics of alternate-function pins are the same as those of the port pins.

30.3.2 Supply current characteristics

(1) Flash ROM: 16 to 64 KB of 20- to 64-pin products

 $(T_A = -40$ to $+105^\circ\text{C}$, $2.4\text{ V} \leq V_{DD0} \leq V_{DD} \leq 5.5\text{ V}$, $V_{SS} = EV_{SS0} = 0\text{ V})$ (1/2)

Parameter	Symbol	Conditions				MIN.	TYP.	MAX.	Unit	
Supply current Note 1	I _{DD1}	Operating mode	HS (high-speed main) mode Note 5	$f_{IH} = 32\text{ MHz}$ Note 3	Basic operation	$V_{DD} = 5.0\text{ V}$		2.1		mA
						$V_{DD} = 3.0\text{ V}$		2.1		mA
				Normal operation	$V_{DD} = 5.0\text{ V}$		4.6	7.5	mA	
					$V_{DD} = 3.0\text{ V}$		4.6	7.5	mA	
				$f_{IH} = 24\text{ MHz}$ Note 3	Normal operation	$V_{DD} = 5.0\text{ V}$		3.7	5.8	mA
						$V_{DD} = 3.0\text{ V}$		3.7	5.8	mA
			$f_{IH} = 16\text{ MHz}$ Note 3	Normal operation	$V_{DD} = 5.0\text{ V}$		2.7	4.2	mA	
					$V_{DD} = 3.0\text{ V}$		2.7	4.2	mA	
			HS (high-speed main) mode Note 5	$f_{MX} = 20\text{ MHz}$ Note 2, $V_{DD} = 5.0\text{ V}$	Normal operation	Square wave input		3.0	4.9	mA
						Resonator connection		3.2	5.0	mA
				$f_{MX} = 20\text{ MHz}$ Note 2, $V_{DD} = 3.0\text{ V}$	Normal operation	Square wave input		3.0	4.9	mA
						Resonator connection		3.2	5.0	mA
		$f_{MX} = 10\text{ MHz}$ Note 2, $V_{DD} = 5.0\text{ V}$		Normal operation	Square wave input		1.9	2.9	mA	
					Resonator connection		1.9	2.9	mA	
		$f_{MX} = 10\text{ MHz}$ Note 2, $V_{DD} = 3.0\text{ V}$		Normal operation	Square wave input		1.9	2.9	mA	
					Resonator connection		1.9	2.9	mA	
		Subsystem clock operation	$f_{SUB} = 32.768\text{ kHz}$ Note 4 $T_A = -40^\circ\text{C}$	Normal operation	Square wave input		4.1	4.9	μA	
					Resonator connection		4.2	5.0	μA	
			$f_{SUB} = 32.768\text{ kHz}$ Note 4 $T_A = +25^\circ\text{C}$	Normal operation	Square wave input		4.1	4.9	μA	
					Resonator connection		4.2	5.0	μA	
$f_{SUB} = 32.768\text{ kHz}$ Note 4 $T_A = +50^\circ\text{C}$	Normal operation		Square wave input		4.2	5.5	μA			
			Resonator connection		4.3	5.6	μA			
$f_{SUB} = 32.768\text{ kHz}$ Note 4 $T_A = +70^\circ\text{C}$	Normal operation		Square wave input		4.3	6.3	μA			
			Resonator connection		4.4	6.4	μA			
$f_{SUB} = 32.768\text{ kHz}$ Note 4 $T_A = +85^\circ\text{C}$	Normal operation		Square wave input		4.6	7.7	μA			
			Resonator connection		4.7	7.8	μA			
$f_{SUB} = 32.768\text{ kHz}$ Note 4 $T_A = +105^\circ\text{C}$	Normal operation		Square wave input		6.9	19.7	μA			
			Resonator connection		7.0	19.8	μA			

(Notes and Remarks are listed on the next page.)

- Notes**
1. Total current flowing into V_{DD} and EV_{DD0}, including the input leakage current flowing when the level of the input pin is fixed to V_{DD}, EV_{DD0} or V_{SS}, EV_{SS0}. The following points apply in the HS (high-speed main) mode.
 - The currents in the “TYP.” column do not include the operating currents of the peripheral modules.
 - The currents in the “MAX.” column include the operating currents of the peripheral modules, except for those flowing into the A/D converter, LVD circuit, I/O port, and on-chip pull-up/pull-down resistors, and those flowing while the data flash memory is being rewritten.In the subsystem clock operation, the currents in both the “TYP.” and “MAX.” columns do not include the operating currents of the peripheral modules. However, in HALT mode, including the current flowing into the RTC.
 2. When high-speed on-chip oscillator and subsystem clock are stopped.
 3. When high-speed system clock and subsystem clock are stopped.
 4. When high-speed on-chip oscillator and high-speed system clock are stopped. When AMPHS1 = 1 (Ultra-low power consumption oscillation).
 5. Relationship between operation voltage width, operation frequency of CPU and operation mode is as below.
HS (high-speed main) mode: $2.7\text{ V} \leq V_{DD} \leq 5.5\text{ V}@1\text{ MHz to }32\text{ MHz}$
 $2.4\text{ V} \leq V_{DD} \leq 5.5\text{ V}@1\text{ MHz to }16\text{ MHz}$

- Remarks**
1. f_{MX}: High-speed system clock frequency (X1 clock oscillation frequency or external main system clock frequency)
 2. f_{IH}: High-speed on-chip oscillator clock frequency
 3. f_{SUB}: Subsystem clock frequency (XT1 clock oscillation frequency)
 4. Except subsystem clock operation, temperature condition of the TYP. value is T_A = 25°C

(1) Flash ROM: 16 to 64 KB of 20- to 64-pin products
(T_A = -40 to +105°C, 2.4 V ≤ EV_{DD0} ≤ V_{DD} ≤ 5.5 V, V_{SS} = EV_{SS0} = 0 V) (2/2)

Parameter	Symbol	Conditions			MIN.	TYP.	MAX.	Unit	
Supply current Note 1	I _{DD2} Note 2	HALT mode	HS (high-speed main) mode Note 6	f _{IH} = 32 MHz Note 4	V _{DD} = 5.0 V		0.54	2.90	mA
					V _{DD} = 3.0 V		0.54	2.90	mA
				f _{IH} = 24 MHz Note 4	V _{DD} = 5.0 V		0.44	2.30	mA
					V _{DD} = 3.0 V		0.44	2.30	mA
				f _{IH} = 16 MHz Note 4	V _{DD} = 5.0 V		0.40	1.70	mA
					V _{DD} = 3.0 V		0.40	1.70	mA
			HS (high-speed main) mode Note 6	f _{MX} = 20 MHz Note 3, V _{DD} = 5.0 V	Square wave input		0.28	1.90	mA
					Resonator connection		0.45	2.00	mA
				f _{MX} = 20 MHz Note 3, V _{DD} = 3.0 V	Square wave input		0.28	1.90	mA
					Resonator connection		0.45	2.00	mA
				f _{MX} = 10 MHz Note 3, V _{DD} = 5.0 V	Square wave input		0.19	1.02	mA
					Resonator connection		0.26	1.10	mA
				f _{MX} = 10 MHz Note 3, V _{DD} = 3.0 V	Square wave input		0.19	1.02	mA
					Resonator connection		0.26	1.10	mA
	Subsystem clock operation	f _{SUB} = 32.768 kHz Note 5 T _A = -40°C	Square wave input		0.25	0.57	μA		
			Resonator connection		0.44	0.76	μA		
		f _{SUB} = 32.768 kHz Note 5 T _A = +25°C	Square wave input		0.30	0.57	μA		
			Resonator connection		0.49	0.76	μA		
		f _{SUB} = 32.768 kHz Note 5 T _A = +50°C	Square wave input		0.37	1.17	μA		
			Resonator connection		0.56	1.36	μA		
f _{SUB} = 32.768 kHz Note 5 T _A = +70°C		Square wave input		0.53	1.97	μA			
		Resonator connection		0.72	2.16	μA			
f _{SUB} = 32.768 kHz Note 5 T _A = +85°C	Square wave input		0.82	3.37	μA				
	Resonator connection		1.01	3.56	μA				
f _{SUB} = 32.768 kHz Note 5 T _A = +105°C	Square wave input		3.01	15.37	μA				
	Resonator connection		3.20	15.56	μA				
I _{DD3}	STOP mode Note 7	T _A = -40°C				0.18	0.50	μA	
		T _A = +25°C				0.23	0.50	μA	
		T _A = +50°C				0.30	1.10	μA	
		T _A = +70°C				0.46	1.90	μA	
		T _A = +85°C				0.75	3.30	μA	
		T _A = +105°C				2.94	15.30	μA	

(Notes and Remarks are listed on the next page.)

Notes 1. Total current flowing into V_{DD} and EV_{DD0} , including the input leakage current flowing when the level of the input pin is fixed to V_{DD} , EV_{DD0} or V_{SS} , EV_{SS0} . The following points apply in the HS (high-speed main) mode.

- The currents in the “TYP.” column do not include the operating currents of the peripheral modules.
- The currents in the “MAX.” column include the operating currents of the peripheral modules, except for those flowing into the A/D converter, LVD circuit, I/O port, and on-chip pull-up/pull-down resistors, and those flowing while the data flash memory is being rewritten.

In the subsystem clock operation, the currents in both the “TYP.” and “MAX.” columns do not include the operating currents of the peripheral modules. However, in HALT mode, including the current flowing into the RTC.

In the STOP mode, the currents in both the “TYP.” and “MAX.” columns do not include the operating currents of the peripheral modules.

2. During HALT instruction execution by flash memory.
3. When high-speed on-chip oscillator and subsystem clock are stopped.
4. When high-speed system clock and subsystem clock are stopped.
5. When high-speed on-chip oscillator and high-speed system clock are stopped. When $RTCLPC = 1$ and setting ultra-low current consumption ($AMPHS1 = 1$).
6. Relationship between operation voltage width, operation frequency of CPU and operation mode is as below.
 HS (high-speed main) mode: $2.7\text{ V} \leq V_{DD} \leq 5.5\text{ V}@1\text{ MHz to }32\text{ MHz}$
 $2.4\text{ V} \leq V_{DD} \leq 5.5\text{ V}@1\text{ MHz to }16\text{ MHz}$
- 7 Regarding the value for current operate the subsystem clock in STOP mode, refer to that in HALT mode.

Remarks 1. f_{MX} : High-speed system clock frequency (X1 clock oscillation frequency or external main system clock frequency)

2. f_{IH} : High-speed on-chip oscillator clock frequency
3. f_{SUB} : Subsystem clock frequency (XT1 clock oscillation frequency)
4. Except subsystem clock operation and STOP mode, temperature condition of the TYP. value is $T_A = 25^\circ\text{C}$

(2) Flash ROM: 96 to 256 KB of 30- to 100-pin products

(T_A = -40 to +105°C, 2.4 V ≤ EV_{DD0} = EV_{DD1} ≤ V_{DD} ≤ 5.5 V, V_{SS} = EV_{SS0} = EV_{SS1} = 0 V) (1/2)

Parameter	Symbol	Conditions				MIN.	TYP.	MAX.	Unit	
Supply current Note 1	I _{DD1}	Operating mode	HS (high-speed main) mode Note 5	f _{IH} = 32 MHz Note 3	Basic operation	V _{DD} = 5.0 V		2.3		mA
						V _{DD} = 3.0 V		2.3		mA
				Normal operation	V _{DD} = 5.0 V		5.2	9.2	mA	
					V _{DD} = 3.0 V		5.2	9.2	mA	
				Normal operation	V _{DD} = 5.0 V		4.1	7.0	mA	
					V _{DD} = 3.0 V		4.1	7.0	mA	
			HS (high-speed main) mode Note 5	f _{IH} = 24 MHz Note 3	Normal operation	V _{DD} = 5.0 V		4.1	7.0	mA
						V _{DD} = 3.0 V		4.1	7.0	mA
				f _{IH} = 16 MHz Note 3	Normal operation	V _{DD} = 5.0 V		3.0	5.0	mA
						V _{DD} = 3.0 V		3.0	5.0	mA
		Subsystem clock operation	f _{SUB} = 32.768 kHz Note 4	Normal operation	Square wave input		4.8	5.9	μA	
					Resonator connection		4.9	6.0	μA	
				Normal operation	Square wave input		4.9	5.9	μA	
					Resonator connection		5.0	6.0	μA	
			Normal operation	Square wave input		5.0	7.6	μA		
				Resonator connection		5.1	7.7	μA		
			Normal operation	Square wave input		5.2	9.3	μA		
				Resonator connection		5.3	9.4	μA		
		Normal operation	Square wave input		5.7	13.3	μA			
			Resonator connection		5.8	13.4	μA			
Normal operation	Square wave input		10.0	46.0	μA					
	Resonator connection		10.0	46.0	μA					

(Notes and Remarks are listed on the next page.)

Notes 1. Total current flowing into V_{DD}, EV_{DD0}, and EV_{DD1}, including the input leakage current flowing when the level of the input pin is fixed to V_{DD}, EV_{DD0}, and EV_{DD1}, or V_{SS}, EV_{SS0}, and EV_{SS1}. The following points apply in the HS (high-speed main) mode.

- The currents in the “TYP.” column do not include the operating currents of the peripheral modules.
- The currents in the “MAX.” column include the operating currents of the peripheral modules, except for those flowing into the A/D converter, LVD circuit, I/O port, and on-chip pull-up/pull-down resistors, and those flowing while the data flash memory is being rewritten.

In the subsystem clock operation, the currents in both the “TYP.” and “MAX.” columns do not include the operating currents of the peripheral modules. However, in HALT mode, including the current flowing into the RTC.

2. When high-speed on-chip oscillator and subsystem clock are stopped.
3. When high-speed system clock and subsystem clock are stopped.
4. When high-speed on-chip oscillator and high-speed system clock are stopped. When AMPHS1 = 1 (Ultra-low power consumption oscillation).
5. Relationship between operation voltage width, operation frequency of CPU and operation mode is as below.

HS (high-speed main) mode: $2.7\text{ V} \leq V_{DD} \leq 5.5\text{ V}@1\text{ MHz to }32\text{ MHz}$

$2.4\text{ V} \leq V_{DD} \leq 5.5\text{ V}@1\text{ MHz to }16\text{ MHz}$

Remarks 1. f_{MX}: High-speed system clock frequency (X1 clock oscillation frequency or external main system clock frequency)

2. f_{IH}: High-speed on-chip oscillator clock frequency
3. f_{SUB}: Subsystem clock frequency (XT1 clock oscillation frequency)
4. Except subsystem clock operation, temperature condition of the TYP. value is T_A = 25°C

(2) Flash ROM: 96 to 256 KB of 30- to 100-pin products
(T_A = -40 to +105°C, 2.4 V ≤ EV_{DD0} = EV_{DD1} ≤ V_{DD} ≤ 5.5 V, V_{SS} = EV_{SS0} = EV_{SS1} = 0 V) (2/2)

Parameter	Symbol	Conditions		MIN.	TYP.	MAX.	Unit		
Supply current Note 1	I _{DD2} Note 2	HALT mode	HS (high-speed main) mode Note 6	f _{IH} = 32 MHz Note 4	V _{DD} = 5.0 V		0.62	3.40	mA
					V _{DD} = 3.0 V		0.62	3.40	mA
				f _{IH} = 24 MHz Note 4	V _{DD} = 5.0 V		0.50	2.70	mA
					V _{DD} = 3.0 V		0.50	2.70	mA
				f _{IH} = 16 MHz Note 4	V _{DD} = 5.0 V		0.44	1.90	mA
					V _{DD} = 3.0 V		0.44	1.90	mA
			HS (high-speed main) mode Note 6	f _{MX} = 20 MHz Note 3, V _{DD} = 5.0 V	Square wave input		0.31	2.10	mA
					Resonator connection		0.48	2.20	mA
				f _{MX} = 20 MHz Note 3, V _{DD} = 3.0 V	Square wave input		0.31	2.10	mA
					Resonator connection		0.48	2.20	mA
				f _{MX} = 10 MHz Note 3, V _{DD} = 5.0 V	Square wave input		0.21	1.10	mA
					Resonator connection		0.28	1.20	mA
				f _{MX} = 10 MHz Note 3, V _{DD} = 3.0 V	Square wave input		0.21	1.10	mA
					Resonator connection		0.28	1.20	mA
		Subsystem clock operation	f _{SUB} = 32.768 kHz Note 5 T _A = -40°C	Square wave input		0.28	0.61	μA	
				Resonator connection		0.47	0.80	μA	
			f _{SUB} = 32.768 kHz Note 5 T _A = +25°C	Square wave input		0.34	0.61	μA	
				Resonator connection		0.53	0.80	μA	
			f _{SUB} = 32.768 kHz Note 5 T _A = +50°C	Square wave input		0.41	2.30	μA	
				Resonator connection		0.60	2.49	μA	
f _{SUB} = 32.768 kHz Note 5 T _A = +70°C	Square wave input			0.64	4.03	μA			
	Resonator connection			0.83	4.22	μA			
f _{SUB} = 32.768 kHz Note 5 T _A = +85°C	Square wave input			1.09	8.04	μA			
	Resonator connection			1.28	8.23	μA			
f _{SUB} = 32.768 kHz Note 5 T _A = +105°C	Square wave input		5.50	41.00	μA				
	Resonator connection		5.50	41.00	μA				
I _{DD3}	STOP mode Note 7	T _A = -40°C		0.19	0.52	μA			
		T _A = +25°C		0.25	0.52	μA			
		T _A = +50°C		0.32	2.21	μA			
		T _A = +70°C		0.55	3.94	μA			
		T _A = +85°C		1.00	7.95	μA			
		T _A = +105°C		5.00	40.00	μA			

(Notes and Remarks are listed on the next page.)

Notes 1. Total current flowing into V_{DD} , EV_{DD0} , and EV_{DD1} , including the input leakage current flowing when the level of the input pin is fixed to V_{DD} , EV_{DD0} , and EV_{DD1} , or V_{SS} , EV_{SS0} , and EV_{SS1} . The following points apply in the HS (high-speed main) mode.

- The currents in the “TYP.” column do not include the operating currents of the peripheral modules.
- The currents in the “MAX.” column include the operating currents of the peripheral modules, except for those flowing into the A/D converter, LVD circuit, I/O port, and on-chip pull-up/pull-down resistors, and those flowing while the data flash memory is being rewritten.

In the subsystem clock operation, the currents in both the “TYP.” and “MAX.” columns do not include the operating currents of the peripheral modules. However, in HALT mode, including the current flowing into the RTC.

In the STOP mode, the currents in both the “TYP.” and “MAX.” columns do not include the operating currents of the peripheral modules.

2. During HALT instruction execution by flash memory.
3. When high-speed on-chip oscillator and subsystem clock are stopped.
4. When high-speed system clock and subsystem clock are stopped.
5. When high-speed on-chip oscillator and high-speed system clock are stopped. When $RTCLPC = 1$ and setting ultra-low current consumption ($AMPHS1 = 1$).
6. Relationship between operation voltage width, operation frequency of CPU and operation mode is as below.
 - HS (high-speed main) mode: $2.7\text{ V} \leq V_{DD} \leq 5.5\text{ V}@1\text{ MHz to }32\text{ MHz}$
 - $2.4\text{ V} \leq V_{DD} \leq 5.5\text{ V}@1\text{ MHz to }16\text{ MHz}$

7. Regarding the value for current operate the subsystem clock in STOP mode, refer to that in HALT mode.

Remarks 1. f_{MX} : High-speed system clock frequency (X1 clock oscillation frequency or external main system clock frequency)

2. f_{IH} : High-speed on-chip oscillator clock frequency
3. f_{SUB} : Subsystem clock frequency (XT1 clock oscillation frequency)
4. Except subsystem clock operation and STOP mode, temperature condition of the TYP. value is $T_A = 25^\circ\text{C}$

(3) Peripheral Functions (Common to all products)**(T_A = -40 to +105°C, 2.4 V ≤ EV_{DD0} = EV_{DD1} ≤ V_{DD} ≤ 5.5 V, V_{SS} = EV_{SS0} = EV_{SS1} = 0 V)**

Parameter	Symbol	Conditions		MIN.	TYP.	MAX.	Unit
Low-speed on-chip oscillator operating current	I _{FIL} Note 1				0.20		μA
RTC operating current	I _{RTC} Notes 1, 2, 3				0.02		μA
12-bit interval timer operating current	I _{IT} Notes 1, 2, 4				0.02		μA
Watchdog timer operating current	I _{WDT} Notes 1, 2, 5	f _{IL} = 15 kHz			0.22		μA
A/D converter operating current	I _{ADC} Notes 1, 6	When conversion at maximum speed	Normal mode, AV _{REFP} = V _{DD} = 5.0 V		1.3	1.7	mA
			Low voltage mode, AV _{REFP} = V _{DD} = 3.0 V		0.5	0.7	mA
A/D converter reference voltage current	I _{ADREF} Note 1				75.0		μA
Temperature sensor operating current	I _{TMPS} Note 1				75.0		μA
LVD operating current	I _{LVD} Notes 1, 7				0.08		μA
Self programming operating current	I _{FSP} Notes 1, 9				2.50	12.20	mA
BGO operating current	I _{BGO} Notes 1, 8				2.50	12.20	mA
SNOOZE operating current	I _{SNOZ} Note 1	ADC operation	The mode is performed ^{Note 10}		0.50	1.10	mA
			The A/D conversion operations are performed, low-voltage mode, AV _{REFP} = V _{DD} = 3.0 V		1.20	2.04	mA
		Simplified SPI (CSI)/UART operation			0.70	1.54	mA

Notes 1. Current flowing to the V_{DD}.

- When high speed on-chip oscillator and high-speed system clock are stopped.
- Current flowing only to the real-time clock (RTC) (excluding the operating current of the low-speed on-chip oscillator and the XT1 oscillator). The supply current of the RL78 microcontrollers is the sum of the values of either I_{DD1} or I_{DD2}, and I_{RTC}, when the real-time clock operates in operation mode or HALT mode. When the low-speed on-chip oscillator is selected, I_{FIL} should be added. I_{DD2} subsystem clock operation includes the operational current of the real-time clock.
- Current flowing only to the 12-bit interval timer (excluding the operating current of the low-speed on-chip oscillator and the XT1 oscillator). The supply current of the RL78 microcontrollers is the sum of the values of either I_{DD1} or I_{DD2}, and I_{IT}, when the 12-bit interval timer operates in operation mode or HALT mode. When the low-speed on-chip oscillator is selected, I_{FIL} should be added.
- Current flowing only to the watchdog timer (including the operating current of the low-speed on-chip oscillator). The supply current of the RL78 is the sum of I_{DD1}, I_{DD2} or I_{DD3} and I_{WDT} when the watchdog timer operates.
- Current flowing only to the A/D converter. The supply current of the RL78 microcontrollers is the sum of I_{DD1} or I_{DD2} and I_{ADC} when the A/D converter is in operation.

- Notes**
7. Current flowing only to the LVD circuit. The supply current of the RL78 microcontrollers is the sum of I_{DD1} , I_{DD2} or I_{DD3} and I_{LVD} when the LVD circuit is in operation.
 8. Current flowing only during data flash rewrite.
 9. Current flowing only during self programming.
 10. For shift time to the SNOOZE mode, see **18.3.3 SNOOZE mode**.

- Remarks**
1. f_{IL} : Low-speed on-chip oscillator clock frequency
 2. f_{SUB} : Subsystem clock frequency (XT1 clock oscillation frequency)
 3. f_{CLK} : CPU/peripheral hardware clock frequency
 4. Temperature condition of the TYP. value is $T_A = 25^\circ\text{C}$

30.4 AC Characteristics

(T_A = -40 to +105°C, 2.4 V ≤ E_{VDD0} = E_{VDD1} ≤ V_{DD} ≤ 5.5 V, V_{SS} = E_{VSS0} = E_{VSS1} = 0 V)

Items	Symbol	Conditions		MIN.	TYP.	MAX.	Unit	
Instruction cycle (minimum instruction execution time)	T _{CY}	Main system clock (f _{MAIN}) operation	HS (high-speed main) mode	2.7 V ≤ V _{DD} ≤ 5.5 V	0.03125	1	μs	
				2.4 V ≤ V _{DD} < 2.7 V	0.0625	1	μs	
		Subsystem clock (f _{SUB}) operation		2.4 V ≤ V _{DD} ≤ 5.5 V	28.5	30.5	31.3	μs
		In the self programming mode	HS (high-speed main) mode	2.7 V ≤ V _{DD} ≤ 5.5 V	0.03125	1	μs	
	2.4 V ≤ V _{DD} < 2.7 V		0.0625	1	μs			
External system clock frequency	f _{EX}	2.7 V ≤ V _{DD} ≤ 5.5 V		1.0		20.0	MHz	
		2.4 V ≤ V _{DD} < 2.7 V		1.0		16.0	MHz	
	f _{EXS}			32		35	kHz	
External system clock input high-level width, low-level width	t _{EXH} , t _{EXL}	2.7 V ≤ V _{DD} ≤ 5.5 V		24			ns	
		2.4 V ≤ V _{DD} < 2.7 V		30			ns	
	t _{EXHS} , t _{EXLS}			13.7			μs	
TI00 to TI07, TI10 to TI17 input high-level width, low-level width	t _{TIH} , t _{TIL}			1/f _{MCK} +10			ns ^{Note}	
TO00 to TO07, TO10 to TO17 output frequency	f _{TO}	HS (high-speed main) mode	4.0 V ≤ E _{VDD0} ≤ 5.5 V			16	MHz	
			2.7 V ≤ E _{VDD0} < 4.0 V			8	MHz	
			2.4 V ≤ E _{VDD0} < 2.7 V			4	MHz	
PCLBUZ0, PCLBUZ1 output frequency	f _{PCL}	HS (high-speed main) mode	4.0 V ≤ E _{VDD0} ≤ 5.5 V			16	MHz	
			2.7 V ≤ E _{VDD0} < 4.0 V			8	MHz	
			2.4 V ≤ E _{VDD0} < 2.7 V			4	MHz	
Interrupt input high-level width, low-level width	t _{INTH} , t _{INTL}	INTP0	2.4 V ≤ V _{DD} ≤ 5.5 V	1			μs	
		INTP1 to INTP11	2.4 V ≤ E _{VDD0} ≤ 5.5 V	1			μs	
Key interrupt input low-level width	t _{KR}	KR0 to KR7	2.4 V ≤ E _{VDD0} ≤ 5.5 V	250			ns	
RESET low-level width	t _{RSL}			10			μs	

Note The following conditions are required for low voltage interface when E_{VDD0} < V_{DD}
 2.4 V ≤ E_{VDD0} < 2.7 V : MIN. 125 ns

Remark f_{MCK}: Timer array unit operation clock frequency
 (Operation clock to be set by the CKSmn0, CKSmn1 bits of timer mode register mn (TMRmn).
 m: Unit number (m = 0, 1), n: Channel number (n = 0 to 7))

Minimum Instruction Execution Time during Main System Clock Operation

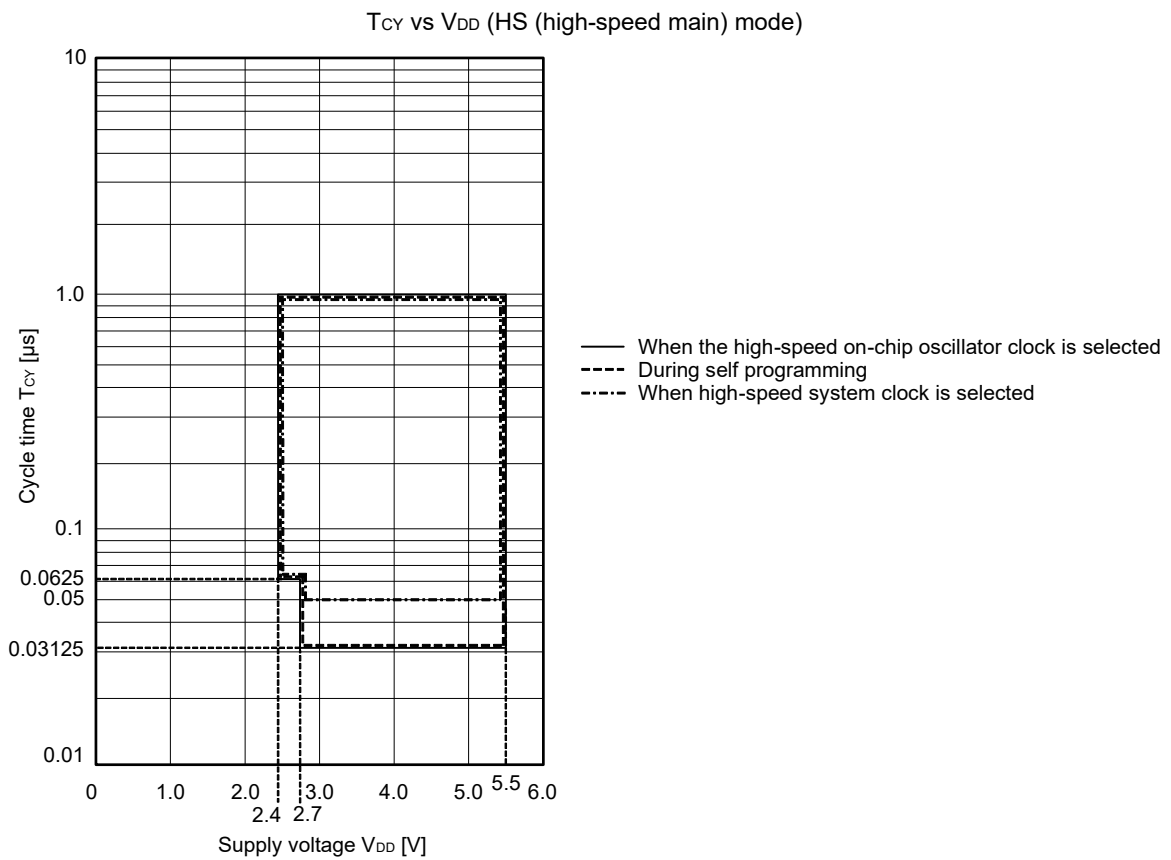

AC Timing Test Points

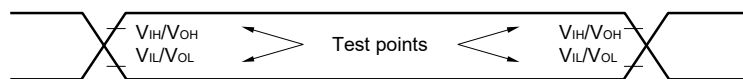

External System Clock Timing

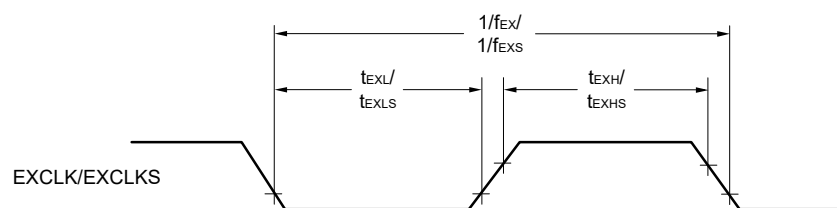

TI/TO Timing

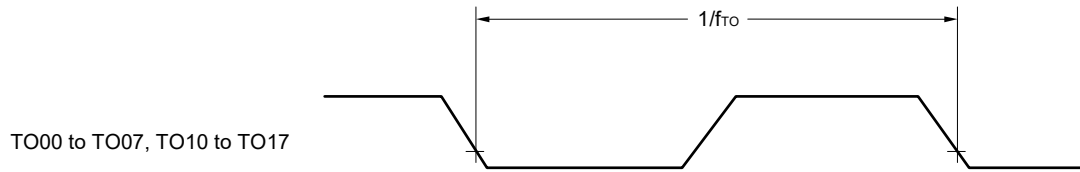
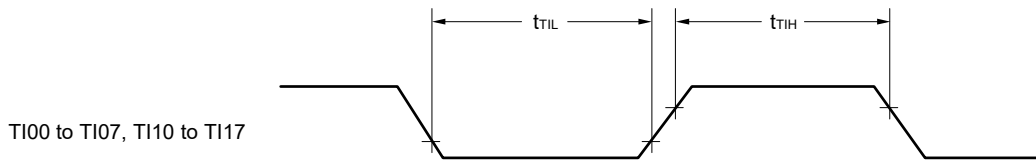

Interrupt Request Input Timing

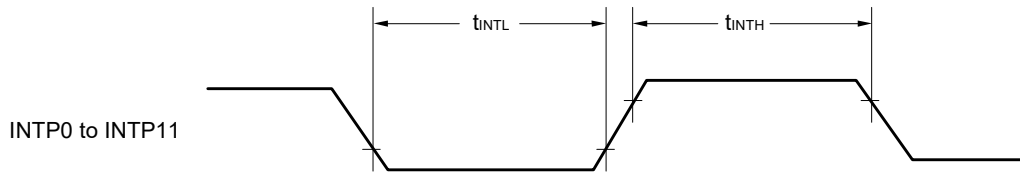

Key Interrupt Input Timing

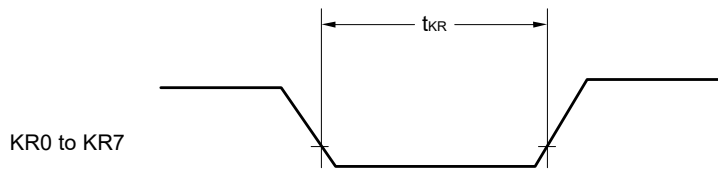

RESET Input Timing

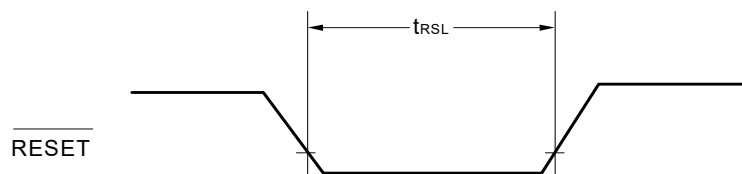

30.5 Peripheral Functions Characteristics

AC Timing Test Points

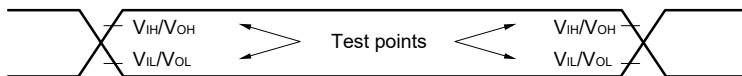

30.5.1 Serial array unit

(1) During communication at same potential (UART mode)

(T_A = -40 to +105°C, 2.4 V ≤ E_{VDD0} = E_{VDD1} ≤ V_{DD} ≤ 5.5 V, V_{SS} = E_{VSS0} = E_{VSS1} = 0 V)

Parameter	Symbol	Conditions	HS (high-speed main) Mode		Unit
			MIN.	MAX.	
Transfer rate ^{Note 1}		Theoretical value of the maximum transfer rate f _{CLK} = 32 MHz, f _{MCK} = f _{CLK}		f _{MCK} /12 ^{Note 2}	bps
				2.6	Mbps

Notes 1. Transfer rate in the SNOOZE mode is 4800 bps only.

- 2.** The following conditions are required for low voltage interface when E_{VDD0} < V_{DD}.
2.4 V ≤ E_{VDD0} < 2.7 V : MAX. 1.3 Mbps

Caution Select the normal input buffer for the Rx_{Dq} pin and the normal output mode for the Tx_{Dq} pin by using port input mode register g (PIMg) and port output mode register g (POMg).

UART mode connection diagram (during communication at same potential)

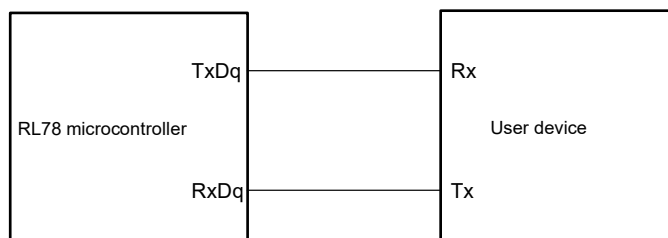

UART mode bit width (during communication at same potential) (reference)

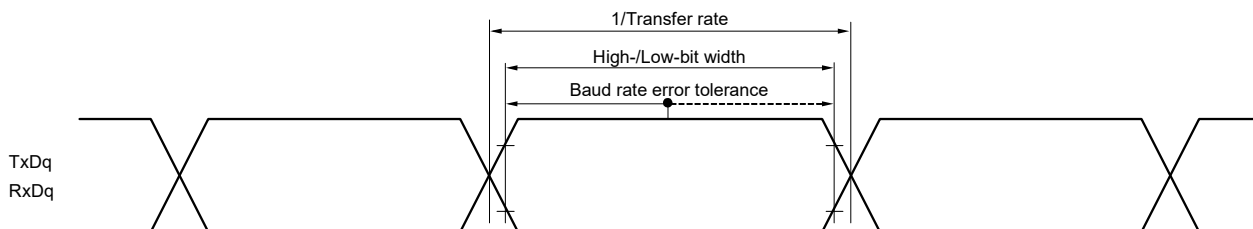

Remarks 1. q: UART number (q = 0 to 3), g: PIM and POM number (g = 0, 1, 8, 14)

2. f_{MCK}: Serial array unit operation clock frequency

(Operation clock to be set by the CKSmn bit of serial mode register mn (SMRmn). m: Unit number, n: Channel number (mn = 00 to 03, 10 to 13))

(2) During communication at same potential (Simplified SPI (CSI) mode) (master mode, SCKp... internal clock output)

 (T_A = -40 to +105°C, 2.4 V ≤ EV_{DD0} = EV_{DD1} ≤ V_{DD} ≤ 5.5 V, V_{SS} = EV_{SS0} = EV_{SS1} = 0 V)

Parameter	Symbol	Conditions	HS (high-speed main) Mode		Unit	
			MIN.	MAX.		
SCKp cycle time	t _{KCY1}	t _{KCY1} ≥ 4/f _{CLK}	2.7 V ≤ EV _{DD0} ≤ 5.5 V	250		ns
			2.4 V ≤ EV _{DD0} ≤ 5.5 V	500		ns
SCKp high-/low-level width	t _{KH1} , t _{KL1}	4.0 V ≤ EV _{DD0} ≤ 5.5 V		t _{KCY1} /2 – 24		ns
		2.7 V ≤ EV _{DD0} ≤ 5.5 V		t _{KCY1} /2 – 36		ns
		2.4 V ≤ EV _{DD0} ≤ 5.5 V		t _{KCY1} /2 – 76		ns
Slp setup time (to SCKp↑) ^{Note 1}	t _{SIK1}	4.0 V ≤ EV _{DD0} ≤ 5.5 V		66		ns
		2.7 V ≤ EV _{DD0} ≤ 5.5 V		66		ns
		2.4 V ≤ EV _{DD0} ≤ 5.5 V		113		ns
Slp hold time (from SCKp↑) ^{Note 2}	t _{KSI1}			38		ns
Delay time from SCKp↓ to SOp output ^{Note 3}	t _{KSO1}	C = 30 pF ^{Note 4}			50	ns

- Notes**
1. When DAP_{mn} = 0 and CKP_{mn} = 0, or DAP_{mn} = 1 and CKP_{mn} = 1. The Slp setup time becomes “to SCKp↓” when DAP_{mn} = 0 and CKP_{mn} = 1, or DAP_{mn} = 1 and CKP_{mn} = 0.
 2. When DAP_{mn} = 0 and CKP_{mn} = 0, or DAP_{mn} = 1 and CKP_{mn} = 1. The Slp hold time becomes “from SCKp↓” when DAP_{mn} = 0 and CKP_{mn} = 1, or DAP_{mn} = 1 and CKP_{mn} = 0.
 3. When DAP_{mn} = 0 and CKP_{mn} = 0, or DAP_{mn} = 1 and CKP_{mn} = 1. The delay time to SOp output becomes “from SCKp↑” when DAP_{mn} = 0 and CKP_{mn} = 1, or DAP_{mn} = 1 and CKP_{mn} = 0.
 4. C is the load capacitance of the SCKp and SOp output lines.

Caution Select the normal input buffer for the Slp pin and the normal output mode for the SOp pin and SCKp pin by using port input mode register g (PIMg) and port output mode register g (POMg).

- Remarks**
1. p: CSI number (p = 00, 01, 10, 11, 20, 21, 30, 31), m: Unit number (m = 0, 1), n: Channel number (n = 0 to 3), g: PIM and POM numbers (g = 0, 1, 4, 5, 8, 14)
 2. f_{MCK}: Serial array unit operation clock frequency
(Operation clock to be set by the CKS_{mn} bit of serial mode register mn (SMR_{mn}). m: Unit number, n: Channel number (mn = 00 to 03, 10 to 13))

(3) During communication at same potential (Simplified SPI (CSI) mode) (slave mode, SCKp... external clock input)

 (T_A = -40 to +105°C, 2.4 V ≤ EV_{DD0} = EV_{DD1} ≤ V_{DD} ≤ 5.5 V, V_{SS} = EV_{SS0} = EV_{SS1} = 0 V)

Parameter	Symbol	Conditions		HS (high-speed main) Mode		Unit
				MIN.	MAX.	
SCKp cycle time ^{Note 5}	t _{KCY2}	4.0 V ≤ EV _{DD0} ≤ 5.5 V	20 MHz < f _{MCK}	16/f _{MCK}		ns
			f _{MCK} ≤ 20 MHz	12/f _{MCK}		ns
		2.7 V ≤ EV _{DD0} ≤ 5.5 V	16 MHz < f _{MCK}	16/f _{MCK}		ns
			f _{MCK} ≤ 16 MHz	12/f _{MCK}		ns
		2.4 V ≤ EV _{DD0} ≤ 5.5 V	16/f _{MCK}		ns	
12/f _{MCK} and 1000			ns			
SCKp high-/low-level width	t _{KH2} , t _{KL2}	4.0 V ≤ EV _{DD0} ≤ 5.5 V		t _{KCY2} /2 – 14		ns
		2.7 V ≤ EV _{DD0} ≤ 5.5 V		t _{KCY2} /2 – 16		ns
		2.4 V ≤ EV _{DD0} ≤ 5.5 V		t _{KCY2} /2 – 36		ns
Slp setup time (to SCKp↑) ^{Note 1}	t _{SIK2}	2.7 V ≤ EV _{DD0} ≤ 5.5 V		1/f _{MCK} +40		ns
		2.4 V ≤ EV _{DD0} ≤ 5.5 V		1/f _{MCK} +60		ns
Slp hold time (from SCKp↑) ^{Note 2}	t _{KS12}	2.4 V ≤ EV _{DD0} ≤ 5.5 V		1/f _{MCK} +62		ns
Delay time from SCKp↓ to SOp output ^{Note 3}	t _{KSO2}	C = 30 pF ^{Note 4}	2.7 V ≤ EV _{DD0} ≤ 5.5 V		2/f _{MCK} +66	ns
			2.4 V ≤ EV _{DD0} ≤ 5.5 V		2/f _{MCK} +113	ns

- Notes**
1. When DAP_{mn} = 0 and CKP_{mn} = 0, or DAP_{mn} = 1 and CKP_{mn} = 1. The Slp setup time becomes “to SCKp↓” when DAP_{mn} = 0 and CKP_{mn} = 1, or DAP_{mn} = 1 and CKP_{mn} = 0.
 2. When DAP_{mn} = 0 and CKP_{mn} = 0, or DAP_{mn} = 1 and CKP_{mn} = 1. The Slp hold time becomes “from SCKp↓” when DAP_{mn} = 0 and CKP_{mn} = 1, or DAP_{mn} = 1 and CKP_{mn} = 0.
 3. When DAP_{mn} = 0 and CKP_{mn} = 0, or DAP_{mn} = 1 and CKP_{mn} = 1. The delay time to SOp output becomes “from SCKp↑” when DAP_{mn} = 0 and CKP_{mn} = 1, or DAP_{mn} = 1 and CKP_{mn} = 0.
 4. C is the load capacitance of the SOp output lines.
 5. Transfer rate in the SNOOZE mode : MAX. 1 Mbps

Caution Select the normal input buffer for the Slp pin and SCKp pin and the normal output mode for the SOp pin by using port input mode register g (PIMg) and port output mode register g (POMg).

- Remarks**
1. p: CSI number (p = 00, 01, 10, 11, 20, 21, 30, 31), m: Unit number (m = 0, 1), n: Channel number (n = 0 to 3), g: PIM number (g = 0, 1, 4, 5, 8, 14)
 2. f_{MCK}: Serial array unit operation clock frequency (Operation clock to be set by the CKS_{mn} bit of serial mode register mn (SMR_{mn}). m: Unit number, n: Channel number (mn = 00 to 03, 10 to 13))

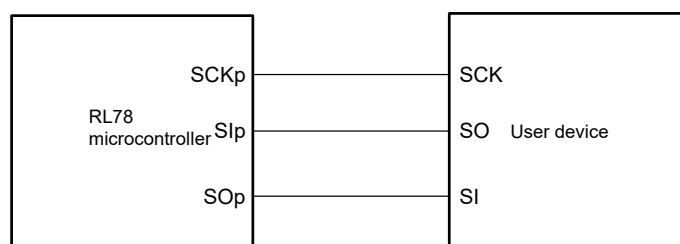
Simplified SPI (CSI) mode connection diagram (during communication at same potential)

Simplified SPI (CSI) mode serial transfer timing (during communication at same potential)
(When DAPmn = 0 and CKPmn = 0, or DAPmn = 1 and CKPmn = 1.)

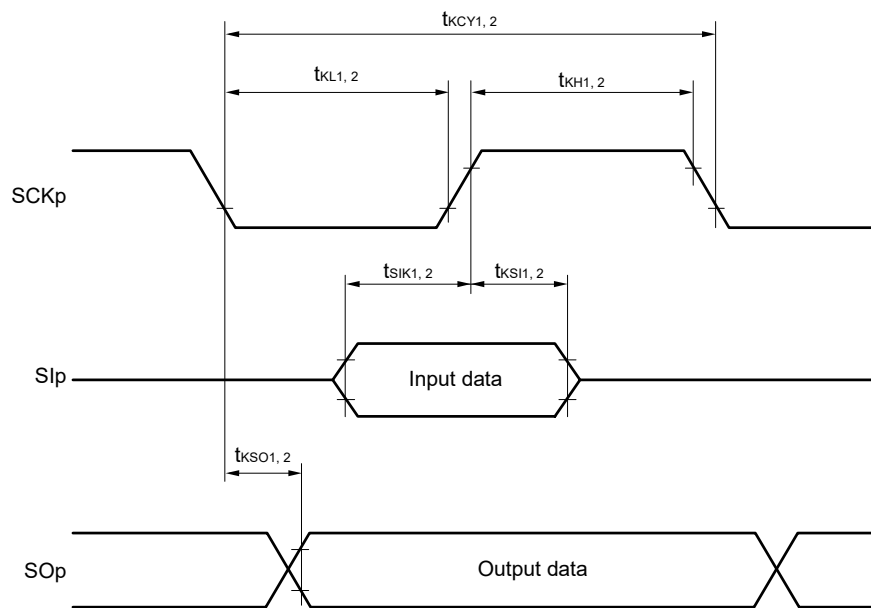

Simplified SPI (CSI) mode serial transfer timing (during communication at same potential)
(When DAPmn = 0 and CKPmn = 1, or DAPmn = 1 and CKPmn = 0.)

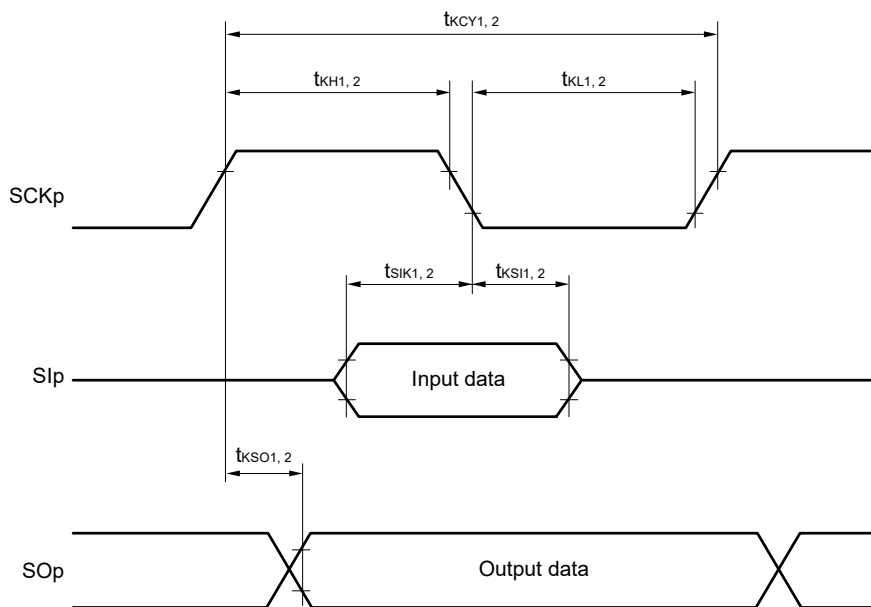

- Remarks**
1. p: CSI number (p = 00, 01, 10, 11, 20, 21, 30, 31)
 2. m: Unit number, n: Channel number (mn = 00 to 03, 10 to 13)

(4) During communication at same potential (simplified I²C mode)
(T_A = -40 to +105°C, 2.4 V ≤ EV_{DD0} = EV_{DD1} ≤ V_{DD} ≤ 5.5 V, V_{SS} = EV_{SS0} = EV_{SS1} = 0 V)

Parameter	Symbol	Conditions	HS (high-speed main) Mode		Unit
			MIN.	MAX.	
SCLr clock frequency	f _{SCL}	2.7 V ≤ EV _{DD0} ≤ 5.5 V, C _b = 50 pF, R _b = 2.7 kΩ		400 ^{Note1}	kHz
		2.4 V ≤ EV _{DD0} ≤ 5.5 V, C _b = 100 pF, R _b = 3 kΩ		100 ^{Note1}	kHz
Hold time when SCLr = "L"	t _{LOW}	2.7 V ≤ EV _{DD0} ≤ 5.5 V, C _b = 50 pF, R _b = 2.7 kΩ	1200		ns
		2.4 V ≤ EV _{DD0} ≤ 5.5 V, C _b = 100 pF, R _b = 3 kΩ	4600		ns
Hold time when SCLr = "H"	t _{HIGH}	2.7 V ≤ EV _{DD0} ≤ 5.5 V, C _b = 50 pF, R _b = 2.7 kΩ	1200		ns
		2.4 V ≤ EV _{DD0} ≤ 5.5 V, C _b = 100 pF, R _b = 3 kΩ	4600		ns
Data setup time (reception)	t _{SU:DAT}	2.7 V ≤ EV _{DD0} ≤ 5.5 V, C _b = 50 pF, R _b = 2.7 kΩ	1/f _{MCK} + 220 ^{Note2}		ns
		2.4 V ≤ EV _{DD0} ≤ 5.5 V, C _b = 100 pF, R _b = 3 kΩ	1/f _{MCK} + 580 ^{Note2}		ns
Data hold time (transmission)	t _{HD:DAT}	2.7 V ≤ EV _{DD0} ≤ 5.5 V, C _b = 50 pF, R _b = 2.7 kΩ	0	770	ns
		2.4 V ≤ EV _{DD0} ≤ 5.5 V, C _b = 100 pF, R _b = 3 kΩ	0	1420	ns

Notes 1. The value must also be equal to or less than f_{MCK}/4.

2. Set the f_{MCK} value to keep the hold time of SCLr = "L" and SCLr = "H".

Caution Select the normal input buffer and the N-ch open drain output (V_{DD} tolerance (for the 20- to 52-pin products)/EV_{DD} tolerance (for the 64- to 100-pin products)) mode for the SDAr pin and the normal output mode for the SCLr pin by using port input mode register g (PIMg) and port output mode register h (POMh).

(Remarks are listed on the next page.)

Simplified I²C mode connection diagram (during communication at same potential)

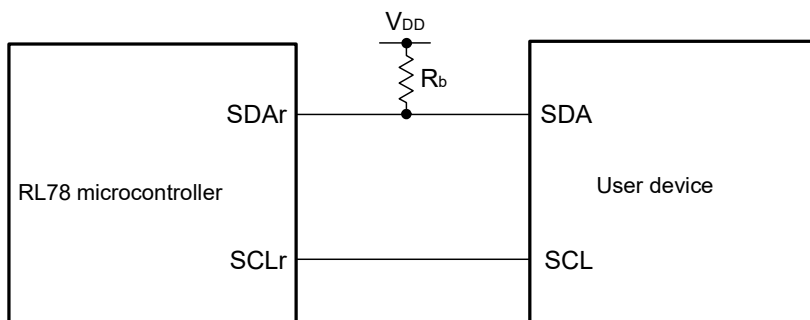

Simplified I²C mode serial transfer timing (during communication at same potential)

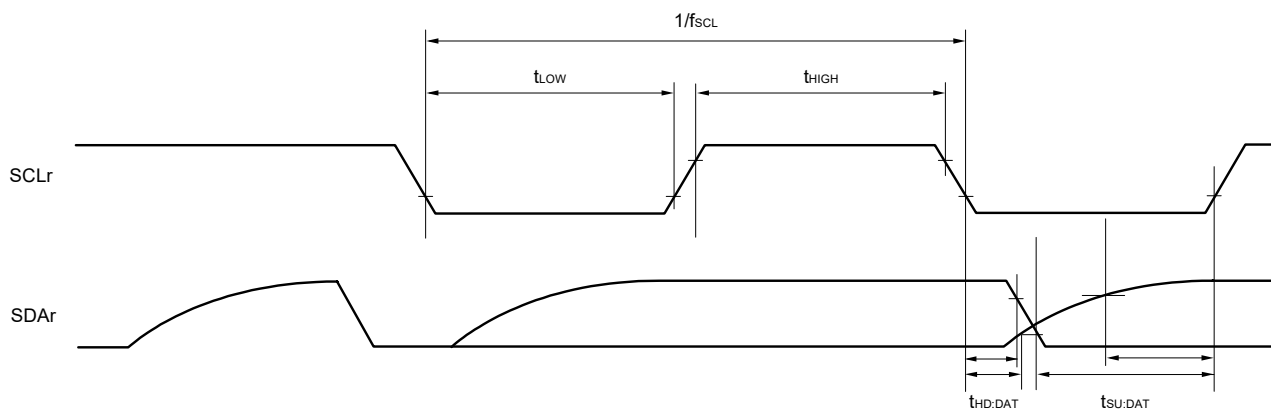

- Remarks**
1. R_b[Ω]: Communication line (SDAr) pull-up resistance, C_b[F]: Communication line (SDAr, SCLr) load capacitance
 2. r: IIC number (r = 00, 01, 10, 11, 20, 21, 30, 31), g: PIM number (g = 0, 1, 4, 5, 8, 14), h: POM number (g = 0, 1, 4, 5, 7 to 9, 14)
 3. f_{MCK}: Serial array unit operation clock frequency
(Operation clock to be set by the CKSmn bit of serial mode register mn (SMRmn). m: Unit number (m = 0, 1), n: Channel number (n = 0 to 3), mn = 00 to 03, 10 to 13)

(5) Communication at different potential (1.8 V, 2.5 V, 3 V) (UART mode) (1/2)

 (T_A = -40 to +105°C, 2.4 V ≤ EV_{DD0} = EV_{DD1} ≤ V_{DD} ≤ 5.5 V, V_{SS} = EV_{SS0} = EV_{SS1} = 0 V)

Parameter	Symbol	Conditions	HS (high-speed main) Mode		Unit	
			MIN.	MAX.		
Transfer rate		Reception	4.0 V ≤ EV _{DD0} ≤ 5.5 V, 2.7 V ≤ V _b ≤ 4.0 V		f _{MCK} /12 ^{Note 1}	bps
			Theoretical value of the maximum transfer rate f _{CLK} = 32 MHz, f _{MCK} = f _{CLK}		2.6	Mbps
			2.7 V ≤ EV _{DD0} < 4.0 V, 2.3 V ≤ V _b ≤ 2.7 V		f _{MCK} /12 ^{Note 1}	bps
			Theoretical value of the maximum transfer rate f _{CLK} = 32 MHz, f _{MCK} = f _{CLK}		2.6	Mbps
			2.4 V ≤ EV _{DD0} < 3.3 V, 1.6 V ≤ V _b ≤ 2.0 V		f _{MCK} /12 ^{Notes 1,2}	bps
			Theoretical value of the maximum transfer rate f _{CLK} = 32 MHz, f _{MCK} = f _{CLK}		2.6	Mbps

- Notes 1.** Transfer rate in the SNOOZE mode is 4800 bps only.
- 2.** The following conditions are required for low voltage interface when EV_{DD0} < V_{DD}.
2.4 V ≤ EV_{DD0} < 2.7 V : MAX. 1.3 Mbps

Caution Select the TTL input buffer for the RxDq pin and the N-ch open drain output (V_{DD} tolerance (for the 20- to 52-pin products)/EV_{DD} tolerance (for the 64- to 100-pin products)) mode for the TxDq pin by using port input mode register g (PIMg) and port output mode register g (POMg). For V_{IH} and V_{IL}, see the DC characteristics with TTL input buffer selected.

- Remarks 1.** V_b[V]: Communication line voltage
- 2.** q: UART number (q = 0 to 3), g: PIM and POM number (g = 0, 1, 8, 14)
- 3.** f_{MCK}: Serial array unit operation clock frequency
(Operation clock to be set by the CKSmn bit of serial mode register mn (SMRmn). m: Unit number, n: Channel number (mn = 00 to 03, 10 to 13))
- 4.** UART2 cannot communicate at different potential when bit 1 (PIOR1) of peripheral I/O redirection register (PIOR) is 1.

(5) Communication at different potential (1.8 V, 2.5 V, 3 V) (UART mode) (2/2)
(T_A = -40 to +105°C, 2.4 V ≤ EV_{DD0} = EV_{DD1} ≤ V_{DD} ≤ 5.5 V, V_{SS} = EV_{SS0} = EV_{SS1} = 0 V)

Parameter	Symbol	Conditions	HS (high-speed main) Mode		Unit	
			MIN.	MAX.		
Transfer rate		Transmission	4.0 V ≤ EV _{DD0} ≤ 5.5 V, 2.7 V ≤ V _b ≤ 4.0 V		Note 1	bps
			Theoretical value of the maximum transfer rate C _b = 50 pF, R _b = 1.4 kΩ, V _b = 2.7 V		2.6 ^{Note 2}	Mbps
			2.7 V ≤ EV _{DD0} < 4.0 V, 2.3 V ≤ V _b ≤ 2.7 V		Note 3	bps
			Theoretical value of the maximum transfer rate C _b = 50 pF, R _b = 2.7 kΩ, V _b = 2.3 V		1.2 ^{Note 4}	Mbps
			2.4 V ≤ EV _{DD0} < 3.3 V, 1.6 V ≤ V _b ≤ 2.0 V		Note 5	bps
			Theoretical value of the maximum transfer rate C _b = 50 pF, R _b = 5.5 kΩ, V _b = 1.6 V		0.43 ^{Note 6}	Mbps

Notes 1. The smaller maximum transfer rate derived by using f_{MCK}/12 or the following expression is the valid maximum transfer rate.

Expression for calculating the transfer rate when 4.0 V ≤ EV_{DD0} ≤ 5.5 V and 2.7 V ≤ V_b ≤ 4.0 V

$$\text{Maximum transfer rate} = \frac{1}{\{-C_b \times R_b \times \ln(1 - \frac{2.2}{V_b})\} \times 3} \text{ [bps]}$$

$$\text{Baud rate error (theoretical value)} = \frac{\frac{1}{\text{Transfer rate} \times 2} - \{-C_b \times R_b \times \ln(1 - \frac{2.2}{V_b})\}}{\left(\frac{1}{\text{Transfer rate}}\right) \times \text{Number of transferred bits}} \times 100 \text{ [%]}$$

* This value is the theoretical value of the relative difference between the transmission and reception sides.

2. This value as an example is calculated when the conditions described in the “Conditions” column are met. Refer to Note 1 above to calculate the maximum transfer rate under conditions of the customer.

3. The smaller maximum transfer rate derived by using f_{MCK}/12 or the following expression is the valid maximum transfer rate.

Expression for calculating the transfer rate when 2.7 V ≤ EV_{DD0} < 4.0 V and 2.4 V ≤ V_b ≤ 2.7 V

$$\text{Maximum transfer rate} = \frac{1}{\{-C_b \times R_b \times \ln(1 - \frac{2.0}{V_b})\} \times 3} \text{ [bps]}$$

$$\text{Baud rate error (theoretical value)} = \frac{\frac{1}{\text{Transfer rate} \times 2} - \{-C_b \times R_b \times \ln(1 - \frac{2.0}{V_b})\}}{\left(\frac{1}{\text{Transfer rate}}\right) \times \text{Number of transferred bits}} \times 100 \text{ [%]}$$

* This value is the theoretical value of the relative difference between the transmission and reception sides.

4. This value as an example is calculated when the conditions described in the “Conditions” column are met. Refer to Note 3 above to calculate the maximum transfer rate under conditions of the customer.

Notes 5. The smaller maximum transfer rate derived by using $f_{mck}/12$ or the following expression is the valid maximum transfer rate.

Expression for calculating the transfer rate when $2.4\text{ V} \leq EV_{DD0} < 3.3\text{ V}$ and $1.6\text{ V} \leq V_b \leq 2.0\text{ V}$

$$\text{Maximum transfer rate} = \frac{1}{\{-C_b \times R_b \times \ln(1 - \frac{1.5}{V_b})\} \times 3} \text{ [bps]}$$

$$\text{Baud rate error (theoretical value)} = \frac{\frac{1}{\text{Transfer rate} \times 2} - \{-C_b \times R_b \times \ln(1 - \frac{1.5}{V_b})\}}{(\frac{1}{\text{Transfer rate}}) \times \text{Number of transferred bits}} \times 100 \text{ [%]}$$

* This value is the theoretical value of the relative difference between the transmission and reception sides.

6. This value as an example is calculated when the conditions described in the “Conditions” column are met. Refer to Note 5 above to calculate the maximum transfer rate under conditions of the customer.

Caution Select the TTL input buffer for the RxDq pin and the N-ch open drain output (V_{DD} tolerance (for the 20- to 52-pin products)/EV_{DD} tolerance (for the 64- to 100-pin products)) mode for the TxDq pin by using port input mode register g (PIMg) and port output mode register g (POMg). For V_{IH} and V_{IL}, see the DC characteristics with TTL input buffer selected.

UART mode connection diagram (during communication at different potential)

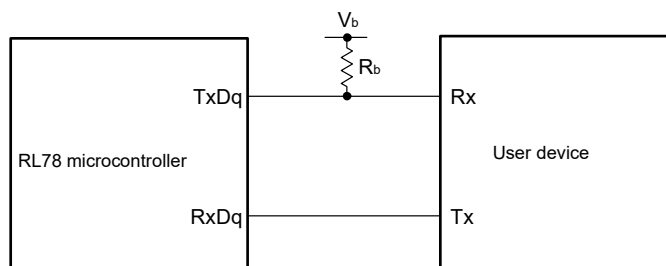

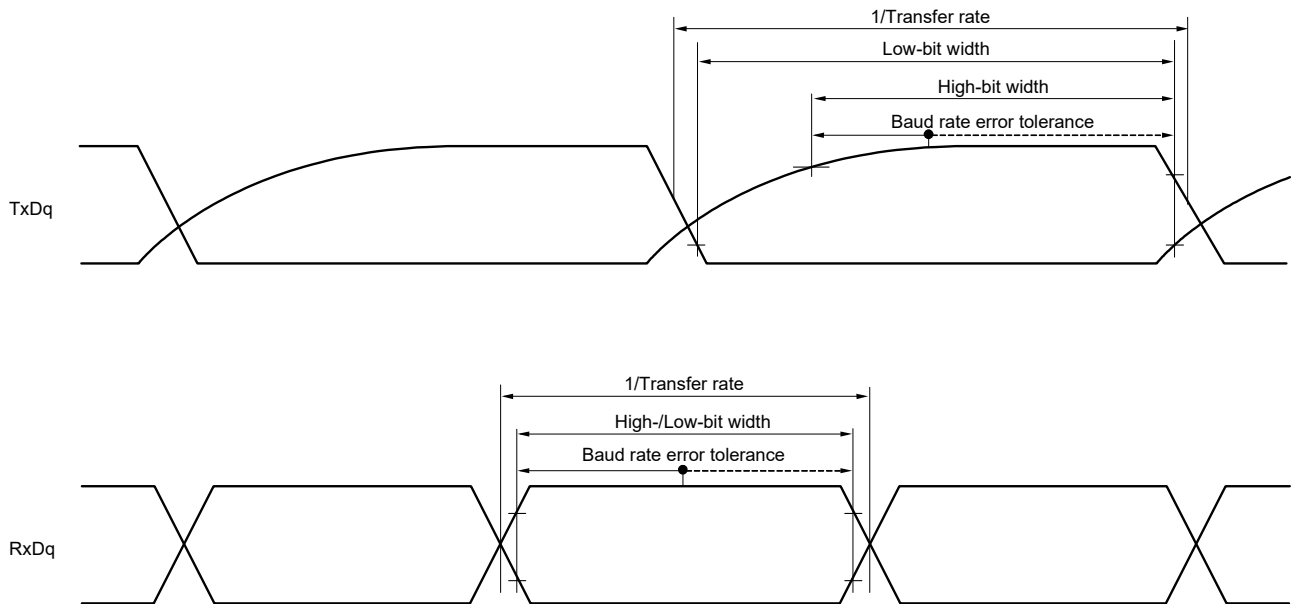
UART mode bit width (during communication at different potential) (reference)

- Remarks 1.** $R_b[\Omega]$: Communication line (TxDq) pull-up resistance,
 $C_b[F]$: Communication line (TxDq) load capacitance, $V_b[V]$: Communication line voltage
2. q: UART number (q = 0 to 3), g: PIM and POM number (g = 0, 1, 8, 14)
 3. f_{MCK} : Serial array unit operation clock frequency
 (Operation clock to be set by the CKSmn bit of serial mode register mn (SMRmn).
 m: Unit number, n: Channel number (mn = 00 to 03, 10 to 13))
 4. UART2 cannot communicate at different potential when bit 1 (PIOR1) of peripheral I/O redirection register (PIOR) is 1.

(6) Communication at different potential (1.8 V, 2.5 V, 3 V) (Simplified SPI (CSI) mode) (master mode, SCKp... internal clock output) (1/3)
(T_A = -40 to +105°C, 2.4 V ≤ EV_{DD0} = EV_{DD1} ≤ V_{DD} ≤ 5.5 V, V_{SS} = EV_{SS0} = EV_{SS1} = 0 V)

Parameter	Symbol	Conditions	HS (high-speed main) Mode		Unit
			MIN.	MAX.	
SCKp cycle time	t _{KCY1}	t _{KCY1} ≥ 4/f _{CLK} 4.0 V ≤ EV _{DD0} ≤ 5.5 V, 2.7 V ≤ V _b ≤ 4.0 V, C _b = 30 pF, R _b = 1.4 kΩ	600		ns
		2.7 V ≤ EV _{DD0} < 4.0 V, 2.3 V ≤ V _b ≤ 2.7 V, C _b = 30 pF, R _b = 2.7 kΩ	1000		ns
		2.4 V ≤ EV _{DD0} < 3.3 V, 1.6 V ≤ V _b ≤ 2.0 V, C _b = 30 pF, R _b = 5.5 kΩ	2300		ns
SCKp high-level width	t _{KH1}	4.0 V ≤ EV _{DD0} ≤ 5.5 V, 2.7 V ≤ V _b ≤ 4.0 V, C _b = 30 pF, R _b = 1.4 kΩ	t _{KCY1} /2 - 150		ns
		2.7 V ≤ EV _{DD0} < 4.0 V, 2.3 V ≤ V _b ≤ 2.7 V, C _b = 30 pF, R _b = 2.7 kΩ	t _{KCY1} /2 - 340		ns
		2.4 V ≤ EV _{DD0} < 3.3 V, 1.6 V ≤ V _b ≤ 2.0 V, C _b = 30 pF, R _b = 5.5 kΩ	t _{KCY1} /2 - 916		ns
SCKp low-level width	t _{KL1}	4.0 V ≤ EV _{DD0} ≤ 5.5 V, 2.7 V ≤ V _b ≤ 4.0 V, C _b = 30 pF, R _b = 1.4 kΩ	t _{KCY1} /2 - 24		ns
		2.7 V ≤ EV _{DD0} < 4.0 V, 2.3 V ≤ V _b ≤ 2.7 V, C _b = 30 pF, R _b = 2.7 kΩ	t _{KCY1} /2 - 36		ns
		2.4 V ≤ EV _{DD0} < 3.3 V, 1.6 V ≤ V _b ≤ 2.0 V, C _b = 30 pF, R _b = 5.5 kΩ	t _{KCY1} /2 - 100		ns

Caution Select the TTL input buffer for the SIp pin and the N-ch open drain output (V_{DD} tolerance (for the 20- to 52-pin products)/EV_{DD} tolerance (for the 64- to 100-pin products)) mode for the SOp pin and SCKp pin by using port input mode register g (PIMg) and port output mode register g (POMg). For V_{IH} and V_{IL}, see the DC characteristics with TTL input buffer selected.

(Remarks are listed two pages after the next page.)

(6) Communication at different potential (1.8 V, 2.5 V, 3 V) (Simplified SPI (CSI) mode) (master mode, SCKp... internal clock output) (2/3)
(T_A = -40 to +105°C, 2.4 V ≤ EV_{DD0} = EV_{DD1} ≤ V_{DD} ≤ 5.5 V, V_{SS} = EV_{SS0} = EV_{SS1} = 0 V)

Parameter	Symbol	Conditions	HS (high-speed main) Mode		Unit
			MIN.	MAX.	
Slp setup time (to SCKp↑) ^{Note}	t _{SIK1}	4.0 V ≤ EV _{DD0} ≤ 5.5 V, 2.7 V ≤ V _b ≤ 4.0 V, C _b = 30 pF, R _b = 1.4 kΩ	162		ns
		2.7 V ≤ EV _{DD0} < 4.0 V, 2.3 V ≤ V _b ≤ 2.7 V, C _b = 30 pF, R _b = 2.7 kΩ	354		ns
		2.4 V ≤ EV _{DD0} < 3.3 V, 1.6 V ≤ V _b ≤ 2.0 V, C _b = 30 pF, R _b = 5.5 kΩ	958		ns
Slp hold time (from SCKp↑) ^{Note}	t _{SH1}	4.0 V ≤ EV _{DD0} ≤ 5.5 V, 2.7 V ≤ V _b ≤ 4.0 V, C _b = 30 pF, R _b = 1.4 kΩ	38		ns
		2.7 V ≤ EV _{DD0} < 4.0 V, 2.3 V ≤ V _b ≤ 2.7 V, C _b = 30 pF, R _b = 2.7 kΩ	38		ns
		2.4 V ≤ EV _{DD0} < 3.3 V, 1.6 V ≤ V _b ≤ 2.0 V, C _b = 30 pF, R _b = 2.7 kΩ	38		ns
Delay time from SCKp↓ to SOp output ^{Note}	t _{KSO1}	4.0 V ≤ EV _{DD0} ≤ 5.5 V, 2.7 V ≤ V _b ≤ 4.0 V, C _b = 30 pF, R _b = 1.4 kΩ		200	ns
		2.7 V ≤ EV _{DD0} < 4.0 V, 2.3 V ≤ V _b ≤ 2.7 V, C _b = 30 pF, R _b = 2.7 kΩ		390	ns
		2.4 V ≤ EV _{DD0} < 3.3 V, 1.6 V ≤ V _b ≤ 2.0 V, C _b = 30 pF, R _b = 5.5 kΩ		966	ns

Note When DAP_{mn} = 0 and CKP_{mn} = 0, or DAP_{mn} = 1 and CKP_{mn} = 1.

Caution Select the TTL input buffer for the Slp pin and the N-ch open drain output (V_{DD} tolerance (for the 20- to 52-pin products)/EV_{DD} tolerance (for the 64- to 100-pin products)) mode for the SOp pin and SCKp pin by using port input mode register g (PIMg) and port output mode register g (POMg). For V_{IH} and V_{IL}, see the DC characteristics with TTL input buffer selected.

(Remarks are listed on the page after the next page.)

(6) Communication at different potential (1.8 V, 2.5 V, 3 V) (Simplified SPI (CSI) mode) (master mode, SCKp... internal clock output) (3/3)
(T_A = -40 to +105°C, 2.4 V ≤ EV_{DD0} = EV_{DD1} ≤ V_{DD} ≤ 5.5 V, V_{SS} = EV_{SS0} = EV_{SS1} = 0 V)

Parameter	Symbol	Conditions	HS (high-speed main) Mode		Unit
			MIN.	MAX.	
Slp setup time (to SCKp↓) ^{Note}	t _{SIK1}	4.0 V ≤ EV _{DD} ≤ 5.5 V, 2.7 V ≤ V _b ≤ 4.0 V, C _b = 30 pF, R _b = 1.4 kΩ	88		ns
		2.7 V ≤ EV _{DD0} < 4.0 V, 2.3 V ≤ V _b ≤ 2.7 V, C _b = 30 pF, R _b = 2.7 kΩ	88		ns
		2.4 V ≤ EV _{DD0} < 3.3 V, 1.6 V ≤ V _b ≤ 2.0 V, C _b = 30 pF, R _b = 5.5 kΩ	220		ns
Slp hold time (from SCKp↓) ^{Note}	t _{KS11}	4.0 V ≤ EV _{DD0} ≤ 5.5 V, 2.7 V ≤ V _b ≤ 4.0 V, C _b = 30 pF, R _b = 1.4 kΩ	38		ns
		2.7 V ≤ EV _{DD0} < 4.0 V, 2.3 V ≤ V _b ≤ 2.7 V, C _b = 30 pF, R _b = 2.7 kΩ	38		ns
		2.4 V ≤ EV _{DD0} < 3.3 V, 1.6 V ≤ V _b ≤ 2.0 V, C _b = 30 pF, R _b = 5.5 kΩ	38		ns
Delay time from SCKp↑ to SOp output ^{Note}	t _{KSO1}	4.0 V ≤ EV _{DD0} ≤ 5.5 V, 2.7 V ≤ V _b ≤ 4.0 V, C _b = 30 pF, R _b = 1.4 kΩ		50	ns
		2.7 V ≤ EV _{DD0} < 4.0 V, 2.3 V ≤ V _b ≤ 2.7 V, C _b = 30 pF, R _b = 2.7 kΩ		50	ns
		2.4 V ≤ EV _{DD0} < 3.3 V, 1.6 V ≤ V _b ≤ 2.0 V, C _b = 30 pF, R _b = 5.5 kΩ		50	ns

Note When DAP_{mn} = 0 and CKP_{mn} = 1, or DAP_{mn} = 1 and CKP_{mn} = 0.

Caution Select the TTL input buffer for the Slp pin and the N-ch open drain output (V_{DD} tolerance (for the 20- to 52-pin products)/EV_{DD} tolerance (for the 64- to 100-pin products)) mode for the SOp pin and SCKp pin by using port input mode register g (PIMg) and port output mode register g (POMg). For V_{IH} and V_{IL}, see the DC characteristics with TTL input buffer selected.

(Remarks are listed on the next page.)

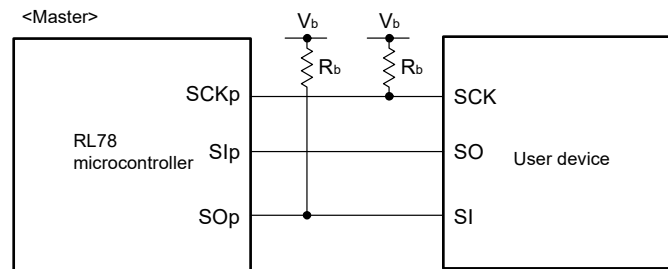
Simplified SPI (CSI) mode connection diagram (during communication at different potential)

- Remarks**
1. $R_b[\Omega]$: Communication line (SCKp, SOp) pull-up resistance, $C_b[F]$: Communication line (SCKp, SOp) load capacitance, $V_b[V]$: Communication line voltage
 2. p: CSI number (p = 00, 01, 10, 20, 30, 31), m: Unit number, n: Channel number (mn = 00, 01, 02, 10, 12, 13), g: PIM and POM number (g = 0, 1, 4, 5, 8, 14)
 3. f_{MCK} : Serial array unit operation clock frequency
(Operation clock to be set by the CKSmn bit of serial mode register mn (SMRmn).
m: Unit number, n: Channel number (mn = 00))
 4. CSI01 of 48-, 52-, 64-pin products, and CSI11 and CSI21 cannot communicate at different potential. Use other CSI for communication at different potential.

**Simplified SPI (CSI) mode serial transfer timing (master mode) (during communication at different potential)
(When DAPmn = 0 and CKPmn = 0, or DAPmn = 1 and CKPmn = 1.)**

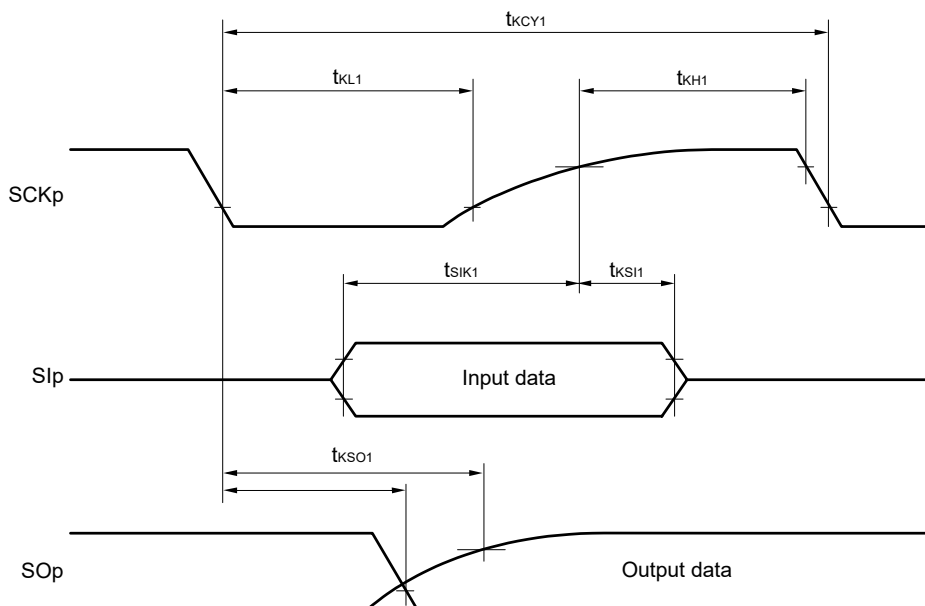

**Simplified SPI (CSI) mode serial transfer timing (master mode) (during communication at different potential)
(When DAPmn = 0 and CKPmn = 1, or DAPmn = 1 and CKPmn = 0.)**

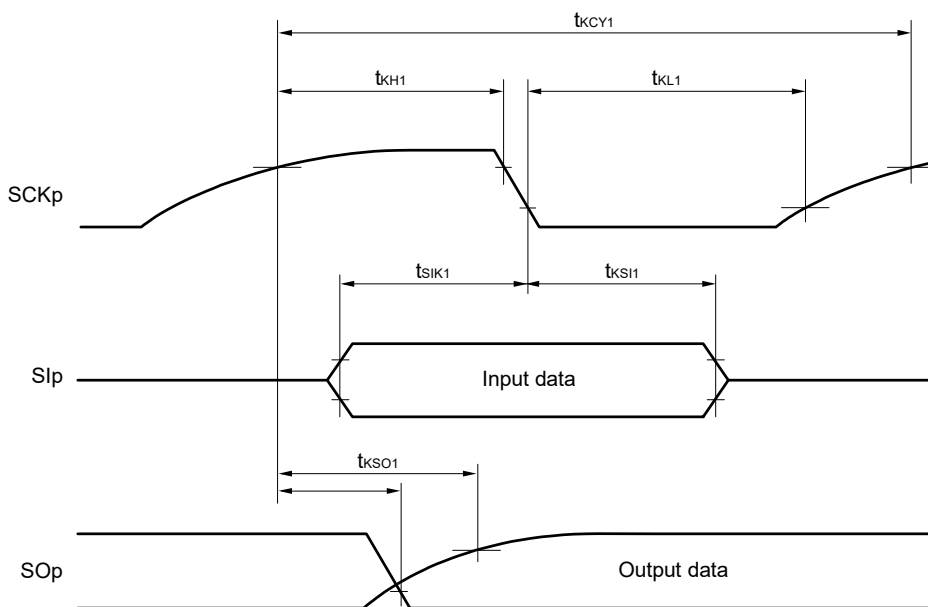

- Remarks**
1. p: CSI number (p = 00, 01, 10, 20, 30, 31), m: Unit number (m = 00, 01, 02, 10, 12, 13), n: Channel number (n = 0, 2), g: PIM and POM number (g = 0, 1, 4, 5, 8, 14)
 2. CSI01 of 48-, 52-, 64-pin products, and CSI11 and CSI21 cannot communicate at different potential. Use other CSI for communication at different potential.

(7) Communication at different potential (1.8 V, 2.5 V, 3 V) (Simplified SPI (CSI) mode) (slave mode, SCKp... external clock input)

(T_A = -40 to +105°C, 2.4 V ≤ EV_{DD0} = EV_{DD1} ≤ V_{DD} ≤ 5.5 V, V_{SS} = EV_{SS0} = EV_{SS1} = 0 V)

Parameter	Symbol	Conditions	HS (high-speed main) Mode		Unit
			MIN.	MAX.	
SCKp cycle time ^{Note 1}	t _{KCY2}	4.0 V ≤ EV _{DD0} ≤ 5.5 V, 2.7 V ≤ V _b ≤ 4.0 V	24 MHz < f _{MCK}	28/f _{MCK}	ns
			20 MHz < f _{MCK} ≤ 24 MHz	24/f _{MCK}	ns
			8 MHz < f _{MCK} ≤ 20 MHz	20/f _{MCK}	ns
			4 MHz < f _{MCK} ≤ 8 MHz	16/f _{MCK}	ns
			f _{MCK} ≤ 4 MHz	12/f _{MCK}	ns
		2.7 V ≤ EV _{DD0} < 4.0 V, 2.3 V ≤ V _b ≤ 2.7 V	24 MHz < f _{MCK}	40/f _{MCK}	ns
			20 MHz < f _{MCK} ≤ 24 MHz	32/f _{MCK}	ns
			16 MHz < f _{MCK} ≤ 20 MHz	28/f _{MCK}	ns
			8 MHz < f _{MCK} ≤ 16 MHz	24/f _{MCK}	ns
			4 MHz < f _{MCK} ≤ 8 MHz	16/f _{MCK}	ns
		2.4 V ≤ EV _{DD0} < 3.3 V, 1.6 V ≤ V _b ≤ 2.0 V	f _{MCK} ≤ 4 MHz	12/f _{MCK}	ns
			24 MHz < f _{MCK}	96/f _{MCK}	ns
			20 MHz < f _{MCK} ≤ 24 MHz	72/f _{MCK}	ns
			16 MHz < f _{MCK} ≤ 20 MHz	64/f _{MCK}	ns
			8 MHz < f _{MCK} ≤ 16 MHz	52/f _{MCK}	ns
	4 MHz < f _{MCK} ≤ 8 MHz	32/f _{MCK}	ns		
	f _{MCK} ≤ 4 MHz	20/f _{MCK}	ns		
	SCKp high-/low-level width	t _{KH2} , t _{KL2}	4.0 V ≤ EV _{DD0} ≤ 5.5 V, 2.7 V ≤ V _b ≤ 4.0 V	t _{KCY2} /2 - 24	ns
			2.7 V ≤ EV _{DD0} < 4.0 V, 2.3 V ≤ V _b ≤ 2.7 V	t _{KCY2} /2 - 36	ns
			2.4 V ≤ EV _{DD0} < 3.3 V, 1.6 V ≤ V _b ≤ 2.0 V ^{Note 2}	t _{KCY2} /2 - 100	ns
Slp setup time (to SCKp↑) ^{Note 2}	t _{SIK2}	4.0 V ≤ EV _{DD0} ≤ 5.5 V, 2.7 V ≤ V _b ≤ 4.0 V	1/f _{MCK} + 40	ns	
		2.7 V ≤ EV _{DD0} < 4.0 V, 2.3 V ≤ V _b ≤ 2.7 V	1/f _{MCK} + 40	ns	
		2.4 V ≤ EV _{DD0} < 3.3 V, 1.6 V ≤ V _b ≤ 2.0 V	1/f _{MCK} + 60	ns	
Slp hold time (from SCKp↑) ^{Note 3}	t _{KSI2}		1/f _{MCK} + 62	ns	
Delay time from SCKp↓ to SO _p output ^{Note 4}	t _{KSO2}	4.0 V ≤ EV _{DD0} ≤ 5.5 V, 2.7 V ≤ V _b ≤ 4.0 V, C _b = 30 pF, R _b = 1.4 kΩ		2/f _{MCK} + 240	ns
		2.7 V ≤ EV _{DD0} < 4.0 V, 2.3 V ≤ V _b ≤ 2.7 V, C _b = 30 pF, R _b = 2.7 kΩ		2/f _{MCK} + 428	ns
		2.4 V ≤ EV _{DD0} < 3.3 V, 1.6 V ≤ V _b ≤ 2.0 V C _b = 30 pF, R _b = 5.5 kΩ		2/f _{MCK} + 1146	ns

(Notes, Caution and Remarks are listed on the next page.)

- Notes**
1. Transfer rate in the SNOOZE mode : MAX. 1 Mbps
 2. When DAP_{mn} = 0 and CKP_{mn} = 0, or DAP_{mn} = 1 and CKP_{mn} = 1. The SIp setup time becomes “to SCKp↓” when DAP_{mn} = 0 and CKP_{mn} = 1, or DAP_{mn} = 1 and CKP_{mn} = 0.
 3. When DAP_{mn} = 0 and CKP_{mn} = 0, or DAP_{mn} = 1 and CKP_{mn} = 1. The SIp hold time becomes “from SCKp↓” when DAP_{mn} = 0 and CKP_{mn} = 1, or DAP_{mn} = 1 and CKP_{mn} = 0.
 4. When DAP_{mn} = 0 and CKP_{mn} = 0, or DAP_{mn} = 1 and CKP_{mn} = 1. The delay time to SOp output becomes “from SCKp↑” when DAP_{mn} = 0 and CKP_{mn} = 1, or DAP_{mn} = 1 and CKP_{mn} = 0.

Caution Select the TTL input buffer for the SIp pin and SCKp pin and the N-ch open drain output (V_{DD} tolerance (for the 20- to 52-pin products)/EV_{DD} tolerance (for the 64- to 128-pin products)) mode for the SOp pin by using port input mode register g (PIMg) and port output mode register g (POMg). For V_{IH} and V_{IL}, see the DC characteristics with TTL input buffer selected.

Simplified SPI (CSI) mode connection diagram (during communication at different potential)

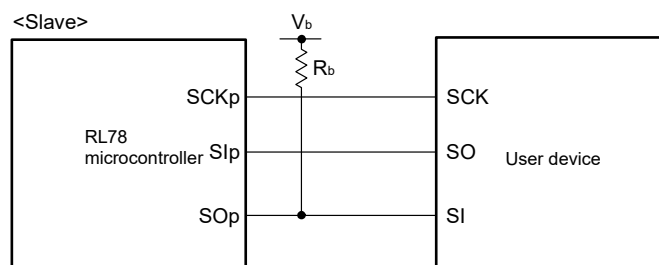

- Remarks**
1. R_b[Ω]: Communication line (SO_p) pull-up resistance, C_b[F]: Communication line (SO_p) load capacitance, V_b[V]: Communication line voltage
 2. p: CSI number (p = 00, 01, 10, 20, 30, 31), m: Unit number (m = 0, 1), n: Channel number (n = 00, 01, 02, 10, 12, 13), g: PIM and POM number (g = 0, 1, 4, 5, 8, 14)
 3. f_{MCK}: Serial array unit operation clock frequency
(Operation clock to be set by the CKS_{mn} bit of serial mode register mn (SMR_{mn}).
m: Unit number, n: Channel number (mn = 00, 01, 02, 10, 12, 13))
 4. CSI01 of 48-, 52-, 64-pin products, and CSI11 and CSI21 cannot communicate at different potential. Use other CSI for communication at different potential.

Simplified SPI (CSI) mode serial transfer timing (slave mode) (during communication at different potential)
(When DAPmn = 0 and CKPmn = 0, or DAPmn = 1 and CKPmn = 1.)

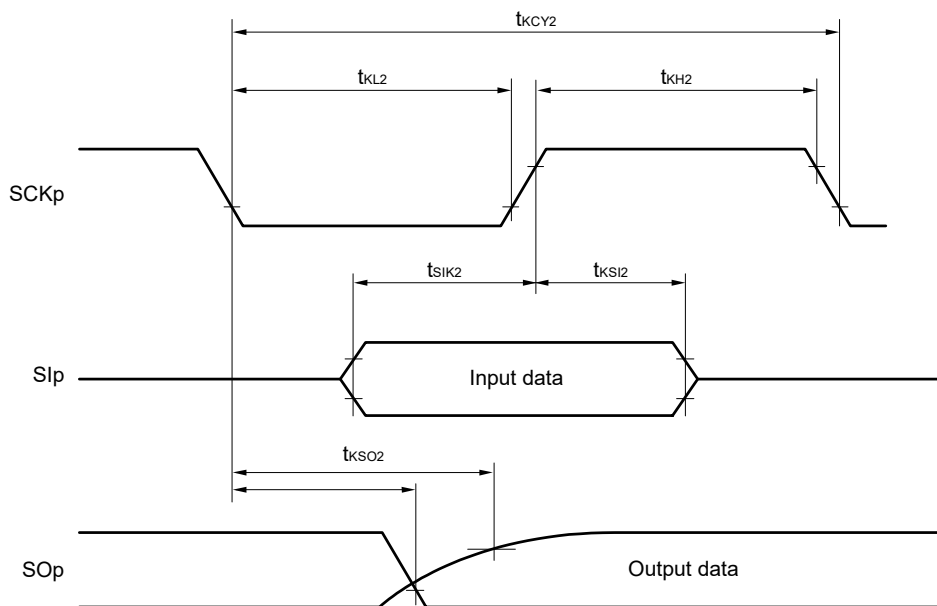

Simplified SPI (CSI) mode serial transfer timing (slave mode) (during communication at different potential)
(When DAPmn = 0 and CKPmn = 1, or DAPmn = 1 and CKPmn = 0.)

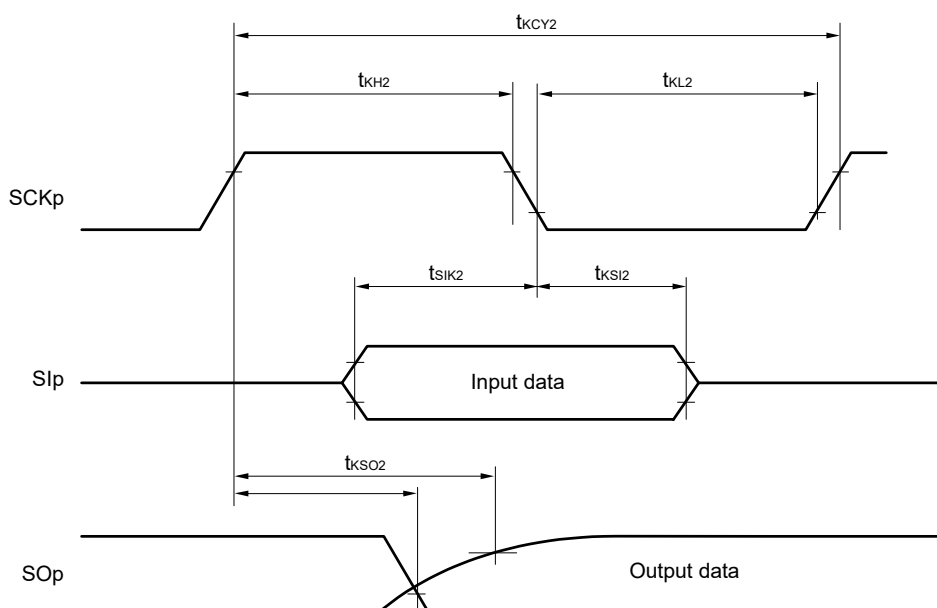

- Remarks 1.** p: CSI number (p = 00, 01, 10, 20, 30, 31), m: Unit number,
 n: Channel number (mn = 00, 01, 02, 10, 12, 13), g: PIM and POM number (g = 0, 1, 4, 5, 8, 14)
- 2.** CSI01 of 48-, 52-, 64-pin products, and CSI11 and CSI21 cannot communicate at different potential. Use other CSI for communication at different potential.

(8) Communication at different potential (1.8 V, 2.5 V, 3 V) (simplified I²C mode) (1/2)
(T_A = -40 to +105°C, 2.4 V ≤ EV_{DD0} = EV_{DD1} ≤ V_{DD} ≤ 5.5 V, V_{SS} = EV_{SS0} = EV_{SS1} = 0 V)

Parameter	Symbol	Conditions	HS (high-speed main) Mode		Unit
			MIN.	MAX.	
SCLr clock frequency	f _{SCL}	4.0 V ≤ EV _{DD0} ≤ 5.5 V, 2.7 V ≤ V _b ≤ 4.0 V, C _b = 50 pF, R _b = 2.7 kΩ		400 ^{Note 1}	kHz
		2.7 V ≤ EV _{DD0} < 4.0 V, 2.3 V ≤ V _b ≤ 2.7 V, C _b = 50 pF, R _b = 2.7 kΩ		400 ^{Note 1}	
		4.0 V ≤ EV _{DD0} ≤ 5.5 V, 2.7 V ≤ V _b ≤ 4.0 V, C _b = 100 pF, R _b = 2.8 kΩ		100 ^{Note 1}	
		2.7 V ≤ EV _{DD0} < 4.0 V, 2.3 V ≤ V _b ≤ 2.7 V, C _b = 100 pF, R _b = 2.7 kΩ		100 ^{Note 1}	
		2.4 V ≤ EV _{DD0} < 3.3 V, 1.6 V ≤ V _b ≤ 2.0 V, C _b = 100 pF, R _b = 5.5 kΩ		100 ^{Note 1}	
Hold time when SCLr = "L"	t _{LOW}	4.0 V ≤ EV _{DD0} ≤ 5.5 V, 2.7 V ≤ V _b ≤ 4.0 V, C _b = 50 pF, R _b = 2.7 kΩ	1200		ns
		2.7 V ≤ EV _{DD0} < 4.0 V, 2.3 V ≤ V _b ≤ 2.7 V, C _b = 50 pF, R _b = 2.7 kΩ	1200		
		4.0 V ≤ EV _{DD0} ≤ 5.5 V, 2.7 V ≤ V _b ≤ 4.0 V, C _b = 100 pF, R _b = 2.8 kΩ	4600		
		2.7 V ≤ EV _{DD0} < 4.0 V, 2.3 V ≤ V _b ≤ 2.7 V, C _b = 100 pF, R _b = 2.7 kΩ	4600		
		2.4 V ≤ EV _{DD0} < 3.3 V, 1.6 V ≤ V _b ≤ 2.0 V, C _b = 100 pF, R _b = 5.5 kΩ	4650		
Hold time when SCLr = "H"	t _{HIGH}	4.0 V ≤ EV _{DD0} ≤ 5.5 V, 2.7 V ≤ V _b ≤ 4.0 V, C _b = 50 pF, R _b = 2.7 kΩ	620		ns
		2.7 V ≤ EV _{DD0} < 4.0 V, 2.3 V ≤ V _b ≤ 2.7 V, C _b = 50 pF, R _b = 2.7 kΩ	500		
		4.0 V ≤ EV _{DD0} ≤ 5.5 V, 2.7 V ≤ V _b ≤ 4.0 V, C _b = 100 pF, R _b = 2.8 kΩ	2700		
		2.7 V ≤ EV _{DD0} < 4.0 V, 2.3 V ≤ V _b ≤ 2.7 V, C _b = 100 pF, R _b = 2.7 kΩ	2400		
		2.4 V ≤ EV _{DD0} < 3.3 V, 1.6 V ≤ V _b ≤ 2.0 V, C _b = 100 pF, R _b = 5.5 kΩ	1830		

(Notes and Caution are listed on the next page, and Remarks are listed on the page after the next page.)

(8) Communication at different potential (1.8 V, 2.5 V, 3 V) (simplified I²C mode) (2/2)
(T_A = -40 to +105°C, 2.4 V ≤ EV_{DD0} = EV_{DD1} ≤ V_{DD} ≤ 5.5 V, V_{SS} = EV_{SS0} = EV_{SS1} = 0 V)

Parameter	Symbol	Conditions	HS (high-speed main) Mode		Unit
			MIN.	MAX.	
Data setup time (reception)	t _{SU:DAT}	4.0 V ≤ EV _{DD0} ≤ 5.5 V, 2.7 V ≤ V _b ≤ 4.0 V, C _b = 50 pF, R _b = 2.7 kΩ	1/f _{MCK} + 340 Note 2		ns
		2.7 V ≤ EV _{DD0} < 4.0 V, 2.3 V ≤ V _b ≤ 2.7 V, C _b = 50 pF, R _b = 2.7 kΩ	1/f _{MCK} + 340 Note 2		ns
		4.0 V ≤ EV _{DD0} ≤ 5.5 V, 2.7 V ≤ V _b ≤ 4.0 V, C _b = 100 pF, R _b = 2.8 kΩ	1/f _{MCK} + 760 Note 2		ns
		2.7 V ≤ EV _{DD0} < 4.0 V, 2.3 V ≤ V _b ≤ 2.7 V, C _b = 100 pF, R _b = 2.7 kΩ	1/f _{MCK} + 760 Note 2		ns
		2.4 V ≤ EV _{DD0} < 3.3 V, 1.6 V ≤ V _b ≤ 2.0 V, C _b = 100 pF, R _b = 5.5 kΩ	1/f _{MCK} + 570 Note 2		ns
Data hold time (transmission)	t _{HD:DAT}	4.0 V ≤ EV _{DD0} ≤ 5.5 V, 2.7 V ≤ V _b ≤ 4.0 V, C _b = 50 pF, R _b = 2.7 kΩ	0	770	ns
		2.7 V ≤ EV _{DD0} < 4.0 V, 2.3 V ≤ V _b ≤ 2.7 V, C _b = 50 pF, R _b = 2.7 kΩ	0	770	ns
		4.0 V ≤ EV _{DD0} ≤ 5.5 V, 2.7 V ≤ V _b ≤ 4.0 V, C _b = 100 pF, R _b = 2.8 kΩ	0	1420	ns
		2.7 V ≤ EV _{DD0} < 4.0 V, 2.3 V ≤ V _b ≤ 2.7 V, C _b = 100 pF, R _b = 2.7 kΩ	0	1420	ns
		2.4 V ≤ EV _{DD0} < 3.3 V, 1.6 V ≤ V _b ≤ 2.0 V, C _b = 100 pF, R _b = 5.5 kΩ	0	1215	ns

Notes 1. The value must also be equal to or less than f_{MCK}/4.

2. Set the f_{MCK} value to keep the hold time of SCLr = "L" and SCLr = "H".

Caution Select the TTL input buffer and the N-ch open drain output (V_{DD} tolerance (for the 20- to 52-pin products)/EV_{DD} tolerance (for the 64- to 100-pin products)) mode for the SDAr pin and the N-ch open drain output (V_{DD} tolerance (for the 20- to 52-pin products)/EV_{DD} tolerance (for the 64- to 100-pin products)) mode for the SCLr pin by using port input mode register g (PIMg) and port output mode register g (POMg). For V_{IH} and V_{IL}, see the DC characteristics with TTL input buffer selected.

(Remarks are listed on the next page.)

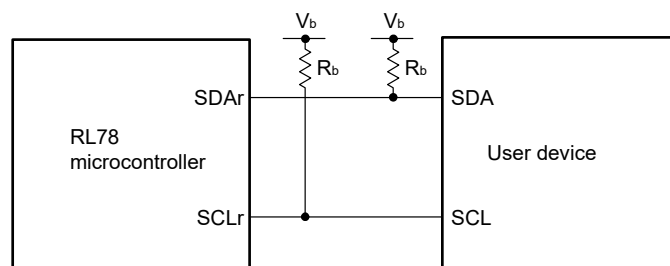
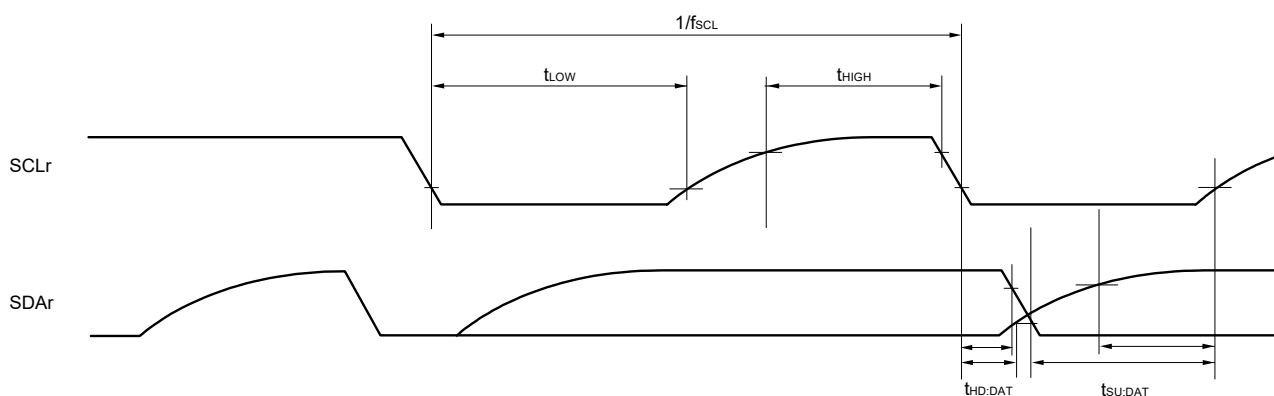
Simplified I²C mode connection diagram (during communication at different potential)**Simplified I²C mode serial transfer timing (during communication at different potential)**

Caution Select the TTL input buffer and the N-ch open drain output (V_{DD} tolerance (for the 20- to 52-pin products)/ EV_{DD} tolerance (for the 64- to 100-pin products)) mode for the SDAr pin and the N-ch open drain output (V_{DD} tolerance (for the 20- to 52-pin products)/ EV_{DD} tolerance (for the 64- to 100-pin products)) mode for the SCLr pin by using port input mode register g (PIMg) and port output mode register g (POMg). For V_{IH} and V_{IL} , see the DC characteristics with TTL input buffer selected.

- Remarks**
- $R_b[\Omega]$: Communication line (SDAr, SCLr) pull-up resistance, $C_b[F]$: Communication line (SDAr, SCLr) load capacitance, $V_b[V]$: Communication line voltage
 - r: IIC number (r = 00, 01, 10, 20, 30, 31), g: PIM, POM number (g = 0, 1, 4, 5, 8, 14)
 - f_{MCK} : Serial array unit operation clock frequency
(Operation clock to be set by the CKSmn bit of serial mode register mn (SMRmn). m: Unit number, n: Channel number (mn = 00, 01, 02, 10, 12, 13))

30.5.2 Serial interface IICA

(T_A = -40 to +105°C, 2.4 V ≤ EV_{DD0} = EV_{DD1} ≤ V_{DD} ≤ 5.5 V, V_{SS} = EV_{SS0} = EV_{SS1} = 0 V)

Parameter	Symbol	Conditions	HS (high-speed main) Mode				Unit
			Standard Mode		Fast Mode		
			MIN.	MAX.	MIN.	MAX.	
SCLA0 clock frequency	f _{SCL}	Fast mode: f _{CLK} ≥ 3.5 MHz	–	–	0	400	kHz
		Standard mode: f _{CLK} ≥ 1 MHz	0	100	–	–	kHz
Setup time of restart condition	t _{SU:STA}		4.7		0.6		μs
Hold time ^{Note 1}	t _{HD:STA}		4.0		0.6		μs
Hold time when SCLA0 = "L"	t _{LOW}		4.7		1.3		μs
Hold time when SCLA0 = "H"	t _{HIGH}		4.0		0.6		μs
Data setup time (reception)	t _{SU:DAT}		250		100		ns
Data hold time (transmission) ^{Note 2}	t _{HD:DAT}		0	3.45	0	0.9	μs
Setup time of stop condition	t _{SU:STO}		4.0		0.6		μs
Bus-free time	t _{BUF}		4.7		1.3		μs

- Notes**
- The first clock pulse is generated after this period when the start/restart condition is detected.
 - The maximum value (MAX.) of t_{HD:DAT} is during normal transfer and a clock stretch state is inserted in the ACK (acknowledge) timing.

Caution The values in the above table are applied even when bit 2 (PIOR2) in the peripheral I/O redirection register (PIOR) is 1. At this time, the pin characteristics (I_{OH1}, I_{OL1}, V_{OH1}, V_{OL1}) must satisfy the values in the redirect destination.

Remark The maximum value of C_b (communication line capacitance) and the value of R_b (communication line pull-up resistor) at that time in each mode are as follows.

Standard mode: C_b = 400 pF, R_b = 2.7 kΩ
 Fast mode: C_b = 320 pF, R_b = 1.1 kΩ

IICA serial transfer timing

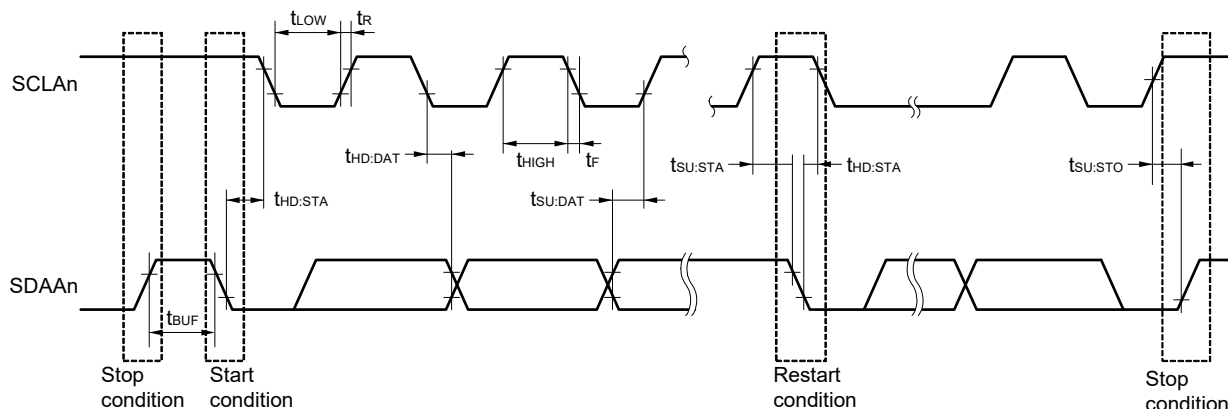

Remark n = 0, 1

30.6 Analog Characteristics

30.6.1 A/D converter characteristics

Classification of A/D converter characteristics

Input channel	Reference Voltage		
	Reference voltage (+) = AV _{REFP} Reference voltage (-) = AV _{REFM}	Reference voltage (+) = V _{DD} Reference voltage (-) = V _{SS}	Reference voltage (+) = V _{BGR} Reference voltage (-) = AV _{REFM}
ANI0 to ANI14	Refer to 30.6.1 (1) .	Refer to 30.6.1 (3) .	Refer to 30.6.1 (4) .
ANI16 to ANI26			
Internal reference voltage Temperature sensor output voltage	Refer to 30.6.1 (1) .		–

(1) When reference voltage (+) = AV_{REFP}/ANI0 (ADREFP1 = 0, ADREFP0 = 1), reference voltage (-) = AV_{REFM}/ANI1 (ADREFM = 1), target pin : ANI2 to ANI14, internal reference voltage, and temperature sensor output voltage

(T_A = -40 to +105°C, 2.4 V ≤ AV_{REFP} ≤ V_{DD} ≤ 5.5 V, V_{SS} = 0 V, Reference voltage (+) = AV_{REFP}, Reference voltage (-) = AV_{REFM} = 0 V)

Parameter	Symbol	Conditions	MIN.	TYP.	MAX.	Unit	
Resolution	RES		8		10	bit	
Overall error ^{Note 1}	AINL	10-bit resolution AV _{REFP} = V _{DD} ^{Note 3}	2.4 V ≤ AV _{REFP} ≤ 5.5 V		1.2	±3.5 LSB	
Conversion time	t _{CONV}	10-bit resolution Target pin: ANI2 to ANI14	3.6 V ≤ V _{DD} ≤ 5.5 V	2.125		39	μs
			2.7 V ≤ V _{DD} ≤ 5.5 V	3.1875		39	μs
			2.4 V ≤ V _{DD} ≤ 5.5 V	17		39	μs
		10-bit resolution Target pin: Internal reference voltage, and temperature sensor output voltage (HS (high-speed main) mode)	3.6 V ≤ V _{DD} ≤ 5.5 V	2.375		39	μs
			2.7 V ≤ V _{DD} ≤ 5.5 V	3.5625		39	μs
			2.4 V ≤ V _{DD} ≤ 5.5 V	17		39	μs
Zero-scale error ^{Notes 1, 2}	E _{ZS}	10-bit resolution AV _{REFP} = V _{DD} ^{Note 3}	2.4 V ≤ AV _{REFP} ≤ 5.5 V			±0.25 %FSR	
Full-scale error ^{Notes 1, 2}	E _{FS}	10-bit resolution AV _{REFP} = V _{DD} ^{Note 3}	2.4 V ≤ AV _{REFP} ≤ 5.5 V			±0.25 %FSR	
Integral linearity error ^{Note 1}	I _{LE}	10-bit resolution AV _{REFP} = V _{DD} ^{Note 3}	2.4 V ≤ AV _{REFP} ≤ 5.5 V			±2.5 LSB	
Differential linearity error ^{Note 1}	D _{LE}	10-bit resolution AV _{REFP} = V _{DD} ^{Note 3}	2.4 V ≤ AV _{REFP} ≤ 5.5 V			±1.5 LSB	
Analog input voltage	V _{AIN}	ANI2 to ANI14	0		AV _{REFP}	V	
		Internal reference voltage output (2.4 V ≤ V _{DD} ≤ 5.5 V, HS (high-speed main) mode)			V _{BGR} ^{Note 4}	V	
		Temperature sensor output voltage (2.4 V ≤ V _{DD} ≤ 5.5 V, HS (high-speed main) mode)			V _{TMPS25} ^{Note 4}	V	

(Notes are listed on the next page.)

- Notes**
1. Excludes quantization error ($\pm 1/2$ LSB).
 2. This value is indicated as a ratio (%FSR) to the full-scale value.
 3. When $AV_{REFP} < V_{DD}$, the MAX. values are as follows.
Overall error: Add ± 1.0 LSB to the MAX. value when $AV_{REFP} = V_{DD}$.
Zero-scale error/Full-scale error: Add $\pm 0.05\%$ FSR to the MAX. value when $AV_{REFP} = V_{DD}$.
Integral linearity error/ Differential linearity error: Add ± 0.5 LSB to the MAX. value when $AV_{REFP} = V_{DD}$.
 4. Refer to **30.6.2 Temperature sensor/internal reference voltage characteristics**.

(2) When reference voltage (+) = $AV_{REFP}/ANI0$ ($ADREFP1 = 0$, $ADREFP0 = 1$), reference voltage (-) = $AV_{REFM}/ANI1$ ($ADREFM = 1$), target pin : ANI16 to ANI26

($T_A = -40$ to $+105^\circ\text{C}$, $2.4\text{ V} \leq EV_{DD0} = EV_{DD1} \leq V_{DD} \leq 5.5\text{ V}$, $2.4\text{ V} \leq AV_{REFP} \leq V_{DD} \leq 5.5\text{ V}$, $V_{SS} = EV_{SS0} = EV_{SS1} = 0\text{ V}$, Reference voltage (+) = AV_{REFP} , Reference voltage (-) = $AV_{REFM} = 0\text{ V}$)

Parameter	Symbol	Conditions	MIN.	TYP.	MAX.	Unit
Resolution	RES		8		10	bit
Overall error ^{Note 1}	AINL	10-bit resolution $EV_{DD0} \leq AV_{REFP} = V_{DD}$ Notes 3, 4	$2.4\text{ V} \leq AV_{REFP} \leq 5.5\text{ V}$	1.2	± 5.0	LSB
Conversion time	t_{CONV}	10-bit resolution Target pin : ANI16 to ANI26	$3.6\text{ V} \leq V_{DD} \leq 5.5\text{ V}$	2.125	39	μs
			$2.7\text{ V} \leq V_{DD} \leq 5.5\text{ V}$	3.1875	39	μs
			$2.4\text{ V} \leq V_{DD} \leq 5.5\text{ V}$	17	39	μs
Zero-scale error ^{Notes 1, 2}	E _{ZS}	10-bit resolution $EV_{DD0} \leq AV_{REFP} = V_{DD}$ Notes 3, 4	$2.4\text{ V} \leq AV_{REFP} \leq 5.5\text{ V}$		± 0.35	%FSR
Full-scale error ^{Notes 1, 2}	E _{FS}	10-bit resolution $EV_{DD0} \leq AV_{REFP} = V_{DD}$ Notes 3, 4	$2.4\text{ V} \leq AV_{REFP} \leq 5.5\text{ V}$		± 0.35	%FSR
Integral linearity error ^{Note 1}	ILE	10-bit resolution $EV_{DD0} \leq AV_{REFP} = V_{DD}$ Notes 3, 4	$2.4\text{ V} \leq AV_{REFP} \leq 5.5\text{ V}$		± 3.5	LSB
Differential linearity error ^{Note 1}	DLE	10-bit resolution $EV_{DD0} \leq AV_{REFP} = V_{DD}$ Notes 3, 4	$2.4\text{ V} \leq AV_{REFP} \leq 5.5\text{ V}$		± 2.0	LSB
Analog input voltage	V _{AIN}	ANI16 to ANI26	0		AV_{REFP} and EV_{DD0}	V

Notes 1. Excludes quantization error ($\pm 1/2$ LSB).

2. This value is indicated as a ratio (%FSR) to the full-scale value.

3. When $AV_{REFP} < V_{DD}$, the MAX. values are as follows.

Overall error: Add ± 1.0 LSB to the MAX. value when $AV_{REFP} = V_{DD}$.

Zero-scale error/Full-scale error: Add $\pm 0.05\%$ FSR to the MAX. value when $AV_{REFP} = V_{DD}$.

Integral linearity error/ Differential linearity error: Add ± 0.5 LSB to the MAX. value when $AV_{REFP} = V_{DD}$.

4. When $AV_{REFP} < EV_{DD0} \leq V_{DD}$, the MAX. values are as follows.

Overall error: Add ± 4.0 LSB to the MAX. value when $AV_{REFP} = V_{DD}$.

Zero-scale error/Full-scale error: Add $\pm 0.20\%$ FSR to the MAX. value when $AV_{REFP} = V_{DD}$.

Integral linearity error/ Differential linearity error: Add ± 2.0 LSB to the MAX. value when $AV_{REFP} = V_{DD}$.

(3) When reference voltage (+) = V_{DD} (ADREFP1 = 0, ADREFP0 = 0), reference voltage (-) = V_{SS} (ADREFM = 0), target pin : ANI0 to ANI14, ANI16 to ANI26, internal reference voltage, and temperature sensor output voltage

(T_A = -40 to +105°C, 2.4 V ≤ EV_{DD0} = EV_{DD1} ≤ V_{DD} ≤ 5.5 V, V_{SS} = EV_{SS0} = EV_{SS1} = 0 V, Reference voltage (+) = V_{DD}, Reference voltage (-) = V_{SS})

Parameter	Symbol	Conditions		MIN.	TYP.	MAX.	Unit	
Resolution	RES			8		10	bit	
Overall error ^{Note 1}	AINL	10-bit resolution	2.4 V ≤ V _{DD} ≤ 5.5 V		1.2	±7.0	LSB	
Conversion time	t _{CONV}	10-bit resolution Target pin: ANI0 to ANI14, ANI16 to ANI26	3.6 V ≤ V _{DD} ≤ 5.5 V	2.125		39	μs	
			2.7 V ≤ V _{DD} ≤ 5.5 V	3.1875		39	μs	
			2.4 V ≤ V _{DD} ≤ 5.5 V	17		39	μs	
		10-bit resolution Target pin: Internal reference voltage, and temperature sensor output voltage (HS (high-speed main) mode)	3.6 V ≤ V _{DD} ≤ 5.5 V	2.375		39	μs	
			2.7 V ≤ V _{DD} ≤ 5.5 V	3.5625		39	μs	
			2.4 V ≤ V _{DD} ≤ 5.5 V	17		39	μs	
Zero-scale error ^{Notes 1, 2}	E _{ZS}	10-bit resolution	2.4 V ≤ V _{DD} ≤ 5.5 V			±0.60	%FSR	
Full-scale error ^{Notes 1, 2}	E _{FS}	10-bit resolution	2.4 V ≤ V _{DD} ≤ 5.5 V			±0.60	%FSR	
Integral linearity error ^{Note 1}	ILE	10-bit resolution	2.4 V ≤ V _{DD} ≤ 5.5 V			±4.0	LSB	
Differential linearity error ^{Note 1}	DLE	10-bit resolution	2.4 V ≤ V _{DD} ≤ 5.5 V			±2.0	LSB	
Analog input voltage	V _{AIN}	ANI0 to ANI14		0		V _{DD}	V	
		ANI16 to ANI26		0		EV _{DD0}	V	
		Internal reference voltage output (2.4 V ≤ V _{DD} ≤ 5.5 V, HS (high-speed main) mode)		V _{BGR} ^{Note 3}				V
		Temperature sensor output voltage (2.4 V ≤ V _{DD} ≤ 5.5 V, HS (high-speed main) mode)		V _{TMPS25} ^{Note 3}				V

Notes 1. Excludes quantization error (±1/2 LSB).

2. This value is indicated as a ratio (%FSR) to the full-scale value.

3. Refer to **30.6.2 Temperature sensor/internal reference voltage characteristics**.

(4) When reference voltage (+) = Internal reference voltage (ADREFP1 = 1, ADREFP0 = 0), reference voltage (-) = AV_{REFM}/ANI1 (ADREFM = 1), target pin : ANI0, ANI2 to ANI14, ANI16 to ANI26

(T_A = -40 to +105°C, 2.4 V ≤ EV_{DD0} = EV_{DD1} ≤ V_{DD} ≤ 5.5 V, V_{SS} = EV_{SS0} = EV_{SS1} = 0 V, Reference voltage (+) = V_{BGR} ^{Note 3}, Reference voltage (-) = AV_{REFM} ^{Note 4} = 0 V, HS (high-speed main) mode)

Parameter	Symbol	Conditions		MIN.	TYP.	MAX.	Unit
Resolution	RES			8			bit
Conversion time	t _{CONV}	8-bit resolution	2.4 V ≤ V _{DD} ≤ 5.5 V	17		39	μs
Zero-scale error ^{Notes 1, 2}	E _{zs}	8-bit resolution	2.4 V ≤ V _{DD} ≤ 5.5 V			±0.60	%FSR
Integral linearity error ^{Note 1}	ILE	8-bit resolution	2.4 V ≤ V _{DD} ≤ 5.5 V			±2.0	LSB
Differential linearity error ^{Note 1}	DLE	8-bit resolution	2.4 V ≤ V _{DD} ≤ 5.5 V			±1.0	LSB
Analog input voltage	V _{AIN}			0		V _{BGR} ^{Note 3}	V

Notes 1. Excludes quantization error (±1/2 LSB).

2. This value is indicated as a ratio (%FSR) to the full-scale value.

3. Refer to **30.6.2 Temperature sensor/internal reference voltage characteristics**.

4. When reference voltage (-) = V_{SS}, the MAX. values are as follows.

Zero-scale error: Add ±0.35%FSR to the MAX. value when reference voltage (-) = AV_{REFM}.

Integral linearity error: Add ±0.5 LSB to the MAX. value when reference voltage (-) = AV_{REFM}.

Differential linearity error: Add ±0.2 LSB to the MAX. value when reference voltage (-) = AV_{REFM}.

30.6.2 Temperature sensor/internal reference voltage characteristics

($T_A = -40$ to $+105^\circ\text{C}$, $2.4\text{ V} \leq V_{DD} \leq 5.5\text{ V}$, $V_{SS} = 0\text{ V}$, HS (high-speed main) mode)

Parameter	Symbol	Conditions	MIN.	TYP.	MAX.	Unit
Temperature sensor output voltage	V_{TSPS25}	Setting ADS register = 80H, $T_A = +25^\circ\text{C}$		1.05		V
Internal reference voltage	V_{BGR}	Setting ADS register = 81H	1.38	1.45	1.5	V
Temperature coefficient	F_{VTSPS}	Temperature sensor that depends on the temperature		-3.6		mV/ $^\circ\text{C}$
Operation stabilization wait time	t_{AMP}		5			μs

30.6.3 POR circuit characteristics

($T_A = -40$ to $+105^\circ\text{C}$, $V_{SS} = 0\text{ V}$)

Parameter	Symbol	Conditions	MIN.	TYP.	MAX.	Unit
Detection voltage	V_{POR}	The power supply voltage is rising.	1.45	1.51	1.57	V
	V_{PDR}	The power supply voltage is falling.	1.44	1.50	1.56	V
Minimum pulse width ^{Note}	T_{PW}		300			μs

Note Minimum time required for a POR reset when V_{DD} exceeds below V_{PDR} . This is also the minimum time required for a POR reset from when V_{DD} exceeds below 0.7 V to when V_{DD} exceeds V_{POR} while STOP mode is entered or the main system clock is stopped through setting bit 0 (HIOSTOP) and bit 7 (MSTOP) in the clock operation status control register (CSC).

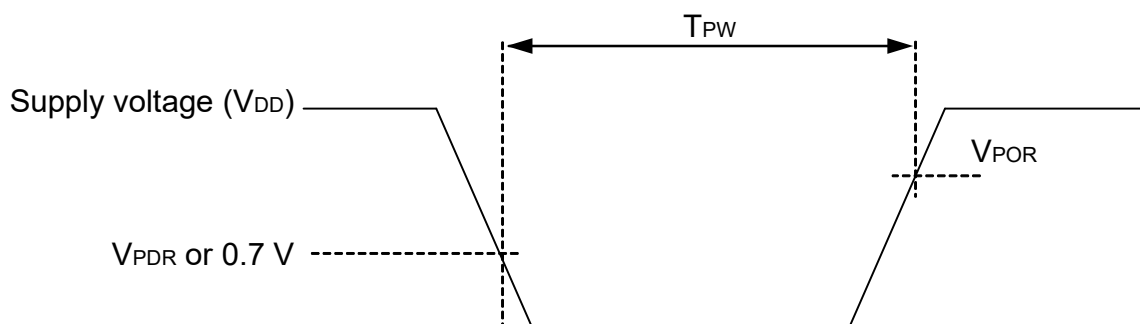

30.6.4 LVD circuit characteristics

LVD Detection Voltage of Reset Mode and Interrupt Mode

($T_A = -40$ to $+105^\circ\text{C}$, $V_{PDR} \leq V_{DD} \leq 5.5$ V, $V_{SS} = 0$ V)

Parameter		Symbol	Conditions	MIN.	TYP.	MAX.	Unit	
Detection voltage	Supply voltage level	V_{LVD0}	The power supply voltage is rising.	3.90	4.06	4.22	V	
			The power supply voltage is falling.	3.83	3.98	4.13	V	
		V_{LVD1}	The power supply voltage is rising.	3.60	3.75	3.90	V	
			The power supply voltage is falling.	3.53	3.67	3.81	V	
		V_{LVD2}	The power supply voltage is rising.	3.01	3.13	3.25	V	
			The power supply voltage is falling.	2.94	3.06	3.18	V	
		V_{LVD3}	The power supply voltage is rising.	2.90	3.02	3.14	V	
			The power supply voltage is falling.	2.85	2.96	3.07	V	
		V_{LVD4}	The power supply voltage is rising.	2.81	2.92	3.03	V	
			The power supply voltage is falling.	2.75	2.86	2.97	V	
		V_{LVD5}	The power supply voltage is rising.	2.70	2.81	2.92	V	
			The power supply voltage is falling.	2.64	2.75	2.86	V	
		V_{LVD6}	The power supply voltage is rising.	2.61	2.71	2.81	V	
			The power supply voltage is falling.	2.55	2.65	2.75	V	
		V_{LVD7}	The power supply voltage is rising.	2.51	2.61	2.71	V	
			The power supply voltage is falling.	2.45	2.55	2.65	V	
		Minimum pulse width	t_{LW}		300			μs
		Detection delay time					300	μs

LVD Detection Voltage of Interrupt & Reset Mode

($T_A = -40$ to $+105^\circ\text{C}$, $V_{PDR} \leq V_{DD} \leq 5.5$ V, $V_{SS} = 0$ V)

Parameter	Symbol	Conditions	MIN.	TYP.	MAX.	Unit		
Interrupt and reset mode	V_{LVDD0}	$V_{POC2}, V_{POC1}, V_{POC0} = 0, 1, 1$, falling reset voltage		2.64	2.75	2.86	V	
	V_{LVDD1}		LVIS1, LVIS0 = 1, 0	Rising release reset voltage	2.81	2.92	3.03	V
				Falling interrupt voltage	2.75	2.86	2.97	V
	V_{LVDD2}		LVIS1, LVIS0 = 0, 1	Rising release reset voltage	2.90	3.02	3.14	V
				Falling interrupt voltage	2.85	2.96	3.07	V
	V_{LVDD3}		LVIS1, LVIS0 = 0, 0	Rising release reset voltage	3.90	4.06	4.22	V
Falling interrupt voltage		3.83		3.98	4.13	V		

30.6.5 Power supply voltage rising slope characteristics

($T_A = -40$ to $+105^\circ\text{C}$, $V_{SS} = 0$ V)

Parameter	Symbol	Conditions	MIN.	TYP.	MAX.	Unit
Power supply voltage rising slope	S_{VDD}				54	V/ms

Caution Make sure to keep the internal reset state by the LVD circuit or an external reset until V_{DD} reaches the operating voltage range shown in 30.4 AC Characteristics.

30.7 RAM Data Retention Characteristics

(T_A = -40 to +105°C, V_{SS} = 0 V)

Parameter	Symbol	Conditions	MIN.	TYP.	MAX.	Unit
Data retention supply voltage	V _{DDDR}		1.44 ^{Note}		5.5	V

Note This depends on the POR detection voltage. For a falling voltage, data in RAM are retained until the voltage reaches the level that triggers a POR reset but not once it reaches the level at which a POR reset is generated.

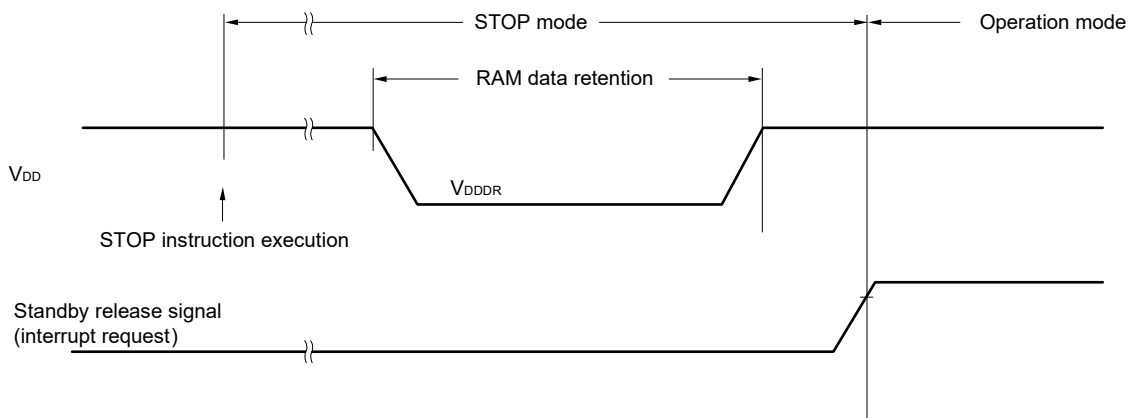

30.8 Flash Memory Programming Characteristics

(T_A = -40 to +105°C, 2.4 V ≤ V_{DD} ≤ 5.5 V, V_{SS} = 0 V)

Parameter	Symbol	Conditions	MIN.	TYP.	MAX.	Unit
CPU/peripheral hardware clock frequency	f _{CLK}	2.4 V ≤ V _{DD} ≤ 5.5 V	1		32	MHz
Number of code flash rewrites <small>Notes 1, 2, 3</small>	C _{enwr}	Retained for 20 years T _A = 85°C ^{Note 4}	1,000			Times
Number of data flash rewrites <small>Notes 1, 2, 3</small>		Retained for 1 years T _A = 25°C		1,000,000		
		Retained for 5 years T _A = 85°C ^{Note 4}	100,000			
		Retained for 20 years T _A = 85°C ^{Note 4}	10,000			

- Notes**
- 1 erase + 1 write after the erase is regarded as 1 rewrite. The retaining years are until next rewrite after the rewrite.
 2. When using flash memory programmer and Renesas Electronics self programming library.
 3. These are the characteristics of the flash memory and the results obtained from reliability testing by Renesas Electronics Corporation.
 4. This temperature is the average value at which data are retained.

30.9 Dedicated Flash Memory Programmer Communication (UART)

(T_A = -40 to +105°C, 2.4 V ≤ EV_{DD0} = EV_{DD1} ≤ V_{DD} ≤ 5.5 V, V_{SS} = EV_{SS0} = EV_{SS1} = 0 V)

Parameter	Symbol	Conditions	MIN.	TYP.	MAX.	Unit
Transfer rate		During serial programming	115,200		1,000,000	bps

30.10 Timing of Entry to Flash Memory Programming Modes

(T_A = -40 to +105°C, 2.4 V ≤ EV_{DD0} = EV_{DD1} ≤ V_{DD} ≤ 5.5 V, V_{SS} = EV_{SS0} = EV_{SS1} = 0 V)

Parameter	Symbol	Conditions	MIN.	TYP.	MAX.	Unit
Time to complete the communication for the initial setting after the external reset is released	t _{SUINIT}	POR and LVD reset must be released before the external reset is released.			100	ms
Time to release the external reset after the TOOL0 pin is set to the low level	t _{SU}	POR and LVD reset must be released before the external reset is released.	10			μs
Time to hold the TOOL0 pin at the low level after the external reset is released (excluding the processing time of the firmware to control the flash memory)	t _{HD}	POR and LVD reset must be released before the external reset is released.	1			ms

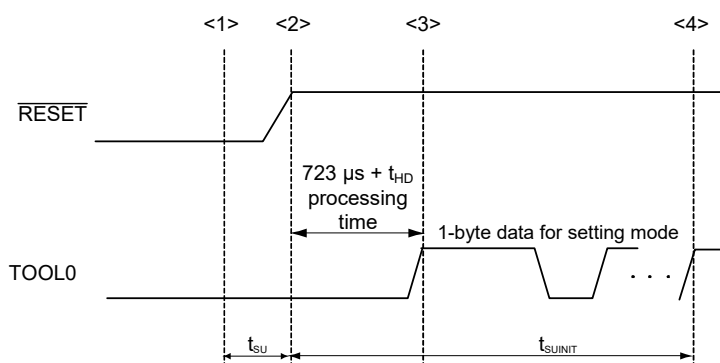

- <1> The low level is input to the TOOL0 pin.
- <2> The external reset is released (POR and LVD reset must be released before the external reset is released.).
- <3> The TOOL0 pin is set to the high level.
- <4> Setting of the flash memory programming mode by UART reception and complete the baud rate setting.

Remark t_{SUINIT}: Communication for the initial setting must be completed within 100 ms after the external reset is released during this period.

t_{SU}: Time to release the external reset after the TOOL0 pin is set to the low level

t_{HD}: Time to hold the TOOL0 pin at the low level after the external reset is released (excluding the processing time of the firmware to control the flash memory)

CHAPTER 31 PACKAGE DRAWINGS

31.1 20-pin Package

JEITA Package Code	RENESAS Code	Previous Code	MASS (TYP.) [g]
P-LSSOP20-0300-0.65	PLSP0020JC-A	S20MC-65-5A4-3	0.12

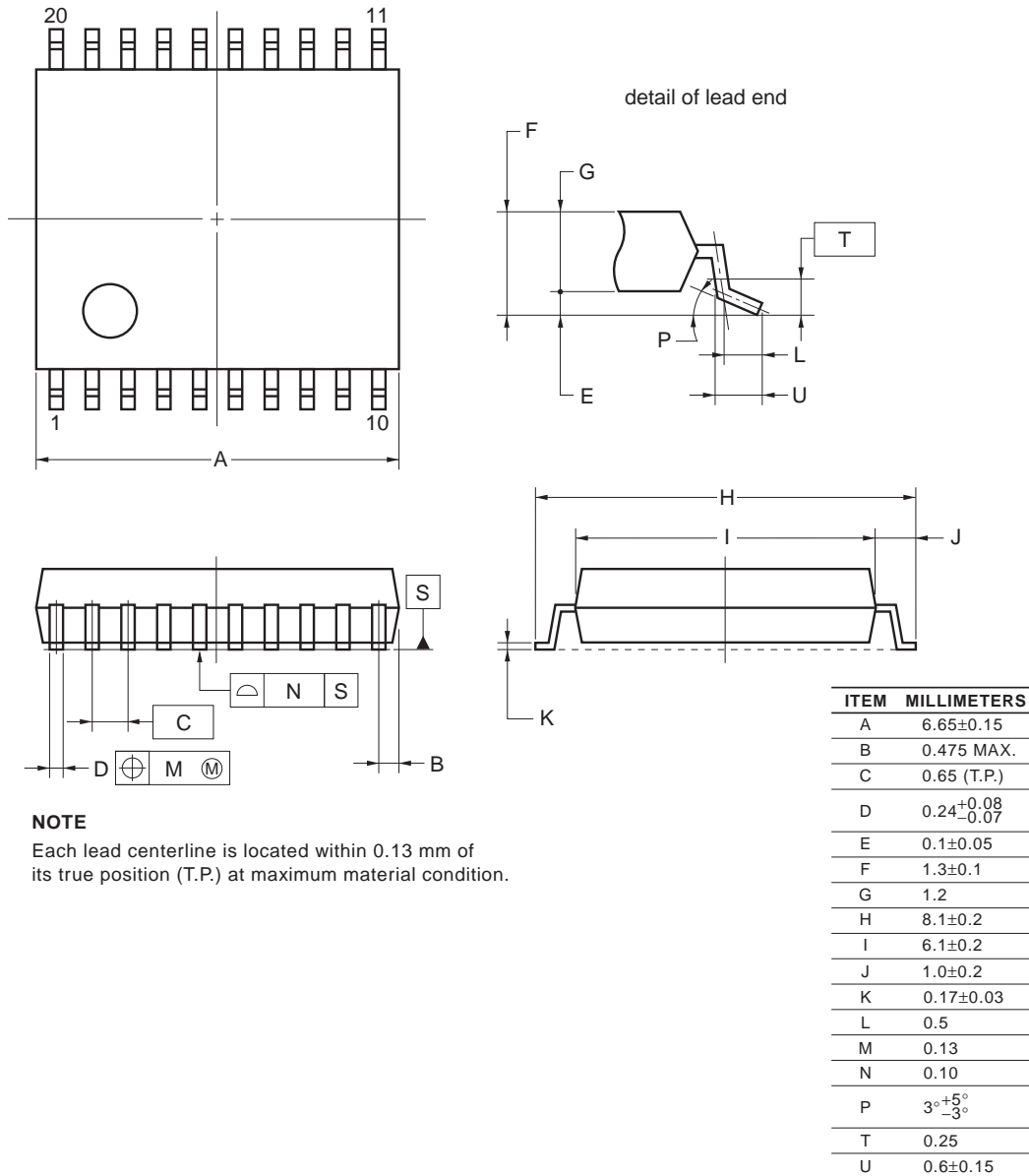

NOTE

Each lead centerline is located within 0.13 mm of its true position (T.P.) at maximum material condition.

©2012 Renesas Electronics Corporation. All rights reserved.

JEITA Package code	RENESAS code	MASS(TYP.)[g]
P-TSSOP20-4.40x6.50-0.65	PTSP0020JI-A	0.08

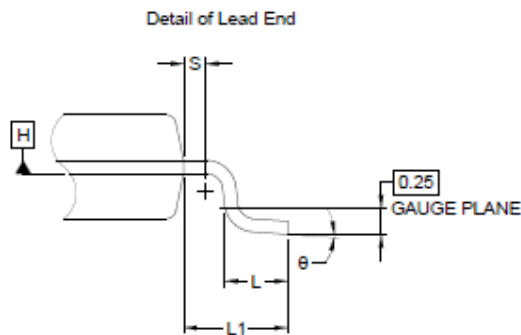
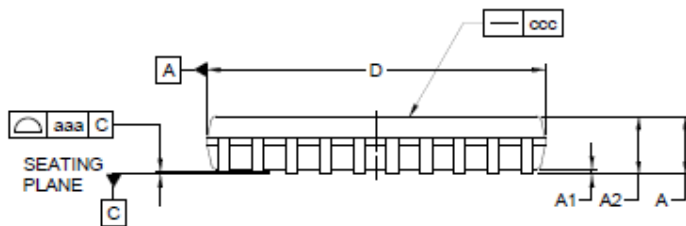
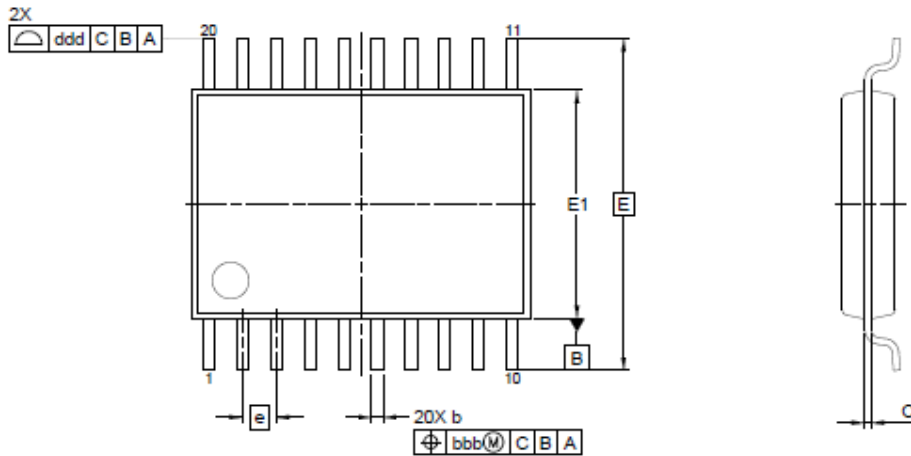

Reference Symbol	Dimension in Millimeters		
	Min.	Nom.	Max.
A	-	-	1.20
A1	0.05	-	0.15
A2	0.80	1.00	1.05
b	0.19	-	0.30
C	0.09	0.127	0.20
D	6.40	6.50	6.60
E1	4.30	4.40	4.50
E	6.40 BSC		
e	0.65 BSC		
L1	1.00 REF		
L	0.50	0.60	0.75
S	0.20	-	-
θ	0°	-	8°
aaa	0.10		
bbb	0.10		
ccc	0.05		
ddd	0.20		

NOTES:
 1. DIMENSION 'D' AND 'E1' DOES NOT INCLUDE MOLD FLASH.
 2. DIMENSION 'b' DOES NOT INCLUDE TRIM OFFSET.
 3. DIMENSION 'D' AND 'E1' TO BE DETERMINED AT DATUM PLANE [A].

31.2 24-pin Package

JEITA Package code	RENESAS code	Previous code	MASS(TYP.)[g]
P-HWQFN24-4x4-0.50	PWQN0024KE-A	P24K8-50-CAB-3	0.04

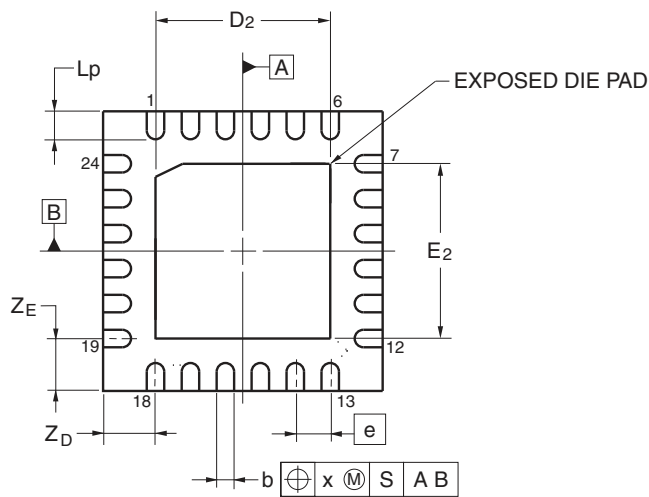
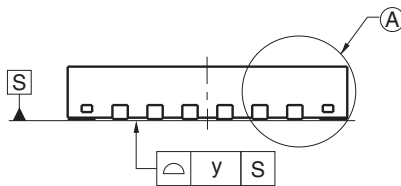
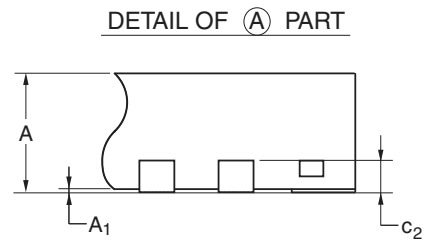
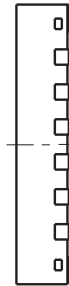
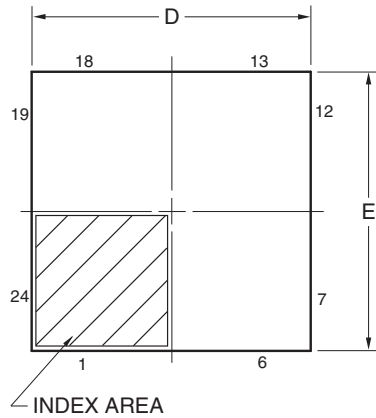

Reference Symbol	Dimension in Millimeters		
	Min	Nom	Max
D	3.95	4.00	4.05
E	3.95	4.00	4.05
A	—	—	0.80
A ₁	0.00	—	—
b	0.18	0.25	0.30
e	—	0.50	—
L _p	0.30	0.40	0.50
x	—	—	0.05
y	—	—	0.05
Z _D	—	0.75	—
Z _E	—	0.75	—
c ₂	0.15	0.20	0.25
D ₂	—	2.50	—
E ₂	—	2.50	—

JEITA Package code	RENESAS code	MASS(TYP.)[g]
P-HWQFN024-4x4-0.50	PWQN0024KF-A	0.04

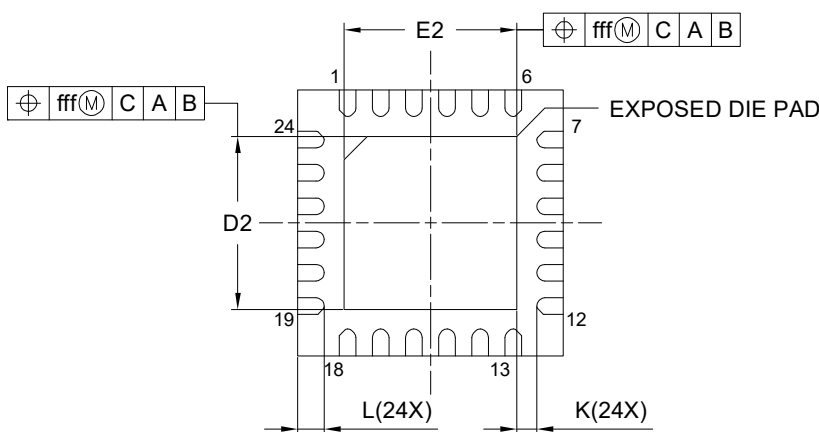
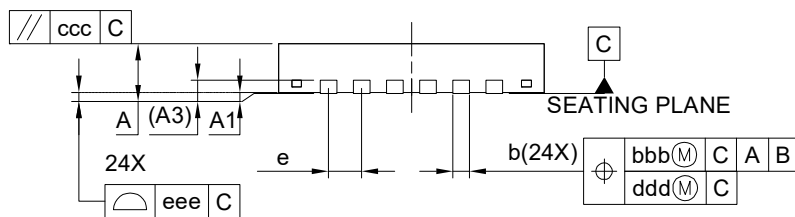
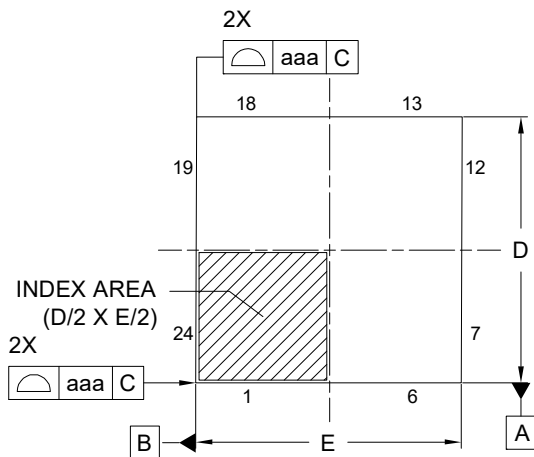

Reference Symbol	Dimension in Millimeters		
	Min.	Nom.	Max.
A	—	—	0.80
A1	0.00	0.02	0.05
A3	0.203 REF.		
b	0.18	0.25	0.30
D	4.00 BSC		
E	4.00 BSC		
e	0.50 BSC		
L	0.35	0.40	0.45
K	0.20	—	—
D2	2.55	2.60	2.65
E2	2.55	2.60	2.65
aaa	0.15		
bbb	0.10		
ccc	0.10		
ddd	0.05		
eee	0.08		
fff	0.10		

JEITA Package Code	RENESAS Code	MASS(Typ.)[g]
P-HWQFN24-4×4-0.50	PWQN0024KH-A	0.04

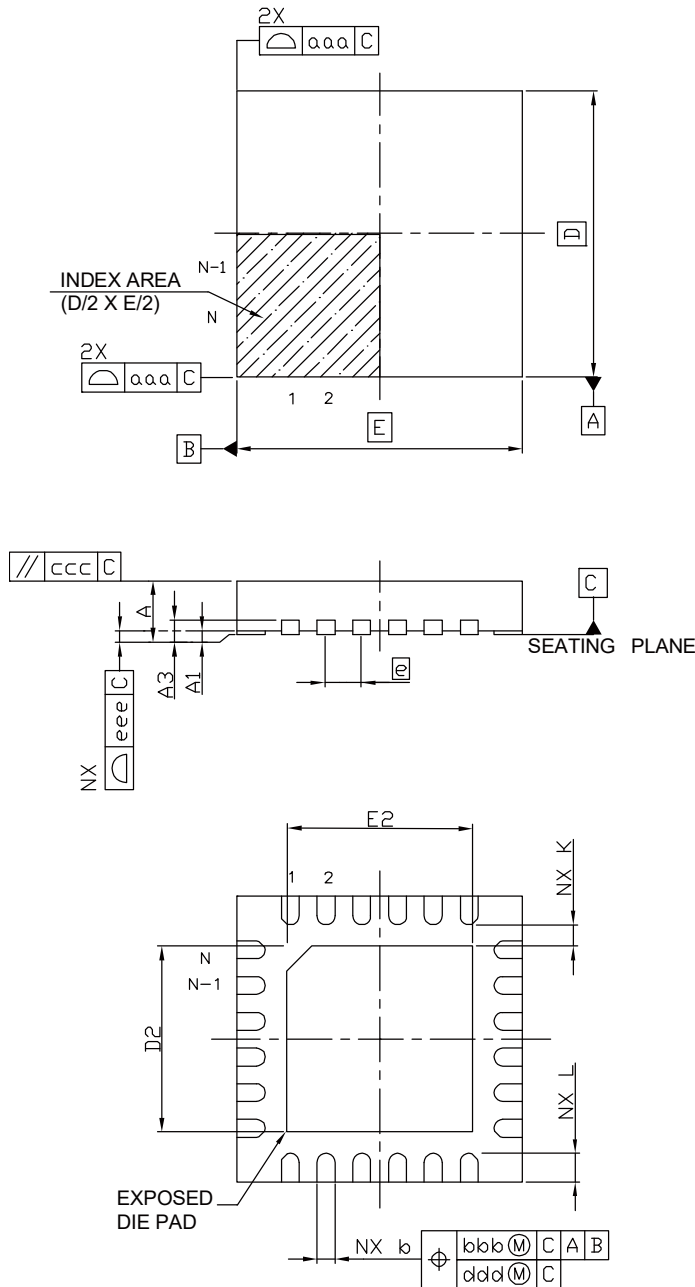

Referenc Symbol	Dimension in Millimeters		
	Min.	Nom.	Max.
A	—	—	0.80
A ₁	0.00	—	0.05
A ₃	0.20 REF.		
b	0.20	0.25	0.30
D	—	4.00	—
E	—	4.00	—
e	—	0.50	—
N	24		
L	0.30	0.40	0.50
K	0.20	—	—
D ₂	2.50	2.60	2.70
E ₂	2.50	2.60	2.70
aaa	—	—	0.15
bbb	—	—	0.10
ccc	—	—	0.10
ddd	—	—	0.05
eee	—	—	0.08

31.3 25-pin Package

JEITA Package Code	RENESAS Code	Previous Code	MASS (TYP.) [g]
P-WFLGA25-3x3-0.50	PWLG0025KA-A	P25FC-50-2N2-2	0.01

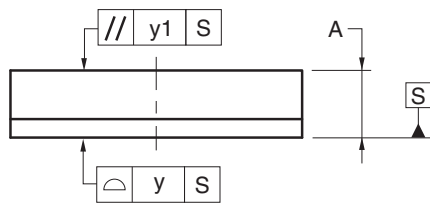
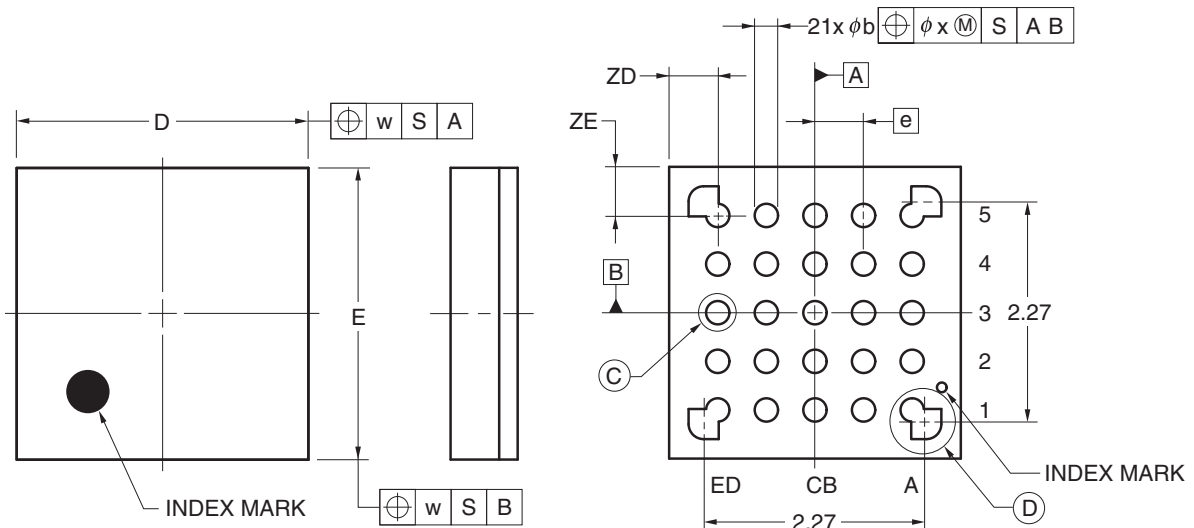

DETAIL OF ③ PART

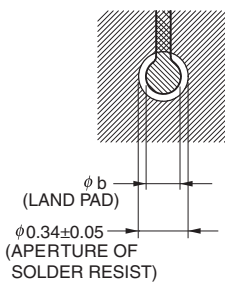

DETAIL OF ④ PART

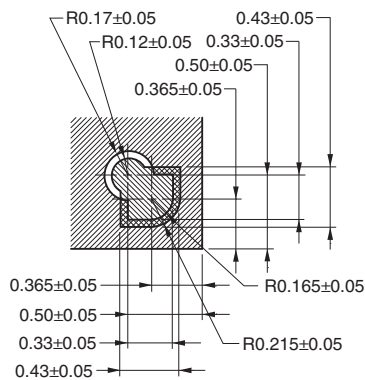

(UNIT:mm)

ITEM	DIMENSIONS
D	3.00±0.10
E	3.00±0.10
w	0.20
e	0.50
A	0.69±0.07
b	0.24±0.05
x	0.05
y	0.08
y1	0.20
ZD	0.50
ZE	0.50

©2012 Renesas Electronics Corporation. All rights reserved.

31.4 30-pin Package

JEITA Package Code	RENESAS Code	Previous Code	MASS (TYP.) [g]
P-LSSOP30-0300-0.65	PLSP0030JB-B	S30MC-65-5A4-3	0.18

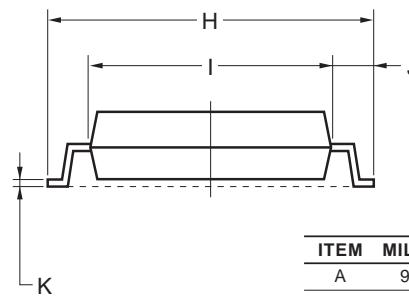
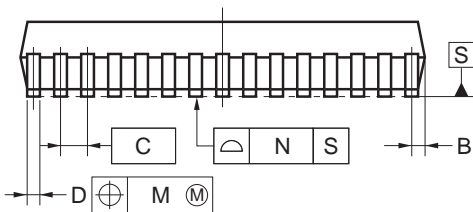
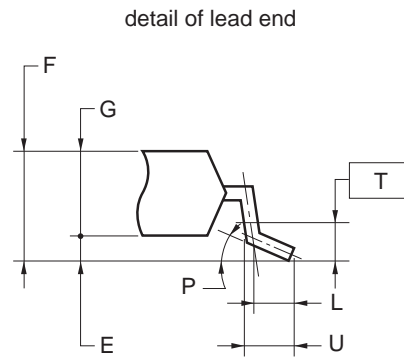
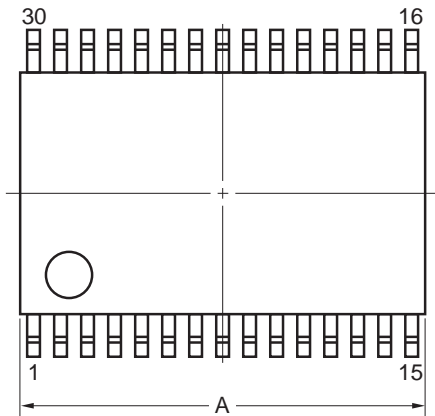

NOTE

Each lead centerline is located within 0.13 mm of its true position (T.P.) at maximum material condition.

ITEM	MILLIMETERS
A	9.85±0.15
B	0.45 MAX.
C	0.65 (T.P.)
D	0.24 ^{+0.08} _{-0.07}
E	0.1±0.05
F	1.3±0.1
G	1.2
H	8.1±0.2
I	6.1±0.2
J	1.0±0.2
K	0.17±0.03
L	0.5
M	0.13
N	0.10
P	3° ^{+5°} _{-3°}
T	0.25
U	0.6±0.15

©2012 Renesas Electronics Corporation. All rights reserved.

31.5 32-pin Package

JEITA Package code	RENESAS code	Previous code	MASS (TYP.)[g]
P-HWQFN32-5x5-0.50	PWQN0032KB-A	P32K8-50-3B4-5	0.06

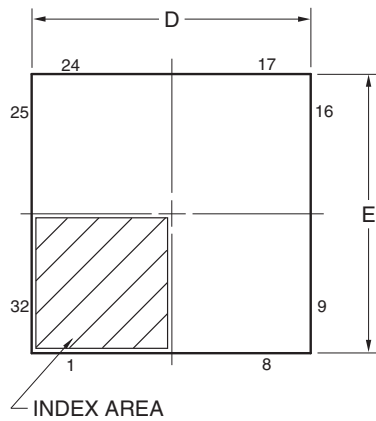

DETAIL OF (A) PART

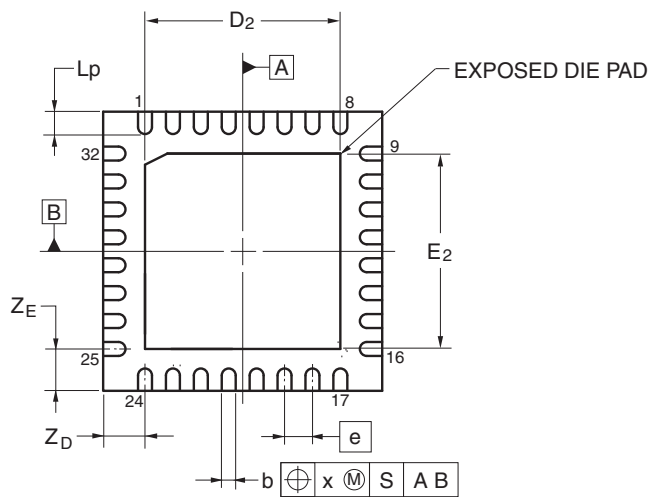
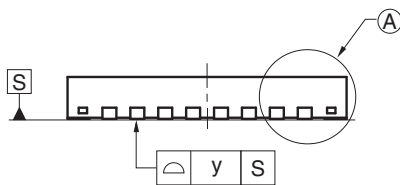
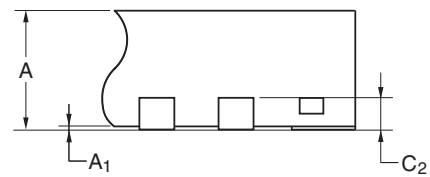

Reference Symbol	Dimension in Millimeters		
	Min	Nom	Max
D	4.95	5.00	5.05
E	4.95	5.00	5.05
A	—	—	0.80
A ₁	0.00	—	—
b	0.18	0.25	0.30
e	—	0.50	—
L _p	0.30	0.40	0.50
x	—	—	0.05
y	—	—	0.05
Z _D	—	0.75	—
Z _E	—	0.75	—
c ₂	0.15	0.20	0.25
D ₂	—	3.50	—
E ₂	—	3.50	—

©2013 Renesas Electronics Corporation. All rights reserved.

JEITA Package code	RENESAS code	MASS(TYP.)[g]
P-HWQFN032-5x5-0.50	PWQN0032KE-A	0.06

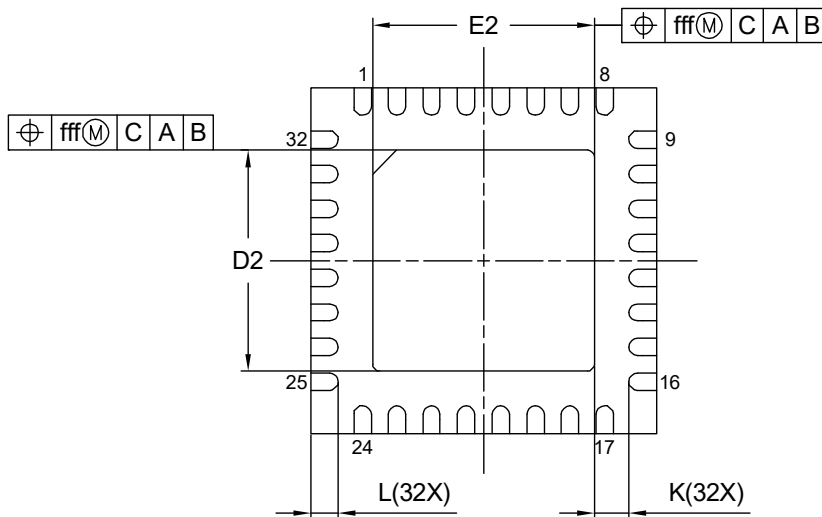
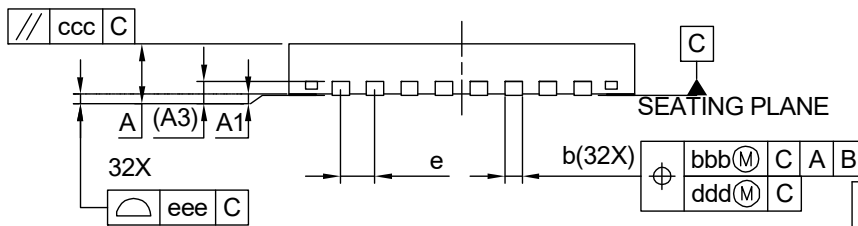
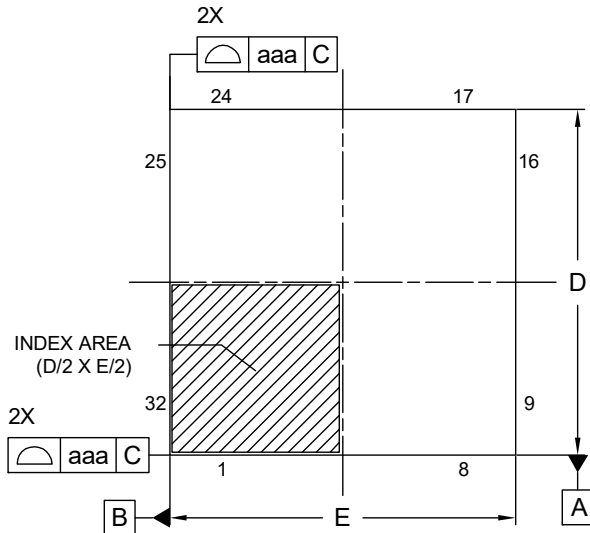

Reference Symbol	Dimension in Millimeters		
	Min.	Nom.	Max.
A	—	—	0.80
A ₁	0.00	0.02	0.05
A ₃	0.203 REF.		
b	0.18	0.25	0.30
D	5.00 BSC		
E	5.00 BSC		
e	0.50 BSC		
L	0.35	0.40	0.45
K	0.20	—	—
D ₂	3.15	3.20	3.25
E ₂	3.15	3.20	3.25
aaa	0.15		
bbb	0.10		
ccc	0.10		
ddd	0.05		
eee	0.08		
fff	0.10		

JEITA Package Code	RENESAS Code	MASS(Typ.)[g]
P-HWQFN32-5×5-0.50	PWQN0032KG-A	0.06

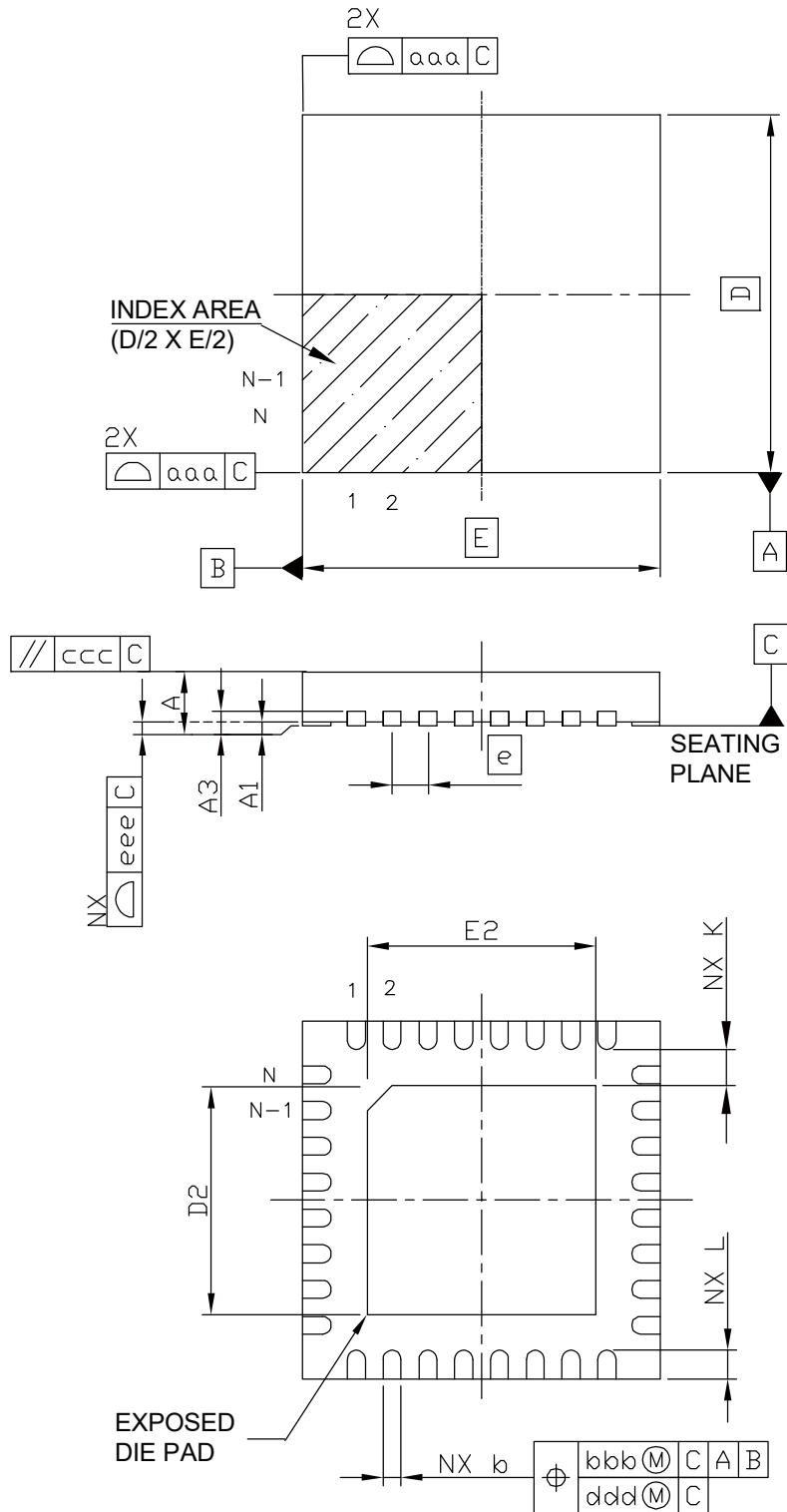

Reference Symbol	Dimension in Millimeters		
	Min.	Nom.	Max.
A	—	—	0.80
A ₁	0.00	—	0.05
A ₃	0.20 REF.		
b	0.20	0.25	0.30
D	—	5.00	—
E	—	5.00	—
e	—	0.50	—
N	32		
L	0.30	0.40	0.50
K	0.20	—	—
D ₂	3.10	3.20	3.30
E ₂	3.10	3.20	3.30
aaa	—	—	0.15
bbb	—	—	0.10
ccc	—	—	0.10
ddd	—	—	0.05
eee	—	—	0.08

31.6 36-pin Package

JEITA Package Code	RENESAS Code	Previous Code	MASS (TYP.) [g]
P-WFLGA36-4x4-0.50	PWLG0036KA-A	P36FC-50-AA4-2	0.023

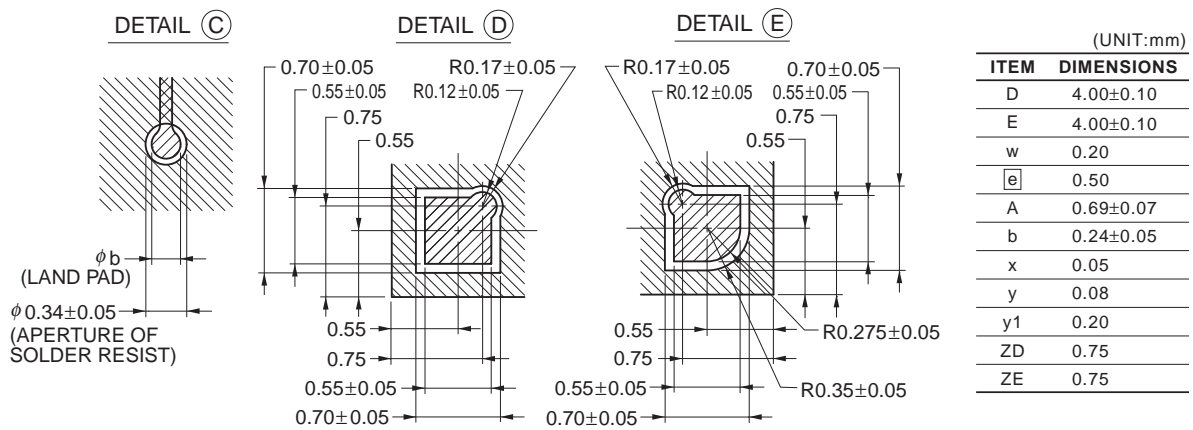
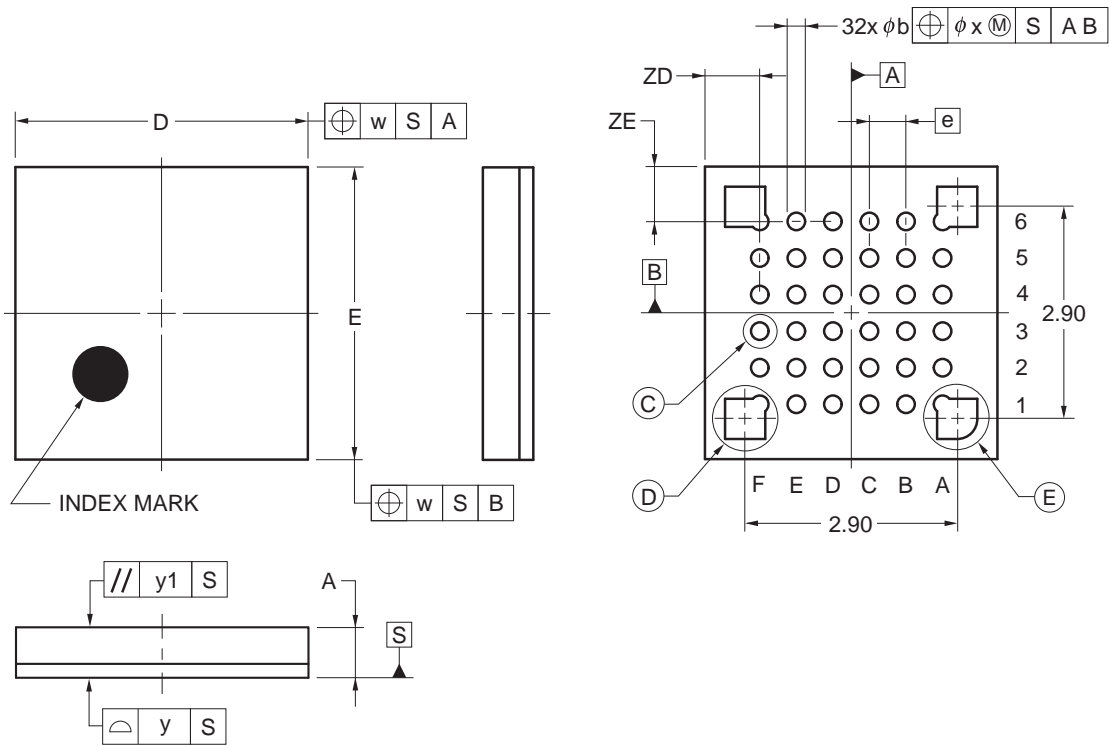

©2012 Renesas Electronics Corporation. All rights reserved.

31.7 40-pin Package

JEITA Package code	RENESAS code	Previous code	MASS (TYP) [g]
P-HWQFN40-6x6-0.50	PWQN0040KC-A	P40K8-50-4B4-5	0.09

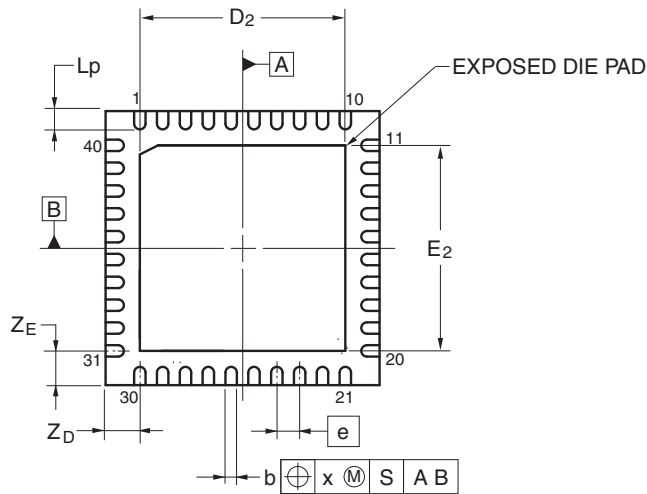
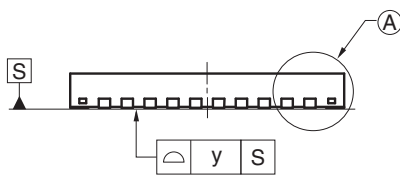
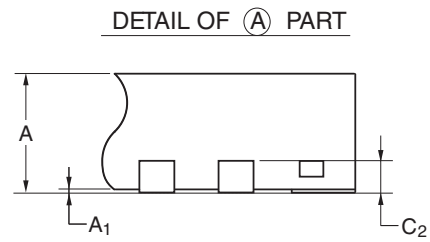
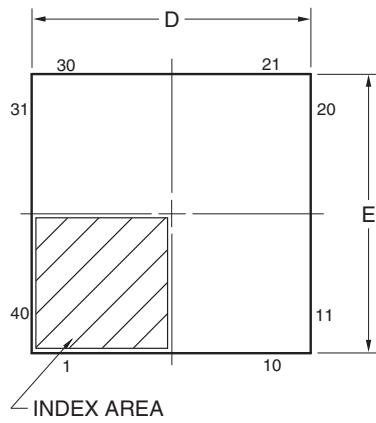

Reference Symbol	Dimension in Millimeters		
	Min	Nom	Max
D	5.95	6.00	6.05
E	5.95	6.00	6.05
A	—	—	0.80
A ₁	0.00	—	—
b	0.18	0.25	0.30
e	—	0.50	—
L _p	0.30	0.40	0.50
x	—	—	0.05
y	—	—	0.05
Z _D	—	0.75	—
Z _E	—	0.75	—
c ₂	0.15	0.20	0.25
D ₂	—	4.50	—
E ₂	—	4.50	—

©2013 Renesas Electronics Corporation. All rights reserved.

JEITA Package code	RENESAS code	MASS(TYP.)[g]
P-HWQFN040-6x6-0.50	PWQN0040KD-A	0.08

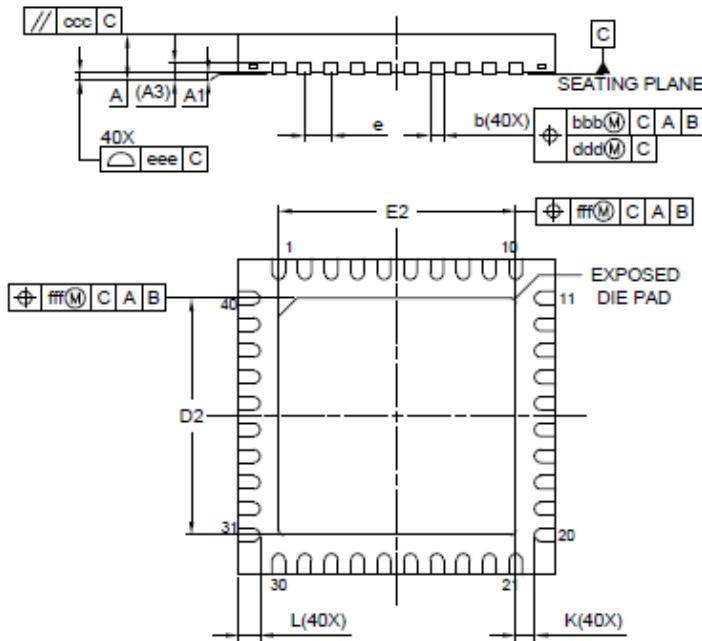
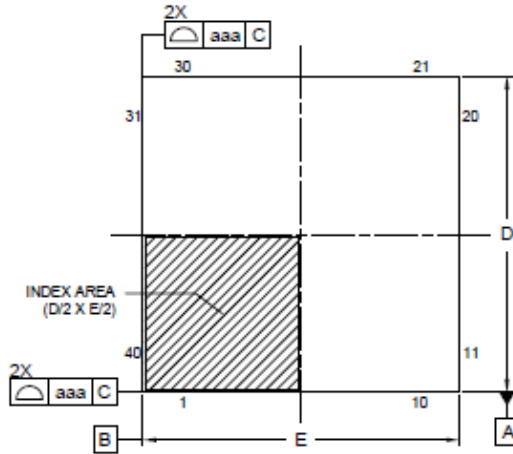

Reference Symbol	Dimension in Millimeters		
	Min.	Nom.	Max.
A	—	—	0.80
A ₁	0.00	0.02	0.05
A ₂	0.203 REF.		
b	0.18	0.25	0.30
D	6.00 BSC		
E	6.00 BSC		
e	0.50 BSC		
L	0.30	0.40	0.50
K	0.20	—	—
D ₂	4.45	4.50	4.55
E ₂	4.45	4.50	4.55
aaa	0.15		
bbb	0.10		
ccc	0.10		
ddd	0.05		
eee	0.08		
fff	0.10		

JEITA Package Code	RENESAS Code	MASS(Typ.)[g]
P-HWQFN40-6×6-0.50	PWQN0040KE-A	0.09

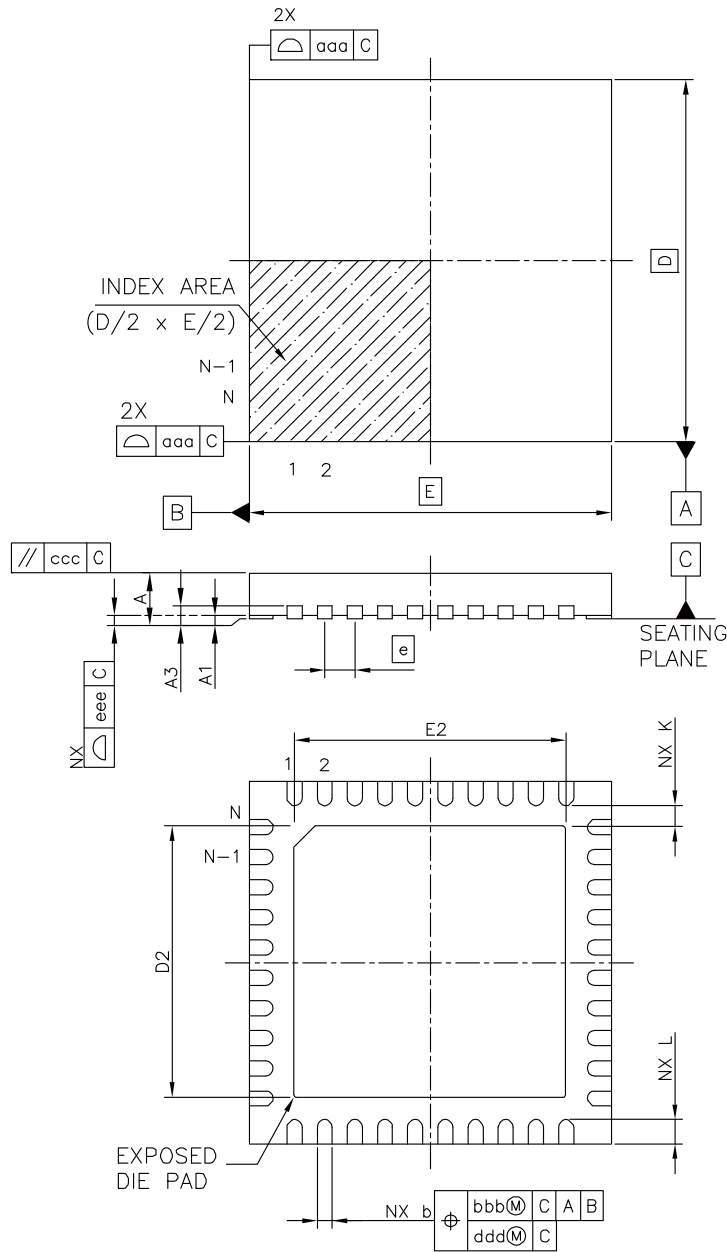

Reference Symbol	Dimension in Millimeters		
	Min.	Nom.	Max.
A	—	—	0.80
A ₁	0.00	—	0.05
A ₃	0.20 REF.		
b	0.20	0.25	0.30
D	—	6.00	—
E	—	6.00	—
e	—	0.50	—
N	40		
L	0.30	0.40	0.50
K	0.20	—	—
D ₂	4.40	4.50	4.60
E ₂	4.40	4.50	4.60
aaa	—	—	0.15
bbb	—	—	0.10
ccc	—	—	0.10
ddd	—	—	0.05
eee	—	—	0.08

31.8 44-pin Package

JEITA Package Code	RENESAS Code	Previous Code	MASS (TYP.) [g]
P-LQFP44-10x10-0.80	PLQP0044GC-A	P44GB-80-UES-2	0.36

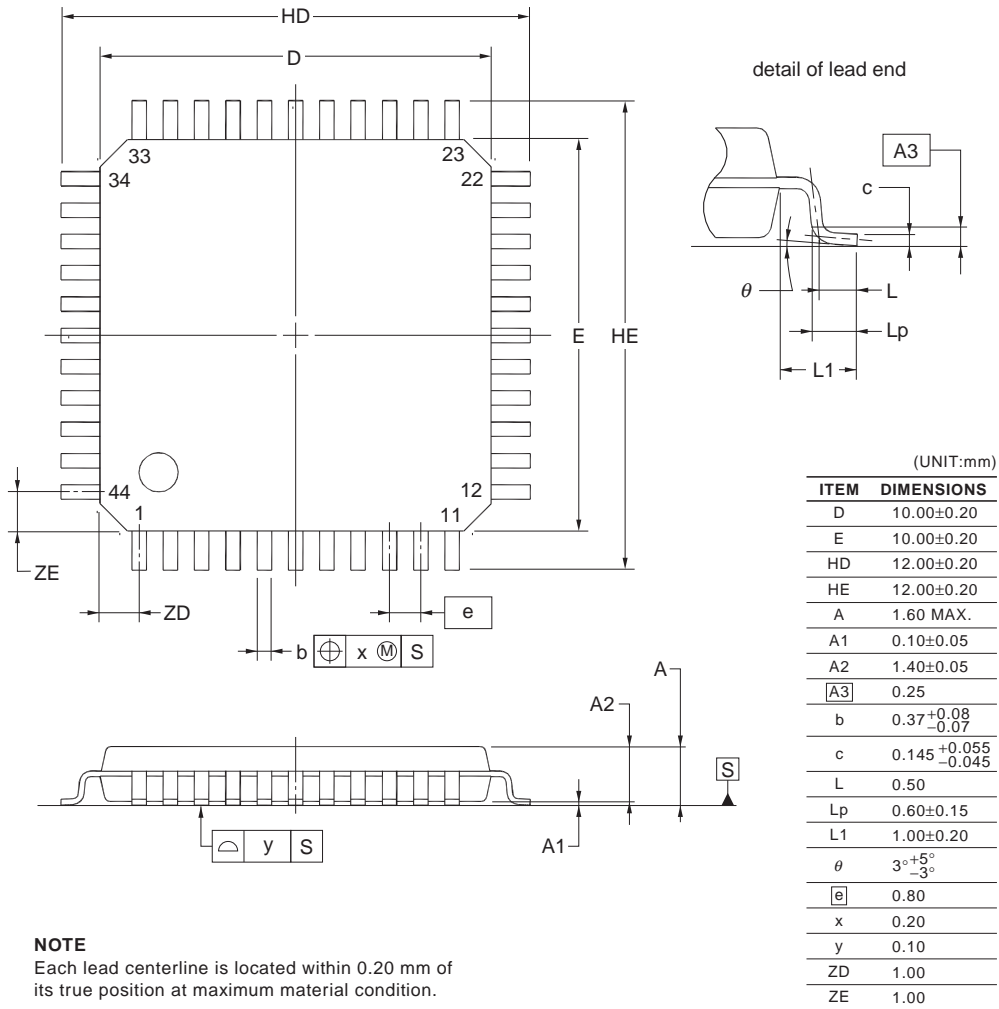

©2012 Renesas Electronics Corporation. All rights reserved.

JEITA Package Code	RENESAS Code	Previous Code	MASS[Typ.]
P-LQFP44-10x10-0.80	PLQP0044GC-D	—	0.36g

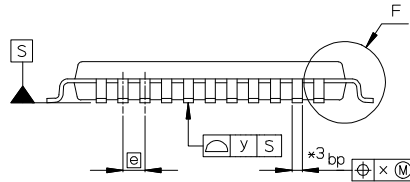
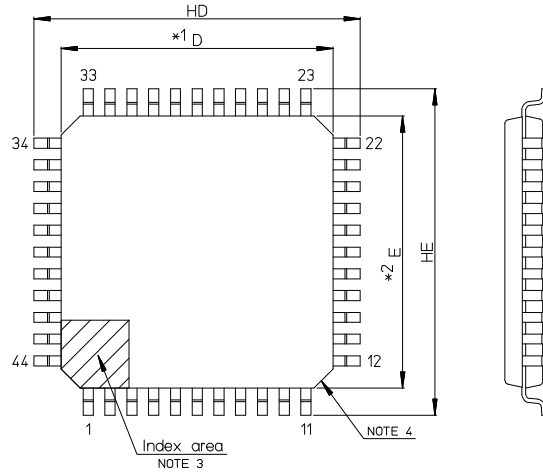

- NOTE)
1. DIMENSIONS *1* AND *2* DO NOT INCLUDE MOLD FLASH.
 2. DIMENSION *3* DOES NOT INCLUDE TRIM OFFSET.
 3. PIN 1 VISUAL INDEX FEATURE MAY VARY, BUT MUST BE LOCATED WITHIN THE HATCHED AREA.
 4. CHAMFERS AT CORNERS ARE OPTIONAL; SIZE MAY VARY.

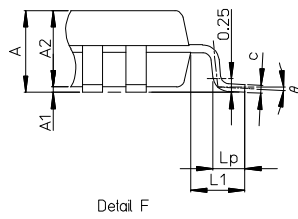

Reference Symbol	Dimension in Millimeters		
	Min	Nom	Max
D	9.8	10.0	10.2
E	9.8	10.0	10.2
A2	—	1.4	—
HD	11.8	12.0	12.2
HE	11.8	12.0	12.2
A	—	—	1.6
A1	0.05	—	0.15
bp	0.22	0.37	0.45
c	0.09	—	0.20
θ	0°	3.5°	8°
e	—	0.80	—
x	—	—	0.20
y	—	—	0.10
Lp	0.45	0.6	0.75
L1	—	1.0	—

JEITA Package code	RENESAS code	MASS(TYP.)[g]
P-LQFP044-10x10-0.80	PLQP0044GE-A	0.34

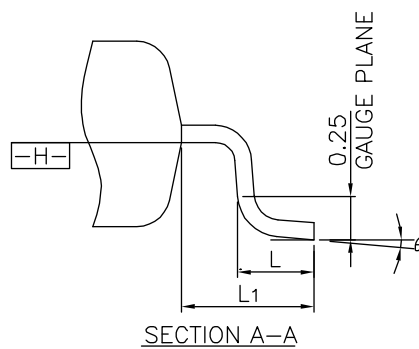
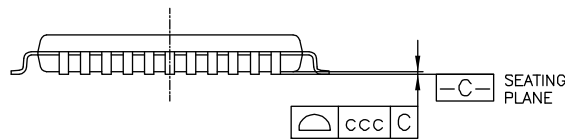
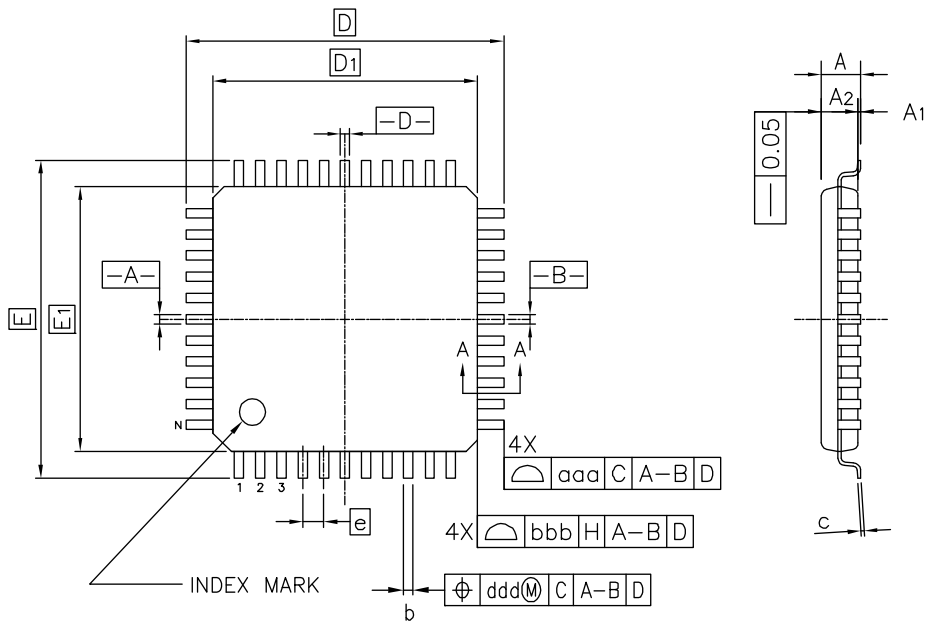

Reference Symbol	Dimension in Millimeters		
	Min.	Nom.	Max.
A	-	-	1.60
A ₁	0.05	-	0.15
A ₂	1.35	1.40	1.45
D	-	12.00	-
D ₁	-	10.00	-
E	-	12.00	-
E ₁	-	10.00	-
N	-	44	-
e	-	0.80	-
b	0.30	0.37	0.45
c	0.09	-	0.20
θ	0°	3.5°	7°
L	0.45	0.60	0.75
L ₁	-	1.00	-
aaa	-	-	0.20
bbb	-	-	0.20
ccc	-	-	0.10
ddd	-	-	0.20

<R>

JEITA Package code	RENESAS code	MASS(TYP.)[g]
P-LQFP44-10x10-0.80	PLQP0044GF-A	0.3

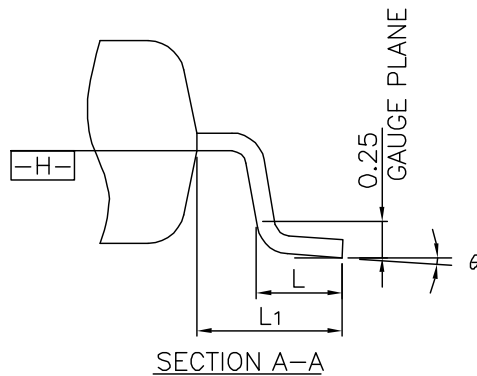
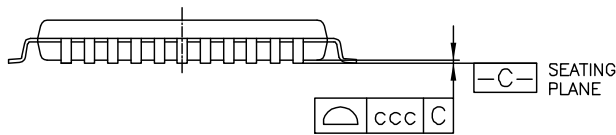
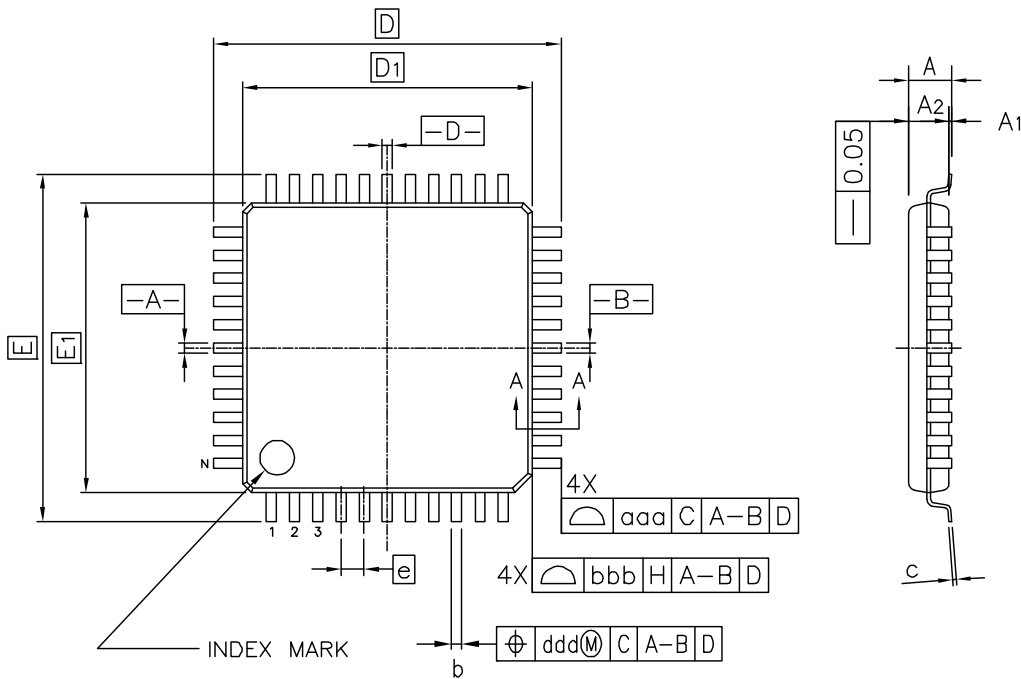

Reference Symbol	Dimension in Millimeters		
	Min.	Nom.	Max.
A	—	—	1.70
A ₁	0.05	—	0.15
A ₂	1.35	1.40	1.45
D	12.00 BSC.		
D ₁	10.00 BSC.		
E	12.00 BSC.		
E ₁	10.00 BSC.		
N	—	44	—
e	0.80 BSC.		
b	0.30	0.37	0.45
c	0.09	—	0.20
θ	0°	3.5°	8°
L	0.45	0.60	0.75
L ₁	1.00 REF.		
aaa	—	—	0.20
bbb	—	—	0.20
ccc	—	—	0.10
ddd	—	—	0.20

31.9 48-pin Package

JEITA Package Code	RENESAS Code	Previous Code	MASS (TYP.) [g]
P-LFQFP48-7x7-0.50	PLQP0048KF-A	P48GA-50-8EU-1	0.16

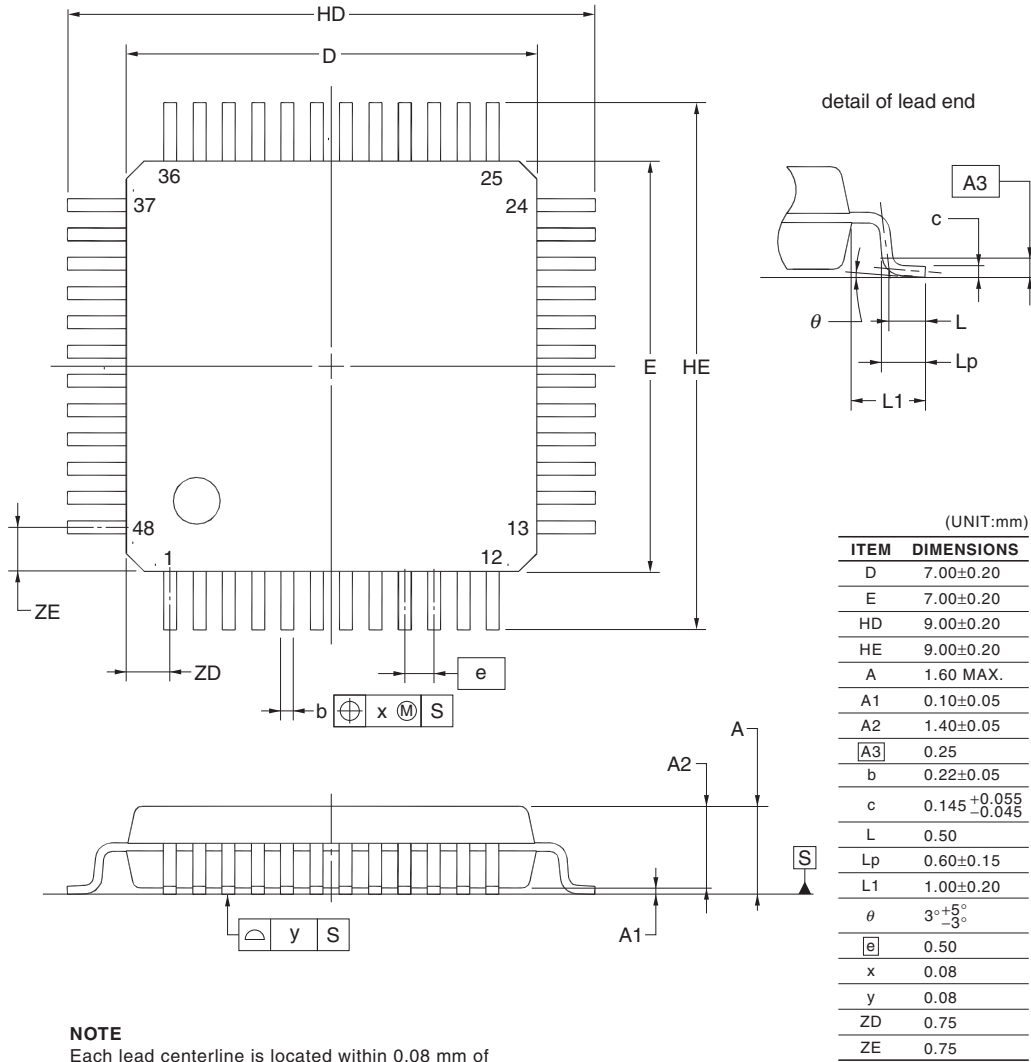

©2012 Renesas Electronics Corporation. All rights reserved.

JEITA Package Code	RENESAS Code	Previous Code	MASS (Typ) [g]
P-LFQFP48-7x7-0.50	PLQP0048KB-B	—	0.2

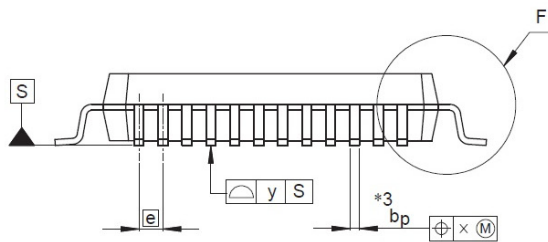
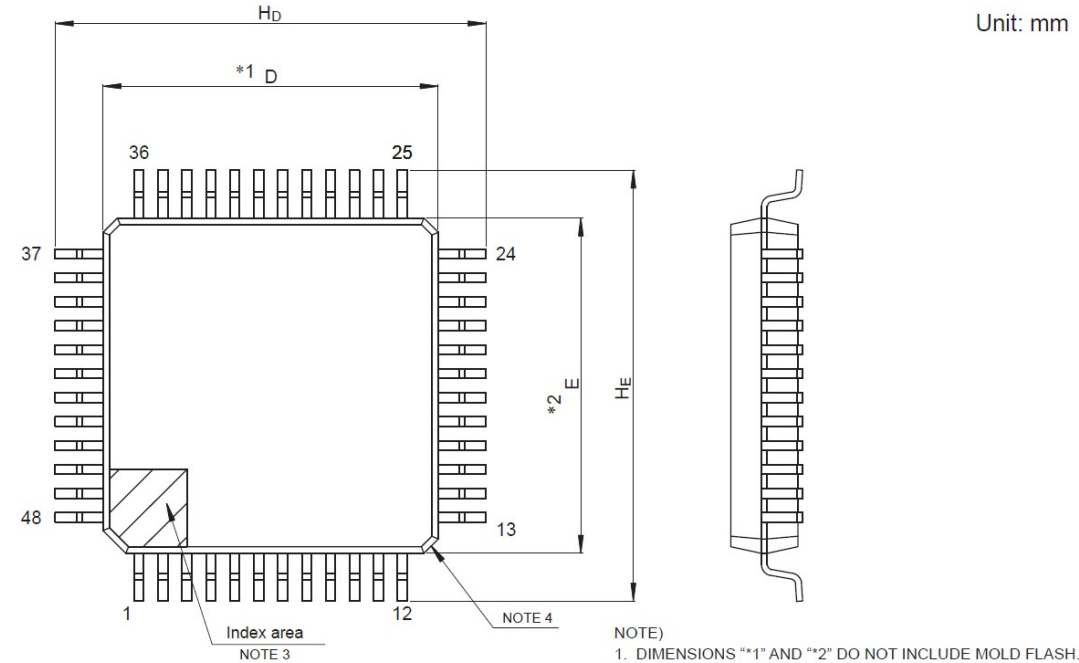

- NOTE)
1. DIMENSIONS **1* AND **2* DO NOT INCLUDE MOLD FLASH.
 2. DIMENSION **3* DOES NOT INCLUDE TRIM OFFSET.
 3. PIN 1 VISUAL INDEX FEATURE MAY VARY, BUT MUST BE LOCATED WITHIN THE HATCHED AREA.
 4. CHAMFERS AT CORNERS ARE OPTIONAL, SIZE MAY VARY.

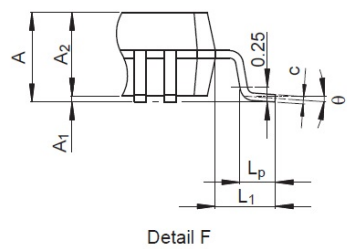

Reference Symbol	Dimensions in millimeters		
	Min	Nom	Max
D	6.9	7.0	7.1
E	6.9	7.0	7.1
A ₂	—	1.4	—
H _D	8.8	9.0	9.2
H _E	8.8	9.0	9.2
A	—	—	1.7
A ₁	0.05	—	0.15
b _p	0.17	0.20	0.27
c	0.09	—	0.20
θ	0°	3.5°	8°
e	—	0.5	—
x	—	—	0.08
y	—	—	0.08
L _p	0.45	0.6	0.75
L ₁	—	1.0	—

© 2015 Renesas Electronics Corporation. All rights reserved.

JEITA Package code	RENESAS code	MASS(TYP.)[g]
P-LFQFP48-7x7-0.50	PLQP0048KL-A	0.18

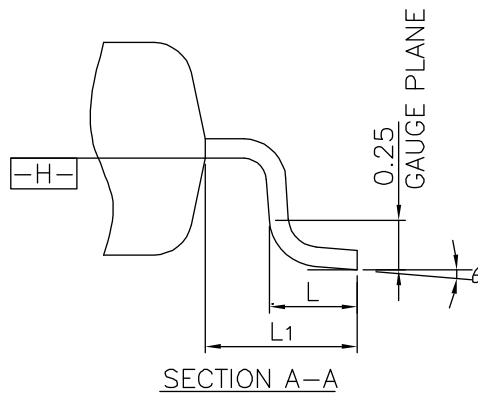
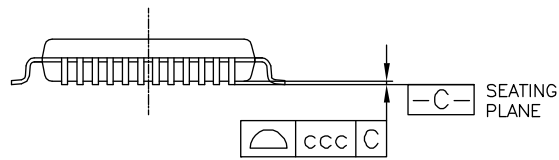
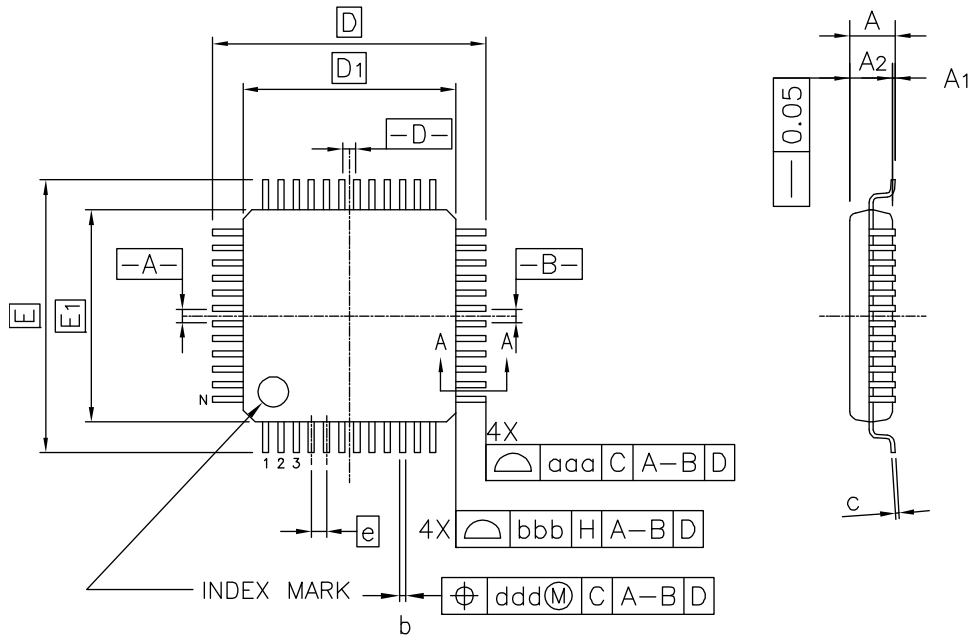

Reference Symbol	Dimension in Millimeters		
	Min.	Nom.	Max.
A	—	—	1.60
A ₁	0.05	—	0.15
A ₂	1.35	1.40	1.45
D	—	9.00	—
D ₁	—	7.00	—
E	—	9.00	—
E ₁	—	7.00	—
N	—	48	—
e	—	0.50	—
b	0.17	0.22	0.27
c	0.09	—	0.20
θ	0°	3.5°	7°
L	0.45	0.60	0.75
L ₁	—	1.00	—
aaa	—	—	0.20
bbb	—	—	0.20
ccc	—	—	0.08
ddd	—	—	0.08

JEITA Package code	RENESAS code	Previous code	MASS(TYP.)[g]
P-HWQFN48-7x7-0.50	PWQN0048KB-A	48PJN-A P48K8-50-5B4-6	0.13

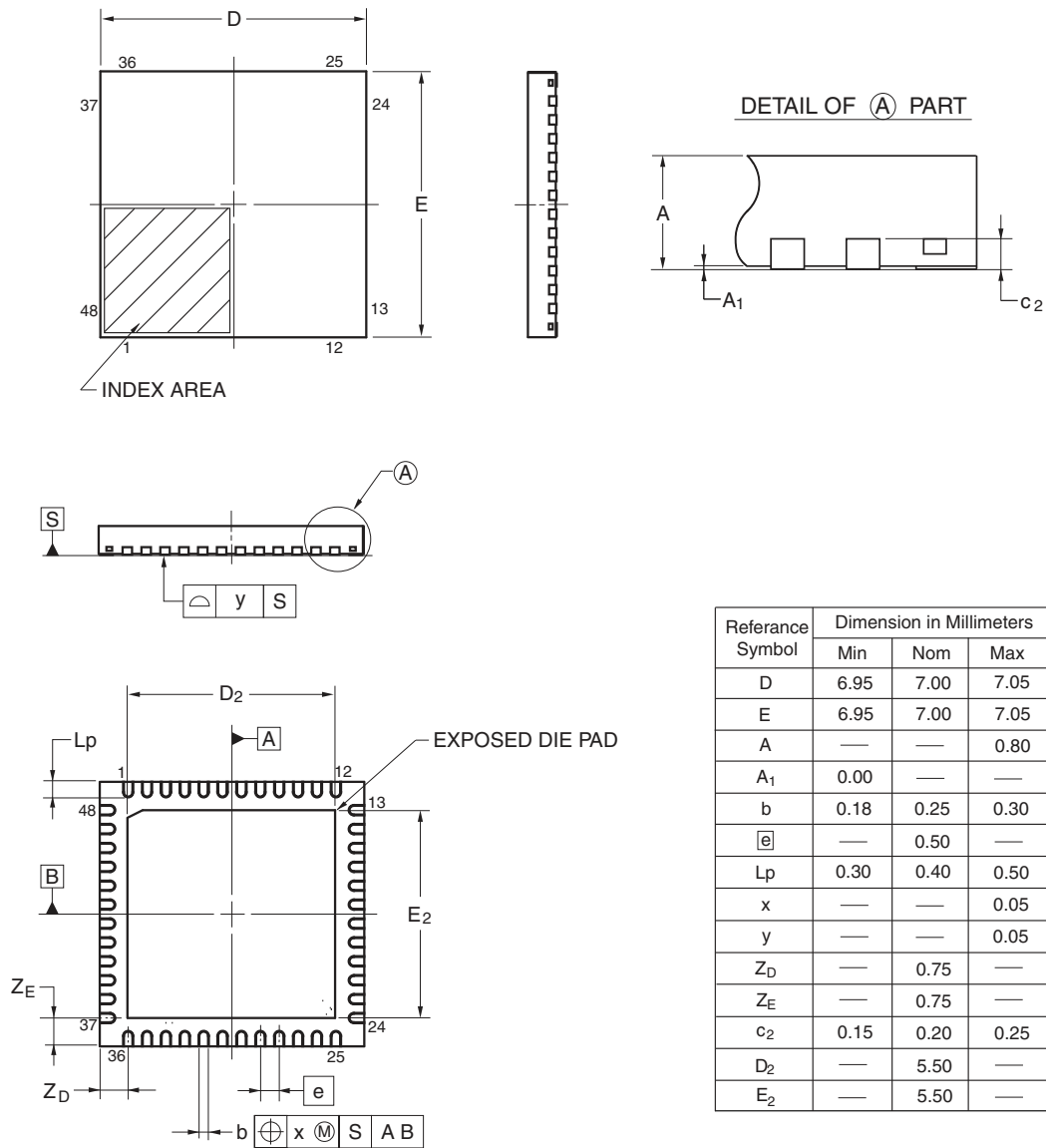

Reference Symbol	Dimension in Millimeters		
	Min	Nom	Max
D	6.95	7.00	7.05
E	6.95	7.00	7.05
A	—	—	0.80
A_1	0.00	—	—
b	0.18	0.25	0.30
e	—	0.50	—
L_p	0.30	0.40	0.50
x	—	—	0.05
y	—	—	0.05
Z_D	—	0.75	—
Z_E	—	0.75	—
c_2	0.15	0.20	0.25
D_2	—	5.50	—
E_2	—	5.50	—

©2013 Renesas Electronics Corporation. All rights reserved.

JEITA Package code	RENESAS code	MASS(TYP.)[g]
P-HWQFN048-7x7-0.50	PWQN0048KE-A	0.13

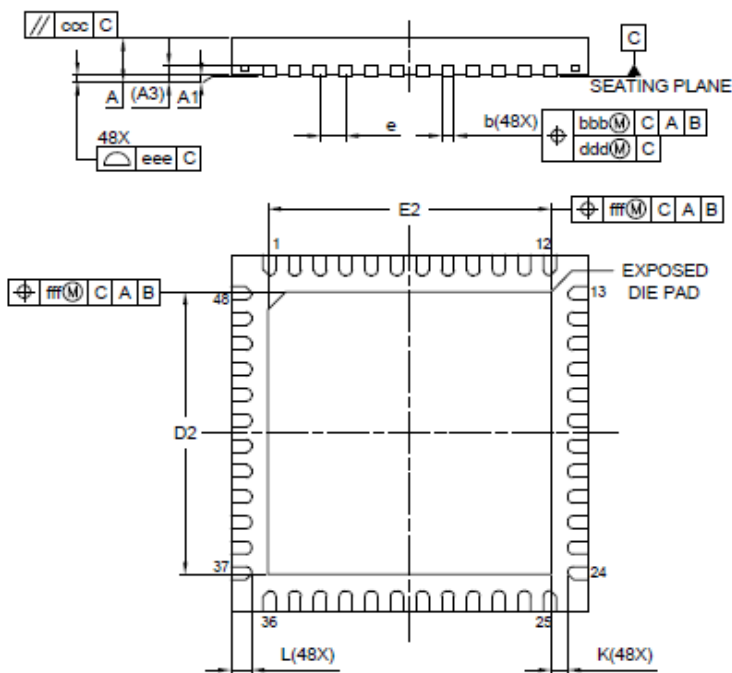
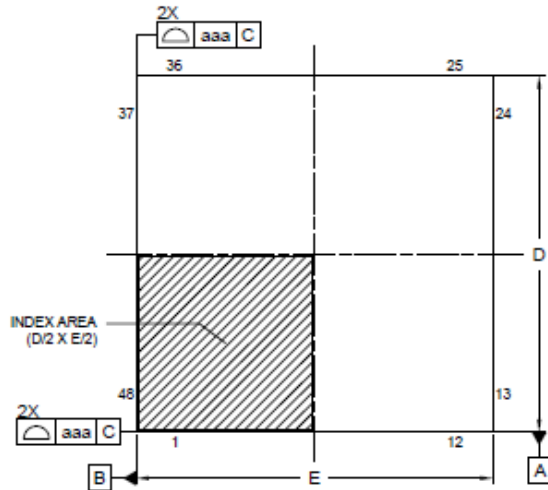

Reference Symbol	Dimension in Millimeters		
	Min.	Nom.	Max.
A	—	—	0.80
A ₁	0.00	0.02	0.05
A ₃	0.203 REF.		
b	0.20	0.25	0.30
D	7.00 BSC		
E	7.00 BSC		
e	0.50 BSC		
L	0.30	0.40	0.50
K	0.20	—	—
D ₂	5.50	5.55	5.60
E ₂	5.50	5.55	5.60
aaa	0.15		
bbb	0.10		
ccc	0.10		
ddd	0.05		
eee	0.08		
fff	0.10		

JEITA Package Code	RENESAS Code	MASS(Typ.)[g]
P-HWQFN48-7×7-0.50	PWQN0048KG-A	0.13

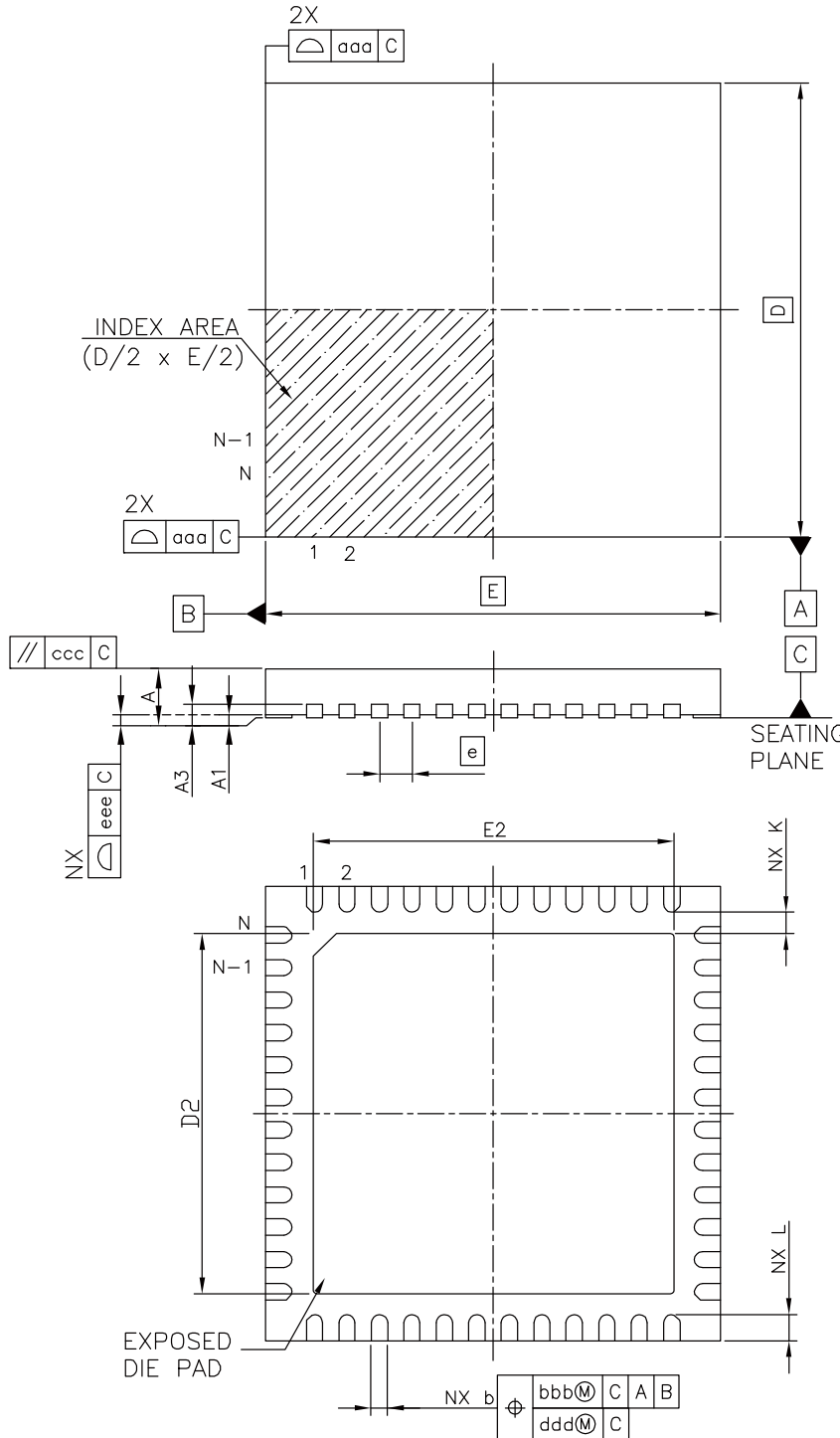

Reference Symbol	Dimension in Millimeters		
	Min.	Nom.	Max.
A	—	—	0.80
A ₁	0.00	—	0.05
A ₃	0.20 REF.		
b	0.20	0.25	0.30
D	—	7.00	—
E	—	7.00	—
e	—	0.50	—
N	48		
L	0.30	0.40	0.50
K	0.20	—	—
D ₂	5.50	5.55	5.60
E ₂	5.50	5.55	5.60
aaa	—	—	0.15
bbb	—	—	0.10
ccc	—	—	0.10
ddd	—	—	0.05
eee	—	—	0.08

31.10 52-pin Package

JEITA Package Code	RENESAS Code	Previous Code	MASS (TYP.) [g]
P-LQFP52-10x10-0.65	PLQP0052JA-A	P52GB-65-GBS-1	0.3

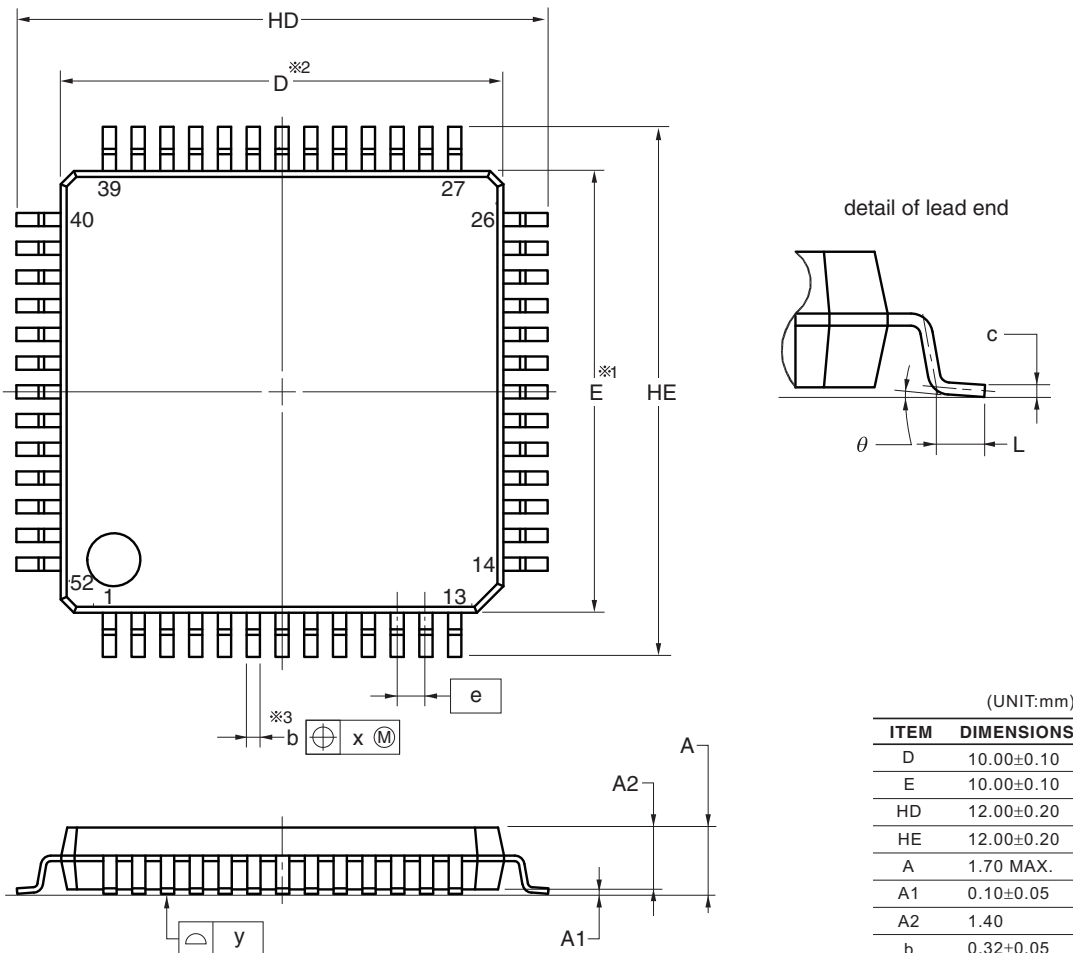

(UNIT:mm)

ITEM	DIMENSIONS
D	10.00±0.10
E	10.00±0.10
HD	12.00±0.20
HE	12.00±0.20
A	1.70 MAX.
A1	0.10±0.05
A2	1.40
b	0.32±0.05
c	0.145±0.055
L	0.50±0.15
θ	0° to 8°
e	0.65
x	0.13
y	0.10

NOTE

1. Dimensions “*1” and “*2” do not include mold flash.
2. Dimension “*3” does not include trim offset.

© 2012 Renesas Electronics Corporation. All rights reserved.

JEITA Package Code	RENESAS Code	Previous Code	MASS (TYP.) [g]
P-LQFP52-10x10-0.65	PLQP0052JD-B	P52GB-65-UET-2	0.36

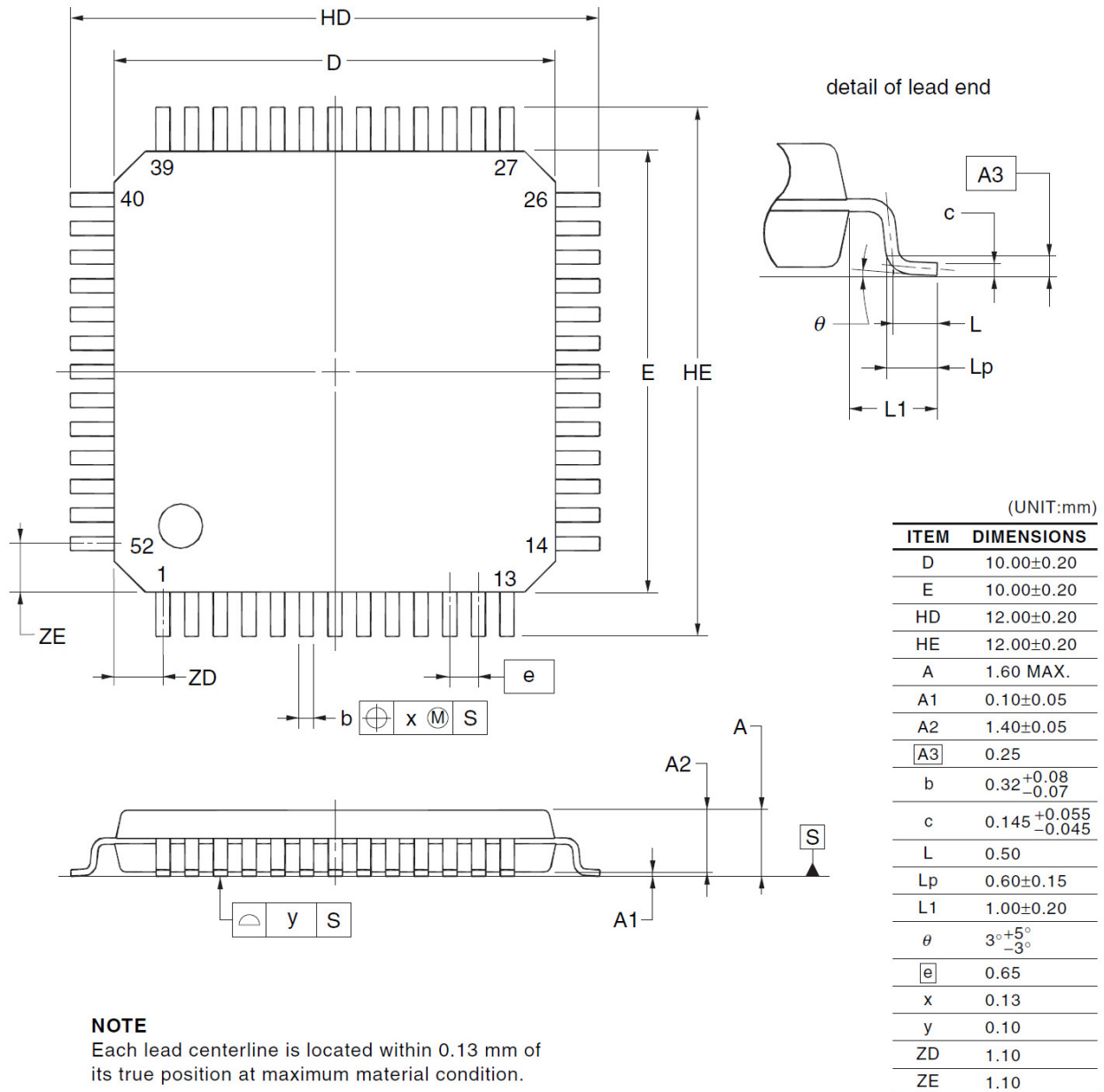

NOTE
Each lead centerline is located within 0.13 mm of its true position at maximum material condition.

31.11 64-pin Package

JEITA Package Code	RENESAS Code	Previous Code	MASS (TYP.) [g]
P-LQFP64-12x12-0.65	PLQP0064JA-A	P64GK-65-UET-2	0.51

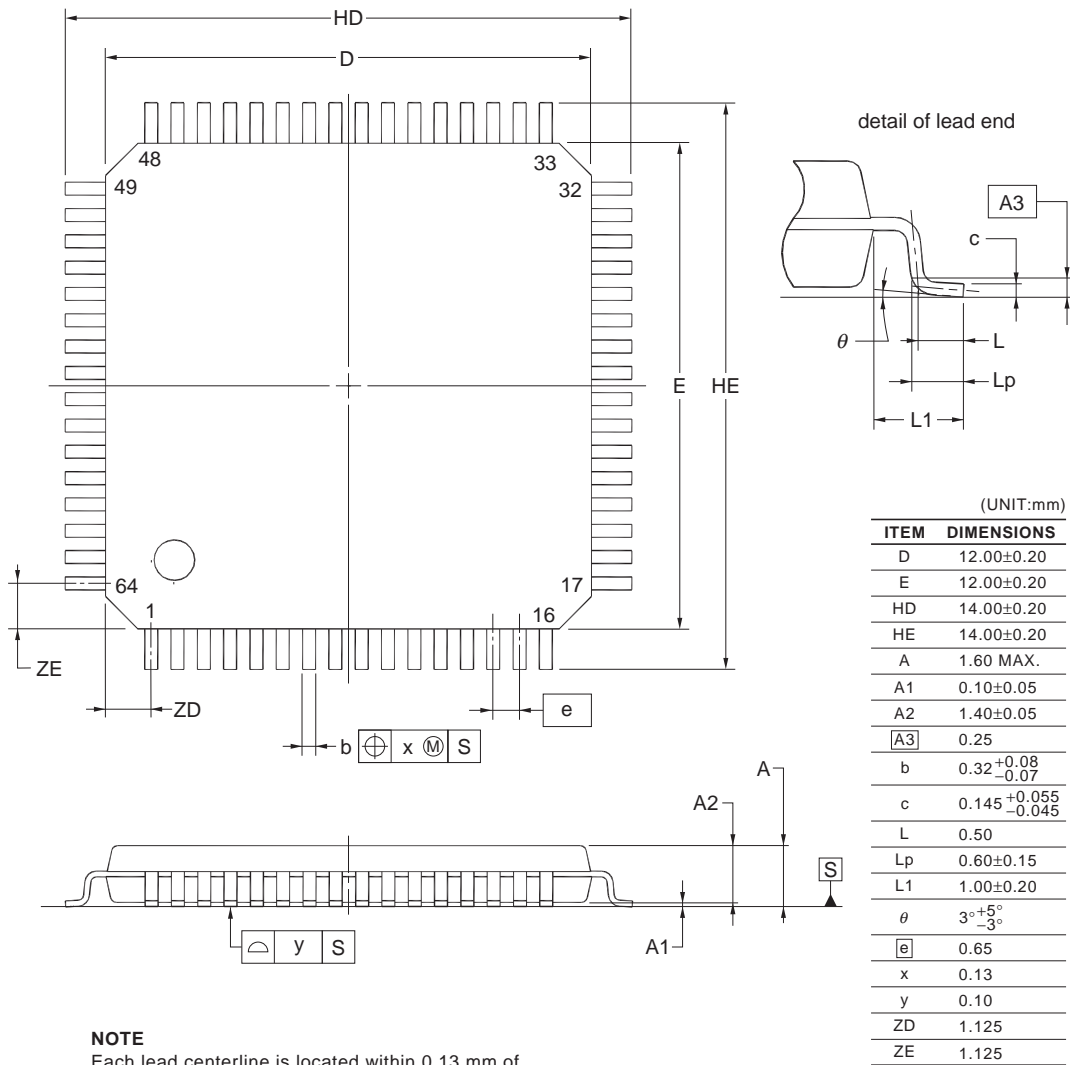

NOTE
Each lead centerline is located within 0.13 mm of its true position at maximum material condition.

©2012 Renesas Electronics Corporation. All rights reserved.

JEITA Package code	RENESAS code	MASS(TYP.)[g]
P-LQFP64-12x12-0.65	PLQP0064JB-A	0.50

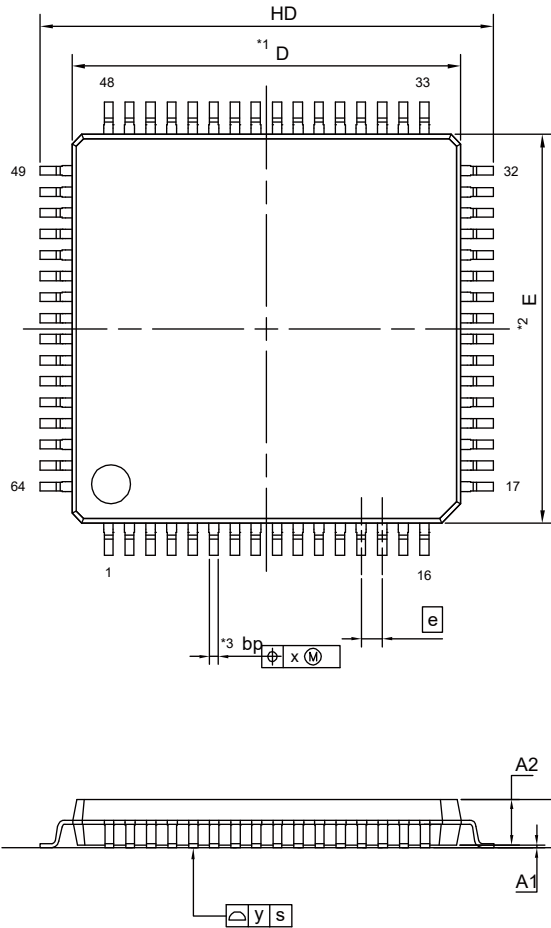

detail of lead end

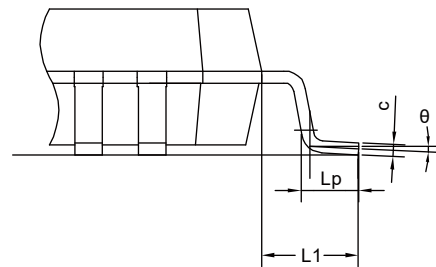

Reference Symbol	Dimension in Millimeters		
	Min.	Nom.	Max.
E	11.90	12.00	12.10
D	11.90	12.00	12.10
A ₂	—	1.40	—
H _D	13.80	14.00	14.20
H _E	13.80	14.00	14.20
A	—	—	1.70
A ₁	0.05	—	0.15
L _p	0.45	0.60	0.75
L ₁	—	1.00	—
b _p	0.27	0.32	0.37
c	0.09	—	0.20
e	—	0.65	—
θ	0.00	3.50	8.00
x	—	—	0.08
y	—	—	0.08

NOTE
 1.DIMENSIONS "*1" AND "*2" DO NOT INCLUDE MOLD FLASH.
 2.DIMENSION "*3" DOES NOT INCLUDE TRIM OFFSET.

JEITA Package Code	RENESAS Code	Previous Code	MASS (TYP.) [g]
P-LFQFP64-10x10-0.50	PLQP0064KF-A	P64GB-50-UEU-2	0.35

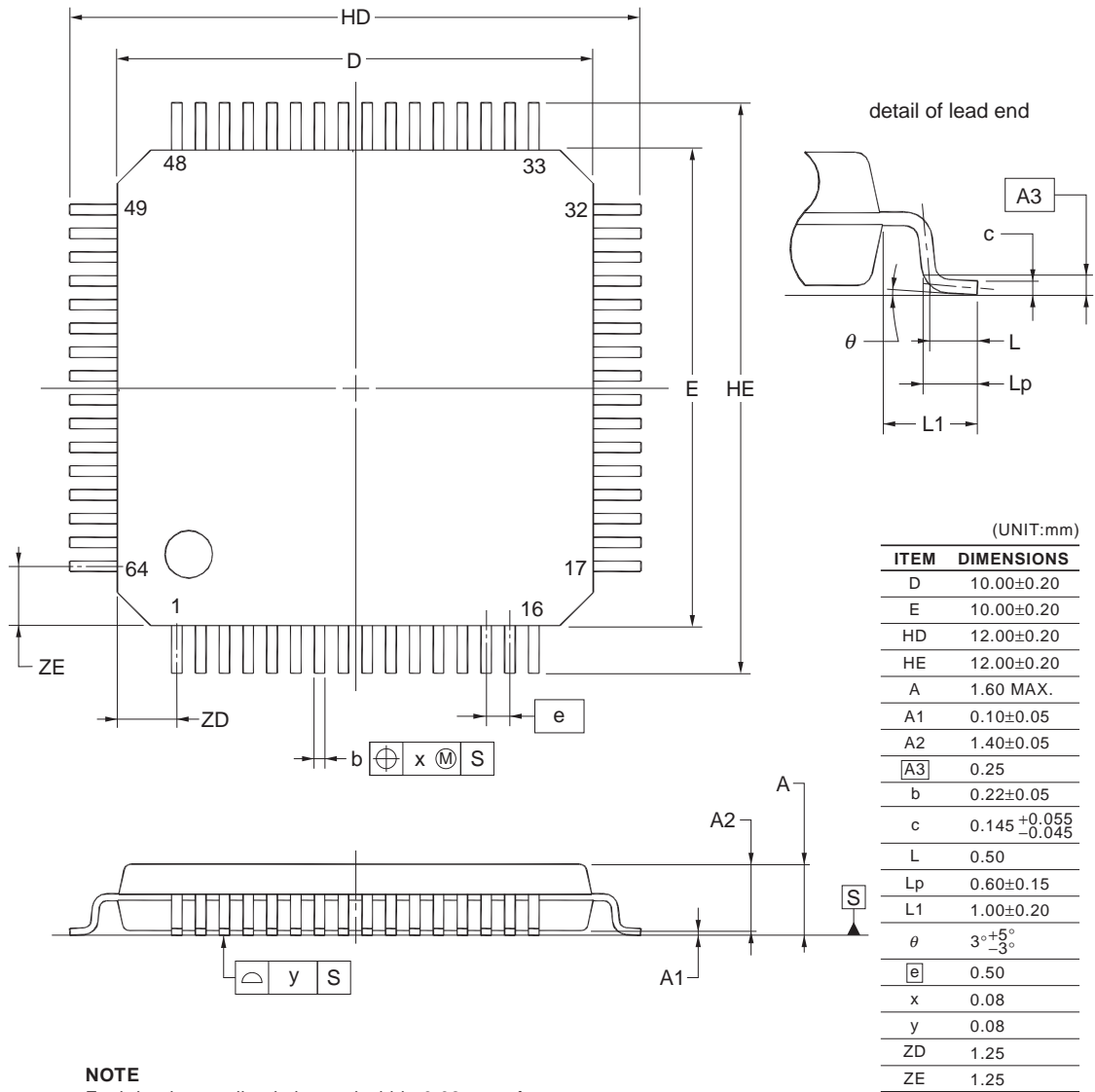

NOTE
 Each lead centerline is located within 0.08 mm of its true position at maximum material condition.

©2012 Renesas Electronics Corporation. All rights reserved.

JEITA Package Code	RENESAS Code	Previous Code	MASS (Typ) [g]
P-LFQFP64-10x10-0.50	PLQP0064KB-C	—	0.3

Unit: mm

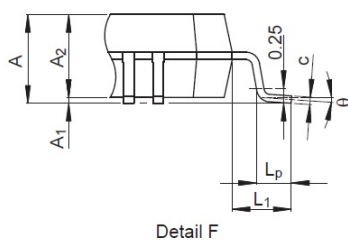
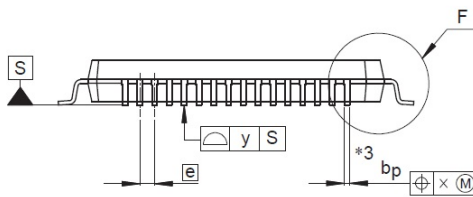
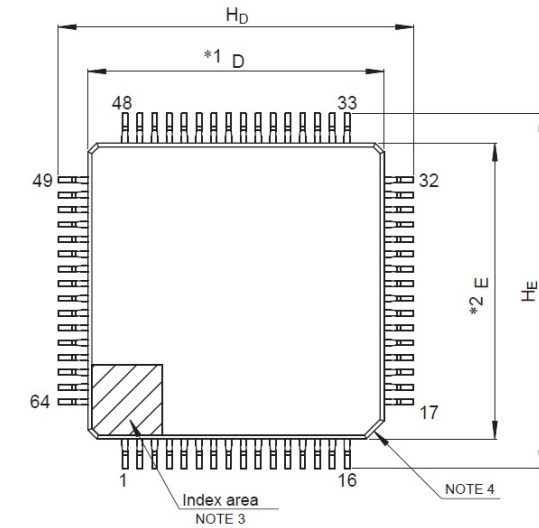

NOTE)

- DIMENSIONS “*1” AND “*2” DO NOT INCLUDE MOLD FLASH.
- DIMENSION “*3” DOES NOT INCLUDE TRIM OFFSET.
- PIN 1 VISUAL INDEX FEATURE MAY VARY, BUT MUST BE LOCATED WITHIN THE HATCHED AREA.
- CHAMFERS AT CORNERS ARE OPTIONAL, SIZE MAY VARY.

Reference Symbol	Dimensions in millimeters		
	Min	Nom	Max
D	9.9	10.0	10.1
E	9.9	10.0	10.1
A ₂	—	1.4	—
H _D	11.8	12.0	12.2
H _E	11.8	12.0	12.2
A	—	—	1.7
A ₁	0.05	—	0.15
b _p	0.15	0.20	0.27
c	0.09	—	0.20
θ	0°	3.5°	8°
e	—	0.5	—
x	—	—	0.08
y	—	—	0.08
L _p	0.45	0.6	0.75
L ₁	—	1.0	—

© 2015 Renesas Electronics Corporation. All rights reserved.

JEITA Package code	RENESAS code	MASS(TYP.)[g]
P-LFQFP064-10x10-0.50	PLQP0064KL-A	0.36

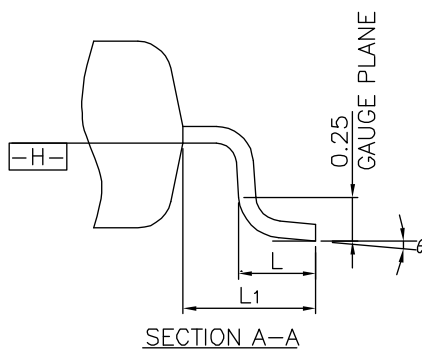
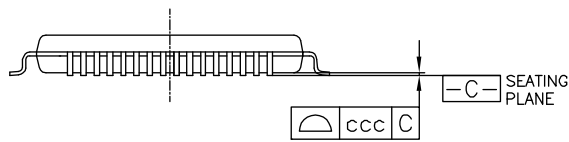
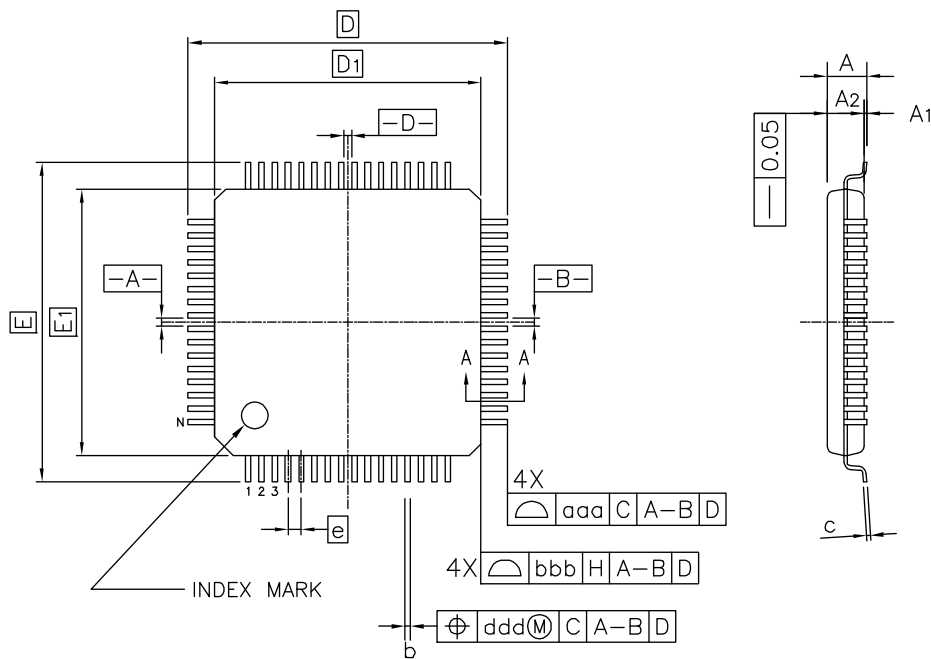

Reference Symbol	Dimension in Millimeters		
	Min.	Nom.	Max.
A	—	—	1.60
A ₁	0.05	—	0.15
A ₂	1.35	1.40	1.45
D	—	12.00	—
D ₁	—	10.00	—
E	—	12.00	—
E ₁	—	10.00	—
N	—	64	—
e	—	0.50	—
b	0.17	0.22	0.27
c	0.09	—	0.20
θ	0°	3.5°	7°
L	0.45	0.60	0.75
L ₁	—	1.00	—
aaa	—	—	0.20
bbb	—	—	0.20
ccc	—	—	0.08
ddd	—	—	0.08

JEITA Package Code	RENESAS Code	Previous Code	MASS (TYP.) [g]
P-VFBGA64-4x4-0.40	PVBG0064LA-A	P64F1-40-AA2-2	0.03

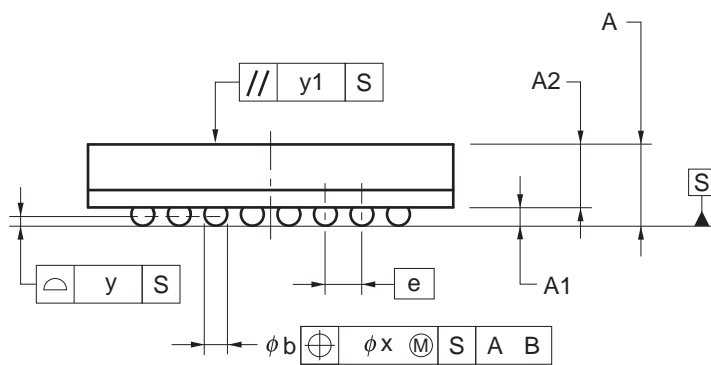
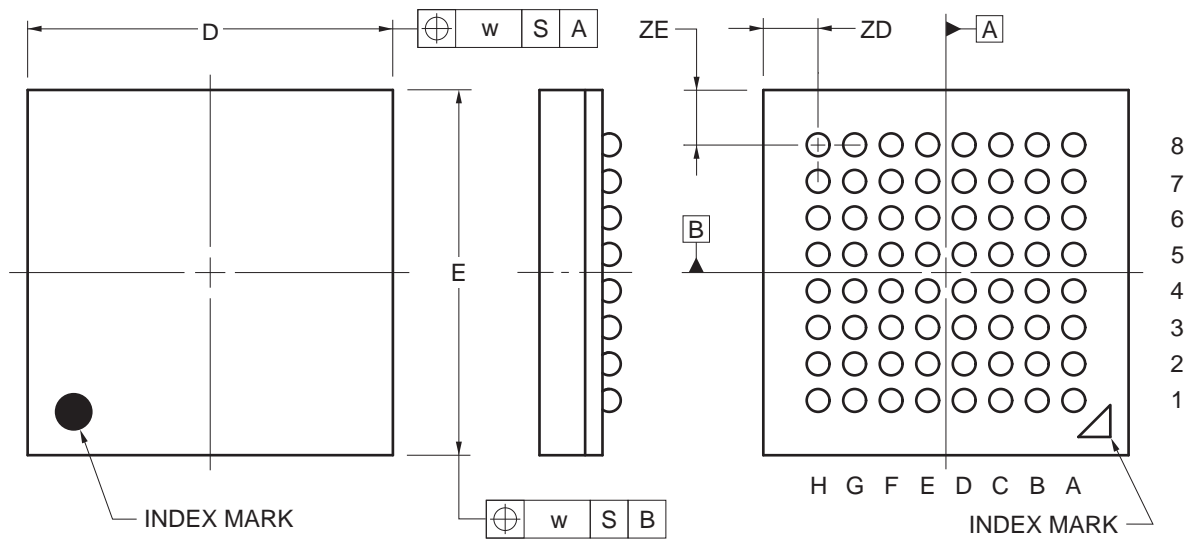

(UNIT:mm)

ITEM	DIMENSIONS
D	4.00±0.10
E	4.00±0.10
w	0.15
A	0.89±0.10
A1	0.20±0.05
A2	0.69
e	0.40
b	0.25±0.05
x	0.05
y	0.08
y1	0.20
ZD	0.60
ZE	0.60

©2012 Renesas Electronics Corporation. All rights reserved.

31.12 80-pin Package

JEITA Package Code	RENESAS Code	Previous Code	MASS (TYP) [g]
P-LQFP80-14x14-0.65	PLQP0080JB-E	P80GC-65-UBT-2	0.69

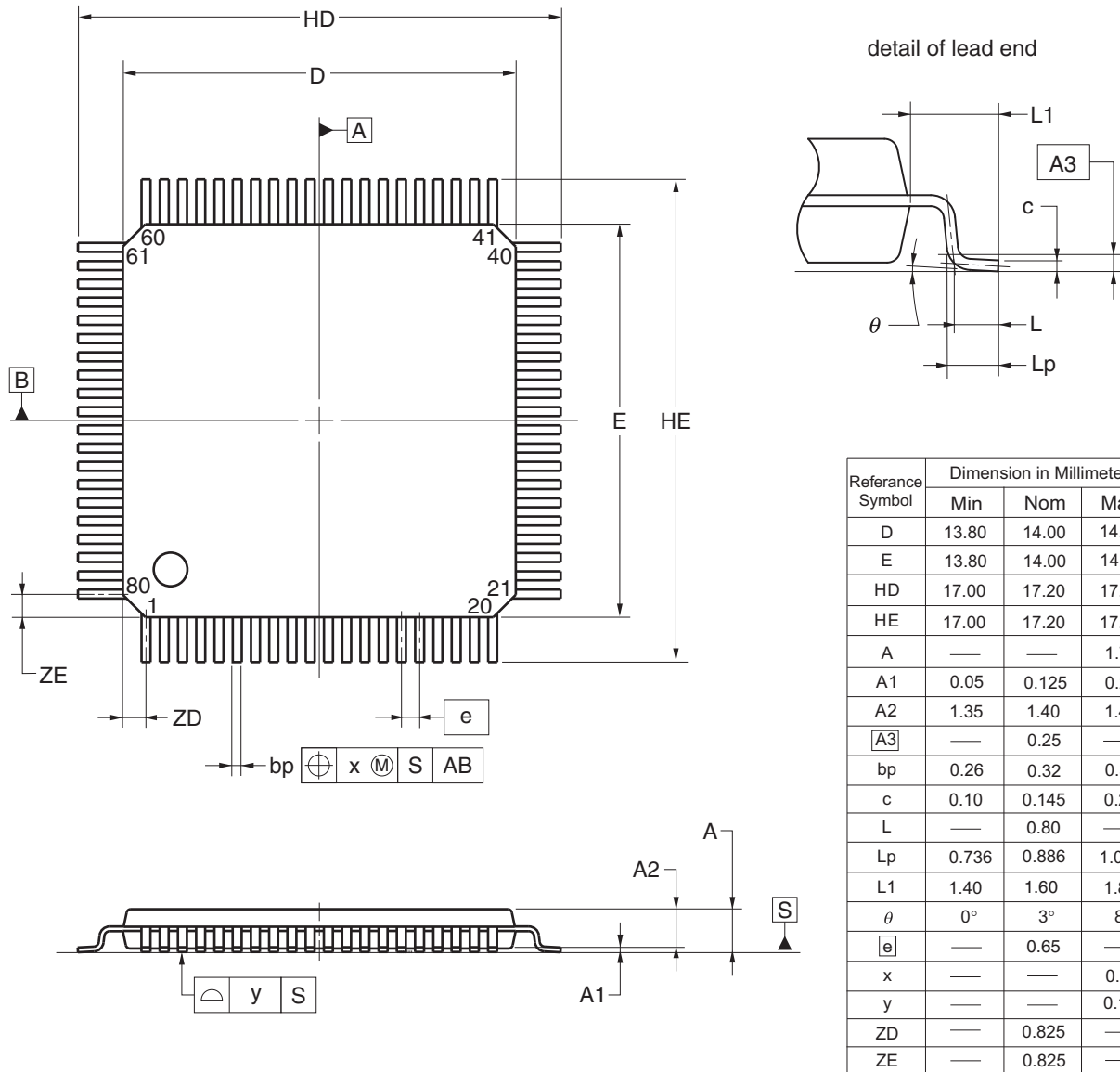

© 2012 Renesas Electronics Corporation. All rights reserved.

JEITA Package Code	RENESAS Code	Previous Code	MASS (TYP.) [g]
P-LFQFP80-12x12-0.50	PLQP0080KE-A	P80GK-50-8EU-2	0.53

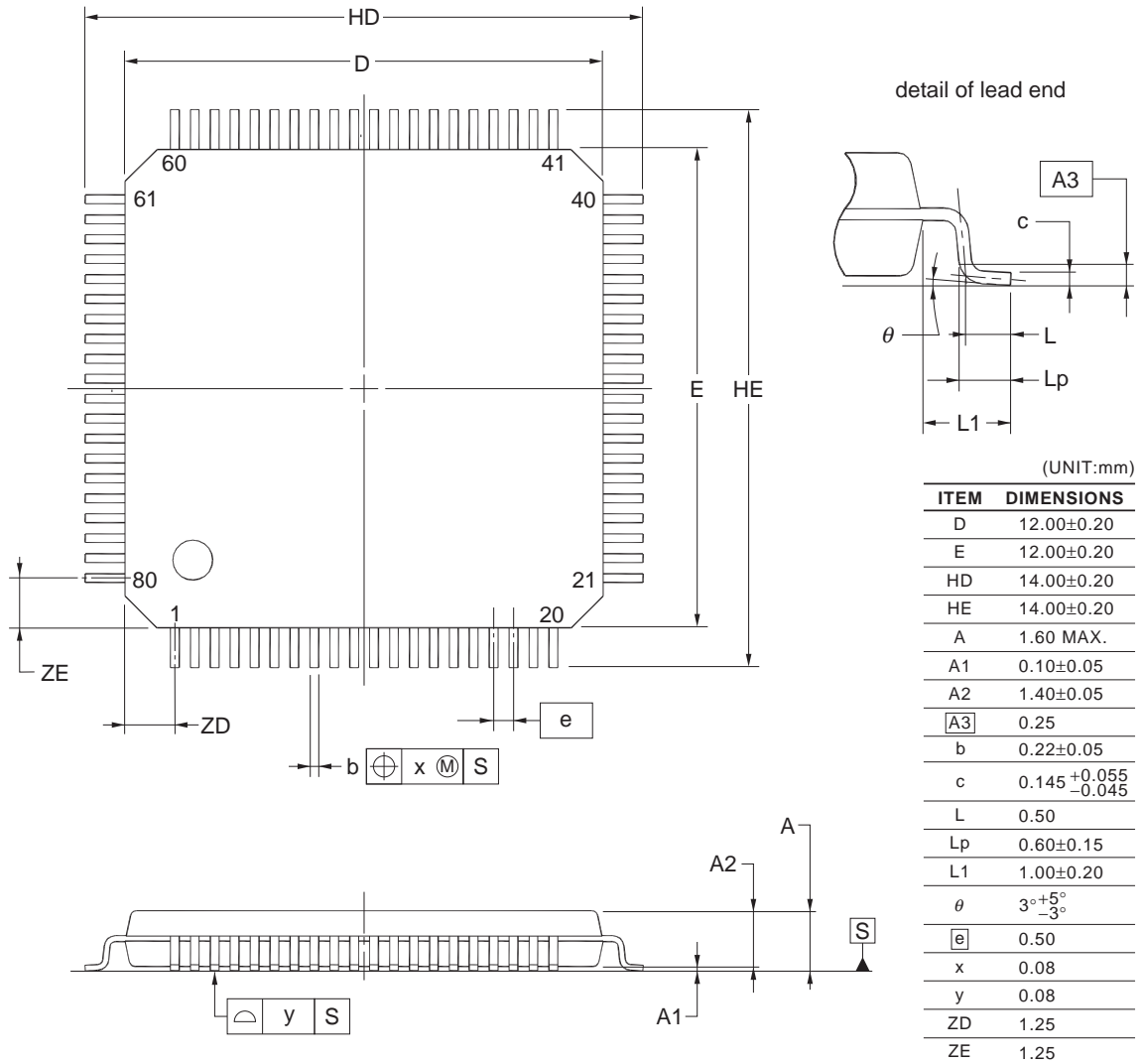

NOTE
 Each lead centerline is located within 0.08 mm of its true position at maximum material condition.

©2012 Renesas Electronics Corporation. All rights reserved.

JEITA Package Code	RENESAS Code	Previous Code	MASS (Typ) [g]
P-LFQFP80-12x12-0.50	PLQP0080KB-B	—	0.5

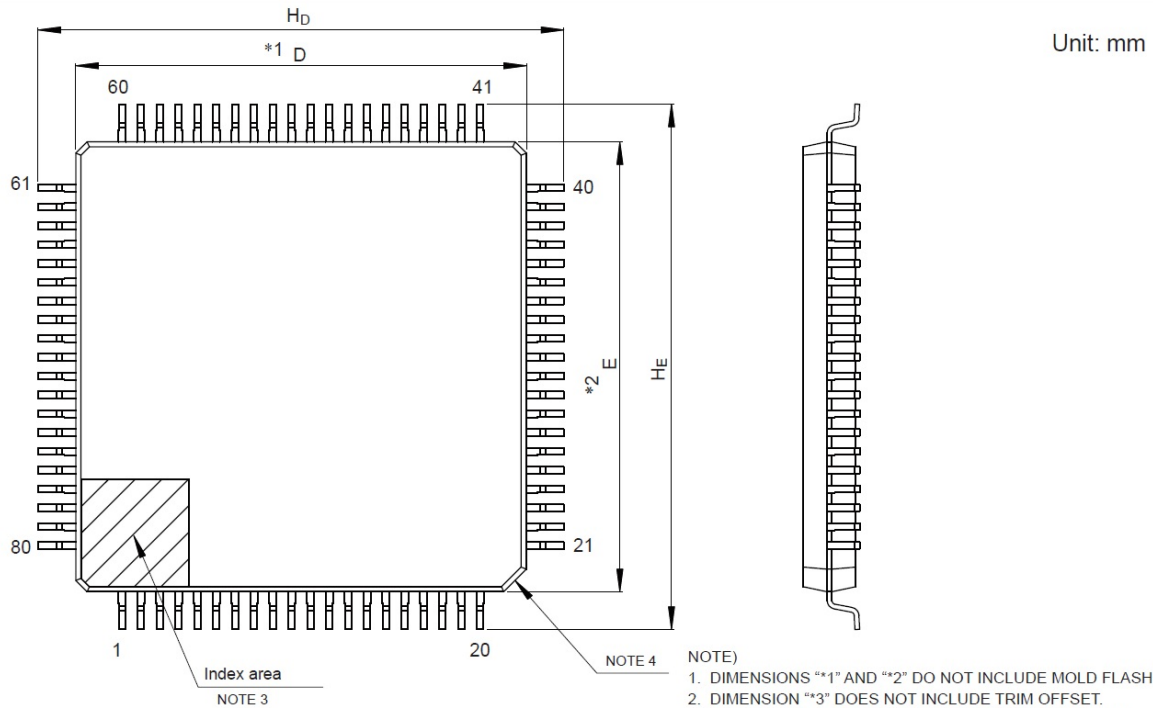

- NOTE)
1. DIMENSIONS “*1” AND “*2” DO NOT INCLUDE MOLD FLASH.
 2. DIMENSION “*3” DOES NOT INCLUDE TRIM OFFSET.
 3. PIN 1 VISUAL INDEX FEATURE MAY VARY, BUT MUST BE LOCATED WITHIN THE HATCHED AREA.
 4. CHAMFERS AT CORNERS ARE OPTIONAL, SIZE MAY VARY.

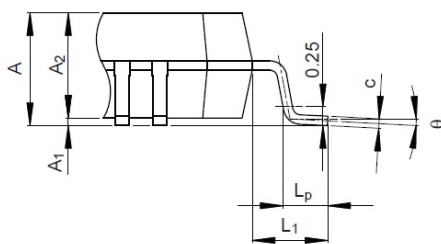
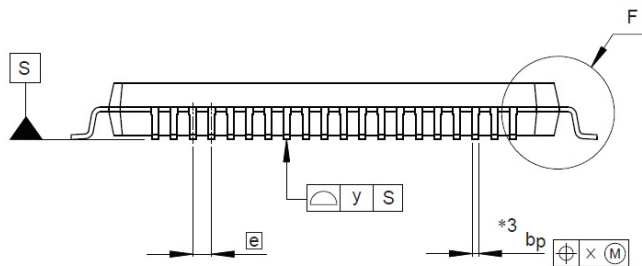

Detail F

Reference Symbol	Dimensions in millimeters		
	Min	Nom	Max
D	11.9	12.0	12.1
E	11.9	12.0	12.1
A ₂	—	1.4	—
H _D	13.8	14.0	14.2
H _E	13.8	14.0	14.2
A	—	—	1.7
A ₁	0.05	—	0.15
b _p	0.15	0.20	0.27
c	0.09	—	0.20
θ	0°	3.5°	8°
e	—	0.5	—
x	—	—	0.08
y	—	—	0.08
L _p	0.45	0.6	0.75
L ₁	—	1.0	—

© 2017 Renesas Electronics Corporation. All rights reserved.

JEITA Package code	RENESAS code	MASS(TYP.)[g]
P-LFQFP80-12x12-0.50	PLQP0080KJ-A	0.49

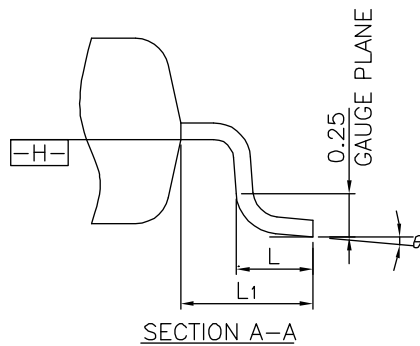
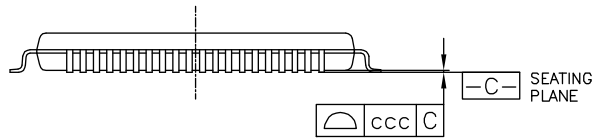
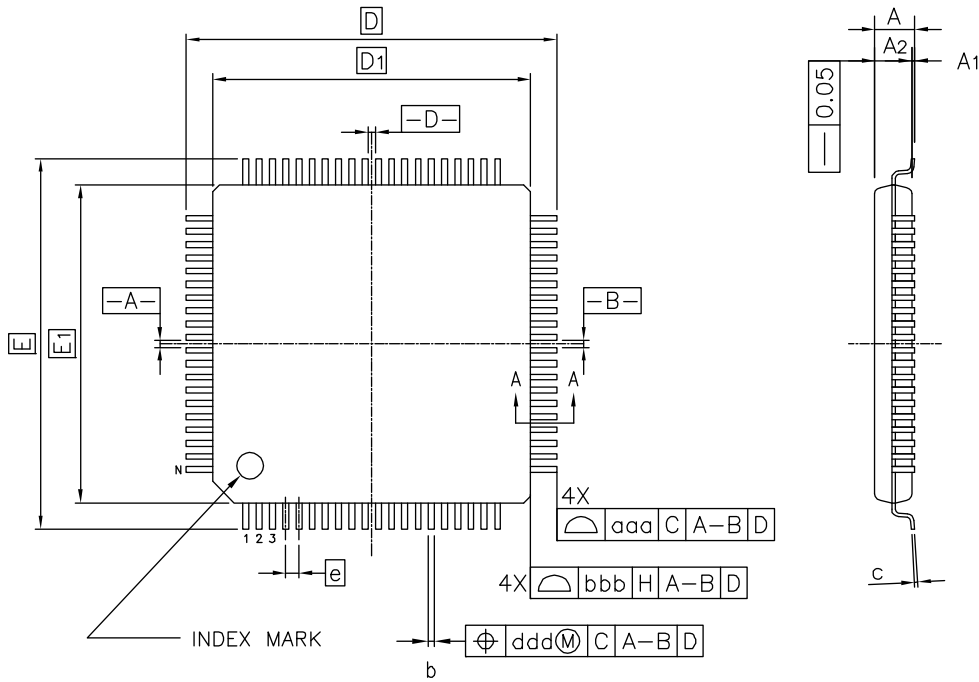

Reference Symbol	Dimension in Millimeters		
	Min.	Nom.	Max.
A	—	—	1.60
A ₁	0.05	—	0.15
A ₂	1.35	1.40	1.45
D	—	14.00	—
D ₁	—	12.00	—
E	—	14.00	—
E ₁	—	12.00	—
N	—	80	—
e	—	0.50	—
b	0.17	0.22	0.27
c	0.09	—	0.20
θ	0°	3.5°	7°
L	0.45	0.60	0.75
L ₁	—	1.00	—
aaa	—	—	0.20
bbb	—	—	0.20
ccc	—	—	0.08
ddd	—	—	0.08

31.13 100-pin Package

JEITA Package Code	RENESAS Code	Previous Code	MASS (TYP.) [g]
P-LFQFP100-14x14-0.50	PLQP0100KE-A	P100GC-50-GBR-1	0.69

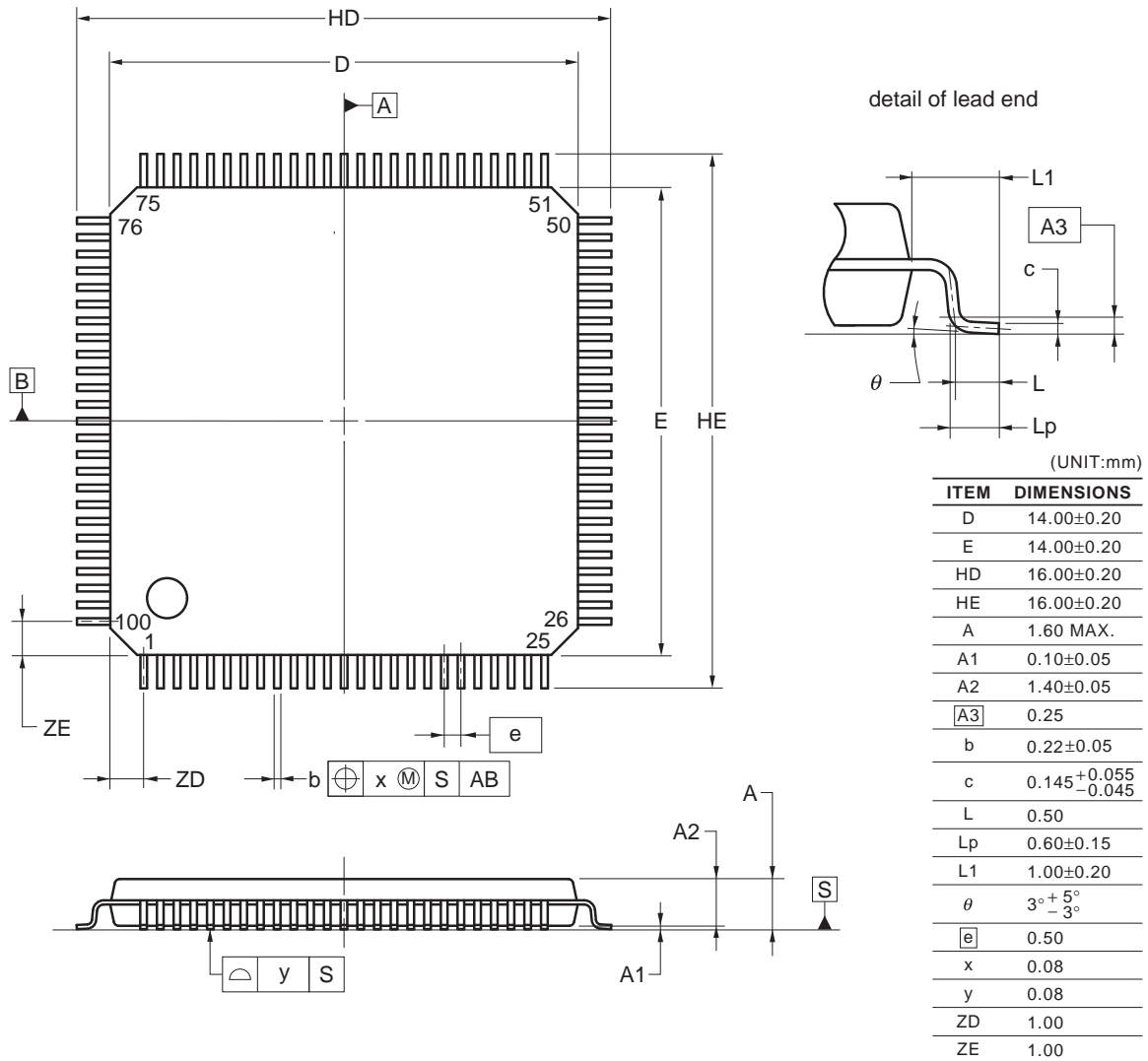

© 2012 Renesas Electronics Corporation. All rights reserved.

JEITA Package Code	RENESAS Code	Previous Code	MASS (Typ) [g]
P-LFQFP100-14x14-0.50	PLQP0100KB-B	—	0.6

Unit: mm

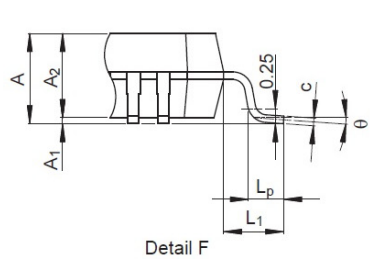
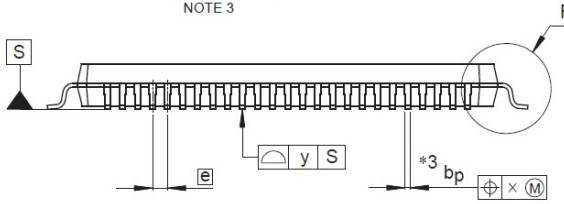
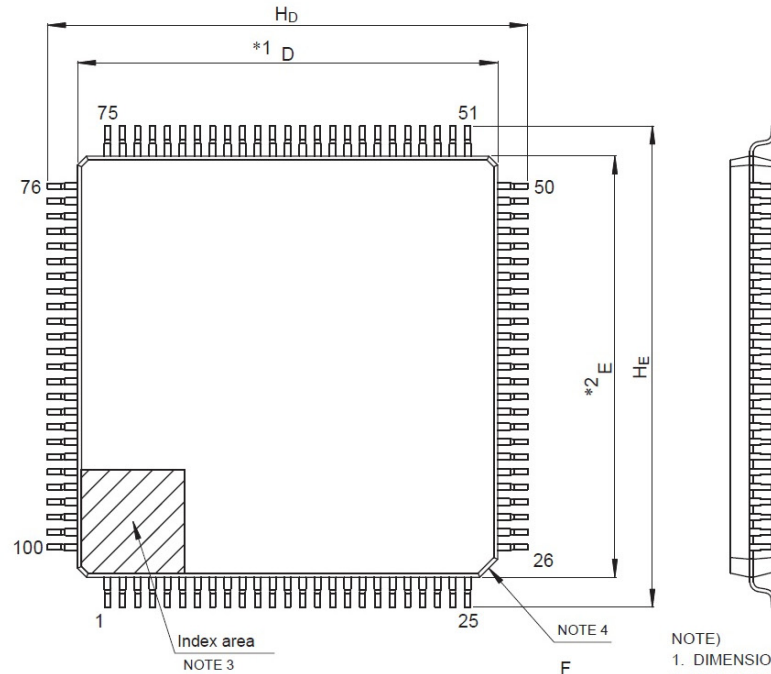

- NOTE)
1. DIMENSIONS **1" AND **2" DO NOT INCLUDE MOLD FLASH.
 2. DIMENSION **3" DOES NOT INCLUDE TRIM OFFSET.
 3. PIN 1 VISUAL INDEX FEATURE MAY VARY, BUT MUST BE LOCATED WITHIN THE HATCHED AREA.
 4. CHAMFERS AT CORNERS ARE OPTIONAL, SIZE MAY VARY.

Reference Symbol	Dimensions in millimeters		
	Min	Nom	Max
D	13.9	14.0	14.1
E	13.9	14.0	14.1
A ₂	—	1.4	—
H _D	15.8	16.0	16.2
H _E	15.8	16.0	16.2
A	—	—	1.7
A ₁	0.05	—	0.15
b _p	0.15	0.20	0.27
c	0.09	—	0.20
θ	0°	3.5°	8°
e	—	0.5	—
x	—	—	0.08
y	—	—	0.08
L _p	0.45	0.6	0.75
L ₁	—	1.0	—

© 2015 Renesas Electronics Corporation. All rights reserved.

JEITA Package code	RENESAS code	MASS(TYP.)[g]
P-LFQFP100-14x14-0.50	PLQP0100KP-A	0.67

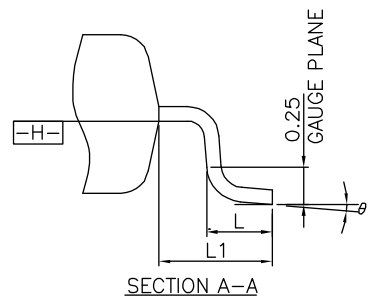
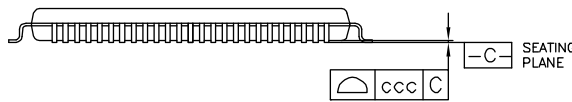
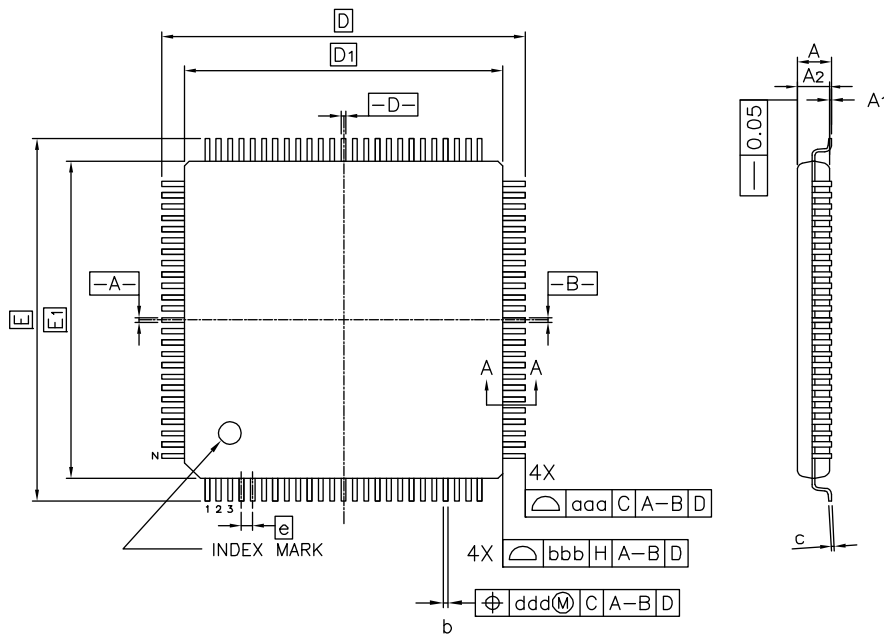

Reference Symbol	Dimension in Millimeters		
	Min.	Nom.	Max.
A	-	-	1.60
A ₁	0.05	-	0.15
A ₂	1.35	1.40	1.45
D	-	16.00	-
D ₁	-	14.00	-
E	-	16.00	-
E ₁	-	14.00	-
N	-	100	-
e	-	0.50	-
b	0.17	0.22	0.27
c	0.09	-	0.20
θ	0°	3.5°	7°
L	0.45	0.60	0.75
L ₁	-	1.00	-
aaa	-	-	0.20
bbb	-	-	0.20
ccc	-	-	0.08
ddd	-	-	0.08

JEITA Package Code	RENESAS Code	Previous Code	MASS (TYP.) [g]
P-LQFP100-14x20-0.65	PLQP0100JC-A	P100GF-65-GBN-1	0.92

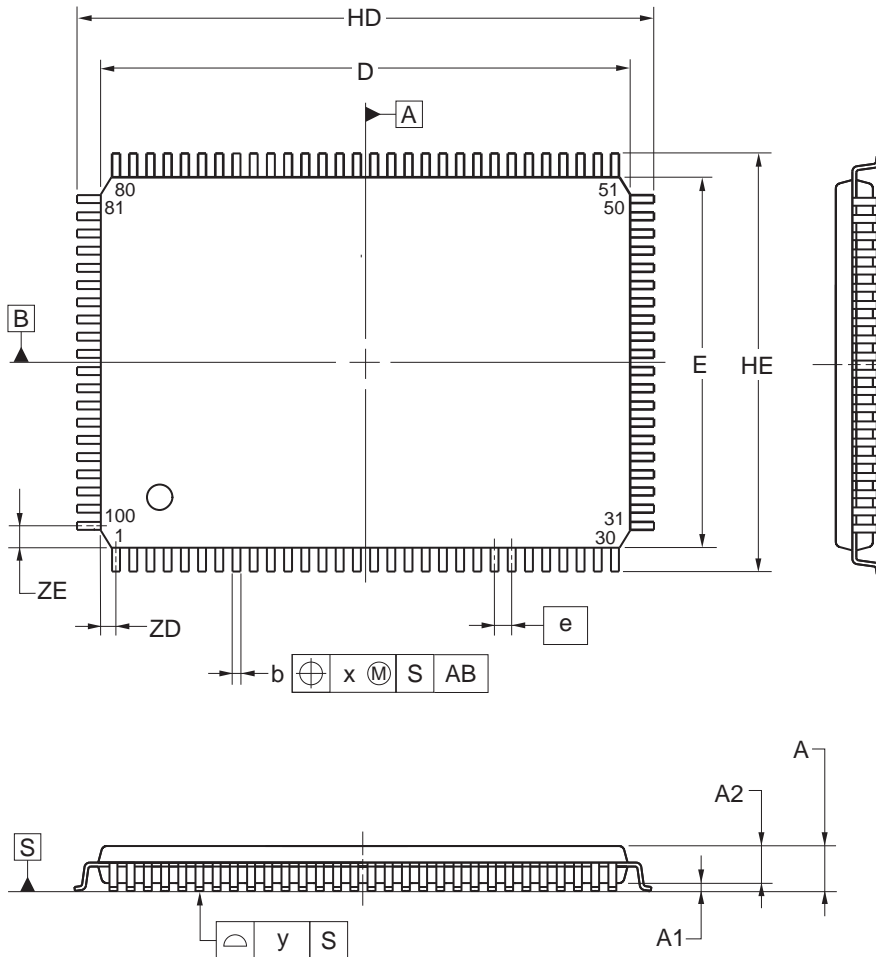

detail of lead end

(UNIT: mm)

ITEM	DIMENSIONS
D	20.00±0.20
E	14.00±0.20
HD	22.00±0.20
HE	16.00±0.20
A	1.60 MAX.
A1	0.10±0.05
A2	1.40±0.05
A3	0.25
b	0.32 ^{+0.08} _{-0.07}
c	0.145 ^{+0.055} _{-0.045}
L	0.50
Lp	0.60±0.15
L1	1.00±0.20
θ	3° ^{+5°} _{-3°}
e	0.65
x	0.13
y	0.10
ZD	0.575
ZE	0.825

© 2012 Renesas Electronics Corporation. All rights reserved.

31.14 128-pin Package

JEITA Package Code	RENESAS Code	Previous Code	MASS (TYP.) [g]
P-LFQFP128-14x20-0.50	PLQP0128KD-A	P128GF-50-GBP-1	0.92

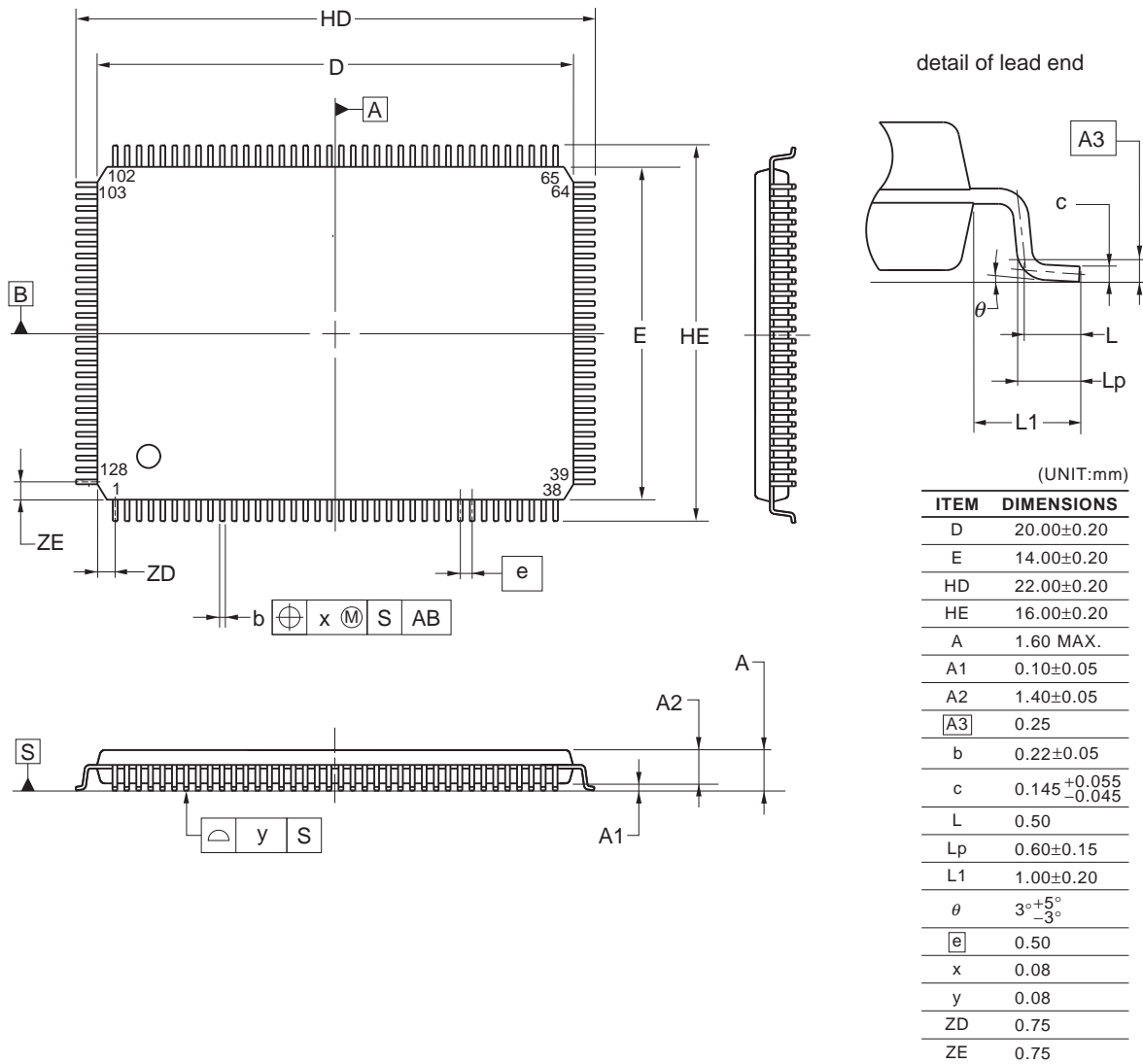

©2012 Renesas Electronics Corporation. All rights reserved.

APPENDIX A REVISION HISTORY

A.1 Major Revisions in This Edition

Page	Description	Classification
CHAPTER 1 OUTLINE		
p.7	Modification of Table 1-1. List of Ordering Part Numbers (3/8)	(d)
p.11	Modification of Table 1-1. List of Ordering Part Numbers (7/8)	(d)
CHAPTER 31 PACKAGE DRAWINGS		
p.1068	Addition of PLQP0044GF-A in 31.8 44-pin Package	(d)

Remark "Classification" in the above table classifies revisions as follows.

- (a): Error correction, (b): Addition/change of specifications, (c): Addition/change of description or note, (d): Addition/change of package, part number, or management division, (e): Addition/change of related documents

A.2 Revision History of Preceding Editions

Here is the revision history of the preceding editions. Chapter indicates the chapter of each edition.

(1/38)

Edition	Description	Chapter
Rev.3.70	Modification of description in Figure 1-1. Part Number, Memory Size, and Package of RL78/G13	CHAPTER 1 OUTLINE
	Modification of Table 1-1. List of Ordering Part Numbers (1/8) to (8/8)	
	Modification of description in 22.1 Overview of Safety Functions	CHAPTER 22 SAFETY FUNCTIONS
	Modification of description in 22.3.2 CRC operation function (general-purpose CRC)	
	Modification of description in 22.3.4 RAM guard function	
	Modification of description in 22.3.5 SFR guard function	
	Addition of package drawing in 31.7 40-pin Package	CHAPTER 31 PACKAGE DRAWINGS
	Addition of package drawing in 31.9 48-pin Package	
Rev.3.60	Modification of description in Figure 7-5. Format of Real-time Clock Control Register 1 (RTCC1) (2/2)	CHAPTER 7 REAL-TIME CLOCK
	Modification of Caution in Figure 7-21. Procedure for Reading Real-time Clock	
	Modification of Caution1 in Figure 7-22. Procedure for Writing Real-time Clock	
	Modification of Note 1 and Note 4 in 29.3.2 Supply current characteristics (1) Flash ROM: 16 to 64 KB of 20- to 64-pin products ($T_A = -40$ to $+85^\circ\text{C}$, $1.6\text{ V} \leq EV_{DD0} \leq V_{DD} \leq 5.5\text{ V}$, $V_{SS} = EV_{SS0} = 0\text{ V}$) (1/2)	CHAPTER 29 ELECTRICAL SPECIFICATIONS ($T_A = -40$ to $+85^\circ\text{C}$)
	Modification of Note 1 and Note 5, deletion of Note 6 in 29.3.2 Supply current characteristics (1) Flash ROM: 16 to 64 KB of 20- to 64-pin products ($T_A = -40$ to $+85^\circ\text{C}$, $1.6\text{ V} \leq EV_{DD0} \leq V_{DD} \leq 5.5\text{ V}$, $V_{SS} = EV_{SS0} = 0\text{ V}$) (2/2)	
	Modification of Note 1 and Note 4 in 29.3.2 Supply current characteristics (2) Flash ROM: 96 to 256 KB of 30- to 100-pin products ($T_A = -40$ to $+85^\circ\text{C}$, $1.6\text{ V} \leq EV_{DD0} = EV_{DD1} \leq V_{DD} \leq 5.5\text{ V}$, $V_{SS} = EV_{SS0} = EV_{SS1} = 0\text{ V}$) (1/2)	
	Modification of Note 1 and Note 5, deletion of Note 6 in 29.3.2 Supply current characteristics (2) Flash ROM: 96 to 256 KB of 30- to 100-pin products ($T_A = -40$ to $+85^\circ\text{C}$, $1.6\text{ V} \leq EV_{DD0} = EV_{DD1} \leq V_{DD} \leq 5.5\text{ V}$, $V_{SS} = EV_{SS0} = EV_{SS1} = 0\text{ V}$) (2/2)	
	Modification of Note 1 and Note 4 in 29.3.2 Supply current characteristics (3) 128-pin products, and flash ROM: 384 to 512 KB of 44- to 100-pin products ($T_A = -40$ to $+85^\circ\text{C}$, $1.6\text{ V} \leq EV_{DD0} = EV_{DD1} \leq V_{DD} \leq 5.5\text{ V}$, $V_{SS} = EV_{SS0} = EV_{SS1} = 0\text{ V}$) (1/2)	
	Modification of Note 1 and Note 5, deletion of Note 6 in 29.3.2 Supply current characteristics (3) 128-pin products, and flash ROM: 384 to 512 KB of 44- to 100-pin products ($T_A = -40$ to $+85^\circ\text{C}$, $1.6\text{ V} \leq EV_{DD0} = EV_{DD1} \leq V_{DD} \leq 5.5\text{ V}$, $V_{SS} = EV_{SS0} = EV_{SS1} = 0\text{ V}$) (2/2)	
	Modification of Note 1 and Note 4 in 30.3.2 Supply current characteristics (1) Flash ROM: 16 to 64 KB of 20- to 64-pin products ($T_A = -40$ to $+105^\circ\text{C}$, $2.4\text{ V} \leq EV_{DD0} \leq V_{DD} \leq 5.5\text{ V}$, $V_{SS} = EV_{SS0} = 0\text{ V}$) (1/2)	
	Modification of Note 1 and Note 5, deletion of Note 6 in 30.3.2 Supply current characteristics (1) Flash ROM: 16 to 64 KB of 20- to 64-pin products ($T_A = -40$ to $+105^\circ\text{C}$, $2.4\text{ V} \leq EV_{DD0} \leq V_{DD} \leq 5.5\text{ V}$, $V_{SS} = EV_{SS0} = 0\text{ V}$) (2/2)	
	Modification of Note 1 and Note 4 in 30.3.2 Supply current characteristics (2) Flash ROM: 96 to 256 KB of 30- to 100-pin products ($T_A = -40$ to $+105^\circ\text{C}$, $2.4\text{ V} \leq EV_{DD0} = EV_{DD1} \leq V_{DD} \leq 5.5\text{ V}$, $V_{SS} = EV_{SS0} = EV_{SS1} = 0\text{ V}$) (1/2)	
	Modification of Note 1 and Note 5, deletion of Note 6 in 30.3.2 Supply current characteristics (2) Flash ROM: 96 to 256 KB of 30- to 100-pin products ($T_A = -40$ to $+105^\circ\text{C}$, $2.4\text{ V} \leq EV_{DD0} = EV_{DD1} \leq V_{DD} \leq 5.5\text{ V}$, $V_{SS} = EV_{SS0} = EV_{SS1} = 0\text{ V}$) (2/2)	
	Modification of package drawing in 31.5 32-pin Package	CHAPTER 31 PACKAGE DRAWINGS

(2/38)

Edition	Description	Chapter	
Rev.3.51	3-Wire Serial I/O" and "3-wire serial" were modified to " Simplified SPI"	All	
	The module name for CSI was changed to Simplified SPI		
	"wait" for IIC was modified to "clock stretch"		
	Addition of Note 1 in 1 Features	CHAPTER 1 OUTLINE	
	Modification of Table 1-1 List of Ordering Part Numbers (1/8) to (8/8)		
	Addition of Note in 4.4.5 Handling different potential (1.8 V, 2.5 V, 3 V) by using I/O buffers	CHAPTER 4 PORT FUNCTIONS	
	Addition of Note in CHAPTER 12 SERIAL ARRAY UNIT	CHAPTER 12 SERIAL ARRAY UNIT	
	Addition of package drawing in 31.2 24-pin Package	CHAPTER 31 PACKAGE DRAWINGS	
	Addition of package drawing in 31.5 32-pin Package		
	Addition of package drawing in 31.8 44-pin Package		
	Addition of package drawing in 31.9 48-pin Package		
	Addition of package drawing in 31.10 52-pin Package		
	Addition of package drawing in 31.11 64-pin Package		
	Addition of package drawing in 31.12 80-pin Package		
Addition of package drawing in 31.13 100-pin Package			
Rev.3.50	Modification of description in 1.1 Features		CHAPTER 1 OUTLINE
	Modification of Figure 1-1 Part Number, Memory Size, and Package of RL78/G13		
	Modification of Table 1-1 List of Ordering Part Numbers		
	Addition of packaging specifications in 1.3.1 20-pin products		
	Modification of table in 2.1.4 30-pin products	CHAPTER 2 PIN FUNCTIONS	
	Modification of description in 10.1 Functions of Watchdog Timer	CHAPTER 10 WATCHDOG TIMER	
	Modification of description in 10.4.4 Setting watchdog timer interval interrupt		
	Modification of Table 10-5 Setting of Watchdog Timer Interval Interrupt		
	Modification of figure and note 1 in Figure 11-4 Timing Chart When A/D Voltage Comparator Is Used	CHAPTER 11 A/D CONVERTER	
	Modification of Figure 12-2 Block Diagram of Serial Array Unit 1	CHAPTER 12 SERIAL ARRAY UNIT	
	Modification of Figure 12-10 Format of Serial Flag Clear Trigger Register mn (SIRmn)		
	Modification of caution 1 in Figure 12-11 Format of Serial Status Register mn (SSRmn)		
	Modification of note 2 and caution in Figure 12-16 Format of Serial Output Register m (SOM)		
	Modification of Figure 12-19 Format of Serial Standby Control Register m (SSCm)		
	Modification of Figure 12-32 Flowchart of Master Transmission (in Continuous Transmission Mode)		
	Modification of Figure 12-83 Flowchart of UART Transmission (in Continuous Transmission Mode)		
	Modification of Figure 24-1 Format of User Option Byte (000C0H/010C0H)		CHAPTER 24 OPTION BYTE
	Addition of caution 4 in 25.8.3 Procedure for accessing data flash memory		CHAPTER 25 FLASH MEMORY
	Modification of the titles of the subchapters and deletion of product names in CHAPTER 31 PACKAGE DRAWINGS		CHAPTER 31 PACKAGE DRAWINGS
	Addition of package drawing in 31.1 20-pin Package		
	Addition of package drawing in 31.2 24-pin Package		
	Addition of package drawing in 31.5 32-pin Package		
	Addition of package drawing in 31.7 40-pin Package		
	Addition of package drawing in 31.8 44-pin Package		
	Addition of package drawing in 31.9 48-pin Package		
	Addition of package drawing in 31.11 64-pin Package		
	Addition of package drawing in 31.12 80-pin Package		
Addition of package drawing in 31.13 100-pin Package			

(3/38)

Edition	Description	Chapter
Rev.3.40	PG-FP6 has been added, FL-PR5 has been deleted, and description of E2, E2 Lite, and E20 has been added.	All
	Modification of Table 2-3 Connections of Unused Pins	CHAPTER 2 PIN FUNCTIONS
	Modification of caution in Figure 2-7 Pin Block Diagram for Pin Type 7-1-2	
	Modification of caution in Figure 2-9 Pin Block Diagram for Pin Type 7-3-2	
	Modification of caution in Figure 2-10 Pin Block Diagram for Pin Type 8-1-1	
	Modification of caution 1 in Figure 2-11 Pin Block Diagram for Pin Type 8-1-2	
	Modification of Figure 2-12 Pin Block Diagram for Pin Type 8-3-1	
	Modification of caution 1 in Figure 2-13 Pin Block Diagram for Pin Type 8-3-2	
	Modification of description in 3.2.3 ES and CS registers	CHAPTER 3 CPU ARCHITECTURE
	Modification of title and description in 3.3.4 Register indirect addressing	
	Modification of title in Figure 3-23 Outline of Register Indirect Addressing	
	Modification of remark in Figure 5-13 Examples of Incorrect Resonator Connection	CHAPTER 5 CLOCK GENERATOR
	Modification of description in 5.4.4 Low-speed on-chip oscillator	
	Modification of cautions 1 and 2 in Figure 7-4 Format of Real-time Clock Control Register 0 (RTCC0)	CHAPTER 7 REAL-TIME CLOCK
	Addition of note in Table 10-3 Setting of Overflow Time of Watchdog Timer	CHAPTER 11 A/D CONVERTER
	Addition of note in Table 10-4 Setting Window Open Period of Watchdog Timer	
	Modification of Table 10-5 Setting of Watchdog Timer Interval Interrupt	
	Modification of Figure 11-25 Example of Hardware Trigger Wait Mode (Select Mode, Sequential Conversion Mode) Operation Timing	
	Modification of Figure 12-44 Procedure for Resuming Master Transmission/Reception	CHAPTER 12 SERIAL ARRAY UNIT
	Modification of note 2 in Figure 12-84 Example of Contents of Registers for UART Reception of UART (UART0 to UART3) (1/2)	
	Modification of Figure 12-87 Procedure for Resuming UART Reception	
	Modification of Figure 12-98 Transmission Operation of LIN	
	Modification of Figure 12-99 Flowchart for LIN Transmission	
	Modification of Figure 12-100 Reception Operation of LIN	
	Modification of Figure 12-101 Flowchart for LIN Reception	
	Modification of Figure 13-4 Format of Slave Address Register n (SVAn)	CHAPTER 13 SERIAL INTERFACE IICA
	Modification of description in 13.5.17 Timing of I ² C interrupt request (INTIICAn) occurrence (c) Start ~ Code ~ Data ~ Data ~ Stop (extension code transmission) (ii) When WTIMn = 1	
	Deletion of note 3 in Table 16-1 Interrupt Source List (3/4)	CHAPTER 16 INTERRUPT FUNCTIONS
	Modification of description in 16.3.3 Priority specification flag registers (PR00L, PR00H, PR01L, PR01H, PR02L, PR02H, PR03L, PR10L, PR10H, PR11L, PR11H, PR12L, PR12H, PR13L)	
	Modification of description in 16.4.3 Multiple interrupt servicing	
	Modification of caution 5 in 18.1 Standby Function	CHAPTER 18 STANDBY FUNCTION
	Modification of Figure 18-5 When the Interrupt Request Signal is Generated in the SNOOZE Mode	
	Modification of Figure 18-6 When the Interrupt Request Signal is not Generated in the SNOOZE Mode	

(4/38)

Edition	Description	Chapter
Rev.3.40	Modification of Figure 22-15 Configuration of A/D Test Function	CHAPTER 22 SAFETY FUNCTIONS
	Addition of note 3 in Figure 24-1 Format of User Option Byte (000C0H/010C0H)	CHAPTER 24 OPTION BYTE
	Modification of Figure 25-4 Communication with External Device	CHAPTER 25 FLASH MEMORY
	Addition of note in 30.6.3 POR circuit characteristics	CHAPTER 30 ELECTRICAL SPECIFICATIONS (G: INDUSTRIAL APPLICATIONS $T_A = -40$ to $+105^{\circ}\text{C}$)
Rev.3.30	Wording changed from "Input/output can be specified" to "Input/output can be specified in 1-bit units".	All
	Modification of the position of the index mark in 25-pin plastic WFLGA (3 × 3 mm, 0.50 mm pitch) of 1.3.3 25-pin products	CHAPTER 1 OUTLINE
	Modification of power supply voltage in 1.6 Outline of Functions [20-pin, 24-pin, 25-pin, 30-pin, 32-pin, 36-pin products]	
	Modification of power supply voltage in 1.6 Outline of Functions [40-pin, 44-pin, 48-pin, 52-pin, 64-pin products]	
	Modification of power supply voltage in 1.6 Outline of Functions [80-pin, 100-pin, 128-pin products]	
	Modification of function of P137 in 2.1.4 30-pin products	
	Addition of caution in Figure 2-7 Pin Block Diagram for Pin Type 7-1-2	CHAPTER 2 PIN FUNCTIONS
	Addition of caution in Figure 2-9 Pin Block Diagram for Pin Type 7-3-2	
	Addition of caution in Figure 2-10 Pin Block Diagram for Pin Type 8-1-1	
	Addition of cautions 1 and 2 in Figure 2-11. Pin Block Diagram for Pin Type 8-1-2	
	Addition of caution in Figure 2-12 Pin Block Diagram for Pin Type 8-3-1	
	Addition of cautions 1 and 2 in Figure 2-13 Pin Block Diagram for Pin Type 8-3-2	
	Addition of caution in Figure 2-14 Pin Block Diagram for Pin Type 12-1-1	
	Modification of vector table addresses in Tables 3-3 and 3-4 Vector Table	
	Modification of addresses (00000H and 00001H) in 3.2.1 Control registers	
	Addition of F0139H 2 in Table 3-6. Extended SFR (2nd SFR) List (3/8)	
	Modification of description in (1) Main system clock of 5.1 Functions of Clock Generator	CHAPTER 5 CLOCK GENERATOR
	Modification of caution 6 in Figure 5-4 Format of Clock Operation Status Control Register (CSC)	
	Modification of description in Table 5-4 Changing CPU Clock (1/2)	
	Modification of description in Table 5-4 Changing CPU Clock (2/2)	
	Modification of description in 5.6.7 Conditions before clock oscillation is stopped	
	Addition of remark 2 in (1) X1 oscillation of 5.7 Resonator and Oscillator Constants	
	Addition of remark in (2) XT1 oscillation: Crystal resonator of 5.7 Resonator and Oscillator Constants	
	Modification of description in 6.2.2 Timer data register mn (TDRmn)	
	Modification of description in Figure 6-11 Format of Timer Mode Register mn (TMRmn)	
	Modification of description in 6.4.2 Basic rules of 8-bit timer operation function (channels 1 and 3 only)	
	Modification of description in 6.8.2 Operation as external event counter	
	Addition of notes 1 and 2 in Figure 7-5 Format of Real-time Clock Control Register 1 (RTCC1) (2/2)	CHAPTER 7 REAL-TIME CLOCK
	Modification of Figure 11-4 Timing Chart When A/D Voltage Comparator Is Used	CHAPTER 11 A/D CONVERTER
	Modification of Figure 11-29 Setting up Software Trigger Mode	
	Modification of Figure 11-30 Setting up Hardware Trigger No-Wait Mode	

(5/38)

Edition	Description	Chapter
Rev.3.30	Modification of Figure 11-31 Setting up Hardware Trigger Wait Mode	CHAPTER 11 A/D CONVERTER
	Modification of Figure 11-32 Setup when temperature sensor output voltage/internal reference voltage is selected	
	Modification of Figure 11-33 Setting up Test Mode	
	Modification of Figure 11-37 Flowchart for Setting up SNOOZE Mode	
	Modification of note 2 in Figure 12-16 Format of Serial Output Register m (SOM)	CHAPTER 12 SERIAL ARRAY UNIT
	Modification of Figure 12-87 Procedure for Resuming UART Reception	
	ACK corrected to ACK	CHAPTER 13 SERIAL INTERFACE IICA
	Modification of description in Figure 13-9 Format of IICA Control Register n1 (IICCTLn1) (2/2)	
	Modification of description in 13.3.6 IICA low-level width setting register n (IICWLn)	
	Modification of description in 15.1 Functions of DMA Controller	CHAPTER 15 INTERRUPT FUNCTIONS
	Modification of vector table addresses in Table 16-1 Interrupt Source List	CHAPTER 16 INTERRUPT FUNCTIONS
	Modification of caution 4 in Table 16-2 Flags Corresponding to Interrupt Request Sources (2/4)	
	Modification of address (00000H and 00001H)	CHAPTER 19 RESET FUNCTION
	Modification of address in Table 19-2 State of Hardware After Receiving a Reset Signal	
	Modification of description in 21.1 Functions of Voltage Detector	CHAPTER 21 VOLTAGE DETECTOR
	Modification of error in 21.4.3 When used as interrupt & reset mode	
	Modification of signal name in Table 25-1 Wiring between RL78/G13 and Dedicated Flash Memory Programmer	CHAPTER 25 FLASH MEMORY
	Addition of note in Table 26-1 On-Chip Debug Security ID	CHAPTER 26 ON-CHIP DEBUG FUNCTION
ACK corrected to ACK	CHAPTER 29 ELECTRICAL SPECIFICATIONS (TA = -40 to +85°C)	
ACK corrected to ACK	CHAPTER 30 ELECTRICAL SPECIFICATIONS (G: INDUSTRIAL APPLICATIONS TA = -40 to +105°C)	
Rev.3.20	Modification of note of ROM, RAM capacities	CHAPTER 1 OUTLINE
	Addition of G to fields of application in Table 1-1 List of Ordering Part Numbers	
	Modification of package and fields of application in Table 1-1 List of Ordering Part Numbers	
	Addition of description to 1.3.1 20-pin products to 1.3.14 128-pin products	
	Modification of description and note 1 in 1.6 Outline of Functions	
	Modification of Figure 2-3 Pin Block Diagram for Pin Type 2-1-2	CHAPTER 2 PIN FUNCTIONS
	Modification of note 1 of Figures 3-1 to 3-10 Memory Map	CHAPTER 3 CPU ARCHITECTURE
	Modification of cautions 2 and 3 in 3.1.3 Internal data memory space	
	Modification of cautions 2 and 3 in (3) Stack pointer (SP)	
	Modification of description in Figure 3-43 Example of CALL, CALLT	

(6/38)

Edition	Description	Chapter	
Rev.3.20	Modification of note 1 in 4.2.8 Port 7	CHAPTER 4 PORT FUNCTIONS	
	Modification of setting of RxD3 of P143 in Table 4-7 Setting Examples of Registers and Output Latches When Using Alternate Function (19/21)		
	Addition of register setting <5> in 5.6.2 Example of setting X1 oscillation clock	CHAPTER 5 CLOCK GENERATOR	
Addition of note 4 to (1) X1 oscillation (1/2)			
Rev.3.20	Modification of description in Figures 6-4 and 6-5	CHAPTER 6 TIMER ARRAY UNIT	
	Modification of caution in Figure 6-16		
Rev.3.20	Modification of description in 9.5 Cautions of clock output/buzzer output controller	CHAPTER 9 CLOCK OUTPUT/BUZZER OUTPUT CONTROLLER	
	Modification of Figure 12-18 Examples of Reverse Transmit Data		
Rev.3.20	Modification of description in 12.5.7 SNOOZE mode function	CHAPTER 12 SERIAL ARRAY UNIT	
	Modification of Figure 12-71 Timing Chart of SNOOZE Mode Operation (once startup) (Type 1: DAPmn = 0, CKPmn = 0)		
	Modification of Figure 12-73 Timing Chart of SNOOZE Mode Operation (continuous startup) (Type 1: DAPmn = 0, CKPmn = 0)		
	Modification of Table 12-2 Selection of Operation Clock For 3-Wire Serial I/O		
	Addition of caution 5 to 12.6.3 SNOOZE mode function		
	Modification of Figure 12-90 Timing Chart of SNOOZE Mode Operation (EOCm1 = 0, SSECm = 0/1)		
	Modification of Figure 12-91 Timing Chart of SNOOZE Mode Operation (EOCm1 = 1, SSECm = 0)		
	Modification of Figure 12-93 Timing Chart of SNOOZE Mode Operation (EOCm1 = 1, SSECm = 1)		
	Modification of description in 13.5.14 Communication reservation		CHAPTER 13 SERIAL INTERFACE IICA
	Modification of caution1 in Figure 13-27 Communication Reservation Protocol		
	Modification of Figure 13-28 Master Operation in Single-Master System		
Modification of Figure 13-29 Master Operation in Multi-Master System (1/3)			
Rev.3.20	Modification of note in Figure 13-29 Master Operation in Multi-Master System (1/3)	CHAPTER 13 SERIAL INTERFACE IICA	
	Modification of Figure 13-30 Slave Operation Flowchart (1)		
Rev.3.20	Addition of description to 15.6 Cautions on Using DMA Controller	CHAPTER 15 DMA CONTROLLER	
	Modification of Table 16-5		
Rev.3.20	Modification of Figure 20-2 (1)	CHAPTER 20 POWER-ON-RESET CIRCUIT	
	Modification of description of Interrupt mode (LVIMDS1, LVIMDS0 = 0, 1)		
Rev.3.20	Modification of description in Figure 25-7	CHAPTER 25 FLASH MEMORY	
	Addition of description to 25.8.3 Procedure for accessing data flash memory		
Rev.3.20	Addition of addr5 to Table 28-2	CHAPTER 28 INSTRUCTION SET	

(7/38)

Edition	Description	Chapter
Rev.3.20	Addition of target products to the beginning	CHAPTER 29 ELECTRICAL SPECIFICATIONS (T _A = -40 to +85°C)
	Addition of target products to note 4 in 29.3.1 Pin characteristics (1/5)	
	Modification of conditions of SIp setup time	
	Renamed to 29.7 RAM Data Retention Characteristics, and modification of note and figure	
	Modification of figure in 29.10 Timing Specs for Switching Flash Memory Programming Modes	
	Addition of target products to the beginning	CHAPTER 30 ELECTRICAL SPECIFICATIONS (G: INDUSTRIAL APPLICATIONS T _A = - 40 to +105°C)
	Modification of conditions of SIp setup time	
	Renamed to 30.7 RAM Data Retention Characteristics, and modification of note and figure	
	Modification of figure in 30.10 Timing Specs for Switching Flash Memory Programming Modes	
	Modification of part number in 31.2 24-pin Products	CHAPTER 31 PACKAGE DRAWINGS
	Modification of part number in 31.3 25-pin Products	
	Modification of figure in 31.5 32-pin Products	
	Modification of part number of 31.6 36-pin Products	
	Modification of figure in 31.7 40-pin Products	
	Modification of figure in 31.9 48-pin Products	
Modification of figure in 31.11 64-pin Products		
Rev.3.10	Caution 4 added.	CHAPTER 30 ELECTRICAL SPECIFICATIONS (G: T _A = -40 to +105°C)
	Note for operating ambient temperature in 30. 1 Absolute Maximum Ratings deleted.	
Rev.3.00	Modification of 1.1 Features	CHAPTER 1 OUTLINE
	Modification of 1.2 List of Part Numbers	
	Modification of Table 1-1. List of Ordering Part Numbers, note, and caution	
	Modification of package type in 1.3.1 to 1.3.14	
	Modification of description in 1.4 Pin Identification	
	Modification of caution, table, and note in 1.6 Outline of Functions	
	Modification of caution in 2.1 Port Function	CHAPTER 2 PIN FUNCTIONS
	Modification of table and remark in 2.1.1 to 2.1.14	
	Modification of table in 2.3 Connection of Unused Pins	
	Modification of Figures 2-1 to 2-14 in 2.4 Block Diagrams of Pins	
	Modification of notes 1 and 5 in Figures 3-1 to 3-10 in 3.1 Memory Space	CHAPTER 3 CPU ARCHITECTURE
	Modification of remark in Table 3-1	
	Modification of description in 3.1.2 Mirror area	
	Modification of cautions 2 and 3 in 3.1.3 Internal data memory space	
	Integration of Figures 3-12 to 3-21 into Figure 3-12 in 3.1.6 Data memory addressing	
	Modification of error and cautions 3 and 4 in 3.2.1 (3) Stack pointer (SP)	
	Modification of error in 3.2.3 ES and CS registers	
	Modification of description in Table 3-5	
	Modification of note 2 in Table 3-6	
	Modification of description in Table 4-1	
Modification of description in 4.2.1 Port 0		
Modification of description in 4.2.3 Port 2		

(8/38)

Edition	Description	Chapter
Rev.3.00	Modification of description in 4.2.4 Port 3 Modification of description in 4.2.11 Port 10 Modification of description in 4.2.12 Port 11 Modification of description in 4.2.13 Port 12 Modification of description in 4.2.15 Port 14 Modification of description in 4.2.16 Port 15 Modification of description in 4.3.1 Port mode registers (PMxx) Modification of caution in Figure 4-1 Modification of caution in Figure 4-2 Modification of description in 4.3.3 Pull-up resistor option registers (PUxx) Modification of caution in Figure 4-3 Modification of caution in 4.3.4 Port input mode registers (PIMxx) Modification of caution in 4.3.5 Port output mode registers (POMxx) Modification of description and caution in Figure 4-5 Modification of cautions 1 and 3 in Figure 4-6 in 4.3.6 Port mode control registers (PMCxx) Modification of remark in Figure 4-8 Modification of description in 4.3.9 Global digital input disable register (GDIDIS) Modification of cautions 1 and 2 and remarks 1 and 2 in Figure 4-9 Modification of description and remark in 4.4.4 Handling different potential (1.8 V, 2.5 V, 3 V) by using $EV_{DD} \leq V_{DD}$ Modification of description in 4.4.5 Handling different potential (1.8 V, 2.5 V, 3 V) by using I/O buffers Modification of description in 4.5 Register Settings When Using Alternate Function Modification of description in Table 4-7 Modification of description in 4.6.2 Notes on specifying the pin settings	CHAPTER 4 PORT FUNCTIONS
Rev.3.00	Modification of description in 5.1 Functions of Clock Generator Modification of description in 5.2 Configuration of Clock Generator Modification of description in 5.3 Registers Controlling Clock Generator Modification of caution 3 in Figure 5-2 Modification of caution 3 in Figure 5-3 Modification of description in Figure 5-5 Modification of description in 5.3.5 Oscillation stabilization time select register (OSTS) Modification of description in Figure 5-6 and caution 1 Modification of description in 5.3.7 Subsystem clock supply mode control register (OSMC) Modification of description in 5.3.8 High-speed on-chip oscillator frequency select register (HOCODIV) Modification of description in 5.4.3 High-speed on-chip oscillator Modification of description in 5.4.4 Low-speed on-chip oscillator Modification of description in Figure 5-14 Modification of description in 5.6.1 Example of setting high-speed on-chip oscillator Modification of description in 5.6.3 Example of setting XT1 oscillation clock Modification of description in Figure 5-15 Modification of caution in Table 5-3 (1/5)	CHAPTER 5 CLOCK GENERATOR

(9/38)

Edition	Description	Chapter
Rev.3.00	Modification of caution and note in Table 5-3 (2/5)	CHAPTER 5 CLOCK GENERATOR
	Modification of description in Table 5-3 (3/5)	
	Modification of description and caution in Table 5-3 (4/5)	
	Modification of description in Table 5-3 (5/5)	
	Modification of description in Table 5-4	
	Modification of Figure 5-16	
	Modification of description in (1) X1 oscillation: (1/2) (2/2)	
	Modification of description in (2) XT1 oscillation: Crystal resonator	
Rev.3.00	Modification of description of timer array unit	CHAPTER 6 TIMER ARRAY UNIT
	Modification of figure in (1) One-shot pulse output in 6.1.2 Simultaneous channel operation function	
	Modification of description in Table 6-2	
	Modification of description in Figure 6-1	
	Modification of description in Figures 6-2 and 6-3	
	Modification of description in Figures 6-4 and 6-5	
	Modification of caution 1 in 6.3.1 Peripheral enable register 0 (PER0)	
	Modification of description in 6.3.2 Timer clock select register m (TPSm)	
	Modification of description and caution 2 in Figure 6-10 (1/2)	
	Modification of description in Figure 6-10 (2/2)	
	Modification of description in 6.3.7 Timer channel stop register m (TTm)	
	Modification of description in Figure 6-15	
	Modification of description in Figure 6-17	
	Modification of description in 6.3.14 Noise filter enable registers 1, 2 (NFEN1, NFEN2)	
	Modification of description in 6.3.15 Register controlling port functions of pins to be used for timer I/O	
	Modification of remark in (2) Operation of event counter mode	
	Modification of description and remark in Figure 6-27	
	Modification of description in 6.7 Timer Input (TImn) Control	
	Modification of description in Figure 6-43	
	Modification of description in Figure 6-44	
	Modification of description in Figure 6-45	
	Modification of description in Figure 6-47	
	Modification of description in Figure 6-48	
	Modification of description in Figure 6-51	
	Modification of description in Figure 6-52	
	Modification of description in 6.8.4 Operation as input pulse interval measurement and in Figure 6-53	
	Modification of description in Figure 6-56	
	Modification of description in Figure 6-57	
	Modification of description in Figure 6-60	
	Modification of description in Figure 6-61	
	Modification of description in Figure 6-63	
	Modification of description in Figure 6-64	

(10/38)

Edition	Description	Chapter
Rev.3.00	Modification of description in Figure 6-65	CHAPTER 6 TIMER ARRAY UNIT
	Modification of description in Figure 6-67	
	Modification of description in Figure 6-69 (1/2)	
	Modification of description in Figure 6-69 (2/2)	
	Modification of description in Figure 6-72	
	Modification of description and note in Figure 6-73	
	Modification of description in Figure 6-77	
	Modification of description in Figure 6-78	
	Modification of description in 6.10.1 Cautions When Using Timer Output	
	Modification of description in 7.1 Functions of Real-time Clock	
Modification of description in Figure 7-1		
Modification of description in 7.3 Registers Controlling Real-time Clock		
Modification of cautions 1 and 2 in Figure 7-2		
Modification of description in 7.3.2 Subsystem clock supply mode control register (OSMC)		
Modification of note and caution 2 in Figure 7-4		
Modification of description in Figure 7-5 (1/2)		
Modification of description and remark 2 in Figure 7-5 (2/2)		
Modification of description and remark in 7.3.5 Second count register (SEC)		
Modification of description in 7.3.6 Minute count register (MIN)		
Modification of description in 7.3.7 Hour count register (HOUR)		
Modification of description in 7.3.8 Day count register (DAY)		
Modification of description in 7.3.9 Week count register (WEEK)		
Modification of description in 7.3.10 Month count register (MONTH)		
Modification of description in 7.3.11 Year count register (YEAR)		
Modification of description in 7.3.12 Watch error correction register (SUBCUD)		
Modification of description in 7.3.16 Port mode register 3 (PM3)		
Modification of description in 7.3.17 Port register 3 (P3)		
Modification of note 1 in 7.4.1 Starting operation of real-time clock		
Modification of description in 7.4.2 Shifting to HALT/STOP mode after starting operation		
Modification of cautions 1 and 2 in Figure 7-24		
Modification of description in 7.4.6 Example of watch error correction of real-time clock		
Modification of description in Figure 7-25	CHAPTER 8 12-BIT INTERVAL TIMER	
Modification of description in Table 8-1		
Modification of description and caution in Figure 8-1		
Modification of description in 8.3 Registers Controlling 12-bit Interval Timer		
Modification of cautions 1 and 2 in 8.3.1 Peripheral enable register 0 (PER0)		
Modification of description in 8.3.2 Subsystem clock supply mode control register (OSMC)		
Modification of description in 8.4.1 12-bit interval timer operation timing		
Modification of description in 8.4.2 Start of count operation and re-enter to HALT/STOP mode after returned from HALT/STOP mode		

(11/38)

Edition	Description	Chapter
Rev.3.00	Modification of description and caution in 9.1 Functions of Clock Output/Buzzer Output Controller	CHAPTER 9 CLOCK OUTPUT/BUZZER OUTPUT CONTROLLER
	Modification of note in Figure 9-1	
	Modification of description in 9.3 Registers Controlling Clock Output/Buzzer Output Controller	
	Modification of note and cautions 2 and 3 in Figure 9-2	
	Modification of description in 9.3.2 Registers controlling port functions of pins to be used for clock or buzzer output	
	Modification of description in 9.4.1 Operation as output pin	
	Modification of description in Figure 9-3	
	Modification of description in 9.5 Cautions of clock output/buzzer output controller	
	Modification of description in 10.1 Functions of Watchdog Timer	CHAPTER 10 WATCHDOG TIMER
	Modification of description in Table 10-1	
	Modification of description in Figure 10-1	
	Modification of caution 2 in 10.4.1 Controlling operation of watchdog timer	
	Modification of description in Table 10-3	
	Modification of remark in 10.4.3 Setting window open period of watchdog timer	
	Modification of description in 10.4.4 Setting watchdog timer interval interrupt	CHAPTER 11 A/D CONVERTER
	Modification of description in 11.1 Function of A/D Converter	
	Addition of description in Figure 11-1	
	Modification of description in 11.2 Configuration of A/D Converter	
	Modification of description in title (Registers Controlling A/D Converter) of 11.3	
	Modification of caution 1 in Figure 11-2	
	Modification of description of ADCS bit in Figure 11-3	
	Modification of Figure 11-4 and caution 4	
	Modification of Table 11-3, note, and caution 1	
	Modification of Table 11-3, note 4, and caution 1	
	Modification of Table 11-3, note 2, and caution 1	
	Modification of Table 11-3, note 5, and caution 1	
	Modification of Figure 11-5	
	Modification of caution 2 in Figure 11-6	
	Modification of description in 11.3.4 A/D converter mode register 2 (ADM2)	
	Modification of description of ADREFP1, ADREFP0, ADRCK, and AWC bits in Figure 11-7	
	Modification of Figure 11-8	
	Modification of description in 11.3.5 10-bit A/D conversion result register (ADCR)	
	Modification of cautions 8 and 9 in Figure 11-11	
	Modification of cautions 2 and 3 in Figure 11-13	
Modification of description in 11.3.10 A/D test register (ADTES)		
Modification of description of ADTES1 and ADTES0 bits in Figure 11-14. Format of A/D Test Register (ADTES)		
Modification of Figure 11-15		
Modification of Figure 11-22		

(12/38)

Edition	Description	Chapter	
Rev.3.00	Modification of Figure 11-23	CHAPTER 11 A/D CONVERTER	
	Modification of Figure 11-24		
	Modification of Figure 11-25		
	Modification of Figure 11-26		
	Modification of Figure 11-27		
	Modification of Figure 11-28		
	Modification of Figure 11-29		
	Modification of Figure 11-30		
	Modification of Figure 11-31		
	Modification of Figure 11-32		
	Modification of Figure 11-33 and caution		
	Modification of description in 11.8 SNOOZE Mode Function		
	Modification of Figure 11-37		
	Modification of Figures 11-40 and 11-41		
	Modification of description in 11.10 (4) Noise countermeasures		
	Modification of Figure 11-44		CHAPTER 12 SERIAL ARRAY UNIT
	Modification of description and note in 12.1.1 3-wire serial I/O		
	Modification of serial data output in Table 12-1		
	Modification of Figure 12-1		
	Modification of Figure 12-2		
	Modification of description in 12.2.2 Lower 8/9 bits of the serial data register mn (SDRmn)		
	Modification of note 2 in Figure 12-4		
	Modification of caution 1 in 12.3.1 Peripheral enable register 0 (PER0)		
	Modification of note 1 in Figure 12-6		
	Modification of note 1 in Figure 12-7		
	Modification of note 1 in Figure 12-8		
	Modification of description and note 1 in Figure 12-8		
	Modification of title and description in 12.3.5 Serial data register mn (SDRmn)		
	Modification of Figure 12-9 and caution 2		
	Modification of note 1 in Figure 12-10		
	Modification of note 1 in Figure 12-11		
	Modification of note 1 in Figure 12-12		
	Modification of note 1 and caution in Figure 12-13		
	Modification of note in Figure 12-14		
	Modification of note in Figure 12-15		
	Modification of notes 1 and 2 in Figure 12-16		
	Modification of note in Figure 12-17		
	Modification of Figure 12-18		
Modification of caution in 12.3.14 Serial standby control register m (SSCm)			
Modification of format and note in Figure 12-19			
Modification of Figure 12-20			
Modification of description in 12.3.16 Noise filter enable register 0 (NFEN0)			

(13/38)

Edition	Description	Chapter
Rev.3.00	Modification of description in 12.5 Operation of 3-Wire Serial I/O	CHAPTER 12 SERIAL ARRAY UNIT
	Modification of transfer rate and note in 12.5.1 Master transmission	
	Modification of Figure 12-28	
	Modification of Figure 12-29	
	Modification of Figure 12-30	
	Modification of Figure 12-31	
	Modification of Figure 12-32	
	Modification of description, transfer rate, clock phase, and note in 12.5.2 Master reception	
	Modification of Figure 12-35	
	Modification of Figure 12-36	
	Modification of Figure 12-37	
	Modification of Figure 12-39	
	Modification of Figure 12-40	
	Modification of description, transfer rate and note in 12.5.3 Master transmission/reception	
	Modification of Figure 12-43	
	Modification of Figure 12-45	
	Modification of Figure 12-47	
	Modification of Figure 12-48	
	Modification of description and notes 1 and 2 in 12.5.4 Slave transmission	
	Modification of Figure 12-51	
	Modification of Figure 12-52	
	Modification of Figure 12-53	
	Modification of Figure 12-54	
	Modification of Figure 12-55	
	Modification of Figure 12-56	
	Modification of description and notes 1 and 2 in 12.5.5 Slave reception	
	Modification of Figure 12-59	
	Modification of Figure 12-61	
	Modification of description and notes 1 and 2 in 12.5.6 Slave transmission/reception	
	Modification of Figure 12-65	
	Modification of Figure 12-67	
	Modification of Figure 12-69	
	Modification of Figure 12-70	
	Modification of Figure 12-71 and caution 2	
Modification of Figure 12-72		
Modification of Figure 12-73 and caution 2		
Modification of Figure 12-74		
Modification of description in 12.6 Operation of UART (UART0 to UART3) Communication		
Modification of description and note 2 in 12.6.1 UART transmission		
Modification of note 1 in Figure 12-76		
Modification of Figures 12-77 and 12-78		
Modification of Figure 12-79		

(14/38)

Edition	Description	Chapter	
Rev.3.00	Modification of Figure 12-80	CHAPTER 12 SERIAL ARRAY UNIT	
	Modification of Figure 12-81		
	Modification of Figure 12-82		
	Modification of Figure 12-83		
	Modification of description and note 2 in 12.6.2 UART reception		
	Modification of note 1 in Figure 12-84		
	Modification of Figure 12-86		
	Modification of Figure 12-88		
	Modification of Figure 12-89		
	Modification of description in 12.6.3 SNOOZE mode function		
	Modification of Table 12-3		
	Modification of description in (1) SNOOZE mode operation in 12.6.3 SNOOZE mode function		
	Modification of description in (2) SNOOZE mode operation in 12.6.3 SNOOZE mode function		
	Modification of Figure 12-92 and remark 1		
	Modification of Figure 12-94		
	Modification of caution and remark 1 in (1) Baud rate calculation expression in 12.6.4 Calculating baud rate		
	Modification of note in 12.7.1 LIN transmission		
	Modification of Figure 12-98 and notes 1 and 3		
	Modification of note in 12.7.2 LIN reception		
	Modification of Figure 12-102		
	Modification of notes 1 and 2 in 12.8.1 Address field transmission		
	Modification of note 2 in Figure 12-104		
	Modification of notes 1 and 2 in 12.8.2 Data transmission		
	Modification of notes 1 and 3 in Figure 12-108		
	Modification of notes 1 and 2 in 12.8.3 Data reception		
	Modification of note 1 in Figure 12-111		
	Modification of description in Figures 12-116 and 12-117		
	Modification of note 2 in Figure 13-6		CHAPTER 13 SERIAL INTERFACE IICA
	Modification of note in Figure 13-6		
	Modification of cautions 1 and 2 in Figure 13-9		
	Modification of remark 1 in Figure 13-11		
	Modification of Figure 13-24		
	Modification of Figure 13-28		
Modification of Figure 13-29			
Modification of Figure 13-30	CHAPTER 14 MULTIPLIER AND DIVIDER/MULTIPLY-ACCUMULATOR		
Modification of Figure 14-1 and addition of remark			
Modification of description in 14.3.1 Multiplication/division control register (MDUC)			
Modification of description in Figure 14-5. Format of Multiplication/Division Control Register (MDUC)			
Modification of description in 14.4.1 Multiplication (unsigned) operation			
Modification of description in 14.4.2 Multiplication (signed) operation			
Modification of description in 14.4.3 Multiply-accumulation (unsigned) operation			

(15/38)

Edition	Description	Chapter
Rev.3.00	Modification of description in 14.4.4 Multiply-accumulation (signed) operation	CHAPTER 14
	Modification of Figure 14-9	MULTIPLIER AND
	Modification of description in 14.4.5 Division operation	DIVIDER/MULTIPLY-
		ACCUMULATOR
	Modification of description in 15.1 Functions of DMA Controller	CHAPTER 15 DMA
	Modification of Figure 15-9	CONTROLLER
	Modification of description in (4) DMA pending instruction in 15.6	
	Modification of description in (6) Operation if instructions for accessing the data flash area in 15.6	
	Modification of description and note 3 in Table 16-1	CHAPTER 16
	Modification of notes 3 and 6 in Table 16-2	INTERRUPT
	Modification of note 3 in Table 16-2	FUNCTIONS
	Modification of note in Table 16-2	
	Modification of format of Figure 16-2 and caution 1	
	Modification of description in 16.3.2 Interrupt mask flag registers (MK0L, MK0H, MK1L, MK1H, MK2L, MK2H, MK3L)	
	Modification of format of Figure 16-3 and caution	
	Modification of format of Figure 16-4 and caution	
	Modification of format of Figure 16-5	
	Modification of description in 16.3.5 Program status word (PSW)	
	Modification of Figure 16-9	
	Modification of Table 16-5 and remark 3	
	Modification of description in 16.4.4 Interrupt request hold	
	Modification of description in 17.1 Functions of Key Interrupt	CHAPTER 17 KEY
	Modification of description in Tables 17-1 and 17-2	INTERRUPT
	Modification of description in 17.3 Register Controlling Key Interrupt	FUNCTION
	Modification of caution 2 in Figure 17-2	
	Addition of 17.3.2 Port mode register 7 (PM7)	
	Modification of description in 18.2 Registers controlling standby function	CHAPTER 18
	Modification of caution in 18.3.1 HALT mode	STANDBY FUNCTION
	Modification of Figures 18-2 (1) and (2)	
	Modification of caution in 18.3.2 STOP mode	
	Modification of Figure 18-3 (1) and remark 1	
	Modification of Figure 18-3 (2) and note 2	
	Modification of notes 1 and 2, caution, and remarks 1 and 2 in Figure 18-3 (3)	
	Modification of Figures 18-4 (1) and (2)	
	Modification of description of (1) in 18.3.3 SNOOZE mode	
	Modification of description in Table 18-3	
	Modification of description of (2) and (3) in 18.3.3 SNOOZE mode	
	Modification of description, caution 3, and remark in the beginning of the chapter	CHAPTER 19 RESET
	Modification of Figure 19-2	FUNCTION
	Modification of note 3 in Figure 19-3	
	Modification of description in Table 19-1 and addition of note	
Modification of remark in Table 19-2		

(16/38)

Edition	Description	Chapter
Rev.3.00	Modification of format of Figure 19-4	CHAPTER 19 RESET FUNCTION
	Modification of description in Table 19-3	
	Modification of Figure 19-5	
Rev.3.00	Modification of description, caution, and remark 2 in 20.1 Functions of Power-on-reset Circuit	CHAPTER 20 POWER-ON-RESET CIRCUIT
	Modification of description, notes 2 to 5, and caution in Figure 20-2 (1)	
	Modification of description and notes 1 and 2 in Figure 20-2 (2)	
	Modification of description, notes 1 and 2, and remark 2 in Figure 20-2 (3)	
	Modification of description in 21.1 Functions of Voltage Detector	
	Modification of description in Figure 21-1	
	Modification of description and note 3 in Figure 21-2	
	Modification of note 2 and cautions 1 and 2 in Figure 21-3	
	Modification of description in Figure 21-4 (1/2)	
	Modification of description in Figure 21-4 (2/2) and caution 2	
	Modification of description in 21.4.1 When used as reset mode	
	Modification of description in Figure 21-5	
	Modification of description in 21.4.2 When used as interrupt mode	
	Modification of description and note 2 in Figure 21-6	
	Modification of description in 21.4.3 When used as interrupt & reset mode	
	Modification of description in Figure 21-7 (1/2)	
	Modification of description in Figure 21-7 (2/2)	
	Modification of description in Figure 21-8	
	Modification of description in Figure 21-9	
	Rev.3.00	
Modification of description in Figure 21-10		
Modification of description of (3) and (4) in 21.5 Cautions for Voltage Detector		
Rev.3.00	Modification of description of (6) and (7) in 22.1 Overview of Safety Functions and remark	CHAPTER 22 SAFETY FUNCTIONS
	Modification of description in Figure 22-3	
	Modification of caution and remarks 2 and 4 in Figure 22-7	
	Modification of description in Figure 22-8	
	Modification of description in Figure 22-9	
	Modification of description in Figure 22-11	
	Modification of description in 22.3.7 Frequency detection function	
	Modification of description in 22.3.7.1 Timer input select register 0 (TIS0)	
	Modification of description in 22.3.8 A/D test function	
	Modification of description in Figure 22-15	
	Modification of description in 22.3.8.1 A/D test register (ADTES)	
	Modification of cautions 2 to 4 and 9 in Figure 22-17	
Rev.3.00	Modification of description in 24.1 Functions of Option Bytes	CHAPTER 24 OPTION BYTE
	Modification of description in 24.1.1 User option byte (000C0H to 000C2H/010C0H to 010C2H) (1), (2), and (3)	
	Modification of description in Figure 24-2 (1/2)	
	Modification of description, caution 2, and remark 3 in Figure 24-2 (2/2)	

(17/38)

Edition	Description	Chapter
Rev.3.00	Modification of description and caution 2 in Figure 24-3	CHAPTER 24 OPTION BYTE
	Modification of description in 24.4 Setting of Option Byte	
	Modification of description in the beginning of the chapter	CHAPTER 25 FLASH MEMORY
	Modification of Table 25-1	
	Modification of Figure 25-1	
	Modification of note 2 in Table 25-2	
	Addition of note in Figure 25-3	
	Modification of note 1 in Figure 25-4	
	Modification of description in Table 25-3	
	Modification of remark in 25.3 Connection of Pins on Board	
	Modification of description and remark 1 in 25.3.1 P40/TOOL0 pin	
	Modification of description in 25.3.4 REGC pin	
	Modification of description in 25.4.2 Flash memory programming mode and Figure 25-7	
	Addition of Table 25-5. Programming Modes and Voltages at Which Data Can Be Written, Erased, or Verified	
	Modification of description in 25.4.4 Communication commands	
	Modification of description in Table 25-7	
	Modification of description in Table 25-8	
	Addition of note in Figure 25-3	
	Modification of note 1 in Figure 25-4	
	Modification of description in 25.5 Processing Time for Each Command When PG-FP5 Is in Use (Reference Value)	
	Modification of description in 25.6 Self-Programming	
	Modification of description in 25.7 Security Settings	
Modification of caution in Table 25-13		
Modification of caution 1 in 25.8.1 Data flash overview		
Modification of caution 2 in 25.8.3 Procedure for accessing data flash memory		
Modification of description and remark in Figure 26-1	CHAPTER 26 ON-CHIP DEBUG FUNCTION	
Modification of description in 26.3 Securing of User Resources	CHAPTER 28 INSTRUCTION SET	
Modification of overview of instruction set in the beginning of the chapter		
Modification of note 3 in Table 28-5 (1/17)		
Modification of note 2 in Table 28-5 (2/17)		
Modification of note 2 in Table 28-5 (3/17)		
Modification of note 2 in Table 28-5 (4/17)		
Modification of note 2 in Table 28-5 (5/17)		
Modification of note 2 in Table 28-5 (6/17)		
Modification of note 2 in Table 28-5 (7/17)		
Modification of note 2 in Table 28-5 (8/17)		
Modification of note 2 in Table 28-5 (9/17)		
Modification of note 2 in Table 28-5 (10/17)		
Modification of note 2 in Table 28-5 (11/17)		
Modification of note 2 in Table 28-5 (12/17)		
Modification of note 2 in Table 28-5 (13/17)		

(18/38)

Edition	Description	Chapter	
Rev.3.00	Modification of note 2 in Table 28-5 (14/17)	CHAPTER 28 INSTRUCTION SET	
	Modification of note 2 in Table 28-5 (15/17)		
	Modification of note 2 in Table 28-5 (16/17)		
	Modification of note 2 in Table 28-5 (17/17)		
Rev.3.00	Modification of description in table of Absolute Maximum Ratings ($T_A = 25^\circ\text{C}$)	CHAPTER 29 ELECTRICAL SPECIFICATIONS (A, D: $T_A = -40$ to $+85^\circ\text{C}$)	
	Modification of table, note, caution, and remark in 29.2.1 X1, XT1 oscillator characteristics		
	Modification of table in 29.2.2 On-chip oscillator characteristics		
	Modification of note 3 of table (1/5) in 29.3.1 Pin characteristics		
	Modification of note 3 of table (2/5) in 29.3.1 Pin characteristics		
	Modification of table in (1) Flash ROM: 16 to 64 KB of 20- to 64-pin products		
	Modification of notes 1 and 4 in (1) Flash ROM: 16 to 64 KB of 20- to 64-pin products		
	Modification of table in (1) Flash ROM: 16 to 64 KB of 20- to 64-pin products		
	Modification of notes 1, 5, and 6 in (1) Flash ROM: 16 to 64 KB of 20- to 64-pin products		
	Modification of notes 1 and 4 in (2) Flash ROM: 96 to 256 KB of 30- to 100-pin products		
	Modification of notes 1, 5, and 6 in (2) Flash ROM: 96 to 256 KB of 30- to 100-pin products		
	Modification of notes 1 and 4 in (3) Flash ROM: 384 to 512 KB of 44- to 100-pin products		
	Modification of notes 1, 5, and 6 in (3) Flash ROM: 384 to 512 KB of 44- to 100-pin products		
	Modification of (4) Peripheral Functions (Common to all products)		
	Modification of table in 29.4 AC Characteristics		
	Addition of Minimum Instruction Execution Time during Main System Clock Operation		CHAPTER 29 ELECTRICAL SPECIFICATIONS (A, D: $T_A = -40$ to $+85^\circ\text{C}$)
	Modification of figures of AC Timing Test Points and External System Clock Timing		
	Modification of figure of AC Timing Test Points		
	Modification of description and note 3 in (1) During communication at same potential (UART mode)		
	Modification of description in (2) During communication at same potential (CSI mode)		
Modification of description in (3) During communication at same potential (CSI mode)			
Modification of description in (4) During communication at same potential (CSI mode) (1/2)			
Modification of description in (4) During communication at same potential (CSI mode) (2/2)			
Modification of table in (5) During communication at same potential (simplified I2C mode) (1/2)			
Modification of table and caution in (5) During communication at same potential (simplified I2C mode) (2/2)			
Modification of table and notes 1 and 4 in (6) Communication at different potential (1.8 V, 2.5 V, 3 V) (UART mode) (1/2)			
Modification of table and notes 2 to 7 in (6) Communication at different potential (1.8 V, 2.5 V, 3 V) (UART mode) (2/2)			
Modification of remarks 1 to 4 in (6) Communication at different potential (1.8 V, 2.5 V, 3 V) (UART mode) (2/2)			
Modification of table in (7) Communication at different potential (2.5 V, 3 V) (CSI mode) (1/2)			
Modification of table and caution in (7) Communication at different potential (2.5 V, 3 V) (CSI mode) (2/2)			
Modification of table, note 1, and caution in (8) Communication at different potential (1.8 V, 2.5 V, 3 V) (CSI mode) (3/3)			

(19/38)

Edition	Description	Chapter
Rev.3.00	Modification of remarks 3 and 4 in (8) Communication at different potential (1.8 V, 2.5 V, 3 V) (CSI mode) (3/3)	CHAPTER 29 ELECTRICAL SPECIFICATIONS (A, D: T _A = -40 to +85°C)
	Modification of table in (9) Communication at different potential (1.8 V, 2.5 V, 3 V) (CSI mode) (1/2)	
	Modification of table and caution in (9) Communication at different potential (1.8 V, 2.5 V, 3 V) (CSI mode) (2/2)	
	Modification of table in (10) Communication at different potential (1.8 V, 2.5 V, 3 V) (simplified I ² C mode) (1/2)	
	Modification of table, note 1, and caution in (10) Communication at different potential (1.8 V, 2.5 V, 3 V) (simplified I ² C mode) (2/2)	
	Addition of (1) I ² C standard mode	
	Addition of (2) I ² C fast mode	
	Addition of (3) I ² C fast mode plus	
	Modification of IICA serial transfer timing	
	Addition of table in 29.6.1 A/D converter characteristics	
	Modification of description in 29.6.1 (1)	
	Modification of notes 3 to 5 in 29.6.1 (1)	
	Modification of description and notes 2, 4, and 5 in 29.6.1 (2)	
	Modification of description and notes 3 and 4 in 29.6.1 (3)	
	Modification of description and notes 3 and 4 in 29.6.1 (4)	
	Modification of table in 29.6.2 Temperature sensor/internal reference voltage characteristics	
	Modification of table and note in 29.6.3 POR circuit characteristics	
	Modification of table in 29.6.4 LVD circuit characteristics	
	Modification of table of LVD Detection Voltage of Interrupt & Reset Mode	
	Renamed to 29.6.5 Power supply voltage rising slope characteristics	
	Modification of table, figure, and remark in 29.10 Timing Specs for Switching Flash Memory Programming Modes	
	Modification of caution 1 and description	CHAPTER 30 ELECTRICAL SPECIFICATIONS (G: T _A = -40 to +105°C)
	Modification of table and remark 3 in Absolute Maximum Ratings (T _A = 25°C)	
	Modification of table, note, caution, and remark in 30.2.1 X1, XT1 oscillator characteristics	
	Modification of table in 30.2.2 On-chip oscillator characteristics	
	Modification of note 3 in 30.3.1 Pin characteristics (1/5)	
	Modification of note 3 in 30.3.1 Pin characteristics (2/5)	
	Modification of notes 1 and 4 in (1) Flash ROM: 16 to 64 KB of 20- to 64-pin products (1/2)	
	Modification of notes 1, 5, and 6 in (1) Flash ROM: 16 to 64 KB of 20- to 64-pin products (2/2)	
	Modification of notes 1 and 4 in (2) Flash ROM: 96 to 256 KB of 30- to 100-pin products (1/2)	
	Modification of notes 1, 5, and 6 in (2) Flash ROM: 96 to 256 KB of 30- to 100-pin products (2/2)	
	Modification of (3) Peripheral Functions (Common to all products)	
	Modification of table in 30.4 AC Characteristics	
	Addition of Minimum Instruction Execution Time during Main System Clock Operation	
	Modification of figure of AC Timing Test Points	
	Modification of figure of External System Clock Timing	
	Modification of figure of AC Timing Test Points	

(20/38)

Edition	Description	Chapter
Rev.3.00	Modification of description, note 1, and caution in (1) During communication at same potential (UART mode)	CHAPTER 30 ELECTRICAL SPECIFICATIONS (G: T _A = -40 to +105°C)
	Modification of description in (2) During communication at same potential (CSI mode)	
	Modification of description in (3) During communication at same potential (CSI mode)	
	Modification of table, note 1, and caution in (4) During communication at same potential (simplified I ² C mode)	
	Modification of table, note 1, and caution in (5) Communication at different potential (1.8 V, 2.5 V, 3 V) (UART mode) (1/2)	
	Modification of table, notes 2 to 6, caution, and remarks 1 to 4 in (5) Communication at different potential (1.8 V, 2.5 V, 3 V) (UART mode) (2/2)	
	Modification of table in (6) Communication at different potential (1.8 V, 2.5 V, 3 V) (CSI mode) (1/3)	
	Modification of table and caution in (6) Communication at different potential (1.8 V, 2.5 V, 3 V) (CSI mode) (2/3)	
	Modification of table, caution, and remarks 3 and 4 in (6) Communication at different potential (1.8 V, 2.5 V, 3 V) (CSI mode) (3/3)	
	Modification of table and caution in (7) Communication at different potential (1.8 V, 2.5 V, 3 V) (CSI mode)	
	Modification of table in (8) Communication at different potential (1.8 V, 2.5 V, 3 V) (simplified I ² C mode) (1/2)	
	Modification of table, note 1, and caution in (8) Communication at different potential (1.8 V, 2.5 V, 3 V) (simplified I ² C mode) (2/2)	
	Modification of table in 30.5.2 Serial interface IICA	
	Modification of IICA serial transfer timing	
	Addition of table in 30.6.1 A/D converter characteristics	
	Modification of table and notes 3 and 4 in 30.6.1 (1)	
	Modification of description in 30.6.1 (2)	
	Modification of description and note 3 in 30.6.1 (3)	
	Modification of description and notes 3 and 4 in 30.6.1 (4)	
	Modification of table and note in 30.6.3 POR circuit characteristics	
	Modification of table of LVD Detection Voltage of Interrupt & Reset Mode	
	Modification from Supply Voltage Rise Time to 30.6.5 Power supply voltage rising slope characteristics	
	Modification of 30.9 Dedicated Flash Memory Programmer Communication (UART)	
Modification of table, figure, and remark in 30.10 Timing Specs for Switching Flash Memory Programming Modes		
Rev.2.10	Deletion of overline in SCK and SCK**	Throughout
	Renamed f _{EXT} to f _{EXS}	
	Modification of 1.1 Features	CHAPTER 1 OUTLINE
	Modification from 1.2 Ordering Information to 1.2 List of Part Numbers	
	Modification of 1.2 List of Part Numbers	
	Modification of description of INTP0 to INTP11 in 1.4 Pin Identification	
	Addition and modification of description and note in 1.6 Outline of Functions	
Modification of error in Table 2-2. Relationships Between P40/TOOL0 and Operation Mode After Reset Release	CHAPTER 2 PIN FUNCTIONS	

(21/38)

Edition	Description	Chapter
Rev.2.10	Modification of description in 3.1 Memory Space	CHAPTER 3 CPU ARCHITECTURE
	Modification of caution in Figures 3-1 to 3-10	
	Modification of description in 3.1.1 Internal program memory space	
	Deletion of note and cautions 2 and 3 and addition of caution 2 in Figure 3-11. Format of Processor Mode Control Register (PMC)	
	Modification of description and cautions 1 and 2 in 3.1.3 Internal data memory space	
	Modification of description in 3.1.6 Data memory addressing	
	Modification of caution in Figures 3-12 to 3-21	
	Modification of 3.2.1 Control registers, 3.2.2 General-purpose registers, and 3.2.3 ES and CS registers	
	Modification of description in 3.2.4 Special function registers (SFRs)	
	Modification of note in 3.2.5 Extended special function registers (2nd SFRs: 2nd Special Function Registers)	
	Modification of After Reset of HIOTRM register and note in Table 3-6. Extended SFR (2nd SFR) List (2/8)	
	Modification of Figures 3-28 to 3-30 and 3-32 to 3-49	
	Modification of [Operand format] in 3.4.1 Implied addressing	
	Modification of [Operand format] in 3.4.3 Direct addressing	
	Modification of [Operand format] in 3.4.5 SFR addressing	
	Modification of [Function] in 3.4.7 Based addressing	
	Modification from [Operand format] to [Description format], modification of [Function] and [Description format], and addition of description in 3.4.9 Stack addressing	
	Modification of error in Table 4-20 (2/3)	CHAPTER 4 PORT FUNCTIONS
	Modification of caution in Figure 5-2. Format of Clock Operation Mode Control Register (CMC)	CHAPTER 5 CLOCK GENERATOR
	Deletion of cautions 1 to 4 and addition of cautions 1 to 3 in 5.3.8 High-speed on-chip oscillator frequency select register (HOCODIV)	
	Modification of description in 5.4.2 XT1 oscillator	
	Modification of caution in Figure 5-12. Example of External Circuit of XT1 Oscillator	
	Modification of Figure 5-14. Clock Generator Operation When Power Supply Voltage Is Turned On and note 3	
	Modification of description of [Option byte setting] in 5.6.1 Example of setting high-speed on-chip oscillator	
	Modification of description of [Register settings] in 5.6.2 Example of setting X1 oscillation clock	
	Modification of caution 1 in 5.7 Resonator and Oscillator Constants	
	Modification of date of data in 5.7 (1) X1 oscillation	
	Addition of data from RIVER ELETEC CORPORATION in 5.7 (1) X1 oscillation	
	Modification of date of data in 5.7 (2) XT1 oscillation: Crystal resonator	
	Modification of data from Seiko Instruments Inc. and Nihon Dempa Kogyo Co., Ltd., and KYOCERA KINSEKI Corporation and addition of data from RIVER ELETEC CORPORATION in 5.7 (2) XT1 oscillation: Crystal resonator	

(22/38)

Edition	Description	Chapter
Rev.2.10	Modification of description in 6.2.2 Timer data register mn (TDRmn)	CHAPTER 6 TIMER ARRAY UNIT
	Modification of Setting of starting counting and interrupt in Figure 6-12. Format of Timer Mode Register mn (TMRmn) (4/4)	
	Addition of description to Figure 6-29. Operation Timing (In Capture Mode: Input Pulse Interval Measurement)	
	Modification from Figure 7-23. Operation when ~ to Figure 7-23. Correction Operation when ~.	CHAPTER 7 REAL-TIME CLOCK
	Modification from interrupt signal to interrupt request signal in Figure 8-1. Block Diagram of 12-bit Interval Timer	CHAPTER 8 INTERVAL TIMER
	Modification of 8.3 (1) Peripheral enable register 0 (PER0)	
	Modification of description in 8.3 (2) Operation speed mode control register (OSMC)	
	Modification of Figure 8-5. 12-bit Interval Timer Operation Timing ~	
	Modification of error in Figure 11-1. Block Diagram of A/D Converter	CHAPTER 11 A/D CONVERTER
	Modification of error in 11.2 (9) AV _{REFP} pin	
	Modification of caution 1 in 11.3.1 Peripheral enable register 0 (PER0)	
	Modification of cautions 1 and 3 and addition of caution 2 in 11.3.2 A/D converter mode register 0 (ADM0)	
	Modification of Table 11-1. Settings of ADCS and ADCE Bits	
	Modification of Table 11-3. A/D Conversion Time Selection (1/4) to (4/4)	
	Modification of caution 1 in 11.3.3 A/D converter mode register 1 (ADM1)	
	Modification of caution 1 in 11.3.4 A/D converter mode register 2 (ADM2)	
	Modification of caution in Figure 11-7. Format of A/D Converter Mode register 2 (ADM2) (2/2)	
	Modification of caution 5 in 11.3.7 Analog input channel specification register (ADS)	
	Modification of description in Figure 11-31. Example of Hardware Trigger Wait Mode (~)	
	Modification from 11.7.4 Setup when using temperature sensor (~) to 11.7.4 Setup when temperature sensor output/internal reference voltage output is selected (~)	
	Modification from Figure 11-35. Setup When Using Temperature Sensor to Figure 11-35. Setup when temperature sensor output/internal reference voltage output is selected	
	Modification of description in Figure 12-85. (c) Serial communication operation setting register mn (SCRmn)	
	Modification of value in 12.6.4 (2) Baud rate error during transmission	
	Modification of operation mode selection in Figure 14-5. Format of Multiplication/Division Control register (MDUC)	CHAPTER 14 MULTIPLIER AND DIVIDER/MULTIPLY-ACCUMULATOR
	Modification of value in Figure 14-9. Timing diagram of Multiply-Accumulation (signed) Operation (~)	
	Modification of caution 1 in 17.3 (1) Key return mode register (KRM)	CHAPTER 17 KEY INTERRUPT FUNCTION
	Modification of caution 1 in 18.1 (3) SNOOZE mode	CHAPTER 18 STANDBY FUNCTION
	Modification of description of timer array unit in Table 18-1 (2/2)	
	Modification of description of clock output/buzzer output in Table 18-1 (2/2)	
	Modification of description of serial array unit (SAU) in Table 18-1 (2/2)	
	Modification of description of multiplier and divider/multiply-accumulator in Table 18-1 (2/2)	
	Modification of description and note in Figure 18-4. HALT Mode Release by Reset	
	Modification of caution 1 in 18.3.2 (1) STOP mode setting and operating statuses	
Modification of description of clock output/buzzer output in Table 18-2		
Modification of caution 1 in 18.3.2 (1) STOP mode setting and operating statuses		

(23/38)

Edition	Description	Chapter
Rev.2.10	Modification of description and note in Figure 18-6. STOP Mode Release by Reset	CHAPTER 18
	Modification of description in 18.3.3 (1) SNOOZE mode setting and operating statuses	STANDBY FUNCTION
	Modification of description of clock output/buzzer output in Table 18-3	
	Modification of caution 3 in CHAPTER 19 RESET FUNCTION	CHAPTER 19 RESET FUNCTION
	Modification of description and addition of note in Figure 19-2	
	Modification of title and description in Figure 19-3	
	Deletion of Figure 19-4	
	Modification of port (latch) in Table 19-1	
	Modification of description of high-speed on-chip oscillator trimming register (HIOTRM) in Table 19-2. Hardware Statuses After Reset Acknowledgment (1/4)	
	Modification of note 2 in Table 19-2. Hardware Statuses After Reset Acknowledgment (1/4)	
	Modification of caution 2 in Figure 19-5. Format of Reset Control Flag Register (RESF)	
	Modification of Figure 20-2. Timing of Generation of Internal Reset Signal by Power-on-reset Circuit and Voltage Detector (1/3), Figure 20-2. Timing of Generation of Internal Reset Signal by Power-on-reset Circuit and Voltage Detector (2/3), and note	CHAPTER 20 POWER-ON-RESET CIRCUIT
	Addition of Figure 20-2. Timing of Generation of Internal Reset Signal by Power-on-reset Circuit and Voltage Detector (3/3)	
	Modification of caution in Figure 22-7. Format of RAM Parity Error Control Register (RPECTL)	CHAPTER 22 SAFETY FUNCTIONS
	Modification of description in 24.1 Functions of Option Bytes	CHAPTER 24 OPTION BYTE
	Modification of caution in Figure 24-1	
	Modification of caution in Figure 24-3. Format of Option Byte (000C2H/010C2H)	
	Modification of description and caution in 25.4.1 Data flash overview	CHAPTER 25 FLASH MEMORY
	Modification of error in Table 25-4. Relationship Between TOOL0 Pin and Operation Mode After Reset Release	
	Modification of caution 4 in 25.7 Flash Memory Programming by Self-Programming	
	Modification of error in Table 28-5. Operation List (14/17)	CHAPTER 28 INSTRUCTION SET
	Renamed to CHAPTER 29 ELECTRICAL SPECIFICATIONS (A, D: T _A = -40 to +85°C)	CHAPTER 29 ELECTRICAL SPECIFICATIONS (A, D: T _A = -40 to +85°C)
	Addition of description to CHAPTER 29 ELECTRICAL SPECIFICATIONS (A, D: T _A = -40 to +85°C)	
	Modification of note 8 in 29.3.2 (1) Flash ROM: 16 to 64 KB of 20- to 64-pin products	
	Modification of note 8 in 29.3.2 (2) Flash ROM: 96 to 256 KB of 30- to 100-pin products	
	Modification of note 8 in 29.3.2 (3) 128-pin products, and flash ROM: 384 to 512 KB of 44- to 100-pin products	
	Modification of notes 3 to 7 in 29.3.2 (4) Common to RL78/G13 all products	
	Deletion of note 2 in 29.6.1 A/D converter characteristics (1) to (3)	
	Renamed to 29.6.2 Temperature sensor/internal reference voltage characteristics	
	Modification of description in 29.6.2 Temperature sensor/internal reference voltage characteristics	
Modification of description in 29.6.4 LVD Detection Voltage of Interrupt & Reset Mode		
Modification of conditions in 29.8 Flash Memory Programming Characteristics		
Addition of note 3 to 29.8 Flash Memory Programming Characteristics		

(24/38)

Edition	Description	Chapter
Rev.2.10	Addition of products for industrial applications (T _A = -40 to +105°C)	CHAPTER 30 ELECTRICAL SPECIFICATIONS (G: T _A = -40 to +105°C)
	Addition of products for industrial applications (T _A = -40 to +105°C)	CHAPTER 31 PACKAGE DRAWINGS
Rev.2.01	Modification of formats of register names	Throughout
Rev.2.00	Renamed interval timer (unit) to 12-bit interval timer	Throughout
	Addition of pin name of the peripheral I/O redirection function	
	Renamed V _{LVI} , V _{LVIH} , V _{LVL} to V _{LVD} , V _{LVDH} , V _{LVDL} (LVD detection voltage)	
	Renamed interrupt source of RAM parity error (RAMTOP) to RPE	
	Renamed f _{EXS} to f _{EXT}	
	Addition of 1.1 Features	CHAPTER 1 OUTLINE
	Modification of 1.2 Ordering Information	
	Addition of Figure 1-1. Part Number, Memory Size, and Package of RL78/G13	
	Modification of 1.3.11 64-pin products	
	Addition and Modification of description in 1.6 Outline of Functions	
	Modification of 2.1 Port Function	CHAPTER 2 PIN FUNCTIONS
	Modification of description in 2.2 Functions other than port pins (Deletion of Description of Port Function)	
	Addition of remark to 2.3 Pin I/O Circuits and Recommended Connection of Unused Pins	
	Change of Table 2-3. Connection of Unused Pins (128-pin products) (2/4)	
	Addition of note 1 to Figures 3-1, 3-2, 3-5 to 3-7, 3-9	CHAPTER 3 CPU ARCHITECTURE
	Addition of caution to Figures 3-1 to 3-10	
	Modification of note in Figures 3-3, 3-4, 3-8, 3-10	
	Addition of remark to Table 3-1. Correspondence Between Address Values and Block Numbers in Flash Memory	
	Modification of description in 3.1.2 Mirror area	
	Modification of caution 2 in 3.1.3 Internal data memory space	
	Addition of note 1 to Figures 3-12, 3-13, 3-16 to 3-18, 3-20	
	Addition of caution to Figures 3-12 to 3-21	
	Addition of note 1 to Figures 3-14, 3-15, 3-19, 3-21	
	Modification of caution 3 in 3.2.1 (3) Stack pointer (SP)	
	Modification of caution 2 in 3.2.2 General-purpose registers	
	Modification of 4.1 Port Functions	CHAPTER 4 PORT FUNCTIONS
	Modification of block diagrams	
	Addition of description to 4.2.3 Port 2	
	Addition of description to 4.2.16 Port 15	
	Addition of caution to 4.3 Registers Controlling Port Function	
	Modification of Figure 4-66. Format of Port Register (128-pin products)	
	Modification of description and addition of caution to 4.3 (3) Pull-up resistor option registers (PUxx)	
	Addition of 4.3 (5) Port output mode registers (POMxx)	
	Addition of cautions 1 and 2 to Figure 4-70. Format of Port Mode Control Register	

(25/38)

Edition	Description	Chapter
Rev.2.00	Addition of caution 1 to Figure 4-71. Format of A/D Port Configuration Register (ADPC)	CHAPTER 4 PORT FUNCTIONS
	Modification of description in 4.3 (8) Peripheral I/O redirection register (PIOR)	
	Addition of remark to 4.3 (9) Global digital input disable register (GDIDIS)	
	Modification of description in 4.4.1 (2) Input mode and 4.4.3 (2) Input mode	
	Addition of remark to 4.4.4 (1) (a) Use as 1.8 V, 2.5 V, 3 V input port and (b) Use as 1.8 V, 2.5 V, 3 V output port	
	Addition of description to 4.4.4 (2) Setting procedure when using I/O pins of IIC00, IIC01, IIC10, IIC20, IIC30, and IIC31 functions	
	Addition of caution to 4.5 Settings of Port Mode Register, and Output Latch When Using Alternate Function	
	Modification of Table 4-22. Settings of Port Register When Using Alternate Function	
	Addition of 4.6.2 Notes on specifying the pin settings	
	Addition of 5.1 (1) <2> High-speed on-chip oscillator	
	Modification of Figure 5-1. Block Diagram of Clock Generator	
	Modification of caution 1 and addition of cautions 4 to 6 to Figure 5-2. Format of Clock Operation Mode Control Register (CMC)	
	Modification of caution 3 in Figure 5-9. Format of High-speed On-chip Oscillator Frequency Select Register (HOCODIV)	
	Modification of note 3 in Figure 5-14. Clock Generator Operation When Power Supply Voltage Is Turned On	
	Addition of description to 5.6.2 Example of setting X1 oscillation clock	
	Addition of description to Figure 5-15. CPU Clock Status Transition Diagram	
	Modification of Table 5-3. CPU Clock Transition and SFR Register Setting Examples	
	Modification and deletion of description in Table 5-4. Changing CPU Clock	
	Modification of remark 2 to 5.6.6 Time required for switchover of CPU clock and system clock	
	Addition of 5.7 Recommended Oscillator Constants	CHAPTER 6 TIMER ARRAY UNIT
	Modification of description in 6.1.1 (7) Delay counter	
	Modification of caution in 6.1.2 (3) Multiple PWM (Pulse Width Modulation) output	
	Modification of Figure 6-2. Internal Block Diagram of Channels of Timer Array Unit 0, 2, 4, 6	
	Addition of Figures 6-3 to 6-6	
	Modification of Table 6-3. Timer Count Register mn (TCRmn) Read Value in Various Operation Modes	
	Modification of caution 1 in Figure 6-10. Format of Peripheral Enable Register 0 (PER0)	
	Modification of note and remark 2 and addition of caution 2 to Figure 6-11. Format of Timer Clock Select register m (TPSm)	
	Modification of Figure 6-12. Format of Timer Mode Register mn (TMRmn)	
	Modification of description in Figure 6-16. Format of Timer Channel Stop register m (TTm)	
	Addition of caution to Figure 6-17. Format of Timer Input Select register 0 (TIS0)	
	Modification of description in Figure 6-18. Format of Timer Output Enable register m (TOEm)	
	Modification of description in 6.3.15 Port mode registers 0, 1, 3, 4, 6, 10, 14 (PM0, PM1, PM3, PM4, PM6, PM10, PM14)	
	Modification of description in 6.5.1 (1) When operation clock (f _{MCK}) specified by the CKSmn0 and CKSmn1 bits is selected (CCSmn = 0)	
	Modification of description in Table 6-6. Operations from Count Operation Enabled State to Timer count Register mn (TCRmn) Count Start	

(26/38)

Edition	Description	Chapter
Rev.2.00	Addition of title and remark to 6.5.3 Operation of counter	CHAPTER 6 TIMER ARRAY UNIT
	Modification of description, remark and addition note to Figure 6-29. Start Timing (In Capture Mode : Input Pulse Interval Measurement)	
	Modification of remark in Figure 6-31. Operation Timing (In Capture & One-count Mode : High-level Width Measurement)	
	Modification of description in 6.6.2 TOmn Pin Output Setting	
	Modification of Figures 6-34 to 6-36	
	Modification of description in Figures 6-43, 6-47, 6-55, 6-59, 6-63, 6-68, 6-78 Example of Set Contents of Registers	
	Modification of Figures 6-45, 6-49, 6-57, 6-61, 6-65 Block Diagram	
	Modification of Figures 6-48, 6-52, 6-56, 6-60, 6-64, 6-69, 6-79 Operation Procedure	
	Modification of remark in 6.8.3 Operation as multiple PWM output function	
	Rev.2.00	
Modification of 7.4.2 Shifting to HALT/STOP mode after starting operation		
Rev.2.00	Addition of caution 3 to Figure 8-4. Format of Interval Timer Control Register (ITMC)	CHAPTER 8 INTERVAL TIMER
	Modification of Figure 8-5. 12-bit Interval Timer Operation Timing (ITMCMP11 to ITMCMP0 = 0FFH, count clock: $f_{SUB} = 32.768$ kHz)	
Rev.2.00	Addition of 9.5 Cautions of clock output/buzzer output controller	CHAPTER 9 CLOCK OUTPUT/BUZZER OUTPUT CONTROLLER
	Modification of description in 10.1 Functions of Watchdog Timer, 10.4.3 Setting window open period of watchdog timer, 10.4.4 Setting watchdog timer interval interrupt	
Rev.2.00	Modification of Figure 11-1. Block Diagram of A/D Converter	CHAPTER 11 A/D CONVERTER
	Deletion of note 3 and addition of cautions 1 and 2 to Figure 11-3. Format of A/D Converter Mode Register 0 (ADM0)	
	Modification of description and addition of note 2 and caution 4 to Figure 11-4. Timing Chart When A/D Voltage Comparator Is Used	
	Addition of description to Table 11-3. A/D Conversion Time Selection	
	Modification of cautions 2, 3 in Figure 11-6. Format of A/D Converter Mode Register 1 (ADM1)	
	Modification of description and addition of note, cautions 2, 3 and remark to Figure 11-7. Format of A/D Converter Mode Register 2 (ADM2)	
	Addition of note to 11.3.5 10-bit A/D conversion result register (ADCR), and 11.3.6 8-bit A/D conversion result register (ADCRH)	
	Addition of note 3 and cautions 9, 10 to Figure 11-11. Format of Analog Input Channel Specification Register (ADS)	
	Addition of caution to 11.3.10 A/D test register (ADTES)	
	Addition of caution 3 to 11.3.11 A/D port configuration register (ADPC)	
	Addition of caution to 11.3.12 Port mode control registers 0, 3, 10, 11, 12, 14 (PMC0, PMC3, PMC10, PMC11, PMC12, PMC14)	
	Modification of description and addition of Caution to 11.3.13 Port mode register 0, 2, 3, 10, 11, 12, 14, 15 (PM0, PM2, PM3, PM10, PM11, PM12, PM14, PM15)	
	Addition of note 1 to 11.4 A/D Converter Conversion Operations	
	Modification of Figures 11-32 to 11-36	
	Modification of description in 11.8 SNOOZE Mode Function	

(27/38)

Edition	Description	Chapter
Rev.2.00	Addition of caution to 11.10 (2) Input range of ANI0 to ANI14 and ANI16 to ANI26 pins	CHAPTER 11 A/D CONVERTER
	Modification of description in 11.10 (5) Analog input (ANIn) pins	
	Modification of value in Table 11-6. Resistance and Capacitance Values of Equivalent Circuit (Reference Values)	
	Addition of note 1 to 12.1.1 3-wire serial I/O (CSI00, CSI01, CSI10, CSI11, CSI20, CSI21, CSI30, CSI31)	CHAPTER 12 SERIAL ARRAY UNIT
	Addition of note to 12.1.2 UART (UART0 to UART3)	
	Modification of Figures 12-1 and 12-2 block diagram of the serial array unit 0, 1	
	Modification of description in 12.2 (2) Lower 8/9 bits of the serial data register mn (SDRmn)	
	Modification of caution 1 in Figure 12-5. Format of Peripheral Enable Register 0 (PER0)	
	Modification of description in Figure 12-8. Format of Serial Communication Operation Setting Register mn (SCRmn)	
	Modification of description in 12.3 (5) Higher 7 bits of the serial data register mn (SDRmn)	
	Addition of note and caution 2 to Figure 12-12. Format of Serial Channel Start Register m (SSm)	
	Addition of note to Figure 12-13. Format of Serial Channel Stop Register m (STm)	
	Modification of description and addition of caution to Figure 12-18. Format of Serial Standby Control Register m (SSCm)	
	Modification of description in 12.3 (18) Port output mode registers 0, 1, 4, 5, 7 to 9, 14 (POM0, POM1, POM4, POM5, POM7 to POM9, POM14)	
	Addition of description to 12.3 (19) Port mode registers 0, 1, 3 to 5, 7 to 9, and 14 (PM0, PM1, PM3 to PM5, PM7 to PM9, and PM14)	
	Modification of caution 1 in Figure 12-24. Peripheral Enable Register 0 (PER0) Setting When Stopping the Operation by Units	
	Modification of note 1 in 12.5 Operation of 3-Wire Serial I/O (CSI00, CSI01, CSI10, CSI11, CSI20, CSI21, CSI30, CSI31) Communication	
	Modification of description in Figure 12-26, 34, 42, 50, 58, 64, 77, 85, 105, 109, 112 (Example of Contents of Registers)	
	Modification of Figure 12-28, 29, 36, 37, 44, 45, 52, 53, 60, 61, 66, 67, 79, 80, 82, 84, 87, 88, 90, 93, 95, 106, 108, 111, 114, 116 (flow chart)	
	Addition of description of note to 12.5.4 Slave transmission, 12.5.5 Slave reception, 12.5.6 Slave transmission/reception	
	Modification of description in 12.5.7 SNOOZE mode function	
	Modification of caution in Figures 12-72 and 12-74	
	Modification of description in Table 12-2. Selection of Operation Clock For 3-Wire Serial I/O	
	Addition of description to 12.6 Operation of UART (UART0 to UART3) Communication	
	Modification of description in 12.6.1 UART transmission and 12.6.2 UART reception	
	Modification of caution in Figure 12-86. Initial Setting Procedure for UART Reception	
	Addition of description and modification of caution to 12.6.3 SNOOZE mode function	
	Modification of note and caution in Figure 12-91. Timing Chart of SNOOZE Mode Operation (Normal operation mode)	
	Modification of caution in Figure 12-92. Timing Chart of SNOOZE Mode Operation (Abnormal Operation <1>)	
	Modification of note 1 and caution 1 in Figure 12-94. Timing Chart of SNOOZE Mode Operation (Abnormal Operation <2>)	
	Modification of description in Table 12-3. Selection of Operation Clock For UART	

(28/38)

Edition	Description	Chapter
Rev.2.00	Modification of description and note in 12.7.1 LIN transmission and 12.7.2 LIN reception	CHAPTER 12 SERIAL ARRAY UNIT
	Modification of Figure 12-99. Master Transmission Operation of LIN	
	Modification of Figure 12-100. Flowchart for LIN Transmission	
	Modification of Figure 12-101. Reception Operation of LIN	
	Modification of Figure 12-102. Flowchart for LIN Reception	
	Modification of description in 12.8.1 Address field transmission, 12.8.2 Data transmission, and 12.8.3 Data reception	
	Addition of caution of description to 12.8.5 Calculating transfer rate	
	Modification of description in example of setting an I ² C transfer rate	
	Modification of description in Figure 12-117. Processing Procedure in Case of Parity Error (ACK error) in Simplified I ² C Mode	
	Modification of Figure 13-9. Format of IICA Control Register n1 (IICCTLn1) (2/2)	
	Modification of 13.3 (6) IICA low-level width setting register n (IICWLn)	
	Modification of 13.5.13 Wakeup function	
	Modification of Figure 13-28, 13-29, 13-30	
	Modification of 13.5.17 (2) (d) Start ~ Address ~ Data ~ Start ~ Address ~ Data ~ Stop	
	Modification of 13.5.17 (3) (d) Start ~ Code ~ Data ~ Start ~ Address ~ Data ~ Stop	
	Modification of Figure 14-1. Block Diagram of Multiplier and Divider/Multiply-Accumulator	CHAPTER 14 MULTIPLIER AND DIVIDER/MULTIPLY-ACCUMULATOR
	Modification of caution 1 to 14. 2 (2) Multiplication/division data register B (MDBL, MDBH)	
	Modification of caution 2 to 14. 2 (3) Multiplication/division data register C (MDCL, MDCH)	
	Modification of description in Figure 14-5. Format of Multiplication/Division Control Register (MDUC)	
	Modification of description in 14.4.1 Multiplication (unsigned) operation, and modification of value in Figure 14-6. Timing Diagram of Multiplication (Unsigned) Operation (2 × 3 = 6)	
	Modification of description in 14.4.2 Multiplication (signed) operation, and modification of value in Figure 14-7. Timing Diagram of Multiplication (Signed) Operation (-2 × 32767 = -65534)	
	Modification of description in 14.4.3 Multiply-accumulation (unsigned) operation	
	Modification of value in Figure 14-8. Timing Diagram of Multiply-Accumulation (Unsigned) Operation	
	Addition of description to 14.4.4 Multiply-accumulation (signed) operation	
	Modification of value in Figure 14-9. Timing Diagram of Multiply-Accumulation (signed) Operation	
	Modification of description in 14.4.5 Division operation	
	Modification of value in Figure 14-10. Timing Diagram of Division Operation (Example: 35 ÷ 6 = 5, Remainder 5)	
	Addition of description to the beginning of the chapter	
	Deletion of caution 2 in Figure 16-2. Format of Interrupt Request Flag Registers (IF0L, IF0H, IF1L, IF1H, IF2L, IF2H, IF3L) (128-pin)	
	Addition of remark 1 to Table 16-3. Ports Corresponding to EGPn and EGNn bits	
	Modification of value and addition of note in Table 16-4. Time from Generation of Maskable Interrupt Until Servicing	
	Modification of Figure 16-8. Interrupt Request Acknowledgment Timing (Minimum Time) and Figure 16-9. Interrupt Request Acknowledgment Timing (Maximum Time)	

(29/38)

Edition	Description	Chapter	
Rev.2.00	Modification of Table 16-5. Relationship Between Interrupt Requests Enabled for Multiple Interrupt Servicing During Interrupt Servicing	CHAPTER 16 INTERRUPT FUNCTION	
	Deletion of caution in 16.4.4 Interrupt request hold		
	Addition of caution 1 and modification of description and caution 2 in Figure 17-2. Format of Key Return Mode Register (KRM)	CHAPTER 17 KEY INTERRUPT FUNCTION	
	Modification of Table 18-1. Operating Statuses in HALT Mode	CHAPTER 18 STANDBY FUNCTION	
	Addition of note 1 and modification of note 2 in Figure 18-3. HALT Mode Release by Interrupt Request Generation		
	Modification of description and note in Figure 18-4. HALT Mode Release by Reset		
	Modification of description in Table 18-2. Operating Statuses in STOP Mode		
	Modification of note in Figure 18-5. STOP Mode Release by Interrupt Request Generation		
	Modification of note in Figure 18-6. STOP Mode Release by Reset		
	Modification of description in 18.3.3 (1) SNOOZE mode setting and operating statuses		
	Modification of description in Table 18-3. Operating Statuses in SNOOZE Mode		
	Modification of Figures 19-2 to 19-4		CHAPTER 19 RESET FUNCTION
	Modification of description in Table 19-1. Operation Statuses During Reset Period		
	Modification of note 2 in Table 19-2. Hardware Statuses After Reset Acknowledgment		
	Modification of caution 3 to Figure 19-5. Format of Reset Control Flag Register (RESF)		
	Modification of description and notes in Figure 20-2. Timing of Generation of Internal Reset Signal by Power-on-reset Circuit and Voltage Detector	CHAPTER 20 POWER-ON-RESET CIRCUIT	
	Modification of Figure 21-1. Block Diagram of Voltage Detector	CHAPTER 21 VOLTAGE DETECTOR	
	Modification of description in Figure 21-2. Format of Voltage Detection Register (LVIM)		
	Addition of figure to Table 21-1. LVD Operation Mode and Detection Voltage Settings for User Option Byte (000C1H)		
	Modification of Figures 21-4 to 21-6		
	Addition of description and Figure 21-7, 21-8 to 21.4.3 When used as interrupt and reset mode		
	Modification of remark in 22.1 Overview of Safety Functions		CHAPTER 22 SAFETY FUNCTIONS
	Addition of description and caution to 22.3.1 Flash memory CRC operation function (high-speed CRC)		
	Modification of Figure 22-3. Flowchart of Flash Memory CRC Operation Function (High-speed CRC)		
	Addition of description and caution to 22.3.2 CRC operation function (general-purpose CRC)		
	Modification of Figure 22-6. CRC Operation Function (General-Purpose CRC)		
	Modification of caution in Figure 22-7. Format of RAM Parity Error Control Register (RPECTL)		
	Modification of Figure 22-10. Invalid access detection area		
	Addition of remark to Figure 22-11. Format of Invalid Memory Access Detection Control Register (IAWCTL)		
	Addition of description to 22.3.8 A/D test function		
	Addition of Figure (move from 2.2 Description to Pin Function (preceding editions))	CHAPTER 23 REGULATOR	
	Modification of description in Figure 24-1. Format of User Option Byte (000C0H/010C0H)	CHAPTER 24 OPTION BYTE	
Modification of Figure 24-2. Format of User Option Byte (000C1H/010C1H)			

(30/38)

Edition	Description	Chapter
Rev.2.00	Modification of note in Table 25-1. Wiring Between RL78/G13 and Dedicated Flash Memory Programmer	CHAPTER 25 FLASH MEMORY
	Modification of description in 25.1.1 Programming Environment and modification of note in 25.1.2 Communication Mode	
	Addition of description to 25.2 Writing to Flash Memory by Using External Device (that Incorporates UART)	
	Modification of note in 25.2.2 Communication Mode	
	Addition of remark to 25.3 Connection of Pins on Board	
	Modification of description and addition of remark to 25.4.1 Data flash overview	
	Modification of Figure 25-8. Setting of Flash Memory Programming Mode	
	Modification of Table 25-5. Programming Modes and Voltages at Which Data Can Be Written, Erased, or Verified	
	Modification of description in Table 25-10. Example of Signature Data	
	Addition of description and caution to 25.6 Security Settings	
	Addition of caution 3 to 25.7 Flash Memory Programming by Self-Programming and modification of value in Table 25-13. Programming Modes and Voltages at Which Data Can Be Written, Erased, or Verified	
	Modification of value in Table 25-13. Programming Modes and Voltages at Which Data Can Be Written, Erased, or Verified	
	Addition of Figure 26-1. Connection Example of E1 On-chip Debugging Emulator and RL78/G13	
	Modification of Flag status	CHAPTER 28 INSTRUCTION SET
	Addition of cautions 2, 3 to CHAPTER 29 ELECTRICAL SPECIFICATIONS (deletion of Pins Mounted According to Product)	CHAPTER 29 ELECTRICAL SPECIFICATIONS
	Addition of description, note 3, and remark 2 to 29.1 Absolute Maximum Ratings	
	Modification of 29.2 Oscillator Characteristics (Recommended Oscillator Constants move to 5.7 Resonator and Oscillator Constants)	
	Addition of note 2 to 29.2.2 On-chip oscillator characteristics	
	Addition of note 4 to 29.3.1 Pin characteristics	
	Modification of note in 29.3.2 Supply current characteristics	
	Addition of note to 29.3.2 Supply current characteristics	
	Deletion of target, and change to formally standard of 29.3.2 (3) 128-pin products, and flash ROM: 384 to 512 KB of 44- to 100-pin products	
	Addition of description and note 7 to 29.3.2 (4) Common to RL78/G13 all products	
	Addition of figure to 29.4 AC Characteristics	
	Modification of caution in 29.5.1 Serial array unit	
	Deletion of remark to 29.5.1 Serial array unit	
	Modification of value in 29.5.1 (7) Communication at different potential (2.5 V, 3 V) ($f_{MCK}/2$) (CSI mode) (master mode, SCKp... internal clock output, corresponding CSI00 only)	

(31/38)

Edition	Description	Chapter	
Rev.2.00	Addition of description and deletion of value in 29.5.1 (9) Communication at different potential (1.8 V, 2.5 V, 3 V) (CSI mode) (slave mode, SCKp... external clock input)	CHAPTER 29 ELECTRICAL SPECIFICATIONS	
	Addition of value to 29.5.2 Serial interface IICA		
	Addition of description to 29.6.1 A/D converter characteristics and 29.6.2 Temperature sensor characteristics		
	Modification of description in 29.6.4 LVD circuit characteristics		
	Modification of description in 29.9 Timing Specs for Switching Flash Memory Programming Modes		
	Addition of the products of industrial application		CHAPTER 30 PACKAGE DRAWINGS
	Modification of description in 30.11 64-pin products		
Rev.1.00	Change the internal high-speed oscillator to high-speed on-chip oscillator	Throughout	
	Change the internal low-speed oscillator to low-speed on-chip oscillator		
	Deletion of target in ELECTRICAL SPECIFICATIONS		
Rev.1.00	Expose the function for peripheral I/O redirection register (PIOR)	CHAPTER 1 OUTLINE	
	Change of note 1 to note 3		
	Change of note 1		
	Expose the function for peripheral I/O redirection register (PIOR)		CHAPTER 2 PIN FUNCTIONS
	Change of 2.1.15 Pins for each product (pins other than port pins)		
	Addition of description for digital I/O/analog input to 2.2 Description of Pin Functions		
Change of description for pull-up resistor option register in 2.2 Description of Pin Functions			
Addition of remark to 2.2.17 (2) V _{SS} , EV _{SS0} , EV _{SS1}			
Change of description in 2.2.19 REGC			
Rev.1.00	Addition of remark 3 to Table 2-3. Connection of Unused Pins (128-pin products) (2/4)	CHAPTER 3 CPU ARCHITECTURE	
	Change of Figure 2-1. Pin I/O Circuit List		
	Change of Figure 3-1 to Figure 3-3		
	Change of note 1 in Figure 3-3, Figure 3-4, Figure 3-8, Figure 3-10		
	Change of Table 3-3. Vector Table		
	Change of description in 3.1.2 Mirror area		
	Change of caution 2 in 3.1.3 Internal data memory space		
	Change of Figure 3-12 to Figure 3-14		
	Change of note 1 in Figure 3-14, Figure 3-15, Figure 3-19, Figure 3-21		
	Change of caution 3 in 3.2.1 (3) Stack pointer (SP)		
	Change of caution 2 in 3.2.2 General-purpose registers		
	Change and addition of note in Table 3-6. Extended SFR (2nd SFR) List (2/8)		
	Change of Table 3-6. Extended SFR (2nd SFR) List (7/8)		
	Change of Figure 3-31. Outline of Table Indirect Addressing		
	Addition of Table 4-x. Settings of Registers When Using Port x		CHAPTER 4 PORT FUNCTIONS
	Change of Block Diagram in 4.2 Port Configuration to be corresponded to 128-pin products		
Change of description for Digital I/O/analog input in 4.2 Port Configuration			
Change of description for reset signal generation in 4.2 Port Configuration			
Change of Figure 4-10. Block Diagram of P13			
Change of Figure 4-15. Block Diagram of P20 to P27			

(32/38)

Edition	Description	Chapter		
Rev.1.00	Change of Figure 4-23. Block Diagram of P43, P44	CHAPTER 4 PORT FUNCTIONS		
	Change of Figure 4-25. Block Diagram of P46			
	Change of Figure 4-26. Block Diagram of P47			
	Change of Figure 4-52. Block Diagram of P121 and P122			
	Change of Figure 4-53. Block Diagram of P123 and P124			
	Change of description in 4.2.14 Port 13			
	Change of Figure 4-64. Block Diagram of P150 to P156			
	Change of Table 4-21. PMxx, Pxx, PUxx, PIMxx, POMxx, PMCxx registers and the bits mounted on each product (20-pin products to 64-pin products)			
	Change of Table 4-22. PMxx, Pxx, PUxx, PIMxx, POMxx, PMCxx registers and the bits mounted on each product (80-pin products to 128-pin products) (3/4)			
	Change of Figure 4-70. Format of Port Mode Control Register			
	Change of cautions 1 and 2 in Figure 4-72. Format of Peripheral I/O Redirection Register (PIOR)			
	Change of description in 4.3 (9) Global digital input disable register (GDIDIS)			
	Change of description in 4.4.4 Connecting to external device with different potential (1.8 V, 2.5 V, 3 V)			
	Change of Table 4-23. Settings of Port Mode Register, and Output Latch When Using Alternate Function			
	Addition of note 3 to Table 4-23. Settings of Port Mode Register, and Output Latch When Using Alternate Function			
	Addition of 4.6 Cautions When Using Port Function			
			Change of description in 5.1 (2) Subsystem clock	CHAPTER 5 CLOCK GENERATOR
			Change of Figure 5-1. Block Diagram of Clock Generator	
	Change and addition of note to Figure 5-2. Format of Clock Operation Mode Control Register (CMC)			
	Change of description and deletion of note 2 in 5.3.2 System clock control register (CKC)			
	Change of Figure 5-6. Format of Oscillation Stabilization Time Select Register (OSTS)			
	Deletion of note 4 in Figure 5-7. Format of Peripheral Enable Register 0 (PER0)			
	Change of description and deletion of caution in 5.3.7 Operation speed mode control register (OSMC)			
	Change of cautions 2, 3 in Figure 5-9. Format of High-speed On-chip Oscillator Frequency Select Register (HOCODIV)			
	Change of 5.3.9 High-speed on-chip oscillator trimming register (HIOTRM)			
	Addition of note 3 to Figure 5-14. Clock Generator Operation When Power Supply Voltage Is Turned On			
	Change of 5.6.1 Example of setting high-speed on-chip oscillator			
	Change of description in 5.6.2 Example of setting X1 oscillation clock			
	Change of (6) and (8) in Table 5-3. CPU Clock Transition and SFR Register Setting Examples			
	Change of Table 5-6 and Table 5-7			

(33/38)

Edition	Description	Chapter
Rev.1.00	Change of Table 6-2. Timer I/O Pins provided in Each Product	CHAPTER 6 TIMER ARRAY UNIT
	Change of 6.2.1 Timer count register mn (TCRmn)	
	Change of caution in 6.3.2 Timer clock select register m (TPSm)	
	Addition of note to Table 6-4. Interval Times Available for Operation Clock CKSm2 or CKSm3	
	Change of caution in 6.3.3 Timer mode register mn (TMRmn)	
	Change of Figure 6-8. Format of Timer Mode Register mn (TMRmn)	
	Change of description in 6.3.5 Timer channel enable status register m (TEm)	
	Change of description in 6.3.6 Timer channel start register m (TSm)	
	Change of Figure 6-18. Format of Input Switch Control Register (ISC)	
	Addition of remark to 6.3.15 Port mode registers 0, 1, 3, 4, 6, 10, 14 (PM0, PM1, PM3, PM4, PM6, PM10, PM14)	
	Change of description in 6.4.1 Basic rules of simultaneous channel operation function	
	Change of description in 6.5.2 (e) Start timing in capture & one-count mode (when high-level width is measured)	
	Change of Figure 6-27. Start Timing (In Capture & One-count Mode)	
	Change of Figure 6-30. TOMn Pin Output Status at Toggle Output (TOMmn = 0)	
	Change of note in Figure 6-37, Figure 6-39, Figure 6-43, Figure 6-51, Figure 6-55, Figure 6-57, Figure 6-59, Figure 6-64, Figure 6-69, Figure 6-74	
	Change of operation clock (f _{CK}) selection in Figure 6-39, Figure 6-43, Figure 6-51, Figure 6-55, Figure 6-59	
	Addition of note to Figure 6-49, Figure 6-53	
	Change of description in 6.7.6 Operation as delay counter	
	Addition of 6.9 Cautions When Using Timer Array Unit	
	Change of caution in 7.1 Functions of Real-time Clock	CHAPTER 7 REAL-TIME CLOCK
	Change of figure and caution in Figure 7-1. Block Diagram of Real-time Clock	
	Deletion of caution 4 of 7.3 (1) Peripheral enable register 0 (PER0)	
	Change of caution in 7.3 (2) Operation speed mode control register (OSMC)	
	Change of Figure 7-5. Format of Real-time Clock Control Register 1 (RTCC1) (2/2)	
	Change of description and caution in 7.3 (5) Second count register (SEC) to 7.3 (11) Year count register (YEAR)	
	Change of description in 7.4.3 Reading/writing real-time clock	
	Addition of caution 2 to Figure 7-20. Procedure for Writing Real-time Clock	
	Change of Figure 7-22. 1 Hz Output Setting Procedure	
	Change of description in 8.1 Functions of Interval Timer	CHAPTER 8 INTERVAL TIMER
	Change of caution 1 in Figure 8-4. Format of Interval Timer Control Register (ITMC)	
	Change of note and addition of remark to Figure 9-1. Block Diagram of Clock Output/Buzzer Output Controller	CHAPTER 9 CLOCK OUTPUT/BUZZER OUTPUT CONTROLLER
	Change of Figure 9-2. Format of Clock Output Select Register n (CKSn)	
	Change of 9.3 (2) Port mode register 1, 3, 5, 14 (PM1, PM3, PM5, PM14)	

(34/38)

Edition	Description	Chapter
Rev.1.00	Change of caution 4 and deletion of caution 5 in 10.4.1 Controlling operation of watchdog timer	CHAPTER 10 WATCHDOG TIMER
	Deletion of caution of Table 10-3. Setting of Overflow Time of Watchdog Timer	
	Deletion of caution 1 and change of remark in Table 10-4. Setting Window Open Period of Watchdog Timer	
	Change of description in 11.1 Function of A/D Converter	CHAPTER 11 A/D CONVERTER
	Change of Figure 11-1. Block Diagram of A/D Converter	
	Change of description in 11.2 Configuration of A/D Converter	
	Change of 11.3 Registers Used in A/D Converter	
	Addition of note to Table 11-1. Settings of ADCS and ADCE Bits	
	Change of Table 11-2. Setting and Clearing Conditions for ADCS Bit	
	Change of Table 11-3. A/D Conversion Time Selection	
	Change of Figure 11-7. Format of A/D Converter Mode Register 2 (ADM2)	
	Change of Figure 11-8. ADRCK Bit Interrupt Signal Generation Range	
	Change of Figure 11-11. Format of Analog Input Channel Specification Register (ADS)	
	Change of Figure 11-14. Format of A/D Test Register (ADTES)	
	Change of description in 11.3.11 A/D port configuration register (ADPC)	
	Change of 11.3.12 Port mode control registers 0, 3, 10, 11, 12, 14 (PMC0, PMC3, PMC10, PMC11, PMC12, PMC14)	
	Change of 11.3.13 Port mode register 0, 2, 3, 10, 11, 12, 14, 15 (PM0, PM2, PM3, PM10, PM11, PM12, PM14, PM15)	
	Change from "power down status" to "stop status" in 11.6 A/D Converter Operation Modes	
	Change of 11.7.4 Setup when using temperature sensor (example for software trigger mode and one-shot conversion mode)	
	Addition of description to 11.8 (1) If an interrupt is generated after A/D conversion ends	
	Change of 11.10 (2) Input range of ANI0 to ANI14 and ANI16 to ANI26 pins	
	Change of Table 11-6. Resistance and Capacitance Values of Equivalent Circuit (Reference Values)	
	Addition of description of CSI30, CSI31, UART3, IIC30, IIC31 (corresponding to 128-pin products)	CHAPTER 12 SERIAL ARRAY UNIT
	Change of description to be corresponded to 128-pin products	
	Change of description to CSI-UART channel corresponding SNOOZE mode	
	Change of description to UART channel corresponding 9-bit data communication	
	Change of caution in CHAPTER 12 SERIAL ARRAY UNIT	
	Change of description in 12.1.3 Simplified I ² C (IIC00, IIC01, IIC10, IIC11, IIC20, IIC21, IIC30, IIC31)	
	Change of note 1 in Table 12-1. Configuration of Serial Array Unit)	
	Change of Figure 12-2. Block Diagram of Serial Array Unit 1	
	Addition of note to Figure 12-3 and 12-4	
	Change of caution 1 in Figure 12-5. Format of Peripheral Enable Register 0 (PER0)	
	Change of Figure 12-6. Format of Serial Clock Select Register m (SPSm)	

(35/38)

Edition	Description	Chapter
Rev.1.00	Change of note 2 and caution in Figure 12-8. Format of Serial Communication Operation Setting Register mn (SCRmn)	CHAPTER 12 SERIAL ARRAY UNIT
	Change of description in 12.3 (5) Higher 7 bits of the serial data register mn (SDRmn)	
	Addition of caution 2 to Figure 12-12. Format of Serial Channel Start Register m (SSm)	
	Change of description in 12.3 (13) Serial output level register m (SOLm)	
	Change of note and addition of caution to 12.3 (14) Serial standby control register m (SSCm)	
	Change of Figure 12-19. Format of Input Switch Control Register (ISC)	
	Change of flowchart for each operation mode	
	Change of Figure 12-86. Initial Setting Procedure for UART Reception	
	Change of Figure 12-88. Procedure for Resuming UART Reception	
	Change of note in 12.8.1 Address field transmission to 12.8.3 Data reception	
	Change of Figure 13-6. Format of IICA Control Register 00 (IICCTL00)	CHAPTER 13 SERIAL INTERFACE IICA
	Change of Figure 13-7. Format of IICA Status Register 0 (IICS0)	
	Change of 13.4.2 Setting transfer clock by using IICWL0 and IICWH0 registers	
	Change of description in Figure 13-33. Example of Slave to Master Communication (8-Clock Wait Is Selected for Master, 9-Clock Wait Is Selected for Slave) (1/3)	
	Change of Figure 14-6. Timing Diagram of Multiplication (Unsigned) Operation ($2 \times 3 = 6$)	CHAPTER 14 MULTIPLIER AND DIVIDER/MULTIPLY-ACCUMULATOR
	Change of description in 14.4.3 Multiply-accumulation (unsigned) operation	
	Change of Figure 14-8. Timing Diagram of Multiply-Accumulation (Unsigned) Operation ($2 \times 3 + 3 = 9 \rightarrow 32767 \times 2 + 4294901762 = 0$ (over flow generated))	
	Change of description in 14.4.4 Multiply-accumulation (signed) operation	
	Change of Figure 14-9. Timing Diagram of Multiply-Accumulation (signed) Operation ($2 \times 3 + (-4) = 2 \rightarrow 32767 \times (-1) + (-2147483647) = -2147450882$ (overflow occurs.))	CHAPTER 15 DMA CONTROLLER
	Change of Table 15-2 Internal RAM Area other than the General-purpose Registers	
	Change of (4) and addition of (6) to 15.6 Cautions on Using DMA Controller	CHAPTER 16 INTERRUPT FUNCTION
	Change of Table 16-1. Interrupt Source List	
	Change of Table 16-2. Flags Corresponding to Interrupt Request Sources	
	Change of caution in 16.4.2 Software interrupt request acknowledgment	CHAPTER 18 STANDBY FUNCTION
	Change of cautions 2, 4 and remark, and addition of caution 3 to 18.1.1 Standby function	
	Addition of note to Figure 18-3 and Figure 18-4.	
	Change of remark in 18.2.2 (1) STOP mode setting and operating statuses	
	Change of remark 2, caution 2 in Table 18-2. Operating Statuses in STOP Mode	
	Addition of note to Figure 18-5 and Figure 18-6.	
	Change of remark in 18.2.3 (1) SNOOZE mode setting and operating statuses	
	Change of remark 2 in Table 18-3. Operating Statuses in SNOOZE Mode	CHAPTER 19 RESET FUNCTION
	Change of description and deletion caution 3 in CHAPTER 19 RESET FUNCTION	
	Change of Figure 19-2. to Figure 19-4.	
Change of Table 19-2. Hardware Statuses After Reset Acknowledgment (1/4) and change of note 2		
Change of values of LVIM, LVIS of note 2 in Table 19-2. Hardware Statuses After Reset Acknowledgment (4/4)		

(36/38)

Edition	Description	Chapter
Rev.1.00	Change of figure and addition of note 4 to Figure 20-2. Timing of Generation of Internal Reset Signal by Power-on-reset Circuit and Voltage Detector (1/2)	CHAPTER 20 POWER-ON-RESET CIRCUIT
	Change of note 4 and addition of note 5 to Figure 20-2. Timing of Generation of Internal Reset Signal by Power-on-reset Circuit and Voltage Detector (2/2)	
	Change of Figure 20-3. Example of Software Processing After Reset Release	
Rev.1.00	Change of description in 21.1 Functions of Voltage Detector	CHAPTER 21 VOLTAGE DETECTOR
	Change of note 2 and addition of notes 3, 4 to Figure 21-2. Format of Voltage Detection Register (LVIM)	
	Change of Figure 21-3. Format of Voltage Detection Level Select Register (LVIS)	
	Change of Table 21-1. LVD Operation Mode and Detection Voltage Settings for User Option Byte (000C1H/010C1H)	
	Change of description in 21.4.1 When used as reset mode	
	Change of Figure 21-4. Timing of Voltage Detector Internal Reset Signal Generation (Option Byte LVIMDS1, LVIMDS0 = 1, 1)	
	Change of description in 21.4.2 When used as interrupt mode	
	Change of Figure 21-5. Timing of Voltage Detector Internal Interrupt Signal Generation (Option Byte LVIMDS1, LVIMDS0 = 0, 1)	
	Change of description in 21.4.3 When used as interrupt and reset mode	
	Change of Figure 21-6. Timing of Voltage Detector Reset Signal and Interrupt Signal Generation (Option Byte LVIMDS1, LVIMDS0 = 1, 0)	
	Change of Figure 21-8. Delay from the time LVD reset source is generated until the time LVD reset has been generated or released	
	Change of all	
	Rev.1.00	
Rev.1.00	Change of description in 24.1.1 User option byte (000C0H to 000C2H/010C0H to 010C2H)	CHAPTER 24 OPTION BYTE
	Change of caution in Figure 24-1. Format of User Option Byte (000C0H/010C0H)	
	Change of Figure 24-2. Format of User Option Byte (000C1H/010C1H) (1/2)	
	Change of Figure 24-3. Format of Option Byte (000C2H/010C2H)	
Rev.1.00	Change of Table 25-1. Wiring Between RL78/G13 and Dedicated Flash Memory Programmer	CHAPTER 25 FLASH MEMORY
	Change of 25.1.2 Communication Mode	
	Change of description in 25.2.2 Communication Mode	
	Change of description in 25.4.1 Data flash overview	
	Change of description in 25.4.3 Procedure for accessing data flash memory	
	Change of description in 25.5.2 Flash memory programming mode	
	Addition of 25.5.5 Description of signature data	
	Change of Table 25-12. Setting Security in Each Programming Mode	
	Change of Table 25-14. Relationship between Flash Shield Window Function Setting/Change Methods and Commands	

(37/38)

Edition	Description	Chapter
Rev.1.00	Change of Figure 26-2. Memory Spaces Where Debug Monitor Programs Are Allocated	CHAPTER 26 ON-CHIP DEBUG FUNCTION
	Change of description and deletion of remark in CHAPTER 28 INSTRUCTION SET	CHAPTER 28 INSTRUCTION SET
	Change of 28.2 Operation List	
	Addition of caution for pins of each products	CHAPTER 29 ELECTRICAL SPECIFICATIONS
	Change of 29.2 Absolute Maximum Ratings	
	Change of 29.3.2 On-chip oscillator characteristics	
	Addition of 29.3.4 Recommended Oscillator Constants	
	Change of 29.4.1 Pin characteristics	
	Change of 29.4.2 Supply current characteristics	
	Change of 29.5.1 Basic operation	
	Change of 29.6.1 Serial array unit	
	Change of 29.7.1 A/D converter characteristics	
	Change of 29.7.2 Temperature sensor characteristics and 29.7.3 POR circuit characteristics	
	Change of Supply Voltage Rise Time	
	Change of 29.8 Data Memory STOP Mode Low Supply Voltage Data Retention Characteristics and 29.9 Flash Memory Programming Characteristics	
	Change of 29.10 Timing Specs for Switching Modes	
Addition of CHAPTER 30 PACKAGE DRAWINGS	CHAPTER 30 PACKAGE DRAWINGS	
Rev.0.07	Change of 1.1 Features	CHAPTER 1 OUTLINE
	Change of 1.6 Outline of Functions	
	Change of 2.1 (5) 128-pin products	CHAPTER 2 PIN FUNCTIONS
	Change of 2.1.12 80-pin products	
	Change of 2.1.13 100-pin products	
	Change of 2.1.14 128-pin products	
	Change of 2.1.15 Pins for each product (pins other than port pins) (6/6)	
	Change of caution in 2.2.5 (2) Control mode	
	Change of 2.2.17 V_{DD} , EV_{DD0} , EV_{DD1} , V_{SS} , EV_{SS0} , EV_{SS1}	
	Change of Type 37-C in Figure 2-1. Pin I/O Circuit List (1/2)	
	Change of Figure 3-1 to Figure 3-10	CHAPTER 3 CPU ARCHITECTURE
	Change of description of 3.1.2 Mirror area	
	Change of Figure 3-11. Format of Configuration of Processor Mode Control Register (PMC)	
	Change of caution in 3.1.3 Internal data memory space	
	Change of Figure 3-12 to Figure 3-21	
	Change of caution in 3.2.1 (3) Stack pointer (SP)	
	Change of caution in 3.2.2 General-purpose registers	

(38/38)

Edition	Description	Chapter
Rev.0.07	Change of Table 4-1 (5) 128-pin products	CHAPTER 4 PORT FUNCTIONS
	Deletion of note and caution 3 in 4.2.5 Port 4	
	Change of Figure 4-56. Block Diagram of P137	
	Change of Table 4-7. Settings of Port Mode Register, and Output Latch When Using Alternate Function (1/4)	
	Change of 5.1 (2) Subsystem clock	CHAPTER 5 CLOCK GENERATOR
	Change of Figure 5-1. Block Diagram of Clock Generator	
	Change of Figure 5-10. Format of Internal High-Speed Oscillator Trimming Register (HIOTRM)	
	Change of Figure 5-15. CPU Clock Status Transition Diagram	CHAPTER 6 TIMER ARRAY UNIT
	Change of note 2 in Figure 6-8. Format of Timer Mode Register mn (TMRmn) (4/4)	
	Change of 6. 3 (6) Timer channel start register m (TSM)	
	Change of Figure 6-42. Operation Procedure of Interval Timer/Square Wave Output Function (2/2)	
	Change of Figure 6-46. Operation Procedure When External Event Counter Function Is Used	
	Change of Figure 6-50. Operation Procedure When Frequency Divider Function Is Used	
	Change of Figure 6-62. Operation Procedure When Delay Counter Function Is Used	
	Change of Figure 6-67. Operation Procedure of One-Shot Pulse Output Function (2/2)	
	Change of Figure 6-72. Operation Procedure When PWM Function Is Used (2/2)	CHAPTER 19 RESET FUNCTION
	Change of Figure 6-77. Operation Procedure When Multiple PWM Output Function Is Used (2/2)	
	Addition of cautions to Figure 19-5. Format of Reset Control Flag Register (RESF)	CHAPTER 22 SAFETY FUNCTIONS
	Addition of caution to Figure 22-6. Format of RAM Parity Error Control Register (RPECTL)	
	Change of Table 25-1. Wiring Between RL78/G13 and Dedicated Flash Memory Programmer	CHAPTER 25 FLASH MEMORY
	Change of Figure 25-2. Communication with Dedicated Flash Memory Programmer	
	Change of Table 25-2. Pin Connection	
	Change of description of 25.4.1 Data flash overview	
	Change of description of 25.5.2 Flash memory programming mode	
	Change of Table 25-7. Flash Memory Control Commands	
	Addition of caution to 25.7 Flash Memory Programming by Self-Programming	
	Change of 29.10 Timing Specs for Switching Modes	CHAPTER 29 ELECTRICAL SPECIFICATIONS (TARGET)

RL78/G13 User's Manual: Hardware

Publication Date: Rev.3.80 Oct 31, 2024

Published by: Renesas Electronics Corporation

RL78/G13



Renesas Electronics Corporation

R01UH0146EJ0380