



# Tsi384™

# Evaluation Board User Manual

60E1000\_MA001\_08

September 2009

6024 Silver Creek Valley Road, San Jose, California 95138  
Telephone: (800) 345-7015 • (408) 284-8200 • FAX: (408) 284-2775  
Printed in U.S.A.  
©2009 Integrated Device Technology, Inc.

#### GENERAL DISCLAIMER

Integrated Device Technology, Inc. reserves the right to make changes to its products or specifications at any time, without notice, in order to improve design or performance and to supply the best possible product. IDT does not assume any responsibility for use of any circuitry described other than the circuitry embodied in an IDT product. The Company makes no representations that circuitry described herein is free from patent infringement or other rights of third parties which may result from its use. No license is granted by implication or otherwise under any patent, patent rights or other rights, of Integrated Device Technology, Inc.

#### CODE DISCLAIMER

Code examples provided by IDT are for illustrative purposes only and should not be relied upon for developing applications. Any use of the code examples below is completely at your own risk. IDT MAKES NO REPRESENTATIONS OR WARRANTIES OF ANY KIND CONCERNING THE NONINFRINGEMENT, QUALITY, SAFETY OR SUITABILITY OF THE CODE, EITHER EXPRESS OR IMPLIED, INCLUDING WITHOUT LIMITATION ANY IMPLIED WARRANTIES OF MERCHANTABILITY, FITNESS FOR A PARTICULAR PURPOSE, OR NON-INFRINGEMENT. FURTHER, IDT MAKES NO REPRESENTATIONS OR WARRANTIES AS TO THE TRUTH, ACCURACY OR COMPLETENESS OF ANY STATEMENTS, INFORMATION OR MATERIALS CONCERNING CODE EXAMPLES CONTAINED IN ANY IDT PUBLICATION OR PUBLIC DISCLOSURE OR THAT IS CONTAINED ON ANY IDT INTERNET SITE. IN NO EVENT WILL IDT BE LIABLE FOR ANY DIRECT, CONSEQUENTIAL, INCIDENTAL, INDIRECT, PUNITIVE OR SPECIAL DAMAGES, HOWEVER THEY MAY ARISE, AND EVEN IF IDT HAS BEEN PREVIOUSLY ADVISED ABOUT THE POSSIBILITY OF SUCH DAMAGES. The code examples also may be subject to United States export control laws and may be subject to the export or import laws of other countries and it is your responsibility to comply with any applicable laws or regulations.

#### LIFE SUPPORT POLICY

Integrated Device Technology's products are not authorized for use as critical components in life support devices or systems unless a specific written agreement pertaining to such intended use is executed between the manufacturer and an officer of IDT.

1. Life support devices or systems are devices or systems which (a) are intended for surgical implant into the body or (b) support or sustain life and whose failure to perform, when properly used in accordance with instructions for use provided in the labeling, can be reasonably expected to result in a significant injury to the user.
2. A critical component is any components of a life support device or system whose failure to perform can be reasonably expected to cause the failure of the life support device or system, or to affect its safety or effectiveness.

IDT, the IDT logo, and Integrated Device Technology are trademarks or registered trademarks of Integrated Device Technology, Inc.

# Contents

<b>About this Document.....</b>	<b>5</b>
Related Information .....	5
Acronyms .....	5
Revision History .....	5
<b>1. Board Design .....</b>	<b>9</b>
1.1 Overview .....	9
1.2 PCI/X Interface .....	10
1.2.1 Overview .....	10
1.2.2 IDSEL Signals .....	11
1.2.3 Interrupt Signals .....	11
1.2.4 PCI Pull-up Signals .....	12
1.2.5 Arbitration .....	12
1.3 PCIe Interface.....	12
1.4 Power Management .....	13
1.4.1 Power Regulation.....	13
1.4.2 Power Requirements .....	13
1.4.3 Power Sequencing .....	15
1.4.4 System Power Design .....	15
1.5 Clock Management .....	16
1.5.1 PCI/X .....	16
1.5.2 System Clock Distribution.....	17
1.6 Other Interfaces .....	18
1.6.1 JTAG Interface.....	18
1.6.2 EEPROM Interface .....	18
1.7 Hardware Reset .....	18
1.8 Logic Analyzer Connectivity.....	18
<b>2. Configurable Options.....</b>	<b>19</b>
2.1 Switches .....	19
2.1.1 DIP Switches .....	19
2.1.2 Push Button .....	25
2.2 Shunt Jumpers .....	26
2.2.1 J1 Shunt Jumper.....	27
2.2.2 J6 Shunt Jumper.....	27
2.2.3 J21 Shunt Jumper.....	27
2.3 Debug Headers .....	28
2.3.1 J22 Tsi384 JTAG .....	29
2.3.2 J23 Logic Analyzer PADS .....	30
2.3.3 J38 CPLD JTAG.....	31
2.4 Connectors .....	32
2.4.1 J2-J36-J37 Connectors .....	32

---

2.4.2	J3 ATX Power Connector .....	33
2.4.3	P1 x4 PCIe Finger Connector .....	33
2.5	LEDs .....	34
<b>3.</b>	<b>Bill of Materials .....</b>	<b>37</b>

## About this Document

This document describes how to test the key features of the Tsi384 using the Tsi384 evaluation board. It can be used in conjunction with the Tsi384 Evaluation Board Schematics.

## Related Information

- *Tsi384 User Manual*
- *Tsi384 Evaluation Board Schematics*
- *PCI Express Base Specification (Revision 1.1)*
- *PCI Express CEM Specification (Revision 1.1)*
- *PCI Express-to-PCI/PCI-X Bridge Specification (Revision 1.0)*
- *PCI-X Addendum to PCI Local Bus Specification (Revision 1.0a)*

## Acronyms

Term	Definition
PCIe	PCI Express
PCI/X	PCI or PCI-X bus mode
SerDes	Serial/De-serializer

## Revision History

### **60E1000\_MA001\_08, Formal, September 2009**

This document was rebranded as IDT. It does not include any technical changes.

### **60E1000\_MA001\_07, Formal, May 2008**

The following changes were made to this version:

- Completed various changes in response to the Tsi384 evaluation board's removal of support for an external arbiter (see "**Arbitration**").
- Updated the document to support Revision 1.0, Assembly number E1000\_AS001\_05 of the Tsi384 evaluation board. This assembly version includes the hardware changes listed in the following table.

**Evaluation Board Changes – Assembly E1000\_AS001\_03**

Item	Previous Usage/Definition	New Usage/Definition
U11/Tsi384 Bridge	Tsi384-133CLVZ	Tsi384-133ILVZ2
PCI_LOCKn pull-up	None	Add 4.7K +/-1K size 0603 resistor between pin B39 (LOCK#) and pin B41 (3.3V) on J2
3.3Vaux on J2	No connection	Short pin A14 (3.3Vaux) to pin A21 (3.3V) by wiring
3.3Vaux on J36 and J37	No connection	Short pin A14 (3.3Vaux) to pin A21 (3.3V) by wiring
JTAG signals pull-up	2K pull-up on R288, R293, R294, R295	Change to 10K instead
PCI reset	C231 was 1uF (0603) (0603ZD105KAT2A)	Changed to 10uF (0603) MFR P/N: ECJ-1VB0J106M

**60E1000\_MA001\_06, Formal, January 2008**

Corrected the descriptions of the S7 and S8 switches. Previously, these descriptions were reversed.

**60E1000\_MA001\_05, Formal, October 2007**

Added PCI pull-up resistor values to [Table 3](#).

**60E1000\_MA001\_04, Formal, May 2007**

This document supports the Revision 1.0, Assembly number E1000\_AS001\_03 version of the Tsi384 evaluation board. This assembly version includes the hardware changes listed in the following table.

**Evaluation Board Changes – Assembly E1000\_AS001\_03**

Reference Designator	Description
<b>Removals</b>	
R13	Removed
<b>Reworks</b>	
Add 10 K Ohm pull-down to PCI_RST#	

**60E1000\_MA001\_03, Formal, April 2007**

This is the general release version of the document. There are no technical differences between this document and the previous version.

### 60E1000\_MA001\_02, Formal, March 2007

This document includes “**Bill of Materials**” for the Tsi384 evaluation board. It supports the Revision 1.0, Assembly number E1000\_AS001\_02 version of the Tsi384 evaluation board. This assembly version includes the hardware changes listed in the following table.

#### Evaluation Board Changes – Assembly E1000\_AS001\_02

Reference Designator	Description
<b>Changes</b>	
R88	Change to .015ohm
R242,R272,R6	Change to 1Kohm
C182,C183,C193, C189,C207,C202	Change to 2.2uF
R148	Populate
R150	Populate
C77,C45	Install
C235	Change to 300nF
R208	130 Ohm
R215	220 Ohm
R220	441 Ohm
R139	2260 Ohm
R144	220 Ohm
R196	441 Ohm
<b>Removals</b>	
R141	Remove
<b>Reworks</b>	
Add 1kohm resistor pull-up to LOCK#	

### 60E1000\_MA001\_01, Formal, March 2007

This is the first version of the *Tsi384 Evaluation Board User Manual*. This document supports the Revision 1.0, Assembly number E1000\_AS001\_01 version of the Tsi384 evaluation board.



---

# 1. Board Design

Topics discussed include the following:

- “Overview” on page 9
- “PCI/X Interface” on page 10
- “PCIe Interface” on page 12
- “Power Management” on page 13
- “Clock Management” on page 16
- “Other Interfaces” on page 18
- “Hardware Reset” on page 18
- “Logic Analyzer Connectivity” on page 18

---

## 1.1 Overview

The key features of the Tsi384 evaluation board include the following:

- Single x4 lane, 2.5 Gbps PCIe 1.1 compatible riser card (extended height form factor)
- Three PCI/X slots
- 32-/64-bit PCI/X bus, 25–133 MHz operation
- PCI/X power support through system or external supply
- PCIe compliance/debugging test points

Figure 1: Evaluation Board Block Diagram

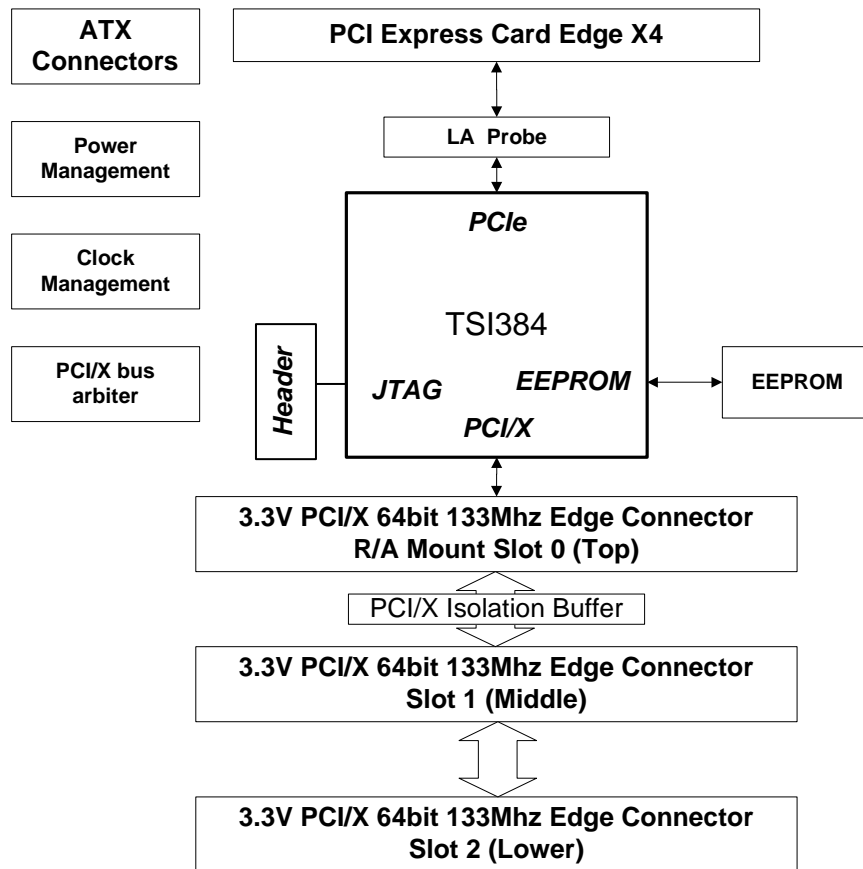

## 1.2 PCI/X Interface

### 1.2.1 Overview

The PCI/X Interface is implemented on the board with three slots, in which one is an R/A mounted connector on the top of the board. All PCI/X connectors are compliant with the PCI/X 2.0b specification. Appropriate clearance is provided such that up to three PCI/X cards can be inserted for testing while the board is in an open-chassis standard ATX case.

The PCI/X Interface supports the configurations listed in [Table 1](#).

**Table 1: PCI/X Interface — Supported Configurations**

Protocol	Operating Speed (MHz)	Number of Slots Supported
PCI	25, 33, 50, 66	3
PCI-X	50, 66	3
PCI-X	100	2
PCI-X	133	1

The support for PCI-X 133 MHz operation is possible with the use of an isolation buffer. The R/A connector located on the top of board is available in this maximum frequency. The PCI bus is routed forward and returned to the other slots to expand the bus for multi-slot support.

### 1.2.2 IDSEL Signals

IDSEL signals are connected in the following order:

- Slot 0 – R/A connector top slot: 2K ohms to AD16 (Device 0)
- Slot 1 – Vertical middle slot: 2K ohms to AD19 (Device 3)
- Slot 2 – Vertical lower slot: 2K ohms to AD18 (Device 2)

The 2K ohm resistor value is consistent with the ability of the Tsi384 to drive the AD lines 2 clock cycles prior in PCI mode, and 4 clock cycles prior in PCI-X mode. The PCI/X Interface is unterminated with the exception of the clock signals.

### 1.2.3 Interrupt Signals

The PCI interrupt signals are connected to the slots as shown in [Table 2](#).

**Table 2: PCI Interrupt Routing**

Tsi384	Slot 0	Slot 1	Slot 2
A	A	D	C
B	B	A	D
C	C	B	A
D	D	C	B

### 1.2.4 PCI Pull-up Signals

The following signals have a pull-up resistor on the PCI bus.

**Table 3: PCI Pull-up Signals**

Signal	Description	Resistor Value
PCI_CBE#[4:7]	Byte enables for upper 32-bit AD lines	8.2K
PCI_REQ#[0:3]	Bus request	8.2K
PCI_GNT#[0:3]	Bus grant	8.2K
PCI_FRAME#	Control signal	8.2K
PCI_IRDY#, PCI_TRDY#	Control signal	8.2K
PCI_STOP#	Control signal	8.2K
PCI_SERR#	System error	8.2K
PCI_PERR#	Parity error	8.2K
PCI_PAR	Parity of lower 32-bit lines and CBE bus	8.2K
PCI_PAR64	Parity of upper 32-bit AD lines and CBE bus	8.2K
PCI_DEVSEL#	Device select line	8.2K
PCI_INT#[A:D]	Interrupt line	2.4K
PCI_PME#	PCI Power Management Event occurred	8.2K

### 1.2.5 Arbitration

The Tsi384 evaluation board has provisions to implement an external arbiter; however, the current PCB assembly does not have the external arbiter implemented. Therefore, the only valid mode of operation is internal arbiter enabled.

## 1.3 PCIe Interface

The Tsi384 evaluation board implements a four-line PCIe interface. It is designed to connect onto a PCIe system with a standard x4 finger connector. The system must provide the REFCLK and PERSTN signals. The PCIe interface has the following design elements:

- Supports Hot insertion and removal
- Mid-bus logic analyzer pads for PCIe RXD/TXD signal probing
- AC coupling on the TXD lanes
- JTAG TDI - TDO loopback for chain continuity

## 1.4 Power Management

### 1.4.1 Power Regulation

The evaluation board’s power regulation is implemented as follows:

- Digital 3.3V power supply available from DC/DC regulator or ATX supply
- Digital 1.2V switching regulator
- PCIe supplies filtered using EMI ferrite networks

To support PCI/X cards, the following additional power resources are included:

- 12V to 5V DC/DC converter
- 12V to 3.3V DC/DC converter
- External power connectors – ATX 20-pin connector for supplying all power from an ATX power supply

### 1.4.2 Power Requirements

The power requirements and implementation for the Tsi384 is as follows.

**Table 4: Tsi384 Power Requirements**

Supply Name	Symbol	Supplied Source
Device Core	1.2V_384	DC/DC switching regulator w/Enable pin
PCIe 1.2V Core	1.2V_A_384	Passive Filter
PCI 3.3v supply	3.3V_384	Power switch w optional Ferrite filter to reduce EMI/noise from PCI environment
PCIe 3.3v supply	3.3V_A_384	Passive Filter

The target power draw of the Tsi384 is a maximum of 2 Watts, all supplies combined. The supplies to the Tsi384 are controlled during ramp up using enable pins on regulators and switches.

#### 1.4.2.1 PCIe

The PCIe CEM Specification 1.1 defines power limits on PCIe slots according to the number of lanes available on the card. Power rules regarding x4 PCIe slots are a maximum of 25W slot. Current limits are included in [Table 5](#).

**Table 5: PCIe Connector Current Limits**

Rail	Current
3.3V	3A
12V	2.1A

In both cases (x4 or x16), the usage of the 12V supply provides access to the full 25W/75W available from the system to the board. The PCIe pinout design includes more 12V power pins as it allows more power-per-pin capability. The evaluation board regulates all power from the 12V system rail; however, 3.3V from the system remains unused.

**1.4.2.2 PCI/X**

The PCISIG defines the power rules regarding PCI/X cards as a maximum of 25 Watts per card (All power rails combined power draw). The individual current limits on voltage rails are included in [Table 6](#).

**Table 6: PCI/X Connector current limits**

Rail	Current
3.3v	7.6a
5v	5a
-12v	100ma
12v	500ma

It is not possible “within spec” to provide the full power required to the PCI/X without violating the specification while drawing power from only a x4 PCIe system. Up to 23W not including regulator efficiency losses can be made available. The evaluation board provides the power requirements in one of two ways depending on the application:

- PCIe system power
- ATX System connector

The following conditions summarize the power available for a single PCI/X card without external supply. An efficiency of 85% is taken into account for switching regulators. These limits can be exceeded in cases where the system can provide more than the suggested limit, which is usually only implemented in hot swap systems.

**Table 7: PCI/X Connector Current Limit with No External Supply**

Rail	Supplying Topology	Current (Maximum)
3.3V	12V to 3.3V regulator	6A
12V	12V directly	500mA
-12V	N/A	N/A
5V	12V to 5V regulator	4A

For additional slots, or in cases where the system cannot supply enough power, a separate ATX power connector is used to power the card. The evaluation board senses the presence of this supply, and disables the slave PCIe slot power. For the case of a separate external ATX supply, all three slots are provided with the required power.

### 1.4.3 Power Sequencing

On power-up, the card power sequencing is as follows:

1. 1.2V powered on
2. PCI/X I/O slot power and pull-ups, and Tsi384 3.3V

12V/-12V/5V PCI are not sequence controlled.

### 1.4.4 System Power Design

Figure 2 illustrates the power distribution for the riser card. The following list is a functional summary of the power design:

1. Sequencing control over the following rails:
  - 3.3V PCI
  - 3.3V Tsi384 I/O/PCIe  $A_{VDD}$
  - 1.2V Tsi384 Core/PCIe  $V_{DD}$
2. ATX 20-pin connector override, which disables all power draw from the PCIe system
3. Current sensing of Tsi384 supplies

Figure 2: System Power Distribution

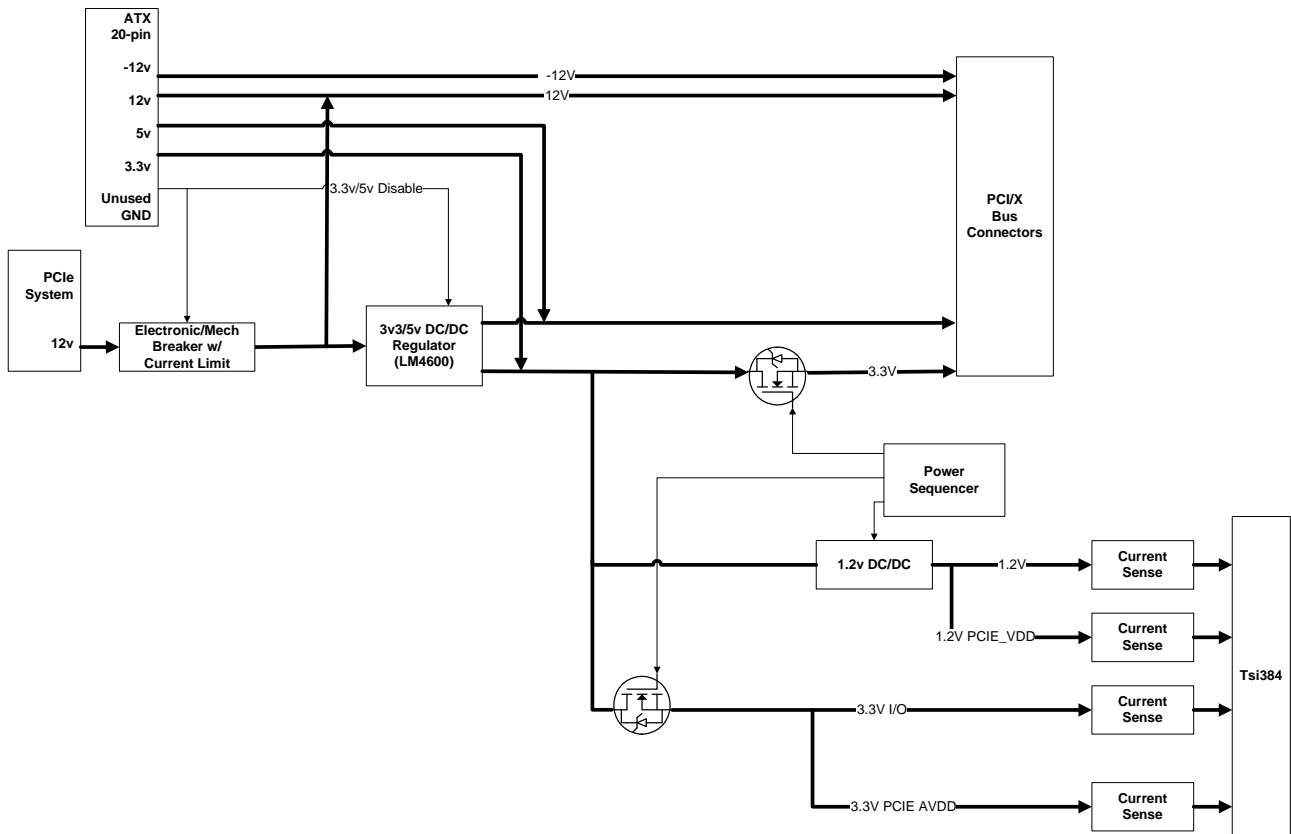

## 1.5 Clock Management

The Tsi384 requires up to two input clocks to operate:

- 25–133MHz clock for PCI/X
- 100-MHz reference clock for PCIe

The PCI/X and PCIe input clocks are briefly discussed.

### 1.5.1 PCI/X

The evaluation board supports master and slave clocking for PCI/X.

- Master – When in master mode, the Tsi384 generates the required PCI/X clock for all slots.
- Slave – When in slave mode, an on-board selectable 25–133 MHz clock generator is used as follows:

- Low skew distribution buffer to all slots and Tsi384
- External clock input for any optional testing



To multiplex the sources of two clocks, passive resistor muxes are located at the endpoints of the clock nets. For more information, see the *Tsi384 Evaluation Board Schematic (60E1000\_SC002)*.

### 1.5.1.1 PCIe

For PCIe clocking, a 100-MHz differential HCSL clock source is required. The clock source is available in two forms:

- Edge connector clock source – This clock source synchronizes the system SerDes with the Tsi384.
- On-board 100-MHz reference – This clock source can separate the clock domains between the bridge and the root complex.

The two PCIe clock sources are multiplexed with an analog multiplexer to select between the system clock or on-board clock (see [Figure 3](#)).

### 1.5.2 System Clock Distribution

[Figure 3](#) shows the distribution of the system clock on the Tsi384 evaluation board.

**Figure 3: System Clock Distribution**

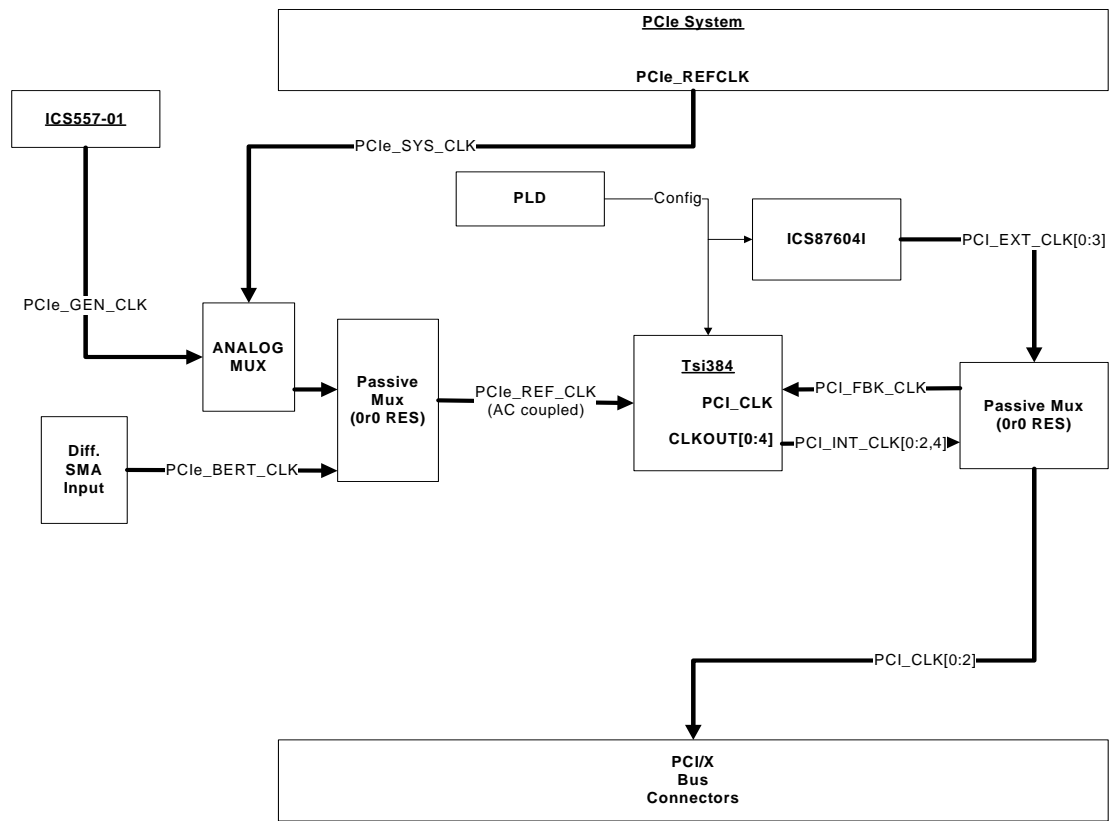

## 1.6 Other Interfaces

### 1.6.1 JTAG Interface

To support debug and testing of device, JTAG access to the Tsi384 is available using a standard JTAG header for Wiggler connection.

### 1.6.2 EEPROM Interface

A single EEPROM device socket is available for programming registers during startup. The socket is in an 8-pin DIP format.

## 1.7 Hardware Reset

Figure 4 illustrates the reset options of the Tsi384 evaluation board.

Figure 4: Board Reset

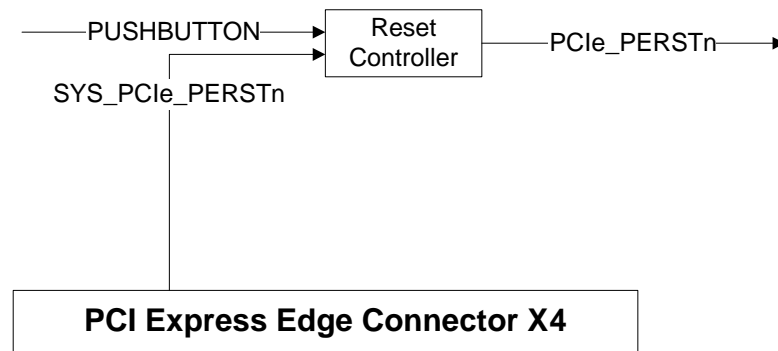

Three levels of reset are available:

- Cold reset – This reset is applied during power up. System (card edge) PCIe\_PERSTn is muxed with the board’s reset controller.
- Warm reset – This reset is activated by a push-button reset on the board.
- Hot reset – This reset is activated by the in-band message sent by the root complex. No supporting hardware is necessary.



For more information on cold, warm, and hot reset levels, see the “Resets, Clocking, and Initialization Options” chapter in the *Tsi384 User Manual*.

## 1.8 Logic Analyzer Connectivity

The serial buses have Midbus pads (TMS818 probe) for visibility of SerDes lines using a pre-processor. Each probing pad provides access to the RX and TX segments of a x4 link.

To access the PCI/X bus, a Nexus PCI/X interposer card can be used with Tektronix mictor cables. The card can be plugged into any PCI edge slot, or in-line with the device under test.

## 2. Configurable Options

Topics discussed include the following:

- “Switches” on page 19
- “Shunt Jumpers” on page 26
- “Debug Headers” on page 28
- “Connectors” on page 32
- “LEDs” on page 34

### 2.1 Switches

#### 2.1.1 DIP Switches

Switches S1 to S6 combine four, small slide switches identified with numbers 1 to 4 (see [Table 8](#) for individual switch definition).

**Figure 5: DIP Switch Package/Individual Switch Position**

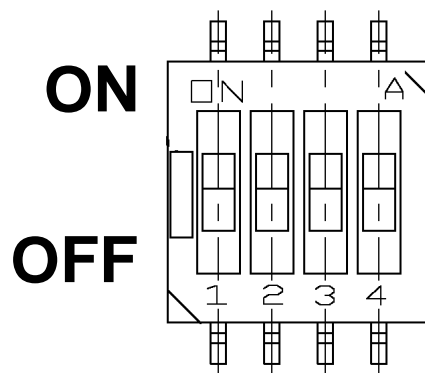
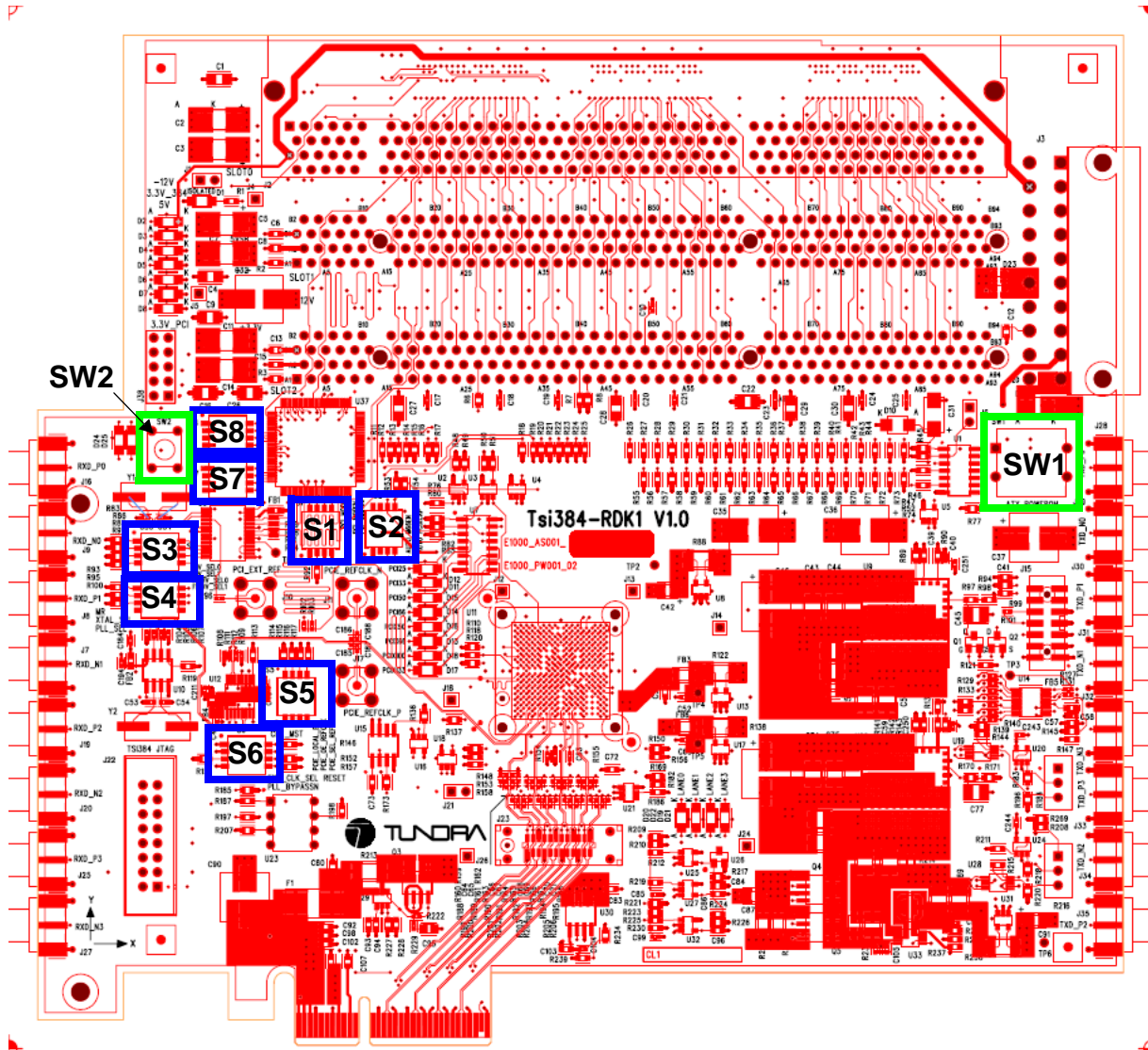

Figure 6: Switch Locations



Switch S1 is used to manually set PCI/X bus modes.

**Table 8: S1 Settings**

Switch Number	Description	Default Setting	On/Off Setting
1	PCIXCAP setting	OFF	ON = Forces Tsi384's PCIXCAP input to ground OFF = Tsi384's PCIXCAP input has a weak pull up to 3.3V
2	PCIXCAP setting	OFF	ON = Tsi384's PCIXCAP input has a weak pull down to ground OFF = Tsi384's PCIXCAP input has a weak pull up to 3.3V
3	M66EN setting	OFF	ON = Forces Tsi384's M66EN input to ground OFF = Tsi384's M66EN input has a weak pull up to 3.3V
4	PCI_SEL100 setting	ON	ON = Forces Tsi384's PCI_SEL100 input to ground OFF = Tsi384's PCI_SEL100 input has a weak pull up to 3.3V

**Table 9: Bus Mode Setting for S1 (Assumes S2.3 and S2.4 are OFF)**

Switch Setting (Switch 1 - 2 - 3 - 4)	Signal Setting	Bus Mode
OFF - OFF - x - OFF	PCIXCAP = High M666EN = x PCI_SEL100 = High	PCIX 100 MHz
OFF - OFF - x - ON	PCIXCAP = High M666EN = x PCI_SEL100 = Low	PCIX 133 MHz
OFF - ON - x - OFF	PCIXCAP = pull-down M666EN = x PCI_SEL100 = High	PCIX 50 MHz
OFF - ON - x - ON	PCIXCAP = pull-down M666EN = x PCI_SEL100 = Low	PCIX 66 MHz
ON - x - OFF - OFF	PCIXCAP = Low M666EN = High PCI_SEL100 = High	PCI 50 MHz
ON - x - OFF - ON	PCIXCAP = Low M666EN = High PCI_SEL100 = Low	PCI 66 MHz

**Table 9: Bus Mode Setting for S1 (Assumes S2.3 and S2.4 are OFF) (Continued)**

Switch Setting (Switch 1 - 2 - 3 - 4)	Signal Setting	Bus Mode
ON - x - ON - OFF	PCIXCAP = Low M666EN = Low PCI_SEL100 = High	PCI 25 MHz
ON - x - ON - ON	PCIXCAP = Low M666EN = Low PCI_SEL100 = Low	PCI 33 MHz

Switch S2 is used to connect PCI bus mode signal to the Tsi384.

**Table 10: S2 Settings**

Switch Number	Description	Default Setting	On/Off Setting
1	No function	-	-
2	No function	-	-
3	Bus M66EN connection	ON	ON = Connect the PCI M66EN signal to the Tsi384 OFF = Disconnect the PCI M66EN from the Tsi384
4	Bus PCIXCAP connection	ON	ON = Connect the PCI PCIXCAP signal to the Tsi384 OFF = Disconnect the PCI PCIXCAP from the Tsi384

Note that S1 and S2 operate together. When the S2 switches are ON, the S1 setting applies to the whole bus. For example, when PCIXCAP is connected to the Tsi384 (S2.4 ON), and PCIXCAP is forced to ground (S1.1 ON), the whole bus will see PCIXCAP low.

Switches S3 and S4 are used to set the PCI/X bus external clock frequency. By default the PCI/X bus clock source is the Tsi384. The external clock can only be connected to the PCI/X bus by replacing resistors on the board. When an external clock source is used, an on-board PLL is used to set the proper bus clock frequency. Table 11 contains the clock frequency settings for S3.

**Table 11: S3 Settings**

Switch Number	Description	Default Setting	On/Off Setting
1	DIV_SEL0	OFF	[FBDIV_SEL1, FBDIV_SEL0, DIV_SEL1, DIV_SEL0]
2	DIV_SEL1	OFF	ON = 1 OFF = 0
3	FBDIV_SEL0	OFF	0,0,0,0 = x 4 0,0,0,1 = x 3
4	FBDIV_SEL1	OFF	0,0,1,0 = x 2 0,0,1,1 = x 1 0,1,0,0 = x 5.33 0,1,0,1 = x 4 0,1,1,0 = x 2.667 0,1,1,1 = x 1.33 1,0,0,0 = x 6.667 1,0,0,1 = x 5 1,0,1,0 = x 3.33 1,0,1,1 = x 1.67 1,1,0,0 = x 8 1,1,0,1 = x 6 1,1,1,0 = x 4 1,1,1,1 = x 2

Switch S4 controls the external clock PLL.

**Table 12: S4 Settings**

Switch Number	Description	Default Setting	On/Off Setting
1	PLL Reset	ON	ON = PLL in reset. PLL clock outputs are low. OFF = PLL is active and clock outputs are enabled.
2	XTAL select	OFF	ON = Clock source for PLL is reference clock from connector J10 OFF = Clock source for PLL is a 25-MHz oscillator.
3	PLL select	OFF	ON = PLL is bypassed. OFF = PLL is enabled. External clock source is multiplied as per S3 setting
4	No function	-	-

Switch S5 controls the PCIe clock multiplexer and the on-board PCIe reference clock PLL.

**Table 13: S5 Settings**

Switch Number	Description	Default Setting	On/Off Setting
1	No Function	-	-
2	PCIe on-board PLL enable	ON	ON = On-board PCIe reference clock PLL disabled. OFF = On-board PCIe reference clock PLL enabled.
3	PCIe clock multiplexer enable	OFF	ON = On-board PCIe clock multiplexer disabled. OFF = On-board PCIe clock multiplexer enabled.
4	PCIe clock source select	OFF	ON = On-board PCIe reference clock is used. OFF = System PCIe reference clock is used.

Switch S6 configures Tsi384's power-up options.

**Table 14: S6 Settings**

Switch Number	Description	Default Setting	On/Off Setting
1	Clock Master option	OFF	ON = Tsi384 is clock slave on the PCI/X bus OFF = Tsi384 is clock master on the PCI/X bus (clock master mode)
2	Internal arbiter option	OFF	ON = Internal arbiter is disabled OFF = Internal arbiter is enabled
3	PCI-X clock selection	ON	ON = When in clock master mode, the Tsi384 uses the clock on PCI_CLK compensated through the PLL to time the PCI-X Interface. OFF = When in clock master mode, the Tsi384 uses the internal clock generated from REFCLK to time the PCI-X Interface.
4	PCI-X PLL bypass	OFF	ON = PLL is bypassed. OFF = PLL is enabled.

These switches are not used.

**Table 15: S7 and S8 Settings**

Switch Number	Description	Default Setting	On/Off Setting
1	No function	-	-
2	No function	-	-
3	No function	-	-
4	No function	-	-

### 2.1.2 Push Button

SW1 is used to turn the ATX power supply ON. This switch is used only when the evaluation board is powered up with a stand-alone ATX power supply.

SW2 is used to reset the evaluation board. When pushing the reset button, the board is reset the same way a PCIe system reset would reset the board.

## 2.2 Shunt Jumpers

Shunt jumpers are used to control special features on the board (see Figure 7). These jumpers are explained in the following sub-sections.

Figure 7: Shunt Jumper Location

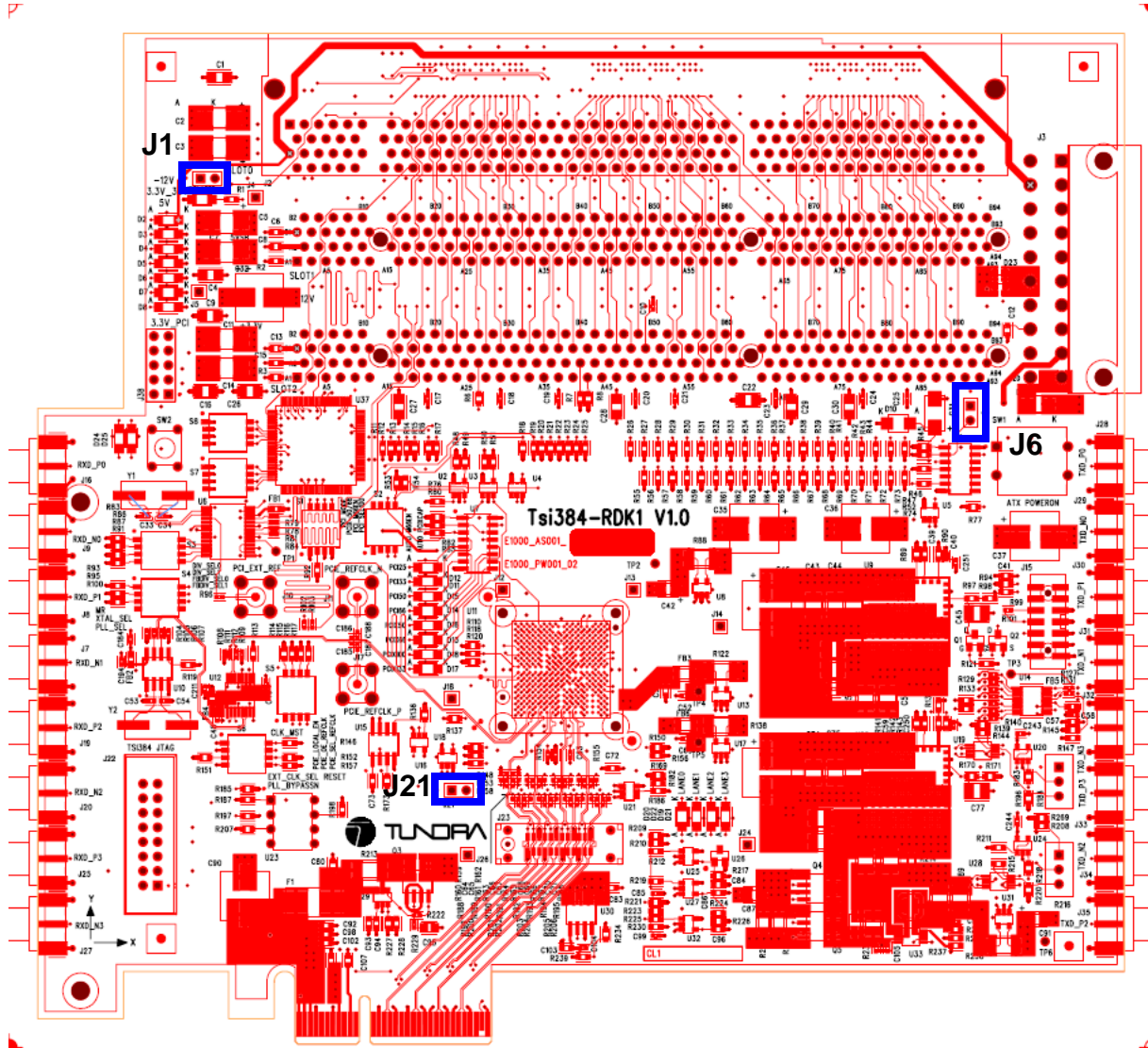

### 2.2.1 J1 Shunt Jumper

J1 is used to enable the isolation switches on the PCI/X bus. The switches are located between slot 0 and slot 1. The switches are used isolate slot 1 and 2 from the PCI bus in order to reduce loading on slot 0. This allows PCI bus operation at 133 MHz with reduced bus loading.

**Table 16: J1 Shunt Jumper Setting**

Jumper Setting	Default Setting	Function
Installed	Installed	PCI bus Isolation switches are ON. All 3 slots are operational.
Removed		PCI bus Isolation switches are OFF. Slot 0 is functional, slot 1 and 2 are isolated.

### 2.2.2 J6 Shunt Jumper

J6 is used to bypass the On/Off push button to enable the ATX power supply.

**Table 17: J6 Shunt Jumper Setting**

Jumper Setting	Default Setting	Function
Installed	Removed	Forces ATX power supply ON.
Removed		Normal operation, ATX power supply is turned On/OFF from push button.

### 2.2.3 J21 Shunt Jumper

J21 is used to force the Tsi384 into a special debug mode. This jumper is not installed.

### 2.3 Debug Headers

Debug headers are used to connect to signals on the board. This section provides header pinouts.

Figure 8: Debug Header Location

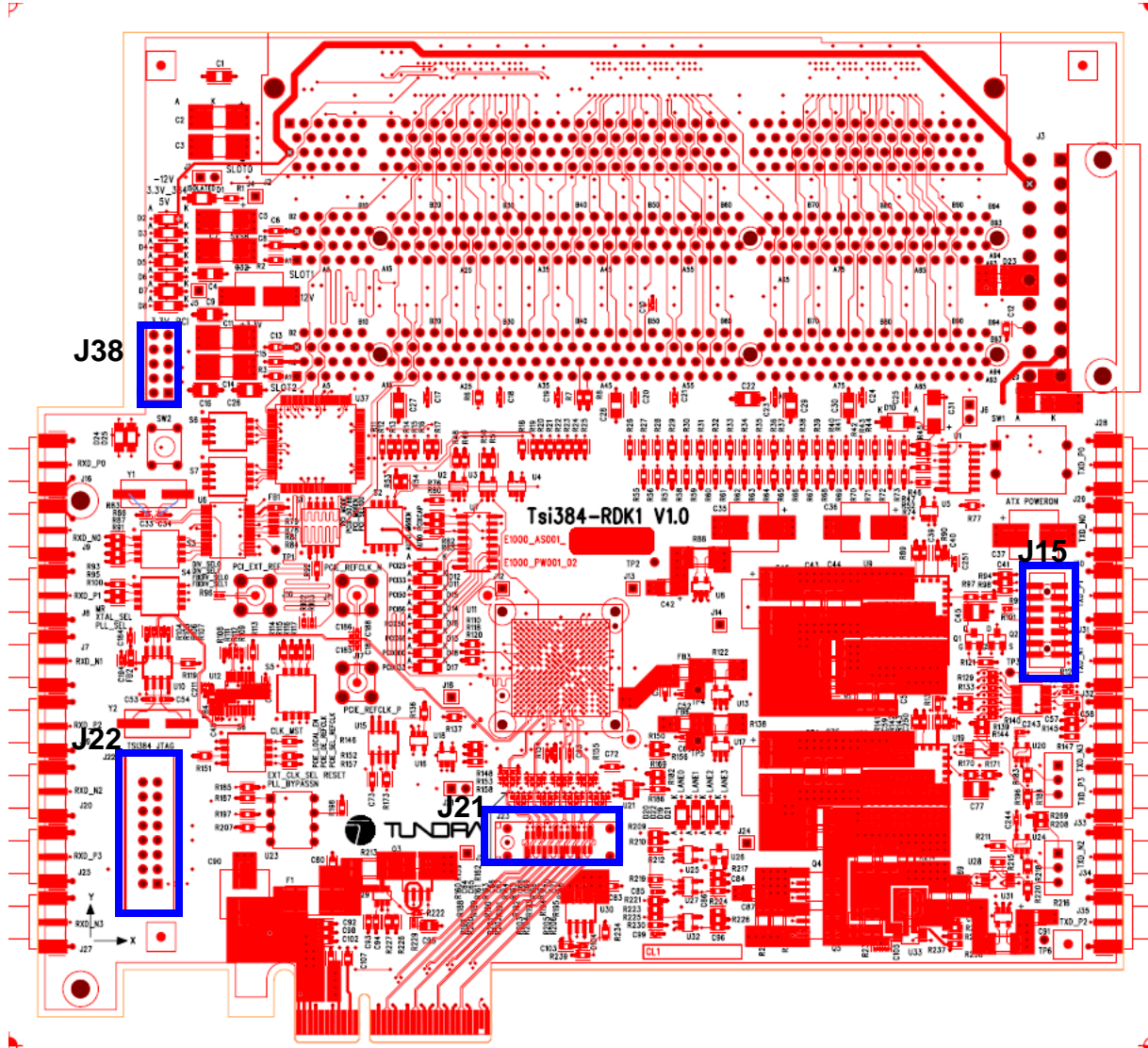

### 2.3.1 J22 Tsi384 JTAG

Table 18: J22 Pin Assignment

Pin Number	Signal Assignment	J22 Pin Location
1	TDO	<p style="text-align: center;"><b>J22</b>      <b>TSI384 JTAG</b></p>
2	NC	
3	TDI	
4	3.3V	
5	NC	
6	3.3V	
7	TCK	
8	NC	
9	TMS	
10	NC	
11	NC	
12	GND	
13	NC	
14	NC	
15	NC	
16	GND	

### 2.3.2 J23 Logic Analyzer PADS

Table 19: J23 Pin Assignment

Pin Number	Signal Assignment	J23 Pin Location
1	PCIE_TXD_EDG_P0	
2	GND	
3	PCIE_TXD_EDG_N0	
4	PCIE_RXD_EDG_P0	
5	GND	
6	PCIE_RXD_EDG_N0	
7	PCIE_TXD_EDG_P1	
8	GND	
9	PCIE_TXD_EDG_N1	
10	PCIE_RXD_EDG_P1	
11	GND	
12	PCIE_RXD_EDG_N1	
13	PCIE_TXD_EDG_P2	
14	GND	
15	PCIE_TXD_EDG_N2	
16	PCIE_RXD_EDG_P2	
17	GND	
18	PCIE_RXD_EDG_N2	
19	PCIE_TXD_EDG_P3	
20	GND	
21	PCIE_TXD_EDG_N3	
22	PCIE_RXD_EDG_P3	
23	GND	
24	PCIE_RXD_EDG_N3	

### 2.3.3 J38 CPLD JTAG

Table 20: J38 Pin Assignment

Pin#	Signal Assignment	J38 Pin Location
1	TCK	
2	GND	
3	TDO	
4	3.3V	
5	TMS	
6	NC	
7	NC	
8	NC	
9	TDI	
10	GND	

## 2.4 Connectors

Figure 9: Board Connector Location

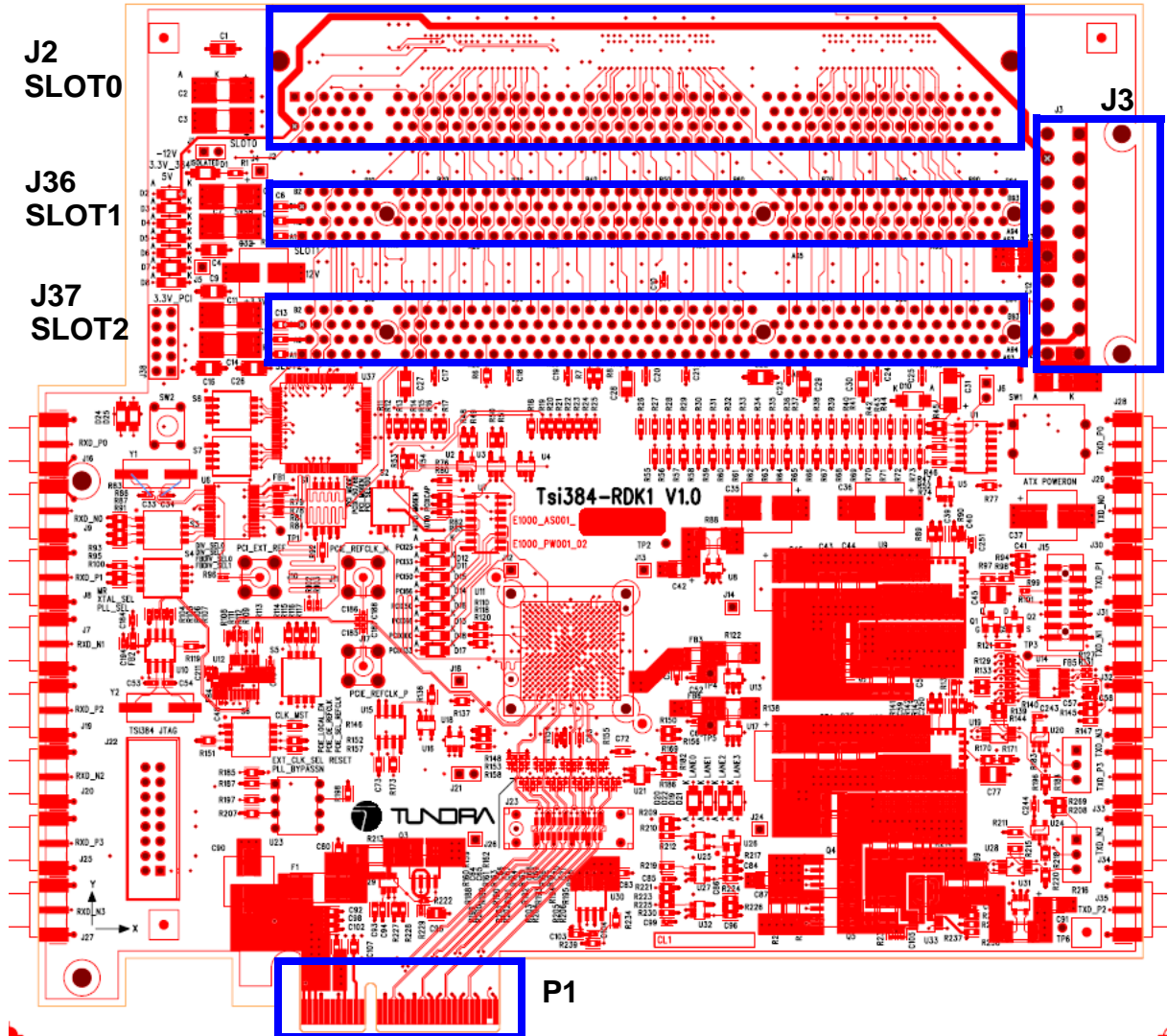

### 2.4.1 J2-J36-J37 Connectors

J2, J36, and J37 are used to connect a plug-in card to the Tsi384's PCI/X Interface. The connectors' pin assignments is as per the PCI standard for 64-bit connectors

### 2.4.2 J3 ATX Power Connector

A standard ATX power supply can be used to power up the board when used stand alone (not plugged into a PCIe system).

**Table 21: J3 Pin Assignment**

Pin Number	Signal Assignment	J3 Pin Location
1	3.3V	
2	3.3V	
3	GND	
4	5V	
5	GND	
6	5V	
7	GND	
8	N.C.	
9	5VSB	
10	12V	
11	3.3V	
12	-12V	
13	GND	
14	GND	
15	GND	
16	GND	
17	GND	
18	N.C.	
19	5V	
20	5V	

### 2.4.3 P1 x4 PCIe Finger Connector

The pin assignment for the finger connector is as per the PCIe standard. Note that the JTAG signals TDI and TDO are connected together on the board.

## 2.5 LEDs

Figure 10: LED Location

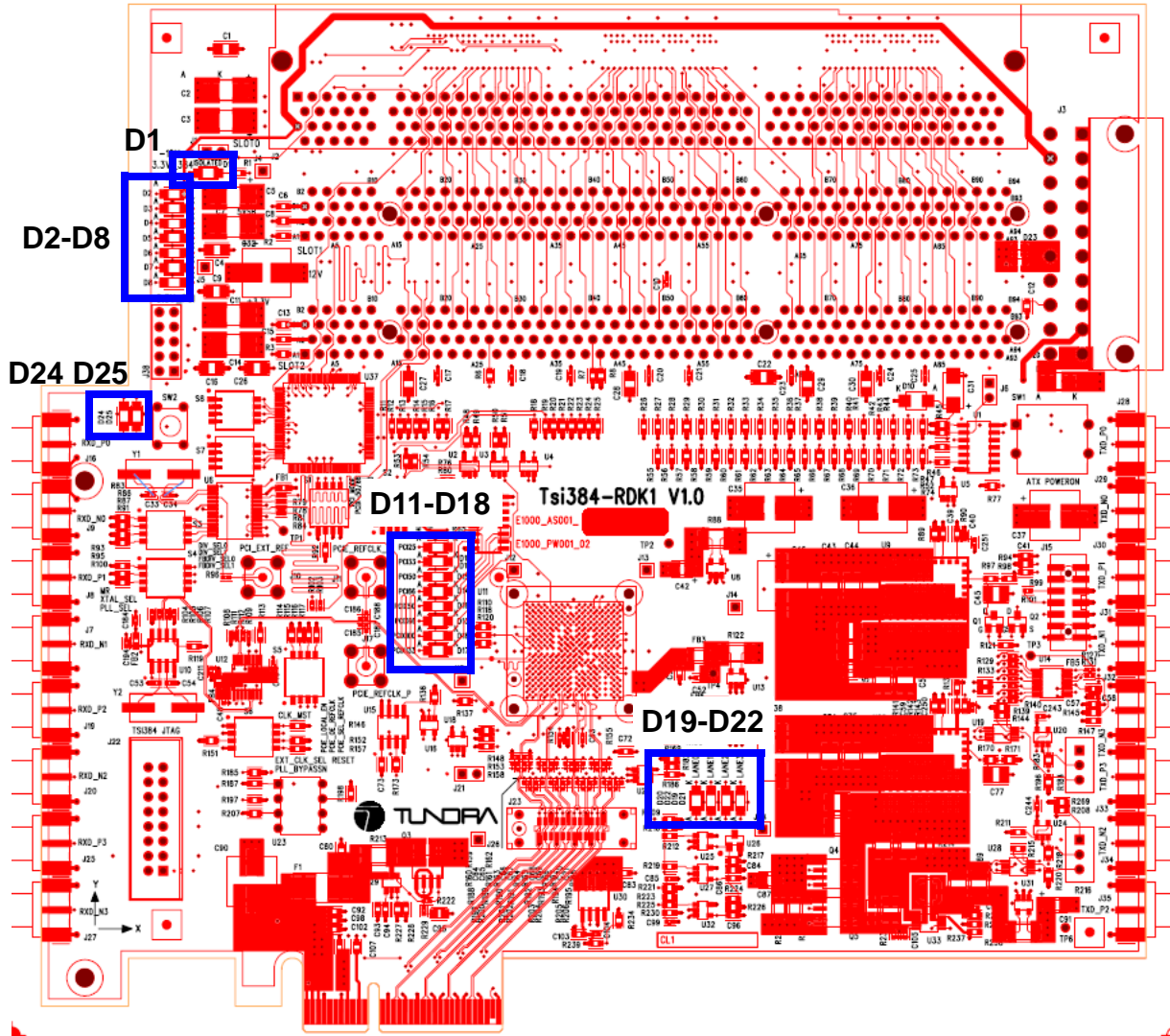

**Table 22: LED Description**

LED Designation	Signal Assignment	Description
D1	BUFSLOT_LED	OFF when PCI slots 1 and 2 are isolated from the bus
D11	PCI33	PCI bus at 33 MHz
D12	PCI25	PCI bus at 25 MHz
D13	PCIX66	PCI-X bus at 66 MHz
D14	PCI66	PCI bus at 66 MHz
D15	PCI50	PCI bus at 50 MHz
D16	PCIX50	PCI-X bus at 50 MHz
D17	PCIX133	PCI-X bus at 133 MHz
D18	PCIX100	PCI-X bus at 100 MHz
D19	PCIe lane 2 valid	Valid PCIe connection on lane 2
D2	-12V	ON when -12V rail is active
D20	PCIe lane 0 valid	Valid PCIe connection on lane 0
D21	PCIe lane 3 valid	Valid PCIe connection on lane 3
D22	PCIe lane 1 valid	Valid PCIe connection on lane 1
D3	3.3V_384	ON when Tsi384 3.3V rail is active
D4	5V	ON when 5V rail is active
D5	5VSB	ON when 5V standby rail is active
D6	3.3V	ON when 3.3V rail is active
D7	12V	ON when 12V rail is active
D8	3.3V_PCI	ON when 3.3V rail on the PCI bus is active
D24	External arbiter	ON when external PCI/X arbiter is active
D25	External arbiter	ON when in PCI/X mode



### 3. Bill of Materials

The bill of materials (BOM) for the Tsi384 evaluation board is listed in the following table.

**Table 23: Bill of Materials**

Quantity	Reference Designator	Part Number	Manufacturer	Package Type	Description
1	AP_U1	115-13-308-41-001	MILL-MAX	115-13-308-41-001	DUAL-IN-LINE SOCKET, 0.1IN, 8PIN
12	C1,C4,C9, C16, C22, C26-30, C143,C165	1206ZD106KAT2A	AVX	CAPC1206	X5R CER SMT, 10UF, 10%, 10V, 1206
7	C2-3,C5,C7,C11, C14,C31	TAJC476K016R	AVX	CAPT6032-28	TANT SMT, 47UF, 10%, 16V, 6032-28
26	C6, C8, C12-13, C15, C39, C59, C73, C80, C92-94, C96,C98, C102, C106-107, C128-129, C172-173, C177, C234, C240-242	06033D104KAT2A	AVX	CAPC0603	X5R CER SMT, 0.1UF, 10%, 25V, 0603
5	C10, C62, C140, C162, C175	0402ZC103KAT2A	AVX	CAPC0402	X7R CER SMT, 0.01UF, 10%, 10V, 0402
113	C17-21, C23-25, C38, C48-49, C52, C60-61, C64-71, C105, C108-127, C130-139, C141-142, C144-161, C163-164, C166-171, C176,C179, C184-186, C190,C192, C194-196, C198, C200-201, C203, C206, C211-212, C217-218, C220-223, C226-228, C233, C245-249	0402ZD104KAT2A	AVX	CAPC0402	X5R CER SMT, 0.1UF, 10%, 10V, 0402
7	C32, C35-37, C46,C76, C90	EEVFC1E101P	PANASONIC	CAPAE95W62H	ALUM ELEC SMT, 100UF, 20%, 25V
4	C33-34, C53-54	04025A180JAT2A	AVX	CAPC0402	NP0 CER SMT, 18PF, 5%, 16V, 0402
4	C42,C87, C91,C100	TAJA106K016R	AVX	CAPT3216-18	TANT SMT, 10UF, 10%, 16V, 3216-18
6	C43-44, C74-75, C89, C101	ECJ-4YB1E226M	PANASONIC	CAPC1210	X5R CER SMT, 22UF, 20%, 25V, 1210
2	C45,C77	12103C105KAT2A	AVX	CAPC1210	X7R CER SMT, 0.22UF, 10%, 50V, CAPC1210
8	C47,C51, C55-56, C78-79, C81-82	12106D107MAT2A	AVX	CAPC1210	X5R CER SMT, 100UF, 20%, 6.3V, 1210
6	C50,C178, C197,C199, C225,C231	0603ZD105KAT2A	AVX	CAPC0603	X5R CER SMT, 1UF, 10%, 10V, 0603
2	C85,C99	ECJ-0EB1C104K	PANASONIC	CAPC0402	X5R CER SMT, 100NF, 10%, 16V, CAPC0402

**Table 23: Bill of Materials (Continued)**

Quantity	Reference Designator	Part Number	Manufacturer	Package Type	Description
1	C95	ECJ-2VB1H103K	PANASONIC	CAPC0805	X7R CER SMT, 10NF, 10%, 50V, 0805 CAPC0805
1	C97	0402ZC103JAT2A	AVX	CAPC0402	X7R CER SMT, 0.01UF, 5%, 10V, 0402
1	C174	ECJ-1VB0J106M	PANASONIC	CAPC0603	X5R CER SMT, 10UF, 20%, 6.3V, 0603
1	C181	ECJ-1VB0J106M	PANASONIC	CAPC0603	X5R CER SMT, 10UF, 20%, 6.3V, 0603
7	C182-183, C189,C191, C193,C202, C207		MURATA	CAPC0402	X5R CER SMT, 2.2UF, 20% 6.3V CAPC0402
2	C250-251	0402YC101KAT2A	AVX	CAPC0402	X7R CER SMT, 100PF, 10%, 16V, 0402
20	D1-8, D11-22	HSMG-C150	AGILENT	LED_HSMG-C150	GREEN LED, UNTINTED, DIFFUSED
1	D9		DIODES INC.	DIOSMA	2A SCHOTTKY DIODE RECTIFIER 0.5VF
1	D10	S1B	FAIRCHILD	DIOSMA	GENERAL PURPOSE RECTIFIER
1	D23	LCDA15C-1.TC	SEMTECH	SOT143	TVSDIODEARRAY
2	D24-25	HSMG-C150	AGILENT	LED_HSMG-C150	GREEN LED, UNTINTED, DIFFUSED
1	F1	R154 010	LITTLEFUSE	FUSE_154	SMT FUSE BLOCK FOR FAST 10AFUSE (INCLUDED)
4	FB1-2,FB4, FB7	BLM18AG601SN1 D	MURATA	FB_0603	SMT FERRITE BEAD, 60OHMS, 25%, 0.2AMPS, 0603
2	FB3,FB6	BLM31PG500SN1 B	MURATA	FB_1206	SMT FERRITE BEAD, 50OHMS, 25%, 3AMPS, 1206
2	J1,J6	69190-102	FCI	69190-102H	2X1,0.1INHDR
1	J2		MERITEC	981131-184-2MPF	64-BIT PCI/X CONNECTOR 3.3V R/A W/CLIPS, 0.1MIL
1	J3	39-30-0200	MOLEX	39-30-0200	R/A ATX PWR JACK, 0.165" PITCH, MINIFIT W/PEGS
1	J21	69190-102	FCI	69190-102H	2X1,0.1INHDR
1	J22	5103309-3	TYCO	5103309-3	2X8, 0.1IN HDR,CENTER/DUAL POLARIZINGBARSHROUD
2	J36-37	145165-4	AMP	145165-4	PCI MOTHERBOARD, 64BIT, 3.3V, THRU
1	J38	67997-110	FCI	67997-110H	2X5,0.1INHDR
1	L1		COILCRAFT	LPS4018	2.2UH SMT POWER INDUCTOR, 2.5A ISAT, .070ESR
1	P1	X4PCIE_FINGER_CONNECTOR	IDT	X4PCIE_FINGER_CONNECTOR	PCIEX4FINGERCONNECTOR

**Table 23: Bill of Materials (Continued)**

Quantity	Reference Designator	Part Number	Manufacturer	Package Type	Description
2	Q1-2	2N7002	FAIRCHILD	SOT23-3-GSD	N-CHANNELMOSFET
1	Q3	FDS6990A	FAIRCHILD	SOIC127P6-8	2N-CHMOSFET30V7.5A
2	Q4-5	IRF8915	INTERNATIONAL RECTIFIER	SOIC127P6-8	2N-CHMOSFET20V8.9A
18	R1, R174-175, R260, R263, R266, R275-282, R289-292	ERJ-3EKF3920V	PANASONIC	RESC0603	RES SMT, 392 OHM, 0.1W, 1%, 0603
22	R2-5, R7-8, R51, R77, R217, R227, R245-253, R257-258, R267	ERJ-3GEYJ512V	PANASONIC	RESC0603	RES SMT, 5.1K OHM, 0.1W, 5%, 0603
3	R6, R244, R272	ERJ-3EKF1001V	PANASONIC	RESC0603	RES SMT, 1K OHM, 0.1W, 1%, 0603
5	R9-12, R209	ERJ-3GEYJ242V	PANASONIC	RESC0603	RES SMT, 2.4K OHM, 0.1W, 5%, 0603
21	R13, R52, R54, R83, R86-87, R91, R93, R95, R100, R114-117, R136, R151, R172-173, R240, R259, R264	ERJ-3EKF1001V	PANASONIC	RESC0603	RES SMT, 1K OHM, 0.1W, 1%, 0603
67	R14-45, R55-73, R82, R85, R118, R120, R137, R146, R152, R157, R187, R198, R207, R226, R241-242, R256, R283	ERJ-3GEYJ822V	PANASONIC	RESC0603	RES SMT, 8.2K OHM, 0.1W, 5%, 0603
9	R46-48, R76, R80, R92, R210, R243, R274	ERJ-3GEYJ103V	PANASONIC	RESC0603	RES SMT, 10K OHM, 0.1W, 5%, 0603
8	R49, R148, R150, R158, R288, R293-295	ERJ-3GEYJ202V	PANASONIC	RESC0603	RES SMT, 2K OHM, 0.1W, 5%, 0603
4	R50, R74, R214, R265	ERJ-3GEYJ201V	PANASONIC	RESC0603	RES SMT, 200 OHM, 0.1W, 5%, 0603
2	R53, R273	ERJ-3GEYJ563V	PANASONIC	RESC0603	RES SMT, 56K OHM, 0.1W, 5%, 0603
2	R75, R236		PANASONIC	RESC0402	RES SMT, 10 OHM, 0.0625W, 5%, 0402
11	R78-79, R81, R84, R178, R284-287, R296, R299		PANASONIC	RESC0402	RES SMT, 33.2 OHM, 0.0625W, 1%, 0402
3	R88, R213, R238		VISHAY	RESC2010	RES SMT, 0.015 OHM, 0.5W, 1%, 2010, CURRENT SENSE
2	R89, R224	ERJ-3EKF1502V	PANASONIC	RESC0603	RES SMT, 15.0K OHM, 0.1W, 1%, 0603
1	R90	ERJ-3EKF1372V	PANASONIC	RESC0603	RES SMT, 13.7K OHM, 0.1W, 1%, 0603
14	R102, R149, R181, R199-206, R255, R268, R270	ERJ-2GE0R00X	PANASONIC	RESC0402	RES SMT, 0 OHM, 0.063W, 5%, 0402

**Table 23: Bill of Materials (Continued)**

Quantity	Reference Designator	Part Number	Manufacturer	Package Type	Description
4	R104, R107-109	ERJ-2RKF49R9X	PANASONIC	RESC0402	RES SMT, 49.9 OHM, 0.063W, 1%, 0402
4	R105-106, R111-112		PANASONIC	RESC0402	RES SMT, 33.2 OHM, 0.0625W, 1%, 0402
5	R113,R119,R124,R128, R262		PANASONIC	RESC0603	RES SMT, 475 OHM, 0.1W, 1%, 0603
1	R121	ERJ-3GEYJ473V	PANASONIC	RESC0603	RES SMT, 47K OHM, 0.1W, 5%, 0603
2	R122,R138		VISHAY	RESC2010	RES SMT, 0.100 OHM, 0.5W, 1%, 2010,CURRENT SENSE
1	R132	ERJ-3EKF7151V	PANASONIC	RESC0603	RES SMT, 7.15K OHM, 0.1W, 1%, 0603
1	R142	ERJ-3EKF1502V	PANASONIC	RESC0603	RES SMT, 15.0K OHM, 0.1W, 1%, 0603
3	R176-177, R179	ERJ-3GEYJ103V	PANASONIC	RESC0603	RES SMT, 10K OHM, 0.1W, 5%, 0603
2	R221,R230	ERJ-3EKF1103V	PANASONIC	RESC0603	RES SMT, 110K OHM, 0.1W, 1%, 0603
2	R222,R229	ERJ-2RKF1000X	PANASONIC	RESC0402	RES SMT, 100 OHM, .06W, 1%, 0402
2	R223,R225	9C06031A0R00JL HFT	YAGEO	RESC0603	RES SMT, 0 OHM, 0.1W, 5%, 0603
1	R228	ERJ-3GEYJ223V	PANASONIC	RESC0603	RES SMT, 22K OHM, 0.1W, 5%, 0603
2	R231-232	ERJ-8GEY0R00V	PANASONIC	RESC1206	RES SMT, 0 OHM, 0.25W, 5%, 1206
1	R233	ERJ-3GEYJ512V	PANASONIC	RESC0603	RES SMT, 5.1K OHM, 0.1W, 5%, 0603
1	R235		PANASONIC	RESC0603	RES SMT, 10K OHM, 0.1W, 1%, 0603
1	R237	9C06031A0R00JL HFT	YAGEO	RESC0603	RES SMT, 0 OHM, 0.1W, 5%, 0603
1	R261	ERJ-3GEYJ471V	PANASONIC	RESC0603	RES SMT, 470 OHM, 0.1W, 5% 0603
8	S1-8	1-1435790-4	TYCO	SW_1-1435790-4	DIPSWITCH,4SWITCHES
1	SW1	PTS125SM43	ITT/CANNON	PTS125	PUSHBUTTON SWITCH, 0.5 X 0.5
1	SW2	EVQPAC07K	PANASONIC	SW_EVQPAC07K	PUSHBUTTONSWITCH
6	TP1-6			TESTPOINT	
1	U1	MM74HC74AM	FAIRCHILD	SOIC127P6-14	DUAL D-TYPE FLIP-FLOP WITH PRESET AND CLEAR
3	U2-3,U32	LMC7221BIM5	NATIONAL	SOT23-5	CMOS COMPARATOR, R-TO-R INPUT,OPENDRAINOUTPUT

**Table 23: Bill of Materials (Continued)**

Quantity	Reference Designator	Part Number	Manufacturer	Package Type	Description
2	U4-5	SN74LVC1G14DBVT	TI	SOT23-5	SINGLE SCHMITT-TRIGGER INVERTER
1	U6	ICS87604AGI	IDT	TSOP65P81-28	LOW VOLTAGE, LOW SKEW 1:4 PCI/PCI-X ZERO DELAY CLOCK GENERATOR
1	U7	SN74LVC139AD	TI	SOIC127P6-16	DUAL 2-LINE TO 4-LINE DECODER/MULTIPLEXER
2	U9,U22		LINEAR	LTM4600EV_PBF	10A 4.5V TO 20V INPUT, 0.6V TO 5.0V OUTPUT SWITCHING REGULATOR
1	U10	ICS557M-01	ICS	SOIC127P6-8	100MHZ, HCSL OUT, 3.3V, 25MHZ INPUT (SUPPORTS PCIE)
1	U11	TSI384-133ILVZ2	IDT	BGA100P16X16-256	FORWARD MODE PCI EXPRESS TO PCI/X BRIDGE
1	U12	ICS557G-08	IDT	TSSOP65P64-16	2:1 MULTIPLEXER CHIP FOR PCI EXPRESS
1	U15	TL7702BCD	TI	SOIC127P6-8	PORGENERATOR,3.5-18VVCC
2	U16,U18	NC7SZ08M5X	FAIRCHILD	SOT23-5	TINY LOGIC 2-INPUT AND GATE 1.65V TO 5.5V
1	U26	LM4050_IM3-2.5	MAXIM	SOT23-3	SHUNT REFERENCE VOLTAGE 2.5V
1	U29	LTC4210-2CS6	LINEAR	TSOT23-6	HOTSWAPCONTROLLER
1	U33		INTERSIL	TSSOP50P49-10	MONOLITHIC 2A STEP DOWN REGULATOR, 1.5MHZ, 2.6-5V IN, 0.8 TO VIN OUT
3	U34-36	QS34XVH245Q3	IDT	QVSOP-80	32-BITFETBUSSWITCH
1	U37	EPM240T100C3	ALTERA	VQFP50P16X16-100	CPLD,240MACROCELL
2	Y1-2	HCM4925.000MABJT	CITIZEN	XTAL_HCM4925_000MABJT	25MHZ CRYSTAL, 18PF, 30PPM CAL.TOL.,50PPMTEMP.TOL.





## IMPORTANT NOTICE AND DISCLAIMER

RENESAS ELECTRONICS CORPORATION AND ITS SUBSIDIARIES (“RENESAS”) PROVIDES TECHNICAL SPECIFICATIONS AND RELIABILITY DATA (INCLUDING DATASHEETS), DESIGN RESOURCES (INCLUDING REFERENCE DESIGNS), APPLICATION OR OTHER DESIGN ADVICE, WEB TOOLS, SAFETY INFORMATION, AND OTHER RESOURCES “AS IS” AND WITH ALL FAULTS, AND DISCLAIMS ALL WARRANTIES, EXPRESS OR IMPLIED, INCLUDING, WITHOUT LIMITATION, ANY IMPLIED WARRANTIES OF MERCHANTABILITY, FITNESS FOR A PARTICULAR PURPOSE, OR NON-INFRINGEMENT OF THIRD-PARTY INTELLECTUAL PROPERTY RIGHTS.

These resources are intended for developers who are designing with Renesas products. You are solely responsible for (1) selecting the appropriate products for your application, (2) designing, validating, and testing your application, and (3) ensuring your application meets applicable standards, and any other safety, security, or other requirements. These resources are subject to change without notice. Renesas grants you permission to use these resources only to develop an application that uses Renesas products. Other reproduction or use of these resources is strictly prohibited. No license is granted to any other Renesas intellectual property or to any third-party intellectual property. Renesas disclaims responsibility for, and you will fully indemnify Renesas and its representatives against, any claims, damages, costs, losses, or liabilities arising from your use of these resources. Renesas' products are provided only subject to Renesas' Terms and Conditions of Sale or other applicable terms agreed to in writing. No use of any Renesas resources expands or otherwise alters any applicable warranties or warranty disclaimers for these products.

(Disclaimer Rev.1.01)

### Corporate Headquarters

TOYOSU FORESIA, 3-2-24 Toyosu,  
Koto-ku, Tokyo 135-0061, Japan  
[www.renesas.com](http://www.renesas.com)

### Trademarks

Renesas and the Renesas logo are trademarks of Renesas Electronics Corporation. All trademarks and registered trademarks are the property of their respective owners.

### Contact Information

For further information on a product, technology, the most up-to-date version of a document, or your nearest sales office, please visit [www.renesas.com/contact-us/](http://www.renesas.com/contact-us/).