

Evaluation Kit Hardware Manual

Renesas Evaluation Kit (EVK) supports the RA6W1 MCU, the RA6W2 MCU, and the RRQ610xx modules. This manual describes the system functions of the hardware as well as the guidelines of how to enable or disable features of the evaluation kit.

Contents

Contents	1
Figures	2
Tables	4
1. Terms and Definitions	6
2. Introduction	7
2.1 Evaluation Kit Hardware Block Diagram	10
3. Evaluation Kits for RA6W1/RA6W2/RRQ610x1	11
3.1 Evaluation Kits Hardware Components	11
3.2 Jumper Settings	12
3.2.1 EK-RA6W1 Motherboard	12
3.2.2 RRQ61051 Module Daughterboard	14
4. EK-RA6W1 Motherboard (565-11-x) - RTK7WBA6W1S01000BK	16
4.1 Power Section	18
4.2 Power Measurement Circuit	21
4.3 Power Measurements Setup	24
4.3.1 Case 1: Measure Power Consumption of the Wi-Fi-Only System	24
4.3.2 Case 2: Measure Power Consumption of the Wi-Fi Section in Combo Systems (Wi-Fi/Bluetooth LE) ...	25
4.3.3 Case 3: Measure Power Consumption of Bluetooth LE Subsystem in Combo Systems (Wi-Fi/Bluetooth LE)	26
4.3.4 Case 4: Measure Power Consumption of the Wi-Fi and Bluetooth LE Sections in Combo Systems (Wi-Fi/Bluetooth LE)	26
4.4 USB HUB (U301)	28
4.5 USB to UART (U302)	29
4.6 USB to SWD/UART (U401)	30
4.7 Level Translator	32
4.8 GPIOs and Breakout Headers J201/J203	35
4.8.1 Enable UART for Wi-Fi	39
4.8.2 Enable SWD	39
4.9 Push Buttons	39
4.10 PSRAM Memory	40
4.11 SDIO Interface	42
4.11.1 Configure SDIO	43
4.11.2 VDD_SDIO Power Setting	44
4.12 MikroBUS Interface	45
4.13 PMOD Interface	46

4.14	Wake-up	47
4.15	LEDs	48
5.	RA6W1 QFN Evaluation Daughterboard (565-07-x) - RTK7WBA6W1S02000BK	49
5.1	RA6W1 GPIOs and Interface to Motherboard	51
5.2	Reset	54
5.3	Clocks	54
5.4	QSPI NOR Flash	55
5.5	RF Section	56
6.	RA6W2 Daughterboard (781-01-x) - RTK7WBA6W2S05000B	57
6.1	RA6W2 GPIOs and Interface to Motherboard	59
6.2	Wi-Fi to Bluetooth LE Connectivity and Coexistence	61
6.3	Reset	62
6.4	Clocks	63
6.5	QSPI NOR Flash	64
6.6	RF Section	65
7.	RRQ610x1 Module Daughterboard (565-16-x) - RTK7WBRQ61S0x000BK	67
7.1	RRQ610x1-00x Module GPIOs and Interface to Motherboard	70
7.2	Wi-Fi to Bluetooth LE Connectivity and Coexistence for RRQ61051	73
7.3	Jumper Settings for RRQ61001 Modules	74
7.4	Reset and Push-buttons	75
7.5	The Crystal 32.768 kHz	75
7.6	RF Section	76
	Appendix A EK-RA6W1 Motherboard (565-11-E) - Assembly - Top	77
	Appendix B Regulatory Information	78
B.1	RA6W1 Evaluation Kit	78
B.1.1	FCC Notice (Applicable to Evaluation Kits not FCC-Approved)	78
B.1.2	CE (Radio Equipment Directive 2014/53/EU (RED)) – (Europe)	78
B.1.3	UKCA (UK)	79
B.1.4	MIC (Japan)	80
B.2	RA6W2 Evaluation Kit	80
B.2.1	FCC Notice (Applicable to Evaluation Kits not FCC-Approved)	80
B.2.2	CE (Radio Equipment Directive 2014/53/EU (RED)) – (Europe)	81
B.2.3	UKCA (UK)	81
B.2.4	MIC (Japan)	82
B.3	RRQ610xx Evaluation Kit	83
B.3.1	FCC Notice (Applicable to Evaluation Kits not FCC-Approved)	83
8.	Revision History	84

Figures

Figure 1.	The hardware components for RA6W1, RA6W2, and RRQ610xx EVKs	8
Figure 2.	Block diagram of the evaluation kit	10
Figure 3.	RA6W1 complete system of motherboard, daughterboard	11
Figure 4.	Default jumper settings for EK-RA6W1 motherboard	12
Figure 5.	Default jumper settings of the RRQ61051 module daughterboard	14

Figure 6. EK-RA6W1 motherboard block diagram	16
Figure 7. EK-RA6W1 motherboard	17
Figure 8. EK-RA6W1 motherboard power tree block diagram	18
Figure 9. EK-RA6W1 motherboard power circuit for I/O voltage	19
Figure 10. The power supply of VBAT_A	19
Figure 11. EK-RA6W1 motherboard 3.3 V power circuit to daughterboard	20
Figure 12. The LDOs for I/O_V1.8V and VDDIO	20
Figure 13. J2/J102/J104/J105/J106/J107 headers configuration	21
Figure 14. Power measurement circuit block diagram	22
Figure 15. Jumper setting for activating power measurements circuit	23
Figure 16. Apply jumper between Px_xx and TRIGx for enabling trigger	24
Figure 17. Hardware configuration for power measuring with power measurement circuit	24
Figure 18. Hardware configuration for power measuring with external equipment	25
Figure 19. Hardware configuration for power measuring with on-board power measurement circuit	25
Figure 20. Hardware configuration for power measuring with external equipment	26
Figure 21. Hardware configuration for power measuring with external equipment	26
Figure 22. Hardware configuration for power measuring with power measurement circuit	27
Figure 23. Hardware configuration for power measuring with external equipment	27
Figure 24. USB HUB circuitry	28
Figure 25. USB HUB power supply	28
Figure 26. USB to UART circuitry	29
Figure 27. USB to UART power supply	30
Figure 28. USB to JTAG/UART circuitry (U401) and UART header (J405)	30
Figure 29. Default SWD connection to Wi-Fi subsection	31
Figure 30. USB to SWD/UART circuitry – UART header, J405	31
Figure 31. Level translators block diagram	32
Figure 32. Voltage translator circuitry	34
Figure 33. J201/J203 schematic	35
Figure 34. J201/J203 position on EK-RA6W1 motherboard	36
Figure 35. Enabling UART0 on motherboard	39
Figure 36. Enabling SWD for Wi-Fi (jumper settings on J203)	39
Figure 37. Push buttons J607/J608/J609/J610	40
Figure 38. Push buttons position on the EK-RA6W1 motherboard	40
Figure 39. QSPI NOR Flash place holder on EK-RA6W1 motherboard	41
Figure 40. EK-RA6W1 motherboard (565-11-x)	41
Figure 41. The connectivity to PSRAM	41
Figure 42. QSPI PSRAM (U203) on EK-RA6W1 motherboard	41
Figure 43. SDIO interface	42
Figure 44. SDIO connection to an external MPU/MCU hardware platform	43
Figure 45. P1_10 to P1_15 assignment to SDIO	43
Figure 46. P0_8 to P0_13 for SDIO bus on EK-RA6W1	44
Figure 47. Supply SDIO pull-ups from external MCU/MPU hardware platform	44
Figure 48. Supplying SDIO pull-up from EK-RA6W1 motherboard	45
Figure 49. MikroBUS slot circuitry	45
Figure 50. Enabling mikroBUS signals on the J201/J203 breakout headers	46
Figure 51. PMOD female connector (mounted) slot circuitry	46
Figure 52. PMOD male connector (not mounted)	46
Figure 53. PMOD position on EK-RA6W1 motherboard	47
Figure 54. Wake-up function on EK-RA6W1 motherboard	48
Figure 55. LEDs interface, circuit (left) and PCB locationing	48
Figure 56. System block diagram of RA6W1 daughterboard	49
Figure 57. RA6W1 daughterboard component's placement	50
Figure 58. RA6W1 interface to Motherboard, Schematic	51
Figure 59. RA6W1 interface to motherboard PCB	52
Figure 60. Reset Button (J201) on RA6W1 daughterboard	54

Figure 61. QSPI-Flash circuitry on RA6W1 daughterboard	55
Figure 62. Connector (J202) for direct QSPI Flash programming	55
Figure 63. RF section circuitry of RA6W1 daughterboard	56
Figure 64. RF section of RA6W1 daughterboard	56
Figure 65. System block diagram of the RA6W2 daughterboard	57
Figure 66. RA6W2 daughterboard component's placement	58
Figure 67. RA6W2 interface to Motherboard, Schematic	59
Figure 68. RA6W2 interface to Motherboard PCB	59
Figure 69. Wi-Fi and Bluetooth LE sections connections on RA6W2 Daughterboard	61
Figure 70. Reset push-button. J201	62
Figure 71. XTALs of RA6W2 daughterboard	63
Figure 72. SPI-Flash circuitry on RA6W2 daughterboard	64
Figure 73. RF section circuitry of RA6W2 daughterboard	65
Figure 74. Selecting SMA or Printed Antenna on RA6W2 daughterboard	65
Figure 75. RF SPDT switch circuitry of RA6W2 daughterboard	65
Figure 76. RRQ610x1-009 uFL (left) and RRQ610x1-008 printed antenna (right)	67
Figure 77. System block diagram of RRQ61051 module	68
Figure 78. RRQ610x1 Daughterboard Component's placement (top left, bottom right)	69
Figure 79. RRQ610x1 Daughterboard Interface to Motherboard (left) and headers (right)	70
Figure 80. Wi-Fi and Bluetooth LE sections connections on Daughterboard for RRQ61051 Modules	73
Figure 81. Jumper settings for RRQ61001 daughterboard	74
Figure 82. Push-buttons of RRQ610x1 daughterboard	75
Figure 83. 32.768 kHz crystal	75
Figure 84. EK-RA6W1 motherboard (565-11-E) – components location on top layer	77
Figure 85. EU directive labels	79
Figure 86. UK Directive Labels	80
Figure 87. RA6W1 QFN66 Daughterboard (Model Number: RTK7WBA6W1S02000BK) GITEKI mark label	80
Figure 88. EU Directive Labels	81
Figure 89. UK Directive Labels	82
Figure 90. RA6W2 BGA93 Daughterboard (Model Number: RTK7WBA6W2S05000BK) GITEKI mark label	83

Tables

Table 1. RA6W1/RA6W2/RRQ610xx Evaluation Kit Part Numbers	7
Table 2. Components of evaluation kit	9
Table 3. Headers and jumper settings of the RA6W1 EVK motherboard	12
Table 4. Jumper settings of RRQ61051-00x module daughterboard	15
Table 5. Power section - default RAW1 EK motherboard setup	18
Table 6. Jumper settings for enabling power measurement circuit	23
Table 7. Connectivity of level translators	33
Table 8. Signals connectivity Evaluation Kit for RA6W1, RA6W2 and RRQ61xx	37
Table 9. Signals connectivity Evaluation Kit for RA6W1, RA6W2 and RRQ610xx (continued)	38
Table 10. Hardware modifications for enabling QSPI Flash (U202) on motherboard	41
Table 11. SDIO pin configuration	42
Table 12. GPIOs that can be used as Wake-up	47
Table 13. RA6W1 daughterboard part numbers and description	50
Table 14. Pins assignment for RRQ61001 daughterboard	53
Table 15. The RA6W2 daughterboard part numbers and description	58
Table 16. Pins assignment for RA6W2 daughterboard	60
Table 17. Connectivity Wi-Fi and Bluetooth LE section of RA6W2	62
Table 18. SKY13351 RF SPDT truth table	66
Table 19. RRQ610x1-00x variants	67
Table 20. Part numbers of the Evaluation Daughterboard for RRQ610x1-00x Module	67
Table 21. RRQ610x1-00x Daughterboard main components	69

Table 22. Daughterboard pins assignment for RRQ61001 Modules	71
Table 23. Daughterboard pins assignment for RRQ61051 Modules	72
Table 24. Connectivity Wi-Fi and Bluetooth LE section of RRQ61051 Modules	73
Table 25. RF switch control	73

1. Terms and Definitions

Bluetooth® LE	Bluetooth Low Energy
EVK	Evaluation Kit
FSP	Flexible Software Package
GPIO	General Purpose Input Output (pin)
IC	Integrated Circuit
JTAG	Joint Test Action Group
MCU	Microcontroller Unit
NP	Not Populated
OTP	One-Time Programmable Memory
PCB	Printed Circuit Board
PCBA	Printed Circuit Board Assembled
POR	Power-On Reset
RF	Radio Frequency
SWD	Serial Wire Debug
UART	Universal Asynchronous Receiver Transmitter
WLCSP	Wafer Level Chip Scale Package

2. Introduction

This manual describes the hardware of the RA6W1 evaluation kit (EVK). The RA6W1 EVK consists of a motherboard and one of the available daughterboards. Daughterboards vary according to IC type and/or package. All daughterboards present the same form factor and same interface as motherboard. Different daughterboard combined with the same motherboard produce different evaluation kits. In total three EVKs are described in this document:

- RA6W1 evaluation kit, consists of motherboard and RA6W1 daughterboard and is used for the development of RA6W1, Wi-Fi MCU.
- RA6W2 evaluation kit, consists of motherboard and RA6W2 daughterboard and is used for the development of RA6W2, Wi-Fi and Bluetooth LE system in package.
- RRQ610xx evaluation kit consists of motherboard and RRQ610x0-00x daughterboard and is used for RRQ610xx modules. There are four variants of RRQ610xx modules.

Table 1 presents all available RA6W1/RA6W2/RRQ610xx Evaluation Kit Part Numbers and their hardware composition.

Table 1. RA6W1/RA6W2/RRQ610xx Evaluation Kit Part Numbers

Device	Evaluation Kit part number	Motherboard	Evaluation Daughterboard	Antenna type
RA6W1 Evaluation Kit	RTK7WKA6W1S04000BK	RTK7WBA6W1S01000BK	RTK7WBA6W1S02000BK (RA6W1 QFN)	PCB Trace (SMA option)
RA6W2 Evaluation Kit	RTK7WKA6W2S03000BK	RTK7WBA6W1S01000BK	RTK7WBA6W2S05000BK (RA6W2 MCU)	PCB Trace (SMA option)
RRQ610xx Evaluation Kit	RTK7WKA6W1S00000BK	RTK7WBA6W1S01000BK	RTK7WBRQ61S01000BK (RRQ61001-008 Module)	PCB Trace
	RTK7WKA6W1S01000BK	RTK7WBA6W1S01000BK	RTK7WBRQ61S03000BK (RRQ61051-008 Module)	PCB Trace
	RTK7WKA6W1S02000BK	RTK7WBA6W1S01000BK	RTK7WBRQ61S04000BK (RRQ61051-009 Module)	u.FL connector

Note 1 Board-level part numbers identify individual motherboard and daughterboard assemblies and do not represent complete Evaluation Kits.

Note 2 Evaluation Kits based on RRQ61001-009 Wi-Fi-only modules are not included in [Table 1](#).

Table 2. Components of evaluation kit

Part number	Description	Name	Board name
RTK7WBA6W1S01000BK	Motherboard for RA6W1, RA6W2 and RRQ610xx modules evaluation, integrating low-power measuring circuit. A slot to connect evaluation daughterboards of RA6W1, RA6W2 and RRQ610xx modules.	EK-RA6W1 motherboard	565-11-E or later
RTK7WBA6W1S02000BK	Evaluation daughterboard with RA6W1 MCU, QFN 66 pin. Wi-Fi 6 Dual-band 2.4/5 GHz 802.11a/b/g/n/ax, 8 MB Flash. PCB trace antenna and option to support SMA connector.	RA6W1 evaluation daughterboard	565-07-x
RTK7WBA6W2S05000BK	Evaluation daughterboard with RA6W2 MCU, BGA 93 pin. Wi-Fi 6/Bluetooth LE combo. Wi-Fi 6 Dual-band 2.4/5 GHz 802.11a/b/g/n/ax, Bluetooth LE v5.1, 8 MB Flash. PCB trace antenna and option to support SMA connector.	RA6W2 evaluation daughterboard	781-01-x
RTK7WBRQ61S01000BK	Evaluation daughterboard with RRQ61001 module. Wi-Fi 6 Dual-band 2.4/5GHz 802.11a/b/g/n/ax, 8 MB Flash and PCB trace antenna.	RRQ61001-008 evaluation daughterboard	565-16-x
RTK7WBRQ61S02000BK	Evaluation daughterboard with RRQ61001 module. Wi-Fi 6 Dual-band 2.4/5 GHz 802.11a/b/g/n/ax, 8 MB Flash and u.FL connector.	RRQ61001-009 evaluation daughterboard	565-16-x
RTK7WBRQ61S03000BK	Evaluation daughterboard with RRQ61051 module. Wi-Fi 6/Bluetooth LE combo. Wi-Fi 6 Dual-band 2.4/5 GHz 802.11a/b/g/n/ax, Bluetooth LE v5.1, 8 MB Flash and PCB trace antenna.	RRQ61051-008 evaluation daughterboard	565-16-x
RTK7WBRQ61S04000BK	Evaluation daughterboard with RRQ61051 module. Wi-Fi 6/Bluetooth LE combo. Wi-Fi 6 Dual-band 2.4/5 GHz 802.11a/b/g/n/ax, Bluetooth LE v5.1, 8 MB Flash and u.FL connector.	RRQ61051-009 evaluation daughterboard	565-16-x

2.1 Evaluation Kit Hardware Block Diagram

Figure 2 shows the complete system block diagram of the evaluation kit.

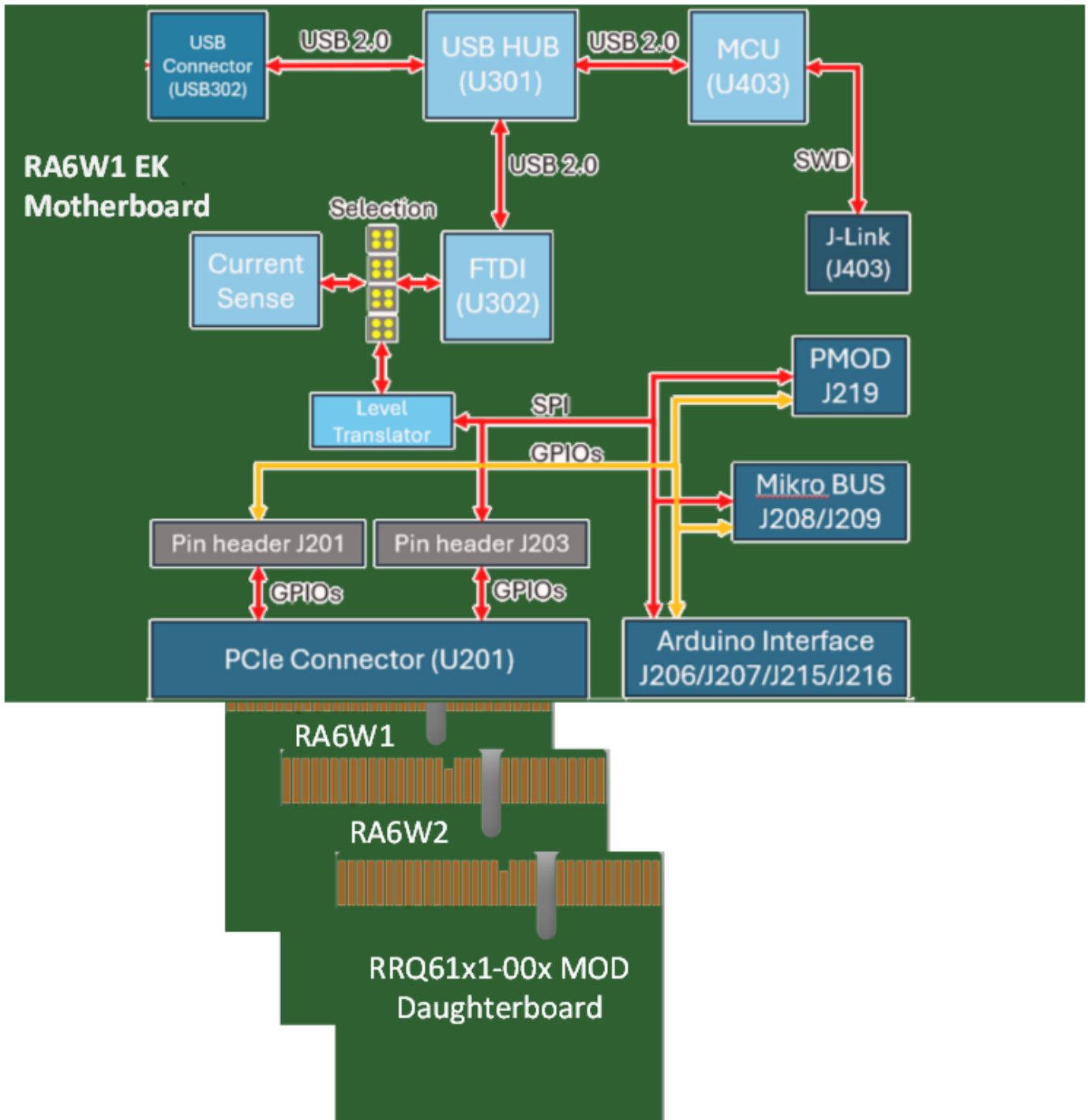

Figure 2. Block diagram of the evaluation kit

3. Evaluation Kits for RA6W1/RA6W2/RRQ610x1

3.1 Evaluation Kits Hardware Components

The three variants of RA6W1 EVK consist of the following parts:

- RA6W1 EVK
 - Motherboard, EK-RQ61, PCBA reference number 565-11-x
 - Daughterboard, RA6W1_db-wlcsp70, PCBA reference number 565-09-x
- Or
- Daughterboard, RA6W1_db-fcqn66, PCBA reference number 565-07-x
- RA6W2 EVK
 - Motherboard, EK-RQ61, PCBA reference number 565-11-x
 - Daughterboard, RA6W2_db, PCBA reference number 781-01-x
- RRQ610xx EVK
 - Motherboard, EK-RQ61, PCBA reference number 565-11-x
 - Daughterboard RRQ610xxMOD_db PCBA reference number 565-16-x with four variants based on module type assembled:
 - RRQ61001-008, Wi-Fi only with printed Antenna
 - RRQ61001-009, Wi-Fi only with u.FL
 - RRQ61051-008, Wi-Fi and Bluetooth LE with printed Antenna
 - RRQ61051-009, Wi-Fi and Bluetooth LE with u.FL.

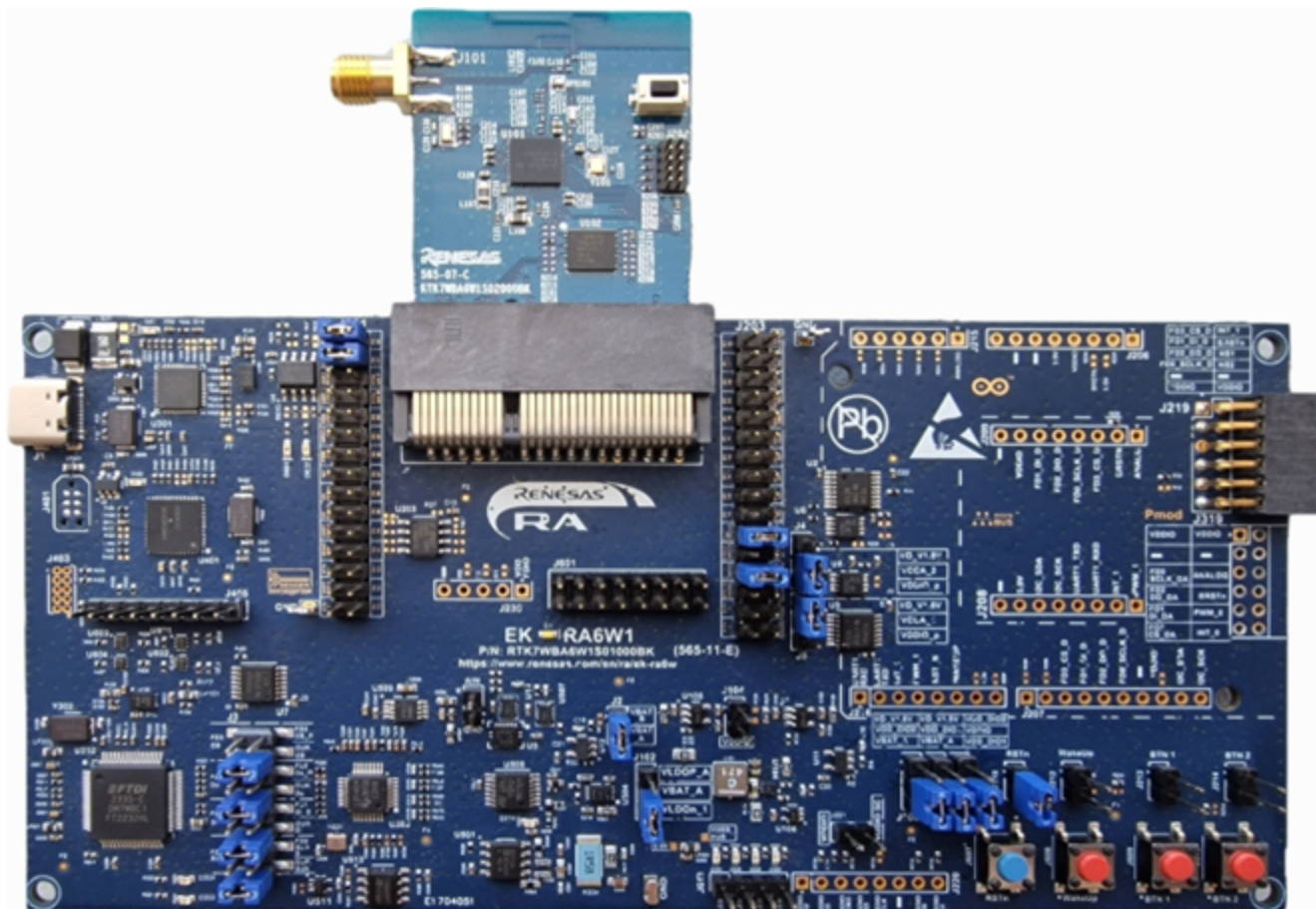

Figure 3. RA6W1 complete system of motherboard, daughterboard

3.2 Jumper Settings

With the EK-RA6W1 motherboard and RRQ61051 module daughterboard, you can modify system setup using different jumper settings. There are no jumper options for RA6W1, RA6W2, and RRQ61001 module daughterboards.

3.2.1 EK-RA6W1 Motherboard

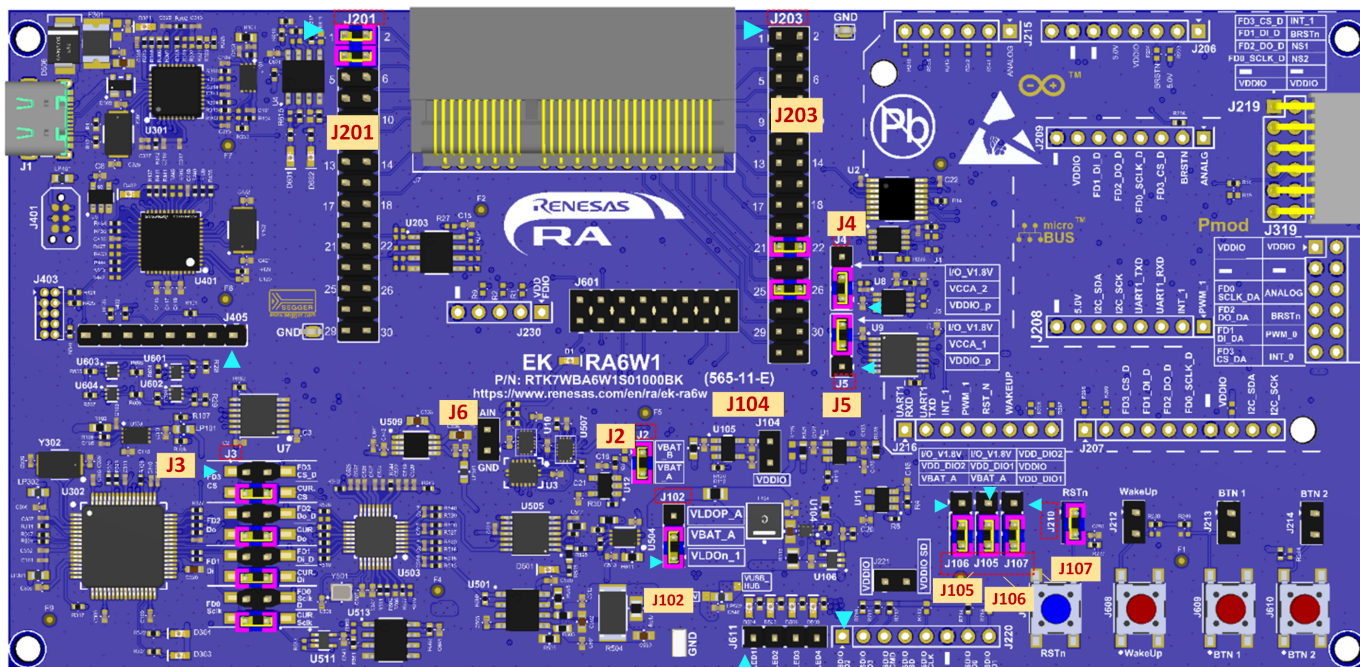

Figure 4. Default jumper settings for EK-RA6W1 motherboard

Table 3. Headers and jumper settings of the RA6W1 EVK motherboard

HDR	Function of headers	Jumper options	Default jumper setting	
J2	VBAT_B Power supply for Bluetooth LE subsection	Connect VBAT_A with VBAT_B	Mount J2	
J3	SPI interface switch between power measurement circuit and UART1/SPI to RA6W1	<ul style="list-style-type: none"> Option 1: SPI bus of power measurement section is connected to FT2232HL (USB to UART, U302) Option 2: UART1/SPI bus of RA6W1 MCU or RA6W2 is connected to FT2232HL (USB to UART, U302) Only one option is permitted.	Option 1: Mount pos. 3-4 Option 2: Mount pos. 1-2	Mount J3: 3-4
			Option 1: Mount pos. 7-8 Option 2: Mount pos. 5-6	Mount J3: 7-8
			Option 1: Mount pos. 11-12 Option 2: Mount pos. 9-10	Mount J3: 11-12
			Option 1: Mount pos. 15-16 Option 2: Mount pos. 13-14	Mount J3: 15-16
J4	SWD bus voltage range	SWDIO and SWCLK voltage range is set to VDDIO_p (= 3.3 V)	Mount pos. 1-2	Mount pos. 1-2

HDR	Function of headers	Jumper options		Default jumper setting
		SWDIO and SWCLK voltage range is set to I/O_V1.8 V (= 1.8 V)	Mount pos. 2-3	
J5	SPI bus voltage range	Voltage range for FD0_SCLK_DA, FD1_DI_DA, FD2_DO_DA and FD3_CS_DA is set to VDDIO_p (=3.3 V)	Mount pos. 1-2	Mount pos. 2-3
		Voltage range for FD0_SCLK_DA, FD1_DI_DA, FD2_DO_DA and FD3_CS_DA is set to I/O_V1.8 V (=1.8 V)	Mount pos. 2-3	
J6	AIN header	J6, pin2 is connected to analog input of Power measurement circuit. J6, pin 1 is connected to GND	Apply any analog signal to J6, pin2 (indicated AIN)	Do Not Mount jumper
J102	VBAT_A Power supply for Daughterboards, Wi-Fi subsection	Use with power measurement circuit	Mount pos. 1-2	Mount pos. 1-2
		Bypass power measurement circuit	Mount pos. 2-3	
J105	VDD_DIO1 voltage selection (1.8 V, 3.3 V)	I/O_V1.8V (=1.8 V)	Mount pos. 1-2	Mount pos. 1-2
		VBAT_A (=3.25 V – default)	Mount pos. 2-3	
J106	VDD_DIO2 voltage selection (1.8 V, 3.3 V)	I/O_V1.8V (=1.8 V)	Mount pos. 1-2	Mount pos. 1-2
		VBAT_A (=3.25 V – default)	Mount pos. 2-3	
J107	Set VDDIO voltage range. VDDIO is the IO voltage of the Interfaces (PMOD, MikroBUS™, Arduino, SDIO)	VDD_DIO2	Mount pos. 1-2	Mount pos. 2-3
		VDD_DIO1	Mount pos. 2-3	
J201	UART (Wi-Fi)	External (Personal Computer) access to daughterboards through UART pins P0_00 and P0_01	Mount pos. 1-2 Mount pos. 3-4	Mount pos. 1-2 Mount pos. 3-4
J203	SWD (Wi-Fi)	External (Personal Computer) access to daughterboards through SWD pins SWDIO and SWCLK	Mount pos. 21-22 Mount pos. 25-26	Mount pos. 21-22 Mount pos. 25-26
		No external access to UART	Not Mount jumpers	
J210	Jumper for connecting push-button J607 to RST_N of the Wi-Fi section	Connect to RST_N	Mount pos. 1-2	Mount pos. 1-2
J212	Enable Wake--up	Connect Push Button J608 to WAKEUP signal. Note that for enabling the function, WAKEUP must be connected to a GPIO.	Mount pos. 1-2	No Mounted
J213	Enable Push Button 1	Connect Push Button J609 to BTN1 signal. Note that for enabling the function, BTN1 must be connected to a GPIO.	Mount pos. 1-2	No Mounted
J214	Enable Push Button 2	Connect Push Button J610 to BTN2 signal.	Mount pos. 1-	No Mounted

HDR	Function of headers	Jumper options	Default jumper setting
		Note that for enabling the function, BTN1 must be connected to a GPIO.	2ount pos. 1-2

Note 1 Jumpers must be also placed on pairs of pins 1-2, 3-4, 4-5, and 5-6 of J203. SPI/UART is assigned to P1_00, P1_01, P1_02, and P1_03 respectively.

3.2.2 RRQ61051 Module Daughterboard

Table 4 shows the jumper settings for the daughterboard of RRQ61051 module.

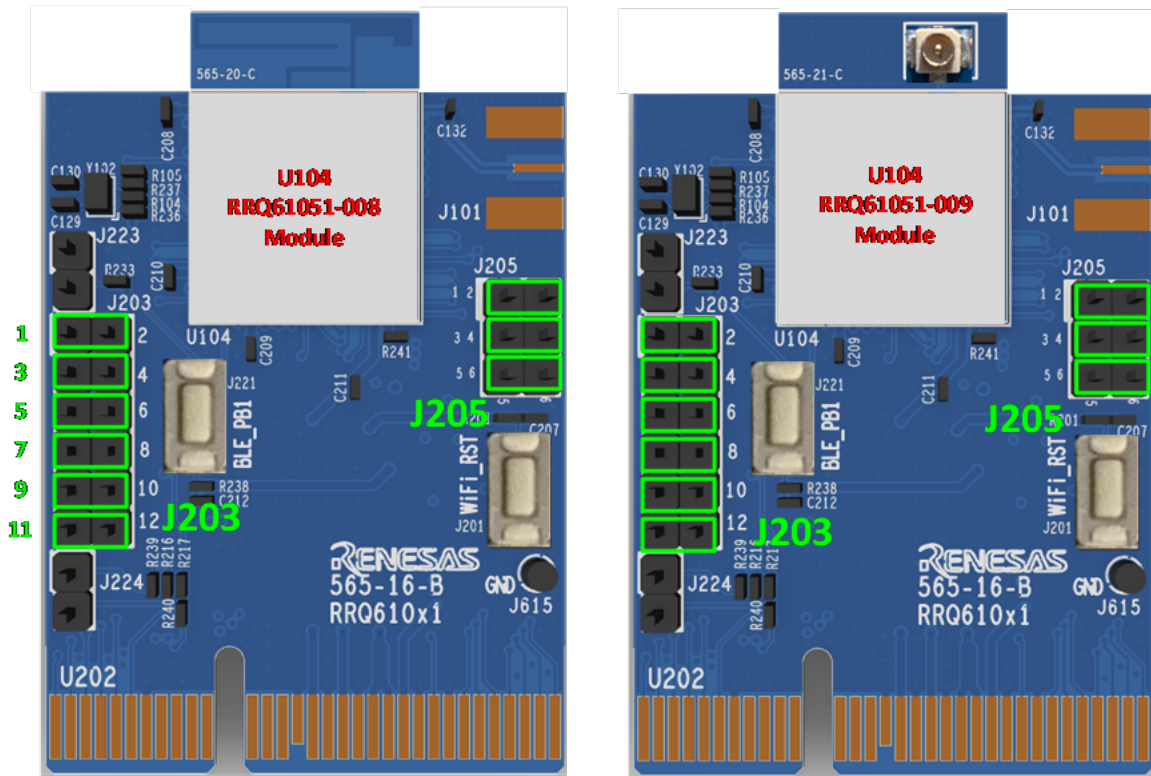

Figure 5. Default jumper settings of the RRQ61051 module daughterboard

Table 4. Jumper settings of RRQ61051-00x module daughterboard

HDR	Function of headers	Jumper options	Mount pos.	Default jumper setting
J203	Pin1: B_P0_00 Pin2: P1_10	Connect UTX (Bluetooth LE) to URX (Wi-Fi)	Mount pos. 1-2	Mount pos. 1-2
	Pin3: B_P0_01 Pin4: P1_11	Connect URX (Bluetooth LE) to UTX (Wi-Fi)	Mount pos. 3-4	Mount pos. 3-4
	Pin5: B_P0_03 Pin6: P1_12	Connect URTS (Bluetooth LE) to UCTS (Wi-Fi)	Mount pos. 5-6	Mount pos. 5-6
	Pin7: B_P0_04 Pin8: P1_13	Connect UCTS (Bluetooth LE) to URTS (Wi-Fi)	Mount pos. 7-8	Mount pos. 7-8
	Pin9: B_P0_02 Pin10: P1_14	Connect RST (Bluetooth LE) to RST_N (Wi-Fi)	Mount pos. 9-10	Mount pos. 9-10
	Pin11: B_P0_05 Pin12: P1_15	Connect iBtAct (Bluetooth LE) to Coex (Wi-Fi)	Mount pos. 11-12	Mount pos. 11-12
J205	pin1: P0_06 pin2: RFSW1	Activate RF Switch. Connect P0_06 with RFSW1	Mount pos. 1-2	Mount pos. 1-2
	Pin3: P0_07 Pin4: RF_SW2	Activate RF Switch Connect P0_07 with RFSW2	Mount pos. 3-4	Mount pos. 3-4
	Pin5: VBAT_BLE Pin6: VBAT_BLE+M	Supply Bluetooth LE	Mount pos. 5-6	Mount pos. 5-6

NOTE

No jumpers are required for the daughterboard with the RRQ61001 module.

4. EK-RA6W1 Motherboard (565-11-x) - RTK7WBA6W1S01000BK

Figure 6 and Figure 7 show the block diagram and the actual component locations of the motherboard.

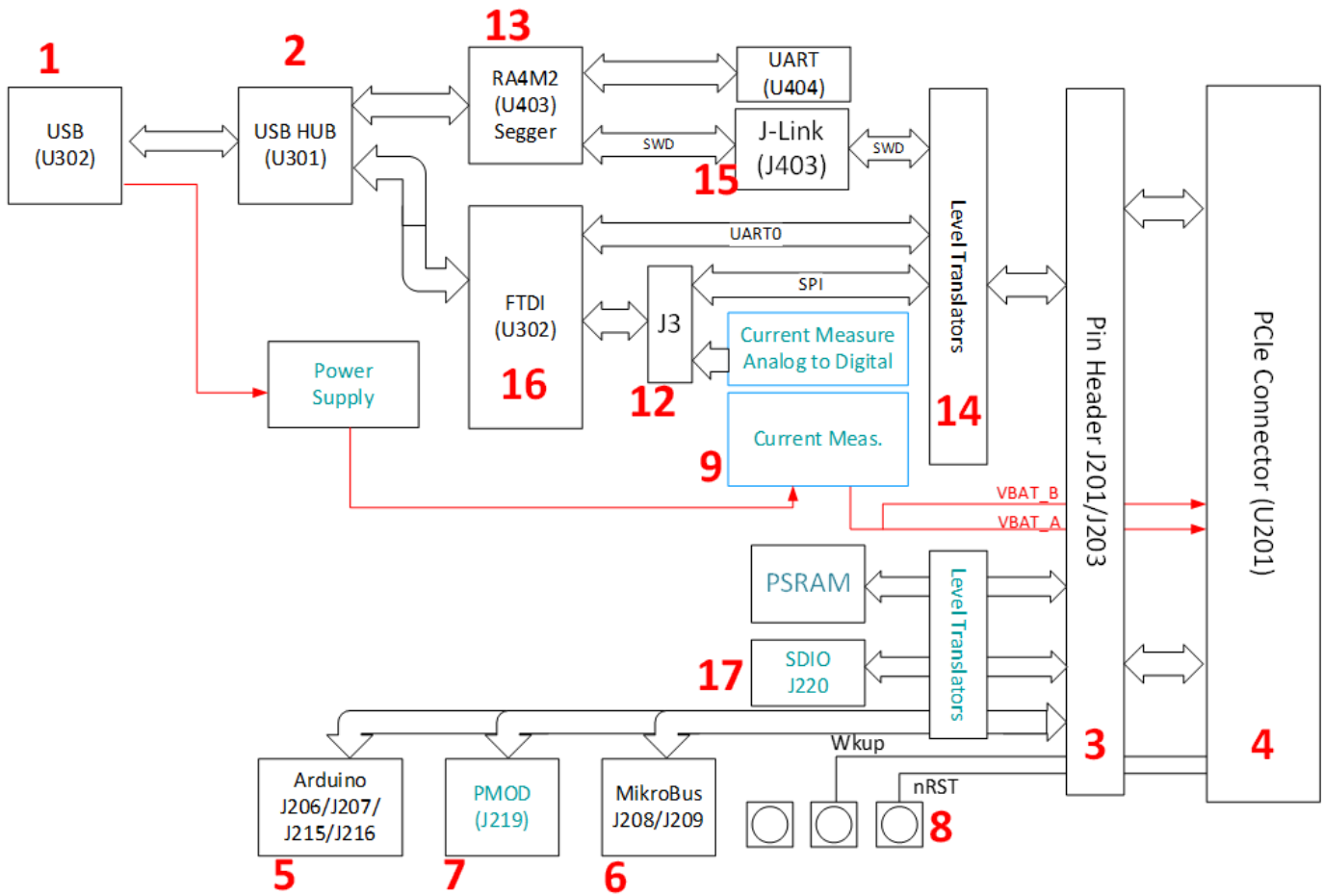

Figure 6. EK-RA6W1 motherboard block diagram

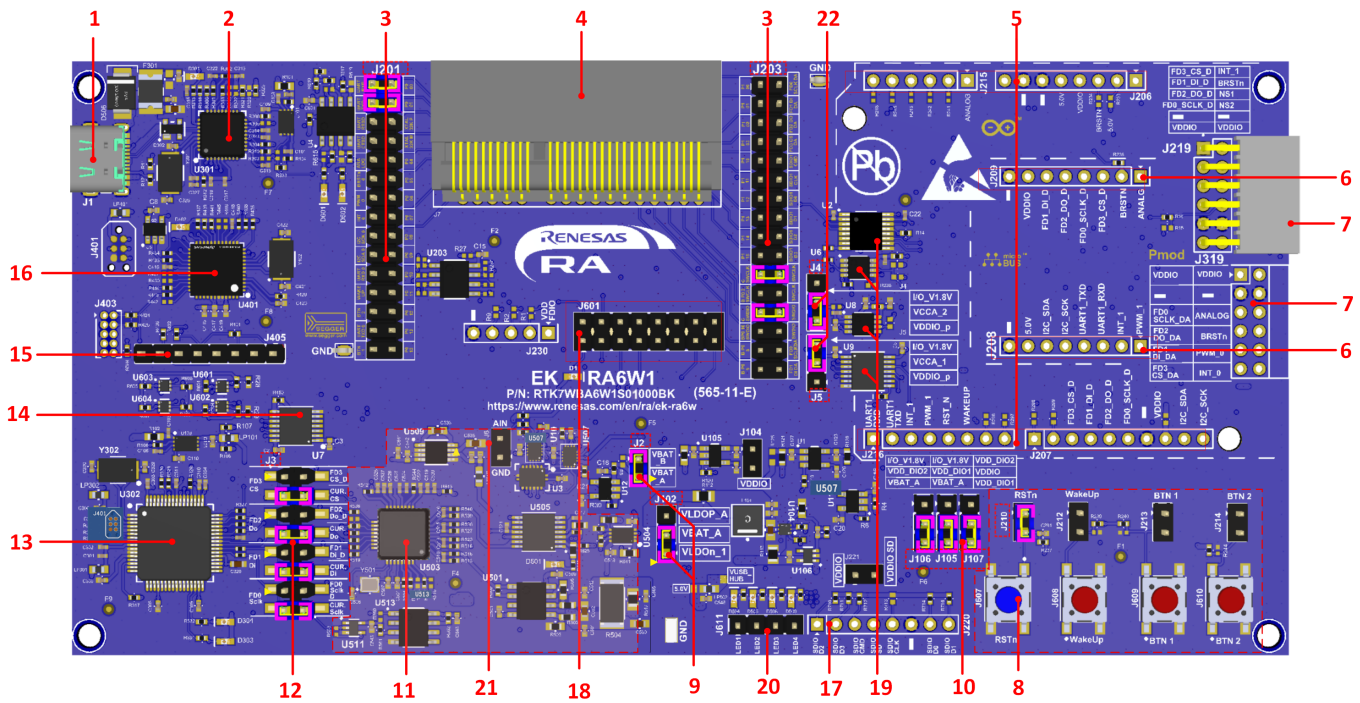

Figure 7. EK-RA6W1 motherboard

1. EK Motherboard Type C - USB connector (**J1**), power and data port for the RA6W1 EVK.
2. **USB hub (U301)**: connects JTAG and UART interfaces to the PC.
3. **Signal/Power breakout headers (J201/J203)**: exposes all the pins of the daughterboard and the motherboard to allow wiring for custom configurations as well as monitoring of the hardware signals.
4. **Daughterboard connector (J7)**: an interface mating connector for the daughterboard.
5. **Arduino sockets (J206/J207/J215/J216)**: sockets for plugging in Arduino interface add-on boards.
6. **MikroBUS™ sockets (J208/J209)**: sockets for plugging in MikroBUS™ interface add-on boards. It is multiplexed with PMOD (to be used with DA1453x).
7. **PMOD connectors (J219)**: socket for plugging in PMOD interface add-on boards. J319 is a header, No mounted. J219 and J319 share some signals which are multiplexed with MikroBUS™.
8. **Push buttons (J607/J608/J609/J610)**: J607 push button is used to resetting daughterboard, J608 is used for wake-up whereas J609 and J610 are used as BTN1 and BTN2 general-purpose buttons respectively. For each push button there is a corresponding header which enables it by applying a jumper. All buttons except J607 (nRST) are not enabled by default.
9. **Power selection (J102/J2)**: enabling or bypassing the current measurement circuit. When enabled, you can monitor the current consumption of daughterboard through Smart Snippets Toolbox software application. Bluetooth LE subsection is supplied though header J2.
10. **I/O voltage selection (J105, J106, and J107)**: select the I/O voltage applied to the daughterboard (1.8 V, 3.3 V).
11. **Power measurement circuitry**: it includes current sense resistor (R504), ADC (U503), analog and digital components.
12. **SPI interface switch (J3)**: switch of SPI interface of U302 (UART to USB) between power measurement circuit and UART0/SPI of RA6W1.
13. **USB to UART (U302)**: provides communication between daughterboard UART port and PC. It also transfers the current measurement samples to PC.
14. **Level translators (U7)**: transfer the data between daughterboard and FTDI (U302) in proper voltage level.
15. **External J-link connector (J405)** for accessing Wi-Fi MCU or Bluetooth LE MCU.
16. **MCU (U403)** where the SWD implementation of SEGGER applied.
17. **SDIO header (J220)**: provides access to the SDIO signals. Not mounted by default.
18. **Trigger (J601)**: the trigger signals monitored and presented on **Smart Snippets Toolbox**.
19. **Level translators (U2/U6/U8/U9)**: for the interface section (PMOD, Android, and MikroBUS).

- 20. **LEDs (J611):** four LEDs are connected to this header. For enabling an LED, a jumper wire must be connected between a GPIO and one of the pins of J611.
- 21. **AIN Header (J6):** an analog signal can be connected to pin2 of J6 with a jumping wire. The analog signal is connected to the power measurement circuit.
- 22. **Headers** for setting the voltage range of level translators for SWD bus (J4) and SPI interface (J5).

4.1 Power Section

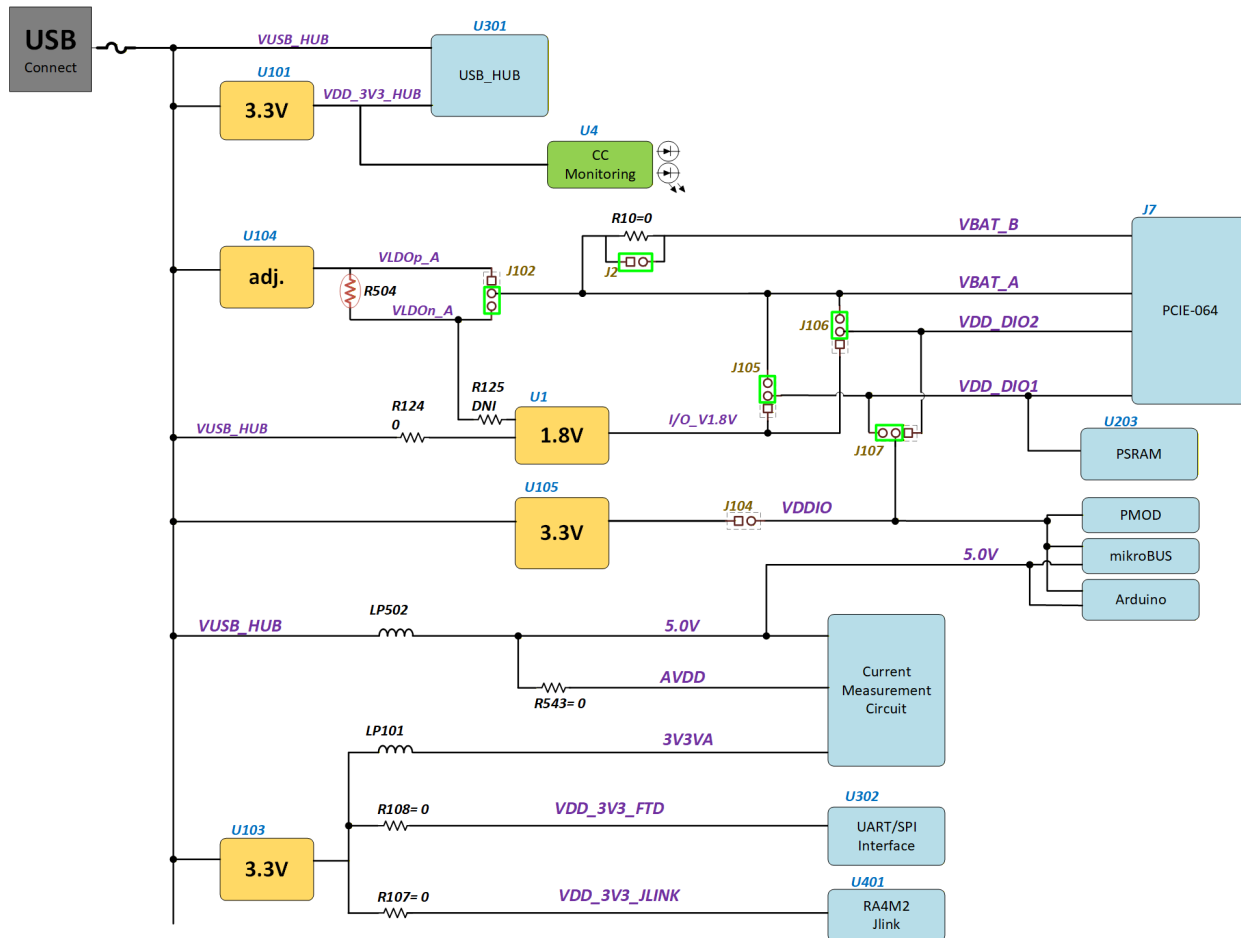

Figure 8. EK-RA6W1 motherboard power tree block diagram

The power tree of the EK-RA6W1 motherboard (Figure 8) consists of several power domains, the VUSB_HUB (= 5 V) power supply, the 3.3 V voltage rail supply for the supporting circuits of motherboard (RA4M2-jlink, USB Hub, FTDI), the main supply for daughterboards (VBAT_A and VBAT_B), the I/O voltage supplies for daughterboards (VDD-DIO1, VDD_DIO2) and the I/O voltage supply for interfaces (PMOD, Arduino, and mikroBUS).

Table 5. Power section - default RAW1 EK motherboard setup

Voltage rate	Jumper settings	Description
VBAT_A = 3.25 V	No jumper required	Wi-Fi subsection main supply
VBAT_B = 3.25 V	J2 mounted	Bluetooth LE subsection main supply
VDD_DIO1 = 3.25 V	Jumper is mounted on J105, 1-2	IO1 of Wi-Fi subsystem and PSRAM
VDD_DIO2 = 3.25 V	Jumper is mounted on J106, 1-2	IO1 of Wi-Fi subsystem
VDDIO = 3.25 V	Jumper is mounted on J107, 1-2	PMOD, Arduino, and mikroBUS
VDD_3V3_FTD = 3.3 V	No jumper required	USB to UART/SPI, U302, FT2232HL
VDD_3V3_JLINK = 3.3 V	No jumper required	USB to JTAG, U403, RA4M2
VDD_3V3_HUB = 3.3 V	No jumper required	U301, USB HUB, USB2512B

The daughterboard is powered from the J102/J2:

- I/O voltage (1.8 V or 3.3 V)
- 3.3 V system power for daughterboard.

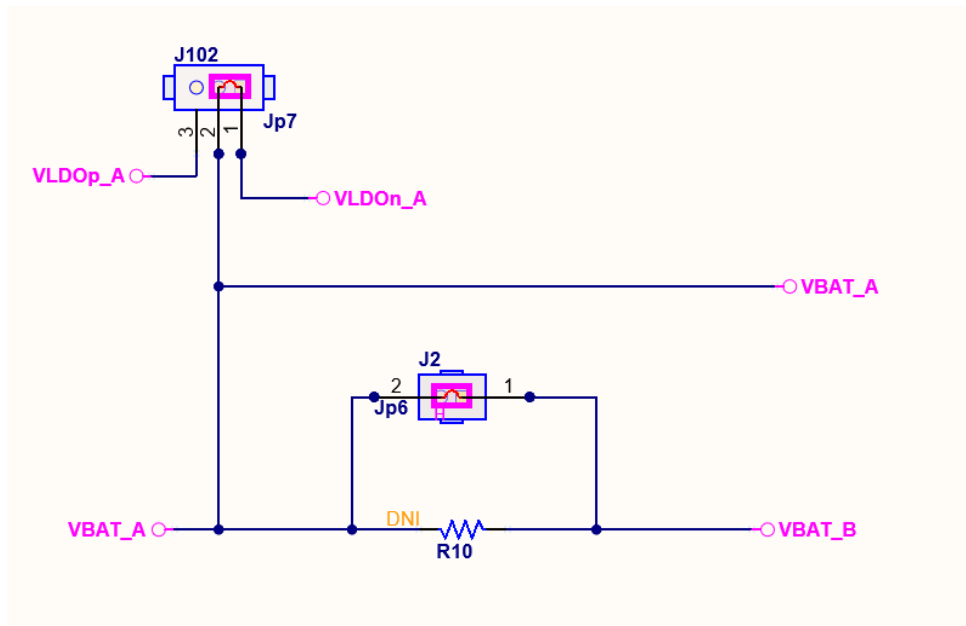
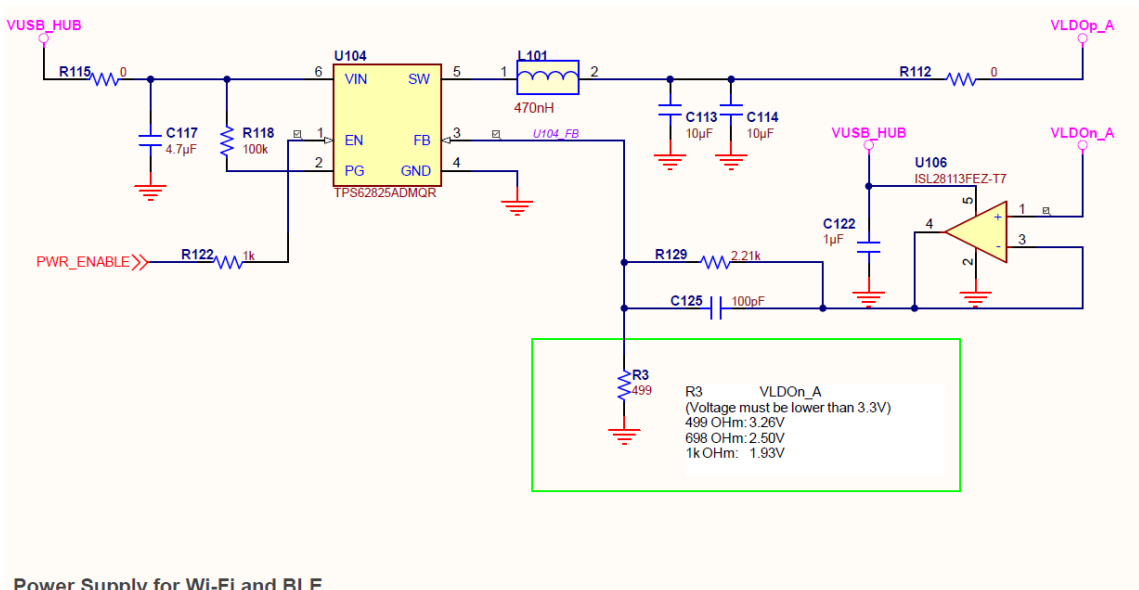

Figure 9. EK-RA6W1 motherboard power circuit for I/O voltage

Daughterboards are supplied from:

- J102: provides VBAT_A, the main power supply for the Wi-Fi subsystem voltage. VBAT_A is equal to 3.25 V and it is supplied from a 1 Amp DCDC converter (U104), see Figure 8.
- For changing VBAT_A, change resistor R3. Do not set VBAT_A higher than 3.25 V.



Power Supply for Wi-Fi and BLE

Figure 10. The power supply of VBAT_A

- J2: provides VBAT_B, the power supply for Bluetooth, where it is applicable. VBAT_B is connected directly to VBAT_A. J2 is used for current consumption measurement using an external Amp-meter.
- J105: provides VDD_DIO1 to Wi-Fi subsystem. It can be set equal to VBAT_A (default) or I/O_V1.8V = 1.8 V I/O_V1.8 V is generated from U1
- J106: provides VDD_DIO1 to Wi-Fi subsystem. It can be set equal to VBAT_A (default) or I/O_V1.8 V = 1.8 V I/O_V1.8 V is generated from U1

- U1 is LDO which can be supplied by either the USB port of motherboard (VUSB_HUB) or VBAT_A. By default, U1 is supplied from VUSB_HUB.

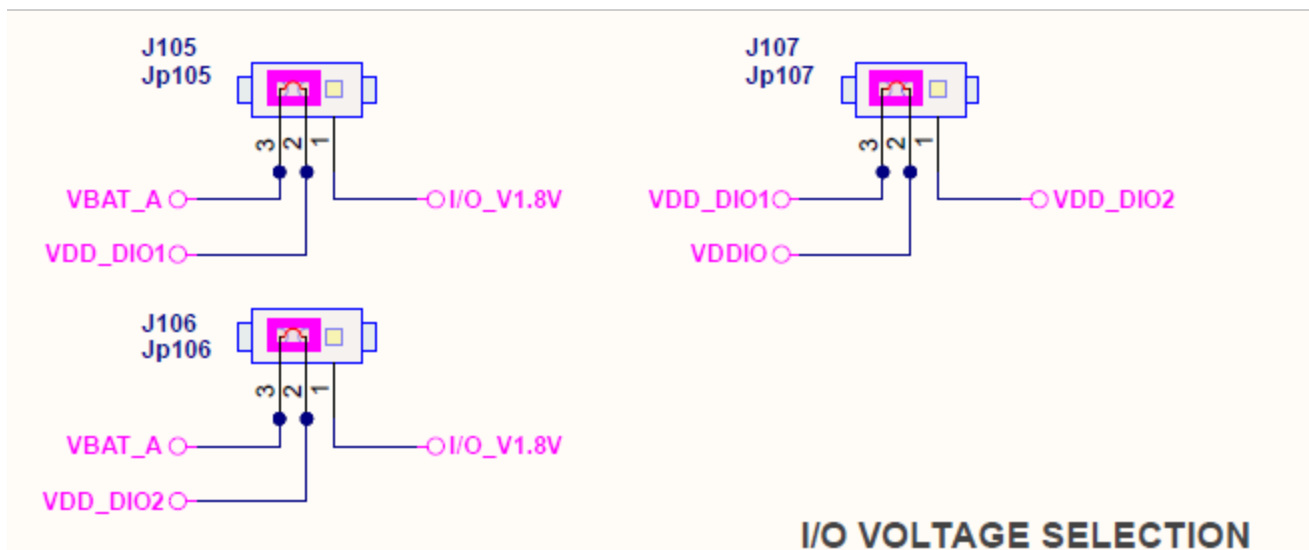

Figure 11. EK-RA6W1 motherboard 3.3 V power circuit to daughterboard

- J107: provides VDDIO to the interface section, PMOD, Arduino, and mikroBUS. VDDIO can be either supplied from VDD_DIO1 or VDD_DIO2 or with 3.3 V generated from LDO, U105.
- For supplying interface section with 3.3 V, remove a jumper from J107. And apply the jumper on J104, see Figure 12.
- J230: on pin 1, VDD_FDIO is monitored. VDD_FDIO is produced by RA6W1 or RA6W2. It is not available on the daughterboards of the RRQ610x1 modules. J230 is not mounted.

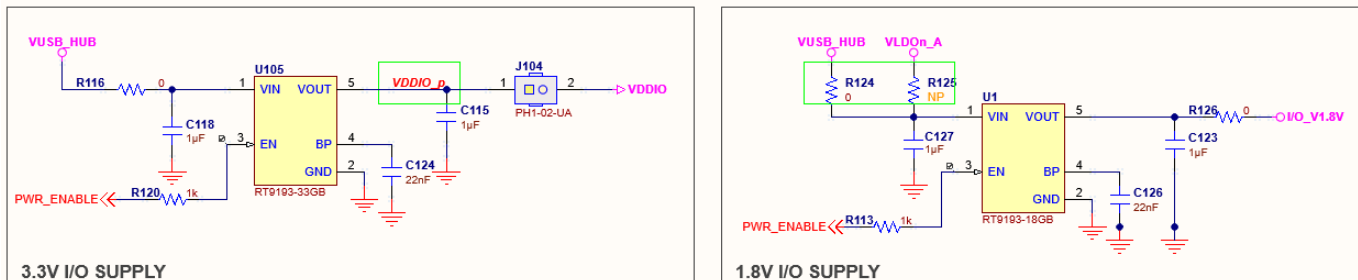

Figure 12. The LDOs for I/O_V1.8V and VDDIO

Figure 13 shows the configuration on PCB of EK-RA6W1 motherboard for the jumpers, J2/J102/J104/J105/J106/J107.

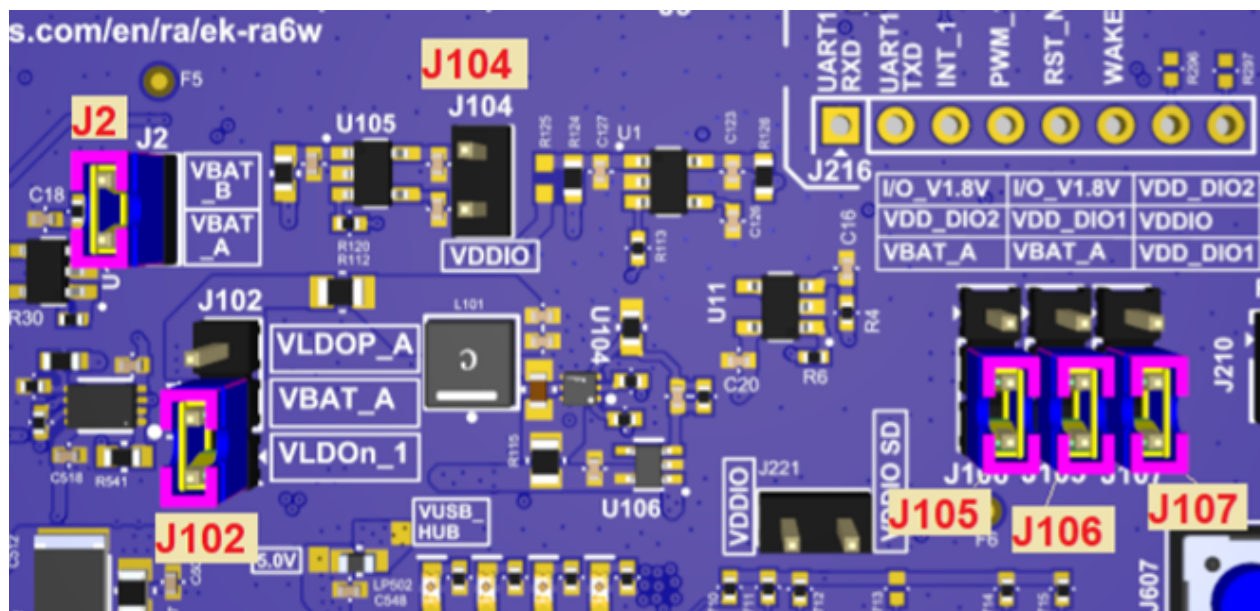

Figure 13. J2/J102/J104/J105/J106/J107 headers configuration

4.2 Power Measurement Circuit

A power measurement circuit is applied on the EK-RA6W1 motherboard.

NOTE

SmartSnippets Toolbox software application is required for the monitoring of the voltages and the signals triggering. [SmartBond™ Development Tools | Renesas](#)

In the EK-RA6W1 motherboard, the power measurement circuit is placed on board and measures the current drawn from daughterboards. It measures the combined power consumption of the Wi-Fi and Bluetooth LE (for the daughterboards which feature Wi-Fi and Bluetooth LE). In addition to power measurements, you can monitor up to eight software trigger signals and depict them to Smart Snippets Toolbox.

The power measurement unit has the following features:

- Full scale range 500 mA at 3.3 V
- Measure accurately down to 1 μ A
- Current sense resistors
- 1.58 Ω in series to VLDO for Wi-Fi
- Analog processing blocks
- Fast quad channel 24-bit ADC with SPI interface
- FTDI chip for transferring data to the PC
- Software trigger circuit.

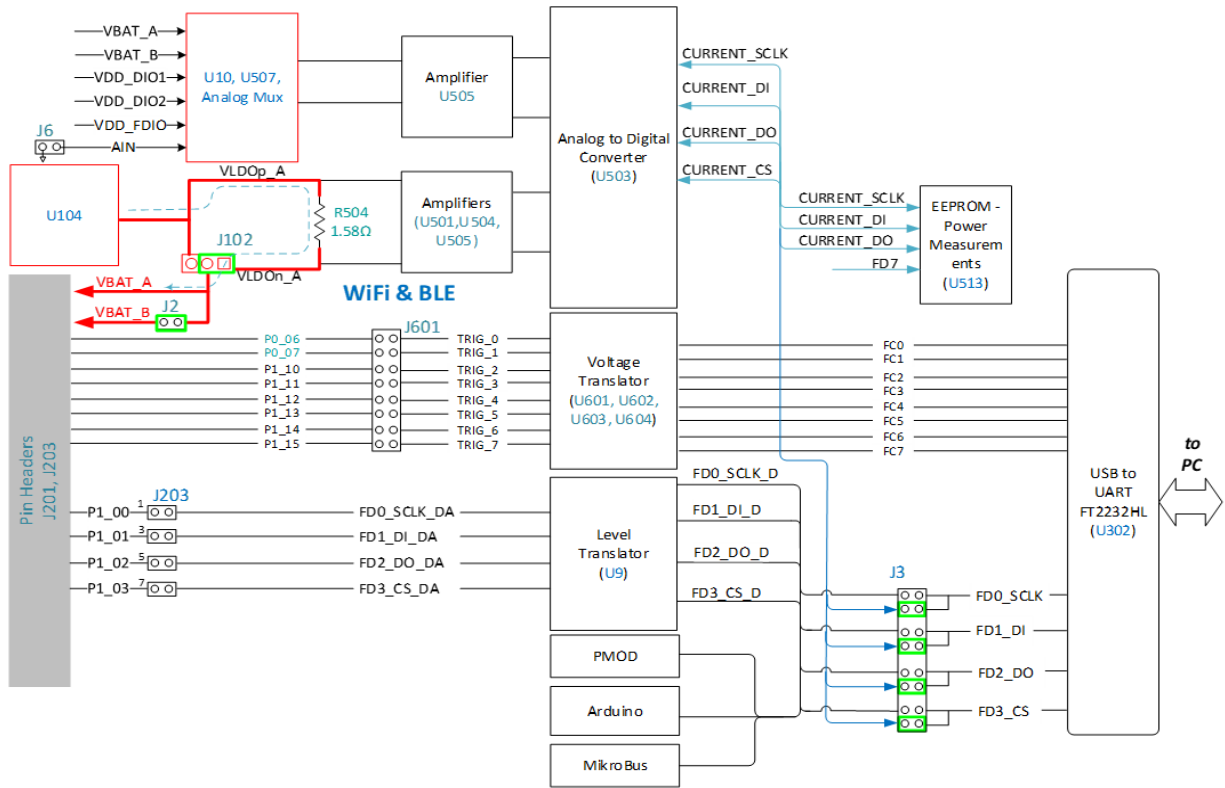

Figure 14. Power measurement circuit block diagram

The input to the circuit is the voltage across the sense resistors R504. The voltage across the sense resistors is sampled simultaneously by two differential amplifier stages and is converted by the ADC to a digital value. The low range has a conversion gain of 6.114 V/A and covers up to about 500 mA depending on the VBAT_A voltage rail. Up to two voltage rails can be monitored simultaneously. You can select through software (SmartSnippet Toolbox) among, VBAT_A, VBAT_B, VDD_DIO1, VDD_DIO2, VDD_FDIO and AIN. AIN is a generic Analog Input which is accessible on J6 header. You can connect with a jumper wire an analog signal with range 0 to 5 V. An EEPROM memory is used to store production data and allows the host software to autodetect the module. For enabling power measurement circuit, apply the jumpers from [Table 6](#).

Table 6. Jumper settings for enabling power measurement circuit

HDR	Function of headers	Jumper options		Jumper setting for enabling power measurement circuit
J3	SPI interface switch between power measurement and UART1/SPI to RA6W1	<ul style="list-style-type: none"> ▪ Option 1: SPI bus of power measurement section is connected to FT2232HL (USB to UART, U302) ▪ Option 2: UART1/SPI bus of RRQ610xxx is connected to FT2232HL (USB to UART, U302) Only one option is permitted.	Option 1: Mount pos. 3-4 Option 2: Mount pos. 1-2	Mount J3: 3-4
			Option 1: Mount pos. 7-8 Option 2: Mount pos. 5-6	Mount J3: 7-8
			Option 1: Mount pos. 11-12 Option 2: Mount pos. 9-10	Mount J3: 11-12
			Option 1: Mount pos. 15-16 Option 2: Mount pos. 13-14	Mount J3: 15-16
J2	Power supply for Bluetooth LE (3.3 V)	Connect VBAT_A to VBAT_B. VBAT_B supplies Bluetooth LE subsection (where it is available).		Mount pos. 1-2
J102	Power supply for Daughterboard VBAT_A	Use with power measurement circuit.	Mount pos. 1-2	Mount pos. 1-2
		Bypass power measurement circuit.	Mount pos. 2-3	

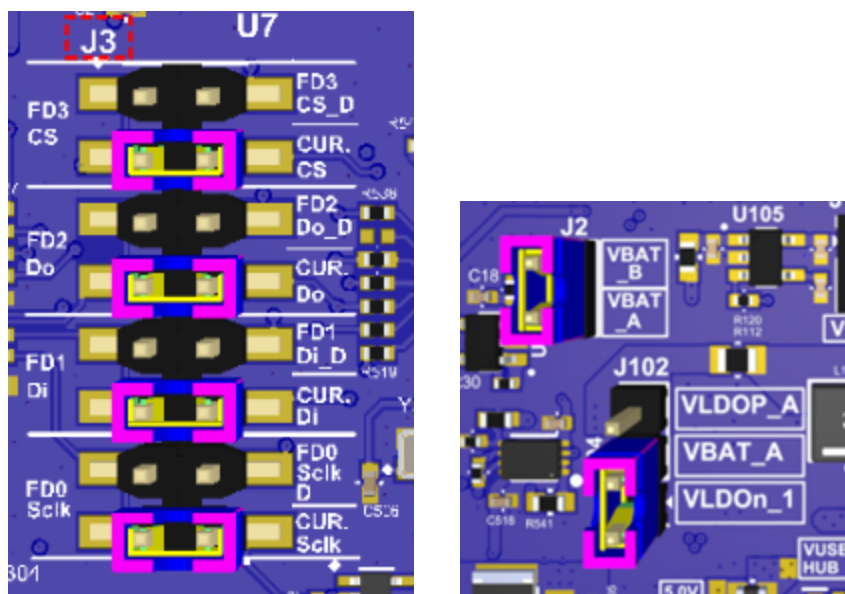

Figure 15. Jumper setting for activating power measurements circuit

Finally, there are eight trigger options defined (TRIG_0 to TRIG_7).

As shown in Figure 13, suitable jumpers on the J601 header allow you to directly select any of the available signals. On a combined Wi-Fi with Bluetooth LE solutions, P0_06 and P0_07 are used for driving the RF Switch, and consequently, they can be used for indicating the operation of each subsystem.

Any other GPIO can be used as a trigger source by connecting any of the TRIG_x pins with a jumper wire to the desired position at breakout headers (J201 or J203).

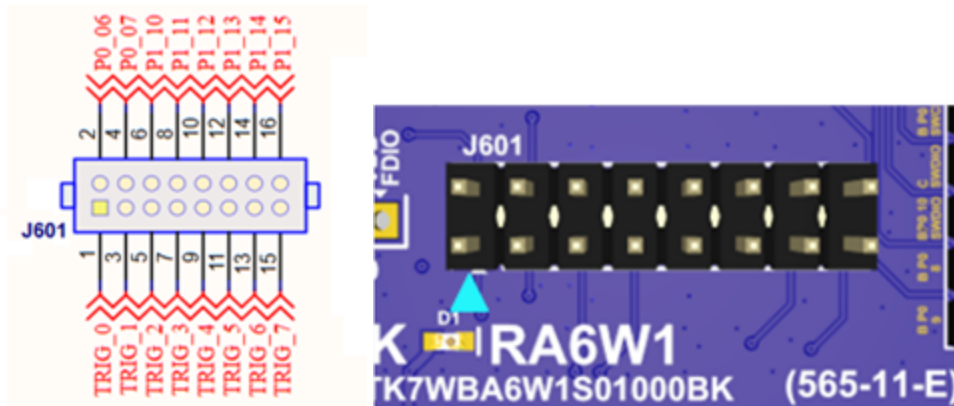

Figure 16. Apply jumper between Px_xx and TRIGx for enabling trigger

Dual MOSFET U601 to U604, buffer the signals to provide compatibility with 1.2 to 5 V I/O levels.

4.3 Power Measurements Setup

This section describes the hardware configurations which must be applied on the EK-RA6W1 motherboard, for measuring the current drawn from evaluation boards. Measurements can be achieved by using either the on-board Power Measurement Circuit or by external equipment (Amp-meter). The power consumption of Wi-Fi subsystem, Bluetooth LE subsystem or both.

4.3.1 Case 1: Measure Power Consumption of the Wi-Fi-Only System

You can measure the power consumption of the Wi-Fi-only systems on following evaluation boards/MCU or modules:

- RTK7WBA6W1S02000BK, RA6W1 MCU
- RTK7WBRQ61S01000BK, RRQ61001-008 Module
- RTK7WBRQ61S02000BK, RRQ61001-009 Module

You can perform the power measurement in one of the ways:

- Use on-board power measurement circuit:
 - a. Apply jumper on J2.
 - b. Apply jumper on J102 pin VLDOOn_1 to J102, pin VBAT_A.

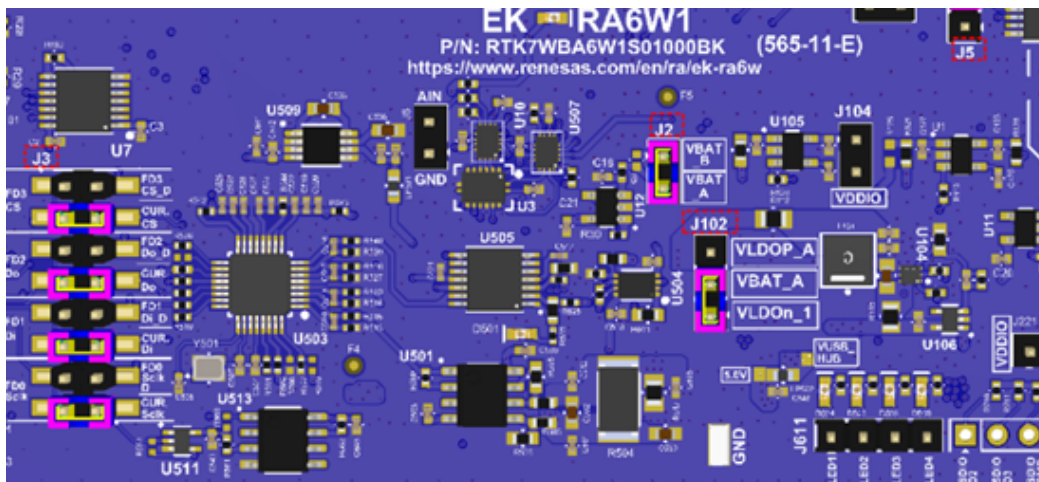

Figure 17. Hardware configuration for power measuring with power measurement circuit

- Use external equipment:
 - a. Remove jumper from J102.
 - b. Connect an amp-meter to J102 pins VLDOP_A and VBAT_A.

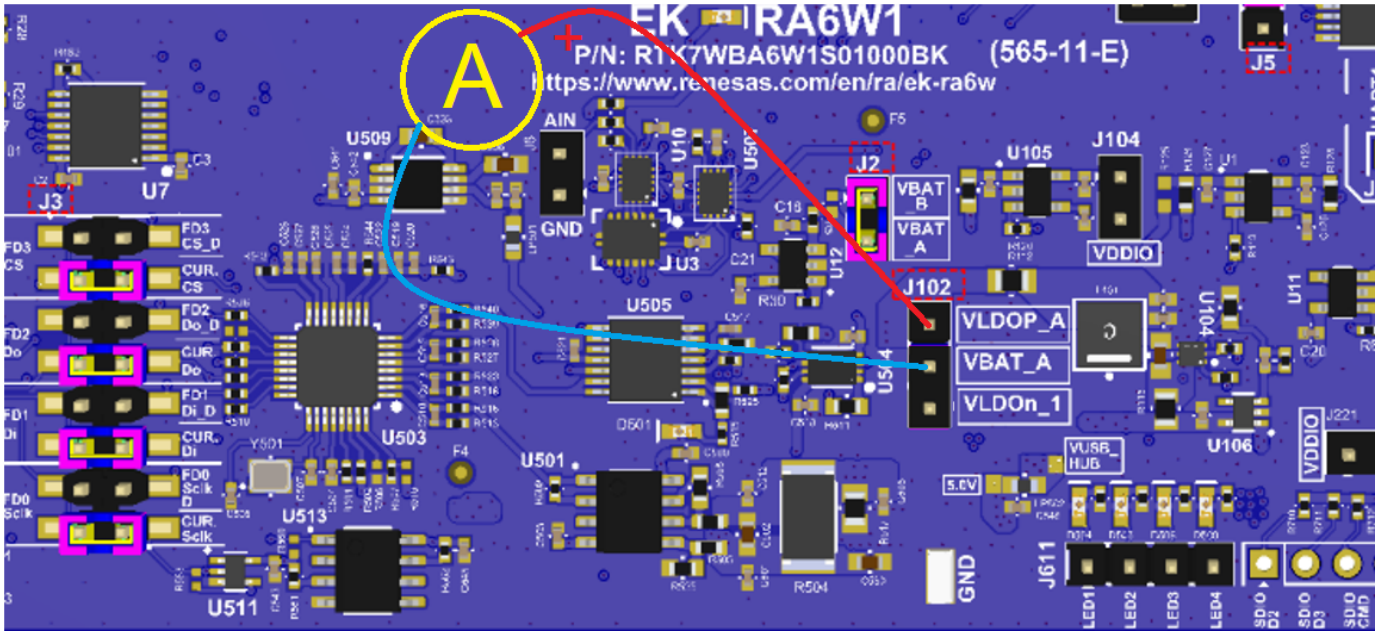

Figure 18. Hardware configuration for power measuring with external equipment

4.3.2 Case 2: Measure Power Consumption of the Wi-Fi Section in Combo Systems (Wi-Fi/Bluetooth LE)

You can measure the power consumption of the Wi-Fi Section on the Wi-Fi/Bluetooth LE systems on following evaluation boards/MCU or modules:

- RTK7WBA6W2S05000BK, RA6W2 MCU
- RTK7WBRQ61S03000BK, RRQ61051-008 module
- RTK7WBRQ61S04000BK, RRQ61051-009 module

You can perform the power measurement in one of the ways:

- Use on-board power measurement circuit:
 - a. Remove jumper from J2.
 - b. Connect a wire between J104 pin 1 and J2 pin 1.

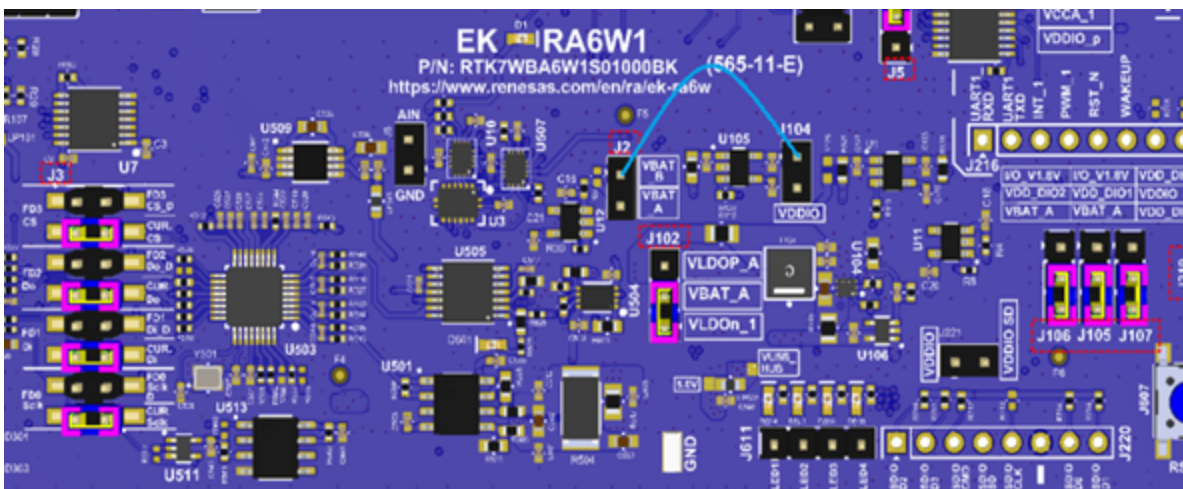

Figure 19. Hardware configuration for power measuring with on-board power measurement circuit

- Use external equipment:
 - a. Remove jumpers from J102 and J2.
 - b. Connect an amp-meter to J102 pins, VLDOP_A and VBAT_A.
 - c. Connect a wire between J104 pin 1 and J2 pin 1.

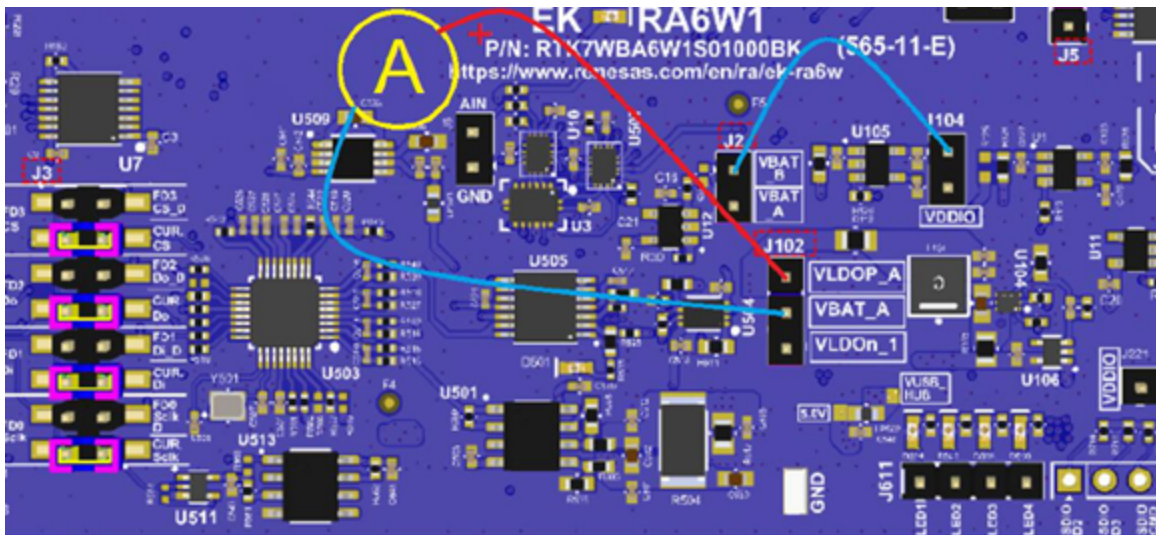

Figure 20. Hardware configuration for power measuring with external equipment

4.3.3 Case 3: Measure Power Consumption of Bluetooth LE Subsystem in Combo Systems (Wi-Fi/Bluetooth LE)

You can measure the power consumption of the Bluetooth LE section on the Wi-Fi/Bluetooth LE systems on following evaluation boards/MCU or modules:

- RTK7WBA6W2S05000BK, RA6W2 MCU
- RTK7WBRQ61S03000BK, RRQ61051-008 module
- RTK7WBRQ61S04000BK, RRQ61051-009 module

To perform the power measurement:

1. Remove jumper from J2.
2. Connect an amp-meter to J2 pins VBAT_A and VBAT_B.

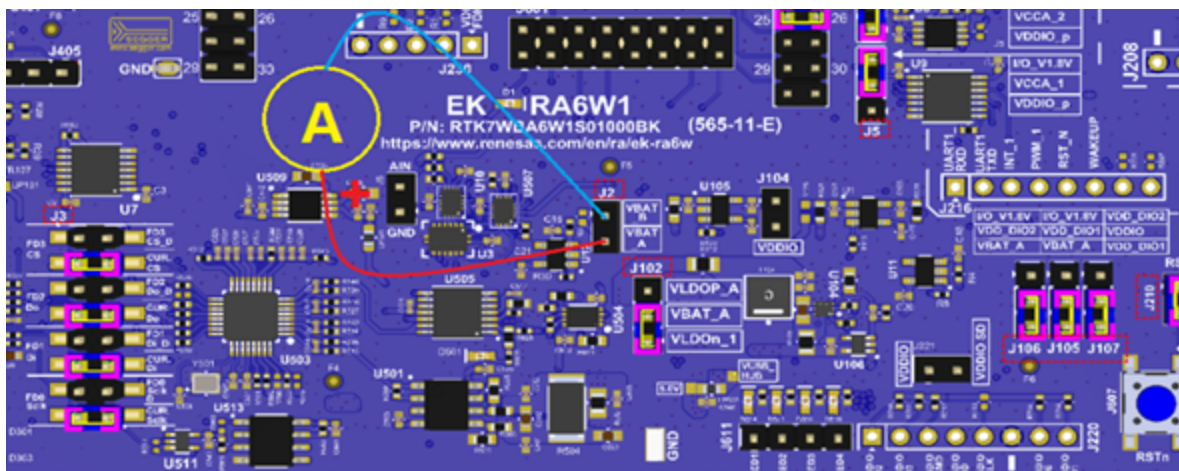

Figure 21. Hardware configuration for power measuring with external equipment

4.3.4 Case 4: Measure Power Consumption of the Wi-Fi and Bluetooth LE Sections in Combo Systems (Wi-Fi/Bluetooth LE)

You can measure the power consumption of the Wi-Fi and Bluetooth LE sections in Wi-Fi/Bluetooth LE systems on following evaluation boards/MCU or modules:

- RTK7WBA6W2S05000BK, RA6W2 MCU
- RTK7WBRQ61S03000BK, RRQ61051-008 module
- RTK7WBRQ61S04000BK, RRQ61051-009 module

You can perform the power measurement in one of the ways:

- Use on-board power measurement circuit:
 - a. Apply jumper on J2.
 - b. Apply jumper on J102 pin VLDOp_1 to J102, pin VBAT_A.

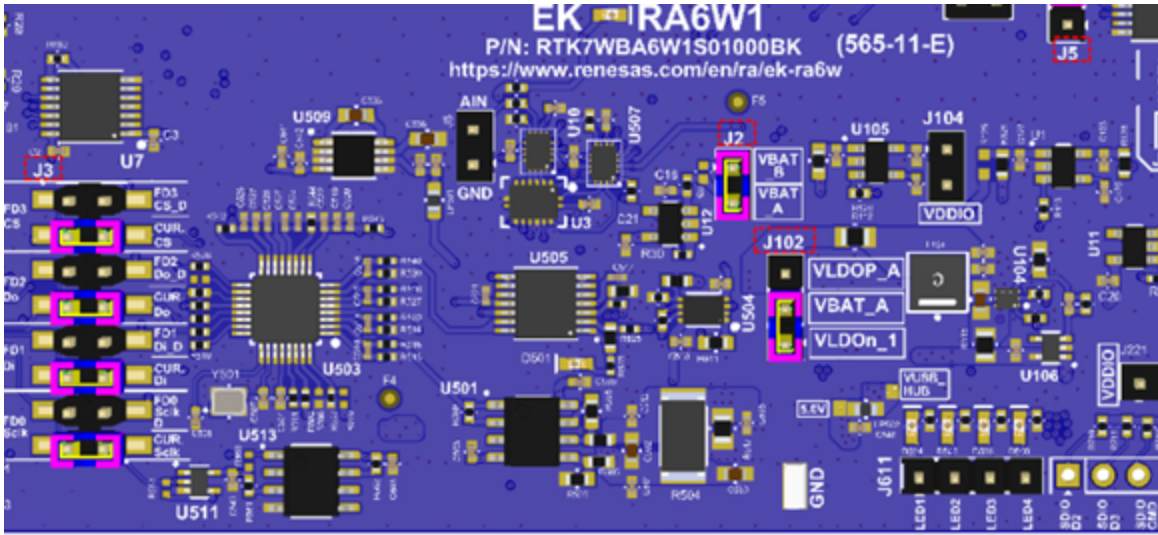

Figure 22. Hardware configuration for power measuring with power measurement circuit

- Use external equipment:
 - a. Remove jumper from J102.
 - b. Connect an Amp-meter to J102 pins VLDOp_A and VBAT_A.

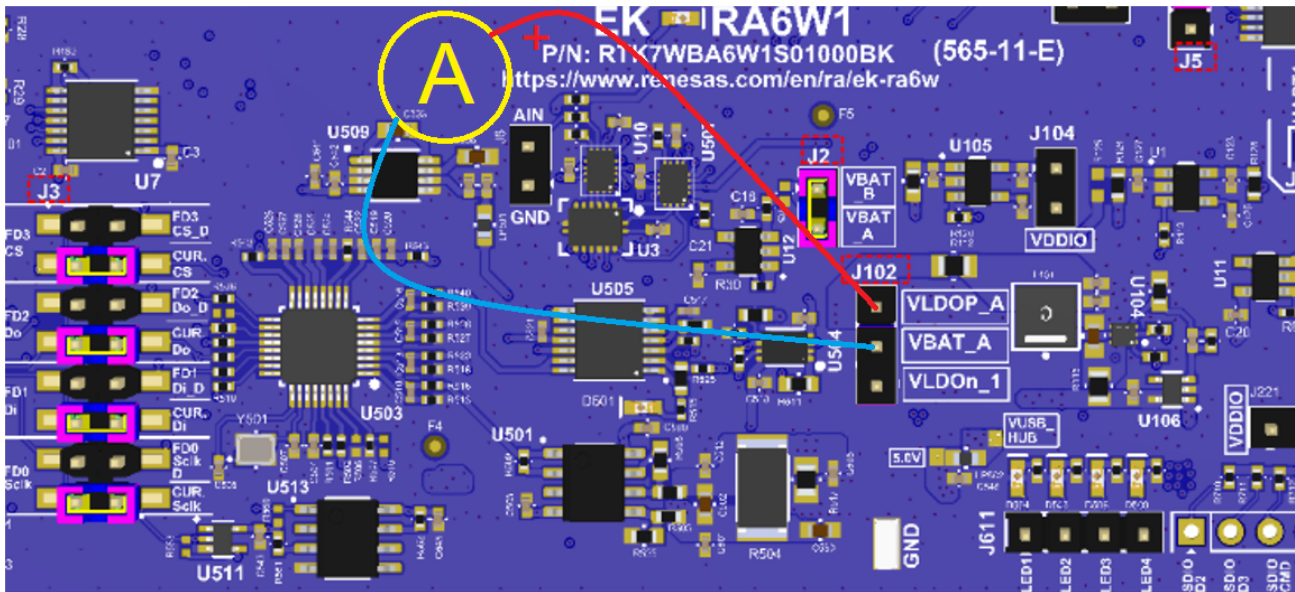

Figure 23. Hardware configuration for power measuring with external equipment

4.5 USB to UART (U302)

The USB to UART function is implemented by U302, FT2232HL (Figure 26). This chip is supplied with 3.3 V from U103 (Figure 27). A 12-MHz crystal (Y302) is required for the chip operation.

The U302 functions are the following:

- Connecting a PC to the UART ports established on daughterboards.
- The signals of a full UART can be connected through level translators to U302.
By default, P0_00 and P0_01 are assigned to UART0_TX and UART0_Rx through jumpers on J201, pins 1-2 and J201, pins 3-4. P0_00 and P0_01 are the booting UART of the Wi-Fi subsection.
- Connecting a PC to the power measurement circuit:
 - SPI connection with ADC (U503)
 - Up to eight triggers including software cursor triggering (TRIG_x).

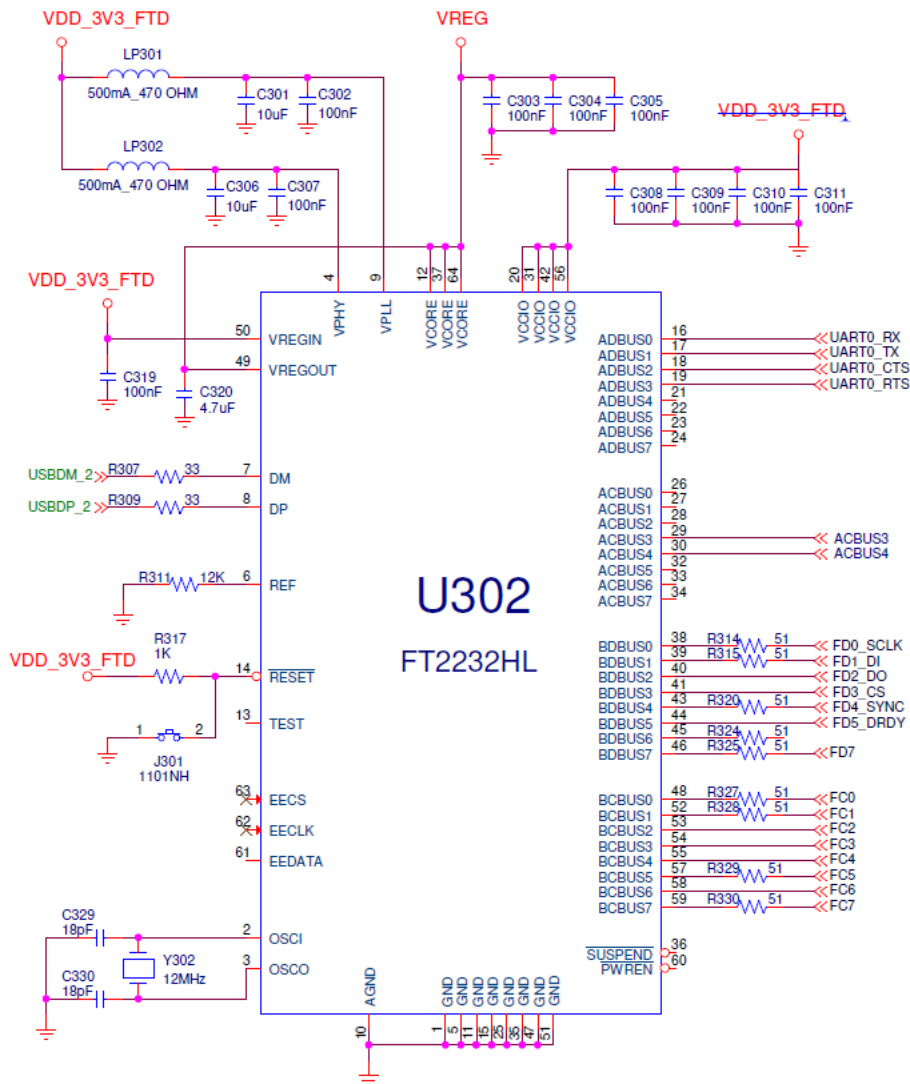

Figure 26. USB to UART circuitry

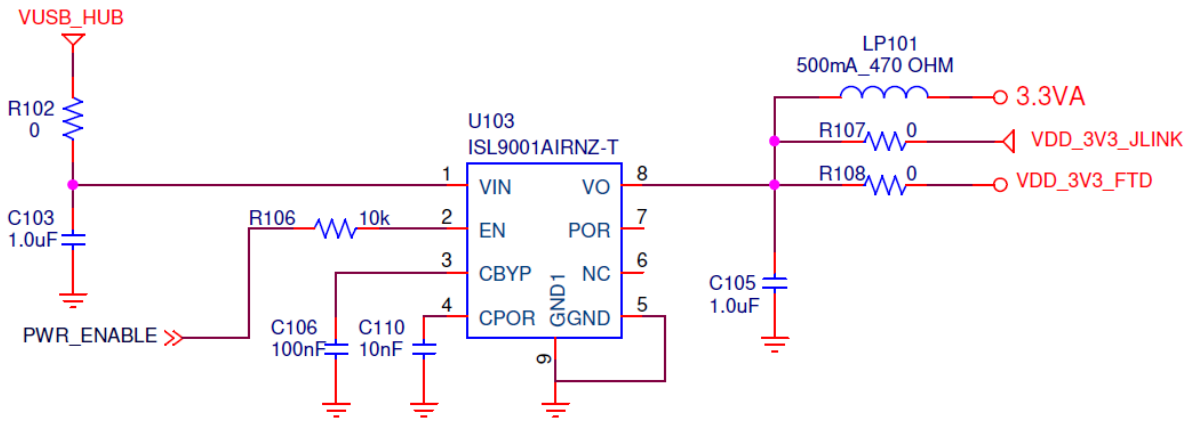

Figure 27. USB to UART power supply

4.6 USB to SWD/UART (U401)

The USB to SWD function is implemented by U401, R7FA4M2AB3CNE. Its operation is indicated through the green LED D402 on the EK-RA6W1 motherboard. This chip is supplied with 3.3 V from U103.

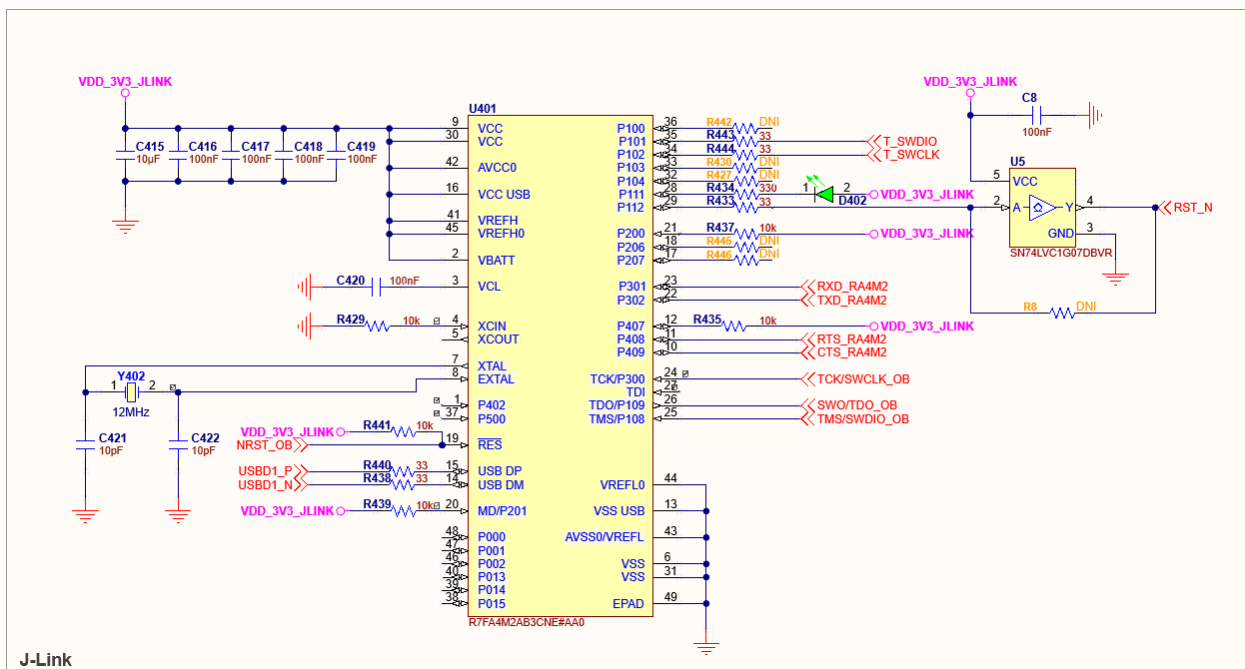

Figure 28. USB to JTAG/UART circuitry (U401) and UART header (J405)

The U401 functions are the following:

- Connecting a PC to SWD signals SWCLK, SWDIO of the Wi-Fi subsection. Jumpers must be connected on J203 pins 21-23 (C_SWCLK to SWCLK) and J203 pins 25-26 (C_SWKDIO to SWDIO). This is the default configuration, see [Figure 29](#).
- Connecting a PC to SWD signals SWCLK, SWDIO of the Bluetooth LE subsection (available in RA6W2 and RRQ61051 module). Jumpers must be connected on J203 pins 23-24, (B_P0_2_SWCLK to SWCLK) and J203 pins 27-28, (B_P0_10_SWKDIO to SWDIO). The signals on Bluetooth LE subsection must be connected to other signals.

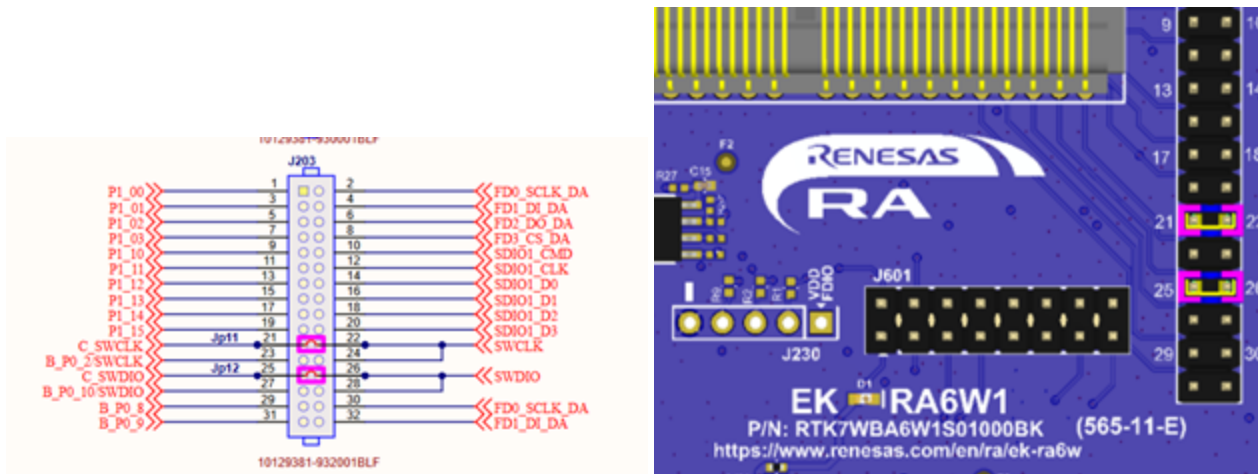

Figure 29. Default SWD connection to Wi-Fi subsection

- Connecting a PC to UART signals TXD_RA4M2, RXD_RA4M2, CTS_RA4M2, RTS_RATM2 (J405 - Header). The UART can be utilized by using jumping wires between J405 and UART interfaces of the daughterboards. https://kb.segger.com/Using_J-Link_VCOM_functionality#Hardware_flow_control

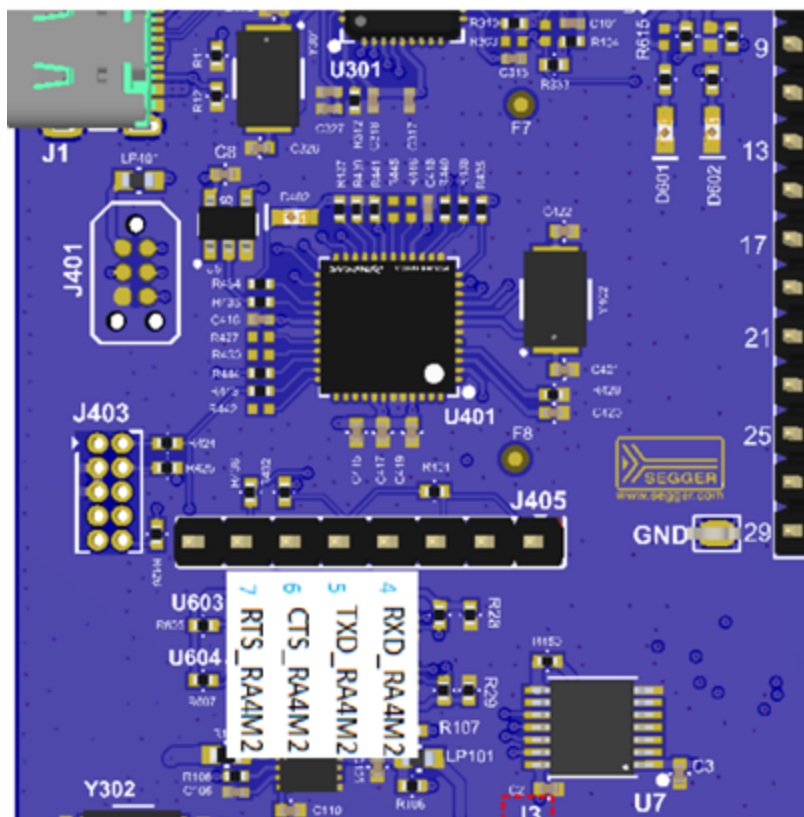

Figure 30. USB to SWD/UART circuitry – UART header, J405

NOTE

SWCLK and SWDRIO signals can be accessed on J403. J403 is used for EK-RA6W1 motherboard validation during production, and it must not be used in normal operation. Do not apply any external SWD signals on J403 because it causes conflict.

4.7 Level Translator

There are five level translators on EK-RA6W1 motherboard. They are applied on UART, SWD signals as well as the signals of interface section (PMOD, Arduino, and mikroBUS). The purpose of the level translators is to match the voltage levels of the GPIOs of RA6W1/RA6W2 to the ICs on motherboard. As the GPIOs can be supplied from VDD_DIO1 and VDD_DIO2, you must select the appropriate power supply for the translators. Figure 31 shows the block diagram of the level translators, and Figure 32 shows the electrical circuits. Table 7 shows the connectivity of level translators on the electrical circuit.

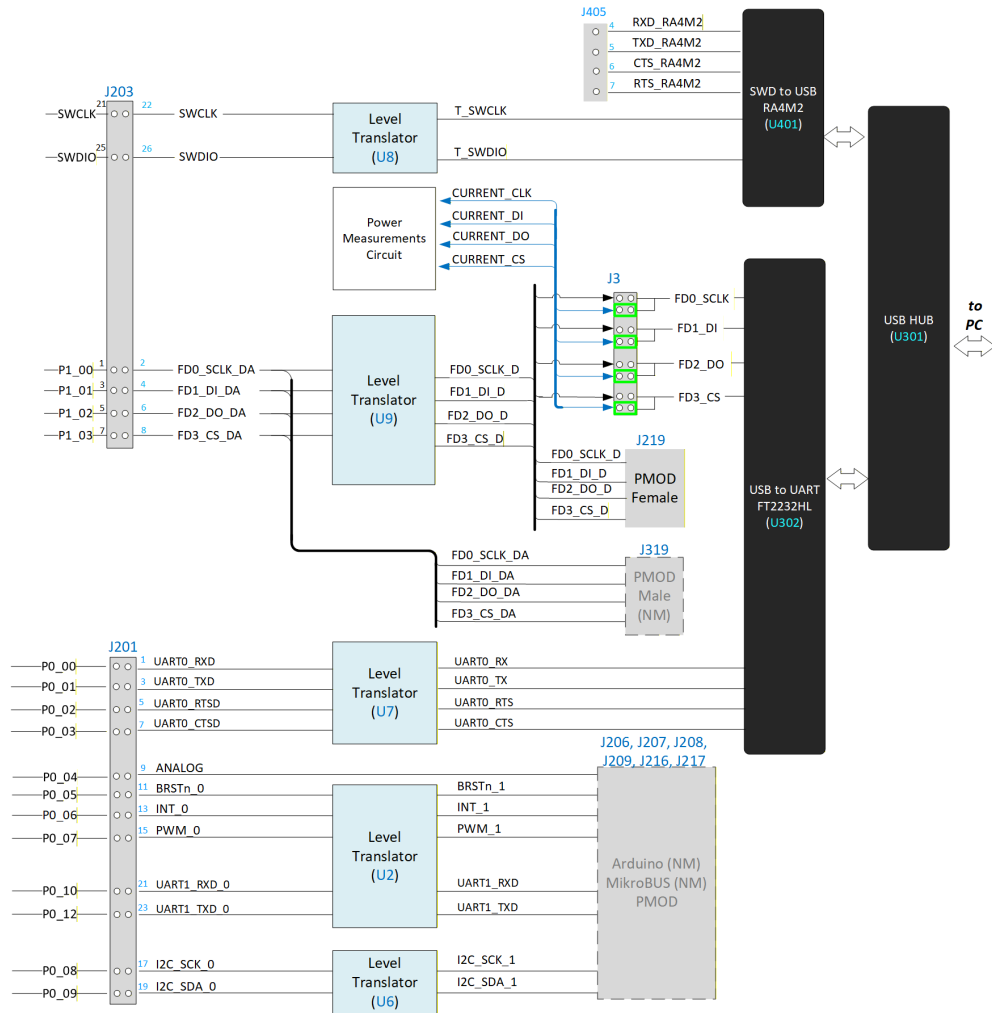

Figure 31. Level translators block diagram

Table 7. Connectivity of level translators

Part number	Side A Evaluation daughterboard		Side B EK-RA6W1 motherboard interfaces		
	Signal	Voltage A	Signal	Voltage B	Interface
U2	INT_0	VDD_DIO1	INT_1	VDDIO_p (= 3.3 V)	PMOD mikroBUS Arduino
	BRSTn_0		BRSTn		
	PWM_0		PWM_1		
	UART1_RXD_0		UART1_RXD		
	UART1_TXD_0		UART1_TXD		
U6	I2C_SCK_0	VDD_DIO1	I2C_SCK	VDDIO_p (= 3.3 V)	PMOD mikroBUS Arduino
	I2C_SDA_0		I2C_SDA		
U7	UART0_RXD	VBAT_A	UART0_Rx	VDD_3V3_ FTDI	UART0
	UART0_TXD		UART0_Tx		
	UART0_CTSD		UART0_Tx		
	UART0_RTSD		UART0_Tx		
U8	SWCLK	I/O_V1.8 V (= 1.8 V) or VDDIO_p (= 3.3 V)	T_SWCLK	VDD_3V3_ JLINK	SWD
	SWDIO		T_SWDIO		
U9	FD0_SCLK_D	I/O_V1.8 V (= 1.8 V) or VDDIO_p (= 3.3 V)	FD0_SCLK_ DA	VDDIO_p (= 3.3 V)	SPI
	FD1_DI_D		FD1_DI_DA		
	FD2_DO_D		FD2_DO_DA		
	FD3_CS_D		FD3_CS_DA		

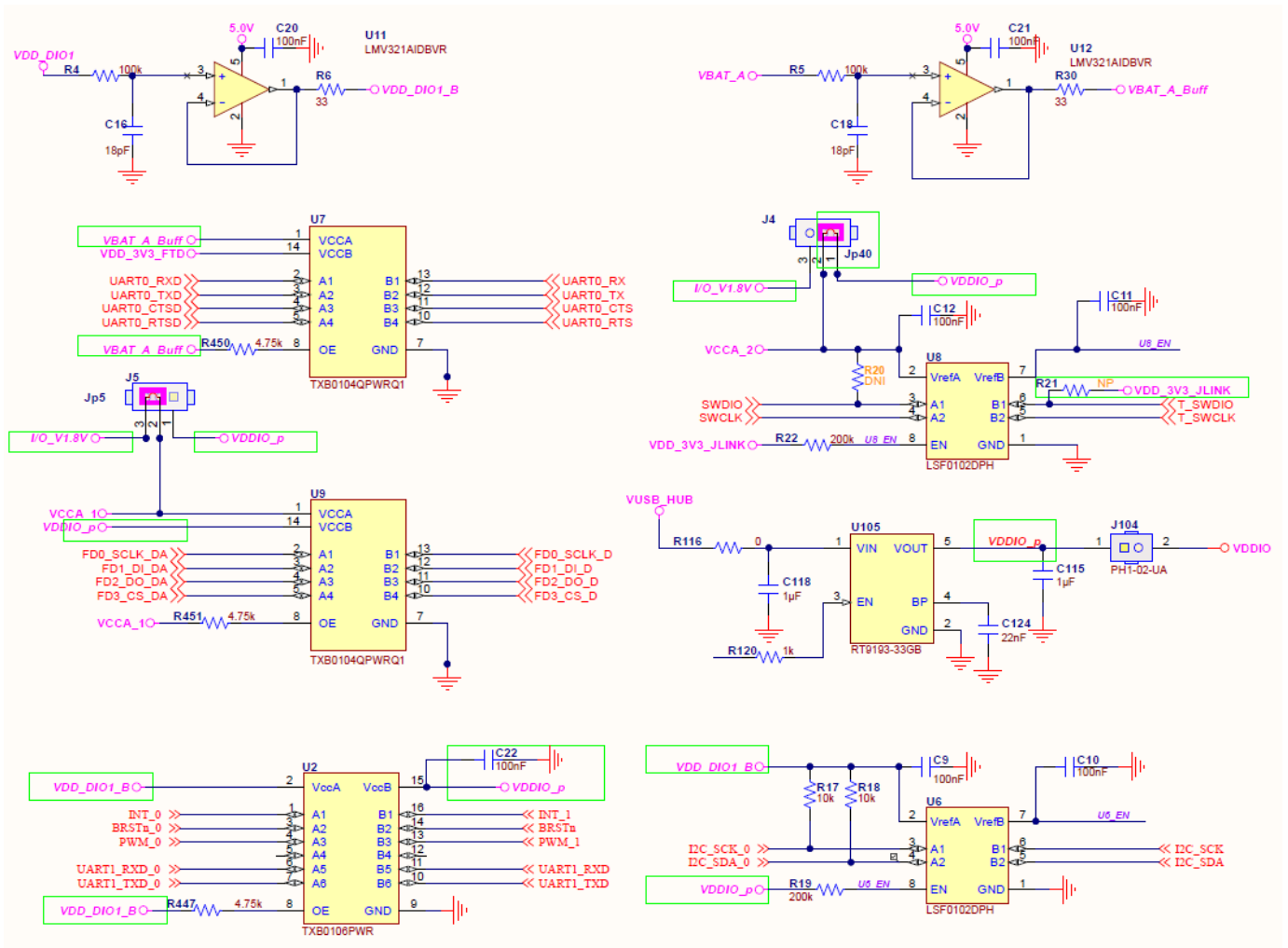

Figure 32. Voltage translator circuitry

VDDIO is a replica of VDD_DIO1/2, and it is generated from an operational amplifier (U108) configured as current buffer.

4.8 GPIOs and Breakout Headers J201/J203

All P0_x GPIOs from daughterboards are driven to the EK-RA6W1 motherboard for monitoring on the breakout header J201/J203. Figure 33 shows schematic of the J201/J203 and Figure 34 shows the position of the J201/J203 header on EK-RA6W1 motherboard.

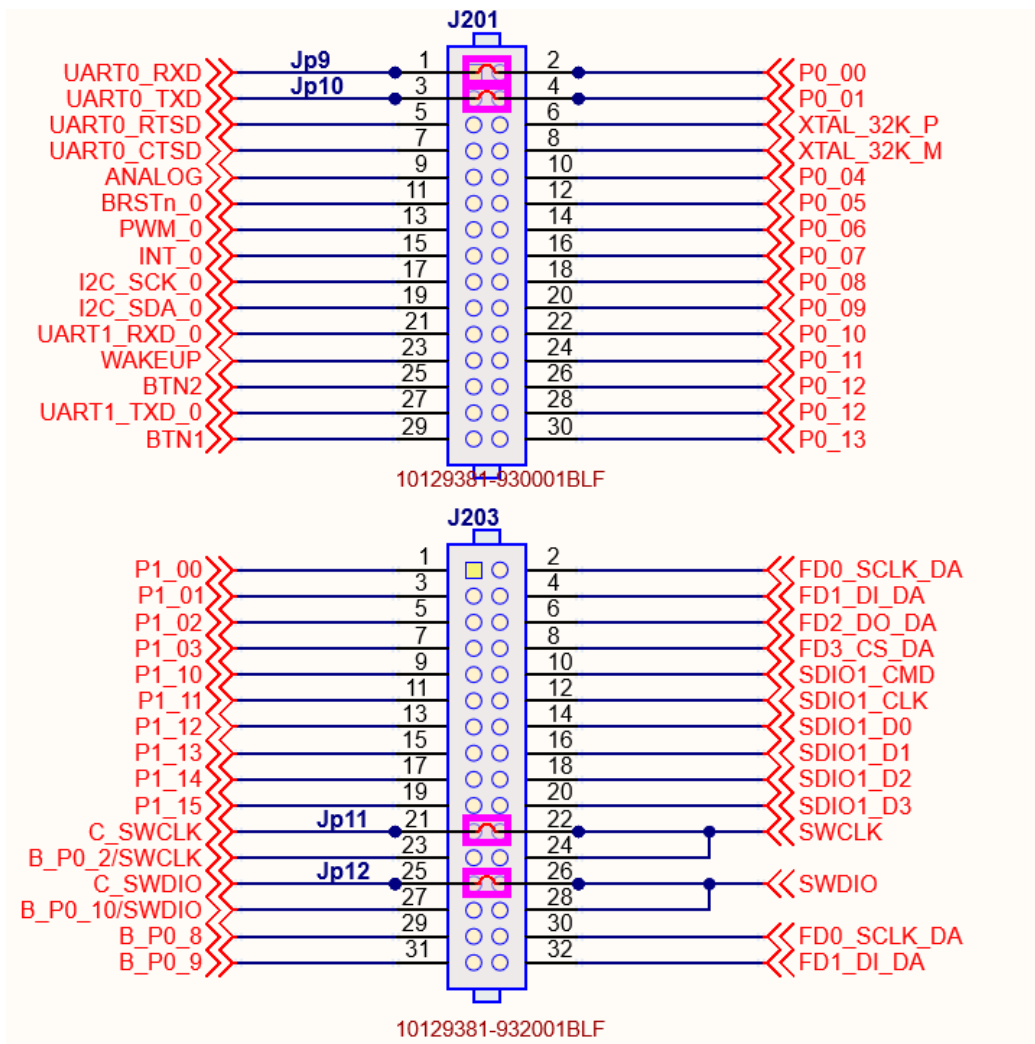

Figure 33. J201/J203 schematic

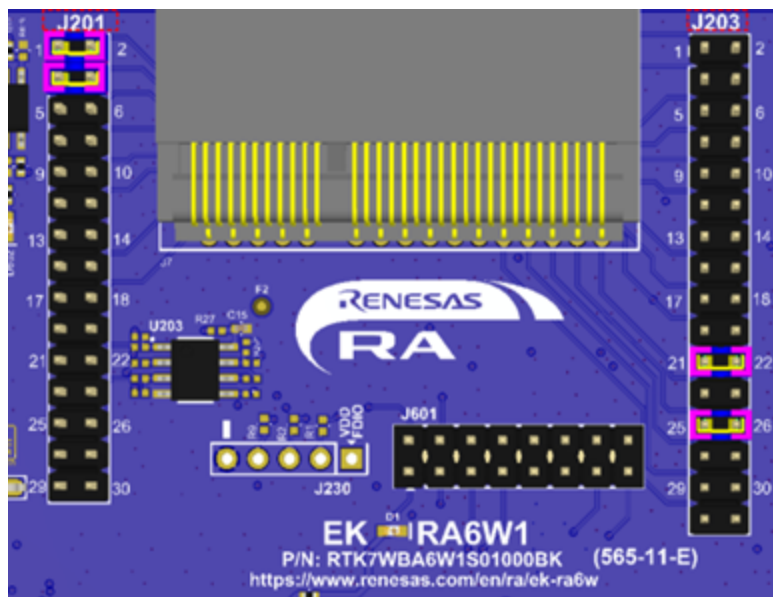

Figure 34. J201/J203 position on EK-RA6W1 motherboard

NOTE

On break-out headers, one row is assigned to the GPIOs of the daughterboards, whereas the other row is assigned to signals of the various interfaces, which are applied on the motherboard (SDIO, PSRAM, mikroBUS, PMOD and so on).

For activating the interfaces, connect the signals of the two rows with a jumper. The potential signals assignments of the EK-RA6W1 are shown in the following tables. More combinations can be achieved by using jumper wires.

Table 8. Signals connectivity Evaluation Kit for RA6W1, RA6W2 and RRQ61xx

Names of available signals	Subsystem	Power domain	POR default	Alternative usage 1	Pins assignments on EK-RA6W1 motherboard			
					RA6W1 daughterboard	RA6W2 daughterboard	RRQ61001-00x module daughterboard	RRQ61051-00x module daughterboard
B_P0_00	Bluetooth LE	VBAT_B	RST		Not Available	P1_10/URX (Wi-Fi)	Not Available	P1_10/URX (Wi-Fi)
B_P0_01	Bluetooth LE	VBAT_B	GPIO			P1_11/UTX (Wi-Fi)		P1_11/ UTX (Wi-Fi)
B_P0_02	Bluetooth LE	VBAT_B	SWCLK			P1_14/BLE_RST		P1_14/ BLE_RST
B_P0_03	Bluetooth LE	VBAT_B	GPIO			P1_12/UCTS (Wi-Fi)		P1_12/UCTS (Wi-Fi)
B_P0_04	Bluetooth LE	VBAT_B	GPIO			P1_13/URTS (Wi-Fi)		P1_13/URTS (Wi-Fi)
B_P0_05	Bluetooth LE	VBAT_B	GPIO			P1_15/Coex		P1_15/ Coex
B_P0_06	Bluetooth LE	VBAT_B	GPIO			Not Available		GPIO
B_P0_07	Bluetooth LE	VBAT_B	GPIO					GPIO
B_P0_08	Bluetooth LE	VBAT_B	GPIO					GPIO
B_P0_09	Bluetooth LE	VBAT_B	GPIO					GPIO
B_P0_10	Bluetooth LE	VBAT_B	SWDIO					GPIO
B_P0_11	Bluetooth LE	VBAT_B	GPIO					GPIO
RST_N	Wi-Fi	VBAT_A	RST_N		RST_N	RST_N	RST_N	RST_N
P0_00	Wi-Fi	VBAT_A	rtc_wup1		UART0_RXD	UART0_RXD	UART0_RXD	UART0_RXD
P0_01	Wi-Fi	VBAT_A	sen_out		UART0_TXD	UART0_TXD	UART0_TXD	UART0_TXD
P0_02	Wi-Fi	VBAT_A	xtal32k_m		UART0_RTSD	UART0_RTSD	UART0_RTSD	UART0_RTSD
P0_03	Wi-Fi	VBAT_A	xtal32k_p		UART0_CTSD	UART0_CTSD	UART0_CTSD	UART0_CTSD
P0_04	Wi-Fi	VDDIO_DIO1	GPIO		ANALOG	ANALOG	ANALOG	ANALOG
P0_05	Wi-Fi	VDDIO_DIO1	GPIO		BRSTn	BRSTn	BRSTn	BRSTn
P0_06	Wi-Fi	VDDIO_DIO1	GPIO		PWM_1	RFSW1	PWM_1	RFSW1
P0_07	Wi-Fi	VDDIO_DIO1	GPIO		INT1	RFSW2	INT1	RFSW2
P0_08	Wi-Fi	VDDIO_DIO1	GPIO	QSPIR_CLK	I2C_SCK	I2C_SCK	I2C_SCK	I2C_SCK

Table 9. Signals connectivity Evaluation Kit for RA6W1, RA6W2 and RRQ610xx (continued)

Names of available signals	Subsystem	Power domain	POR default	Alternative usage 1	Pins assignments on EK-RA6W1 Motherboard			
					RA6W1 daughterboard	RA6W2 daughterboard	RRQ61001-00x module daughterboard	RRQ61051-00x module daughterboard
P0_09	Wi-Fi	VDDIO_DIO1	GPIO	QSPIR_CS	I2C_SDA	I2C_SDA	I2C_SDA	I2C_SDA
P0_10	Wi-Fi	VDDIO_DIO1	GPIO	QSPIR_D0	BTN1	BTN1	BTN1	BTN1
P0_11	Wi-Fi		GPIO	QSPIR_D1	BTN2	BTN2	BTN2	BTN2
P0_12	Wi-Fi		GPIO	QSPIR_D2	WAKE_UP UART1_RXD	WAKE_UP UART1_RXD	WAKE_UP UART1_RXD	WAKE_UP UART1_RXD
P0_13	Wi-Fi	VDDIO_DIO1	GPIO	QSPIR_D3	UART1_TXD	UART1_TXD	UART1_TXD	UART1_TXD
P1_00	Wi-Fi	VDDIO_FDIO	GPIO		FD0_SCLK_DA	FD0_SCLK_DA	FD0_SCLK_DA	FD0_SCLK_DA
P1_01	Wi-Fi	VDDIO_FDIO	GPIO		FD1_DI_DA	FD1_DI_DA	FD1_DI_DA	FD1_DI_DA
P1_02	Wi-Fi	VDDIO_FDIO	GPIO		FD2_DO_DA	FD2_DO_DA	FD2_DO_DA	FD2_DO_DA
P1_03	Wi-Fi	VDDIO_FDIO	GPIO		FD3_CS_DA	FD3_CS_DA	FD3_CS_DA	FD3_CS_DA
P1_04	Wi-Fi	VDDIO_FDIO	GPIO		OQSPI_D0	OQSPI_D0	Connections applied internally to module. Not available on motherboard.	Connections applied internally to module. Not available on motherboard.
P1_05	Wi-Fi	VDDIO_FDIO	GPIO		OQSPI_D1	OQSPI_D1		
P1_06	Wi-Fi	VDDIO_FDIO	GPIO		OQSPI_D2	OQSPI_D2		
P1_07	Wi-Fi	VDDIO_FDIO	GPIO		OQSPI_D3	OQSPI_D3		
P1_08	Wi-Fi	VDDIO_FDIO	GPIO		OQSPI_CLK	OQSPI_CLK		
P1_09	Wi-Fi	VDDIO_FDIO	GPIO		OQSPI_CS	OQSPI_CS		
P1_10	Wi-Fi	VDDIO_DIO2	GPIO		SDIO1_CMD	B_P0_00/UTX (Bluetooth LE)	SDIO1_CMD	B_P0_00/UTX (Bluetooth LE)
P1_11	Wi-Fi	VDDIO_DIO2	GPIO		SDIO1_CLK	B_P0_01/URX (Bluetooth LE)	SDIO1_CLK	B_P0_01/URX (Bluetooth LE)
P1_12	Wi-Fi	VDDIO_DIO2	GPIO		SDIO1_D0	B_P0_03/URTS (Bluetooth LE)	SDIO1_D0	B_P0_03/URTS (Bluetooth LE)
P1_13	Wi-Fi	VDDIO_DIO2	GPIO		SDIO1_D1	B_P0_04/UCTS (Bluetooth LE)	SDIO1_D1	B_P0_04/UCTS (Bluetooth LE)
P1_14	Wi-Fi	VDDIO_DIO2	GPIO		SDIO1_D2	B_P0_02/BLE_RST	SDIO1_D2	B_P0_02/BLE_RST

Names of available signals	Subsystem	Power domain	POR default	Alternative usage 1	Pins assignments on EK-RA6W1 Motherboard			
					RA6W1 daughterboard	RA6W2 daughterboard	RRQ61001-00x module daughterboard	RRQ61051-00x module daughterboard
P1_15	Wi-Fi	VDDIO_DIO2	GPIO		SDIO1_D3	B_P0_05/Coex	SDIO1_D3	B_P0_05/Coex
P1_16	Wi-Fi	VDDIO_DIO2	SWCLK		SWCLK	SWCLK	SWCLK	SWCLK
P1_17	Wi-Fi	VDDIO_DIO2	SWDIO		SWDIO	SWDIO	SWDIO	SWDIO

4.8.1 Enable UART for Wi-Fi

To enable UART for Wi-Fi, use jumpers between P0_00 and P0_01 to UART0_RXD and UART0_TXD respectively.

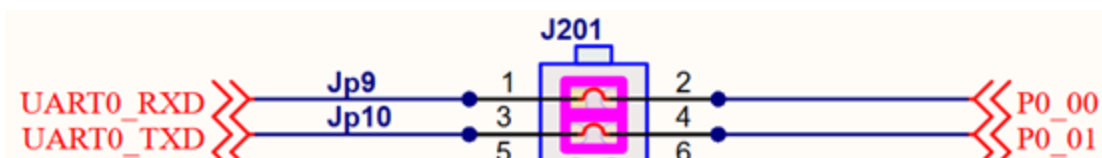

Figure 35. Enabling UART0 on motherboard

4.8.2 Enable SWD

Only one SWD interface can be enabled at a time, either Wi-Fi or Bluetooth LE.

To enable SWD for Wi-Fi, use jumpers between SWCLK and T_SWCLK as well as SWDIO and T_SWCLK on J203.

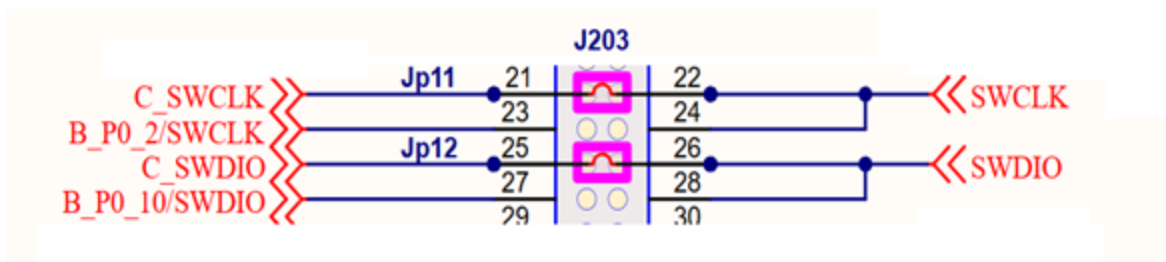

Figure 36. Enabling SWD for Wi-Fi (jumper settings on J203)

To enable SWD for Bluetooth LE, use jumpers between B_P0_2/SWCLK and T_SWCLK as well as between B_P0_10/SWDIO and T_SWCLK.

4.9 Push Buttons

There are four push buttons available on the EK-RA6W1 motherboard:

- J607 is assigned to RST_N
- J608 is assigned to WAKEUP
- J609 is reserved to BTN1
- J610 is reserved to BTN2.

By default, the jumpers on J210 are mounted. [Figure 37](#) shows the circuit schematic, [Figure 38](#) shows the position of the push buttons, and the position of the J210 header in PCB.

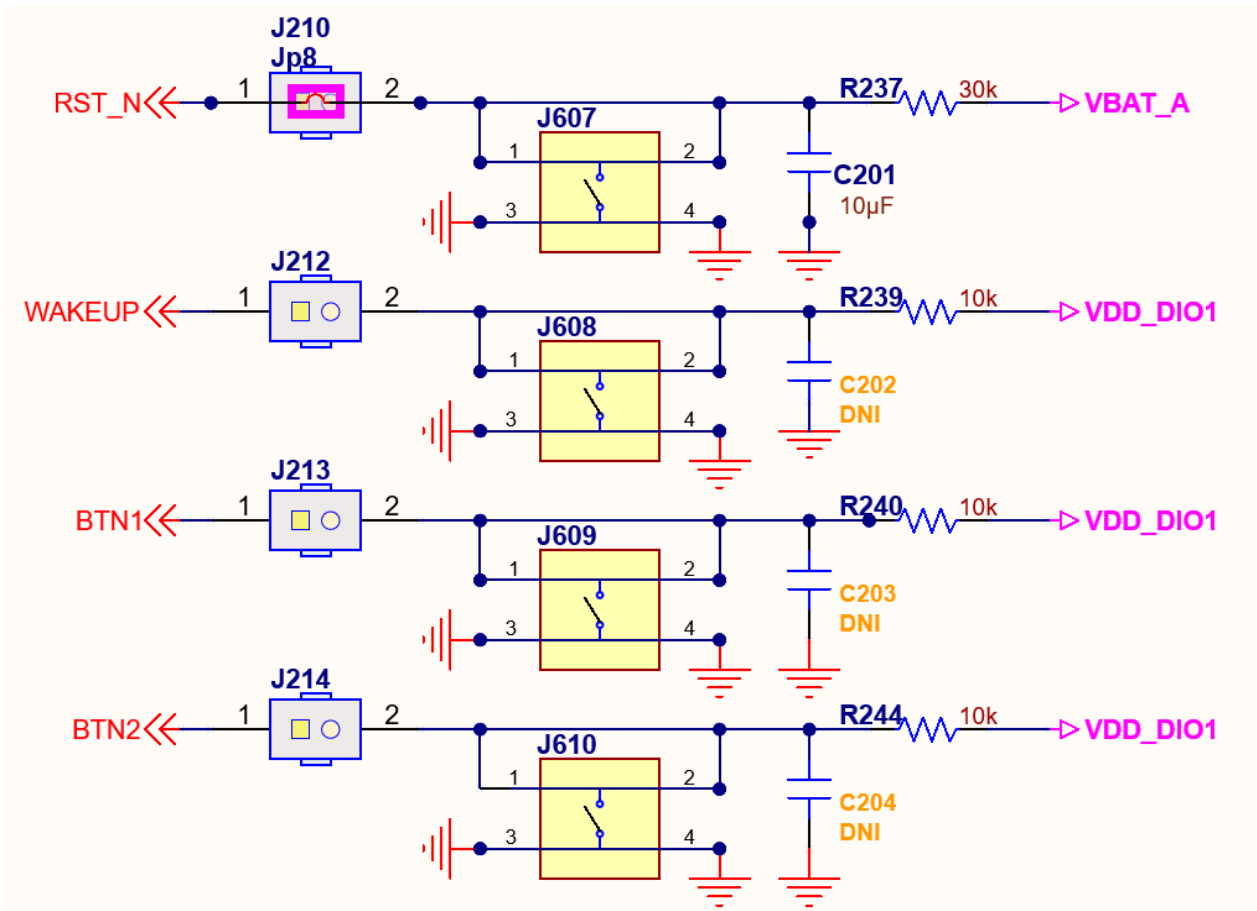

Figure 37. Push buttons J607/J608/J609/J610

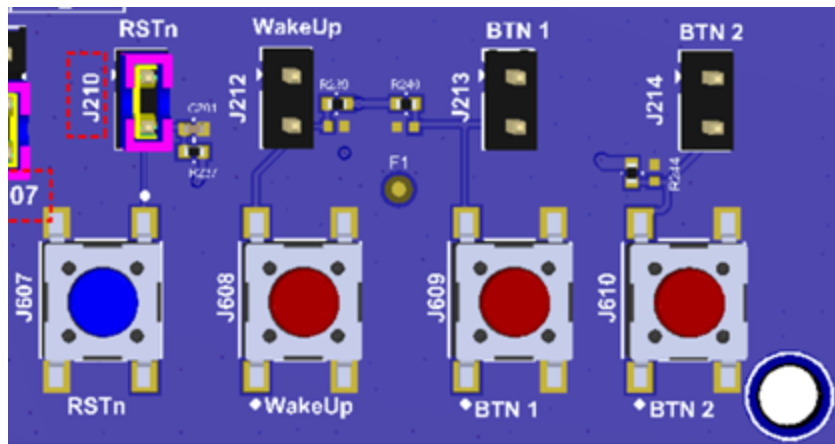

Figure 38. Push buttons position on the EK-RA6W1 motherboard

4.10 PSRAM Memory

In the EK-RA6W1 motherboard, a QSPI PSRAM (U203) option is available, not enabled by default. U203 is the APS6404L-SQRH-SNL, a 1.8 V, 64 Mbits PSRAM memory, connected to P0_09 to P0_13, (Wi-Fi subsystem) that is available to all daughterboards.

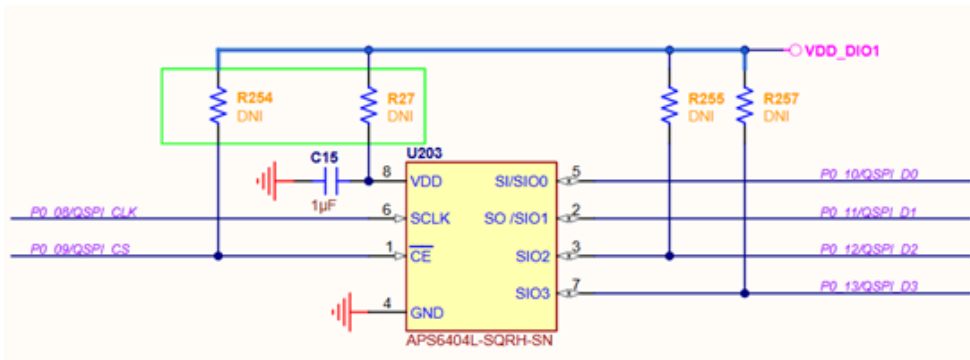

Figure 39. QSPI NOR Flash place holder on EK-RA6W1 motherboard

For enabling QSPI NOR Flash (U202), modify the hardware setup of both motherboard and daughterboard as shown in Table 10.

Table 10. Hardware modifications for enabling QSPI Flash (U202) on motherboard

Development board	Modifications	Schematic
EK-RA6W1 motherboard (565-11-x)	<p>Mount R27 = 0 (0402)</p> <p>Mount R254 = 10K (0402)</p> <p>Mount R247, R248, R249, R250, R256, and R258 with a 0-Ω Resistor (package 0402)</p>	



Figure 42. QSPI PSRAM (U203) on EK-RA6W1 motherboard

4.11 SDIO Interface

RA6W1 MCU and RA6W2 SiP provide SDIO interface (two alternative pin assignments, P0_08 to P0_13 and P1_10 to P1_15). On RA6W1 EVK motherboard, J220 is the header (not mounted) for SDIO1. SDIO1 is available on RA6W1 and RRQ61001 module daughterboards. For daughterboards of RA6W2 and RRQ61051 module, pins assignment of P1_10 to P1_15 is not available, as these pins are used for the Wi-Fi to Bluetooth LE communication. You can activate the SDIO interface by hardware modifications described in [Table 11](#).

Table 11. SDIO pin configuration

Signal	Pin assignment alternative 1	Pin assignment alternative 2	Description
SDIO_CMD	P1_10	P0_09	Command line
SDIO_CLK	P1_11	P0_08	Input serial clock
SDIO_D0	P1_12	P0_10	Bi-directional data line
SDIO_D1	P1_13	P0_11	Bi-directional data line
SDIO_D2	P1_14	P0_12	Bi-directional data line
SDIO_D3	P1_15	P0_13	Bi-directional data line

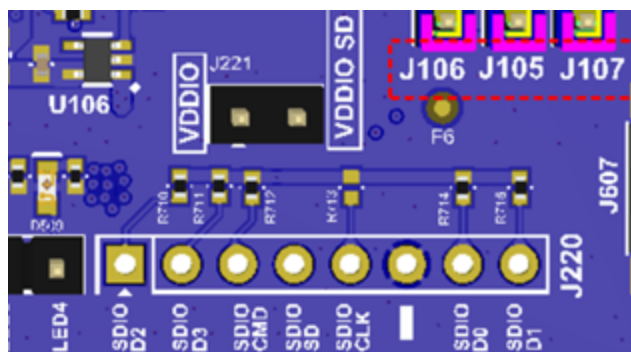
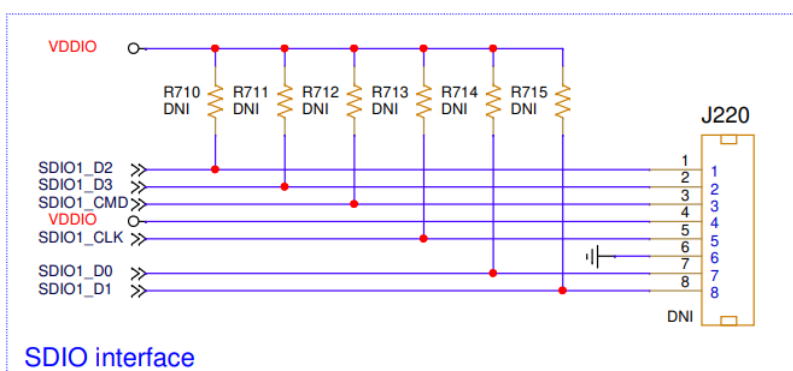

Figure 43. SDIO interface

SDIO connection between RA6W1, RA6W2, or RRQ610x1 EVKs and an external MPU or MCU is implemented through EK-RA6W1 motherboard and jumper wires, see [Figure 44](#).

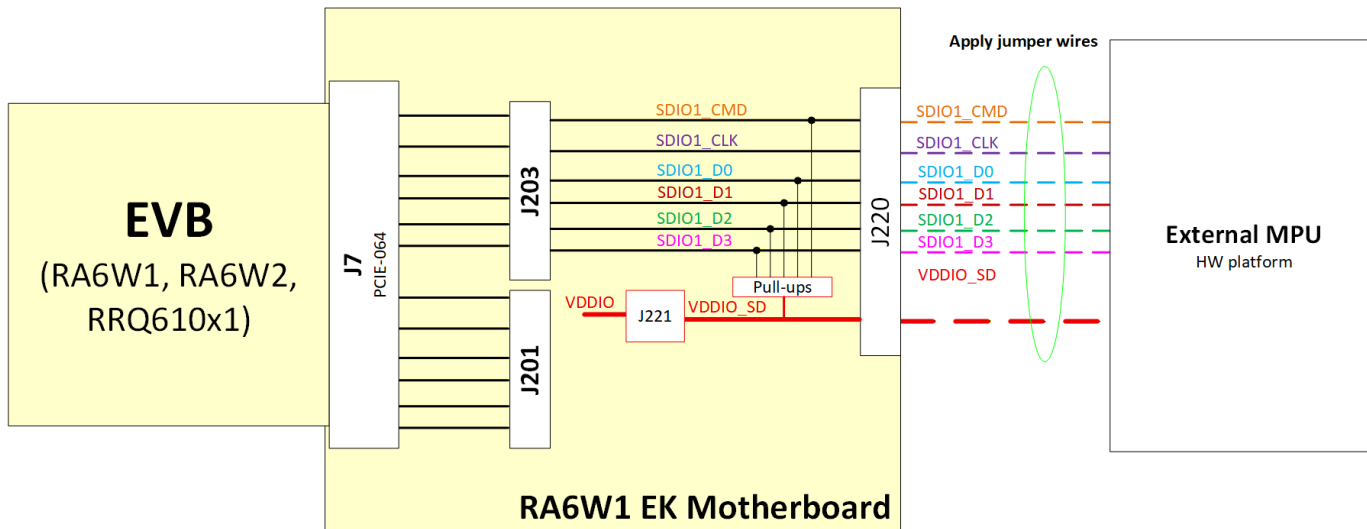

Figure 44. SDIO connection to an external MPU/MCU hardware platform

4.11.1 Configure SDIO

To enable GPIOs P1_10 to P1_15 for SDIO bus on EK-RA6W1, mount the following jumpers on J203:

- J203: 9-10
- J203: 11-12
- J203: 13-14
- J203: 15-16
- J203: 17-18
- J203: 19-20
- J220 must be mounted. Use a 1x8 single-row male header, 2.54 mm.
- J221: see VDDIO_SD power setting below

NOTE

Software modifications are also required.

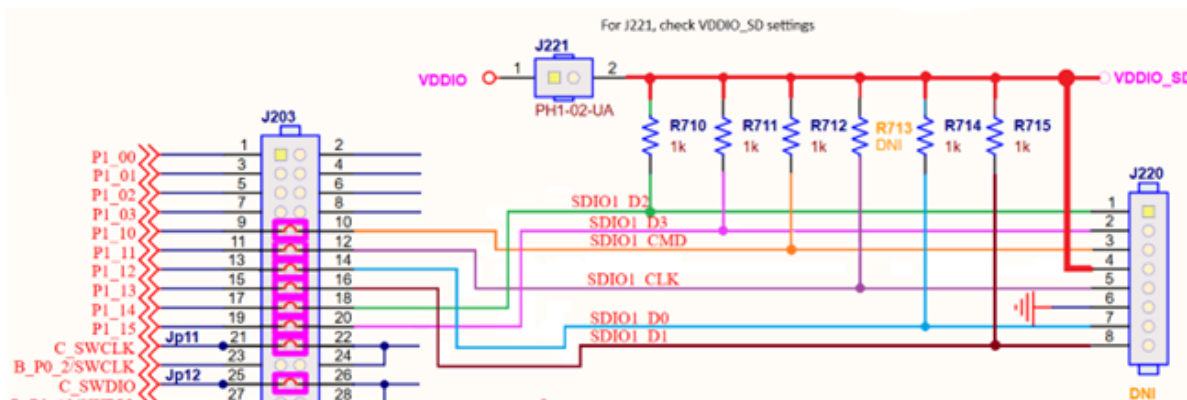

Figure 45. P1_10 to P1_15 assignment to SDIO

To enable GPIOs P0_8 to P0_13 for SDIO bus on EK-RA6W1, use the following jumper wires between J201 and J2:

- J203:10 to J201:20
- J203:12 to J201:18
- J203:14 to J201:22
- J203:16 to J201:24
- J203:18 to J201:26
- J203:20 to J201:30
- J220 must be mounted. Use a 1x8 single-row male header, 2.54 mm.
- J221: see VDDIO_SD power setting below

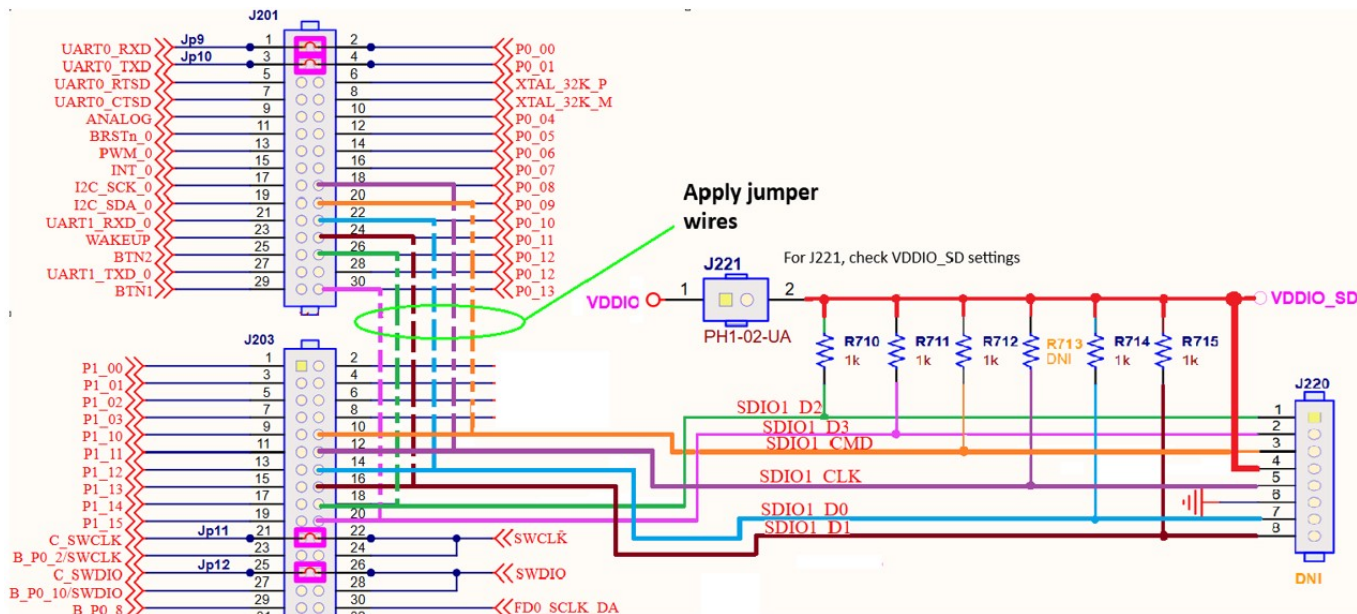

Figure 46. P0_8 to P0_13 for SDIO bus on EK-RA6W1

4.11.2 VDD_SDIO Power Setting

SDIO operation is not feasible without enabling the pull-ups for the data and command lines. As pull-ups are already placed on the EK-RA6W1 motherboard, you must only enable VDD_SDIO voltage rail. There are two cases, supplying VDD_SDIO from either the external MCU/MPC hardware platform or from the voltage generated on the EK-RA6W1 motherboard.

The SDIO signals use the same voltage range on both sides (EK-RA6W1 and external MCU/MPU hardware platform).

- Case 1: Supplying SDIO pull-ups from external MCU/MPU hardware platform
 - Connect VDDIO_SD to voltage pin (3.3 V) of external MPU/MCU platform through jumper wire
 - Do not apply jumper on J221

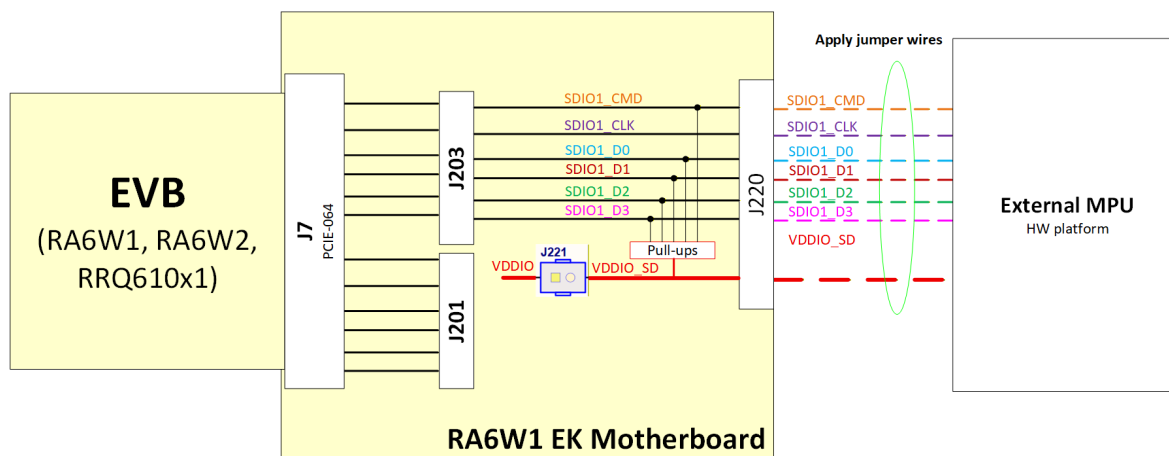

Figure 47. Supply SDIO pull-ups from external MCU/MPU hardware platform

- Case 2: Supplying SDIO pull-up from EK-RA6W1 motherboard:
 - Do not connect VDDIO_SD to voltage pin (3.3 V) of external MPU/MCU platform through jumper wire
 - Apply jumper on J221
 - VDDIO = 3.3 V

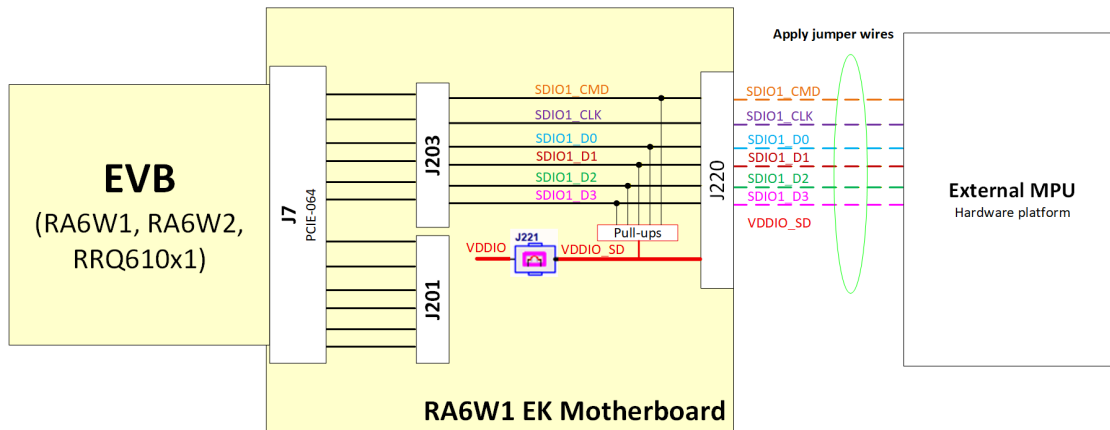

Figure 48. Supplying SDIO pull-up from EK-RA6W1 motherboard

4.12 MikroBUS Interface

The RA6W1 motherboard can support one mikroBUS module. The available slot is compatible with mikroBUS standard click boards for additional expandability requirements. Two female headers (8 position 0.100", through hole, socket type) are mounted (by default) on J208 and J209. Figure 49 shows the schematic circuit and Figure 50 shows the position of the mikroBUS slot.

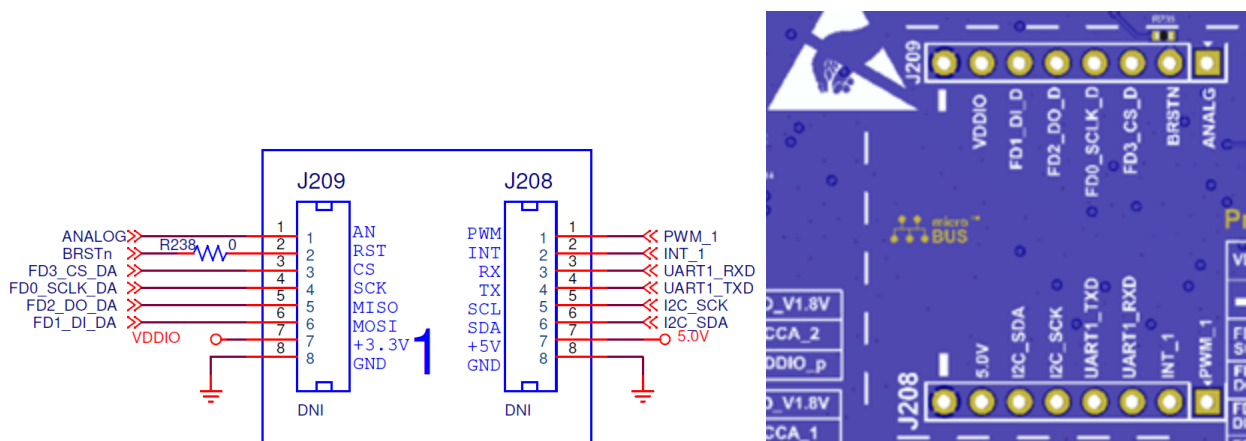

Figure 49. MikroBUS slot circuitry

To activate mikroBUS, connect the appropriate signals to GPIOs of daughterboard on headers J201 and/or J203.

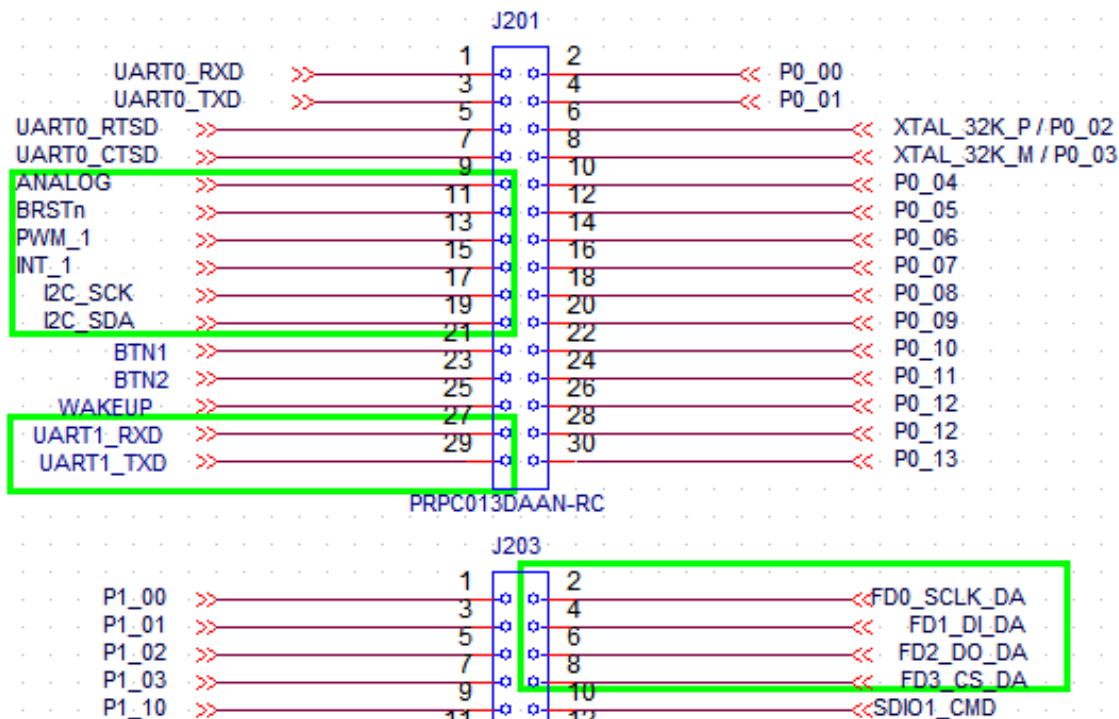

Figure 50. Enabling mikroBUS signals on the J201/J203 breakout headers

4.13 PMOD Interface

The EK-RA6W1 motherboard can support one PMOD module. The female header (J219) is mounted by default. Figure 51 shows the schematic circuit.

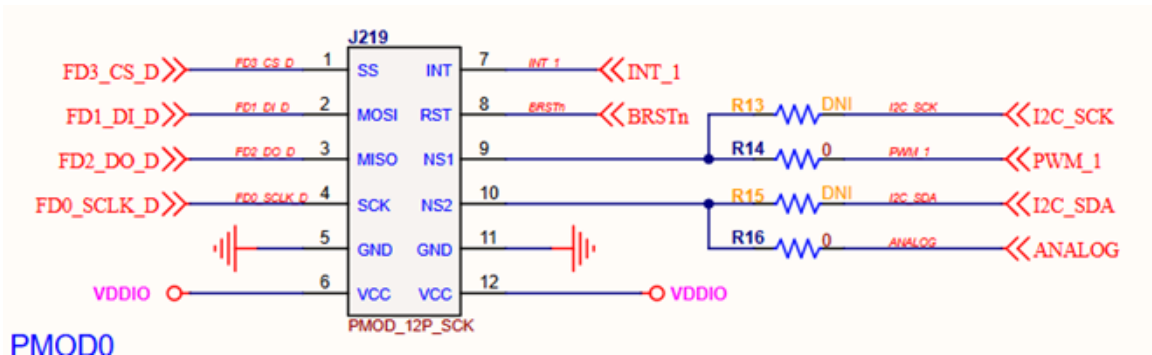

Figure 51. PMOD female connector (mounted) slot circuitry

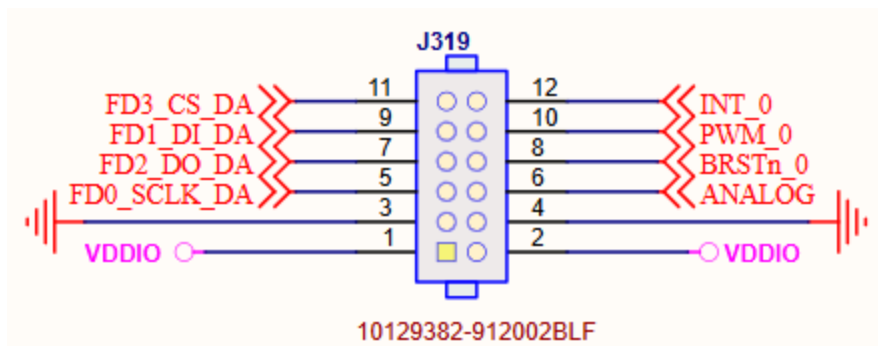

Figure 52. PMOD male connector (not mounted)

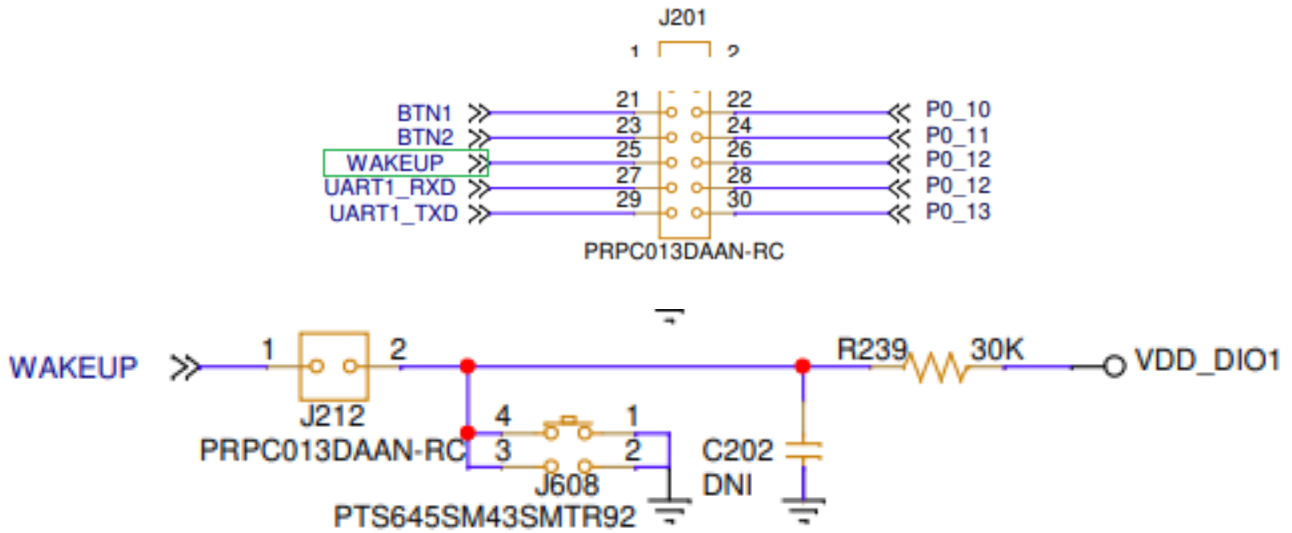

Figure 54. Wake-up function on EK-RA6W1 motherboard

4.15 LEDs

Four general-purpose LEDs are available on the EK-RA6W1 motherboard. They are connected to header J611, and they are green LEDs with 2.1 V voltage drop. Each LED is connected through 1 kΩ resistor to GND and for enabling it, a jump wire must be applied on J611 pin, see Figure 55.

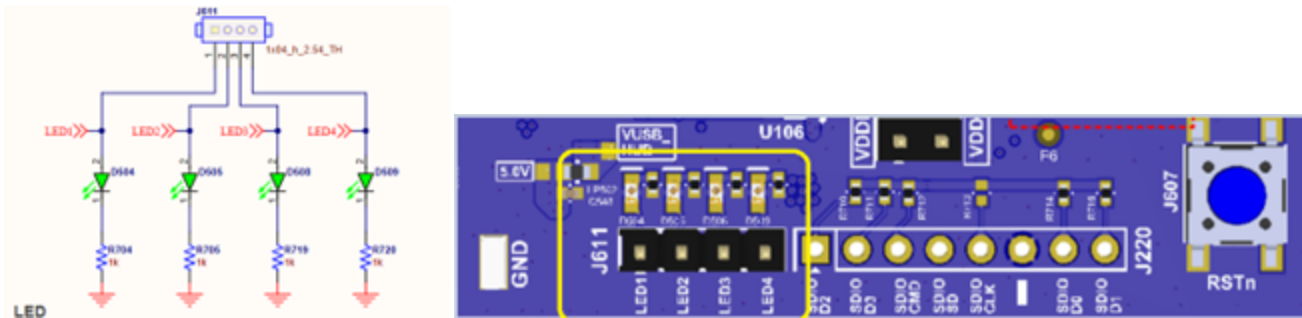

Figure 55. LEDs interface, circuit (left) and PCB location

5. RA6W1 QFN Evaluation Daughterboard (565-07-x) - RTK7WBA6W1S02000BK

RA6W1 MCU (U101): the RA6W1 is a highly integrated ultra-low power Wi-Fi MCU integrating an Arm® Cortex®-M33 system processor with a dual band 802.11a/b/g/n/ax Wi-Fi subsystem, on-chip memory, flexible peripheral interfaces, and power management features.

On the RA6W1 daughterboard with board number 565-07-x, the WLCSP package of RA6W1 is applied as well as all necessary components required for the system setup. The daughterboard, accompanied by the Motherboard, provides the capabilities for RA6W1 system evaluation and development.

The block diagram and the actual component locations of the RA6W1 daughterboard are shown in [Figure 56](#) and [Figure 57](#).

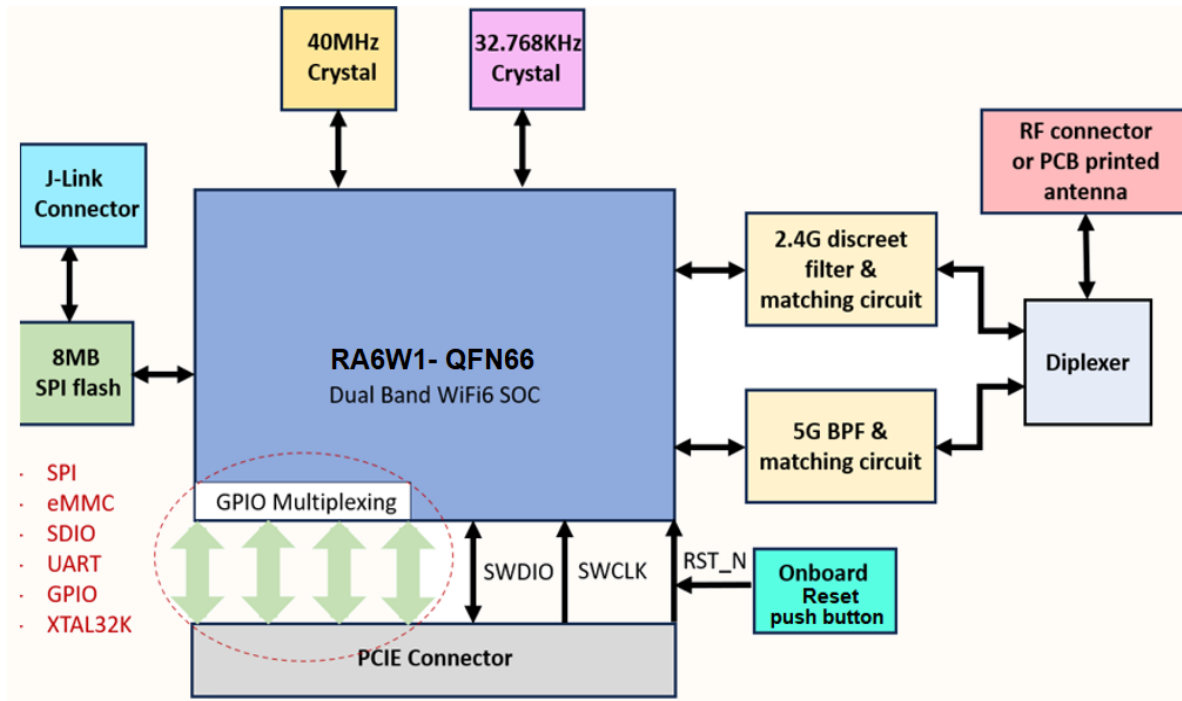

Figure 56. System block diagram of RA6W1 daughterboard

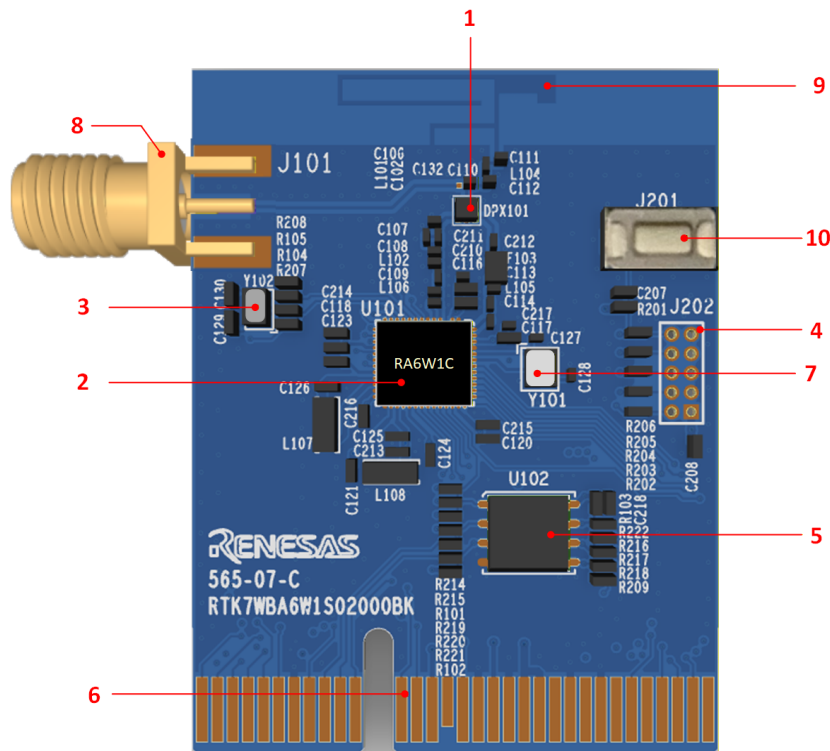

Figure 57. RA6W1 daughterboard component’s placement

Table 13. RA6W1 daughterboard part numbers and description

No	Name	Location
1	Antenna selection network	
2	RA6W1 MCU	U101
3	32.768 kHz XTAL	Y102
4	J-Link connector for QSPI NOR Flash programming	J202
5	QSPI NOR Flash	U102
6	PCIE interface connector with RA6W1	
7	40 MHz XTAL	Y101
8	SMA RF connector	J101
9	PCB printed antenna	
10	Onboard reset button	J201

5.1 RA6W1 GPIOs and Interface to Motherboard

RA6W1 MCU provides 26 GPIOs (including SWD signals). All GPIOs are available to motherboard through PCIE-64, PCB connector (U202).

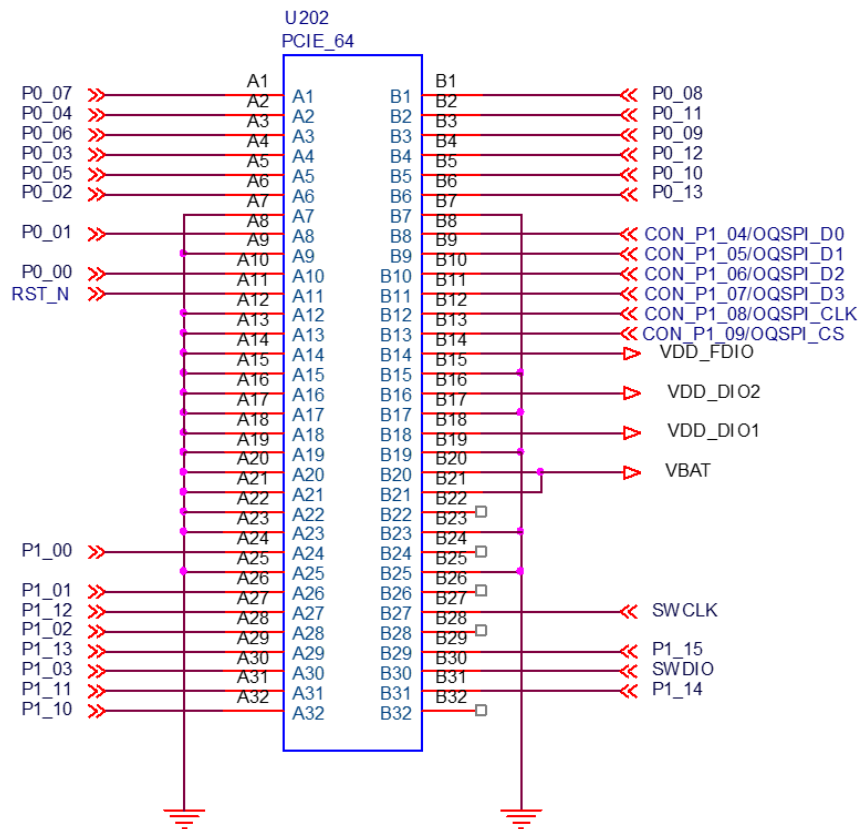
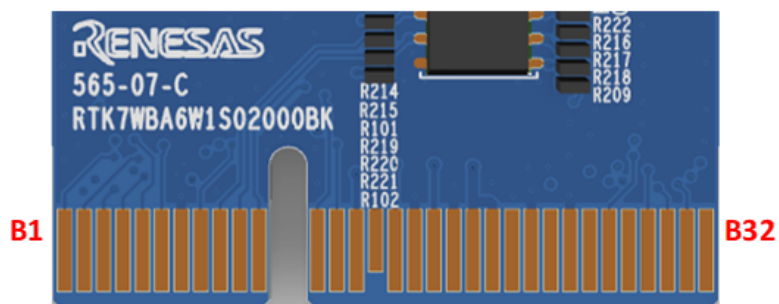

Figure 58. RA6W1 interface to Motherboard, Schematic

TOP VIEW



BOTTOM VIEW

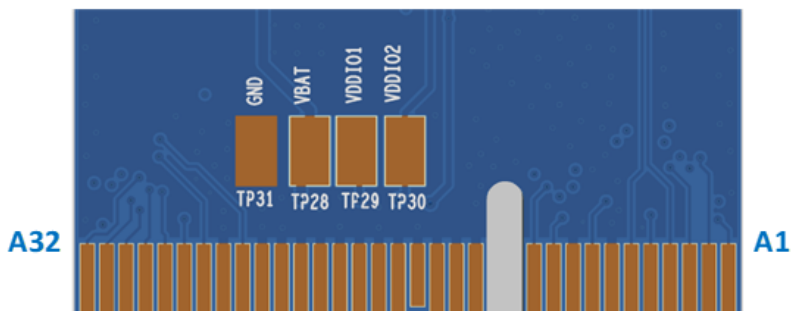

Figure 59. RA6W1 interface to motherboard PCB

Table 14. Pins assignment forRRQ61001 daughterboard

Pins	Section	PWR domain	Access	Connection
RST_N	Wi-Fi	VBAT	U202, Pin A11	
P0_00	Wi-Fi	VBAT	U202, Pin A10	
P0_01	Wi-Fi	VBAT	U202, Pin A8	
P0_02	Wi-Fi	VBAT	U202, Pin A6	32 kHz crystal
P0_03	Wi-Fi	VBAT	U202, Pin A4	32 kHz crystal
P0_04	Wi-Fi	VDDIO_DIO1	U202, Pin A2	
P0_05	Wi-Fi	VDDIO_DIO1	U202, Pin A5	
P0_06	Wi-Fi	VDDIO_DIO1	U202, Pin A3	
P0_07	Wi-Fi	VDDIO_DIO1	U202, Pin A1	
P0_08	Wi-Fi	VDDIO_DIO1	U202, Pin B1	
P0_09	Wi-Fi	VDDIO_DIO1	U202, Pin B3	
P0_10	Wi-Fi	VDDIO_DIO1	U202, Pin B5	
P0_11	Wi-Fi	VDDIO_DIO1	U202, Pin B2	
P0_12	Wi-Fi	VDDIO_DIO1	U202, Pin B4	
P0_13	Wi-Fi	VDDIO_DIO1	U202, Pin B6	
P1_00	Wi-Fi	VDDIO_FDIO=1.8 V	U202, Pin A24	
P1_01	Wi-Fi	VDDIO_FDIO=1.8 V	U202, Pin A26	
P1_02	Wi-Fi	VDDIO_FDIO=1.8 V	U202, Pin A28	
P1_03	Wi-Fi	VDDIO_FDIO=1.8 V	U202, Pin A30	
P1_04	Wi-Fi	VDDIO_FDIO=1.8 V	U202, Pin B8	Connected to U202 through R209 (Not Mounted). Assigned to OQSPI_D0
P1_05	Wi-Fi	VDDIO_FDIO=1.8 V	U202, Pin B9	Connected to U202 through R203 (Not Mounted). Assigned to OQSPI_D1
P1_06	Wi-Fi	VDDIO_FDIO=1.8 V	U202, Pin B10	Connected to U202 through R204 (Not Mounted). Assigned to OQSPI_D2
P1_07	Wi-Fi	VDDIO_FDIO=1.8 V	U202, Pin B11	Connected to U202 through R205 (Not Mounted). Assigned to OQSPI_D3
P1_08	Wi-Fi	VDDIO_FDIO=1.8 V	U202, Pin B12	Connected to U202 through R206 (Not Mounted). Assigned to OQSPI_CLK
P1_09	Wi-Fi	VDDIO_FDIO=1.8 V	U202, Pin B13	Connected to U202 through R202 (Not Mounted). Assigned to OQSPI_CS
P1_10	Wi-Fi	VDDIO_DIO2	U202, Pin A32	
P1_11	Wi-Fi	VDDIO_DIO2	U202, Pin A31	
P1_12	Wi-Fi	VDDIO_DIO2	U202, Pin A27	
P1_13	Wi-Fi	VDDIO_DIO2	U202, Pin A29	
P1_14	Wi-Fi	VDDIO_DIO2	U202, Pin B31	
P1_15	Wi-Fi	VDDIO_DIO2	U202, Pin B29	
P1_16	Wi-Fi	VDDIO_DIO2	U202, Pin B27	SWCLK
P1_17	Wi-Fi	VDDIO_DIO2	U202, Pin B30	SWDIO

5.2 Reset

Push-button J201 is used for resetting RA6W1. You can enable Reset also from button J607 on motherboard, see [Section 1.8 Push-buttons](#).

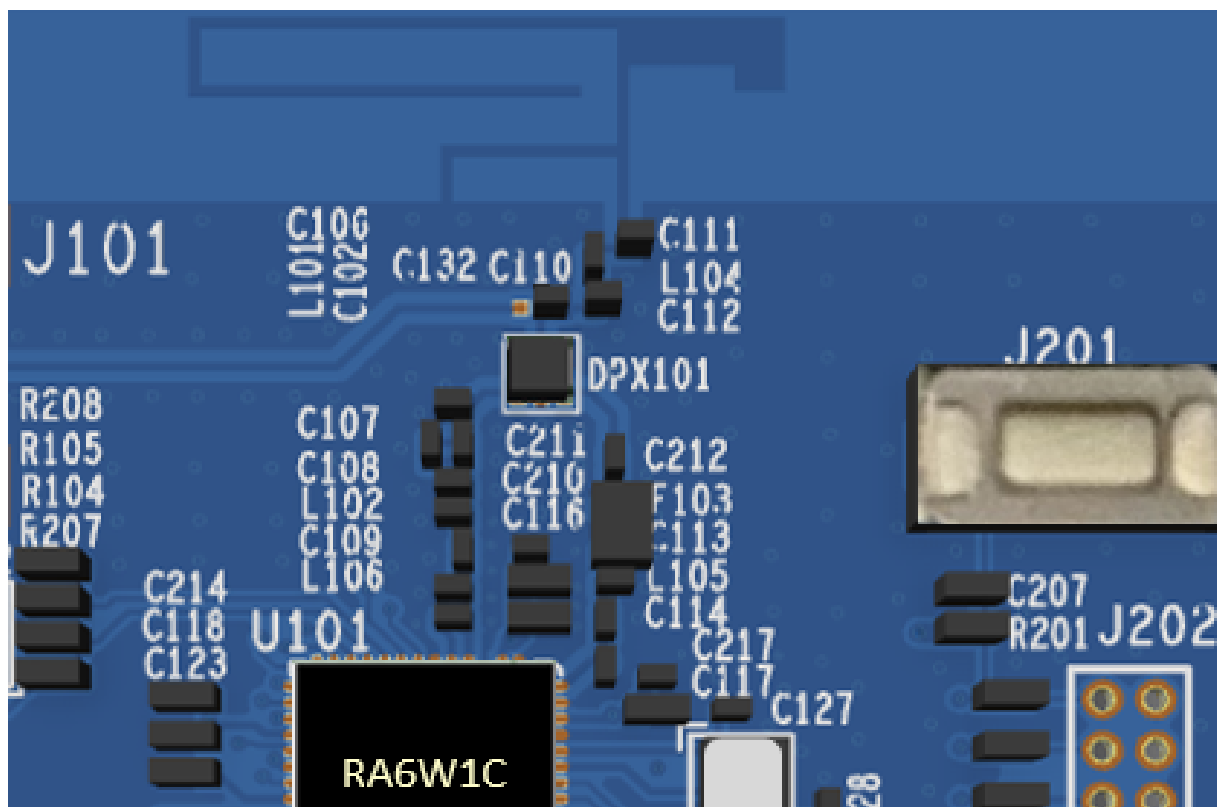
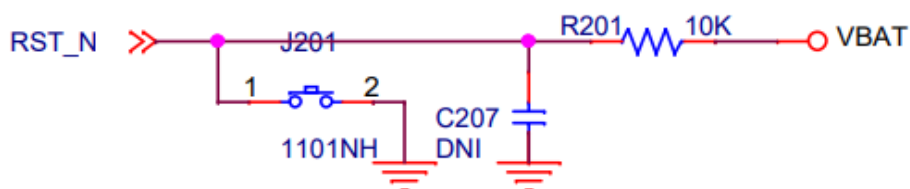

Figure 60. Reset Button (J201) on RA6W1 daughterboard

5.3 Clocks

- **40MHz XTAL (Y101):** the main clock of RA6W1 MCU is generated from a 40 MHz XTAL which is connected to the internal clock oscillator. The selected crystal is the CX2016DB40000D0FLJCC of [KYOCERA AVX](#).
- **32.768KHz XTAL (Y102):** for applications with more demanding accuracy/drift characteristics, such as timekeeping, using an external 32.768 kHz crystal is a suitable solution and the selected crystal is the FC-12M 32.7680KA-A5 of EPSON timing. By default, the external 32.768 kHz crystal is assembled on RA6W1. 32.768 kHz is connected to RA6W1 through P0_02 (XTAL32K_M) and P0_03 (XTAL32K_P).

5.4 QSPI NOR Flash

The component used is the Renesas AT25SL641-MHE-T or AT25SL641C-MHE-T. By default, the QSPI Flash (U102) is mounted on the daughterboard. QSPI NOR Flash is connected to the OQSPI bus of RA6W1, and it operates in eXecution in Place (XiP) mode. The Flash can be programmed directly from the 1.27 mm pitch header (J202). Header is connected through Not Mounted resistors.

QSPI bus is connected to the PCIE connector through Not Mounted resistors (R202 to R206 and R209). By default, QSPI bus is not available to the motherboard.

QSPI NOR Flash is supplied from VDD_FDIO = 1.8 V, which is generated from the RA6W1 SiP. Operating frequency is equal to 80 MHz.

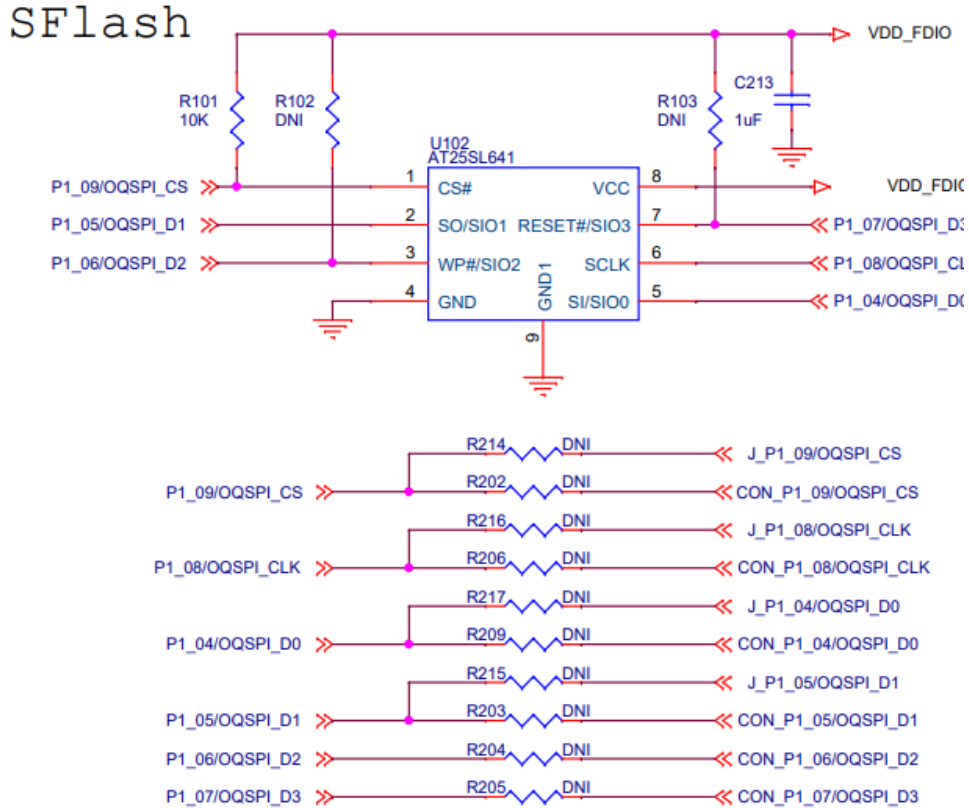

Figure 61. QSPI-Flash circuitry on RA6W1 daughterboard

A J-link connector (J202) for programming QSPI flash directly, is available on the RA6W1 Daughterboard. It utilizes SPI bus. You must mount the header J202 and resistors R214 to R217 (0 Ω).

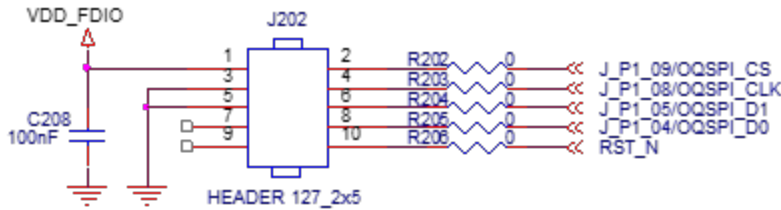

Figure 62. Connector (J202) for direct QSPI Flash programming

5.5 RF Section

To perform conducted RF measurements, do the following hardware modifications:

- Remove C110
- Assemble C132 = 10 pF

To perform OTA measurements, do the following hardware modifications:

- Remove C132
- Assemble C110 = 10 pF

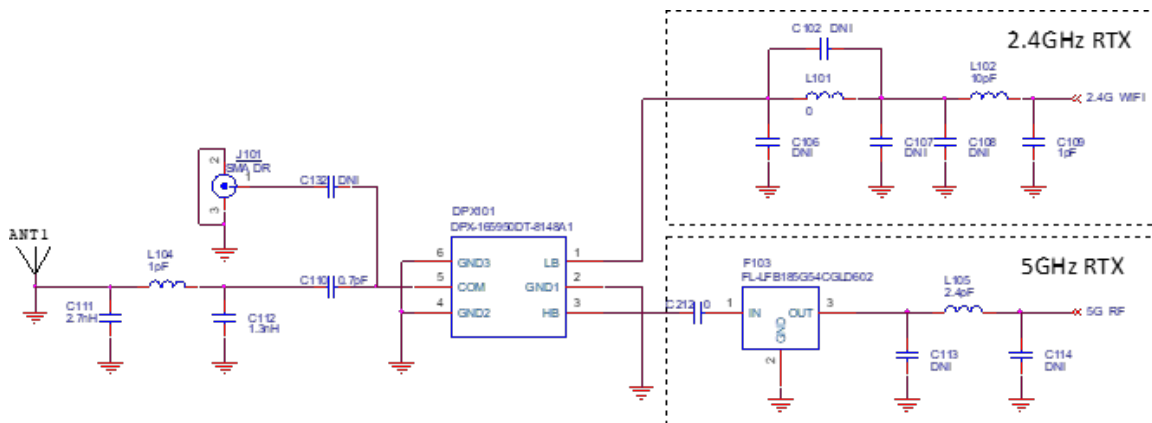

Figure 63. RF section circuitry of RA6W1 daughterboard

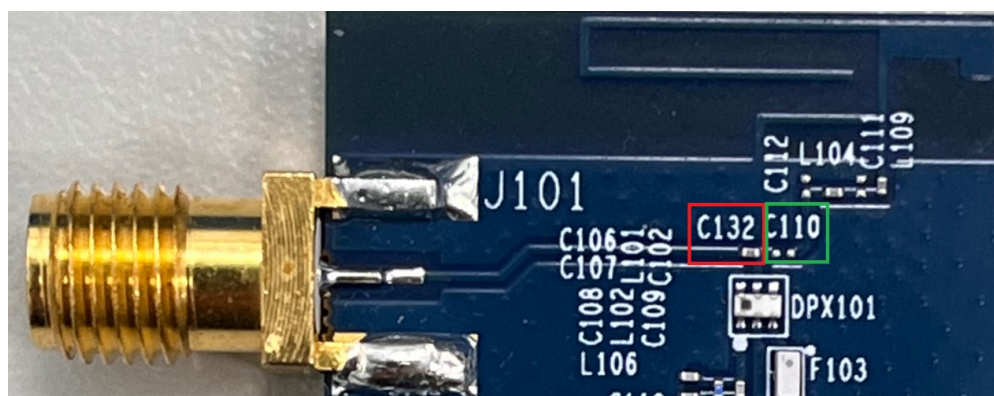

Figure 64. RF section of RA6W1 daughterboard

6. RA6W2 Daughterboard (781-01-x) - RTK7WBA6W2S05000B

RA6W2 MCU (U105): the RA6W2 is a highly integrated ultra-low power Wi-Fi + Bluetooth® Low Energy Combo IC solution. This product includes the Wi-Fi that is a highly integrated ultra-low power Wi-Fi system on a chip (SoC) integrating an Arm® Cortex®-M33 system processor with a dual band 802.11a/b/g/n/ax Wi-Fi subsystem, on-chip memory, flexible peripheral interfaces and power management features.

On RA6W2 daughterboard (board number 781-01-x) all necessary components required for the system setup are applied. Daughterboard, accompanied by the Motherboard, provides the capability for RA6W2 system evaluation and development.

The block diagram and the actual component locations of the RA6W2 daughterboard are shown in [Figure 65](#) and [Figure 66](#).

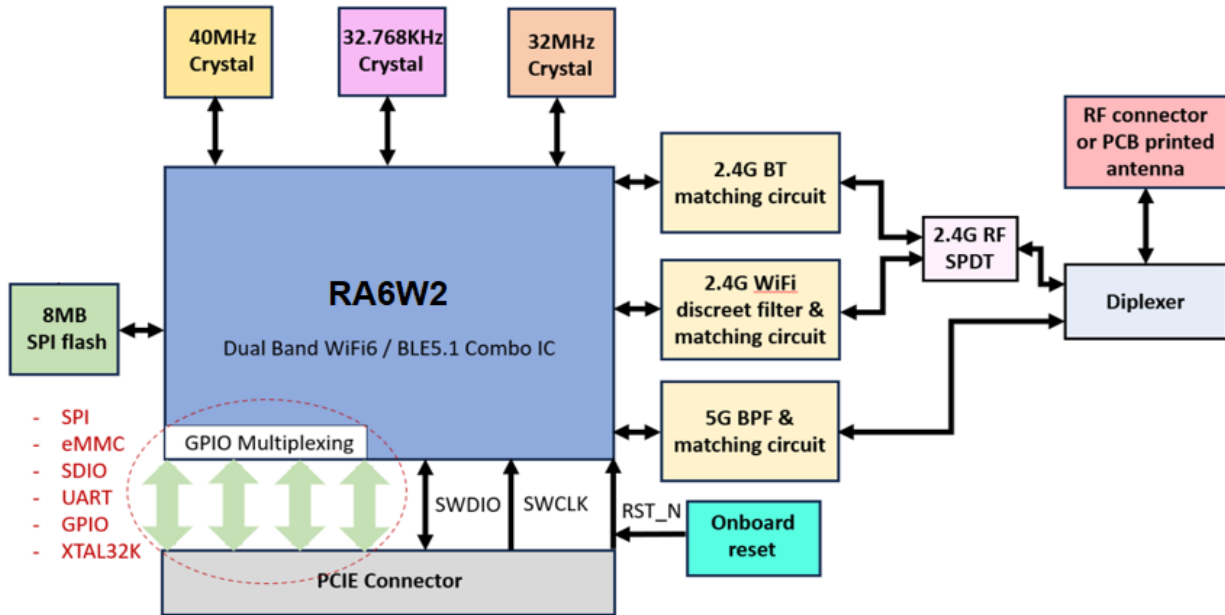

Figure 65. System block diagram of the RA6W2 daughterboard

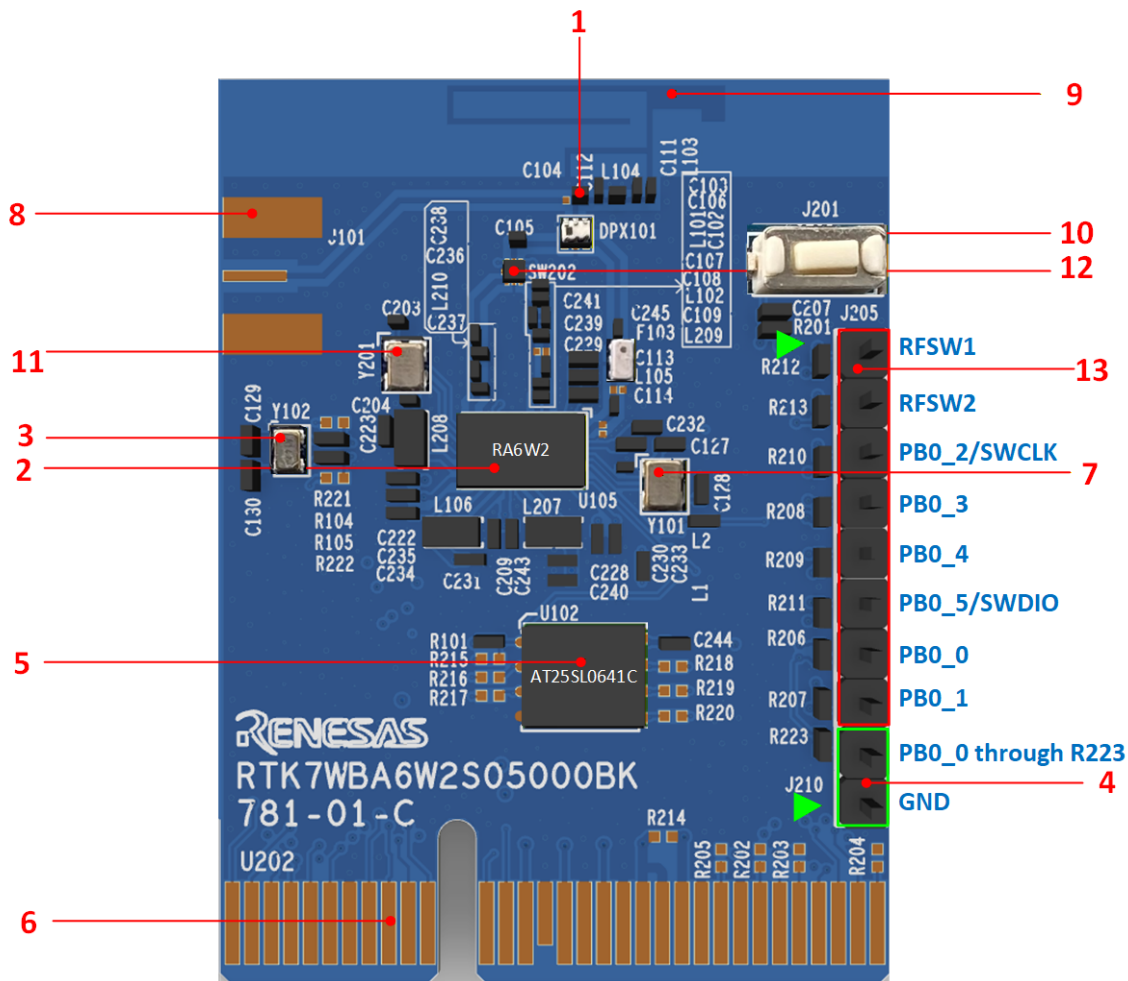

Figure 66. RA6W2 daughterboard component's placement

Table 15. The RA6W2 daughterboard part numbers and description

No	Name	Location
1	Antenna selection network	
2	RA6W2 MCU	U105
3	32.768 kHz XTAL	Y102
4	PB0_0 through resistor R223 and GND pin	J210
5	QSPI NOR Flash	U102
6	PCIE Interface Connector with RA6W1	
7	40 MHz XTAL	Y101
8	SMA Connector	J101
9	PCB Printed Antenna	
10	Onboard reset button for Wi-Fi section	J201
11	32 MHz XTAL	Y201
12	RF SPDT switch	SW202
13	PIN header for RF SPDT switch control pins and Bluetooth LE pins	J205

6.1 RA6W2 GPIOs and Interface to Motherboard

RA6W2 SiP provides 18 GPIOs from Wi-Fi section and 6 GPIOs from Bluetooth LE section. All GPIOs are available on the daughterboard. Daughterboard is connected to Motherboard through a PCIE-64, PCB connector (U202). Only power and Wi-Fi signals are connected to the interface [Figure 67](#) and [Figure 68](#). Bluetooth LE GPIOs are accessible on header J205. The same interface is used for the daughterboards of RA6W1 and RRQ610x1 Modules.

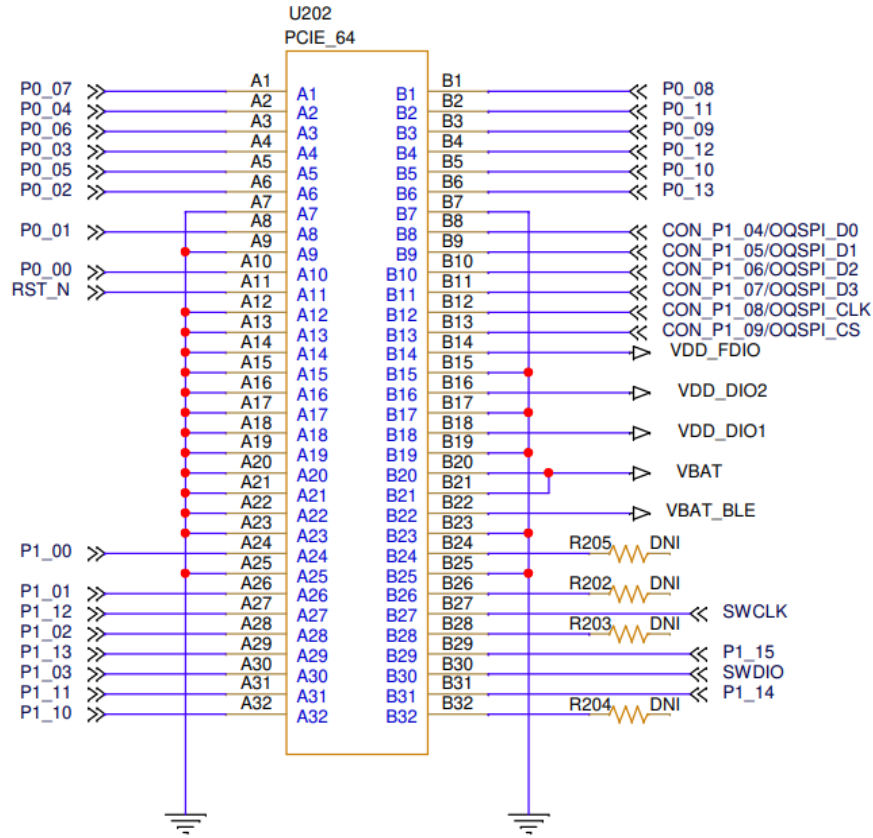

Figure 67. RA6W2 interface to Motherboard, Schematic

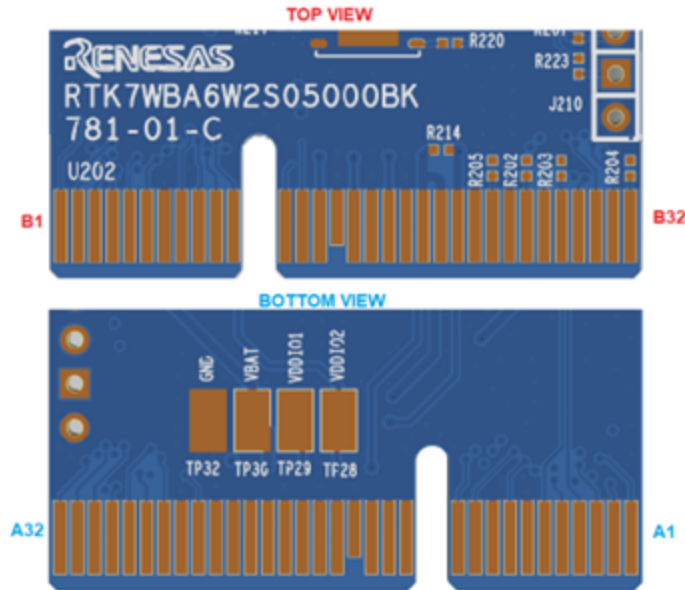

Figure 68. RA6W2 interface to Motherboard PCB

Table 16. Pins assignment for RA6W2 daughterboard

Pins	Section	PWR domain	Access	Connection
PB0_0	Bluetooth LE	VBAT_B	J205, Pin 7	Connected to P1_10
PB0_1	Bluetooth LE	VBAT_B	J205, Pin 8	Connected to P1_11
PB0_2	Bluetooth LE	VBAT_B	J205, Pin 3	Connected to P1_14
PB0_3	Bluetooth LE	VBAT_B	J205, Pin 4	Connected to P1_12
PB0_4	Bluetooth LE	VBAT_B	J205, Pin 5	Connected to P1_13
PB0_5	Bluetooth LE	VBAT_B	J205, Pin 6	Connected to P1_15
RST_N	Wi-Fi	VBAT	U202, Pin A11	
P0_00	Wi-Fi	VBAT	U202, Pin A10	
P0_01	Wi-Fi	VBAT	U202, Pin A8	
P0_02	Wi-Fi	VBAT	U202, Pin A6	32 kHz crystal
P0_03	Wi-Fi	VBAT	U202, Pin A4	32 kHz crystal
P0_04	Wi-Fi	VDDIO_DIO1	U202, Pin A2	
P0_05	Wi-Fi	VDDIO_DIO1	U202, Pin A5	
P0_06	Wi-Fi	VDDIO_DIO1	U202, Pin A3	RFSW1
P0_07	Wi-Fi	VDDIO_DIO1	U202, Pin A1	RFSW2
P0_08	Wi-Fi	VDDIO_DIO1	U202, Pin B1	
P0_09	Wi-Fi	VDDIO_DIO1	U202, Pin B3	
P0_10	Wi-Fi	VDDIO_DIO1	U202, Pin B5	
P0_11	Wi-Fi	VDDIO_DIO1	U202, Pin B2	
P0_12	Wi-Fi	VDDIO_DIO1	U202, Pin B4	
P0_13	Wi-Fi	VDDIO_DIO1	U202, Pin B6	
P1_00	Wi-Fi	VDDIO_FDIO=1.8V	U202, Pin A24	
P1_01	Wi-Fi	VDDIO_FDIO=1.8V	U202, Pin A26	
P1_02	Wi-Fi	VDDIO_FDIO=1.8V	U202, Pin A28	
P1_03	Wi-Fi	VDDIO_FDIO=1.8V	U202, Pin A30	
P1_04	Wi-Fi	VDDIO_FDIO=1.8V	U202, Pin B8	Connected to U202 thru R220 (Not Mounted) – Assigned to OQSPI_D0
P1_05	Wi-Fi	VDDIO_FDIO=1.8V	U202, Pin B9	Connected to U202 thru R216 (Not Mounted) – Assigned to OQSPI_D1
P1_06	Wi-Fi	VDDIO_FDIO=1.8V	U202, Pin B10	Connected to U202 thru R217 (Not Mounted) – Assigned to OQSPI_D2
P1_07	Wi-Fi	VDDIO_FDIO=1.8V	U202, Pin B11	Connected to U202 through R218 (Not Mounted). Assigned to OQSPI_D3

Pins	Section	PWR domain	Access	Connection
P1_08	Wi-Fi	VDDIO_FDIO=1.8 V	U202, Pin B12	Connected to U202 thru R219 (Not Mounted) – Assigned to OQSPI_CLK
P1_09	Wi-Fi	VDDIO_FDIO=1.8 V	U202, Pin B13	Connected to U202 thru R215 (Not Mounted) – Assigned to OQSPI_CS
P1_10	Wi-Fi	VDDIO_DIO2	U202, Pin A32	Connected to P_B0_0
P1_11	Wi-Fi	VDDIO_DIO2	U202, Pin A31	Connected to P_B0_1
P1_12	Wi-Fi	VDDIO_DIO2	U202, Pin A27	Connected to P_B0_3
P1_13	Wi-Fi	VDDIO_DIO2	U202, Pin A29	Connected to P_B0_4
P1_14	Wi-Fi	VDDIO_DIO2	U202, Pin B31	Connected to P_B0_2
P1_15	Wi-Fi	VDDIO_DIO2	U202, Pin B29	Connected to P_B0_5
P1_16	Wi-Fi	VDDIO_DIO2	U202, Pin B27	SWCLK
P1_17	Wi-Fi	VDDIO_DIO2	U202, Pin B30	SWDIO

6.2 Wi-Fi to Bluetooth LE Connectivity and Coexistence

RA6W2 is a System in Package (SiP) that supports Wi-Fi and Bluetooth LE technology. Wi-Fi and Bluetooth LE sections of RA6W2 are standalone and independent to each other. On Daughterboard the two sections are connected to each other through resistors, R206 to R211.

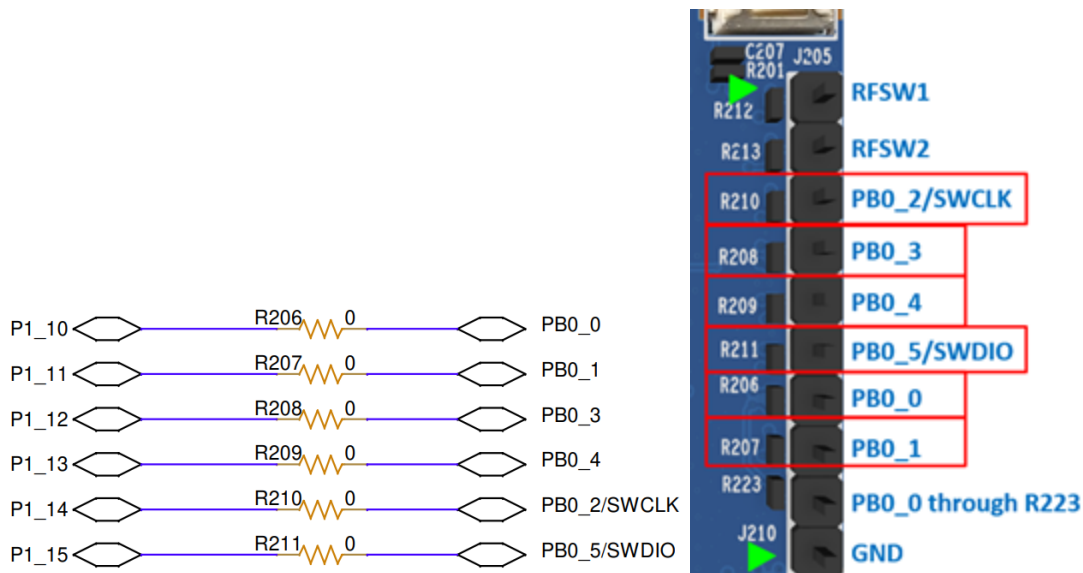

Figure 69. Wi-Fi and Bluetooth LE sections connections on RA6W2 Daughterboard

The connections implement a full-UART interface and the coexistence between the two sections. Pin assignment and functions are shown in [Table 17](#).

Table 17. Connectivity Wi-Fi and Bluetooth LE section of RA6W2

Bluetooth LE pins		Connected through Resistor	Wi-Fi Pins	
Bluetooth LE Pins	Function	Function	Wi-Fi pins	
PB0_0	UTX (Bluetooth LE)	R206	URX (Wi-Fi)	P1_10
PB0_1	URX (Bluetooth LE)	R207	UTX (Wi-Fi)	P1_11
PB0_2	BLE_RST / SWCLK	R210	BLE_RST	P1_14
PB0_3	URTS (Bluetooth LE)	R208	UCTS (Wi-Fi)	P1_12
PB0_4	UCTS (Bluetooth LE)	R209	URTS (Wi-Fi)	P1_13
PB0_5	iBtAct / SWDIO	R211	Coex	P1_15

NOTE

Wi-Fi pins are supplied from VDD_DIO2 whereas Bluetooth LE pins are supplied from VBAT_BLE. Both voltage rails must have the same voltage level or leakages may occur.

6.3 Reset

Push-button J201 is used for resetting Wi-Fi section of RA6W2. Reset can be enabled also from button J607 on Motherboard, see [Section 1.8 Push-buttons](#).

RESET

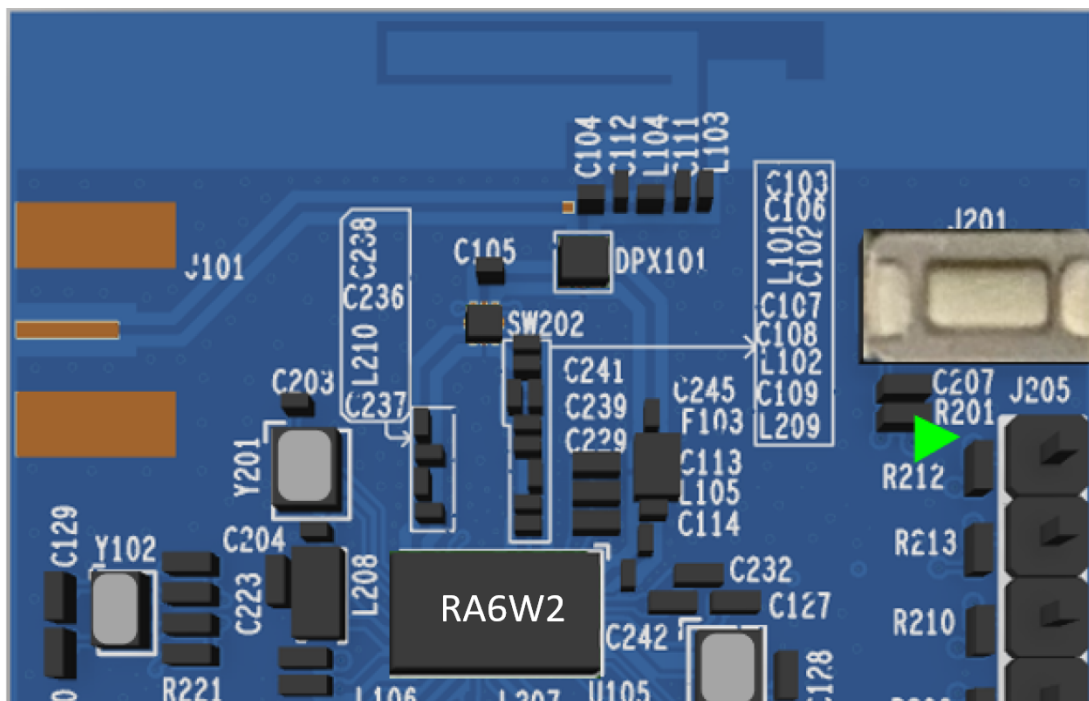
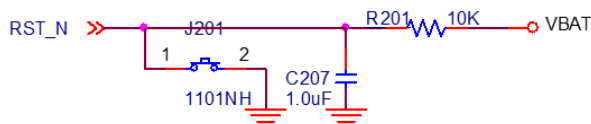

Figure 70. Reset push-button. J201

6.4 Clocks

- 40 MHz XTAL (Y101):** the main clock of the Wi-Fi system is generated from a 40 MHz XTAL which is connected to the internal clock oscillator. The selected crystal for RA6W1 is the CX2016DB40000D0FLJCC of [KYOCERA AVX](#).
- 32.768 kHz XTAL (Y102):** the RTC can be clocked with a 32.768 kHz crystal or from a calibrated internal 32 kHz RC oscillator. For applications with more demanding accuracy/drift characteristics, such as timekeeping, using an external 32.768 kHz crystal is a suitable solution and the selected crystal is the FC-12M 32.7680KA-A5 of EPSON timing. By default, the external 32.768 kHz crystal is assembled on RA6W2. 32.768 kHz is connected to RA6W2 (Wi-Fi section) through P0_02 and P0_03.
- 32 MHz XTAL (Y201):** the main clock of the BT system is generated from a 32 MHz XTAL which is connected to the internal clock oscillator. The selected crystal for RA6W2 is the CX2016DB32000D0FLJCC of [KYOCERA AVX](#).

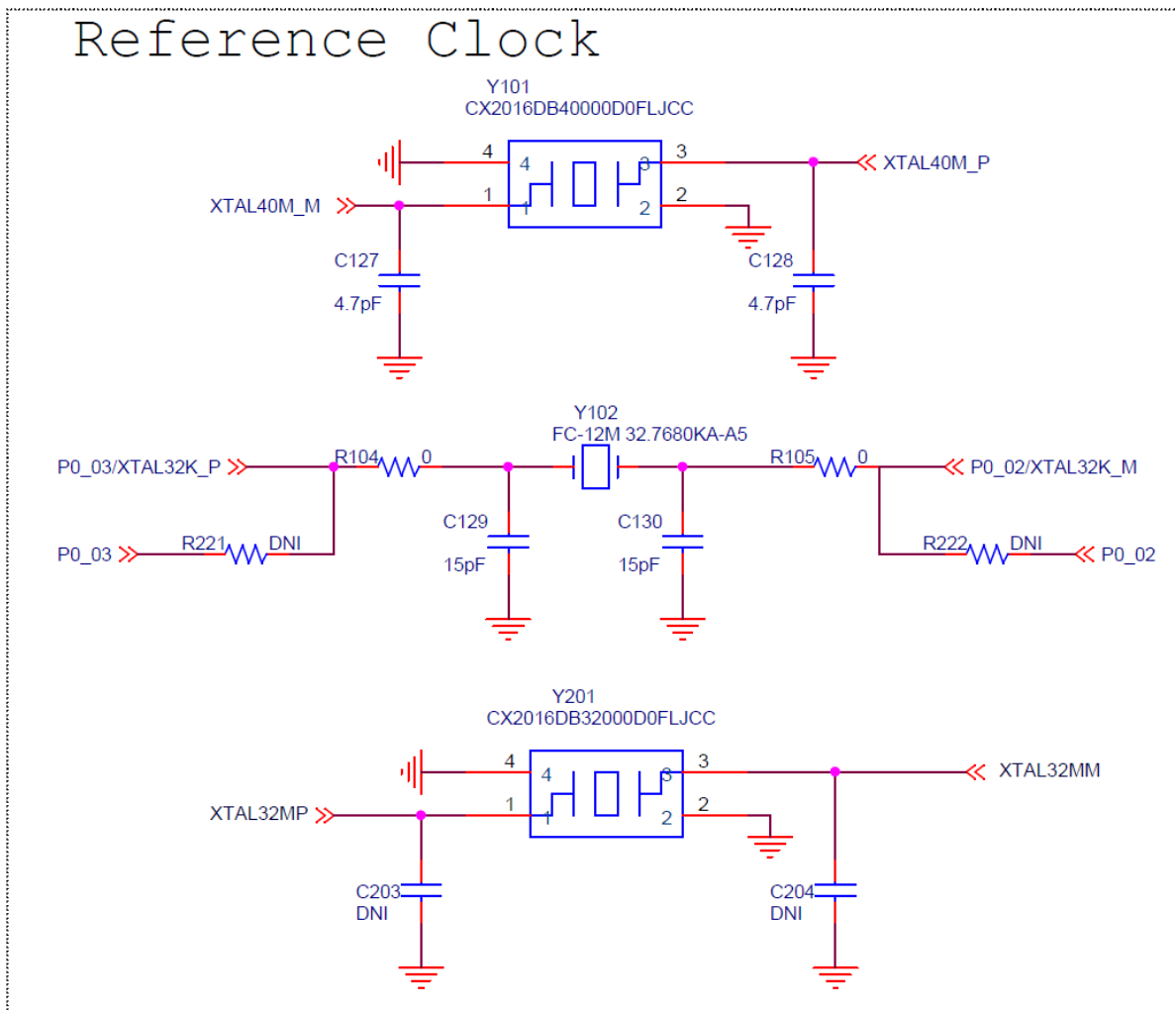

Figure 71. XTALs of RA6W2 daughterboard

6.5 QSPI NOR Flash

The used component is the Renesas AT25SL641-MHE-T or AT25SL641C-MHE-T for RA6W2. By default, the SPI Flash (U102) is mounted on this daughterboard. QSPI NOR Flash is connected to the QSPI bus of Wi-Fi of the SiP and operates as an eXecution in Place (XiP) memory.

QSPI bus is connected to the PCI bus through Not Mounted resistors R215 to R220. Consequently, by default, QSPI bus is not available to the Motherboard.

QSPI NOR Flash is supplied from VDD_FDIO = 1.8 V, generated from the RA6W2. Operating frequency is equal to 80 MHz.

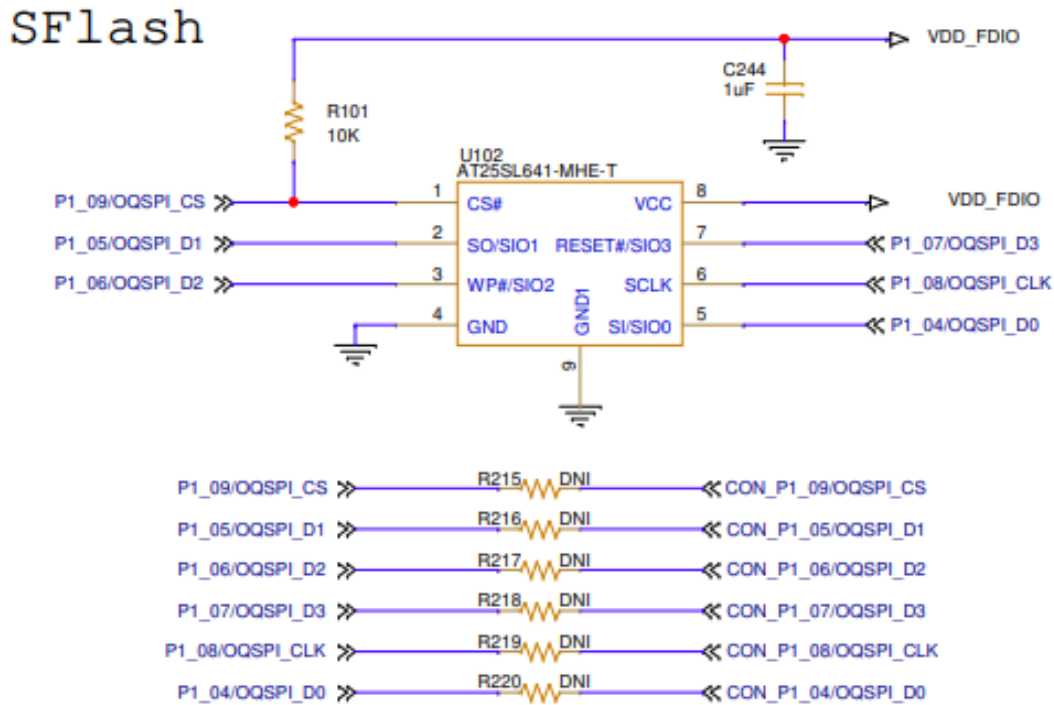

Figure 72. SPI-Flash circuitry on RA6W2 daughterboard

Control signals, RFSW1 and RFSW2 are connected to P0_06 and P0_07 respectively of Wi-Fi. Connection is done through R212 and R213. RFSW1 and RFSW2 are available for monitoring on header J209, see [Table 18](#).

Table 18. SKY13351 RF SPDT truth table

RF SPDT switch – Control logic			
	J209	Wi-Fi operation	Bluetooth LE operation
P0_06	RFSW1	LOW	HIGH
P0_07	RFSW2	HIGH	LOW

7. RRQ610x1 Module Daughterboard (565-16-x) - RTK7WBRQ61S0x000BK

RRQ610x1-00x Module presents four variants. The variants are shown in [Table 19](#).

Table 19. RRQ610x1-00x variants

Part number	Board number	Description
RRQ61001-008	565-20-C	Wi-Fi 6 Dual Band 2.4/5 GHz, 802.11 a/b/g/n/ax, 8 MB Flash, PCB Trace antenna
RRQ61001-009	565-21-C	Wi-Fi 6 Dual Band 2.4/5 GHz, 802.11 a/b/g/n/ax, 8 MB Flash, External antenna connector, uFL
RRQ61051-008	565-20-C	Wi-Fi/Bluetooth LE combo module, Wi-Fi 6 Dual Band 2.4/5 GHz, 802.11 a/b/g/n/ax, 8 MB Flash, PCB Trace antenna
RRQ61051-009	565-21-C	Wi-Fi/Bluetooth LE combo module, Wi-Fi 6 Dual Band 2.4/5 GHz, 802.11 a/b/g/n/ax, 8 MB Flash, External antenna connector, uFL

The two RRQ61001-00x module variants (-008 for printed antenna and -009 for uFL), offer highly integrated wireless communication solutions, based on Wi-Fi. They include the RA6W1 system on chip (SoC) that has an 802.11 a/b/g/n/ac/ax radio (PHY), a baseband processor, a media access controller (MAC), on-chip memory, and an Arm[®] Cortex[®]-M33 core processor running at 160 MHz.

The two Renesas RRQ61051-00x module variants (-008 for antenna and -009 for uFL), offer highly integrated Combo Wi-Fi + Bluetooth[®] Low Energy (LE). These modules include the RA6W1 MCU and a DA14531 SoC. DA14531 has a 2.4 GHz transceiver and an Arm[®] Cortex[®]-M0+ microcontroller with a RAM of 48 kB and a One-Time Programmable (OTP) memory of 32 kB. The radio transceiver, the baseband processor, and the qualified Bluetooth LE stack is fully compliant with the Bluetooth LE 5.1 standard.

All variants of the module use an 8 MB Flash.



Figure 76. RRQ610x1-009 uFL (left) and RRQ610x1-008 printed antenna (right)

The RRQ610x1 daughterboard (565-16-x) carries all four variants of RRQ610x1 Modules. When combined with the Motherboard (565-11-x), it provides the capability to test, evaluate, and develop applications.

The block diagram and the actual component locations of the RRQ610x1 daughterboard are shown in [Figure 77](#) and [Figure 78](#).

Table 20. Part numbers of the Evaluation Daughterboard for RRQ610x1-00x Module

Part number	Name	Board number
RTK7WBRQ61S01000BK	Evaluation Daughterboard for RRQ61001-008	565-16-x
RTK7WBRQ61S02000BK	Evaluation Daughterboard for RRQ61001-009	565-16-x
RTK7WBRQ61S03000BK	Evaluation Daughterboard for RRQ61051-008	565-16-x
RTK7WBRQ61S04000BK	Evaluation Daughterboard for RRQ61051-009	565-16-x

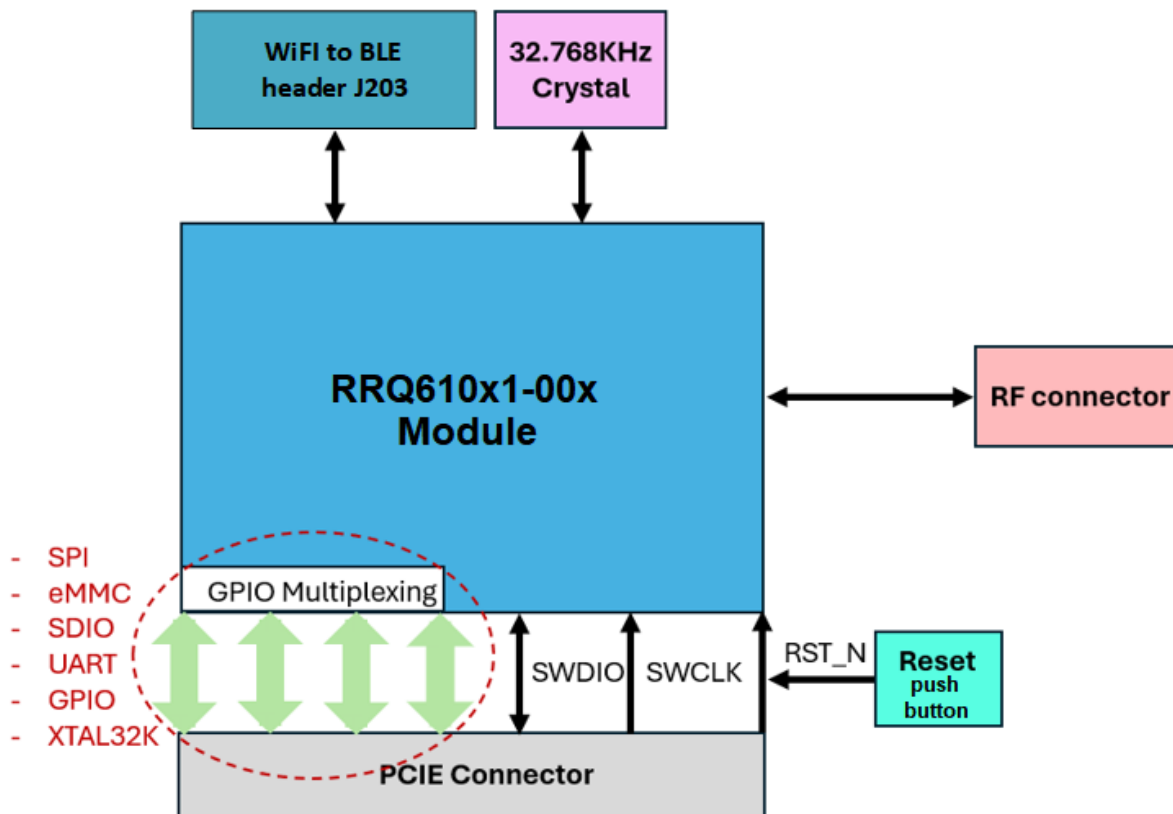

Figure 77. System block diagram of RRQ61051 module

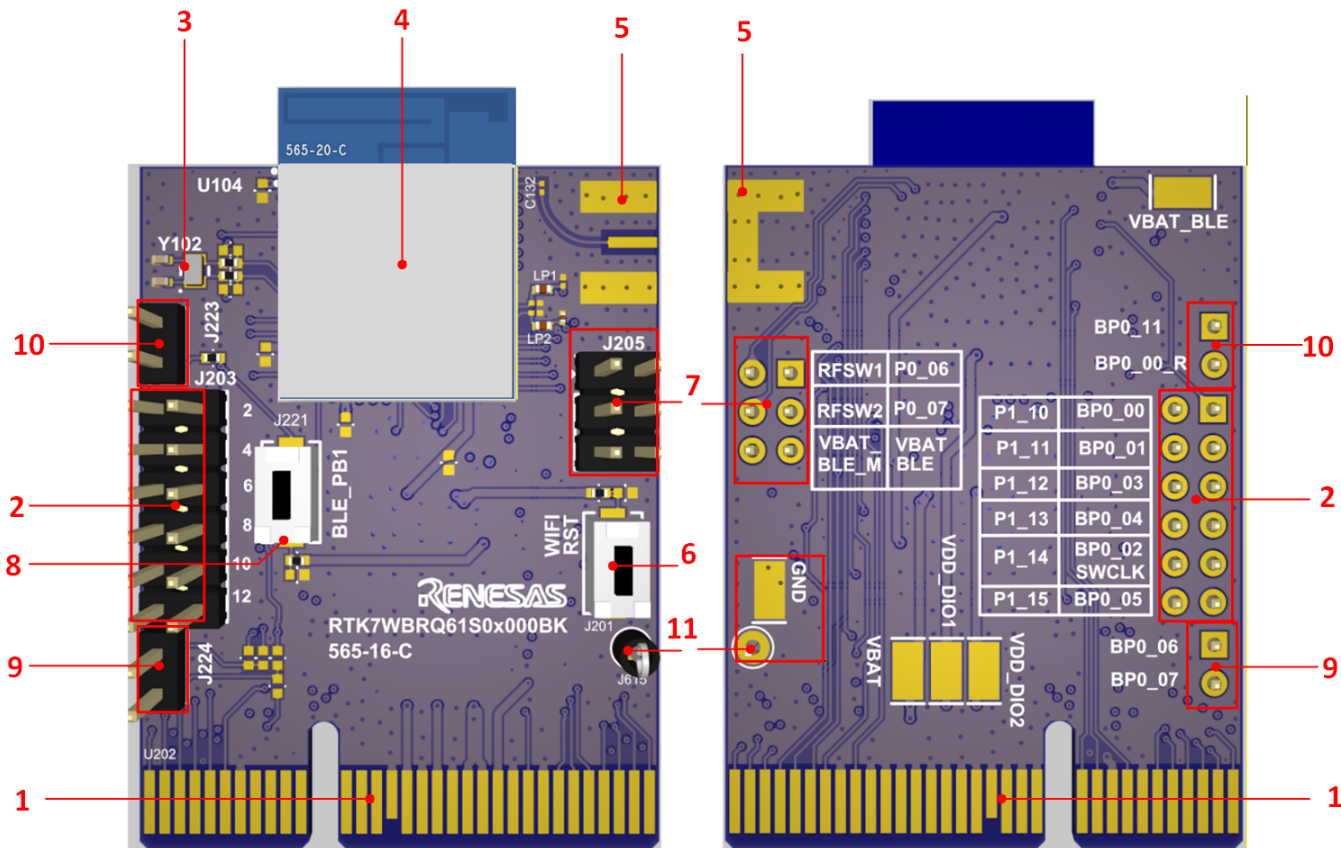

Figure 78. RRQ610x1 Daughterboard Component's placement (top left, bottom right)

Table 21. RRQ610x1-00x Daughterboard main components

No	Name	Location
1	PCIE PCB Connector. Interface to Motherboard (565-11-x) of EVK	U202
2	Pin header for Wi-Fi and Bluetooth LE sections of RRQ610x1 Modules. For the RRQ61051 Module, the header is used for connecting signals of Wi-Fi and Bluetooth LE for communication and coexistence.	J203
3	32.768KHz XTAL	Y102
4	RRQ610x1 module. Four variants of Module are mounted on Daughterboard	U104
5	SMA Connector – Not in use	U101
6	Reset push-button	J201
7	PIN header for RF switch and Bluetooth LE power supply. Jumpers must be applied to enable the connections.	J205
8	Push-button connecting B_P0_00 of Bluetooth LE to VBAT_BLE	J221
9	Monitoring header for B_P0_06 and B_P0_07	J224
10	Monitoring header for B_P0_11 and B_P0_00 through resistor R233	J223
11	GND	J615, TP32

7.1 RRQ610x1-00x Module GPIOs and Interface to Motherboard

RRQ61001 Modules provide 26 GPIOs whereas RRQ61051 Modules provide 38 GPIOs, 26 GPIOs from Wi-Fi, and 12 GPIOs from Bluetooth LE. All GPIOs are available to be accessed on Daughterboard or Motherboard through a PCIe-64, PCB connector (U202), see Figure 79.

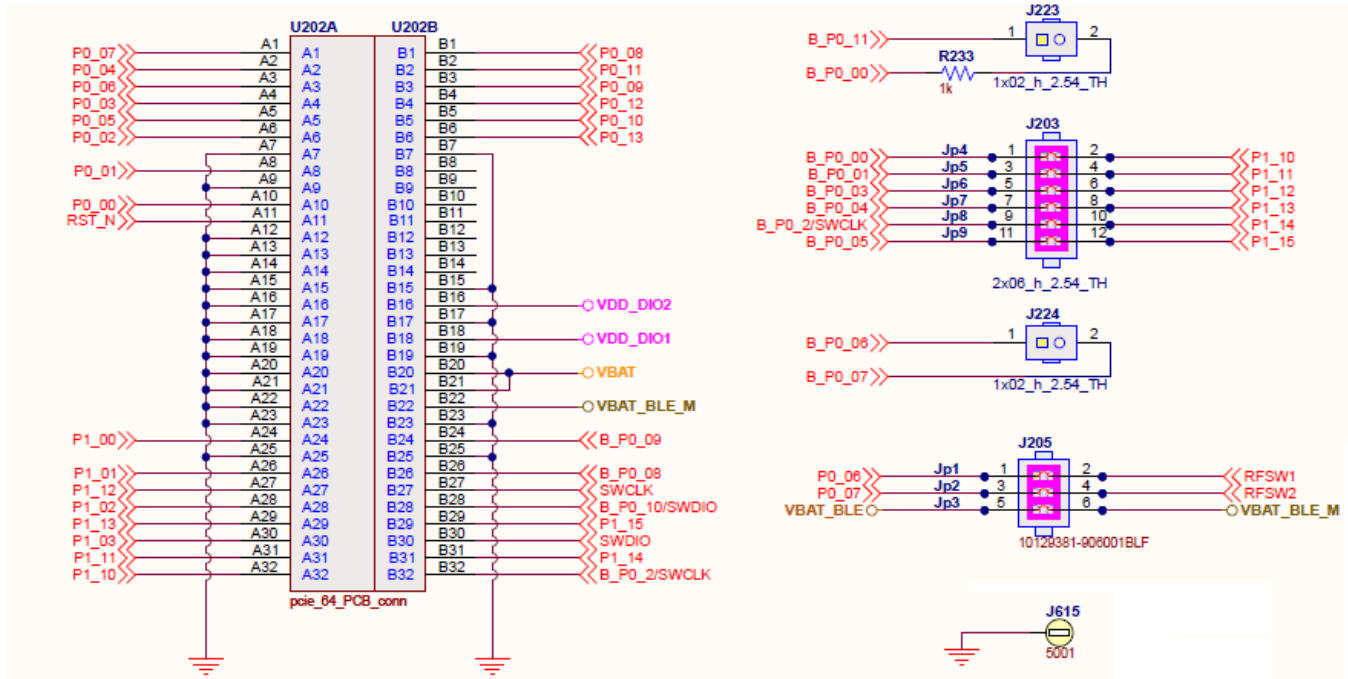

Figure 79. RRQ610x1 Daughterboard Interface to Motherboard (left) and headers (right)

As daughterboard is used for all variants of the Module, the Bluetooth LE signals are not available when the RRQ61001 are mounted. Table 22 and Table 23 show which GPIOs are available, their connectivity and their function.

Table 22. Daughterboard pins assignment for RRQ61001 Modules

Pins	Section	PWR domain	Access	Connection
P_B0_0				Not Available
P_B0_1				Not Available
P_B0_2				Not Available
P_B0_3				Not Available
P_B0_4				Not Available
P_B0_5				Not Available
P_B0_6				Not Available
P_B0_7				Not Available
P_B0_8				Not Available
P_B0_9				Not Available
P_B0_10				Not Available
P_B0_11				Not Available
RST_N	Wi-Fi	VBAT	U202, Pin A11	
P0_00	Wi-Fi	VBAT	U202, Pin A10	
P0_01	Wi-Fi	VBAT	U202, Pin A8	
P0_02	Wi-Fi	VBAT	U202, Pin A6	32 kHz crystal
P0_03	Wi-Fi	VBAT	U202, Pin A4	32 kHz crystal
P0_04	Wi-Fi	VDDIO_DIO1	U202, Pin A2	
P0_05	Wi-Fi	VDDIO_DIO1	U202, Pin A5	
P0_06	Wi-Fi	VDDIO_DIO1	U202, Pin A3	
P0_07	Wi-Fi	VDDIO_DIO1	U202, Pin A1	
P0_08	Wi-Fi	VDDIO_DIO1	U202, Pin B1	
P0_09	Wi-Fi	VDDIO_DIO1	U202, Pin B3	
P0_10	Wi-Fi	VDDIO_DIO1	U202, Pin B5	
P0_11	Wi-Fi	VDDIO_DIO1	U202, Pin B2	
P0_12	Wi-Fi	VDDIO_DIO1	U202, Pin B4	
P0_13	Wi-Fi	VDDIO_DIO1	U202, Pin B6	
P1_00	Wi-Fi	VDDIO_FDIO=1.8 V	U202, Pin A24	
P1_01	Wi-Fi	VDDIO_FDIO=1.8 V	U202, Pin A26	
P1_02	Wi-Fi	VDDIO_FDIO=1.8 V	U202, Pin A28	
P1_03	Wi-Fi	VDDIO_FDIO=1.8 V	U202, Pin A30	
P1_10	Wi-Fi	VDDIO_DIO2	U202, Pin A32	
P1_11	Wi-Fi	VDDIO_DIO2	U202, Pin A31	
P1_12	Wi-Fi	VDDIO_DIO2	U202, Pin A27	
P1_13	Wi-Fi	VDDIO_DIO2	U202, Pin A29	
P1_14	Wi-Fi	VDDIO_DIO2	U202, Pin B31	
P1_15	Wi-Fi	VDDIO_DIO2	U202, Pin B29	
P1_16	Wi-Fi	VDDIO_DIO2	U202, Pin B27	SWCLK
P1_17	Wi-Fi	VDDIO_DIO2	U202, Pin B30	SWDIO

Table 23. Daughterboard pins assignment for RRQ61051 Modules

Pins	Section	PWR domain	Access	Connection
P_B0_0	Bluetooth LE	VBAT_B	J203. Pin 1	Connected to P1_10
P_B0_1	Bluetooth LE	VBAT_B	J203. Pin 3	Connected to P1_11
P_B0_2	Bluetooth LE	VBAT_B	J203. Pin 9, U202. Pin B32	Connected to P1_14
P_B0_3	Bluetooth LE	VBAT_B	J203. Pin 5	Connected to P1_12
P_B0_4	Bluetooth LE	VBAT_B	J203. Pin 7	Connected to P1_13
P_B0_5	Bluetooth LE	VBAT_B	J203. Pin 11	Connected to P1_15
P_B0_6	Bluetooth LE	VBAT_B	J224, Pin 1	
P_B0_7	Bluetooth LE	VBAT_B	J224, Pin 2	
P_B0_8	Bluetooth LE	VBAT_B	U202, Pin B26	
P_B0_9	Bluetooth LE	VBAT_B	U202, Pin B24	
P_B0_10	Bluetooth LE	VBAT_B	U202, Pin B28	
P_B0_11	Bluetooth LE	VBAT_B	J223, pin 1	
RST_N	Wi-Fi	VBAT	U202, Pin A11	
P0_00	Wi-Fi	VBAT	U202, Pin A10	
P0_01	Wi-Fi	VBAT	U202, Pin A8	
P0_02	Wi-Fi	VBAT	U202, Pin A6	32 kHz crystal. Not available on U202
P0_03	Wi-Fi	VBAT	U202, Pin A4	32 kHz crystal. Not available on U202
P0_04	Wi-Fi	VDDIO_DIO1	U202, Pin A2	
P0_05	Wi-Fi	VDDIO_DIO1	U202, Pin A5	
P0_06	Wi-Fi	VDDIO_DIO1	U202, Pin A3	RFSW1
P0_07	Wi-Fi	VDDIO_DIO1	U202, Pin A1	RFSW2
P0_08	Wi-Fi	VDDIO_DIO1	U202, Pin B1	
P0_09	Wi-Fi	VDDIO_DIO1	U202, Pin B3	
P0_10	Wi-Fi	VDDIO_DIO1	U202, Pin B5	
P0_11	Wi-Fi	VDDIO_DIO1	U202, Pin B2	
P0_12	Wi-Fi	VDDIO_DIO1	U202, Pin B4	
P0_13	Wi-Fi	VDDIO_DIO1	U202, Pin B6	
P1_00	Wi-Fi	VDDIO_FDIO=1.8 V	U202, Pin A24	
P1_01	Wi-Fi	VDDIO_FDIO=1.8 V	U202, Pin A26	
P1_02	Wi-Fi	VDDIO_FDIO=1.8 V	U202, Pin A28	
P1_03	Wi-Fi	VDDIO_FDIO=1.8 V	U202, Pin A30	
P1_10	Wi-Fi	VDDIO_DIO2	U202, Pin A32	Connected to P_B0_0
P1_11	Wi-Fi	VDDIO_DIO2	U202, Pin A31	Connected to P_B0_1
P1_12	Wi-Fi	VDDIO_DIO2	U202, Pin A27	Connected to P_B0_3
P1_13	Wi-Fi	VDDIO_DIO2	U202, Pin A29	Connected to P_B0_4
P1_14	Wi-Fi	VDDIO_DIO2	U202, Pin B31	Connected to P_B0_2
P1_15	Wi-Fi	VDDIO_DIO2	U202, Pin B29	Connected to P_B0_5
P1_16	Wi-Fi	VDDIO_DIO2	U202, Pin B27	SWCLK
P1_17	Wi-Fi	VDDIO_DIO2	U202, Pin B30	SWDIO

7.2 Wi-Fi to Bluetooth LE Connectivity and Coexistence for RRQ61051

RRQ61051 Modules support Wi-Fi and Bluetooth LE technology. Wi-Fi and Bluetooth LE sections are two stand-alone systems which combine on RF side (an RF switch is located internally to the Module, but control signals are external) and connected on digital interface to each other for establishing communication and coexistence. The connections on digital interface are external to Module, and they are implemented through headers J203 and J205.

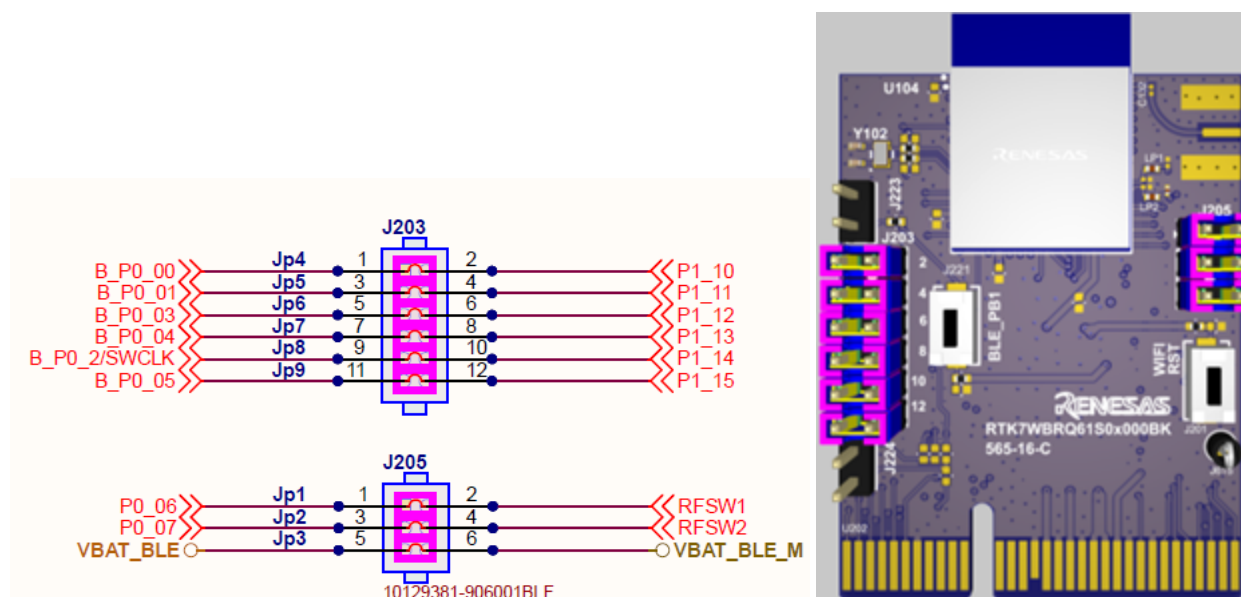

Figure 80. Wi-Fi and Bluetooth LE sections connections on Daughterboard for RRQ61051 Modules

The connections implement a full-UART interface and the coexistence between the two sections. Pin assignment and functions are shown in Table 24.

Table 24. Connectivity Wi-Fi and Bluetooth LE section of RRQ61051 Modules

Bluetooth LE pins		Apply jumper	Wi-Fi Pins	
Bluetooth LE Pins	Function	Function	Wi-Fi pins	
P_BO_0	UTX (Bluetooth LE)	J203. 1-2	URX (Wi-Fi)	P1_10
P_BO_1	URX (Bluetooth LE)	J203. 3-4	UTX (Wi-Fi)	P1_11
P_BO_2	BLE_RST/SWCLK	J203. 9-10	BLE_RST	P1_14
P_BO_3	URTS (Bluetooth LE)	J203. 5-6	UCTS (Wi-Fi)	P1_12
P_BO_4	UCTS (Bluetooth LE)	J203. 7-8	URTS (Wi-Fi)	P1_13
P_BO_5	iBtAct /SWDIO	J203. 11-12	Coex	P1_15

NOTE

Wi-Fi pins are supplied from VDD_DIO2 whereas Bluetooth LE pins are supplied from VBAT_BLE. Both voltage rails must have the same voltage level or leakages may occur.

Table 25. RF switch control

Pins	Apply jumper	Pins	Function
P0_06	J205. 1-2	RFSW1	Enable Bluetooth LE when RFSW1=High and RFSW2 = Low Enable Wi-Fi when RFSW1=Low and RFSW2 = High
P0_07	J205. 3-4	RFSW2	
VBAT_BLE_M	J205. 5-6	VBAT_BLE	Power Bluetooth LE Section

7.3 Jumper Settings for RRQ61001 Modules

As there is Bluetooth LE on RRQ61001 Modules, no jumpers required on daughterboards with RRQ61001.

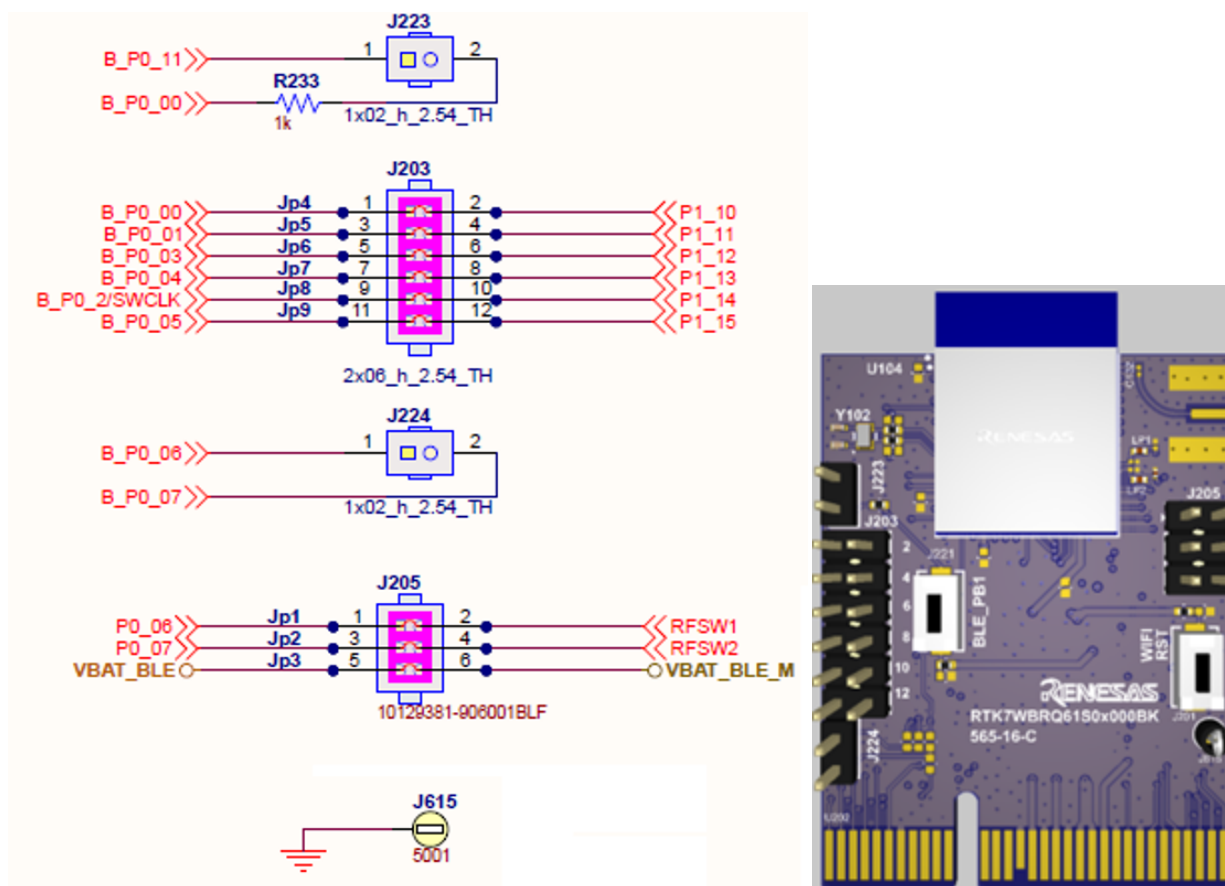

Figure 81. Jumper settings for RRQ61001 daughterboard

7.4 Reset and Push-buttons

Push-button **J201**, is used for resetting Wi-Fi section of RRQ610x1 Modules. Reset can be enabled also from button J607 on Motherboard, see [Section 1.8. Push-buttons](#).

Push-button **J202** connects B_P0_00 of Bluetooth LE with a strong pull-up to VBAT_BLE. Note that during Bluetooth LE booting, B_P0_00 is configured as Reset (Active High). Push-button J202 is enabled only with RRQ61051 modules.

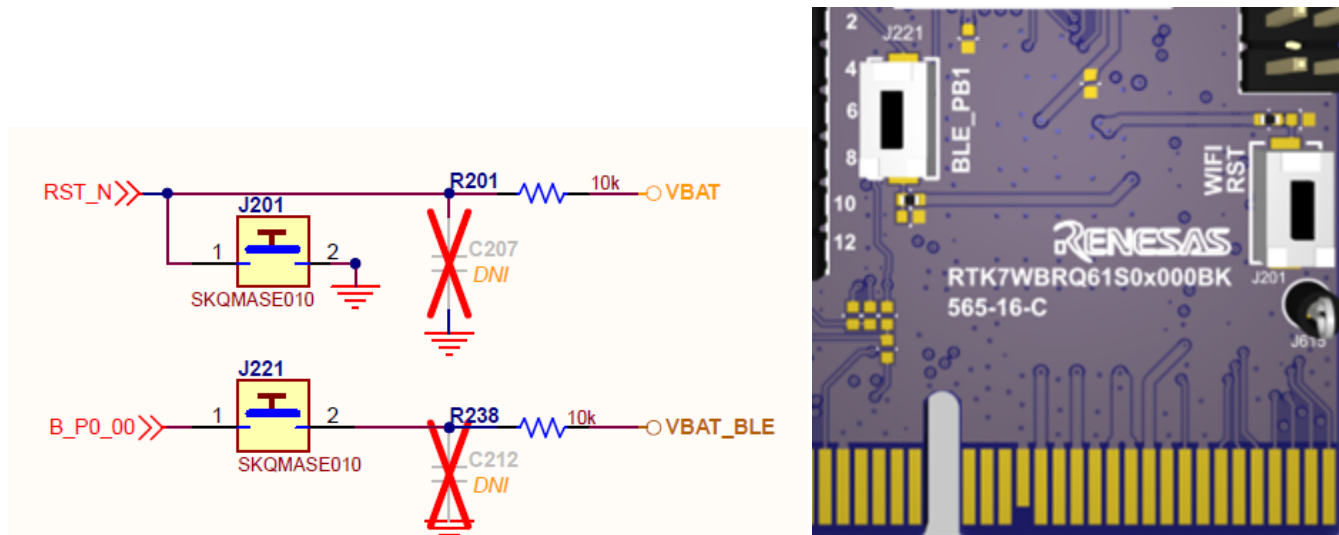

Figure 82. Push-buttons of RRQ610x1 daughterboard

7.5 The Crystal 32.768 kHz

32.768 kHz XTAL (Y102): is used for applications with demanding accuracy/drift characteristics, such as timekeeping. The selected crystal is the FC-12M 32.7680KA-A5 of EPSON timing. By default, the external 32.768 kHz crystal is assembled on RRQ610x1 Daughterboard. GPIOs P0_2 and P0_03 are not available either to U202, nor Motherboard.

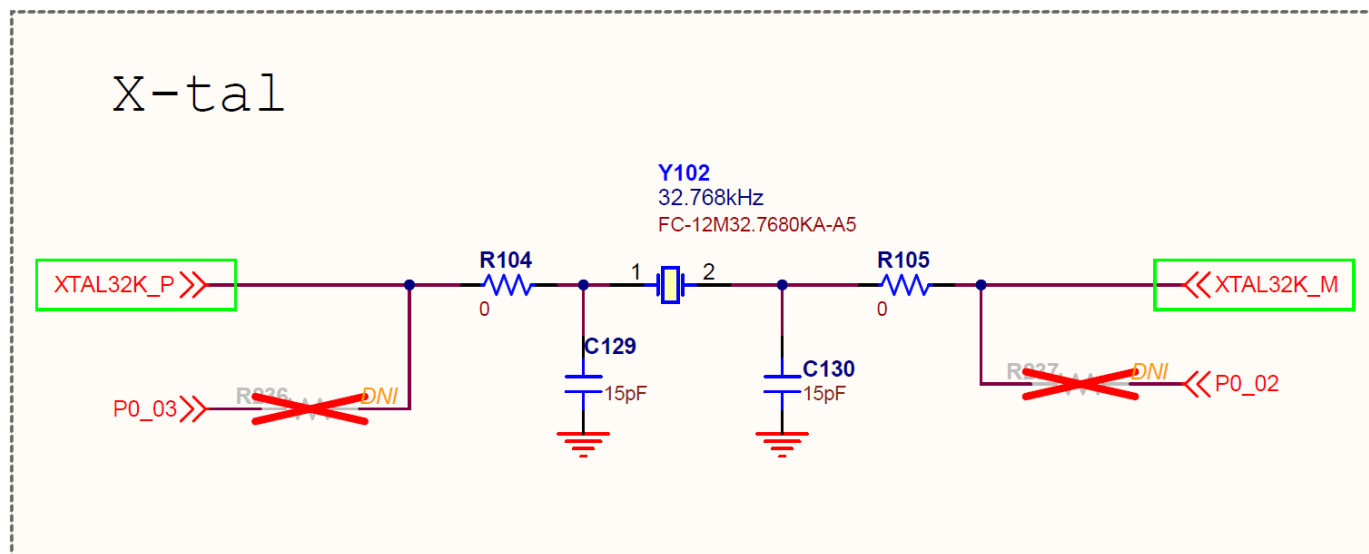

Figure 83. 32.768 kHz crystal

7.6 RF Section

- On RRQ610x1 Daughterboard, there is a place holder for SMA RF connector (J101). This connector is used only for RRQ610x1-010 models.
- For performing RF-conducted measurements with RTK7WBRQ61S04000BK (RRQ61051-009 Module), add an AC coupling capacitor on the RF output of the host PCB. This is not necessary for RRQ61001-009 Module.
- For performing conducted measurements with RTK7WBRQ61S04000BK (RRQ61051-009), using an external attenuator, ensure that a DC block is applied between the module and the attenuator. This is not necessary for RRQ61001-009 Module.

Appendix B Regulatory Information

B.1 RA6W1 Evaluation Kit

Renesas RA6W1 Evaluation Kit conforms to laws and regulations that are described in the following subsections.

B.1.1 FCC Notice (Applicable to Evaluation Kits not FCC-Approved)

This kit is designed to allow product developers to evaluate electronic components, circuitry, or software associated with the kit to determine whether to incorporate such items in a finished product and software developers to write software applications for use with the [end product](#). This kit is not a finished product and when assembled may not be resold or otherwise marketed unless all required FCC equipment authorizations are first obtained. [Operation](#) is subject to the condition that this product not cause [harmful interference](#) to licensed [radiostations](#) and that this product accept [harmful interference](#). Unless the assembled kit is designed to operate under part 15, part 18 or part 95 of this chapter, the operator of the kit must operate under the authority of an FCC license holder or must secure an experimental authorization under part 5 of this chapter.

B.1.2 CE (Radio Equipment Directive 2014/53/EU (RED)) – (Europe)

The RA6W1 Main Board (RTK7WBA6W1S01000BK) has been tested and found to comply with **EMC Directive (2014/30/EU)** for electromagnetic compatibility. Applicable standards are the following:

- **EN 55032:2015+A1 2020 Class B & EN 55035:2017+A11 2020.**

The RA6W1 QFN66 Daughterboard (RTK7WBA6W1S02000BK) has been tested and found to comply with RED 2014/53/EU Essential Requirements for Health, Safety, and Radio. The applicable standards are:

- **Radio:** EN 300 328 V2.2.2 (2019-07), EN 301 893 V2.1.1 (2017-05), EN 300 440 V2.2.1 (2018-07)
- **Health:** EN IEC 62311:2020, EN 50665:2017, EN 50385:2017
- **Safety:** IEC 62368-1:2014, EN 62368-1:2014+A11:2017, BS EN 62368-1:2014+A11:2017
- **EMC:** EN 301 489-1 V2.2.3 (2019-11) Class B, EN 301 489-17 V3.3.1 (2024-09), EN 55032:2015+A1:2020 Class B, EN 55035:2017+A11:2020.

Simplified Declaration of Conformity

Hereby, Renesas Design Inc. declares that radio type equipment RA6W1 QFN66 Daughterboard with product number **RTK7WBA6W1S02000BK** is in compliance with Directive 2014/53/EU. RA6W1 Main Board with part number **RTK7WBA6W1S01000BK** is in compliance with **EMC Directive (2014/30/EU)**. Therefore, RA6W1 Evaluation Kit with part number **RTK7WBA6W1S04000BK**, consisting of the two above-mentioned boards is compliant with applicable EU Directives. The evaluation kit, when considered as an assembly, meets the applicable requirements of the EMC Directive and RED through its constituent boards. The full texts of the EU declaration of conformity are available at the following internet address:
www.renesas.com

This equipment complies with EU radiation exposure limits set forth for an uncontrolled environment. This equipment should be installed and operated at a minimum distance of 20 cm between the radiator and your body.

- 2412-2472MHz: 20 dBm
- 5180-5240MHz: 23 dBm
- 5260-5320MHz: 23 dBm
- 5500-5700: 23 dBm
- 5745-5825MHz: 13.98 dBm

The device is restricted to indoor use only when operating in the 5150 to 5350 MHz frequency range.

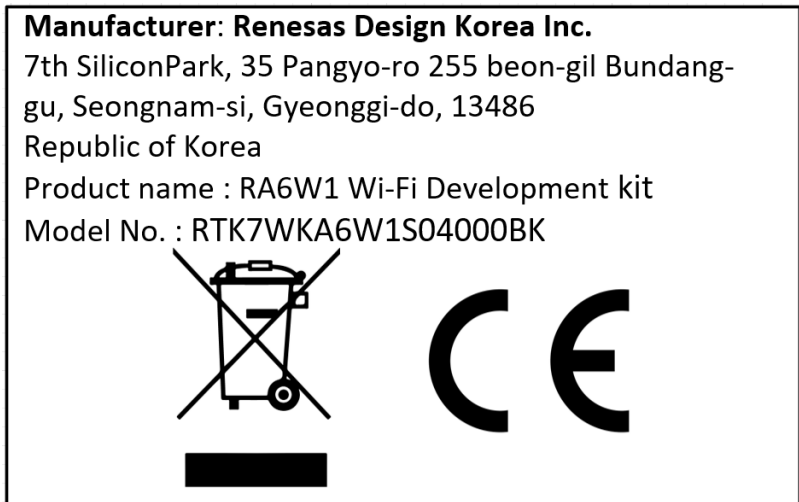

Figure 85. EU directive labels

B.1.3 UKCA (UK)

The RA6W1 Main Board (RTK7WBA6W1S01000BK) has been tested and found to comply with **EMC Directive (2014/30/EU)** for electromagnetic compatibility. Applicable standards are the following:

- **EN 55032:2015+A1 2020 Class B & EN 55035:2017+A11 2020.**

The RA6W1 QFN66 Daughterboard (RTK7WBA6W1S02000BK) has been tested and found to comply with the standards harmonized with the regulations listed below according to UKCA-Radio Equipment Regulations 2017-CHAPTER 1 6(1)(a) Health, 6(1)(b) and 6(2). The applicable standards are:

- **Radio:** EN 300 328 V2.2.2 (2019-07), EN 301 893 V2.1.1 (2017-05), EN 300 440 V2.2.1 (2018-07)
- **Health:** EN IEC 62311:2020, EN 50665:2017, EN 50385:2017
- **Safety:** IEC 62368-1:2014, EN 62368-1:2014+A11:2017, BS EN 62368-1:2014+A11:2017
- **EMC:** EN 301 489-1 V2.2.3 (2019-11) Class B, EN 301 489-17 V3.3.1 (2024-09), EN 55032:2015+A1:2020 Class B, EN 55035:2017+A11:2020.

Simplified Declaration of Conformity

Hereby, Renesas Design Inc. declares that radio type equipment RA6W1 QFN66 Daughterboard with product number **RTK7WBA6W1S02000BK** is in compliance with Radio Equipment Regulations 2017. RA6W1 Main Board with part number **RTK7WBA6W1S01000BK** is in compliance with **EMC Directive (2014/30/EU)**. Therefore, RA6W1 Evaluation Kit with part number **RTK7WBA6W1S04000BK**, consisting of the two above-mentioned boards is compliance with UK Directives. The full texts of the UK declaration of conformity are available at the following internet address: www.renesas.com.

This equipment complies with UK radiation exposure limits set forth for an uncontrolled environment. This equipment should be installed and operated at a minimum distance of 20cm between the radiator and your body.

- 2412-2472MHz: 20 dBm
- 5180-5240MHz: 23 dBm
- 5260-5320MHz: 23 dBm
- 5500-5700: 23 dBm
- 5745-5825MHz: 13.98 dBm

The device is restricted to indoor use only when operating in the 5150 to 5350 MHz frequency range.



Figure 86. UK Directive Labels

B.1.4 MIC (Japan)

The RA6W1 QFN66 Daughterboard (RTK7WBA6W1S02000BK) has received type certification as required to conform to the technical standards regulated by the Ministry of Internal Affairs and Communications (MIC) of Japan pursuant to the Radio Act of Japan.

Model no: RTK7WBA6W1S02000BK, MIC ID: 020-250327

W52/W53屋内使用限定ただし登録局に接続される場合は除く

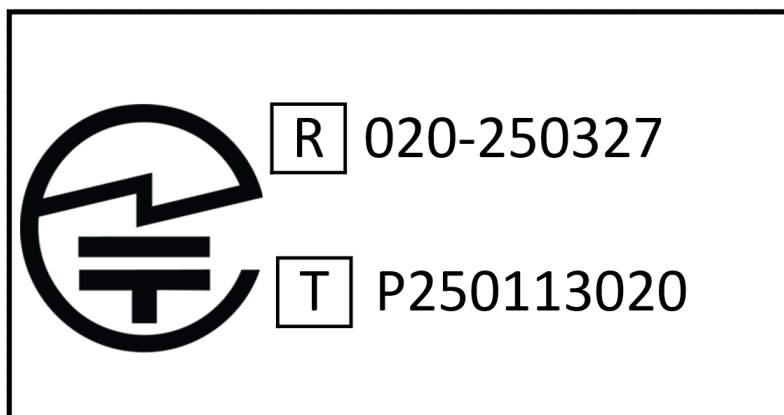

Figure 87. RA6W1 QFN66 Daughterboard (Model Number: RTK7WBA6W1S02000BK) GITEKI mark label

B.2 RA6W2 Evaluation Kit

Renesas RA6W2 Evaluation Kit conforms to laws and regulations that are described in the following subsections.

B.2.1 FCC Notice (Applicable to Evaluation Kits not FCC-Approved)

This kit is designed to allow product developers to evaluate electronic components, circuitry, or software associated with the kit to determine whether to incorporate such items in a finished product and software developers to write software applications for use with the [end product](#). This kit is not a finished product and when assembled may not be resold or otherwise marketed unless all required FCC equipment authorizations are first obtained. [Operation](#) is subject to the condition that this product not cause [harmful interference](#) to licensed [radiostations](#) and that this product accept [harmful interference](#). Unless the assembled kit is designed to operate under part 15, part 18 or part 95 of this chapter, the operator of the kit must operate under the authority of an FCC license holder or must secure an experimental authorization under part 5 of this chapter.

B.2.2 CE (Radio Equipment Directive 2014/53/EU (RED)) – (Europe)

The RA6W1 Main Board (RTK7WBA6W1S01000BK) has been tested and found to comply with **EMC Directive (2014/30/EU)** for electromagnetic compatibility. Applicable standards are the following:

- **EN 55032:2015+A1 2020 Class B & EN 55035:2017+A11 2020.**

The RA6W2 BGA93 Daughterboard (RTK7WBA6W2S05000BK) has been tested and found to comply with RED 2014/53/EU Essential Requirements for Health, Safety, and Radio. The applicable standards are:

- **Radio:** EN 300 328 V2.2.2 (2019-07), EN 301 893 V2.1.1 (2017-05), EN 300 440 V2.2.1 (2018-07)
- **Health:** EN IEC 62311:2020, EN 50665:2017, EN 50385:2017
- **Safety:** IEC 62368-1:2018, EN IEC 62368-1:2020+A11:2020+AC:2020-05, BS EN 62368-1:2020+A11:2020
- **EMC:** EN 301 489-1 V2.2.3 (2019-11) Class B, EN 301 489-17 V3.3.1 (2024-09), EN 55032:2015+A1:2020 Class B, EN 55035:2017+A11:2020.

Simplified Declaration of Conformity

Hereby, Renesas Design Inc. declares that radio type equipment RA6W2 BGA93 Daughterboard with product number **RTK7WBA6W2S05000BK** is in compliance with Directive 2014/53/EU. RA6W2 Main Board with part number **RTK7WBA6W1S01000BK** is in compliance with **EMC Directive (2014/30/EU)**. Therefore, RA6W2 Evaluation Kit with part number **RTK7WKA6W2S03000BK**, consisting of the two above-mentioned boards is compliance with EU Directives. The full texts of the EU declaration of conformity are available at the following internet address: www.renesas.com

This equipment complies with EU radiation exposure limits set forth for an uncontrolled environment. This equipment should be installed and operated at a minimum distance of 20cm between the radiator and your body.

- 2402-2480MHz (LE): 20 dBm
- 2412-2472MHz: 20 dBm
- 5180-5240MHz: 23 dBm
- 5260-5320MHz: 23 dBm
- 5500-5700: 23 dBm
- 5745-5825MHz: 13.98 dBm.

The device is restricted to indoor use only when operating in the 5150 to 5350 MHz frequency range.

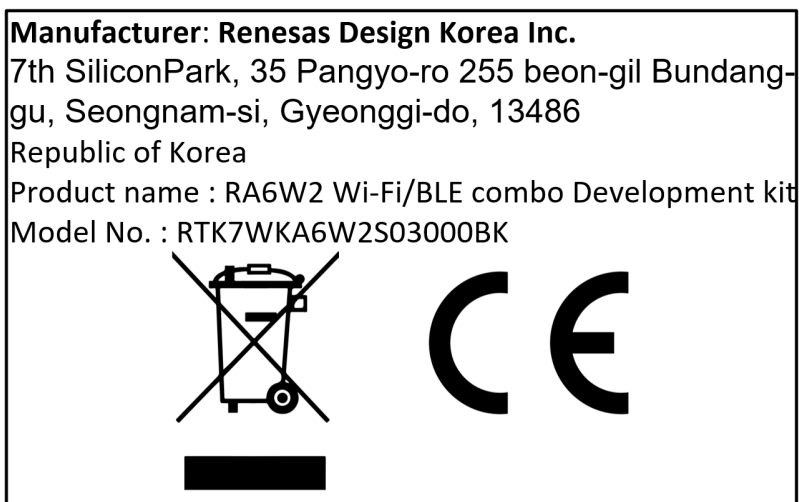

Figure 88. EU Directive Labels

B.2.3 UKCA (UK)

The RA6W2 Main Board (RTK7WBA6W1S01000BK) has been tested and found to comply with **EMC Directive (2014/30/EU)** for electromagnetic compatibility. Applicable standards are the following:

- **EN 55032:2015+A1 2020 Class B & EN 55035:2017+A11 2020.**

The RA6W2 BGA93 Daughterboard (RTK7WBA6W2S05000BK) has been tested and found to comply with the standards harmonized with the regulations listed below according to UKCA-Radio Equipment Regulations 2017-CHAPTER 1 6(1)(a) Health, 6(1)(b) and 6(2). The applicable standards are:

- **Radio:** EN 300 328 V2.2.2 (2019-07), EN 301 893 V2.1.1 (2017-05), EN 300 440 V2.2.1 (2018-07)
- **Health:** EN IEC 62311:2020, EN 50665:2017, EN 50385:2017

- **Safety:** IEC 62368-1:2018, EN IEC 62368-1:2020+A11:2020+AC:2020-05, BS EN 62368-1:2020+A11:2020
- **EMC:** EN 301 489-1 V2.2.3 (2019-11) Class B, EN 301 489-17 V3.3.1 (2024-09), EN 55032:2015+A1:2020 Class B, EN 55035:2017+A11:2020.

Simplified Declaration of Conformity

Hereby, Renesas Design Inc. declares that radio type equipment RA6W2 BGA93 Daughterboard with product number **RTK7WBA6W2S05000BK** is in compliance with Radio Equipment Regulations 2017. RA6W2 Main Board with part number **RTK7WBA6W1S01000BK** is in compliance with **EMC Directive (2014/30/EU)**. Therefore, RA6W2 Evaluation Kit with part number **RTK7WKA6W2S03000BK**, consisting of the two above-mentioned boards is compliance with UK Directives. The full texts of the UK declaration of conformity are available at the following internet address: www.renesas.com.

This equipment complies with UK radiation exposure limits set forth for an uncontrolled environment. This equipment should be installed and operated at a minimum distance of 20 cm between the radiator and your body.

- 2402-2480MHz (LE): 20 dBm
- 2412-2472MHz: 20 dBm
- 5180-5240MHz: 23 dBm
- 5260-5320MHz: 23 dBm
- 5500-5700: 23 dBm
- 5745-5825MHz: 13.98 dBm.

The device is restricted to indoor use only when operating in the 5150 to 5350 MHz frequency range.

<p>Imported by: Renesas Electronics Operations Services Limited Dukes Meadow, Millboard Road, Bourne End, SL8 5FH, United Kingdom Manufacturer: Renesas Design Korea Inc. 7th SiliconPark, 35 Pangyo-ro 255 beon-gil Bundang-gu, Seongnam-si, Gyeonggi-do, 13486 Republic of Korea Product name : RA6W2 Wi-Fi/BLE combo Development kit Model No. : RTK7WKA6W2S03000BK</p>	
--	---

Figure 89. UK Directive Labels

B.2.4 MIC (Japan)

The RA6W2 BGA93 Daughterboard (RTK7WBA6W2S05000BK) has received type certification as required to conform to the technical standards regulated by the Ministry of Internal Affairs and Communications (MIC) of Japan pursuant to the Radio Act of Japan.

Model no: RTK7WBA6W2S05000BK, MIC ID: 020-260132

W52/W53屋内使用限定ただし登録局に接続される場合は除く

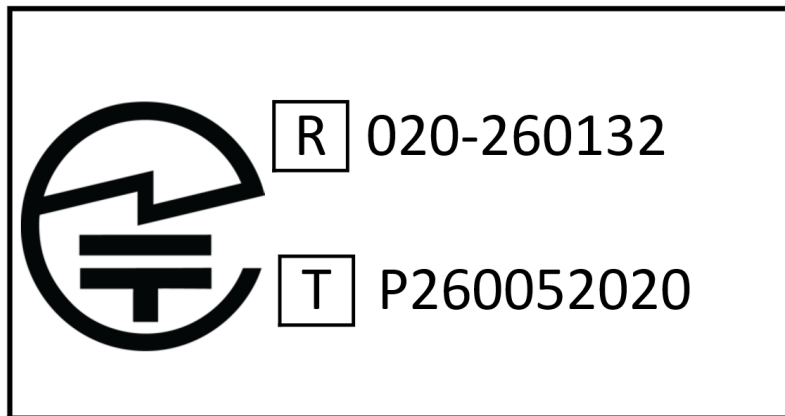

Figure 90. RA6W2 BGA93 Daughterboard (Model Number: RTK7WBA6W2S05000BK) GITEKI mark label

B.3 RRQ610xx Evaluation Kit

Renesas RRQ610xx Evaluation Kit conforms to laws and regulations that are described in the following subsections.

B.3.1 FCC Notice (Applicable to Evaluation Kits not FCC-Approved)

This kit is designed to allow product developers to evaluate electronic components, circuitry, or software associated with the kit to determine whether to incorporate such items in a finished product and software developers to write software applications for use with the [end product](#). This kit is not a finished product and when assembled may not be resold or otherwise marketed unless all required FCC equipment authorizations are first obtained. [Operation](#) is subject to the condition that this product does not cause [harmful interference](#) to licensed [radiostations](#) and that this product accept [harmful interference](#). Unless the assembled kit is designed to operate under part 15, part 18 or part 95 of this chapter, the operator of the kit must operate under the authority of an FCC license holder or must secure an experimental authorization under part 5 of this chapter.

The EVK integrates Renesas RRQ610x1 radio modules that are pre-certified for operation in multiple regulatory domains. Full regulatory approval details, identification numbers, and operating conditions are provided in the respective module datasheets.

For detailed regulatory approvals, certification identifiers, antenna restrictions, RF exposure requirements, and labeling instructions, see:

- *RRQ61001 Module Datasheet, Section "Regulatory Information"*
- *RRQ61051 Module Datasheet, Section "Regulatory Information"*.

8. Revision History

Revision	Date	Description
1.12	June 24, 2026	Updated the EK-RA6W1 Motherboard (565-11-x) - RTK7WBA6W1S01000BK section.
1.11	May 29, 2026	Updated the Headers and jumper settings of the EVK motherboard table in the Evaluation Kits Hardware Components section. Updated the EK- Motherboard (565-11-x) - RTK7WBA6W1S01000BK and RTK7WBA6W1S02000BK-QFN Evaluation Daughterboard (565-07-x) sections. Added the Regulatory Information appendix.
1.10	Nov 24, 2025	Modified the Power Measurements Setup and the SDIO Interface sections. Updated Figure 1, 3, 5-7.
1.09	Oct 13, 2025	Added measurements setup. Added note for J403.
1.08	Sept 8, 2025	Updated figures.
1.07	Aug 28, 2025	Updated figures.
1.06	Aug 15, 2025	Updated figures.
1.00	Mar 13, 2025	First version.

IMPORTANT NOTICE AND DISCLAIMER

RENESAS ELECTRONICS CORPORATION AND ITS SUBSIDIARIES (“RENESAS”) PROVIDES TECHNICAL SPECIFICATIONS AND RELIABILITY DATA (INCLUDING DATASHEETS), DESIGN RESOURCES (INCLUDING REFERENCE DESIGNS), APPLICATION OR OTHER DESIGN ADVICE, WEB TOOLS, SAFETY INFORMATION, AND OTHER RESOURCES “AS IS” AND WITH ALL FAULTS, AND DISCLAIMS ALL WARRANTIES, EXPRESS OR IMPLIED, INCLUDING, WITHOUT LIMITATION, ANY IMPLIED WARRANTIES OF MERCHANTABILITY, FITNESS FOR A PARTICULAR PURPOSE, OR NON-INFRINGEMENT OF THIRD-PARTY INTELLECTUAL PROPERTY RIGHTS.

These resources are intended for developers who are designing with Renesas products. You are solely responsible for (1) selecting the appropriate products for your application, (2) designing, validating, and testing your application, and (3) ensuring your application meets applicable standards, and any other safety, security, or other requirements. These resources are subject to change without notice. Renesas grants you permission to use these resources only to develop an application that uses Renesas products. Other reproduction or use of these resources is strictly prohibited. No license is granted to any other Renesas intellectual property or to any third-party intellectual property. Renesas disclaims responsibility for, and you will fully indemnify Renesas and its representatives against, any claims, damages, costs, losses, or liabilities arising from your use of these resources. Renesas' products are provided only subject to Renesas' Terms and Conditions of Sale or other applicable terms agreed to in writing. No use of any Renesas resources expands or otherwise alters any applicable warranties or warranty disclaimers for these products.

(Disclaimer Rev.1.01)

Corporate Headquarters

TOYOSU FORESIA, 3-2-24 Toyosu
Koto-ku, Tokyo 135-0061, Japan

www.renesas.com

Trademarks

Renesas and the Renesas logo are trademarks of Renesas Electronics Corporation. All trademarks and registered trademarks are the property of their respective owners.

Contact Information

For further information on a product, technology, the most up-to-date version of a document, or your nearest sales office, please visit www.renesas.com/contact-us/

© 2026 Renesas Electronics Corporation. All rights reserved.