

OB1203SD-BT2-EVK

Evaluation Kit for Heart Rate, SpO₂, and Respiration Rate

The OB1203SD-BT2-EVK evaluation kit for Heart Rate, SpO₂, and Respiration Rate uses Renesas' highly integrated OB1203 biosensor for reflective photoplethysmography.

With the provided algorithm, the kit can determine Heart Rate, Oxygen Saturation (SpO₂), and Respiration Rate. Data can be monitored locally by connecting a USB cable between the EVK and a computer and using a terminal program. Data is also sent by a wireless Bluetooth (BLE) link and available for monitoring using the Renesas OB1203 Web App running on a Windows™ v10 or later PC.

The design incorporates a Dialog DA14531MOD SmartBond TINY™ Module for MCU+BLE capability and a Renesas ISL9111 DC-DC boost converter.

Functions

- Collects data from Renesas OB1203 sensor module through I2C communication
- Calculates the oxygen saturation, pulse, and respiration rate using the provided algorithm
- Reports oxygen saturation, pulse, and respiration rate raw data and tabular summary values plus battery level
- Boosts battery voltage to system's voltage needs

Target Devices

- MCU+BLE: Dialog DA14531MOD module
- Sensor: OB1203 module
- Boost: ISL9111 (ISL9111EH33Z)

When applying the provided algorithm to another microcontroller, modify the program to the specifications for the target microcontroller and conduct an extensive evaluation of the modified program. Changes in analog or power supply components also must be fully evaluated.

Specifications

The OB1203SD-BT2-EVK monitors heart rate, blood oxygen saturation, and respiration rate. Battery-operated and portable, the evaluation kit is suitable for monitoring at home, during exercise, or travel.

- Operating voltage: 3.0V (AAA battery × 2)
- Measurement range: Oxygen saturation: 70% to 100%
- Pulse rate: 25 to 200 bpm
- Operating temperature: -40 to 85°C
- Operating humidity: 5 to 99% RH (No condensate water)

Contents

1. Functional Description	3
1.1 DA14531MOD SmartBond TINY™ MCU+BLE Module	3
1.1.1 DA14531MOD Key Features	5
1.2 OB1203 Photoplethysmography Sensor	6
1.2.1 OB1203 Key Features	6
1.3 ISL9111 DC-DC Boost	7
1.3.1 ISL9111 Key Features	7
1.4 Setup and Configuration	8
2. Board Design	9
2.1 Functional Description	9
2.2 Layout	9
2.3 Schematic	10
2.4 Bill of Materials	12
2.5 PCB Fabrication	13
3. Custom Programming	14
4. Renesas Algorithm	17
4.1 Main Process	17
4.2 OB1203 Module Routines	18
5. Ordering Information	19
6. Notice	19
7. Revision History	19

Figures

Figure 1. DA14531 SmartBond TINY Module Block Diagram	3
Figure 2. DA14531MOD (16) Pin Configuration	4
Figure 3. OB1203 Typical Application Circuit	6
Figure 4. ISL9111 Typical Application Circuit	7
Figure 5. OB123SD-BT2-EVK Measurement	8
Figure 6. OB1203SD-BT2-EVK Board Layout	9
Figure 7. OB1203SD-BT2-EVK Schematic – Page 1	10
Figure 8. OB1203SD-BT2-EVK Schematic – Page 2	11
Figure 9. OB1203SD-BT2-EVK PCB Fabrication Drawing	13
Figure 10. OB1203SD-BT2-EVK with MCU Programming Adapter	14
Figure 11. Smart Snippets Toolbox for Loading Initial Multi-image Code to the HW DUT	15
Figure 12. Smart Snippets Toolbox for Loading Initial Multi-image Code to the DUT	15
Figure 13. Smart Snippets Toolbox for Loading Initial Multi-image Code to the DUT	16
Figure 14. Main Processing Routine	17
Figure 15. User Initialization Routine	17
Figure 16. PPG Measurement Routine	18

1. Functional Description

1.1 DA14531MOD SmartBond TINY™ MCU+BLE Module

The SmartBond TINY™ Module is based on the Dialog Semiconductor DA14531 SoC configured in buck mode. With an integrated 1Mbit flash, 32MHz XTAL and a printed antenna, the module enables a faster time to market at reduced development costs.

The module is comprised of the following (see also Figure 1):

- 1Mbit SPI FLASH
- 32MHz XTAL
- 2 decoupling capacitors
- A power inductor
- A CLC filter and matching components for the printed antenna

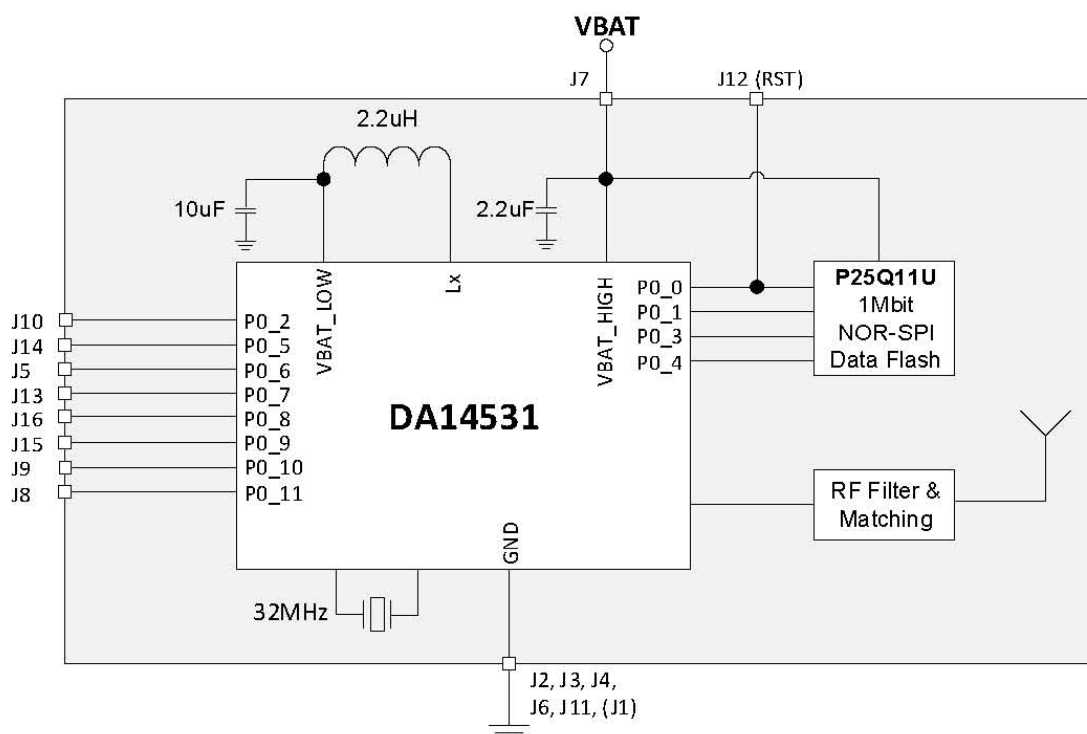
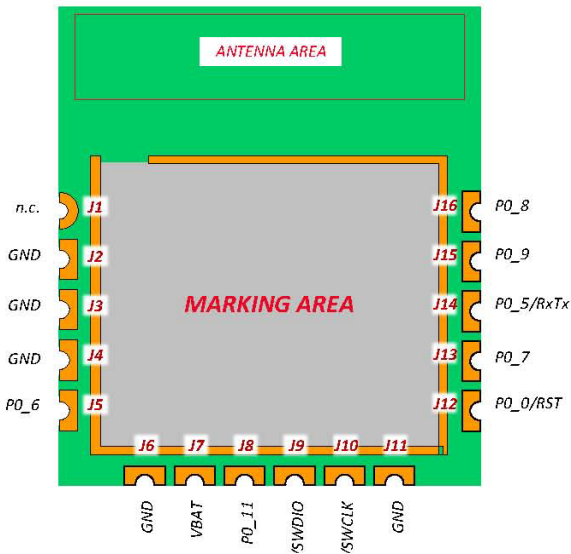

Figure 1. DA14531 SmartBond TINY Module Block Diagram

Figure 2 shows the pin configuration of the DA14531MOD (32-pin products).



Pin #	Pin Name	Type	Reset State	Description
J1	n.c			Not internally connected. Recommended to be connected to ground externally
J2	GND	GND		Ground
J3	GND	GND		Ground
J4	GND	GND		Ground
J5	P0_6	DIO (Type A) Note 1	I-PD	INPUT/OUTPUT with selectable pull up/down resistors. Pull-down enabled during and after reset. General purpose I/O port bit or alternate function nodes. Contains state retention mechanism during power down
J6	GND	GND		Ground

J7	VBAT	PWR		POWER. Battery connection. IO supply
J8	P0_11	DIO (Type A)	I-PD	INPUT/OUTPUT with selectable pull up/down resistors. Pull-down enabled during and after reset. General purpose I/O port bit or alternate function nodes. Contains state retention mechanism during power down
J9	P0_10	DIO (Type A)	I-PD	INPUT/OUTPUT with selectable pull up/down resistors. Pull-down enabled during and after reset. General purpose I/O port bit or alternate function nodes. Contains state retention mechanism during power down
	SWDIO			INPUT/OUTPUT. SW Data input/output. Bidirectional data and control communication (by default)
J10	P0_2	DIO (Type B)	I-PD	INPUT/OUTPUT with selectable pull up/down resistors. Pull-down enabled during and after reset. General purpose I/O port bit or alternate function nodes. Contains state retention mechanism during power-down
	SWCLK			INPUT SW clock signal (by default)
J11	GND	GND		Ground

J12	P0_0	DIO (Type B) Note 2	I-PD	INPUT/OUTPUT with selectable pull up/down resistors. Pull-down enabled during and after reset. General purpose I/O port bit or alternate function nodes. Contains state retention mechanism during power-down
	RST			RST active high hardware reset (default)
J13	P0_7	DIO (Type A)	I-PD	INPUT/OUTPUT with selectable pull up/down resistors. Pull-down enabled during and after reset. General purpose I/O port bit or alternate function nodes. Contains state retention mechanism during power down
J14	P0_5	DIO (Type B)	I-PD	INPUT/OUTPUT with selectable pull up/down resistors. Pull-down enabled during and after reset. General purpose I/O port bit or alternate function nodes. Contains state retention mechanism during power down

J15	P0_9	DIO (Type A)	I-PD	INPUT/OUTPUT with selectable pull up/down resistors. Pull-down enabled during and after reset. General purpose I/O port bit or alternate function nodes. Contains state retention mechanism during power down
J16	P0_8	DIO (Type A)	I-PD	INPUT/OUTPUT with selectable pull up/down resistors. Pull-down enabled during and after reset. General purpose I/O port bit or alternate function nodes. Contains state retention mechanism during power down

Note 1 There are two types of pads, namely Type A and Type B. Type A is a normal IO pad with a Schmitt trigger on input while Type B has an extra RC Filter with a cutoff frequency of 100 kHz
 Note 2 This pin is also used for the communication to the internal SPI FLASH

- I-PD is Input-Pulled Down
- I-PU is Input-Pulled Up
- DIO is Digital Input-Output
- PWR is power
- GND is Ground

Figure 2. DA14531MOD (16) Pin Configuration

1.1.1. DA14531MOD Key Features

- Bluetooth
 - Compatible with Bluetooth® v5.1, ETSI EN 300 328 and EN 300 440 Class 2 (Europe), FCC CFR47 Part 15 (US) and ARIB STD-T66 (Japan) core
 - Supports up to 3 connections
 - Dialog Semiconductor registered BD address preprogrammed in OTP
- Processing and memories
 - 16 MHz 32-bit Arm® Cortex® M0+ with SWD interface
 - 128 Kbytes internal FLASH
 - 48 Kbytes RAM
 - 144 Kbytes ROM
 - 32 Kbytes OTP
- Current Consumption
 - 2 mA RX at VBAT=3V
 - 4 mA TX at VBAT=3V and 0 dBm
 - 1.8 uA at sleep with all RAM retained
- Radio
 - Programmable RF transmit power from -19 to +2.2 dBm
 - -93 dBm receiver sensitivity
- Interfaces
 - Quadrature decoder with 3 channels
 - 4 channel 11-bit ENOB ADC
 - 2 general purpose timers with PWM
 - 9 GPIOs
 - SPI
 - 2x UART, 1wire UART support
 - I2C
- Power Management
 - Operating range (1.8 V - 3.3 V)
 - Inrush current control
- Other
 - Real Time Clock
 - Trimmed 32 MHz Crystal
- Packaging
 - 12.5 mm × 14.5 mm × 2.8 mm package
- Module Software Development Kit
 - Configurable DSPS
 - Codeless v2.0
 - SDK6 support
- Module Software Tools
 - Flash/OTP programmer
 - SUOTA support
 - Battery Life Estimation
 - Data Rate Monitoring
 - Real-Time Power Profiling
 - Production Line Testing
- Standards Conformance
 - BT SIG QDID 113959
 - Europe (CE/RED) and US (FCC)
 - Canada and Japan
 - South Korea and Taiwan
 - South Africa and Brazil
 - China and Thailand

1.2 OB1203 Photoplethysmography Sensor

The OB1203 Sensor Module has a fully integrated sensor for reflective photoplethysmography (PPG), a proximity sensor (PS), and a multi-channel light sensor (LS/CS, not used in this application). The OB1203 integrates light sources, drivers, sensors, ADC, and I2C interface in a single optically optimized package.

With the provided algorithm, human heart rate (HR), oxygen saturation (SpO₂), and respiration rate are determined.

The following figure shows the typical application circuit of the OB1203.

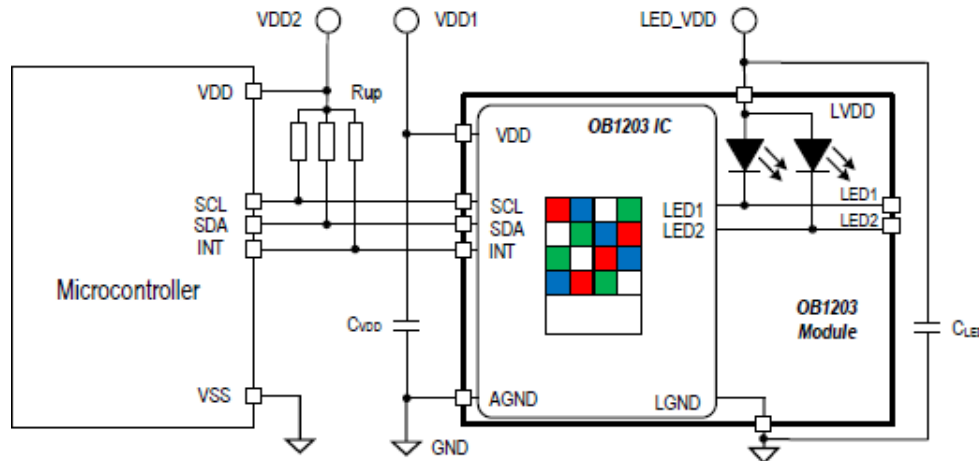

Figure 3. OB1203 Typical Application Circuit

1.2.1. OB1203 Key Features

1.2.1.1. Biosensor Features

- SpO₂ measurement behind visibly dark, IR transmissive ink
- Industry's smallest optical biosensor module
- Fully integrated and trimmed module, including two LEDs, 250mA maximum drive current, and photodetectors
- Output resolution PPG: 16 to 18 bits
- Data stored in 18-bit wide, 32-sample FIFO memory
- Integrated averaging function for higher signal-to-noise ratio (SNR) and data rate reduction
- Programmable measurement rate: up to 3200 samples per second
- High SNR

1.2.1.2. Biosensor Applications

- Sensor for heart rate, blood oxygen saturation, and respiration rate
- Secondary sensor for blood pressure
- Fitness and wellness, wearable devices

1.2.1.3. Physical Characteristics

- Highly reliable and industry-proven OSIP package with integrated cover glass for hypoallergenic products
- Wide operation temperature: -40 to +85°C
- Wide supply voltage: 1.7V to 3.6V
- Low standby current: 2μA typical
- I2C interface capable of Standard Mode or Fast Mode communication; 1.8V to 3.3V logic compatible
- Programmable level-based interrupt functions with upper and lower thresholds for extending battery life
- Industry's smallest package: 4.2 × 2 × 1.2 mm³ 14-OSIP module

1.3 ISL9111 DC-DC Boost

The ISL9111 is a high-efficiency synchronous boost converter with a 1A switch. The device provides a power supply solution for series connected ($1.5 + 1.5V = 3V$) alkaline battery-powered applications. It guarantees to supply 100mA when the output is 3.3V. High 1.2MHz switching frequency allows the use of tiny, low-profile inductors and ceramic capacitors to minimize the size of the solution.

The following figure shows the typical application circuit of the ISL9111.

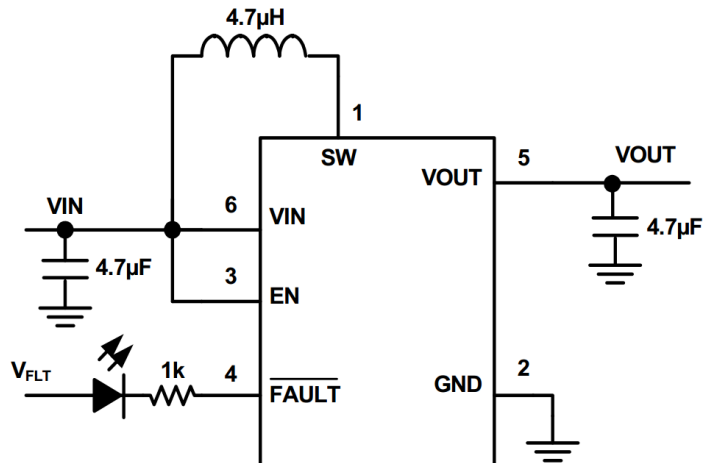

Figure 4. ISL9111 Typical Application Circuit

1.3.1. ISL9111 Key Features

- Up to 97% efficiency at typical operating conditions
- Low quiescent current: 20µA (typical)
- Logic control shutdown ($I_q < 1\mu A$)
- Output disconnect during shutdown
- Skip Mode under light load condition
- Undervoltage lockout (ISL9111 only)
- Fault protection: OVP (ADJ version only), OTP, short circuit
- 6 Ld SOT-23 package

1.4 Setup and Configuration

For more information on setup and configuration, see the Renesas *OB1203SD-BT2-EVK Getting Started Guide*.

Instructions for updating Renesas supplied code using a computer and the BLE connection are discussed in “Custom Programming.”

The following figure shows the EVK with plastic finger cradle installed. The cradle optimizes the position of the finger over the OB1203 sensor.

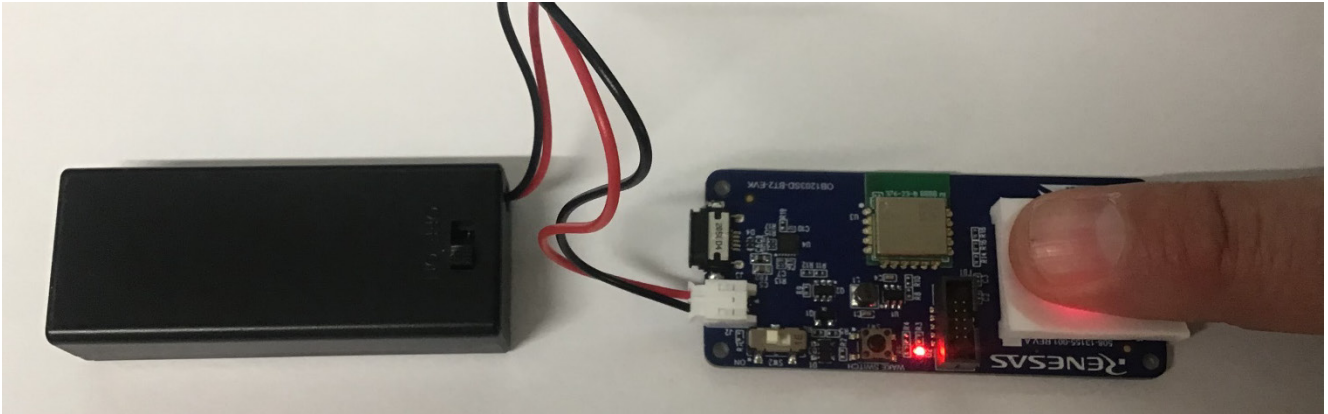

Figure 5. OB1203SD-BT2-EVK Measurement

2. Board Design

2.1 Functional Description

The OB1203 sensor interrupt triggers the MCU to read the sensor data.

The MCU determines blood oxygen saturation, heart, and respiration rate, and sends the data via I2C to the DA14531MOD.

The MCU formats data and reports results locally through a USB connection to a computer.

Data is also processed through the DA14531MOD BLE subsystem which advertises as “DLG-OB1203”.

The ISL9111 adjusts the voltage of two AAA batteries to the systems supply needs of 3.3V. The SW1 button powers on the system.

2.2 Layout

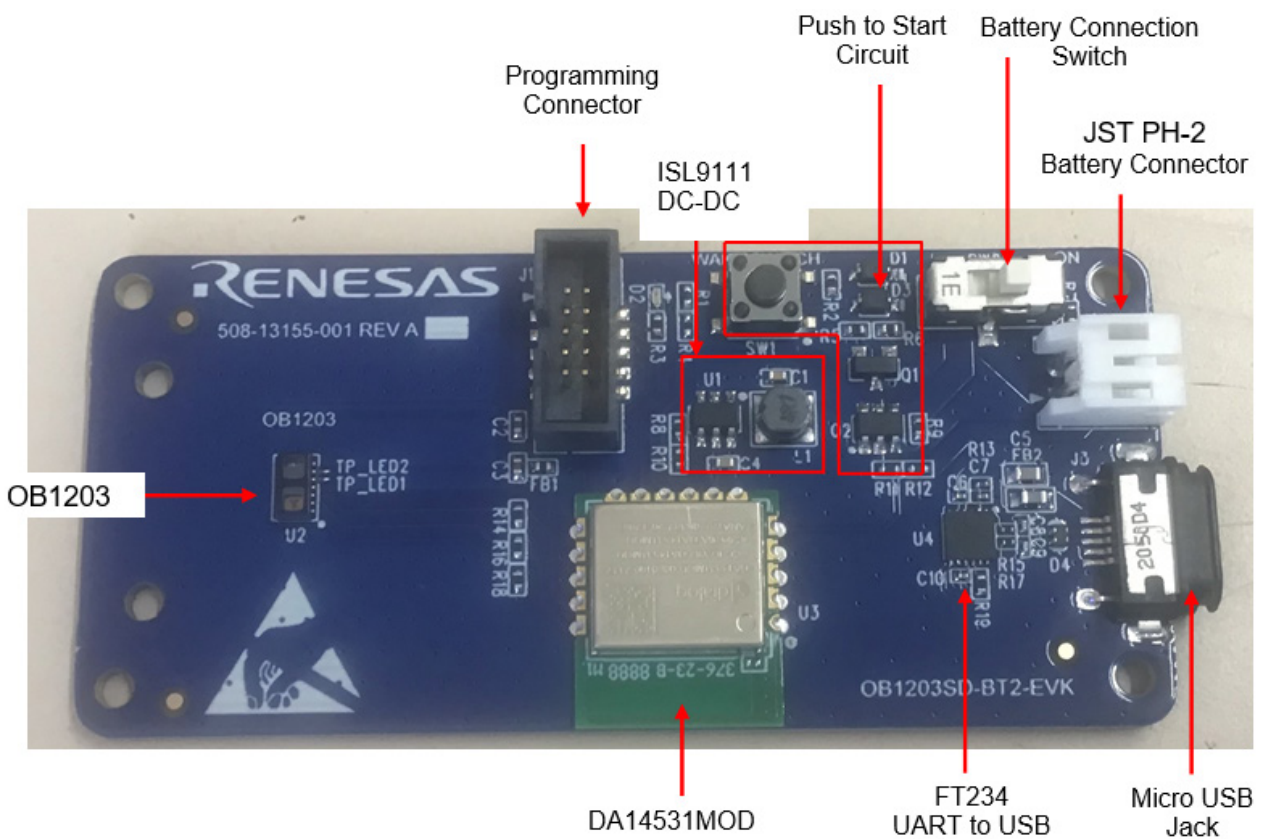

Figure 6. OB1203SD-BT2-EVK Board Layout

2.3 Schematic

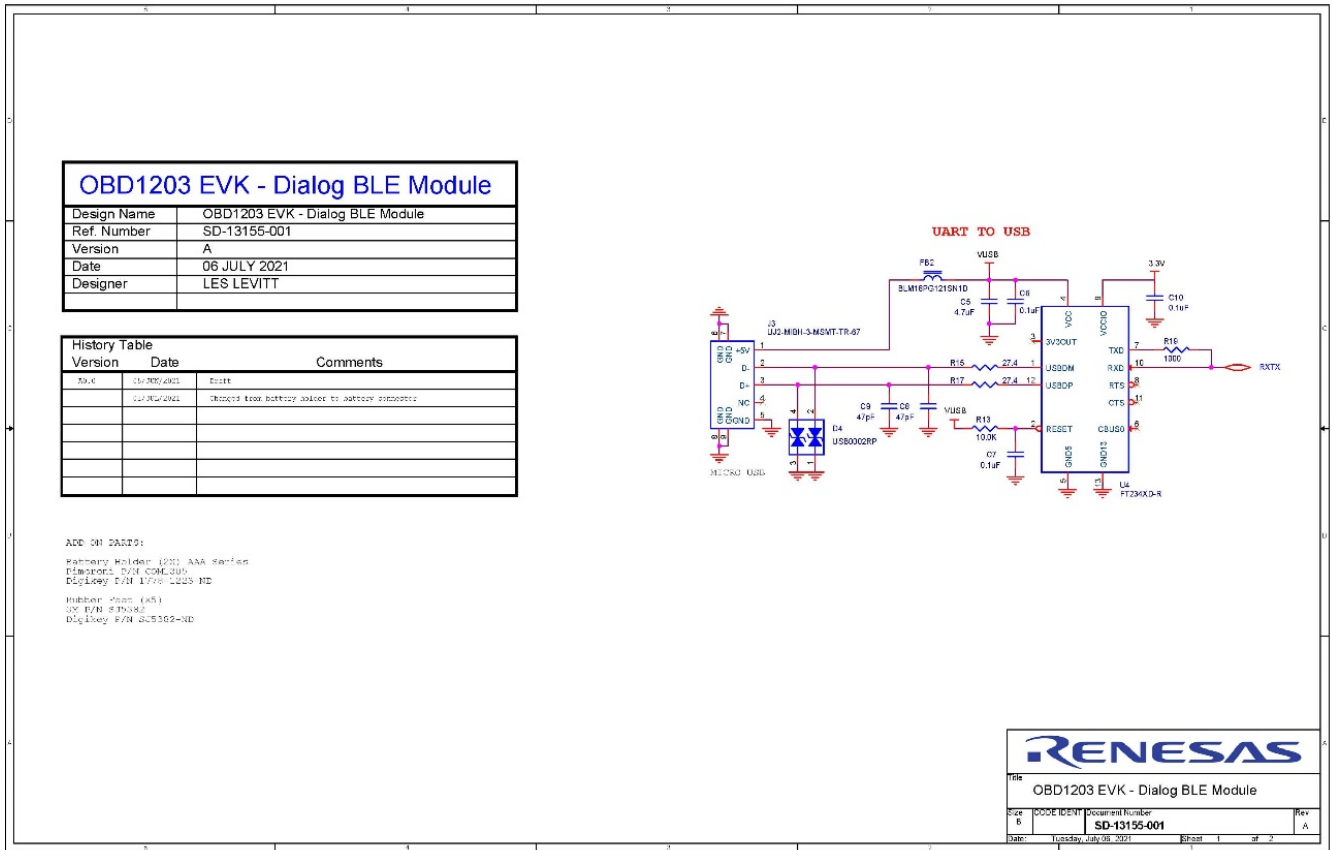

Figure 7. OB1203SD-BT2-EVK Schematic – Page 1

U4 is a UART to USB converter IC.

A single-wire UART is used for connection between the MCU and the FT234 IC.

A 1K pull-up resistor between TXD and RXD is required for the single wire UART.

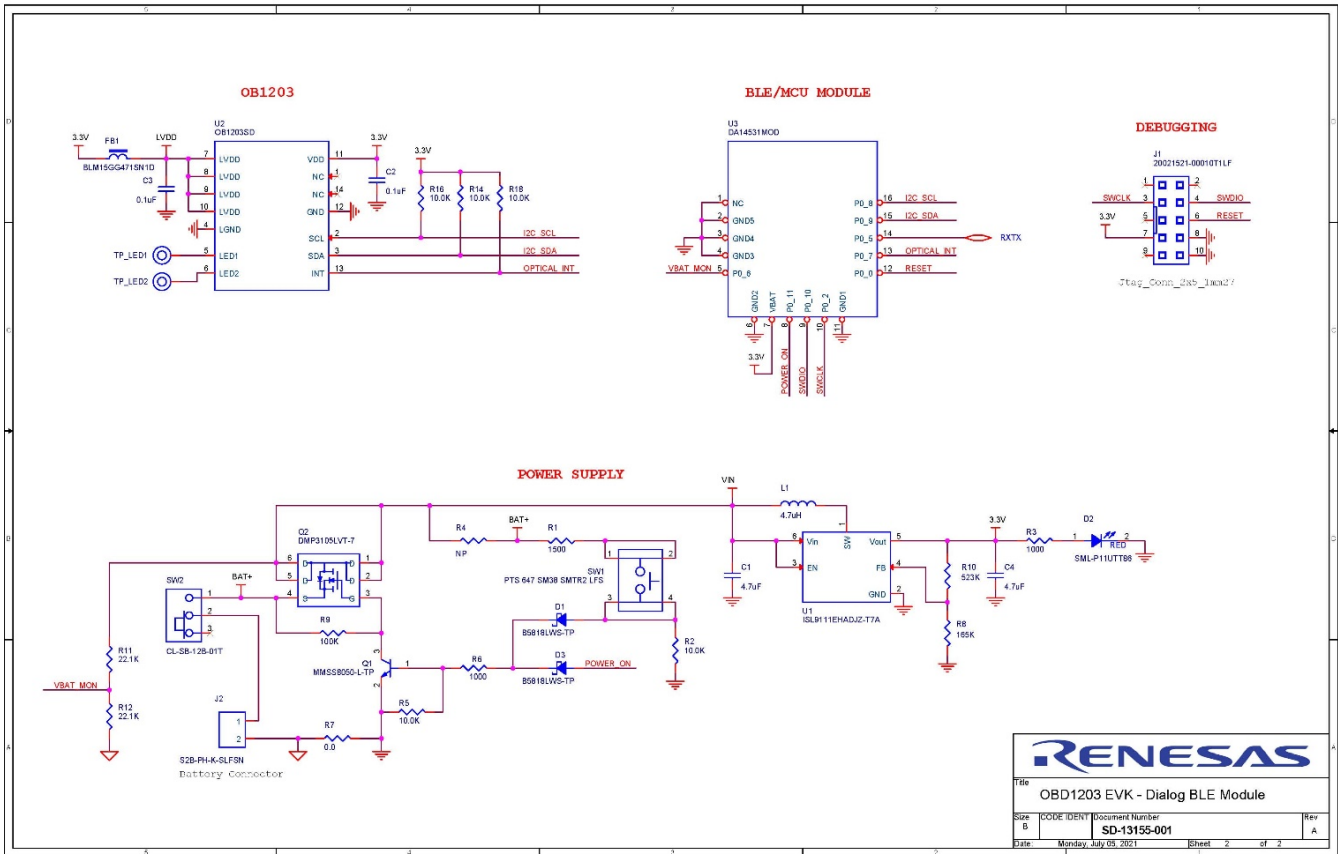

Figure 8. OB1203SD-BT2-EVK Schematic – Page 2

The power supply circuit is fed from the battery connected to J2.

The battery connector is a JST-PH2, which is an industry-standard connector for batteries.

The EVK is supplied with a battery holder (2 × AAA in series) Pimoroni P/N COM1304 = Digikey P/N 1778-1223-ND

SW2 is used to connect/disconnect the battery.

The power supply circuit monitors the state of the push button SW2.

If the switch is pressed for more than 1 second and the battery voltage (VBAT_MON checked by the MCU ADC) is above 2.5V, the MCU brings the POWER_ON net high and holds the Q2 MOSFET on to connect the battery output to the boost converter input.

The U1 ISL9111 DC-DC boost converter provides the primary voltage (3.3V) for all ICs.

A boost converter is used so that 3.3V is maintained as the battery drains to voltages lower than the nominal starting voltage when batteries are new.

The U2 OB1203 communicates to the MCU using the I2C bus.

The OPTICAL_INT net goes high when the OB1203 detects a finger near the sensor. This wakeup prompts the MCU to begin processing data.

The highly integrated U3 DA14531MOD includes the MCU which uses the Renesas supplied open-source algorithm for OB1203 measurement processing. The module also includes a globally certified BLE transceiver with on-board antenna.

2.4 Bill of Materials

Item	Qty	Part Reference	Description	Manufacturer	Manufacturer P/N
1	2	C1 C4	Capacitor 4.7uF 20% 6.3V X5R 0402	Murata	GRM155R60J475ME87J
2	2	C2 C3	Capacitor 0.1 uF 50V 10% X5R 0402	Murata	GRM155R61H104KE19D
3	1	C5	Capacitor 4.7uF 20% 10V X5R 0603	Samsung	CL10A475KP8NNNC
4	3	C6 C7 C10	Capacitor 0.1uF 10% 6.3V X5R 0201	Murata	GRM033R60J104KE19D
5	2	C8 C9	Capacitor 47pF 5% 50V NPO 0201	Murata	GRM0335C1H470JA01D
6	2	D1 D3	Diode Schottky 30V 1A B5818LWS-TP SOD323	Micro Commercial	B5818LWS-TP
7	1	D2	LED 0402 Red 50mW 20mA 1mA Test	Rohm	SML-P11UTT86
8	1	D4	Varistor Bus Protector Dual AVX USB0002RP	AVX	USB0002RP
9	1	FB1	Filter, Ferrite Bead High GHz 470ohm @ 100 MHz,300mA 0402	Murata	BLM15GG471SN1D
10	1	FB2	Filter, Ferrite Bead, 120 Ohms @ 100 MHz , 2A, 0603	Murata	BLM18EG121SN1D
11	1	J1	Conn Dual Row Header Vert SMD Keyed 2X5 1.27mm pitch	Amphenol	20021521-00010T1LF
12	1	J2	Conn Header 2 Pos 2mm R/A TH JST S2B-PH-K-S(LF)(SN)	JST	S2B-PH-K-S(LF)(SN)
13	1	J3	Conn USB Receptacle Micro-B IP67 Right Angle SMD	CUI	UJ2-MIBH-3-MSMT-TR-67
14	1	L1	Inductor SMT Power 4.7uH 1.2A 150 mohm 20% 3x2.8mm	Bourns	SDR0302-4R7ML
15	1	Q1	Transistor NPN 25V 1.5A MMSS8050-L-TP SOT-23	Micro Commercial	MMSS8050-H-TP
16	1	Q2	Transistor MOSFET DMP3105LVT-7 P-CH 30V 3A TSOT-23-6	Diodes Inc	DMP3105LVT-7
17	1	R1	Res 1500 Ohm 0402 1%		
18	5	R2 R5 R14 R16 R18	Res 10.0K Ohm 0402 1%		
19	3	R3 R6 R19	Res 1000 Ohm 0402 1%		
20	1	R4	Res NP 0402 1%		
21	1	R7	Res 0 Ohm 0402		
22	1	R8	Res 165K-Ohm 0402 1%		
23	1	R9	Res 100K Ohm 0402 1%		
24	1	R10	Res 523K-Ohm 0402 1%		
25	2	R11 R12	Res 22.1K-Ohm 0402 1%		
26	1	R13	Res 10.0K Ohm 0201 1%		
27	2	R15 R17	Res 27.4 Ohm 0201 1%		
28	1	SW1	Switch Tactile SPST NO SMD PTS 647 SM38 SMTR2 LFS 4.5 x 4.5 x 3.8m	C&K	PTS 647 SM38 SMTR2 LF
29	1	SW2	Switch Slide SPDT 200mA CL-SB-12B-01T	Nidec Copal	CL-SB-12B-01T
30	1	U1	IC Switching Reg Boost Adj 240mA ISL9111EHADJZ-T7A SOT23-6	Renesas	ISL9111EHADJZ-T7A
31	1	U2	Optical BioSensing Module OB1203SD LGA-14 4.2 x 1 x 1.2mm	Renesas	OB1203SD
32	1	U3	Module BLE 5.1 Dialog DA14531MOD 14.5 x 12.95 x 2.8mm 16Pin	Dialog	DA14531MOD
33	1	U4	IC USB Serial Basic UART FT234XD-R 12DFN	FTDI	FT234XD-R
34	1		PCB OBD1203 EVK - Dialog BLE Module		
35	1		Battery Holder 2 Cell AAA Wired with JST PH Connector	Pimoroni Ltd	COM1305
36	1		Battery Alkaline 1.5V AAA 2 pack	FDK	LR03 G6 (2S)
37	6		Bumper Cylindrical 0.25" diameter x 0.063"high Clear	Essentra	RBS-40

2.5 PCB Fabrication

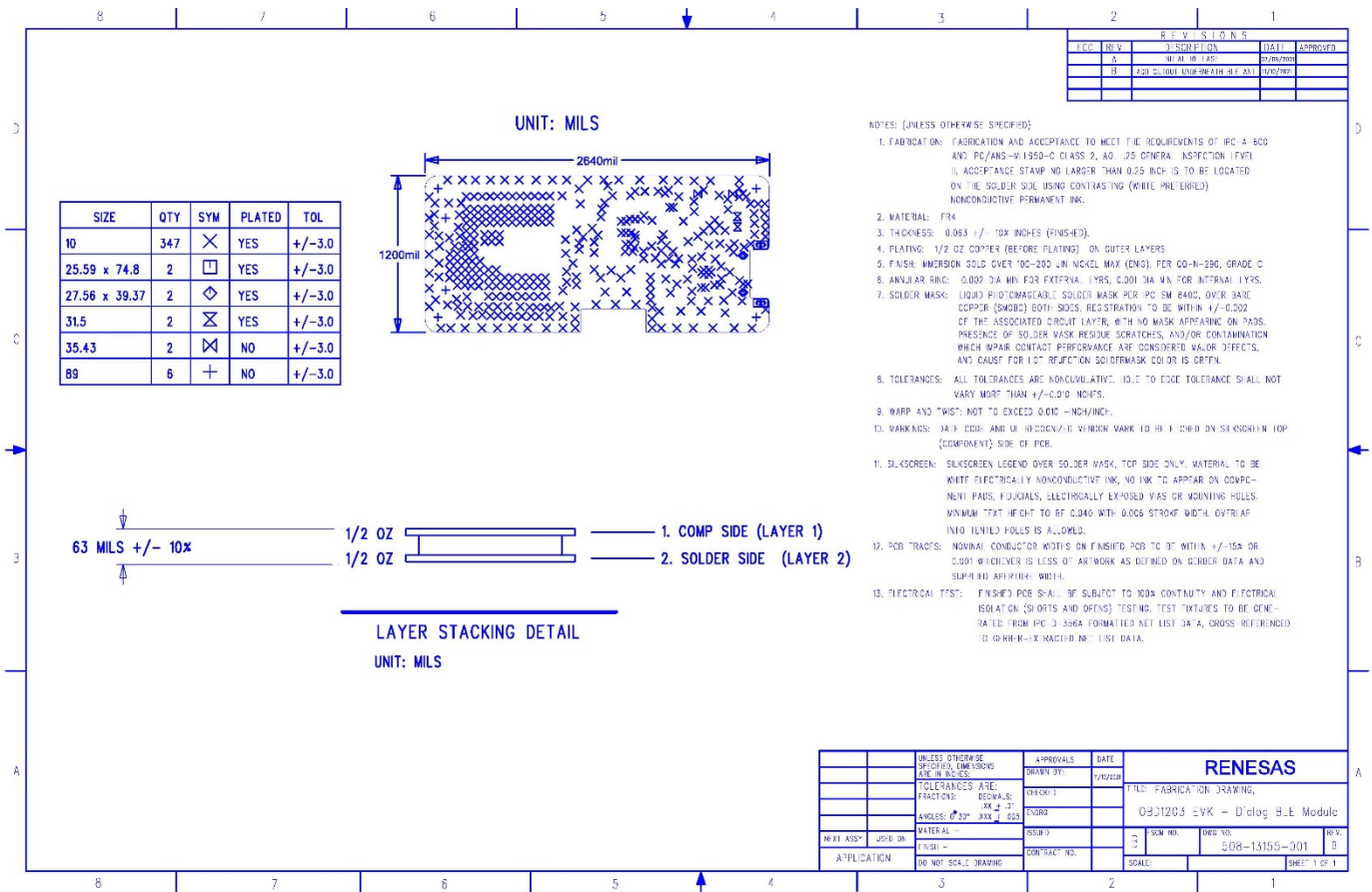

Figure 9. OB1203SD-BT2-EVK PCB Fabrication Drawing

3. Custom Programming

This section applies to users developing custom code only.

The Renesas/Dialog Keil/Smart Snippets integrated development environment (IDE) is used for custom code development.

Initial firmware that sets up the multi-image and Software Update Over the Air (SUOTA) capability is loaded into the target EVK SPI FLASH using Smart Snippets Tool Box.

Note: The RESET connection between the Dialog Communication Interface Board (CIB) / programmer PCA and the target must be disconnected for proper communication.

The following photo shows the EVK connected to a Dialog Communication Interface Board (CIB) for programming. The RESET trace was cut on the Dialog interface board at the J5 connector.

The cable between the EVK and the programming adapter is a 2 × 5 1.27 mm ARM plug-to-plug cable (Adafruit P/N 1675).

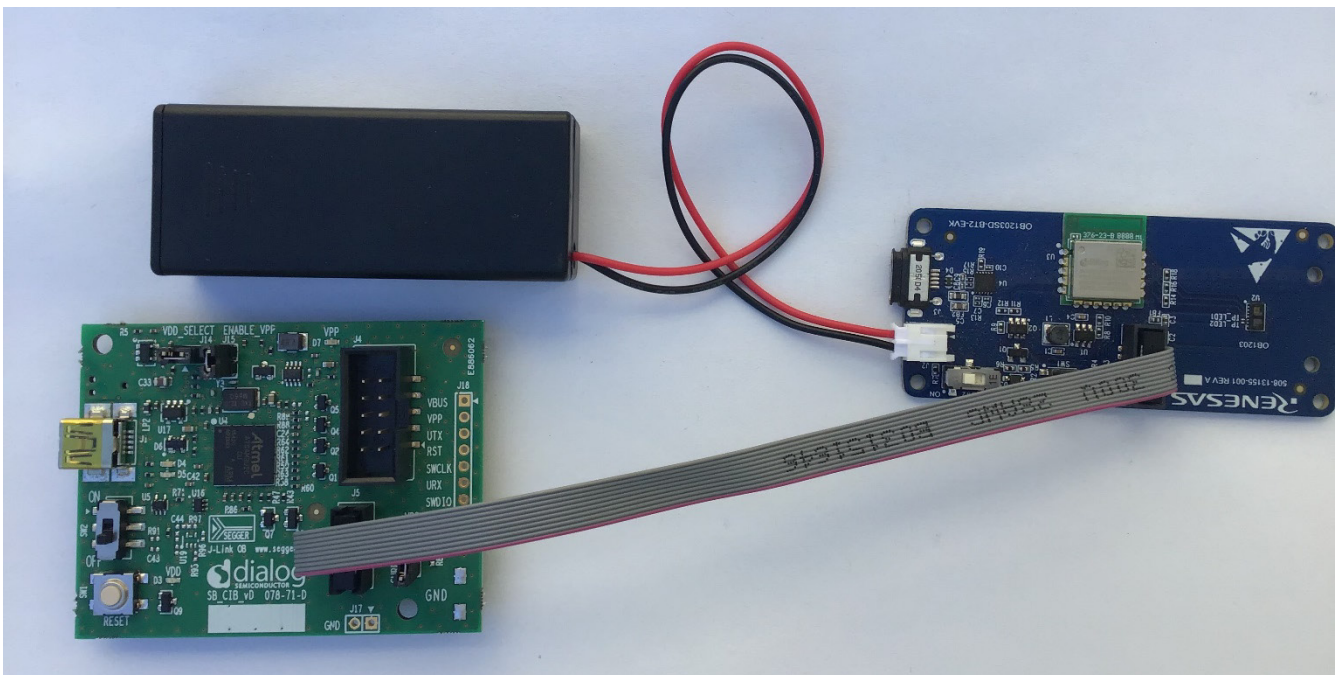

Figure 10. OB1203SD-BT2-EVK with MCU Programming Adapter

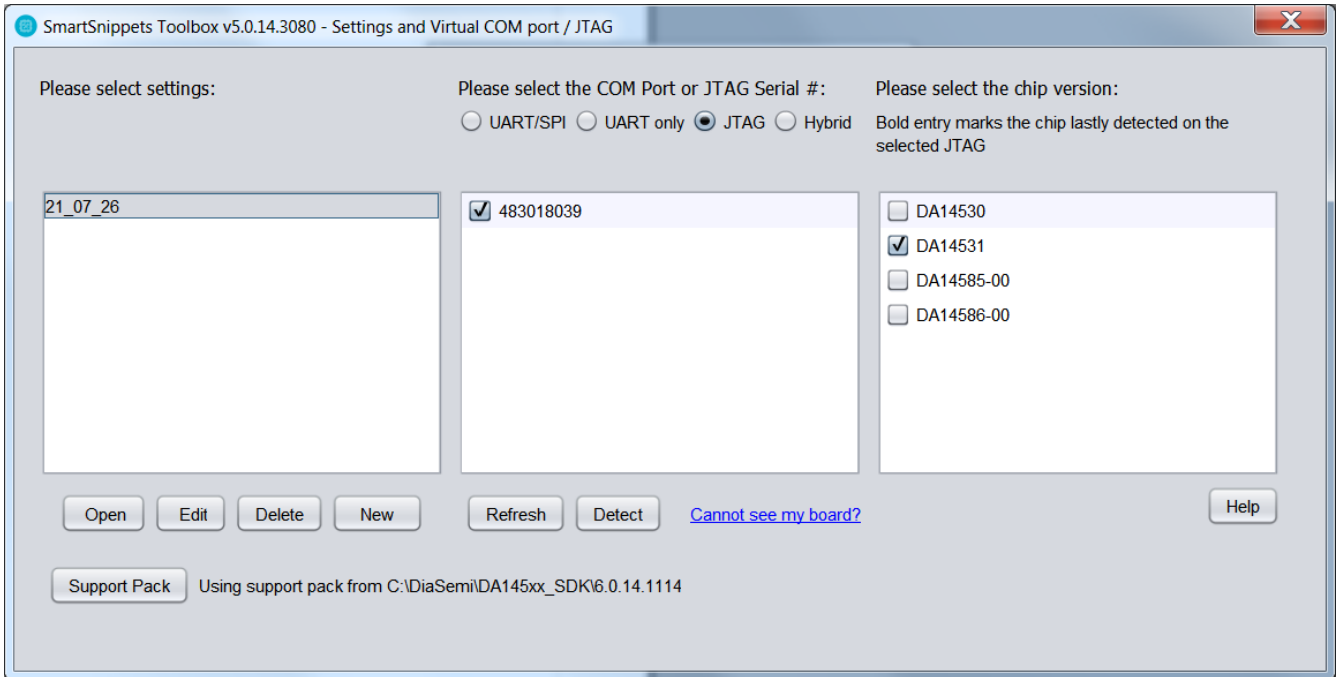

Figure 11. Smart Snippets Toolbox for Loading Initial Multi-image Code to the HW DUT

Select JTAG and set ports:

SPI-CLK = P0.4

SPI-CS = P0.1

SPI-MISO = P0.3

SPI-MOSI = P0.0

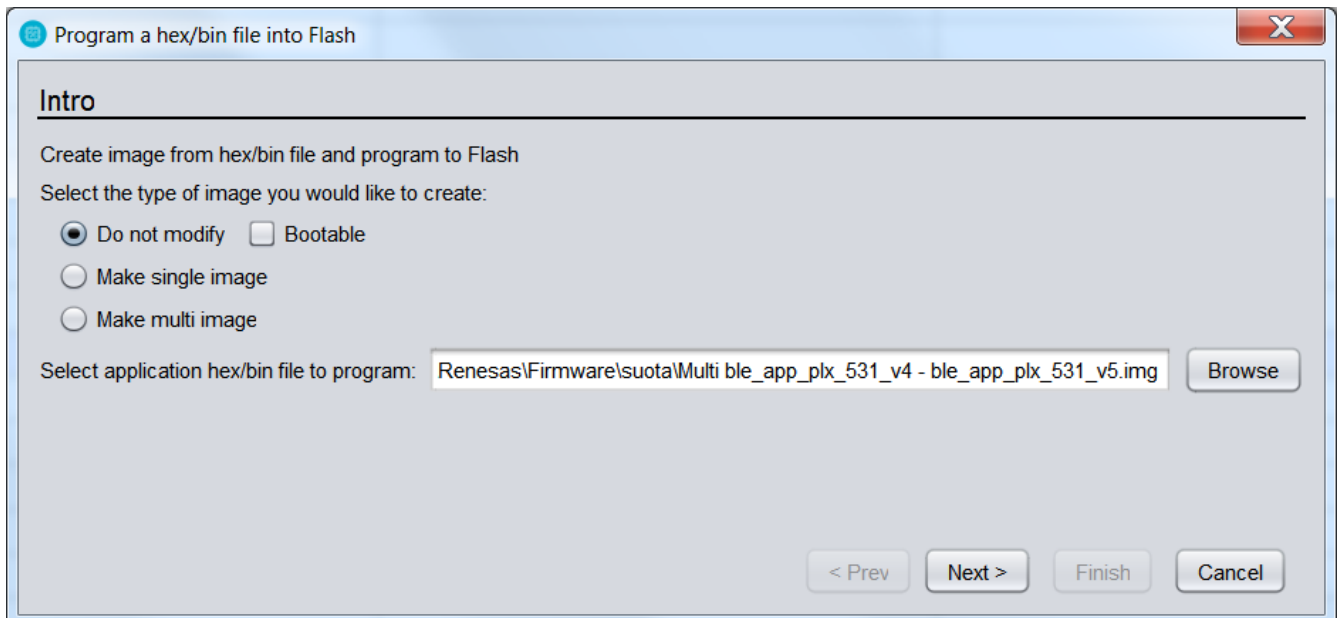

Figure 12. Smart Snippets Toolbox for Loading Initial Multi-image Code to the DUT

Bootable should be un-checked

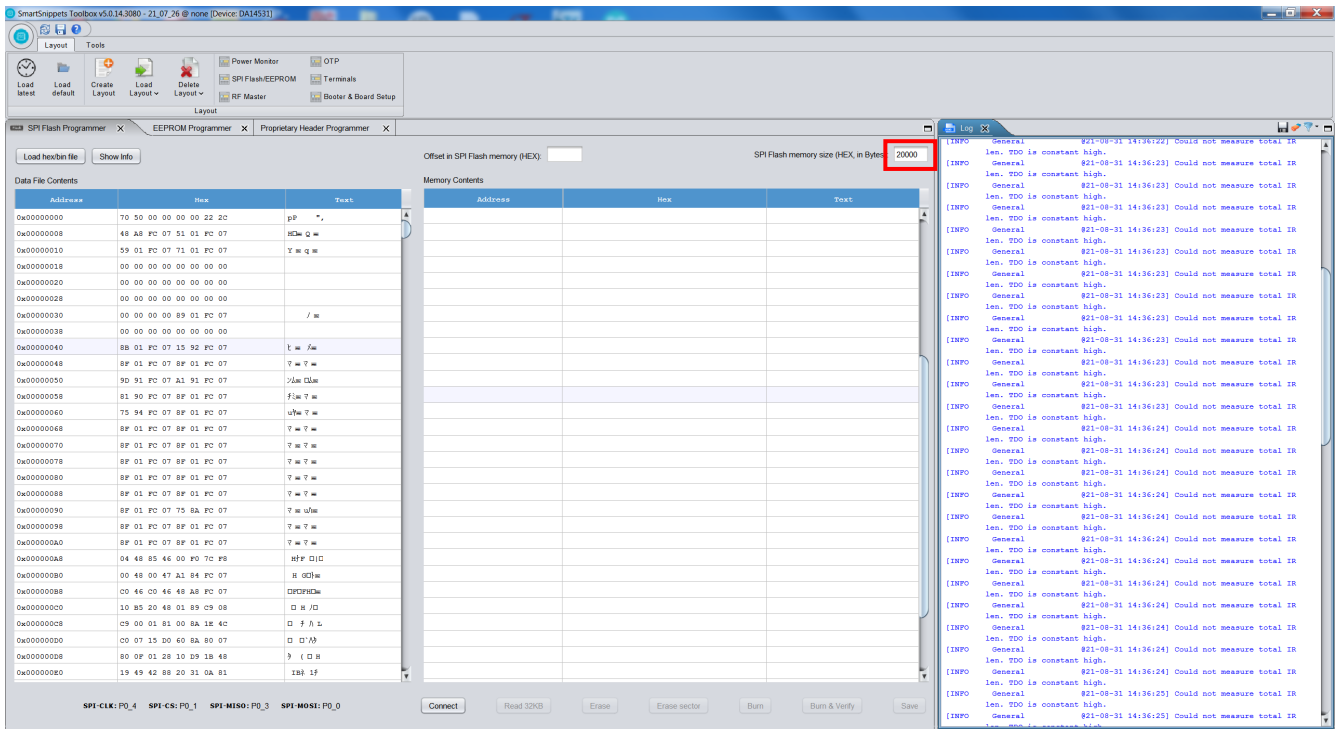

Figure 13. Smart Snippets Toolbox for Loading Initial Multi-image Code to the DUT
Set SPI FLASH memory size = 20000

4. Renesas Algorithm

4.1 Main Process

Figure 14 and Figure 15 show the flowchart for the 'main()' routine and the user initialization routine 'R_MAIN_UserInit()'.

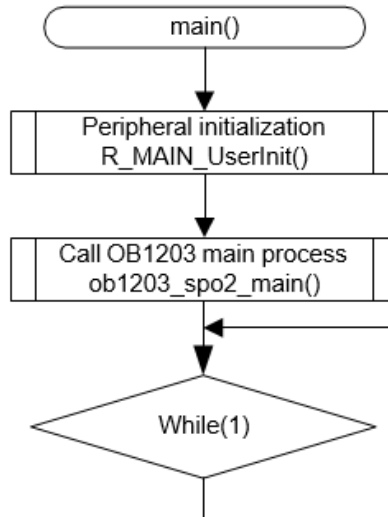

Figure 14. Main Processing Routine

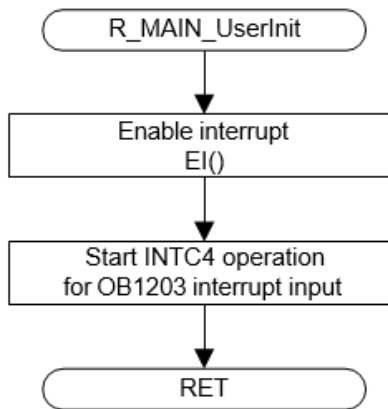

Figure 15. User Initialization Routine

4.2 OB1203 Module Routines

The following figure shows the flowchart of the oximeter measure routine.

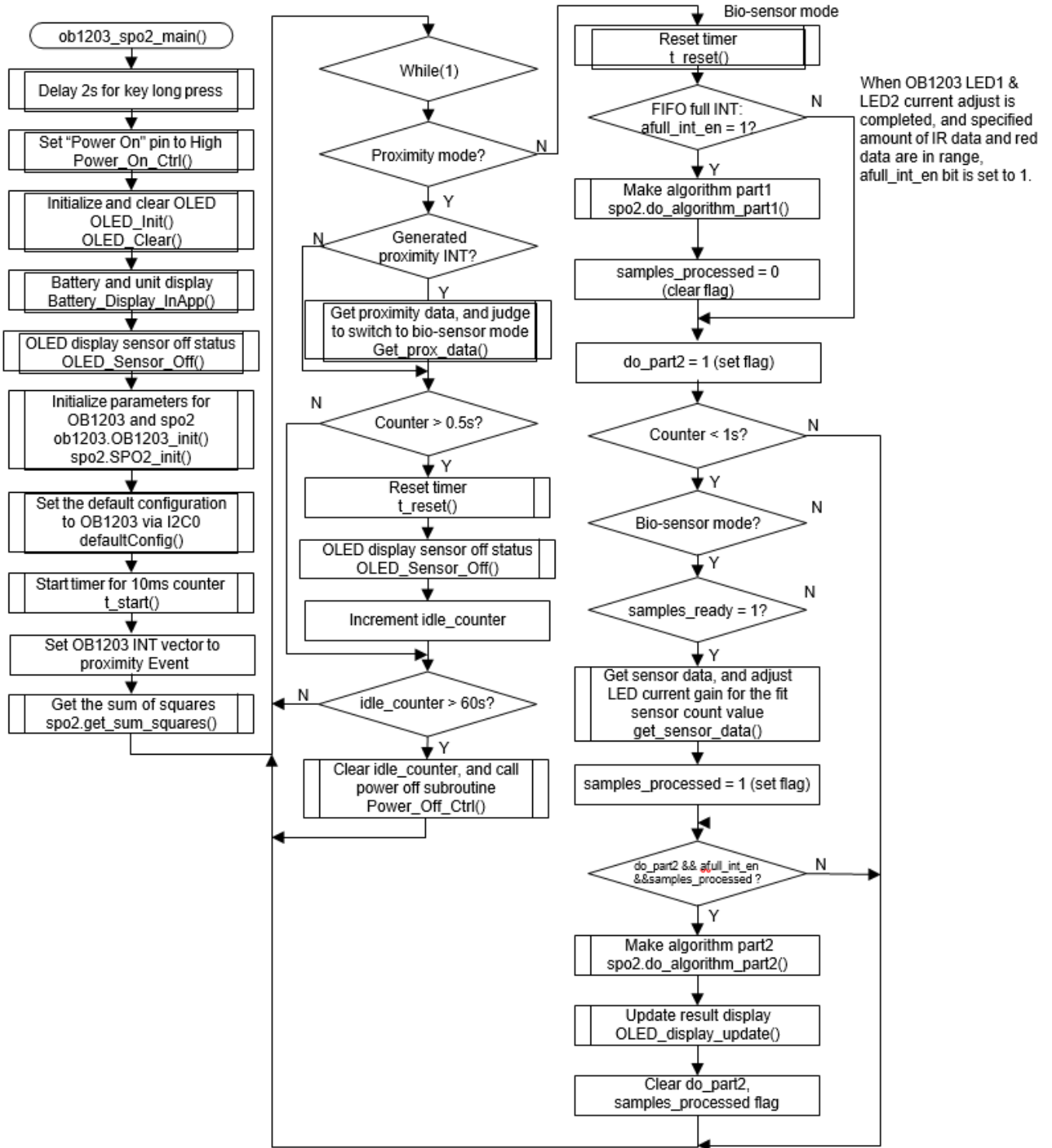

Figure 16. PPG Measurement Routine

5. Ordering Information

Part Number	Description
OB1203SD-BT2-EVK	OB1203SD-BT2-EVK Evaluation Kit

6. Notice

The OB1203SD-BT2-EVK is provided for reference, demonstration, and/or evaluation. No performance is guaranteed or warranted, nor is fitness or suitability for any medical device application claimed. Renesas will not indemnify customers using any part of the provided reference code. OEM is responsible for performance of products made using any of the provided reference code. For general questions contact Renesas. In addition, for medical devices Renesas strongly recommends to consult a medical device regulatory compliance advisor.

7. Revision History

Revision	Date	Description
1.00	Nov 19, 2021	Initial release.

IMPORTANT NOTICE AND DISCLAIMER

RENESAS ELECTRONICS CORPORATION AND ITS SUBSIDIARIES (“RENESAS”) PROVIDES TECHNICAL SPECIFICATIONS AND RELIABILITY DATA (INCLUDING DATASHEETS), DESIGN RESOURCES (INCLUDING REFERENCE DESIGNS), APPLICATION OR OTHER DESIGN ADVICE, WEB TOOLS, SAFETY INFORMATION, AND OTHER RESOURCES “AS IS” AND WITH ALL FAULTS, AND DISCLAIMS ALL WARRANTIES, EXPRESS OR IMPLIED, INCLUDING, WITHOUT LIMITATION, ANY IMPLIED WARRANTIES OF MERCHANTABILITY, FITNESS FOR A PARTICULAR PURPOSE, OR NON-INFRINGEMENT OF THIRD-PARTY INTELLECTUAL PROPERTY RIGHTS.

These resources are intended for developers who are designing with Renesas products. You are solely responsible for (1) selecting the appropriate products for your application, (2) designing, validating, and testing your application, and (3) ensuring your application meets applicable standards, and any other safety, security, or other requirements. These resources are subject to change without notice. Renesas grants you permission to use these resources only to develop an application that uses Renesas products. Other reproduction or use of these resources is strictly prohibited. No license is granted to any other Renesas intellectual property or to any third-party intellectual property. Renesas disclaims responsibility for, and you will fully indemnify Renesas and its representatives against, any claims, damages, costs, losses, or liabilities arising from your use of these resources. Renesas' products are provided only subject to Renesas' Terms and Conditions of Sale or other applicable terms agreed to in writing. No use of any Renesas resources expands or otherwise alters any applicable warranties or warranty disclaimers for these products.

(Disclaimer Rev.1.01)

Corporate Headquarters

TOYOSU FORESIA, 3-2-24 Toyosu,
Koto-ku, Tokyo 135-0061, Japan
www.renesas.com

Trademarks

Renesas and the Renesas logo are trademarks of Renesas Electronics Corporation. All trademarks and registered trademarks are the property of their respective owners.

Contact Information

For further information on a product, technology, the most up-to-date version of a document, or your nearest sales office, please visit www.renesas.com/contact-us/.