



IDT™ 89HPES3T3
PCI Express® Switch

Preliminary User Manual

February 2011

6024 Silver Creek Valley Road, San Jose, California 95138
Telephone: (800) 345-7015 • (408) 284-8200 • FAX: (408) 284-2775
Printed in U.S.A.
©2011 Integrated Device Technology, Inc.

GENERAL DISCLAIMER

Integrated Device Technology, Inc. reserves the right to make changes to its products or specifications at any time, without notice, in order to improve design or performance and to supply the best possible product. IDT does not assume any responsibility for use of any circuitry described other than the circuitry embodied in an IDT product. The Company makes no representations that circuitry described herein is free from patent infringement or other rights of third parties which may result from its use. No license is granted by implication or otherwise under any patent, patent rights or other rights, of Integrated Device Technology, Inc.

CODE DISCLAIMER

Code examples provided by IDT are for illustrative purposes only and should not be relied upon for developing applications. Any use of the code examples below is completely at your own risk. IDT MAKES NO REPRESENTATIONS OR WARRANTIES OF ANY KIND CONCERNING THE NONINFRINGEMENT, QUALITY, SAFETY OR SUITABILITY OF THE CODE, EITHER EXPRESS OR IMPLIED, INCLUDING WITHOUT LIMITATION ANY IMPLIED WARRANTIES OF MERCHANTABILITY, FITNESS FOR A PARTICULAR PURPOSE, OR NON-INFRINGEMENT. FURTHER, IDT MAKES NO REPRESENTATIONS OR WARRANTIES AS TO THE TRUTH, ACCURACY OR COMPLETENESS OF ANY STATEMENTS, INFORMATION OR MATERIALS CONCERNING CODE EXAMPLES CONTAINED IN ANY IDT PUBLICATION OR PUBLIC DISCLOSURE OR THAT IS CONTAINED ON ANY IDT INTERNET SITE. IN NO EVENT WILL IDT BE LIABLE FOR ANY DIRECT, CONSEQUENTIAL, INCIDENTAL, INDIRECT, PUNITIVE OR SPECIAL DAMAGES, HOWEVER THEY MAY ARISE, AND EVEN IF IDT HAS BEEN PREVIOUSLY ADVISED ABOUT THE POSSIBILITY OF SUCH DAMAGES. The code examples also may be subject to United States export control laws and may be subject to the export or import laws of other countries and it is your responsibility to comply with any applicable laws or regulations.

LIFE SUPPORT POLICY

Integrated Device Technology's products are not authorized for use as critical components in life support devices or systems unless a specific written agreement pertaining to such intended use is executed between the manufacturer and an officer of IDT.

1. Life support devices or systems are devices or systems which (a) are intended for surgical implant into the body or (b) support or sustain life and whose failure to perform, when properly used in accordance with instructions for use provided in the labeling, can be reasonably expected to result in a significant injury to the user.
2. A critical component is any components of a life support device or system whose failure to perform can be reasonably expected to cause the failure of the life support device or system, or to affect its safety or effectiveness.

IDT, the IDT logo, and Integrated Device Technology are trademarks or registered trademarks of Integrated Device Technology, Inc.



Notes

Introduction

This user manual includes hardware and software information on the 89HPES3T3, a member of IDT's PRECISE™ family of PCI Express® switching solutions offering the next-generation I/O interconnect standard.

Finding Additional Information

Information not included in this manual such as mechanicals, package pin-outs, and electrical characteristics can be found in the data sheet for this device, which is available from the IDT website (www.idt.com) as well as through your local IDT sales representative.

Content Summary

Chapter 1, "PES3T3 Device Overview," provides a complete introduction to the performance capabilities of the 89HPES3T3. Included in this chapter is a summary of features for the device as well as a system block diagram and pin description.

Chapter 2, "Clocking, Reset, and Initialization," provides a description of the two differential reference clock inputs that are used internally to generate all of the clocks required by the internal switch logic and the SerDes.

Chapter 3, "Theory of Operation," describes the operation of the link feature including polarity inversion, link width negotiation, and lane reversal.

Chapter 4, "Link Operation," describes the operation of the link feature including polarity inversion, link width negotiation, and lane reversal.

Chapter 5, "General Purpose I/O," describes how the 5 General Purpose I/O (GPIO) pins may be individually configured as general purpose inputs, general purpose outputs, or alternate functions.

Chapter 6, "SMBus Interfaces," describes the operation of the SMBus master interface on the PES3T3.

Chapter 7, "Power Management," describes the power management capability structure located in the configuration space of each PCI-PCI bridge in the PES3T3.

Chapter 8, "Hot-Plug and Hot-Swap," describes the behavior of the hot-plug and hot-swap features in the PES3T3.

Chapter 9, "Configuration Registers," discusses the base addresses, PCI configuration space, and registers associated with the PES3T3.

Chapter 10, "JTAG Boundary Scan," discusses an enhanced JTAG interface, including a system logic TAP controller, signal definitions, a test data register, an instruction register, and usage considerations.

Signal Nomenclature

To avoid confusion when dealing with a mixture of "active-low" and "active-high" signals, the terms assertion and negation are used. The term assert or assertion is used to indicate that a signal is active or true, independent of whether that level is represented by a high or low voltage. The term negate or negation is used to indicate that a signal is inactive or false.

To define the active polarity of a signal, a suffix will be used. Signals ending with an 'N' should be interpreted as being active, or asserted, when at a logic zero (low) level. All other signals (including clocks, buses and select lines) will be interpreted as being active, or asserted when at a logic one (high) level.

Notes

To define buses, the most significant bit (MSB) will be on the left and least significant bit (LSB) will be on the right. No leading zeros will be included.

Throughout this manual, when describing signal transitions, the following terminology is used. Rising edge indicates a low-to-high (0 to 1) transition. Falling edge indicates a high-to-low (1 to 0) transition. These terms are illustrated in Figure 1.

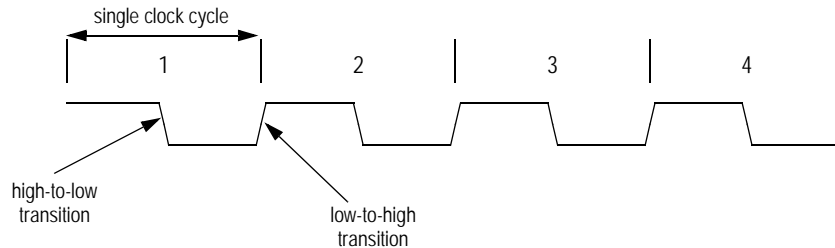

Figure 1 Signal Transitions

Numeric Representations

To represent numerical values, either decimal, binary, or hexadecimal formats will be used. The binary format is as follows: 0bDDD, where "D" represents either 0 or 1; the hexadecimal format is as follows: 0xDD, where "D" represents the hexadecimal digit(s); otherwise, it is decimal.

The compressed notation ABC[x|y|z]D refers to ABCxD, ABCyD, and ABCzD.

The compressed notation ABC[x:y]D refers to ABCxD, ABC(x+1)D, ABC(x+2)D,... ABCyD if $x < y$ or to ABCxD, ABC(x-1)D, ABC(x-2)D,... ABCyD if $x > y$.

Data Units

The following data unit terminology is used in this document.

Term	Words	Bytes	Bits
Byte	1/2	1	8
Word	1	2	16
Doubleword (Dword)	2	4	32
Quadword (Qword)	4	8	64

Table 1 Data Unit Terminology

In quadwords, bit 63 is always the most significant bit and bit 0 is the least significant bit. In doublewords, bit 31 is always the most significant bit and bit 0 is the least significant bit. In words, bit 15 is always the most significant bit and bit 0 is the least significant bit. In bytes, bit 7 is always the most significant bit and bit 0 is the least significant bit.

The ordering of bytes within words is referred to as either "big endian" or "little endian." Big endian systems label byte zero as the most significant (leftmost) byte of a word. Little endian systems label byte zero as the least significant (rightmost) byte of a word.

Notes

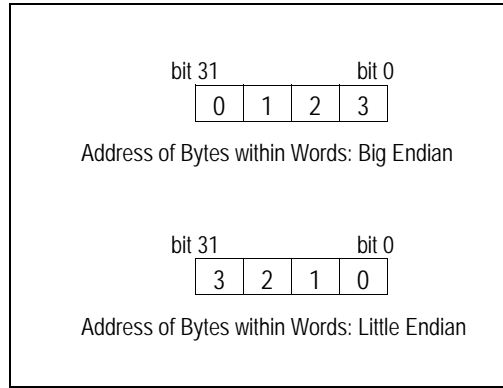

Table 2 Example of Byte Ordering for “Big Endian” or “Little Endian” System Definition

Register Terminology

Note: Software in the context of this register terminology refers to modifications made by PCIe root configuration writes to registers made through the serial EEPROM register initialization.

Type	Abbreviation	Description
Hardware Initialized	HWINIT	Register bits are initialized by firmware or hardware mechanisms such as pin strapping or serial EEPROM. (System firmware hardware initialization is only allowed for system integrated devices.) Bits are read-only after initialization and can only be reset (for write-once by firmware) with reset.
Read Only and Clear	RC	Software can read the register/bits with this attribute. Reading the value will automatically cause the register/bit to be reset to zero. Writing to a RC location has no effect.
Read Clear and Write	RCW	Software can read the register/bits with this attribute. Reading the value will automatically cause the register/bits to be reset to zero. Writes cause the register/bits to be modified.
Reserved	Reserved	The value read from a reserved register/bit is undefined. Thus, software must deal correctly with fields that are reserved. On reads, software must use appropriate masks to extract the defined bits and not rely on reserved bits being any particular value. On writes, software must ensure that the values of reserved bit positions are preserved. That is, the values of reserved bit positions must first be read, merged with the new values for other bit positions and then written back.
Read Only	RO	Software can only read registers/bits with this attribute. Contents are hardwired to a constant value or are status bits that may be set and cleared by hardware. Writing to a RO location has no effect.
Read and Write	RW	Software can both read and write bits with this attribute.
Read and Write Clear	RW1C	Software can read and write to registers/bits with this attribute. However, writing a value of zero to a bit with this attribute has no effect. A RW1C bit can only be set to a value of 1 by a hardware event. To clear a RW1C bit (i.e., change its value to zero) a value of one must be written to the location. An RW1C bit is never cleared by hardware.

Table 3 Register Terminology (Sheet 1 of 2)

Notes

Type	Abbreviation	Description
Read and Write when Unlocked	RWL	Software can read the register/bits with this attribute. Writing to register/bits with this attribute will only cause the value to be modified if the REGUNLOCK bit in the SWCNTL register is set. When the REGUNLOCK bit is cleared, writes are ignored and the register/bits are effectively read-only. These registers are Sticky as they are preserved across a hot reset. These bits are not preserved during fundamental reset.
Read Only Sticky	ROS	Registers are read-only and cannot be altered by software. Registers are not initialized or modified by hot reset. When device consumes AUX power, some of these bits maintain their value across fundamental reset and are marked FRSticky.
Read and Write Sticky	RWS	Registers are read-write and may be either set or cleared by software to the desired state. Bits are not initialized or modified by hot reset. When device consumes AUX power, some of these bits maintain their value across fundamental reset and are marked FRSticky.
Read Write-1-to-Clear Sticky	RWICS	Registers indicate status when read, a set bit indicating a status event may be cleared by writing a 1. Writing a 0 to RW1CS bits has no effect. Bits are not initialized or modified by hot reset. When device consumes AUX power, some of these bits maintain their value across fundamental reset and are marked FRSticky.
Write Transient	WT	The zero is always read from a bit/field of this type. Writing of a one is used to qualify the writing of other bits/fields in the same register.
Zero	Zero	A zero register or bit must be written with a value of zero and returns a value of zero when read.

Table 3 Register Terminology (Sheet 2 of 2)

Use of Hypertext

In Chapter 9, Tables 9.2 and 9.3 contain register names and page numbers highlighted in blue under the Register Definition column. In pdf files, users can jump from this source table directly to the registers by clicking on the register name in the source table. Each register name in the table is linked directly to the appropriate register in the register section of the chapter. To return to the source table after having jumped to the register section, click on the same register name (in blue) in the register section.

Reference Documents

- PCI Express Base Specification, Revision 1.1, PCI Special Interest Group.
- PCI Power Management Interface Specification, Revision 1.2, PCI Special Interest Group.
- PCI to PCI Bridge Architecture Specification, Revision 1.2, PCI Special Interest Group.

Revision History

- June 20, 2007:** Initial Publication.
- July 11, 2007:** Corrected AERUCS to AERUES in AERCTL register, Chapter 8.

Notes

July 16, 2007: Made numerous minor edits throughout manual. Removed all references to slave SMBus.

August 16, 2007: Removed incorrect references to multiple PEREFCLKN/P pins.

June 6, 2008: In Chapter 1, updated the Features section to include 10x10mm 132-pin package option

September 24, 2009: In Chapter 3, change made to L2 description in Link States section. In Chapter 5, SMBus, added Note in I/O Expander section re setting of GPIOFUNC[4:2] bits. Made numerous changes in Chapter 6, Power. In Chapter 8, Registers, modified description of the LDIS bit in the PCI Express Link Control register and changed bit field for CTLPTOC in the Switch Time-Out Count register to [24:16].

November 10, 2009: Added a new Chapter 3 called Theory of Operations.

February 1, 2011: ZB silicon added to Table 1.9, Revision ID.

Notes



Notes

About this Manual

Introduction 1
 Content Summary 1
 Signal Nomenclature 1
 Numeric Representations 2
 Data Units 2
 Register Terminology 3
 Use of Hypertext 4
 Reference Documents 4
 Revision History 4

PES3T3 Device Overview

Device Overview 1-1
 Features 1-1
 System Diagrams 1-2
 Logic Diagram 1-3
 SSID/SSVID 1-3
 Device Serial Number Enhanced Capability 1-3
 Pin Description 1-3
 Pin Characteristics 1-7
 System Identification 1-8
 Vendor ID 1-8
 Device ID 1-8
 Revision ID 1-8
 JTAG ID 1-8
 Port Configuration 1-8

Clocking, Reset, and Initialization

Introduction 2-1
 Initialization 2-3
 Reset 2-4
 Fundamental Reset 2-5
 Hot Reset 2-6
 Upstream Secondary Bus Reset 2-7
 Downstream Secondary Bus Reset 2-8
 Downstream Port Reset Outputs 2-8
 Power Enable Controlled Reset Output 2-8
 Power Good Controlled Reset Output 2-9
 Hot Reset Controlled Reset Output 2-10

Theory of Operation

Port Interrupts 3-1
 Legacy Interrupt Emulation 3-1

Link Operation

Introduction 4-1

Notes

Polarity Inversion 4-1
 Link Width Negotiation 4-1
 Link Retraining 4-1
 Link Down 4-1
 Slot Power Limit Support 4-2
 Upstream Port 4-2
 Downstream Port 4-2
 Link States 4-2
 Active State Power Management 4-3
 Link Status 4-4

General Purpose Inputs/Outputs

Introduction 5-1
 GPIO Configuration 5-1
 GPIO Pin Configured as an Input 5-1
 GPIO Pin Configured as an Output 5-2
 GPIO Pin Configured as an Alternate Function 5-2

SMBus Interfaces

Introduction 6-1
 Master SMBus Interface 6-1
 Initialization 6-1
 Serial EEPROM 6-1
 I/O Expanders 6-5

Power Management

Introduction 7-1
 PME Messages 7-2
 Power Express Power Management Fence Protocol 7-3
 Power Budgeting Capability 7-3
 Wakeup Protocol 7-4
 WAKEN Signal as an Input 7-5
 WAKEN Signal as an Output 7-5
 WAKEN and Beacon Disabled 7-5
 Auxiliary Power Implementation 7-5
 Switch System States 7-5
 Auxiliary Power Control 7-6
 PES3T3 Auxiliary Power Usage 7-8

Hot-Plug and Hot-Swap

Introduction 8-1
 Hot-Plug I/O Expander 8-4
 Hot-Plug Interrupts and Wake-up 8-4
 Legacy System Hot-Plug Support 8-4
 Hot-Swap 8-6

Configuration Registers

Configuration Space Organization 9-1
 Upstream Port (Port 0) 9-3
 Downstream Ports (Ports 2 and 3) 9-7
 Register Definitions 9-11
 Type 1 Configuration Header Registers 9-11

Notes

PCI Express Capability Structure 9-21
 Power Management Capability Structure 9-32
 Message Signaled Interrupt Capability Structure 9-34
 Subsystem ID and Subsystem Vendor ID 9-35
 Extended Configuration Space Access Registers 9-36
 Advanced Error Reporting (AER) Enhanced Capability 9-37
 Device Serial Number Enhanced Capability 9-43
 PCI Express Virtual Channel Capability 9-43
 Power Budgeting Enhanced Capability 9-49
 Switch Control and Status Registers 9-51
 Internal Switch Error Control and Status Registers 9-60
 Wakeup Protocol Registers 9-63

JTAG Boundary Scan

Introduction 10-1
 Test Access Point 10-1
 Signal Definitions 10-1
 Boundary Scan Chain 10-3
 Test Data Register (DR) 10-3
 Boundary Scan Registers 10-4
 Instruction Register (IR) 10-5
 EXTEST 10-6
 SAMPLE/PRELOAD 10-6
 BYPASS 10-6
 CLAMP 10-7
 IDCODE 10-7
 VALIDATE 10-7
 RESERVED 10-7
 Usage Considerations 10-8

Notes



Notes

Table 1.1	PCI Express Interface Pins.....	1-4
Table 1.2	SMBus Interface Pins.....	1-4
Table 1.3	General Purpose I/O Pins.....	1-4
Table 1.4	System Pins.....	1-5
Table 1.6	Power and Ground Pins.....	1-6
Table 1.5	Test Pins.....	1-6
Table 1.7	Pin Characteristics.....	1-7
Table 1.8	PES3T3 Device ID.....	1-8
Table 1.9	PES3T3 Revision ID.....	1-8
Table 2.1	Boot Configuration Vector Signals.....	2-4
Table 3.1	Downstream Port Interrupts.....	3-1
Table 3.2	PES3T3 Downstream to Upstream Port Interrupt Routing.....	3-2
Table 5.1	General Purpose I/O Pin Alternate Function.....	5-1
Table 5.2	GPIO Pin Configuration.....	5-1
Table 6.1	PES3T3 Compatible Serial EEPROMs.....	6-1
Table 6.2	Serial EEPROM Initialization Errors.....	6-4
Table 6.3	I/O Expander Function Allocation.....	6-5
Table 6.4	I/O Expander Default Output Signal Value.....	6-6
Table 6.5	I/O Expander 0 Signals.....	6-8
Table 6.6	I/O Expander 1 Signals.....	6-9
Table 6.7	I/O Expander 2 Signals.....	6-10
Table 6.8	I/O Expander 4 Signals.....	6-10
Table 7.1	PES3T3 Power Management State Transition Diagram.....	7-2
Table 7.2	Auxiliary Power Enabled (Beacon OFF).....	7-9
Table 7.3	Auxiliary Power Enabled (SerDes OFF, only WAKEN Enabled).....	7-9
Table 9.1	Base Addresses for Port Configuration Space Registers.....	9-1
Table 9.2	Upstream Port 0 Configuration Space Registers.....	9-3
Table 9.3	Downstream Ports 2 through 5 Configuration Space Registers.....	9-7
Table 10.1	JTAG Pin Descriptions.....	10-2
Table 10.2	Boundary Scan Chain.....	10-3
Table 10.3	Instructions Supported by PES3T3's JTAG Boundary Scan.....	10-6
Table 10.4	System Controller Device Identification Register.....	10-7

Notes



List of Figures

Notes

Figure 1.1	PES3T3 Architectural Block Diagram	1-2
Figure 1.2	PES3T3 Logic Diagram	1-3
Figure 1.3	PES3T3 Port Configuration	1-9
Figure 2.1	Common Clock on Upstream and Downstream (option to enable or disable Spread Spectrum Clock)	2-1
Figure 2.2	Non-Common Clock on Upstream; Common Clock on Downstream (must disable Spread Spectrum Clock)	2-2
Figure 2.3	Common Clock on Upstream; Non-Common Clock on Downstream (must disable Spread Spectrum Clock)	2-2
Figure 2.4	Non-Common Clock on Upstream and Downstream (must disable Spread Spectrum Clock)	2-3
Figure 2.5	Fundamental Reset with Serial EEPROM initialization	2-6
Figure 2.6	Power Enable Controlled Reset Output Mode Operation	2-9
Figure 2.7	Power Good Controlled Reset Output Mode Operation	2-9
Figure 4.1	PES3T3 ASPM Link State Transitions	4-3
Figure 6.1	Single Double Word Initialization Sequence Format	6-2
Figure 6.2	Sequential Double Word Initialization Sequence Format	6-3
Figure 6.3	Configuration Done Sequence Format	6-3
Figure 7.1	PES3T3 Power Management State Transition Diagram	7-1
Figure 7.2	PES3T3 System States	7-5
Figure 7.3	L2 Mode Enable/Disable and FRSticky Bit Initialization	7-7
Figure 7.4	Vaux Usage Model	7-8
Figure 7.5	Conceptual Diagram of the PES3T3 Auxiliary Power Connection	7-10
Figure 8.1	Hot-Plug on Switch Downstream Slots Application	8-1
Figure 8.2	Hot-Plug with Switch on Add-In Card Application	8-2
Figure 8.3	Hot-Plug with Carrier Card Application	8-2
Figure 8.4	PES3T3 Hot-Plug Event Signalling	8-5
Figure 9.1	Port Configuration Space Organization	9-2
Figure 10.1	Diagram of the JTAG Logic	10-1
Figure 10.2	State Diagram of PES3T3's TAP Controller	10-2
Figure 10.3	Diagram of Observe-only Input Cell	10-4
Figure 10.4	Diagram of Output Cell	10-4
Figure 10.5	Diagram of Bidirectional Cell	10-5
Figure 10.6	Device ID Register Format	10-7

Notes



Notes

AERCAP - AER Capabilities (0x100) 9-37

AERCEM - AER Correctable Error Mask (0x114) 9-41

AERCES - AER Correctable Error Status (0x110) 9-40

AERCTL - AER Control (0x118) 9-41

AERHL1DW - AER Header Log 1st Doubleword (0x11C) 9-42

AERHL2DW - AER Header Log 2nd Doubleword (0x120) 9-42

AERHL3DW - AER Header Log 3rd Doubleword (0x124) 9-42

AERHL4DW - AER Header Log 4th Doubleword (0x128) 9-42

AERUEM - AER Uncorrectable Error Mask (0x108) 9-38

AERUES - AER Uncorrectable Error Status (0x104) 9-37

AERUESV - AER Uncorrectable Error Severity (0x10C) 9-39

BAR0 - Base Address Register 0 (0x010) 9-14

BAR1 - Base Address Register 1 (0x014) 9-14

BCTL - Bridge Control Register (0x03E) 9-19

BIST - Built-in Self Test Register (0x00F) 9-14

CAPPTR - Capabilities Pointer Register (0x034) 9-19

CCODE - Class Code Register (0x009) 9-13

CLS - Cache Line Size Register (0x00C) 9-14

DID - Device Identification Register (0x002) 9-11

ECFGADDR - Extended Configuration Space Access Address (0x0F8) 9-36

ECFGDATA - Extended Configuration Space Access Data (0x0FC) 9-36

EEPROMINTF - Serial EEPROM Interface (0x34C) 9-57

EROMBASE - Expansion ROM Base Address Register (0x038) 9-19

GPECTL - General Purpose Event Control (0x35C) 9-59

GPESTS - General Purpose Event Status (0x360) 9-59

GPIOCFG - General Purpose I/O Configuration (0x33C) 9-55

GPIOD - General Purpose I/O Data (0x340) 9-55

GPIOFUNC - General Purpose I/O Control Function (0x338) 9-55

GPR - General Purpose Register (0x334) 9-54

HDR - Header Type Register (0x00E) 9-14

HPCFGCTL - Hot-Plug Configuration Control (0x330) 9-53

INTRLINE - Interrupt Line Register (0x03C) 9-19

INTRPIN - Interrupt PIN Register (0x03D) 9-19

IOBASE - I/O Base Register (0x01C) 9-15

IOBASEU - I/O Base Upper Register (0x030) 9-18

IOEXPADDR0 - SMBus I/O Expander Address 0 (0x354) 9-58

IOEXPADDR1 - SMBus I/O Expander Address 1 (0x358) 9-59

IOEXPINTF - I/O Expander Interface (0x350) 9-57

IOLIMIT - I/O Limit Register (0x01D) 9-16

IOLIMITU - I/O Limit Upper Register (0x032) 9-18

MBASE - Memory Base Register (0x020) 9-16

MLIMIT - Memory Limit Register (0x022) 9-17

MSIADDR - Message Signaled Interrupt Address (0x0D4) 9-34

MSICAP - Message Signaled Interrupt Capability and Control (0x0D0) 9-34

MSIMDATA - Message Signaled Interrupt Message Data (0x0DC) 9-35

MSIUADDR - Message Signaled Interrupt Upper Address (0x0D8) 9-35

PBUSN - Primary Bus Number Register (0x018) 9-15

PCICMD - PCI Command Register (0x004) 9-11

PCIECAP - PCI Express Capability (0x040) 9-21

Notes

PCIEDCAP - PCI Express Device Capabilities (0x044)	9-21
PCIEDCAP2 - PCI Express Device Capabilities 2 (0x064)	9-31
PCIEDCTL - PCI Express Device Control (0x048)	9-22
PCIEDCTL2 - PCI Express Device Control 2 (0x068)	9-31
PCIEDSTS - PCI Express Device Status (0x04A)	9-23
PCIEDSTS2 - PCI Express Device Status 2 (0x06A)	9-31
PCIELCAP - PCI Express Link Capabilities (0x04C)	9-24
PCIELCAP2 - PCI Express Link Capabilities 2 (0x06C)	9-31
PCIELCTL - PCI Express Link Control (0x050)	9-25
PCIELCTL2 - PCI Express Link Control 2 (0x070)	9-31
PCIELSTS - PCI Express Link Status (0x052)	9-26
PCIELSTS2 - PCI Express Link Status 2 (0x072)	9-32
PCIESCAP - PCI Express Slot Capabilities (0x054)	9-27
PCIESCAP2 - PCI Express Slot Capabilities 2 (0x074)	9-32
PCIESCTL - PCI Express Slot Control (0x058)	9-28
PCIESCTL2 - PCI Express Slot Control 2 (0x078)	9-32
PCIESSTS - PCI Express Slot Status (0x05A)	9-30
PCIESSTS2 - PCI Express Slot Status 2 (0x07A)	9-32
PCIEVCECAP - PCI Express VC Enhanced Capability Header (0x200)	9-43
PCISTS - PCI Status Register (0x006)	9-12
PLTIMER - Primary Latency Timer (0x00D)	9-14
PMBASE - Prefetchable Memory Base Register (0x024)	9-17
PMBASEU - Prefetchable Memory Base Upper Register (0x028)	9-18
PMCAP - PCI Power Management Capabilities (0x0C0)	9-32
PMCSR - PCI Power Management Control and Status (0x0C4)	9-33
PMLIMIT - Prefetchable Memory Limit Register (0x026)	9-17
PMLIMITU - Prefetchable Memory Limit Upper Register (0x02C)	9-18
PVCCAP1 - Port VC Capability 1 (0x204)	9-43
PVCCAP2 - Port VC Capability 2 (0x208)	9-44
PVCCCTL - Port VC Control (0x20C)	9-45
PVCSTS - Port VC Status (0x20E)	9-45
PWRBCAP - Power Budgeting Capabilities (0x280)	9-49
PWRBD - Power Budgeting Data (0x288)	9-50
PWRBDSEL - Power Budgeting Data Select (0x284)	9-50
PWRBDV[9:0] - Power Budgeting Data Value [9:0] (0x300)	9-50
PWRBPBC - Power Budgeting Power Budget Capability (0x28C)	9-50
RID - Revision Identification Register (0x008)	9-13
SBUSN - Secondary Bus Number Register (0x019)	9-15
SECSTS - Secondary Status Register (0x01E)	9-16
SLTIMER - Secondary Latency Timer Register (0x01B)	9-15
SMBUSCTL - SMBus Control (0x348)	9-56
SMBUSSTS - SMBus Status (0x344)	9-55
SNUMCAP - Serial Number Capabilities (0x180)	9-43
SNUMLDW - Serial Number Lower Doubleword (0x184)	9-43
SNUMUDW - Serial Number Upper Doubleword (0x188)	9-43
SSIDSSVID - Subsystem ID and Subsystem Vendor ID (0x0F4)	9-36
SSIDSSVIDCAP - Subsystem ID and Subsystem Vendor ID Capability (0x0F0)	9-35
SUBUSN - Subordinate Bus Number Register (0x01A)	9-15
SWCTL - Switch Control (0x32C)	9-51
SWERRCNT - Switch Internal Error Count (0x4E0)	9-61
SWERRCTL - Switch Internal Error Reporting Control (0x4DC)	9-61
SWERRSTS - Switch Internal Error Status (0x4D8)	9-60
SWPECTL - Switch Parity Error Control (0x4D4)	9-60
SWSTS - Switch Status (0x328)	9-51
SWTOCNT - Switch Time-Out Count (0x4EC)	9-62

Notes

SWTOCTL - Switch Time-Out Control (0x4E4).....	9-61
SWTORCTL - Switch Time-Out Reporting Control (0x4E8).....	9-62
VCR0CAP- VC Resource 0 Capability (0x210).....	9-45
VCR0CTL- VC Resource 0 Control (0x214).....	9-46
VCR0STS - VC Resource 0 Status (0x218).....	9-47
VCR0TBL0 - VC Resource 0 Arbitration Table Entry 0 (0x220).....	9-47
VCR0TBL1 - VC Resource 0 Arbitration Table Entry 1 (0x224).....	9-48
VCR0TBL2 - VC Resource 0 Arbitration Table Entry 2 (0x228).....	9-48
VCR0TBL3 - VC Resource 0 Arbitration Table Entry 3 (0x22C).....	9-49
VID - Vendor Identification Register (0x000).....	9-11
WAKEUPCNTL - Wakeup Protocol Control Register (0x5CC).....	9-63

Notes



PES3T3 Device Overview

Notes

Device Overview

The 89HPES3T3 is a member of IDT's PRECISE™ family of PCI Express switching solutions. The PES3T3 is a 3-lane, 3-port peripheral chip that performs PCI Express Base switching. It provides connectivity and switching functions between a PCI Express upstream port and up to four downstream ports and supports switching between downstream ports.

Features

◆ High Performance PCI Express Switch

- Three 2.5Gbps PCI Express lanes
- Three switch ports
- x1 Upstream port
- Two x1 Downstream ports
- Low latency cut-through switch architecture
- Support for Max payload sizes up to 256 bytes
- One virtual channel
- Eight traffic classes
- PCI Express Base Specification Revision 1.1 compliant

◆ Flexible Architecture with Numerous Configuration Options

- Automatic lane reversal on all ports
- Automatic polarity inversion on all lanes
- Ability to load device configuration from serial EEPROM

◆ Legacy Support

- PCI compatible INTx emulation
- Bus locking

◆ Highly Integrated Solution

- Requires no external components
- Incorporates on-chip internal memory for packet buffering and queueing
- Integrates three 2.5 Gbps embedded SerDes with 8B/10B encoder/decoder (no separate transceivers needed)

◆ Reliability, Availability, and Serviceability (RAS) Features

- Internal end-to-end parity protection on all TLPs ensures data integrity even in systems that do not implement end-to-end CRC (ECRC)
- Supports ECRC and Advanced Error Reporting
- Supports PCI Express Native Hot-Plug, Hot-Swap capable I/O
- Compatible with Hot-Plug I/O expanders used on PC motherboards

◆ Power Management

- Utilizes advanced low-power design techniques to achieve low typical power consumption
- Supports PCI Power Management Interface specification (PCI-PM 1.2)
- Unused SerDes are disabled.
- Supports Advanced Configuration and Power Interface Specification, Revision 2.0 (ACPI) supporting active link state

◆ Testability and Debug Features

- Built in Pseudo-Random Bit Stream (PRBS) generator
- Numerous SerDes test modes
- Ability to bypass link training and force any link into any mode
- Provides statistics and performance counters

Notes

- ◆ Five General Purpose Input/Output Pins
 - Each pin may be individually configured as an input or output
 - Each pin may be individually configured as an interrupt input
 - Four pins have selectable alternate functions
- ◆ Option A Package: 13mm x 13mm 144-ball BGA with 1mm ball spacing
- ◆ Option B Package: 10mm x 10mm 132-ball QFN with 1mm ball spacing

System Diagrams

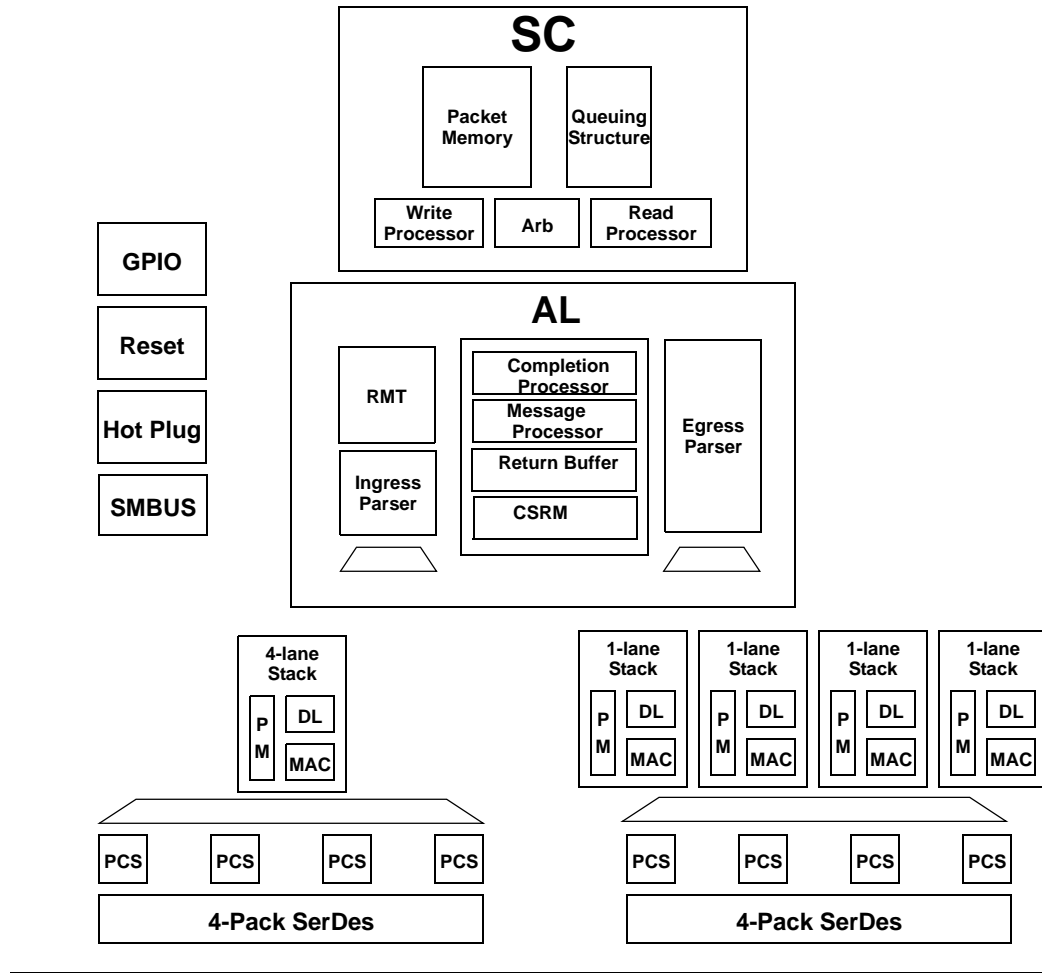

Figure 1.1 PES3T3 Architectural Block Diagram

Logic Diagram

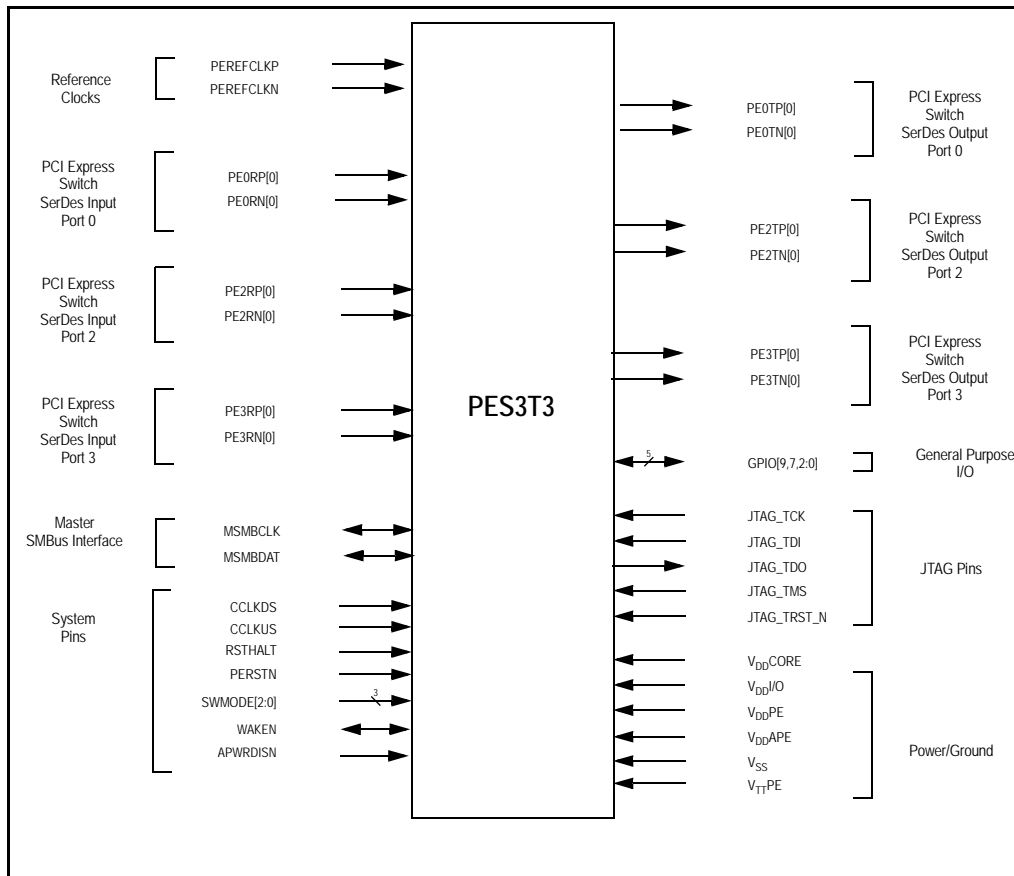

Figure 1.2 PES3T3 Logic Diagram

SSID/SSVID

The PES3T3 contains the mechanisms necessary to implement the PCI-to-PCI bridge Subsystem ID and Subsystem Vendor ID capability structure. However, in the default configuration the Subsystem ID and Subsystem Vendor ID capability structure is not enabled. To enable this capability, the SSID and SSVID fields in the Subsystem ID and Subsystem Vendor ID (SSIDSSVID) register must be initialized with the appropriate ID values. The Next Pointer (NXTPTR) field in one of the other enhanced capabilities should be initialized to point to this capability. Finally, the Next Pointer (NXTPTR) of this capability should be adjusted to point to the next capability if necessary.

Device Serial Number Enhanced Capability

The PES3T3 contains the mechanisms necessary to implement the PCI express device serial number enhanced capability. However, in the default configuration this capability structure is not enabled. To enable the device serial number enhanced capability, the Serial Number Lower Doubleword (SNUMLDW) and the Serial Number Upper Doubleword (SNUMUDW) registers should be initialized. The Next Pointer (NXTPTR) field in one of the other enhanced capabilities should be initialized to point to this capability. Finally, the Next Pointer (NXTPTR) of this capability should be adjusted to point to the next capability if necessary.

Pin Description

The following tables lists the functions of the pins provided on the PES3T3. Some of the functions listed may be multiplexed onto the same pin. The active polarity of a signal is defined using a suffix. Signals ending with an "N" are defined as being active, or asserted, when at a logic zero (low) level. All other signals (including clocks, buses, and select lines) will be interpreted as being active, or asserted, when at a logic one (high) level.

Notes

Signal	Type	Name/Description
PE0RP[0] PE0RN[0]	I	PCI Express Port 0 Serial Data Receive. Differential PCI Express receive pair for port 0.
PE0TP[0] PE0TN[0]	O	PCI Express Port 0 Serial Data Transmit. Differential PCI Express transmit pair for port 0.
PE2RP[0] PE2RN[0]	I	PCI Express Port 2 Serial Data Receive. Differential PCI Express receive pair for port 2.
PE2TP[0] PE2TN[0]	O	PCI Express Port 2 Serial Data Transmit. Differential PCI Express transmit pair for port 2.
PE3RP[0] PE3RN[0]	I	PCI Express Port 3 Serial Data Receive. Differential PCI Express receive pair for port 3.
PE3TP[0] PE3TN[0]	O	PCI Express Port 3 Serial Data Transmit. Differential PCI Express transmit pair for port 3.
PEREFCLKP PEREFCLKN	I	PCI Express Reference Clock. Differential reference clock pair input. This clock is used as the reference clock by on-chip PLLs to generate the clocks required for the system logic and on-chip SerDes. The frequency of the differential reference clock is 100 MHz.

Table 1.1 PCI Express Interface Pins

Signal	Type	Name/Description
MSMBCLK	I/O	Master SMBus Clock. This bidirectional signal is used to synchronize transfers on the master SMBus.
MSMBDAT	I/O	Master SMBus Data. This bidirectional signal is used for data on the master SMBus.

Table 1.2 SMBus Interface Pins

Signal	Type	Name/Description
GPIO[0]	I/O	General Purpose I/O. This pin can be configured as a general purpose I/O pin. Alternate function pin name: P2RSTN Alternate function pin type: Output Alternate function: Reset output for downstream port 2
GPIO[1]	I/O	General Purpose I/O. This pin can be configured as a general purpose I/O pin.

Table 1.3 General Purpose I/O Pins (Part 1 of 2)

Notes

Signal	Type	Name/Description
GPIO[2]	I/O	General Purpose I/O. This pin can be configured as a general purpose I/O pin. Alternate function pin name: IOEXPINTNO Alternate function pin type: Input Alternate function: I/O Expander interrupt 0 input
GPIO[7]	I/O	General Purpose I/O. This pin can be configured as a general purpose I/O pin. Alternate function pin name: GPEN Alternate function pin type: Output Alternate function: General Purpose Event (GPE) output
GPIO[9]	I/O	General Purpose I/O. This pin can be configured as a general purpose I/O pin. Alternate function pin name: P3RSTN Alternate function pin type: Output Alternate function: Reset output for downstream port 3

Table 1.3 General Purpose I/O Pins (Part 2 of 2)

Signal	Type	Name/Description
APWRDISN	I	Auxiliary Power Disable Input. When this pin is active, it disables the device from using auxiliary power supply.
CCLKDS	I	Common Clock Downstream. The assertion of this pin indicates that all downstream ports are using the same clock source as that provided to downstream devices. This bit is used as the initial value of the Slot Clock Configuration bit in all of the Link Status Registers for downstream ports. The value may be override by modifying the SCLK bit in the downstream port's PCIELSTS register.
CCLKUS	I	Common Clock Upstream. The assertion of this pin indicates that the upstream port is using the same clock source as the upstream device. This bit is used as the initial value of the Slot Clock Configuration bit in the Link Status Register for the upstream port. The value may be overridden by modifying the SCLK bit in the PA_PCIEIPTS register.
PERSTN	I	Fundamental Reset. Assertion of this signal resets all logic inside the PES3T3 and initiates a PCI Express fundamental reset.
RSTHALT	I	Reset Halt. When this signal is asserted during a PCI Express fundamental reset, the PES3T3 executes the reset procedure and remains in a reset state with the Master SMBus active. This allows software to read and write registers internal to the device before normal device operation begins. The device exits the reset state when the RSTHALT bit is cleared in the PA_SWCTL register by the SMBus master.
SWMODE[2:0]	I	Switch Mode. These configuration pins determine the PES3T3 switch operating mode. 0x0 - Normal switch mode 0x1 - Normal switch mode with Serial EEPROM initialization 0x2 - through 0xF Reserved
WAKEN	I/O	Wake Input/Output. The WAKEN signal is an input or output. The WAKEN signal input/output selection can be made through WAKEDIR bit setting in the WAKEUPCNTL register.

Table 1.4 System Pins

Notes

Signal	Type	Name/Description
JTAG_TCK	I	JTAG Clock. This is an input test clock used to clock the shifting of data into or out of the boundary scan logic or JTAG Controller. JTAG_TCK is independent of the system clock with a nominal 50% duty cycle.
JTAG_TDI	I	JTAG Data Input. This is the serial data input to the boundary scan logic or JTAG Controller.
JTAG_TDO	O	JTAG Data Output. This is the serial data shifted out from the boundary scan logic or JTAG Controller. When no data is being shifted out, this signal is tri-stated.
JTAG_TMS	I	JTAG Mode. The value on this signal controls the test mode select of the boundary scan logic or JTAG Controller.
JTAG_TRST_N	I	JTAG Reset. This active low signal asynchronously resets the boundary scan logic and JTAG TAP Controller. An external pull-up on the board is recommended to meet the JTAG specification in cases where the tester can access this signal. However, for systems running in functional mode, one of the following should occur: 1) actively drive this signal low with control logic 2) statically drive this signal low with an external pull-down on the board

Table 1.5 Test Pins

Signal	Type	Name/Description
V _{DD} CORE	I	Core VDD. Power supply for core logic.
V _{DD} I/O	I	I/O VDD. LVTTTL I/O buffer power supply.
V _{DD} PE	I	PCI Express Digital Power. PCI Express digital power used by the digital power of the SerDes.
V _{DD} APE	I	PCI Express Analog Power. PCI Express analog power used by the PLL and bias generator.
V _{TT} PE	I	PCI Express Termination Power.
V _{SS}	I	Ground.

Table 1.6 Power and Ground Pins

Notes

Pin Characteristics

Note: Some input pads of the PES3T3 do not contain internal pull-ups or pull-downs. Unused inputs should be tied off to appropriate levels. This is especially critical for unused control signal inputs which, if left floating, could adversely affect operation. Also, any input pin left floating can cause a slight increase in power consumption.

Function	Pin Name	Type	Buffer	I/O Type	Internal Resistor	Notes
PCI Express Inter- face	PE0RN[0]	I	CML	Serial Link		
	PE0RP[0]	I				
	PE0TN[0]	O				
	PE0TP[0]	O				
	PE2RN[0]	I				
	PE2RP[0]	I				
	PE2TN[0]	O				
	PE2TP[0]	O				
	PE3RN[0]	I				
	PE3RP[0]	I				
	PE3TN[0]	O				
	PE3TP[0]	O				
	PEREFCLKN	I			LVPECL/ CML	Diff. Clock Input
	PEREFCLKP	I				
SMBus	MSMBCLK	I/O	LVTTTL	STI ¹		
	MSMBDAT	I/O		STI		
General Purpose I/O	GPIO[9,7,2:0]	I/O	LVTTTL	High Drive	pull-up	
System Pins	APWRDISN	I	LVTTTL	Input	pull-down	
	CCLKDS	I			pull-up	
	CCLKUS	I			pull-up	
	PERSTN	I				
	RSTHALT	I			pull-down	
	SWMODE[2:0]	I			pull-down	
	WAKEN	I/O			open-drain	
EJTAG / JTAG	JTAG_TCK	I	LVTTTL	STI	pull-up	
	JTAG_TDI	I		STI	pull-up	
	JTAG_TDO	O				
	JTAG_TMS	I		STI	pull-up	
	JTAG_TRST_N	I		STI	pull-up	

Table 1.7 Pin Characteristics

¹. Schmitt Trigger Input (STI).

Notes

System Identification

Vendor ID

All vendor ID fields in the device are hardwired to 0x111D which corresponds to Integrated Device Technology, Inc.

Device ID

The PES3T3 device ID is shown in Table 1.8.

PCIe Device	Device ID
0x1	0x8039

Table 1.8 PES3T3 Device ID

Revision ID

The PES3T3 revision ID is shown in Table 1.9.

Revision ID	Description
0x0F	Corresponds to ZA silicon
0x0E	Corresponds to ZB silicon

Table 1.9 PES3T3 Revision ID

JTAG ID

The JTAG ID is:

- Version: Same value as Revision ID. See Table 1.9
- Part number: Same value as base Device ID. See Table 1.8.
- Manufacturer ID: 0x33
- LSB: 0x1

Port Configuration

The PES3T3 supports three ports: one x1 upstream port and two x1 downstream ports. Figure 1.3 illustrates this configuration.

Notes

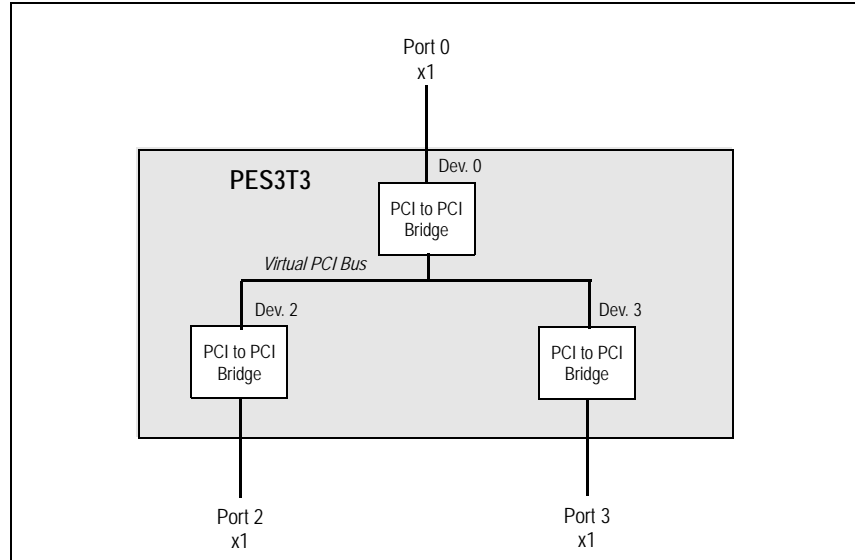

Figure 1.3 PES3T3 Port Configuration

Notes



Clocking, Reset, and Initialization

Notes

Introduction

The PES3T3 has a differential reference clock input that is used internally to generate all of the clocks required by the internal switch logic and the SerDes. The frequency of the reference clock is 100MHz. The reference clock differential inputs feeds several on-chip PLLs. Each PLL generates a 2.5 GHz clock which is used by several SerDes lanes and produces a 250 MHz core clock.

Clock Operation

When the CCLKUS and CCLKDS pins are asserted, they indicate that a common clock is being used between the upstream device and the upstream port, as well as between the downstream devices and the downstream ports. The Spread Spectrum Clock (SSC) must be disabled when the non-common clock is used on either the upstream port or downstream port. Figures 2.1 through 2.4 illustrate the operation of the CCLKUS and CCLKDS clocks using a common clock and a non-common clock.

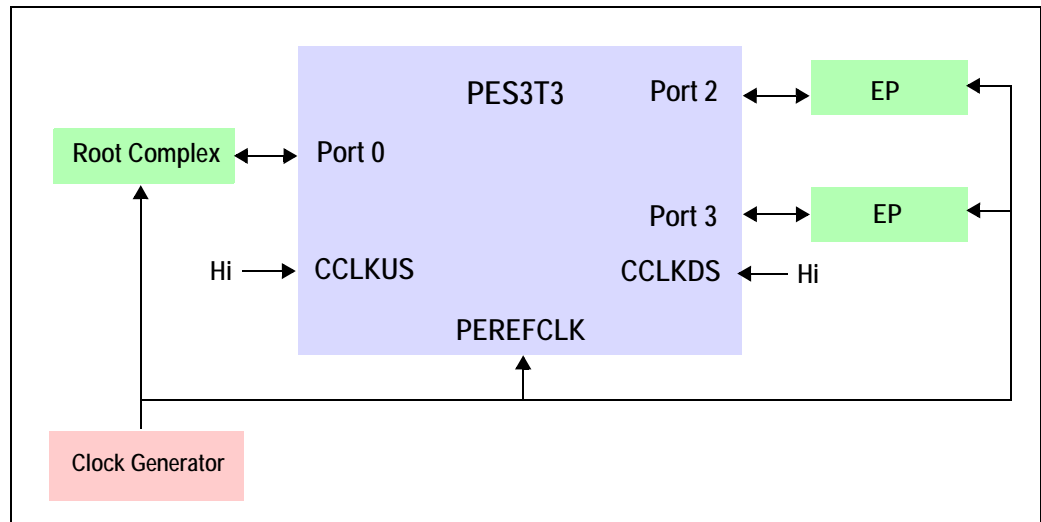

Figure 2.1 Common Clock on Upstream and Downstream (option to enable or disable Spread Spectrum Clock)

Notes

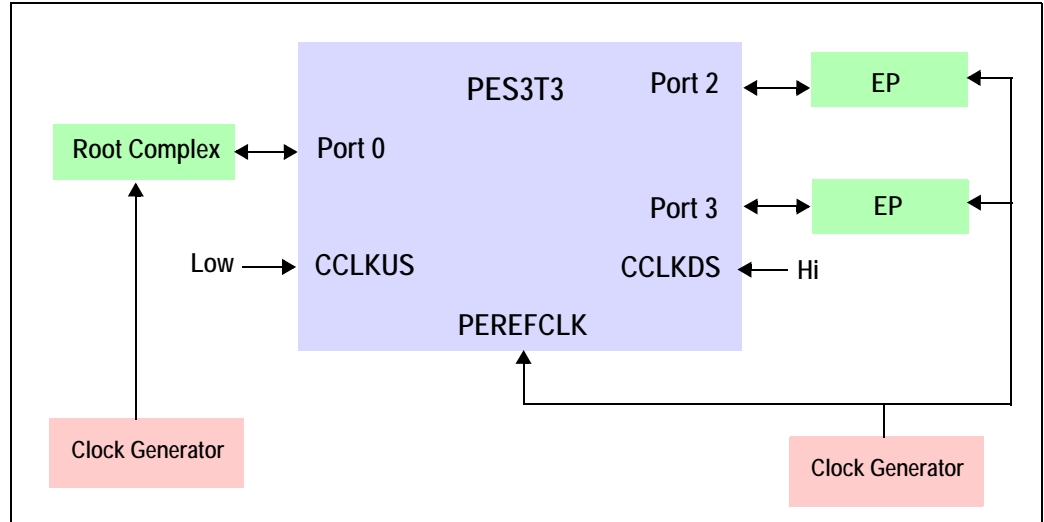

Figure 2.2 Non-Common Clock on Upstream; Common Clock on Downstream (must disable Spread Spectrum Clock)

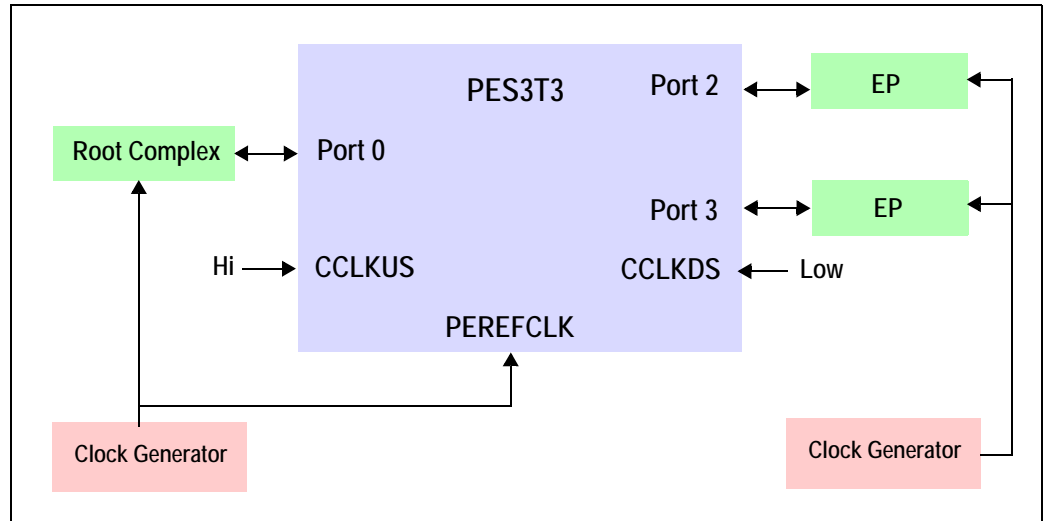

Figure 2.3 Common Clock on Upstream; Non-Common Clock on Downstream (must disable Spread Spectrum Clock)

Notes

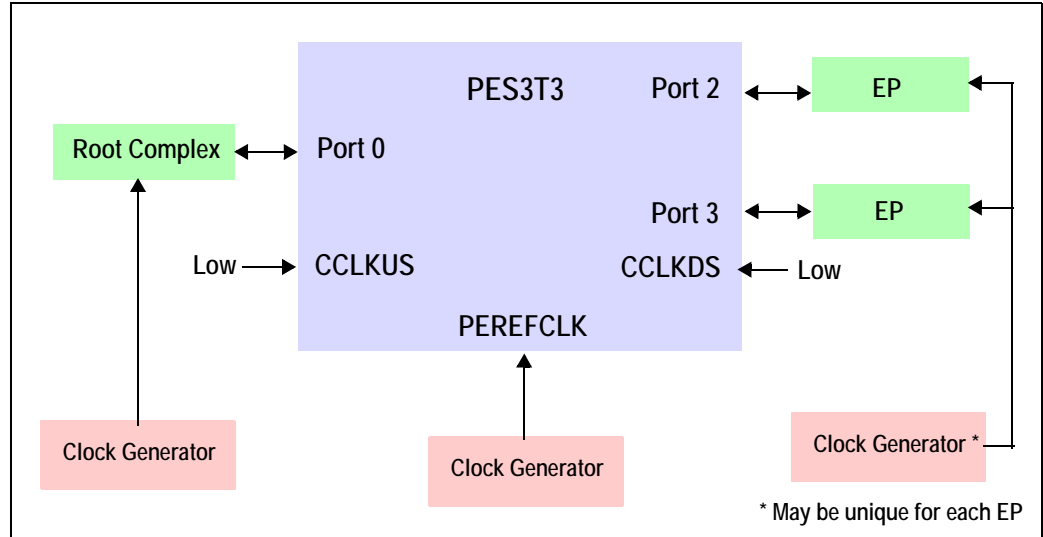

Figure 2.4 Non-Common Clock on Upstream and Downstream (must disable Spread Spectrum Clock)

Initialization

A boot configuration vector consisting of the signals listed in Table 2.1 is sampled by the PES3T3 during a fundamental reset when PERSTN is negated. The boot configuration vector defines essential parameters for switch operation. Since the boot configuration vector is sampled only during a fundamental reset sequence, the value of signals which make up the boot configuration vector is ignored during other times and their state outside of a fundamental reset has no effect on the operation of the PES3T3.

While basic switch operation may be configured using signals in the boot configuration vector, advanced switch features require configuration via an external serial EEPROM. The external serial EEPROM allows modification of any bit in any software visible register. See Chapter 6, SMBus Interfaces, for more information on the serial EEPROM.

The external serial EEPROM may be used to override the function of some of the signals in the boot configuration vector during a fundamental reset. The signals that may be overridden are noted in Table 2.1. The state of all of the boot configuration signals in Table 2.1 sampled during the most recent cold reset may be determined by reading the SWSTS register.

Notes

Signal	May Be Overridden	Description
CCLKDS	Y	Common Clock Downstream. The assertion of this pin indicates that all downstream ports are using the same clock source as that provided to downstream devices. This pin is used as the initial value of the Slot Clock Configuration bit in all of the Link Status Registers for downstream ports. The value may be overridden by modifying the SCLK bit in the downstream port's PCIELSTS register.
CCLKUS	Y	Common Clock Upstream. The assertion of this pin indicates that the upstream port is using the same clock source as the upstream device. This pin is used as the initial value of the Slot Clock Configuration bit in the Link Status Register for the upstream port. The value may be overridden by modifying the SCLK bit in the upstream port's PCIELSTS register.
RSTHALT	Y	Reset Halt. When this signal is asserted during a PCI Express fundamental reset, the PES3T3 executes the reset procedure and remains in a reset state with the Master SMBus active. This allows software to read and write registers internal to the device before normal device operation begins. The device exits the reset state when the RSTHALT bit is cleared in the SWCTL register through the SMBus master. The value may be overridden by modifying the RSTHALT bit in the SWCTL register.
SWMODE[2:0]	N	Switch Mode. These configuration pins determine the PES3T3 switch operating mode. 0x0 - Normal switch mode 0x1 - Normal switch mode with Serial EEPROM initialization 0x2 - through 0xF Reserve
APWRDISN	Y	Auxiliary Power Disable. If this signal is tied to logic '0' at the bootup time then the device is disabled to use auxiliary power and the associated logic on the chip is disabled. All the FRSticky bit values are reset to the default values.

Table 2.1 Boot Configuration Vector Signals

Reset

The PES3T3 defines four reset categories: fundamental reset, hot reset, upstream secondary bus reset, and downstream secondary bus reset.

- A fundamental reset causes all logic in the PES3T3 to be returned to an initial state.
- A hot reset causes all logic in the PES3T3 to be returned to an initial state, but does not cause the state of register fields denoted as "sticky" to be modified.
- An upstream secondary bus reset causes all devices on the virtual PCI bus to be hot reset except the upstream port (i.e., upstream PCI to PCI bridge).
- A downstream secondary bus reset causes a hot reset to be propagated on the corresponding external secondary bus link.

There are two sub-categories of fundamental reset: cold reset and warm reset. A cold reset occurs following a device being powered on and assertion of PERSTN. A warm reset is a fundamental reset that occurs without the removal of power.

Notes

Fundamental Reset

A fundamental reset may be initiated by any of the following conditions:

- A cold reset initiated by a power-on and the assertion of the PCI Express Reset (PERSTN) input pin. Refer to the device datasheet for power sequencing requirements.
- A warm reset initiated by the assertion of the PCI Express Reset (PERSTN) input pin while power is on.
- A warm reset initiated by the writing of a one to the Fundamental Reset (FRST) bit in the Switch Control (SWCTL) register.

When configured to operate in normal mode, the following reset sequence is executed.

1. Wait for the fundamental reset condition to clear (e.g., negation of PERSTN).
2. On negation of PERSTN, sample the boot configuration signals listed in Table 2.1. If PERSTN was not asserted, use the previously sampled boot configuration signal values (e.g., when a fundamental reset is the result of a one being written to the SWCTL register).
 - Examine the state of the sampled SWMODE[2:0] signals to determine the switch operating mode.
3. The PLL and SerDes are initialized.
4. Link training begins. While link training is in progress, proceed to step 5.
5. If the Reset Halt (RSTHALT) pin is asserted, the RSTHALT bit in the SWSTS register is set.
6. If the switch operating mode is not a test mode, the reset signal to the PCI Express stacks and associated logic is negated but they are held in a quasi-reset state in which the following actions occur.
 - All links enter an active link training state within 20ms of the clearing of the fundamental reset condition.
 - Within 100 ms of the clearing of the fundamental reset condition, all of the stacks are able to process configuration transactions and respond to these transactions with a configuration request retry status completion. All other transactions are ignored.
7. If the selected switch operating mode is one that requires initialization from the serial EEPROM, then the contents of the serial EEPROM are read and the appropriate PES3T3 registers are updated.
 - If a one is written by the serial EEPROM to the Full Link Retrain (FLRET) bit in any Phy Link State 0 (PHYLSTATE0) register, then link retraining is initiated on the corresponding port using the current link parameters.
 - If an error is detected during loading of the serial EEPROM, then loading of the serial EEPROM is aborted and the RSTHALT bit is set in the SWCTL register. Error information is recorded in the SMBUSSTS register.
 - When serial EEPROM initialization completes or when an error is detected, the DONE bit in the SMBUSSTS register is set.
8. If the Reset Halt (RSTHALT) bit is set in the SWCTL register, all of the logic is held in a reset state except the master SMBus, the control/status registers, and the stacks which continue to be held in a quasi-reset state and respond to configuration transactions with a retry. The device remains in this state until the RSTHALT bit is cleared. In this mode, an external agent may read and write any internal control and status registers and may access the external serial EEPROM via the EEPRO-MINTF register.
9. Normal device operation begins.

The PCIe base specification indicates that normal operation should begin within 1.0 second after a fundamental reset of a device. The reset sequence above guarantees that normal operation will begin within this period as long as the serial EEPROM initialization process completes within 200 ms. Under normal circumstances, 200 ms is more than adequate to initialize registers in the device even with a Master SMBus operating frequency of 100 KHz.

Notes

Serial EEPROM initialization may cause writes to register fields that initiate side effects such as link retraining. These side effects are initiated at the point at which the write occurs. Therefore, serial EEPROM initialization should be structured in a manner so as to ensure proper configuration prior to initiation of these side effects.

A warm reset initiated by the writing of a one to the Fundamental Reset (FRST) bit in the Switch Control (SWCTL) register always results in the PES3T3 returning a completion to the requester before the warm reset process begins.

The PES3T3 provides a reset output signal for each downstream port implemented as a GPIO alternate function. When a fundamental reset occurs, all of the GPIO pins default to GPIO inputs. Therefore, the downstream port resets are tri-stated. A system designer should use a pull-down on these signals if they are used as reset outputs.

The operation of a fundamental reset with serial EEPROM initialization (i.e., SWMODE[2:0] = 0x1) is illustrated in Figure 2.5.

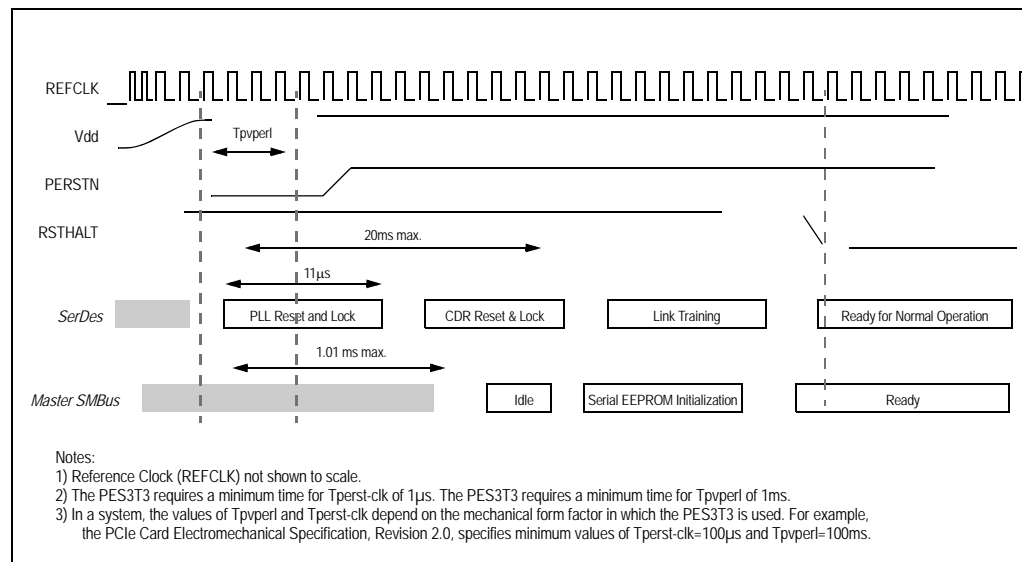

Figure 2.5 Fundamental Reset with Serial EEPROM initialization

Hot Reset

A hot reset may be initiated by any of the following conditions:

- Reception of TS1 ordered-sets on the upstream port indicating a hot reset.
- Data link layer of the upstream port transitions to the DL_Down state.
- Writing a one to the Hot Reset (HRST) bit in the Switch Control (SWCTL) register.

The initiation of a hot reset due to the data link layer of the upstream port transitioning to the DL_Down state may be disabled by setting the Disable Link Down Hot Reset (DL_DHRST) bit in the Switch Control (SWCTL) register. Other hot reset conditions are unaffected by this bit.

Notes

When a hot reset occurs, the following sequence is executed.

1. Each downstream port whose link is up propagates the hot reset by transmitting TS1 ordered sets with the hot reset bit set.
2. All of the logic associated with the PES3T3 is reset except the PLLs, SerDes, and master SMBus interface.
3. All registers fields in all registers, except those denoted as "sticky" or Read and Write when Unlocked (i.e., RWL), are reset to their initial value. The value of fields denoted as "sticky" or RWL is preserved across a hot reset.
4. Link training begins. While link training is in progress, proceed to step 5.
5. The PCI Express stacks and associated logic are held in a quasi-reset state in which the following actions occur.

All links enter an active link training state within 20ms of the clearing of the hot reset condition.

Within 100 ms of the clearing of the fundamental reset condition, all of the stacks are able to process configuration transactions and respond to these transactions with a configuration request retry status completion. All other transactions are ignored.

6. If the selected switch operating mode is one that requires initialization from the serial EEPROM and the Disable Hot Reset Serial EEPROM Initialization (DHRSTSEI) bit is not set in the Switch Control (SWCTL) register, then the contents of the serial EEPROM are read and the appropriate PES3T3 registers are updated.

If a one is written by the serial EEPROM to the Full Link Retrain (FLRET) bit in the Phy Link State 0 (PHYLSTATE0) register, then link retraining is initiated on the corresponding port using the current link parameters.

If an error is detected during loading of the serial EEPROM, then loading of the serial EEPROM is aborted and the RSTHALT bit is set in the SWCTL register. Error information is recorded in the SMBUSSTS register.

When serial EEPROM initialization completes or when an error is detected, the DONE bit in the SMBUSSTS register is set.

7. If the Reset Halt (RSTHALT) bit is set in the SWCTL register, all of the logic is held in a reset state except the master SMBus. The RSTHALT bit is only set if serial EEPROM initialization is enabled in step 6.

8. Normal device operation begins.

A hot reset initiated by the writing of a one to the Hot Reset (HRST) bit in the Switch Control (SWCTL) register always results in the PES3T3 returning a completion to the requester before the hot reset process begins.

Upstream Secondary Bus Reset

An upstream secondary bus reset may be initiated by the following condition:

- A one is written to the Secondary Bus Reset (SRESET) bit in the upstream port's (i.e., port 0) Bridge Control Register (BCTL).

Notes

When an upstream secondary bus reset occurs, the following sequence is executed.

1. Each downstream port whose link is up propagates the reset by transmitting TS1 ordered sets with the hot reset bit set.
2. All register fields in all registers associated with downstream ports, except those denoted as “sticky” or Read and Write when Unlocked (i.e, RWL), are reset to their initial value. The value of fields denoted as “sticky” or RWL is unaffected by an upstream secondary bus reset.
3. All TLPs received from downstream ports and queued in the PES3T3 are discarded.
4. Logic in the stack, application layer, and switch core associated with the downstream ports are gracefully reset.
5. Wait for the Secondary Bus Reset (SRESET) bit in the upstream port’s Switch Control Register (SWCTL) to clear.
6. Normal downstream port operation begins.

The operation of the upstream port is unaffected by a secondary bus reset. The link remains up and Type 0 configuration read and write transactions that target the upstream port complete normally. During an upstream secondary bus reset, all TLPs destined to the secondary side of the upstream port’s PCI-to-PCI bridge are treated as unsupported requests.

Downstream Secondary Bus Reset

A downstream secondary bus reset may be initiated by the following condition:

- A one is written to the Secondary Bus Reset (SRESET) bit in the port’s (i.e., port 0) Bridge Control Register (BCTRL).

When a downstream secondary bus reset occurs, the following sequence is executed.

1. If the corresponding downstream port’s link is up, TS1 ordered sets with the hot reset bit set are transmitted.
2. All TLPs received from corresponding downstream port and queued in the PES3T3 are discarded.
3. Wait for the Secondary Bus Reset (SRESET) bit in the upstream port’s Switch Control Register (SWCTL) to clear.
4. Normal downstream port operation begins.

The operation of the upstream port is unaffected by a downstream secondary bus reset. The operation of other downstream ports is unaffected by a downstream secondary bus reset. During a downstream secondary bus reset, Type 0 configuration read and write transactions that target the downstream port complete normally. During a downstream secondary bus reset, all TLPs destined to the secondary side of the downstream port’s PCI-to-PCI bridge are treated as unsupported requests.

Downstream Port Reset Outputs

Individual downstream port reset outputs (P2RSTN and P3RSTN) are provided as GPIO pin alternate functions. Following a fundamental reset, all of the GPIO pins default to GPIO inputs. Therefore, the downstream port resets are tri-stated. A system designer should use a pull-down on these signals if they are used as reset outputs. The PES3T3 ensures through hardware that the minimum P_xRSTN assertion pulse width is no less than 200 μs.

Downstream port reset outputs can be configured to operate in one of three modes. These modes are: power enable controlled reset output, power good controlled reset output, and hot reset controlled output. The downstream port reset output mode is determined by the Reset Mode (RSTMODE) field in the Hot-Plug Configuration Control (HPCFGCTL) register.

Power Enable Controlled Reset Output

In this mode, a downstream port reset output state is controlled as a side effect of the slot power being turned on or off. The operation of this mode is illustrated in Figure 2.6. A downstream port’s slot power is controlled by the Power Controller Control (PCC) bit in the PCI Express Slot Control (PCIESCTL) register.

Notes

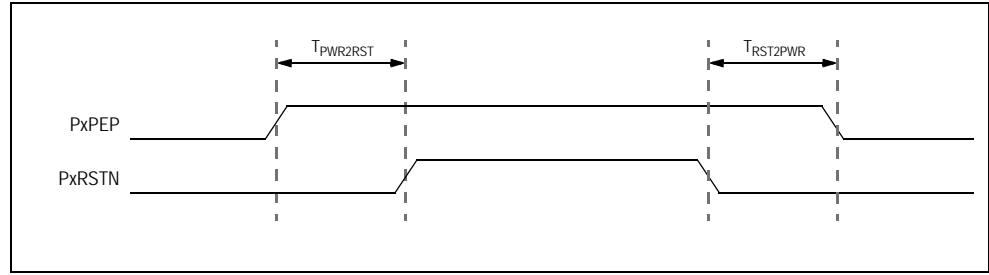

Figure 2.6 Power Enable Controlled Reset Output Mode Operation

While slot power is disabled, the corresponding downstream port reset output is asserted.

When slot power is enabled by writing a zero to the PCC bit, the Port x Power Enable Output (PxPEP) is asserted and then power to the slot is enabled and the corresponding downstream port reset output is negated. The time between the assertion of the PxPEP signal and the negation of the PxRSTN signal is controlled by the value in the Slot Power to Reset Negation (PWR2RST) field in the HPCFGCTL register.

While slot power is enabled, the corresponding downstream port reset output is negated.

When slot power is disabled by writing a one to the PCC bit, the corresponding downstream port reset output is asserted and then slot power is disabled. The time between the assertion of the PxRSTN signal and the negation of the PxPEP signal is controlled by the value in the Reset Negation to Slot Power (RST2PWR) field in the HPCFGCTL register.

Power Good Controlled Reset Output

As in the Power Enable Controlled Reset mode, in this mode a downstream port reset output state is controlled as a side effect of slot power being turned on or off. However, the timing in this mode depends on the power good state of the slot's power supply. The operation of this mode is illustrated in Figure 2.7.

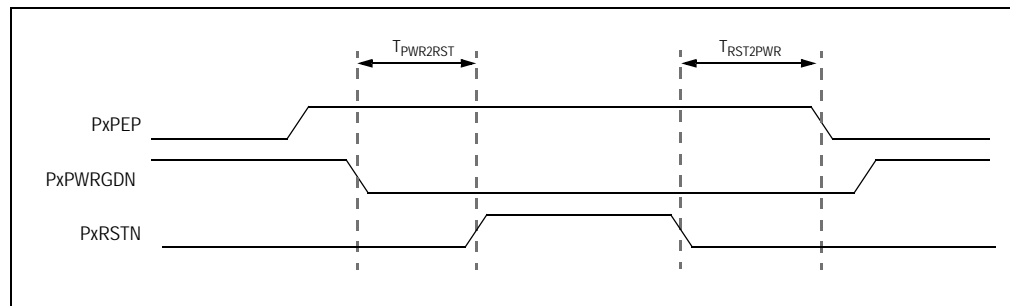

Figure 2.7 Power Good Controlled Reset Output Mode Operation

The operation of this mode is similar to that of the Power Enable Controlled Reset mode except that when power is enabled, the negation of the corresponding port reset output occurs as a result of and after assertion of the slot's Power Good (PxPWRGDN) signal is observed. The time between the assertion of the PxPWRGDN signal and the negation of the PxRSTN signal is controlled by the value in the Slot Power to Reset Negation (PWR2RST) field in the HPCFGCTL register.

When slot power is disabled by writing a one to the PCC bit, the corresponding downstream port reset output is asserted and then slot power is disabled. The time between the assertion of the PxRSTN signal and the negation of the PxPEP signal is controlled by the value in the Reset Negation to Slot Power (RST2PWR) field in the HPCFGCTL register.

Notes

If at any point while a downstream port is not being reset (i.e., P_xRSTN is negated) a power fault is detected (i.e., P_xPWRGDN is negated), the corresponding port reset output is immediately asserted. Since the P_xPWRGDN signal is an I/O expander input, it may not be possible to meet a profiled power level invalid to reset asserted timing specification (i.e., P_xPWRGDN to P_xRSTN). Systems that require a shorter time interval may implement this functionality external to the PES3T3.

Hot Reset Controlled Reset Output

In this mode the following conditions cause a downstream port's reset output to be asserted.

- Hot reset
- Upstream secondary bus reset
- Downstream secondary bus reset

When a downstream port reset output is asserted it remains asserted as long as one of the above conditions persists or 200 μ s, whichever is longer.



Theory of Operation

Notes

Port Interrupts

The upstream port (Port 0) generates legacy interrupts and MSIs to report internal switch errors such as parity errors and errors in reading configuration registers. Downstream ports support generation of legacy interrupts and MSIs. The following are sources of downstream port interrupts and MSIs.

- Downstream port's hot-plug controller
- Link bandwidth notification capability (i.e., assertion of the LBWSTS or LABWSTS bits in the PCIELSTS register when interrupt notification is enabled for these bits)

When a downstream port is configured to generate INTx messages, only INTA is used. When an unmasked interrupt condition occurs, then an MSI or interrupt message is generated by the corresponding port as described in Table 3.1. The removal of the interrupt condition occurs when unmasked status bit(s) causing the interrupt are masked or cleared.

The PES3T3 assumes that all downstream port generated MSIs are targeted to the root and routes these transactions to the upstream port. Configuring the address contained in a downstream port's MSIADDR and MSIADDRU registers to an address that does not route to the upstream port and generating an MSI produces undefined results.

Unmasked Interrupt	EN bit in MSICAP Register	INTXD bit in PCICMD Register	Action
Asserted	1	X	MSI message generated
	0	0	Assert_INTA message request generated to switch core
	0	1	None
Negated	1	X	None
	0	0	Deassert_INTA message request generated to switch core
	0	1	None

Table 3.1 Downstream Port Interrupts

Since memory error reporting via interrupts is an optional capability, the MSI capability structure associated with the upstream port is not by default part of the PCI capability structure link list located in the upstream port's configuration space. This capability may be added to the capability structure linked list by using the serial EEPROM, SMBus or the Root to unlock registers and setting the Next Pointer (NXTPTR) field in the PCI Power Management Capabilities (PMCAP) register to 0xD0.

Legacy Interrupt Emulation

The PES3T3 supports legacy PCI INTx emulation. Rather than use sideband INTx signals, PCIe defines two messages that indicate the assertion and negation of an interrupt signal. An Assert_INTx message is used to signal the assertion of an interrupt signal and an Deassert_INTx message is used to signal its negation.

Notes

The PES3T3 maintains an aggregated INTx state for each of the four interrupt signals (i.e., A through D) at each port.

- The value of the INTA, INTB, INTC and INTD aggregated state for the entire switch may be determined by examining the corresponding field in the upstream port's Interrupt Status (P0_INTSTS) register.
- The aggregated INTx state for a downstream port may be determined by reading the corresponding field in the port's Interrupt Status (Px_INTSTS) register. This register contains the aggregated state of interrupts generated by that port (i.e., hot-plug) plus interrupt messages received from the downstream link partner. The interrupt state reflects the state of interrupts as seen by that port (i.e., before downstream port interrupts are mapped to upstream port interrupts).

An Assert_INTx message is sent to the root by the upstream port (i.e., port 0), when the aggregated state of the corresponding interrupt in the upstream port transitions from a negated to an asserted state. A Deassert_INTx message is sent to the root by the upstream port when the aggregated state of the corresponding interrupt in the upstream port transitions from an asserted to a negated state.

PCI to PCI bridges must map interrupts on the secondary side of the bridge according to the device number of the device on the secondary side of the bridge. No mapping is performed for the PCI to PCI bridges corresponding to downstream ports as these ports only connect to device zero. A mapping is performed for the upstream port (i.e., port 0). This mapping for the PES3T3 is summarized in Table 3.2.

		Upstream Port Interrupt (Port 0)			
		INTA	INTB	INTC	INTD
Downstream Port ¹ Interrupt	Port 2	INTC	INTD	INTA	INTB
	Port 3	INTB	INTC	INTD	INTA

Table 3.2 PES3T3 Downstream to Upstream Port Interrupt Routing

¹ Port X INTy corresponds to external downstream generated INTy interrupts and INTy interrupts generated by the port.

If a Downstream Port goes to DL_Down status, the INTx virtual wires associated with that port are negated, and the upstream port's aggregate state is updated accordingly. This may result in the upstream port generating a Deassert_Intx message.



Link Operation

Notes

Introduction

The PES3T3 is a 3 port switch device. The upstream port link width is configured as a x1 link width and both downstream ports are also configured as x1 link widths.

Polarity Inversion

Each port of the PES3T3 supports automatic polarity inversion as required by the PCIe specification. Polarity inversion is a function of the receiver and not the transmitter. The transmitter never inverts its data. During link training, the receiver examines symbols six through sixteen of the TS1 and TS2 ordered sets for inversion of the PEXAP[n] and PEXAN[n] signals. If an inversion is detected, then logic for the receiving lane automatically inverts received data.

Polarity inversion is a lane and not a link function. Therefore, it is possible for some linked lanes to be inverted while others are not inverted.

Link Width Negotiation

The PES3T3 supports the optional link variable width negotiation feature for its upstream port as outlined in the PCIe specification. During link training, upstream port is capable of negotiating to a x1 link width. The negotiated width of the upstream link may be determined from the Link Width (LW) field in the PCI Express Link Status (PCIELSTS) register.

The Maximum Link Width (MAXLNKWDTH) field in a port's PCI Express Link Capabilities (PCIELCAP) register contains the maximum link width of the port. This field is of RWL type in the upstream port and may be modified when the REGUNLOCK bit is set in the SWCTL register. Modification of this field allows the maximum link width of the port to be configured. The new link width takes effect the next time link training occurs. To force a link width for the upstream port to a smaller width than the default value, the MAXLNKWDTH field could be configured through Serial EEPROM initialization and full link retraining forced.

Link Retraining

Link retraining should not cause either a downstream component or an upstream component to reset or revert to default values.

Writing a one to the Link Retrain (LRET) bit in the upstream port's PCI Express Link Control (PCIELCTL) register when the REGUNLOCK bit is set in the SWCTL register forces the upstream PCIe link to retrain. When this occurs the LTSSM transitions directly to the Recovery state.

Writing a one to the Link Retrain (LRET) bit in a downstream port's PCI Express Link Control (PCIELCTL) register regardless of the REGUNLOCK bit state in the SWCTL register forces the downstream PCIe link to retrain. When this occurs the LTSSM transitions directly to the Recovery state.

Writing a one to the Full Link Retrain (FLRET) bit in the Phy Link State 0 (PHYLSTSE 0) register of any port forces that port's PCIe link to retrain. When this occurs the LTSSM transitions directly to the Detect state.

Link Down

When a link goes down, all TLPs received by that port and queued in the switch are discarded and all TLPs received by other ports and destined to the port whose link is down are treated as Unsupported Requests (UR). While a downstream link is down, it is possible to perform configuration read and write operations to the PCI-PCI bridge associated with that link. When a link comes up, flow control credits are advertised.

Notes

Slot Power Limit Support

The Set_Slot_Power_Limit message is used to convey a slot power limit value from a downstream switch port or root port to the upstream port of a connected device or switch.

Upstream Port

When a Set_Slot_Power_Limit message is received by the upstream switch port, the fields in the message are written to the PCI Express Device Capabilities (PCIEDCAP) register of that port.

- Byte 0 bits 7:0 of the message payload are written to the Captured Slot Power Limit Scale (CSPLS) field.
- Byte 1 bits 1:0 of the message payload are written to the Captured Slot Power Limit Value (CSPLV) field.

Downstream Port

A Set_Slot_Power_Limit message is sent by downstream switch ports when either of the following events occur.

- A configuration write is performed to the corresponding PCIESCAP register when the link associated with the downstream port is up.
- A link associated with the downstream port transitions from a non-operational state to an operational (i.e., up) state.

Link States

The PES3T3 supports the following link states:

- L0
Fully operational link state
- L0s
Automatically entered low power state with shortest exit latency
- L1
Lower power state than L0s
May be automatically entered or directed by software by placing the device in the D3_{hot} state
- L2/L3 Ready
The L2/L3 state is entered after the acknowledgement of a PM_Turn_Off Message
There is no TLP or DLLP communications over a link in this state
- L2
The main power and reference clock are turned off but the auxiliary voltage is turned on. The PES3T3 only exits this state when fundamental reset is applied (i.e., the PERSTN pin is asserted).
- L3
Link is completely unpowered and off
- Link Down
A transitional link down pseudo-state prior to L0. This pseudo-state is associated with the LTSSM Detect, Polling, Configuration, Disabled, Loopback, and Hot-Reset states.

Notes

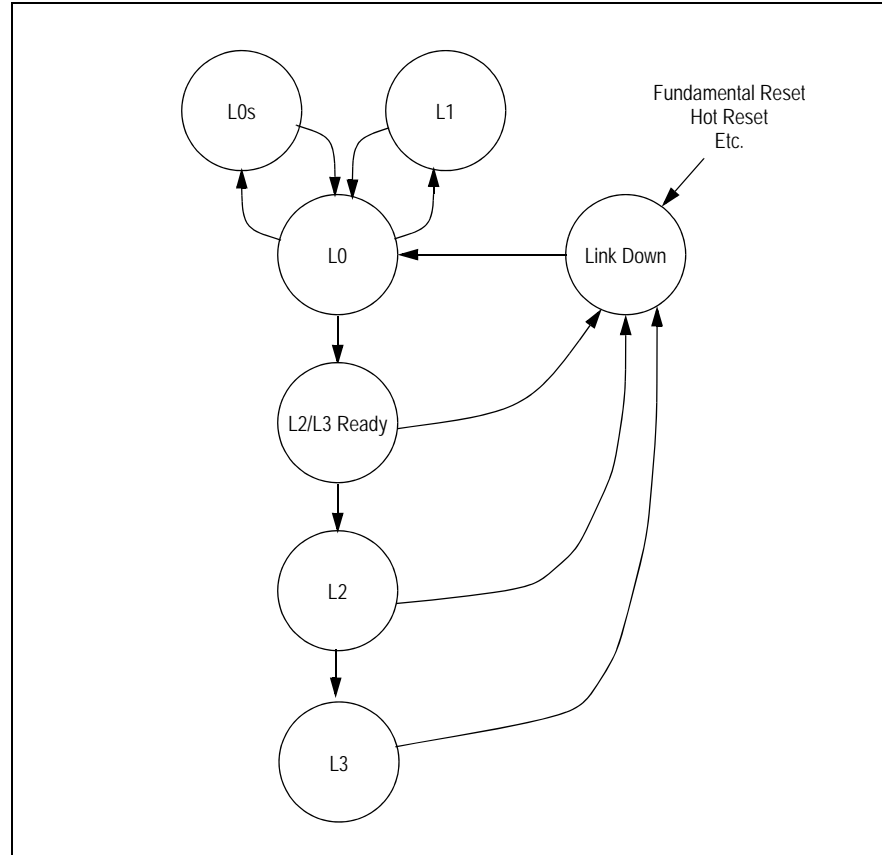

Figure 4.1 PES3T3 ASPM Link State Transitions

Active State Power Management

The operation of Active State Power Management (ASPM) is orthogonal to power management. Once enabled by the ASPM field in the PCI Express Link Control (PCIELCTL) register, ASPM link state transitions are initiated by hardware without software involvement.

The PES3T3 ASPM supports the required L0s state as well as the optional L1 state. The L0s Entry Timer (LOET) field in the PCI Power Management Proprietary Control (PMPC) register controls the amount of time L0s entry conditions must be met before the hardware transitions the link to the L0s state.

- The upstream switch port has the following L0s entry conditions.
 - The receive lane of all of the switch downstream ports which are not in a low power state (i.e., D3) and whose link is not down are in the L0s state.
 - The switch has no TLPs to transmit on the upstream port or there are no available flow control credits to transmit a TLP.
 - There are no DLLPs pending for transmission on the upstream port.
- The downstream switch ports have the following L0s entry conditions.
 - The receive lane of the switch upstream port is in the L0s state.
 - The switch has no TLPs to transmit on the downstream port or there are no available flow control credits to transmit a TLP.
 - There are no DLLPs pending for transmission on the downstream port.

The L1 Entry Timer (L1ET) field in the PCI Power Management Proprietary Control (PMPC) register controls the amount of time L1 entry conditions must be met before the hardware transitions the link to the L1 state. If these conditions are met and the link is in the L0 or L0s states, the hardware will request a tran-

Notes

sition to the L1 state from its link partner. Note that L1 entry requests are only made by the PES3T3 upstream port. If the link partner acknowledges the transition, the L1 state is entered. Otherwise the L0s state is entered.

- The upstream switch port will only request entry into the L1 state when all of the downstream ports which are not in a low power state (i.e., D3) and whose link is not down are in the L1 state.

Link Status

Associated with each port is a Port Link Up (PxLINKUPN) status output and a Port Activity (PxACTIVEN) status output. These outputs are provided on I/O expander 4. See section I/O Expanders on page 6-5 for the operation of the I/O expander and the mapping of these status outputs to I/O expander pins.

The PxLINKUPN and PxACTIVEN status outputs may be used to provide a visual indication of system state and activity or for debug. The PxLINKUPN output is asserted when the PCI Express data link layer is up (i.e., when the LTSSM is in the L0, L0s, L1 or recovery states). When the data link layer is down, this output is negated. The PxACTIVEN output is asserted whenever any TLP, other than a vendor defined message, is transmitted or received on the corresponding port's link. Whenever a PxACTIVEN output is asserted, it remains asserted for at least 200 ms. Since an I/O expander output may change no more frequently than once every 40 ms, this translates into five I/O expander update periods.



General Purpose Inputs/Outputs

Notes

Introduction

The PES3T3 has five General Purpose I/O (GPIO) pins that may be individually configured as: general purpose inputs, general purpose outputs, or alternate functions. GPIO pins are controlled by the General Purpose I/O Function (GPIOFUNC), General Purpose I/O Configuration (GPIOCFG), and General Purpose I/O Data (GPIOD) registers in the upstream port's PCI configuration space. As shown in Table 5.1, four of the five GPIO pins are shared with another on-chip function. The GPIO Function (GPIOFUNC) register determines whether a GPIO bit operates as a general purpose I/O or as the specified alternate function.

GPIO Pin	Alternate Function Pin Name	Alternate Function Description	Alternate Function Pin Type
0	PE2RSTN	Reset output for downstream port 2	Output
2	IOEXPINTN0	SMBus I/O expander interrupt 0	Input
7	GPEN	General purpose event output	Output
9	PE3RSTN	Reset output for downstream port 3	Output

Table 5.1 General Purpose I/O Pin Alternate Function

After reset, all GPIO pins default to the GPIO input function. GPIO pins configured as GPIO inputs are sampled no more frequently than once every 128 ns and may be treated as asynchronous inputs. When a GPIO pin is configured to use the GPIO function, the unneeded alternate function associated with the pin is held in an inactive state by internal logic. Care should be exercised when configuring the GPIO pins as outputs since an incorrect configuration could cause damage to external components as well as the PES3T3.

GPIO Configuration

Associated with each GPIO pin is a bit in the GPIOFUNC, GPIOCFG and GPIOD registers. Table 5.2 summarizes the configuration of GPIO pins.

GPIOFUNC	GPIOCFG	Pin Function
0	0	GPIO input
0	1	GPIO output
1	don't care	Alternate function

Table 5.2 GPIO Pin Configuration

GPIO Pin Configured as an Input

When configured as an input in the GPIOCFG register and as a GPIO function in the GPIOFUNC register, the GPIO pin is sampled and registered in the GPIOD register. The value of the input pin can be determined at any time by reading the GPIOD register. Note that the value in this register corresponds to the value of the pin irrespective of whether the pin is configured as a GPIO input, GPIO output, or alternate function.

Notes

GPIO Pin Configured as an Output

When configured as an output in the GPIOCFG register and as a GPIO function in the GPIOFUNC register, the value in the corresponding bit position of the GPIOD register is driven on the pin. System designers should treat the GPIO outputs as asynchronous outputs. The actual value of the output pin can be determined by reading the GPIOD register.

GPIO Pin Configured as an Alternate Function

When configured as an alternate function in the GPIOFUNC register, the pin behaves as described by the section associated with that function. The value of the alternate function pin can be determined at any time by reading the GPIOD register.

Notes



SMBus Interfaces

Notes

Introduction

The PES3T3 contains one Master SMBus interface. This interface provides connection for an optional external serial EEPROM used for initialization and optional external I/O expanders. Two pins make up the master SMBus interface: the SMBus clock pin and the SMBus data pin.

Master SMBus Interface

The master SMBus interface is used during a fundamental reset to load configuration values from an optional serial EEPROM. It is also used to support optional I/O expanders used for hot-plug and other status signals.

Initialization

Master SMBus initialization occurs during a fundamental reset (see section Fundamental Reset on page 2-5). The Master SMBus Clock Prescaler (MSMBCP) field in the SMBus Control (SMBUSCTL) register is configured to support 100 KHz SMBus operation.

Serial EEPROM

During a fundamental or hot reset, an optional serial EEPROM may be used to initialize any software visible register in the device. Serial EEPROM loading occurs if the Switch Mode (SWMODE[2:0]) field selects an operating mode that performs serial EEPROM initialization. The address used by the SMBus interface to access the serial EEPROM is set to a default value of 1010000b.

Device Initialization from a Serial EEPROM

During initialization from the optional serial EEPROM, the master SMBus interface reads configuration blocks from the serial EEPROM and updates corresponding registers in the PES3T3. Any PES3T3 software visible register in any port may be initialized with values stored in the serial EEPROM. Each software visible register in the PES3T3 has a CSR system address which is formed by adding the PCI configuration space offset value of the register to the base address of the configuration space in which the register is located. Configuration blocks stored in the serial EEPROM use this CSR system address shifted right two bits (i.e., configuration blocks in the serial EEPROM use doubleword CSR system addresses and not byte CSR system addresses).

Base addresses for the PCI configuration spaces in the PES3T3 are listed in Chapter 9, Table 9.1, Base Addresses for Port Configuration Space Registers. Since configuration blocks are used to store only the value of those registers that are initialized, a serial EEPROM much smaller than the total size of all of the configuration spaces may be used to initialize the device. Any serial EEPROM compatible with those listed in Table 6.1 may be used to store the PES3T3 initialization values. Some of these devices are larger than the total size of all of the PCI configuration spaces in the PES3T3 that may be initialized and thus may not be fully utilized.

Serial EEPROM	Size
24C32	4 KB
24C64	8 KB

Table 6.1 PES3T3 Compatible Serial EEPROMs

Notes

Serial EEPROM	Size
24C128	16 KB
24C256	32 KB
24C512	64 KB

Table 6.1 PES3T3 Compatible Serial EEPROMs

During serial EEPROM initialization, the master SMBus interface begins reading bytes starting at serial EEPROM address zero. These bytes are interpreted as configuration blocks and sequential reading of the serial EEPROM continues until the end of a configuration done block is reached or the serial EEPROM address rolls over from 0xFFFF to 0x0. All register initialization performed by the serial EEPROM is performed in double word quantities.

There are three configuration block types that may be stored in the serial EEPROM. The first type is a single double word initialization sequence. A double word initialization sequence occupies six bytes in the serial EEPROM and is used to initialize a single double word quantity in the PES3T3. A single double word initialization sequence consists of three fields and its format is shown in Figure 6.1. The CSR_SYSADDR field contains the double word CSR system address of the double word to be initialized. The actual CSR system address, which is a byte address, equals this value with two lower zero bits appended. The next field is the TYPE field that indicates the type of the configuration block. For single double word initialization sequence, this value is always 0x0. The final DATA field contains the double word initialization value.

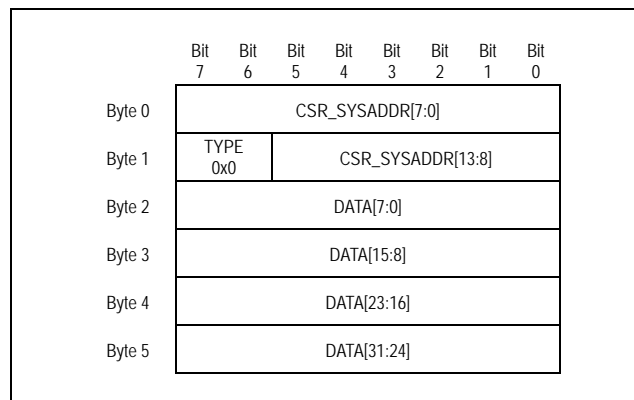

Figure 6.1 Single Double Word Initialization Sequence Format

The second type of configuration block is the sequential double word initialization sequence. It is similar to a single double word initialization sequence except that it contains a double word count that allows multiple sequential double words to be initialized in one configuration block.

A sequential double word initialization sequence consists of four required fields and one to 65535 double word initialization data fields. The format of a sequential double word initialization sequence is shown in Figure 6.2. The CSR_SYSADDR field contains the starting double word CSR system address to be initialized. The next field is the TYPE field that indicates the type of the configuration block. For sequential double word initialization sequences, this value is always 0x1. The NUMDW field specifies the number of double words initialized by the configuration block. This is followed by the number of DATA fields specified in the NUMDW field.

Notes

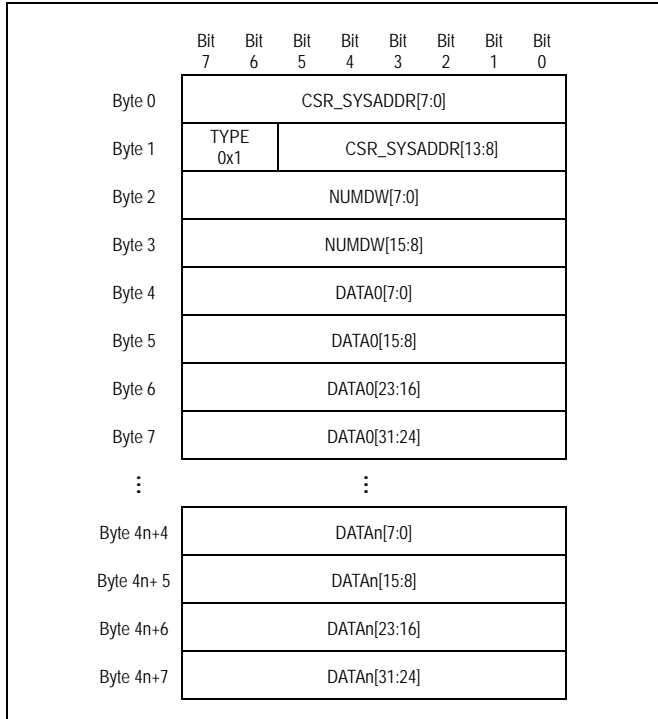

Figure 6.2 Sequential Double Word Initialization Sequence Format

The final type of configuration block is the configuration done sequence which is used to signify the end of a serial EEPROM initialization sequence. If during serial EEPROM initialization, an attempt is made to initialize a register that is not defined in a configuration space (i.e., not defined in Chapter 9, Configuration Registers on page 9-1), then the Unmapped Register Initialization Attempt (URIA) bit is set in the SMBUSSTS register and the write is ignored.

The configuration done sequence consists of two fields and its format is shown in Figure 6.2. The CHECKSUM field contains the checksum of all of the bytes in all of the fields read from the serial EEPROM from the first configuration block to the end of this done sequence. The second field is the TYPE field which is always 0x3 for configuration done sequences.

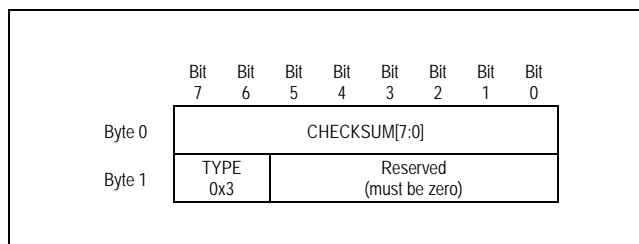

Figure 6.3 Configuration Done Sequence Format

The checksum in the configuration done sequence enables the integrity of the serial EEPROM initialization to be verified. Since uninitialized EEPROMs typically have a value of all ones, initialization from an uninitialized serial EEPROM will result in a checksum mismatch. The checksum is computed in the following manner. An 8-bit counter is initialized to zero and the 8-bit sum is computed over the configuration bytes stored in the serial EEPROM, including the entire contents of the configuration done sequence, with the checksum field initialized to zero.¹ The 1's complement of this sum is placed in the checksum field.

¹ This includes the byte containing the TYPE field.

Notes

The checksum is verified in the following manner. An 8-bit counter is cleared and the 8-bit sum is computed over the bytes read from the serial EEPROM, including the entire contents of the configuration done sequence.¹ The correct result should always be 0xFF (i.e., all ones). Checksum checking may be disabled by setting the Ignore Checksum Errors (ICHECKSUM) bit in the SMBus Control (SMBUSCTL) register.

If an error is detected during loading of the serial EEPROM, then loading of the serial EEPROM is aborted and the RSTHALT bit is set in the SWCTL register. This prevents normal system operation with a potentially incorrectly initialized device. Error information is recorded in the SMBUSSTS register. Once serial EEPROM initialization completes, or when an error is detected, the EEPROM Done (EEPROM-DONE) bit is set in the SMBus Status (SMBUSSTS) register. A summary of possible errors during serial EEPROM initialization and specific action taken when detected is summarized in Table 6.2.

Error	Action Taken
Configuration Done Sequence checksum mismatch with that computed by the PES3T3	- Set RSTHALT bit in SWCTL register - ICSERR bit is set in the SMBUSSTS register - Abort initialization, set DONE bit in the SMBUSSTS register
Serial EEPROM address roll-over from 0xFFFF to 0x0000	- Set RSTHALT bit in SWCTL register - ICSERR bit is set in the SMBUSSTS register - Abort initialization, set DONE bit in the SMBUSSTS register
Invalid configuration block type (only invalid type is 0x2)	- Set RSTHALT bit in SWCTL register - ICSERR bit is set in the SMBUSSTS register - Abort initialization, set DONE bit in the SMBUSSTS register
An unexpected NACK is observed during a master SMBus transaction	- Set RSTHALT bit in SWCTL register - NAERR bit is set in the SMBUSSTS register - Abort initialization, set DONE bit in the SMBUSSTS register
Master SMBus interface loses 16 consecutive arbitration attempts	- Set RSTHALT bit in SWCTL register - LAERR bit is set in the SMBUSSTS register - Abort initialization, set DONE bit in the SMBUSSTS register
A misplaced START or STOP condition is detected by the master SMBus interface	- Set RSTHALT bit in SWCTL register - OTHERERR bit is set in the SMBUSSTS register - Abort initialization, set DONE bit in the SMBUSSTS register

Table 6.2 Serial EEPROM Initialization Errors

Programming the Serial EEPROM

The serial EEPROM may be programmed prior to board assembly or in-system via a PCIe root. A PCIe root may read and write the serial EEPROM by performing configuration read and write transactions to the Serial EEPROM Interface (EEPROMINTF) register. To read a byte from the serial EEPROM, the root should configure the Address (ADDR) field in the EEPROMINTF register with the byte address of the serial EEPROM location to be read and the Operation (OP) field to “read.” The Busy (BUSY) bit should then be checked. If the EEPROM is not busy, then the read operation may be initiated by performing a write to the Data (DATA) field. When the serial EEPROM read operation completes, the Done (DONE) bit in the EEPROMINTF register is set and the busy bit is cleared. When this occurs, the DATA field contains the byte data of the value read from the serial EEPROM.

To write a byte to the serial EEPROM, the root should configure the ADDR field with the byte address of the serial EEPROM location to be written and set the OP field to “write.” If the serial EEPROM is not busy (i.e., the BUSY bit is cleared), then the write operation may be initiated by writing the value to be written to the DATA field. When the write operation completes, the DONE bit is set and the busy bit is cleared.

¹ This includes the checksum byte as well as the byte that contains the type and reserved field.

Notes

Initiating a serial EEPROM read or write operation when the BUSY bit is set produces undefined results. SMBus errors may occur when accessing the serial EEPROM. If an error occurs, then it is reported in the SMBus Status (SMBUSSTS) register. Software should check for errors before and after each serial EEPROM access.

I/O Expanders

The PES3T3 utilizes external SMBus/I²C-bus I/O expanders connected to the master SMBus interface for hot-plug and port status signals. The PES3T3 is designed to work with Phillips PCA9555 compatible I/O expanders (i.e., PCA9555, PCA9535, and PCA9539). See the Phillips PCA9555 data sheet for details on the operation of this device.

An external SMBus I/O expander provides 16 bit I/O pins that may be configured as inputs or outputs. The PES3T3 supports up to four external I/O expanders. Table 6.3 summarizes the allocation of functions to I/O expanders. I/O expanders zero and one are used to provide hot-plug I/O signals while I/O expander four is used to provide link status and activity LED control. I/O expander signals associated with LED control (i.e., link status and activity) are active low (i.e., driven low when an LED should be turned on). I/O expander signals associated with hot-plug signals are not inverted.

SMBus I/O Expander	Section	Function
0	Lower	Port 2 hot-plug
	Upper	
1	Lower	Port 3 hot-plug
	Upper	
2	Lower	
	Upper	Power good inputs
4	Lower	Link status
	Upper	Link activity

Table 6.3 I/O Expander Function Allocation

During the PES3T3 initialization the SMBus/I²C-bus address allocated to each I/O expander used in that system configuration should be written to the corresponding IO Expander Address (IOE[0:5]ADDR) field. The IOE[0:3]ADDR fields are contained in the I/O Expander Address 0 (IOEXPADDR0) register while the IOE[4:5]ADDR fields are contained in the SMBus I/O Expander Address 1 (IOEXPADDR1) register.

Hot-plug outputs and I/O expanders may be initialized via serial EEPROM. Since the I/O expanders and serial EEPROM both utilize the master SMBus, no I/O expander transactions are initiated until serial EEPROM initialization completes.

- Since no I/O expander transactions are initiated until serial EEPROM initialization completes, it is not possible to toggle a hot-plug output through serial EEPROM initialization (i.e., it is not possible to cause a 0 -> 1 -> 0 transition or a 1 -> 0 -> 1 transition).

Whenever the value of an IOEXPADDR field is written, SMBus write transactions are issued to the corresponding I/O expander by the PES3T3 to configure the device. This configuration initializes the direction of each I/O expander signal and sets outputs to their default value. Outputs for ports that are disabled or are not implemented in that configuration are set to their negated value (e.g., the power indicator is turned off, the link is down, there is no activity, etc.).

The default value of I/O expander outputs is shown in Table 6.4. Note that this default value may be modified via serial EEPROM or SMBus configuration prior to SMBus initialization by changing the state of the PCI Express Slot Control Register (PCIESCTL) or Hot-Plug Configuration Control (HPCFGCTL).

Notes

SMBus I/O Expander Bit	Signal	Description	Default Value
(I/O-x.4)	P2AIN	Attention indicator output (off)	1
(I/O-x.5)	P2PIN	Power indicator output (on)	0
(I/O-x.6)	P2PEP	Power enable output (on)	1
(I/O-x.7)	P2ILOCKP	Electromechanical interlock (negated - off)	0

Table 6.4 I/O Expander Default Output Signal Value

The following I/O expander configuration sequence is issued by the PES3T3 to I/O expanders zero and one (i.e., the ones that contain hot-plug signals).

- Write the default value of the outputs bits on the lower eight I/O expander pins (i.e., I/O-0.0 through I/O-0.7) to I/O expander register 2.
- Write the default value of the outputs bits on the upper eight I/O expander pins (i.e., I/O-1.0 through I/O-1.7) to I/O expander register 3.
- Write value 0x0 to I/O expander register 4 (no inversion in IO-0)
- Write value 0x0 to I/O expander register 5 (no inversion in IO-1)
- Write the configuration value to select inputs/outputs in the lower eight I/O expander bits (i.e., I/O-0.0 through I/O-0.7) to I/O expander register 6.
- Write the configuration value to select inputs/outputs in the upper eight I/O expander bits (i.e., I/O-1.0 through I/O-1.7) to I/O expander register 7.
- Read value of I/O expander register 0 to obtain the current state of the lower eight I/O expander bits (i.e., I/O-0.0 through I/O-0.7)
- Read value of I/O expander register 1 to obtain the current state of the upper eight I/O expander bits (i.e., I/O-1.0 through I/O-1.7)

The following I/O expander configuration sequence is issued by the PES3T3 to I/O two (i.e., the one that contain power good inputs).

- Write the default value of the outputs bits on the lower eight I/O expander pins (i.e., I/O-0.0 through I/O-0.7) to I/O expander register 2.
- Write value 0x0 to I/O expander register 4 (no inversion in IO-0)
- Write value 0x0 to I/O expander register 5 (no inversion in IO-1)
- Write the configuration value to select inputs/outputs in the lower eight I/O expander bits (i.e., I/O-0.0 through I/O-0.7) to I/O expander register 6.
- Write the configuration value to select all inputs upper eight I/O expander bits (i.e., I/O-1.0 through I/O-1.7) to I/O expander register 7.
- Read value of I/O expander register 0 to obtain the current state of the lower eight I/O expander bits (i.e., I/O-0.0 through I/O-0.7)
- Read value of I/O expander register 1 to obtain the current state of the upper eight I/O expander bits (i.e., I/O-1.0 through I/O-1.7)

Notes

The following I/O expander configuration sequence is issued by the PES3T3 to I/O expander four (i.e., the one that contains link up and link activity status).

- Write link up status for all ports to the lower eight I/O expander pins (i.e., I/O-0.0 through I/O-0.7) to I/O expander register 2.
- Write link activity status for all ports to the upper eight I/O expander pins (i.e., I/O-1.0 through I/O-1.7) to I/O expander register 3.
- Write value 0x0 to I/O expander register 4 (no inversion in IO-0)
- Write value 0x0 to I/O expander register 5 (no inversion in IO-1)
- Write the configuration value to select all outputs in the lower eight I/O expander bits (i.e., I/O-0.0 through I/O-0.7) to I/O expander register 6.
- Write the configuration value to select all outputs in the upper eight I/O expander bits (i.e., I/O-1.0 through I/O-1.7) to I/O expander register 7.

While the I/O expander is enabled, the PES3T3 maintains the I/O bus expander signals and the PES3T3 internal view of the hot-plug signals in a consistent state. This means that whenever that I/O bus expander state and the PES3T3 internal view of the signal state differs, an SMBus transaction is initiated by the PES3T3 to resolve the state conflict.

- An example of an event that may lead to a state conflict is a hot reset. When a hot reset occurs, one or more hot-plug register control fields may be re-initialized to its default value. When this occurs, the internal PES3T3 state of the hot-plug signals is in conflict with the state of I/O expander hot-plug output signals. In such a situation, the PES3T3 will initiate an SMBus transaction to modify the state of the I/O expander hot-plug outputs.

Each I/O expander has an open drain interrupt output that is asserted when a pin configured as an input changes state from the value previously read. Each interrupt output from an I/O expander should be connected to the corresponding PES3T3 I/O expander interrupt input. Since the PES3T3 I/O expander interrupt inputs are GPIO alternate functions, the corresponding GPIOs should be initialized during configuration to operate in alternate function mode.

Note: In the PES3T3, the I/O expander interrupt input is mapped on the GPIO[2] alternate function, e.g., bit[2] of the GPIOFUNC register must be set to 0b1. Also, bits[4:3] of the GPIOFUNC must be set to 0b11.

Whenever the PES3T3 needs to change the state of an I/O expander signal output, a master SMBus transaction is initiated to update the state of the I/O expander. This write operation causes the corresponding I/O expander to change the state of its output(s). The PES3T3 will not update the state of an I/O expander output more frequently than once every 40 milliseconds. This 40 millisecond time interval is referred to as the I/O expander update period.

Whenever an input to the I/O expander changes state from the value previously read, the interrupt output of the I/O expander is asserted. This causes the PES3T3 to issue a master SMBus transaction to read the updated state of the I/O expander inputs. Regardless of the state of the interrupt output of the I/O expander, the PES3T3 will not issue a master SMBus transaction to read the updated state of the I/O expander inputs more frequently than once every 40 milliseconds (i.e., the I/O expander update period). This delay in sampling may be used to eliminate external debounce circuitry.

The I/O expander interrupt request output is negated whenever the input values are read or when the input pin changes state back to the value previously read. The PES3T3 ensures that I/O expander transactions are initiated on the master SMBus in a fair manner. This guarantees that all I/O expanders have equal service latencies. Any errors detected during I/O expander SMBus read or write transactions is reflected in the status bits of the SMBus Status (SMBUSSTS) register.

The I/O Expander Interface (IOEXPINTF) register allows direct testing and debugging of the I/O expander functionality. The Select (SEL) field in the IOEXPINTF register selects the I/O expander number on which other fields in the register operate. The I/O Expander Data field in the IOEXPINTF register reflect the current state, as viewed by the PES3T3, of the I/O expander inputs and outputs selected by the SEL field.

Notes

Writing a one to the Reload I/O Expander Signals (RELOADIOEX) bit in the IOEXPINTF register causes the PES3T3 to generate SMBus write and read transactions to the I/O expander number selected in the SEL field. This results in the value of the IOEDATA field being updated to reflect the current state of the corresponding I/O expander signals. This feature may be used to aid in debugging I/O expander operation. For example, a user who neglects to configure a GPIO as an alternate function may use this feature to determine that master SMBus transactions to the I/O expander function properly and that the issue is with the interrupt logic.

The IO Expander Test Mode (IOEXTM) bit in the IOEXPTINF register allows an I/O expander test mode to be entered. When this bit is set, the PES3T3 core logic outputs are ignored and the values written to the I/O expander for output bits are the values in the IOEDATA field. In this mode, the PES3T3 issues a transaction to update the state of the I/O expander whenever a bit corresponding to an I/O expander output changes state due to a write to the IOEDATA field. Bits in the IOEDATA field that correspond to outputs are dependent on the I/O expander number selected in the SEL field in the IOEXPINTF register. The outputs for each I/O expander number are shown in Table 6.5 through 6.8.

System design recommendations:

- I/O expander addresses and default output values may be configured during serial EEPROM initialization. If I/O expander addresses are configured via the serial EEPROM, the PES3T3 will initialize the I/O expanders when normal device operation begins following the completion of the fundamental reset sequence.
- If the I/O expanders are initialized via serial EEPROM, the data value for output signals during the SMBus initialization sequence will correspond to those at the time the SMBus transactions are initiated. It is not possible to toggle SMBus I/O expander outputs by modifying data values during serial EEPROM initialization.
- During a fundamental reset and before the I/O expander outputs are initialized, all I/O expander output signals default to inputs. Therefore, pull-up or pull-down resistors should be placed on outputs to ensure that they are held in the desired state during this period.
- All hot-plug data value modifications that correspond to hot-plug outputs result in SMBus transactions. This includes modifications due to upstream secondary bus resets and hot-resets.
- I/O expander outputs are not modified when the device transitions from normal operation to a fundamental reset. In systems where I/O expander output values must be reset during a fundamental reset, a PCA9539 I/O expander should be used.

I/O Expander 0

SMBus I/O Expander Bit	Type	Signal	Description
0 (I/O-0.0) ¹	I	P2APN	Port 2 attention push button input
1 (I/O-0.1)	I	P2PDN	Port 2 presence detect input
2 (I/O-0.2)	I	P2PFN	Port 2 power fault input
3 (I/O-0.3)	I	P2MRLN	Port 2 manually-operated retention latch (MRL) input
4 (I/O-0.4)	O	P2AIN	Port 2 attention indicator output
5 (I/O-0.5)	O	P2PIN	Port 2 power indicator output
6 (I/O-0.6)	O	P2PEP	Port 2 power enable output
7 (I/O-0.7)	O	P2ILOCKP	Port 2 electromechanical interlock
8 (I/O-1.0)	I	Reserved	
9 (I/O-1.1)	I	Reserved	

Table 6.5 I/O Expander 0 Signals (Part 1 of 2)

Notes

SMBus I/O Expander Bit	Type	Signal	Description
10 (I/O-1.2)	I	Reserved	
11 (I/O-1.3)	I	Reserved	
12 (I/O-1.4)	O	Reserved	
13 (I/O-1.5)	O	Reserved	
14 (I/O-1.6)	O	Reserved	
15 (I/O-1.7)	O	Reserved	

Table 6.5 I/O Expander 0 Signals (Part 2 of 2)

¹ I/O-x.y corresponds to the notation used for PCA9555 port x I/O pin y.

I/O Expander 1

SMBus I/O Expander Bit	Type	Signal	Description
0 (I/O-0.0) ¹	I	P3APN	Port 3 attention push button input
1 (I/O-0.1)	I	P3PDN	Port 3 presence detect input
2 (I/O-0.2)	I	P3PFN	Port 3 power fault input
3 (I/O-0.3)	I	P3MRLN	Port 3 manually-operated retention latch (MRL) input
4 (I/O-0.4)	O	P3AIN	Port 3 attention indicator output
5 (I/O-0.5)	O	P3PIN	Port 3 power indicator output
6 (I/O-0.6)	O	P3PEP	Port 3 power enable output
7 (I/O-0.7)	O	P3ILOCKP	Port 3 electromechanical interlock
8 (I/O-1.0)	I	Reserved	
9 (I/O-1.1)	I	Reserved	
10 (I/O-1.2)	I	Reserved	
11 (I/O-1.3)	I	Reserved	
12 (I/O-1.4)	O	Reserved	
13 (I/O-1.5)	O	Reserved	
14 (I/O-1.6)	O	Reserved	
15 (I/O-1.7)	O	Reserved	

Table 6.6 I/O Expander 1 Signals

¹ I/O-x.y corresponds to the notation used for PCA9555 port x I/O pin y.

Notes

I/O Expander 2

SMBus I/O Expander Bit	Type	Signal	Description
0 (I/O-0.0) ¹	I	Reserved	Tie High
1 (I/O-0.1)	I	Reserved	Tie High
2 (I/O-0.2)	I	Reserved	Tie High
3 (I/O-0.3)	I	Reserved	Tie High
4 (I/O-0.4)	O	Reserved	Tie High or Low
5 (I/O-0.5)	O	Reserved	Tie High or Low
6 (I/O-0.6)	O	Reserved	Tie High or Low
7 (I/O-0.7)	O	Reserved	Tie High or Low
8 (I/O-1.0)	I	Reserved	Tie High
9 (I/O-1.1)	I	Reserved	Tie High
10 (I/O-1.2)	I	P2PWRGDN	Port 2 power good input
11 (I/O-1.3)	I	P3PWRGDN	Port 3 power good input
12 (I/O-1.4)	I	Reserved	Tie High
13 (I/O-1.5)	I	Reserved	Tie High
14 (I/O-1.6)	O	Reserved	Tie High or Low
15 (I/O-1.7)	O	Reserved	Tie High or Low

Table 6.7 I/O Expander 2 Signals

¹: I/O-x.y corresponds to the notation used for PCA9555 port x I/O pin y.

I/O Expander 4

SMBus I/O Expander Bit	Type	Signal	Description
0 (I/O-0.0) ¹	O	P0LINKUPN	Port 0 link up status output
1 (I/O-0.1)	O	Reserved	Tie High or Low
2 (I/O-0.2)	O	P2LINKUPN	Port 2 link up status output
3 (I/O-0.3)	O	P3LINKUPN	Port 3 link up status output
4 (I/O-0.4)	O	Reserved	Tie High or Low
5 (I/O-0.5)	O	Reserved	Tie High or Low
6 (I/O-0.6)	O	Reserved	Tie High or Low
7 (I/O-0.7)	O	Reserved	Tie High or Low
8 (I/O-1.0)	O	P0ACTIVEN	Port 0 activity output
9 (I/O-1.1)	O	Reserved	Tie High or Low
10 (I/O-1.2)	O	P2ACTIVEN	Port 2 activity output
11 (I/O-1.3)	O	P3ACTIVEN	Port 3 activity output

Table 6.8 I/O Expander 4 Signals (Part 1 of 2)

Notes

SMBus I/O Expander Bit	Type	Signal	Description
12 (I/O-1.4)	0	Reserved	Tie High or Low
13 (I/O-1.5)	0	Reserved	Tie High or Low
14 (I/O-1.6)	0	Reserved	Tie High or Low
15 (I/O-1.7)	0	Reserved	Tie High or Low

Table 6.8 I/O Expander 4 Signals (Part 2 of 2)

¹: I/O-x.y corresponds to the notation used for PCA9555 port x I/O pin y.

Notes



Power Management

Notes

Introduction

The PES3T3 supports the following device power management states: D0 Uninitialized, D0 Active, D3_{Hot}, and D3_{Cold}. A power management state transition diagram for the states supported by the PES3T3 is provided in Figure 7.1 and described in Table 7.1.

A power management capability structure is located in the configuration space of each PCI-PCI bridge in the PES3T3. The power management capability structure associated with a PCI-PCI bridge of a downstream port only affects that port. Entering the D3_{Hot} state allows the link associated with the bridge to enter the L1 state. The power management capability structure associated with the upstream port (i.e., port 0) affects the entire device. The PES3T3 supports the link Wakeup mechanism. It supports both in-band Beacon signaling (transmission only, not detection) and side band WAKEN signaling. The Wakeup Protocol requires the Vaux power supply to be ON.

The functional context is maintained in the D3_{Hot} state if the No_Soft_Reset (NOSOFTTRST) bit in the Power Management Control and Status Register (PMCSR) is set to 1. The internal logic and the contents of the registers are maintained and the software is not required to re-initialize the device on transitions from D3_{Hot} to D0. Thus, the default value of the NOSOFTTRST bit in the PMCSR register corresponds to the functional context being maintained in the D3_{Hot} state. However, the device is reset if the link enters L2/L3 Ready state regardless of the NOSOFTTRST bit settings, and the software will have to re-initialize the device.

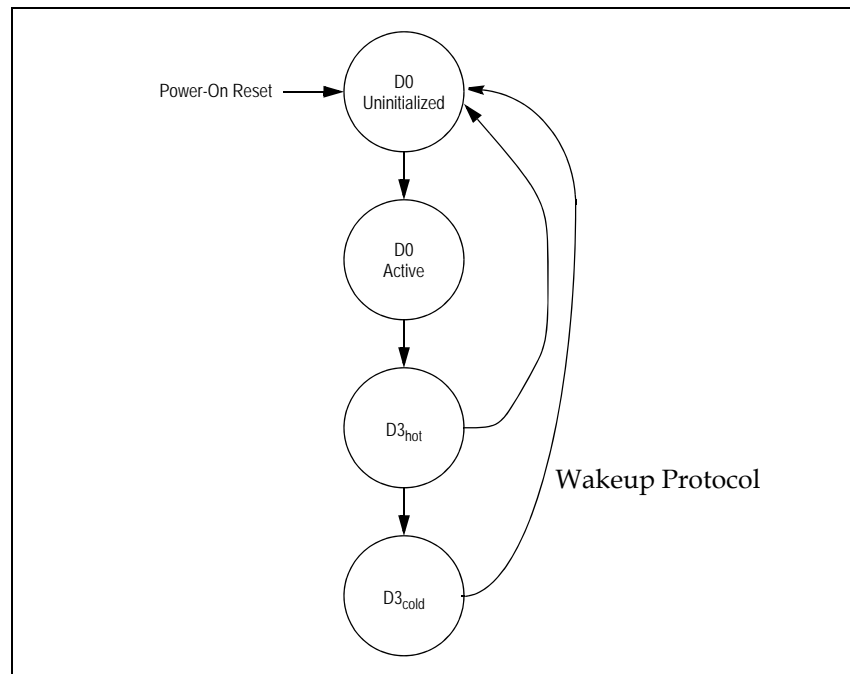

Figure 7.1 PES3T3 Power Management State Transition Diagram

Notes

From State	To State	Description
Any	D0 Uninitialized	Power-on fundamental reset.
D0 Uninitialized	D0 Active	PCI-PCI bridge configured by software.
D0 Active	D3 _{Hot}	The Power Management State (PMSTATE) field in the PCI Power Management Control and Status (PMCSR) register is written with the value that corresponds to the D3 _{Hot} state.
D3 _{Hot}	D0 Uninitialized	The Power Management State (PMSTATE) field in the PCI Power Management Control and Status (PMCSR) register is written with the value that corresponds to D0 state.
D3 _{Hot}	D3 _{Cold}	Power is removed from the device.
D3 _{Cold}	D0 Uninitialized	The device transitions to the D0 Uninitialized state when the system reinstalls device power and clock and applies a fundamental reset in response to the Wakeup Protocol. The Wakeup mechanism is powered by the Vaux power supply.

Table 7.1 PES3T3 Power Management State Transition Diagram

The PES3T3 PCI-to-PCI bridges (i.e., ports) have the following behavior when in the D3_{Hot} power management state.

- A bridge accepts, processes, and completes all type 0 configuration read and write requests.
- A bridge accepts and processes all message requests that target the bridge.
- All requests received by the bridge on the primary interface, except as noted above, are treated as unsupported requests (UR).
- Any error message resulting from the receipt of a TLP is reported in the same manner as when the bridge is not in the D3_{Hot} state (e.g., generation of an ERR_NONFATAL message to the root).
- Error messages resulting from any event other than the receipt of a TLP are discarded (i.e., no error message is generated).
- All completions that target the bridge are treated as unexpected completions (UC).
- Completions flowing in either direction through the bridge are routed as normal. This behavior of the bridge does not differ from that of the bridge when it is in the D0 power management state.
- All request TLPs received on the secondary interface are treated as unsupported requests (UR).

PME Messages

Downstream ports (i.e., PCI-PCI bridges associated with downstream ports) support the generation of hot-plug PME events (i.e., a PM_PME power management message) from the D3_{Hot} state. This includes both the case when the downstream port is in the D3_{Hot} state or the entire switch is in the D3_{Hot} state.

The generation of a PME message by downstream ports necessitates the implementation of a PME service time-out mechanism to ensure that PME messages are not lost. After a PM_PME message is transmitted, if the PME Status (PMES) bit in the downstream port's PCI Power Management Control and Status (PMCSR) register is not cleared within the time-out period specified in the PM_PME Time-Out (PMPMETO) field in the port's PM_PME Timer (PMPMETIMER) register, then the PM_PME message is retransmitted and the timer is restarted.

If the PES3T3 issues a hot plug PME message but the PME_Status is not cleared before the link enters a deep sleep state in response to PME_Turn_Off message, it reactivates the link using the wakeup mechanism (refer to section Wakeup Protocol on page 7-4).

Notes

Power Express Power Management Fence Protocol

The Root complex takes the following steps to turn off power to a system:

- The root places all devices in the D3_{Hot} state
- Upon entry to D3_{Hot}, all devices transition their links to the L1 state
- The root broadcasts a PME_Turn_Off message
- Devices acknowledge the PME_Turn_Off message by returning a PME_TO_ACK message.

When the PES3T3 receives a PME_Turn_Off message it broadcasts the PME_Turn_Off message on all active downstream ports. Prior to sending PME_TO_Ack response back, the upstream port starts aggregating PME_TO_Ack response from all the downstream ports. After it has received a PME_TO_Ack message on each of its downstream ports, the PES3T3 transmits a PME_TO_Ack message on its upstream port and transitions its upstream link to L2/L3 Ready state.

The aggregation of PME_TO_Ack messages on downstream ports is abandoned when the upstream port receives a TLP after receiving a PME_Turn_Off message on that port, but before it has responded with a PME_TO_Ack message. Once a PME_TO_Ack message has been scheduled for transmission on the upstream port, there is no need to abandon PME_TO_Ack aggregation, and received TLPs at that point may be discarded.

If the TLP that causes PME_TO_Ack aggregation to be abandoned targets the PES3T3, the PES3T3 responds to the TLP normally. If the TLP that causes aggregation to be abandoned targets a downstream port and the port is in L0, the TLP is transmitted on the downstream port. If the downstream port is not in L0 (i.e., it is in L2/L3 Ready), the switch transitions the link to Detect and then to L0. Once the link reaches L0, the TLP is transmitted on the downstream port.

When PME_TO_Ack aggregation is abandoned, the PES3T3 makes no attempt to abandon the PME_Turn_Off and PME_TO_Ack protocol on downstream ports. Devices downstream of the PES3T3 are allowed to respond with a PME_TO_Ack and to transition to L2/L3 Ready. When the PES3T3 receives a TLP (targeting switch or downstream devices) during the PME aggregation process, it waits for the arrival of PME_TO_Ack from all the downstream ports before initiating link retraining on all the downstream ports. The received TLP is sent to the destination port after the links retrain.

In order to avoid deadlock, a downstream port that does not receive a PME_TO_Ack message in the time-out period specified in the PME_TO_Ack Time-Out (PMETOATO) field in the PME_TO_Ack Timer (PMETOATIMER) register, declares a time-out, transitions its link to L2/L3 Ready state and signals to the upstream port that a PME_TO_Ack message has been received. Upon receiving a PME_Turn_Off message, the PES3T3 blocks the transmission of PM_PME messages. If instead of being transitioned to the D3_{Cold} state, the PES3T3 is transitioned to the D0_{uninitialized} state, then the PES3T3 resumes generation of PM_PME messages.

Power Budgeting Capability

The PES3T3 contains the mechanisms necessary to implement the PCI express power budgeting enhanced capability. However, by default, these mechanisms are not enabled. To enable the power budgeting capability, registers in this capability should be initialized and the Next Pointer (NXTPTR) field in one of the other enhanced capabilities should be initialized to point to the power budgeting capability. The Next Pointer (NXTPTR) of the power budgeting capability should be adjusted if necessary.

The power budgeting capability consists of the four power budgeting capability registers defined in the PCIe 1.0a base specification and eight general purpose read-write registers. See section Power Budgeting Enhanced Capability on page 9-49 for a description of these registers.

The Power Budgeting Capabilities (PWRBCAP) register contains the PCI express enhanced capability header for the power budgeting capability. By default, this register has an initial read-only value of zero. To enable the power budgeting capability, this register should be initialized via the serial EEPROM.

The Power Budgeting Data Value [0..9] (PWRBDV[0..9]) registers are used to hold the power budgeting information for that port in a particular operating condition. The PWRBDV registers may be read and written when the Power Budgeting Data Value Unlock (PWRBDVUL) bit is set in the Switch Control (SWCTL)

Notes

register. When the PWRBDVUL bit is cleared, these register are read-only and writes to these registers are ignored. To enable the power budgeting capability, the PWRBDV registers should be initialized with power budgeting information via the serial EEPROM.

WakeUp Protocol

The PES3T3 supports the PCIe link wakeup protocol when the following conditions are met:

- Auxiliary Power is turned on
- The PES3T3 is enabled for auxiliary power consumption
- PMEE bit in the Power Management Control and Status Register is set.

The PES3T3 supports both in-band Beacon signaling (transmission only) and the WAKEN side band signal to initiate or propagate the wakeup protocol.

- PES3T3 has the ability to initiate the wakeup protocol via assertion of the WAKEN signal or in-band beacon signal transmission.
- PES3T3 has the ability to translate and propagate the WAKEN input signal to in-band Beacon output signaling.
- PES3T3 does not support reception of the in-band Beacon signal.

The WAKEN signal mechanism and Beacon signal mechanism are enabled by default. Both of these mechanisms can be disabled by clearing the WAKEEN and BCONEN bits in wakeup protocol control (WAKEUPCNTL) register. The PES3T3 uses auxiliary voltage to power WAKEN and Beacon generation circuitry besides retaining PME context. The PME context comprises the contents of Power Management Status and control register.

The AUXPD bit in the PCI Express Device status (PCIEDSTS) register records the status of the auxiliary supply. If the auxiliary voltage is present, this bit is set, otherwise it is reset. Powering down of the PCIe hierarchy adheres to the following sequence of events:

- On receiving PME_Turn_Off message, Upstream port forwards the message to all the active downstream ports
- Upstream waits for PME_TO_Ack message from all the downstream ports.
- On receiving PME_TO_Ack messages from all the downstream ports, Upstream port sends PME_TO_Ack to the root complex. In case PME_TO_Ack is not received from downstream port within time period specified in PME_TO_Ack timer register, the upstream port proceeds ahead as if the PME_TO_Ack message has been received by all the downstream ports.
- The upstream port sends PM_Enter_L23 DLLP to the upstream component and waits for the acknowledgement. Also, the downstream ports acknowledge the PM_Enter_L23 DLLPs received from the downstream components.
- On receiving acknowledgement for the PM_Enter_L23 DLLP on the upstream port, the SerDes for the upstream port and downstream ports are turned off (i.e., the links are placed in L23-Ready state).

The PME_Status (PMES) bit in the PMCSR register is sticky and the PES3T3 maintains its value as part of the PME Context through reset. If this bit is set and is not cleared by software before the link prepares to enter non-communicating state in response to the receipt of PME_Turn_Off message, the PES3T3 initiates the wakeup protocol. Once the link is retrained and reactivated, the PES3T3 sends a PME message to the root complex.

The WAKEN signal can be used as input or an output. The direction of the WAKEN signal can be changed by programming the WAKEDIR bit in the Switch Control (SWCTL) register. The programmed direction of the WAKEN signal is maintained in D3cold state as long as auxiliary power supply is available and the wakeup protocol enabled.

Notes

WAKEN Signal as an Input

The WAKEN signal may be configured as an input to make use of the PES3T3's ability to translate WAKEN input to Beacon transmission (on the upstream link). To enable this feature, the following must be true:

- The WAKEDIR bit in the SWCTL register must be 0x0.
- The WAKEEN bit in the WAKEUP register is set.
- The BCONEN bit in the WAKEUP register is set.
- Auxiliary power is ON.
- Auxiliary power consumption is enabled (APWREN bit is set in the Switch Control register).
- The PMEE bit in the PMCSR register of the upstream port is set.

On receiving WAKEN signal, the PES3T3 propagates transmission of the in-band beacon signal on the upstream link until a break in electrical idle is detected in this link.

WAKEN Signal as an Output

The WAKEN signal may be configured as an output when it is desired that the PES3T3 initiate the wakeup protocol by asserting this signal. In order to enable the WAKEN signal as an output, the following must be true:

- The WAKEDIR bit in the SWCTL register must be 0x1.
- The WAKEEN bit in the WAKEUP register is set.
- Auxiliary power is ON
- Auxiliary power consumption is enabled (APWREN bit is set in Switch Control register)
- PMEE bit in the PMCSR register in the associated downstream port is set.

WAKEN and Beacon Disabled

When both the WAKEN and Beacon signalling mechanisms are disabled, the PES3T3 wakeup protocol mechanism is disabled.

Auxiliary Power Implementation

Switch System States

The PES3T3 system states are determined by the main power and auxiliary power supply ON/OFF state as shown in Figure 7.2.

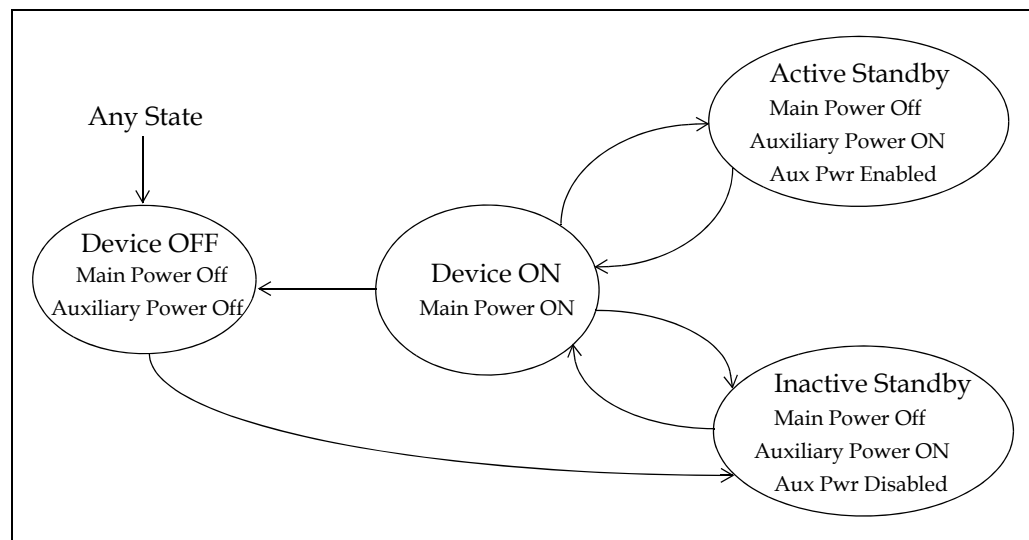

Figure 7.2 PES3T3 System States

Notes

In Device OFF state, both main power and the auxiliary power is off.

The device enters Inactive Standby when the auxiliary power is applied and Main Power is Off. When main power is applied the device enters the Device ON state. As shown in Figure 7.3, when main power is applied for the first time after auxiliary power is switched ON, the external POR circuitry is required to assert PERSTN and sequence the APWRDISN signal with respect to PERSTN . The internal logic utilizes this external POR driven sequence to build a capability to determine whether switch was in L2 state or not at the time of application of fundamental reset.

If the APWRDISN signal is low after 8 clock cycles from de-assertion of PERSTN then it implies that the device was not in L2 state when fundamental reset was applied. All the FRSticky bits are initialized in this case. If APWRDISN signal is high after 8 clock cycles from de-assertion of PERSTN then all the FRSticky bits are preserved.

The state of APWRDISN signal after 256 clocks of de-assertion of PERSTN is used to initialize the APWREN bit in the switch control register. If the signal is low, APWREN bit is '0' indicating that the L2 mode has been disabled. Otherwise, APWREN bit is set.

The PME Enable bit controls the ability of the device to raise PME events from D3cold state . Only devices that are enabled to generate PME events from D3cold are allowed to utilize auxiliary power supply.

The auxiliary power can be used only if the Auxiliary Power Detected (AUXPD) bit is set in the PCI Express Device Status register. The Auxiliary Power Enable bit (APWREN) in the Switch Control (SWCTL) register controls setting or resetting of this bit as described in section Auxiliary Power Control on page 7-6 . The L2 mode is enabled only when both AUXPD bit in PCIESTS and PMEE bit PMCSR register are set. If L2 mode is enabled and main power is removed, the switch enters Active Standby.

When the main power rail is switched OFF and auxiliary power rail is ON then the switch can enter Active or Inactive standby depending upon whether auxiliary power is enabled. If the auxiliary power is enabled then the switch enters Active standby and all the FRSticky register bits are saved along with powering ON of the internal Wake and Beacon sensing and generation logic. Otherwise, the device enters InActive standby and the FRSticky register bits are not saved. The internal Wake and Beacon logic is not powered ON in this state.

The normal configuration register fields (RW, RO, etc.) are set to the initial value as a result of any type of reset. The Sticky and RWL fields are preserved across hot and secondary bus resets. The FRSticky fields are preserved across all resets (hot, warm, cold). The FRSticky fields are reset when main power is applied for the first time after auxiliary power is turned ON as shown in Figure 7.3.

Auxiliary Power Control

The PES3T3 supports the Auxiliary Power Disable (APWRDISN) input pin that is used to enable/disable the Auxiliary Power Usage.

Notes

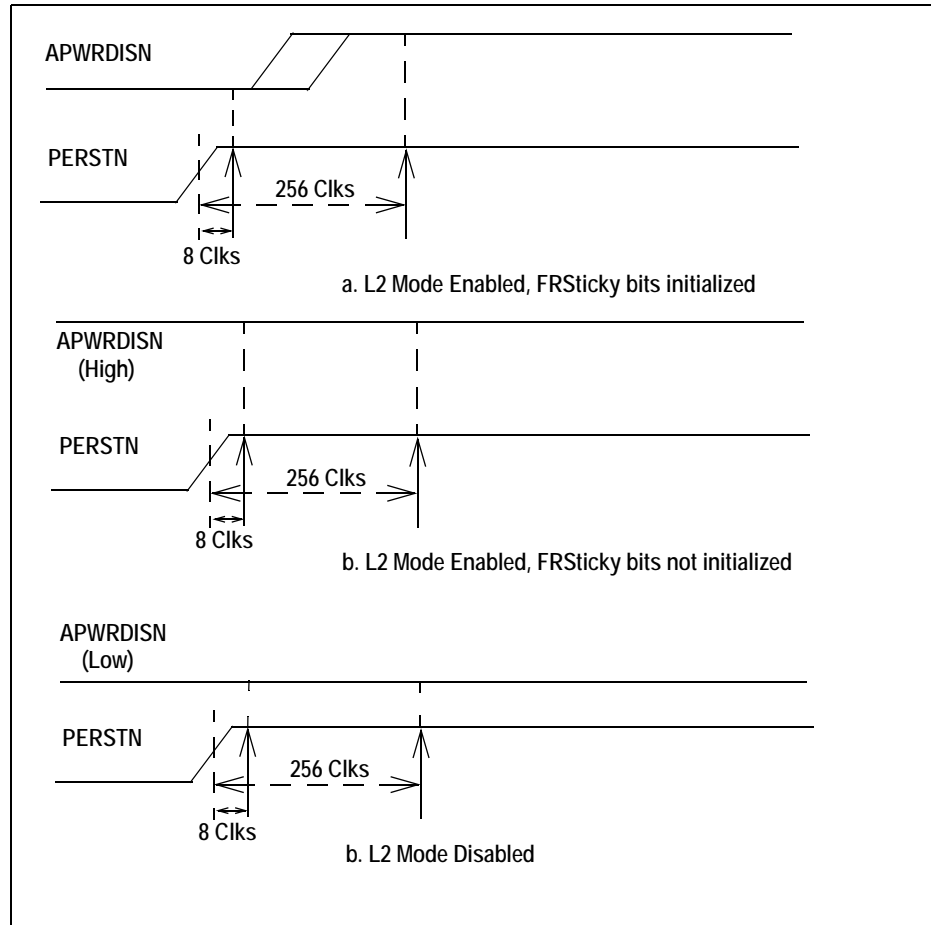

Figure 7.3 L2 Mode Enable/Disable and FRSticky Bit Initialization

If the APWRDISN signal is inactive (High) 256 clocks after de-assertion of the fundamental reset, the Auxiliary Power Enable (APWREN) bit is set in the SWCTL register. If the APWRDISN signal is active (Low) 256 clocks after de-assertion of the fundamental reset, the APWREN bit is reset and auxiliary power usage is disabled.

The AUXPD bit in the PCI Express Device Status register is set only when the APWREN bit in the Switch Control Register is set to '1'. Based on the supported auxiliary power usage model shown in Figure 7.5, the PES3T3 does not sense an auxiliary power presence on the power pin. The Auxiliary Power Usage could also be enabled, given that the PMEE bit is set in the PMCSR register, by setting the APWREN bit in the Switch Control once the system comes up. In order for proper transition to/from L2 mode, it is assumed that the software also correctly sets the state of APWRDISN when enabling the APWREN bit.

L2 Mode Enabled, FRSticky Bits Initialized

The corresponding signal sequence for this state transition is shown in Figure 7.3(a). The external POR circuitry initiates this sequence on APWRDISN when the main power is first switched ON after the auxiliary power is turned ON. The APWRDISN signal input is sampled 8 clock cycles after de-assertion of the fundamental reset (PERSTN). A low state of this signal triggers initialization of the FRSticky bits. The APWRDISN signal input is sampled again 256 clock cycles after de-assertion of the fundamental reset. A high state of this signal sets the APWREN bit in the SWCTL register.

L2 Mode Enabled, FRSticky Bits Not Initialized

This sequence is shown in Figure 7.3(ba). The external POR circuitry maintains the APWRDISN signal high after main power is first turned ON. The APWRDISN signal input is sampled 8 clock cycles after de-assertion of the fundamental reset (main power is turned OFF to save power when the hierarchy is idle and

Notes

turned ON using in-band beacon or out-of-band WAKEN signaling when the traffic resumes). The signal is sampled High, resulting in retention of the state of the FRSticky bits. The APWRDISN signal input is sampled again 256 clock cycles after de-assertion of the fundamental reset (PERSTN). A high state of this signal continues to set the APWREN bit in the SWCTL register.

L2 Mode Disabled

This sequence is shown in Figure 7.3(c). The external POR circuitry ties the APWRDISN signal low. The APWRDISN signal input is sampled 8 clock cycles after de-assertion of the fundamental reset (PERSTN). A Low state of this signal results in initialization of the FRSticky bits. The APWRDISN signal input is sampled again 256 clock cycles after de-assertion of the fundamental reset (PERSTN). A Low state of this signal resets the APWREN bit in the SWCTL register, thereby disabling L2 mode.

PES3T3 Auxiliary Power Usage

The AUXPD bit in the PCI Express Device Status register is set only when Auxiliary Power Usage is enabled by either de-asserting the Auxiliary Power Disable active low signal at bring-up time or by setting the APWREN bit in the Switch Control register. Based on the supported Auxiliary Power Usage model shown in Figure 7.4, the PES3T3 does not sense an auxiliary power presence on the power pin.

All the core logic in the PES3T3 is powered from a common supply. The auxiliary power is used to power I/Os that are ON during active standby.

- VA3P3 (3.3V) powers I/Os that are ON during active standby
- VA1P0 (1.0 V)
 - Powers RAMBus SerDes Macros
 - Powers V_{TTPE}
 - Powers Core logic that operates during active standby.

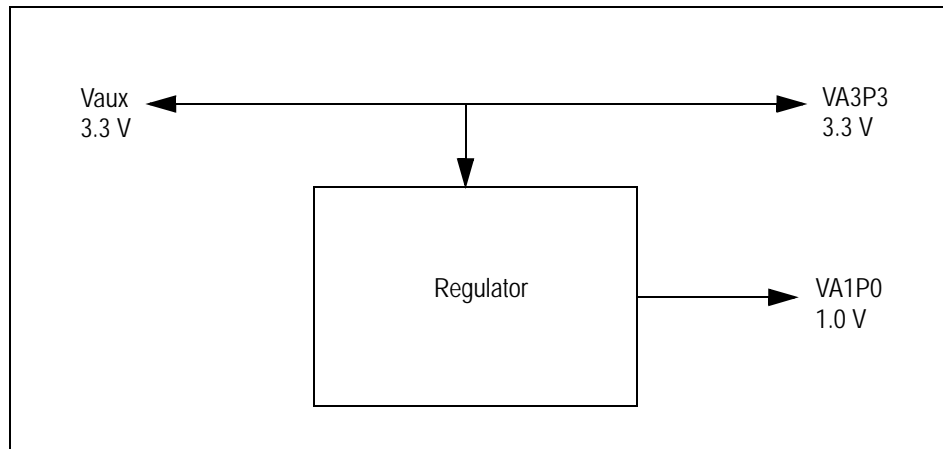

Figure 7.4 Vaux Usage Model

The auxiliary power supply current budget numbers are given in Tables 7.2 and 7.3.

Notes

Item	Current Estimate (mA)	Comment
3.3 V _{DDIO} Power Supply	6	In L2 mode, auxiliary power supply is used to power up all the I/Os.
Rambus L2 (2 SerDes quads ON with Beacon OFF in both the SerDes)	110	
Core Logic	14	
3.3 V I/O	6	
Regulator Leakage	tbd	
Total Current	tbd	

Table 7.2 Auxiliary Power Enabled (Beacon OFF)

Item	Current Estimate (mA)	Comment
3.3 V _{DDIO} Power Supply	6	In L2 mode, auxiliary power supply is used to power up all the I/Os.
Rambus L2 (both-SerDes OFF)	4	
Core Logic	14	
3.3 V I/O	6	
Regulator Leakage	tbd	
Total Current	tbd	

Table 7.3 Auxiliary Power Enabled (SerDes OFF, only WAKEN Enabled)

In Active standby, the clock is gated. When the main power is switched off, the auxiliary power supply is used to power the SerDes (for Beacon sensing and generation), provide V_{TTPE} supply and power core logic that is operational during Active standby. This is illustrated in Figure 7.5.

Notes

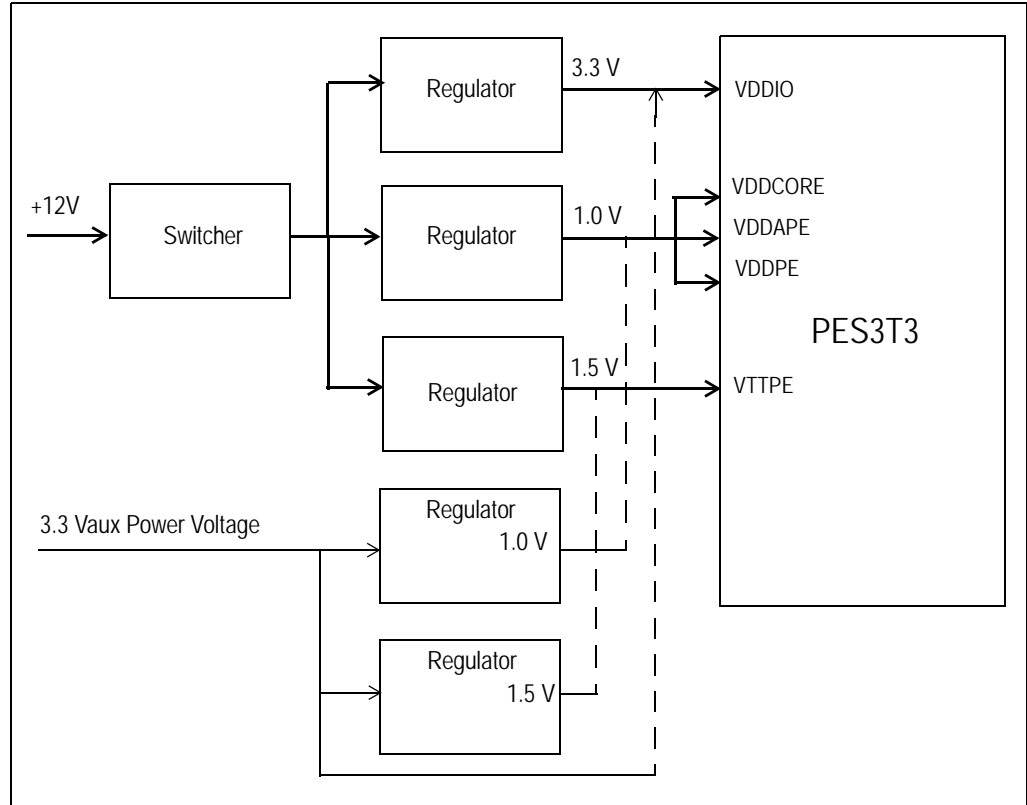

Figure 7.5 Conceptual Diagram of the PES3T3 Auxiliary Power Connection

When the device enters the Active standby mode, the auxiliary voltage powers the V_{DDCORE} , V_{DDAPE} , V_{DDPE} , V_{DDIO} , and V_{TTPE} supplies to the PES3T3.



Hot-Plug and Hot-Swap

Notes

Introduction

As illustrated in Figures 8.1 through 8.3, a PCIe switch may be used in one of three hot-plug configurations. Figure 8.1 illustrates the use of the PES3T3 in an application in which two downstream ports are connected to slots into which add-in cards may be hot-plugged. Figure 8.2 illustrates the use of the PES3T3 in an add-in card application. Here the downstream ports are hardwired to devices on the add-in card and the upstream port serves as the add-in card's PCIe interface. In this application the upstream port may be hot-plugged into a slot on the main system. Finally, Figure 8.3 illustrates the use of the PES3T3 in a carrier card application. In this application, the downstream ports are connected to slots which may be hot-plugged and the entire assembly may be hot-plugged into a slot on the main system. Since this application requires nothing more than the functionality illustrated in both Figures 8.1 through 8.2, it will not be discussed further.

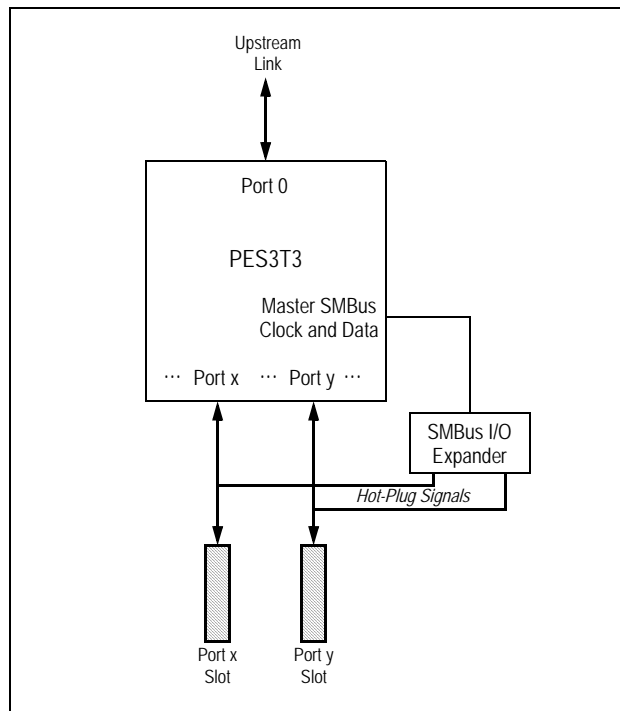

Figure 8.1 Hot-Plug on Switch Downstream Slots Application

Notes

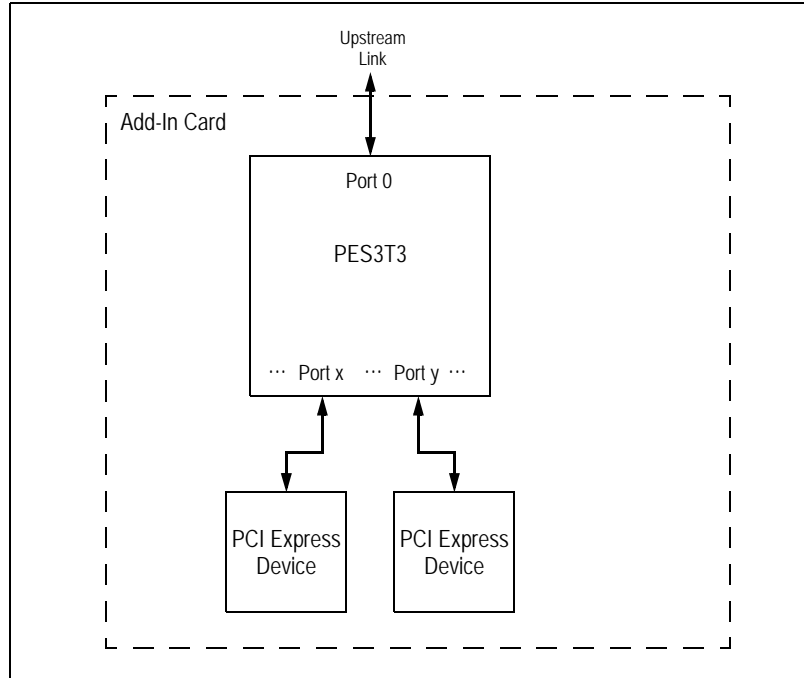

Figure 8.2 Hot-Plug with Switch on Add-In Card Application

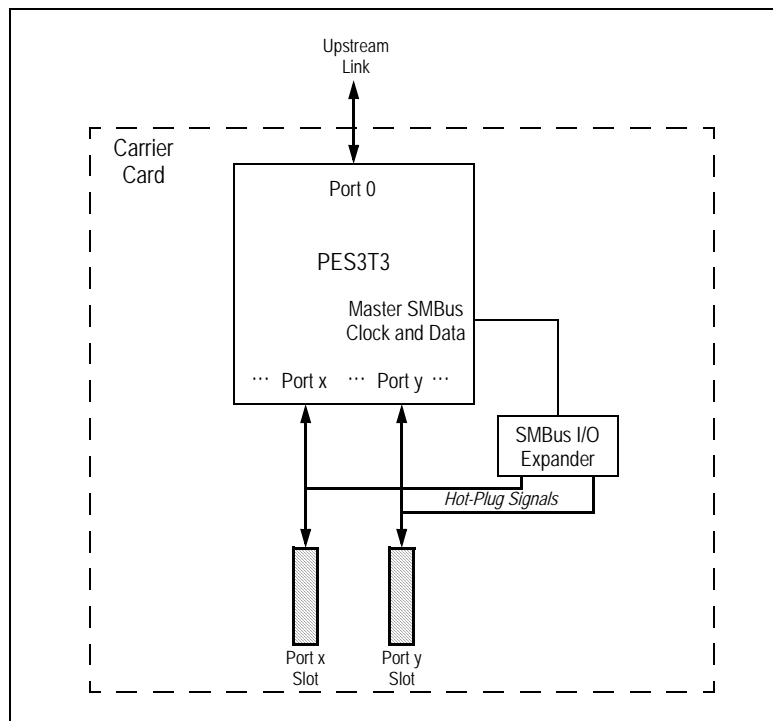

Figure 8.3 Hot-Plug with Carrier Card Application

The PCI Express Base Specification revision 1.0a allowed a hot-plug attention indicator, power indicator, and attention button to be located on the board on which the slot is implemented or on the add-in board. When located on the add-in board, state changes are communicated between the hot-plug controller associated with the slot and the add-in card via hot-plug messages. This capability was removed in revision 1.1 of the PCI Express Base Specification and is not supported in the PES3T3.

Notes

The remainder of this section discusses the use of the PES3T3 in an application in which one or both of the downstream ports are used in an application in which an add-in card may be hot-plugged into a downstream slot. Associated with each downstream port in the PES3T3 is a hot-plug controller. The hot-plug controller may be enabled by setting the HPC bit in the PCI Express Slot Capabilities (PCIESCAP) register associated with that port during configuration (e.g., via serial EEPROM).

The PES3T3 allows sensor inputs and indicator outputs to be located next to the slot or on the plug in module. Regardless of the physical location, the indicators are controlled by the PES3T3's downstream port. Table 8.1 lists the hot-plug inputs and outputs that may be associated with a slot. When enabled during configuration in the PCIESCAP register, these inputs and outputs are made available to external logic using an external I/O expander located on the master SMBus interface.

The PES3T3 supports both presence detect signalling via a pin assertion as well as in-band presence detect. The PDETECT field in Hot Plug Configuration control register and RDETECT field in the PHY Link Configuration register¹ is used to enable presence detect options.

Signal	Type	Name/Description
PxAPN	I	Port x ¹ Attention Push button Input.
PxPDN	I	Port x Presence Detect Input.
PxPFN	I	Port x Power Fault Input.
PxMRLN	I	Port x Manually-operated Retention Latch (MRL) Input.
PxAIn	O	Port x Attention Indicator Output.
PxPIN	O	Port x Power Indicator Output.
PxPEP	O	Port x Power Enable Output.
PxILOCKP	O	Port x Electromechanical Interlock.
PxPWRGDN	I	Port x Power Good Input (asserted when slot power is good).
PxRSTN ²	O	Port x Reset Output.

Table 8.1 Downstream Port Hot Plug Signals

¹ x corresponds to downstream port number (i.e., 2 or 3).

² This signal is a GPIO pin alternate function and is not available as an I/O expander output.

Since the polarity of hot-plug signals has been defined differently in various specifications, each hot plug signal has a corresponding control bit in the Hot-Plug Configuration Control (HPCFGCTL) that allows the polarity of that signal to be inverted. Inversion affects the corresponding signal in all ports.

When a one is written to the EIC bit in the PCIESCTL register, the PxILOCKP signal is pulsed for with a pulse length greater than 100 ms and less than 150 ms (i.e., it transitions from negated to asserted, maintains an asserted state for 100 to 150 ms, and then transitions back to negated). When the Toggle Electromechanical Interlock Control (TEMICCTL) bit in the HPCFGCTL register is set, writing a one to the EIC bit inverts the state of the PxILOCKP signal.

When the Replace MRL Status with EMIL Status (RMRLWEMIL) bit is set in the HPCFGCTL register, then the port's PxMRLN input is used as the electromechanical state input. The state of this input is used as the state of the electromechanical interlock state obtained by reading the Electromechanical Interlock Status (EIS) bit in the PCI Express Slot Status (PCIESSTS) register. In this mode, the state of the Manually-operated Retention Latch Sensor State (MRLSS) status is always reported as closed (i.e., zero). When the RMRLWEMIL bit is cleared, the EIS bit state in the PCIESSTS register always returns the value of corresponding PxILOCKP I/O expander signal output.

¹ Note: For further information on this register, please contact ssdhelp@idt.com.

Notes

When the MRL Automatic Power Off (MRLPWROFF) bit is set in the HPCFGCTL register and the Manual Retention Latch Present (MRLP) bit is set in the PCI Express Slot Capability (PCIESCAP) register, then power to the slot is automatically turned off when the MRL sensor indicates that the MRL is open. This occurs regardless of the state of the Power Controller Control (PCC) bit in the PCI Express Slot Control (PCIESCTL) register. The state of a port's Power Fault (PxPFN) input is not latched by the PES3T3. For proper operation, the system designer should ensure that once the PxPFN signal is asserted, it remains asserted until the power enable (PxPEP) signal is toggled. This is required adapter behavior for the PCI Express ExpressModule form factor.

Downstream port reset outputs are described in section Downstream Port Reset Outputs on page 2-8. The default value of hot-plug registers following a hot or fundamental reset may be configured via serial EEPROM initialization. Since hot-plug I/O expander initialization occurs after serial EEPROM initialization, the Command Completed (CC) bit is not set in the PCI Express Slot Status (PCIESSTS) register as a result of serial EEPROM initialization.

Hot-Plug I/O Expander

The PES3T3 utilizes external SMBus/I2C-bus I/O expanders connected to the master SMBus interface for hot-plug related signals associated with downstream ports. See section I/O Expanders on page 6-5 for details on the operation of the I/O expanders and for the mapping of downstream hot-plug signals to I/O expander inputs and outputs.

Hot-Plug Interrupts and Wake-up

The hot-plug controller associated with a downstream slot may generate an interrupt or wakeup event. Hot-plug interrupts are only generated when the Hot Plug Interrupt Enable (HPIE) bit is set in the corresponding port's PCI Express Slot Control (PCIESCTL) register.

The following bits, when set in the PCI Express Slot Status (PCIESSTS) register, generate an interrupt if not masked by the corresponding bit in the PCI Express Slot Control (PCIESCTL) register or by the HPIE bit: the Attention Button Pressed (ABP), Power Fault Detected (PFD), MRL Sensor Changed (MRLSC), Presence Detected Changed (PDC), and Command Completed (CC).

When an unmasked hot-plug interrupt is generated, the action taken is determined by the MSI Enable (EN) bit in the MSI Capability (MSICAP) register and the Interrupt Disable (INTXD) bit in the PCI Command (PICCMD) register. When the downstream port or the entire switch is in a D3_{Hot} state, the hot-plug controller generates a wakeup event using a PM_PME message instead of an interrupt if the event interrupt is not masked in the slot control (PCIESCTL) register and hot-plug interrupts are disabled by the HPIE bit. If the event interrupt is not masked and hot-plug interrupts are enabled, both a PM_PME and an interrupt are generated. If the event interrupt is masked, neither a PM_PME nor interrupt are generated. Note that a command completed (CC bit) interrupt will not generate a wakeup event.

Legacy System Hot-Plug Support

Some systems require support for operating systems that lack PCIe hot-plug support. The PES3T3 supports these systems by providing a General Purpose Event (GPEN) output as an alternate function of GPIO[7] that can be used instead of the INTx, MSI, and PME mechanisms defined by PCI Express hot-plug. Associated with each downstream port's hot-plug controller is a bit in the General Purpose Event Control (P0_GPECTL) register. When this bit is set, then the corresponding PCIe base 1.1 hot-plug event notification mechanisms are disabled for that port and INTx, MSI and PME events will not be generated by that port due to hot-plug events. Instead, hot-plug events are signaled through assertion of the GPEN signal. GPEN is an alternate function of GPIO[7], and GPIO[7] will not be asserted when GPEN is asserted unless it is configured to operate as an alternate function.

Whenever a port signals a hot-plug event through assertion of the GPEN signal, the corresponding port's status bit in the General Purpose Event Status (P0_GPESTS) register is set. A bit in the P0_GPESTS register can only be set if the corresponding port's hot-plug controller is configured to signal hot-plug events using the general purpose event (GPEN) signal assertion mechanism.

Notes

The hot-plug event signalling mechanism is the only thing that is affected when a port is configured to use general purpose events instead of the PCIe defined hot-plug signalling mechanisms (i.e., INTx, MSI and PME). Thus, the PCIe defined capability, status and mask bits defined in the PCIe slot capabilities, status and control registers operate as normal and all other hot-plug functionality associated with the port remains unchanged. INTx, MSI and PME events from other sources are also unaffected.

The enhanced hot-plug signalling mechanism supported by the PES3T3 is graphically illustrated in Figure 8.4. This figure provides a conceptual summary of the enhanced hot-plug signalling mechanism in the form of a pseudo logic diagram. Logic gates in this diagram are intended for conveying general concepts, and not for direct implementation.

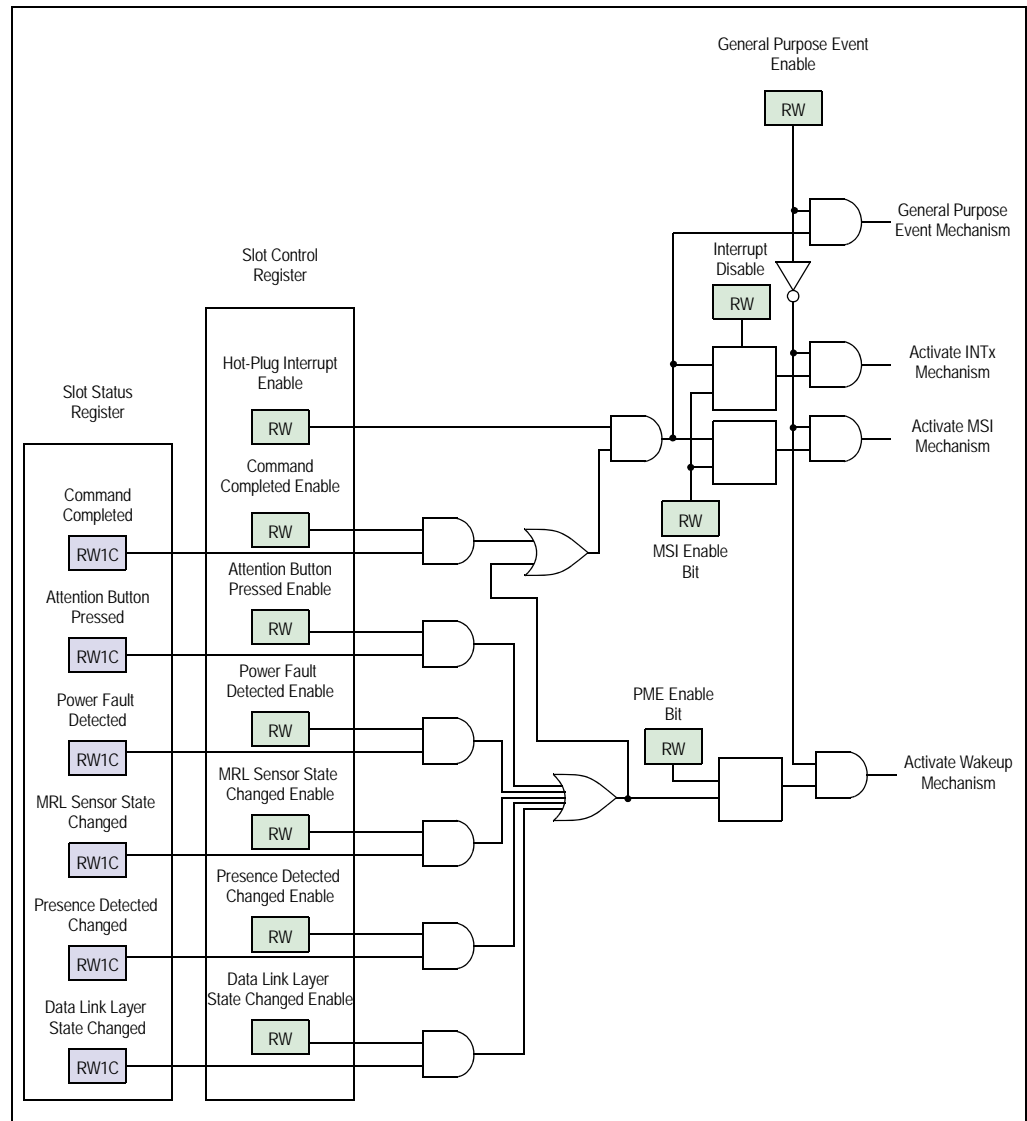

Figure 8.4 PES3T3 Hot-Plug Event Signalling

Notes

Hot-Swap

The PES3T3 is hot-swap capable and meets the following requirements

- All of the I/Os are tri-stated on reset (i.e., SerDes, GPIO, Master SMBus clock and data, etc.).
- All I/O cells function predictably from early power. This means that the device is able to tolerate a non-monotonic ramp-up as well as a rapid ramp-up of the DC power.
- All I/O cells are able to tolerate a precharge voltage.
- Since no clock is present during physical connection, the device will maintain all outputs in a high-impedance state even when no clock is present.
- The I/O cells meet VI requirements for hot-swap.
- The I/O cells respect the required leakage current limits over the entire input voltage range.

In summary, the PES3T3 meets all of the I/O requirements necessary to build a PICMG compliant hot-swap board or system. The hot-swap I/O buffers of the PES3T3 may also be used to construct proprietary hot-swap systems. See the 89HPES3T3 Data Sheet for a detailed specification of I/O buffer characteristics.



Configuration Registers

Notes

Configuration Space Organization

Each software visible register in the PES3T3 is contained in the PCI configuration space of one of the ports. Thus, there are no registers in the PES3T3 that cannot be accessed by the root. Each software visible register in the PES3T3 has a system address. The system address is formed by adding the PCI configuration space offset value of the register to the base address of the port in which it is located. The system address is used for serial EEPROM register initialization.

The base address for each PES3T3 port is listed in Table 9.1. The PCI configuration space offset addresses for registers in the upstream port are listed in Table 9.2 while the PCI configuration space offset addresses for registers in downstream ports are listed Table 9.3.

Base Address	PCI Configuration Space
0x0000	Port 0 configuration space (upstream port)
0x2000	Port 2 configuration space (downstream port)
0x3000	Port 3 configuration space (downstream port)

Table 9.1 Base Addresses for Port Configuration Space Registers

As shown in Figure 9.1, upstream and downstream ports share a similar PCI configuration space register layout. The upstream port contains global switch control and status registers. The downstream ports contain an MSI capability structure to generate MSIs as a result of hot-plug events, and the upstream port supports MSI capability structure to report internal parity errors.

Reading from an upstream port offset not defined in Table 9.2 or a downstream offset not defined in Table 9.3 returns a value of zero. Writes to such an offset complete successfully but modify no data and have no other effect.

Notes

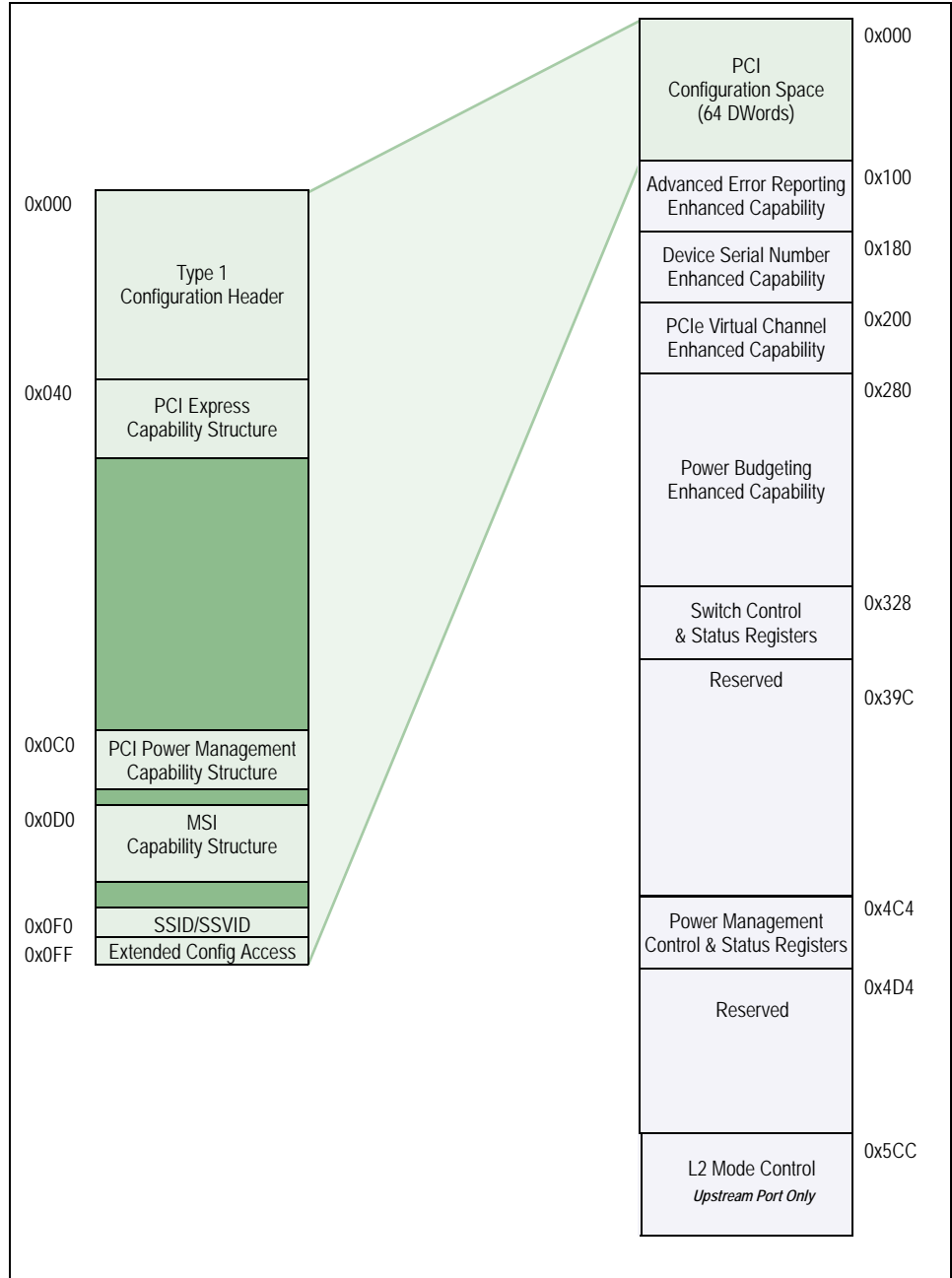

Figure 9.1 Port Configuration Space Organization

Notes

Upstream Port (Port 0)

Cfg. Offset	Size	Register Mnemonic	Register Definition
0x000	Word	P0_VID	VID - Vendor Identification Register (0x000) on page 9-11
0x002	Word	P0_DID	DID - Device Identification Register (0x002) on page 9-11
0x004	Word	P0_PCICMD	PCICMD - PCI Command Register (0x004) on page 9-11
0x006	Word	P0_PCISTS	PCISTS - PCI Status Register (0x006) on page 9-12
0x008	Byte	P0_RID	RID - Revision Identification Register (0x008) on page 9-13
0x009	3 Bytes	P0_CC CODE	CCODE - Class Code Register (0x009) on page 9-13
0x00C	Byte	P0_CLS	CLS - Cache Line Size Register (0x00C) on page 9-14
0x00D	Byte	P0_PLTIMER	PLTIMER - Primary Latency Timer (0x00D) on page 9-14
0x00E	Byte	P0_HDR	HDR - Header Type Register (0x00E) on page 9-14
0x00F	Byte	P0_BIST	BIST - Built-in Self Test Register (0x00F) on page 9-14
0x010	DWord	P0_BAR0	BAR0 - Base Address Register 0 (0x010) on page 9-14
0x014	DWord	P0_BAR1	BAR1 - Base Address Register 1 (0x014) on page 9-14
0x018	Byte	P0_PBUSN	PBUSN - Primary Bus Number Register (0x018) on page 9-15
0x019	Byte	P0_SBUSN	SBUSN - Secondary Bus Number Register (0x019) on page 9-15
0x01A	Byte	P0_SUBBUSN	SUBBUSN - Subordinate Bus Number Register (0x01A) on page 9-15
0x01B	Byte	P0_SLTIMER	SLTIMER - Secondary Latency Timer Register (0x01B) on page 9-15
0x01C	Byte	P0_IOBASE	IOBASE - I/O Base Register (0x01C) on page 9-15
0x01D	Byte	P0_IOLIMIT	IOLIMIT - I/O Limit Register (0x01D) on page 9-16
0x01E	Word	P0_SECSTS	SECSTS - Secondary Status Register (0x01E) on page 9-16
0x020	Word	P0_MBASE	MBASE - Memory Base Register (0x020) on page 9-16
0x022	Word	P0_MLIMIT	MLIMIT - Memory Limit Register (0x022) on page 9-17
0x024	Word	P0_PMBASE	PMBASE - Prefetchable Memory Base Register (0x024) on page 9-17
0x026	Word	P0_PMLIMIT	PMLIMIT - Prefetchable Memory Limit Register (0x026) on page 9-17
0x028	DWord	P0_PMBASEU	PMBASEU - Prefetchable Memory Base Upper Register (0x028) on page 9-18
0x02C	DWord	P0_PMLIMITU	PMLIMITU - Prefetchable Memory Limit Upper Register (0x02C) on page 9-18
0x030	Word	P0_IOBASEU	IOBASEU - I/O Base Upper Register (0x030) on page 9-18
0x032	Word	P0_IOLIMITU	IOLIMITU - I/O Limit Upper Register (0x032) on page 9-18
0x034	Byte	P0_CAPPTR	CAPPTR - Capabilities Pointer Register (0x034) on page 9-19
0x038	DWord	P0_EROMBASE	EROMBASE - Expansion ROM Base Address Register (0x038) on page 9-19
0x03C	Byte	P0_INTRLINE	INTRLINE - Interrupt Line Register (0x03C) on page 9-19
0x03D	Byte	P0_INTRPIN	INTRPIN - Interrupt PIN Register (0x03D) on page 9-19

Table 9.2 Upstream Port 0 Configuration Space Registers (Part 1 of 5)

Notes

Cfg. Offset	Size	Register Mnemonic	Register Definition
0x03E	Word	P0_BCTL	BCTL - Bridge Control Register (0x03E) on page 9-19
0x040	DWord	P0_PCIECAP	PCIECAP - PCI Express Capability (0x040) on page 9-21
0x044	DWord	P0_PCIEDCAP	PCIEDCAP - PCI Express Device Capabilities (0x044) on page 9-21
0x048	Word	P0_PCIEDCTL	PCIEDCTL - PCI Express Device Control (0x048) on page 9-22
0x04A	Word	P0_PCIEDSTS	PCIEDSTS - PCI Express Device Status (0x04A) on page 9-23
0x04C	DWord	P0_PCIELCAP	PCIELCAP - PCI Express Link Capabilities (0x04C) on page 9-24
0x050	Word	P0_PCIELCTL	PCIELCTL - PCI Express Link Control (0x050) on page 9-25
0x052	Word	P0_PCIELSTS	PCIELSTS - PCI Express Link Status (0x052) on page 9-26
0x064	DWord	P0_PCIEDCAP2	PCIEDCAP2 - PCI Express Device Capabilities 2 (0x064) on page 9-31
0x068	Word	P0_PCIEDCTL2	PCIEDCTL2 - PCI Express Device Control 2 (0x068) on page 9-31
0x06A	Word	P0_PCIEDSTS2	PCIEDSTS2 - PCI Express Device Status 2 (0x06A) on page 9-31
0x06C	DWord	P0_PCIELCAP2	PCIELCAP2 - PCI Express Link Capabilities 2 (0x06C) on page 9-31
0x070	Word	P0_PCIELCTL2	PCIELCTL2 - PCI Express Link Control 2 (0x070) on page 9-31
0x072	Word	P0_PCIELSTS2	PCIELSTS2 - PCI Express Link Status 2 (0x072) on page 9-32
0x0C0	DWord	P0_PMCAP	PMCAP - PCI Power Management Capabilities (0x0C0) on page 9-32
0x0C4	DWord	P0_PMCSR	PMCSR - PCI Power Management Control and Status (0x0C4) on page 9-33
0x0D0	DWord	Px_MSICAP	MSICAP - Message Signaled Interrupt Capability and Control (0x0D0) on page 9-34
0x0D4	DWord	Px_MSIADDR	MSIADDR - Message Signaled Interrupt Address (0x0D4) on page 9-34
0x0D8	DWord	Px_MSUIADDR	MSUIADDR - Message Signaled Interrupt Upper Address (0x0D8) on page 9-35
0x0DC	DWord	Px_MSIMDATA	MSIMDATA - Message Signaled Interrupt Message Data (0x0DC) on page 9-35
0x0F0	Dword	P0_SSIDSSVIDCAP	SSIDSSVIDCAP - Subsystem ID and Subsystem Vendor ID Capability (0x0F0) on page 9-35
0x0F4	Dword	P0_SSIDSSVID	SSIDSSVID - Subsystem ID and Subsystem Vendor ID (0x0F4) on page 9-36
0x0F8	Word	P0_ECFGADDR	ECFGADDR - Extended Configuration Space Access Address (0x0F8) on page 9-36
0x0FC	Word	P0_ECFGDATA	ECFGDATA - Extended Configuration Space Access Data (0x0FC) on page 9-36
0x100	Dword	P0_AERCAP	AERCAP - AER Capabilities (0x100) on page 9-37
0x104	Dword	P0_AERUES	AERUES - AER Uncorrectable Error Status (0x104) on page 9-37
0x108	Dword	P0_AERUEM	AERUEM - AER Uncorrectable Error Mask (0x108) on page 9-38
0x10C	Dword	P0_AERUESV	AERUESV - AER Uncorrectable Error Severity (0x10C) on page 9-39
0x110	Dword	P0_AERCES	AERCES - AER Correctable Error Status (0x110) on page 9-40

Table 9.2 Upstream Port 0 Configuration Space Registers (Part 2 of 5)

Notes

Cfg. Offset	Size	Register Mnemonic	Register Definition
0x114	Dword	P0_AERCEM	AERCEM - AER Correctable Error Mask (0x114) on page 9-41
0x118	Dword	P0_AERCTL	AERCTL - AER Control (0x118) on page 9-41
0x11C	Dword	P0_AERHL1DW	AERHL1DW - AER Header Log 1st Doubleword (0x11C) on page 9-42
0x120	Dword	P0_AERHL2DW	AERHL2DW - AER Header Log 2nd Doubleword (0x120) on page 9-42
0x124	Dword	P0_AERHL3DW	AERHL3DW - AER Header Log 3rd Doubleword (0x124) on page 9-42
0x128	Dword	P0_AERHL4DW	AERHL4DW - AER Header Log 4th Doubleword (0x128) on page 9-42
0x180	Dword	P0_SNUMCAP	SNUMCAP - Serial Number Capabilities (0x180) on page 9-43
0x184	Dword	P0_SNUMLDW	SNUMLDW - Serial Number Lower Doubleword (0x184) on page 9-43
0x188	Dword	P0_SNUMUDW	SNUMUDW - Serial Number Upper Doubleword (0x188) on page 9-43
0x200	DWord	P0_PCIEVCECAP	PCIEVCECAP - PCI Express VC Enhanced Capability Header (0x200) on page 9-43
0x204	DWord	P0_PVCCAP1	PVCCAP1- Port VC Capability 1 (0x204) on page 9-43
0x208	DWord	P0_PVCCAP2	PVCCAP2- Port VC Capability 2 (0x208) on page 9-44
0x20C	DWord	P0_PVCCTL	PVCCTL - Port VC Control (0x20C) on page 9-45
0x20E	DWord	P0_PVCSTS	PVCSTS - Port VC Status (0x20E) on page 9-45
0x210	DWord	P0_VCR0CAP	VCR0CAP- VC Resource 0 Capability (0x210) on page 9-45
0x214	DWord	P0_VCR0CTL	VCR0CTL- VC Resource 0 Control (0x214) on page 9-46
0x218	DWord	P0_VCR0STS	VCR0STS - VC Resource 0 Status (0x218) on page 9-47
0x220	DWord	P0_VCR0TBL0	VCR0TBL0 - VC Resource 0 Arbitration Table Entry 0 (0x220) on page 9-47
0x224	DWord	P0_VCR0TBL1	VCR0TBL1 - VC Resource 0 Arbitration Table Entry 1 (0x224) on page 9-48
0x228	DWord	P0_VCR0TBL2	VCR0TBL2 - VC Resource 0 Arbitration Table Entry 2 (0x228) on page 9-48
0x22C	DWord	P0_VCR0TBL3	VCR0TBL3 - VC Resource 0 Arbitration Table Entry 3 (0x22C) on page 9-49
0x280	Dword	P0_PWRBCAP	PWRBCAP - Power Budgeting Capabilities (0x280) on page 9-49
0x284	Dword	P0_PWRBSEL	PWRBSEL - Power Budgeting Data Select (0x284) on page 9-50
0x288	Dword	P0_PWRBD	PWRBD - Power Budgeting Data (0x288) on page 9-50
0x28C	Dword	P0_PWRBPBC	PWRBPBC - Power Budgeting Power Budget Capability (0x28C) on page 9-50
0x300	Dword	P0_PWRBDV0	PWRBDV[9:0] - Power Budgeting Data Value [9:0] (0x300) on page 9-50
0x304	Dword	P0_PWRBDV1	PWRBDV[9:0] - Power Budgeting Data Value [9:0] (0x300) on page 9-50

Table 9.2 Upstream Port 0 Configuration Space Registers (Part 3 of 5)

Notes

Cfg. Offset	Size	Register Mnemonic	Register Definition
0x308	Dword	P0_PWRBDV2	PWRBDV[9:0] - Power Budgeting Data Value [9:0] (0x300) on page 9-50
0x30C	Dword	P0_PWRBDV3	PWRBDV[9:0] - Power Budgeting Data Value [9:0] (0x300) on page 9-50
0x310	Dword	P0_PWRBDV4	PWRBDV[9:0] - Power Budgeting Data Value [9:0] (0x300) on page 9-50
0x314	Dword	P0_PWRBDV5	PWRBDV[9:0] - Power Budgeting Data Value [9:0] (0x300) on page 9-50
0x318	Dword	P0_PWRBDV6	PWRBDV[9:0] - Power Budgeting Data Value [9:0] (0x300) on page 9-50
0x31C	Dword	P0_PWRBDV7	PWRBDV[9:0] - Power Budgeting Data Value [9:0] (0x300) on page 9-50
0x320	Dword	P0_PWRBDV8	PWRBDV[9:0] - Power Budgeting Data Value [9:0] (0x300) on page 9-50
0x324	Dword	P0_PWRBDV9	PWRBDV[9:0] - Power Budgeting Data Value [9:0] (0x300) on page 9-50
0x328	DWord	SWSTS	SWSTS - Switch Status (0x328) on page 9-51
0x32C	DWord	SWCTL	SWCTL - Switch Control (0x32C) on page 9-51
0x330	DWord	HPCFGCTL	HPCFGCTL - Hot-Plug Configuration Control (0x330) on page 9-53
0x334	DWord	GPR	GPR - General Purpose Register (0x334) on page 9-54
0x338	DWord	GPIOFUNC	GPIOFUNC - General Purpose I/O Control Function (0x338) on page 9-55
0x33C	DWord	GPIOCFG	GPIOCFG - General Purpose I/O Configuration (0x33C) on page 9-55
0x340	DWord	GPIOD	GPIOD - General Purpose I/O Data (0x340) on page 9-55
0x344	DWord	SMBUSSTS	SMBUSSTS - SMBus Status (0x344) on page 9-55
0x348	DWord	SMBUSCTL	SMBUSCTL - SMBus Control (0x348) on page 9-56
0x34C	DWord	EEPROMINTF	EEPROMINTF - Serial EEPROM Interface (0x34C) on page 9-57
0x350	DWord	IOEXPINTF	IOEXPINTF - I/O Expander Interface (0x350) on page 9-57
0x354	DWord	IOEXPADDR0	IOEXPADDR0 - SMBus I/O Expander Address 0 (0x354) on page 9-58
0x358	DWord	IOEXPADDR1	IOEXPADDR1 - SMBus I/O Expander Address 1 (0x358) on page 9-59
0x35C	DWord	GPECTL	GPECTL - General Purpose Event Control (0x35C) on page 9-59
0x360	DWord	GPESTS	GPESTS - General Purpose Event Status (0x360) on page 9-59
0x4D4	Dword	P0_SWPECTL	SWPECTL - Switch Parity Error Control (0x4D4) on page 9-60
0x4D8	Dword	P0_SWERRSTS	SWERRSTS - Switch Internal Error Status (0x4D8) on page 9-60
0x4DC	Dword	P0_SWERRCTL	SWERRCTL - Switch Internal Error Reporting Control (0x4DC) on page 9-61
0x4E0	Dword	P0_SWERRCNT	SWERRCNT - Switch Internal Error Count (0x4E0) on page 9-61
0x4E4	Dword	P0_SWTOCTL	SWTOCTL - Switch Time-Out Control (0x4E4) on page 9-61

Table 9.2 Upstream Port 0 Configuration Space Registers (Part 4 of 5)

Notes

Cfg. Offset	Size	Register Mnemonic	Register Definition
0x4E8	Dword	P0_SWTORCTL	SWTORCTL - Switch Time-Out Reporting Control (0x4E8) on page 9-62
0x4EC	Dword	P0_SWTOCNT	SWTOCNT - Switch Time-Out Count (0x4EC) on page 9-62
0x5CC	Dword	P0_WAKEUPCNT L	WAKEUPCNTL - Wakeup Protocol Control Register (0x5CC) on page 9-63

Table 9.2 Upstream Port 0 Configuration Space Registers (Part 5 of 5)

Downstream Ports (Ports 2 and 3)

Cfg. Offset	Size	Register Mnemonic	Register Definition
0x000	Word	Px_VID	VID - Vendor Identification Register (0x000) on page 9-11
0x002	Word	Px_DID	DID - Device Identification Register (0x002) on page 9-11
0x004	Word	Px_PCICMD	PCICMD - PCI Command Register (0x004) on page 9-11
0x006	Word	Px_PCISTS	PCISTS - PCI Status Register (0x006) on page 9-12
0x008	Byte	Px_RID	RID - Revision Identification Register (0x008) on page 9-13
0x009	3 Bytes	Px_CC CODE	CCODE - Class Code Register (0x009) on page 9-13
0x00C	Byte	Px_CLS	CLS - Cache Line Size Register (0x00C) on page 9-14
0x00D	Byte	Px_PLTIMER	PLTIMER - Primary Latency Timer (0x00D) on page 9-14
0x00E	Byte	Px_HDR	HDR - Header Type Register (0x00E) on page 9-14
0x00F	Byte	Px_BIST	BIST - Built-in Self Test Register (0x00F) on page 9-14
0x010	DWord	Px_BAR0	BAR0 - Base Address Register 0 (0x010) on page 9-14
0x014	DWord	Px_BAR1	BAR1 - Base Address Register 1 (0x014) on page 9-14
0x018	Byte	Px_PBUSN	PBUSN - Primary Bus Number Register (0x018) on page 9-15
0x019	Byte	Px_SBUSN	SBUSN - Secondary Bus Number Register (0x019) on page 9-15
0x01A	Byte	Px_SUBBUSN	SUBBUSN - Subordinate Bus Number Register (0x01A) on page 9-15
0x01B	Byte	Px_SLTIMER	SLTIMER - Secondary Latency Timer Register (0x01B) on page 9-15
0x01C	Byte	Px_IOBASE	IOBASE - I/O Base Register (0x01C) on page 9-15
0x01D	Byte	Px_IOLIMIT	IOLIMIT - I/O Limit Register (0x01D) on page 9-16
0x01E	Word	Px_SECSTS	SECSTS - Secondary Status Register (0x01E) on page 9-16
0x020	Word	Px_MBASE	MBASE - Memory Base Register (0x020) on page 9-16
0x022	Word	Px_MLIMIT	MLIMIT - Memory Limit Register (0x022) on page 9-17
0x024	Word	Px_PMBASE	PMBASE - Prefetchable Memory Base Register (0x024) on page 9-17
0x026	Word	Px_PMLIMIT	PMLIMIT - Prefetchable Memory Limit Register (0x026) on page 9-17
0x028	DWord	Px_PMBASEU	PMBASEU - Prefetchable Memory Base Upper Register (0x028) on page 9-18

Table 9.3 Downstream Ports 2 through 5 Configuration Space Registers (Part 1 of 4)

Notes

Cfg. Offset	Size	Register Mnemonic	Register Definition
0x02C	DWord	Px_PMLIMITU	PMLIMITU - Prefetchable Memory Limit Upper Register (0x02C) on page 9-18
0x030	Word	Px_IOBASEU	IOBASEU - I/O Base Upper Register (0x030) on page 9-18
0x032	Word	Px_IOLIMITU	IOLIMITU - I/O Limit Upper Register (0x032) on page 9-18
0x034	Byte	Px_CAPPTR	CAPPTR - Capabilities Pointer Register (0x034) on page 9-19
0x038	DWord	Px_EROMBASE	EROMBASE - Expansion ROM Base Address Register (0x038) on page 9-19
0x03C	Byte	Px_INTRLINE	INTRLINE - Interrupt Line Register (0x03C) on page 9-19
0x03D	Byte	Px_INTRPIN	INTRPIN - Interrupt PIN Register (0x03D) on page 9-19
0x03E	Word	Px_BCTL	BCTL - Bridge Control Register (0x03E) on page 9-19
0x040	DWord	Px_PCIECAP	PCIECAP - PCI Express Capability (0x040) on page 9-21
0x044	DWord	Px_PCIEDCAP	PCIEDCAP - PCI Express Device Capabilities (0x044) on page 9-21
0x048	Word	Px_PCIEDCTL	PCIEDCTL - PCI Express Device Control (0x048) on page 9-22
0x04A	Word	Px_PCIEDSTS	PCIEDSTS - PCI Express Device Status (0x04A) on page 9-23
0x04C	DWord	Px_PCIELCAP	PCIELCAP - PCI Express Link Capabilities (0x04C) on page 9-24
0x050	Word	Px_PCIELCTL	PCIELCTL - PCI Express Link Control (0x050) on page 9-25
0x052	Word	Px_PCIELSTS	PCIELSTS - PCI Express Link Status (0x052) on page 9-26
0x054	DWord	Px_PCIESCAP	PCIESCAP - PCI Express Slot Capabilities (0x054) on page 9-27
0x058	Word	Px_PCIESCTL	PCIESCTL - PCI Express Slot Control (0x058) on page 9-28
0x05A	Word	Px_PCIESSTS	PCIESSTS - PCI Express Slot Status (0x05A) on page 9-30
0x064	DWord	Px_PCIEDCAP2	PCIEDCAP2 - PCI Express Device Capabilities 2 (0x064) on page 9-31
0x068	Word	Px_PCIEDCTL2	PCIEDCTL2 - PCI Express Device Control 2 (0x068) on page 9-31
0x06A	Word	Px_PCIEDSTS2	PCIEDSTS2 - PCI Express Device Status 2 (0x06A) on page 9-31
0x06C	DWord	Px_PCIELCAP2	PCIELCAP2 - PCI Express Link Capabilities 2 (0x06C) on page 9-31
0x070	Word	Px_PCIELCTL2	PCIELCTL2 - PCI Express Link Control 2 (0x070) on page 9-31
0x072	Word	Px_PCIELSTS2	PCIELSTS2 - PCI Express Link Status 2 (0x072) on page 9-32
0x074	DWord	Px_PCIESCAP2	PCIESCAP2 - PCI Express Slot Capabilities 2 (0x074) on page 9-32
0x078	Word	Px_PCIESCTL2	PCIESCTL2 - PCI Express Slot Control 2 (0x078) on page 9-32
0x07A	Word	Px_PCIESSTS2	PCIESSTS2 - PCI Express Slot Status 2 (0x07A) on page 9-32
0x0C0	DWord	Px_PMCAP	PMCAP - PCI Power Management Capabilities (0x0C0) on page 9-32
0x0C4	DWord	Px_PMCSR	PMCSR - PCI Power Management Control and Status (0x0C4) on page 9-33
0x0D0	DWord	Px_MSICAP	MSICAP - Message Signaled Interrupt Capability and Control (0x0D0) on page 9-34
0x0D4	DWord	Px_MSIADDR	MSIADDR - Message Signaled Interrupt Address (0x0D4) on page 9-34

Table 9.3 Downstream Ports 2 through 5 Configuration Space Registers (Part 2 of 4)

Notes

Cfg. Offset	Size	Register Mnemonic	Register Definition
0x0D8	DWord	Px_MSUIADDR	MSUIADDR - Message Signaled Interrupt Upper Address (0x0D8) on page 9-35
0x0DC	DWord	Px_MSIMDATA	MSIMDATA - Message Signaled Interrupt Message Data (0x0DC) on page 9-35
0x0F0	Dword	Px_SSIDSSVIDCAP	SSIDSSVIDCAP - Subsystem ID and Subsystem Vendor ID Capability (0x0F0) on page 9-35
0x0F4	Dword	Px_SSIDSSVID	SSIDSSVID - Subsystem ID and Subsystem Vendor ID (0x0F4) on page 9-36
0x0F8	Word	Px_ECFGADDR	ECFGADDR - Extended Configuration Space Access Address (0x0F8) on page 9-36
0x0FC	Word	Px_ECFGDATA	ECFGDATA - Extended Configuration Space Access Data (0x0FC) on page 9-36
0x100	Dword	Px_AERCAP	AERCAP - AER Capabilities (0x100) on page 9-37
0x104	Dword	Px_AERUES	AERUES - AER Uncorrectable Error Status (0x104) on page 9-37
0x108	Dword	Px_AERUEM	AERUEM - AER Uncorrectable Error Mask (0x108) on page 9-38
0x10C	Dword	Px_AERUESV	AERUESV - AER Uncorrectable Error Severity (0x10C) on page 9-39
0x110	Dword	Px_AERCES	AERCES - AER Correctable Error Status (0x110) on page 9-40
0x114	Dword	Px_AERCEM	AERCEM - AER Correctable Error Mask (0x114) on page 9-41
0x118	Dword	Px_AERCTL	AERCTL - AER Control (0x118) on page 9-41
0x11C	Dword	Px_AERHL1DW	AERHL1DW - AER Header Log 1st Doubleword (0x11C) on page 9-42
0x120	Dword	Px_AERHL2DW	AERHL2DW - AER Header Log 2nd Doubleword (0x120) on page 9-42
0x124	Dword	Px_AERHL3DW	AERHL3DW - AER Header Log 3rd Doubleword (0x124) on page 9-42
0x128	Dword	Px_AERHL4DW	AERHL4DW - AER Header Log 4th Doubleword (0x128) on page 9-42
0x180	Dword	Px_SNUMCAP	SNUMCAP - Serial Number Capabilities (0x180) on page 9-43
0x184	Dword	Px_SNUMLDW	SNUMLDW - Serial Number Lower Doubleword (0x184) on page 9-43
0x188	Dword	Px_SNUMUDW	SNUMUDW - Serial Number Upper Doubleword (0x188) on page 9-43
0x200	DWord	Px_PCIEVCECAP	PCIEVCECAP - PCI Express VC Enhanced Capability Header (0x200) on page 9-43
0x204	DWord	Px_PVCCAP1	PVCCAP1- Port VC Capability 1 (0x204) on page 9-43
0x208	DWord	Px_PVCCAP2	PVCCAP2- Port VC Capability 2 (0x208) on page 9-44
0x20C	Word	Px_PVCCTL	PVCCTL - Port VC Control (0x20C) on page 9-45
0x20E	Word	Px_PVCSTS	PVCSTS - Port VC Status (0x20E) on page 9-45
0x210	DWord	Px_VCR0CAP	VCR0CAP- VC Resource 0 Capability (0x210) on page 9-45
0x214	DWord	Px_VCR0CTL	VCR0CTL- VC Resource 0 Control (0x214) on page 9-46
0x218	DWord	Px_VCR0STS	VCR0STS - VC Resource 0 Status (0x218) on page 9-47

Table 9.3 Downstream Ports 2 through 5 Configuration Space Registers (Part 3 of 4)

Notes

Cfg. Offset	Size	Register Mnemonic	Register Definition
0x280	Dword	Px_PWRBCAP	PWRBCAP - Power Budgeting Capabilities (0x280) on page 9-49
0x284	Dword	Px_PWRBDESEL	PWRBDESEL - Power Budgeting Data Select (0x284) on page 9-50
0x288	Dword	Px_PWRBD	PWRBD - Power Budgeting Data (0x288) on page 9-50
0x28C	Dword	Px_PWRBPBC	PWRBPBC - Power Budgeting Power Budget Capability (0x28C) on page 9-50
0x300	Dword	Px_PWRBDV0	PWRBDV[9:0] - Power Budgeting Data Value [9:0] (0x300) on page 9-50
0x304	Dword	Px_PWRBDV1	PWRBDV[9:0] - Power Budgeting Data Value [9:0] (0x300) on page 9-50
0x308	Dword	Px_PWRBDV2	PWRBDV[9:0] - Power Budgeting Data Value [9:0] (0x300) on page 9-50
0x30C	Dword	Px_PWRBDV3	PWRBDV[9:0] - Power Budgeting Data Value [9:0] (0x300) on page 9-50
0x310	Dword	Px_PWRBDV4	PWRBDV[9:0] - Power Budgeting Data Value [9:0] (0x300) on page 9-50
0x314	Dword	Px_PWRBDV5	PWRBDV[9:0] - Power Budgeting Data Value [9:0] (0x300) on page 9-50
0x318	Dword	Px_PWRBDV6	PWRBDV[9:0] - Power Budgeting Data Value [9:0] (0x300) on page 9-50
0x31C	Dword	Px_PWRBDV7	PWRBDV[9:0] - Power Budgeting Data Value [9:0] (0x300) on page 9-50
0x320	Dword	Px_PWRBDV8	PWRBDV[9:0] - Power Budgeting Data Value [9:0] (0x300) on page 9-50
0x324	Dword	Px_PWRBDV9	PWRBDV[9:0] - Power Budgeting Data Value [9:0] (0x300) on page 9-50
0x4D4	Dword	Px_SWPECTL	SWPECTL - Switch Parity Error Control (0x4D4) on page 9-60
0x4D8	Dword	Px_SWERRSTS	SWERRSTS - Switch Internal Error Status (0x4D8) on page 9-60
0x4DC	Dword	Px_SWERRCTL	SWERRCTL - Switch Internal Error Reporting Control (0x4DC) on page 9-61
0x4E0	Dword	Px_SWERRCNT	SWERRCNT - Switch Internal Error Count (0x4E0) on page 9-61
0x4E4	Dword	Px_SWTOCTL	SWTOCTL - Switch Time-Out Control (0x4E4) on page 9-61
0x4E8	Dword	Px_SWTORCTL	SWTORCTL - Switch Time-Out Reporting Control (0x4E8) on page 9-62
0x4EC	Dword	Px_SWTOCNT	SWTOCNT - Switch Time-Out Count (0x4EC) on page 9-62

Table 9.3 Downstream Ports 2 through 5 Configuration Space Registers (Part 4 of 4)

Notes

Register Definitions

Type 1 Configuration Header Registers

VID - Vendor Identification Register (0x000)

Bit Field	Field Name	Type	Default Value	Description
15:0	VID	RO	0x111D	Vendor Identification. This field contains the 16-bit vendor ID value assigned to IDT. See section Vendor ID on page 1-8.

DID - Device Identification Register (0x002)

Bit Field	Field Name	Type	Default Value	Description
15:0	DID	RO	-	Device Identification. This field contains the 16-bit device ID assigned by IDT to this bridge. See section Device ID on page 1-8.

PCICMD - PCI Command Register (0x004)

Bit Field	Field Name	Type	Default Value	Description
0	IOAE	RW	0x0	I/O Access Enable. When this bit is cleared, the bridge does not respond to I/O accesses from the primary bus specified by IOBASE and IOLIMIT. 0x0 - (disable) Disable I/O space. 0x1 - (enable) Enable I/O space.
1	MAE	RW	0x0	Memory Access Enable. When this bit is cleared, the bridge does not respond to memory and prefetchable memory space access from the primary bus specified by MBASE, MLIMIT, PMBASE and PMLIMIT. 0x0 - (disable) Disable memory space. 0x1 - (enable) Enable memory space.
2	BME	RW	0x0	Bus Master Enable. When this bit is cleared, the bridge does not issue requests (e.g., memory, I/O and MSIs since they are in-band writes) on behalf of subordinate devices and responds to non-posted transactions with a Unsupported Request (UR) completion. This bit does not affect completions in either direction or the forwarding of non memory or I/O requests. 0x0 - (disable) Disable request forwarding. 0x1 - (enable) Enable request forwarding.
3	SSE	RO	0x0	Special Cycle Enable. Not applicable.
4	MWI	RO	0x0	Memory Write Invalidate. Not applicable.
5	VGAS	RO	0x0	VGA Palette Snoop. Not applicable.

Notes

Bit Field	Field Name	Type	Default Value	Description
6	PERRE	RW	0x0	Parity Error Enable. The Master Data Parity Error bit is set in the PCI Status register (PCISTS) if this bit is set and the bridge receives a poisoned completion or generates a poisoned write. If this bit is cleared, then the Master Data Parity Error bit in the PCI Status register is never set. 0x0 -(disable) Disable Master Parity Error bit reporting. 0x1 -(enable) Enable Master Parity Error bit reporting.
7	ADSTEP	RO	0x0	Address Data Stepping. Not applicable.
8	SERRE	RW	0x0	SERR Enable. Non-fatal and fatal errors detected by the bridge are reported to the Root Complex when this bit is set or the bits in the PCI Express Device Control register are set (see PCIEDCTL - PCI Express Device Control (0x048) on page 9-22). In addition, when this bit is set it enables the forwarding of ERR_NONFATAL and ERR_FATAL error messages from the secondary to the primary interface. ERR_COR messages are unaffected by this bit and are always forwarded. 0x0 -(disable) Disable non-fatal and fatal error reporting if also disabled in Device Control register. 0x1 -(enable) Enable non-fatal and fatal error reporting.
9	FB2B	RO	0x0	Fast Back-to-Back Enable. Not applicable.
10	INTXD	RW	0x0	INTx Disable. Controls the ability of the PCI-PCI bridge to generate an INTx interrupt message. When this bit is cleared, any interrupts generated by this bridge are negated. This may result in a change in the resolved interrupt state of the bridge. This bit has no effect on interrupts forwarded from the secondary to the primary interface.
15:11	Reserved	RO	0x0	Reserved field.

PCISTS - PCI Status Register (0x006)

Bit Field	Field Name	Type	Default Value	Description
2:0	Reserved	RO	0x0	Reserved field.
3	INTS	RO	0x0	INTx Status. This bit is set when an INTx interrupt is pending from the device. INTx emulation interrupts forwarded by switch ports from devices downstream of the bridge are not reflected in this bit. For downstream ports, this bit is set if an interrupt has been "asserted" by the corresponding port's hot-plug controller. In the upstream port, this field is set if an internal parity error has been detected or config access error has occurred.
4	CAPL	RO	0x1	Capabilities List. This bit is hardwired to one to indicate that the bridge implements an extended capability list item.
5	C66MHZ	RO	0x0	66 MHz Capable. Not applicable.
6	Reserved	RO	0x0	Reserved field.

Notes

Bit Field	Field Name	Type	Default Value	Description
7	FB2B	RO	0x0	Fast Back-to-Back (FB2B). Not applicable.
8	MDPED	RW1C	0x0	Master Data Parity Error Detected. This bit is set when the PERRE bit is set in the PCI Command register and the bridge receives a poisoned completion or generates a poisoned write request on the primary side of the bridge. 0x0 - (noerror) no error. 0x1 - (error) Poisoned write request or completion received on primary side.
10:9	DEVT	RO	0x0	DEVSEL# Timing. Not applicable.
11	STAS	RO	0x0	Signaled Target Abort. Not applicable since a target abort is never signalled.
12	RTAS	RO	0x0	Received Target Abort. Not applicable.
13	RMAS	RO	0x0	Received Master Abort. Not applicable.
14	SSE	RW1C	0x0	Signaled System Error. This bit is set when the bridge sends a ERR_FATAL or ERR_NONFATAL message and the SERR Enable (SERRE) bit is set in the PCICMD register. 0x0 - (noerror) no error. 0x1 - (error) This bit is set when a fatal or non-fatal error is signalled.
15	DPE	RW1C	0x0	Detected Parity Error. This bit is set by the bridge whenever it receives a poisoned TLP on the primary side regardless of the state of the PERRE bit in the PCI Command register.

RID - Revision Identification Register (0x008)

Bit Field	Field Name	Type	Default Value	Description
7:0	RID	RWL	-	Revision ID. This field contains the revision identification number for the device. See section Revision ID on page 1-8.

CCODE - Class Code Register (0x009)

Bit Field	Field Name	Type	Default Value	Description
7:0	INTF	RO	0x00	Interface. This value indicates that the device is a PCI-PCI bridge that does not support subtractive decode.
15:8	SUB	RO	0x04	Sub Class Code. This value indicates that the device is a PCI-PCI bridge.
23:16	BASE	RO	0x06	Base Class Code. This value indicates that the device is a bridge.

Notes

CLS - Cache Line Size Register (0x00C)

Bit Field	Field Name	Type	Default Value	Description
7:0	CLS	RW	0x00	Cache Line Size. This field has no effect on the bridge's functionality but may be read and written by software. This field is implemented for compatibility with legacy software.

PLTIMER - Primary Latency Timer (0x00D)

Bit Field	Field Name	Type	Default Value	Description
7:0	PLTIMER	RO	0x00	Primary Latency Timer. Not applicable.

HDR - Header Type Register (0x00E)

Bit Field	Field Name	Type	Default Value	Description
7:0	HDR	RO	0x01	Header Type. This value indicates a type 1 header with a single function bridge layout.

BIST - Built-in Self Test Register (0x00F)

Bit Field	Field Name	Type	Default Value	Description
7:0	BIST	RO	0x0	BIST. This value indicates that the bridge does not implement BIST.

BAR0 - Base Address Register 0 (0x010)

Bit Field	Field Name	Type	Default Value	Description
31:0	BAR	RO	0x0	Base Address Register. Not applicable.

BAR1 - Base Address Register 1 (0x014)

Bit Field	Field Name	Type	Default Value	Description
31:0	BAR	RO	0x0	Base Address Register. Not applicable.

Notes

PBUSN - Primary Bus Number Register (0x018)

Bit Field	Field Name	Type	Default Value	Description
7:0	PBUSN	RW	0x0	Primary Bus Number. This field is used to record the bus number of the PCI bus segment to which the primary interface of the bridge is connected. This field has no functional effect within the PES3T3 but is implemented as a read/write register for software compatibility.

SBUSN - Secondary Bus Number Register (0x019)

Bit Field	Field Name	Type	Default Value	Description
7:0	SBUSN	RW	0x0	Secondary Bus Number. This field is used to record the bus number of the PCI bus segment to which the secondary interface of the bridge is connected.

SUBUSN - Subordinate Bus Number Register (0x01A)

Bit Field	Field Name	Type	Default Value	Description
7:0	SUBUSN	RW	0x0	Subordinate Bus Number. The Subordinate Bus Number register is used to record the bus number of the highest numbered PCI bus segment which is behind (or subordinate to) the bridge.

SLTIMER - Secondary Latency Timer Register (0x01B)

Bit Field	Field Name	Type	Default Value	Description
7:0	SLTIMER	RO	0x0	Secondary Latency Timer. Not applicable.

IOBASE - I/O Base Register (0x01C)

Bit Field	Field Name	Type	Default Value	Description
0	IOCAP	RWL	0x1	I/O Capability. Indicates if the bridge supports 16-bit or 32-bit I/O addressing. 0x0 - (io16) 16-bit I/O addressing. 0x1 - (io32) 32-bit I/O addressing.
3:1	Reserved	RO	0x0	Reserved field.
7:4	IOBASE	RW	0xF	I/O Base. The IOBASE and IOLIMIT registers are used to control the forwarding of I/O transactions between the primary and secondary interfaces of the bridge. This field contains A[15:12] of the lowest I/O address aligned on a 4KB boundary that is below the primary interface of the bridge.

Notes

IOLIMIT - I/O Limit Register (0x01D)

Bit Field	Field Name	Type	Default Value	Description
0	IOCAP	RO	0x1	I/O Capability. Indicates if the bridge supports 16-bit or 32-bit I/O addressing. This bit always reflects the value of the IOCAP field in the IOBASE register.
3:1	Reserved	RO	0x0	Reserved field.
7:4	IOLIMIT	RW	0x0	I/O Limit. The IOBASE and IOLIMIT registers are used to control the forwarding of I/O transactions between the primary and secondary interfaces of the bridge. This field contains A[15:12] of the highest I/O address, with A[11:0] assumed to be 0xFFF, that is below the primary interface of the bridge.

SECSTS - Secondary Status Register (0x01E)

Bit Field	Field Name	Type	Default Value	Description
7:0	Reserved	RO	0x0	Reserved field.
8	MDPED	RW1C	0x0	Master Data Parity Error. This bit is controlled by the Parity Error Response Enable bit in the Bridge Control register. If the Parity Response Enable bit is cleared, then this bit is never set. Otherwise, this bit is set if the bridge receives a poisoned completion or generates a poisoned write on the secondary side of the bridge.
10:9	DVSEL	RO	0x0	Not applicable.
11	STAS	RO	0x0	Signaled Target Abort Status. Not applicable.
12	RTAS	RO	0x0	Received Target Abort Status. Not applicable.
13	RMAS	RO	0x0	Received Master Abort Status. Not applicable.
14	RSE	RW1C	0x0	Received System Error. This bit is controlled by the SERR enable bit in the Bridge Control (BCTL) register. If the SERRE bit is cleared in BCTL, then this bit is never set. Otherwise, this bit is set if the secondary side of the bridge receives an ERR_FATAL or ERR_NONFATAL message.
15	DPE	RW1C	0x0	Detected Parity Error. This bit is set by the bridge whenever it receives a poisoned TLP on the secondary side regardless of the state of the PERRE bit in the PCI Command register

MBASE - Memory Base Register (0x020)

Bit Field	Field Name	Type	Default Value	Description
3:0	Reserved	RO	0x0	Reserved field.

Notes

Bit Field	Field Name	Type	Default Value	Description
15:4	MBASE	RW	0xFFF	Memory Address Base. The MBASE and MLIMIT registers are used to control the forwarding of non-prefetchable transactions between the primary and secondary interfaces of the bridge. This field contains A[31:20] of the lowest address aligned on a 1MB boundary that is below the primary interface of the bridge.

MLIMIT - Memory Limit Register (0x022)

Bit Field	Field Name	Type	Default Value	Description
3:0	Reserved	RO	0x0	Reserved field.
15:4	MLIMIT	RW	0x0	Memory Address Limit. The MBASE and MLIMIT registers are used to control the forwarding of non-prefetchable transactions between the primary and secondary interfaces of the bridge. This field contains A[31:20] of the highest address, with A[19:0] assumed to be 0xF_FFFF, that is below the primary interface of the bridge.

PMBASE - Prefetchable Memory Base Register (0x024)

Bit Field	Field Name	Type	Default Value	Description
0	PMCAP	RWL	0x1	Prefetchable Memory Capability. Indicates if the bridge supports 32-bit or 64-bit prefetchable memory addressing. 0x0 - (prefmem32) 32-bit prefetchable memory addressing. 0x1 - (prefmem64) 64-bit prefetchable memory addressing.
3:1	Reserved	RO	0x0	Reserved field.
15:4	PMBASE	RW	0xFFF	Prefetchable Memory Address Base. The PMBASE, PMBASEU, PMLIMIT and PMLIMITU registers are used to control the forwarding of prefetchable transactions between the primary and secondary interfaces of the bridge. This field contains A[31:20] of the lowest memory address aligned on a 1MB boundary that is below the primary interface of the bridge. PMBASEU specifies the remaining bits.

PMLIMIT - Prefetchable Memory Limit Register (0x026)

Bit Field	Field Name	Type	Default Value	Description
0	PMCAP	RO	0x1	Prefetchable Memory Capability. Indicates if the bridge supports 32-bit or 64-bit prefetchable memory addressing. This bit always reflects the value in the PMCAP field in the PMBASE register.
3:1	Reserved	RO	0x0	Reserved field.

Notes

Bit Field	Field Name	Type	Default Value	Description
15:4	PMLIMIT	RW	0x0	Prefetchable Memory Address Limit. The PMBASE, PMBASEU, PMLIMIT and PMLIMITU registers are used to control the forwarding of prefetchable transactions between the primary and secondary interfaces of the bridge. This field contains A[31:20] of the highest memory address, with A[19:0] assumed to be 0xF_FFFF, that is below the primary interface of the bridge. PMLIMITU specifies the remaining bits.

PMBASEU - Prefetchable Memory Base Upper Register (0x028)

Bit Field	Field Name	Type	Default Value	Description
31:0	PMBASEU	RW	0xFFFF_FFFF	Prefetchable Memory Address Base Upper. This field specifies the upper 32-bits of PMBASE when 64-bit addressing is used. When the PMCAP field in the PMBASE register is cleared, this field becomes read-only with a value of zero.

PMLIMITU - Prefetchable Memory Limit Upper Register (0x02C)

Bit Field	Field Name	Type	Default Value	Description
31:0	PMLIMITU	RW	0x0	Prefetchable Memory Address Limit Upper. This field specifies the upper 32-bits of PMLIMIT. When the PMCAP field in the PMBASE register is cleared, this field becomes read-only with a value of zero.

IOBASEU - I/O Base Upper Register (0x030)

Bit Field	Field Name	Type	Default Value	Description
15:0	IOBASEU	RW	0xFFFF	I/O Address Base Upper. This field specifies the upper 16-bits of IOBASE. When the IOCAP field in the IOBASE register is cleared, this field becomes read-only with a value of zero.

IOLIMITU - I/O Limit Upper Register (0x032)

Bit Field	Field Name	Type	Default Value	Description
15:0	IOLIMITU	RW	0x0	Prefetchable IO Limit Upper. This field specifies the upper 16-bits of IOLIMIT. When the IOCAP field in the IOBASE register is cleared, this field becomes read-only with a value of zero.

Notes

CAPPTR - Capabilities Pointer Register (0x034)

Bit Field	Field Name	Type	Default Value	Description
7:0	CAPPTR	RWL	0x40	Capabilities Pointer. This field specifies a pointer to the head of the capabilities structure.

EROMBASE - Expansion ROM Base Address Register (0x038)

Bit Field	Field Name	Type	Default Value	Description
31:0	EROMBASE	RO	0x0	Expansion ROM Base Address. The bridge does not implement an expansion ROM. Thus, this field is hardwired to zero.

INTRLINE - Interrupt Line Register (0x03C)

Bit Field	Field Name	Type	Default Value	Description
7:0	INTRLINE	RW	0x0	Interrupt Line. This register communicates interrupt line routing information. Values in this register are programmed by system software and are system architecture specific. The bridge does not use the value in this register. Legacy interrupts may be implemented by downstream ports.

INTRPIN - Interrupt PIN Register (0x03D)

Bit Field	Field Name	Type	Default Value	Description
7:0	INTRPIN	RWL	0x0	Interrupt Pin. Interrupt pin or legacy interrupt messages are not used by the bridge by default. However, they can be used for hot-plug by the downstream ports. This field should only be configured with values of 0x0 through 0x4. 0x0 - (none) Bridge does not generate any interrupts. 0x1 - (INTA) Bridge generates INTA interrupts. 0x2 - (INTB) Bridge generates INTB interrupts. 0x3 - (INTC) Bridge generates INTC interrupts. 0x4 - (INTD) Bridge generates INTD interrupts.

BCTL - Bridge Control Register (0x03E)

Bit Field	Field Name	Type	Default Value	Description
0	PERRE	RW	0x0	Parity Error Response Enable. This bit controls the bridges response to poisoned TLPs on the secondary interface. 0x0 - (ignore) Ignore poisoned TLPs (i.e., parity errors) on the secondary interface. 0x1 - (report) Enable poisoned TLP (i.e., parity error) detection and reporting on the secondary interface of the bridge.

Notes

Bit Field	Field Name	Type	Default Value	Description
1	SERRE	RW	0x0	<p>System Error Enable. This bit controls forwarding of ERR_NONFATAL or ERR_FATAL from the secondary interface of the bridge to the primary interface.</p> <p>Note that error reporting must be enabled in the Command register or the PCI Express-specific bits are set in PCI Express Capability structure, Device Control register for errors to be reported on the primary interface.</p> <p>0x0 - (ignore) Do not forward errors from the secondary to the primary interface.</p> <p>0x1 - (report) Enable forwarding of errors from secondary to the primary interface.</p>
2	ISAEN	RW	0x0	<p>ISA Enable. This bit controls the routing of ISA I/O transactions.</p> <p>0 - (disable) Forward downstream all I/O addresses in the address range defined by the I/O base and I/O limit registers.</p> <p>1 - (enable) Forward upstream ISA I/O addresses in the address range defined by the I/O base and I/O limit registers that are in the first 64 KB of PCI I/O address space (top 768 bytes of each 1-KB block).</p>
3	VGAEN	RW	0x0	<p>VGA Enable. Controls the routing of processor-initiated transactions targeting VGA.</p> <p>0 - (block) Do not forward VGA compatible addresses from the primary interface to the secondary interface</p> <p>1 - (forward) Forward VGA compatible addresses from the primary to the secondary interface.</p>
4	VGA16EN	RW	0x0	<p>VGA 16-bit Enable. This bit only has an effect when the VGAEN bit is set in this register.</p> <p>This read/write bit enables system configuration software to select between 10-bit and 16-bit I/O space decoding for VGA transactions.</p> <p>0 - (bit10) Perform 10-bit decoding. I/O space aliasing occurs in this mode.</p> <p>1 - (bit16) Perform 16-bit decoding. No I/O space aliasing occurs in this mode.</p>
5	Reserved	RO	0x0	Reserved field.
6	SRESET	RW	0x0	<p>Secondary Bus Reset. Setting this bit triggers a secondary bus reset.</p> <p>In the upstream port, setting this bit initiates a upstream secondary bus reset.</p> <p>In a downstream port, setting this bit initiates a downstream secondary bus reset.</p>
15:7	Reserved	RO	0x0	Reserved field.

Notes

PCI Express Capability Structure

PCIECAP - PCI Express Capability (0x040)

Bit Field	Field Name	Type	Default Value	Description
7:0	CAPID	RO	0x10	Capability ID. The value of 0x10 identifies this capability as a PCI Express capability structure.
15:8	NXTPTR	RWL	0xC0	Next Pointer. This field contains a pointer to the next capability structure.
19:16	VER	RWL	0x1	PCI Express Capability Version. This field indicates the PCI-SIG defined PCI Express capability structure version number.
23:20	TYPE	RO	Upstream: 0x5 Downstream: 0x6	Port Type. This field identifies the type of switch port (upstream or downstream).
24	SLOT	RWL	0x0	Slot Implemented. This bit is set when the PCI Express link associated with this Port is connected to a slot. This field does not apply to an upstream port and should be set to zero.
29:25	IMN	RO	0x0	Interrupt Message Number. The function is allocated only one MSI. Therefore, this field is set to zero.
30	TCS	RWL	0x1	TCS Routing Supported. The PES3T3 supports TCS routing.
31	Reserved	RO	0x0	Reserved field.

PCIEDCAP - PCI Express Device Capabilities (0x044)

Bit Field	Field Name	Type	Default Value	Description
2:0	MPAYLOAD	RWL	HWINIT	Maximum Payload Size Supported. This field indicates the maximum payload size that the device can support for TLPs. The default value is 0x1 which corresponds to 256 Bytes.
4:3	PFS	RO	0x0	Phantom Functions Supported. This field indicates the support for unclaimed function number to extend the number of outstanding transactions allowed by logically combining unclaimed function numbers. The value is hardwired to 0x0 to indicate that no function number bits are used for phantom functions.
5	ETAG	RWL	0x1	Extended Tag Field Support. This field indicates the maximum supported size of the Tag field as a requester.
8:6	E0AL	RO	0x0	Endpoint L0s Acceptable Latency. This field indicates the acceptable total latency that an endpoint can withstand due to transition from the L0s state to the L0 state. The value is hardwired to 0x0 as this field does not apply to a switch.

Notes

Bit Field	Field Name	Type	Default Value	Description
11:9	E1AL	RO	0x0	Endpoint L1 Acceptable Latency. This field indicates the acceptable total latency that an endpoint can withstand due to transition from the L1 state to the L0 state. The value is hardwired to 0x0 as this field does not apply to a switch.
12	ABP	RO	0x0	Attention Button Present. In PCIe base 1.0a when set, this bit indicates that an Attention Button is implemented on the card/module. The value of this field is undefined in PCIe base 1.1.
13	AIP	RO	0x0	Attention Indicator Present. In PCIe base 1.0a when set, this bit indicates that an Attention Indicator is implemented on the card/module. The value of this field is undefined in PCIe base 1.1.
14	PIP	RO	0x0	Power Indicator Present. In PCIe base 1.0a when set, this bit indicates that a Power Indicator is implemented on the card/module. The value of this field is undefined in PCIe base 1.1.
15	RBERR	RO	0x1	Role Based Error Reporting. This bit is set to indicate that the PES3T3 supports error reporting as defined in the PCIe base 1.1 specification.
17:16	Reserved	RO	0x0	Reserved field.
25:18	CSPLV	RO	0x0	Captured Slot Power Limit Value. This field in combination with the Slot Power Limit Scale value, specifies the upper limit on power supplied by the slot. Power limit (in Watts) calculated by multiplying the value in this field by the value in the Slot Power Limit Scale field. The value of this field is set by a Set_Slot_Power_Limit Message and is only applicable for the upstream port. This field is always zero in downstream ports.
27:26	CSPLS	RO	0x0	Captured Slot Power Limit Scale. This field specifies the scale used for the Slot Power Limit Value. The value of this field is set by a Set_Slot_Power_Limit Message and is only applicable for the upstream port. This field is always zero in downstream ports. 0 - (v1) 1.0x 1 - (v1p1) 0.1x 2 - (v0p01) 0.01x 3 - (v0p001x) 0.001x
31:28	Reserved	RO	0x0	Reserved field.

PCIEDCTL - PCI Express Device Control (0x048)

Bit Field	Field Name	Type	Default Value	Description
0	CEREN	RW	0x0	Correctable Error Reporting Enable. This bit controls reporting of correctable errors.
1	NFEREN	RW	0x0	Non-Fatal Error Reporting Enable. This bit controls reporting of non-fatal errors.

Notes

Bit Field	Field Name	Type	Default Value	Description
2	FEREN	RW	0x0	Fatal Error Reporting Enable. This bit controls reporting of fatal errors.
3	URREN	RW	0x0	Unsupported Request Reporting Enable. This bit controls reporting of unsupported requests.
4	ERO	RO	0x0	Enable Relaxed Ordering. When set, this bit enables relaxed ordering. The switch never sets the relaxed ordering bit in transactions it initiates as a requester.
7:5	MPS	RW	0x0	Max Payload Size. This field sets maximum TLP payload size for the device. 0x0 - (s128) 128 bytes max payload size 0x1 - (s256) 256 bytes max payload size 0x2 - reserved (treated as 128 bytes) 0x3 - reserved (treated as 128 bytes) 0x4 - reserved (treated as 128 bytes) 0x5 - reserved (treated as 128 bytes) 0x6 - reserved (treated as 128 bytes) 0x7 - reserved (treated as 128 bytes)
8	ETFEN	RW	0x0	Extended Tag Field Enable. Since the bridge never generates a transaction that requires a completion, this bit has no functional effect on the device during normal operation. To aid in debug, when the SEQTAG field is set in the TLCTL register, this field controls whether tags are generated in the range from 0 through 31 or from 0 through 255.
9	PFEN	RO	0x0	Phantom Function Enable. The bridge does not support phantom function numbers. Therefore, this field is hardwired to zero.
10	AUXPMEN	RWS	0x0 FRSticky	Auxiliary Power PM Enable. The PES3T3 is enabled to draw AUX power independent of the PME AUX power. This is a sticky bit when AUX power is available and is not modified by hot, warm, or cold reset.
11	ENS	RO	0x0	Enable No Snoop. The bridge does not generate transactions with the No Snoop bit set and passes transactions through the bridge with the No Snoop bit unmodified.
14:12	MRRS	RO	0x0	Maximum Read Request Size. The bridge does not generate transactions larger than 128 bytes and passes transactions through the bridge with the size unmodified. Therefore, this field has no functional effect on the behavior of the bridge.
15	Reserved	RO	0x0	Reserved field.

PCIEDSTS - PCI Express Device Status (0x04A)

Bit Field	Field Name	Type	Default Value	Description
0	CED	RW1C	0x0	Correctable Error Detected. This bit indicates the status of correctable errors. Errors are logged in this register regardless of whether error reporting is enabled or not.

Notes

Bit Field	Field Name	Type	Default Value	Description
1	NFED	RW1C	0x0	Non-Fatal Error Detected. This bit indicates the status of correctable errors. Errors are logged in this register regardless of whether error reporting is enabled or not.
2	FED	RW1C	0x0	Fatal Error Detected. This bit indicates the status of Fatal errors. Errors are logged in this register regardless of whether error reporting is enabled or not.
3	URD	RW1C	0x0	Unsupported Request Detected. This bit indicates the device received an Unsupported Request. Errors are logged in this register regardless of whether error reporting is enabled or not.
4	AUXPD	RO	0x0	Aux Power Detected. The PES3T3 uses Auxiliary Power to support wakeup protocol. This bit is set when Auxiliary power is detected.
5	TP	RO	0x0	Transactions Pending. The bridge does not issue Non-Posted Requests on its own behalf. Therefore, this field is hardwired to zero.
15:6	Reserved	RO	0x0	Reserved field.

PCIELCAP - PCI Express Link Capabilities (0x04C)

Bit Field	Field Name	Type	Default Value	Description
3:0	MAXLNK-SPD	RO	0x1	Maximum Link Speed. This field indicates the supported link speeds of the port. 1 - (gen1) 2.5 Gbps 2 - (gen2) 5 Gbps others - reserved
9:4	MAXLNK-WDTH	RWL	HWINIT	Maximum Link Width. This field indicates the maximum link width of the given PCI Express link. For the upstream port, this field may be overridden to allow the link width to be forced to a smaller value. Setting this field to a invalid or reserved value results in x1 being used. The initial value of this field corresponds to the link width of the corresponding port. 0 - reserved 1 -(x1) x1 link width 2 -(x2) x2 link width 4 -(x4) x4 link width 8 - reserved 12 - reserved 16 - reserved 32 - reserved others - reserved
11:10	ASPMS	RO	0x3	Active State Power Management (ASPM) Support. This field is hardwired to 0x3 to indicate L0s and L1 Support.

Notes

Bit Field	Field Name	Type	Default Value	Description
14:12	LOSEL	RWL	see text	L0s Exit Latency. This field indicates the L0s exit latency for the given PCI Express link. This field depends on whether a common or separate reference clock is used. When separate clocks are used, 1 μ s to 2 μ s is reported with a read-only value of 0x5. When a common clock is used, 256 ns to 512 ns is reported with a read-only value of 0x3.
17:15	L1EL	RWL	0x2	L1 Exit Latency. This field indicates the L1 exit latency for the given PCI Express link. Transitioning from L1 to L0 always requires 2.3 μ s. Therefore, a value 2 μ s to less than 4 μ s is reported with a default value of 0x2.
18	CPM	RWL	0x0	Clock Power Management. This bit indicates if the component tolerates removal of the reference clock via the "CLKREQ#" mechanism. The PES3T3 does not support the removal of reference clocks.
19	SDERR	RWL	Upstream: 0x0 Downstream: 0x1	Surprise Down Error Reporting. The PES3T3 downstream ports support surprise down error reporting. This field does not apply to an upstream port and should be set to zero.
20	DLLLA	RWL	Upstream: 0x0 Downstream: 0x1	Data Link Layer Link Active Reporting. The PES3T3 downstream ports support the capability of reporting the DL_Active state of the data link control and management State machine. This field is not applicable for the upstream port and must be zero.
21	Reserved	RO	0x0	Reserved field.
23:22	Reserved	RO	0x0	Reserved field.
31:24	PORTNUM	RO	Port 0: 0x0 Port 2: 0x2 Port 3: 0x3	Port Number. This field indicates the PCI express port number for the corresponding link.

PCIELCTL - PCI Express Link Control (0x050)

Bit Field	Field Name	Type	Default Value	Description
1:0	ASPM	RW	0x0	Active State Power Management (ASPM) Control. This field controls the level of ASPM supported by the link. The initial value corresponds to disabled. The value contained in Serial EEPROM may override this default value 0x0 - (disabled) disabled 0x1 - (I0s) L0s enable entry 0x2 - (I1) L1 enable entry 0x3 - (I0sI1) L0s and L1 enable entry
2	Reserved	RO	0x0	Reserved field.
3	RCB	RO	0x0	Read Completion Boundary. This field is not applicable and is hardwired to zero.

Notes

Bit Field	Field Name	Type	Default Value	Description
4	LDIS	RW	0x0	Link Disable. When set in a downstream port, this bit disables the link. This bit is not applicable in the upstream port.
5	LRET	RW	0x0	Link Retrain. Writing a one to this field initiates Link retraining by directing the Physical Layer LTSSM to the Recovery state. This field always returns zero when read. It is permitted to set this bit while simultaneously modifying other fields in this register. When this is done, all modifications that affect link retraining are applied in the subsequent retraining. For compliance with the PCIe specification, this bit has no effect on the upstream port when the REGUNLOCK bit is cleared in the SWCTL register. In this mode the field is hard-wired to zero. When the REGUNLOCK bit is set, writing a one to the LRET bit initiates link retraining on the upstream port.
6	CCLK	RW	0x0	Common Clock Configuration. When set, this bit indicates that this component and the component at the opposite end of the link are operating with a distributed common reference clock.
7	ESYNC	RW	0x0	Extended Sync. When set, this bit forces transmission of additional ordered sets when exiting the L0s state and when in the recovery state.
8	CLKP-WRMGT	RO	0x0	Enable Clock Power Management. The PES3T3 does not support this feature.
15:9	Reserved	RO	0x0	Reserved field.

PCIELSTS - PCI Express Link Status (0x052)

Bit Field	Field Name	Type	Default Value	Description
3:0	LS	RO	0x1	Link Speed. This field indicates the current link speeds of the port. 1 - (gen1) 2.5 Gbps 2 - (gen2) 5 Gbps others - reserved
9:4	LW	RO	HWINIT	Link Width. This field indicates the negotiated width of the link.
10	TERR	RO	0x0	Training Error. In PCIe base 1.0a when set, this bit indicates that a link training error has occurred. The value of this field is undefined in PCIe base 1.1
11	LTRAIN	RO	0x0	Link Training. When set, this bit indicates that link training is in progress.

Notes

Bit Field	Field Name	Type	Default Value	Description
12	SCLK	RWL	HWINIT	Slot Clock Configuration. When set, this bit indicates that the component uses the same physical reference clock that the platform provides. The initial value of this field is the state of the CCLKUS signal for the upstream port and the CCLKDS signal for downstream ports. The serial EEPROM may override these default values.
13	DLLLA	RO	0x0	Data Link Layer Link Active. This bit indicates the status for the data link control and management state machine. 0x0 - (notactive) Data link layer not active state 0x1 - (active) Data link layer active state
15:14	Reserved	RO	0x0	Reserved field.

PCIESCAP - PCI Express Slot Capabilities (0x054)

Bit Field	Field Name	Type	Default Value	Description
0	ABP	RWL	0x0	Attention Button Present. This bit is set when the Attention Button is implemented for the port. This bit is read-only and has a value of zero when the SLOT bit in the PCIECAP register is cleared.
1	PCP	RWL	0x0	Power Control Present. This bit is set when a Power Controller is implemented for the port. This bit is read-only and has a value of zero when the SLOT bit in the PCIECAP register is cleared.
2	MRLP	RWL	0x0	MRL Sensor Present. This bit is set when an MRL Sensor is implemented for the port. This bit is read-only and has a value of zero when the SLOT bit in the PCIECAP register is cleared.
3	ATTIP	RWL	0x0	Attention Indicator Present. This bit is set when an Attention Indicator is implemented for the port. This bit is read-only and has a value of zero when the SLOT bit in the PCIECAP register is cleared.
4	PWRIP	RWL	0x0	Power Indicator Present. This bit is set when an Power Indicator is implemented for the port. This bit is read-only and has a value of zero when the SLOT bit in the PCIECAP register is cleared.
5	HPS	RWL	0x0	Hot Plug Surprise. When set, this bit indicates that a device present in the slot may be removed from the system without notice. This bit is read-only and has a value of zero when the SLOT bit in the PCIECAP register is cleared.
6	HPC	RWL	0x0	Hot Plug Capable. This bit is set if the slot corresponding to the port is capable of supporting hot-plug operations. This bit is read-only and has a value of zero when the SLOT bit in the PCIECAP register is cleared.

Notes

Bit Field	Field Name	Type	Default Value	Description
14:7	SPLV	RW	0x0	Slot Power Limit Value. In combination with the Slot Power Limit Scale, this field specifies the upper limit on power supplied by the slot. A Set_Slot_Power_Limit message is generated using this field whenever this register is written or when the link transitions from a non DL_Up status to a DL_Up status. This bit is read-only and has a value of zero when the SLOT bit in the PCIECAP register is cleared.
16:15	SPLS	RW	0x0	Slot Power Limit Scale. This field specifies the scale used for the Slot Power Limit Value (SPLV). 0x0 - (x1) 1.0x 0x1 - (xp1) 0.1x 0x2 - (xp01) 0.01x 0x3 - (xp001) 0.001x A Set_Slot_Power_Limit message is generated using this field whenever this register is written or when the link transitions from a non DL_Up status to a DL_Up status. This bit is read-only and has a value of zero when the SLOT bit in the PCIECAP register is cleared.
17	EIP	RWL	0x0	Electromechanical Interlock Present. This bit is set if an electromechanical interlock is implemented on the chassis for this slot. This bit is read-only and has a value of zero when the SLOT bit in the PCIECAP register is cleared.
18	NCCS	RO	0x0	No Command Completed Support. Software notification is always generated when an issued command is completed by the hot-plug controller. Therefore, this field is hardwired to zero.
31:19	PSLOTNUM	RWL	0x0	Physical Slot Number. This field indicates the physical slot number attached to this port. For devices interconnected on the system board, this field should be initialized to zero. This bit is read-only and has a value of zero when the SLOT bit in the PCIECAP register is cleared.

PCIESCTL - PCI Express Slot Control (0x058)

Bit Field	Field Name	Type	Default Value	Description
0	ABPE	RW	0x0	Attention Button Pressed Enable. This bit when set enables generation of a Hot-Plug interrupt or wake-up event on an attention button pressed event. This bit is read-only and has a value of zero when the corresponding capability is not enabled in the PCIESCAP register.
1	PFDE	RW	0x0	Power Fault Detected Enable. This bit when set enables the generation of a Hot-Plug interrupt or wake-up event on a power fault event. This bit is read-only and has a value of zero when the corresponding capability is not enabled in the PCIESCAP register.

Notes

Bit Field	Field Name	Type	Default Value	Description
2	MRLSCE	RW	0x0	MRL Sensor Change Enable. This bit when set enables the generation of a Hot-Plug interrupt or wake-up event on a MRL sensor change event. This bit is read-only and has a value of zero when the corresponding capability is not enabled in the PCIESCAP register.
3	PDCE	RW	0x0	Presence Detected Changed Enable. This bit when set enables the generation of a Hot-Plug interrupt or wake-up event on a presence detect change event.
4	CCIE	RW	0x0	Command Complete Interrupt Enable. This bit when set enables the generation of a Hot-Plug interrupt when a command is completed by the Hot-Plug Controller. This bit is read-only and has a value of zero when the corresponding capability is not enabled in the PCIESCAP register.
5	HPIE	RW	0x0	Hot Plug Interrupt Enable. This bit when set enables generation of a Hot-Plug interrupt on enabled Hot-Plug events. This bit is read-only and has a value of zero when the corresponding capability is not enabled in the PCIESCAP register.
7:6	AIC	RW	0x3	Attention Indicator Control. When read, this register returns the current state of the Attention Indicator. Writing to this register sets the indicator. This bit is read-only and has a value of zero when the corresponding capability is not enabled in the PCIESCAP register. This field is always zero if the ATTIP bit is cleared in the PCI-ESCAP register. 0x0 - (reserved) Reserved 0x1 - (on) On 0x2 - (blink) Blink 0x3 - (off) Off
9:8	PIC	RW	0x1	Power Indicator Control. When read, this register returns the current state of the Power Indicator. Writing to this register sets the indicator. This bit is read-only and has a value of zero when the corresponding capability is not enabled in the PCIESCAP register. This field is always zero if the PWRIP bit is cleared in the PCIESCAP register. 0x0 - (reserved) Reserved 0x1 - (on) On 0x2 - (blink) Blink 0x3 - (off) Off This field has no effect on the upstream port.
10	PCC	RW	0x0	Power Controller Control. When read, this register returns the current state of the power applied to the slot. Writing to this register sets the power state of the slot. This bit is read-only and has a value of zero when the corresponding capability is not enabled in the PCIESCAP register. 0x0 - (on) Power on 0x1 - (off) Power off

Notes

Bit Field	Field Name	Type	Default Value	Description
11	EIC	RW	0x0	Electromechanical Interlock Control. This field always returns a value of zero when read. If an electromechanical interlock is implemented, a write of a one to this field causes the state of the interlock to toggle and a write of a zero has no effect. This bit is read-only and has a value of zero when the corresponding capability is not enabled in the PCIESCAP register.
12	DLLLASCE	RW	0x0	Data Link Layer Link Active State Change Enable. This bit when set enables software notification when the Data Link Layer Link Active field is changed. When this bit is set, it results in generation of a Hot-Plug interrupt or wake-up event on a data link layer active field state change.
15:13	Reserved	RO	0x0	Reserved field.

PCIESSTS - PCI Express Slot Status (0x05A)

Bit Field	Field Name	Type	Default Value	Description
0	ABP	RW1C	0x0	Attention Button Pressed. Set when the attention button is pressed.
1	PFD	RW1C	0x0	Power Fault Detected. Set when the Power Controller detects a power fault.
2	MRLSC	RW1C	0x0	MRL Sensor Changed. Set when an MRL Sensor state change is detected.
3	PDC	RW1C	0x0	Presence Detected Changed. Set when a Presence Detected state change is detected.
4	CC	RW1C	0x0	Command Completed. This bit is set when the Hot-Plug Controller completes an issued command. If the bit is already set, then it remains set. A single write to the PCI Express Slot Control (PCIESCTL) register is considered to be a single command even if it affects more than one field in that register. This command completed bit is not set until processing of all actions associated with all fields in the PCIESCTL register have completed (i.e., all associated SMBus I/O expander transactions have completed).
5	MRLSS	RO	0x0	MRL Sensor State. This field enclosed the current state of the MRL sensor. 0x0 - (closed) MRL closed 0x1 - (open) MRL open
6	PDS	RO	0x1	Presence Detect State. This bit indicates the presence of a card in the slot corresponding to the port and reflects the state of the Presence Detect status. 0x0 - (empty) Slot empty 0x1 - (present) Card present

Notes

Bit Field	Field Name	Type	Default Value	Description
7	EIS	RO	0x0	Electromechanical Interlock Status. When an electromechanical interlock is implemented, this bit indicates the current status of the interlock. 0x0 - (disengaged) Electromechanical interlock disengaged 0x1 - (engaged) Electromechanical interlock engaged
8	DLLASC	RW1C	0x0	Data Link Layer Link Active State Change. This bit is set when the state of the data link layer active field in the link status register changes state. 0x0 - (nochange) No DLLLA state change 0x1 - (changed) DLLLA state change
15:9	Reserved	RO	0x0	Reserved field.

PCIEDCAP2 - PCI Express Device Capabilities 2 (0x064)

Bit Field	Field Name	Type	Default Value	Description
31:0	Reserved	RO	0x0	Reserved field.

PCIEDCTL2 - PCI Express Device Control 2 (0x068)

Bit Field	Field Name	Type	Default Value	Description
15:0	Reserved	RO	0x0	Reserved field.

PCIEDSTS2 - PCI Express Device Status 2 (0x06A)

Bit Field	Field Name	Type	Default Value	Description
15:0	Reserved	RO	0x0	Reserved field.

PCIELCAP2 - PCI Express Link Capabilities 2 (0x06C)

Bit Field	Field Name	Type	Default Value	Description
31:0	Reserved	RO	0x0	Reserved field.

PCIELCTL2 - PCI Express Link Control 2 (0x070)

Bit Field	Field Name	Type	Default Value	Description
15:0	Reserved	RO	0x0	Reserved field.

Notes

PCIELSTS2 - PCI Express Link Status 2 (0x072)

Bit Field	Field Name	Type	Default Value	Description
15:0	Reserved	RO	0x0	Reserved field.

PCIESCAP2 - PCI Express Slot Capabilities 2 (0x074)

Bit Field	Field Name	Type	Default Value	Description
31:0	Reserved	RO	0x0	Reserved field.

PCIESCTL2 - PCI Express Slot Control 2 (0x078)

Bit Field	Field Name	Type	Default Value	Description
15:0	Reserved	RO	0x0	Reserved field.

PCIESSTS2 - PCI Express Slot Status 2 (0x07A)

Bit Field	Field Name	Type	Default Value	Description
15:0	Reserved	RO	0x0	Reserved field.

Power Management Capability Structure

PMCAP - PCI Power Management Capabilities (0x0C0)

Bit Field	Field Name	Type	Default Value	Description
7:0	CAPID	RO	0x1	Capability ID. The value of 0x1 identifies this capability as a PCI power management capability structure.
15:8	NXTPTR	RWL	0xD0	Next Pointer. This field contains a pointer to the next capability structure. The value in this field is 0xD0 and points to the MSI capability structure.
18:16	VER	RO	0x3	Power Management Capability Version. This field indicates compliance with version two of the specification. Complies with version the PCI Bus Power Management Interface Specification, Revision 1.2.
19	PMECLK	RO	0x0	PME Clock. Does not apply to PCI Express.
20	Reserved	RO	0x0	Reserved field.
21	DEVSP	RWL	0x0	Device Specific Initialization. The value of zero indicates that no device specific initialization is required.

Notes

Bit Field	Field Name	Type	Default Value	Description
24:22	AUXI	RWS	0x7	AUX Current. This 3 bit field reports auxiliary current requirements by the function to retain PME Context when the main power rail is removed 0x0 - (self) Self Powered 0x1 - (55mA) Maximum current required is 55 mA 0x2 - (100mA) Maximum current required is 100 mA 0x3 - (160mA) Maximum current required is 160 mA 0x4 - (220mA) Maximum current required is 220 mA 0x5 - (270mA) Maximum current required is 270 mA 0x6 - (320mA) Maximum current required is 320 mA 0x7 - (375mA) Maximum current required is 375 mA
25	D1	RO	0x0	D1 Support. This field indicates that the PES3T3 does not support D1.
26	D2	RO	0x0	D2 Support. This field indicates that the PES3T3 does not support D2.
31:27	PME	RWS	0b11001	PME Support. This field indicates the power states in which the port may generate a PME. Bits 27, 30 and 31 are set to indicate that the bridge will forward PME messages.

PMCSR - PCI Power Management Control and Status (0x0C4)

Bit Field	Field Name	Type	Default Value	Description
1:0	PSTATE	RW	0x0	Power State. This field is used to determine the current power state and to set a new power state. 0x0 - (d0) D0 state 0x1 - (d1) D1 state (not supported by the PES3T3 and reserved) 0x2 - (d2) D2 state (not supported by the PES3T3 and reserved) 0x3 - (d3) D3 _{hot} state
2	Reserved	RO	0x0	Reserved field.
3	NOSOFRST	RWL	0x1	No Soft Reset. This bit indicates if the configuration context is preserved by the bridge when the device transitions from a D3 _{hot} to D0 power management state. 0x0 - (reset) State reset 0x1 - (preserved) State preserved
7:4	Reserved	RO	0x0	Reserved field.
8	PMEE	RWS	0x0 FRSticky	PME Enable. When this bit is set, PME message generation is enabled for the port. If a hot plug wakeup event is desired when exiting the D3 _{cold} state, then this bit should be set during serial EEPROM initialization. A hot reset does not result in modification of this field.
12:9	DSEL	RO	0x0	Data Select. The optional data register is not implemented.

Notes

Bit Field	Field Name	Type	Default Value	Description
14:13	DSCALE	RO	0x0	Data Scale. The optional data register is not implemented.
15	PMES	RW1C S	0x0 FRSticky	PME Status. This bit is set if a PME is generated by the port even if the PMEE bit is cleared. This bit is not set when the bridge is propagating a PME message but the port is not itself generating a PME. Since the upstream port never generates a PME, this bit will never be set in that port.
21:16	Reserved	RO	0x0	Reserved field.
22	B2B3	RO	0x0	B2/B3 Support. Does not apply to PCI Express.
23	BPCCE	RO	0x0	Bus Power/Clock Control Enable. Does not apply to PCI Express.
31:24	DATA	RO	0x0	Data. This optional field is not implemented.

Message Signaled Interrupt Capability Structure

MSICAP - Message Signaled Interrupt Capability and Control (0x0D0)

Bit Field	Field Name	Type	Default Value	Description
7:0	CAPID	RO	0x5	Capability ID. The value of 0x5 identifies this capability as a MSI capability structure.
15:8	NXTPTR	RWL	0x0	Next Pointer. This field contains a pointer to the next capability structure. This field is set to 0x0 indicating that it is the last capability.
16	EN	RW	0x0	Enable. This bit enables MSI. 0x0 - (disable) disabled 0x1 - (enable) enabled
19:17	MMC	RO	0x0	Multiple Message Capable. This field contains the number of requested messages.
22:20	MME	RW	0x0	Multiple Message Enable. Hardwired to one message.
23	A64	RO	0x1	64-bit Address Capable. The bridge is capable of generating messages using a 64-bit address.
31:24	Reserved	RO	0x0	Reserved field.

MSIADDR - Message Signaled Interrupt Address (0x0D4)

Bit Field	Field Name	Type	Default Value	Description
1:0	Reserved	RO	0x0	Reserved field.

Notes

Bit Field	Field Name	Type	Default Value	Description
31:2	ADDR	RW	0x0	Message Address. This field specifies the lower portion of the DWORD address of the MSI memory write transaction. The PES3T3 assumes that upstream and downstream ports generated MSIs are targeted to the root. Configuring the address contained in a port's MSIADDR and MSIADDRU registers to an address that does not route to the root port and subsequently generating an MSI produces undefined results.

MSIUADDR - Message Signaled Interrupt Upper Address (0x0D8)

Bit Field	Field Name	Type	Default Value	Description
31:0	UADDR	RW	0x0	Upper Message Address. This field specifies the upper portion of the DWORD address of the MSI memory write transaction. If the contents of this field are non-zero, then 64-bit address is used in the MSI memory write transaction. If the contents of this field are zero, then the 32-bit address specified in the MSIADDR field is used. The PES3T3 assumes that upstream and downstream ports generated MSIs are targeted to the root. Configuring the address contained in a port's MSIADDR and MSIADDRU registers to an address that does not route to the root port and subsequently generating an MSI produces undefined results.

MSIMDATA - Message Signaled Interrupt Message Data (0x0DC)

Bit Field	Field Name	Type	Default Value	Description
15:0	MDATA	RW	0x0	Message Data. This field contains the lower 16-bits of data that are written when a MSI is signalled.
31:16	Reserved	RO	0x0	Reserved field.

Subsystem ID and Subsystem Vendor ID

SSIDSSVIDCAP - Subsystem ID and Subsystem Vendor ID Capability (0x0F0)

Bit Field	Field Name	Type	Default Value	Description
7:0	CAPID	RO	0xD	Capability ID. The value of 0xD identifies this capability as a SSID/SSVID capability structure.
15:8	NXTPTR	RWL	0x00	Next Pointer. This field contains a pointer to the next capability structure.
31:16	Reserved	RO	0x0	Reserved field.

Notes

SSIDSSVID - Subsystem ID and Subsystem Vendor ID (0x0F4)

Bit Field	Field Name	Type	Default Value	Description
15:0	SSVID	RWL	0x0	SubSystem Vendor ID. This field identifies the manufacturer of the add-in card or subsystem. SSVID values are assigned by the PCI-SIG to insure uniqueness.
31:16	SSID	RWL	0x0	Subsystem ID. This field identifies the add-in card or subsystem. SSID values are assigned by the vendor.

Extended Configuration Space Access Registers

ECFGADDR - Extended Configuration Space Access Address (0x0F8)

Bit Field	Field Name	Type	Default Value	Description
1:0	Reserved	RO	0x0	Reserved field.
7:2	REG	RW	0x0	Register Number. This field selects the configuration register number as defined by Section 7.2.2 of the PCI Express Base Specification, Rev. 1.0a
11:8	EREG	RW	0x0	Extended Register Number. This field selects the extended configuration register number as defined by Section 7.2.2 of the PCI Express Base Specification, Rev. 1.0a
31:12	Reserved	RO	0x0	Reserved field.

ECFGDATA - Extended Configuration Space Access Data (0x0FC)

Bit Field	Field Name	Type	Default Value	Description
31:0	DATA	RW	0x0	Configuration Data. A read from this field will return the configuration space register value pointed to by the ECFGADDR register. A write to this field will update the contents of the configuration space register pointed to by the ECFGADDR register with the value written. For both reads and writes, the byte enables correspond to those used to access this field. When the ECFGADDR register points to the ECFGDATA register, then reads from ECFGDATA return zero and writes are ignored. When the ECFGADDR register points to itself, writes to the ECFGDATA register modify the contents of the ECFGADDR register. SMBus reads of this field return a value of zero and SMBus writes have no effect.

Notes

Advanced Error Reporting (AER) Enhanced Capability

AERCAP - AER Capabilities (0x100)

Bit Field	Field Name	Type	Default Value	Description
15:0	CAPID	RO	0x1	Capability ID. The value of 0x1 indicates an advanced error reporting capability structure.
19:16	CAPVER	RO	0x1	Capability Version. The value of 0x1. indicates compatibility with version 1 of the specification.
31:20	NXTPTR	RWL	0x200	Next Pointer.

AERUES - AER Uncorrectable Error Status (0x104)

Bit Field	Field Name	Type	Default Value	Description
0	UDEF	RW1C S	0x0 Sticky	Undefined. This bit is no longer used in this version of the specification.
3:1	Reserved	RO	0x0	Reserved field.
4	DLPERR	RW1C S	0x0 Sticky	Data Link Protocol Error Status. This bit is set when a data link layer protocol error is detected.
5	SDOENERR	RW1C S	0x0 Sticky	Surprise Down Error Status. This bit is set when a surprise down error is detected.
11:6	Reserved	RO	0x0 Sticky	Reserved field.
12	POISONED	RW1C S	0x0 Sticky	Poisoned TLP Status. This bit is set when a poisoned TLP is detected.
13	FCPERR	RW1C S	0x0 Sticky	Flow Control Protocol Error Status. This bit is set when a flow control protocol error is detected.
14	COMPTO	RO	0x0	Completion Time-out Status. A switch port does not initiate non-posted requests on its own behalf. Therefore, this field is hardwired to zero.
15	CABORT	RO	0x0	Completer Abort Status. The PES3T3 never responds to a non-posted request with a completer abort.
16	UECOMP	RW1C S	0x0 Sticky	Unexpected Completion Status. This bit is set when an unexpected completion is detected.
17	RCVOVR	RW1C S	0x0 Sticky	Receiver Overflow Status. This bit is set when a receiver overflow is detected.
18	MAL-FORMED	RW1C S	0x0 Sticky	Malformed TLP Status. This bit is set when a malformed TLP is detected.
19	ECRC	RW1C S	0x0 Sticky	ECRC Status. This bit is set when an ECRC error is detected.
20	UR	RW1C S	0x0 Sticky	UR Status. This bit is set when an unsupported request is detected.
31:21	Reserved	RO	0x0	Reserved field.

Notes

AERUEM - AER Uncorrectable Error Mask (0x108)

Bit Field	Field Name	Type	Default Value	Description
0	UDEF	RW	0x0 Sticky	Undefined. This bit is no longer used in this version of the specification.
3:1	Reserved	RO	0x0	Reserved field.
4	DLPERR	RWS	0x0 Sticky	Data Link Protocol Error Mask. When this bit is set, the corresponding bit in the AERUES register is masked. When a bit is masked in the AERUES register, the corresponding event is not logged in the advanced capability structure and an error is not reported to the root complex.
5	SDOENERR	RWS	0x0 Sticky	Surprise Down Error Status. When this bit is set, the corresponding bit in the AERUES register is masked. When a bit is masked in the AERUES register, the corresponding event is not logged in the advanced capability structure and an error is not reported to the root complex.
11:6	Reserved	RO	0x0	Reserved field.
12	POISONED	RWS	0x0 Sticky	Poisoned TLP Mask. When this bit is set, the corresponding bit in the AERUES register is masked. When a bit is masked in the AERUES register, the corresponding event is not logged in the advanced capability structure and an error is not reported to the root complex.
13	FCPERR	RWS	0x0 Sticky	Flow Control Protocol Error Mask. When this bit is set, the corresponding bit in the AERUES register is masked. When a bit is masked in the AERUES register, the corresponding event is not logged in the advanced capability structure and an error is not reported to the root complex.
14	COMPTO	RO	0x0	Completion Time-out Status. A switch port does not initiate non-posted requests on its own behalf. Therefore, this field is hardwired to zero.
15	CABORT	RO	0x0	Completer Abort Status. The PES3T3 never responds to a non-posted request with a completer abort.
16	UECOMP	RWS	0x0 Sticky	Unexpected Completion Mask. When this bit is set, the corresponding bit in the AERUES register is masked. When a bit is masked in the AERUES register, the corresponding event is not logged in the advanced capability structure and an error is not reported to the root complex.
17	RCVOVR	RWS	0x0 Sticky	Receiver Overflow Mask. When this bit is set, the corresponding bit in the AERUES register is masked. When a bit is masked in the AERUES register, the corresponding event is not logged in the advanced capability structure and an error is not reported to the root complex.
18	MAL-FORMED	RWS	0x0 Sticky	Malformed TLP Mask. When this bit is set, the corresponding bit in the AERUES register is masked. When a bit is masked in the AERUES register, the corresponding event is not logged in the advanced capability structure and an error is not reported to the root complex.

Notes

Bit Field	Field Name	Type	Default Value	Description
19	ECRC	RWS	0x0 Sticky	ECRC Mask. When this bit is set, the corresponding bit in the AERUES register is masked. When a bit is masked in the AERUES register, the corresponding event is not logged in the advanced capability structure and an error is not reported to the root complex.
20	UR	RWS	0x0 Sticky	UR Mask. When this bit is set, the corresponding bit in the AERUES register is masked. When a bit is masked in the AERUES register, the corresponding event is not logged in the advanced capability structure and an error is not reported to the root complex.
31:21	Reserved	RO	0x0	Reserved field.

AERUESV - AER Uncorrectable Error Severity (0x10C)

Bit Field	Field Name	Type	Default Value	Description
0	UDEF	RWS	0x0 Sticky	Undefined. This bit is no longer used in this version of the specification.
3:1	Reserved	RO	0x0	Reserved field.
4	DLPERR	RWS	0x1 Sticky	Data Link Protocol Error Severity. If the corresponding event is not masked in the AERUEM register, then when the event occurs, this bit controls the severity of the reported error. If this bit is set, the event is reported as a fatal error. When this bit is cleared, the event is reported as an uncorrectable error.
5	SDOENERR	RWS	0x1 Sticky	Surprise Down Error Status. If the corresponding event is not masked in the AERUEM register, then when the event occurs, this bit controls the severity of the reported error. If this bit is set, the event is reported as a fatal error. When this bit is cleared, the event is reported as an uncorrectable error.
11:6	Reserved	RO	0x0	Reserved field.
12	POISONED	RWS	0x0 Sticky	Poisoned TLP Status Severity. If the corresponding event is not masked in the AERUEM register, then when the event occurs, this bit controls the severity of the reported error. If this bit is set, the event is reported as a fatal error. When this bit is cleared, the event is reported as an uncorrectable error.
13	FCPERR	RWS	0x1 Sticky	Flow Control Protocol Error Severity. If the corresponding event is not masked in the AERUEM register, then when the event occurs, this bit controls the severity of the reported error. If this bit is set, the event is reported as a fatal error. When this bit is cleared, the event is reported as an uncorrectable error.
14	COMPTO	RO	0x0	Completion Time-out Status. A switch port does not initiate non-posted requests on its own behalf. Therefore, this field is hardwired to zero.
15	CABORT	RO	0x0	Completer Abort Status. The PES3T3 never responds to a non-posted request with a completer abort.

Notes

Bit Field	Field Name	Type	Default Value	Description
16	UECOMP	RWS	0x0 Sticky	Unexpected Completion Severity. If the corresponding event is not masked in the AERUEM register, then when the event occurs, this bit controls the severity of the reported error. If this bit is set, the event is reported as a fatal error. When this bit is cleared, the event is reported as an uncorrectable error.
17	RCVOVR	RWS	0x1 Sticky	Receiver Overflow Severity. If the corresponding event is not masked in the AERUEM register, then when the event occurs, this bit controls the severity of the reported error. If this bit is set, the event is reported as a fatal error. When this bit is cleared, the event is reported as an uncorrectable error.
18	MAL-FORMED	RWS	0x1 Sticky	Malformed TLP Severity. If the corresponding event is not masked in the AERUEM register, then when the event occurs, this bit controls the severity of the reported error. If this bit is set, the event is reported as a fatal error. When this bit is cleared, the event is reported as an uncorrectable error.
19	ECRC	RWS	0x0 Sticky	ECRC Severity. If the corresponding event is not masked in the AERUEM register, then when the event occurs, this bit controls the severity of the reported error. If this bit is set, the event is reported as a fatal error. When this bit is cleared, the event is reported as an uncorrectable error.
20	UR	RWS	0x0 Sticky	UR Severity. If the corresponding event is not masked in the AERUEM register, then when the event occurs, this bit controls the severity of the reported error. If this bit is set, the event is reported as a fatal error. When this bit is cleared, the event is reported as an uncorrectable error.
31:21	Reserved	RO	0x0	Reserved field.

AERCES - AER Correctable Error Status (0x110)

Bit Field	Field Name	Type	Default Value	Description
0	RCVERR	RW1C S	0x0 Sticky	Receiver Error Status. This bit is set when the physical layer detects a receiver error.
5:1	Reserved	RO	0x0	Reserved field.
6	BADTLP	RW1C S	0x0 Sticky	Bad TLP Status. This bit is set when a bad TLP is detected.
7	BADDLLP	RW1C S	0x0 Sticky	Bad DLLP Status. This bit is set when a bad DLLP is detected.
8	RPLYROVR	RW1C S	0x0 Sticky	Replay Number Rollover Status. This bit is set when a replay number rollover has occurred indicating that the data link layer has abandoned replays and has requested that the link be retrained.
11:9	Reserved	RO	0x0	Reserved field.
12	RPLYTO	RW1C S	0x0 Sticky	Replay Timer Time-Out Status. This bit is set when the replay timer in the data link layer times out.

Notes

Bit Field	Field Name	Type	Default Value	Description
13	ADVISO-RYNF	RW1C S	0x0 Sticky	Advisory Non-Fatal Error Status. This bit is set when an advisory non-fatal error is detected as described in Section 6.2.3.2.4 of the PCIe base 1.1 specification.
31:14	Reserved	RO	0x0	Reserved field.

AERCCEM - AER Correctable Error Mask (0x114)

Bit Field	Field Name	Type	Default Value	Description
0	RCVERR	RWS	0x0 Sticky	Receiver Error Mask. When this bit is set, the corresponding bit in the AERCES register is masked. When a bit is masked in the AERCES register, the corresponding event is not reported to the root complex.
5:1	Reserved	RO	0x0	Reserved field.
6	BADTLP	RWS	0x0 Sticky	Bad TLP Mask. When this bit is set, the corresponding bit in the AERCES register is masked. When a bit is masked in the AERCES register, the corresponding event is not reported to the root complex.
7	BADDLLP	RWS	0x0 Sticky	Bad DLLP Mask. When this bit is set, the corresponding bit in the AERCES register is masked. When a bit is masked in the AERCES register, the corresponding event is not reported to the root complex.
8	RPLYROVR	RWS	0x0 Sticky	Replay Number Rollover Mask. When this bit is set, the corresponding bit in the AERCES register is masked. When a bit is masked in the AERCES register, the corresponding event is not reported to the root complex.
11:9	Reserved	RO	0x0	Reserved field.
12	RPLYTO	RWS	0x0 Sticky	Replay Timer Time-Out Mask. When this bit is set, the corresponding bit in the AERCES register is masked. When a bit is masked in the AERCES register, the corresponding event is not reported to the root complex.
13	ADVISO-RYNF	RWS	0x1 Sticky	Advisory Non-Fatal Error Status. When this bit is set, the corresponding bit in the AERCES register is masked. When a bit is masked in the AERCES register, the corresponding event is not reported to the root complex.
31:14	Reserved	RO	0x0	Reserved field.

AERCTL - AER Control (0x118)

Bit Field	Field Name	Type	Default Value	Description
4:0	FEPTR	ROS	0x0 Sticky	First Error Pointer. This field contains a pointer to the bit in the AERUES register that resulted in the first reported error.
5	ECRCGC	RWL	0x1	ECRC Generation Capable. This bit indicates if the device is capable of generating ECRC.

Notes

Bit Field	Field Name	Type	Default Value	Description
6	ECRCGE	RWS	0x0 Sticky	ECRC Generation Enable. When this bit is set, ECRC generation is enabled.
7	ECRCCC	RWL	0x1	ECRC Check Capable. This bit indicates if the device is capable of checking ECRC.
8	ECRCCE	RWS	0x0 Sticky	ECRC Check Enable. When set, this bit enables ECRC checking.
31:9	Reserved	RO	0x0	Reserved field.

AERHL1DW - AER Header Log 1st Doubleword (0x11C)

Bit Field	Field Name	Type	Default Value	Description
31:0	HL	ROS	0x0 Sticky	Header Log. This field contains the 1st doubleword of the TLP header that resulted in the first reported uncorrectable error.

AERHL2DW - AER Header Log 2nd Doubleword (0x120)

Bit Field	Field Name	Type	Default Value	Description
31:0	HL	ROS	0x0 Sticky	Header Log. This field contains the 2nd doubleword of the TLP header that resulted in the first reported uncorrectable error.

AERHL3DW - AER Header Log 3rd Doubleword (0x124)

Bit Field	Field Name	Type	Default Value	Description
31:0	HL	ROS	0x0 Sticky	Header Log. This field contains the 3rd doubleword of the TLP header that resulted in the first reported uncorrectable error.

AERHL4DW - AER Header Log 4th Doubleword (0x128)

Bit Field	Field Name	Type	Default Value	Description
31:0	HL	ROS	0x0 Sticky	Header Log. This field contains the 4th doubleword of the TLP header that resulted in the first reported uncorrectable error.

Notes

Device Serial Number Enhanced Capability

SNUMCAP - Serial Number Capabilities (0x180)

Bit Field	Field Name	Type	Default Value	Description
15:0	CAPID	RO	0x3	Capability ID. The value of 0x3 indicates a device serial number capability structure.
19:16	CAPVER	RO	0x1	Capability Version. The value of 0x1. indicates compatibility with version 1 of the specification.
31:20	NXTPTR	RWL	0x0	Next Pointer.

SNUMLDW - Serial Number Lower Doubleword (0x184)

Bit Field	Field Name	Type	Default Value	Description
31:0	SNUM	RWL	0x0 Sticky	Lower 32-bits of Device Serial Number. This field contains the lower 32-bits of the IEEE defined 64-bit extended unique identifier (EUI-64) assigned to the device.

SNUMUDW - Serial Number Upper Doubleword (0x188)

Bit Field	Field Name	Type	Default Value	Description
31:0	SNUM	RWL	0x0 Sticky	Upper 32-bits of Device Serial Number. This field contains the upper 32-bits of the IEEE defined 64-bit extended unique identifier (EUI-64) assigned to the device.

PCI Express Virtual Channel Capability

PCIEVCECAP - PCI Express VC Enhanced Capability Header (0x200)

Bit Field	Field Name	Type	Default Value	Description
15:0	CAPID	RO	0x2	Capability ID. The value of 0x2. indicates a virtual channel capability structure.
19:16	CAPVER	RO	0x1	Capability Version. The value of 0x1. indicates compatibility with version 1 of the specification.
31:20	NXTPTR	RWL	0x0	Next Pointer. The value of 0x0 indicates that there are no extended capabilities.

PVCCAP1- Port VC Capability 1 (0x204)

Bit Field	Field Name	Type	Default Value	Description
2:0	EVCCNT	RO	0x0	Extended VC Count. The value 0x0 indicates only implementation of the default VC.

Notes

Bit Field	Field Name	Type	Default Value	Description
3	Reserved	RO	0x0	Reserved field.
6:4	LPEVCCNT	RO	0x0	Low Priority Extended VC Count. The value of 0x0 indicates only implementation of the default VC.
7	Reserved	RO	0x0	Reserved field.
9:8	REFCLK	RO	0x0	Reference Clock. Time-based WRR is not implemented.
11:10	PATBLSIZ	RO	Upstream: 0x2 Downstream: 0x0	Port Arbitration Table Entry Size. This field indicates the size of the port arbitration table in the device. For the upstream port, this is set to 0x2 to indicate a table with 4-bit entries. For downstream ports, this value is set to 0x0. 0x0 -(bit1) Port arbitration table is 1-bit 0x1 -(bit2) Port arbitration table is 2-bits 0x2 -(bit4) Port arbitration table is 4-bits 0x3 -(bit8) Port arbitration table is 8-bits
31:12	Reserved	RO	0x0	Reserved field.

PVCCAP2- Port VC Capability 2 (0x208)

Bit Field	Field Name	Type	Default Value	Description
7:0	VCARBCAP	RO	0x0	VC Arbitration Capability. This field indicates the type of VC arbitration that is supported by the port for the low priority VC group. This field is valid for all ports that report a low priority extended VC count greater than zero. Each bit in this field corresponds to a VC arbitration capability. bit 0 - hardware fixed arbitration (i.e., round robin) bit 1 - weighted round robin (WRR) with 32 phases bit 2 - weighted round robin (WRR) with 64 phases bit 3 - weighted round robin (WRR) with 128 phases bits 4 through 7 - reserved
23:8	Reserved	RO	0x0	Reserved field.
31:24	VCAT-BLOFF	RO	0x0	VC Arbitration Table Offset. This field contains the offset of the VC arbitration table from the base address of the Virtual Channel Capability structure in double quad words (16 bytes). The value of zero indicates that the VC arbitration table is not present.

Notes

PVCCTL - Port VC Control (0x20C)

Bit Field	Field Name	Type	Default Value	Description
0	LVCAT	RO	0x0	Load VC Arbitration Table. This bit, when set, updates the VC arbitration logic from the VC Arbitration Table for the VC resource. Since the device does not implement a VC arbitration table, this field has no functional effect. This bit always returns 0 when read.
3:1	VCARBSEL	RW	0x0	VC Arbitration Select. This field configures the VC arbitration by selecting of the supported arbitration schemes indicated by the VC arbitration capability field (i.e., the VCARBCAP field in the PVCCAP2 register). Since the device supports only VC0, this field has no functional effect.
15:4	Reserved	RO	0x0	Reserved field.

PVCSTS - Port VC Status (0x20E)

Bit Field	Field Name	Type	Default Value	Description
0	VCATS	RO	0x0	VC Arbitration Table Status. This bit indicates the coherency status of the VC arbitration table. Since the device supports only VC0, this field has no functional effect and is always zero.
15:1	Reserved	RO	0x0	Reserved field.

VCR0CAP- VC Resource 0 Capability (0x210)

Bit Field	Field Name	Type	Default Value	Description
7:0	PARBC	RO	Upstream: 0x3 Downstream: 0x1	Port Arbitration Capability. This field indicates the type of port arbitration supported by the VC. Each bit corresponds to a Port Arbitration capability. When more than one arbitration scheme is supported, multiple bits may be set. The upstream port supports hardware fixed round robin and weighted round robin with 32 phases. Downstream ports support only hardware fixed round robin. bit 0 - hardware fixed round robin bit 1 - weighted round robin with 32 phases bit 2 - weighted round robin with 64 phases bit 3 - weighted round robin with 128 phases bit 4 - time-based weighted round robin with 128 phases bit 5 - weighted round robin with 256 phases
13:8	Reserved	RO	0x0	Reserved field.
14	APS	RO	0x0	Advanced Packet Switching. Not supported.
15	RJST	RO	0x0	Reject Snoop Transactions. Not supported for switch ports.

Notes

Bit Field	Field Name	Type	Default Value	Description
22:16	MAXTS	RO	0x0	Maximum Time Slots. Since this VC does not support time-based WRR, this field is not valid.
23	Reserved	RO	0x0	Reserved field.
31:24	PATBLOFF	RO	Upstream: 0x2 Downstream: 0x0	Port Arbitration Table Offset. This field contains the offset of the port arbitration table from the base address of the Virtual Channel Capability structure in double quad words (16 bytes). The upstream port has a port arbitration table. Downstream ports do not have a port arbitration table.

VCR0CTL- VC Resource 0 Control (0x214)

Bit Field	Field Name	Type	Default Value	Description
7:0	TCVCMAP	bit 0 RO bits 1 through 7 RW	0xFF	TC/VC Map. This field indicates the TCs that are mapped to the VC resource. Each bit corresponds to a TC. When a bit is set, the corresponding TC is mapped to the VC.
15:8	Reserved	RO	0x0	Reserved field.
16	LPAT	RW	0x0	Load Port Arbitration Table. This bit, when set, updates the Port Arbitration logic from the Port Arbitration Table for the VC resource. In addition, this field is only valid when the Port Arbitration Table is used by the selected Port Arbitration scheme (that is indicated by a set bit in the Port Arbitration Capability field selected by Port Arbitration Select). Software sets this bit to signal hardware to update Port Arbitration logic with new values stored in Port Arbitration Table; clearing this bit has no effect. Software uses the Port Arbitration Table Status bit to confirm whether the new values of Port Arbitration Table are completely latched by the arbitration logic. This bit only has an effect in the upstream port. This bit always returns 0 when read.
19:17	PARBSEL	RW	0x0	Port Arbitration Select. This field configures the VC resource to provide a particular Port Arbitration service. The permissible values of this field is a number that corresponds to one of the asserted bits in the Port Arbitration Capability field of the VC resource.
23:20	Reserved	RO	0x0	Reserved field.
26:24	VCID	RO	0x0	VC ID. This field assigns a VC ID to the VC resource. Since the PES3T3 implements only a single VC, this field is hard-wired to zero.
30:27	Reserved	RO	0x0	Reserved field.

Notes

Bit Field	Field Name	Type	Default Value	Description
31	VCEN	RO	0x1	VC Enable. This field, when set, enables a virtual channel. Since the PES3T3 implements only a single VC, this field is hardwired to one (enabled).

VCR0STS - VC Resource 0 Status (0x218)

Bit Field	Field Name	Type	Default Value	Description
0	PATS	RO	0x0	Port Arbitration Table Status. This bit indicates the coherency status of the port arbitration table associated with the VC resource and is valid only when the port arbitration table is used by the selected arbitration algorithm. This bit is set when any entry of the port arbitration table is written by software and remains set until hardware finishes loading the value after software sets the LPAT field in the VCROCTL register. This field is always zero for downstream ports.
1	VCNEG	RO	0x0	VC Negotiation Pending. Since the PES3T3 implements only a single VC (i.e., the default VC) this field indicates the status of the process of flow control initialization.
31:2	Reserved	RO	0x0	Reserved field.

VCR0TBL0 - VC Resource 0 Arbitration Table Entry 0 (0x220)

Bit Field	Field Name	Type	Default Value	Description
3:0	PHASE0	RW	0x1	Phase 0. This field contains the port ID for the corresponding port arbitration period. Selecting an invalid port ID results in the entry being skipped without delay. The port arbitration behavior when this field contains an illegal value (i.e., reserved or the egress port ID) is undefined. 0x0 - (port_0) Port 0 (upstream port) 0x2 - (port_2) Port 2 0x3 - (port_3) Port 3 0x4 through 0xF - reserved
7:4	PHASE1	RW	0x2	Phase 1. This field contains the port ID for the corresponding port arbitration period.
11:8	PHASE2	RW	0x3	Phase 2. This field contains the port ID for the corresponding port arbitration period.
15:12	PHASE3	RW	0x4	Phase 3. This field contains the port ID for the corresponding port arbitration period.
19:16	PHASE4	RW	0x5	Phase 4. This field contains the port ID for the corresponding port arbitration period.
23:20	PHASE5	RW	0x6	Phase 5. This field contains the port ID for the corresponding port arbitration period.
27:24	PHASE6	RW	0x7	Phase 6. This field contains the port ID for the corresponding port arbitration period.

Notes

Bit Field	Field Name	Type	Default Value	Description
31:28	PHASE7	RW	0x1	Phase 7. This field contains the port ID for the corresponding port arbitration period.

VCR0TBL1 - VC Resource 0 Arbitration Table Entry 1 (0x224)

Bit Field	Field Name	Type	Default Value	Description
3:0	PHASE8	RW	0x2	Phase 8. This field contains the port ID for the corresponding port arbitration period.
7:4	PHASE9	RW	0x3	Phase 9. This field contains the port ID for the corresponding port arbitration period.
11:8	PHASE10	RW	0x4	Phase 10. This field contains the port ID for the corresponding port arbitration period.
15:12	PHASE11	RW	0x5	Phase 11. This field contains the port ID for the corresponding port arbitration period.
19:16	PHASE12	RW	0x6	Phase 12. This field contains the port ID for the corresponding port arbitration period.
23:20	PHASE13	RW	0x7	Phase 13. This field contains the port ID for the corresponding port arbitration period.
27:24	PHASE14	RW	0x1	Phase 14. This field contains the port ID for the corresponding port arbitration period.
31:28	PHASE15	RW	0x2	Phase 15. This field contains the port ID for the corresponding port arbitration period.

VCR0TBL2 - VC Resource 0 Arbitration Table Entry 2 (0x228)

Bit Field	Field Name	Type	Default Value	Description
3:0	PHASE16	RW	0x3	Phase 16. This field contains the port ID for the corresponding port arbitration period.
7:4	PHASE17	RW	0x4	Phase 17. This field contains the port ID for the corresponding port arbitration period.
11:8	PHASE18	RW	0x5	Phase 18. This field contains the port ID for the corresponding port arbitration period.
15:12	PHASE19	RW	0x6	Phase 19. This field contains the port ID for the corresponding port arbitration period.
19:16	PHASE20	RW	0x7	Phase 20. This field contains the port ID for the corresponding port arbitration period.
23:20	PHASE21	RW	0x1	Phase 21. This field contains the port ID for the corresponding port arbitration period.
27:24	PHASE22	RW	0x2	Phase 22. This field contains the port ID for the corresponding port arbitration period.

Notes

Bit Field	Field Name	Type	Default Value	Description
31:28	PHASE23	RW	0x3	Phase 23. This field contains the port ID for the corresponding port arbitration period.

VCR0TBL3 - VC Resource 0 Arbitration Table Entry 3 (0x22C)

Bit Field	Field Name	Type	Default Value	Description
3:0	PHASE24	RW	0x4	Phase 24. This field contains the port ID for the corresponding port arbitration period.
7:4	PHASE25	RW	0x5	Phase 25. This field contains the port ID for the corresponding port arbitration period.
11:8	PHASE26	RW	0x6	Phase 26. This field contains the port ID for the corresponding port arbitration period.
15:12	PHASE27	RW	0x7	Phase 27. This field contains the port ID for the corresponding port arbitration period.
19:16	PHASE28	RW	0x1	Phase 28. This field contains the port ID for the corresponding port arbitration period.
23:20	PHASE29	RW	0x2	Phase 29. This field contains the port ID for the corresponding port arbitration period.
27:24	PHASE30	RW	0x3	Phase 30. This field contains the port ID for the corresponding port arbitration period.
31:28	PHASE31	RW	0x4	Phase 31. This field contains the port ID for the corresponding port arbitration period.

Power Budgeting Enhanced Capability

PWRBCAP - Power Budgeting Capabilities (0x280)

Bit Field	Field Name	Type	Default Value	Description
15:0	CAPID	RWL	0x0	Capability ID. The value of 0x4 indicates a power budgeting capability structure. If the power budgeting capability is used, then this field should be initialized with data from a serial EEPROM.
19:16	CAPVER	RWL	0x0	Capability Version. The value of 0x1. indicates compatibility with version 1 of the specification. If the power budgeting capability is used, then this field should be initialized with data from a serial EEPROM.
31:20	NXTPTR	RWL	0x0	Next Pointer.

Notes

PWRBDSEL - Power Budgeting Data Select (0x284)

Bit Field	Field Name	Type	Default Value	Description
7:0	DVSEL	RW	0x0	Data Value Select. This field selects the Power Budgeting Data Value (PWRBDVx) register whose contents are reported in the Data (DATA) field of the Power Budgeting Data (PWRBD) register. Setting this field to a value greater than 9, causes zero to be returned in the DATA field of the PWRBD register.
31:8	Reserved	RO	0x0	Reserved field.

PWRBD - Power Budgeting Data (0x288)

Bit Field	Field Name	Type	Default Value	Description
31:0	DATA	RO	0x0	Data. If the Data Value Select (DVSEL) field in the Power Budgeting Data Select register contains a value of zero through 31, then this field returns the contents of the corresponding Power Budgeting Data Value (PWRBDVx) register. Otherwise, this field contains a value of zero.

PWRBPBC - Power Budgeting Power Budget Capability (0x28C)

Bit Field	Field Name	Type	Default Value	Description
0	SA	RWL	0x0 Sticky	System Allocated. When this bit is set, it indicates that the power budget for the device is included within the system power budget and that reported power data for this device should be ignored. If the power budgeting capability is used, then this field should be initialized with data from a serial EEPROM.
31:1	Reserved	RO	0x0	Reserved field.

PWRBDV[9:0] - Power Budgeting Data Value [9:0] (0x300)

Bit Field	Field Name	Type	Default Value	Description
31:0	DV	RWL	Undefined Sticky	Data Value. This 32-bit field is used to hold power budget data in the format described in Section 7.15.3 in the PCIe 1.1 Base Specification. This field may be read and written when the Power Budgeting Data Value Unlock (PWRBDVUL) bit is set in the System Control (SYSCTL) register. When the PWRBDVUL bit is cleared, this register is read-only and writes are ignored. If the power budgeting capability is used, then this field should be initialized with data from a serial EEPROM.

Notes

Switch Control and Status Registers

SWSTS - Switch Status (0x328)

Bit Field	Field Name	Type	Default Value	Description
2:0	SWMODE	RO	HWINIT	Switch Mode. These configuration pins determine the PES3T3 switch operating mode. 0x0 - Normal switch mode 0x1 - Normal switch mode with Serial EEPROM initialization 0x2 - through 0xF Reserve
4:3	Reserved	RO	0x0	Reserved field.
5	CCLKDS	RO	HWINIT	Common Clock Downstream. This bit reflects the value of the CCLKDS signal sampled during the fundamental reset.
6	CCLKUS	RO	HWINIT	Common Clock Upstream. This bit reflects the value of the CCLKUS signal sampled during the fundamental reset.
7	Reserved	RO	0x0	Reserved field.
8	Reserved	RO	0x0	Reserved field.
9	RSTHALT	RO	HWINIT	Reset Halt. This bit reflects the value of the RSTHALT signal sampled during the fundamental reset.
19:10	Reserved	RO	0x0	Reserved field.
22:20	LOCKMODE	RO	0x0	Lock Mode. This field reflects the current locked status of the switch. 0x0 - (unlocked) Upstream port is unlocked 0x1 - (reserved) 0x2 - (port2locked) Upstream port is locked with port 2. 0x3 - (port3locked) Upstream port is locked with port 3. 0x4 through 0x7 - Reserved
27:23	Reserved	RO	0x0	Reserved field.
31:28	MARKER	RWL	0x0 Sticky	Marker. This field is preserved across a hot reset and is available for general software use. A hot reset does not result in modification of this field.

SWCTL - Switch Control (0x32C)

Bit Field	Field Name	Type	Default Value	Description
0	FRST	RW	0x0	Fundamental Reset. Writing a one to this bit initiates a fundamental reset. Writing a zero has no effect. This field always returns a value of zero when read. See section Fundamental Reset on page 2-5 for the behavior of this bit.
1	HRST	RW	0x0	Hot Reset. Writing a one to this bit initiates a hot reset. Writing a zero has no effect. This field always returns a value of zero when read. See section Hot Reset on page 2-6 for the behavior of this bit.

Notes

Bit Field	Field Name	Type	Default Value	Description
2	RSTHALT	RW	HWINIT Sticky	Reset Halt. When this bit is set, all of the switch logic except the SMBus interface remains in a reset state. When this bit is cleared, normal operation ensues. Setting or clearing this bit has no effect following a reset operation. This bit will be set if during serial EEPROM initialization an error is detected or it may be intentionally set by the user through the EEPROM code.
3	REGUN- LOCK	RW	0x0 Sticky	Register Unlock. When this bit is set, the contents of registers and fields of type Read and Write when Unlocked (RWL) are modified when written to. When this bit is cleared, all registers and fields denoted as RWL become read-only. While the initial value of this field is cleared, it is set during a reset operation, thus allowing serial EEPROM initialization to modify the contents of RWL fields.
4	PWRBDVUL	RWL	0x0 Sticky	Power Budgeting Data Value Unlock. When this bit is set, the Power Budgeting Data Value [9:0] (PWRBDV[9:0]) registers in all ports may be read and written. When this bit is cleared, then the PWRBDV registers in all ports are read-only.
5	DLDRST	RW	0x0 Sticky	Disable Link Down Hot Reset. When this bit is set, hot resets due to the data link layer of the upstream port transitioning to the DL_Down state are disabled. All other hot reset conditions are unaffected by this bit.
6	DHRSTSEI	RW	0x0 Sticky	Disable Hot Reset Serial EEPROM Initialization. When this bit is set, step 6 "serial EEPROM initialization" is skipped in the hot reset sequence described in section Hot Reset on page 2-6 regardless of the selected switch operating mode.
7	DRO	RW	0x0 Sticky	Disable Relaxed Ordering. The switch implements relaxed ordering for TLPs with the relaxed ordering bit set. When the DRO bit is set, the switch strongly orders all transactions regardless of the state of the relaxed ordering bit in TLPs.
8	DP2P	RW	0x0 Sticky	Disable Peer-to-Peer Transactions. When this bit is set, all peer-to-peer transactions are disabled. In this mode, transactions received on a downstream port which are not destined to the upstream port are treated as an unsupported requests.
13:9	Reserved			Reserved field.
14	CTDIS	RW	0x0 Sticky	Disable Cut-Through Routing. When this bit is set, cut through routing of TLPs is disabled between all ports (i.e., they are routed in a stored and forwarded manner). When this bit is cleared, TLPs are routed in a cut-through manner when possible.
15	LOCKI- GNORE	RW	0x0 Sticky	Ignore Locked Transactions When this bit is set, all bus locking side-effects associated with locked transactions (e.g., MRdLk) are ignored and the TLPs are treated by the PES3T3 as normal TLPs (e.g., are routed normally through the switch).

Notes

Bit Field	Field Name	Type	Default Value	Description
16	WAKEDIR	RWS	0x0 FRSticky	Wake Signal Direction. This bit field decides the direction of the WAKEN signal. When the Vaux power is turned on, this bit field is set to 0x0. 0x0 - (input) WAKEN signal is an input 0x1 - (output) WAKEN signal is an output
17	APWREN	RWS	PORHWINIT FRSticky	Auxiliary Power Enable. This field is used to enable or disable use of the auxiliary power. This bit is initialized at the time of Power on Reset (Vaux power turn on) by inverse of the signal input on APWRDISN pin. 0x0 - (disable) Device is disabled to use auxiliary power 0x1 - (enable) Device is enabled to use auxiliary power
18	BDISCARD	RW	0x0 Sticky	Discard Vendor defined Broadcast packets. When this bit is set, the PES3T3 discards vendor defined broadcast messages coming on the upstream port.
31:17	Reserved	RO	0x0	Reserved field.

HPCFGCTL - Hot-Plug Configuration Control (0x330)

Bit Field	Field Name	Type	Default Value	Description
0	IPXAPN	RW	0x0 Sticky	Invert Polarity of PxAPN. When this bit is set, the polarity of the PxAPN input is inverted in all ports.
1	IPXPDN	RW	0x0 Sticky	Invert Polarity of PxPDN. When this bit is set, the polarity of the PxPDN input is inverted in all ports.
2	IPXPFN	RW	0x0 Sticky	Invert Polarity of PxPFN. When this bit is set, the polarity of the PxPFN input is inverted in all ports.
3	IPXMRLN	RW	0x0 Sticky	Invert Polarity of PxMRLN. When this bit is set, the polarity of the PxMRLN input is inverted in all ports.
4	IPXAIN	RW	0x0 Sticky	Invert Polarity of PxAIN. When this bit is set, the polarity of the PxAIN output is inverted in all ports.
5	IPXPIN	RW	0x0 Sticky	Invert Polarity of PxPIN. When this bit is set, the polarity of the PxPIN output is inverted in all ports.
6	IPXPEP	RW	0x0 Sticky	Invert Polarity of PxPEP. When this bit is set, the polarity of the PxPEP output is inverted in all ports.
7	IPXLOCKP	RW	0x0 Sticky	Invert Polarity of PxLOCKP. When this bit is set, the polarity of the PxLOCKP output is inverted in all ports.
8	IPXP- WRGDN	RW	0x0 Sticky	Invert Polarity of PxPWRGDN. When this bit is set, the polarity of the PxPWRGDN input is inverted in all ports.
10:9	Reserved	RO	0x0	Reserved.

Notes

Bit Field	Field Name	Type	Default Value	Description
11	MRLP-WROFF	RW	0x1 Sticky	MRL Automatic Power Off. When this bit is set and the Manual Retention Latch Present (MRLP) bit is set in the PCI Express Slot Capability (PCIESCAP) register, then power to the slot is automatically turned off when the MRL sensor indicates that the MRL is open. This occurs regardless of the state of the Power Controller Control (PCC) bit in the PCI Express Slot Control (PCIESCTL) register.
12	RMRL-WEMIL	RW	0x0 Sticky	Replace MRL Status with EMIL Status. When this bit is set, the PxMRLN signal inputs are used as electromechanical lock state inputs.
13	TEMICTL	RW	0x0 Sticky	Toggle Electromechanical Interlock Control. When this bit is cleared, the Electromechanical Interlock (PxILOCKP) output is pulsed for 125 mS when a one is written to the EIC bit in the PCIESCTL register. When this bit is set, writing a one to the EIC register inverts the state of the PxILOCKP output.
15:14	RSTMODE	RW	0x0 Sticky	Reset Mode. This field controls the manner in which downstream port reset outputs are generated. 0x0 - (pec) Power enable controlled reset output 0x1 - (pgc) Power good controlled reset output 0x2 - (hot) Hot reset controlled reset output 0x3 - reserved
23:16	PWR2RST	RW	0x14 Sticky	Slot Power to Reset Negation. This field contains the delay from stable downstream port power to negation of the downstream port reset in units of 10 mS. A value of zero corresponds to no delay. This field may be used to meet the T_{PCPERL} specification. The default value corresponds to 200 mS.
31:24	RST2PWR	RW	0x14 Sticky	Reset Negation. This field contains the delay from negation of a downstream port's reset to disabling of a downstream port's power in units of 10 mS. A value of zero corresponds to no delay. The default value corresponds to 200 mS.

GPR - General Purpose Register (0x334)

Bit Field	Field Name	Type	Default Value	Description
31:0	DATA	RW	0x0	Data. General purpose register available for software use.

Notes

GPIOFUNC - General Purpose I/O Control Function (0x338)

Bit Field	Field Name	Type	Default Value	Description
15:0	GPIOFUNC	RW	0x0 Sticky	GPIO Function. Each bit in this field controls the corresponding GPIO pin. When set to a one, the corresponding GPIO pin operates as the alternate function as defined in Chapter 5, General Purpose Inputs/Outputs. When a bit is cleared to a zero, the corresponding GPIO pin operates as a general purpose I/O pin.
31:16	Reserved	RO	0x0	Reserved field.

GPIOCFG - General Purpose I/O Configuration (0x33C)

Bit Field	Field Name	Type	Default Value	Description
15:0	GPIOCFG	RW	0x0 Sticky	GPIO Configuration. Each bit in this field controls the corresponding GPIO pin. When a bit is configured as a general purpose I/O pin and the corresponding bit in this field is set, then the pin is configured as a GPIO output. When a bit is configured as a general purpose I/O pin and the corresponding bit in this field is zero, then the pin is configured as an input. When the pin is configured as an alternate function, the behavior of the pin is defined by the alternate function.
31:16	Reserved	RO	0x0	Reserved field.

GPIOD - General Purpose I/O Data (0x340)

Bit Field	Field Name	Type	Default Value	Description
15:0	GPIOD	RW	HWINIT Sticky	GPIO Data. Each bit in this field controls the corresponding GPIO pin. Reading this field returns the current value of each GPIO pin regardless of GPIO pin mode (i.e., alternate function or GPIO pin). Writing a value to this field causes the corresponding pins which are configured as GPIO outputs to change state to the value written.
31:16	Reserved	RO	0x0	Reserved field.

SMBUSSTS - SMBus Status (0x344)

Bit Field	Field Name	Type	Default Value	Description
23:0	Reserved	RO	0x0	Reserved field.
24	EEPROM-DONE	RO	0x0	Serial EEPROM Initialization Done. When the switch is configured to operate in a mode in which serial EEPROM initialization occurs during a fundamental reset, this bit is set when serial EEPROM initialization completes or when an error is detected.

Notes

Bit Field	Field Name	Type	Default Value	Description
25	NAERR	RW1C	0x0	No Acknowledge Error. This bit is set if an unexpected NACK is observed during a master SMBus transaction. The setting of this bit may indicate the following: that the addressed device does not exist on the SMBus (i.e., addressing error); data is unavailable or the device is busy.
26	LAERR	RW1C	0x0	Lost Arbitration Error. When the master SMBus interface loses arbitration for the SMBus, it automatically re-arbitrates for the SMBus. If the master SMBus interface loses 16 consecutive arbitration attempts, then the transaction is aborted and this bit is set.
27	OTHERERR	RW1C	0x0	Other Error. This bit is set if a misplaced START or STOP condition is detected by the master SMBus interface.
28	ICSERR	RW1C	0x0	Initialization Checksum Error. This bit is set if an invalid checksum is computed during Serial EEPROM initialization or when a configuration done command is not found in the serial EEPROM.
29	URIA	RW1C	0x0	Unmapped Register Initialization Attempt. This bit is set if an attempt is made to initialize via serial EEPROM a register that is not defined in the corresponding PCI configuration space.
31:30	Reserved	RO	0x0	Reserved field.

SMBUSCTL - SMBus Control (0x348)

Bit Field	Field Name	Type	Default Value	Description
15:0	MSMBCP	RW	HWINIT Sticky	Master SMBus Clock Prescaler. This field contains a clock prescaler value used during master SMBus transactions. The prescaler clock period is equal to 32 ns multiplied by the value in this field. When the field is cleared to zero or one, the clock is stopped. The value of this field is 0x0139 as the master SMBus is configured to operate at 100 KHz in the boot configuration.
16	MSMBIOM	RW	0x0 Sticky	Master SMBus Ignore Other Masters. When this bit is set, the master SMBus proceeds with transactions regardless of whether it won or lost arbitration.
17	ICHECK-SUM	RW	0x0 Sticky	Ignore Checksum Errors. When this bit is set, serial EEPROM initialization checksum errors are ignored (i.e., the checksum always passes).
21:18	Reserved	RO	0x0	Reserved field.
22	SMBDTO	RW	0x0	SMBus Disable Time-out. When this bit is set, SMBus time-outs are disabled on the master SMBus.
31:23	Reserved	RO	0x0	Reserved field.

Notes

EEPROMINTF - Serial EEPROM Interface (0x34C)

Bit Field	Field Name	Type	Default Value	Description
15:0	ADDR	RW	0x0	EEPROM Address. This field contains the byte address in the Serial EEPROM to be read or written.
23:16	DATA	RW	0x0	EEPROM Data. A write to this field will initiate a serial EEPROM read or write operation, as selected by the OP field, to the address specified in the ADDR field. When a write operation is selected, the value written to this field is the value written to the serial EEPROM. When a read operation is selected, the value written to this field is ignored and the value read from the serial EEPROM may be read from this field when the DONE bit is set.
24	BUSY	RO	0x0	EEPROM Busy. This bit is set when a serial EEPROM read or write operation is in progress. 0x0 - (idle) serial EEPROM interface idle 0x1 - (busy) serial EEPROM interface operation in progress
25	DONE	RW1C	0x0	EEPROM Operation Completed. This bit is set when a serial EEPROM operation has completed. 0x0 - (notdone) interface is idle or operation in progress 0x1 - (done) operation completed
26	OP	RW	0x0	EEPROM Operation Select. This field selects the type of EEPROM operation to be performed when the DATA field is written 0x0 - (write) serial EEPROM write 0x1 - (read) serial EEPROM read
31:27	Reserved	RO	0x0	Reserved field.

IOEXPINTF - I/O Expander Interface (0x350)

Bit Field	Field Name	Type	Default Value	Description
15:0	IOEDATA	RW	0x0	I/O Expander Data. Each bit in this field corresponds to an I/O expander input/output signal. Reading this field returns the current value of the corresponding I/O pin state of the I/O expander number selected in the Select (SEL) field in this register (i.e., the input values last read from the I/O expander and output values supplied to the I/O expander). Writes to this field are ignored unless the I/O Expander Test Mode (IOEXTM) bit is set. When the IOEXTM bit is set, the value for outputs supplied to the I/O expander selected by the SEL field correspond to the value written to this field instead of the value supplied by internal logic. Bits in this field which correspond to inputs are always read-only, even when the IOEXTM bit is set.
23:16	Reserved	RO	0x0	Reserved field.
24	RELOADIOEX	RW	0x0	Reload I/O Expander Signals. Writing a one to this field results in an I/O expander SMBus transaction that refreshes all I/O expander input and output signal values in the IOEDATA field. This bit always returns a zero when read.

Notes

Bit Field	Field Name	Type	Default Value	Description
25	IOEXTM	RW	0x0	IO Expander Test Mode. Setting this bit puts the I/O expander interface into a test mode. In this test mode, I/O expander output signals generated by the PES3T3 core are ignored and values supplied to the I/O expander correspond to value written to the IOEDATA field.
29:26	SELECT	RW	0x0	I/O Expander Select. This field selects the I/O expander on which fields in this register operate. 0x0 - (ioe0) I/O expander 0 0x1 - (ioe1) I/O expander 1 0x2 - (ioe2) I/O expander 2 0x3 - reserved 0x4 - (ioe4) I/O expander 4 0x5 through 0x7 - reserved
30	Reserved	RO	0x0	Reserved field.
31	DONE	RW1C	0x0	I/O Expander Operation Done. This bit is set when any of the following conditions occur. RELOADIOEX bit in this register is written, the corresponding I/O expander is selected by the SELECT field in this register, and the corresponding IO expander SMBus transaction completes. The I/O expander is in test mode (i.e., IOEXTM bit set), the IOEDATA field is written, the corresponding I/O expander is selected by the SELECT field in this register, and the corresponding IO expander SMBus transaction updating the I/O expander outputs completes. An I/O Expander Address (IOExADDR) field is written in an SMBus I/O Expander Address (IOEXPADRY) register, the corresponding I/O expander is selected by the SELECT field in this register, and the I/O expander initialization sequence completes.

IOEXPADDR0 - SMBus I/O Expander Address 0 (0x354)

Bit Field	Field Name	Type	Default Value	Description
0	Reserved	RO	0x0	Reserved field.
7:1	IOE0ADDR	RWL	0x0 Sticky	I/O Expander 0 Address. This field contains the SMBus address assigned to I/O expander 0 on the master SMBus interface.
8	Reserved	RO	0x0	Reserved field.
15:9	IOE1ADDR	RWL	0x0 Sticky	I/O Expander 1 Address. This field contains the SMBus address assigned to I/O expander 1 on the master SMBus interface.
16	Reserved	RO	0x0	Reserved field.
23:17	IOE2ADDR	RWL	0x0 Sticky	I/O Expander 2 Address. This field contains the SMBus address assigned to I/O expander 2 on the master SMBus interface.
31:24	Reserved	RO	0x0	Reserved field.

Notes

IOEXPADDR1 - SMBus I/O Expander Address 1 (0x358)

Bit Field	Field Name	Type	Default Value	Description
0	Reserved	RO	0x0	Reserved field.
7:1	IOE4ADDR	RWL	0x0 Sticky	I/O Expander 4 Address. This field contains the SMBus address assigned to I/O expander 4 on the master SMBus interface.
31:0	Reserved	RO	0x0	Reserved field.

GPECTL - General Purpose Event Control (0x35C)

Bit Field	Field Name	Type	Default Value	Description
0	IGPE	RW	0x0 Sticky	Invert General Purpose Event Enable Signal Polarity. When this bit is set, the polarity of all General Purpose Event (GPEN) signals is inverted. 0x0 - (normal) GPEN signals are active low 0x1 - (invert) GPEN signals are active high
1	Reserved	RO	0x0	Reserved field.
2	P2GPEE	RW	0x0 Sticky	Port 2 General Purpose Event Enable. When this bit is set, the hot-plug INTx, MSI and PME event notification mechanisms defined by the PCIe base 1.1 specification are disabled for port 2 and are instead signalled through General Purpose Event (GPEN) signal assertions. GPEN is an alternate function of GPIO[7].
3	P3GPEE	RW	0x0 Sticky	Port 3 General Purpose Event Enable. When this bit is set, the hot-plug INTx, MSI and PME event notification mechanisms defined by the PCIe base 1.1 specification are disabled for port 3 and are instead signalled through General Purpose Event (GPEN) signal assertions. GPEN is an alternate function of GPIO[7].
31:4	Reserved	RO	0x0	Reserved field.

GPESTS - General Purpose Event Status (0x360)

Bit Field	Field Name	Type	Default Value	Description
0	Reserved	RO	0x0	Reserved field.
1	P2GPES	RO	0x0	Port 2 General Purpose Event Status. When this bit is set, the corresponding port is signalling a general purpose event by asserting the GPEN signal. This bit is never set if the corresponding general purpose event is not enabled in the GPECTL register. GPEN is an alternate function of GPIO[7] and GPIO[7] is asserted only if enabled to operate as an alternate function.

Notes

Bit Field	Field Name	Type	Default Value	Description
2	P3GPES	RO	0x0	Port 3 General Purpose Event Status. When this bit is set, the corresponding port is signalling a general purpose event by asserting the GPEN signal. This bit is never set if the corresponding general purpose event is not enabled in the GPECTL register. GPEN is an alternate function of GPIO[7] and GPIO[7] is asserted only if enabled to operate as an alternate function.
31:3	Reserved	RO	0x0	Reserved field.

Internal Switch Error Control and Status Registers

SWPECTL - Switch Parity Error Control (0x4D4)

Bit Field	Field Name	Type	Default Value	Description
0	DEEPC	RW	0x0 Sticky	Disable End-to-End Parity Checking. When this bit is set, end-to-end parity is not checked by the port and errors are never generated. End-to-end parity is always computed for data sent by the port to the switch core and cannot be disabled.
1	GBEEP	RW	0x0 Sticky	Generate Bad End-to-End Parity. When this bit is set, bad parity is generated for all double words in TLPs emitted to the switch core from this port (i.e., those received on the ingress port or generated by the port) whose TLP header length field (i.e., bits seven through zero of byte zero of the TLP header) match the value in the Error Match Length (Length) field in this register
7:2	Reserved	RO	0x0	Reserved field.
15:8	LENGTH	RW	0x0 Sticky	Error Match Length. When the GBEEP bit is set, bad parity is generated for all double words in TLPs emitted to the switch core from this port (i.e., those received on the ingress port or generated by the stack) whose TLP header length field (i.e., bits seven through zero of byte zero of the TLP header) matches the value in this field.
31:16	Reserved	RO	0x0	Reserved field.

SWERRSTS - Switch Internal Error Status (0x4D8)

Bit Field	Field Name	Type	Default Value	Description
0	EEPE	RW1C	0x0	End-to-End Parity Error. This bit is set when an end-to-end parity error is detected at the port.
31:1	Reserved	RO	0x0	Reserved field.

Notes

SWERRCTL - Switch Internal Error Reporting Control (0x4DC)

Bit Field	Field Name	Type	Default Value	Description
1:0	EEPE	RW	0x2	End-to-End Parity Error Reporting. This field controls the manner in which end-to-end parity errors detected at this port are reported. An end-to-end parity error is reported as specified in this field whenever the EEPE bit in the Switch Internal Error Status (SWERRSTS) register transitions from a zero to a one. 0x0 - (none) The parity error is not reported 0x1 - (correctable) The port generates an ERR_COR message to the root. 0x2 - (nonfatal) The port generates an ERR_NONFATAL message to the root. 0x3 - (fatal) The port generates an ERR_FATAL message to the root.
2	EEPEINT	RW	0x0	End-to-End Parity Error Interrupt. When this bit is set, it enables generation of INT/MSI TLP on detecting end-to-end parity error if the interrupt/MSI generation is enabled for the upstream port.
31:3	Reserved	RO	0x0	Reserved field.

SWERRCNT - Switch Internal Error Count (0x4E0)

Bit Field	Field Name	Type	Default Value	Description
7:0	EEPEC	RCW	0x0 Sticky	End-to-End Parity Error Count. This field is incremented each time an end-to-end parity error is detected at the port until it saturates at its maximum count value (i.e., it does not roll over from 0xFF to 0x00). This counter saturates at its maximum value. Reading this field causes it to be cleared.
31:8	Reserved	RO	0x0	Reserved field.

SWTOCTL - Switch Time-Out Control (0x4E4)

Bit Field	Field Name	Type	Default Value	Description
0	ETO	RW	0x1 Sticky	Enable Switch Time-outs. When this bit is set, switch time-outs for this port are enabled. In this mode, a TLP will be discarded if it has been in this port's input queue for more than the specified switch core time-out limit.
31:1	Reserved	RO	0x0	Reserved field.

Notes

SWTORCTL - Switch Time-Out Reporting Control (0x4E8)

Bit Field	Field Name	Type	Default Value	Description
1:0	PTLPTO	RW	0x2 Sticky	Posted TLP Time-Out Reporting. This field controls the manner in which posted TLP time-outs are reported. A time-out is reported as specified in this field whenever the corresponding bit in the Switch Time-Out Status (SWTOSTS) register transitions from a zero to a one. 0x0 - (none) The time-out is not reported 0x1 - (correctable) The port generates an ERR_COR message to the root. 0x2 - (nonfatal) The port generates an ERR_NONFATAL message to the root. 0x3 - (fatal) The port generates an ERR_FATAL message to the root.
3:2	NPTLPTO	RW	0x0 Sticky	Non-Posted TLP Time-Out Reporting. This field controls the manner in which non-posted TLP time-outs are reported. A time-out is reported as specified in this field whenever the corresponding bit in the Switch Time-Out Status (SWTOSTS) register transitions from a zero to a one. 0x0 - (none) The time-out is not reported 0x1 - (correctable) The port generates an ERR_COR message to the root. 0x2 - (nonfatal) The port generates an ERR_NONFATAL message to the root. 0x3 - (fatal) The port generates an ERR_FATAL message to the root.
5:4	CPTLPTO	RW	0x0 Sticky	Completion TLP Time-Out Reporting. This field controls the manner in which completion TLP time-outs are reported. A time-out is reported as specified in this field whenever the corresponding bit in the Switch Time-Out Status (SWTOSTS) register transitions from a zero to a one. 0x0 - (none) The time-out is not reported 0x1 - (correctable) The port generates an ERR_COR message to the root. 0x2 - (nonfatal) The port generates an ERR_NONFATAL message to the root. 0x3 - (fatal) The port generates an ERR_FATAL message to the root.
31:6	Reserved	RO	0x0	Reserved field.

SWTOCNT - Switch Time-Out Count (0x4EC)

Bit Field	Field Name	Type	Default Value	Description
7:0	PTLPTOC	RCW	0x0 Sticky	Posted TLP Time-Out Count. This field is incremented each time a TLP is discarded from the port's IPQ posted queue because of a time-out. This counter saturates at its maximum value. Reading this field causes it to be cleared.

Notes

Bit Field	Field Name	Type	Default Value	Description
15:8	NPTLPTOC	RCW	0x0 Sticky	Non-Posted TLP Time-Out Count. This field is incremented each time a TLP is discarded from the port's IPQ non-posted queue because of a time-out. This counter saturates at its maximum value. Reading this field causes it to be cleared.
24:16	CTLPTOC	RCW	0x0 Sticky	Completion TLP Time-Out Count. This field is incremented each time a TLP is discarded from the port's IPQ completion queue because of a time-out. This counter saturates at its maximum value. Reading this field causes it to be cleared.
31:25	Reserved	RO	0x0	Reserved field.

Wakeup Protocol Registers

[WAKEUPCNTL - Wakeup Protocol Control Register \(0x5CC\)](#)

Bit Field	Field Name	Type	Default Value	Description
0	WAKEEN	RWS	0x1 FRSticky	Wake Signal Enable. This field is used to enable or disable the WAKEN signal. 0x0 - (disable) Wake Signal is disabled 0x1 - (enable) Wake Signal is enabled
1	BCONEN	RWS	0x1 FRSticky	Beacon Enable. This field is used to enable or disable the in-band Beacon signaling. 0x0 - (disable) Beacon signalling is disabled 0x1 - (enable) Beacon signalling is enabled
31:2	Reserved	RO	0x0	Reserved field.

Notes



JTAG Boundary Scan

Notes

Introduction

The JTAG Boundary Scan interface provides a way to test the interconnections between integrated circuit pins after they have been assembled onto a circuit board. There are two pin types present in the PES3T3: AC-coupled and DC-coupled (also called AC and DC pins). The Boundary Scan interface in the PES3T3 is IEEE 1149.1 compliant to allow testing of the DC pins. The DC pins are those “normal” pins that do not require AC-coupling.

The presence of AC-coupling capacitors on some of the PES3T3 pins prevents DC values from being driven between a driver and receiver. An AC Boundary Scan methodology, as described in IEEE 1149.6, is available to provide a time-varying signal to pass through the AC-coupling when in AC test mode; however, IEEE 1149.6 is not supported in the PES3T3.

Test Access Point

The system logic utilizes a 16-state, TAP controller, a six-bit instruction register, and five dedicated pins to perform a variety of functions. The primary use of the JTAG TAP Controller state machine is to allow the five external JTAG control pins to control and access the PES3T3’s many external signal pins. The JTAG TAP Controller can also be used for identifying the device part number. The JTAG logic of the PES3T3 is depicted in Figure 10.1.

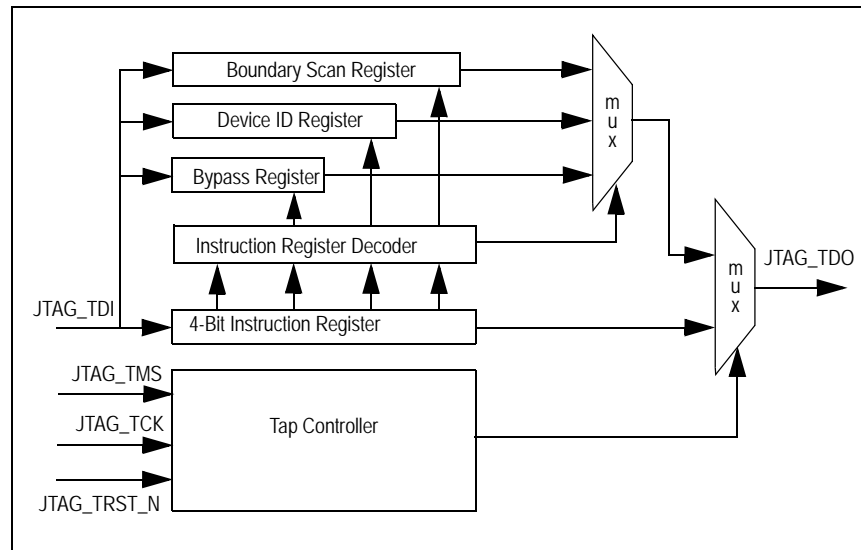

Figure 10.1 Diagram of the JTAG Logic

Refer to the IEEE 1149.1 and 1149.6 documents for a complete operational description of the Boundary Scan and TAP controller.

Signal Definitions

JTAG operations such as reset, state-transition control, and clock sampling are handled through the signals listed in Table 10.1. A functional overview of the TAP Controller and Boundary Scan registers is provided in the sections following the table.

Notes

Pin Name	Type	Description
JTAG_TRST_N	Input	JTAG RESET (active low) Asynchronous reset for JTAG TAP controller (internal pull-up)
JTAG_TCK	Input	JTAG Clock Test logic clock. JTAG_TMS and JTAG_TDI are sampled on the rising edge. JTAG_TDO is output on the falling edge.
JTAG_TMS	Input	JTAG Mode Select. Requires an external pull-up. Controls the state transitions for the TAP controller state machine (internal pull-up)
JTAG_TDI	Input	JTAG Input Serial data input for BSC chain, Instruction Register, IDCODE register, and BYPASS register (internal pull-up)
JTAG_TDO	Output	JTAG Output Serial data out. Tri-stated except when shifting while in Shift-DR and SHIFT-IR TAP controller states.

Table 10.1 JTAG Pin Descriptions

The TAP controller transitions from state to state, according to the value present on JTAG_TMS, as sampled on the rising edge of JTAG_TCK. The Test-Logic Reset state can be reached either by asserting JTAG_TRST_N or by applying a 1 to JTAG_TMS for five consecutive cycles of JTAG_TCK. A state diagram for the TAP controller appears in Figure 10.2. The value next to state represent the value that must be applied to JTAG_TMS on the next rising edge of JTAG_TCK, to transition in the direction of the associated arrow.

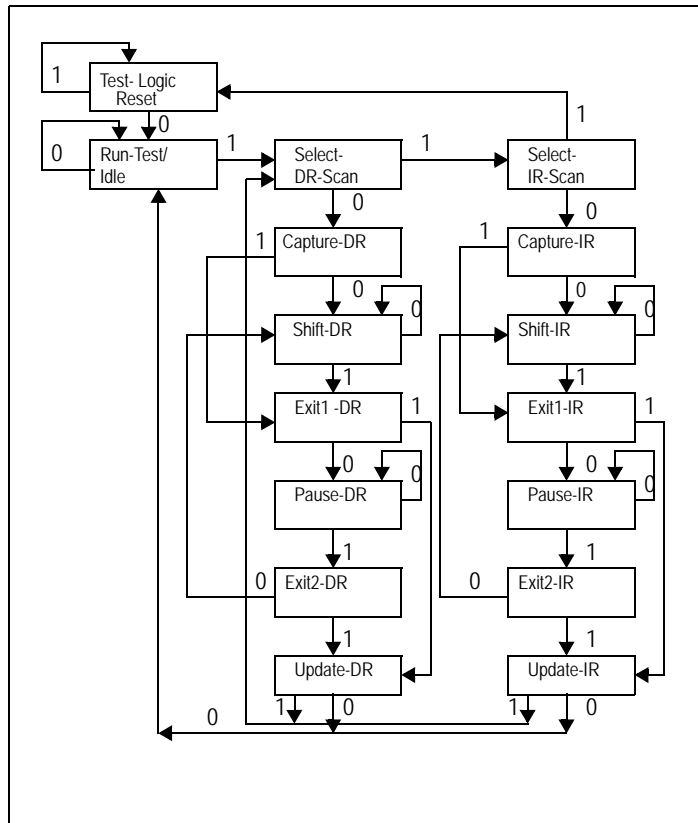

Figure 10.2 State Diagram of PES3T3's TAP Controller

Notes

Boundary Scan Chain

Function	Pin Name	Type ¹	Boundary Cell ²
PCI Express Interface	PE0RN[0]	I	0
	PE0RP[0]	I	0
	PE0TN[0]	O	C
	PE0TP[0]		
	PE2RN[0]	I	0
	PE2RP[0]	I	0
	PE2TN[0]	O	C
	PE2TP[0]		
	PE3RN[0]	I	0
	PE3RP[0]	I	0
	PE3TN[0]	O	C
	PE3TP[0]		
	PEREFCLKN	I	—
	PEREFCLKP	I	—
	SMBus	MSMBCLK	I/O
MSMBDAT		I/O	
General Purpose I/O	GPIO[9,7,2:0]	I/O	O/C
System Pins	APWRDISN	I	0
	CCLKDS	I	0
	CCLKUS	I	0
	PERSTN	I	0
	RSTHALT	I	0
	SWMODE[2:0]	I	—
	WAKEN	I/O	O/C
EJTAG / JTAG	JTAG_TCK	I	—
	JTAG_TDI	I	—
	JTAG_TDO	O	—
	JTAG_TMS	I	—
	JTAG_TRST_N	I	—

Table 10.2 Boundary Scan Chain

¹ I = Input, O = Output

² O = Observe, C = Control

Test Data Register (DR)

The Test Data register contains the following:

- ◆ Bypass register
- ◆ Boundary Scan registers

Notes

◆ Device ID register

These registers are connected in parallel between a common serial input and a common serial data output and are described in the following sections. For more detailed descriptions, refer to IEEE Standard Test Access Port (IEEE Std. 1149.1).

Boundary Scan Registers

This boundary scan chain is connected between JTAG_TDI and JTAG_TDO when EXTEST or SAMPLE/PRELOAD instructions are selected. Once EXTEST is selected and the TAP controller passes through the UPDATE-IR state, whatever value that is currently held in the boundary scan register's output latches is immediately transferred to the corresponding outputs or output enables.

Therefore, the SAMPLE/PRELOAD instruction must first be used to load suitable values into the boundary scan cells, so that inappropriate values are not driven out onto the system pins. All of the boundary scan cells feature a negative edge latch, which guarantees that clock skew cannot cause incorrect data to be latched into a cell. The input cells are sample-only cells. The simplified logic configuration is shown in Figure 10.3.

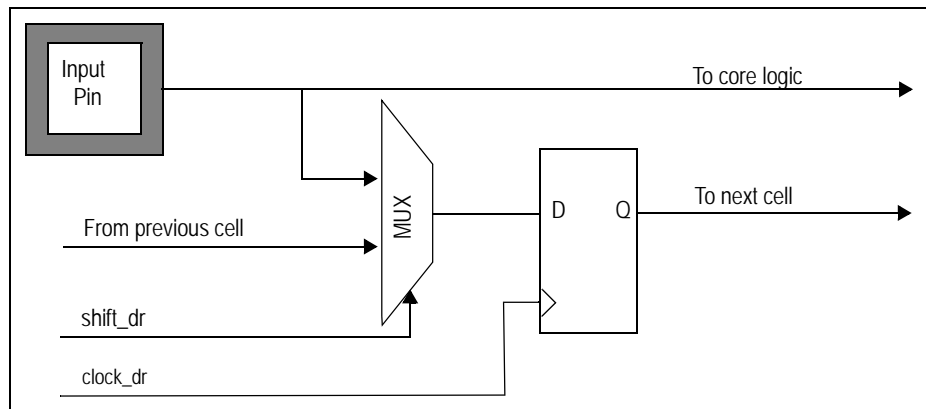

Figure 10.3 Diagram of Observe-only Input Cell

The simplified logic configuration of the output cells is shown in Figure 10.4.

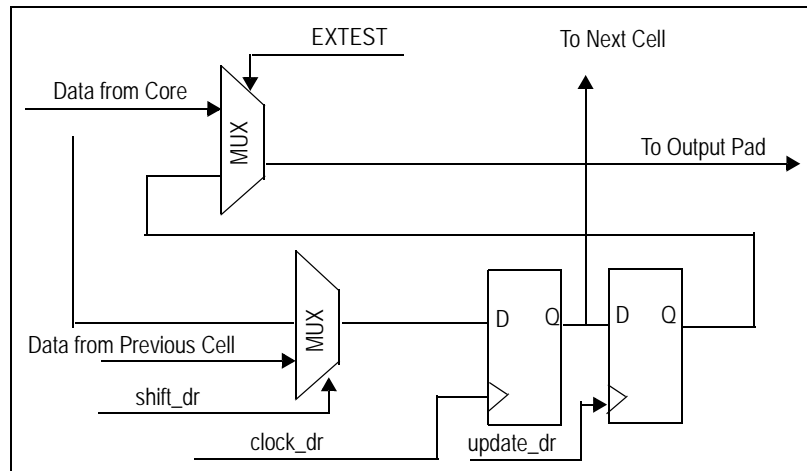

Figure 10.4 Diagram of Output Cell

Notes

The output enable cells are also output cells. The simplified logic is shown in Figure 10.5.

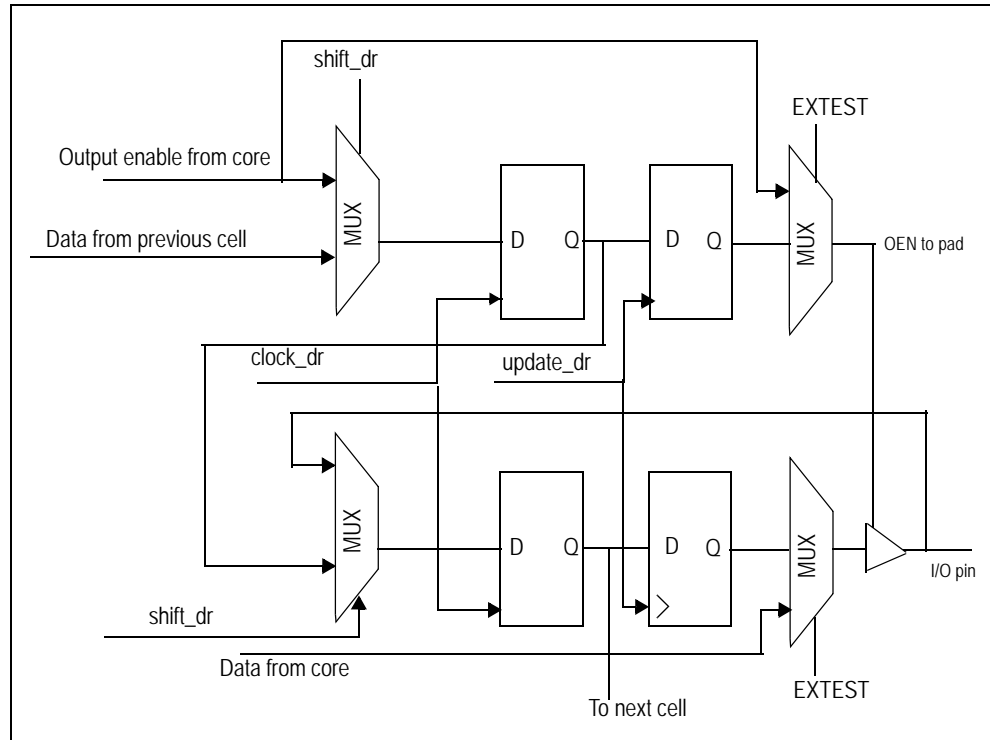

Figure 10.5 Diagram of Bidirectional Cell

The bidirectional cells are composed of only two boundary scan cells. They contain one output enable cell and one capture cell, which contains only one register. The input to this single register is selected via a mux that is selected by the output enable cell when EXTEST is disabled. When the Output Enable Cell is driving a high out to the pad (which enables the pad for output) and EXTEST is disabled, the Capture Cell will be configured to capture output data from the core to the pad.

However, in the case where the Output Enable Cell is low (signifying a tri-state condition at the pad) and EXTEST is enabled, the Capture Cell will capture input data from the pad to the core. The configuration is shown graphically in Figure 10.5.

Instruction Register (IR)

The Instruction register allows an instruction to be shifted serially into the device at the rising edge of JTAG_TCK. The instruction is then used to select the test to be performed or the test register to be accessed, or both. The instruction shifted into the register is latched at the completion of the shifting process, when the TAP controller is at the Update-IR state.

The Instruction register contains six shift-register-based cells that can hold instruction data. This register is decoded to perform the following functions:

- To select test data registers that may operate while the instruction is current. The other test data registers should not interfere with chip operation and selected data registers.
- To define the serial test data register path used to shift data between JTAG_TDI and JTAG_TDO during data register scanning.

The Instruction register is comprised of 6 bits to decode instructions, as shown in Table 10.3.

Notes

Instruction	Definition	Opcode
EXTEST	Mandatory instruction allowing the testing of board level interconnections. Data is typically loaded onto the latched parallel outputs of the boundary scan shift register using the SAMPLE/PRELOAD instruction prior to use of the EXTEST instruction. EXTEST will then hold these values on the outputs while being executed. Also see the CLAMP instruction for similar capability.	000000
SAMPLE/ PRELOAD	Mandatory instruction that allows data values to be loaded onto the latched parallel output of the boundary scan shift register prior to selection of the other boundary scan test instruction. The Sample instruction allows a snapshot of data flowing from the system pins to the on-chip logic or vice versa.	000001
IDCODE	Provided to select Device Identification to read out manufacturer's identity, part, and version number.	000010
HIGHZ	Tri-states all output and bidirectional boundary scan cells.	000011
RESERVED		000100 — 101100
VALIDATE	Automatically loaded into the instruction register whenever the TAP controller passes through the CAPTURE-IR state. The lower two bits '01' are mandated by the IEEE Std. 1149.1 specification.	101101
RESERVED		101110 — 111101
CLAMP	Provides JTAG users with the option to bypass the part's JTAG controller while keeping the part outputs controlled similar to EXTEST.	111110
BYPASS	The BYPASS instruction is used to truncate the boundary scan register as a single bit in length.	111111

Table 10.3 Instructions Supported by PES3T3's JTAG Boundary Scan

EXTEST

The external test (EXTEST) instruction is used to control the boundary scan register, once it has been initialized using the SAMPLE/PRELOAD instruction. Using EXTEST, the user can then sample inputs from or load values onto the external pins of the PES3T3. Once this instruction is selected, the user then uses the SHIFT-DR TAP controller state to shift values into the boundary scan chain. When the TAP controller passes through the UPDATE-DR state, these values will be latched onto the output pins or into the output enables.

SAMPLE/PRELOAD

The sample/preload instruction has a dual use. The primary use of this instruction is for preloading the boundary scan register prior to enabling the EXTEST instruction. Failure to preload will result in unknown random data being driven onto the output pins when EXTEST is selected. The secondary function of SAMPLE/PRELOAD is for sampling the system state at a particular moment. Using the SAMPLE function, the user can halt the device at a certain state and shift out the status of all of the pins and output enables at that time.

BYPASS

The BYPASS instruction is used to truncate the boundary scan register to a single bit in length. During system level use of the JTAG, the boundary scan chains of all the devices on the board are connected in series. In order to facilitate rapid testing of a given device, all other devices are put into BYPASS mode.

Notes

Therefore, instead of having to shift many times to get a value through the PES3T3, the user only needs to shift one time to get the value from JTAG_TDI to JTAG_TDO. When the TAP controller passes through the CAPTURE-DR state, the value in the BYPASS register is updated to be 0.

CLAMP

This instruction, listed as optional in the IEEE 1149.1 JTAG Specifications, allows the boundary scan chain outputs to be clamped to fixed values. When the clamp instruction is issued, the bypass register is selected between TDI and TDO and the scan chain passes through this register to devices further downstream.

IDCODE

The IDCODE instruction is automatically loaded when the TAP controller state machine is reset either by the use of the JTAG_TRST_N signal or by the application of a '1' on JTAG_TMS for five or more cycles of JTAG_TCK as per the IEEE Std. 1149.1 specification. The least significant bit of this value must always be 1. Therefore, if a device has a Device ID register, it will shift out a 1 on the first shift if it is brought directly to the SHIFT-DR TAP controller state after the TAP controller is reset. The board-level tester can then examine this bit and determine if the device contains a Device ID register (the first bit is a 1), or if the device only contains a BYPASS register (the first bit is 0).

However, even if the device contains a Device ID register, it must also contain a BYPASS register. The only difference is that the BYPASS register will not be the default register selected during the TAP controller reset. When the IDCODE instruction is active and the TAP controller is in the Shift-DR state, the thirty-two bit value that will be shifted out of the Device ID register is shown in Figure 10.6.

Bit(s)	Mnemonic	Description	R/W	Reset
0	Reserved	Reserved	R	0x1
11:1	Manuf_ID	Manufacturer Identity (11 bits) This field identifies the manufacturer as IDT.	R	0x33
27:12	Part_number	Part Number (16 bits) This field identifies the silicon as PES3T3.	R	0x8039
31:28	Version	Version (4 bits) This field identifies the silicon revision of the PES3T3.	R	silicon-dependent

Table 10.4 System Controller Device Identification Register

Version	Part Number	Mnfg. ID	LSB
xxxx	1000 0000 0011 1001	0000 0011 0011	1

Figure 10.6 Device ID Register Format

VALIDATE

The VALIDATE instruction is automatically loaded into the instruction register whenever the TAP controller passes through the CAPTURE-IR state. The lower two bits '01' are mandated by the IEEE Std. 1149.1 specification.

RESERVED

Reserved instructions implement various test modes used in the device manufacturing process. The user should not enable these instructions.

Notes

Usage Considerations

As previously stated, there are internal pull-ups on JTAG_TRST_N, JTAG_TMS, and JTAG_TDI. However, JTAG_TCK also needs to be driven to a known value. It is best to either drive a zero on the JTAG_TCK pin when it is not being used or to use an external pull-down resistor. In order to guarantee that the JTAG does not interfere with normal system operation, the TAP controller should be forced into the Test-Logic-Reset controller state by continuously holding JTAG_TRST_N low and/or JTAG_TMS high when the chip is in normal operation. If JTAG will not be used, externally pull-down JTAG_TRST_N low to disable it.

IMPORTANT NOTICE AND DISCLAIMER

RENESAS ELECTRONICS CORPORATION AND ITS SUBSIDIARIES (“RENESAS”) PROVIDES TECHNICAL SPECIFICATIONS AND RELIABILITY DATA (INCLUDING DATASHEETS), DESIGN RESOURCES (INCLUDING REFERENCE DESIGNS), APPLICATION OR OTHER DESIGN ADVICE, WEB TOOLS, SAFETY INFORMATION, AND OTHER RESOURCES “AS IS” AND WITH ALL FAULTS, AND DISCLAIMS ALL WARRANTIES, EXPRESS OR IMPLIED, INCLUDING, WITHOUT LIMITATION, ANY IMPLIED WARRANTIES OF MERCHANTABILITY, FITNESS FOR A PARTICULAR PURPOSE, OR NON-INFRINGEMENT OF THIRD-PARTY INTELLECTUAL PROPERTY RIGHTS.

These resources are intended for developers who are designing with Renesas products. You are solely responsible for (1) selecting the appropriate products for your application, (2) designing, validating, and testing your application, and (3) ensuring your application meets applicable standards, and any other safety, security, or other requirements. These resources are subject to change without notice. Renesas grants you permission to use these resources only to develop an application that uses Renesas products. Other reproduction or use of these resources is strictly prohibited. No license is granted to any other Renesas intellectual property or to any third-party intellectual property. Renesas disclaims responsibility for, and you will fully indemnify Renesas and its representatives against, any claims, damages, costs, losses, or liabilities arising from your use of these resources. Renesas' products are provided only subject to Renesas' Terms and Conditions of Sale or other applicable terms agreed to in writing. No use of any Renesas resources expands or otherwise alters any applicable warranties or warranty disclaimers for these products.

(Disclaimer Rev.1.01)

Corporate Headquarters

TOYOSU FORESIA, 3-2-24 Toyosu,
Koto-ku, Tokyo 135-0061, Japan
www.renesas.com

Trademarks

Renesas and the Renesas logo are trademarks of Renesas Electronics Corporation. All trademarks and registered trademarks are the property of their respective owners.

Contact Information

For further information on a product, technology, the most up-to-date version of a document, or your nearest sales office, please visit www.renesas.com/contact-us/.