



IDT™ 89EBPES24T3G2 Evaluation Board Manual

(Eval Board: 18-657-000)

January 2008

6024 Silver Creek Valley Road, San Jose, California 95138
Telephone: (800) 345-7015 • (408) 284-8200 • FAX: (408) 284-2775
Printed in U.S.A.
©2008 Integrated Device Technology, Inc.

DISCLAIMER

Integrated Device Technology, Inc. reserves the right to make changes to its products or specifications at any time, without notice, in order to improve design or performance and to supply the best possible product. IDT does not assume any responsibility for use of any circuitry described other than the circuitry embodied in an IDT product. The Company makes no representations that circuitry described herein is free from patent infringement or other rights of third parties which may result from its use. No license is granted by implication or otherwise under any patent, patent rights or other rights, of Integrated Device Technology, Inc.

Boards that fail to function should be returned to IDT for replacement. Credit will not be given for the failed boards nor will a Failure Analysis be performed.

LIFE SUPPORT POLICY

Integrated Device Technology's products are not authorized for use as critical components in life support devices or systems unless a specific written agreement pertaining to such intended use is executed between the manufacturer and an officer of IDT.

1. Life support devices or systems are devices or systems which (a) are intended for surgical implant into the body or (b) support or sustain life and whose failure to perform, when properly used in accordance with instructions for use provided in the labeling, can be reasonably expected to result in a significant injury to the user.
2. A critical component is any components of a life support device or system whose failure to perform can be reasonably expected to cause the failure of the life support device or system, or to affect its safety or effectiveness.

IDT, the IDT logo, and Integrated Device Technology are trademarks or registered trademarks of Integrated Device Technology, Inc.



Table of Contents

Notes

Description of the EB24T3G2 Eval Board

| | |
|------------------------|-----|
| Introduction | 1-1 |
| Board Features | 1-2 |
| Hardware | 1-2 |
| Software..... | 1-2 |
| Other..... | 1-2 |
| Revision History | 1-2 |

Installation of the EB24T3G2 Eval Board

| | |
|--|------|
| EB24T3G2 Installation | 2-1 |
| Hardware Description | 2-1 |
| Reference Clocks..... | 2-1 |
| Power Sources..... | 2-2 |
| External Power Source | 2-2 |
| PCI Express Analog High Power Voltage Converter | 2-2 |
| PCI Express Analog Power Voltage Converter | 2-2 |
| PCI Express Transmitter Analog Power Voltage Converter | 2-2 |
| Core Logic Voltage Converter | 2-2 |
| 3.3V I/O Voltage Regulator | 2-2 |
| Power-up Sequence | 2-3 |
| Reset..... | 2-3 |
| Fundamental Reset | 2-3 |
| Downstream Reset | 2-3 |
| Boot Configuration Vector..... | 2-3 |
| SMBus Interfaces..... | 2-4 |
| SMBus Slave Interface | 2-4 |
| SMBus Master Interface | 2-5 |
| JTAG Header | 2-6 |
| Attention Buttons..... | 2-6 |
| Miscellaneous Jumpers, Headers..... | 2-7 |
| LEDs | 2-7 |
| PCI Express Connectors..... | 2-8 |
| EB24T3G2 Board Figure | 2-10 |

Software for the EB24T3G2 Eval Board

| | |
|---------------------------------|-----|
| Introduction | 3-1 |
| Device Management Software..... | 3-1 |

Schematics

| | |
|------------------|-----|
| Schematics | 4-1 |
|------------------|-----|

Notes



List of Tables

Notes

| | | |
|------------|--|-----|
| Table 2.1 | Clock Source Selection | 2-1 |
| Table 2.2 | SMA Connectors - Onboard Reference Clock | 2-2 |
| Table 2.3 | External Power Connector - J1 | 2-2 |
| Table 2.4 | Downstream Reset Selection | 2-3 |
| Table 2.5 | Boot Configuration Vector Signals | 2-4 |
| Table 2.6 | Boot Configuration Vector Switches S7 & S8 (ON=0, OFF=1) | 2-4 |
| Table 2.7 | Slave SMBus Interface Connector | 2-5 |
| Table 2.8 | EEPROM SMBus Address Setting | 2-5 |
| Table 2.9 | JTAG Connector Pin Out | 2-6 |
| Table 2.10 | Attention Buttons | 2-6 |
| Table 2.11 | Miscellaneous Jumpers, Headers | 2-7 |
| Table 2.12 | LED Indicators | 2-7 |
| Table 2.13 | PCI Express x8 Connector Pinout | 2-8 |

Notes



List of Figures

Notes

| | | |
|------------|---|-----|
| Figure 1.1 | Function Block Diagram of the EB24T3G2 Eval Board | 1-1 |
|------------|---|-----|

Notes



Description of the EB24T3G2 Eval Board

Notes

Introduction

The 89HPES24T3G2 switch (also referred to as PES24T3G2 in this manual) is a member of IDT's PCI Express® standard based line of products. It is a PCIe® Base Specification 2.0 compliant (Gen2) 3-port switch, with 8 serial lanes per port. One x8 upstream port is provided for connecting to the root complex (RC), and two x8 downstream ports are available for connecting to PCIe endpoints or to another switch. More information on this device can be found in the 89HPES24T3G2 User Manual.

The 89EBPES24T3G2 Evaluation Board (also referred to as EB24T3G2 in this manual) provides an evaluation platform for the PES24T3G2 switch. It is also a cost effective way to add PCIe ports (slots) to an existing system with limited number of PCIe ports/slots. The EB24T3G2 board is designed to function as an add-on card to be plugged into a x8 PCIe slot available on a motherboard hosting an appropriate root complex and microprocessor(s). The EB24T3G2 is a vehicle to test and evaluate the functionality of the PES24T3G2 switch. Customers can use this board to get a headstart on software development prior to the arrival of their own hardware. The EB24T3G2 is also used by IDT to reproduce system-level hardware or software issues reported by customers. Figure 1.1 illustrates the functional block diagram representing the main parts of the EB24T3G2 board.

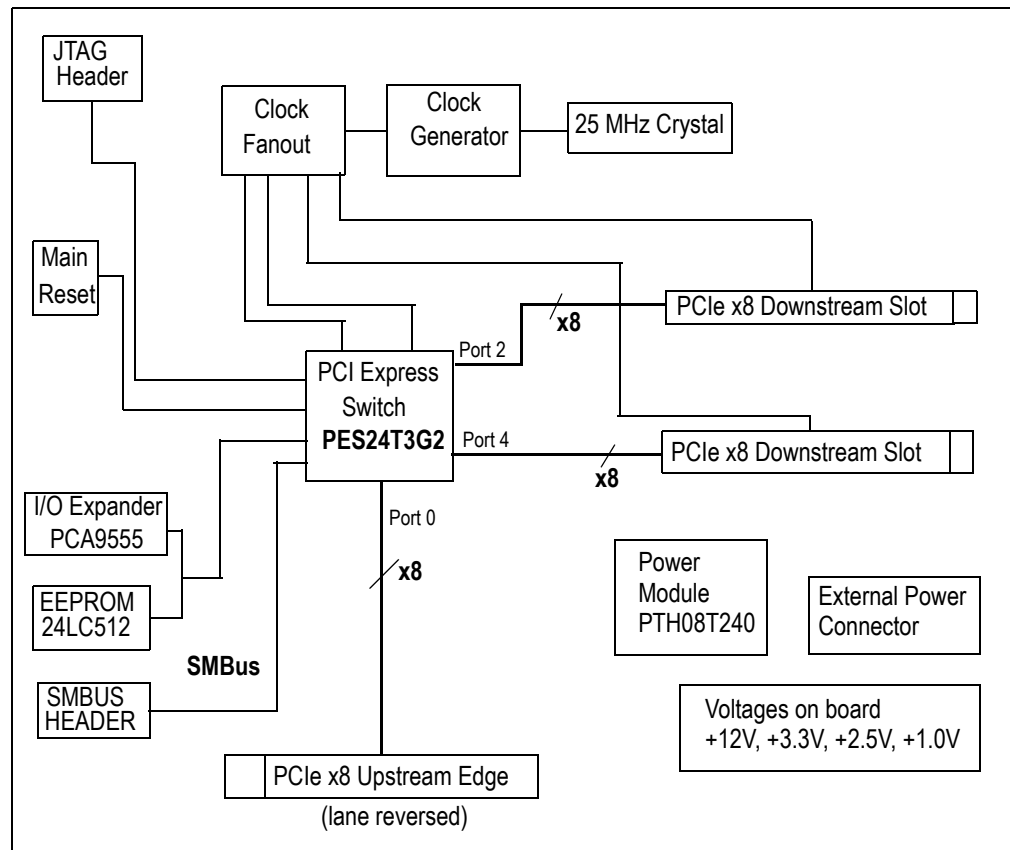

Figure 1.1 Function Block Diagram of the EB24T3G2 Eval Board

Notes

Board Features

Hardware

- ◆ **PES24T3G2 PCIe 3 port switch**
 - Three x8 ports, 24 PCIe lanes
 - PCIe Base Specification Revision 2.0 compliant (Gen2 SerDes speeds of 5 GT/S)
 - Up to 2048 byte maximum Payload Size
 - Automatic lane reversal and polarity inversion supported on all lanes
 - Automatic per port link width negotiation to x8, x4, x2, x1
 - Load configuration from an optional serial EEPROM via SMBUS
- ◆ **Upstream, Downstream Port**
 - One edge connector on the upstream port, to be plugged into a slot with at least x8 capable on a host motherboard
 - Two slot connectors on the downstream ports, for PCIe endpoint add-on cards to be plugged in. These slot connectors are x8 mechanically but open-ended for card widths greater than x8 (e.g. x16)
- ◆ **Numerous user selectable configurations set using onboard jumpers and DIP-switches**
 - Source of clock - host clock or onboard clock generator
 - Two clock rates (100/125 MHz) from an onboard clock generator
 - Boot mode selection
- ◆ **SMBUS Slave Interface (4 pin header)**
- ◆ **SMBUS Master Interface connected to the Serial EEPROMs through I/O expander**
- ◆ **“Attention” button for each downstream port to initiate a hot swap event on each port**
- ◆ **Four pin connector for optional external power supply**
- ◆ **Push button for Warm Reset**
- ◆ **Several LEDs to display status, reset, power, “Attention”, etc.**
- ◆ **One 10-pin JTAG connector (pitch 2.54 mm x 2.54 mm)**

Software

There is no software or firmware executed on the board. However, useful software is provided along with the Evaluation Board to facilitate configuration and evaluation of the PES24T3G2 within host systems running popular operating systems.

- ◆ **Installation programs**
 - *Operating Systems Supported: Windows2000, WindowsXP, Vista, Linux*
- ◆ **GUI based application for Windows and Linux**
 - *Allows users to view and modify registers in the PES24T3G2*
 - *Binary file generator for programming the serial EEPROMs attached to the SMBUS.*

Other

- ◆ A metal bracket is provided to firmly hold in place two endpoints plugged into the EB24T3G2 board.
- ◆ An external power supply may be required under some conditions.
- ◆ SMBUS cable may be required for certain evaluation exercises.
- ◆ SMA connectors are provided on the EB24T3G2 board for clock outputs.

Revision History

January 21, 2008: Initial publication of eval board manual.



Installation of the EB24T3G2 Eval Board

Notes

EB24T3G2 Installation

This chapter discusses the steps required to configure and install the EB24T3G2 evaluation board. All available DIP switches and jumper configurations are explained in detail.

The primary installation steps are:

1. Configure jumper/switch options suitable for the evaluation or application requirements.
2. Connect PCI Express endpoint cards to the downstream port PCIe slots on the evaluation board.
3. Make sure that the host system (motherboard with root complex chipset) is powered off.
4. Insert the evaluation board into the host system.
5. Apply power to the host system.

The EB24T3G2 board is typically shipped with all jumpers and switches configured to their default settings. In most cases, the board does not require further modification or setup.

Hardware Description

The PES24T3G2 is a 24-lane, 3-port PCI Express® switch. It is a peripheral chip that performs PCI Express based switching with a feature set optimized for high performance applications such as servers and storage. It provides fan-out and switching functions between a PCI Express upstream port and downstream ports or peer-to-peer switching between downstream ports.

The EB24T3G2 has two PCI Express downstream ports, accessible through two x8 connectors. Both ports are capable of negotiating a x1, x2, x4, and x8 link width. All endpoint cards connected to the PES24T3G2 must support one of these link widths.

Basic requirements for the board to run are:

- Host system with a PCI Express root complex supporting at least x8 configuration through a PCI Express x8 or larger slot.
- x1, x2, x4 or x8 PCI Express Endpoint Cards.

Reference Clocks

The PES24T3G2 requires a differential reference clock. The EB24T3G2 derives this clock from a common source which is user-selectable. The common source can be either the host system's reference clock or it can be the onboard clock generator. Selection is made by stuffing resistors as in Table 2.1.

| Clock Configuration Stuffing Option | |
|-------------------------------------|---|
| W6 and W7 | Clock Source |
| Pins 2 and 3 | Onboard Reference Clock – Use onboard clock generator |
| Pins 1 and 2 | Upstream Reference Clock – Host system provides clock (Default) |

Table 2.1 Clock Source Selection

The source for the onboard clock is the ICS841484 clock generator device (U4) connected to a 25MHz oscillator (Y1). When using the onboard clock generator, the output frequency is fixed at 100MHz, therefore FSEL0 (S7, bit 8) is On as the default setting.

Notes

The output of the onboard clock generator is accessible through two SMA connectors located on the Evaluation Board. See Table 2.2. This can be used to connect a scope for probing or capturing purposes and cannot be used to drive the clock from an external source.

| Onboard Reference Clock Output (Differential) – J7, J6 | |
|---|--------------------------|
| J9 | Positive Reference Clock |
| J10 | Negative Reference Clock |

Table 2.2 SMA Connectors - Onboard Reference Clock

Power Sources

The EB24T3G2 and both downstream ports are powered from the upstream port slot power. If add-in cards require more power than the upstream slot can support, an external source is required to supply this extra power via an auxiliary 4-pin power connector on the board. Header W1, W2, and W3 (see Table 2.11) are used to select proper power source for the switch and all downstream ports.

External Power Source

If necessary, external power is supplied to the EB24T3G2 board through a 4-pin auxiliary power connector attached to J4. The external power supply provides +12V to the EB24T3G2 as described in Table 2.3. The +5V is unused.

| Pin | Signal |
|------------|---------------|
| 1 | +12V |
| 2 | GND |
| 3 | GND |
| 4 | +5V |

Table 2.3 External Power Connector - J1

PCI Express Analog High Power Voltage Converter

A DC-DC converter (U18) provides a 2.5V PCI Express analog high power voltage (shown as VDDHA) to the PES24T3G2.

PCI Express Analog Power Voltage Converter

A separate DC-DC converter (U16) provides a 1.0V PCI Express analog power voltage (VDDA) to the PES24T3G2.

PCI Express Transmitter Analog Power Voltage Converter

A separate DC-DC converter (U17) provides a 1.0V PCI Express transmitter analog power voltage (shown as VDDPETA) to the PES24T3G2.

Core Logic Voltage Converter

A separate DC-DC converter (U15) provides the 1.0V core voltage (VDDCORE) to the PES24T3G2.

3.3V I/O Voltage Regulator

A 12V to 3.3V voltage regulator (VR1) provides the 3.3V I/O voltage (VDDIO) to the PES24T3G2.

Notes

Power-up Sequence

During power supply ramp-up, VDDCORE must remain at least 1.0V below VDDIO at all times. There are no other power-up sequence requirements for the various operating supply voltages.

Reset

The PES24T3G2 supports two types of reset mechanisms as described in the PCI Express specification:

- Fundamental Reset: This is a system-generated reset that propagates along the PCI Express tree through a single side-band signal PERST# which is connected to the Root Complex, the PES24T3G2, and the endpoints.
- Hot Reset: This is an In-band Reset, communicated downstream via a link from one device to another. Hot Reset may be initiated by software. This is further discussed in the 89HPES24T3G2 User Manual. The EB24T3G2 evaluation board provides seamless support for Hot Reset.

Fundamental Reset

There are two types of Fundamental Resets which may occur on the EB24T3G2 evaluation board:

- Cold Reset: During initial power-on, the onboard voltage monitor (TLC7733D) will assert the PCI Express Reset (PERSTN) input pin of the PES24T3G2.
- Warm Reset: This is triggered by hardware while the device is powered on. Warm Reset can be initiated by two methods:
 - Pressing a push-button switch (S1) located on EB24T3G2 board
 - The host system board IO Controller Hub asserting PERST# signal, which propagates through the PCIe upstream edge connector of the EB24T3G2. Note that one can bypass the onboard voltage monitor (TLC7733D) by moving the shunt from pin 1-2 to pin 2-3 (default) on W4.

Both events cause the onboard voltage monitor (TLC7733D) to assert the PCI Express Reset (PERSTN) input of the PES24T3G2 while power is on.

Downstream Reset

The PES24T3G2 provides a choice of either a software-controlled reset for each downstream port through GPIO pins or a fundamental reset through PERST#. Selection is made by jumpers described in Table 2.4.

| Port # | Jumper | Selection |
|--------|--------|---|
| 2 | W19 | [1-2] Software controlled reset through GPIO0 [2-3] Fundamental reset PERST# (default) |
| 4 | W18 | [1-2] Software controlled reset through GPIO1 [2-3] Fundamental reset PERST# (default) |

Table 2.4 Downstream Reset Selection

Boot Configuration Vector

A boot configuration vector consisting of the signals listed in Table 2.5 is sampled by the PES24T3G2 during a fundamental reset (while PERSTN is active). The boot configuration vector defines the essential parameters for switch operation and is set using DIP switches S7 and S8 as defined in Table 2.6.

Notes

| Signal | Description |
|-------------|---|
| CCLKDS | Common Clock Downstream. The assertion of this pin indicates that all downstream ports are using the same clock source as that provided to downstream devices. This pin is used as the initial value of the Slot Clock Configuration bit in all of the Link Status Registers for downstream ports. The value may be overridden by modifying the SCLK bit in the downstream port's PCIELSTS register. Default: 0x1 |
| CCLKUS | Common Clock Upstream. The assertion of this pin indicates that the upstream port is using the same clock source as the upstream device. This pin is used as the initial value of the Slot Clock Configuration bit in the Link Status Register for the upstream port. The value may be overridden by modifying the SCLK bit in the P0_PCIELSTS register. Default: 0x1 |
| SWMODE[2:0] | Switch Mode. These configuration pins determine the PES24T3G2 switch operating mode. Default: 0x0 0x0 - Normal switch mode 0x1 - Normal switch mode with Serial EEPROM-based initialization 0x2 through 0x7 - Reserved |

Table 2.5 Boot Configuration Vector Signals

| Signal | Description | Default |
|--------|-------------|---------|
| S8[1] | CCLKDS | OFF |
| S8[2] | CCLKUS | OFF |
| S7[1] | SWMODE[0] | ON |
| S7[2] | SWMODE[1] | ON |
| S7[3] | SWMODE[2] | ON |

Table 2.6 Boot Configuration Vector Switches S7 & S8 (ON=0, OFF=1)

SMBus Interfaces

The System Management Bus (SMBus) is a two-wire interface through which various system component chips can communicate. It is based on the principles of operation of I²C. Implementation of the SMBus signals in the PCI Express connector is optional and may not be present on the host system. The SMBus interface consists of an SMBus clock pin and an SMBus data pin.

Note: MSMBADDR and SSMBADDR address pins are not available in the PES24T3G2. The MSMBADDR address is hardwired to 0x50, and the SSMBADDR address is hardwired to 0x77.

The PES24T3G2 contains two SMBus interfaces: a slave SMBus interface and a master SMBus interface. The slave SMBus interface allows a SMBus Master device full access to all software-visible registers. The Master SMBus interface provides connection to the external serial EEPROM used for initialization and the I/O expanders used for hot-plug signals.

SMBus Slave Interface

On the PES24T3G2 board, the slave SMBus interface is accessible through the PCI Express edge connector as well as a 4-pin header as described in Table 2.7.

Note: The SMBus signals to the PCI Express edge connector is disabled by default. To enable them, place 0-ohm resistors at locations R160 and R161.

Notes

| Slave SMBus Interface Connector J8 | |
|---|---------------|
| Pin | Signal |
| 1 | N/C |
| 2 | SCL |
| 3 | GND |
| 4 | SDA |

Table 2.7 Slave SMBus Interface Connector

The slave SMBus interface responds to the following SMBus transactions initiated by an SMBus master. Initiation of any SMBus transaction other than those listed above produces undefined results. See the SMBus 2.0 specification for a detailed description of the following transactions:

- Byte and Word Write/Read
- Block Write/Read

SMBus Master Interface

Connected to the master SMBus interface are four 16-bit I/O Expanders (PCA9555) and a serial EEPROM (24LC512). Four I/O Expanders are used as the interface for the onboard hot-plug controllers (MIC2591B). The lower three bits of the bus address for the I/O Expander0/1/2/4 are fixed as 0x0, 0x1, 0x2 and 0x4, respectively.

The seven bits address for the selected EEPROM device is **0b1010_000** by default and the lower three bit is configurable using switch S8 as described in 2.8.

| S8[3] | S8[4] | S8[5] | Bus Address |
|--------------|--------------|--------------|--------------------|
| OFF | OFF | OFF | 0b111 |
| OFF | OFF | ON | 0b110 |
| OFF | ON | OFF | 0101 |
| OFF | ON | ON | 0b100 |
| ON | OFF | OFF | 0b011 |
| ON | OFF | ON | 0b010 |
| ON | ON | OFF | 0b001 |
| ON | ON | ON | 0b000 (Default) |

Table 2.8 EEPROM SMBus Address Setting

Notes

JTAG Header

The PES24T3G2 provides a JTAG connector J5 for access to the PES24T3G2 JTAG interface. The connector is a 2.54 x 2.54 mm pitch male 10-pin connector. Refer to Table 2.9 for the JTAG Connector J5 pin out.

| JTAG Connector J5 | | | | | |
|-------------------|------------------------|-----------|-----|--------|-----------|
| Pin | Signal | Direction | Pin | Signal | Direction |
| 1 | /TRST - Test reset | Input | 2 | GND | — |
| 3 | TDI - Test data | Input | 4 | GND | — |
| 5 | TDO - Test data | Output | 6 | GND | — |
| 7 | TMS - Test mode select | Input | 8 | GND | — |
| 9 | TCK - Test clock | Input | 10 | GND | — |

Table 2.9 JTAG Connector Pin Out

Attention Buttons

The PES24T3G2 features three attention buttons, shown in 2.10. Each button corresponds to a particular port and is used to initiate hot-swapping events.

| Button | Description |
|--------|-------------------------|
| S5 | Port 2 Attention Button |
| S3 | Port 4 Attention Button |

Table 2.10 Attention Buttons

Notes

Miscellaneous Jumpers, Headers

| Miscellaneous Jumpers, Headers | | | |
|--------------------------------|--------|-------------|---|
| Ref. Designator | Type | Default | Description |
| W1-W3 | Header | 1-2 Shunted | 1-2: 12.0V source from Upstream Port (Default) 2-3: 12.0V source from external power connector |
| W20 | Header | Shunted | Disable EEPROM Write protect feature (Default) |
| S6[1] | Switch | ON | ON: Port2, Force hot-plug controller on OFF: Port2, Power Enable bit controls hot-plug controller |
| S6[2] | Switch | ON | ON: Port4, Force hot-plug controller on OFF: Port4, Power Enable bit controls hot-plug controller |
| W15 | Header | 2-3 Shunted | 2-3: Port 2, +12V source from Upstream port (Default) 1-2: Port 2, +12V source from hot-plug controller |
| W9 | Header | 2-3 Shunted | 2-3: Port 4, +12V source from Upstream port (Default) 1-2: Port 4, +12V source from hot-plug controller |
| W16 | Header | 2-3 Shunted | 2-3: Port 2, +3.3V source from Upstream port (Default) 1-2: Port 2, +3.3V source from hot-plug controller |
| W10 | Header | 2-3 Shunted | 2-3: Port 4, +3.3V source from Upstream port (Default) 1-2: Port 4, +3.3V source from hot-plug controller |
| W14 | Header | 2-3 Shunted | 2-3: Port 2, +3.3AUX source from upstream port (Default) 1-2: Port 2, +3.3V source from hot-plug controller |
| W8 | Header | 2-3 Shunted | 2-3: Port 4, +3.3AUX source from upstream port (Default) 1-2: Port 4, +3.3V source from hot-plug controller |

Table 2.11 Miscellaneous Jumpers, Headers

LEDs

There are several LED indicators on the EB24T3G2 which convey status feedback. A description of each is provided in Table 2.12.

| Location | Color | Definition |
|----------|--------|---------------------------------|
| DS21 | Green | Port 2: Power-is-good Indicator |
| DS15 | Green | Port 4: Power-is-good Indicator |
| DS20 | Green | Port 2: Power Indicator |
| DS14 | Green | Port 4: Power Indicator |
| DS19 | Yellow | Port 2: Attention Indicator |
| DS13 | Yellow | Port 4: Attention Indicator |
| DS18 | Green | Port 2: Activity Indicator |
| DS12 | Green | Port 4: Activity Indicator |
| DS17 | Green | Port 2: Linkup Indicator |
| DS11 | Green | Port 4: Linkup Indicator |

Table 2.12 LED Indicators (Part 1 of 2)

Notes

| Location | Color | Definition |
|----------|-------|--|
| DS23 | Green | Port 0: Linkup Indicator |
| DS24 | Green | Port 0: Activity Indicator |
| DS7 | Red | Port 2: Power Fault Indicator |
| DS10 | Red | Port 4: Power Fault Indicator |
| DS25 | Green | GPIO8 |
| DS5 | Green | GPIO9 |
| DS26 | Green | GPIO10 |
| DS6 | Red | Port 2: Manual Retention Latch Indicator |
| DS9 | Red | Port 4: Manual Retention Latch Indicator |
| DS8 | Green | Port 2: Presence Detect Indicator |
| DS27 | Green | Port 4: Presence Detect Indicator |

Table 2.12 LED Indicators (Part 2 of 2)

PCI Express Connectors

| Pin | Side A | | Side B | |
|-----------------------|---------|------------------------------------|-----------|-----------------------------------|
| | 1 | +12V | 12V power | PRSNT1# |
| 2 | +12V | 12V power | +12V | 12V power |
| 3 | RSVD | Reserved | +12V | 12V power |
| 4 | GND | Ground | GND | Ground |
| 5 | SMCLK | SMBus clock | JTAG2 | TCK (Test Clock) JTAG i/f clk i/p |
| 6 | SMDAT | SMBus Data | JTAG | TDI (Test Data Input) |
| 7 | GND | Ground | JTAG | TDO (Test Data Output) |
| 8 | +3.3V | 3.3V power | JTAG | TMS (Test Mode Select) |
| 9 | JTAG1 | TRST# (Test/Reset) resets JTAG i/f | +3.3V | 3.3V power |
| 10 | 3.3Vaux | 3.3V auxiliary power | +3.3V | 3.3V power |
| 11 | WAKE# | Signal for Link reactivation | PERST# | Fundamental Reset |
| Mechanical Key | | | | |
| 12 | RSVD | Reserved | GND | Ground |
| 13 | GND | Ground | REFCLK+ | REFCLK Reference clock |
| 14 | PETp0 | Transmitter differential | REFCLK- | (differential pair) |
| 15 | PETn0 | pair, Lane 0 | GND | Ground |
| 16 | GND | Ground | PERp0 | Receiver differential |
| 17 | PRSNT2# | Hot-Plug presence detect | PERn0 | pair, Lane 0 |
| 18 | GND | Ground | GND | Ground |
| 19 | PETp1 | Transmitter differential | RSVD | Reserved |

Table 2.13 PCI Express x8 Connector Pinout (Part 1 of 2)

Notes

| Pin | Side A | | Side B | |
|-----|---------|--------------------------|--------|-----------------------|
| | | | | |
| 20 | PETn1 | pair, Lane 1 | GND | Ground |
| 21 | GND | Ground | PERp1 | Receiver differential |
| 22 | GND | Ground | PERn1 | pair, Lane 1 |
| 23 | PETp2 | Transmitter differential | GND | Ground |
| 24 | PETn2 | pair, Lane 2 | GND | Ground |
| 25 | GND | Ground | PERp2 | Receiver differential |
| 26 | GND | Ground | PERn2 | pair, Lane 2 |
| 27 | PETp3 | Transmitter differential | GND | Ground |
| 28 | PETn3 | pair, Lane 3 | GND | Ground |
| 29 | GND | Ground | PERp3 | Receiver differential |
| 30 | RSVD | Reserved | PERn3 | pair, Lane 3 |
| 31 | PRSNT2# | Hot-Plug presence detect | GND | Ground |
| 32 | GND | Ground | RSVD | Reserved |
| 33 | PETp4 | Transmitter differential | RSVD | Reserved |
| 34 | PETn4 | pair, Lane 4 | GND | Ground |
| 35 | GND | Ground | PERp4 | Receiver differential |
| 36 | GND | Ground | PERn4 | pair, Lane 4 |
| 37 | PETp5 | Transmitter differential | GND | Ground |
| 38 | PETn5 | pair, Lane 5 | GND | Ground |
| 39 | GND | Ground | PERp5 | Receiver differential |
| 40 | GND | Ground | PERn5 | pair, Lane 5 |
| 41 | PETp6 | Transmitter differential | GND | Ground |
| 42 | PETn6 | pair, Lane 6 | GND | Ground |
| 43 | GND | Ground | PERp6 | Receiver differential |
| 44 | GND | Ground | PERn6 | pair, Lane 6 |
| 45 | PETp7 | Transmitter differential | GND | Ground |
| 46 | PETn7 | pair, Lane 7 | GND | Ground |
| 47 | GND | Ground | PERp7 | Receiver differential |
| 48 | PRSNT2# | Hot-Plug presence detect | PERn7 | pair, Lane 7 |
| 49 | GND | Ground | GND | Ground |

Table 2.13 PCI Express x8 Connector Pinout (Part 2 of 2)

Note: These x8 PCI Express connectors comply with the PCIe specification. According to the PCI Express specification, the PRSNT1# pin should be wired to the farthest available PRSNT2# pin on the connector. In the EB24T3G2, all PRSNT2# pins are tied together. This allows a board with a x1 or a x4 width to be installed.

EB24T3G2 Board Figure

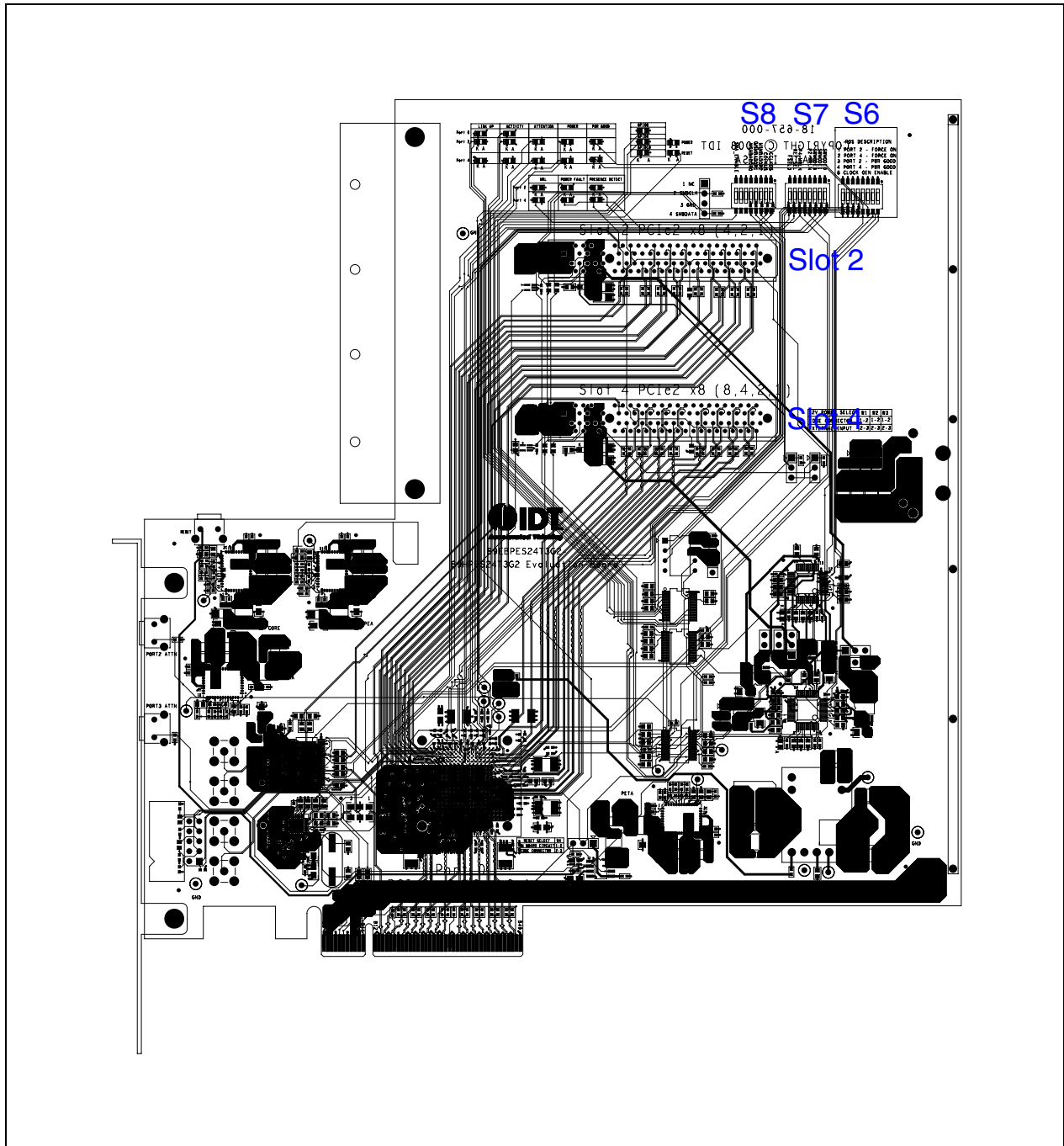



Software for the EB24T3G2 Eval Board

Notes

Introduction

This chapter discusses some of the main features of the available software to give users a better understanding of what can be achieved with the EB24T3G2 evaluation board using the device management software.

Device management software and related user documentation are available on a CD which is included in the Evaluation Board Kit. This information is also available on IDT's FTP site. For more information, contact IDT at ssdhelp@idt.com.

Device Management Software

The primary use of the Device Management Software package is to enable users of the evaluation board to access all the registers in the PES24T3G2 device. This access can be achieved using the PCI Express in-band configuration cycles through the upstream port on the PES24T3G2.

This software also enables users to save a snapshot of the current register set into a dump file which can be used for debugging purposes. An export/import facility is also available to create and use "Configuration" files which can be used to initialize the switch device with specific values in specific registers.

A conversion utility is also provided to translate a configuration file into an EEPROM programmable data structure. This enables the user to program an appropriate serial EEPROM with desirable register settings for the PES24T3G2, and then to populate that EEPROM onto the Evaluation Board. It is also possible to program the EEPROM directly on the Evaluation Board using a feature provided by the software package.

The front end of the Device Management Software is a user-friendly Graphical User Interface which allows the user to quickly read or write the registers of interest. The GUI also permits the user to run the software in "simulation" mode with no real hardware attached, allowing the creation of configuration files for the PES24T3G2 in the absence of the actual device.

Much of the Device Management Software is written with device-independent and OS-independent code. The software will be guaranteed to work on Linux (/sys interface) and MS Windows XP. It may function flawlessly on various flavors of MS Windows, but may not be validated on all. The fact that the software is device-independent assures its scalability to future PCIe parts from IDT. Once users are familiar with the GUI, they will be able to use the same GUI on all PCIe parts from IDT. This software is customized for each device through an XML device description file which includes information on the number of ports, registers, types of registers, information on bit-fields within each register, etc.

Notes



Schematics

Notes

Schematics

89BPES24T3G2 – 89HPES24T3G2 Evaluation Board

| REVISIONS | | | | |
|-------------|-----|-----------------|------------|-----------|
| DCN | REV | DESCRIPTION | DATE | CHANGE BY |
| PCB-0148R01 | 1.0 | INITIAL RELEASE | 2008-01-17 | T. TRAN |
| | | | | |
| | | | | |

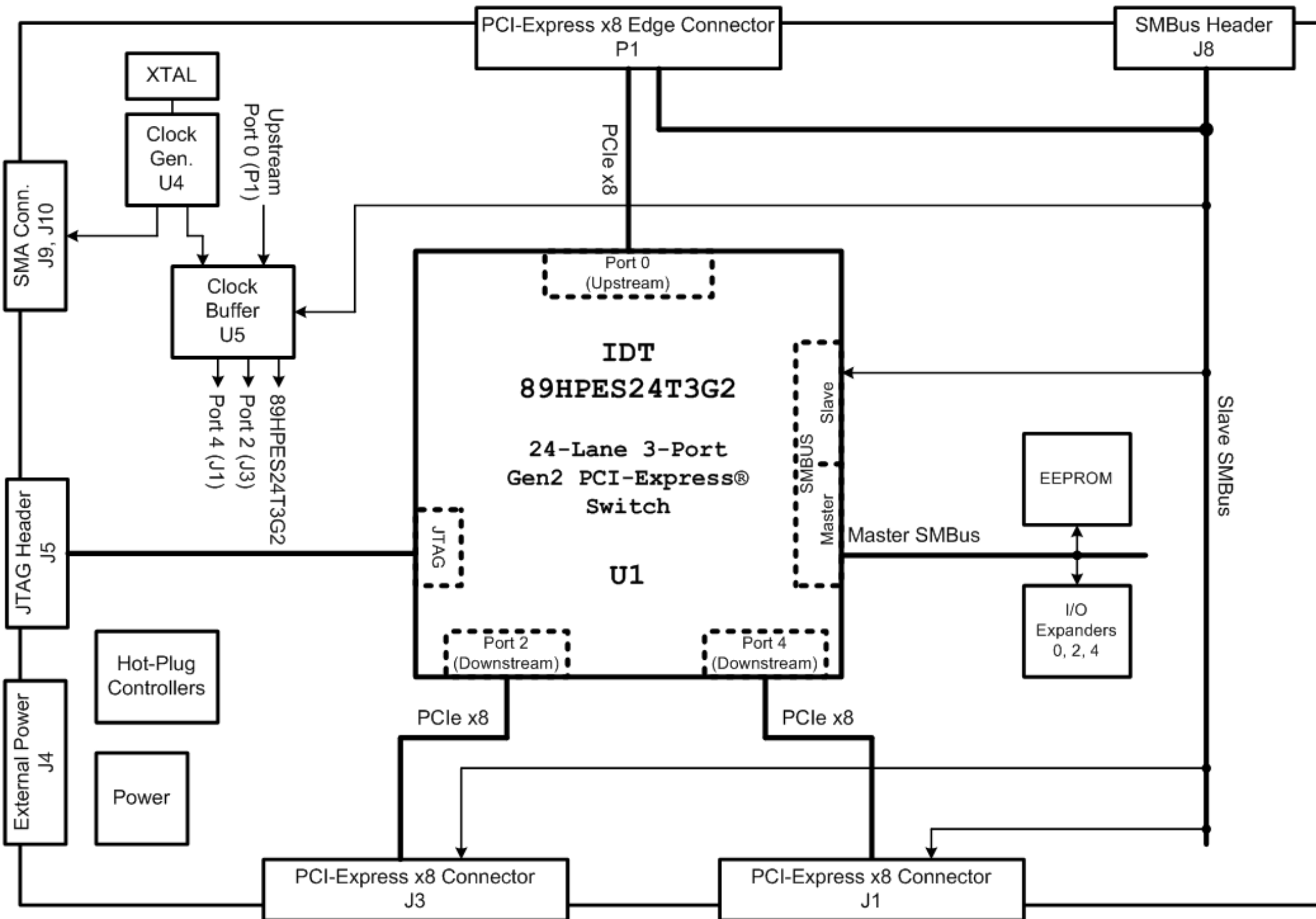

SHEET DESCRIPTION

- 1 TITLE PAGE
- 2 RESET, POWER CONNECTOR
- 3 POWER REGULATORS
- 4 CLOCKS
- 5 I/O EXP, WAKE, ATTN
- 6 HOT PLUG CONTROLLERS
- 7 HOT PLUG – MOSFETS
- 8 PORT 0 EDGE CONN (U/S)
- 9 PORT 2 CONNECTOR (D/S)
- 10 PORT 4 CONNECTOR (D/S)
- 11 PES24T3G2 – EEPROM, JTAG
- 12 PES24T3G2 – POWER



CONFIDENTIAL PROPERTY OF INTEGRATED DEVICE TECHNOLOGY, INC.
6024 SILVER CREEK VALLEY RD. SAN JOSE, CA 95138
COPYRIGHT (C) IDT2008

| | | | |
|----------------------------|--------------------------|-----------------------|---------------|
| TITLE 89BPES24T3G2 | | | |
| SIZE B | DRAWING NO. SCH-00146 | FAB P/N 18-657-000 | REV. 1.0 |
| AUTHOR K Leung / T Tran | | CHECKED BY D Huang | |
| Thu Jan 17 16:48:53 2008 | | | SHEET 1 OF 12 |

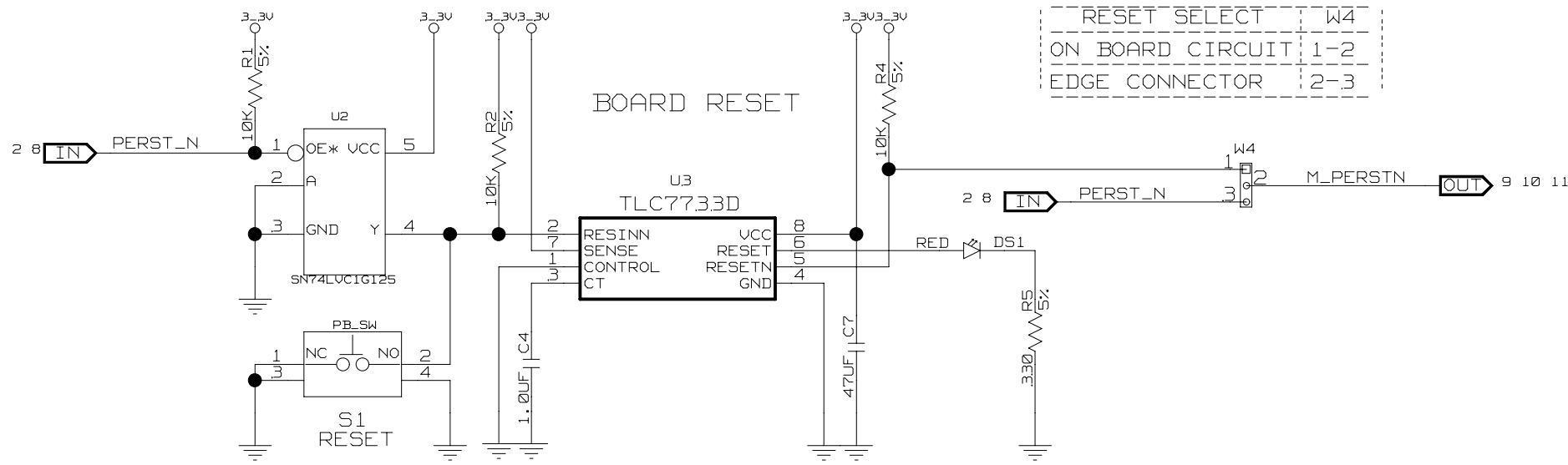

SILKSCREEN TABLE

| | |
|------------------|-----|
| RESET SELECT | W4 |
| ON BOARD CIRCUIT | 1-2 |
| EDGE CONNECTOR | 2-3 |

POWER INDICATOR
PLACE NEAR TOP EDGE
LABEL 'POWER'

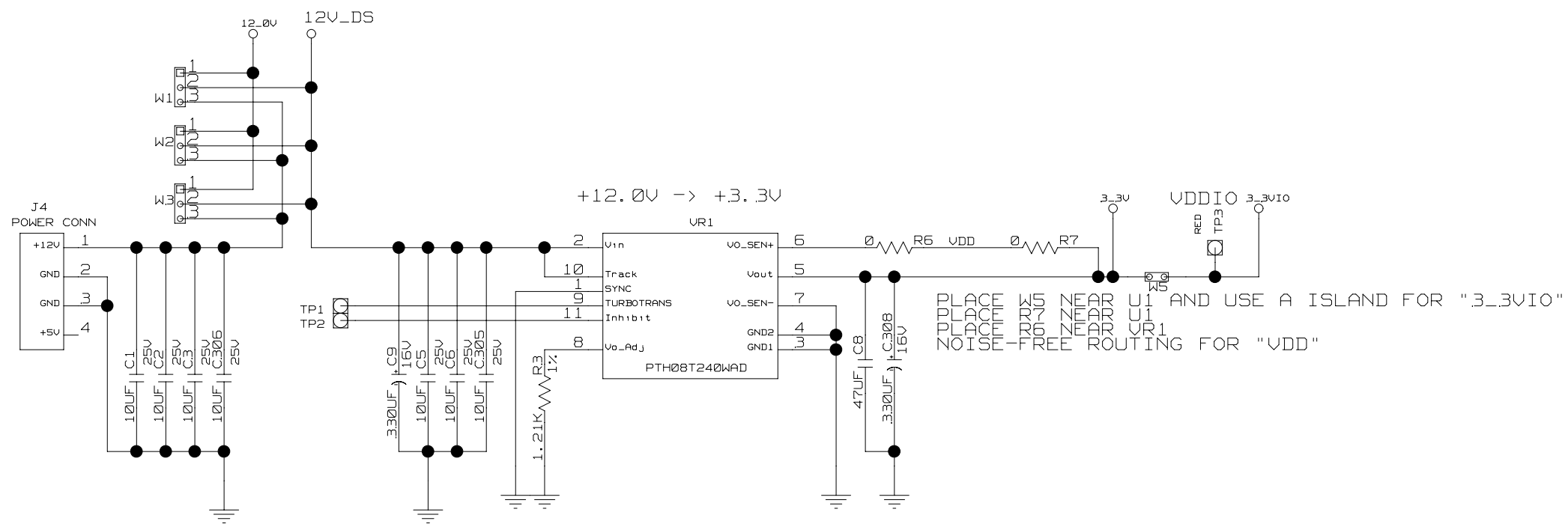
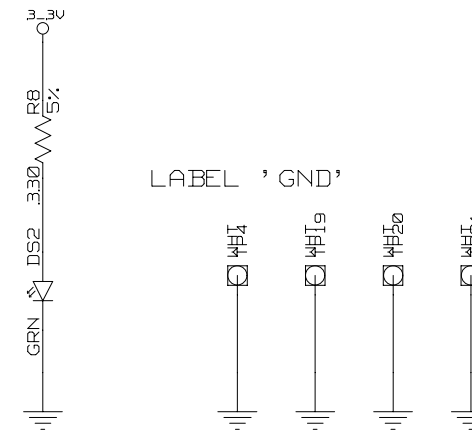

SILKSCREEN TABLE

| | | | |
|------------------|-----|-----|-----|
| 12V POWER SELECT | W1 | W2 | W3 |
| EDGE CONNECTOR | 1-2 | 1-2 | 1-2 |
| EXTERNAL INPUT | 2-3 | 2-3 | 2-3 |



CONFIDENTIAL PROPERTY OF INTEGRATED DEVICE TECHNOLOGY, INC.
6024 SILVER CREEK VALLEY RD. SAN JOSE, CA 95138
COPYRIGHT (C) IDT2008

| | | | |
|--------------------------|-------------|------------|---------------|
| TITLE 89EBPES24T3G2 | | | |
| RESET, POWER CONNECTOR | | | |
| SIZE | DRAWING NO. | FAB P/N | REV. |
| B | SCH-00146 | 18-657-000 | 1.0 |
| AUTHOR | | CHECKED BY | |
| K Leung / T Tran | | D Huang | |
| Thu Jan 17 16:46:18 2008 | | | SHEET 2 OF 12 |

SILKSCREEN TEXT: CORE

SILKSCREEN TEXT: PETA

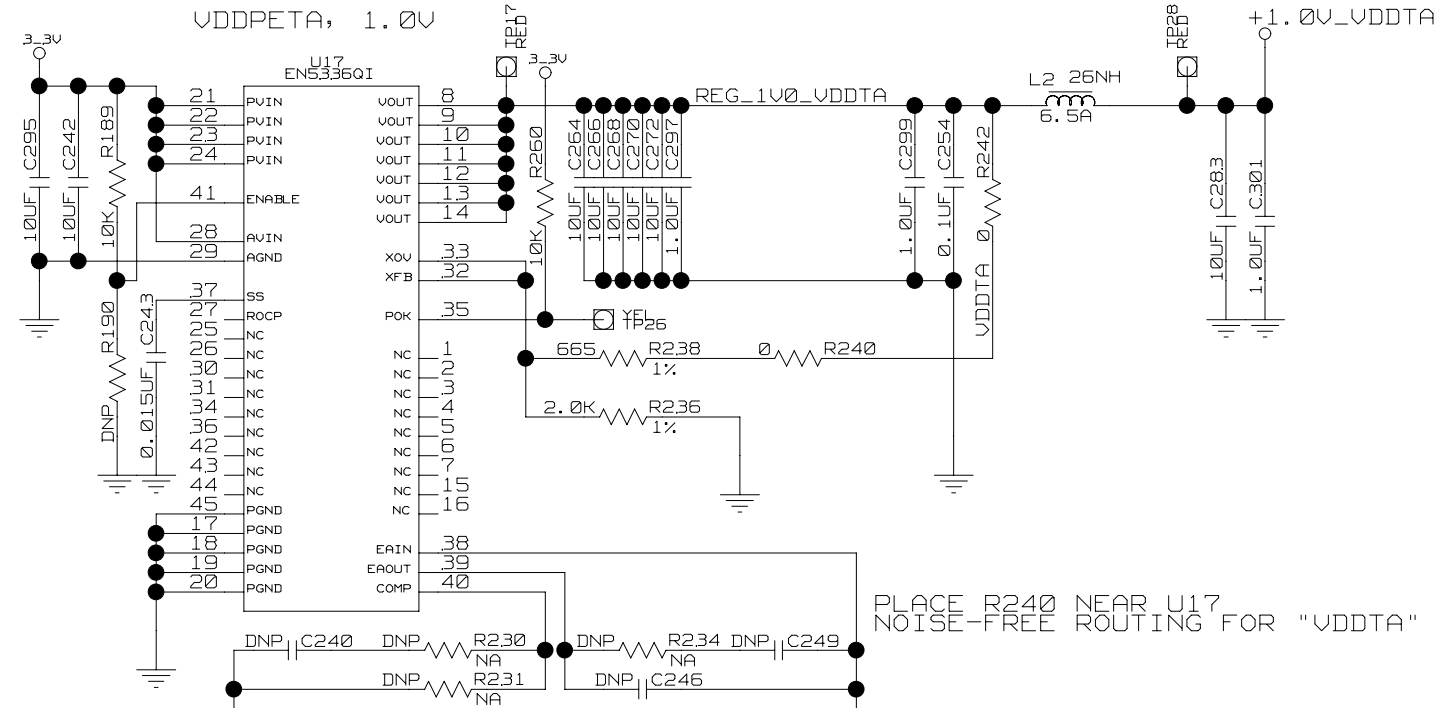
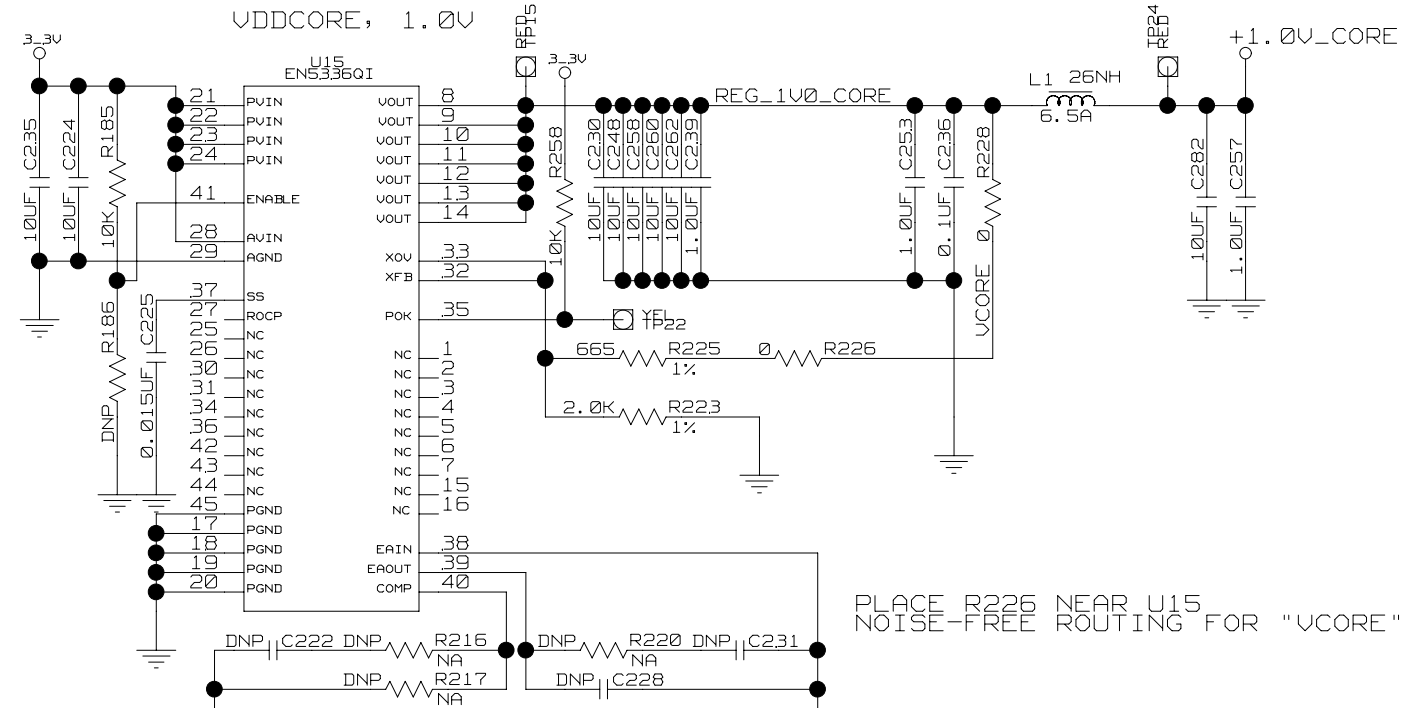

SILKSCREEN TEXT: PEA

SILKSCREEN TEXT: PEHA

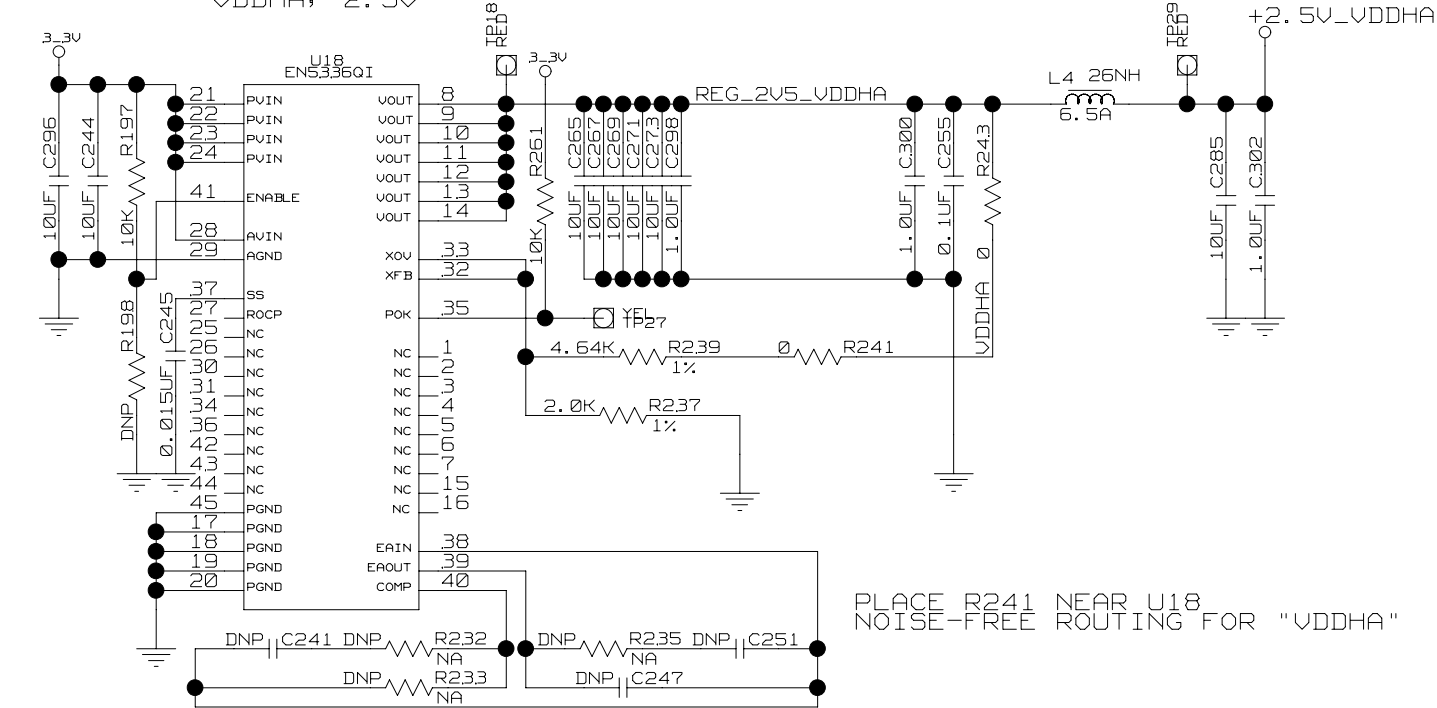
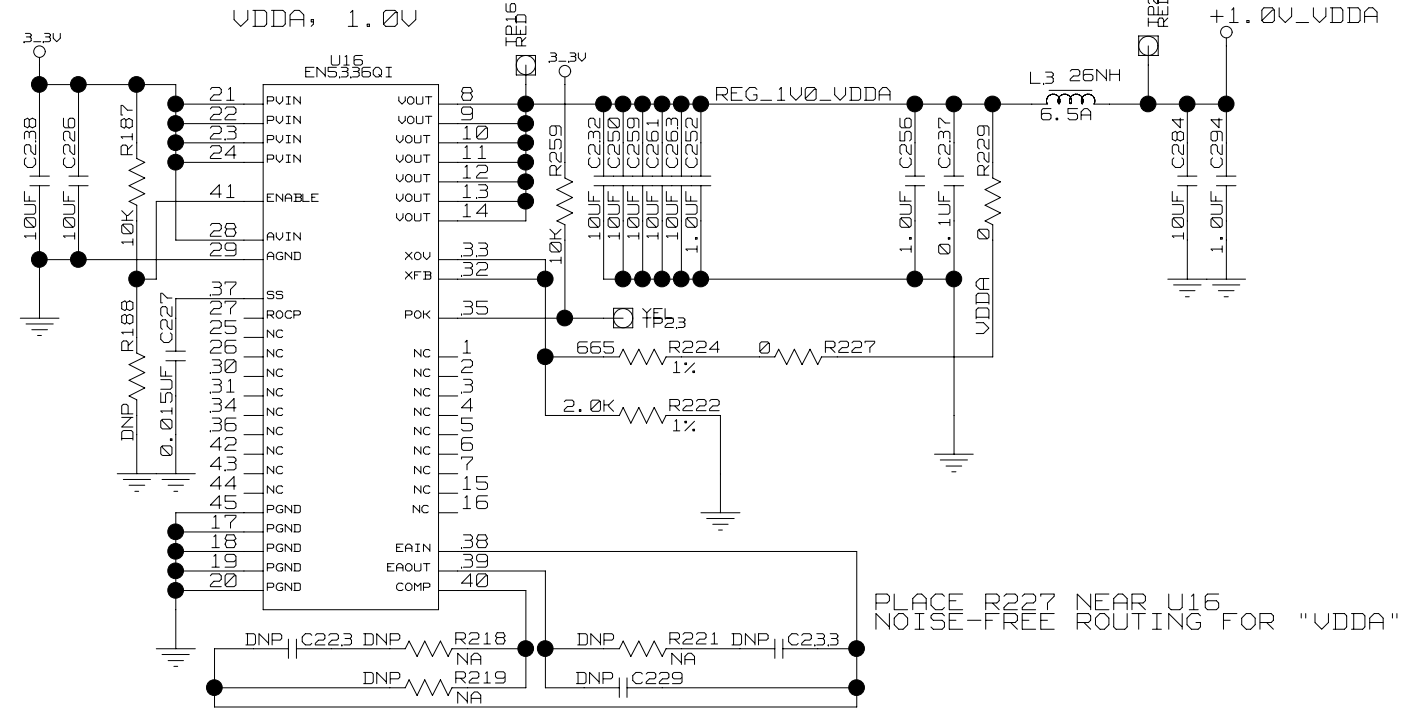

NOTE:
ALL POWER NETS USE PLANE OR WIDE TRACE



CONFIDENTIAL PROPERTY OF INTEGRATED DEVICE TECHNOLOGY, INC.
6024 SILVER CREEK VALLEY RD. SAN JOSE, CA 95138
COPYRIGHT (C) IDT2008

| | | | |
|--------------------------|-----------------------|--------------------|---------------|
| TITLE 89EBPES24T3G2 | | | |
| POWER REGULATORS | | | |
| SIZE B | DRAWING NO. SCH-00146 | FAB P/N 18-657-000 | REV. 1.0 |
| AUTHOR K Leung / T Tran | | CHECKED BY D Huang | |
| Thu Jan 17 16:46:23 2008 | | | SHEET 3 OF 12 |

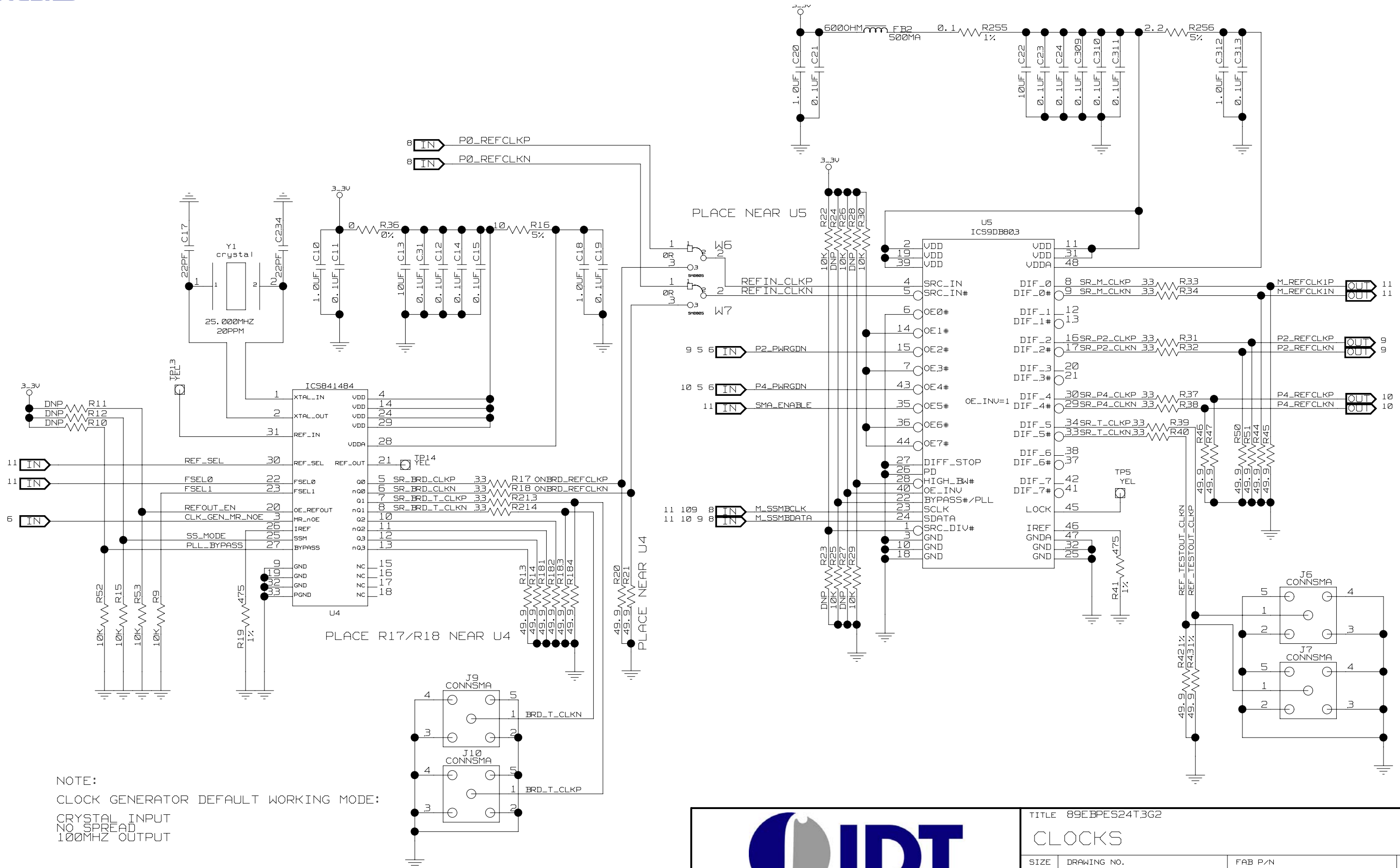

NOTE:
 CLOCK GENERATOR DEFAULT WORKING MODE:
 CRYSTAL INPUT
 NO SPREAD
 100MHZ OUTPUT

CONFIDENTIAL PROPERTY OF INTEGRATED DEVICE TECHNOLOGY, INC.
 6024 SILVER CREEK VALLEY RD. SAN JOSE, CA 95138
 COPYRIGHT (C) IDT2008

| | | | |
|--------------------------|-------------|------------|---------------|
| TITLE 89EBPES24T3G2 | | | |
| CLOCKS | | | |
| SIZE | DRAWING NO. | FAB P/N | REV. |
| B | SCH-00146 | 18-657-000 | 1.0 |
| AUTHOR | | CHECKED BY | |
| K Leung / T Tran | | D Huang | |
| Thu Jan 17 16:46:36 2008 | | | SHEET 4 OF 12 |

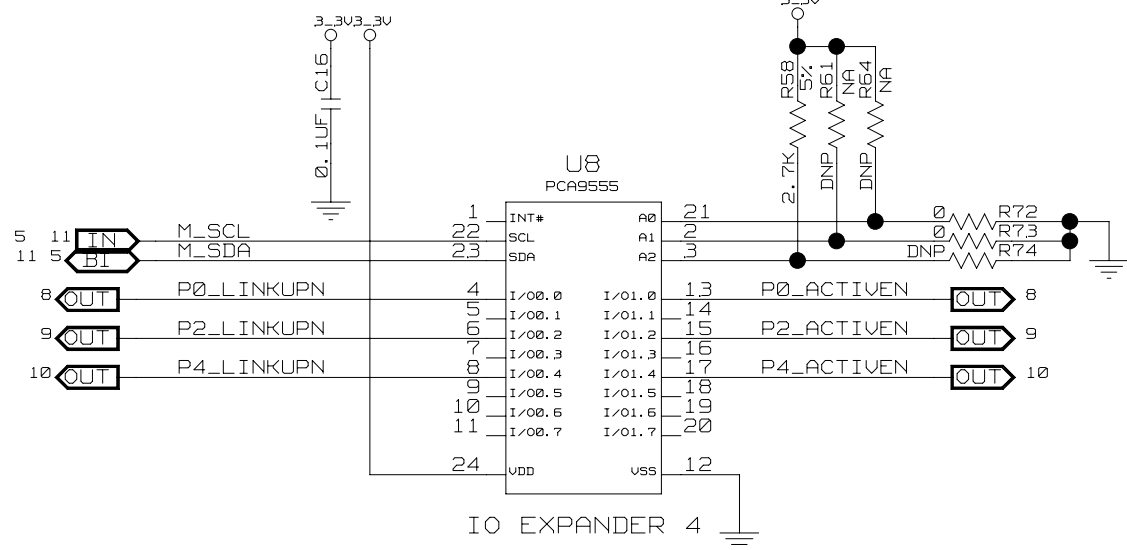
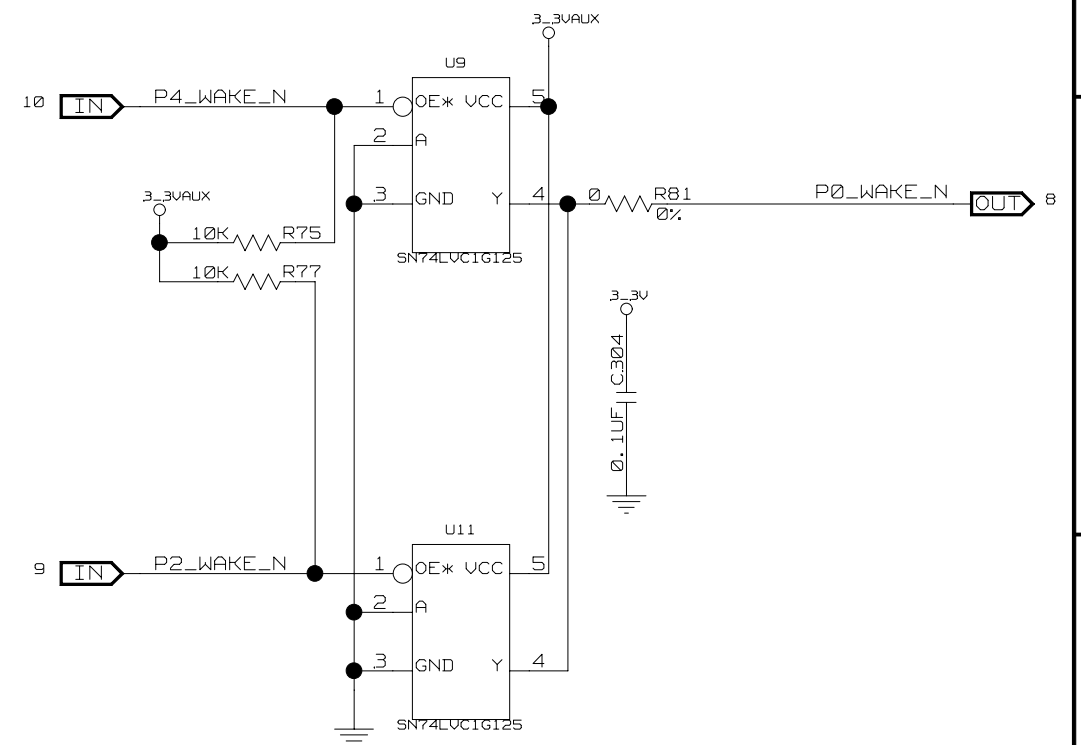
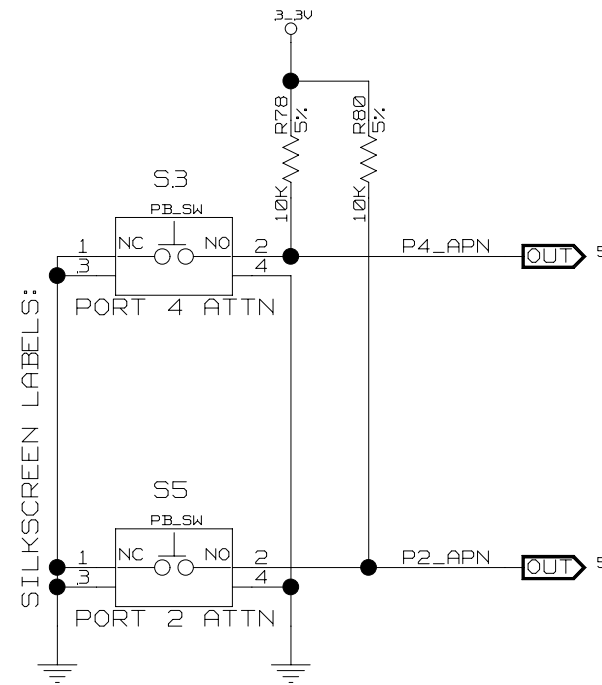
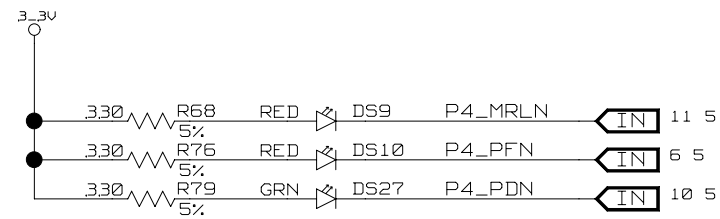
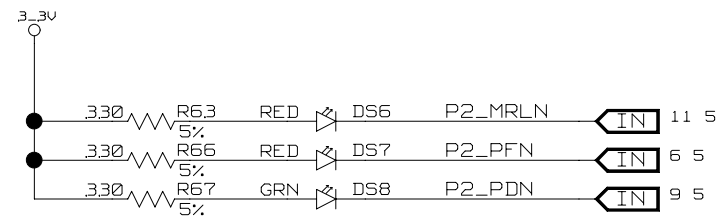
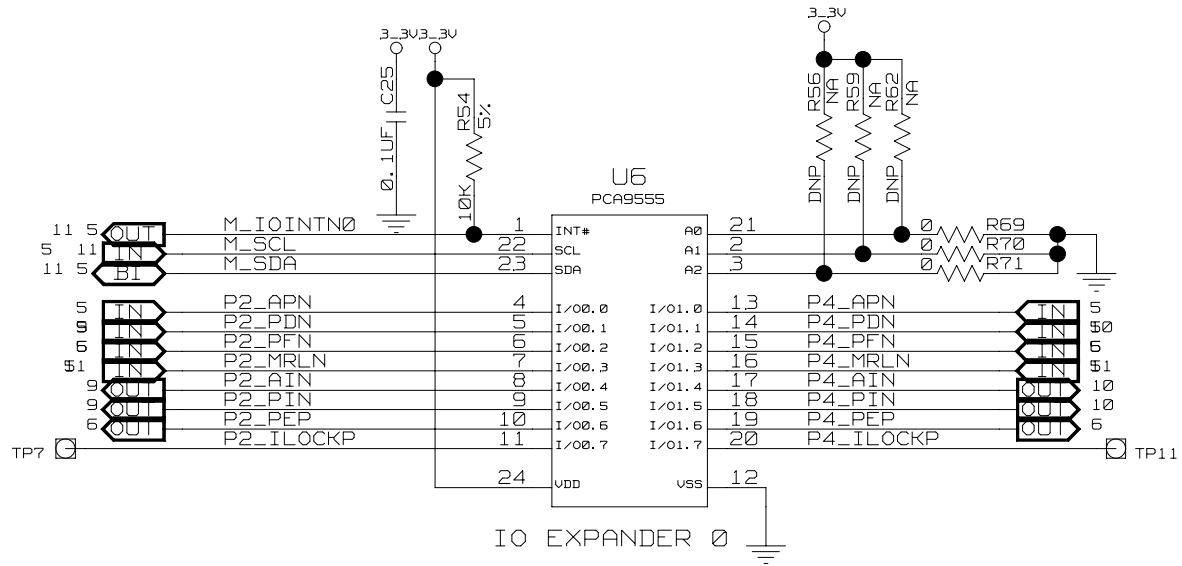

| | | | |
|---|-----------------------|--|----------|
| | | TITLE 89EBPES24T3G2 | |
| | | IO EXP, WAKE, ATTN BUTTONS | |
| SIZE B | DRAWING NO. SCH-00146 | FAB P/N 18-657-000 | REV. 1.0 |
| AUTHOR K Leung / T Tran | | CHECKED BY D Huang | |
| CONFIDENTIAL PROPERTY OF INTEGRATED DEVICE TECHNOLOGY, INC. 6024 SILVER CREEK VALLEY RD. SAN JOSE, CA 95138 COPYRIGHT (C) IDT2008 | | Thu Jan 17 16:46:40 2008 SHEET 5 OF 12 | |

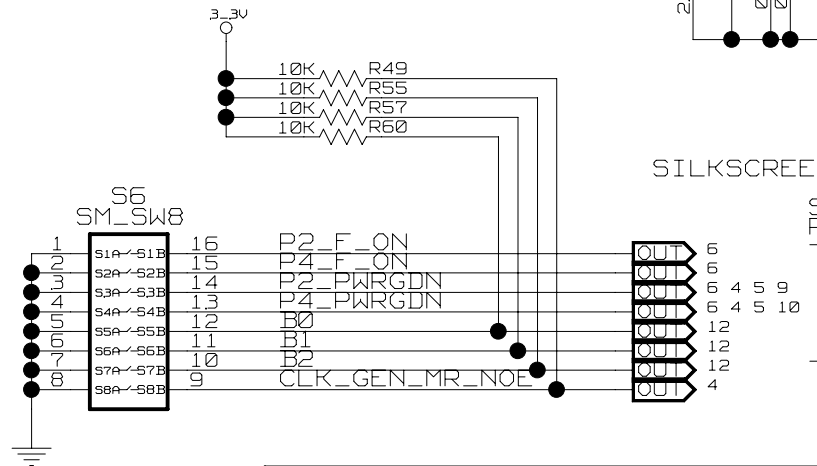
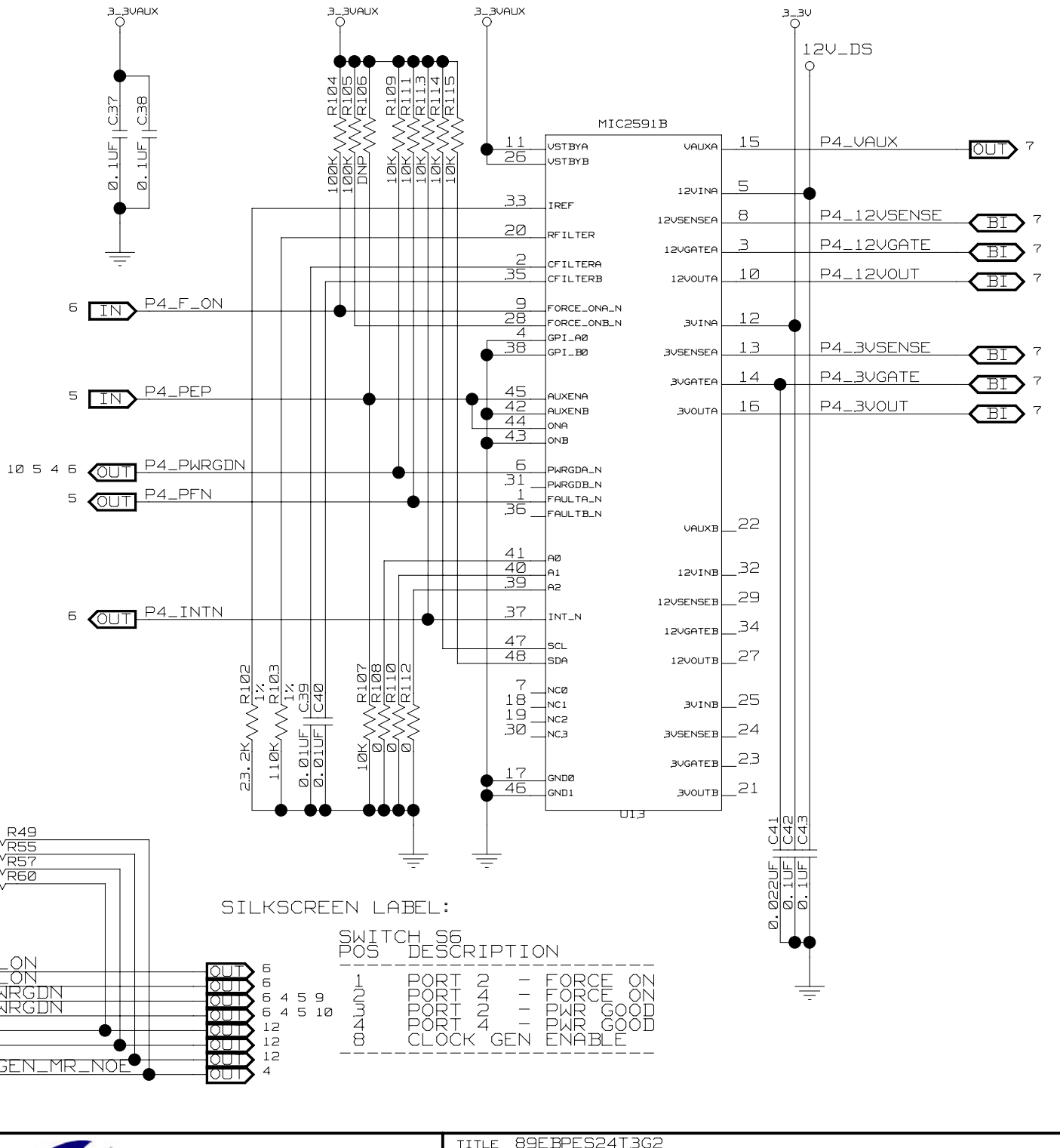
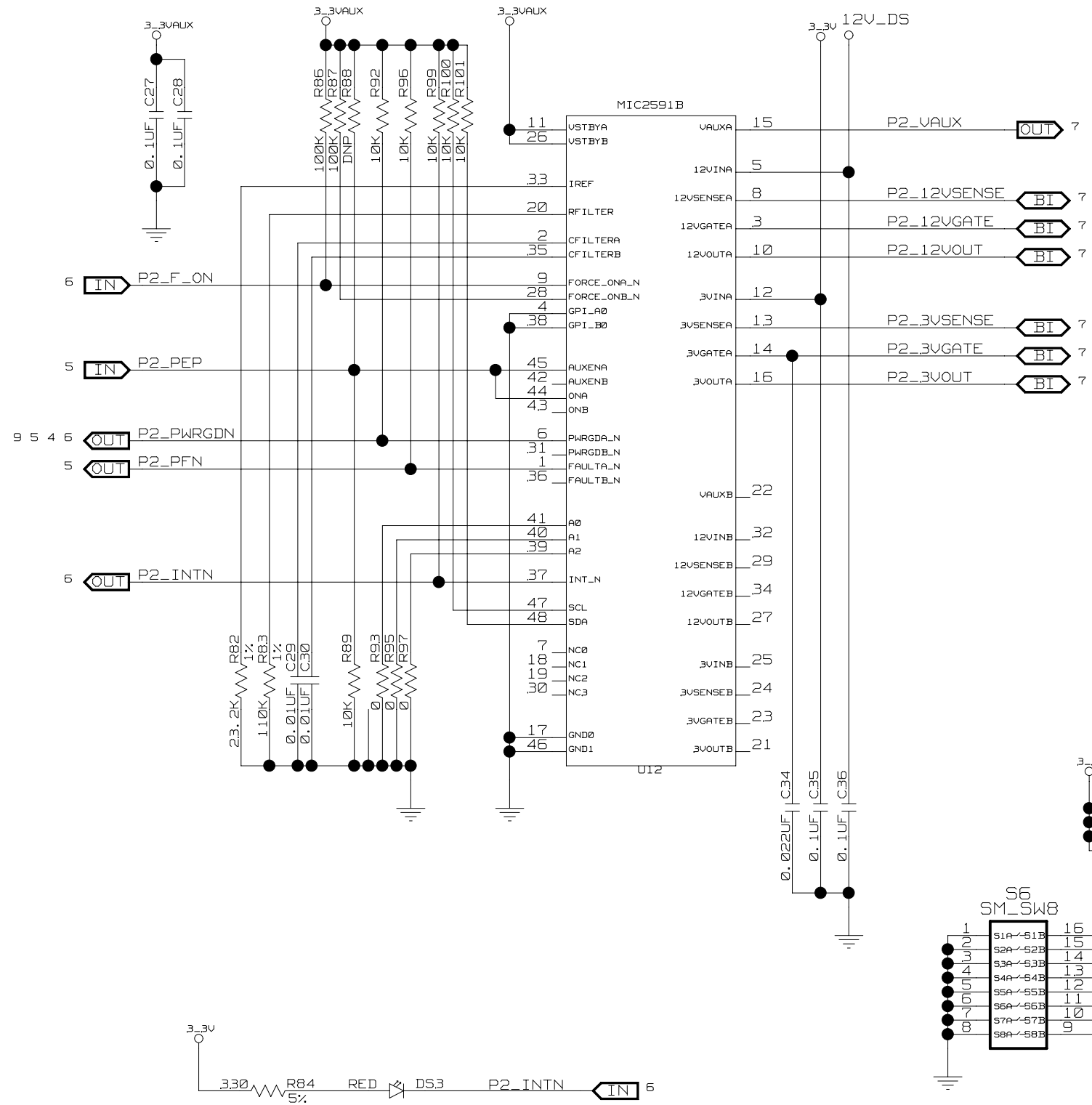

SILKSCREEN LABEL:

| PORT | DESCRIPTION |
|-----------|-------------|
| PORT 2 | FORCE ON |
| PORT 4 | FORCE ON |
| PORT 2 | PWR GOOD |
| PORT 4 | PWR GOOD |
| CLOCK GEN | ENABLE |

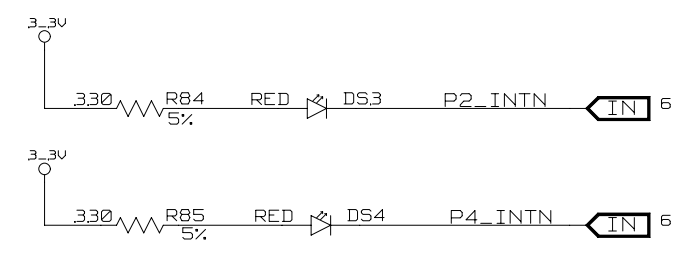

TITLE 89EBPES24T3G2

HOT PLUG CONTROLLERS

| | | | |
|--------------------------|-------------|------------|---------------|
| SIZE | DRAWING NO. | FAB P/N | REV. |
| B | SCH-00146 | 18-657-000 | 1.0 |
| AUTHOR | | CHECKED BY | |
| K Leung / T Tran | | D Huang | |
| Thu Jan 17 16:46:42 2008 | | | SHEET 6 OF 12 |

CONFIDENTIAL PROPERTY OF INTEGRATED DEVICE TECHNOLOGY, INC.
6024 SILVER CREEK VALLEY RD. SAN JOSE, CA 95138
COPYRIGHT (C) IDT2008

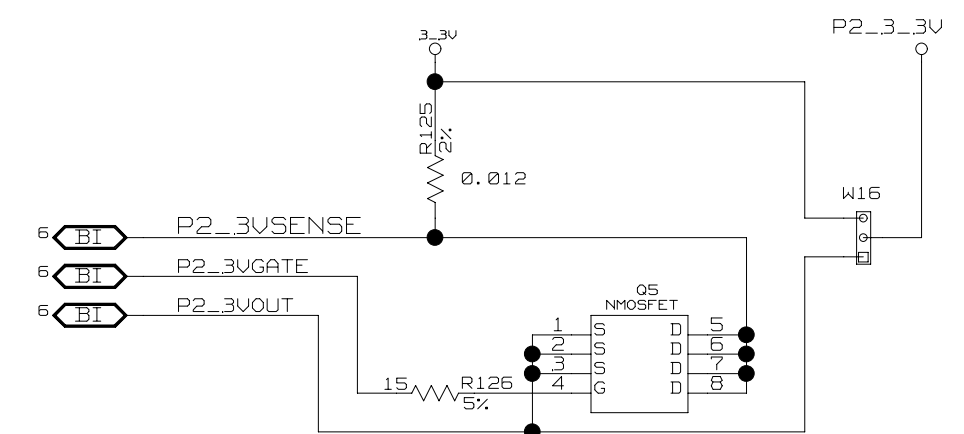
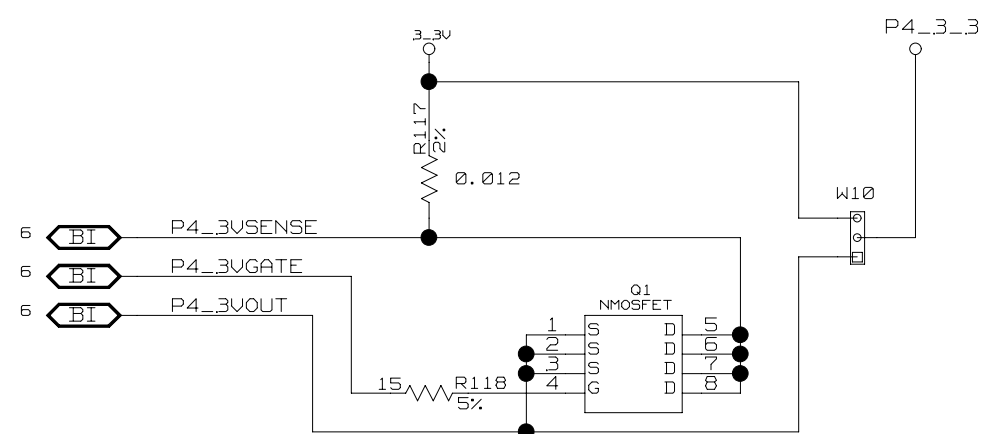
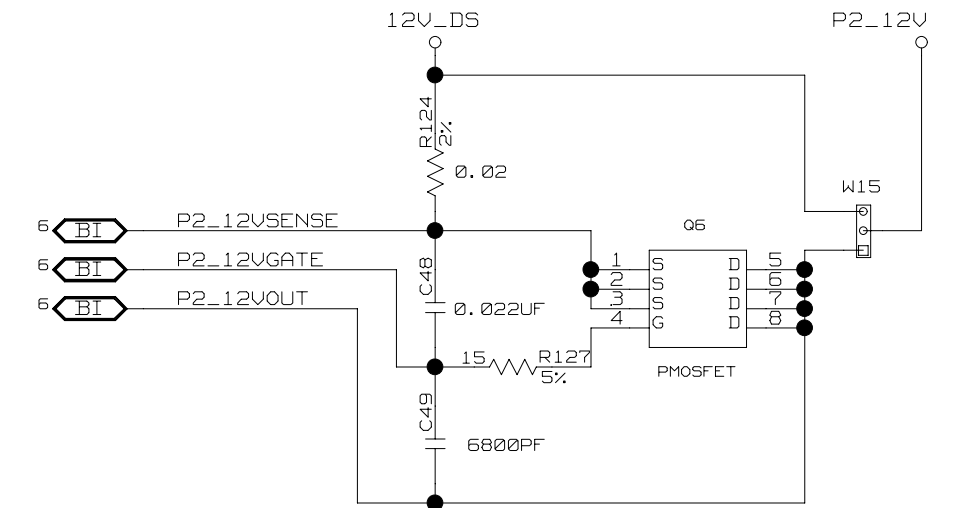
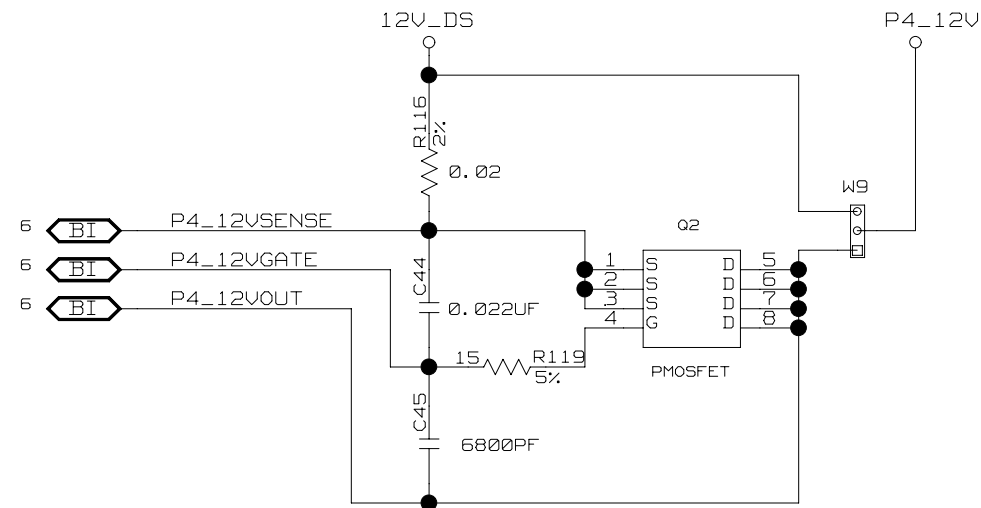
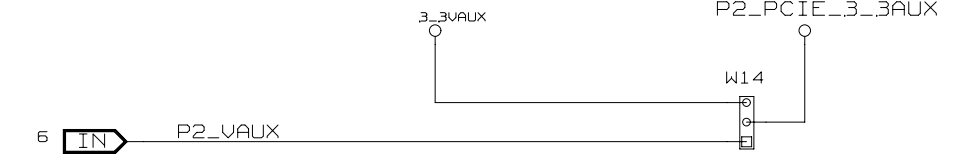
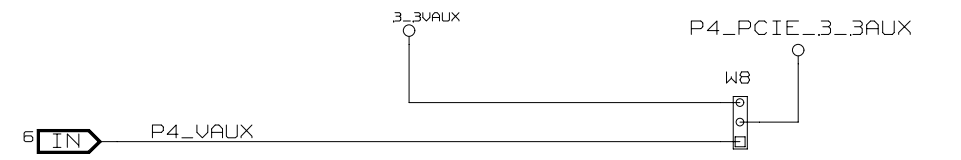

NOTE:
USE PLANE OR WIDE TRACE FOR ALL POWER NETS



CONFIDENTIAL PROPERTY OF INTEGRATED DEVICE TECHNOLOGY, INC.
6024 SILVER CREEK VALLEY RD. SAN JOSE, CA 95138
COPYRIGHT (C) IDT2008

| | | | |
|--------------------------|-------------|------------|---------------|
| TITLE 89EBPES24T3G2 | | | |
| HOT PLUG - MOSFETS | | | |
| SIZE | DRAWING NO. | FAB P/N | REV. |
| B | SCH-00146 | 18-657-000 | 1.0 |
| AUTHOR | | CHECKED BY | |
| K Leung / T Tran | | D Huang | |
| Thu Jan 17 16:46:47 2008 | | | SHEET 7 OF 12 |

LABEL PINS:

4 SMBDATA
 1 GND
 2 SMBCLK
 3 NC

11 109 4
 4 11 10 9

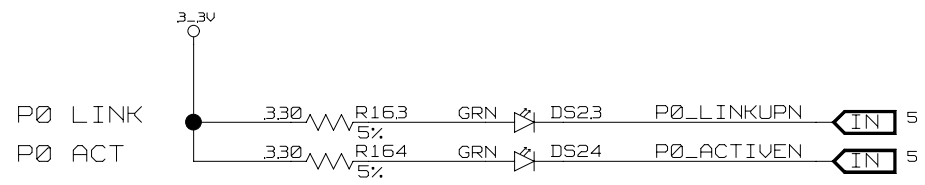
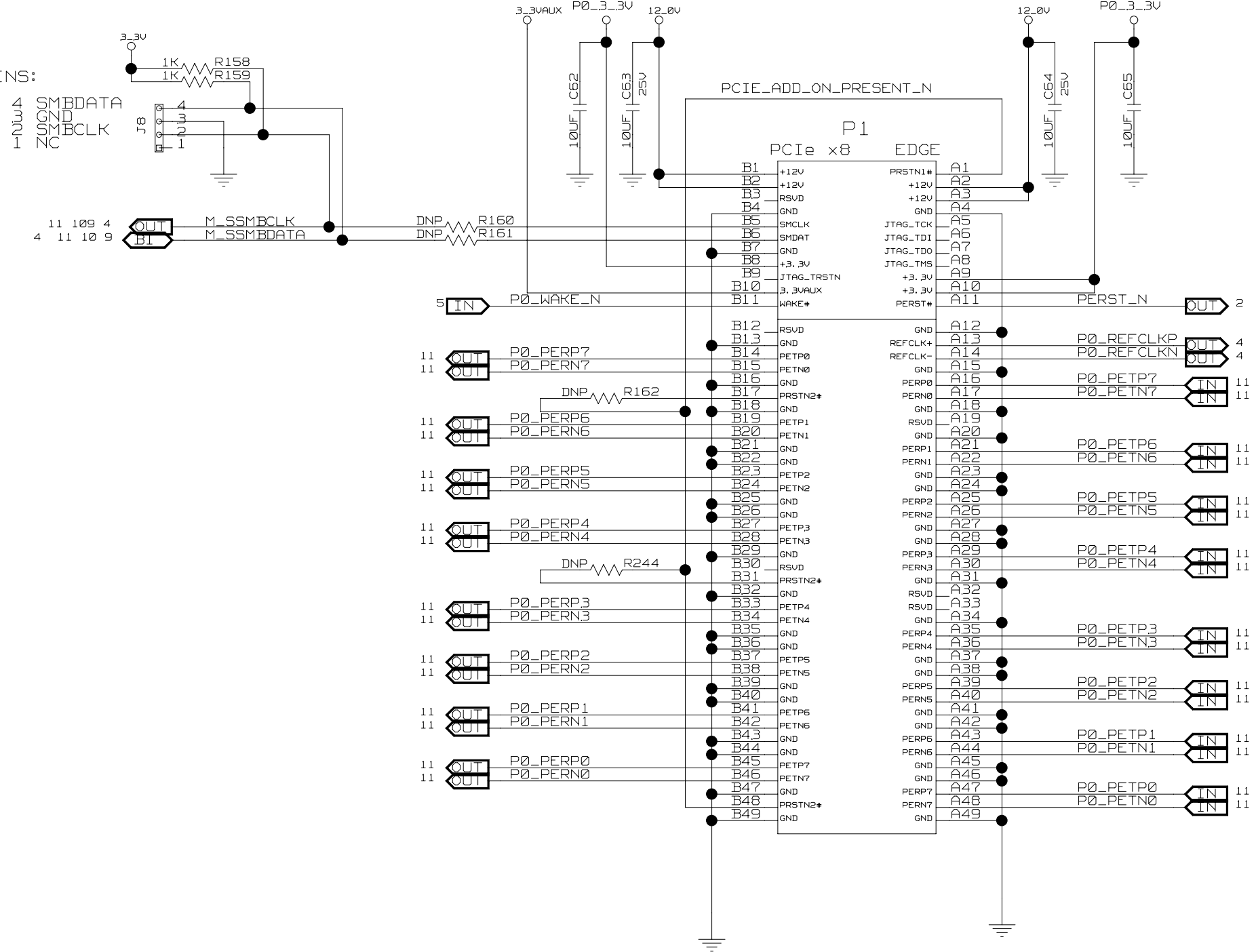

| | | | |
|----------------------------|-------------|------------|---------------|
| TITLE 89EBPES24T3G2 | | | |
| PORT 0 UPSTREAM EDGE CONN. | | | |
| SIZE | DRAWING NO. | FAB P/N | REV. |
| B | SCH-00146 | 18-657-000 | 1.0 |
| AUTHOR | | CHECKED BY | |
| K Leung / T Tran | | D Huang | |
| Thu Jan 17 16:46:50 2008 | | | SHEET 8 OF 12 |

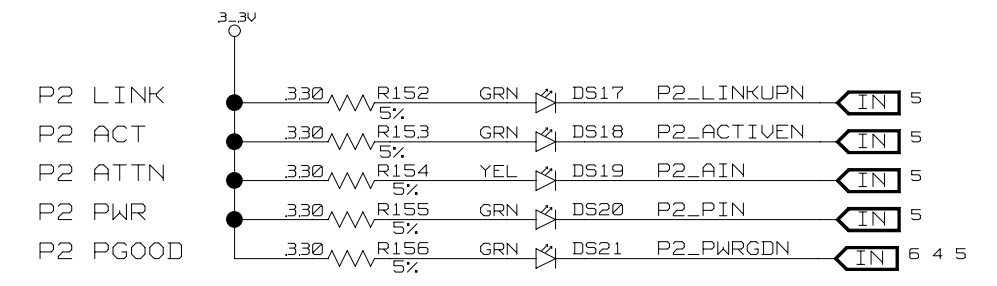
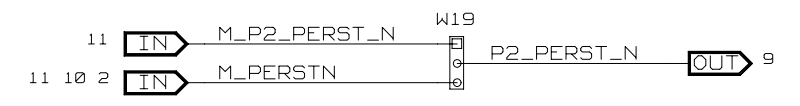
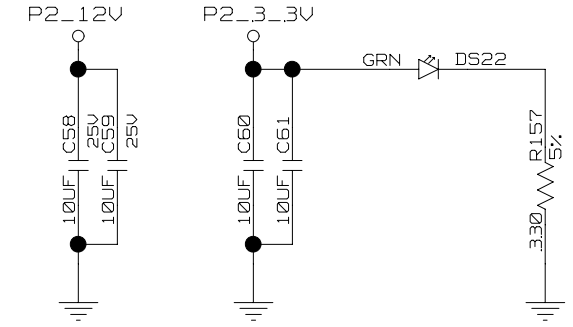
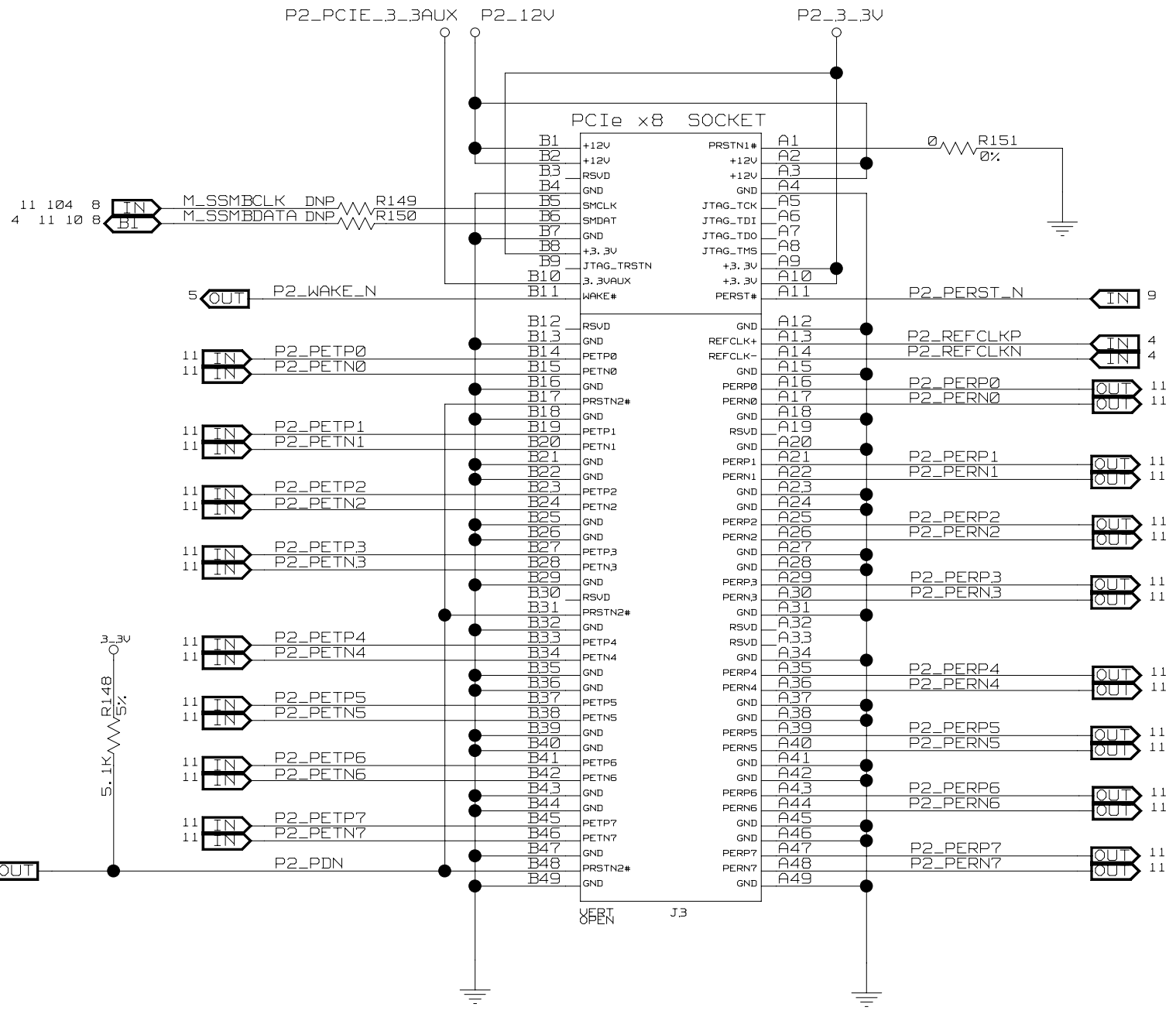

CONFIDENTIAL PROPERTY OF INTEGRATED DEVICE TECHNOLOGY, INC.
 6024 SILVER CREEK VALLEY RD. SAN JOSE, CA 95138
 COPYRIGHT (C) IDT2008

| | | | |
|--------------------------|-------------|------------|---------------|
| TITLE 89EBPES24T3G2 | | | |
| PORT 2 CONNECTOR | | | |
| SIZE | DRAWING NO. | FAB P/N | REV. |
| B | SCH-00146 | 18-657-000 | 1.0 |
| AUTHOR | | CHECKED BY | |
| K Leung / T Tran | | D Huang | |
| Thu Jan 17 16:46:55 2008 | | | SHEET 9 OF 12 |

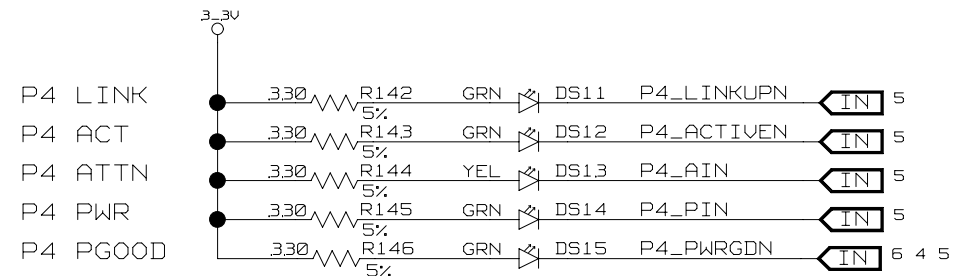
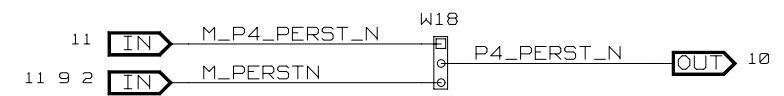
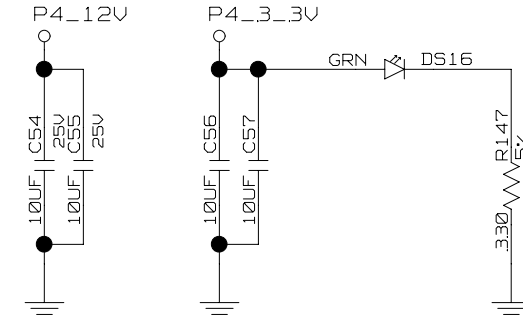
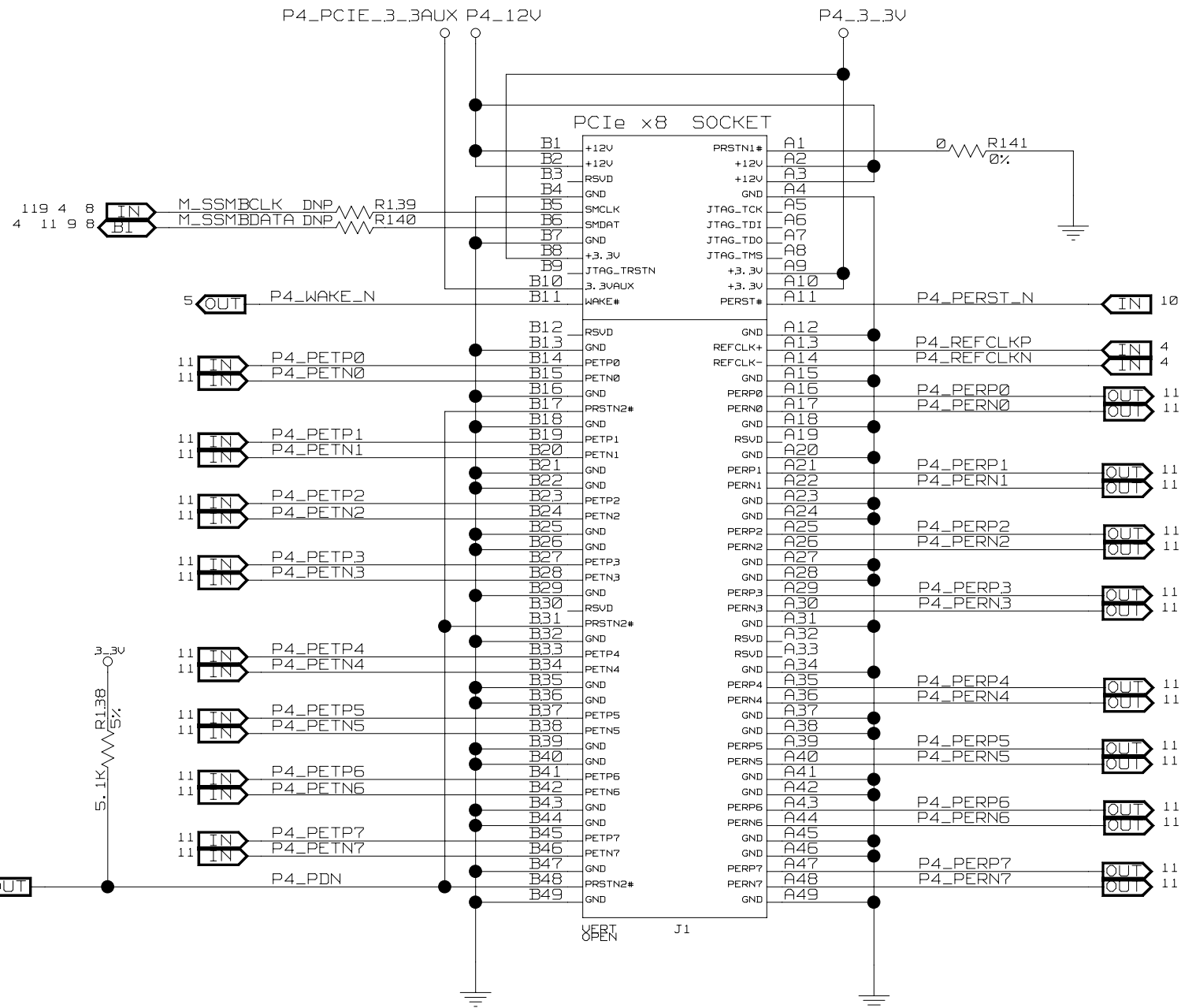

CONFIDENTIAL PROPERTY OF INTEGRATED DEVICE TECHNOLOGY, INC.
 6024 SILVER CREEK VALLEY RD. SAN JOSE, CA 95138
 COPYRIGHT (C) IDT2008

| | | | |
|----------------------------|--------------------------|-----------------------|----------------|
| TITLE 89EBPES24T3G2 | | | |
| PORT 4 CONNECTOR | | | |
| SIZE B | DRAWING NO. SCH-00146 | FAB P/N 18-657-000 | REV. 1.0 |
| AUTHOR K Leung / T Tran | | CHECKED BY D Huang | |
| Thu Jan 17 16:46:58 2008 | | | SHEET 10 OF 12 |

89HPES24T3G2 (2 of 3)

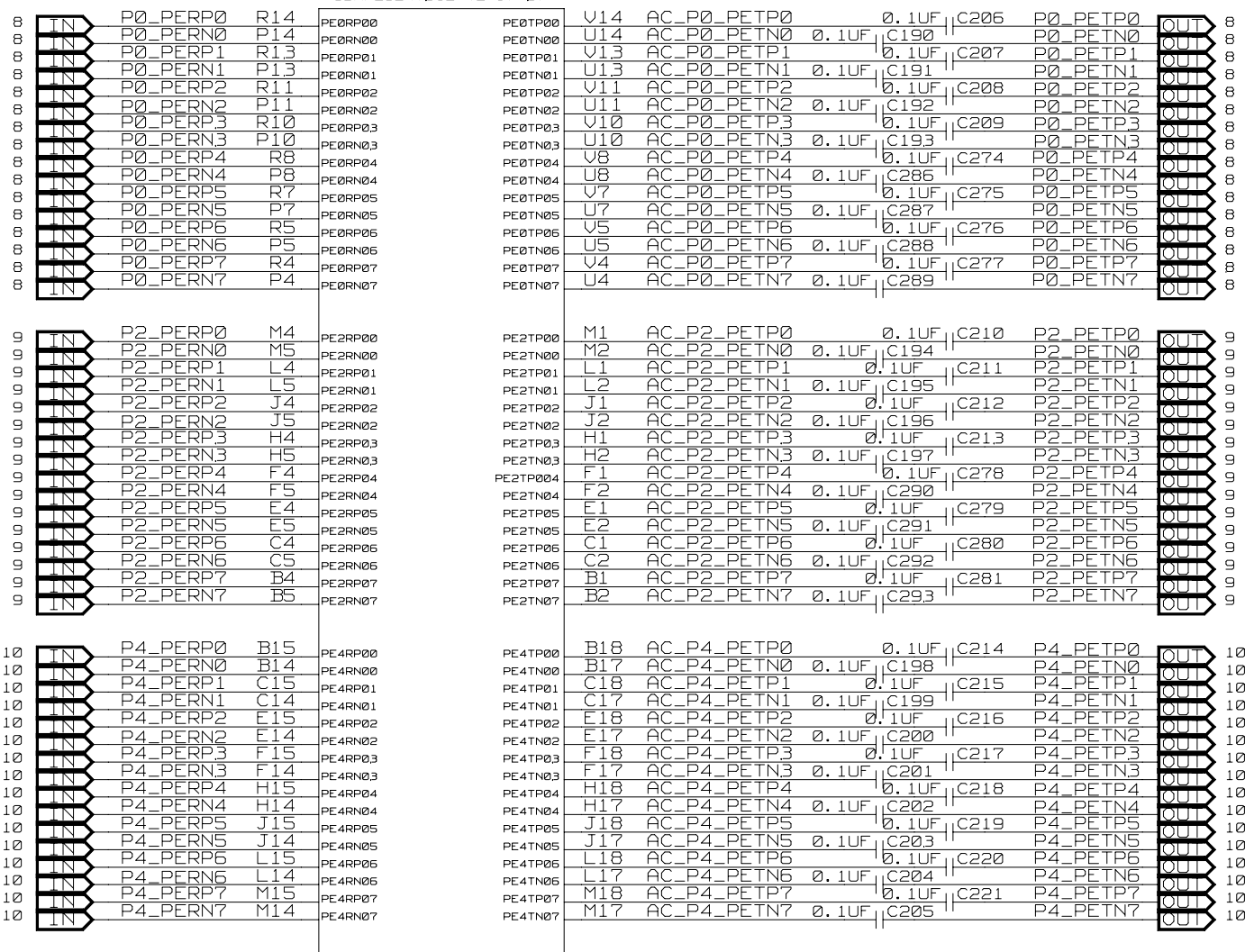

U1

NOTE:
PLACE ALL AC COUPLING CAPACITORS NEAR
EDGE CONNECTOR OR DOWNSTREAM SLOTS

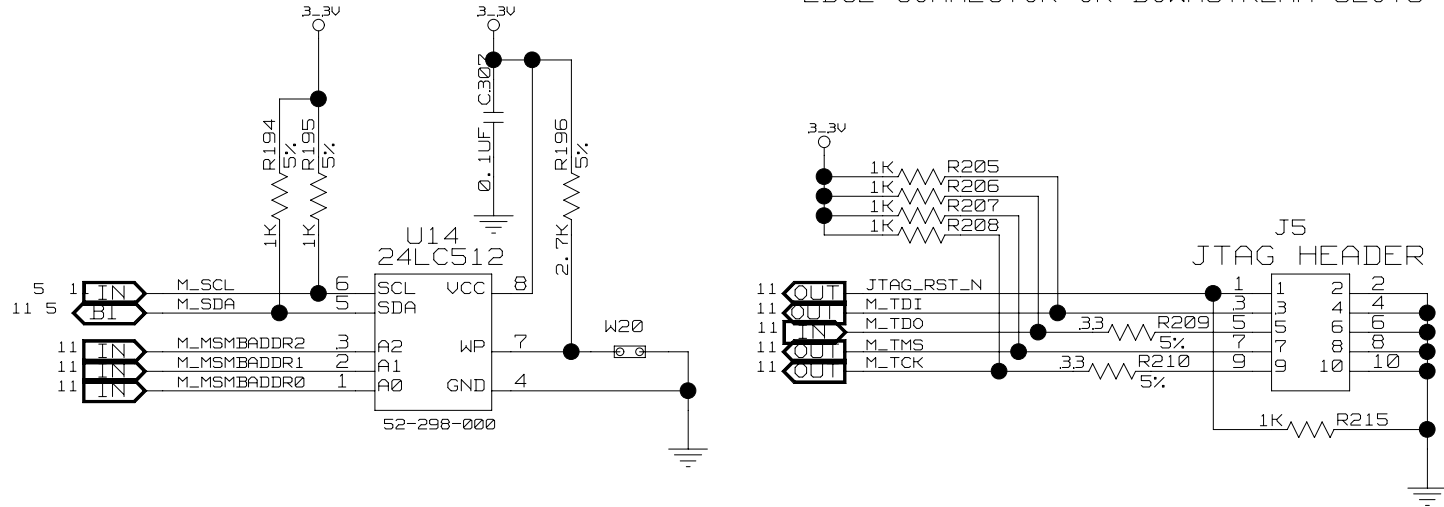

89HPES24T3G2 (1 of 3)

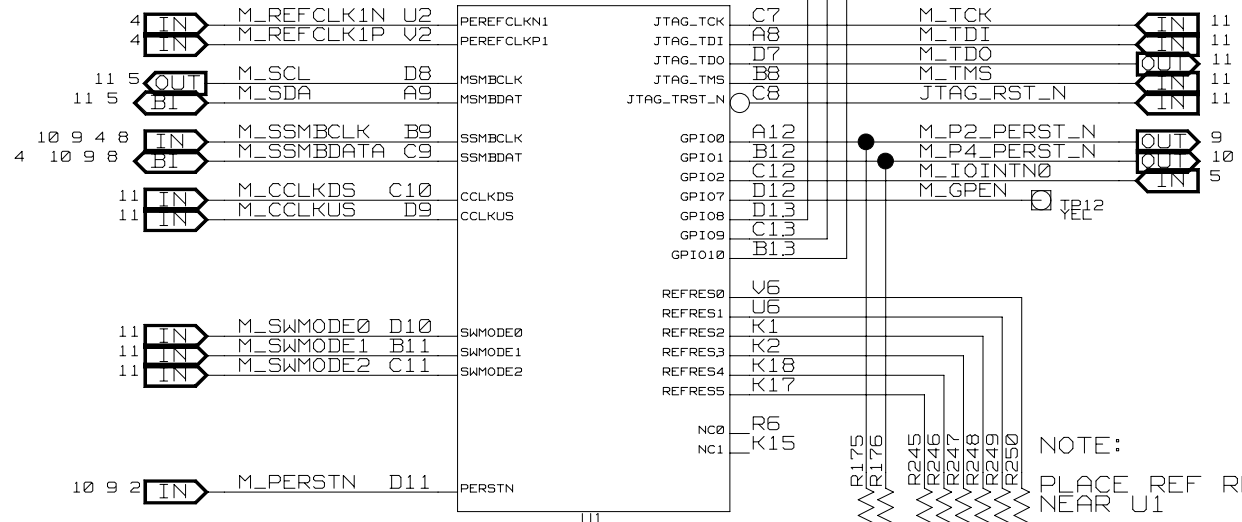

NOTE:
PLACE REF RES
NEAR U1

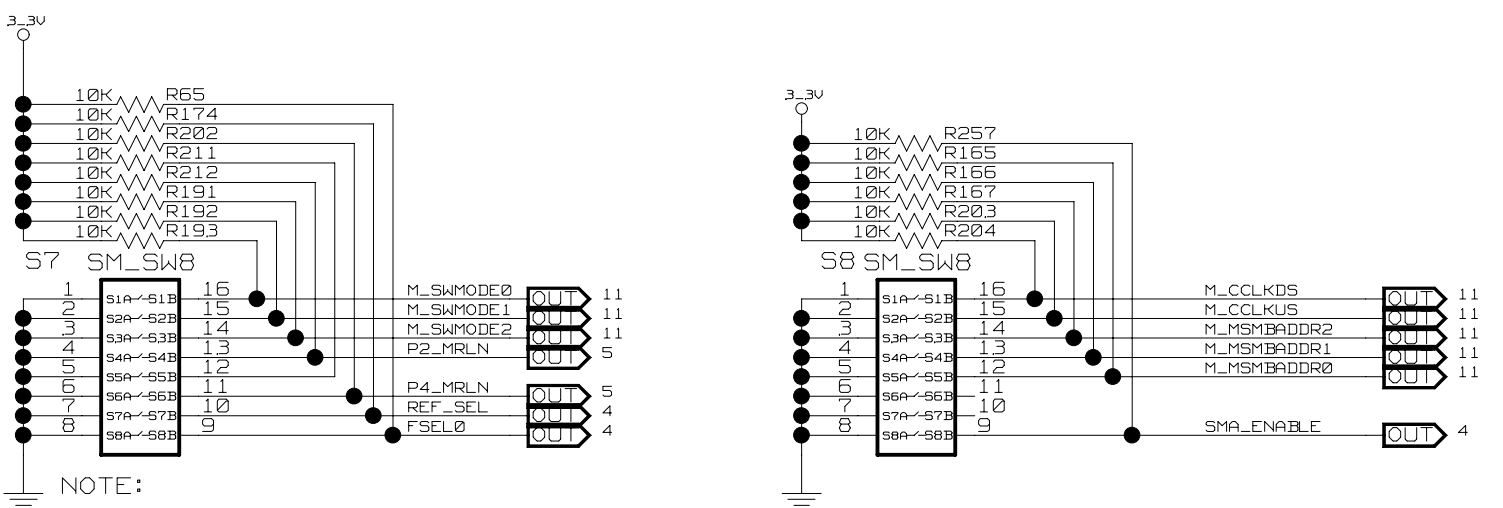

NOTE:
BOTH BIT7 AND BIT8 DEFAULT ARE "ON".



CONFIDENTIAL PROPERTY OF INTEGRATED DEVICE TECHNOLOGY, INC.
6024 SILVER CREEK VALLEY RD. SAN JOSE, CA 95138
COPYRIGHT (C) IDT2008

TITLE 89EPES24T3G2
89HPES24T3G2 - EEPROM, JTAG

| | | | |
|--------------------------|-------------|------------|----------------|
| SIZE | DRAWING NO. | FAB P/N | REV. |
| B | SCH-00146 | 18-657-000 | 1.0 |
| AUTHOR | | CHECKED BY | |
| K Leung / T Tran | | D Huang | |
| Thu Jan 17 16:47:02 2008 | | | SHEET 11 OF 12 |

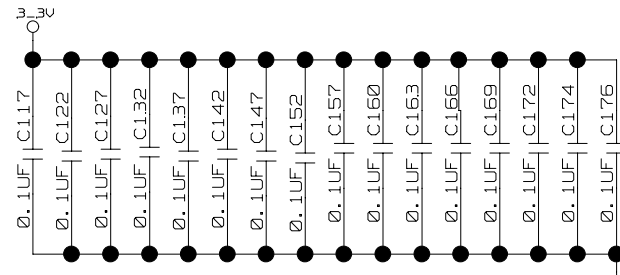
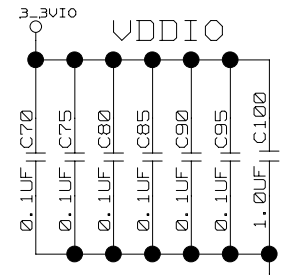
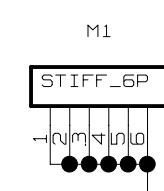
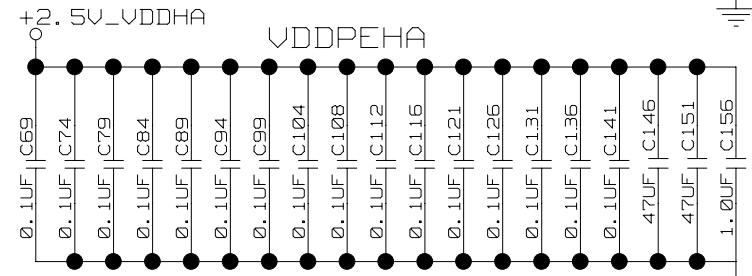
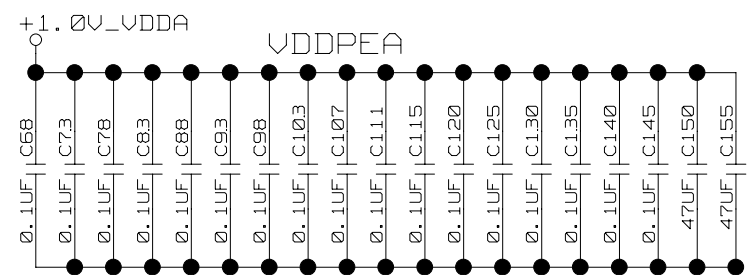
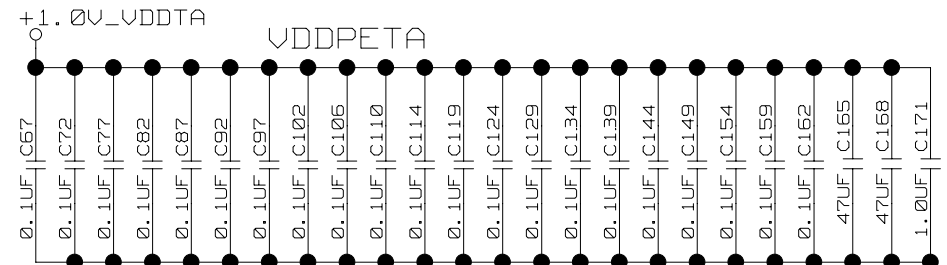
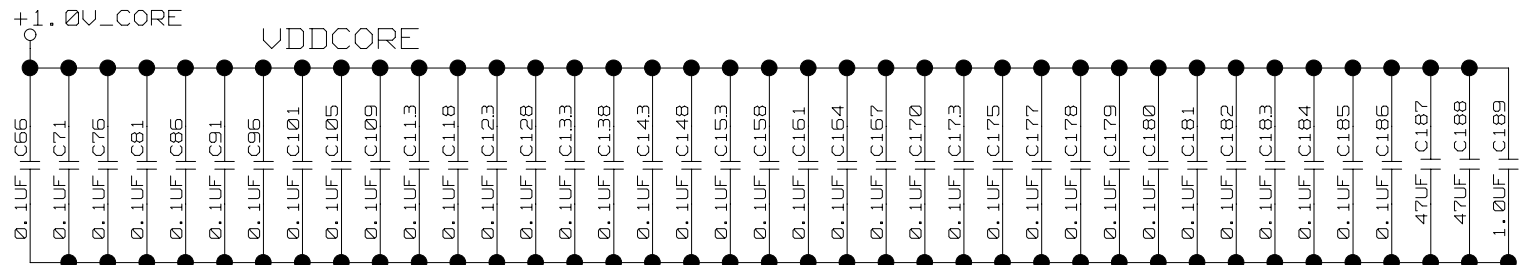
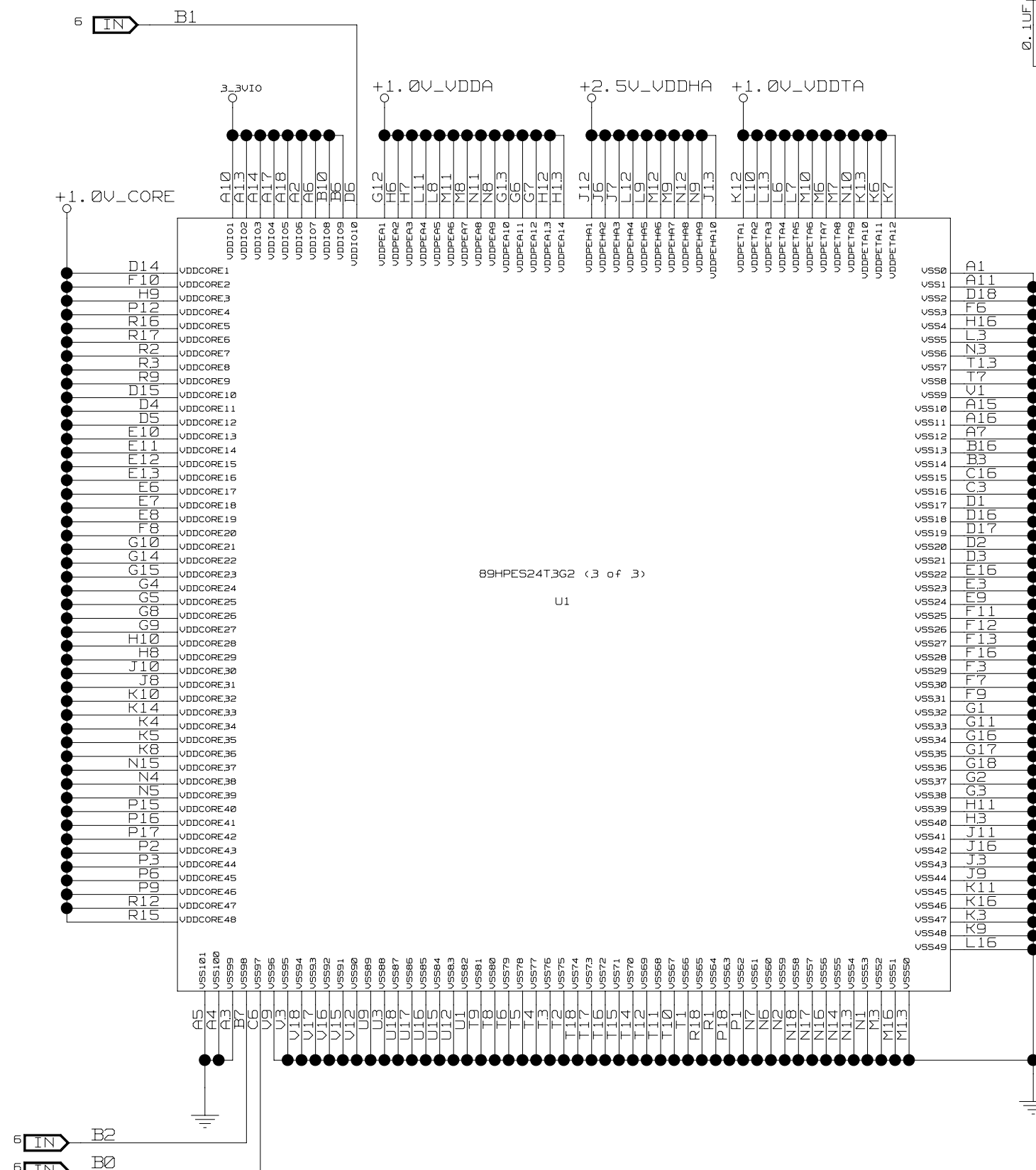

TITLE 89EBPES24T3G2

89HPES24T3G2 - POWER

| | | | |
|--------------------------|-------------|------------|----------------|
| SIZE | DRAWING NO. | FAB P/N | REV. |
| B | SCH-00146 | 18-657-000 | 1.0 |
| AUTHOR | | CHECKED BY | |
| K Leung / T Tran | | D Huang | |
| Thu Jan 17 16:47:05 2008 | | | SHEET 12 OF 12 |

CONFIDENTIAL PROPERTY OF INTEGRATED DEVICE TECHNOLOGY, INC.
6024 SILVER CREEK VALLEY RD. SAN JOSE, CA 95138
COPYRIGHT (C) IDT2008

IMPORTANT NOTICE AND DISCLAIMER

RENESAS ELECTRONICS CORPORATION AND ITS SUBSIDIARIES (“RENESAS”) PROVIDES TECHNICAL SPECIFICATIONS AND RELIABILITY DATA (INCLUDING DATASHEETS), DESIGN RESOURCES (INCLUDING REFERENCE DESIGNS), APPLICATION OR OTHER DESIGN ADVICE, WEB TOOLS, SAFETY INFORMATION, AND OTHER RESOURCES “AS IS” AND WITH ALL FAULTS, AND DISCLAIMS ALL WARRANTIES, EXPRESS OR IMPLIED, INCLUDING, WITHOUT LIMITATION, ANY IMPLIED WARRANTIES OF MERCHANTABILITY, FITNESS FOR A PARTICULAR PURPOSE, OR NON-INFRINGEMENT OF THIRD-PARTY INTELLECTUAL PROPERTY RIGHTS.

These resources are intended for developers who are designing with Renesas products. You are solely responsible for (1) selecting the appropriate products for your application, (2) designing, validating, and testing your application, and (3) ensuring your application meets applicable standards, and any other safety, security, or other requirements. These resources are subject to change without notice. Renesas grants you permission to use these resources only to develop an application that uses Renesas products. Other reproduction or use of these resources is strictly prohibited. No license is granted to any other Renesas intellectual property or to any third-party intellectual property. Renesas disclaims responsibility for, and you will fully indemnify Renesas and its representatives against, any claims, damages, costs, losses, or liabilities arising from your use of these resources. Renesas' products are provided only subject to Renesas' Terms and Conditions of Sale or other applicable terms agreed to in writing. No use of any Renesas resources expands or otherwise alters any applicable warranties or warranty disclaimers for these products.

(Disclaimer Rev.1.01)

Corporate Headquarters

TOYOSU FORESIA, 3-2-24 Toyosu,
Koto-ku, Tokyo 135-0061, Japan
www.renesas.com

Trademarks

Renesas and the Renesas logo are trademarks of Renesas Electronics Corporation. All trademarks and registered trademarks are the property of their respective owners.

Contact Information

For further information on a product, technology, the most up-to-date version of a document, or your nearest sales office, please visit www.renesas.com/contact-us/.