

RRH62000

This document provides guidelines for integrating the RRH62000 into a customer's design, such as HVACs, personal monitors, smoke detectors, or air purifiers, etc. These guidelines will help users obtain the best performance of the RRH62000.



Contents

1. The RRH62000.....	2
2. Package Outline Drawing.....	2
3. Adhesives.....	2
4. Housing Materials.....	3
5. Orientation of the Module	3
6. Mounting Examples.....	3
7. Revision History	4

1. The RRH62000

Figure 1 shows the RRH62000 module. Ensure to point the front side of the device with the inlet and outlet towards the ambient air. The backside contains the 6-pin connector (ACES 51468-0064N-001)¹ which is compatible with the JST GHR series.

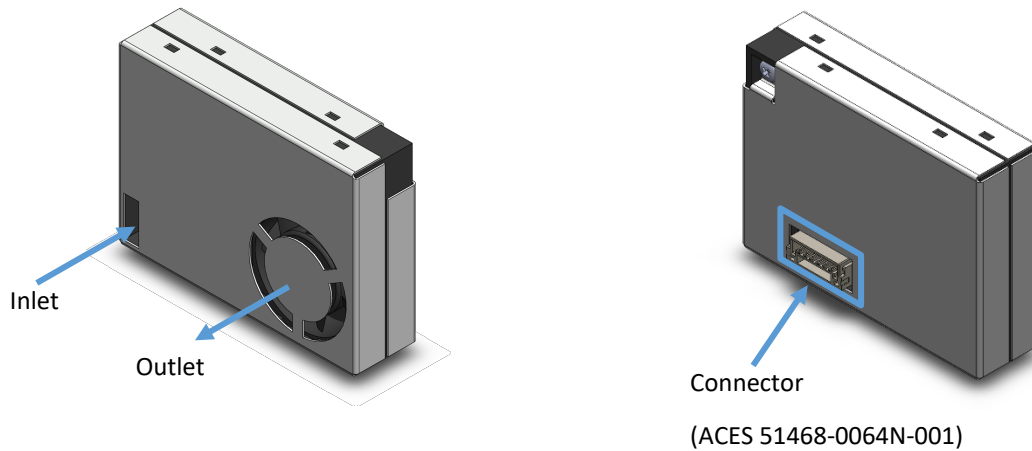

Figure 1. 3D View of the RRH62000

2. Package Outline Drawing

Figure 2 shows the Package Outline Drawing (POD) for the RRH62000. The most relevant dimensions for a successful case or mount design are shown in the figure. For cut-outs, it is best to use the center points and design the cut-out symmetrical around them. All dimensions are in millimetres (mm).

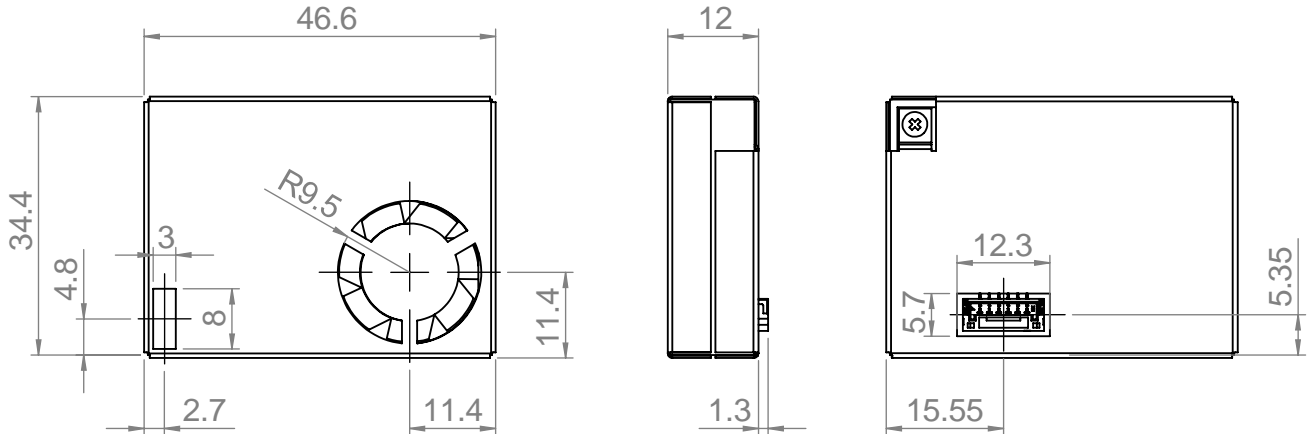

Figure 2. Package Outline Drawing (All dimensions in mm)

3. Adhesives

The RRH62000 consists of a gas sensor that is sensitive to total volatile organic compounds (TVOC). The use of an outgassing adhesive will affect the readings, and also may block the surface of the sensitive element. Renesas has tested various adhesives, and therefore, can recommend low outgassing glues. For more information, please contact your local Renesas Support or submit an [online support ticket](#).

¹ The release batch may be supplied with a different connector (JCTC 50801W00-6P-S-HF) which is compatible with the JST SUH series. Each module will be supplied with an adapter cable for the new connector.

4. Housing Materials

Similar to the adhesives, the housing materials should not outgas. Renesas recommends durable materials without plasticizers, softeners, or large porosity materials. The material must be fully cured, and acrylic type materials should be used instead of silicone type materials. Avoid using additives in the raw materials, such as flame retardants, which may outgas when exposed to high temperatures.

Avoid the use of high porosity materials (e.g., open-pore foams), mould release agents, oils and greases, and silicone-containing potting compounds inside the housing near the gas sensor.

5. Orientation of the Module

Figure 3 shows the recommended installation orientations. This ensures that the heavier particles are properly expelled from the air duct. Orienting the inlet and outlet downwards forces the RRH62000 to suck in particles against gravity, resulting in under-reporting of the heavier particles. Also, when using the sensor in an air duct, make sure that the passing air does not carry the expelled particles back to the inlet.

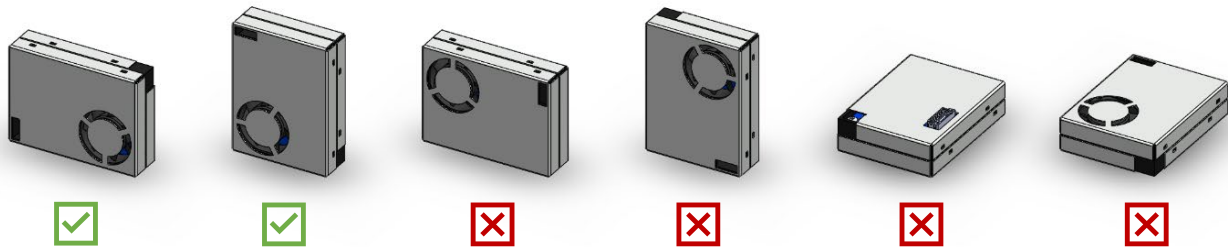

Figure 3. Recommended Orientation for Design-In

6. Mounting Examples

Figure 4 shows the recommendation for mounting the RRH62000 in an air duct. To mount the sensor at the top/bottom, please consider an adapter that maintains the recommended sensor orientation and redirects the airflow towards the sensor.

The mounts displayed in the figure are available for download as a 3D STEP file on the Renesas website. Please remember that these are examples and have not been fully tested.

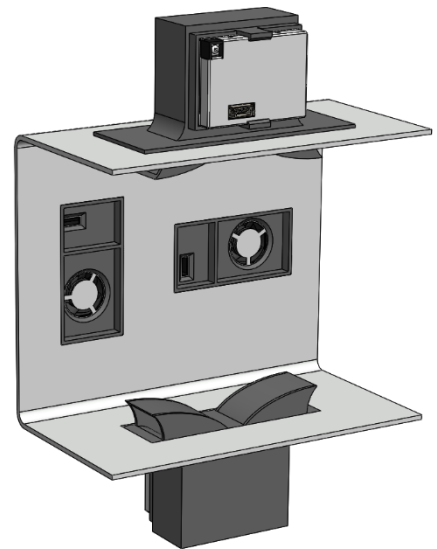

Figure 4. Design-In Examples for Air Duct

7. Revision History

Revision	Date	Description
1.00	May 31, 2024	Initial release.

IMPORTANT NOTICE AND DISCLAIMER

RENESAS ELECTRONICS CORPORATION AND ITS SUBSIDIARIES (“RENESAS”) PROVIDES TECHNICAL SPECIFICATIONS AND RELIABILITY DATA (INCLUDING DATASHEETS), DESIGN RESOURCES (INCLUDING REFERENCE DESIGNS), APPLICATION OR OTHER DESIGN ADVICE, WEB TOOLS, SAFETY INFORMATION, AND OTHER RESOURCES “AS IS” AND WITH ALL FAULTS, AND DISCLAIMS ALL WARRANTIES, EXPRESS OR IMPLIED, INCLUDING, WITHOUT LIMITATION, ANY IMPLIED WARRANTIES OF MERCHANTABILITY, FITNESS FOR A PARTICULAR PURPOSE, OR NON-INFRINGEMENT OF THIRD-PARTY INTELLECTUAL PROPERTY RIGHTS.

These resources are intended for developers who are designing with Renesas products. You are solely responsible for (1) selecting the appropriate products for your application, (2) designing, validating, and testing your application, and (3) ensuring your application meets applicable standards, and any other safety, security, or other requirements. These resources are subject to change without notice. Renesas grants you permission to use these resources only to develop an application that uses Renesas products. Other reproduction or use of these resources is strictly prohibited. No license is granted to any other Renesas intellectual property or to any third-party intellectual property. Renesas disclaims responsibility for, and you will fully indemnify Renesas and its representatives against, any claims, damages, costs, losses, or liabilities arising from your use of these resources. Renesas' products are provided only subject to Renesas' Terms and Conditions of Sale or other applicable terms agreed to in writing. No use of any Renesas resources expands or otherwise alters any applicable warranties or warranty disclaimers for these products.

(Disclaimer Rev.1.01 Jan 2024)

Corporate Headquarters

TOYOSU FORESIA, 3-2-24 Toyosu,
Koto-ku, Tokyo 135-0061, Japan
www.renesas.com

Trademarks

Renesas and the Renesas logo are trademarks of Renesas Electronics Corporation. All trademarks and registered trademarks are the property of their respective owners.

Contact Information

For further information on a product, technology, the most up-to-date version of a document, or your nearest sales office, please visit www.renesas.com/contact-us/.