

---

**P9415 Wireless Power  
MTP Programming Guide**

---

**Contents**

1. Introduction.....	2
2. MTP Programming Procedure .....	3
3. MTP Programming Flow Chart .....	5
4. MTP CRC Verification Flow Chart .....	6
5. Power Cycle in Between MTP Programming and CRC Checking.....	7
6. MTP Downloader Code.....	7
6.1 MTP downloader Code for Powering P9415 at Vout .....	7
6.2 MTP Downloader Code for Powering P9415 at Vrect.....	9
7. Revision History .....	12

**Figures**

Figure 1. P9415 MTP Downloader and MTP Programming Overview.....	2
Figure 2. MTP Programming Flow Chart.....	5
Figure 3. MTP CRC Verification Flow Chart.....	6
Figure 4. Capture of Power Cycle In Between MTP Programming and CRC Checking .....	7

## 1. Introduction

In multi-time programmable (MTP) programming mode, the P9415 runs a temporary MTP downloader program that is loaded and executed in the RAM. The application processor (AP) communicates with the downloader to send the data that needs to be programmed by MTP. The MTP downloader will perform the programming and verify the data being programmed. This approach ensures maximum speed, safety, and is the easiest implementation by the customer.

The  $\mu\text{C}$  is halted before loading the MTP downloader in the RAM. Any program (or process) running up to this point is interrupted and abandoned. The  $\mu\text{C}$  is reset (or power is removed) after MTP programming is completed, followed with fresh start. If the programming was successful, the newly programmed firmware (FW) starts execution. If the programming failed, the  $\mu\text{C}$  enters exception state. Any partially programmed sector in the MTP retains its data. The MTP programming procedure can be restarted multiple times until completed successfully. The  $\mu\text{C}$  does not need to be reset to restart the programming process – just run the MTP programming process from the beginning until completed with “pass” result. If the power is removed during programming, the process can be restarted. The MTP downloader programs only the bits that need to be programmed and it skips memory locations already containing the correct data.

In order to program the IDTP9415 Receiver, DC power should be supplied at VRect or Vout on the P9415 Receiver. Different MTP downloaders are used with each supply location. AC power is provided by a Wireless Power Transmitter (WPTX) that needs periodic communication, which the programming process does not support. The WPTX will remove the power after protocol timeout thus leaving the MTP only partially programmed. Following AC resubmission is not possible because the P9415 is left with partially programmed MTP memory and non-functioning FW needed to complete a power transfer contract.

The MTP programming hardware charge pump is connected to Vout on the P9415. When the power is applied to Vout, the circuit is initially powered through the LDO body diode and after the downloader starts execution the LDO is turned ON, connecting Vrect to Vout.

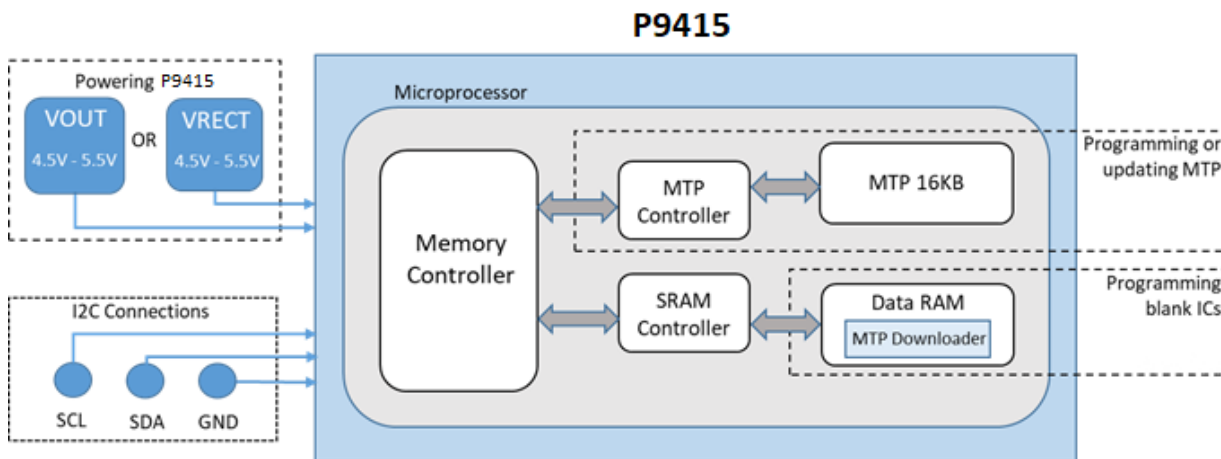

Figure 1. P9415 MTP Downloader and MTP Programming Overview

## 2. MTP Programming Procedure

- 1) Power up the P9415 Rx with 5V  $\pm$ 10% at Vout or Vrect.
- 2) Open the IDTP9415 GUI and establish I2C connection using device address 0x3B.
- 3) Write address **0x3000** = [0x5A] to unlock system registers.
- 4) Set timing and clock.
  - a) Configure clocks and timing.
    - i) Write **0x00** to address **0x3004** to set HS clock.
    - ii) Write **0x09** to address **0x3008** to set AHB clock.
    - iii) Write **0x05** to address **0x300C** to configure 1 $\mu$ s pulse.
    - iv) Write **0x1D** to address **0x300D** to configure 500ns pulse.
  - b) Pause the processor and enable MTP access via I2C.
    - i) Write **0x11** to address **0x3040**.  
Wait 10ms
- 5) Write address **0x3040** = [0x10] to halt the  $\mu$ C.  
Wait 10ms
- 6) Load the MTP downloader program in the RAM at address **0x0800**. The program is in a text format of a 'C' code constant byte array MTPDownloader9415 (size of byte array depends on whether VRect or Vout bootloader is being used).
- 7) Write address **0x0400** = [0x00] to initialize the programming structure in the RAM.
- 8) Write address **0x3048** = [0xD0] to remap RAM to program memory space.
- 9) Write address **0x3040** = [0x80] and then wait 100mS to reset the  $\mu$ C and run the MTP downloader program.  
*NOTE: The PC packet will not be acknowledged.*  
Wait 100ms
- 10) Program the FW in the MTP. The FW is provided as a "hex" or "bin" file and will be loaded in 128-byte sections. The starting address for programming is 0x0000.
  - a) Address **0x0400** in RAM must be loaded for every individual section of code before programming begins. The structure declaration is provided below and the memory is in Little Endian format:
 

```
//typedef struct { // the structure is mapped to RAM address 0x0400
//    u16 Status;
//    u16 StartAddr;
//    u16 CodeLength;
//    u16 DataChksum;
//    u8 DataBuf[128];
//} P9415PgmStrType;
```

    - i) Load Status = 0x0000;
    - ii) Load StartAddress = address\_of\_the\_current\_section of FW;
    - iii) Load CodeLength = section\_length\_in\_bytes; // usually 128.
    - iv) Load DataChksum = sum of StartAddress, CodeLength, and data bytes.
    - v) Load DataBuff with data from the FW source file.
  - b) Write **0x0400** = [0x01] to start programming cycle. The downloader executes the MTP programming FW and checks the integrity of the data. The MTP memory is verified byte by byte against the structure in the RAM.
  - c) At completion of the programming cycle, the MTP downloader clears BIT0 at address **0x0401** and loads Status Code. The Status Codes are:
    - 0x02 – "OK". Programming was successful.
    - 0x04 – "MTP Write Error". Read back value does not match value in the RAM.
    - 0x08 – "Check Sum Error". The programming structure integrity is corrupt.
    - Codes not mentioned above are reserved.
  - d) The Application Processor reads the code and proceeds to the next logical step.
- 11) After programming is completed, power cycle the IDTP9415.  
**[NOTE: The power on the device is required to be turned off completely and back on. Please refer to section 5 "MTP Programming and CRC Checking" for details.]**

- 12) Write address **0x3000** = **[0x5A]** to unlock system registers.
- 13) Set timing and clock.
  - a) Configure clocks and timing.
    - i) Write **0x00** to address **0x3004** to set HS clock.
    - ii) Write **0x09** to address **0x3008** to set AHB clock.
    - iii) Write **0x05** to address **0x300C** to configure 1µs pulse.
    - iv) Write **0x1D** to address **0x300D** to configure 500ns pulse.
    - v) Write **0x00** to address **0x304C** to remove MTP write protection.
    - vi) Write **0x00** to address **0x304D** to reset M0.
  - b) Pause the processor and enable MTP access via I2C.
    - i) Write **0x11** to address **0x3040**.  
Wait 10ms
- 14) Write address **0x3040** = **[0x10]** to halt the µC.  
Wait 10ms
- 15) Load the MTP downloader program in the RAM at address **0x0800**. The program is in a text format of a 'C' code constant byte array MTPDownloader9415 (size of byte array depends on whether VRect or Vout bootloader is being used).
- 16) Write address **0x0400** = **[0x00]** to initialize the programming structure in the RAM.
- 17) Write address **0x3048** = **[0xD0]** to remap RAM to program memory space.
- 18) Write address **0x3040** = **[0x80]** and then wait 100ms to reset the µC and run the MTP downloader program.  
*NOTE: The I<sup>2</sup>C packet will not be acknowledged.*  
Wait 100ms
- 19) Configure MTP CRC Check Utility:
  - a) Load 16-bit MTP start address to **0x402**. Note: 0x402 (low byte), 0x403 (high byte) Start address will be set to 0x0000 to run the verifier from the beginning of the MTP.
  - b) Load 16-bit MTP data size 0x6000 to **0x404**. Note: **0x404** (low byte), **0x405** (high byte) MTP data size. The data size is 24K bytes.
  - c) Write the 16-bit CRC into address **0x406**. Note: 0x406 (low byte), 0x407 (high byte) Checksum value is provided as part of release package for each FW. Calculation is done using following steps: The first byte is the data in MTP start address and the last byte is the data in MTP start\_address + data\_size -1.
  - d) Write **0x0400** = **[0x11]** to start MTP data CRC-16 check.
  - e) Wait 20ms.
  - f) The MTP verifier clears BIT0 at address **0x400** when the program finishes, and loads the Status Code to **0x401**.

The Status Codes are:

- 0x01 –CRC Busy
- 0x02 –CRC OK
- 0x08 –CRC ERROR (go to step 21)

### **20) After programming is completed, power cycle IDTP9415 chip.**

- 21) In case of CRC ERROR, repeat the process from steps 1-20 for 2 retries.

### 3. MTP Programming Flow Chart

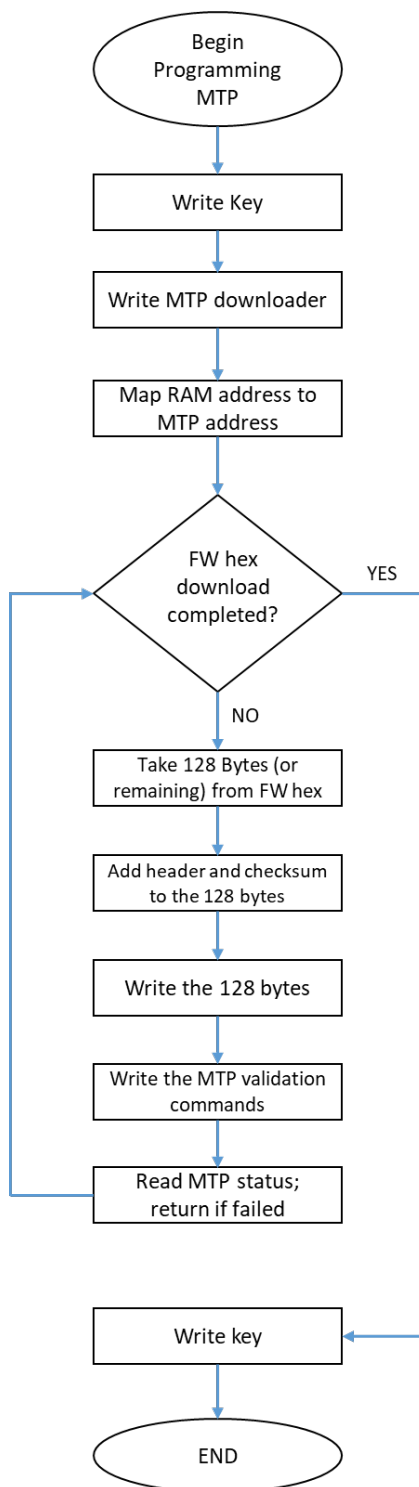

Figure 2. MTP Programming Flow Chart

## 4. MTP CRC Verification Flow Chart

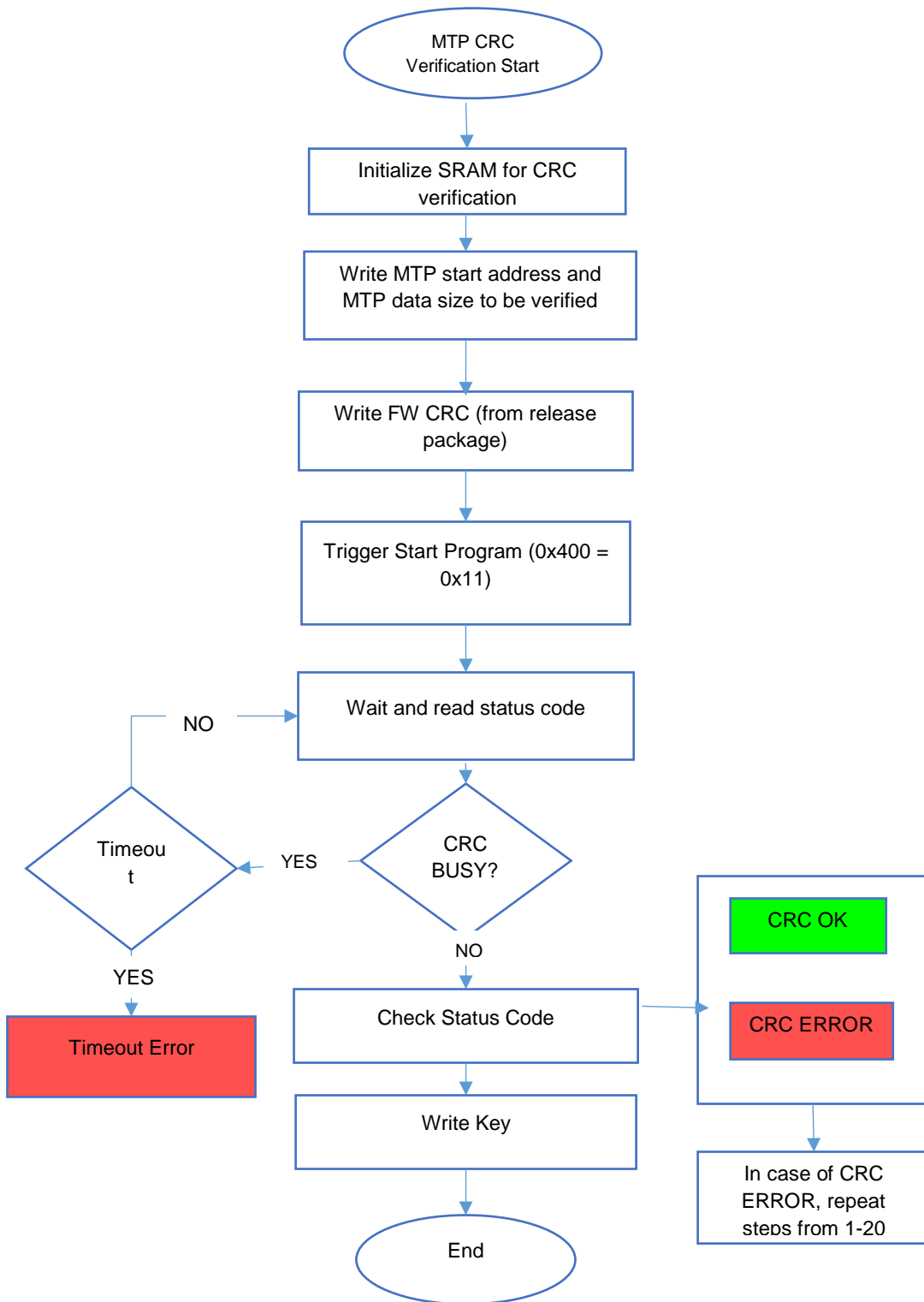

Figure 3. MTP CRC Verification Flow Chart

## 5. Power Cycle in Between MTP Programming and CRC Checking

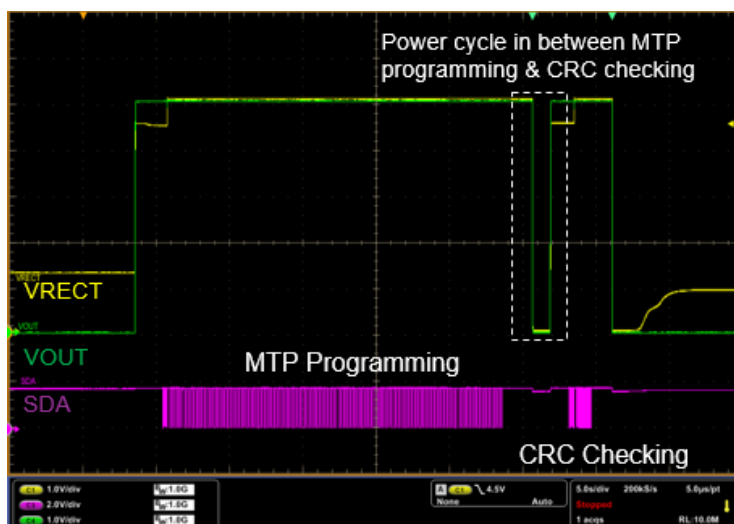

Figure 4. Capture of Power Cycle In Between MTP Programming and CRC Checking

## 6. MTP Downloader Code

### 6.1 MTP downloader Code for Powering P9415 at Vout

//this byte array needs to be loaded at RAM address 0x0800. This is the MTP downloader and it also verifies CRC.

// use this array with power supply connected to Vout

//Do not modify this code

```
static byte[] MTPDownloader9415 = {
```

```
0x00, 0x02, 0x00, 0x20, 0x99, 0x00, 0x00, 0x00, 0x9D, 0x00, 0x00, 0x00, 0x9F, 0x00, 0x00, 0x00,
0x00, 0xF0, 0x02, 0xF8, 0x00, 0xF0, 0x30, 0xF8, 0x0C, 0xA0, 0x30, 0xC8, 0x08, 0x38, 0x24, 0x18,
0x2D, 0x18, 0xA2, 0x46, 0x67, 0x1E, 0xAB, 0x46, 0x54, 0x46, 0x5D, 0x46, 0xAC, 0x42, 0x01, 0xD1,
0x00, 0xF0, 0x22, 0xF8, 0x7E, 0x46, 0x0F, 0x3E, 0x0F, 0xCC, 0xB6, 0x46, 0x01, 0x26, 0x33, 0x42,
0x00, 0xD0, 0xFB, 0x1A, 0xA2, 0x46, 0xAB, 0x46, 0x33, 0x43, 0x18, 0x47, 0xA8, 0x06, 0x00, 0x00,
0xB8, 0x06, 0x00, 0x00, 0x00, 0x23, 0x00, 0x24, 0x00, 0x25, 0x00, 0x26, 0x10, 0x3A, 0x01, 0xD3,
0x78, 0xC1, 0xFB, 0xD8, 0x52, 0x07, 0x00, 0xD3, 0x30, 0xC1, 0x00, 0xD5, 0x0B, 0x60, 0x70, 0x47,
0x1F, 0xB5, 0x1F, 0xBD, 0x10, 0xB5, 0x10, 0xBD, 0x00, 0xF0, 0x09, 0xFB, 0x11, 0x46, 0xFF, 0xF7,
0xF7, 0xFF, 0x00, 0xF0, 0x45, 0xFA, 0x00, 0xF0, 0x21, 0xFB, 0x03, 0xB4, 0xFF, 0xF7, 0xF2, 0xFF,
0x03, 0xBC, 0x00, 0xF0, 0x27, 0xFB, 0x00, 0x00, 0x05, 0x48, 0x00, 0x47, 0xFE, 0xE7, 0xFE, 0xE7,
0xFE, 0xE7, 0x00, 0x00, 0x03, 0x48, 0x04, 0x49, 0x02, 0x4A, 0x04, 0x4B, 0x70, 0x47, 0x00, 0x00,
0x11, 0x00, 0x00, 0x00, 0x60, 0x00, 0x00, 0x20, 0x60, 0x01, 0x00, 0x20, 0x60, 0x00, 0x00, 0x20,
0xFE, 0xB5, 0x04, 0x46, 0x00, 0x20, 0x02, 0x90, 0x10, 0x20, 0x40, 0x00, 0x28, 0x64, 0xD0,
0x01, 0x20, 0xFA, 0x4E, 0x30, 0x80, 0x80, 0x1E, 0x30, 0x81, 0x01, 0x46, 0xF8, 0x4E, 0x31, 0x83,
0x08, 0x0C, 0x70, 0x83, 0x00, 0x22, 0x44, 0xE0, 0xF6, 0x48, 0x40, 0x88, 0x80, 0x18, 0x83, 0xB2,
0x01, 0x93, 0xD8, 0x13, 0x00, 0x28, 0x03, 0xD1, 0x01, 0x20, 0xC0, 0x03, 0x18, 0x43, 0x01, 0x90,
0xEF, 0x48, 0xC2, 0x81, 0x03, 0x80, 0xEE, 0x4E, 0x01, 0x98, 0x70, 0x80, 0x01, 0x98, 0x05, 0x78,
0xEA, 0x48, 0x85, 0x80, 0x30, 0x46, 0x85, 0x80, 0x30, 0x20, 0x40, 0x10, 0x28, 0x07, 0xD1,
0x00, 0xBF, 0xE6, 0x48, 0x00, 0x88, 0x40, 0x06, 0xC0, 0x0F, 0x00, 0x28, 0xF9, 0xD1, 0x1E, 0xE0,
0x00, 0x20, 0x00, 0x90, 0x18, 0xE0, 0xC8, 0x0F, 0x07, 0x27, 0x00, 0x9E, 0xBE, 0x1B, 0x2F, 0x46,
0x37, 0x41, 0xFE, 0x07, 0xF6, 0x0F, 0x70, 0x40, 0x00, 0x28, 0x01, 0xD0, 0xDE, 0x48, 0x00, 0xE0,
0x00, 0x20, 0x4E, 0x00, 0x70, 0x40, 0x01, 0x46, 0xD9, 0x4E, 0x31, 0x83, 0x08, 0x0C, 0x70, 0x83,
0x00, 0x98, 0x40, 0x1C, 0xC0, 0xB2, 0x00, 0x90, 0x00, 0x98, 0x07, 0x28, 0xE3, 0xDD, 0x50, 0x1C,
0x82, 0xB2, 0xD4, 0x48, 0x80, 0x88, 0x90, 0x42, 0xB6, 0xDC, 0x30, 0x20, 0x20, 0x40, 0x10, 0x28,
0x13, 0xD1, 0xCE, 0x48, 0x00, 0x89, 0xCE, 0x4E, 0x70, 0x82, 0xCC, 0x48, 0x00, 0x89, 0xCD, 0x4E,
0xF6, 0x88, 0xB0, 0x42, 0x02, 0xD1, 0x00, 0x20, 0x02, 0x90, 0x2F, 0xE0, 0x01, 0x20, 0x02, 0x90,
0xC6, 0x48, 0x00, 0x89, 0xC7, 0x4E, 0xF0, 0x80, 0x28, 0xE0, 0x88, 0xB2, 0xC5, 0x4E, 0xF6, 0x88,
```

0xB0, 0x42, 0x01, 0xD1, 0x01, 0x20, 0x00, 0xE0, 0x00, 0x20, 0x0E, 0x02, 0x36, 0x0E, 0xC1, 0x4F,  
 0x3F, 0x7A, 0xBE, 0x42, 0x01, 0xD1, 0x01, 0x26, 0x00, 0xE0, 0x00, 0x26, 0x30, 0x40, 0x0E, 0x0E,  
 0xBC, 0x4F, 0x7F, 0x7A, 0xBE, 0x42, 0x01, 0xD1, 0x01, 0x26, 0x00, 0xE0, 0x00, 0x26, 0x30, 0x40,  
 0x00, 0x28, 0x02, 0xD0, 0x00, 0x20, 0x02, 0x90, 0x08, 0xE0, 0x01, 0x20, 0x02, 0x90, 0xB5, 0x4E,  
 0xF1, 0x80, 0x08, 0x02, 0x00, 0x0E, 0x30, 0x72, 0x08, 0x0E, 0x70, 0x72, 0x02, 0x98, 0xFE, 0xBD,  
 0x10, 0xB5, 0x02, 0x46, 0xAE, 0x4B, 0x1B, 0x8A, 0x04, 0x24, 0x23, 0x43, 0xAC, 0x4C, 0x23, 0x82,  
 0x00, 0x23, 0xAE, 0x4C, 0xA3, 0x81, 0x93, 0x00, 0x19, 0x60, 0xAD, 0x4B, 0x1B, 0x88, 0xA4, 0x14,  
 0x23, 0x40, 0x18, 0x46, 0xA6, 0x4B, 0x1B, 0x8A, 0x04, 0x24, 0xA3, 0x43, 0xA4, 0x4C, 0x23, 0x82,  
 0xA8, 0x4B, 0xA6, 0x4C, 0xA3, 0x81, 0x10, 0xBD, 0x10, 0xB5, 0x02, 0x46, 0xA0, 0x4B, 0x1B, 0x8A,  
 0x02, 0x24, 0x23, 0x43, 0x9E, 0x4C, 0x23, 0x82, 0x00, 0x23, 0xA0, 0x4C, 0xA3, 0x81, 0x11, 0x70,  
 0x9F, 0x4B, 0x1B, 0x88, 0xA4, 0x14, 0x23, 0x40, 0x18, 0x46, 0x99, 0x4B, 0x1B, 0x8A, 0x02, 0x24,  
 0xA3, 0x43, 0x97, 0x4C, 0x23, 0x82, 0x9B, 0x4B, 0x98, 0x4C, 0xA3, 0x81, 0x10, 0xBD, 0xF1, 0xB5,  
 0x88, 0xB0, 0x08, 0x9D, 0x00, 0x20, 0x00, 0x90, 0x91, 0x48, 0x00, 0x8A, 0x08, 0x21, 0x88, 0x43,  
 0x8F, 0x49, 0x08, 0x82, 0x8F, 0x48, 0x00, 0x88, 0x00, 0x07, 0x00, 0x0F, 0x03, 0x90, 0x8D, 0x48,  
 0x40, 0x88, 0x02, 0x90, 0x8B, 0x48, 0x80, 0x88, 0x01, 0x90, 0x01, 0x99, 0x02, 0x98, 0x40, 0x18,  
 0x40, 0x1E, 0x80, 0xB2, 0x05, 0x90, 0x05, 0x98, 0xC0, 0x13, 0x00, 0x28, 0x04, 0xD1, 0x01, 0x21,  
 0xC9, 0x03, 0x05, 0x98, 0x08, 0x43, 0x05, 0x90, 0x02, 0x98, 0x07, 0x90, 0x01, 0x99, 0x07, 0x98,  
 0x40, 0x18, 0x80, 0xB2, 0x07, 0x90, 0x00, 0x27, 0x08, 0xE0, 0x7E, 0x48, 0x08, 0x30, 0xC1, 0x5D,  
 0x07, 0x98, 0x08, 0x18, 0x80, 0xB2, 0x07, 0x90, 0x78, 0x1C, 0x87, 0xB2, 0x01, 0x98, 0x87, 0x42,  
 0xF3, 0xDB, 0x77, 0x49, 0x07, 0x98, 0x48, 0x82, 0x76, 0x48, 0xC1, 0x88, 0x07, 0x98, 0x81, 0x42,  
 0x73, 0xD1, 0x03, 0x98, 0x01, 0x28, 0x01, 0xD1, 0x00, 0x20, 0x0C, 0xE0, 0x03, 0x98, 0x03, 0x28,  
 0x01, 0xD1, 0x04, 0x20, 0x07, 0xE0, 0x03, 0x98, 0x05, 0x28, 0x01, 0xD1, 0x24, 0x20, 0x02, 0xE0,  
 0x6F, 0x48, 0x20, 0x30, 0x00, 0x89, 0x6E, 0x49, 0x20, 0x31, 0x08, 0x81, 0x00, 0x27, 0xBE, 0xE0,  
 0x02, 0x98, 0xC0, 0x19, 0x80, 0xB2, 0x06, 0x90, 0x30, 0x0A, 0x66, 0x49, 0x08, 0x31, 0xC9, 0x5D,  
 0x09, 0x06, 0x08, 0x43, 0x06, 0x46, 0x06, 0x9C, 0x61, 0x48, 0xC7, 0x81, 0x60, 0x49, 0x06, 0x98,  
 0x08, 0x80, 0x30, 0x0C, 0xC8, 0x80, 0x8E, 0x80, 0x06, 0x98, 0xC0, 0x13, 0x00, 0x28, 0x03, 0xD1,  
 0x89, 0x13, 0x06, 0x98, 0x08, 0x43, 0x04, 0x46, 0x04, 0x98, 0x00, 0x0A, 0x21, 0x78, 0x09, 0x06,  
 0x08, 0x43, 0x04, 0x90, 0x56, 0x48, 0x44, 0x80, 0x04, 0x98, 0x00, 0x0C, 0x54, 0x49, 0x48, 0x81,  
 0x04, 0x98, 0x08, 0x81, 0x03, 0x98, 0x01, 0x28, 0x02, 0xD0, 0x03, 0x98, 0x03, 0x28, 0x16, 0xD1,  
 0x04, 0x98, 0x00, 0x0E, 0x31, 0x0E, 0x88, 0x42, 0x0D, 0xD0, 0x31, 0x0E, 0x20, 0x46, 0xFF, 0xF7,  
 0x53, 0xFF, 0x00, 0x28, 0x08, 0xD1, 0x20, 0x78, 0x04, 0x90, 0x31, 0x0E, 0x04, 0x98, 0x81, 0x42,  
 0x79, 0xD0, 0x68, 0x1C, 0x85, 0xB2, 0x76, 0xE0, 0x68, 0x1C, 0x85, 0xB2, 0x73, 0xE0, 0x03, 0x98,  
 0x05, 0x28, 0x70, 0xD1, 0xA0, 0x07, 0x80, 0x0F, 0x00, 0x28, 0x07, 0xD1, 0x01, 0x20, 0x00, 0x90,  
 0x3F, 0x48, 0x00, 0x8A, 0x08, 0x21, 0x08, 0x43, 0x3D, 0x49, 0x08, 0x82, 0x42, 0x49, 0x05, 0x98,  
 0x08, 0x40, 0xA0, 0x42, 0x02, 0xD1, 0x01, 0x20, 0x01, 0xE0, 0x65, 0xE0, 0x00, 0x20, 0x05, 0x99,  
 0x89, 0x07, 0x89, 0x0F, 0x03, 0x29, 0x01, 0xD0, 0x01, 0x21, 0x00, 0xE0, 0x00, 0x21, 0x08, 0x40,  
 0x00, 0x28, 0x07, 0xD0, 0x00, 0x20, 0x00, 0x90, 0x31, 0x48, 0x00, 0x8A, 0x08, 0x21, 0x88, 0x43,  
 0x2F, 0x49, 0x08, 0x82, 0x00, 0x98, 0x00, 0x28, 0x20, 0xD1, 0x31, 0x48, 0x20, 0x30, 0x00, 0x89,  
 0x20, 0x21, 0x88, 0x43, 0x2E, 0x49, 0x20, 0x31, 0x08, 0x81, 0x08, 0x46, 0x00, 0x89, 0x04, 0x21,  
 0x08, 0x43, 0x2B, 0x49, 0x20, 0x31, 0x08, 0x81, 0x31, 0x0E, 0x20, 0x46, 0xFF, 0xF7, 0x04, 0xFF,  
 0x00, 0x28, 0x08, 0xD1, 0x20, 0x78, 0x04, 0x90, 0x31, 0x0E, 0x04, 0x98, 0x81, 0x42, 0x2A, 0xD0,  
 0x68, 0x1C, 0x85, 0xB2, 0x27, 0xE0, 0x68, 0x1C, 0x85, 0xB2, 0x24, 0xE0, 0xA0, 0x07, 0x80, 0x0F,  
 0x03, 0x28, 0x20, 0xD1, 0x1E, 0x48, 0x20, 0x30, 0x00, 0x89, 0x20, 0x21, 0x08, 0x43, 0x1C, 0x49,  
 0x20, 0x31, 0x08, 0x81, 0x08, 0x46, 0x00, 0x89, 0x04, 0x21, 0x08, 0x43, 0x18, 0x49, 0x20, 0x31,  
 0x08, 0x81, 0xA0, 0x10, 0x31, 0x46, 0xFF, 0xF7, 0xC3, 0xFE, 0x00, 0x28, 0x09, 0xD1, 0xA0, 0x10,  
 0x80, 0x00, 0x00, 0x68, 0x04, 0x90, 0x04, 0x98, 0xB0, 0x42, 0x04, 0xD0, 0x28, 0x1D, 0x85, 0xB2,  
 0x01, 0xE0, 0x28, 0x1D, 0x85, 0xB2, 0x0A, 0x48, 0x85, 0x81, 0x78, 0x1C, 0x87, 0xB2, 0x01, 0x98,  
 0x87, 0x42, 0x00, 0xDA, 0x3C, 0xE7, 0x06, 0xE0, 0x06, 0x48, 0x80, 0x88, 0x40, 0x19, 0x85, 0xB2,  
 0x01, 0x20, 0xC0, 0x03, 0x05, 0x43, 0x28, 0x46, 0x09, 0xB0, 0xF0, 0xBD, 0x00, 0x70, 0x00, 0x40,  
 0x00, 0x05, 0x00, 0x20, 0x00, 0x04, 0x00, 0x20, 0xB7, 0x1D, 0xC1, 0x04, 0x40, 0x30, 0x00, 0x40,  
 0x00, 0x5C, 0x00, 0x40, 0xFF, 0x1F, 0x00, 0x00, 0xFC, 0xFF, 0x00, 0x00, 0x0C, 0xB5, 0x00, 0x21,  
 0x01, 0x91, 0x10, 0xE0, 0x00, 0x21, 0x00, 0x91, 0x04, 0xE0, 0x69, 0x46, 0x09, 0x88, 0x49, 0x1C,  
 0x8A, 0xB2, 0x00, 0x92, 0x69, 0x46, 0x09, 0x88, 0x02, 0x29, 0xF6, 0xDB, 0x69, 0x46, 0x89, 0x88,  
 0x49, 0x1C, 0x8A, 0xB2, 0x01, 0x92, 0x69, 0x46, 0x89, 0x88, 0x81, 0x42, 0xEA, 0xDB, 0x0C, 0xBD,  
 0x5A, 0x20, 0x53, 0x49, 0x08, 0x80, 0x05, 0x20, 0x88, 0x80, 0x04, 0x20, 0x08, 0x81, 0x51, 0x48,  
 0x88, 0x81, 0x50, 0x20, 0xFF, 0xF7, 0xDA, 0xFF, 0x4F, 0x48, 0x4D, 0x49, 0x88, 0x82, 0x4F, 0x48,  
 0x08, 0x82, 0x18, 0x20, 0x88, 0x83, 0x08, 0x46, 0x00, 0x8B, 0x17, 0x21, 0x49, 0x02, 0x08, 0x43,

```

0x47, 0x49, 0x08, 0x83, 0x08, 0x46, 0x00, 0x8B, 0x2E, 0x21, 0x08, 0x43, 0x44, 0x49, 0x08, 0x83,
0x05, 0x20, 0xFF, 0xF7, 0xC3, 0xFF, 0x42, 0x48, 0x80, 0x8B, 0x01, 0x21, 0x08, 0x43, 0x40, 0x49,
0x88, 0x83, 0x32, 0x20, 0x42, 0x49, 0x08, 0x80, 0x94, 0x20, 0x42, 0x49, 0x08, 0x80, 0x15, 0x20,
0x08, 0x80, 0x08, 0x46, 0x80, 0x8A, 0x60, 0x21, 0x88, 0x43, 0x3E, 0x49, 0x88, 0x82, 0x00, 0x20,
0x3D, 0x49, 0x08, 0x80, 0x3D, 0x49, 0x08, 0x80, 0x48, 0x80, 0x00, 0x24, 0x00, 0x27, 0x01, 0x25,
0x00, 0x26, 0x06, 0xE0, 0x00, 0x20, 0x71, 0x00, 0x39, 0x4A, 0x89, 0x18, 0x08, 0x80, 0x70, 0x1C,
0x86, 0xB2, 0x10, 0x2E, 0xF6, 0xDB, 0x5A, 0xE0, 0x34, 0x48, 0x00, 0x88, 0xC0, 0x07, 0xC0, 0x0F,
0x00, 0x28, 0x54, 0xD0, 0x31, 0x48, 0x00, 0x88, 0xC0, 0xB2, 0x30, 0x49, 0x08, 0x80, 0x5A, 0x20,
0x30, 0x49, 0x08, 0x82, 0x00, 0x20, 0x26, 0x49, 0x60, 0x31, 0x08, 0x80, 0x2B, 0x48, 0x00, 0x88,
0x11, 0x21, 0x08, 0x40, 0x01, 0x28, 0x27, 0xD1, 0x01, 0x25, 0x28, 0x48, 0x00, 0x88, 0xC0, 0xB2,
0x29, 0x02, 0x08, 0x43, 0x25, 0x49, 0x08, 0x80, 0x25, 0x48, 0x00, 0x8A, 0x01, 0x21, 0x08, 0x43,
0x23, 0x49, 0x08, 0x82, 0x00, 0x20, 0xFF, 0xF7, 0x3A, 0xFE, 0x04, 0x46, 0x20, 0x48, 0x00, 0x8A,
0xA8, 0x43, 0x1F, 0x49, 0x08, 0x82, 0x60, 0x04, 0x40, 0x0C, 0xC0, 0x19, 0x87, 0xB2, 0x88, 0x13,
0x20, 0x40, 0x00, 0x28, 0x01, 0xD0, 0x08, 0x20, 0x04, 0xE0, 0x00, 0x2C, 0x01, 0xD0, 0x04, 0x20,
0x00, 0xE0, 0x02, 0x20, 0x05, 0x46, 0x11, 0xE0, 0x01, 0x25, 0x14, 0x48, 0x00, 0x88, 0xC0, 0xB2,
0x29, 0x02, 0x08, 0x43, 0x11, 0x49, 0x08, 0x80, 0x08, 0x88, 0xFF, 0xF7, 0x41, 0xFD, 0x04, 0x46,
0x00, 0x2C, 0x01, 0xD0, 0x08, 0x20, 0x00, 0xE0, 0x02, 0x20, 0x05, 0x46, 0x0B, 0x48, 0x47, 0x80,
0x00, 0x88, 0xFE, 0x21, 0x08, 0x40, 0x29, 0x02, 0x08, 0x43, 0x08, 0x49, 0x08, 0x80, 0xA3, 0xE7,
0x00, 0x30, 0x00, 0x40, 0x01, 0x04, 0x00, 0x00, 0x0A, 0x20, 0x00, 0x00, 0xFF, 0x07, 0x00, 0x00,
0x40, 0x54, 0x00, 0x40, 0x00, 0x58, 0x00, 0x40, 0x40, 0x6C, 0x00, 0x40, 0x00, 0x04, 0x00, 0x20,
0x00, 0x05, 0x00, 0x20, 0x40, 0x5C, 0x00, 0x40, 0x70, 0x47, 0x70, 0x47, 0x70, 0x47, 0x75, 0x46,
0x00, 0xF0, 0x24, 0xF8, 0xAE, 0x46, 0x05, 0x00, 0x69, 0x46, 0x53, 0x46, 0xC0, 0x08, 0xC0, 0x00,
0x85, 0x46, 0x18, 0xB0, 0x20, 0xB5, 0xFF, 0xF7, 0xFD, 0xFC, 0x60, 0xBC, 0x00, 0x27, 0x49, 0x08,
0xB6, 0x46, 0x00, 0x26, 0xC0, 0xC5, 0xC0, 0xC5, 0xC0, 0xC5, 0xC0, 0xC5, 0xC0, 0xC5, 0xC0, 0xC5,
0xC0, 0xC5, 0xC0, 0xC5, 0x40, 0x3D, 0x49, 0x00, 0x8D, 0x46, 0x70, 0x47, 0x10, 0xB5, 0x04, 0x46,
0xC0, 0x46, 0xC0, 0x46, 0x20, 0x46, 0xFF, 0xF7, 0xD8, 0xFC, 0x10, 0xBD, 0x00, 0x48, 0x70, 0x47,
0x00, 0x00, 0x00, 0x20, 0x01, 0x49, 0x18, 0x20, 0xAB, 0xBE, 0xFE, 0xE7, 0x26, 0x00, 0x02, 0x00,
0x70, 0x47, 0x00, 0x00, 0x04, 0x07, 0x00, 0x00, 0x00, 0x00, 0x00, 0x00, 0x20, 0x60, 0x01, 0x00, 0x00,
0x54, 0x00, 0x00, 0x00};

```

## 6.2 MTP Downloader Code for Powering P9415 at Vrect

```

//this byte array needs to be loaded at RAM address 0x0800. This is the MTP downloader and it also
verifies CRC.
// use this array with power supply connected to Vrect
//Do not modify this code
static byte[] MTPDownloader9415 = {
0x00, 0x02, 0x00, 0x20, 0x99, 0x00, 0x00, 0x00, 0x9D, 0x00, 0x00, 0x00, 0x9F, 0x00, 0x00, 0x00,
0x00, 0xF0, 0x02, 0xF8, 0x00, 0xF0, 0x30, 0xF8, 0x0C, 0xA0, 0x30, 0xC8, 0x08, 0x38, 0x24, 0x18,
0x2D, 0x18, 0xA2, 0x46, 0x67, 0x1E, 0xAB, 0x46, 0x54, 0x46, 0x5D, 0x46, 0xAC, 0x42, 0x01, 0xD1,
0x00, 0xF0, 0x22, 0xF8, 0x7E, 0x46, 0x0F, 0x3E, 0x0F, 0xCC, 0xB6, 0x46, 0x01, 0x26, 0x33, 0x42,
0x00, 0xD0, 0xFB, 0x1A, 0xA2, 0x46, 0xAB, 0x46, 0x33, 0x43, 0x18, 0x47, 0x30, 0x06, 0x00, 0x00,
0x40, 0x06, 0x00, 0x00, 0x00, 0x23, 0x00, 0x24, 0x00, 0x25, 0x00, 0x26, 0x10, 0x3A, 0x01, 0xD3,
0x78, 0xC1, 0xFB, 0xD8, 0x52, 0x07, 0x00, 0xD3, 0x30, 0xC1, 0x00, 0xD5, 0x0B, 0x60, 0x70, 0x47,
0x1F, 0xB5, 0x1F, 0xBD, 0x10, 0xB5, 0x10, 0xBD, 0x00, 0xF0, 0xCD, 0xFA, 0x11, 0x46, 0xFF, 0xF7,
0xF7, 0xFF, 0x00, 0xF0, 0x2B, 0xFA, 0x00, 0xF0, 0xE5, 0xFA, 0x03, 0xB4, 0xFF, 0xF7, 0xF2, 0xFF,
0x03, 0xBC, 0x00, 0xF0, 0xEB, 0xFA, 0x00, 0x00, 0x05, 0x48, 0x00, 0x47, 0xFE, 0xE7, 0xFE, 0xE7,
0xFE, 0xE7, 0x00, 0x00, 0x03, 0x48, 0x04, 0x49, 0x02, 0x4A, 0x04, 0x4B, 0x70, 0x47, 0x00, 0x00,
0x11, 0x00, 0x00, 0x00, 0x60, 0x00, 0x00, 0x20, 0x60, 0x01, 0x00, 0x20, 0x60, 0x00, 0x00, 0x20,
0xFE, 0xB5, 0x04, 0x46, 0x00, 0x20, 0x02, 0x90, 0x10, 0x20, 0x20, 0x40, 0x00, 0x28, 0x64, 0xD0,
0x01, 0x20, 0xFA, 0x4E, 0x30, 0x80, 0x80, 0x1E, 0x30, 0x81, 0x01, 0x46, 0xF8, 0x4E, 0x31, 0x83,
0x08, 0x0C, 0x70, 0x83, 0x00, 0x22, 0x44, 0xE0, 0xF6, 0x48, 0x40, 0x88, 0x80, 0x18, 0x83, 0xB2,
0x01, 0x93, 0xD8, 0x13, 0x00, 0x28, 0x03, 0xD1, 0x01, 0x20, 0xC0, 0x03, 0x18, 0x43, 0x01, 0x90,
0xEF, 0x48, 0xC2, 0x81, 0x03, 0x80, 0xEE, 0x4E, 0x01, 0x98, 0x70, 0x80, 0x01, 0x98, 0x05, 0x78,
0xEA, 0x48, 0x85, 0x80, 0x30, 0x46, 0x85, 0x80, 0x30, 0x20, 0x20, 0x40, 0x10, 0x28, 0x07, 0xD1,
0x00, 0xBF, 0xE6, 0x48, 0x00, 0x88, 0x40, 0x06, 0xC0, 0x0F, 0x00, 0x28, 0xF9, 0xD1, 0x1E, 0xE0,
0x00, 0x20, 0x00, 0x90, 0x18, 0xE0, 0xC8, 0x0F, 0x07, 0x27, 0x00, 0x9E, 0xBE, 0x1B, 0x2F, 0x46,

```

0x37, 0x41, 0xFE, 0x07, 0xF6, 0x0F, 0x70, 0x40, 0x00, 0x28, 0x01, 0xD0, 0xDE, 0x48, 0x00, 0xE0,  
0x00, 0x20, 0x4E, 0x00, 0x70, 0x40, 0x01, 0x46, 0xD9, 0x4E, 0x31, 0x83, 0x08, 0x0C, 0x70, 0x83,  
0x00, 0x98, 0x40, 0x1C, 0xC0, 0xB2, 0x00, 0x90, 0x00, 0x98, 0x07, 0x28, 0xE3, 0xDD, 0x50, 0x1C,  
0x82, 0xB2, 0xD4, 0x48, 0x80, 0x88, 0x90, 0x42, 0xB6, 0xDC, 0x30, 0x20, 0x20, 0x40, 0x10, 0x28,  
0x13, 0xD1, 0xCE, 0x48, 0x00, 0x89, 0xCE, 0x4E, 0x70, 0x82, 0xCC, 0x48, 0x00, 0x89, 0xCD, 0x4E,  
0xF6, 0x88, 0xB0, 0x42, 0x02, 0xD1, 0x00, 0x20, 0x02, 0x90, 0x2F, 0xE0, 0x01, 0x20, 0x02, 0x90,  
0xC6, 0x48, 0x00, 0x89, 0xC7, 0x4E, 0xF0, 0x80, 0x28, 0xE0, 0x88, 0xB2, 0xC5, 0x4E, 0xF6, 0x88,  
0xB0, 0x42, 0x01, 0xD1, 0x01, 0x20, 0x00, 0xE0, 0x00, 0x20, 0x0E, 0x02, 0x36, 0x0E, 0xC1, 0x4F,  
0x3F, 0x7A, 0xBE, 0x42, 0x01, 0xD1, 0x01, 0x26, 0x00, 0xE0, 0x00, 0x26, 0x30, 0x40, 0x0E, 0x0E,  
0xBC, 0x4F, 0x7F, 0x7A, 0xBE, 0x42, 0x01, 0xD1, 0x01, 0x26, 0x00, 0xE0, 0x00, 0x26, 0x30, 0x40,  
0x00, 0x28, 0x02, 0xD0, 0x00, 0x20, 0x02, 0x90, 0x08, 0xE0, 0x01, 0x20, 0x02, 0x90, 0xB5, 0x4E,  
0xF1, 0x80, 0x08, 0x02, 0x00, 0x0E, 0x30, 0x72, 0x08, 0x0E, 0x70, 0x72, 0x02, 0x98, 0xFE, 0xBD,  
0x10, 0xB5, 0x02, 0x46, 0xAE, 0x4B, 0x1B, 0x8A, 0x04, 0x24, 0x23, 0x43, 0xAC, 0x4C, 0x23, 0x82,  
0x00, 0x23, 0xAE, 0x4C, 0xA3, 0x81, 0x93, 0x00, 0x19, 0x60, 0xAD, 0x4B, 0x1B, 0x88, 0xA4, 0x14,  
0x23, 0x40, 0x18, 0x46, 0xA6, 0x4B, 0x1B, 0x8A, 0x04, 0x24, 0xA3, 0x43, 0xA4, 0x4C, 0x23, 0x82,  
0xA8, 0x4B, 0xA6, 0x4C, 0xA3, 0x81, 0x10, 0xBD, 0x10, 0xB5, 0x02, 0x46, 0xA0, 0x4B, 0x1B, 0x8A,  
0x02, 0x24, 0x23, 0x43, 0x9E, 0x4C, 0x23, 0x82, 0x00, 0x23, 0xA0, 0x4C, 0xA3, 0x81, 0x11, 0x70,  
0x9F, 0x4B, 0x1B, 0x88, 0xA4, 0x14, 0x23, 0x40, 0x18, 0x46, 0x99, 0x4B, 0x1B, 0x8A, 0x02, 0x24,  
0xA3, 0x43, 0x97, 0x4C, 0x23, 0x82, 0x9B, 0x4B, 0x98, 0x4C, 0xA3, 0x81, 0x10, 0xBD, 0xF1, 0xB5,  
0x88, 0xB0, 0x08, 0x9D, 0x00, 0x20, 0x00, 0x90, 0x91, 0x48, 0x00, 0x8A, 0x08, 0x21, 0x88, 0x43,  
0x8F, 0x49, 0x08, 0x82, 0x8F, 0x48, 0x00, 0x88, 0x00, 0x07, 0x00, 0x0F, 0x03, 0x90, 0x8D, 0x48,  
0x40, 0x88, 0x02, 0x90, 0x8B, 0x48, 0x80, 0x88, 0x01, 0x90, 0x01, 0x99, 0x02, 0x98, 0x40, 0x18,  
0x40, 0x1E, 0x80, 0xB2, 0x05, 0x90, 0x05, 0x98, 0xC0, 0x13, 0x00, 0x28, 0x04, 0xD1, 0x01, 0x21,  
0xC9, 0x03, 0x05, 0x98, 0x08, 0x43, 0x05, 0x90, 0x02, 0x98, 0x07, 0x90, 0x01, 0x99, 0x07, 0x98,  
0x40, 0x18, 0x80, 0xB2, 0x07, 0x90, 0x00, 0x27, 0x08, 0xE0, 0x7E, 0x48, 0x08, 0x30, 0xC1, 0x5D,  
0x07, 0x98, 0x08, 0x18, 0x80, 0xB2, 0x07, 0x90, 0x78, 0x1C, 0x87, 0xB2, 0x01, 0x98, 0x87, 0x42,  
0xF3, 0xDB, 0x77, 0x49, 0x07, 0x98, 0x48, 0x82, 0x76, 0x48, 0xC1, 0x88, 0x07, 0x98, 0x81, 0x42,  
0x73, 0xD1, 0x03, 0x98, 0x01, 0x28, 0x01, 0xD1, 0x00, 0x20, 0x0C, 0xE0, 0x03, 0x98, 0x03, 0x28,  
0x01, 0xD1, 0x04, 0x20, 0x07, 0xE0, 0x03, 0x98, 0x05, 0x28, 0x01, 0xD1, 0x24, 0x20, 0x02, 0xE0,  
0x6F, 0x48, 0x20, 0x30, 0x00, 0x89, 0x6E, 0x49, 0x20, 0x31, 0x08, 0x81, 0x00, 0x27, 0xBE, 0xE0,  
0x02, 0x98, 0xC0, 0x19, 0x80, 0xB2, 0x06, 0x90, 0x30, 0x0A, 0x66, 0x49, 0x08, 0x31, 0xC9, 0x5D,  
0x09, 0x06, 0x08, 0x43, 0x06, 0x46, 0x06, 0x9C, 0x61, 0x48, 0xC7, 0x81, 0x60, 0x49, 0x06, 0x98,  
0x08, 0x80, 0x30, 0x0C, 0xC8, 0x80, 0x8E, 0x80, 0x06, 0x98, 0xC0, 0x13, 0x00, 0x28, 0x03, 0xD1,  
0x89, 0x13, 0x06, 0x98, 0x08, 0x43, 0x04, 0x46, 0x04, 0x98, 0x00, 0x0A, 0x21, 0x78, 0x09, 0x06,  
0x08, 0x43, 0x04, 0x90, 0x56, 0x48, 0x44, 0x80, 0x04, 0x98, 0x00, 0x0C, 0x54, 0x49, 0x48, 0x81,  
0x04, 0x98, 0x08, 0x81, 0x03, 0x98, 0x01, 0x28, 0x02, 0xD0, 0x03, 0x98, 0x03, 0x28, 0x16, 0xD1,  
0x04, 0x98, 0x00, 0x0E, 0x31, 0x0E, 0x88, 0x42, 0x0D, 0xD0, 0x31, 0x0E, 0x20, 0x46, 0xFF, 0xF7,  
0x53, 0xFF, 0x00, 0x28, 0x08, 0xD1, 0x20, 0x78, 0x04, 0x90, 0x31, 0x0E, 0x04, 0x98, 0x81, 0x42,  
0x79, 0xD0, 0x68, 0x1C, 0x85, 0xB2, 0x76, 0xE0, 0x68, 0x1C, 0x85, 0xB2, 0x73, 0xE0, 0x03, 0x98,  
0x05, 0x28, 0x70, 0xD1, 0xA0, 0x07, 0x80, 0x0F, 0x00, 0x28, 0x07, 0xD1, 0x01, 0x20, 0x00, 0x90,  
0x3F, 0x48, 0x00, 0x8A, 0x08, 0x21, 0x08, 0x43, 0x3D, 0x49, 0x08, 0x82, 0x42, 0x49, 0x05, 0x98,  
0x08, 0x40, 0xA0, 0x42, 0x02, 0xD1, 0x01, 0x20, 0x01, 0xE0, 0x65, 0xE0, 0x00, 0x20, 0x05, 0x99,  
0x89, 0x07, 0x89, 0x0F, 0x03, 0x29, 0x01, 0xD0, 0x01, 0x21, 0x00, 0xE0, 0x00, 0x21, 0x08, 0x40,  
0x00, 0x28, 0x07, 0xD0, 0x00, 0x20, 0x00, 0x90, 0x31, 0x48, 0x00, 0x8A, 0x08, 0x21, 0x88, 0x43,  
0x2F, 0x49, 0x08, 0x82, 0x00, 0x98, 0x00, 0x28, 0x20, 0xD1, 0x31, 0x48, 0x20, 0x30, 0x00, 0x89,  
0x20, 0x21, 0x88, 0x43, 0x2E, 0x49, 0x20, 0x31, 0x08, 0x81, 0x08, 0x46, 0x00, 0x89, 0x04, 0x21,  
0x08, 0x43, 0x2B, 0x49, 0x20, 0x31, 0x08, 0x81, 0x31, 0x0E, 0x20, 0x46, 0xFF, 0xF7, 0x04, 0xFF,  
0x00, 0x28, 0x08, 0xD1, 0x20, 0x78, 0x04, 0x90, 0x31, 0x0E, 0x04, 0x98, 0x81, 0x42, 0x2A, 0xD0,  
0x68, 0x1C, 0x85, 0xB2, 0x27, 0xE0, 0x68, 0x1C, 0x85, 0xB2, 0x24, 0xE0, 0xA0, 0x07, 0x80, 0x0F,  
0x03, 0x28, 0x20, 0xD1, 0x1E, 0x48, 0x20, 0x30, 0x00, 0x89, 0x20, 0x21, 0x08, 0x43, 0x1C, 0x49,  
0x20, 0x31, 0x08, 0x81, 0x08, 0x46, 0x00, 0x89, 0x04, 0x21, 0x08, 0x43, 0x18, 0x49, 0x20, 0x31,  
0x08, 0x81, 0xA0, 0x10, 0x31, 0x46, 0xFF, 0xF7, 0xC3, 0xFE, 0x00, 0x28, 0x09, 0xD1, 0xA0, 0x10,  
0x80, 0x00, 0x00, 0x68, 0x04, 0x90, 0x04, 0x98, 0xB0, 0x42, 0x04, 0xD0, 0x28, 0x1D, 0x85, 0xB2,  
0x01, 0xE0, 0x28, 0x1D, 0x85, 0xB2, 0x0A, 0x48, 0x85, 0x81, 0x78, 0x1C, 0x87, 0xB2, 0x01, 0x98,  
0x87, 0x42, 0x00, 0xDA, 0x3C, 0xE7, 0x06, 0xE0, 0x06, 0x48, 0x80, 0x88, 0x40, 0x19, 0x85, 0xB2,  
0x01, 0x20, 0xC0, 0x03, 0x05, 0x43, 0x28, 0x46, 0x09, 0xB0, 0xF0, 0xBD, 0x00, 0x70, 0x00, 0x40,  
0x00, 0x05, 0x00, 0x20, 0x00, 0x04, 0x00, 0x20, 0xB7, 0x1D, 0xC1, 0x04, 0x40, 0x30, 0x00, 0x40,

## MTP Programming Guide Application Note

---

0x00, 0x5C, 0x00, 0x40, 0xFF, 0x1F, 0x00, 0x00, 0xFC, 0xFF, 0x00, 0x00, 0x5A, 0x20, 0x44, 0x49,  
0x08, 0x80, 0x05, 0x20, 0x88, 0x80, 0x04, 0x20, 0x08, 0x81, 0x01, 0x20, 0x88, 0x81, 0x41, 0x48,  
0x08, 0x82, 0x32, 0x20, 0x40, 0x49, 0x08, 0x80, 0x94, 0x20, 0x40, 0x49, 0x08, 0x80, 0x15, 0x20,  
0x08, 0x80, 0x08, 0x46, 0x80, 0x8A, 0x60, 0x21, 0x88, 0x43, 0x3C, 0x49, 0x88, 0x82, 0x00, 0x20,  
0x3B, 0x49, 0x08, 0x80, 0x3B, 0x49, 0x08, 0x80, 0x48, 0x80, 0x00, 0x24, 0x00, 0x27, 0x01, 0x25,  
0x00, 0x26, 0x06, 0xE0, 0x00, 0x20, 0x71, 0x00, 0x37, 0x4A, 0x89, 0x18, 0x08, 0x80, 0x70, 0x1C,  
0x86, 0xB2, 0x10, 0x2E, 0xF6, 0xDB, 0x5A, 0xE0, 0x32, 0x48, 0x00, 0x88, 0xC0, 0x07, 0xC0, 0x0F,  
0x00, 0x28, 0x54, 0xD0, 0x2F, 0x48, 0x00, 0x88, 0xC0, 0xB2, 0x2E, 0x49, 0x08, 0x80, 0x5A, 0x20,  
0x2E, 0x49, 0x08, 0x82, 0x00, 0x20, 0x26, 0x49, 0x60, 0x31, 0x08, 0x80, 0x29, 0x48, 0x00, 0x88,  
0x11, 0x21, 0x08, 0x40, 0x01, 0x28, 0x27, 0xD1, 0x01, 0x25, 0x26, 0x48, 0x00, 0x88, 0xC0, 0xB2,  
0x29, 0x02, 0x08, 0x43, 0x23, 0x49, 0x08, 0x80, 0x23, 0x48, 0x00, 0x8A, 0x01, 0x21, 0x08, 0x43,  
0x21, 0x49, 0x08, 0x82, 0x00, 0x20, 0xFF, 0xF7, 0x72, 0xFE, 0x04, 0x46, 0x1E, 0x48, 0x00, 0x8A,  
0xA8, 0x43, 0x1D, 0x49, 0x08, 0x82, 0x60, 0x04, 0x40, 0x0C, 0xC0, 0x19, 0x87, 0xB2, 0x88, 0x13,  
0x20, 0x40, 0x00, 0x28, 0x01, 0xD0, 0x08, 0x20, 0x04, 0xE0, 0x00, 0x2C, 0x01, 0xD0, 0x04, 0x20,  
0x00, 0xE0, 0x02, 0x20, 0x05, 0x46, 0x11, 0xE0, 0x01, 0x25, 0x12, 0x48, 0x00, 0x88, 0xC0, 0xB2,  
0x29, 0x02, 0x08, 0x43, 0x0F, 0x49, 0x08, 0x80, 0x08, 0x88, 0xFF, 0xF7, 0x79, 0xFD, 0x04, 0x46,  
0x00, 0x2C, 0x01, 0xD0, 0x08, 0x20, 0x00, 0xE0, 0x02, 0x20, 0x05, 0x46, 0x09, 0x48, 0x47, 0x80,  
0x00, 0x88, 0xFE, 0x21, 0x08, 0x40, 0x29, 0x02, 0x08, 0x43, 0x06, 0x49, 0x08, 0x80, 0xA3, 0xE7,  
0x00, 0x30, 0x00, 0x40, 0xFF, 0x07, 0x00, 0x00, 0x40, 0x54, 0x00, 0x40, 0x00, 0x58, 0x00, 0x40,  
0x40, 0x6C, 0x00, 0x40, 0x00, 0x04, 0x00, 0x20, 0x00, 0x05, 0x00, 0x20, 0x40, 0x5C, 0x00, 0x40,  
0x70, 0x47, 0x70, 0x47, 0x70, 0x47, 0x75, 0x46, 0x00, 0xF0, 0x24, 0xF8, 0xAE, 0x46, 0x05, 0x00,  
0x69, 0x46, 0x53, 0x46, 0xC0, 0x08, 0xC0, 0x00, 0x85, 0x46, 0x18, 0xB0, 0x20, 0xB5, 0xFF, 0xF7,  
0x39, 0xFD, 0x60, 0xBC, 0x00, 0x27, 0x49, 0x08, 0xB6, 0x46, 0x00, 0x26, 0xC0, 0xC5, 0xC0, 0xC5,  
0xC0, 0xC5, 0xC0, 0xC5, 0xC0, 0xC5, 0xC0, 0xC5, 0xC0, 0xC5, 0xC0, 0xC5, 0x40, 0x3D, 0x49, 0x00,  
0x8D, 0x46, 0x70, 0x47, 0x10, 0xB5, 0x04, 0x46, 0xC0, 0x46, 0xC0, 0x46, 0x20, 0x46, 0xFF, 0xF7,  
0x14, 0xFD, 0x10, 0xBD, 0x00, 0x48, 0x70, 0x47, 0x00, 0x00, 0x00, 0x20, 0x01, 0x49, 0x18, 0x20,  
0xAB, 0xBE, 0xFE, 0xE7, 0x26, 0x00, 0x02, 0x00, 0x70, 0x47, 0x00, 0x00, 0x8C, 0x06, 0x00, 0x00,  
0x00, 0x00, 0x00, 0x20, 0x60, 0x01, 0x00, 0x00, 0x54, 0x00, 0x00, 0x00};

## 7. Revision History

Revision	Date	Description
2.50	April 10, 2020	Added a section for clarification of the power cycle in between MTP programming and CRC checking.
2.40	March 26, 2020	Updated VOut Bootloader which corresponds to p9415_mtp_utility_v0.7.
2.30	March 23, 2020	Updated VOut Bootloader which has TX mode current direction bit set. This Bootloader code corresponds to p9415_mtp_utility_v0.5.
2.20	February 20, 2020	GPIO Toggle is removed.
2.10	February 12, 2020	Added VRect Bootloader. GP configuration for modification of pins to input.
2.00	September 20, 2019	Remove deprecated source code.
1.00	Aug 15, 2019	Initial release to customer.

## IMPORTANT NOTICE AND DISCLAIMER

RENESAS ELECTRONICS CORPORATION AND ITS SUBSIDIARIES (“RENESAS”) PROVIDES TECHNICAL SPECIFICATIONS AND RELIABILITY DATA (INCLUDING DATASHEETS), DESIGN RESOURCES (INCLUDING REFERENCE DESIGNS), APPLICATION OR OTHER DESIGN ADVICE, WEB TOOLS, SAFETY INFORMATION, AND OTHER RESOURCES “AS IS” AND WITH ALL FAULTS, AND DISCLAIMS ALL WARRANTIES, EXPRESS OR IMPLIED, INCLUDING, WITHOUT LIMITATION, ANY IMPLIED WARRANTIES OF MERCHANTABILITY, FITNESS FOR A PARTICULAR PURPOSE, OR NON-INFRINGEMENT OF THIRD-PARTY INTELLECTUAL PROPERTY RIGHTS.

These resources are intended for developers who are designing with Renesas products. You are solely responsible for (1) selecting the appropriate products for your application, (2) designing, validating, and testing your application, and (3) ensuring your application meets applicable standards, and any other safety, security, or other requirements. These resources are subject to change without notice. Renesas grants you permission to use these resources only to develop an application that uses Renesas products. Other reproduction or use of these resources is strictly prohibited. No license is granted to any other Renesas intellectual property or to any third-party intellectual property. Renesas disclaims responsibility for, and you will fully indemnify Renesas and its representatives against, any claims, damages, costs, losses, or liabilities arising from your use of these resources. Renesas' products are provided only subject to Renesas' Terms and Conditions of Sale or other applicable terms agreed to in writing. No use of any Renesas resources expands or otherwise alters any applicable warranties or warranty disclaimers for these products.

(Disclaimer Rev.1.01)

### Corporate Headquarters

TOYOSU FORESIA, 3-2-24 Toyosu,  
Koto-ku, Tokyo 135-0061, Japan  
[www.renesas.com](http://www.renesas.com)

### Trademarks

Renesas and the Renesas logo are trademarks of Renesas Electronics Corporation. All trademarks and registered trademarks are the property of their respective owners.

### Contact Information

For further information on a product, technology, the most up-to-date version of a document, or your nearest sales office, please visit [www.renesas.com/contact-us/](http://www.renesas.com/contact-us/).