

# Errata

## SLG46116

### CE-GP-010

#### **Abstract**

*This document contains the known errata for SLG46116 and the recommended workarounds.*

---

## 1 Information

**Table 1: Information Table**

<b>Package(s)</b>	1.6 x 2.5 x 0.55 mm STQFN 14L
-------------------	-------------------------------

## 2 Errata Summary

**Table 2: Errata Summary**

<b>Issue #</b>	<b>Issue Title</b>
1	Long RC OSC Settling Time
2	Glitches on ACMP output
3	Delay Lock-up by a Short Pulse
4	Device Damage by High Input Voltage on External Vref PIN of ACMP
5	FILTER Cell Does not Filter out Glitches
6	Extra Short RC OSC Settling Time
7	OSC Long Start-Up Time
8	ACMP1 Output is always HIGH

## 3 Errata Details

### 3.1 Long RC OSC Settling Time

#### 3.1.1 Effect

RC OSC, Counter, Delay

#### 3.1.2 Conditions

RC OSC configured as 2 MHz with Auto Power On

#### 3.1.3 Technical Description

An example of such issue is in the following configuration:

The RC OSC has a longer settling time when configured as 2 MHz with Auto Power On in the designs that have very short RC OSC disable time.

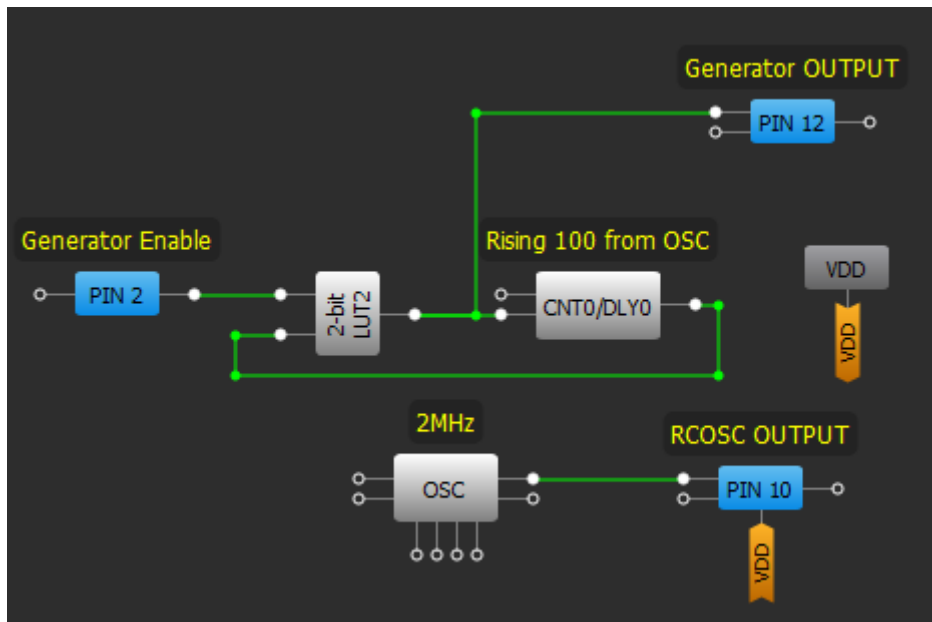

2-bit LUT2				
IN3	IN2	IN1	IN0	OUT
0	0	0	0	0
0	0	0	1	0
0	0	1	0	1
0	0	1	1	0

**RC OSC**

RC OSC Power register: Auto Power On

Clock selector: RC OSC

RC OSC Frequency: 2000.00 kHz

**14-bit CNT0/DLY0**

Mode: Delay

Counter data: 100  
(Range: 1 - 16383)

Delay time: 0.0512 ms [Formula](#)

Edge select: Rising

The configuration shown above generates a periodical signal with a frequency defined by the Delay cell and started by a HIGH signal on PIN2. The issue becomes apparent in a longer settling time when the scheme generates short pulses (Delay is configured as a rising edge delay only). See waveform below.

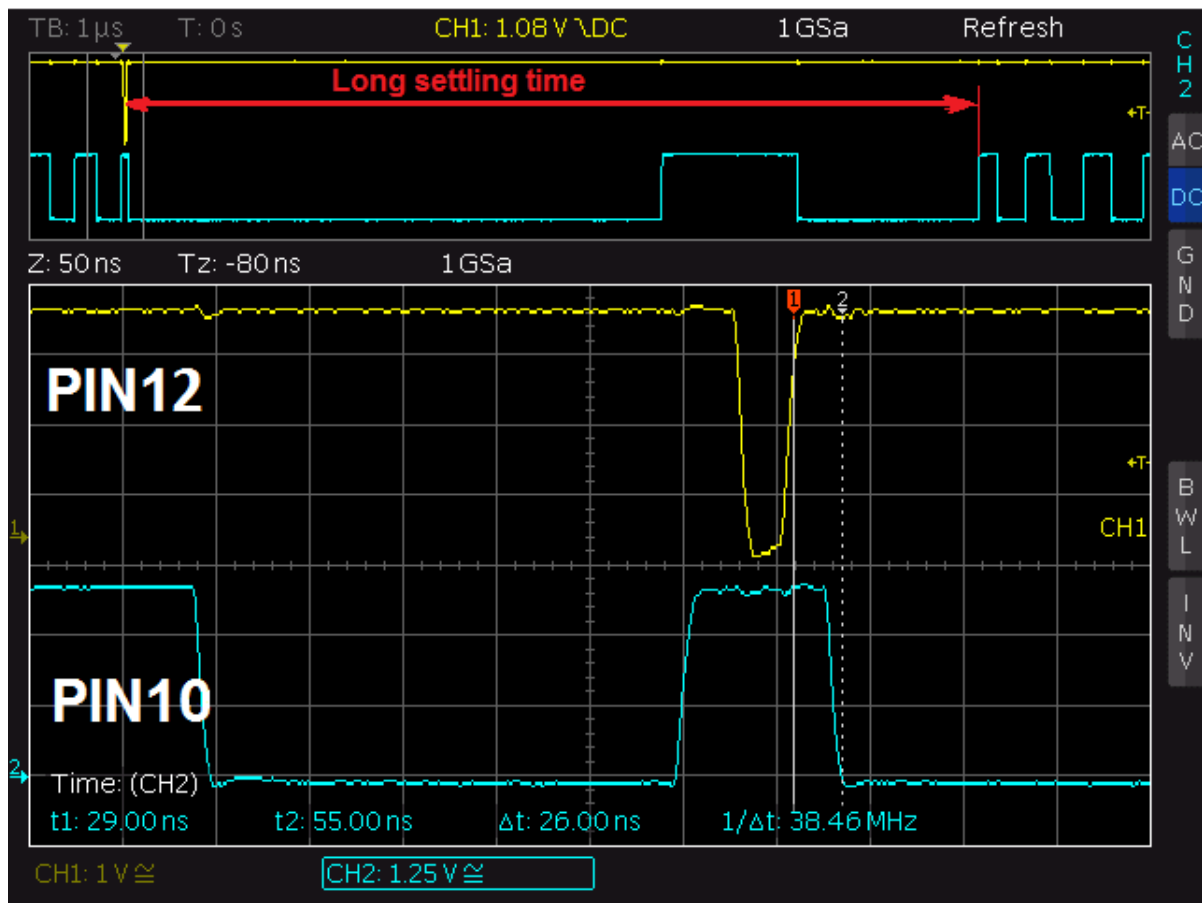

Channel 1 – 2-bit LUT0 output; Channel 2 – RC OSC output

Such behavior will lead to substantial error in period calculations if the delay time is relatively small.

The same situation occurs while using two connected delays (all edge detect types except for a pair “Rising edge DLY – Falling edge DLY”).

In the following example, Delay0 and Delay1 are configured in the same way. However, Delay1 time is 17.8us instead of expected 11.3us (Delay0 time).

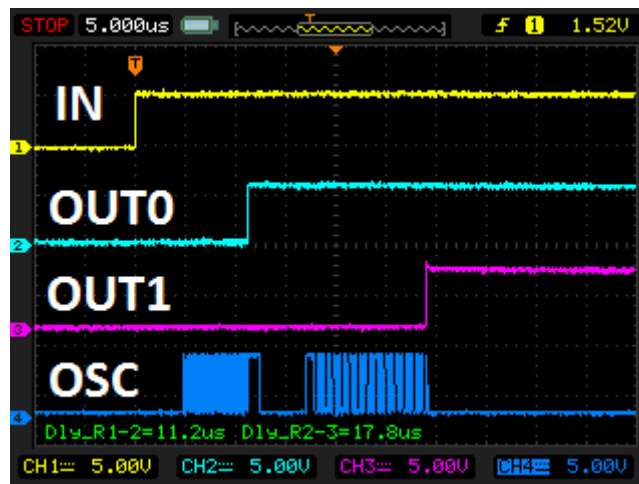
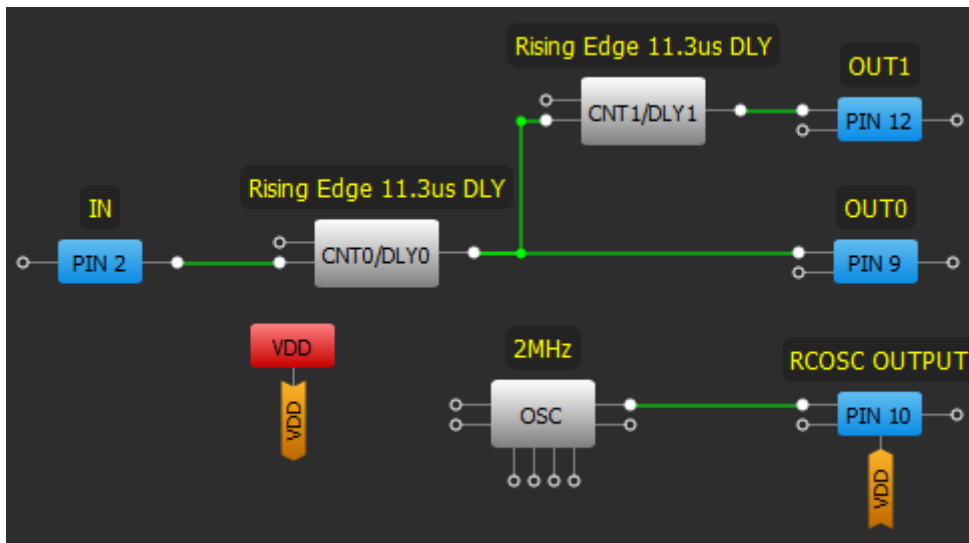

If there are some inner blocks which use RC OSC at the moment or RC OSC is forced power on when such error appears, RC OSC will be operational and delay value will be proper.

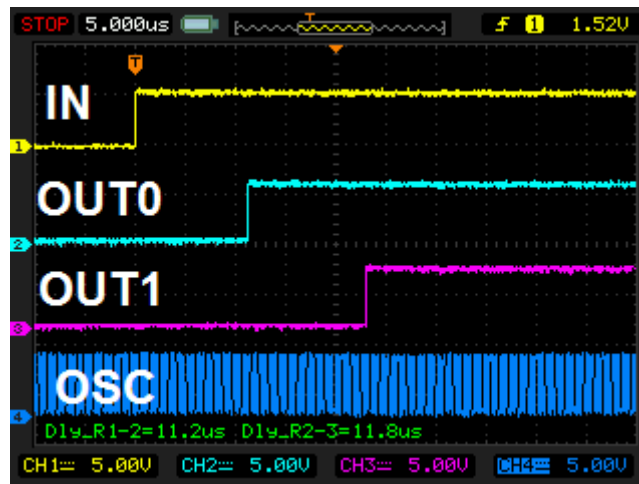

### 3.1.4 Workaround

- In first case use block with longer propagation time.

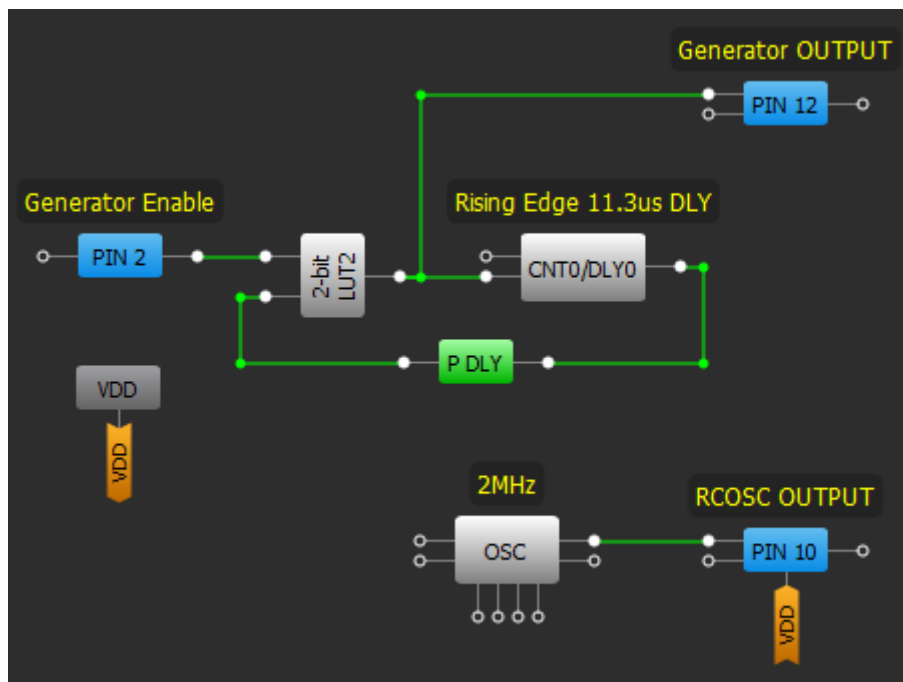

CE-GP-010

SLG46116

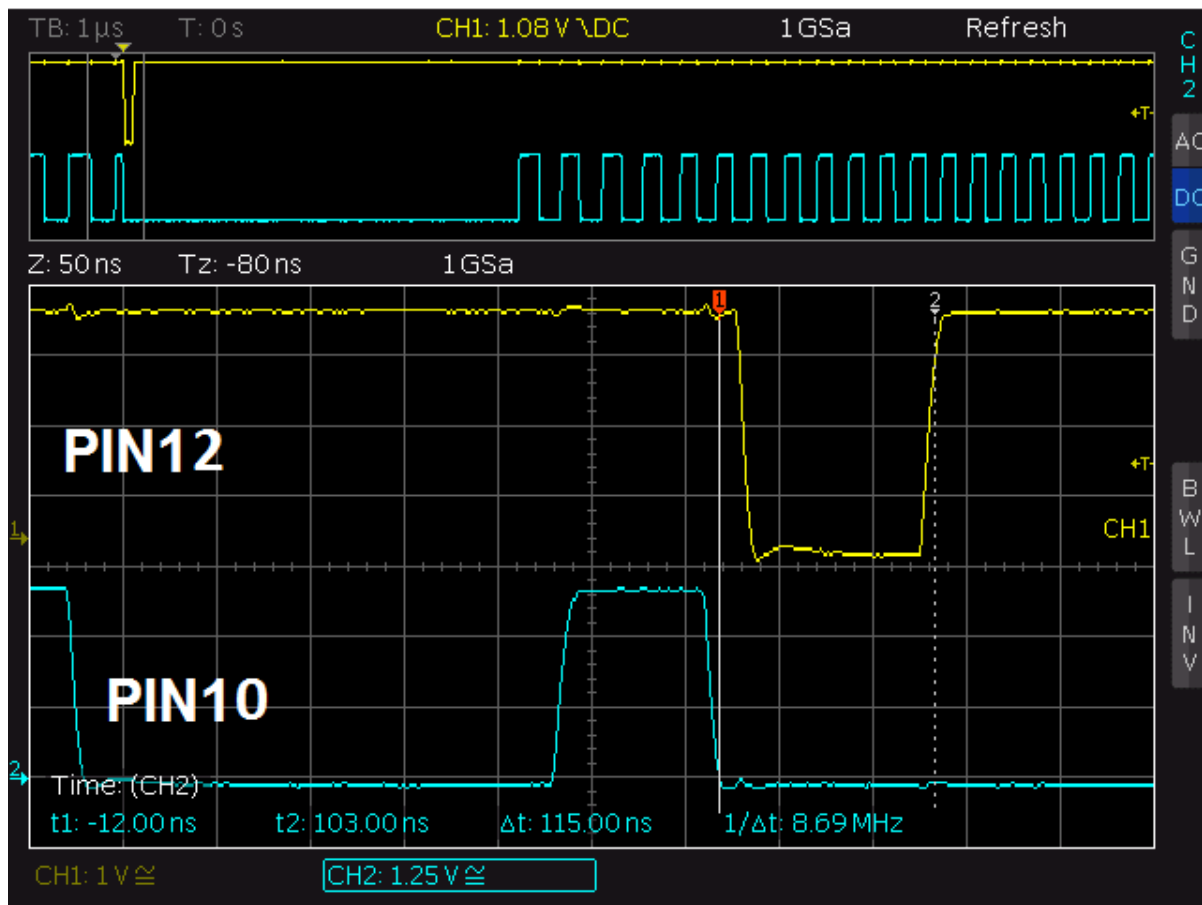

Channel 1 – 2-bit LUT0 output; Channel 2 – RC OSC output

- using two delays in series (except for a pair “Rising edge DLY – Falling edge DLY”) use one Filter cell or P DLY between delay blocks. Using LUTs won’t help in this case.

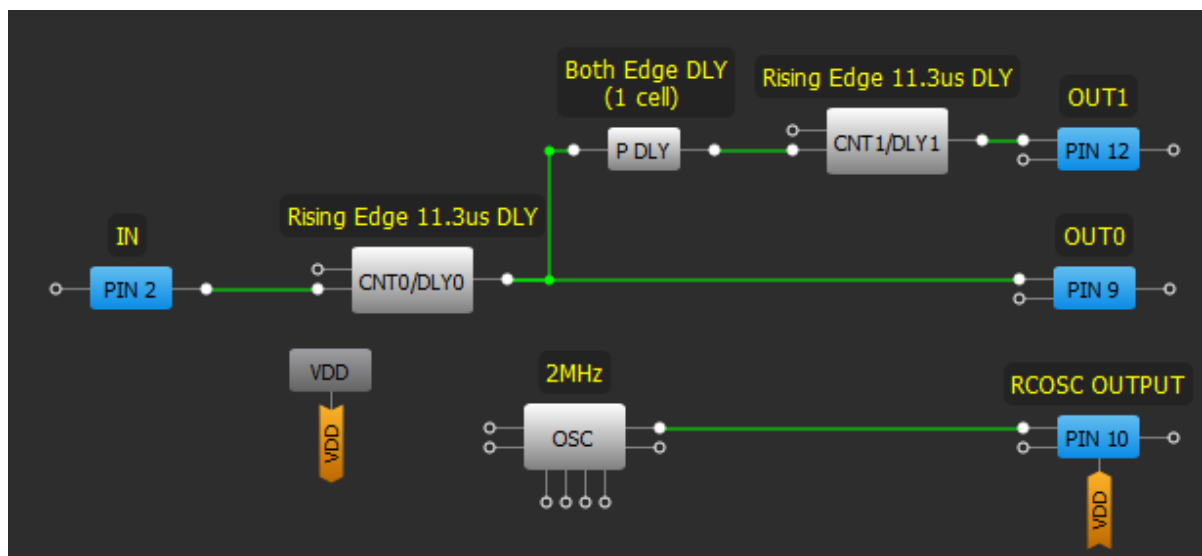

- use the “Force power on” RC OSC power control option to make the RC OSC operate at all times.

## CE-GP-010

### SLG46116

## 3.2 Glitches on ACMP output

### 3.2.1 Effect

ACMP

### 3.2.2 Conditions

Conditions of glitches appearing are determined by IN- voltage,  $V_{DD}$  value and  $V_{DD}$  Ramp (see example tables below).

IN- Voltage, mV	$V_{DD}$ , V	$V_{DD}$ Ramp Time	Glitch presence
50	1.8	10 us	+
50	1.8	1 s	-
50	3.3	10 us	+
50	3.3	1 s	+
50	5.5	10 us	+
50	5.5	1 s	+
600	1.8	10 us	-
600	1.8	1 s	-
600	3.3	10 us	+
600	3.3	1 s	-
600	5.5	10 us	+
600	5.5	1 s	-
1200	1.8	10 us	-
1200	1.8	1 s	-
1200	3.3	10 us	-
1200	3.3	1 s	-
1200	5.5	10 us	+
1200	5.5	1 s	-

### 3.2.3 Technical Description

In some cases, ACMP may have short high-level glitches on its output (even if IN+ voltage is less than IN- voltage) after GreenPAK chip being powered up. Such cases may appear when using ACMP with Low Bandwidth mode enabled and Power Up is connected directly to the  $V_{DD}$ .

In order to detect such glitches, scheme with additional LUT was used. This LUT detects high level on ACMP output and stays high until chip powers down.

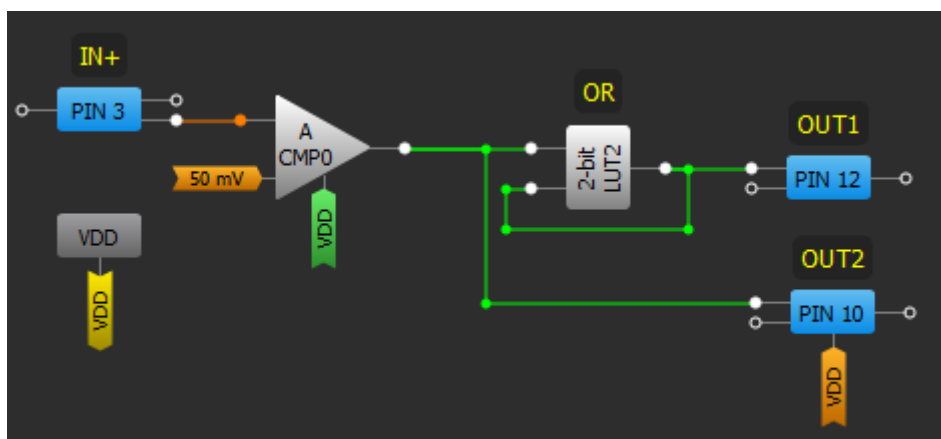

ACMP IN+ is connected to the Ground.

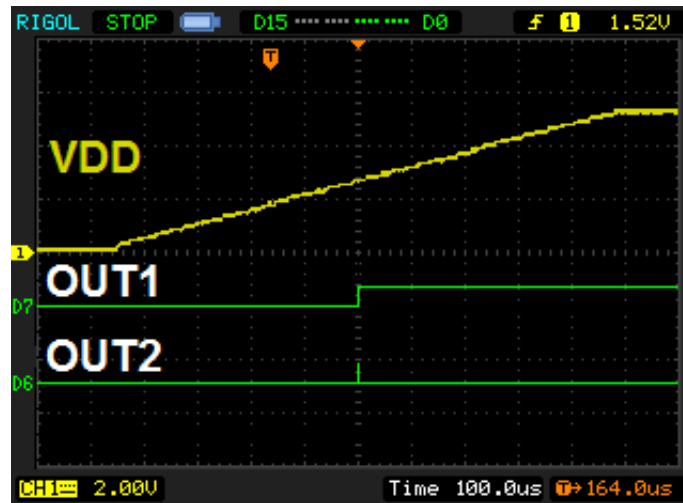

### 3.2.4 Workaround

Use POR block, connected to the ACMP's Power Up pin. However, in this case ACMP will start working with low level output and will be able to go high only after POR goes high + ACMP power on time.

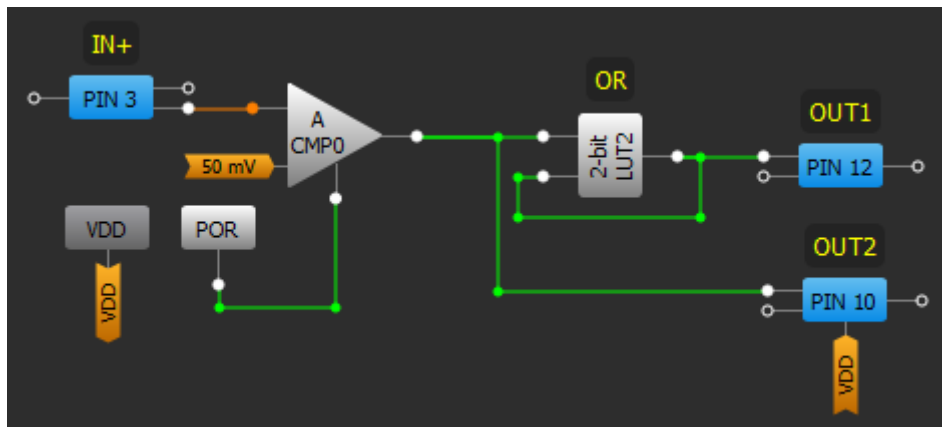

## 3.3 Delay Lock-up by a Short Pulse

### 3.3.1 Effect

Delay

### 3.3.2 Conditions

When a short pulse appears on Delay input

### 3.3.3 Technical Description

The delay output could be latched despite the input change when a short pulse is input. For example, if the delay cell is configured as a falling edge delay, the short pulse (see NOTE) appears on its input the delay cell output will switch from LOW to HIGH but may not switch from HIGH to LOW even after the delay time has passed.

NOTE: The pulse width varies from chip to chip and with different  $V_{DD}$  voltage. It is in range of 5-15ns and in the window  $\pm 0.2ns$ , so it should be very precise for issue happen.

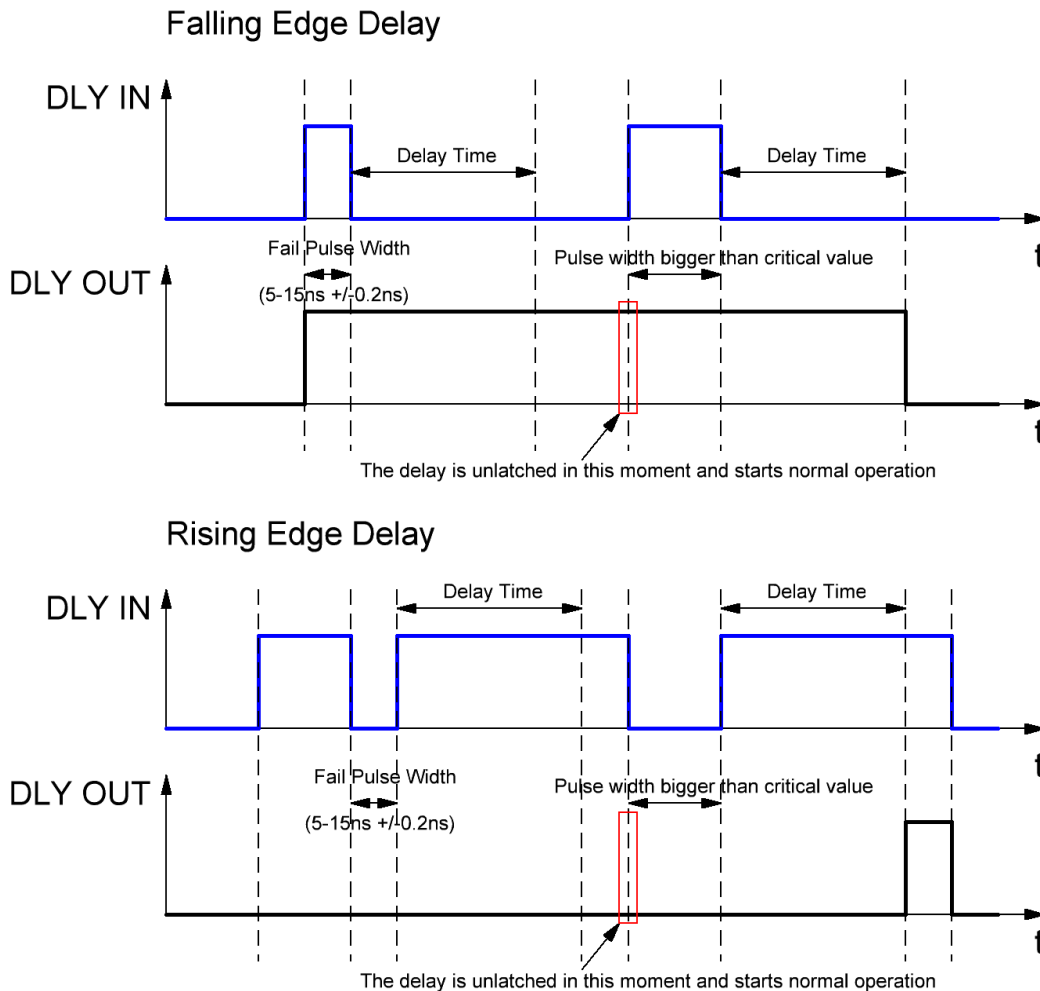

Also, note that both edge delays do not have such issue.

### 3.3.4 Workaround

Use P DLY/FILTER block configured as a both edge delay or FILTER.

## 3.4 Device Damage by High Input Voltage on External Vref PIN of ACMP

### 3.4.1 Effect

ACMPs

### 3.4.2 Conditions

Voltage higher than 2 V applied to IN- of ACMP as an external reference voltage.

### 3.4.3 Technical Description

The device may be damaged by the voltage higher than 2V applied to IN- of ACMP as an external reference voltage.

## CE-GP-010

### SLG46116

#### 3.4.4 Workaround

There is no workaround to this issue, avoid applying more than 2V on IN- of ACMP used as external voltage reference.

### 3.5 FILTER Cell Does not Filter out Glitches

#### 3.5.1 Effect

Filter

#### 3.5.2 Conditions

If clock type high frequency input comes in

#### 3.5.3 Technical Description

If clock type high frequency input comes in, the FILTER cell may not filter out it. There are several factors like input frequency, duty cycle and LOW duration in such signal that may lead to its passing through FILTER block.

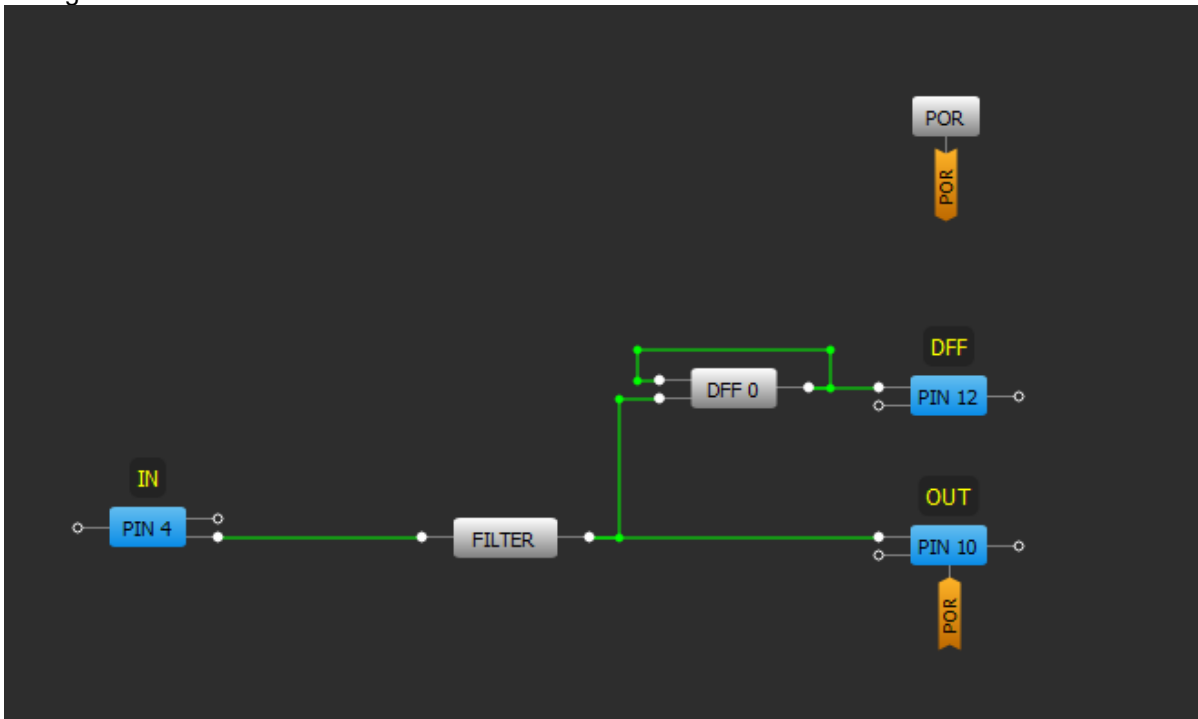

Channel 1 (yellow/top line) – PIN#4 (IN)  
 Channel 2 (light blue/2nd line) – PIN#10 (OUT)  
 Channel 3 (magenta /3rd line) – PIN#12 (DFF)

CE-GP-010

SLG46116

1. Period is 60ns. Pulse width is 10ns DC=16.7% (Correct functionality)



2. Period is 60ns. Pulse width is 20ns DC = 33.3% (Incorrect functionality)



3. Period is 60ns. Pulse width is 30ns DC=50% (Incorrect functionality)



4. Period is 60ns. Pulse width is 40ns DC=66.67% (Correct functionality)

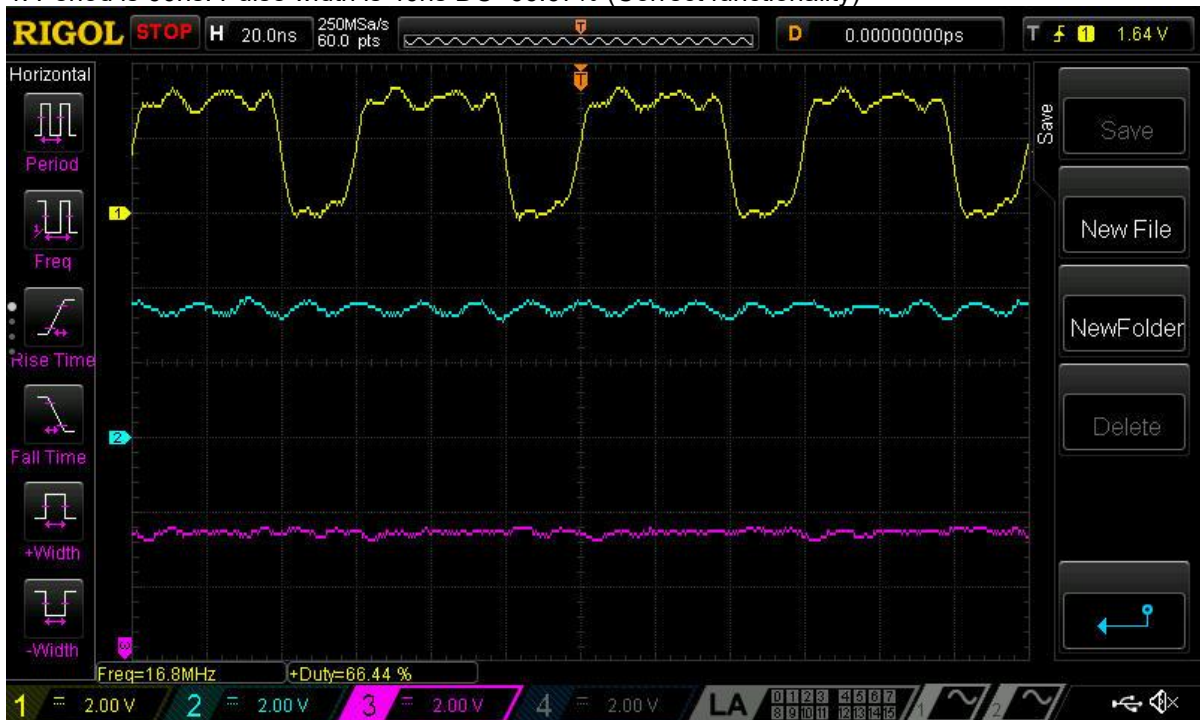

### 3.5.4 Workaround

Currently there is no workaround for this issue. Filter block is good at filtering short spontaneous glitches. It is intended to be used in series connection before the delay cell to avoid its latching (see issue #5).

### 3.6 Extra Short RC OSC Settling Time

#### 3.6.1 Effect

RC OSC, Counter, Delay

#### 3.6.2 Conditions

OSC configured as 25 kHz with Auto Power On

#### 3.6.3 Technical Description

The first period of the RC OSC can be very short when OSC configured as 25 kHz with Auto Power On in the designs. This can be occurred when  $V_{DD}$  is above 4.0 V. Critical for CNT/DLY with a low counter data (less than 10) or if it is necessary to use the frequency of the OSC to clock external elements.

An example of such issue is in the following configuration:

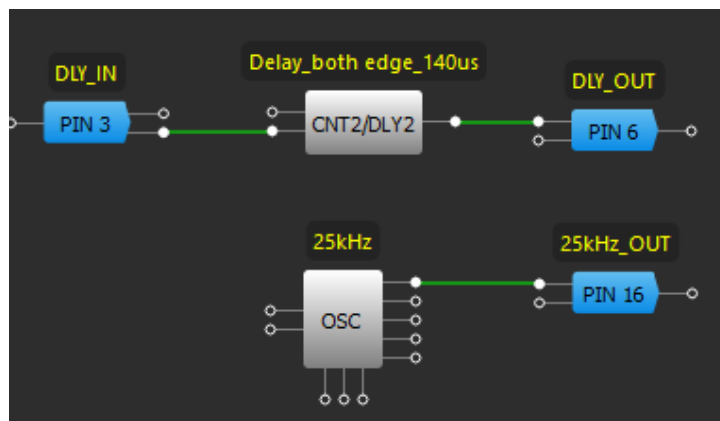

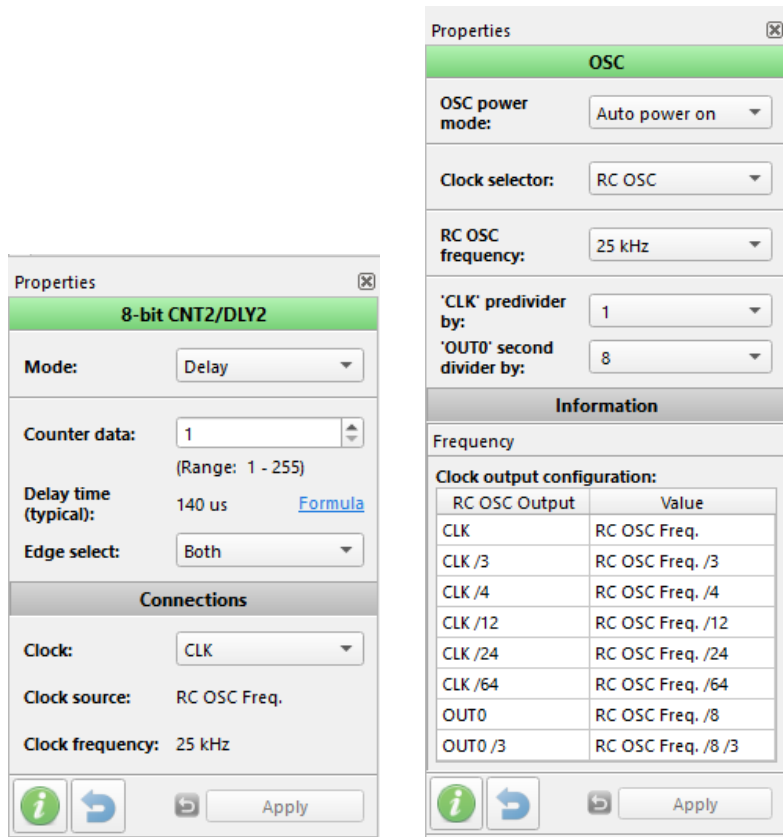

Normal oscillator behavior.

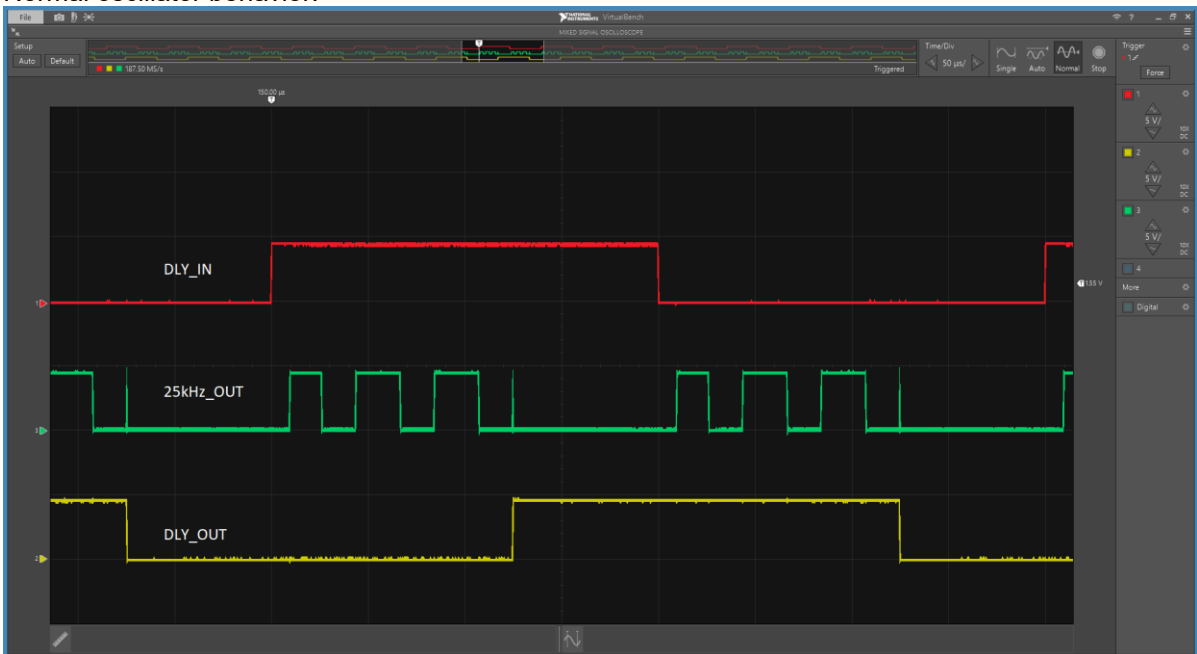

## CE-GP-010

### SLG46116

Abnormal oscillator behavior.



#### 3.6.4 Workaround

- Avoid  $V_{DD}$  higher than 4 V
- Force ON OSC

### 3.7 OSC Long Start-Up Time

#### 3.7.1 Effect:

When a short pulse is applied to the PWR DOWN input, the oscillator exhibits a long start-up time.

#### 3.7.2 Conditions

When a short pulse of less than ~40 ns is applied to the PWR DOWN input.

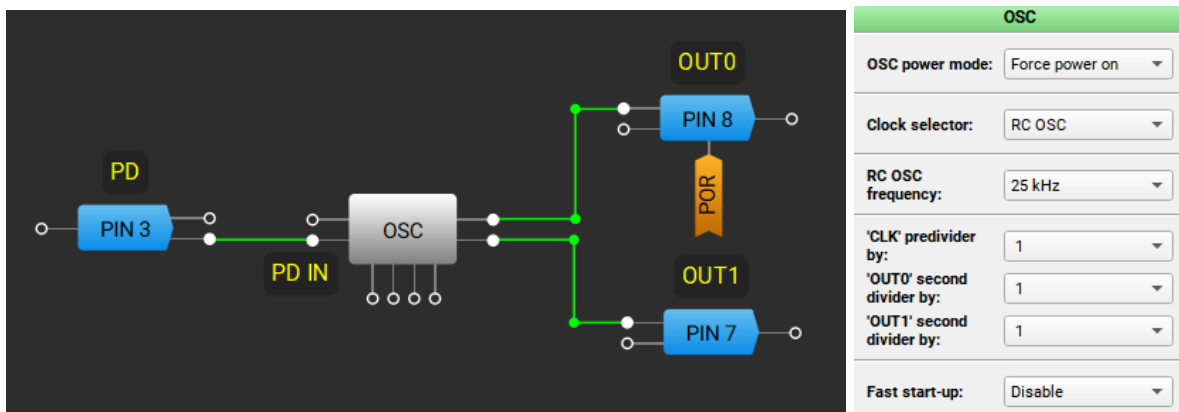

#### 3.7.3 Technical Description

If a pulse with a duration of less than ~40 ns is applied to the PWR DOWN input of the oscillator, the oscillator outputs remain stuck for milliseconds, as shown in figures below. This issue is observed for both 25 kHz and 2 MHz oscillators.



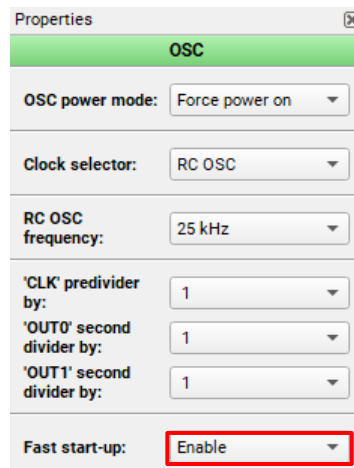

### 3.8 ACMP1 Output is always HIGH

#### 3.8.1 Effect

ACMP1

#### 3.8.2 Conditions

When the gain is not equal to 1, and the 100  $\mu$ A pull-up on the input is enabled

#### 3.8.3 Technical Description:

If the "IN+ gain" setting is not disabled (that is, any of the x0.25, x0.33, or x0.5 settings is selected) and the "100  $\mu$ A pullup on input" setting is enabled, the ACMP1 output goes HIGH immediately upon power-up. The output remains in this HIGH state regardless of the voltage levels applied to the ACMP1 IN+ pin.

#### 3.8.4 Workaround

Currently, there is no workaround for this issue.

**Document Revision History**

<b>Revision</b>	<b>Date</b>	<b>Description</b>
1.3	2-Feb-2026	Added issues #8
1.2	19-Dec-2024	Added issues #7
1.1	8-Mar-2022	Fixed typos Renesas rebranding
1.0	30-Dec-2021	Added issues #6 Updated according to Dialog's format

**Status Definitions**

<b>Status</b>	<b>Definition</b>
DRAFT	The content of this document is under review and subject to formal approval, which may result in modifications or additions.
APPROVED or unmarked	The content of this document has been approved for publication.