

RA8D2 Group

Evaluation Kit for RA8D2 Microcontroller Group
EK-RA8D2 v1
Errata

Renesas RA Family
RA8 Series

All information contained in these materials, including products and product specifications, represents information on the product at the time of publication and is subject to change by Renesas Electronics Corp. without notice. Please review the latest information published by Renesas Electronics Corp. through various means, including the Renesas Electronics Corp. website (<https://www.renesas.com>).

Notice

1. Descriptions of circuits, software and other related information in this document are provided only to illustrate the operation of semiconductor products and application examples. You are fully responsible for the incorporation or any other use of the circuits, software, and information in the design of your product or system. Renesas Electronics disclaims any and all liability for any losses and damages incurred by you or third parties arising from the use of these circuits, software, or information.
2. Renesas Electronics hereby expressly disclaims any warranties against and liability for infringement or any other claims involving patents, copyrights, or other intellectual property rights of third parties, by or arising from the use of Renesas Electronics products or technical information described in this document, including but not limited to, the product data, drawings, charts, programs, algorithms, and application examples.
3. No license, express, implied or otherwise, is granted hereby under any patents, copyrights or other intellectual property rights of Renesas Electronics or others.
4. You shall be responsible for determining what licenses are required from any third parties, and obtaining such licenses for the lawful import, export, manufacture, sales, utilization, distribution or other disposal of any products incorporating Renesas Electronics products, if required.
5. You shall not alter, modify, copy, or reverse engineer any Renesas Electronics product, whether in whole or in part. Renesas Electronics disclaims any and all liability for any losses or damages incurred by you or third parties arising from such alteration, modification, copying or reverse engineering.
6. Renesas Electronics products are classified according to the following two quality grades: "Standard" and "High Quality". The intended applications for each Renesas Electronics product depends on the product's quality grade, as indicated below.

"Standard": Computers; office equipment; communications equipment; test and measurement equipment; audio and visual equipment; home electronic appliances; machine tools; personal electronic equipment; industrial robots; etc.

"High Quality": Transportation equipment (automobiles, trains, ships, etc.); traffic control (traffic lights); large-scale communication equipment; key financial terminal systems; safety control equipment; etc.

Unless expressly designated as a high reliability product or a product for harsh environments in a Renesas Electronics data sheet or other Renesas Electronics document, Renesas Electronics products are not intended or authorized for use in products or systems that may pose a direct threat to human life or bodily injury (artificial life support devices or systems; surgical implantations; etc.), or may cause serious property damage (space system; undersea repeaters; nuclear power control systems; aircraft control systems; key plant systems; military equipment; etc.). Renesas Electronics disclaims any and all liability for any damages or losses incurred by you or any third parties arising from the use of any Renesas Electronics product that is inconsistent with any Renesas Electronics data sheet, user's manual or other Renesas Electronics document.
7. No semiconductor product is absolutely secure. Notwithstanding any security measures or features that may be implemented in Renesas Electronics hardware or software products, Renesas Electronics shall have absolutely no liability arising out of any vulnerability or security breach, including but not limited to any unauthorized access to or use of a Renesas Electronics product or a system that uses a Renesas Electronics product. RENESAS ELECTRONICS DOES NOT WARRANT OR GUARANTEE THAT RENESAS ELECTRONICS PRODUCTS, OR ANY SYSTEMS CREATED USING RENESAS ELECTRONICS PRODUCTS WILL BE INVULNERABLE OR FREE FROM CORRUPTION, ATTACK, VIRUSES, INTERFERENCE, HACKING, DATA LOSS OR THEFT, OR OTHER SECURITY INTRUSION ("Vulnerability Issues"). RENESAS ELECTRONICS DISCLAIMS ANY AND ALL RESPONSIBILITY OR LIABILITY ARISING FROM OR RELATED TO ANY VULNERABILITY ISSUES. FURTHERMORE, TO THE EXTENT PERMITTED BY APPLICABLE LAW, RENESAS ELECTRONICS DISCLAIMS ANY AND ALL WARRANTIES, EXPRESS OR IMPLIED, WITH RESPECT TO THIS DOCUMENT AND ANY RELATED OR ACCOMPANYING SOFTWARE OR HARDWARE, INCLUDING BUT NOT LIMITED TO THE IMPLIED WARRANTIES OF MERCHANTABILITY, OR FITNESS FOR A PARTICULAR PURPOSE.
8. When using Renesas Electronics products, refer to the latest product information (data sheets, user's manuals, application notes, "General Notes for Handling and Using Semiconductor Devices" in the reliability handbook, etc.), and ensure that usage conditions are within the ranges specified by Renesas Electronics with respect to maximum ratings, operating power supply voltage range, heat dissipation characteristics, installation, etc. Renesas Electronics disclaims any and all liability for any malfunctions, failure or accident arising out of the use of Renesas Electronics products outside of such specified ranges.
9. Although Renesas Electronics endeavors to improve the quality and reliability of Renesas Electronics products, semiconductor products have specific characteristics, such as the occurrence of failure at a certain rate and malfunctions under certain use conditions. Unless designated as a high reliability product or a product for harsh environments in a Renesas Electronics data sheet or other Renesas Electronics document, Renesas Electronics products are not subject to radiation resistance design. You are responsible for implementing safety measures to guard against the possibility of bodily injury, injury or damage caused by fire, and/or danger to the public in the event of a failure or malfunction of Renesas Electronics products, such as safety design for hardware and software, including but not limited to redundancy, fire control and malfunction prevention, appropriate treatment for aging degradation or any other appropriate measures. Because the evaluation of microcomputer software alone is very difficult and impractical, you are responsible for evaluating the safety of the final products or systems manufactured by you.
10. Please contact a Renesas Electronics sales office for details as to environmental matters such as the environmental compatibility of each Renesas Electronics product. You are responsible for carefully and sufficiently investigating applicable laws and regulations that regulate the inclusion or use of controlled substances, including without limitation, the EU RoHS Directive, and using Renesas Electronics products in compliance with all these applicable laws and regulations. Renesas Electronics disclaims any and all liability for damages or losses occurring as a result of your noncompliance with applicable laws and regulations.
11. Renesas Electronics products and technologies shall not be used for or incorporated into any products or systems whose manufacture, use, or sale is prohibited under any applicable domestic or foreign laws or regulations. You shall comply with any applicable export control laws and regulations promulgated and administered by the governments of any countries asserting jurisdiction over the parties or transactions.
12. It is the responsibility of the buyer or distributor of Renesas Electronics products, or any other party who distributes, disposes of, or otherwise sells or transfers the product to a third party, to notify such third party in advance of the contents and conditions set forth in this document.
13. This document shall not be reprinted, reproduced or duplicated in any form, in whole or in part, without prior written consent of Renesas Electronics.
14. Please contact a Renesas Electronics sales office if you have any questions regarding the information contained in this document or Renesas Electronics products.

(Note1) "Renesas Electronics" as used in this document means Renesas Electronics Corporation and also includes its directly or indirectly controlled subsidiaries.

(Note2) "Renesas Electronics product(s)" means any product developed or manufactured by or for Renesas Electronics.

(Rev.5.0-1 October 2020)

Corporate Headquarters

TOYOSU FORESIA, 3-2-24 Toyosu,
Koto-ku, Tokyo 135-0061, Japan

www.renesas.com

Trademarks

Renesas and the Renesas logo are trademarks of Renesas Electronics Corporation. All trademarks and registered trademarks are the property of their respective owners.

Contact information

For further information on a product, technology, the most up-to-date version of a document, or your nearest sales office, please visit:

www.renesas.com/contact/.

Renesas EK-RA8D2 Disclaimer

By using this EK-RA8D2, the User accepts the following terms, which are in addition to, and control in the event of disagreement, with Renesas' General Terms and Conditions available at [renesas.com/legal-notices](https://www.renesas.com/legal-notices).

The EK-RA8D2 is not guaranteed to be error free, and the entire risk as to the results and performance of the EK-RA8D2 is assumed by the User. The EK-RA8D2 is provided by Renesas on an "as is" basis without warranty of any kind whether express or implied, including but not limited to the implied warranties of good workmanship, fitness for a particular purpose, title, merchantability, and non-infringement of intellectual property rights. Renesas expressly disclaims any implied warranty.

Renesas does not consider the EK-RA8D2 to be a finished product and therefore the EK-RA8D2 may not comply with some requirements applicable to finished products, including, but not limited to recycling, restricted substances and electromagnetic compatibility regulations. Refer to Certifications section, for information about certifications and compliance information for the EK-RA8D2. It is the kit User's responsibility to make sure the kit meets any local requirements applicable to their region.

Renesas or its affiliates shall in no event be liable for any loss of profit, loss of data, loss of contract, loss of business, damage to reputation or goodwill, any economic loss, any reprogramming or recall costs (whether the foregoing losses are direct or indirect) nor shall Renesas or its affiliates be liable for any other direct or indirect special, incidental or consequential damages arising out of or in relation to the use of this EK-RA8D2, even if Renesas or its affiliates have been advised of the possibility of such damages.

Renesas has used reasonable care in preparing the information included in this document, but Renesas does not warrant that such information is error free nor does Renesas guarantee an exact match for every application or parameter to part numbers designated by other vendors listed herein. The information provided in this document is intended solely to enable the use of Renesas products. No express or implied license to any intellectual property right is granted by this document or in connection with the sale of Renesas products. Renesas reserves the right to make changes to specifications and product descriptions at any time without notice. Renesas assumes no liability for any damages incurred by you resulting from errors in or omissions from the information included herein. Renesas cannot verify, and assumes no liability for, the accuracy of information available on another company's website.

Precautions

This Evaluation Kit is only intended for use in a laboratory environment under ambient temperature and humidity conditions. A safe separation distance should be used between this and any sensitive equipment. Its use outside the laboratory, classroom, study area, or similar such area invalidates conformity with the protection requirements of the Electromagnetic Compatibility Directive and could lead to prosecution.

The product generates, uses, and can radiate radio frequency energy and may cause harmful interference to radio communications. There is no guarantee that interference will not occur in a particular installation. If this equipment causes harmful interference to radio or television reception, which can be determined by turning the equipment off or on, you are encouraged to try to correct the interference by one or more of the following measures:

- Ensure attached cables do not lie across the equipment.
- Reorient the receiving antenna.
- Increase the distance between the equipment and the receiver.
- Connect the equipment into an outlet on a circuit different from that which the receiver is connected.
- Power down the equipment when not in use.
- Consult the dealer or an experienced radio/TV technician for help.

Note: It is recommended that wherever possible shielded interface cables are used.

The product is potentially susceptible to certain EMC phenomena. To mitigate against them it is recommended that the following measures be undertaken:

- The user is advised that mobile phones should not be used within 10 m of the product when in use.
- The user is advised to take ESD precautions when handling the equipment.

The Evaluation Kit does not represent an ideal reference design for an end product and does not fulfill the regulatory standards for an end product.

Renesas RA Family

EK-RA8D2 v1

Contents

Corporate Headquarters	2
Contact information.....	2
Trademarks.....	2
1. Introduction.....	6
2. Known Issues and Exceptions	6
2.1 I3C SCL Controlled PU (P013) Only Supports Low Drive Strength.....	6
2.1.1 Description.....	6
2.1.2 Corrective Action	6
2.1.3 Kits Affected	6
2.2 Inaccuracy in RTC (Real Time Clock).....	7
2.2.1 Description.....	7
2.2.2 Corrective Action	7
2.2.3 Kits Affected	7
2.3 Incorrectly Calibrated Touch Panel	8
2.3.1 Description.....	8
2.3.2 Corrective Action	8
2.3.3 Kits Affected	9
3. Appendix – Kit Identification.....	10
3.1 Kit Version	10
3.2 Parallel Graphics Expansion Board Version	10
3.3 Serial Number.....	11
4. Website and Support	11
Revision History	12

Figures

Figure 1. I/O Register Settings for PORT0.....	6
Figure 2. Crystal Oscillator with Incorrect Load Capacitance.....	7
Figure 3. Touch Position Mapping Error.....	8
Figure 4. Touch Position Mapping Correct.....	8
Figure 5. Renesas Flash Programmer Operation	9
Figure 6. Identification of the Kit Version Number on the EK-RA8D2 Board	10

Figure 7. Identification of the Kit Version Number on the Parallel Graphics Expansion Board..... 10
Figure 8. Identification of the Serial Number on the EK-RA8D2 Board..... 11

1. Introduction

This Errata describes the known issues and exceptions to the functional specifications for the EK-RA8D2 v1, Evaluation Kit for the RA8D2 MCU Group. For additional information on the kit, see the EK-RA8D2 v1 User’s Manual.

2. Known Issues and Exceptions

2.1 I3C SCL Controlled PU (P013) Only Supports Low Drive Strength

2.1.1 Description

I3C can require the use of an active pull-up. This capability is provided on the current design using P013. This pin, used to pull up the SCL signal, supports Low Drive Strength only as shown in the table extract from the device hardware manual r01uh1065ej.

While this pin will work, it may not have the capability needed for the highest speed I3C communication.

A future revision of the board will move this connection to a pin capable of High drive strength.

Table 20.7 Register settings for input/output pin function (PORT0)

Pin	PSEL[4:0] settings	Function	Pin														
			P000	P001	P002	P003	P004	P005	P007	P008	P009	P010	P011	P012	P013	P014	P015
Hi-Z	00000b (value after reset)	Hi-Z/ JTAG/ SWD	Hi-Z	Hi-Z	Hi-Z	Hi-Z	Hi-Z	Hi-Z	Hi-Z	Hi-Z	Hi-Z	Hi-Z	Hi-Z	Hi-Z	Hi-Z	Hi-Z	Hi-Z
AN006/ IVCMP 2	ASEL bit		AN000/ IVCMP 2	AN001/ IVCMP 3	AN002/ IVCMP 2	AN003/ IVCMP 3	AN004/ IVCMP 2	AN005/ IVCMP 3	AN007/ IVCMP 3	AN008/ IVREF0	AN009/ IVREF1	AN010	AN011	AN012	AN013	AN014/ DA0/ IVCMP 0	AN015/ DA1/ IVCMP 0
IRQ11- DS	ISEL bit		IRQ6- DS	IRQ7- DS	IRQ8- DS	IRQ29	IRQ9- DS	IRQ10- DS	IRQ28	IRQ12- DS	IRQ13- DS	IRQ14	IRQ16	IRQ15	IRQ14	IRQ27	IRQ13
✓	PCR bit	Pull-up	✓	✓	✓	✓	✓	✓	✓	✓	✓	✓	✓	✓	✓	✓	✓
✓	NCODR bit	N-ch Open- drain	✓	✓	✓	✓	✓	✓	✓	✓	✓	✓	✓	✓	✓	✓	✓
L	DSCR[1:0] bit	Drive capability control ¹	L	L	L	L	L	L	L	L	L	L	L	L	L	L	L
✓	289 pins product		✓	✓	✓	✓	✓	✓	✓	✓	✓	✓	✓	✓	✓	✓	✓
✓	289 pins w/o MIPI product		✓	✓	✓	✓	✓	✓	✓	✓	✓	✓	✓	✓	✓	✓	✓
✓	224 pins product		✓	✓	✓	✓	✓	✓	✓	✓	✓	✓	✓	✓	✓	✓	✓
✓	224 pins w/o MIPI product		✓	✓	✓	✓	✓	✓	✓	✓	✓	✓	✓	✓	✓	✓	✓

✓: Available
 -: Setting prohibited

Note 1. The drive strength of this port cannot be controlled by PmnPFS.DSCR[1:0] bits.

Figure 1. I/O Register Settings for PORT0

2.1.2 Corrective Action

[Affected Kits]

To address this the user can connect a resistor to the SCL line via the connections on Arduino, Mikrobus, Grove1 or QWIIC connectors and the other end of the resistor to a suitable high drive strength capable port pin that is not used for other functions.

We suggest using port P311 as this pin is capable and is otherwise unused. It is accessible on J17 Pin 3

When implementing this configuration ensure that P013 is set to high impedance.

[Future Kits]

This issue will be corrected in later versions of the kit.

2.1.3 Kits Affected

Version:	1
Serial numbers:	301863 to 302162 and 32855 to 33354

2.2 Inaccuracy in RTC (Real Time Clock)

2.2.1 Description

Due to incorrectly specified crystal load capacitance and capacitors C22 and C23 the RTC can be inaccurate in the order of 10 seconds every 24 hours. This is because the fitted crystal ABS07-32.768KHZ-9-T requires a 9pF load capacitance C_L , given by the formula $C22=C23=2*(C_L-C_{stray})$, and so the load capacitors C22 and C23 should be significantly lower values than the fitted 27pF capacitors.

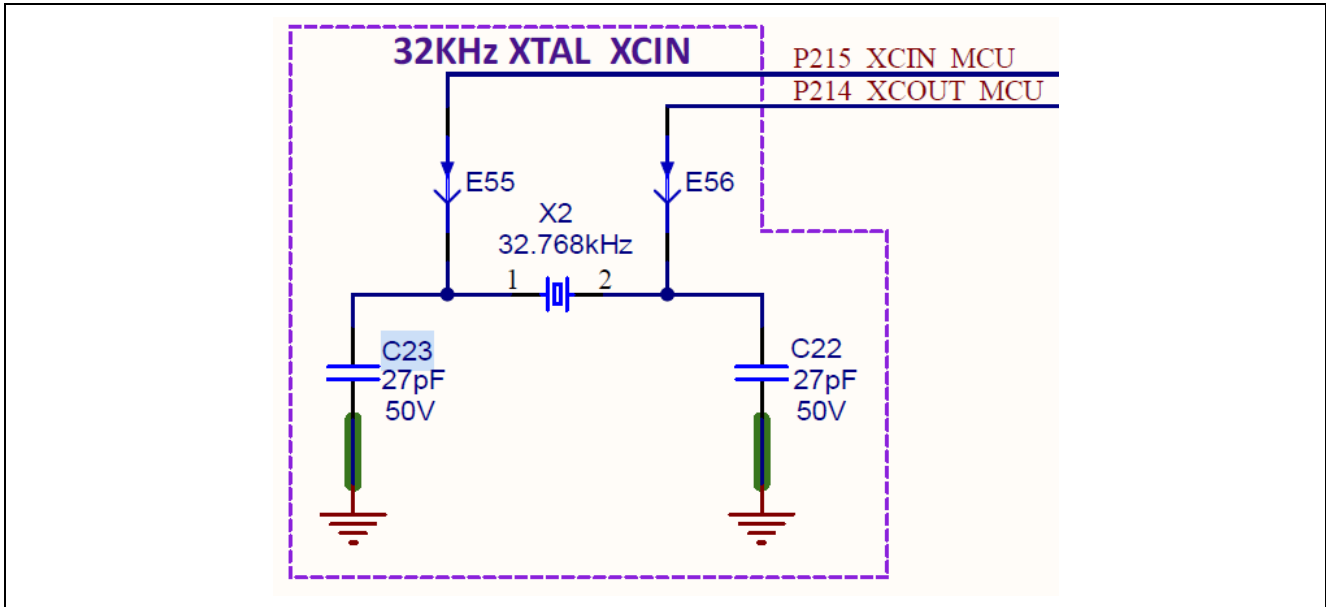

Figure 2. Crystal Oscillator with Incorrect Load Capacitance

2.2.2 Corrective Action

[Affected Kits]

To address this the user can replace the load capacitors, C22/C23, with 8.2pF parts, for example CC0402CRNPO9BN8R2. This value has been tested and found to be appropriate for the device and board configuration.

[Future Kits]

This issue will be corrected in later versions of the kit.

2.2.3 Kits Affected

Version:	1
Serial numbers:	301863 to 302162 and 32855 to 33354

2.3 Incorrectly Calibrated Touch Panel

2.3.1 Description

The Parallel Graphics Expansion Board screen has a resolution of 1024 x 600. The Touch Panel on a small number of kits may be incorrectly calibrated to 800 x 480 resolution. The user may find that touch position does not map to the correct position on the screen.

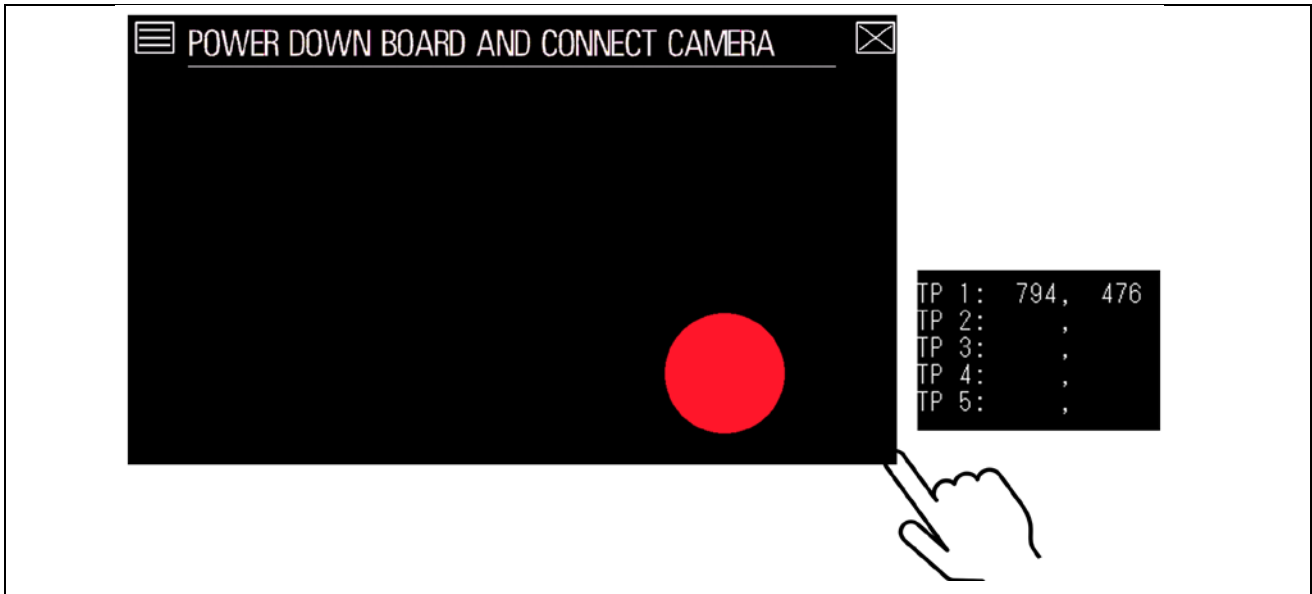

Figure 3. Touch Position Mapping Error

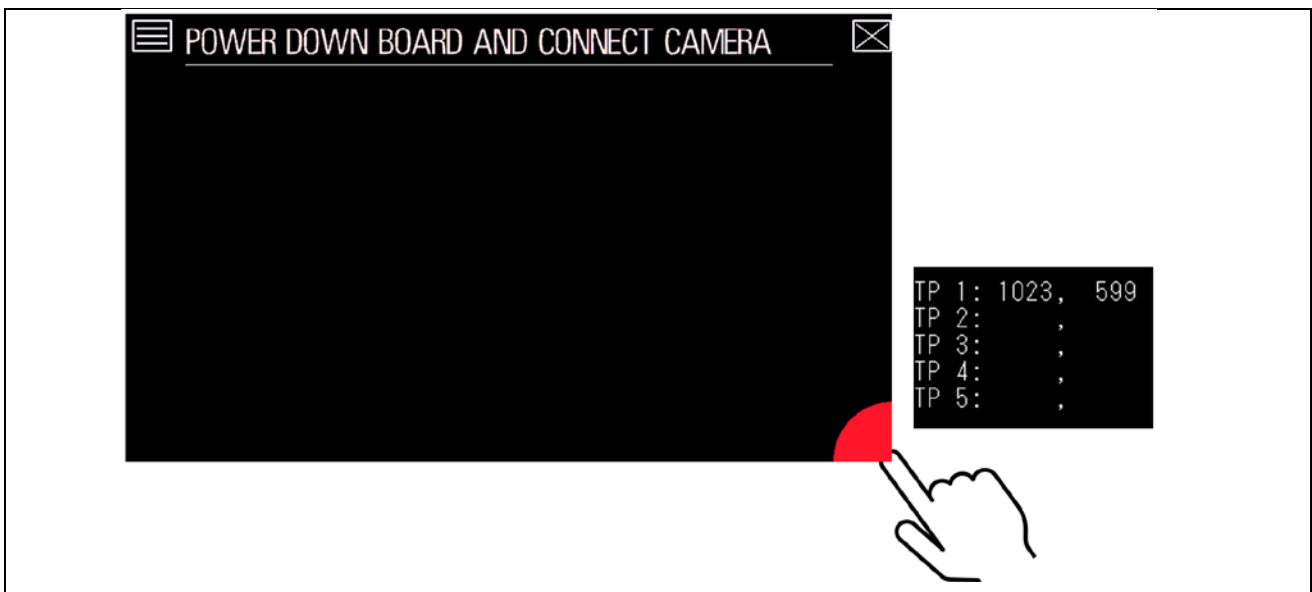

Figure 4. Touch Position Mapping Correct

2.3.2 Corrective Action

This process must only be completed on products using the RTKLCDPAR1S00001BE Display board that demonstrates this issue.

[Affected Kits]

Please follow the steps below to address the issue.

1. Download the associated update package from our website. (r20zz0247eg0200-errata-ek-ra8d2-touchpanel_fix.zip) and extract the contents.
2. Download the latest version of Renesas Flash Programmer (RFP) from our website. (v3.21 or any later version).

3. Start RFP and open the project configuration file from the downloaded and extracted package. (ek-ra8d2_app_lcd_ek_par_1_touchpanel_fix.rpj)
4. Connect the EK-RA8D2 and the APP_LCD_EK_PAR_1 screen.
5. Connect the USB cable between the EK-RA8D2 Debug USB connector (J10) and your computer.
6. Press Start on the RFP dialog.

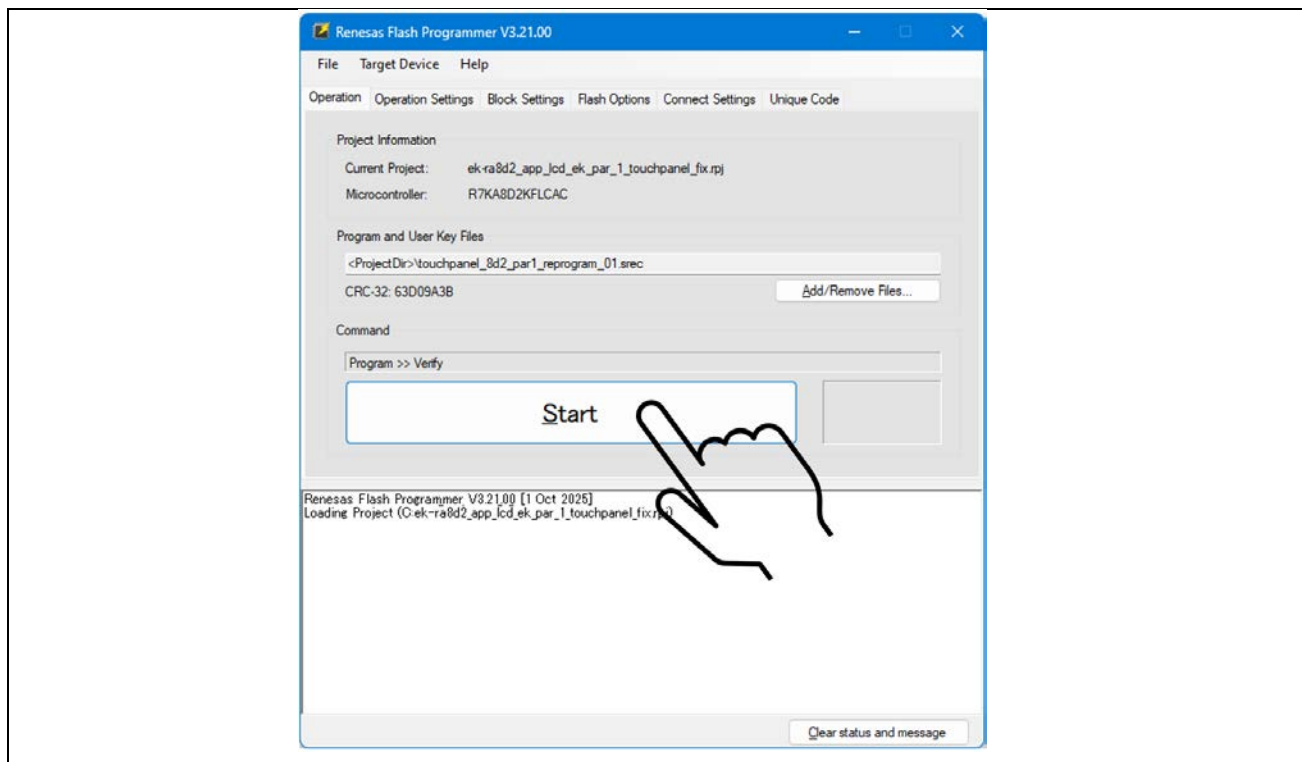

Figure 5. Renesas Flash Programmer Operation

7. The Blue LED will flash several times and then go out. Please wait for about 10 seconds.
8. If the Green LED does not illuminate and the Red LED Flashes constantly – the programming has failed. In this case, please press the reset button on the EK-RA8D2 and try again ensuring the display is connected correctly.
9. When completed successfully, the Green LED will Flash and the Red LED will provide a short flash (to indicate the programming should be checked using the published Quick Start Example Project (QSEP)).
10. The Display Panel has now been re-programmed and will work correctly.
11. In RFP choose the “Target Device” menu and then “Initialize Device” to reset the MCU to a blank state and prevent the code from re-executing.
12. To verify the reprogramming has succeeded, re-program the Quick Start Program by opening the downloaded folder and running the “_run_me_last.bat” file. This will re-program the QSEP project.
13. When complete, the Quick Start Program will run. Press any key to exit the batch file.
14. Choose Option 4 from the serial terminal or the Display Icon from the GUI and verify the circles draw accurately at each touch point.

[Future Kits]

This has been corrected on later versions of the kit.

2.3.3 Kits Affected

Version:	1
Serial numbers:	301863 to 302162 and 32855 to 33354

3. Appendix – Kit Identification

3.1 Kit Version

The kit version is identified on the board above the Renesas RA logo as shown in Figure 6.



Figure 6. Identification of the Kit Version Number on the EK-RA8D2 Board

3.2 Parallel Graphics Expansion Board Version

Please refer to Figure 7 and check the board version highlighted in the red square.

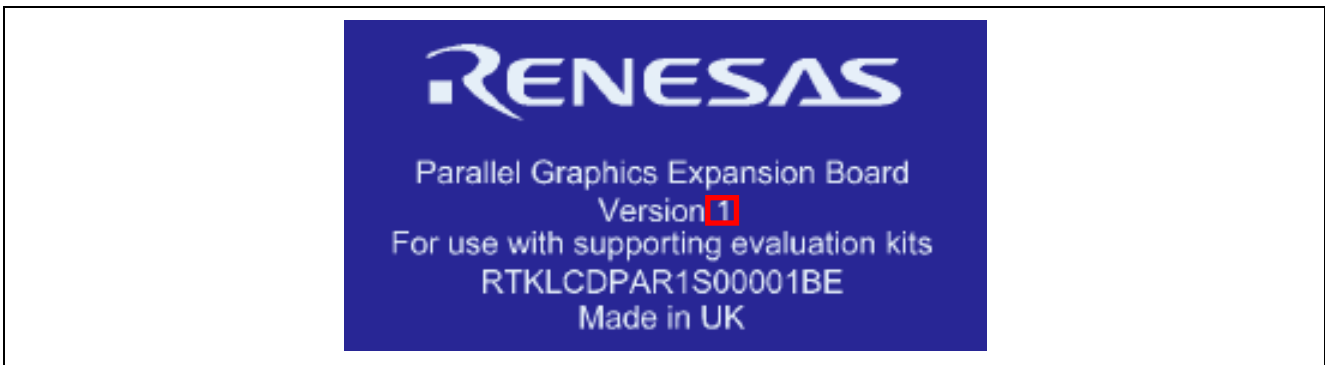

Figure 7. Identification of the Kit Version Number on the Parallel Graphics Expansion Board.

3.3 Serial Number

In addition to the kit version number, the kit serial number is used to uniquely identify a kit.

The serial numbers are located on the bar code stickers on the back/bottom side of EK-RA8D2 and Parallel Graphics Expansion boards. In the example in Figure 8, the serial number is “295672”.

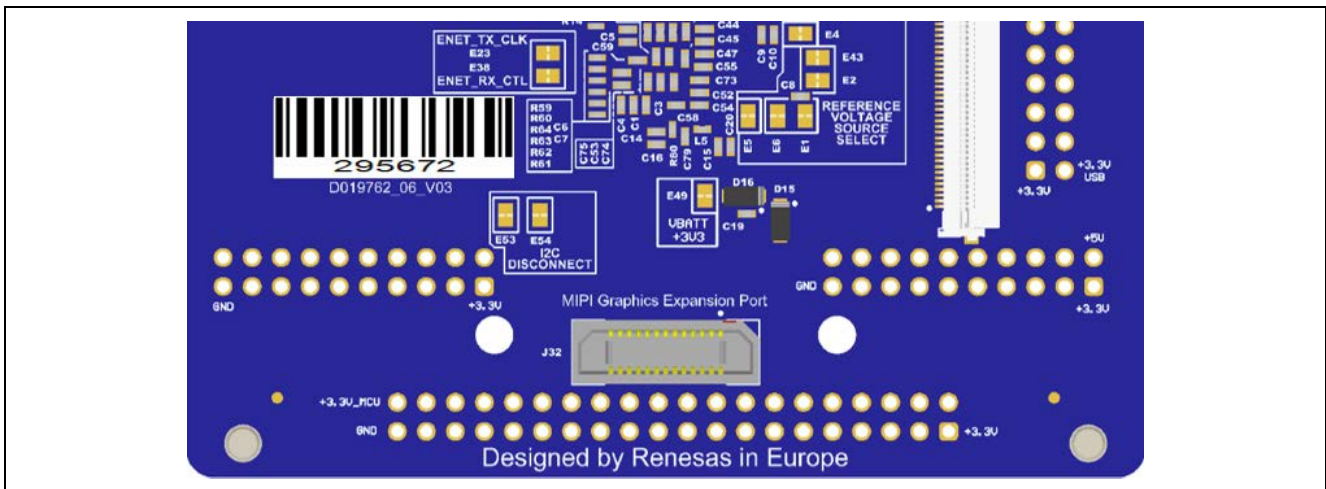

Figure 8. Identification of the Serial Number on the EK-RA8D2 Board

4. Website and Support

Visit the following URLs to learn about the kit and the RA family of microcontrollers, download tools and documentation, and get support.

EK-RA8D2 Resources	renesas.com/ek-ra8d2
RA Kits Information	renesas.com/ra/kits
RA Product Information	renesas.com/ra
RA Product Support Forum	renesas.com/ra/forum
RA Videos	renesas.com/ra/videos
Renesas Support	renesas.com/support
RA Flexible Software Package (FSP)	renesas.com/fsp

Revision History

Rev.	Date	Description	
		Page	Summary
1.00	Oct.24.25	—	Initial release.
2.00	Dec.10.25	5-9	Added section 2.1 and 2.3

EK-RA8D2 v1 – Errata

Publication Date: Dec.10.25

Published by: Renesas Electronics Corporation

EK-RA8D2 v1 – Errata