

To our customers,

---

## Old Company Name in Catalogs and Other Documents

---

On April 1<sup>st</sup>, 2010, NEC Electronics Corporation merged with Renesas Technology Corporation, and Renesas Electronics Corporation took over all the business of both companies. Therefore, although the old company name remains in this document, it is a valid Renesas Electronics document. We appreciate your understanding.

Renesas Electronics website: <http://www.renesas.com>

April 1<sup>st</sup>, 2010  
Renesas Electronics Corporation

Issued by: Renesas Electronics Corporation (<http://www.renesas.com>)

Send any inquiries to <http://www.renesas.com/inquiry>.

## Notice

1. All information included in this document is current as of the date this document is issued. Such information, however, is subject to change without any prior notice. Before purchasing or using any Renesas Electronics products listed herein, please confirm the latest product information with a Renesas Electronics sales office. Also, please pay regular and careful attention to additional and different information to be disclosed by Renesas Electronics such as that disclosed through our website.
2. Renesas Electronics does not assume any liability for infringement of patents, copyrights, or other intellectual property rights of third parties by or arising from the use of Renesas Electronics products or technical information described in this document. No license, express, implied or otherwise, is granted hereby under any patents, copyrights or other intellectual property rights of Renesas Electronics or others.
3. You should not alter, modify, copy, or otherwise misappropriate any Renesas Electronics product, whether in whole or in part.
4. Descriptions of circuits, software and other related information in this document are provided only to illustrate the operation of semiconductor products and application examples. You are fully responsible for the incorporation of these circuits, software, and information in the design of your equipment. Renesas Electronics assumes no responsibility for any losses incurred by you or third parties arising from the use of these circuits, software, or information.
5. When exporting the products or technology described in this document, you should comply with the applicable export control laws and regulations and follow the procedures required by such laws and regulations. You should not use Renesas Electronics products or the technology described in this document for any purpose relating to military applications or use by the military, including but not limited to the development of weapons of mass destruction. Renesas Electronics products and technology may not be used for or incorporated into any products or systems whose manufacture, use, or sale is prohibited under any applicable domestic or foreign laws or regulations.
6. Renesas Electronics has used reasonable care in preparing the information included in this document, but Renesas Electronics does not warrant that such information is error free. Renesas Electronics assumes no liability whatsoever for any damages incurred by you resulting from errors in or omissions from the information included herein.
7. Renesas Electronics products are classified according to the following three quality grades: “Standard”, “High Quality”, and “Specific”. The recommended applications for each Renesas Electronics product depends on the product’s quality grade, as indicated below. You must check the quality grade of each Renesas Electronics product before using it in a particular application. You may not use any Renesas Electronics product for any application categorized as “Specific” without the prior written consent of Renesas Electronics. Further, you may not use any Renesas Electronics product for any application for which it is not intended without the prior written consent of Renesas Electronics. Renesas Electronics shall not be in any way liable for any damages or losses incurred by you or third parties arising from the use of any Renesas Electronics product for an application categorized as “Specific” or for which the product is not intended where you have failed to obtain the prior written consent of Renesas Electronics. The quality grade of each Renesas Electronics product is “Standard” unless otherwise expressly specified in a Renesas Electronics data sheets or data books, etc.
  - “Standard”: Computers; office equipment; communications equipment; test and measurement equipment; audio and visual equipment; home electronic appliances; machine tools; personal electronic equipment; and industrial robots.
  - “High Quality”: Transportation equipment (automobiles, trains, ships, etc.); traffic control systems; anti-disaster systems; anti-crime systems; safety equipment; and medical equipment not specifically designed for life support.
  - “Specific”: Aircraft; aerospace equipment; submersible repeaters; nuclear reactor control systems; medical equipment or systems for life support (e.g. artificial life support devices or systems), surgical implantations, or healthcare intervention (e.g. excision, etc.), and any other applications or purposes that pose a direct threat to human life.
8. You should use the Renesas Electronics products described in this document within the range specified by Renesas Electronics, especially with respect to the maximum rating, operating supply voltage range, movement power voltage range, heat radiation characteristics, installation and other product characteristics. Renesas Electronics shall have no liability for malfunctions or damages arising out of the use of Renesas Electronics products beyond such specified ranges.
9. Although Renesas Electronics endeavors to improve the quality and reliability of its products, semiconductor products have specific characteristics such as the occurrence of failure at a certain rate and malfunctions under certain use conditions. Further, Renesas Electronics products are not subject to radiation resistance design. Please be sure to implement safety measures to guard them against the possibility of physical injury, and injury or damage caused by fire in the event of the failure of a Renesas Electronics product, such as safety design for hardware and software including but not limited to redundancy, fire control and malfunction prevention, appropriate treatment for aging degradation or any other appropriate measures. Because the evaluation of microcomputer software alone is very difficult, please evaluate the safety of the final products or system manufactured by you.
10. Please contact a Renesas Electronics sales office for details as to environmental matters such as the environmental compatibility of each Renesas Electronics product. Please use Renesas Electronics products in compliance with all applicable laws and regulations that regulate the inclusion or use of controlled substances, including without limitation, the EU RoHS Directive. Renesas Electronics assumes no liability for damages or losses occurring as a result of your noncompliance with applicable laws and regulations.
11. This document may not be reproduced or duplicated, in any form, in whole or in part, without prior written consent of Renesas Electronics.
12. Please contact a Renesas Electronics sales office if you have any questions regarding the information contained in this document or Renesas Electronics products, or if you have any other inquiries.

(Note 1) “Renesas Electronics” as used in this document means Renesas Electronics Corporation and also includes its majority-owned subsidiaries.

(Note 2) “Renesas Electronics product(s)” means any product developed or manufactured by or for Renesas Electronics.

## 4-BIT SINGLE-CHIP MICROCOMPUTER

The  $\mu$ PD75028 is a 75X series 4-bit single-chip microcomputer.

The minimum instruction execution time of the  $\mu$ PD75028's CPU is 0.95  $\mu$ s. In addition to this high-speed capability, the chip contains an A/D converter and furnishes high-performance functions such as the serial bus interface (SBI) function that follows the NEC standard format, providing powerful features and high cost performance.

A PROM version,  $\mu$ PD75P036, is also available. The  $\mu$ PD75P036 is suitable for small-scale production or experimental production in system development.

**Detailed functional description for the  $\mu$ PD75028 is shown in the following user's manual. Be sure to read it when starting design.**

$\mu$ PD75028 User's Manual: IEU-

### FEATURES

- Fast execution time (@4.19 MHz)
  - High speed cycle: 0.95  $\mu$ s
  - Low-voltage cycles: 1.91  $\mu$ s and 15.3  $\mu$ s
- Power-reducing operation
  - With system clock operating at 32.768 kHz (execution time: 122  $\mu$ s)
- A/D converter
  - 8-channel, 8-bit
- Low-voltage operation possible ( $V_{DD} = 2.7$  to 6.0 V)
- Four timers
  - One of them can be used as PWM output, 16-bit counter for an integrating A/D converter, etc.
- NEC standard serial bus interface
  - SBI mode
- Very low-power clock operation: 5  $\mu$ A TYP. (at 3 V in HALT mode)

### APPLICATIONS

Electric home appliances, air conditioners, cameras, and electronic measuring instruments

### ORDERING INFORMATION

Part number	Package	Quality grade
$\mu$ PD75028CW-xxx	64-pin plastic shrink DIP (750 mil)	Standard
$\mu$ PD75028GC-xxx-AB8	64-pin plastic QFP ( $\square$ 14 mm)	Standard

**Remark** xxx is a mask ROM code number.

Please refer to "Quality grade on NEC Semiconductor Devices" (Document number IEI-1209) published by NEC Corporation to know the specification of quality grade on the devices and its recommended applications.

The information in this document is subject to change without notice.

**FUNCTION TABLE**

Item		Function		
Instruction execution time		<ul style="list-style-type: none"> <li>• 0.95, 1.91, 15.3 μs (at main system clock of 4.19 MHz)</li> <li>• 122 μs (at subsystem clock of 32.768 kHz)</li> </ul>		
Internal memory	ROM	8064 × 8 bits		
	RAM	512 × 4 bits		
General registers		<ul style="list-style-type: none"> <li>• 8: in 4-bit mode</li> <li>• 4: in 8-bit mode</li> </ul>		
I/O ports	48	12	CMOS input pins	Selectable by software Of these, 27 can have pull-up resistors, and 4 can have pull-down resistors.
		24	CMOS I/O pins (Of these, four can directly drive LEDs.)	
		12	N-ch open-drain I/O pins (Of these, eight can directly drive LEDs.)	Break-down voltage: 10 V Mask-option pull-up resistors are available.
Timer	4 channels	<ul style="list-style-type: none"> <li>• Timer/event counter</li> <li>• Basic interval timer : applicable to Watchdog timer</li> <li>• Clock timer : Capable of buzzer output</li> <li>• Multi-function timer</li> </ul>		
Serial interface		<ul style="list-style-type: none"> <li>• 3-wire serial I/O mode</li> <li>• 2-wire serial I/O mode</li> <li>• SBI mode</li> </ul>		
A/D converter		8 bits (resolution) × 8 channels (successive approximation) Operable at low voltage: V <sub>DD</sub> = 2.7 to 6.0 V		
Bit sequential buffer		16 bits		
Clock output function		Φ, f <sub>x</sub> /2 <sup>3</sup> , f <sub>x</sub> /2 <sup>4</sup> , f <sub>x</sub> /2 <sup>6</sup>		
Vectored interrupts		External: 3, Internal: 4		
Test input		External: 1, Internal: 1		
System clock oscillator		<ul style="list-style-type: none"> <li>• Ceramic/crystal oscillator for main system clock</li> <li>• Crystal oscillator for subsystem clock</li> </ul>		
Standby function		STOP/HALT mode		
Operating ambient temperature		-40 °C +70 °C		
Operating power supply voltage		2.7 to 6.0 V		
Package		<ul style="list-style-type: none"> <li>• 64-pin plastic shrink DIP (750 mil)</li> <li>• 64-pin plastic QFP (□ 14 mm)</li> </ul>		

## CONTENTS

1. PIN CONFIGURATION (TOP VIEW) ...	4	
2. BLOCK DIAGRAM ...	6	
3. PIN FUNCTIONS ...	7	
3.1 PORT PINS ...	7	
3.2 NON-PORT PINS ...	9	
3.3 PIN INPUT/OUTPUT CIRCUITS ...	11	
3.4 MASK OPTION SELECTION ...	13	
3.5 HANDLING UNUSED PINS ...	14	★
4. MEMORY MAPPING ...	15	
5. PERIPHERAL HARDWARE FUNCTIONS ...	18	
5.1 PORTS ...	18	
5.2 CLOCK GENERATOR CIRCUIT ...	19	
5.3 CLOCK OUTPUT CIRCUIT ...	20	
5.4 BASIC INTERVAL TIMER ...	21	
5.5 CLOCK TIMER ...	22	
5.6 TIMER/EVENT COUNTER ...	23	
5.7 SERIAL INTERFACE ...	25	
5.8 A/D CONVERTER ...	27	
5.9 MULTI-FUNCTION TIMER (MFT) ...	28	
5.10 BIT SEQUENTIAL BUFFER: 16 BITS ...	30	
6. INTERRUPT FUNCTIONS ...	31	
7. STANDBY FUNCTION ...	33	
8. RESET OPERATION ...	34	
9. INSTRUCTION SET ...	36	
10. ELECTRICAL SPECIFICATIONS ...	43	
11. CHARACTERISTIC CURVES (FOR REFERENCE ONLY) ...	57	★
12. PACKAGE DRAWINGS ...	63	
13. RECOMMENDED SOLDERING CONDITIONS ...	65	
APPENDIX A. DEVELOPMENT TOOLS ...	66	
APPENDIX B. RELATED DOCUMENTS ...	67	★

1. PIN CONFIGURATION (TOP VIEW)

- 64-pin plastic shrink DIP (750 mil)

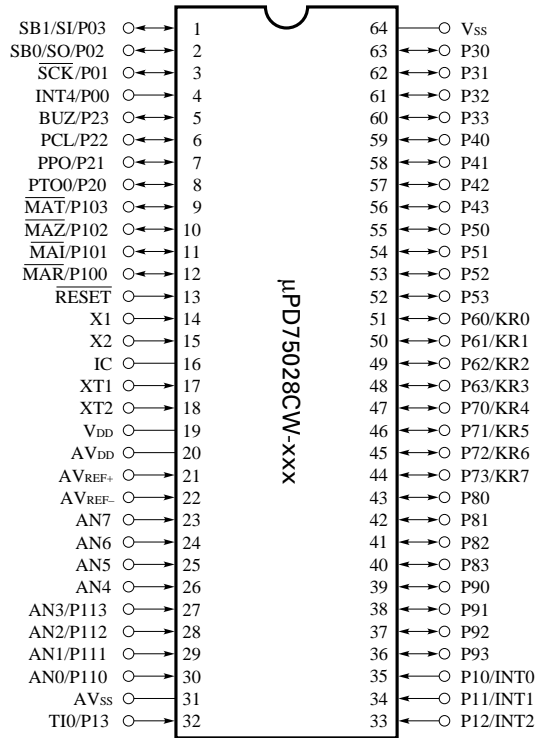

- 64-pin plastic QFP (□ 14 mm)

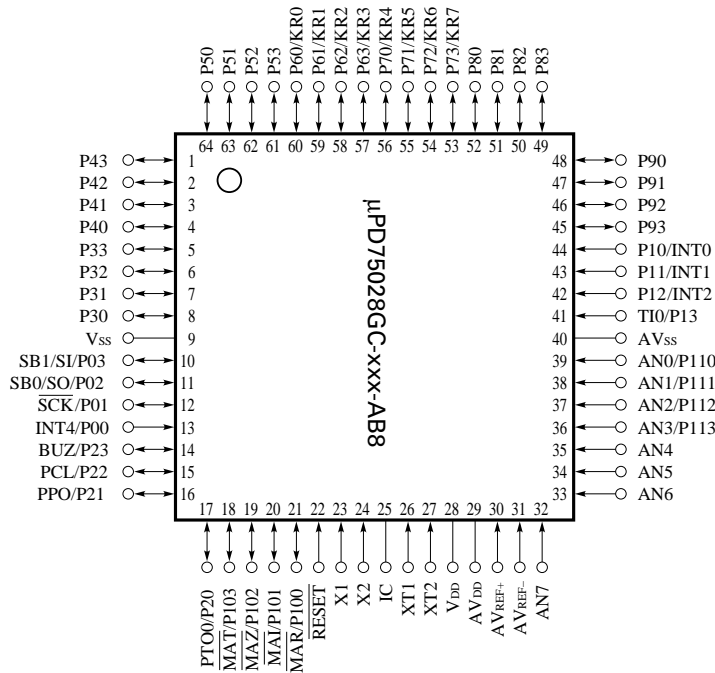

IC: Internally Connected (should be connected directly to VDD)

**PIN NAMES**

- P00 - 03 : Port 0
- P10 - 13 : Port 1
- P20 - 23 : Port 2
- P30 - 33 : Port 3
- P40 - 43 : Port 4
- P50 - 53 : Port 5
- P60 - 63 : Port 6
- P70 - 73 : Port 7
- P80 - 83 : Port 8
- P90 - 93 : Port 9
- P100 - 103 : Port 10
- P110 - 113 : Port 11
- KR0 - 7 : Key Return
- $\overline{\text{SCK}}$  : Serial Clock
- SI : Serial Input
- SO : Serial Output
- SB0, 1 : Serial Bus 0, 1
- $\overline{\text{RESET}}$  : Reset Input
- TI0 : Timer Input 0
- PTO0 : Programmable Timer Output 0
- BUZ : Buzzer Clock
- PCL : Programmable Clock
- INT0, 1, 4 : External Vectored Interrupt 0, 1, 4
- INT2 : External Test Input 2
- X1, 2 : Main System Clock Oscillation 1, 2
- XT1, 2 : Subsystem Clock Oscillation 1, 2
- $\overline{\text{MAR}}$  : Reference Integration Control
- $\overline{\text{MAI}}$  : Integration Control
- $\overline{\text{MAZ}}$  : Autozero Control
- $\overline{\text{MAT}}$  : External Compare Timing Input
- PPO : Programmable Pulse Output ... MFT timer mode
- AN0 - 7 : Analog Input 0 - 7
- AVREF+ : Analog Reference (+)
- AVREF- : Analog Reference (-)
- AVDD : Analog VDD
- AVSS : Analog VSS
- VDD : Positive Power Supply
- VSS : Ground

} MFT A/D mode

**Remark** MFT: Multi-Function Timer

**Phase-out/Discontinued**

**2. BLOCK DIAGRAM**

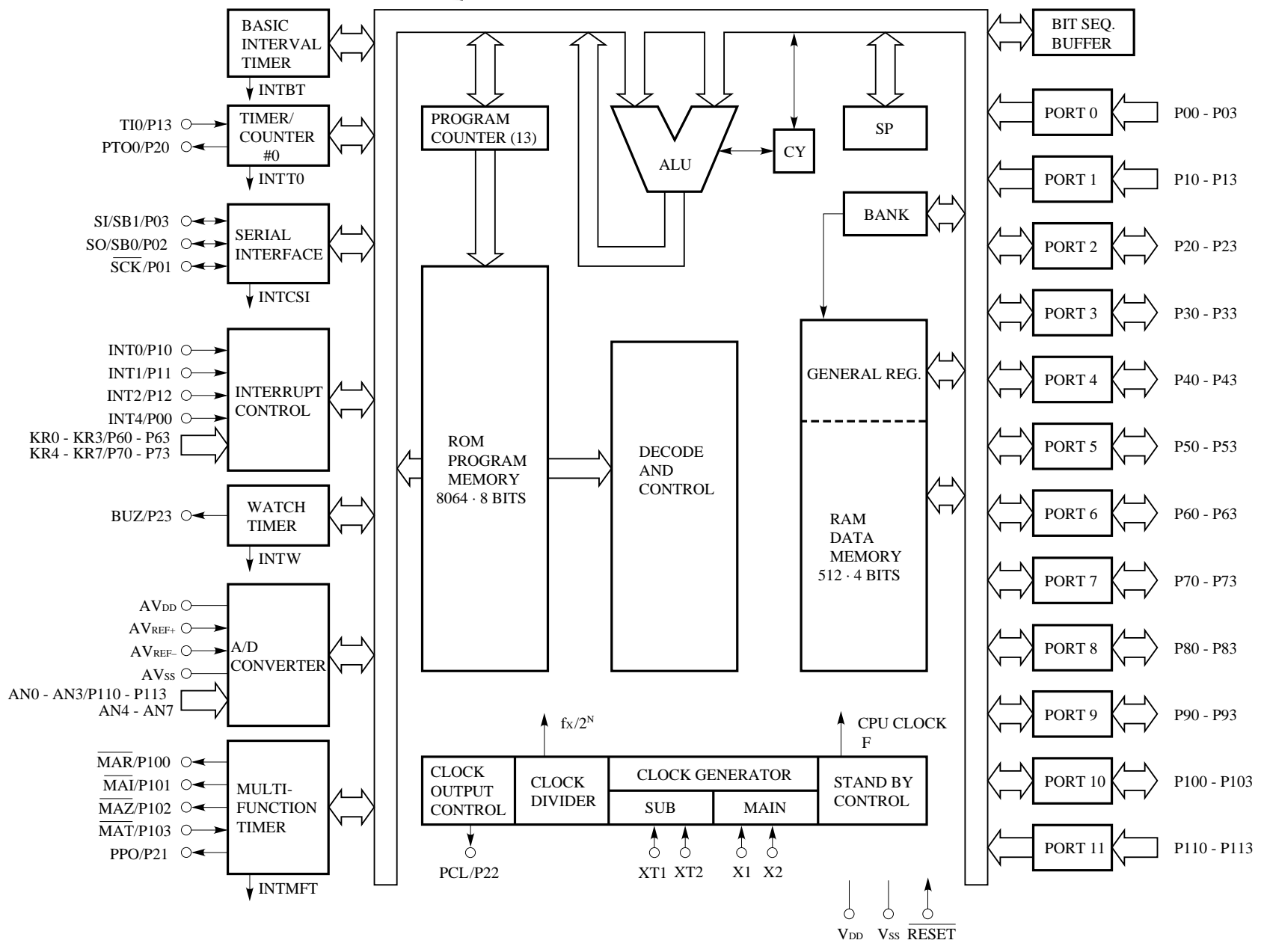



3. PIN FUNCTIONS

3.1 PORT PINS (1/2)

Pin name	Input/output	Shared pin	Function	8-bit I/O	When reset	I/O circuit type <sup>Note 1</sup>
P00	Input	INT4	4-bit input port (PORT0). For P01 - P03, pull-up resistors can be provided by software in units of 3 bits.	×	Input	ⓑ
P01	I/O	$\overline{\text{SCK}}$				Ⓕ-A
P02	I/O	SO/SB0				Ⓕ-B
P03	I/O	SI/SB1				Ⓜ-C
P10	Input	INT0	4-bit input port (PORT1). Pull-up resistors can be provided by software in units of 4 bits.	×	Input	ⓑ-C
P11		INT1				
P12		INT2				
P13		TI0				
P20	I/O	PTO0	4-bit I/O port (PORT2). Pull-up resistors can be provided by software in units of 4 bits.	×	Input	E-B
P21		PPO				
P22		PCL				
P23		BUZ				
P30 <sup>Note 2</sup>	I/O	-	Programmable 4-bit I/O port (PORT3). I/O can be specified bit by bit. Pull-up resistors can be provided by software in units of 4 bits.	×	Input	E-B
P31 <sup>Note 2</sup>		-				
P32 <sup>Note 2</sup>		-				
P33 <sup>Note 2</sup>		-				
P40 - P43 <sup>Note 2</sup>	I/O	-	N-ch open-drain 4-bit I/O port (PORT4). A pull-up resistor can be provided for each bit (mask option). Withstand voltage is 10 V in open-drain mode.	○	High level (when pull-up resistors are provided) or high impedance	M
P50 - P53 <sup>Note 2</sup>					N-ch open-drain 4-bit I/O port (PORT5). A pull-up resistor can be provided for each bit (mask option). Withstand voltage is 10 V in open-drain mode.	High level (when pull-up resistors are provided) or high impedance

- Note 1.** The circle (○) indicates the Schmitt trigger input.  
**2.** Can directly drive LEDs.

3.1 PORT PINS (2/2)

Pin name	Input/output	Shared pin	Function	8-bit I/O	When reset	I/O circuit type <sup>Note</sup>	
P60	I/O	KR0	Programmable 4-bit I/O port (PORT6). I/O can be specified bit by bit. Pull-up resistors can be provided by software in units of 4 bits.	○	Input	Ⓔ-A	
P61		KR1					
P62		KR2					
P63		KR3					
P70	I/O	KR4	4-bit I/O port (PORT 7). A pull-up resistor can be provided by software in units of 4 bits		×	Input	Ⓔ-A
P71		KR5					
P72		KR6					
P73		KR7					
P80 - P83	I/O	-	4-bit I/O port (PORT 8). A pull-up resistor can be provided by software in units of 4 bits.	×		Input	E-B
P90 - P93	I/O	-	4-bit I/O port (PORT 9). A pull-up resistor can be provided by software in units of 4 bits.			Input	E-D
P100	I/O	$\overline{\text{MAR}}$	N-ch open drain 4-bit I/O port (PORT 10). A pull-up resistor can be provided for each bit (mask option). Withstand voltage is 10 V in open-drain mode.	×		High level (when pull-up resistors are provided) or high impedance	M
P101		$\overline{\text{MAI}}$					
P102		$\overline{\text{MAZ}}$					
P103		$\overline{\text{MAT}}$					
P110	Input	AN0	4-bit input port (PORT11).			Input	Y-A
P111		AN1					
P112		AN2					
P113		AN3					

**Note** The circle (○) indicates the Schmitt trigger input.

3.2 NON-PORT PINS (1/2)

Pin name	Input/output	Shared pin	Function		When reset	I/O circuit type <sup>Note 1</sup>
T10	Input	P13	Input for receiving external event pulse signal for timer/event counter		-	ⓑ-C
PTO0	I/O	P20	Timer/event counter output		Input	E-B
PCL	I/O	P22	Clock output		Input	E-B
BUZ	I/O	P23	Output for arbitrary frequency output (for buzzer output or system clock trimming)		Input	E-B
$\overline{\text{SCK}}$	I/O	P01	Serial clock I/O		Input	Ⓕ-A
SO/SB0	I/O	P02	Serial data output Serial bus I/O		Input	Ⓕ-B
SI/SB1	I/O	P03	Serial data input Serial bus I/O		Input	Ⓜ-C
INT4	Input	P00	Edge detection vectored interrupt input (either rising edge or falling edge detection)		-	ⓑ
INT0	Input	P10	Edge detection vectored interrupt input (detection edge selectable)	Clock synchronous	-	ⓑ-C
INT1		P11		Asynchronous		
INT2	Input	P12	Edge detection testable input (rising edge detection)	Asynchronous	-	ⓑ-C
KR0 - KR3	I/O	P60 - P63	Parallel falling edge detection testable input		Input	Ⓕ-A
KR4 - KR7	I/O	P70 - P73	Parallel falling edge detection testable input		Input	Ⓕ-A
$\overline{\text{MAR}}$	I/O	P100	In MFT integrating A/D converter mode	Reverse integration signal output	<b>Note 2</b>	M
$\overline{\text{MAI}}$	I/O	P101		Integration signal output	<b>Note 2</b>	M
$\overline{\text{MAZ}}$	I/O	P102		Auto-zero signal output	<b>Note 2</b>	M
$\overline{\text{MAT}}$	I/O	P103		Comparator input	<b>Note 2</b>	M
PPO	I/O	P21	In MFT timer mode	Timer pulse output	Input	E-B
AN0 - AN3	Input	P110 - P113	For A/D converter only	8-bit analog input	Input	Y-A
AN4 - AN7		-		-	-	-
AV <sub>REF+</sub>	Input	-		Reference voltage input (AV <sub>DD</sub> side)	-	Z-A
AV <sub>REF-</sub>	Input	-		Reference voltage input (AV <sub>SS</sub> side)	-	Z-A
AV <sub>DD</sub>	-	-		Positive power supply	-	-
AV <sub>SS</sub>	-	-		Ground	-	-

**Note 1.** The circle (○) indicates the Schmitt trigger input.

2. High level (in use of on-chip pull-up resistor) or high impedance

**Remark** MFT: Multi-Function Timer

3.2 NON-PORT PINS (2/2)

Pin name	Input/output	Shared pin	Function	When reset	I/O circuit type <sup>Note</sup>
X1, X2	Input	–	Crystal/ceramic connection for main system clock generation. When external clock signal is used, it is applied to X1, and its reverse phase signal is applied to X2.	–	–
XT1, XT2	Input	–	Crystal connection for subsystem clock generation. When external clock signal is used, it is applied to XT1, and its reverse phase signal is applied to XT2, XT1 can be used as a 1-bit input (test).	–	–
$\overline{\text{RESET}}$	Input	–	System reset input	–	ⓑ
IC	–	–	Internally connected. (To be connected to V <sub>DD</sub> )	–	–
V <sub>DD</sub>	–	–	Positive power supply	–	–
V <sub>SS</sub>	–	–	GND potential	–	–

**Note** The circle (○) indicates the Schmitt trigger input.

**3.3 PIN INPUT/OUTPUT CIRCUITS**

The input/output circuit of each  $\mu$ PD75028 pin is shown below in a simplified manner.

(1/3)

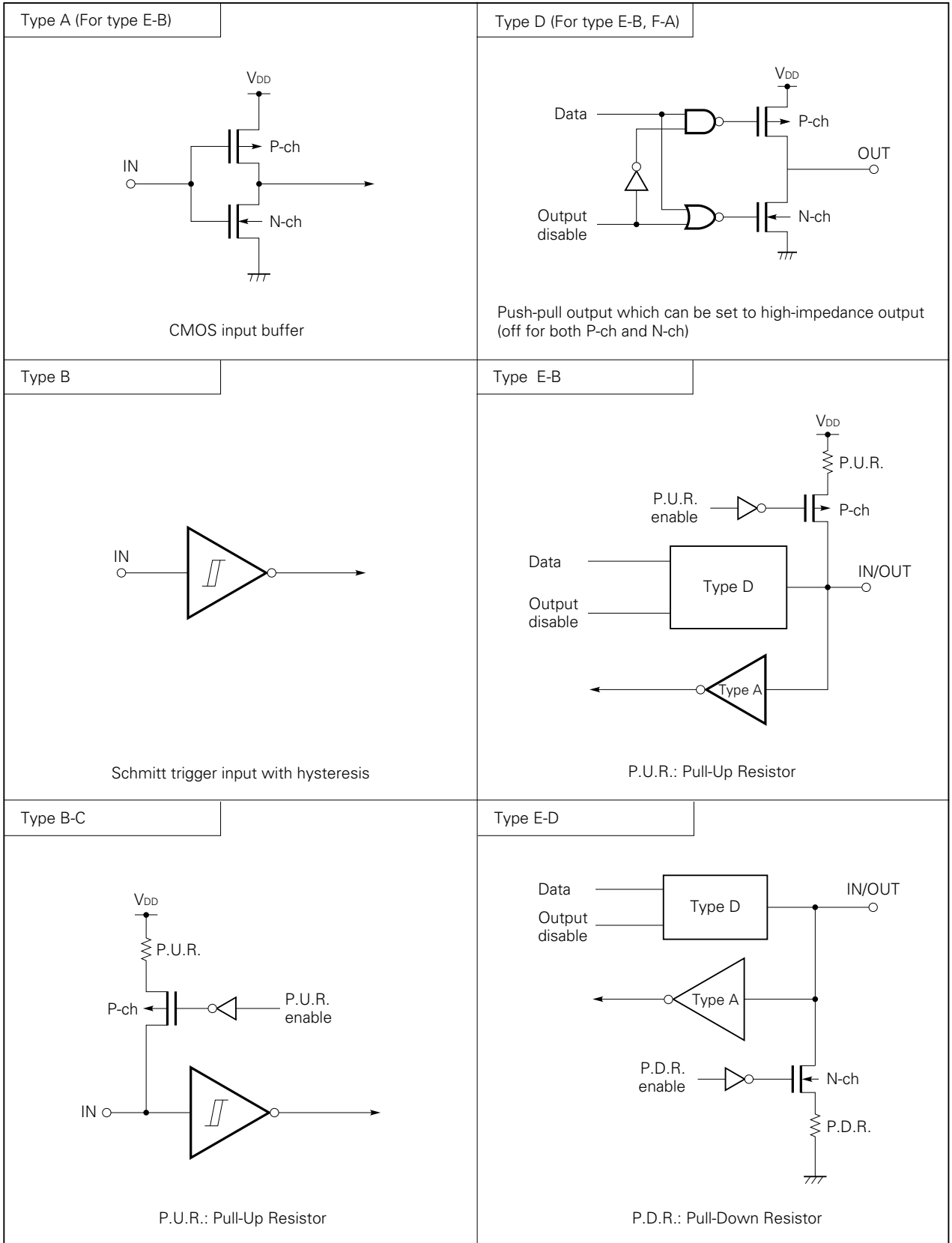

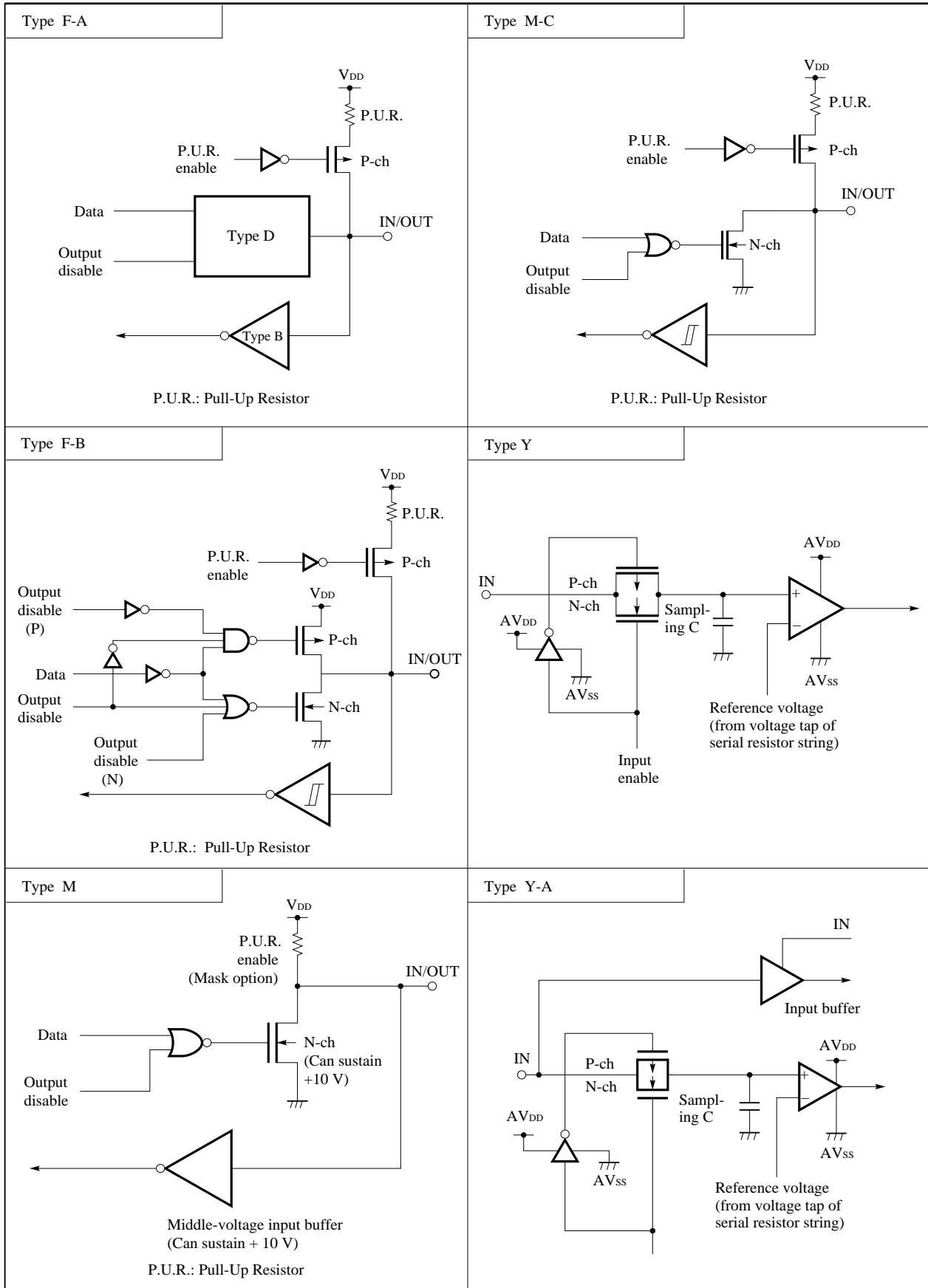

(3/3)

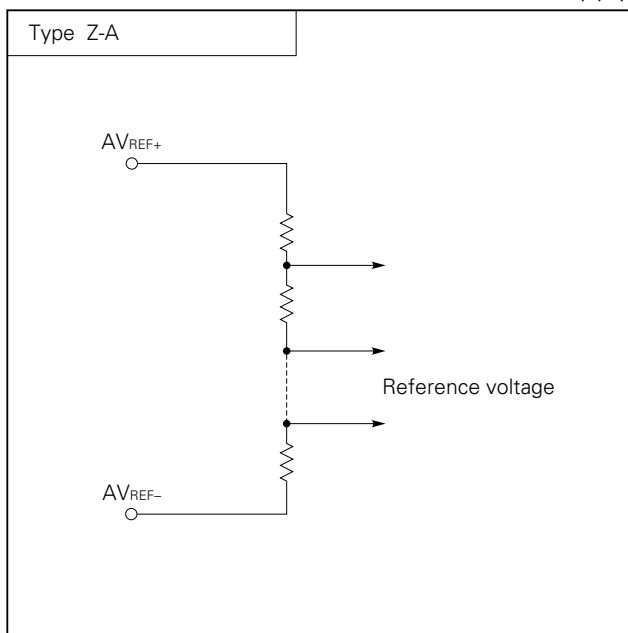

**3.4 MASK OPTION SELECTION**

The following mask options are available for selection for each pin.

Pin name	Mask option	
P40 - P43, P50 - P53, P100 - P103	① Pull-up resistor provided (specifiable bit by bit)	② Pull-up resistor not provided (specifiable bit by bit)
XT1, XT2	① Feedback resistor provided (if a subsystem clock is used)	② Feedback resistor not provided (if a subsystem clock is not used)

## ★ 3.5 HANDLING UNUSED PINS

Table 3-1 Handling Unused Pins

Pin name	Recommended connection	
P00/INT4	Connected to V <sub>SS</sub>	
P01/ $\overline{\text{SCK}}$	Connected to V <sub>SS</sub> or V <sub>DD</sub>	
P02/SO/SB0		
P03/SI/SB1		
P10/INT0-P12/INT2	Connected to V <sub>SS</sub>	
P13/TI0		
P20/PTO0	Input mode : Connected to V <sub>SS</sub> or V <sub>DD</sub> Output mode : Left unconnected	
P21		
P22/PCL		
P23/BUZ		
P30-P33		
P40-P43		
P50-P53		
P60-P63		
P70-P73		
P80-P83		
P90-P93		
P100-P103		
P110/AN0-P113/AN3		Connected to V <sub>SS</sub> or V <sub>DD</sub>
AN4-AN7		
AV <sub>REF+</sub>	Connected to V <sub>SS</sub>	
AV <sub>REF-</sub>		
AV <sub>SS</sub>		
AV <sub>DD</sub>	Connected to V <sub>DD</sub>	
XT1	Connected to V <sub>SS</sub> or V <sub>DD</sub>	
XT2	Left unconnected	
IC	Directly connected to V <sub>DD</sub>	



#### 4. MEMORY MAPPING

- Program memory (ROM) : 8064 X 8 bits (0000H-1F7FH)
  - 0000H-0001H : A vector table where a program start address is written upon resetting.
  - 0002H-000DH : A vector table where a program start address is written upon interruption.
  - 0020H-007FH : A table area referenced by GETI instruction.
- Data memory
  - Data area : 512 X 4 bits (000H-1FFH)
  - Peripheral hardware area : 128 X 4 bits (F80H-FFFH)

Fig. 4-1 Program Memory Map

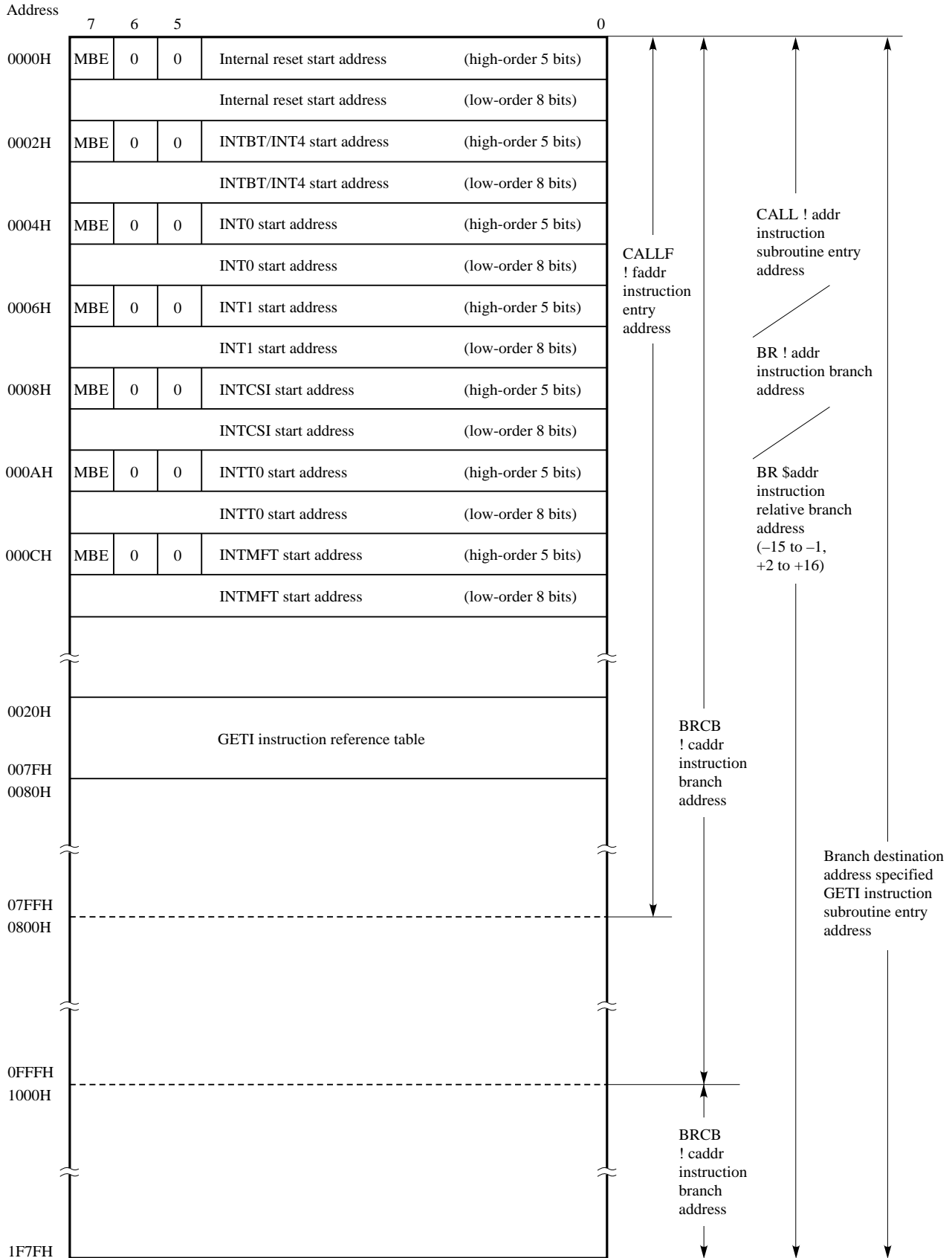
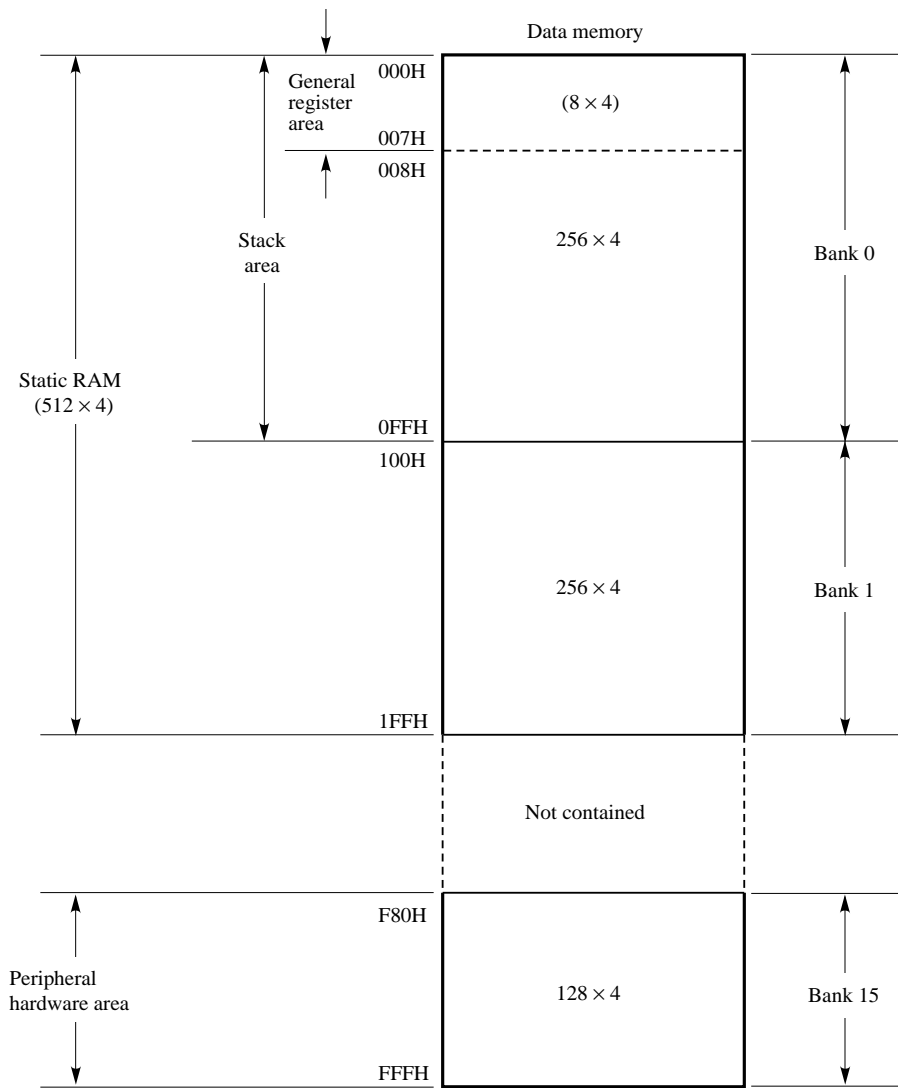

Fig. 4-2 Data Memory Map



**5. PERIPHERAL HARDWARE FUNCTIONS**

**5.1 PORTS**

There are the following three types of ports:

- CMOS input ports (port 0, 1, 11) : 12
  - CMOS I/O ports (port 2, 3, 6, 7, 8, 9) : 24
  - N-ch open-drain I/O ports (port 4, 5, 10) : 12
- 
- Total 48

**Table 5-1 Port Functions**

Port name	Function	Operation/features	Remarks
PORT0 PORT1	4-bit Input	Can be read or tested regardless of the operation mode of the shared pin.	Shared with the SO/SB0, SI/SB1, $\overline{SCK}$ , INT0-2, 4, and T10 pins.
PORT2 PORT7	4-bit I/O	Can be specified for input/output in 4-bit units. Port 6 and 7 can be paired to input/output data in 8-bit units.	Port 2 pins are also used as PTO0, PPO, PCL, and BUZ. Port 7 pins are also used as KR4-7.
PORT3 <sup>Note</sup> PORT6		Can be specified for input/output in bit units.	Port 6 pins are also used as KR0 - 3.
PORT4 <sup>Note</sup> PORT5 <sup>Note</sup> PORT10		4-bit I/O (N-ch open drain, can sustain 10 V)	Can be specified for input/output in 4-bit units. Port 4 and 5 can be paired to input/output data in 8-bit units.
PORT8 PORT9	4-bit I/O	Can be specified for input/output in 4-bit units.	
PORT11	4-bit Input	4-bit port dedicated to input	Port 11 is shared with pins AN0 to AN3.

**Note** Can directly drive LEDs.

**5.2 CLOCK GENERATOR CIRCUIT**

The operation of the clock generator is determined by the processor clock control register (PCC) and the system clock control register (SCC).

Two types of clock frequencies are available: main system clock and subsystem clock frequencies.

It is possible to vary the instruction execution time.

- 0.95  $\mu$ s, 1.91  $\mu$ s, 15.3  $\mu$ s (at main system clock of 4.19 MHz)
- 122  $\mu$ s (at subsystem clock of 32.768 kHz)

**Fig. 5-1 Clock Generator Block Diagram**

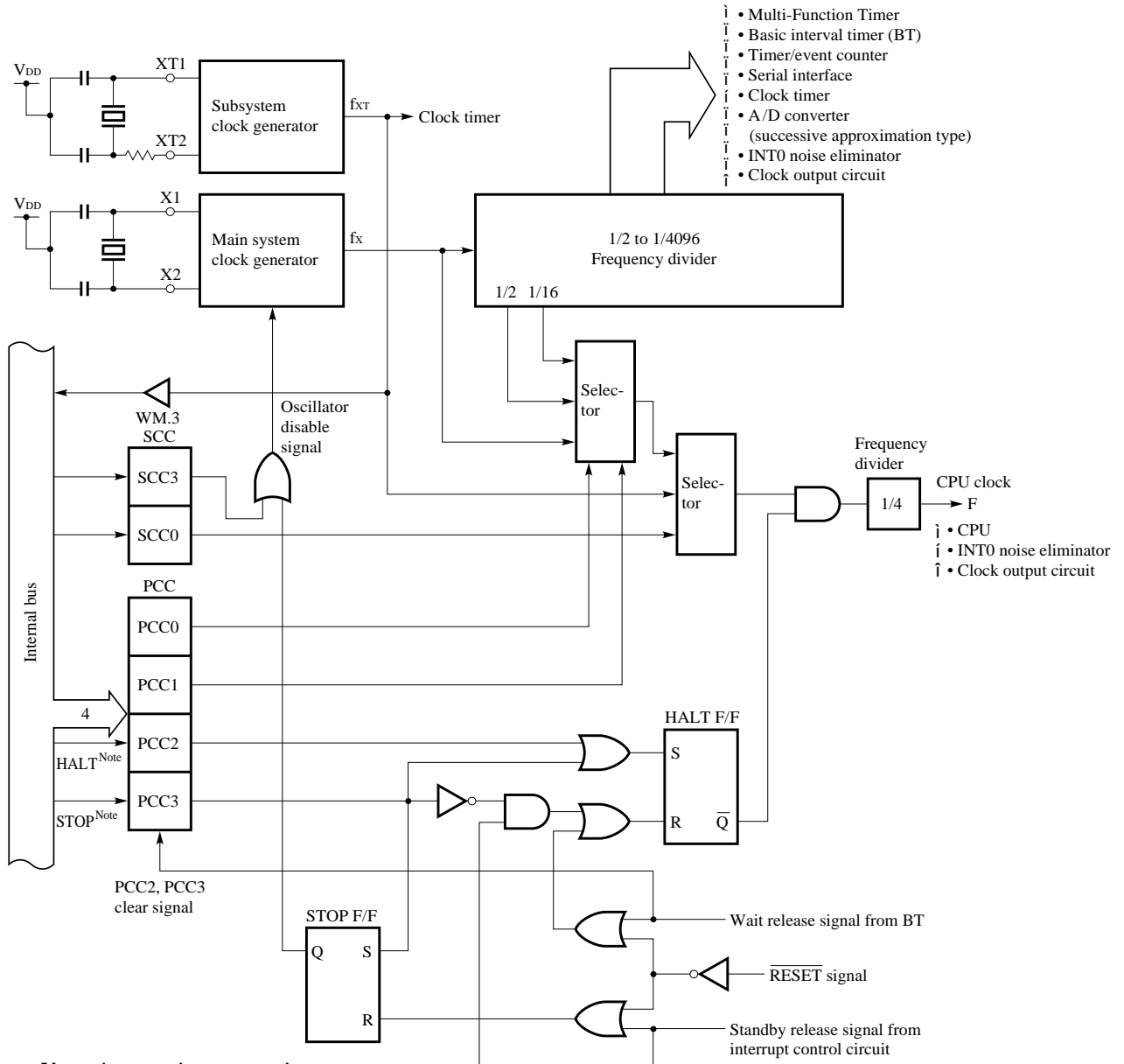

**Note** Instruction execution

- Remarks**
1.  $f_x$  = Main system clock frequency
  2.  $f_{XT}$  = Subsystem clock frequency
  3. PCC: Processor clock control register
  4. SCC: System clock control register
  5. One clock cycle of  $\Phi$  ( $t_{CY}$ ) is equal to 1 machine cycle of an instruction. For the  $t_{CY}$ , refer to **10. ELECTRICAL SPECIFICATIONS AC characteristics.**

**5.3 CLOCK OUTPUT CIRCUIT**

The clock output circuit outputs clock pulses through the P22/PCL pin. It is used to output clock pulses to a remote control output or peripheral LSI.

- Clock output (PCL):  $\Phi$ , 524 kHz, 262 kHz, 65.5 kHz (at  $f_x = 4.19$  MHz)

The configuration of the clock output circuit is shown below.

**Fig. 5-2 Clock Output Circuit Configuration**

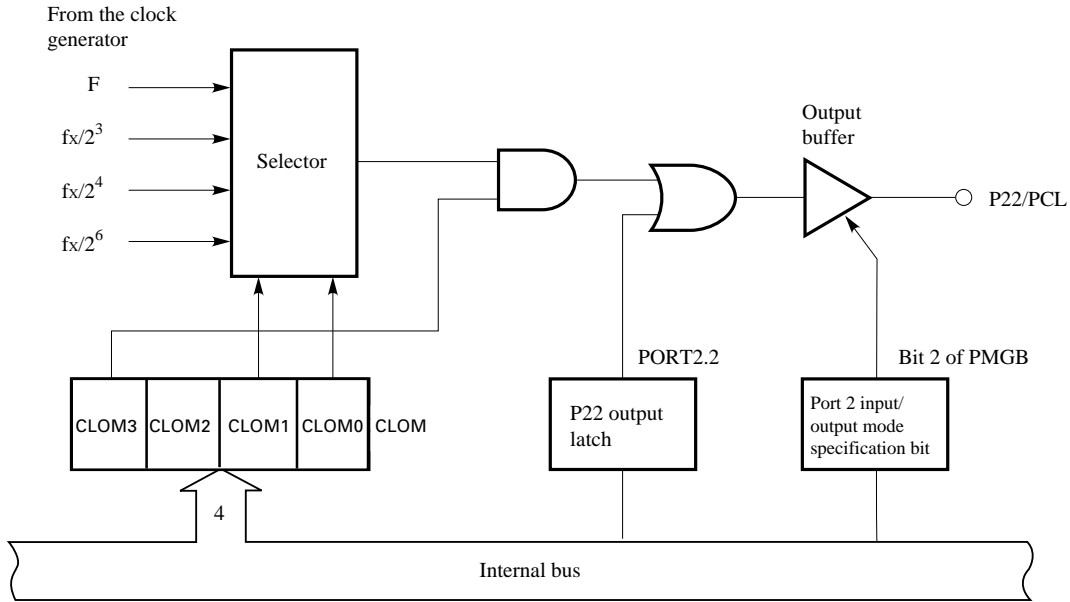

**Remark** Measures are taken to prevent outputting a narrow pulse when selecting clock output enable/disable.

**5.4 BASIC INTERVAL TIMER**

The basic interval timer has these functions:

- Interval timer operation which generates a reference timer interrupt
- Watchdog timer application which detects a program runaway
- Selection of wait time for releasing the standby mode and counting the wait time
- Reading out the count value

**Fig. 5-3 Basic Interval Timer Configuration**

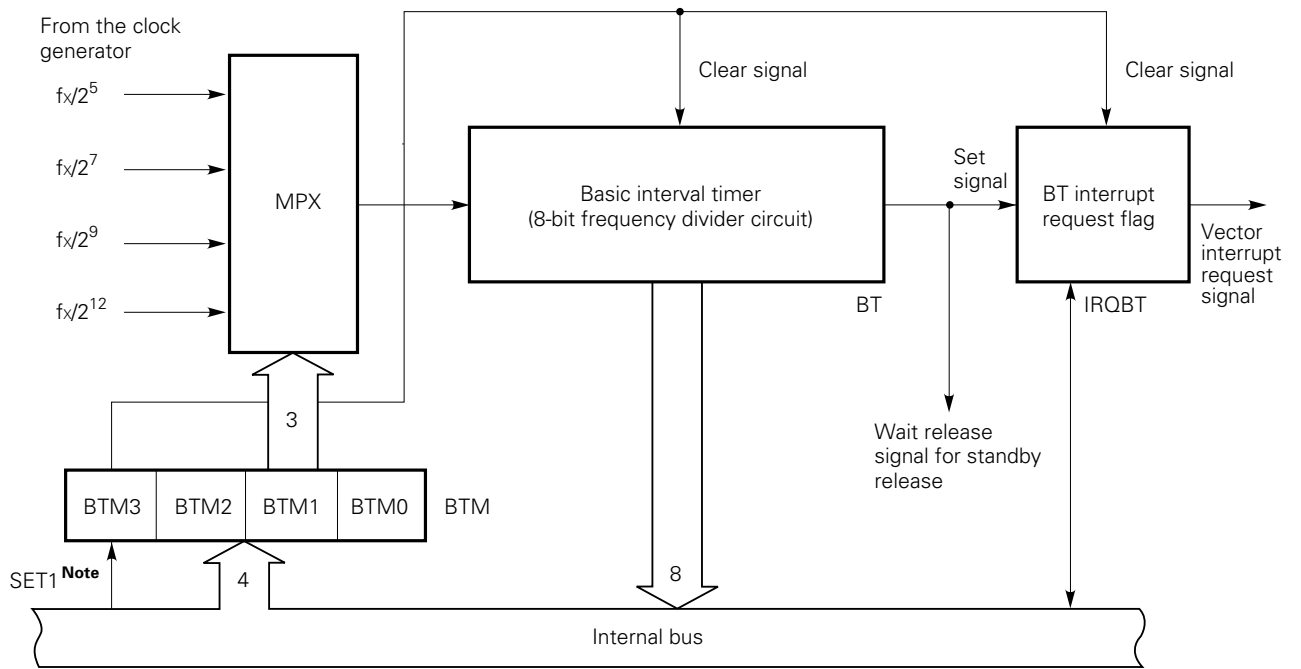

**Note** Instruction execution

**5.5 CLOCK TIMER**

The μPD75028 has a built-in 1-ch clock timer. The clock timer has the following functions:

- Sets the test flag (IRQW) with a 0.5-sec interval. The standby mode can be released by IRQW.
- The 0.5-second interval can be generated from either the main system clock or subsystem clock.
- The time interval can be made 128 times faster (3.91 ms) by selecting the fast mode. This is convenient for program debugging, testing, etc.
- Any of the frequencies 2.048 kHz, 4.096 kHz, and 32.768 kHz can be output to the P23/BUZ pin. This can be used for beep and system clock frequency trimming.
- The frequency divider circuit can be cleared so that a zero-second start of the clock can be made.

**Fig. 5-4 Clock Timer Block Diagram**

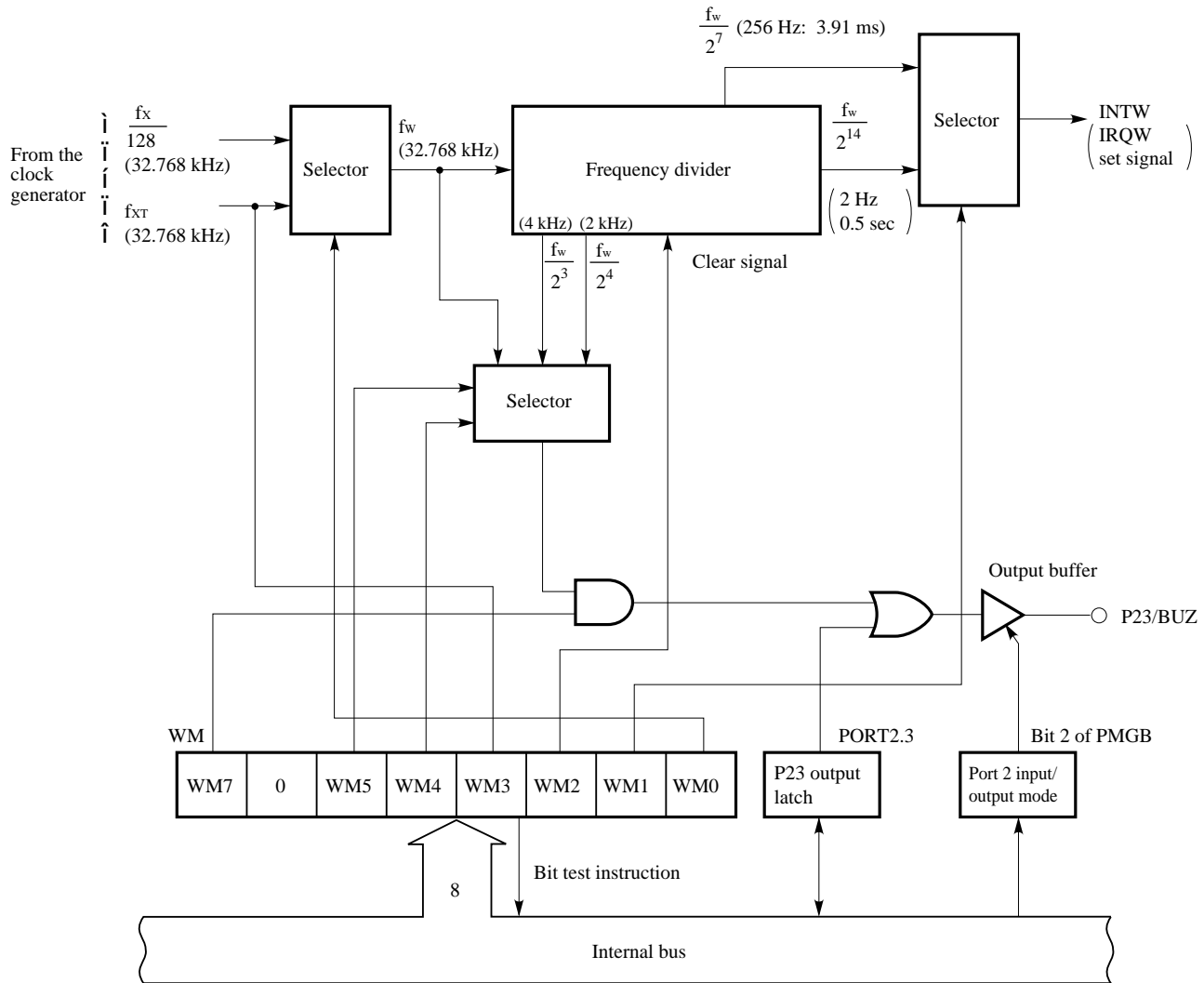

( ) is for  $f_x = 4.194304$  MHz,  $f_{XT} = 32.768$  kHz.



## 5.6 TIMER/EVENT COUNTER

The  $\mu$ PD75028 has a built-in 1-ch timer/event counter. The timer/event counter has the following functions:

- Programmable interval timer operation
- Outputs square-wave signal of an arbitrary frequency to the PTO0 pin
- Event counter operation
- Divides the TI0 pin input by N and outputs to the PTO0 pin (frequency divider operation)
- Supplies serial shift clock to the serial interface circuit
- Count condition read out function

Fig. 5-5 Timer/Event Counter Block Diagram

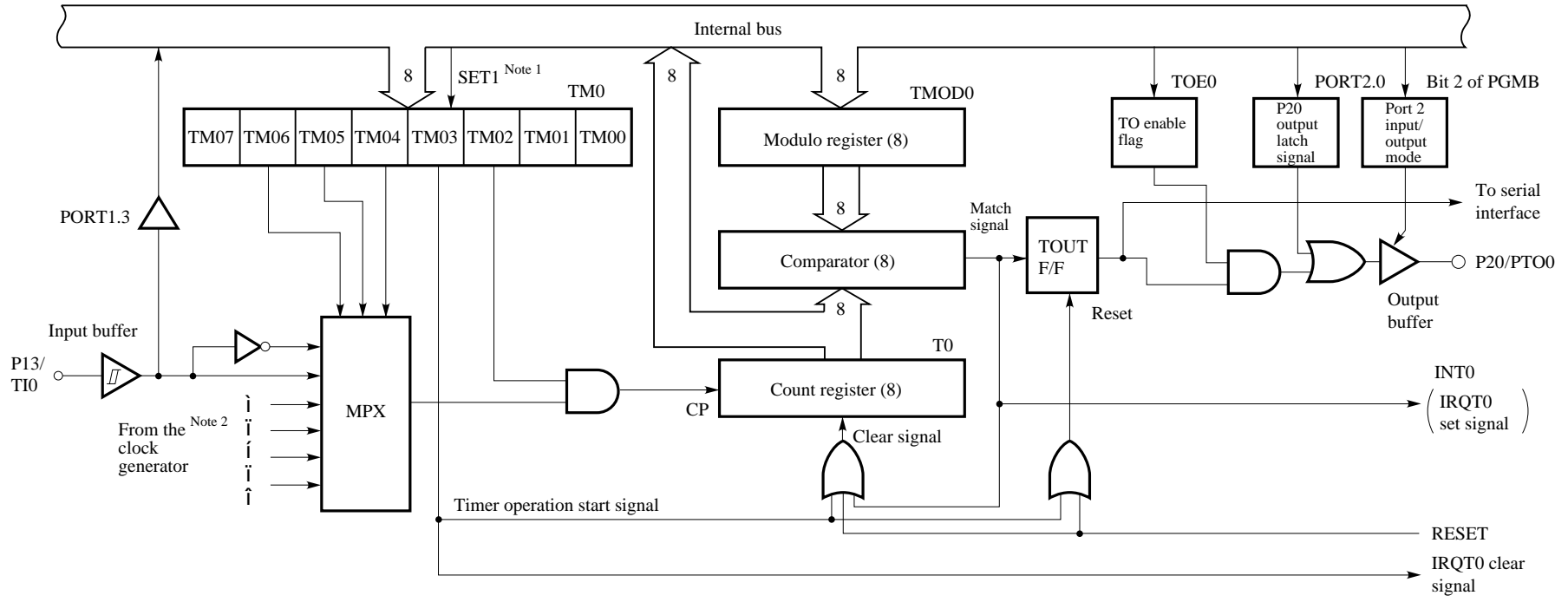

Note 1. Instruction execution  
 Note 2. For details, see Fig. 5-1.

## 5.7 SERIAL INTERFACE

The serial interface has the following modes:

- 3-wire serial I/O mode (Start bit (MSB or LSB) switchable)
- 2-wire serial I/O mode (MSB-first)
- SBI mode (MSB-first)

In 3-wire serial I/O mode, the serial interface allows connection to 75X series, 78K series, and various I/O devices.

In 2-wire serial I/O mode and SBI mode, it allows connection to two or more devices.

**Fig. 5-6 Serial Interface Block Diagram**

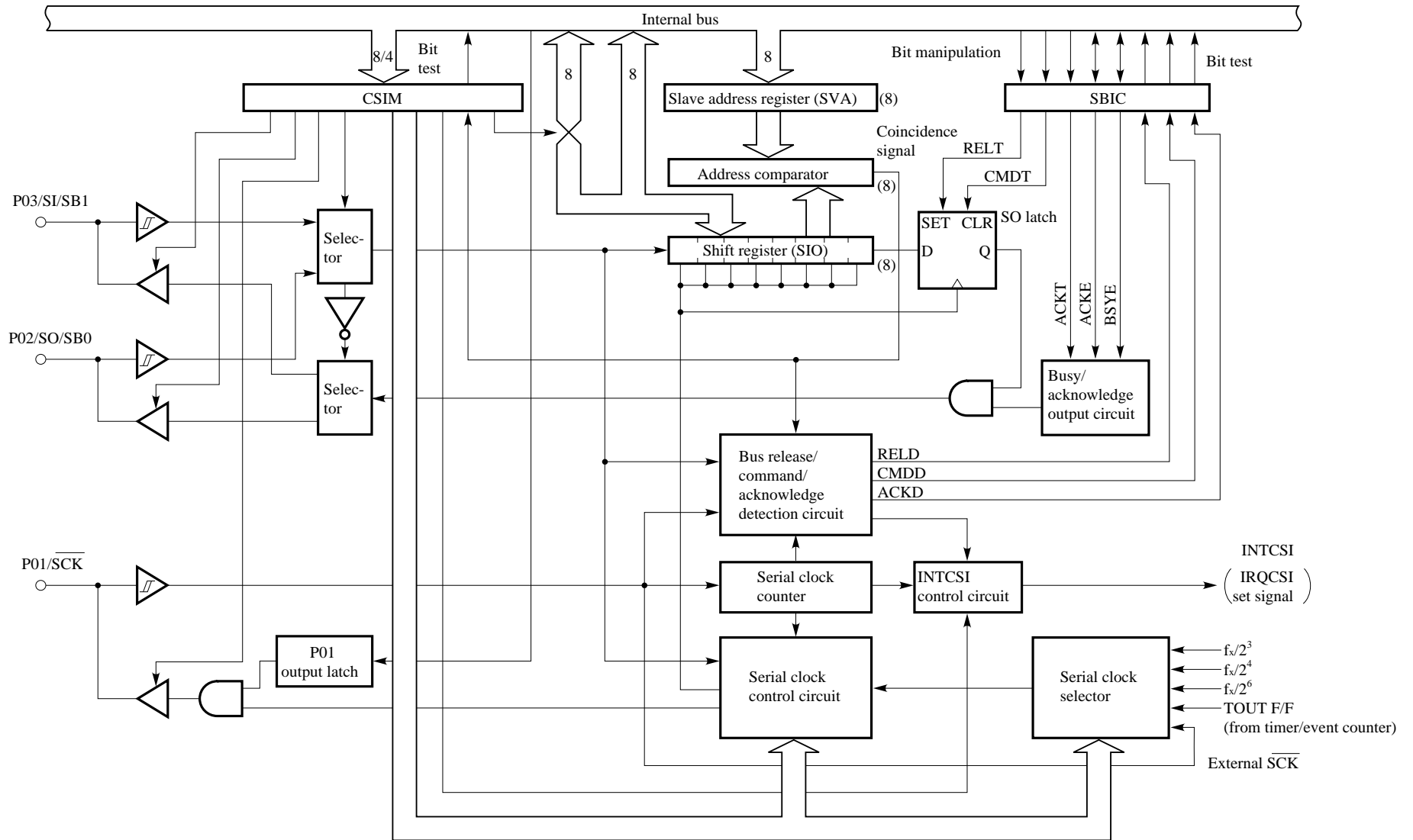

**5.8 A/D CONVERTER**

The  $\mu$ PD75028 contains an 8-bit analog/digital (A/D) converter that has eight analog input channels (AN0 - AN7).

The A/D converter employs the successive-approximation method.

**Fig. 5-7 Configuration of the A/D Converter**

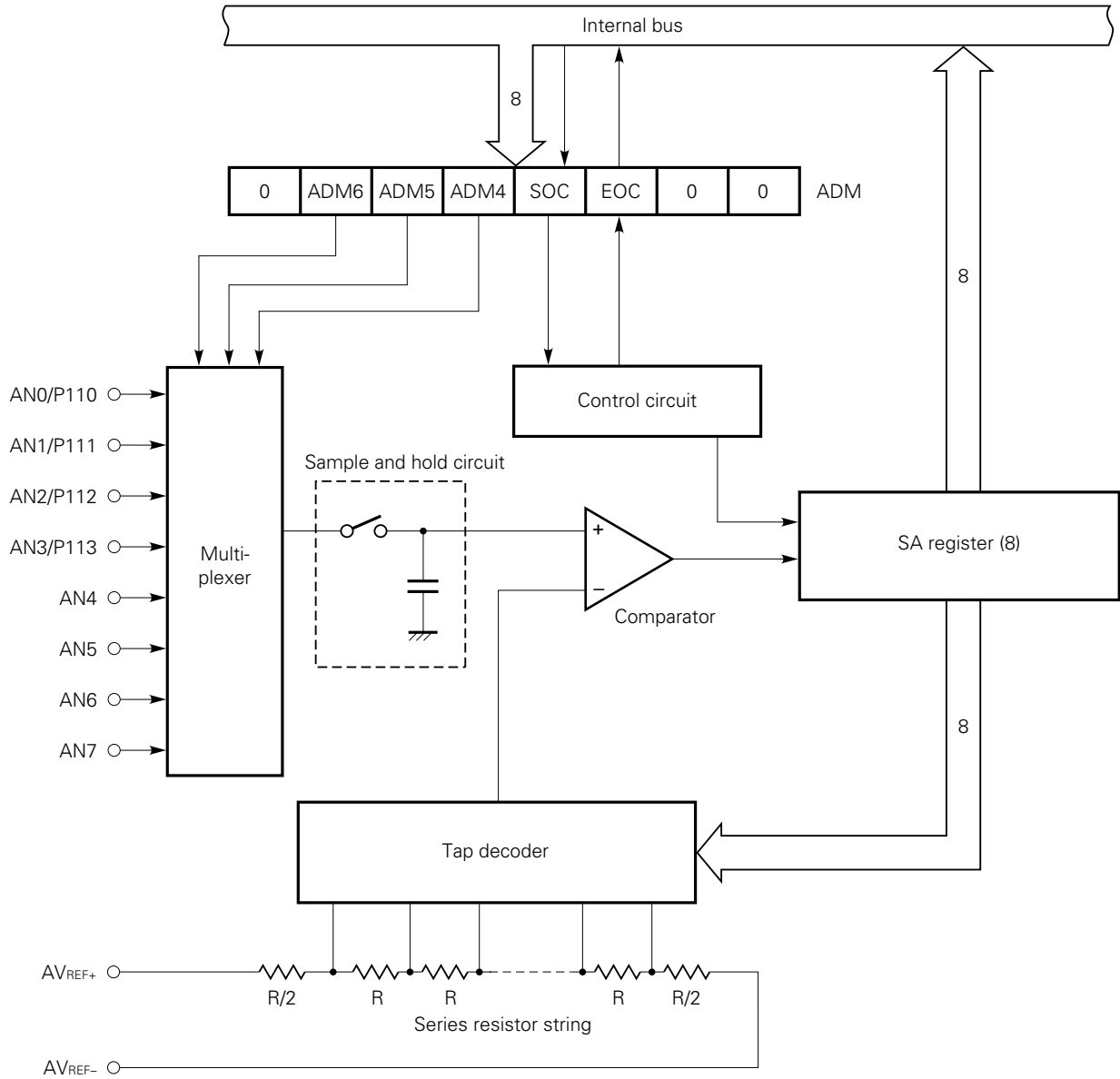

## 5.9 MULTI-FUNCTION TIMER (MFT)

The  $\mu$ PD75028 contains one channel of the multi-function timer (MFT). MFT has the following functions:

### (1) 8-bit timer mode

- Programmable interval timer operation
- Square wave output of any frequency to PPO pin

### (2) PWM output mode

- Output of 6-, 7-, or 8-bit precision PWM signal to PPO pin

### (3) 16-bit free-running timer mode

- Interval timer operation to cause an interrupt to occur at given time intervals
- Applicable as a one-shot timer

### (4) Integration A/D converter mode

- Output of 16-bit integration A/D converter control signal
- 13-, 14-, 15-, or 16-bit resolution can be selected

**Fig. 5-8 Multi-function Timer Block Diagram**

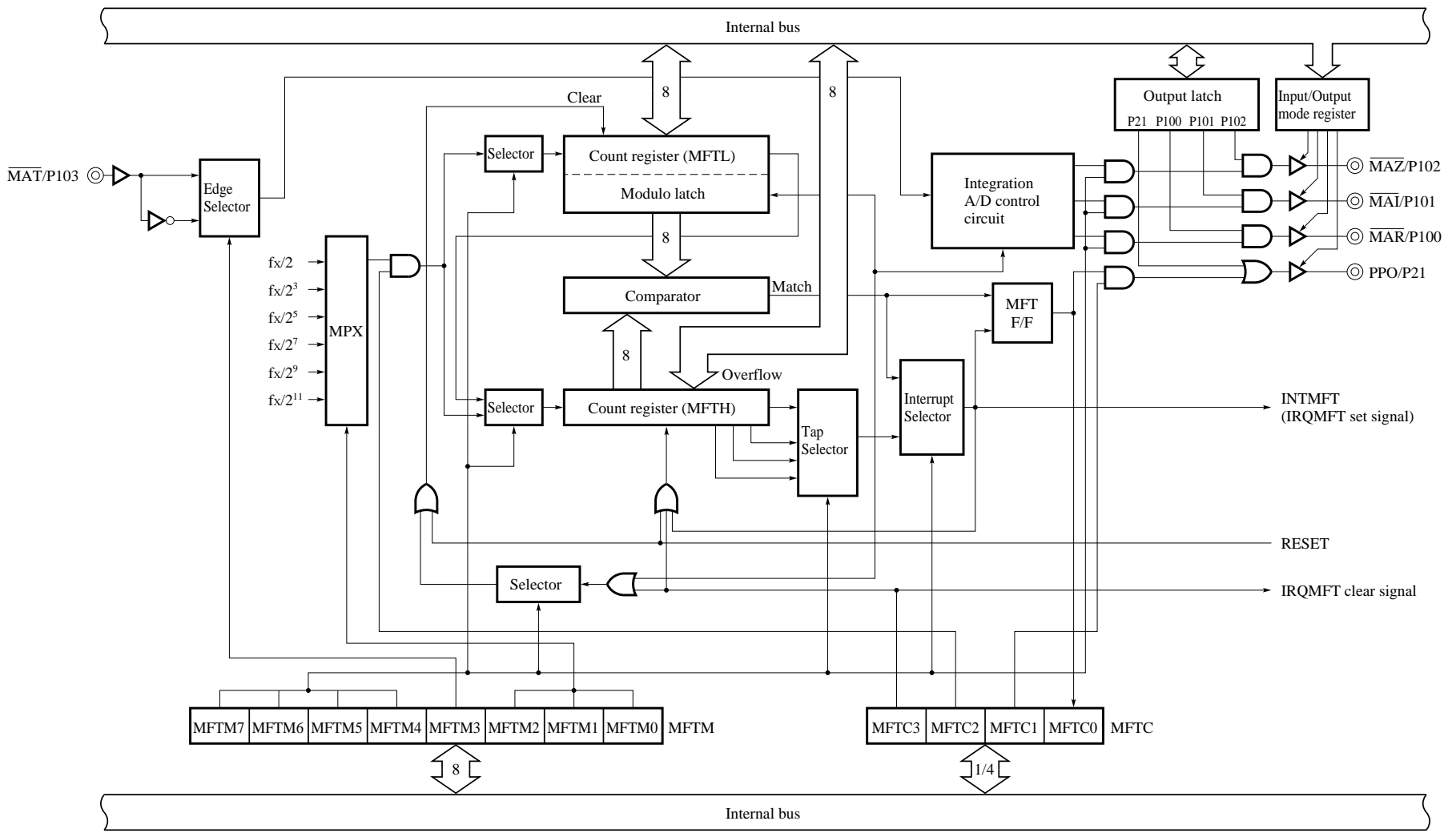

**5.10 BIT SEQUENTIAL BUFFER: 16 BITS**

The bit sequential buffer is a data memory specifically provided for bit manipulation. With this buffer, addresses and bit specifications can be sequentially updated by bit manipulation operation. Therefore, this buffer is very useful for processing long data in bit units.

**Fig. 5-9 Bit Sequential Buffer Format**

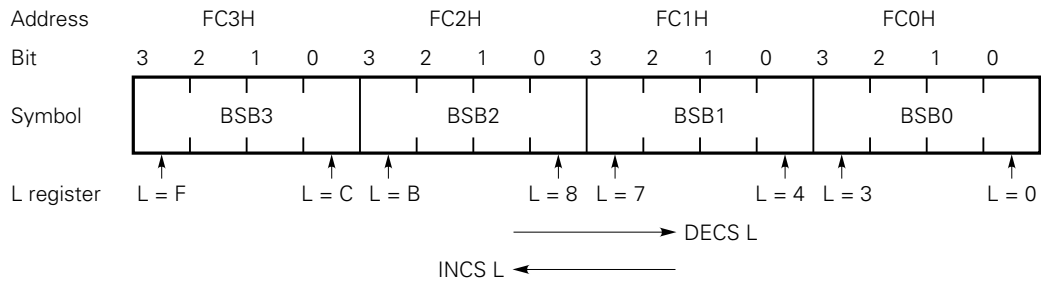

**Remark** For pmem.@L addressing, the specification bit is shifted according to the L register.



## 6. INTERRUPT FUNCTIONS

The  $\mu$ PD75028 has 7 different interrupt sources. In addition, multiple interrupts are possible by software control. Two types of test source are also provided. Of these, INT2 has two edge detection testable inputs.

The interrupt control circuit of the  $\mu$ PD75028 has the following functions:

- Hardware controlled vector interrupt function which can control whether or not to accept an interrupt using the interrupt flag (IE $\times\times\times$ ) and interrupt master enable flag (IME).
- The interrupt start address can be set arbitrarily.
- Interrupt request flag (IRQ $\times\times\times$ ) test function (an interrupt generation can be confirmed by software).
- Standby mode release (interrupts to be released can be selected by the interrupt enable flag).

**Fig. 6-1 Interrupt Control Circuit Block Diagram**

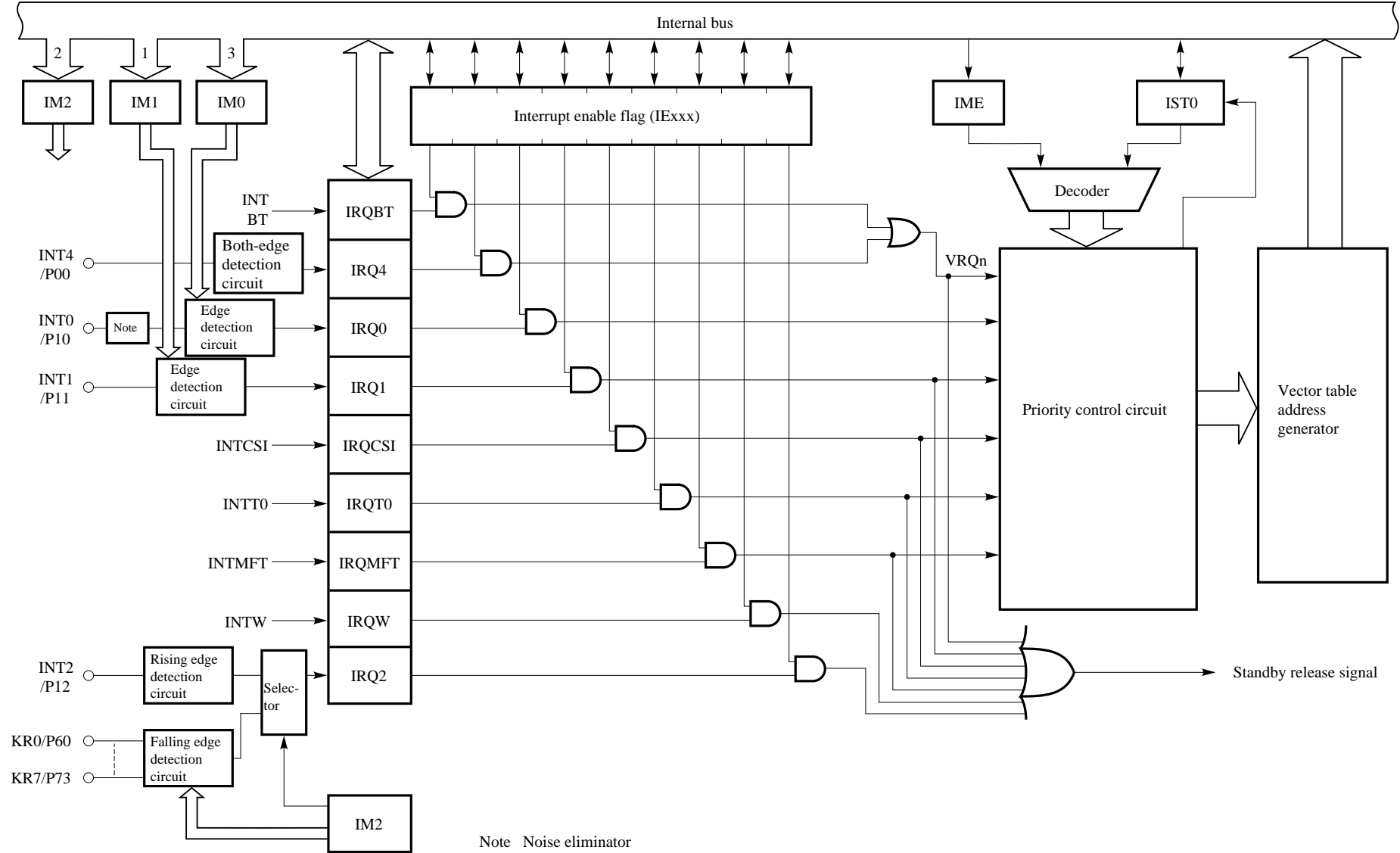

**7. STANDBY FUNCTION**

The μPD75028 has two different standby modes (STOP mode and HALT mode) to reduce power dissipation while waiting for program execution.

**Table 7-1 Standby Mode Statuses**

		STOP mode	HALT mode
Instruction for setting		STOP instruction	HALT instruction
System clock for setting		Can be set only when operating on the main system clock	Can be set either with the main system clock or the subsystem clock
Operation status	Clock generator	Only the main system clock stops its operation	Only the CPU clock $\Phi$ stops its operation (oscillation continues)
	Basic interval timer	Does not operate	Can operate only at main system clock $\Phi$ oscillation. (IROBT is set at reference time intervals.)
	Serial interface	Can operate only when the external $\overline{\text{SCK}}$ input is selected for the serial clock	Can operate only when external $\overline{\text{SCK}}$ input is selected as the serial clock or at main system clock oscillation.
	Timer/event counter	Can operate only when the TIO pin input is selected for the count clock	Can operate only when TIO pin input is specified as the count clock or at main system clock oscillation.
	Clock timer	Can operate when $\text{fxr}$ is selected as the count clock	Can operate
	A/D converter	Does not operate	Can operate <b>Note</b>
	Multi-function timer	Does not operate	Can operate <b>Note</b>
	External interrupt	INT1, INT2, and INT4 can operate. Only INT0 cannot operate.	
	CPU	Does not operate	
Release signal		An interrupt request signal from hardware whose operation is enabled by the interrupt enable flag or the $\overline{\text{RESET}}$ signal input	An interrupt request signal from hardware whose operation is enabled by the interrupt enable flag or the $\overline{\text{RESET}}$ signal input

**Note** Operation is possible only when the main system clock operates.

**8. RESET OPERATION**

When the  $\overline{\text{RESET}}$  signal is input, the μPD75028 is reset and all hardware is initialized as indicated in Table 8-1. Fig. 8-1 shows the reset operation timing.

**Fig. 8-1 Reset Operation by  $\overline{\text{RESET}}$  Input**

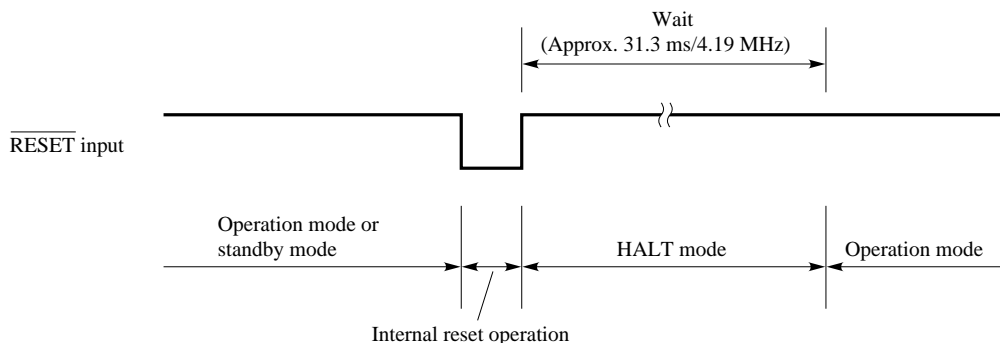

**Table 8-1 Status of All Hardware after Reset (1/2)**

Hardware		$\overline{\text{RESET}}$ input in standby mode	$\overline{\text{RESET}}$ input during operation
Program counter (PC)		The contents of the lower 5 bits of address 0000H of the program memory are set to PC12 - 8, and the contents of address 0001H are set to PC7 - 0.	
PSW	Carry flag (CY)	Retained	Undefined
	Skip flag (SK0-2)	0	0
	Interrupt status flag (IST0)	0	0
	Bank enable flag (MBE)	The contents of bit 7 of address 0000H of the program memory is set to MBE.	
Stack pointer (SP)		Undefined	Undefined
Data memory (RAM)		Retained <b>Note</b>	Undefined
General purpose register (X, A, H, L, D, E, B, C)		Retained	Undefined
Bank selection register (MBS)		0	0
Basic interval timer	Counter (BT)	Undefined	Undefined
	Mode register (BTM)	0	0
Timer/event counter	Counter (T0)	0	0
	Modulo register (TMOD0)	FFH	FFH
	Mode register (TM0)	0	0
	TOE0, TOUT F/F	0, 0	0, 0
Clock timer	Mode register (WM)	0	0

**Note** Data of address 0F8H to 0FDH of the data memory becomes undefined when the  $\overline{\text{RESET}}$  signal is input.

**Table 8-1 Status of All Hardware after Reset (2/2)**

Hardware		$\overline{\text{RESET}}$ input in standby mode	$\overline{\text{RESET}}$ input during operation
Serial interface	Shift register (SIO)	Retained	Undefined
	Operation mode register (CSIM)	0	0
	SBI control register (SBIC)	0	0
	Slave address register (SVA)	Retained	Undefined
Clock generator, Clock output circuit	Processor clock control register (PCC)	0	0
	System clock control register (SCC)	0	0
	Clock output mode register (CLOM)	0	0
Interrupt function	Interrupt enable flag (IE <sub>xxx</sub> )	0	0
	Interrupt master enable flag (IME)	0	0
	INT0, 1, 2, mode register (IM0, 1, 2)	0, 0, 0	0, 0, 0
Digital port	Output buffer	Off	Off
	Output latch	Clear (0)	Clear (0)
	Input/output mode register (PMGA, B, C)	0	0
	Pull-up resistor specification register (POGA, POGB)	0	0
	Pull-down resistor specification register (PDGB)	0	0
Multi-function timer	Counter (MFTL)	FFH	FFH
	Counter (MFTH)	0	0
	Mode register (MFTM)	0	0
	Control register (MFTC)	0	0
A/D converter	Mode register (ADM)	04H	04H
	SA register (SA)	Undefined	Undefined
Bit sequential buffer (BSB0-3)		Retained	Undefined

**9. INSTRUCTION SET**

**(1) Operand identifier and its descriptive method**

The operands are described in the operand column of each instruction according to the descriptive method for the operand format of the appropriate instructions. (For details, refer to the "RA75X Assembler Package User's Manual, Language" (EEU-xxx).) For descriptions in which alternatives exist, one element should be selected. Uppercase alphabetic characters and plus and minus signs are keywords; therefore, they should be described as they are.

For immediate data, the appropriate numerical values or labels should be described.

Symbols of various registers and flags can be described as labels instead of mem, fmem, pmem, and bit (For details, see "μPD75028 User's Manual (IEU-xxxx).").

There are restrictions to labels that can be described instead of fmem and pmem.

Identifier	Description
reg	X, A, B, C, D, E, H, L
reg1	X, B, C, D, E, H, L
rp	XA, BC, DE, HL
rp1	BC, DE, HL
rp2	BC, DE
rpa	HL, DE, DL
rpa1	DE, DL
n4	4-bit immediate data or label
n8	8-bit immediate data or label
mem <sup>Note</sup>	8-bit immediate data or label
bit	2-bit immediate data or label
fmem	FB0H - FBFH, FF0H - FFFH immediate data or label
pmem	FC0H - FFFH immediate data or label
addr	0000H - 1F7FH immediate data or label
caddr	12-bit immediate data or label
faddr	11-bit immediate data or label
taddr	20H - 7FH immediate data (however, bit 0 = 0) or label
PORTn	PORT0 - PORT11
IExxx	IEBT, IECSI, IET0, IE0, IE1, IE2, IE4, IEW, IEMFT
MBn	MB0, MB1, MB15

**Note** Only even address can be specified for mem when processing 8-bit data.

**(2) Symbol definitions in operation description**

- A : A register; 4-bit accumulator
- B : B register
- C : C register
- D : D register
- E : E register
- H : H register
- L : L register
- X : X register
- XA : Pair register (XA); 8-bit accumulator
- BC : Pair register (BC)

- DE : Pair register (DE)
- HL : Pair register (HL)
- PC : Program counter
- SP : Stack pointer
- CY : Carry flag; Bit accumulator
- PSW : Program status word
- MBE : Memory bank enable flag
- PORT<sub>n</sub> : Port n (n = 0 to 11)
- IME : Interrupt master enable flag
- IE<sub>xxx</sub> : Interrupt enable flag
- MBS : Memory bank selection register
- PCC : Processor clock control register
- . : Address, bit delimiter
- (xx) : Contents addressed by xx
- xxH : Hexadecimal data

**(3) Symbols used for the addressing area column**

*1	MB = MBE · MBS (MBS = 0, 1, 15)	<div style="display: flex; align-items: center; justify-content: center;"> <div style="border-top: 1px solid black; border-bottom: 1px solid black; width: 100%;"></div> <div style="margin: 0 10px;">↑</div> <div style="text-align: center;">Data memory addressing</div> <div style="margin: 0 10px;">↓</div> </div> <hr style="border: 0.5px solid black;"/> <div style="display: flex; align-items: center; justify-content: center;"> <div style="margin: 0 10px;">↑</div> <div style="text-align: center;">Program memory addressing</div> <div style="margin: 0 10px;">↓</div> </div>
*2	MB = 0	
*3	MBE = 0: MB = 0 (00H - 7FH) MB = 15 (80H - FFH) MBE = 1: MB = MBS (MBS = 0, 1, 15)	
*4	MB = 15, fmem = FB0H - FBFH, FF0H - FFFH	
*5	MB = 15, pmem = FC0H - FFFH	
*6	addr = 0000H - 1F7FH	
*7	addr = (Current PC) - 15 to (Current PC) - 1 (Current PC) + 2 to (Current PC) + 16	
*8	caddr = 0000H - 0FFFH (PC <sub>12</sub> = 0) or 1000H - 1F7FH (PC <sub>12</sub> = 1)	
*9	faddr = 0000H - 07FFH	
*10	taddr = 0020H - 007FH	

- Remarks**
1. MB indicates the memory bank that can be accessed.
  2. For \*2, MB = 0 regardless of MBE and MBS settings.
  3. For \*4 and \*5, MB = 15 regardless of MBE and MBS.
  4. For \*6 to \*10, each addressable area is indicated.

**(4) Description of machine cycle column**

S indicates the number of machine cycles necessary for skipping any skip instruction. The value of S changes as follows:

- When no skip is performed ..... S = 0
- When a 1-byte or 2-byte instruction is skipped ..... S = 1
- When a 3-byte instruction (BR !addr, CALL !addr instruction) is skipped ..... S = 2

**Caution** The GETI instruction is skipped in one machine cycle.

One machine cycle (= tcv) is equivalent to one CPU clock  $\Phi$  cycle. Therefore, the length of the machine cycle can be selected from three different lengths by the PCC setting.



Group	Mnemonic	Operand	Bytes	Machining cycle	Operation	Addressing area	Skip condition	
Transfer	MOV	A, #n4	1	1	$A \leftarrow n4$		String A	
		reg1, #n4	2	2	$reg1 \leftarrow n4$			
		XA, #n8	2	2	$XA \leftarrow n8$		String A	
		HL, #n8	2	2	$HL \leftarrow n8$		String B	
		rp2, #n8	2	2	$rp2 \leftarrow n8$			
		A, @HL	1	1	$A \leftarrow (HL)$	*1		
		A, @rpa1	1	1	$A \leftarrow (rpa1)$	*2		
		XA, @HL	2	2	$XA \leftarrow (HL)$	*1		
		@HL, A	1	1	$(HL) \leftarrow A$	*1		
		@HL, XA	2	2	$(HL) \leftarrow XA$	*1		
		A, mem	2	2	$A \leftarrow (mem)$	*3		
		XA, mem	2	2	$XA \leftarrow (mem)$	*3		
		mem, A	2	2	$(mem) \leftarrow A$	*3		
		mem, XA	2	2	$(mem) \leftarrow XA$	*3		
		A, reg	2	2	$A \leftarrow reg$			
		XA, rp	2	2	$XA \leftarrow rp$			
		reg1, A	2	2	$reg1 \leftarrow A$			
		rp1, XA	2	2	$rp1 \leftarrow XA$			
	XCH	A, @HL	1	1	$A \leftrightarrow (HL)$	*1		
		A, @rpa1	1	1	$A \leftrightarrow (rpa1)$	*2		
		XA, @HL	2	2	$XA \leftrightarrow (HL)$	*1		
		A, mem	2	2	$A \leftrightarrow (mem)$	*3		
		XA, mem	2	2	$XA \leftrightarrow (mem)$	*3		
		A, reg1	1	1	$A \leftrightarrow reg1$			
		XA, rp	2	2	$XA \leftrightarrow rp$			
	MOVT	XA, @PCDE	1	3	$XA \leftarrow (PC_{12-8} + DE)_{ROM}$			
		XA, @PCXA	1	3	$XA \leftarrow (PC_{12-8} + XA)_{ROM}$			
	Arithmetic	ADDS	A, #n4	1	1 + S	$A \leftarrow A + n4$		carry
			A, @HL	1	1 + S	$A \leftarrow A + (HL)$	*1	carry
		ADDC	A, @HL	1	1	$A, CY \leftarrow A + (HL) + CY$	*1	
SUBS		A, @HL	1	1 + S	$A \leftarrow A - (HL)$	*1	borrow	
SUBC		A, @HL	1	1	$A, CY \leftarrow A - (HL) - CY$	*1		
AND		A, #n4	2	2	$A \leftarrow A \wedge n4$			
		A, @HL	1	1	$A \leftarrow A \wedge (HL)$	*1		
OR		A, #n4	2	2	$A \leftarrow A \vee n4$			
		A, @HL	1	1	$A \leftarrow A \vee (HL)$	*1		
XOR		A, #n4	2	2	$A \leftarrow A \nabla n4$			
	A, @HL	1	1	$A \leftarrow A \nabla (HL)$	*1			

Group	Mnemonic	Operand	Bytes	Machining cycle	Operation	Addressing area	Skip condition
Accumulator manipulation	RORC	A	1	1	$CY \leftarrow A_0, A_3 \leftarrow CY, A_{n-1} \leftarrow A_n$		
	NOT	A	2	2	$A \leftarrow \bar{A}$		
Increment/decrement	INCS	reg	1	1 + S	$reg \leftarrow reg + 1$		reg = 0
		@HL	2	2 + S	$(HL) \leftarrow (HL) + 1$	*1	(HL) = 0
		mem	2	2 + S	$(mem) \leftarrow (mem) + 1$	*3	(mem) = 0
	DECS	reg	1	1 + S	$reg \leftarrow reg - 1$		reg = FH
Comparison	SKE	reg, #n4	2	2 + S	Skip if reg = n4		reg = n4
		@HL, #n4	2	2 + S	Skip if (HL) = n4	*1	(HL) = n4
		A, @HL	1	1 + S	Skip if A = (HL)	*1	A = (HL)
		A, reg	2	2 + S	Skip if A = reg		A = reg
Carry flag manipulation	SET1	CY	1	1	$CY \leftarrow 1$		
	CLR1	CY	1	1	$CY \leftarrow 0$		
	SKT	CY	1	1 + S	Skip if CY = 1		CY = 1
	NOT1	CY	1	1	$CY \leftarrow \bar{CY}$		
Memory bit manipulation	SET1	mem.bit	2	2	$(mem.bit) \leftarrow 1$	*3	
		fmem.bit	2	2	$(fmem.bit) \leftarrow 1$	*4	
		pmem.@L	2	2	$(pmem_{7-2} + L_{3-2}.bit(L_{1-0})) \leftarrow 1$	*5	
		@H+mem.bit	2	2	$(H + mem_{3-0}.bit) \leftarrow 1$	*1	
	CLR1	mem.bit	2	2	$(mem.bit) \leftarrow 0$	*3	
		fmem.bit	2	2	$(fmem.bit) \leftarrow 0$	*4	
		pmem.@L	2	2	$(pmem_{7-2} + L_{3-2}.bit(L_{1-0})) \leftarrow 0$	*5	
		@H+mem.bit	2	2	$(H + mem_{3-0}.bit) \leftarrow 0$	*1	
	SKT	mem.bit	2	2 + S	Skip if (mem.bit) = 1	*3	(mem.bit) = 1
		fmem.bit	2	2 + S	Skip if (fmem.bit) = 1	*4	(fmem.bit) = 1
		pmem.@L	2	2 + S	Skip if $(pmem_{7-2} + L_{3-2}.bit(L_{1-0})) = 1$	*5	(pmem.@L) = 1
		@H+mem.bit	2	2 + S	Skip if $(H + mem_{3-0}.bit) = 1$	*1	(@H + mem.bit) = 1
	SKF	mem.bit	2	2 + S	Skip if (mem.bit) = 0	*3	(mem.bit) = 0
		fmem.bit	2	2 + S	Skip if (fmem.bit) = 0	*4	(fmem.bit) = 0
		pmem.@L	2	2 + S	Skip if $(pmem_{7-2} + L_{3-2}.bit(L_{1-0})) = 0$	*5	(pmem.@L) = 0
		@H+mem.bit	2	2 + S	Skip if $(H + mem_{3-0}.bit) = 0$	*1	(@H + mem.bit) = 0
	SKTCLR	fmem.bit	2	2 + S	Skip if (fmem.bit) = 1 and clear	*4	(fmem.bit) = 1
		pmem.@L	2	2 + S	Skip if $(pmem_{7-2} + L_{3-2}.bit(L_{1-0})) = 1$ and clear	*5	(pmem.@L) = 1
		@H+mem.bit	2	2 + S	Skip if $(H + mem_{3-0}.bit) = 1$ and clear	*1	(@H + mem.bit) = 1
	AND1	CY, fmem.bit	2	2	$CY \leftarrow CY \wedge (fmem.bit)$	*4	
		CY, pmem.@L	2	2	$CY \leftarrow CY \wedge (pmem_{7-2} + L_{3-2}.bit(L_{1-0}))$	*5	
		CY, @H+mem.bit	2	2	$CY \leftarrow CY \wedge (H + mem_{3-0}.bit)$	*1	
	OR1	CY, fmem.bit	2	2	$CY \leftarrow CY \vee (fmem.bit)$	*4	
		CY, pmem.@L	2	2	$CY \leftarrow CY \vee (pmem_{7-2} + L_{3-2}.bit(L_{1-0}))$	*5	
		CY, @H+mem.bit	2	2	$CY \leftarrow CY \vee (H + mem_{3-0}.bit)$	*1	

Group	Mnemonic	Operand	Bytes	Machining cycle	Operation	Addressing area	Skip condition
Memory bit manipulation	XOR1	CY, fmem.bit	2	2	$CY \leftarrow CY \nabla (fmem.bit)$	*4	
		CY, pmem.@L	2	2	$CY \leftarrow CY \nabla (pmem_{7-2} + L_{3-2}.bit(L_{1-0}))$	*5	
		CY, @H+mem.bit	2	2	$CY \leftarrow CY \nabla (H + mem_{3-0}.bit)$	*1	
Branch	BR	addr	-	-	$PC_{12-0} \leftarrow addr$ (Appropriate instructions are selected from BR !addr, BRCB !caddr, and BR \$addr by the assembler.)	*6	
		!addr	3	3	$PC_{12-0} \leftarrow addr$	*6	
		\$addr	1	2	$PC_{12-0} \leftarrow addr$	*7	
	BRCB	!caddr	2	2	$PC_{12-0} \leftarrow PC_{12} + caddr_{11-0}$	*8	
Subroutine stack control	CALL	!addr	3	3	$(SP - 4)(SP - 1)(SP - 2) \leftarrow PC_{11-0}$ $(SP - 3) \leftarrow MBE, 0, 0, PC_{12}$ $PC_{12-0} \leftarrow addr, SP \leftarrow SP - 4$	*6	
	CALLF	!faddr	2	2	$(SP - 4)(SP - 1)(SP - 2) \leftarrow PC_{11-0}$ $(SP - 3) \leftarrow MBE, 0, 0, PC_{12}$ $PC_{12-0} \leftarrow 00, faddr, SP \leftarrow SP - 4$	*9	
	RET		1	3	$MBE, \times, \times, PC_{12} \leftarrow (SP + 1)$ $PC_{11-0} \leftarrow (SP)(SP + 3)(SP + 2)$ $SP \leftarrow SP + 4$		
	RETS		1	3 + S	$MBE, \times, \times, PC_{12} \leftarrow (SP + 1)$ $PC_{11-0} \leftarrow (SP)(SP + 3)(SP + 2)$ $SP \leftarrow SP + 4$ , then skip unconditionally		Unconditional
	RETI		1	3	$MBE, \times, \times, PC_{12} \leftarrow (SP + 1)$ $PC_{11-0} \leftarrow (SP)(SP + 3)(SP + 2)$ $PSW \leftarrow (SP + 4)(SP + 5), SP \leftarrow SP + 6$		
		PUSH	rp	1	1	$(SP - 1)(SP - 2) \leftarrow rp, SP \leftarrow SP - 2$	
		BS	2	2	$(SP - 1) \leftarrow MBS, (SP - 2) \leftarrow 0, SP \leftarrow SP - 2$		
	POP	rp	1	1	$rp \leftarrow (SP + 1)(SP), SP \leftarrow SP + 2$		
BS		2	2	$MBS \leftarrow (SP + 1), SP \leftarrow SP + 2$			
Interrupt control	EI		2	2	$IME \leftarrow 1$		
		IE <sub>xxx</sub>	2	2	$IE_{xxx} \leftarrow 1$		
	DI		2	2	$IME \leftarrow 0$		
		IE <sub>xxx</sub>	2	2	$IE_{xxx} \leftarrow 0$		
Input/output	IN	A, PORT <sub>n</sub>	2	2	$A \leftarrow PORT_n \quad (n = 0 - 11)$		
		XA, PORT <sub>n</sub>	2	2	$XA \leftarrow PORT_{n+1}, PORT_n \quad (n = 4, 6)$		
	OUT	PORT <sub>n</sub> , A	2	2	$PORT_n \leftarrow A \quad (n = 2 - 10)$		
		PORT <sub>n</sub> , XA	2	2	$PORT_{n+1}, PORT_n \leftarrow XA \quad (n = 4, 6)$		
CPU control	HALT		2	2	Set HALT Mode (PCC.2 ← 1)		
	STOP		2	2	Set STOP Mode (PCC.3 ← 1)		
	NOP		1	1	No Operation		

**Caution** When executing the IN/OUT instruction, MBE must be set to 0 or MBE and MBS must be set to 1 and 15, respectively.

Group	Mnemonic	Operand	Bytes	Machining cycle	Operation	Addressing area	Skip condition
Special	SEL	MBn	2	2	$MBS \leftarrow n$ ( $n = 0, 1, 15$ )		
	GETI	taddr	1	3	<ul style="list-style-type: none"> <li>• For the TBR instruction  <math>PC_{12-0} \leftarrow (taddr)_{4-0} + (taddr + 1)</math></li> <li>• For the TCALL instruction  <math>(SP - 4)(SP - 1)(SP - 2) \leftarrow PC_{11-0}</math>  <math>(SP - 3) \leftarrow MBE, 0, 0, PC_{12}</math>  <math>PC_{12-0} \leftarrow (taddr)_{4-0} + (taddr + 1)</math>  <math>SP \leftarrow SP - 4</math></li> <li>• For other than the TBR and TCALL instruction                      (taddr) (taddr + 1) is executed.</li> </ul>	*10	Depends on the reference instruction

**10. ELECTRICAL SPECIFICATIONS**

**Absolute maximum ratings** (T<sub>a</sub> = 25 °C)

Parameter	Symbol	Test conditions		Ratings	Unit
Power supply voltage	V <sub>DD</sub>			-0.3 to +7.0	V
Input voltage	V <sub>I1</sub>	Except for port 4, 5, 10		-0.3 to V <sub>DD</sub> +0.3	V
	V <sub>I2</sub>	Port 4, 5, 10	Pull-up resistor is contained	-0.3 to V <sub>DD</sub> +0.3	V
			Open drain	-0.3 to +11	V
Output voltage	V <sub>O</sub>			-0.3 to V <sub>DD</sub> +0.3	V
Output high current	I <sub>OH</sub>	Each output pin		-10	mA
		Total		-30	mA
Output low current	I <sub>OL</sub> <b>Note</b>	Port 0, 3, 4, 5 Each output pin	Peak value	30	mA
			rms value	15	mA
		Except for port 0, 3, 4, 5 Each output pin	Peak value	20	mA
			rms value	5	mA
		Port 0, 3 to 9, 11 total	Peak value	170	mA
			rms value	120	mA
		Port 0, 2, 10 total	Peak value	30	mA
			rms value	20	mA
Operation temperature	T <sub>opt</sub>			-40 to +70	°C
Storage temperature	T <sub>stg</sub>			-65 to +150	°C

**Note** To obtain the rms value, calculate  
 [rms value] = [peak value] × √duty

**Caution** If any of the ratings described above should exceed the specified absolute maximum rating even for a moment, the quality of the product would be impaired. An absolute maximum rating is a critical value that can physically damage the product. Be sure to use the product under conditions within the absolute maximum ratings.

**Capacitance** (T<sub>a</sub> = 25 °C, V<sub>DD</sub> = 0 V)

Parameter	Symbol	Test conditions	MIN.	TYP.	MAX.	Unit
Input capacitance	C <sub>I</sub>	f = 1MHz			15	pF
Output capacitance	C <sub>O</sub>	Unmeasured pins returned to 0 V			15	pF
Input/Output capacitance	C <sub>IO</sub>				15	pF

**Main system clock oscillator characteristics** ( $T_a = -40$  to  $+70$  °C,  $V_{DD} = 2.7$  to  $6.0$  V)

Resonator	Recommended constants	Parameter	Test conditions	MIN.	TYP.	MAX.	Unit
Ceramic resonator		Oscillation frequency ( $f_x$ ) <b>Note 1</b>	$V_{DD}$ = oscillator operating voltage range	2.0		5.0 <b>Note 3</b>	MHz
		Oscillation stabilization time <b>Note 2</b>	After $V_{DD}$ reaches the minimum oscillator operating voltage range			4	ms
Crystal resonator		Oscillation frequency ( $f_x$ ) <b>Note 1</b>		2.0	4.19	5.0 <b>Note 3</b>	MHz
		Oscillation stabilization time <b>Note 2</b>	$V_{DD} = 4.5$ to $6.0$ V			10	ms
							30
External clock		X1 input frequency ( $f_x$ ) <b>Note 1</b>		2.0		5.0 <b>Note 3</b>	MHz
		X1 input high- and low-level width ( $t_{xH}$ , $t_{xL}$ )		100		250	ns

**Note 1.** Indicates only the characteristics of the oscillator. For instruction execution time, see "AC Characteristics."

2. Time required for stabilization of oscillation after application of  $V_{DD}$  or after cancellation of STOP mode.

★ 3. If the oscillation frequency is  $4.19 \text{ MHz} < f_x \leq 5.0 \text{ MHz}$ , do not select PCC = 0011 as instruction execution time. If it is selected, one machine cycle would become shorter than  $0.95 \mu\text{s}$ , and the minimum limit of  $0.95 \mu\text{s}$  could not be secured.

★ **Caution** In use of the main system clock oscillator, follow the following guidelines for wiring on the portion indicated by "□" in the figure to avoid influence due to line capacitance:

- Route as short as possible.
- Do not let the wiring cross another signal line.
- Do not place the wiring near a line in which a variable high current flows.
- Be sure that the potential on the connection point for the oscillator capacitor is always equal to  $V_{DD}$ . Do not connect the wire in question to a power supply pattern in which a high current flows.
- Do not take off signal from the oscillator.

**Subsystem clock oscillator characteristics** ( $T_a = -40$  to  $+70$  °C,  $V_{DD} = 2.7$  to  $6.0$  V)

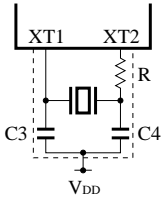
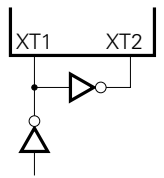
Resonator	Recommended constants	Parameter	Test conditions	MIN.	TYP.	MAX.	Unit
Crystal resonator		Oscillation frequency ( $f_{XT}$ ) <b>Note 1</b>		32	32.768	35	kHz
		Oscillation stabilization time <b>Note 2</b>	$V_{DD} = 4.5$ to $6.0$ V		1.0	2	s
							10
External clock		XT1 input frequency ( $f_{XT}$ ) <b>Note 1</b>		32		100	kHz
		XT1 input high- and low-level width ( $t_{XTH}$ , $t_{XTL}$ )		5		15	μs

- Note 1.** Indicates only the characteristics of the oscillator. For instruction execution time, see "AC Characteristics."
- 2.** Time required for stabilization of oscillation after application of  $V_{DD}$ .

**Caution** In use of the subsystem clock oscillator, follow the following guidelines for wiring on the portion indicated by "□" in the figure to avoid influence due to line capacitance: ★

- Route as short as possible wire.
- Do not let the wiring cross another signal line.
- Do not place the wiring near a line in which a variable high current flows.
- Be sure that the potential on the connection point for the oscillator capacitor is always equal to  $V_{DD}$ . Do not connect the wire in question to a power supply pattern in which a high current flows.
- Do not take off signal from the oscillator.

For reduction of current consumption, the subsystem clock oscillator has a low amplification factor. It is more likely to have a malfunction due to noise than the main system clock oscillator. When the subsystem clock is to be used, pay special attention in selecting the method of wiring.

★ Recommended oscillator constants

**Main system clock: Ceramic (T<sub>a</sub> = -40 to +85 °C)**

Manufacturer	Product	Frequency (MHz)	Recommended circuit constant		Oscillation voltage range	
			C1 (pF)	C2 (PF)	MIN. (V)	MAX. (V)
Murata	CSA X.XXMG <sup>Note</sup>	2.00 to 2.44	30	30	3.0	6.0
	CST X.XXMG <sup>Note</sup>		—	—		
	CSA X.XXMG <sup>Note</sup>	2.45 to 4.49	30	30	3.5	
	CST X.XXMGW <sup>Note</sup>		—	—		
	CSA X.XXMG <sup>Note</sup>	4.50 to 5.00	30	30	4.0	
	CST X.XXMGW <sup>Note</sup>		—	—		
Kyocera	KBR-1000H	1.00	100	100	2.7	6.0
	KBR-2.0MS	2.00	47	47		
	KBR-4.0MSA	4.00	33	33		
	KBR-5.0MSA	5.00	33	33		

**Note** X.XX indicates a frequency.

**Subsystem clock: Crystal (T<sub>a</sub> = -15 to +60 °C)**

Manufacturer	Product	Frequency (kHz)	Recommended circuit constant			Oscillation voltage range	
			C3 (pF)	C4 (pF)	R (kΩ)	MIN. (V)	MAX. (V)
Kyocera	KF-38G	32.768	18	33	150	2.7	6.0



DC characteristics (T<sub>a</sub> = -40 to +70 °C, V<sub>DD</sub> = 2.7 to 6.0 V)

Parameter	Symbol	Test conditions		MIN.	TYP.	MAX.	Unit
Input high voltage	V <sub>IH1</sub>	Port 2, 3, 8, 9, 11		0.7 V <sub>DD</sub>		V <sub>DD</sub>	V
	V <sub>IH2</sub>	Port 0, 1, 6, 7, RESET		0.8 V <sub>DD</sub>		V <sub>DD</sub>	V
	V <sub>IH3</sub>	Port 4, 5, 10	Pull-up resistor is contained	0.7 V <sub>DD</sub>		V <sub>DD</sub>	V
			Open drain	0.7 V <sub>DD</sub>		10	V
V <sub>IH4</sub>	X1, X2, XT1, XT2		V <sub>DD</sub> - 0.5		V <sub>DD</sub>	V	
Input low voltage	V <sub>IL1</sub>	Port 2 to 5, 8 to 11		0		0.3 V <sub>DD</sub>	V
	V <sub>IL2</sub>	Port 0, 1, 6, 7, RESET		0		0.2 V <sub>DD</sub>	V
	V <sub>IL3</sub>	X1, X2, XT1, XT2		0		0.4	V
Output high voltage	V <sub>OH</sub>	V <sub>DD</sub> = 4.5 to 6.0 V, I <sub>OH</sub> = -1 mA		V <sub>DD</sub> - 1.0			V
		I <sub>OH</sub> = -100 μA		V <sub>DD</sub> - 0.5			V
Output low voltage	V <sub>OL</sub>	Port 3, 4, 5	V <sub>DD</sub> = 4.5 to 6.0 V, I <sub>OL</sub> = 15 mA		0.4	2.0	V
		V <sub>DD</sub> = 4.5 to 6.0 V, I <sub>OL</sub> = 1.6 mA				0.4	V
		I <sub>OL</sub> = 400 μA				0.5	V
		SB0, 1	Open drain Pull-up resistor ≥ 1 kΩ			0.2 V <sub>DD</sub>	V
Input high leakage current	I <sub>LIH1</sub>	V <sub>I</sub> = V <sub>DD</sub>	Except for below			3	μA
	I <sub>LIH2</sub>		X1, X2, XT1			20	μA
	I <sub>LIH3</sub>	V <sub>I</sub> = 9 V	Port 4, 5, 10 (when open drain is selected)			20	μA
Input low leakage current	I <sub>LIL1</sub>	V <sub>I</sub> = 0 V	Except for below			-3	μA
	I <sub>LIL2</sub>		X1, X2, XT1			-20	μA
Output high leakage current	I <sub>LOH1</sub>	V <sub>O</sub> = V <sub>DD</sub>	Except for below			3	μA
	I <sub>LOH2</sub>	V <sub>O</sub> = 9 V	Port 4, 5, 10 (when open drain is selected)			20	μA
Output low leakage current	I <sub>LOL</sub>	V <sub>O</sub> = 0 V				-3	μA
Internal pull-up resistor	R <sub>U1</sub>	Port 0, 1, 2, 3, 6, 7, 8 (except P00) V <sub>I</sub> = 0 V	V <sub>DD</sub> = 5.0 V ± 10 %	15	40	80	kΩ
			V <sub>DD</sub> = 3.0 V ± 10 %	30		300	kΩ
	R <sub>U2</sub>	Port 4, 5, 10 V <sub>O</sub> = V <sub>DD</sub> - 2.0 V	V <sub>DD</sub> = 5.0 V ± 10 %	15	40	70	kΩ
			V <sub>DD</sub> = 3.0 V ± 10 %	10		60	kΩ
Internal pull-down resistor	R <sub>D</sub>	Port 9 V <sub>IN</sub> = V <sub>DD</sub>	V <sub>DD</sub> = 5.0 V ± 10 %	10	40	70	kΩ
			V <sub>DD</sub> = 3.0 V ± 10 %	10		60	kΩ

Parameter	Symbol	Test conditions		MIN.	TYP.	MAX.	Unit	
Power supply current <b>Note 1</b>	I <sub>DD1</sub>	4.19 MHz <b>Note 2</b> crystal oscillation C1 = C2 = 22 pF	V <sub>DD</sub> = 5.0 V ±10 % <b>Note 3</b>		2.5	8	mA	
			V <sub>DD</sub> = 3 V ± 10 % <b>Note 4</b>		0.35	1.2	mA	
	I <sub>DD2</sub>	32.768 <b>Note 5</b> kHz crystal oscillation	HALT mode	V <sub>DD</sub> = 5 V ±10 %		500	1500	μA
				V <sub>DD</sub> = 3 V ±10 %		150	450	μA
	I <sub>DD3</sub>		V <sub>DD</sub> = 3 V ±10 %		30	90	μA	
	I <sub>DD4</sub>		HALT mode	V <sub>DD</sub> = 3 V ±10 %		5	15	μA
	I <sub>DD5</sub>	XT1 = 0 V STOP mode		V <sub>DD</sub> = 5 V ±10 %		0.5	20	μA
				V <sub>DD</sub> = 3 V ±10 %		0.1	10	μA
			T <sub>a</sub> = 25 °C		0.1	5	μA	

- Note 1.** Current flowing into internal pull-up resistor is not contained.
- 2.** Case where subsystem clock is oscillated is also contained.
- 3.** When the processor clock control register (PCC) is set to 0011 and the μPD75028 is operated in high speed mode.
- 4.** When PCC is set to 0000 and the μPD75028 is operated in low speed mode.
- 5.** When the system clock control register (SCC) is set to 1001, main system clock oscillation is stopped and the μPD75028 is operated with subsystem clock.

**AC characteristics** ( $T_a = -40$  to  $+70$  °C,  $V_{DD} = 2.7$  to  $6.0$  V)

Parameter	Symbol	Test conditions	MIN.	TYP.	MAX.	Unit	
CPU clock cycle time (minimum instruction execution time = 1 machine cycle) <b>Note 1</b>	$t_{CY}$	Operation with main system clock	$V_{DD} = 4.5$ to $6.0$ V	0.95		32	μs
				3.8		32	μs
		Operation with subsystem clock		114	122	125	μs
TIO input frequency	$f_{TI}$	$V_{DD} = 4.5$ to $6.0$ V	0		1	MHz	
			0		275	kHz	
TIO input high, low level width	$t_{TIH}$ , $t_{TIL}$	$V_{DD} = 4.5$ to $6.0$ V	0.48			μs	
			1.8			μs	
Interrupt input high, low level width	$t_{INTH}$ , $t_{INTL}$	INT0	<b>Note 2</b>			μs	
		INT1, 2, 4	10			μs	
		KR0 to 7	10			μs	
RESET low level width	$t_{RSL}$		10			μs	

**Note 1.** The CPU clock ( $\Phi$ ) cycle time (minimum instruction execution time) is determined by the oscillation frequency of the connected resonator, the system clock control register (SCC), and the processor clock control register (PCC).

The right chart shows the cycle time  $t_{CY}$  characteristics for power supply voltage  $V_{DD}$  during main system clock operation.

- 2 $t_{CY}$  or 128/f<sub>x</sub> depending on how the interrupt mode register (IM0) is set.

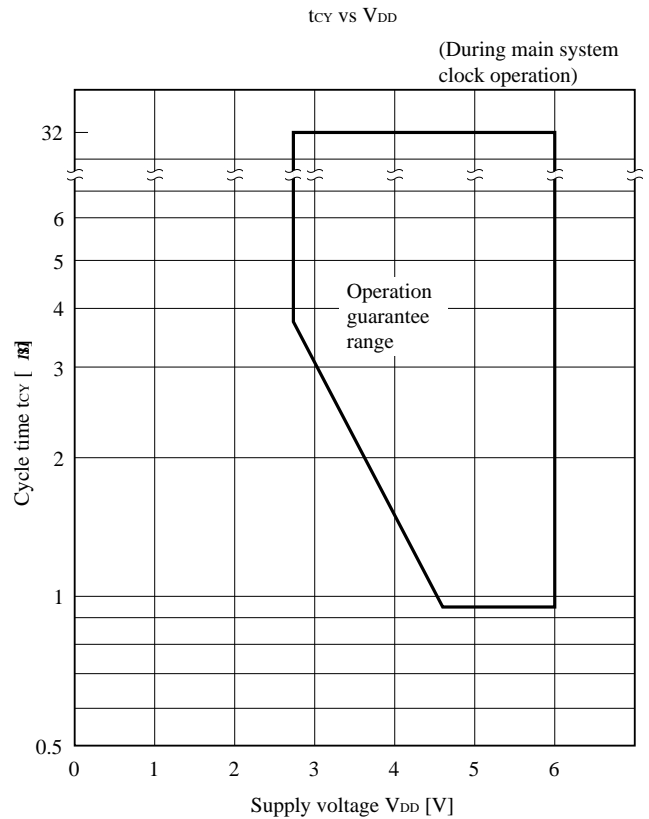

**Serial transfer operation**

**2-wire, 3-wire serial I/O mode ( $\overline{\text{SCK}}$  - internal clock output)**

Parameter	Symbol	Test conditions	MIN.	TYP.	MAX.	Unit	
$\overline{\text{SCK}}$ cycle time	t <sub>KCY1</sub>	V <sub>DD</sub> = 4.5 to 6.0 V	1600			ns	
			3800			ns	
$\overline{\text{SCK}}$ high, low level width	t <sub>KL1</sub> t <sub>KH1</sub>	V <sub>DD</sub> = 4.5 to 6.0 V	t <sub>KCY1</sub> /2-50			ns	
			t <sub>KCY1</sub> /2-150			ns	
SI setup time (to $\overline{\text{SCK}}$ ↑)	t <sub>SIK1</sub>		150			ns	
SI hold time (from $\overline{\text{SCK}}$ ↑)	t <sub>KSI1</sub>		400			ns	
$\overline{\text{SCK}}$ ↓ → SO output delay time	t <sub>KSO1</sub>	R <sub>L</sub> = 1 kΩ, <b>Note</b> C <sub>L</sub> = 100 pF	V <sub>DD</sub> = 4.5 to 6.0 V	0		250	ns
				0		1000	ns

**2-wire, 3-wire serial I/O mode ( $\overline{\text{SCK}}$  - external clock input)**

Parameter	Symbol	Test conditions	MIN.	TYP.	MAX.	Unit	
$\overline{\text{SCK}}$ cycle time	t <sub>KCY2</sub>	V <sub>DD</sub> = 4.5 to 6.0 V	800			ns	
			3200			ns	
$\overline{\text{SCK}}$ high, low level width	t <sub>KL2</sub> t <sub>KH2</sub>	V <sub>DD</sub> = 4.5 to 6.0 V	400			ns	
			1600			ns	
SI setup time (to $\overline{\text{SCK}}$ ↑)	t <sub>SIK2</sub>		100			ns	
SI hold time (from $\overline{\text{SCK}}$ ↑)	t <sub>KSI2</sub>		400			ns	
$\overline{\text{SCK}}$ ↓ → SO output delay time	t <sub>KSO2</sub>	R <sub>L</sub> = 1 kΩ, <b>Note</b> C <sub>L</sub> = 100 pF	V <sub>DD</sub> = 4.5 to 6.0 V	0		300	ns
				0		1000	ns

**Note** R<sub>L</sub> and C<sub>L</sub> are output line load resistance and load capacitance, respectively.

**SBI mode ( $\overline{\text{SCK}}$  - internal clock output (master))**

Parameter	Symbol	Test conditions	MIN.	TYP.	MAX.	Unit
$\overline{\text{SCK}}$ cycle time	t <sub>KCY3</sub>	V <sub>DD</sub> = 4.5 to 6.0 V	1600			ns
			3800			ns
$\overline{\text{SCK}}$ high, low level width	t <sub>KL3</sub> t <sub>KH3</sub>	V <sub>DD</sub> = 4.5 to 6.0 V	t <sub>KCY3</sub> /2-50			ns
			t <sub>KCY3</sub> /2-150			ns
SB0, SB1 setup time (to $\overline{\text{SCK}}$ ↑)	t <sub>SIK3</sub>		150			ns
SB0, SB1 hold time (from $\overline{\text{SCK}}$ ↑)	t <sub>KSI3</sub>		t <sub>KCY3</sub> /2			ns
$\overline{\text{SCK}}$ ↓ → SB0, SB1 output delay time	t <sub>KSO3</sub>	R <sub>L</sub> = 1 kΩ, C <sub>L</sub> = 100 pF <b>Note</b> V <sub>DD</sub> = 4.5 to 6.0 V	0		250	ns
			0		1000	ns
$\overline{\text{SCK}}$ ↑ → SB0, 1 ↓	t <sub>KSB</sub>		t <sub>KCY3</sub>			ns
SB0, 1 ↓ → $\overline{\text{SCK}}$	t <sub>SBK</sub>		t <sub>KCY3</sub>			ns
SB0, SB1 low level width	t <sub>SBL</sub>		t <sub>KCY3</sub>			ns
SB0, SB1 high level width	t <sub>SBH</sub>		t <sub>KCY3</sub>			ns

**SBI mode ( $\overline{\text{SCK}}$  - external clock input (slave))**

Parameter	Symbol	Test conditions	MIN.	TYP.	MAX.	Unit
$\overline{\text{SCK}}$ cycle time	t <sub>KCY4</sub>	V <sub>DD</sub> = 4.5 to 6.0 V	800			ns
			3200			ns
$\overline{\text{SCK}}$ high, low level width	t <sub>KL4</sub> t <sub>KH4</sub>	V <sub>DD</sub> = 4.5 to 6.0 V	400			ns
			1600			ns
SB0, SB1 setup time (to $\overline{\text{SCK}}$ ↑)	t <sub>SIK4</sub>		100			ns
SB0, SB1 hold time (from $\overline{\text{SCK}}$ ↑)	t <sub>KSI4</sub>		t <sub>KCY4</sub> /2			ns
$\overline{\text{SCK}}$ ↓ → SB0, SB1 output delay time	t <sub>KSO4</sub>	R <sub>L</sub> = 1 kΩ, C <sub>L</sub> = 100 pF <b>Note</b> V <sub>DD</sub> = 4.5 to 6.0 V	0		300	ns
			0		1000	ns
$\overline{\text{SCK}}$ ↑ → SB0, 1 ↓	t <sub>KSB</sub>		t <sub>KCY4</sub>			ns
SB0, 1 ↓ → $\overline{\text{SCK}}$ ↓	t <sub>SBK</sub>		t <sub>KCY4</sub>			ns
SB0, SB1 low level width	t <sub>SBL</sub>		t <sub>KCY4</sub>			ns
SB0, SB1 high level width	t <sub>SBH</sub>		t <sub>KCY4</sub>			ns

**Note** R<sub>L</sub> and C<sub>L</sub> are SB0, SB1 output line load resistance and load capacitance, respectively.

**A/D converter** ( $T_a = -40$  to  $+70$  °C,  $V_{DD} = 2.7$  to  $6.0$  V,  $AV_{SS} = V_{SS} = 0$  V)

Parameter	Symbol	Test conditions	MIN.	TYP.	MAX.	Unit
Resolution			8	8	8	bit
Absolute accuracy <sup>Note 1</sup>		$2.5\text{ V} \leq AV_{REF+} \leq AV_{DD}$	$-10 \leq T_a \leq +70$ °C		$\pm 1.5$	LSB
			$-40 \leq T_a < -10$ °C		$\pm 2.0$	
Conversion time <sup>Note 2</sup>	$t_{CONV}$				$168/f_x$	μs
Sampling time <sup>Note 3</sup>	$t_{SAMP}$				$44/f_x$	μs
Analog input voltage	$V_{IAN}$		$AV_{REF-}$		$AV_{REF+}$	V
Analog supply voltage	$AV_{DD}$		2.5		$V_{DD}$	V
Reference input voltage <sup>Note 4</sup>	$AV_{REF+}$	$2.5\text{ V} \leq (AV_{REF+}) - (AV_{REF-})$	2.5		$AV_{DD}$	V
Reference input voltage <sup>Note 4</sup>	$AV_{REF-}$	$2.5\text{ V} \leq (AV_{REF+}) - (AV_{REF-})$	0		1.0	V
Analog input impedance	$R_{AN}$			1000		MΩ
$AV_{REF}$ current	$I_{REF}$			0.25	2.0	mA

- Note 1.** Absolute accuracy from which quantization error ( $\pm 1/2$  LSB) is removed.
2. Time until conversion end ( $EOC = 1$ ) after conversion start instruction execution ( $40.1\ \mu\text{s}$ : During  $f_x = 4.19$  MHz operation).
  3. Time until sampling end after conversion start instruction execution ( $10.5\ \mu\text{s}$ : During  $f_x = 4.19$  MHz operation).
  4.  $(AV_{REF+}) - (AV_{REF-})$  must be more than 2.5 V.

**AC timing test points (Except X1, XT1)**

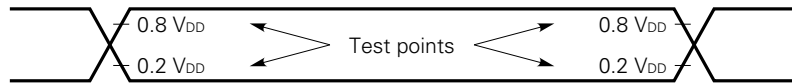

**Clock timing**

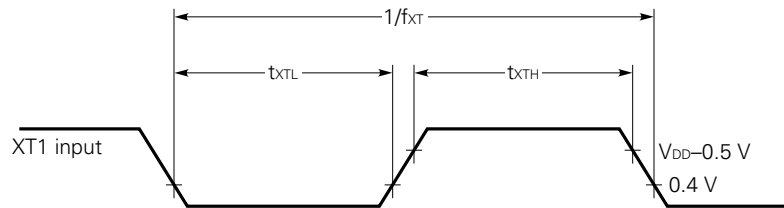
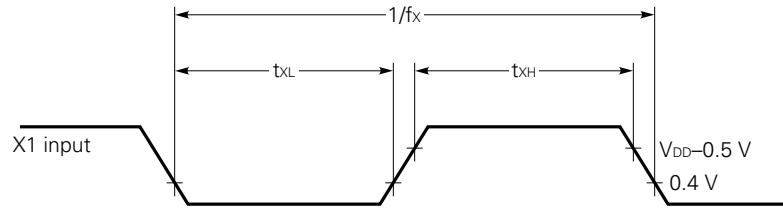

**TIO timing**

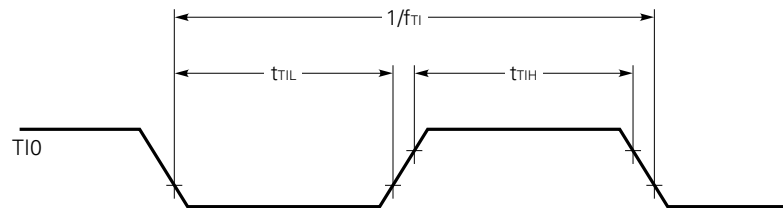

**Serial transfer timing**

**Serial I/O made (3-wire)**

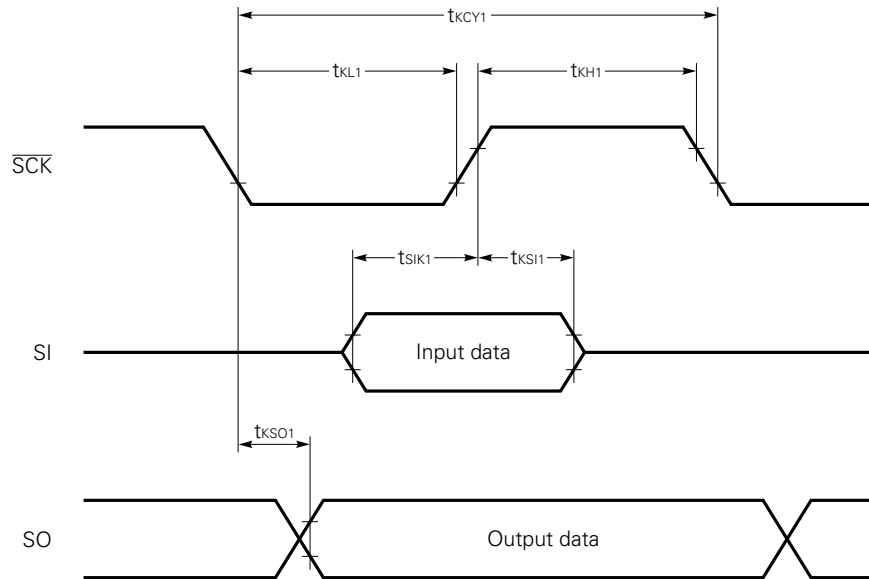

**Serial I/O mode (2-wire)**

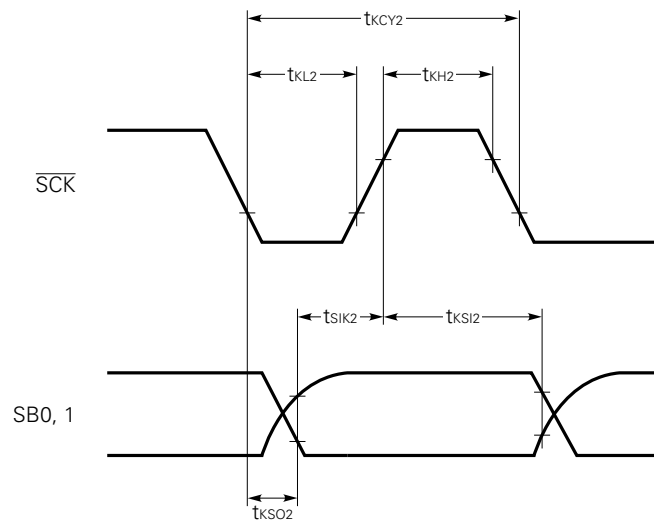



Serial transfer timing

SBI mode bus release signal transfer timing

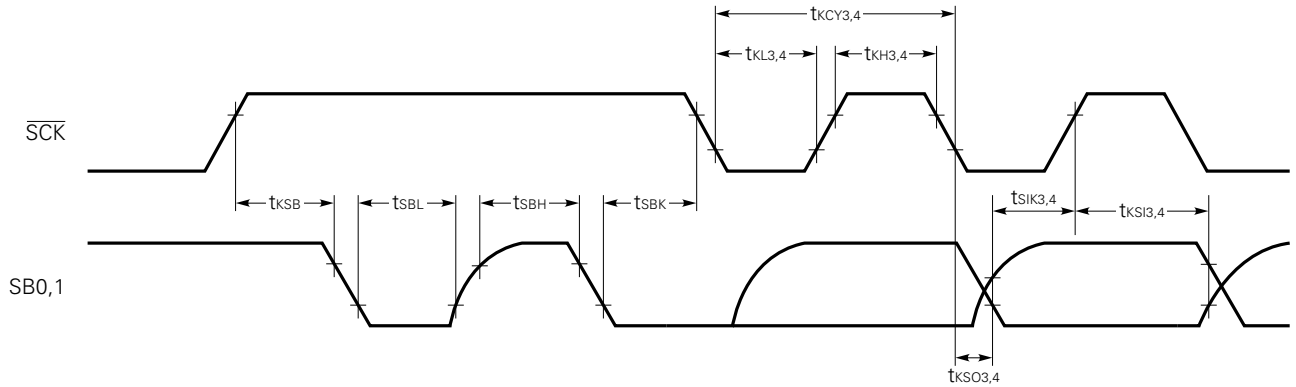

SBI mode command signal transfer timing

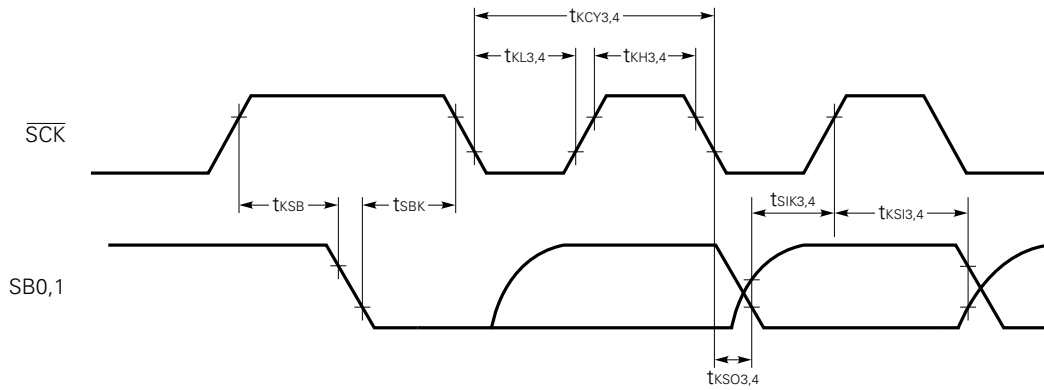

Interrupt input timing

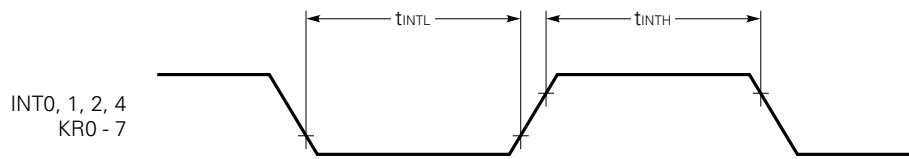

RESET input timing

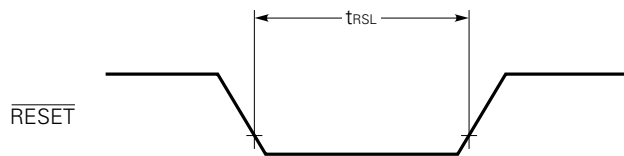

**Data memory STOP mode low voltage data retention characteristics (T<sub>a</sub> = -40 to +70 °C)**

Parameter	Symbol	Conditions	MIN.	TYP.	MAX.	Unit
Data retention voltage	V <sub>DDDR</sub>		2.0		6.0	V
Data retention current <b>Note 1</b>	I <sub>DDDR</sub>	V <sub>DDDR</sub> = 2.0 V		0.1	10	μA
Release signal SET time	t <sub>SREL</sub>		0			μs
Oscillation stabilization time <b>Note 2</b>	t <sub>WAIT</sub>	Release by RESET input		2 <sup>17</sup> /f <sub>x</sub>		ms
		Release by interrupt request		<b>Note 3</b>		ms

**Note 1.** On-chip pull-up resistor current is not included in this table.

**2.** The oscillation stabilization WAIT time is the time during which the CPU operation is stopped to prevent unstable operation when oscillation is started.

**3.** The WAIT time depends on the setting of the basic interval timer mode register (BTM) according to the following table.

BTM3	BTM2	BTM1	BTM0	WAIT time (f <sub>x</sub> = 4.19 MHz)
-	0	0	0	2 <sup>20</sup> /f <sub>x</sub> (approx. 250 ms)
-	0	1	1	2 <sup>17</sup> /f <sub>x</sub> (approx. 31.3 ms)
-	1	0	1	2 <sup>15</sup> /f <sub>x</sub> (approx. 7.82 ms)
-	1	1	1	2 <sup>13</sup> /f <sub>x</sub> (approx. 1.95 ms)

**Data retention timing (STOP mode is released by RESET input)**

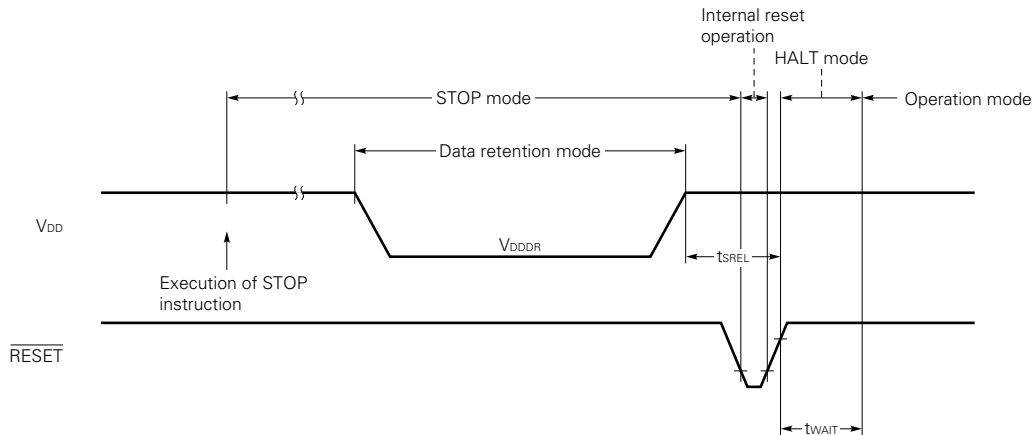

**Data retention timing (Standby release signal: STOP mode is released by interrupt signal)**

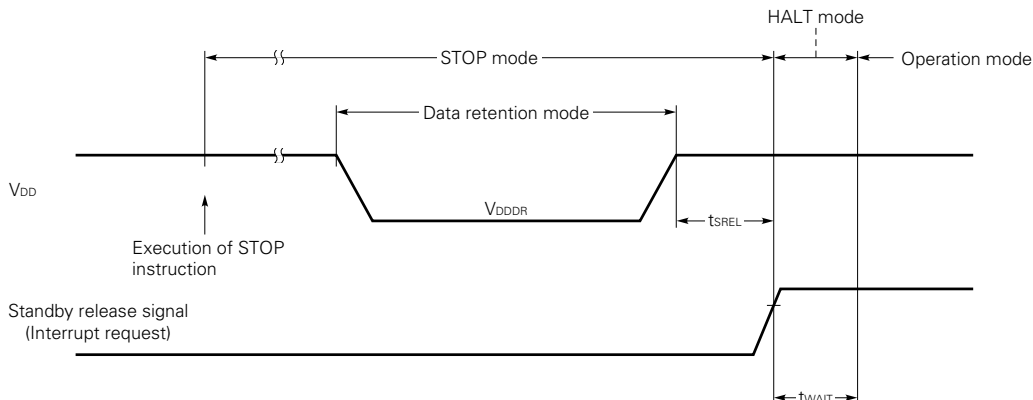

11. CHARACTERISTIC CURVES (FOR REFERENCE ONLY)

★

I<sub>DD</sub> vs. V<sub>DD</sub> (Main system clock: 4.19 MHz, crystal resonator)

(T<sub>a</sub>=25°C)

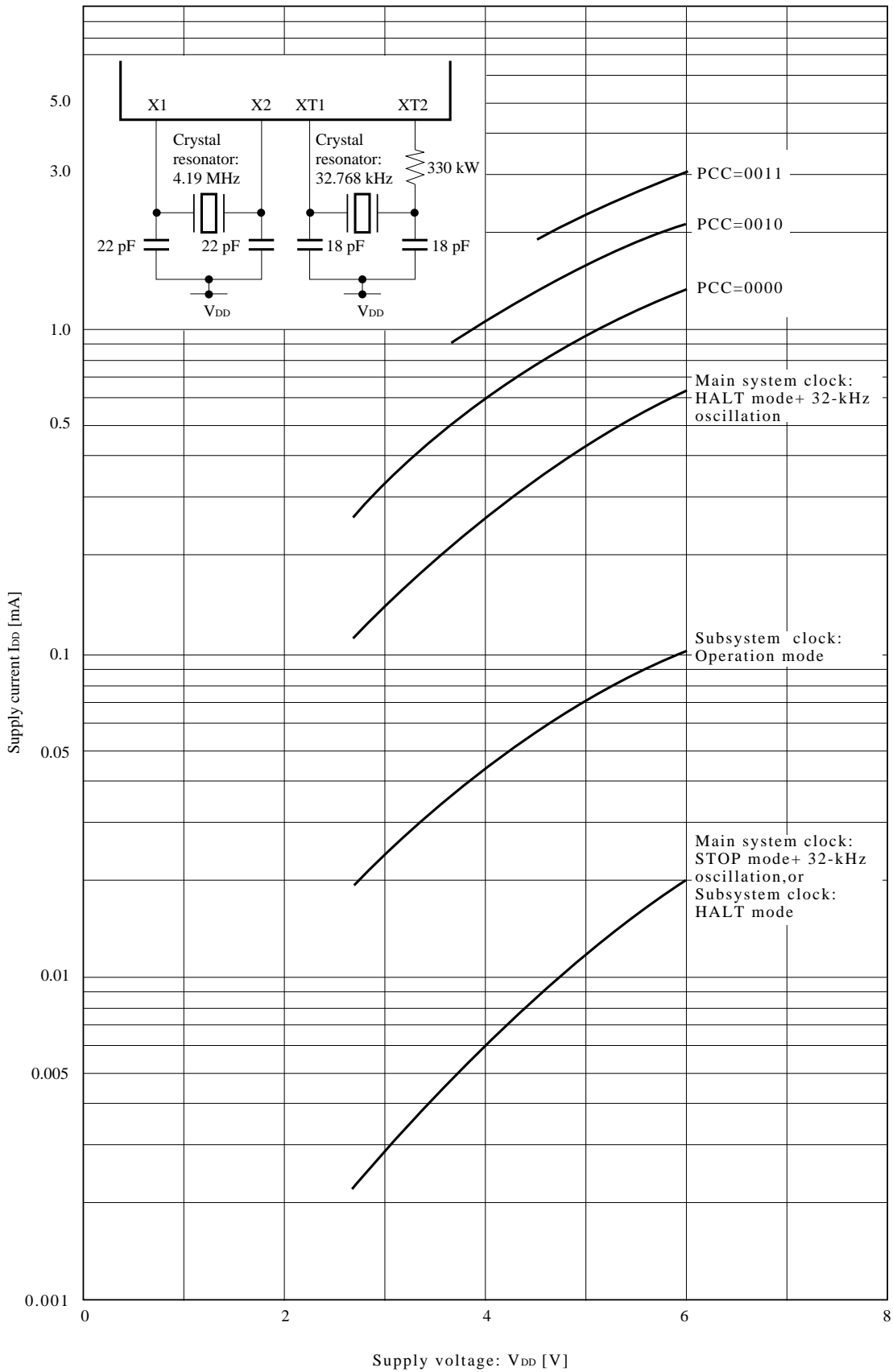

I<sub>DD</sub> vs. V<sub>DD</sub> (Main system clock: 2.0 MHz, crystal resonator)

(T<sub>a</sub>=25°C)

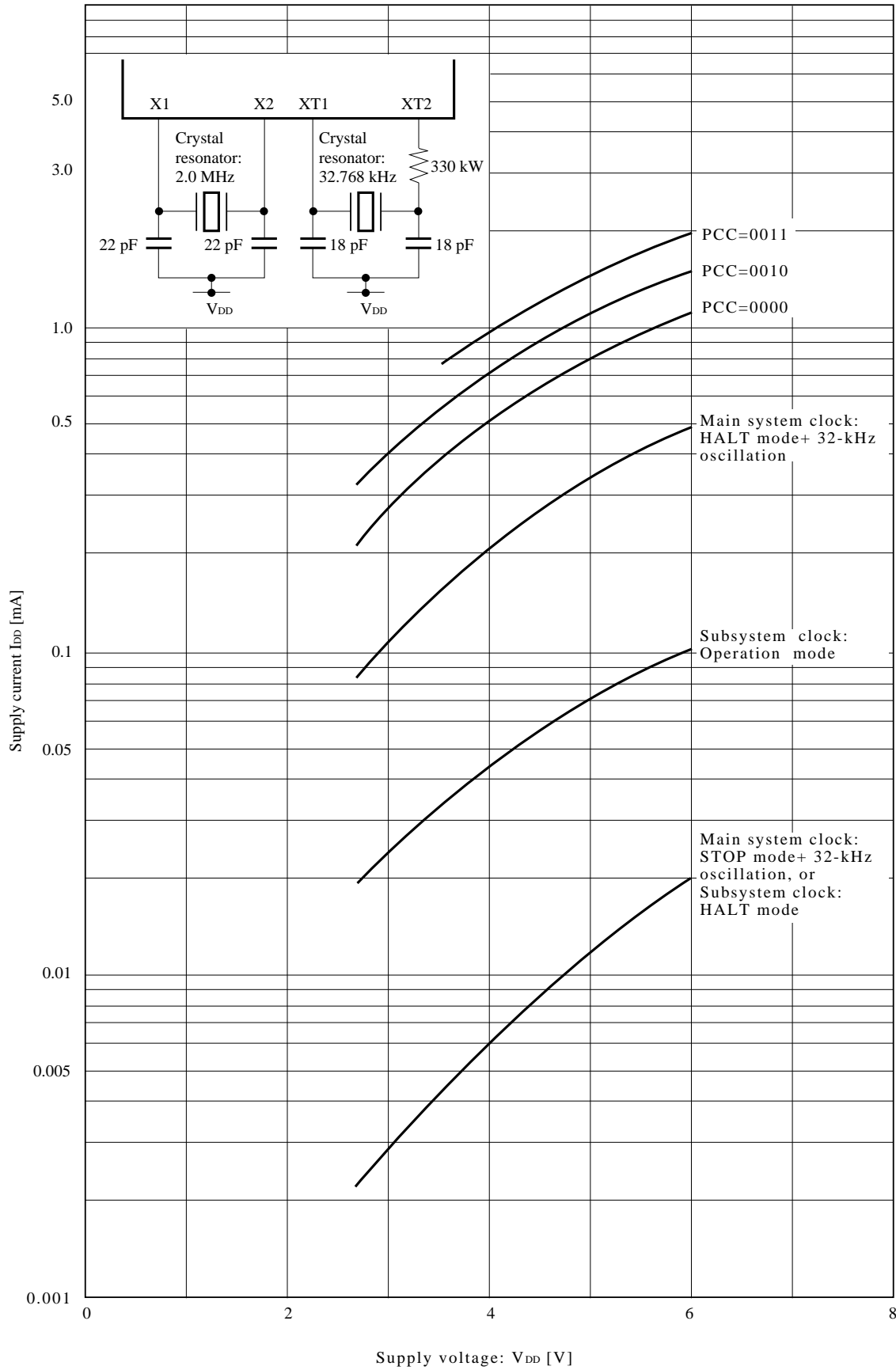

**I<sub>DD</sub> vs. V<sub>DD</sub> (Main system clock: 4.19 MHz, ceramic resonator)**

(T<sub>a</sub>=25°C)

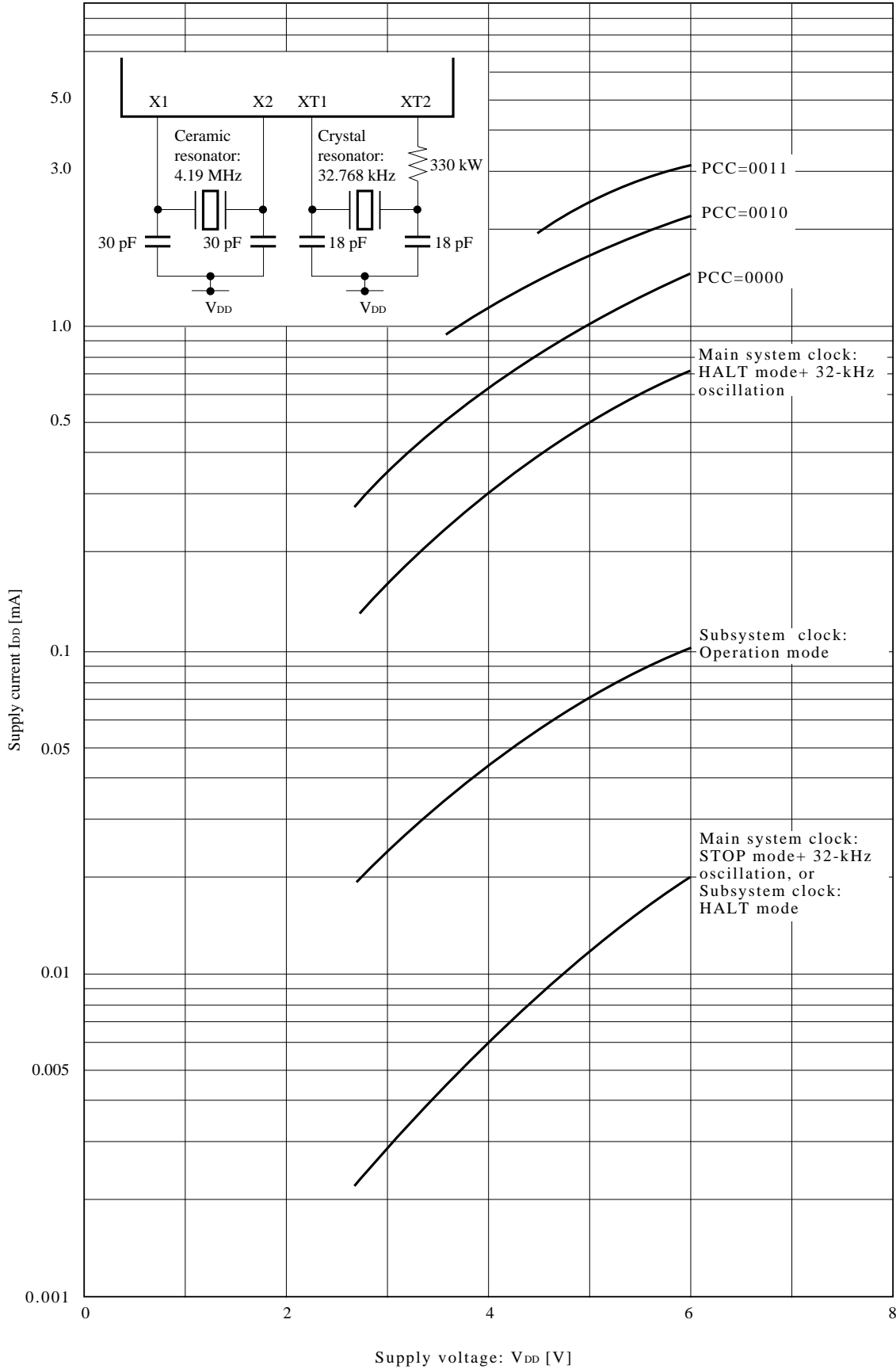

I<sub>DD</sub> vs. V<sub>DD</sub> (Main system clock: 2.0 MHz, ceramic resonator)

(T<sub>a</sub>=25°C)

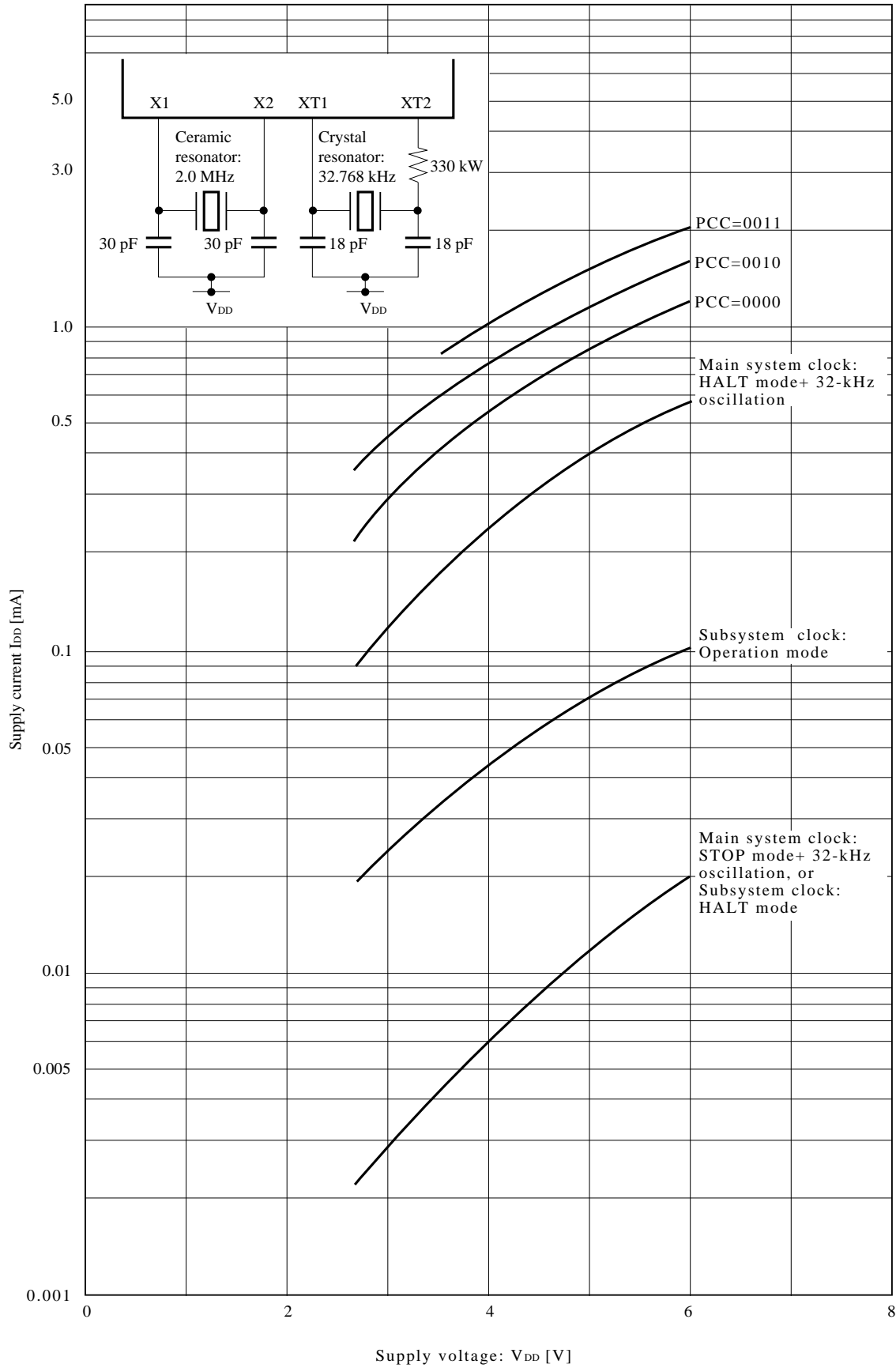

I<sub>DD</sub> vs. f<sub>x</sub>

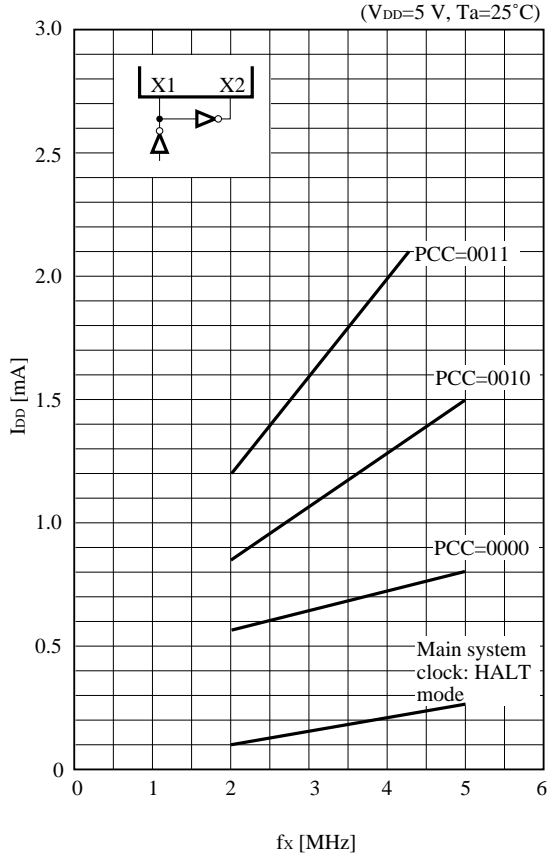

I<sub>DD</sub> vs. f<sub>x</sub>

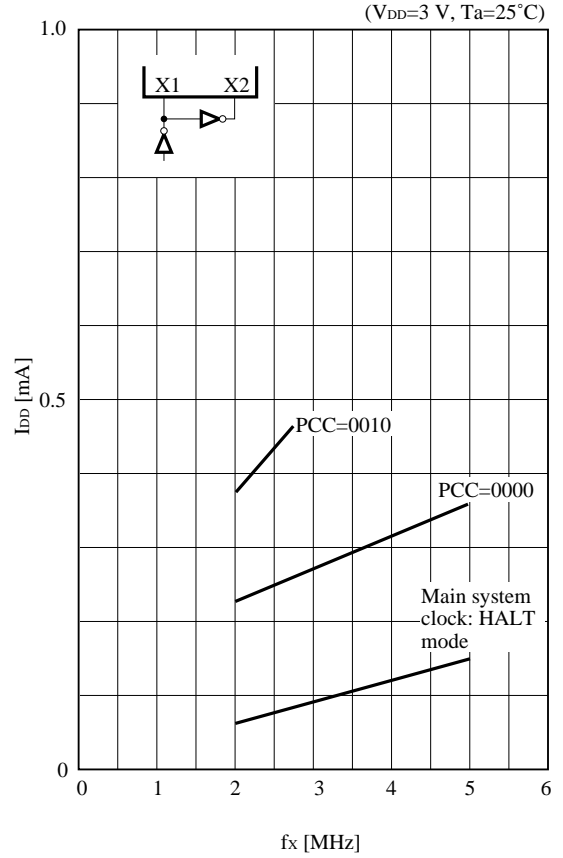

I<sub>OL</sub> vs. V<sub>OL</sub> (Port 0)

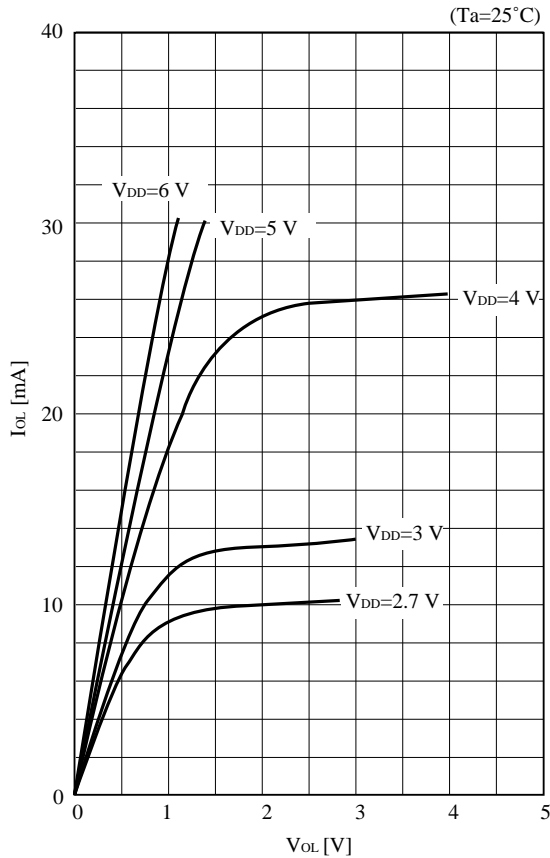

I<sub>OL</sub> vs. V<sub>OL</sub> (Port 2, 6 through 10)

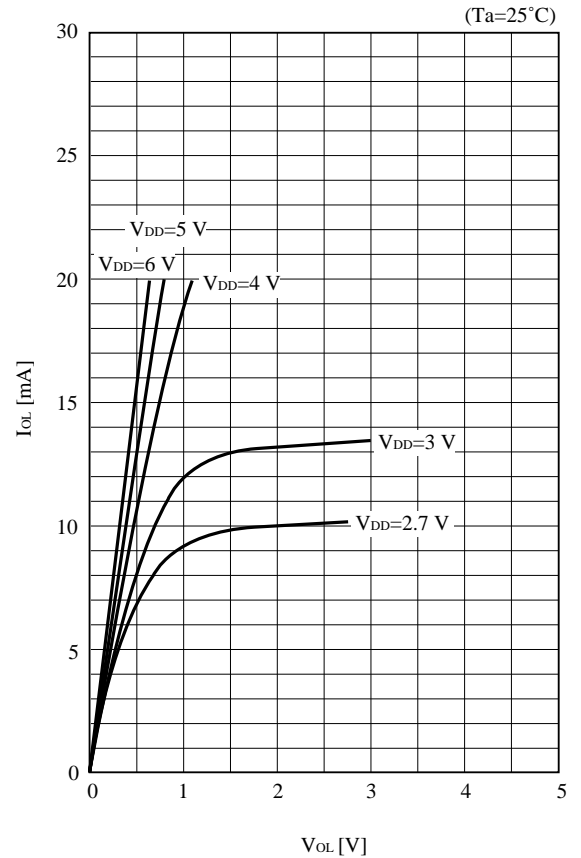

**I<sub>OL</sub> vs. V<sub>OL</sub> (Port 3)**

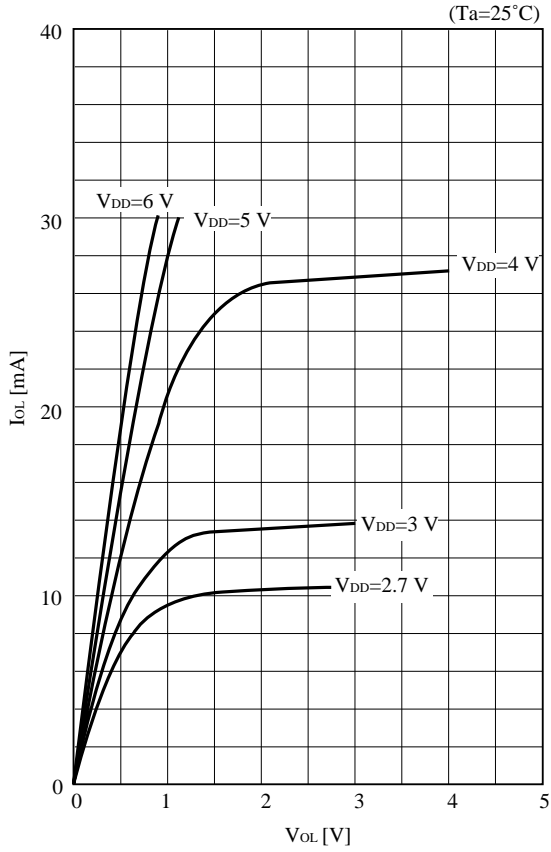

**I<sub>OL</sub> vs. V<sub>OL</sub> (Port 4, 5)**

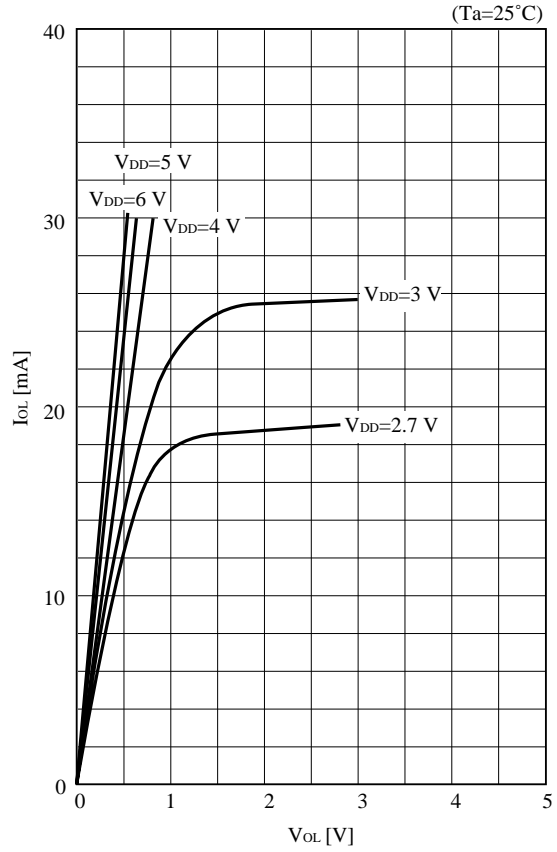

**I<sub>OH</sub> vs. V<sub>OH</sub>**

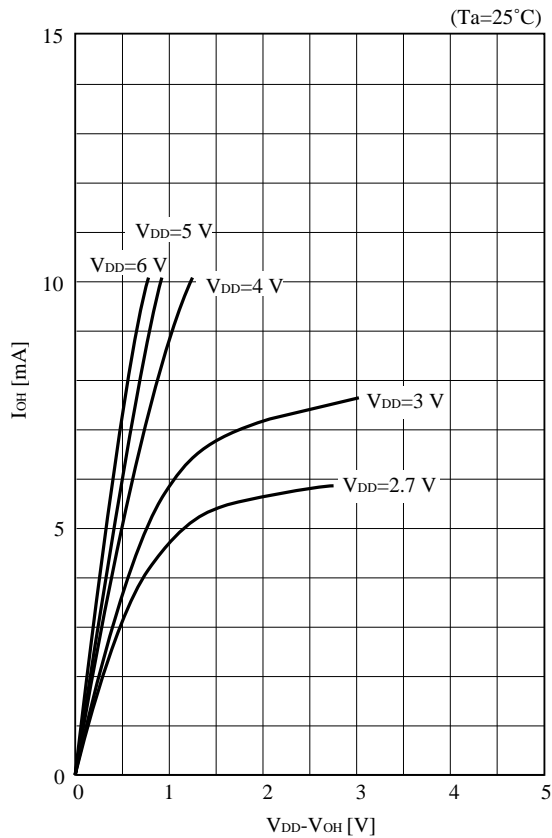



12. PACKAGE DRAWINGS

64 PIN PLASTIC SHRINK DIP (750 mil)

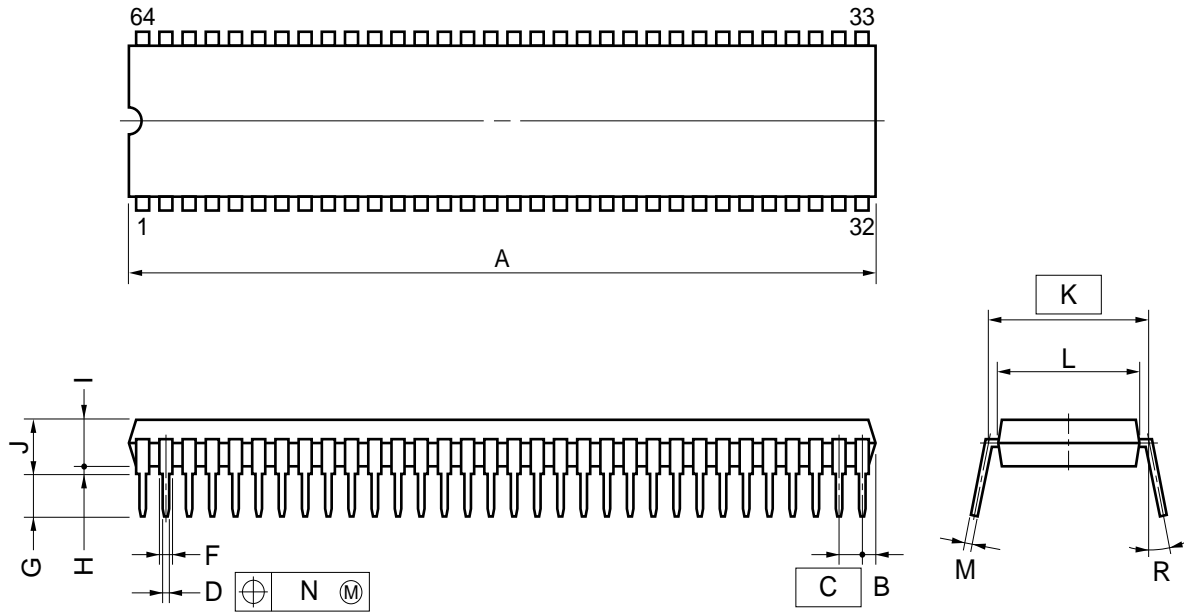

**NOTE**

- 1) Each lead centerline is located within 0.17 mm (0.007 inch) of its true position (T.P.) at maximum material condition.
- 2) Item "K" to center of leads when formed parallel.

ITEM	MILLIMETERS	INCHES
A	58.68 MAX.	2.311 MAX.
B	1.78 MAX.	0.070 MAX.
C	1.778 (T.P.)	0.070 (T.P.)
D	0.50±0.10	0.020 <sup>+0.004</sup> <sub>-0.005</sub>
F	0.9 MIN.	0.035 MIN.
G	3.2±0.3	0.126±0.012
H	0.51 MIN.	0.020 MIN.
I	4.31 MAX.	0.170 MAX.
J	5.08 MAX.	0.200 MAX.
K	19.05 (T.P.)	0.750 (T.P.)
L	17.0	0.669
M	0.25 <sup>+0.10</sup> <sub>-0.05</sub>	0.010 <sup>+0.004</sup> <sub>-0.003</sub>
N	0.17	0.007
R	0~15°	0~15°

P64C-70-750A,C-1

64 PIN PLASTIC QFP (□14)

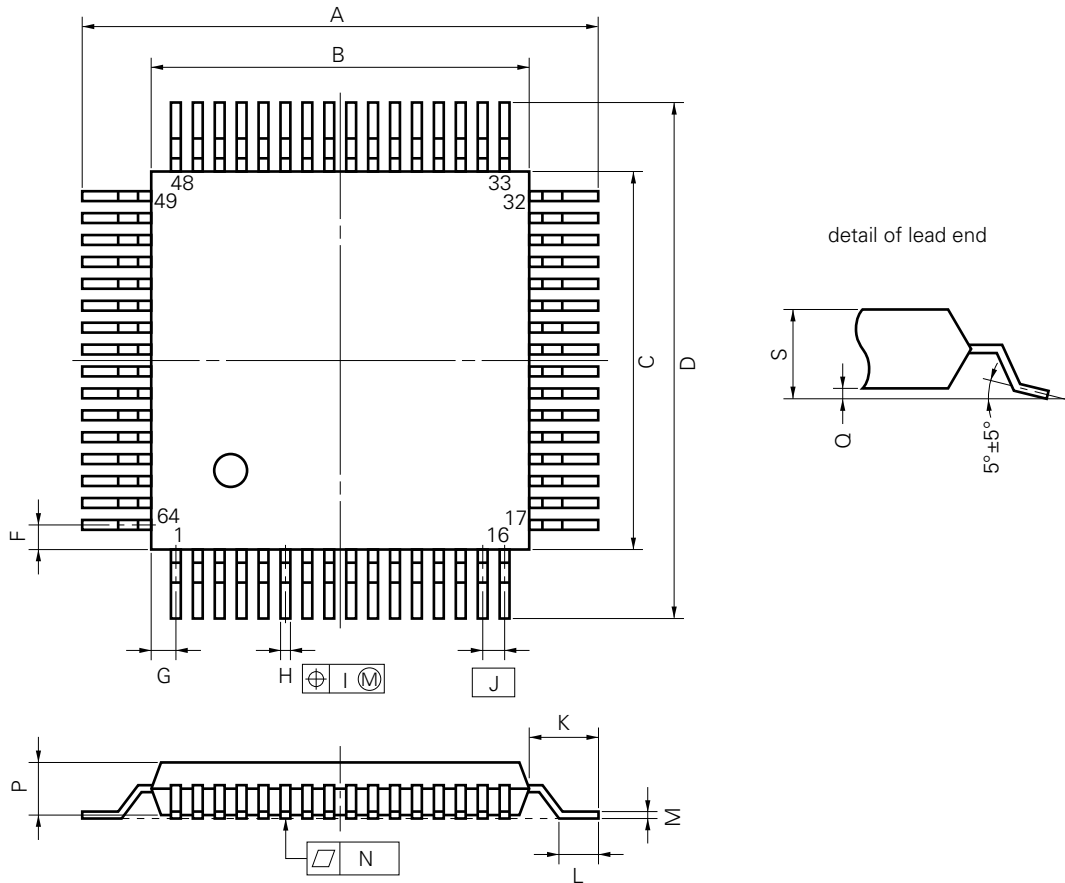

P64GC-80-AB8-2

**NOTE**

Each lead centerline is located within 0.15 mm (0.006 inch) of its true position (T.P.) at maximum material condition.

ITEM	MILLIMETERS	INCHES
A	17.6±0.4	0.693±0.016
B	14.0±0.2	0.551 <sup>+0.009</sup> <sub>-0.008</sub>
C	14.0±0.2	0.551 <sup>+0.009</sup> <sub>-0.008</sub>
D	17.6±0.4	0.693±0.016
F	1.0	0.039
G	1.0	0.039
H	0.35±0.10	0.014 <sup>+0.004</sup> <sub>-0.005</sub>
I	0.15	0.006
J	0.8 (T.P.)	0.031 (T.P.)
K	1.8±0.2	0.071±0.008
L	0.8±0.2	0.031 <sup>+0.009</sup> <sub>-0.008</sub>
M	0.15 <sup>+0.10</sup> <sub>-0.05</sub>	0.006 <sup>+0.004</sup> <sub>-0.003</sub>
N	0.15	0.006
P	2.55	0.100
Q	0.1±0.1	0.004±0.004
S	2.85 MAX.	0.112 MAX.

**13. RECOMMENDED SOLDERING CONDITIONS**

The following conditions (See table below) must be met when soldering this product.

Please consult with our sales offices in case other soldering process is used, or in case soldering is done under different conditions.

For more details, refer to our document “SEMICONDUCTOR DEVICE MOUNTING TECHNOLOGY MANUAL” (IEI-1207).

**Table 13-1 Type of Surface Mount Device**

μPD75028GC-xxx-AB8: 64-pin plastic QFP (□ 14 mm)

Soldering Process	Soldering Conditions	Symbol
Wave Soldering	Solder temperature: 260 °C or lower, Flow time: 10 seconds or less, Exposure limit <b>Note</b> : 7 days (10 hours pre-baking is required at 125 °C afterwards) Temperature of pre-heat: 120 °C or lower (Package surface temperature) Number of flow process: 1	WS60-107-1
Infrared Ray Reflow	Peak temperature of package surface: 230 °C or lower Reflow time: 30 seconds or less (210 °C or higher), Number or reflow process: 1 Exposure limit <b>Note</b> : 7 days (10 hours pre-baking is required at 125 °C afterwards)	IR30-107-1
VPS	Peak temperature of package surface: 215 °C or lower Reflow time: 40 seconds or less (200 °C or higher), Number of reflow process: 1 Exposure limit <b>Note</b> : 7 days (10 hours pre-baking is required at 125 °C afterwards)	VP15-107-1
Partial Heating Method	Pin temperature: 300 °C or lower, Time: 3 seconds or less (Per side of the package)	—

**Note** Exposure limit before soldering after dry-pack package is opened. Storage conditions: 25 °C and relative humidity at 65 % or less.

**Caution** Do not apply more than one soldering method at any one time, except for “Partial heating method”.

**Table 13-2 Type of Through Hole Device**

μPD75028CW-xxx: 64-pin plastic shrink DIP (750 mil)

Soldering Process	Soldering Conditions
Wave Soldering	Solder temperature: 260 °C or lower, Flow time: 10 seconds or less
Partial Heating Method	Pin temperature: 260 °C or lower, Time: 10 seconds or less

**Caution** Do not jet molten solder on the surface of package.

**PRODUCT NEWS**

A product whose recommended soldering conditions have been improved is available. (Improvements: Expansion of infrared ray reflow soldering peak temperature (235 °C), two sessions of soldering, extended term of storage, etc.)  
For details, contact our sales staff.

**APPENDIX A. DEVELOPMENT TOOLS**

The following development tools are provided for the development of a system which employs the μPD75028.

Hardware	IE-75000-R <sup>Note 1</sup> IE-75001-R	In-circuit emulator for 75X series
	IE-75000-R-EM <sup>Note 2</sup>	Emulation board for IE-75000-R and IE-75001-R
	EP-75028CW-R	Emulation probe for μPD75028CW
	EP-75028GC-R EV-9200GC-64	Emulation probe for μPD75028GC with the 64-pin conversion socket EV-9200GC-64
	PG-1500	
	PA-75P036CW	PROM programmer adapter for μPD75P036CW. Connected to PG-1500.
	PA-75P036GC	PROM programmer adapter for μPD75P036GC. Connected to PG-1500.
	Software	IE control program
PG-1500 controller		
RA75X relocatable assembler		

- Note**
1. Available for maintenance purpose only.
  2. Not included with IE-75001-R.
  3. Ver. 5.00/5.00A has a task swap function. However, it cannot be used for these software programs.

**Remark** For development tools available from third parties, please refer to "75X Series Selection Guide (IF-xxx)."

**APPENDIX B. RELATED DOCUMENTS**

★

**List of documents related to devices**

Document	Document No.
User's Manual	IEU-694
Instruction Table	IEM-5511
Application Note	IEA-689
75X Series Selection Guide	IF-151

**List of documents related to development tools**

Document		Document No.	
Hardware	IE-75000-R/IE-75001-R User's Manual	EEU-846	
	IE-75000-R-EM User's Manual	EEU-673	
	EP-75028CW-R User's Manual	EEU-697	
	EP-75028GC-R User's Manual	EEU-692	
	PG-1500 User's Manual	EEU-651	
Software	RA75X Assembler Package User's Manual	Operation	EEU-731
		Language	EEU-730
	PG-1500 Controller User's Manual	EEU-704	

**Other documents**

Document	Document No.
Package Manual	IEI-635
Semiconductor Device Mounting Technology Manual	IEI-616
NEC Semiconductor Device Quality Grades	IEI-620
NEC Semiconductor Device Reliability and Quality Control	IEM-5068
About Electrostatic Discharge (ESD) Test	MEM-539
Semiconductor Device Quality Assurance Guide	MEI-603
Microcomputer-Related Product Guide: Third Parties' Products	MEI-604

**Remark** The document numbers are those of Japanese-version documents.

**Caution** The above documents are subject to change without notice. Be sure to use the latest documents for design or for any other similar purpose.

[MEMO]

## NOTES FOR CMOS DEVICES

**① PRECAUTION AGAINST ESD FOR SEMICONDUCTORS**

Note:

Strong electric field, when exposed to a MOS device, can cause destruction of the gate oxide and ultimately degrade the device operation. Steps must be taken to stop generation of static electricity as much as possible, and quickly dissipate it once, when it has occurred. Environmental control must be adequate. When it is dry, humidifier should be used. It is recommended to avoid using insulators that easily build static electricity. Semiconductor devices must be stored and transported in an anti-static container, static shielding bag or conductive material. All test and measurement tools including work bench and floor should be grounded. The operator should be grounded using wrist strap. Semiconductor devices must not be touched with bare hands. Similar precautions need to be taken for PW boards with semiconductor devices on it.

**② HANDLING OF UNUSED INPUT PINS FOR CMOS**

Note:

No connection for CMOS device inputs can be cause of malfunction. If no connection is provided to the input pins, it is possible that an internal input level may be generated due to noise, etc., hence causing malfunction. CMOS devices behave differently than Bipolar or NMOS devices. Input levels of CMOS devices must be fixed high or low by using a pull-up or pull-down circuitry. Each unused pin should be connected to  $V_{DD}$  or GND with a resistor, if it is considered to have a possibility of being an output pin. All handling related to the unused pins must be judged device by device and related specifications governing the devices.

**③ STATUS BEFORE INITIALIZATION OF MOS DEVICES**

Note:

Power-on does not necessarily define initial status of MOS device. Production process of MOS does not define the initial operation status of the device. Immediately after the power source is turned ON, the devices with reset function have not yet been initialized. Hence, power-on does not guarantee out-pin levels, I/O settings or contents of registers. Device is not initialized until the reset signal is received. Reset operation must be executed immediately after power-on for devices having reset function.

No part of this document may be copied or reproduced in any form or by any means without the prior written consent of NEC Corporation. NEC Corporation assumes no responsibility for any errors which may appear in this document.

NEC Corporation does not assume any liability for infringement of patents, copyrights or other intellectual property rights of third parties by or arising from use of a device described herein or any other liability arising from use of such device. No license, either express, implied or otherwise, is granted under any patents, copyrights or other intellectual property rights of NEC Corporation or others.

The devices listed in this document are not suitable for use in aerospace equipment, submarine cables, nuclear reactor control systems and life support systems. If customers intend to use NEC devices for above applications or they intend to use "Standard" quality grade NEC devices for applications not intended by NEC, please contact our sales people in advance.

Application examples recommended by NEC Corporation

Standard: Computer, Office equipment, Communication equipment, Test and Measurement equipment, Machine tools, Industrial robots, Audio and Visual equipment, Other consumer products, etc.

Special: Automotive and Transportation equipment, Traffic control systems, Antidisaster systems, Anticrime systems, etc.

M4 92.6

**MS-DOS is a trademark of Microsoft Corporation.**

**PC/AT and PC DOS are trademarks of IBM Corporation.**