

TP65H150G4LSGBE

650V SuperGaN® GaN FET in PQFN (source tab)

Description

The TP65H150G4LSGBE 650V, 150mΩ Gallium Nitride (GaN) FET is a normally-off device using Renesas' Gen IV platform. It combines a state-of-the-art high voltage GaN HEMT with a low voltage silicon MOSFET to offer superior reliability and performance.

The Gen IV SuperGaN® platform uses advanced epi and patented design technologies to simplify manufacturability while improving efficiency over silicon via lower gate charge, output capacitance, crossover loss, and reverse recovery charge.

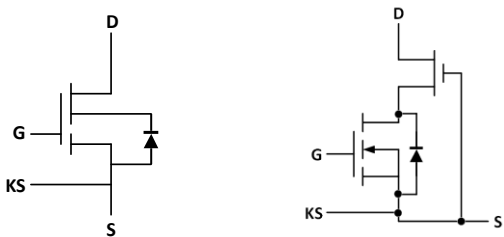
Benefits

- Achieves increased efficiency in both hard- and soft-switched circuits
  - Increased power density
  - Reduced system size and weight
  - Overall lower system cost
- Easy to drive with commonly used gate drivers

Product/Schematic Diagrams



TP70H150G4LSGBE PQFN



Cascode Schematic Symbol

Cascode Device Structure

Features

- Gen IV technology
- JEDEC-qualified GaN technology
- Dynamic  $R_{DS(on)eff}$  production tested
- Robust design, defined by
  - Transient over-voltage capability
  - Operation with E-mode Gate drivers without need for Zener protection.
- Very low  $Q_{RR}$
- Reduced crossover loss
- RoHS compliant and Halogen-free packaging

Applications

- Consumer
- Power adapters
- Low power SMPS
- Lighting



Specifications

$V_{DS}$ (V)	650
$V_{DSS(TR)}$ (V) maximum	800
$R_{DS(on)}$ (mΩ) maximum <sup>[1]</sup>	180
$Q_{OSS}$ (nC) typical	35
$Q_G$ (nC) typical	14

1. Dynamic  $R_{DS(on)}$ ; see Figure 21 and Figure 22.

## Contents

<b>1. Pin Information</b>	<b>3</b>
1.1 Pin Assignments	3
1.2 Pin Descriptions	3
<b>2. Specifications</b>	<b>4</b>
2.1 Absolute Maximum Ratings	4
2.2 Thermal Specifications	4
2.3 Circuit Implementation	5
2.4 Electrical Specifications – Forward Device	6
2.5 Electrical Specifications – Reverse Device	7
<b>3. Typical Performance Graphs</b>	<b>8</b>
<b>4. Test Circuits and Waveforms</b>	<b>12</b>
<b>5. Package Outline Drawings</b>	<b>13</b>
<b>6. Design Considerations</b>	<b>14</b>
<b>7. Related Information</b>	<b>14</b>
<b>8. Ordering Information</b>	<b>14</b>
<b>9. Revision History</b>	<b>14</b>

## Figures

Figure 1. Pin Assignments – Bottom View	3
Figure 2. Simplified Half-Bridge Schematic	5
Figure 3. Simplified Single-Ended Schematic	5
Figure 4. Typical Output Characteristics, $T_J = 25^\circ\text{C}$	8
Figure 5. Typical Output Characteristics, $T_J = 150^\circ\text{C}$	8
Figure 6. Typical Transfer Characteristics	8
Figure 7. Normalized On-resistance	8
Figure 8. Typical Capacitance	9
Figure 9. Typical $C_{OSS}$ Stored Energy	9
Figure 10. Typical $Q_{OSS}$	9
Figure 11. Typical Gate Charge	9
Figure 12. Power Dissipation	10
Figure 13. Current Derating	10
Figure 14. Forward Characteristics of Rev. Diode	10
Figure 15. Transient Thermal Resistance	10
Figure 16. Safe Operating Area $T_C = 25^\circ\text{C}$	11
Figure 17. Switching Time Test Circuit	12
Figure 18. Switching Time Waveform	12
Figure 19. Diode Characteristics Test Circuit	12
Figure 20. Diode Recovery Waveform	12
Figure 21. Dynamic $R_{DS(on)eff}$ Test Circuit	12
Figure 22. Dynamic $R_{DS(on)eff}$ Waveform	12

# 1. Pin Information

## 1.1 Pin Assignments

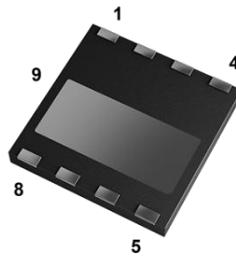


Figure 1. Pin Assignments – Bottom View

## 1.2 Pin Descriptions

Pin Number	Pin Name	Description
1, 2, 3, 4	D	Drain.
5, 6	S	Source.
7	KS	Kelvin source.
8	G	Gate.
9	S	Source.

## 2. Specifications

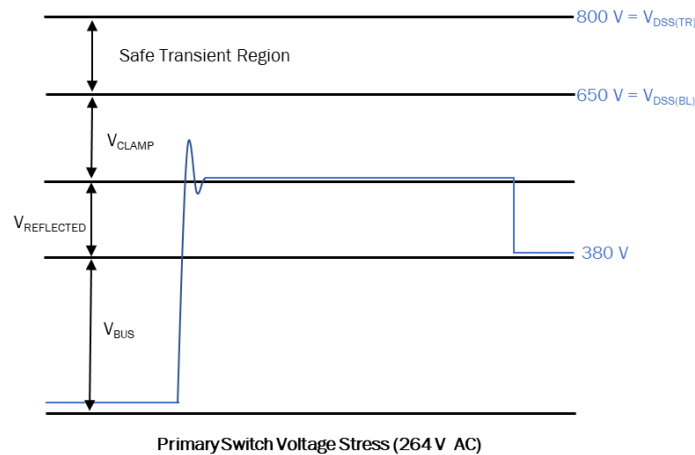
### 2.1 Absolute Maximum Ratings

$T_c = 25^\circ\text{C}$  unless otherwise stated.

**Caution:** Do not operate at or near the maximum ratings listed for extended periods of time. Exposure to such conditions can adversely impact product reliability and result in failures not covered by warranty.

Symbol	Parameter	Minimum	Maximum	Unit	
$V_{DSS}$	Drain to source voltage ( $T_J = -55^\circ\text{C}$ to $150^\circ\text{C}$ )	-	650	V	
$V_{DSS(TR), \text{non-repetitive}}$	Transient drain to source voltage, non-repetitive <sup>[1]</sup>	-	800		
$V_{DSS(TR), \text{repetitive}}$	Transient drain to source voltage, repetitive <sup>[2]</sup>	-	750		
$V_{GSS}$	Gate to source voltage	-20	+20		
$P_D$	Maximum power dissipation at $T_c = 25^\circ\text{C}$	-	62.5	W	
$I_D$	Continuous drain current at $T_c = 25^\circ\text{C}$ <sup>[3]</sup>	-	14.2	A	
	Continuous drain current at $T_c = 100^\circ\text{C}$ <sup>[3]</sup>	-	9	A	
$I_{DM}$	Pulsed drain current (pulse width: 10 $\mu\text{s}$ )	-	55	A	
$T_c$	Operating temperature	Case	-55	+150	$^\circ\text{C}$
$T_J$		Junction	-55	+150	$^\circ\text{C}$
$T_s$	Storage temperature	-55	+150	$^\circ\text{C}$	
$T_{SOLD}$	Reflow soldering temperature <sup>[4]</sup>	-	260	$^\circ\text{C}$	

1. In off-state, spike duration < 30 $\mu\text{s}$ , non-repetitive.
2. Off-state, spike duration < 5 $\mu\text{s}$ .
3. For increased stability at high current operation, see "Circuit Implementation".
4. Reflow MSL3.

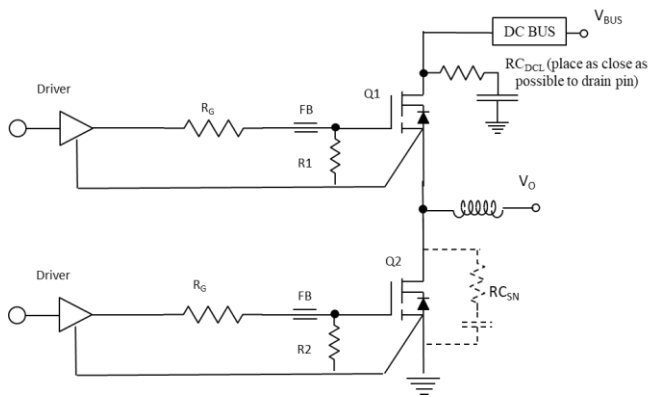


### 2.2 Thermal Specifications

Symbol	Condition	Typical Value	Unit
$R_{\theta JC}$	Junction-to-case	2	$^\circ\text{C}/\text{W}$
$R_{\theta JA}$	Junction-to-ambient <sup>[1]</sup>	50	

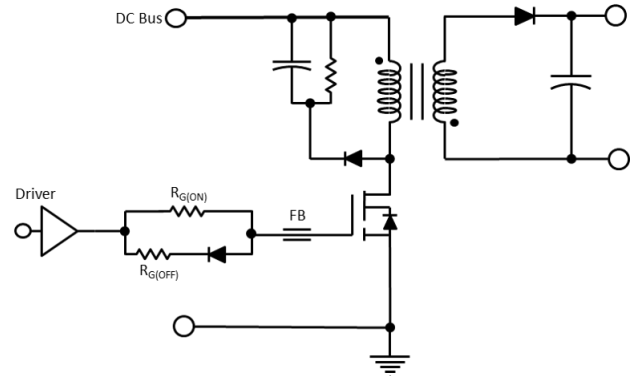
1. Device on one layer epoxy PCB for source connection (vertical and without air stream cooling, with 6cm<sup>2</sup> copper area and 70 $\mu\text{m}$  thickness).

## 2.3 Circuit Implementation



**Figure 2. Simplified Half-Bridge Schematic**

Recommended gate drive: (0V, 6V) with  $R_{G(\text{tot})} = 20\Omega$  <sup>[1]</sup>



**Figure 3. Simplified Single-Ended Schematic**

Recommended gate drive:

Gate drive: (0V, 6V):  $R_{G(\text{ON})} = 50$  to  $150\Omega$ ;  $R_{G(\text{OFF})} = 0$  to  $10\Omega$

Gate drive\*: (-6V, 6V):  $R_{G(\text{ON})} = 50$  to  $100\Omega$ ;  $R_{G(\text{OFF})} = 0$  to  $20\Omega$

Gate Ferrite Bead (FB1)	Recommended DC Link RC Snubber ( $RC_{DCL}$ ) <sup>[2]</sup>
120Ω at 100MHz	4.7nF + 5Ω

1. For bridge topologies only.  $R_G$  could be much smaller in single-ended topologies.
2.  $RC_{DCL}$  should be placed as close as possible to the drain pin.

For additional driver configurations/options, see application note [Recommended External Circuitry for Renesas GaN FETs](#).

## 2.4 Electrical Specifications – Forward Device

T<sub>J</sub> = 25°C unless otherwise stated.

Symbol	Parameter	Test Conditions	Minimum	Typical	Maximum	Unit
V <sub>DSS(BL)</sub>	Maximum drain-source voltage	V <sub>GS</sub> = 0V	650	-	-	V
V <sub>GS(th)</sub>	Gate threshold voltage	V <sub>DS</sub> = V <sub>GS</sub> , I <sub>D</sub> = 0.5mA	1.2	1.6	2	V
ΔV <sub>GS(th)</sub> /T <sub>J</sub>	Gate threshold voltage temperature coefficient		-	-5.8	-	mV/°C
R <sub>DS(on)eff</sub>	Drain-source on-resistance <sup>[1]</sup>	V <sub>GS</sub> = 6V, I <sub>D</sub> = 10A, T <sub>J</sub> = 25°C	-	150	180	mΩ
		V <sub>GS</sub> = 6V, I <sub>D</sub> = 10A, T <sub>J</sub> = 150°C	-	307	-	
I <sub>DSS</sub>	Drain-to-source leakage current	V <sub>DS</sub> = 650V, V <sub>GS</sub> = 0V, T <sub>J</sub> = 25°C	-	2.5	25	μA
		V <sub>DS</sub> = 650V, V <sub>GS</sub> = 0V, T <sub>J</sub> = 150°C	-	10	-	
I <sub>GSS</sub>	Gate-to-source forward leakage current	V <sub>GS</sub> = 20V	-	-	100	μA
	Gate-to-source reverse leakage current	V <sub>GS</sub> = -20V	-	-	-100	
C <sub>ISS</sub>	Input capacitance	V <sub>GS</sub> = 0V, V <sub>DS</sub> = 400V, f = 1MHz	-	1160	-	pF
C <sub>OSS</sub>	Output capacitance		-	28	-	
C <sub>RSS</sub>	Reverse transfer capacitance		-	2.8	-	
C <sub>O(er)</sub>	Output capacitance, energy related <sup>[2]</sup>	V <sub>GS</sub> = 0V, V <sub>DS</sub> = 0V to 400V	-	40	-	pF
C <sub>O(tr)</sub>	Output capacitance, time related <sup>[3]</sup>		-	77	-	
Q <sub>G</sub>	Total gate charge	V <sub>DS</sub> = 400V, V <sub>GS</sub> = 0V to 6V, I <sub>D</sub> = 10A	-	14	-	nC
Q <sub>GS</sub>	Gate-source charge		-	3	-	
Q <sub>GD</sub>	Gate-drain charge		-	5.2	-	
Q <sub>OSS</sub>	Output charge	V <sub>GS</sub> = 0V, V <sub>DS</sub> = 0V to 400V	-	35	-	nC
t <sub>D(on)</sub>	Turn-on delay	V <sub>DS</sub> = 400V, V <sub>GS</sub> = 0V to 6V, I <sub>D</sub> = 10A, R <sub>G,on</sub> = 20Ω, R <sub>G,off</sub> = 5Ω, Z <sub>FB</sub> = 120Ω at 100MHz (see Figure 17)	-	40	-	ns
t <sub>R</sub>	Rise time		-	5.6	-	
t <sub>D(off)</sub>	Turn-off delay		-	68	-	
t <sub>F</sub>	Fall time		-	6	-	

1. Dynamic R<sub>DS(on)</sub>, 100% tested; see Figure 21 and Figure 22 for conditions.
2. Equivalent capacitance to give same stored energy from 0V to 400V.
3. Equivalent capacitance to give same charging time from 0V to 400V.

## 2.5 Electrical Specifications – Reverse Device

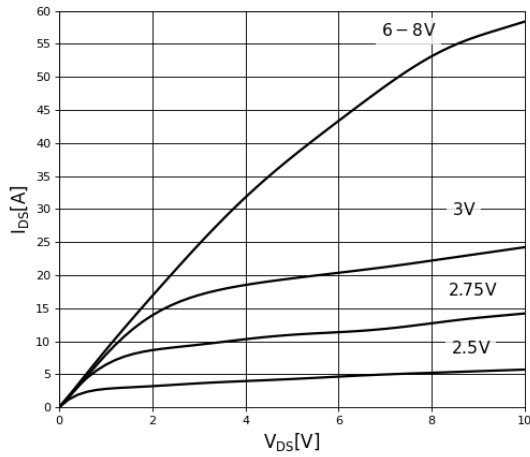
$T_J = 25^\circ\text{C}$  unless otherwise stated.

Symbol	Parameter	Test Conditions	Minimum	Typical	Maximum	Unit
$I_S$	Reverse current	$V_{GS} = 0V, T_C = 100^\circ\text{C},$ $\leq 25\%$ duty cycle	-	-	9	A
$V_{SD}$	Reverse voltage <sup>[1]</sup>	$V_{GS} = 0V, I_S = 10A$	-	2.8	-	V
		$V_{GS} = 0V, I_S = 5A$	-	1.7	-	
$t_{RR}$	Reverse recovery time	$I_S = 10A, V_{DD} = 400V,$ $di/dt = 1000A/\mu\text{s}$	-	32	-	ns
$Q_{RR}$	Reverse recovery charge <sup>[2]</sup>		-	0	-	nC

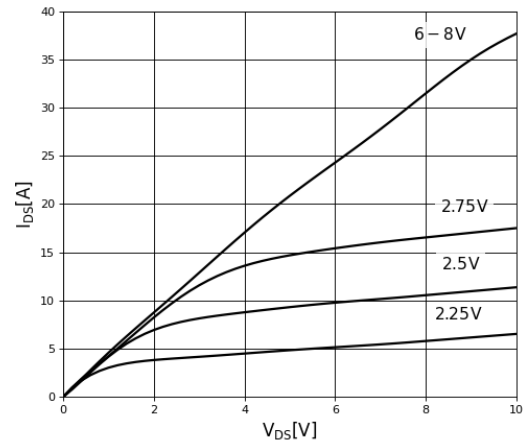
1. Includes dynamic  $R_{DS(on)}$  effect.
2. Excludes  $Q_{oss}$ .

### 3. Typical Performance Graphs

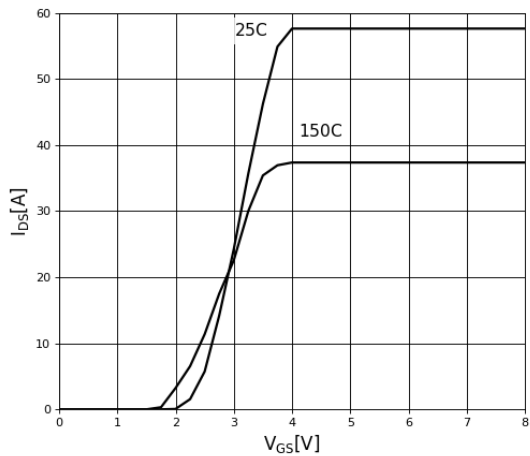
$T_c = 25^\circ\text{C}$  unless otherwise stated.



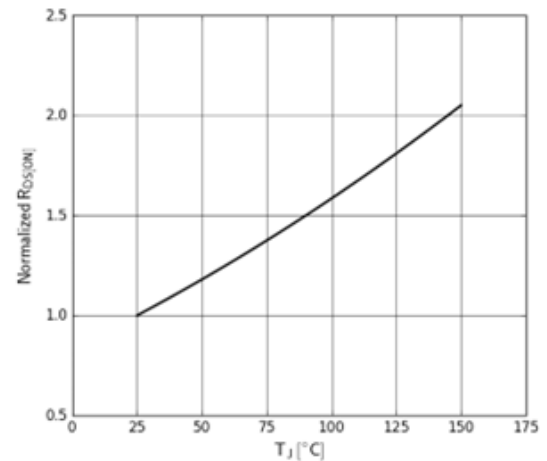
**Figure 4. Typical Output Characteristics,  $T_J = 25^\circ\text{C}$**   
Parameter:  $V_{GS}$



**Figure 5. Typical Output Characteristics,  $T_J = 150^\circ\text{C}$**   
Parameter:  $V_{GS}$

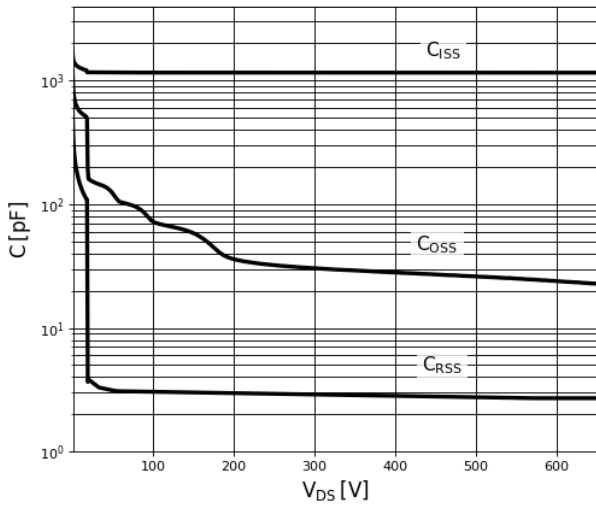


**Figure 6. Typical Transfer Characteristics**  
 $V_{DS} = 10\text{V}$ , parameter:  $T_J$

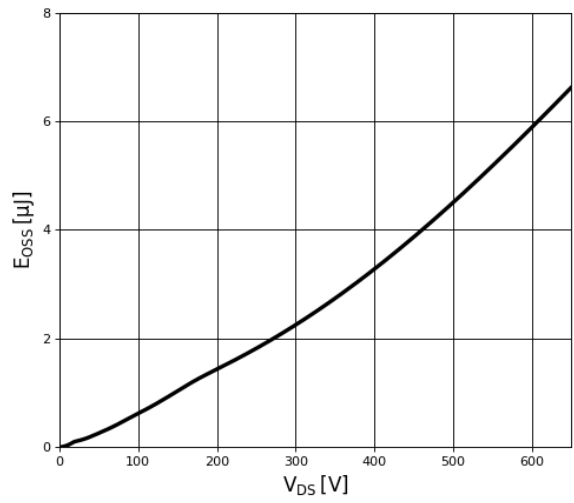


**Figure 7. Normalized On-resistance**  
 $I_D = 10\text{A}$ ,  $V_{GS} = 6\text{V}$

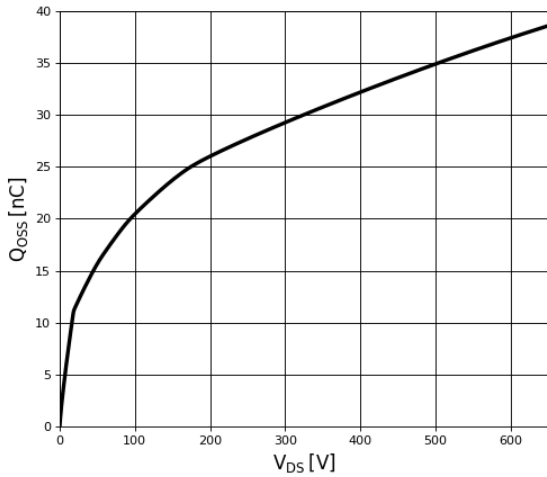




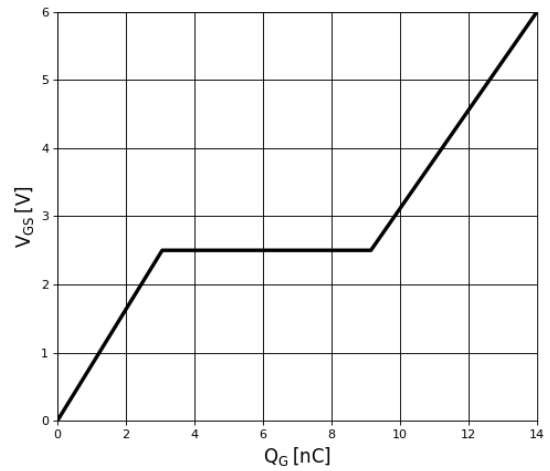
**Figure 8. Typical Capacitance**  
 $V_{GS} = 0V, f = 1MHz$



**Figure 9. Typical Coss Stored Energy**



**Figure 10. Typical Qoss**



**Figure 11. Typical Gate Charge**  
 $I_{DS} = 10A, V_{DS} = 400V$

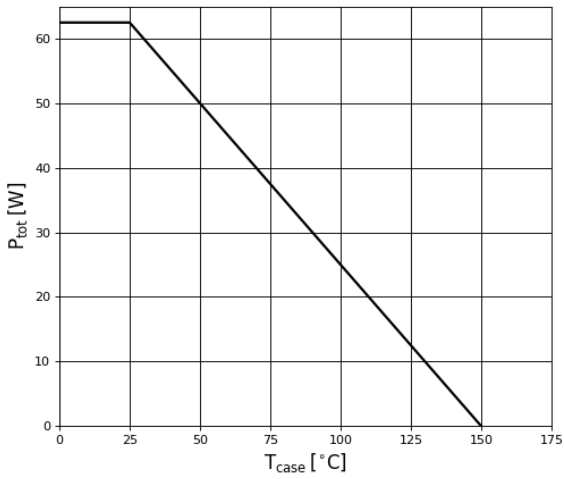


Figure 12. Power Dissipation

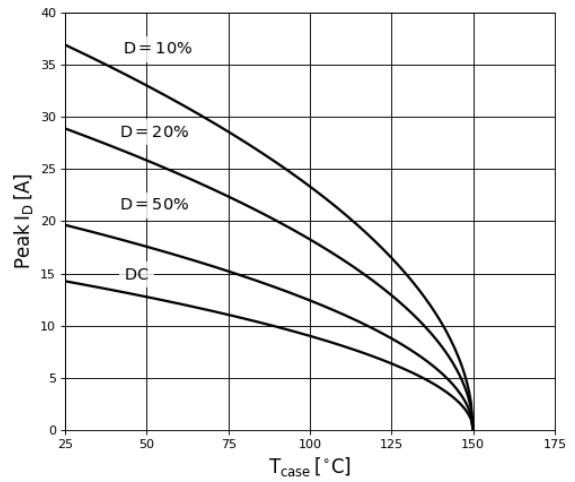


Figure 13. Current Derating  
Pulse width ≤ 10μs, V<sub>GS</sub> ≥ 6V

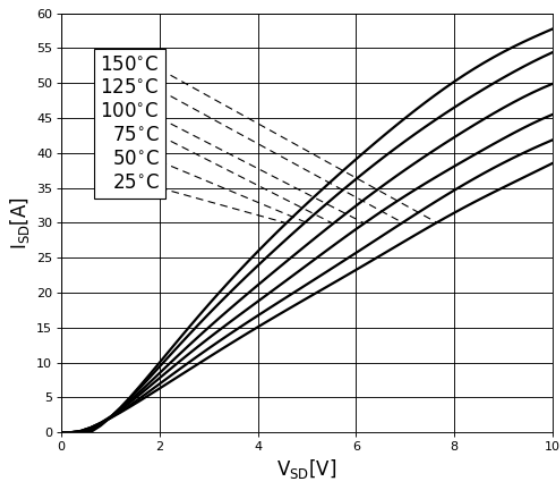


Figure 14. Forward Characteristics of Rev. Diode  
 $I_S = f(V_{SD})$ , parameter: T<sub>J</sub>

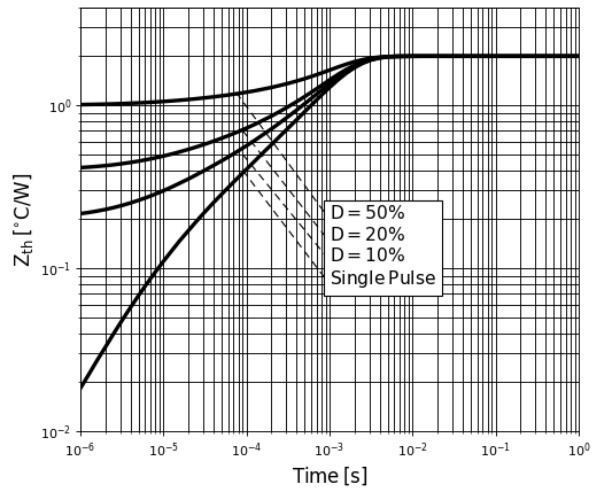


Figure 15. Transient Thermal Resistance

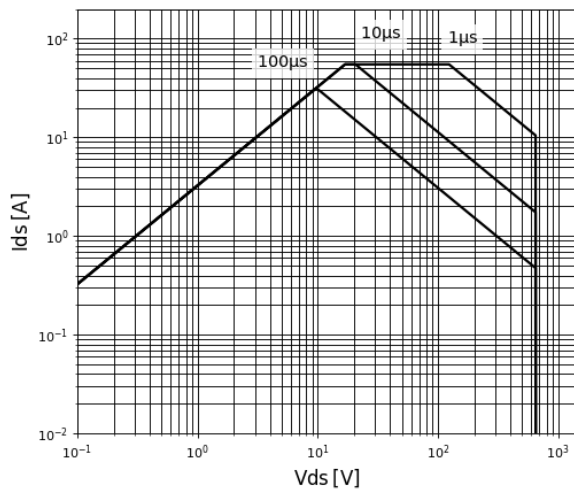


Figure 16. Safe Operating Area  $T_C = 25^\circ\text{C}$

## 4. Test Circuits and Waveforms

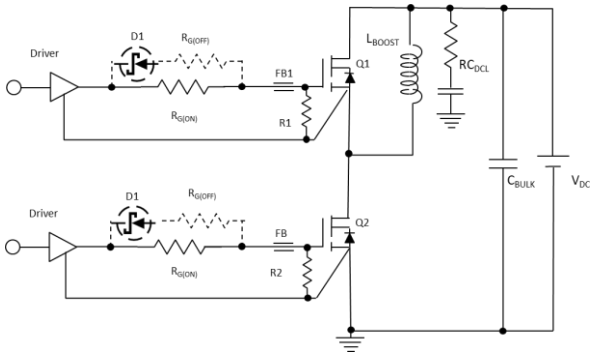


Figure 17. Switching Time Test Circuit

(For methods to ensure clean switching, see “Circuit Implementation”)

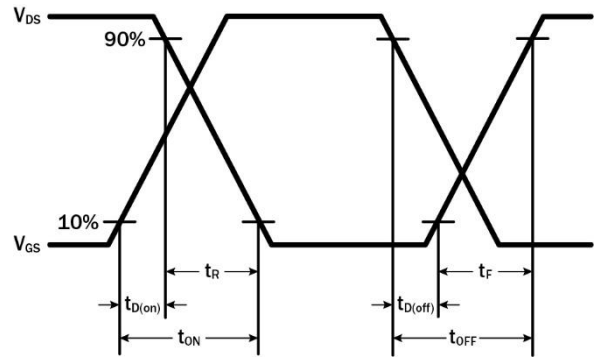


Figure 18. Switching Time Waveform

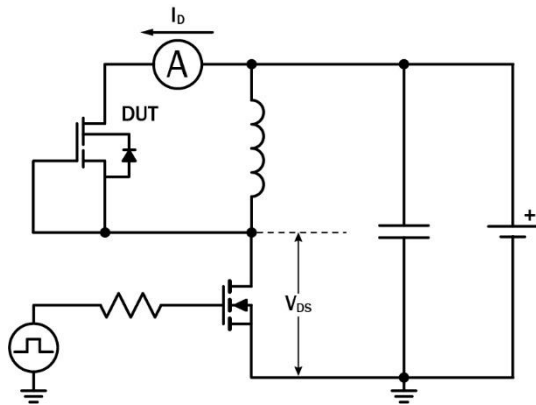


Figure 19. Diode Characteristics Test Circuit

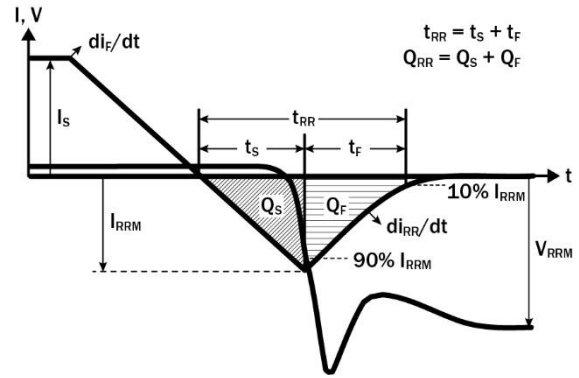


Figure 20. Diode Recovery Waveform

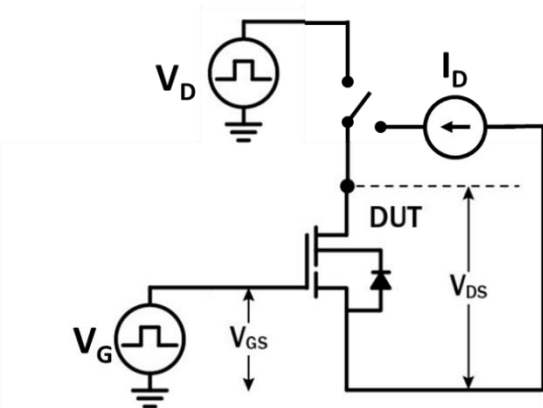


Figure 21. Dynamic  $R_{DS(on)eff}$  Test Circuit

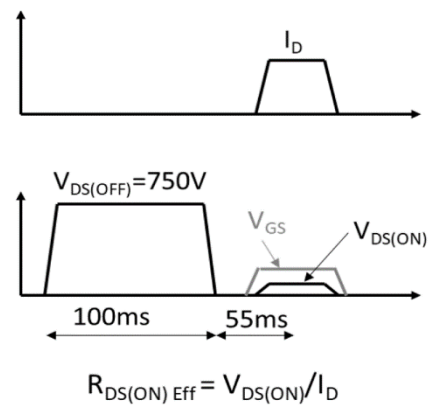
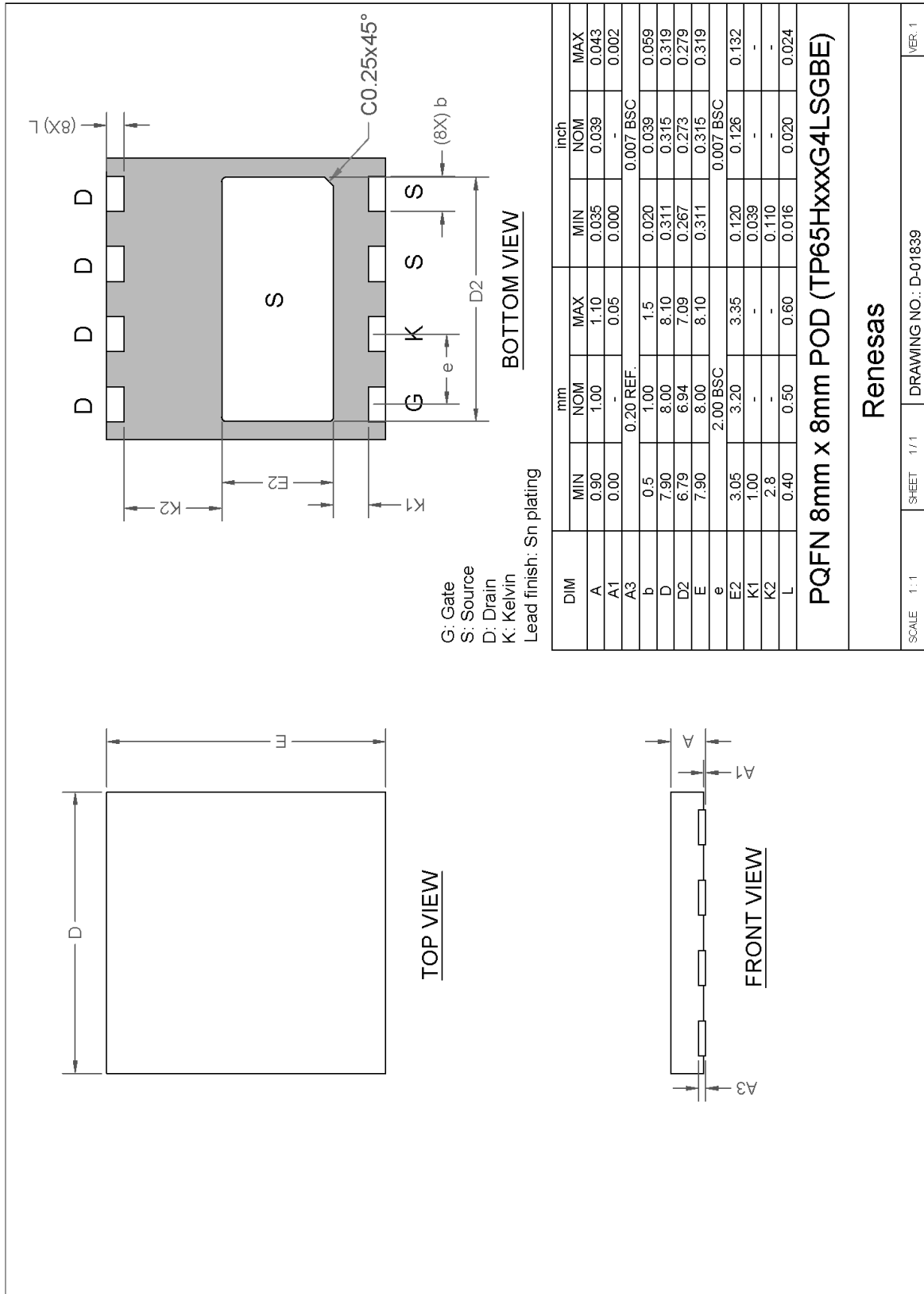


Figure 22. Dynamic  $R_{DS(on)eff}$  Waveform

## 5. Package Outline Drawings



## 6. Design Considerations

The fast switching of GaN devices reduces current-voltage crossover losses and enables high-frequency operation while simultaneously achieving high efficiency. However, taking full advantage of the fast switching characteristics of GaN switches requires adherence to specific PCB layout guidelines and probing techniques.

Before evaluating Renesas GaN devices, see application note [Printed Circuit Board Layout and Probing for GaN Power Switches](#). The following table provides some practical rules that should be followed during the evaluation.

When Evaluating Renesas GaN Devices:	
DO	DO NOT
Minimize circuit inductance by keeping traces short, both in the drive and power loop.	Twist the pins of TO-220 or TO-247 to accommodate GDS board layout.
Minimize lead length of TO-220 and TO-247 package when mounting to the PCB.	Use long traces in drive circuit, long lead length of the devices.
Use shortest sense loop for probing; attach the probe and its ground connection directly to the test points.	Use differential mode probe or probe ground clip with long wire.

## 7. Related Information

The complete technical library of GaN design tools can be found at [Renesas](#):

- Evaluation kits
- Application notes
- Design guides
- Simulation models
- Technical papers and presentations

Specific resources include:

- [Printed Circuit Board Layout and Probing for GaN Power Switches](#)
- [Recommendations for Vapor Phase Reflow](#)
- [Recommended External Circuitry for GaN FETs](#)
- [PQFN Tape and Reel Information](#)

## 8. Ordering Information

Part Number	Package Description	Package Configuration
TP65H150G4LSGBE-TR <sup>[1]</sup>	8 × 8 PQFN	Source

1. "-TR" suffix refers to tape and reel.

## 9. Revision History

Revision	Date	Description
1.00	Apr 3, 2025	Initial release.

## IMPORTANT NOTICE AND DISCLAIMER

RENESAS ELECTRONICS CORPORATION AND ITS SUBSIDIARIES (“RENESAS”) PROVIDES TECHNICAL SPECIFICATIONS AND RELIABILITY DATA (INCLUDING DATASHEETS), DESIGN RESOURCES (INCLUDING REFERENCE DESIGNS), APPLICATION OR OTHER DESIGN ADVICE, WEB TOOLS, SAFETY INFORMATION, AND OTHER RESOURCES “AS IS” AND WITH ALL FAULTS, AND DISCLAIMS ALL WARRANTIES, EXPRESS OR IMPLIED, INCLUDING, WITHOUT LIMITATION, ANY IMPLIED WARRANTIES OF MERCHANTABILITY, FITNESS FOR A PARTICULAR PURPOSE, OR NON-INFRINGEMENT OF THIRD-PARTY INTELLECTUAL PROPERTY RIGHTS.

These resources are intended for developers who are designing with Renesas products. You are solely responsible for (1) selecting the appropriate products for your application, (2) designing, validating, and testing your application, and (3) ensuring your application meets applicable standards, and any other safety, security, or other requirements. These resources are subject to change without notice. Renesas grants you permission to use these resources only to develop an application that uses Renesas products. Other reproduction or use of these resources is strictly prohibited. No license is granted to any other Renesas intellectual property or to any third-party intellectual property. Renesas disclaims responsibility for, and you will fully indemnify Renesas and its representatives against, any claims, damages, costs, losses, or liabilities arising from your use of these resources. Renesas' products are provided only subject to Renesas' Terms and Conditions of Sale or other applicable terms agreed to in writing. No use of any Renesas resources expands or otherwise alters any applicable warranties or warranty disclaimers for these products.

(Disclaimer Rev.1.01)

### Corporate Headquarters

TOYOSU FORESIA, 3-2-24 Toyosu,  
Koto-ku, Tokyo 135-0061, Japan  
[www.renesas.com](http://www.renesas.com)

### Trademarks

Renesas and the Renesas logo are trademarks of Renesas Electronics Corporation. All trademarks and registered trademarks are the property of their respective owners.

### Contact Information

For further information on a product, technology, the most up-to-date version of a document, or your nearest sales office, please visit [www.renesas.com/contact-us/](http://www.renesas.com/contact-us/).