

TP65H030G4PQS

650V SuperGaN® GaN FET in TOLL (source tab)

Description

The TP65H030G4PQS 650V, 30mΩ Gallium Nitride (GaN) FET is a normally-off device using Renesas' Gen IV plus platform. It combines a state-of-the-art high voltage GaN HEMT with a low voltage silicon MOSFET to offer superior performance, standard drive, ease of adoption and reliability.

The Gen IV plus SuperGaN® platform uses advanced epi and patented design technologies to simplify manufacturability while improving efficiency over silicon via lower gate charge, output capacitance, crossover loss, and reverse recovery charge.

Benefits

- Superior normally off architecture with D-mode GaN HEMT
- Compatible with standard silicon drivers
- Enhanced noise immunity with a 4V threshold voltage with no negative gate drive required
- Enables high-efficiency, high power density, and reliable power conversion
- Facilitates cost-effective GaN adoption, reducing system size, weight, and costs

Product and Schematic Diagrams



TP65H030G4PQS TOLL

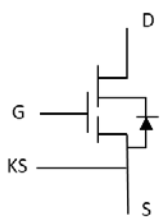

Cascode Schematic Symbol

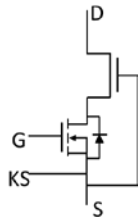

Cascode Device Structure

Features

- Ultra-fast switching Gen IV plus GaN
- JEDEC-qualified GaN technology
- Dynamic  $R_{DS(on)eff}$  production tested
- Reduced crossover loss
- Negligible  $Q_{rr}$
- RoHS compliant and Halogen-free packaging

Applications

- AI datacenter and telecom power supplies
- E-mobility charging
- PV inverter
- UPS
- BESS



Specifications

$V_{DS}$ (V)	650
$V_{DSS(TR)}$ (V) maximum	800
$R_{DS(on)}$ (mΩ) maximum [1]	37
$Q_{OSS}$ (nC) typical	135
$Q_G$ (nC) typical	24.5

1. Dynamic  $R_{DS(on)}$  (see Figure 17 and Figure 18)

## Contents

<b>1. Pin Information</b>	<b>3</b>
1.1 Pin Assignments	3
1.2 Pin Descriptions	3
<b>2. Specifications</b>	<b>4</b>
2.1 Absolute Maximum Ratings	4
2.2 Thermal Specifications	4
2.3 Electrical Specifications – Forward Device	5
2.4 Electrical Specifications – Reverse Device	6
<b>3. Typical Performance Graphs</b>	<b>7</b>
<b>4. Test Circuits and Waveforms</b>	<b>9</b>
<b>5. Package Outline Drawings</b>	<b>10</b>
<b>6. Related Information</b>	<b>11</b>
<b>7. Ordering Information</b>	<b>11</b>
<b>8. Revision History</b>	<b>11</b>

## Figures

Figure 1. Pin Assignments – Bottom View	3
Figure 2. Typical Output Characteristics, $T_J = 25^\circ\text{C}$ Parameter: $V_{GS}$	7
Figure 3. Typical Output Characteristics, $T_J = 150^\circ\text{C}$ Parameter: $V_{GS}$	7
Figure 4. Typical Transfer Characteristics $V_{DS} = 10\text{V}$ , Parameter: $T_J$	7
Figure 5. Normalized On-resistance $I_D = 30\text{A}$ , $V_{GS} = 12\text{V}$	7
Figure 6. Typical Capacitance $V_{GS} = 0\text{V}$ , $f = 1\text{MHz}$	7
Figure 7. Typical $C_{OSS}$ Stored Energy	7
Figure 8. Typical $Q_{OSS}$	8
Figure 9. Typical Gate Charge	8
Figure 10. Power Dissipation	8
Figure 11. Current Derating	8
Figure 12. Forward Characteristics of Rev. Diode	8
Figure 13. Transient Thermal Resistance	8
Figure 14. Safe Operating Area $T_C = 25^\circ\text{C}$	9
Figure 15. Switching Time Test Circuit	9
Figure 16. Switching Time Waveform	9
Figure 17. Dynamic $R_{DS(on)eff}$ Test Circuit	9
Figure 18. Dynamic $R_{DS(on)eff}$ Waveform	9
Figure 19. 10 x 12 mm TOLL Package Outline Drawing	10

# 1. Pin Information

## 1.1 Pin Assignments

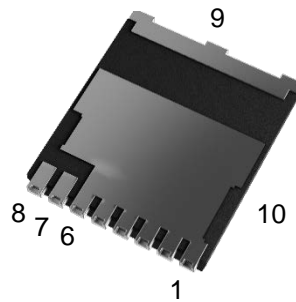

Figure 1. Pin Assignments – Bottom View

## 1.2 Pin Descriptions

Pin Number	Pin Name	Description
1, 2, 3, 4, 5, 6	S	Source.
7	KS	Kelvin Source.
8	G	Gate.
9	D	Drain.
10	S	Source.

## 2. Specifications

### 2.1 Absolute Maximum Ratings

$T_c = 25^\circ\text{C}$  unless otherwise stated.

**Caution:** Do not operate at or near the maximum ratings listed for extended periods of time. Exposure to such conditions can adversely impact product reliability and result in failures not covered by warranty.

Symbol	Parameter	Minimum	Maximum	Unit
$V_{DSS}$	Drain to source voltage ( $T_J = -55^\circ\text{C}$ to $150^\circ\text{C}$ )	-	650	V
$V_{DSS(TR)}$	Transient drain to source voltage <sup>[1]</sup>	-	800	
$V_{DSS(TR), \text{pulsed}}$	Drain to source voltage, pulsed <sup>[2]</sup>	-	750	
$V_{GSS}$	Gate to source voltage	-20	+20	
$P_D$	Maximum power dissipation at $T_c = 25^\circ\text{C}$	-	192	W
$I_D$	Continuous drain current at $T_c = 25^\circ\text{C}$	-	55.7	A
	Continuous drain current at $T_c = 100^\circ\text{C}$	-	35	A
$I_{DM}$	Pulsed drain current (pulse width: 10 $\mu\text{s}$ )	-	230	A
$T_J$	Operating temperature junction	-55	+150	$^\circ\text{C}$
$T_S$	Storage temperature	-55	+150	$^\circ\text{C}$
$T_{SOLD}$	Reflow soldering temperature <sup>[3]</sup>	-	260	$^\circ\text{C}$

- $V_{GS} = 0\text{V}$ ,  $\leq 10\mu\text{s}$ ,  $\leq 1\%$  Duty Cycle, cumulative 60s (60 million pulses).
- $V_{GS} = 0\text{V}$ ,  $\leq 1\mu\text{s}$ ,  $\leq 1\%$  Duty Cycle, cumulative 10h (36 billion pulses).
- Reflow MSL3.

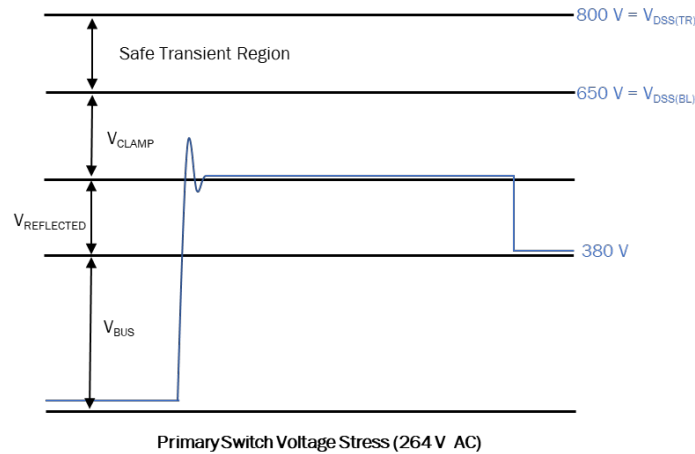

### 2.2 Thermal Specifications

Symbol	Condition	Typical Value	Unit
$R_{\theta JC}$	Junction-to-case	0.65	$^\circ\text{C}/\text{W}$
$R_{\theta JA}$	Junction-to-ambient	40	

## 2.3 Electrical Specifications – Forward Device

T<sub>J</sub> = 25°C unless otherwise stated.

Symbol	Parameter	Test Conditions	Minimum	Typical	Maximum	Unit
V <sub>DSS(BL)</sub>	Maximum drain-source voltage	V <sub>GS</sub> = 0V	650	-	-	V
V <sub>GS(th)</sub>	Gate threshold voltage	V <sub>DS</sub> = V <sub>GS</sub> , I <sub>D</sub> = 1mA	3.3	4	4.8	V
ΔV <sub>GS(th)</sub> /T <sub>J</sub>	Gate threshold voltage temperature coefficient		-	-6.5	-	mV/°C
R <sub>DS(on)eff</sub>	Drain-source on-resistance <sup>[1]</sup>	V <sub>GS</sub> = 12V, I <sub>D</sub> = 30A, T <sub>J</sub> = 25°C	-	30	37	mΩ
		V <sub>GS</sub> = 12V, I <sub>D</sub> = 30A, T <sub>J</sub> = 150°C	-	62	-	
I <sub>DSS</sub>	Drain-to-source leakage current	V <sub>DS</sub> = 650V, V <sub>GS</sub> = 0V, T <sub>J</sub> = 25°C	-	3	30	μA
		V <sub>DS</sub> = 650V, V <sub>GS</sub> = 0V, T <sub>J</sub> = 150°C	-	20	-	
I <sub>GSS</sub>	Gate-to-source forward leakage current	V <sub>GS</sub> = 20V	-	-	400	nA
	Gate-to-source reverse leakage current	V <sub>GS</sub> = -20V	-	-	-400	
C <sub>ISS</sub>	Input capacitance	V <sub>GS</sub> = 0V, V <sub>DS</sub> = 400V, f = 1MHz	-	1500	-	pF
C <sub>OSS</sub>	Output capacitance		-	127	-	
C <sub>RSS</sub>	Reverse transfer capacitance		-	4.6	-	
C <sub>O(er)</sub>	Output capacitance, energy related <sup>[2]</sup>	V <sub>GS</sub> = 0V, V <sub>DS</sub> = 0V to 400V	-	183	-	pF
C <sub>O(tr)</sub>	Output capacitance, time related <sup>[3]</sup>		-	339	-	
Q <sub>G</sub>	Total gate charge	V <sub>DS</sub> = 400V, V <sub>GS</sub> = 0V to 12V, I <sub>D</sub> = 30A	-	24.5	-	nC
Q <sub>GS</sub>	Gate-source charge		-	8.4	-	
Q <sub>GD</sub>	Gate-drain charge		-	6.6	-	
Q <sub>OSS</sub>	Output charge	V <sub>GS</sub> = 0V, V <sub>DS</sub> = 0V to 400V	-	135	-	nC
t <sub>D(on)</sub>	Turn-on delay	V <sub>DS</sub> = 400V, V <sub>GS</sub> = 0V to 12V, R <sub>G(on)</sub> = 10Ω, R <sub>G(off)</sub> = 30Ω, I <sub>D</sub> = 30A, Z <sub>FB</sub> = 180Ω at 100MHz (see Figure 15)	-	26.4	-	ns
t <sub>R</sub>	Rise time		-	6.4	-	
t <sub>D(off)</sub>	Turn-off delay		-	63.6	-	
t <sub>F</sub>	Fall time		-	8	-	

1. Dynamic R<sub>DS(on)</sub>, 100% tested; see Figure 17 and Figure 18 for conditions.
2. Equivalent capacitance to give same stored energy from 0V to 400V.
3. Equivalent capacitance to give same charging time from 0V to 400V.

## 2.4 Electrical Specifications – Reverse Device

$T_J = 25^\circ\text{C}$  unless otherwise stated.

Symbol	Parameter	Test Conditions	Minimum	Typical	Maximum	Unit
$I_S$	Reverse current	$V_{GS} = 0V$ , $T_C = 100^\circ\text{C}$ , $\leq 25\%$ duty cycle	-	-	32	A
$V_{SD}$	Reverse voltage <sup>[1]</sup>	$V_{GS} = 0V$ , $I_S = 32A$	-	1.8	-	V
		$V_{GS} = 0V$ , $I_S = 16A$	-	1.3	-	

1. Includes dynamic  $R_{DS(on)}$  effect.

Note: Reverse recovery charge is negligible, enabled by the LV Si FET technology

### 3. Typical Performance Graphs

$T_c = 25^\circ\text{C}$  unless otherwise stated.

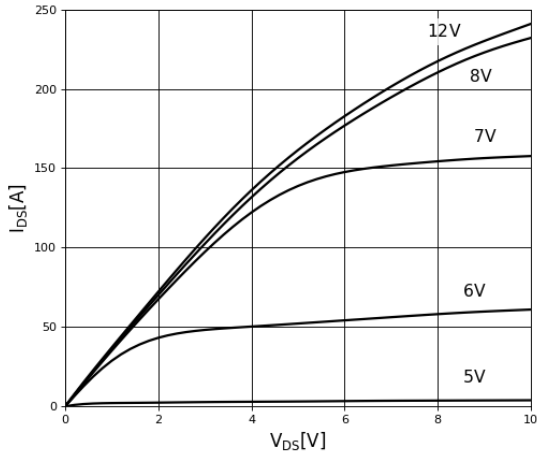

**Figure 2. Typical Output Characteristics,  $T_J = 25^\circ\text{C}$**   
Parameter:  $V_{GS}$

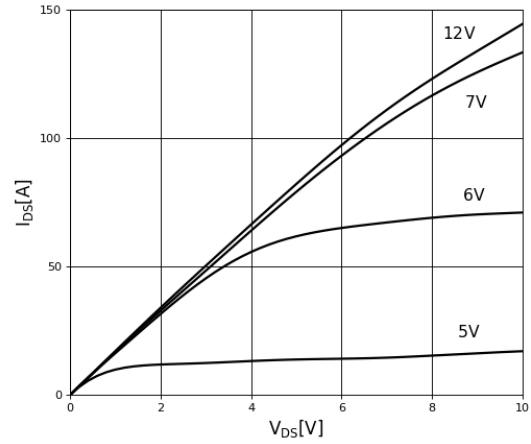

**Figure 3. Typical Output Characteristics,  $T_J = 150^\circ\text{C}$**   
Parameter:  $V_{GS}$

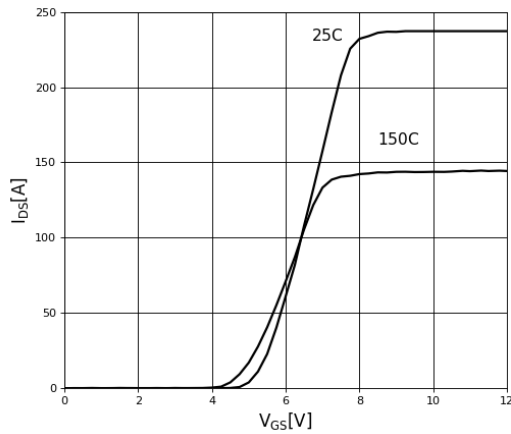

**Figure 4. Typical Transfer Characteristics**  
 $V_{DS} = 10\text{V}$ , Parameter:  $T_J$

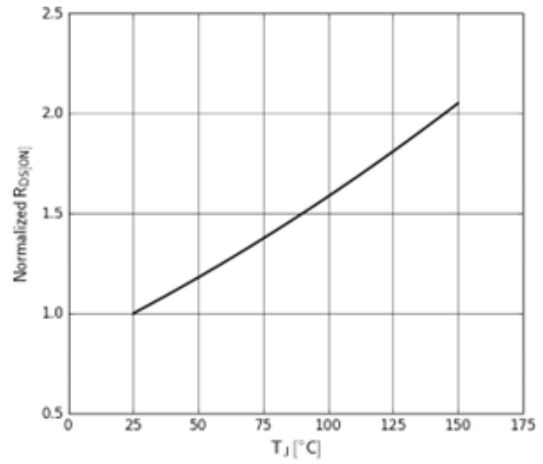

**Figure 5. Normalized On-resistance**  
 $I_D = 30\text{A}$ ,  $V_{GS} = 12\text{V}$

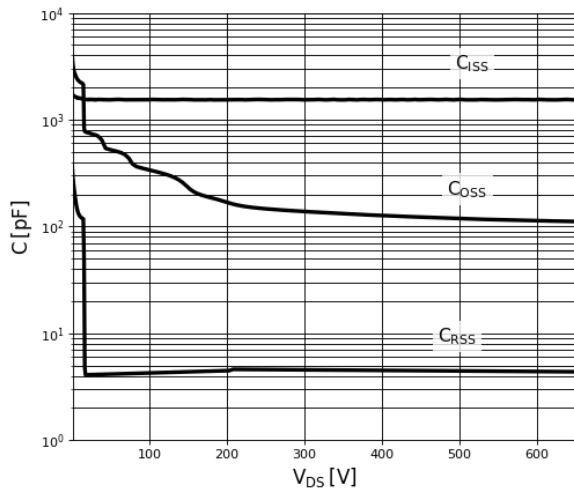

**Figure 6. Typical Capacitance**  
 $V_{GS} = 0\text{V}$ ,  $f = 1\text{MHz}$

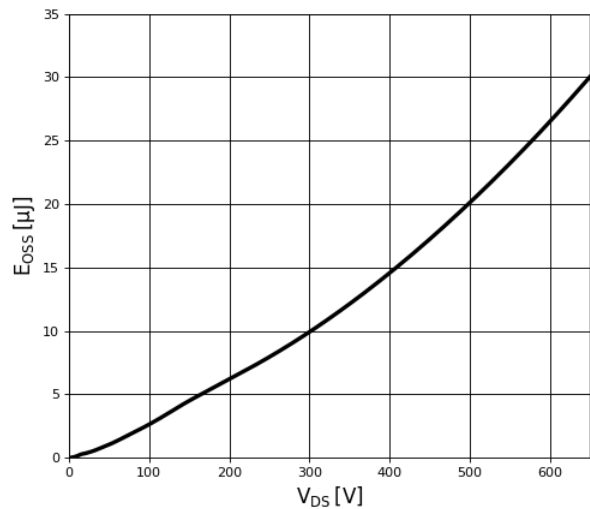

**Figure 7. Typical  $C_{OSS}$  Stored Energy**

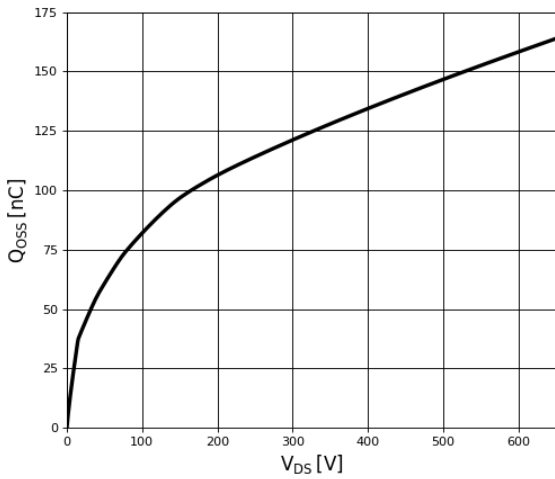

Figure 8. Typical Qoss

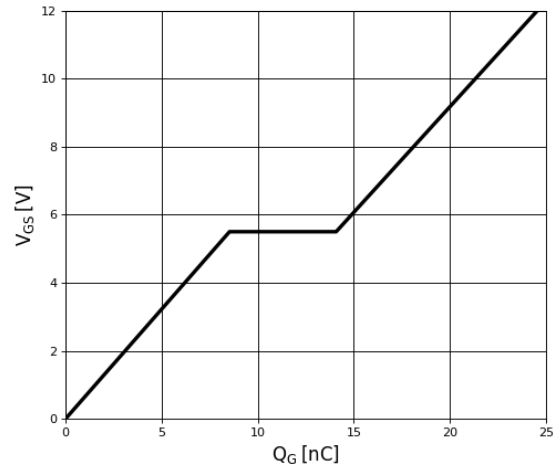

Figure 9. Typical Gate Charge

$I_{DS} = 30A, V_{DS} = 400V$

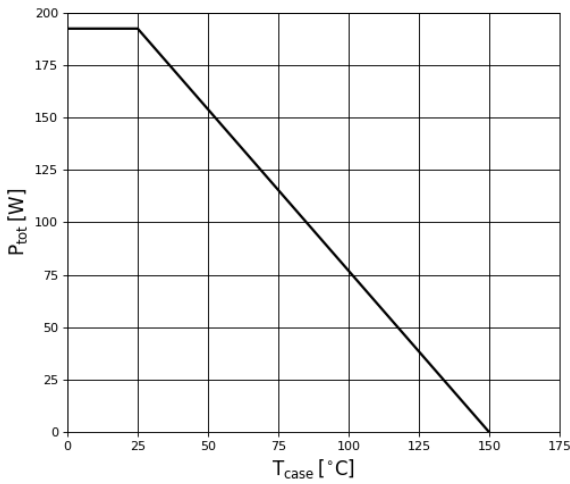

Figure 10. Power Dissipation

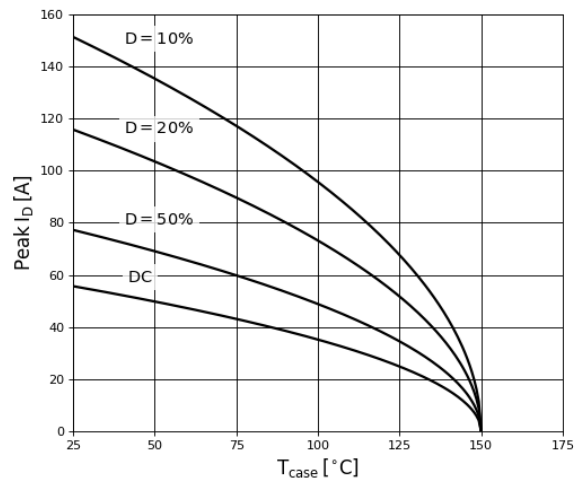

Figure 11. Current Derating

Pulse width  $\leq 10\mu s, V_{GS} \geq 12V$

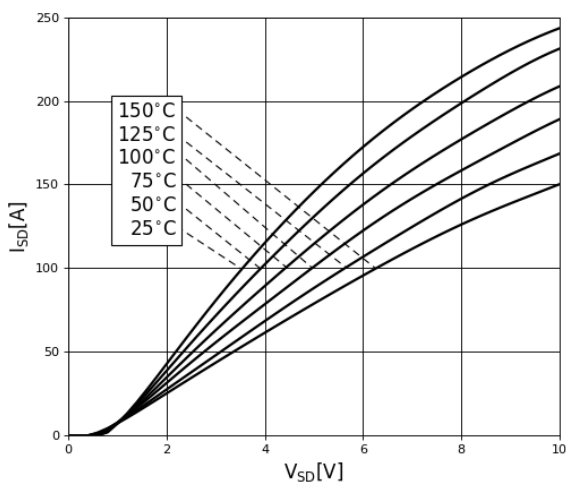

Figure 12. Forward Characteristics of Rev. Diode

$I_S = f(V_{SD}),$  Parameter:  $T_J$

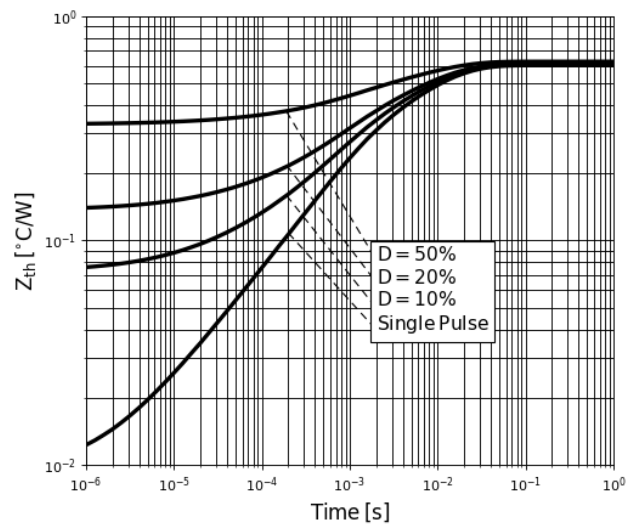

Figure 13. Transient Thermal Resistance

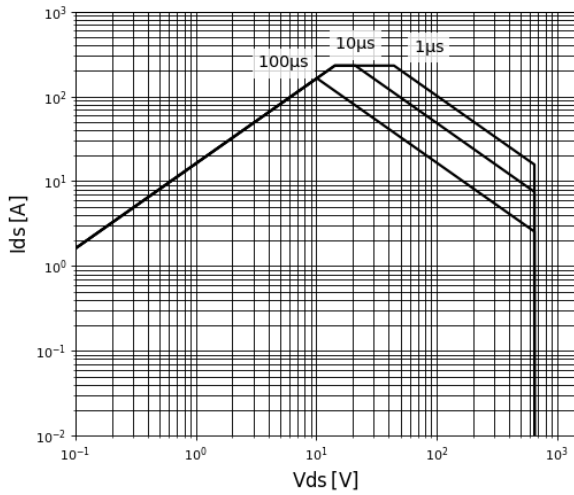

Figure 14. Safe Operating Area  $T_c = 25^\circ\text{C}$

#### 4. Test Circuits and Waveforms

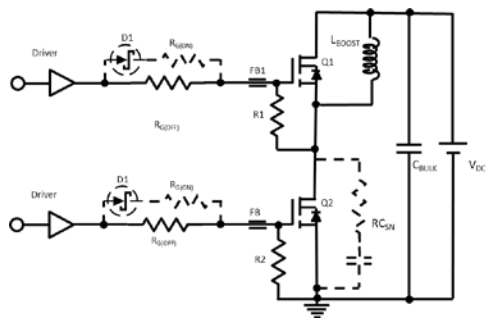

Figure 15. Switching Time Test Circuit

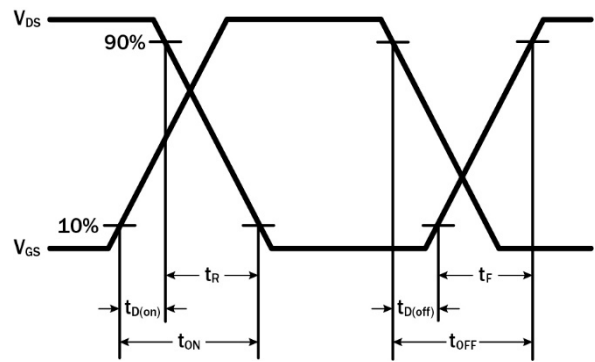

Figure 16. Switching Time Waveform

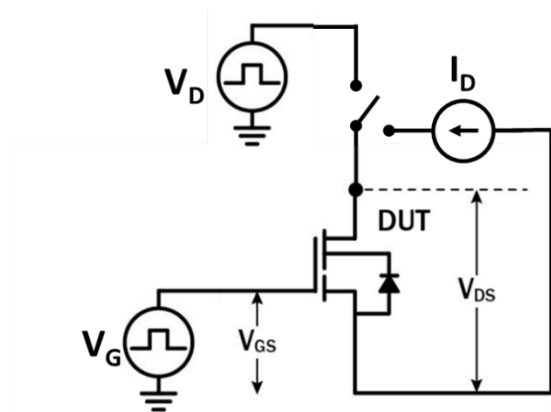

Figure 17. Dynamic  $R_{DS(on)eff}$  Test Circuit

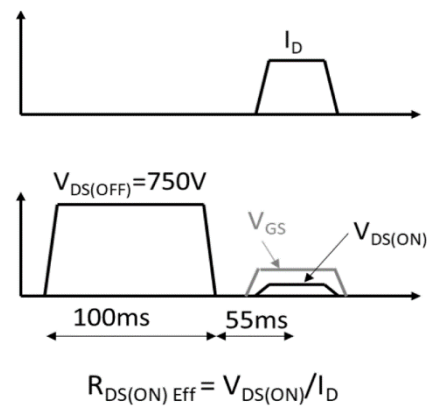

Figure 18. Dynamic  $R_{DS(on)eff}$  Waveform

## 5. Package Outline Drawings

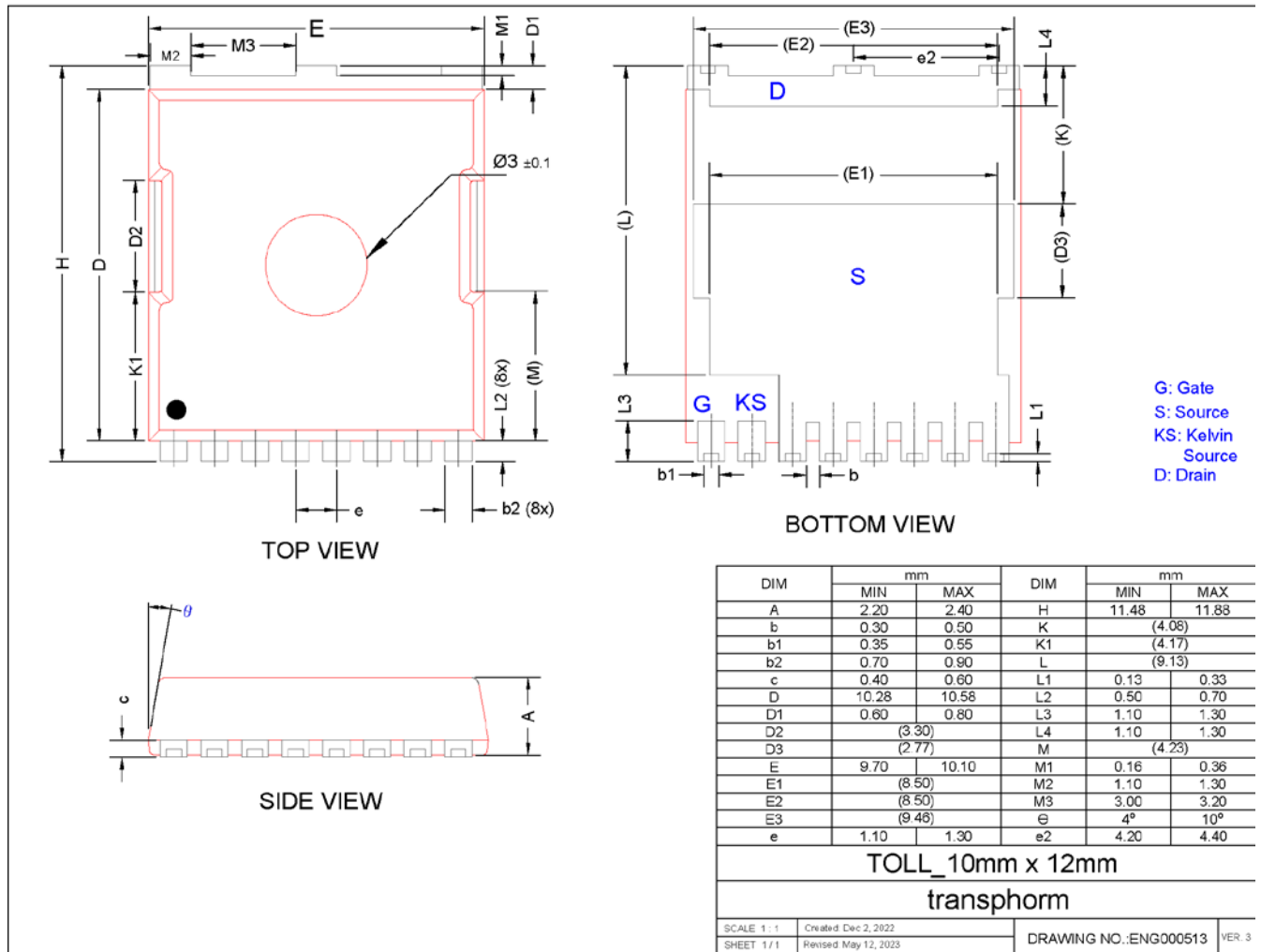

Figure 19. 10 x 12 mm TOLL Package Outline Drawing

## 6. Related Information

All technical documents for Renesas GaN Power devices are accessible from the [GaN Power Solutions](#) page.

## 7. Ordering Information

Part Number	Package Description	Package Configuration
TP65H030G4PQS	TOLL	Source tab

## 8. Revision History

Revision	Date	Description
2.01	June 29, 2026	Updated maximum Rds(on) specification and transient voltage test conditions.
2.00	Nov 25, 2025	Updated the document's formatting; no technical changes were completed.
1.00	May 16, 2025	Initial release.

## IMPORTANT NOTICE AND DISCLAIMER

RENESAS ELECTRONICS CORPORATION AND ITS SUBSIDIARIES (“RENESAS”) PROVIDES TECHNICAL SPECIFICATIONS AND RELIABILITY DATA (INCLUDING DATASHEETS), DESIGN RESOURCES (INCLUDING REFERENCE DESIGNS), APPLICATION OR OTHER DESIGN ADVICE, WEB TOOLS, SAFETY INFORMATION, AND OTHER RESOURCES “AS IS” AND WITH ALL FAULTS, AND DISCLAIMS ALL WARRANTIES, EXPRESS OR IMPLIED, INCLUDING, WITHOUT LIMITATION, ANY IMPLIED WARRANTIES OF MERCHANTABILITY, FITNESS FOR A PARTICULAR PURPOSE, OR NON-INFRINGEMENT OF THIRD-PARTY INTELLECTUAL PROPERTY RIGHTS.

These resources are intended for developers who are designing with Renesas products. You are solely responsible for (1) selecting the appropriate products for your application, (2) designing, validating, and testing your application, and (3) ensuring your application meets applicable standards, and any other safety, security, or other requirements. These resources are subject to change without notice. Renesas grants you permission to use these resources only to develop an application that uses Renesas products. Other reproduction or use of these resources is strictly prohibited. No license is granted to any other Renesas intellectual property or to any third-party intellectual property. Renesas disclaims responsibility for, and you will fully indemnify Renesas and its representatives against, any claims, damages, costs, losses, or liabilities arising from your use of these resources. Renesas' products are provided only subject to Renesas' Terms and Conditions of Sale or other applicable terms agreed to in writing. No use of any Renesas resources expands or otherwise alters any applicable warranties or warranty disclaimers for these products.

(Disclaimer Rev.1.01)

### Corporate Headquarters

TOYOSU FORESIA, 3-2-24 Toyosu,  
Koto-ku, Tokyo 135-0061, Japan  
[www.renesas.com](http://www.renesas.com)

### Trademarks

Renesas and the Renesas logo are trademarks of Renesas Electronics Corporation. All trademarks and registered trademarks are the property of their respective owners.

### Contact Information

For further information on a product, technology, the most up-to-date version of a document, or your nearest sales office, please visit [www.renesas.com/contact-us/](http://www.renesas.com/contact-us/).