

SMOD701

Hydrogen Gas Smart Sensing Module

The [SMOD701](#) is a complete smart sensing solution for measuring hydrogen (H₂) gas in the parts per million range. The module, consisting of the SMOD smart sensing platform combined with IDT's SGAS701 H₂ sensor, provides an indication of hydrogen gas measured both as resistance and as a linear response proportional to ppm of H₂. The SMOD701 communicates with an external controller or a data logger via a USB interface, and can be supplied with an UART interface by special order.

The SGAS701 sensor can be supplied separately from the SMOD701 Smart Sensing Module. For more information, see the *SGAS701 Datasheet*.

Features

- High-sensitivity, fast detection of hydrogen gas
- Sensor operating parameters can be tailored to specific hydrogen measurement applications
- Targeted toward OEM system integration and peripheral device applications

Applications

- Leak detection
- Fuel cell and battery gas measurements

SMOD701 Smart Module



Typical Module Response

Figure 1 and Figure 2 show the typical response and selectivity of the SMOD701 module when operated in clean, dry air.

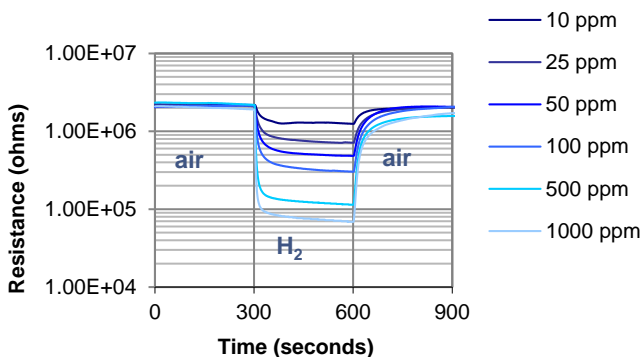

Figure 1. Typical H₂ Response:
Air applied for 300 seconds, then H₂ in air for 300 seconds, followed by air

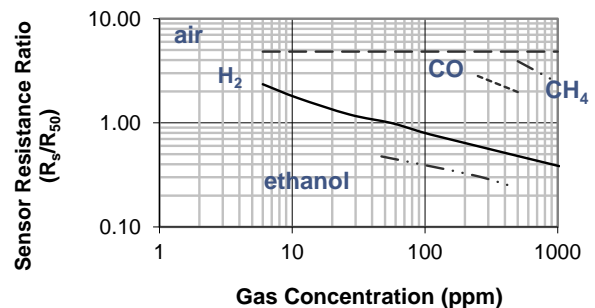

Figure 2. Selectivity Characteristics:
R_s = Resistance in displayed gas
R₅₀ = Resistance in 50ppm H₂

Contents

1. Specifications	3
1.1 Absolute Maximum Ratings.....	3
1.2 Recommended Operating Conditions	3
1.3 DC Electrical Characteristics	3
1.4 Interface Characteristics.....	4
2. Connector Assignments	4
3. Principles of Operation	5
3.1 Power Requirements	6
3.2 External Communication	6
3.3 Sensor Operating Conditions	6
3.4 Communication Protocol	6
3.5 Command Summary.....	8
3.6 Sensor Replacement	9
4. Package Outline Drawing	9
5. Ordering Information	9
6. Revision History	10

1. Specifications

1.1 Absolute Maximum Ratings

Stresses above the ratings listed below can cause permanent damage to the SMOD701. These ratings, which are standard values for IDT commercially rated parts, are stress ratings only. Functional operation of the device at these or any other conditions above those indicated in the operational sections of the specifications is not implied. Exposure to absolute maximum rating conditions for extended periods can affect product reliability. Electrical parameters are guaranteed only over the recommended operating temperature range.

Symbol	Parameter	Conditions	Minimum	Maximum	Unit
V_{IN}	Supply Voltage (referenced to ground)			12	V
	Digital Inputs and Output Voltage Level		-0.5	3.8	V
	Electrostatic Discharge (MIL-STD-883)		2000		V
T_{AMB}	Ambient Operating Temperature		0	50	°C
T_{STOR}	Storage Temperature		-65	150	°C

1.2 Recommended Operating Conditions

Symbol	Parameter	Minimum	Typical	Maximum	Unit
V_{IN}	Supply Voltage (referenced to ground)		9		V
T_{AMB}	Ambient Operating Temperature	0		50	°C
RH	Ambient Relative Humidity – Non-condensing	0		95	%

1.3 DC Electrical Characteristics

Symbol	Parameter	Conditions	Minimum	Typical	Maximum	Unit
V_{IN}	Input Voltage		6.5	9	12	V
$V_{IN,RIPL}$	Input Voltage Ripple	$I_{HTR} = 114\text{mA}$			100	mV _{PP}
I_{IN}	Input Supply Current	$I_{HTR} = 114\text{mA}$		120	140	mA
V_{HTR}	Heater Drive Voltage			5.4	6.0	V
I_{HTR}	Heater Drive Current			112	125	mA
V_{SEN}	Sensor Drive Voltage				3.0	V

1.4 Interface Characteristics

The SMOD701 utilizes a USB communication interface that conforms to the USB 2.0 standard. Uart communication can be established using the settings shown in Table 1.

Table 1. SMOD701 UART Settings

Baudrate	Data	Stop	Parity	LSB
9600	8 bits	1 bit	Even	First

2. Connector Assignments

Refer to Figure 3 for the location of the connectors described in the following tables.

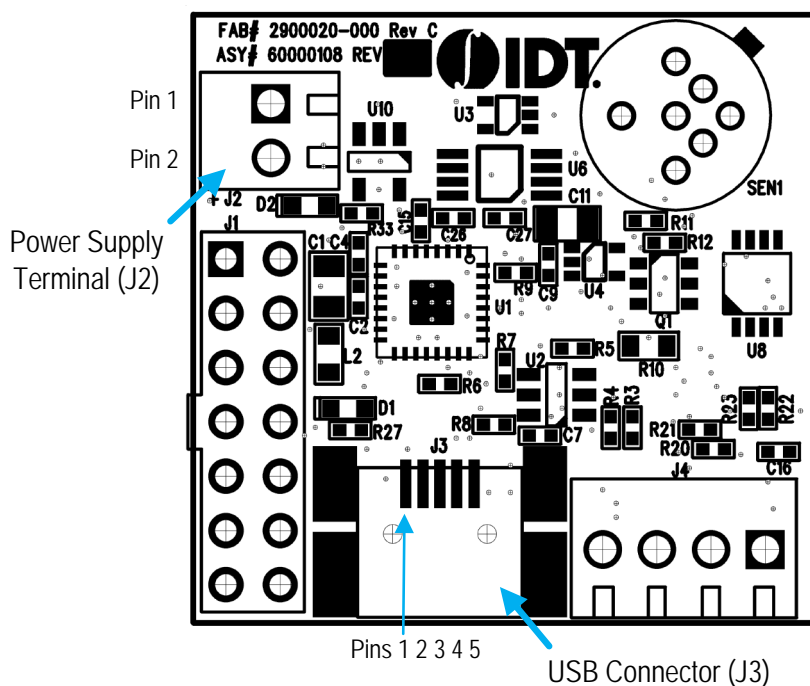

Figure 3. Connector Locations on the SMOD701

Table 2. Pin Assignments: 2-Post Screw Terminal for Input Power (J2)

Pin Number	Description
1	Power ground
2	V _{IN}

Table 3. Pin Assignments: Mini-B Connector for USB Communications (J3)

Pin Number	Description
1	VBUS
2	D+
3	D-
4	No connection
5	USB ground

The SGAS701 hydrogen sensor is housed in a TO-39 package. Figure 4 shows the combined TO-39/46 sensor socket (SEN1) on the module. The SGAS701 sensor utilizes pins 1, 2, 3, and 4 (pins 5, 6 and 7 are unused). Table 4 provides the definitions of the pins.

Figure 4. Top View SEN1 Sensor Socket

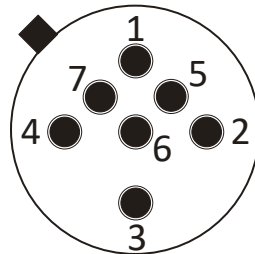

Table 4. Pin Assignments: TO-39 Sensor Socket for SGAS701 (SEN1)

Pin Number	Name	Description
1	Heater +	Positive input for V_H heater voltage supply
2	Sensor +	High-side of resistive sensor element; positive input for sensing voltage V_C
3	Heater –	Negative (ground) input for V_H heater voltage supply
4	Sensor –	Low-side of resistive sensor element; connects to middle of resistor divider circuit to produce sensing voltage output (V_{OUT})

3. Principles of Operation

The SMOD701 module consists of a combination of the SMOD smart sensing platform and a SGAS701 hydrogen sensor. The SMOD smart sensing platform is a general purpose microcontroller-based device with a broad array of capabilities that can be applied in gas sensing applications. As in other SMOD7xx devices, the SMOD701 selects a subset of measurement and control capabilities from a larger set and adds application-specific settings/capability, such as default sensor operation parameters, and calibration and analysis algorithms appropriate for the gas sensor utilized in the module.

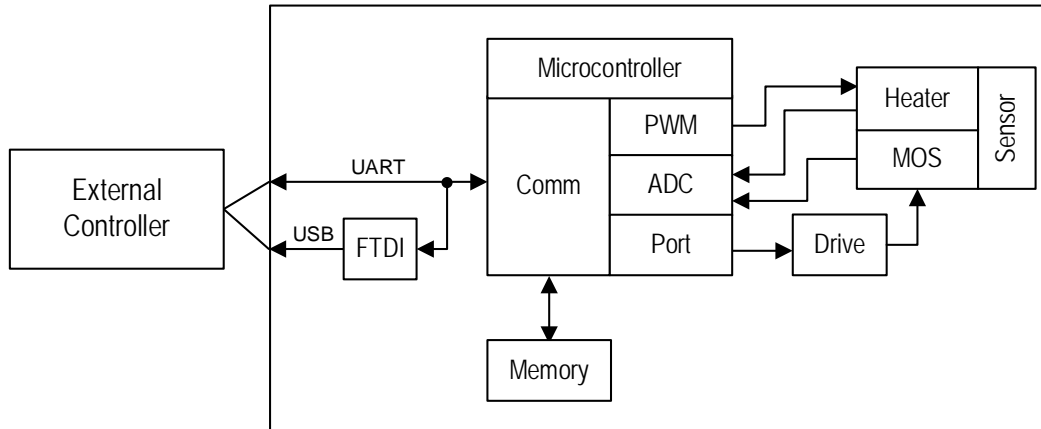

Figure 5. SMOD701 Block Diagram

3.1 Power Requirements

The SMOD701 utilizes an SGAS701 ceramic sensor that requires a nominal heater drive of 5.4V at 112mA. The input power to the module must be sourced from an external power supply connected to J2. This power supply must be capable of providing a minimum of 6.5VDC at 140mA to the module.

External commands (described below) support operation of the sensor heater at voltages other than 5.4V. Power supplied to the module does not require regulation, but the supply should have a ripple of less than 0.1V_{PP} under load.

3.2 External Communication

The SMOD701 communicates with external devices via a USB connection at J3 (Mini-B connector). The SMOD701 conforms to the USB 2.0 specification (full speed). The communication protocol used for sending commands to and receiving responses from the SMOD701 is described in the “Communication Protocol” section.

3.3 Sensor Operating Conditions

The SMOD701 operates the SGAS701 sensor in isothermal mode at a constant heater voltage defaulting to 5.4V. This corresponds to a nominal heater current of 112mA and a heater power of approximately 600mW. The heater voltage is regulated via a feedback measurement so that the voltage set-point is maintained under changing environmental conditions. The heater voltage set-point can be altered via the **HVw** command described in the “Command Summary” section.

Sensor measurements are performed by default once every second; this rate can be changed to any value between 1 and 60 seconds using the **PDw** command.

3.4 Communication Protocol

The external communication protocol is a mixed ASCII-binary protocol with the intent that both SMOD7xx firmware and external communication software be as similar as possible across UART and USB based modules. All communication initiates from the external device, with the exception of the *data ready* signal that is pre-emptively sent from the module to the external device when module-generated data is available for fetching by the external device. All commands to the module are responded to with a sequence consisting of a 1-byte *count* followed by 2 or more bytes as specified by *count*. The first two bytes after *count* are an unsigned 16-bit status word containing values as specified in Table 5. Command responses might contain additional information depending upon the specific command received by the module.

For USB-based modules, the data ready signal consists of the transmission of the three-character ASCII sequence INT. The external device is responsible for monitoring USB transmissions for this sequence and responding appropriately with the **GD** (get data) command.

Commands to the module are delimited by a colon (:) at the start of the request and a semicolon (;) at the end. Commands consist of a two or three letter command identifier, followed by zero or more space-separated numeric parameters. Numbers may contain a decimal point, but individual commands might interpret floating point inputs as integers and vice versa. Exponential formats are not allowed. Most commands are constructed using a two-letter acronym for the command plus an appended *w* (for write) or *r* (for read). For example, the command to write the heater voltage is **:HCw**; while the command to read the heater voltage is **:HCr**;

A LabVIEW®-based¹ application and associated interface drivers are available as an example to aid in implementation of communication between the SMOD701 and external devices.

Table 5. Status Return Values

Status	Meaning
0	SUCCESS
1	ERROR_INIT
2	ERROR_WR_EEPROM
3	ERROR_FTDI_NOT_READY
4	ERROR_WR_BUF_OVL
5	ERROR_INVALID_SIGN
6	ERROR_INVALID_CMD
7	ERROR_PARAM_OUT_OF_RANGE
8	ERROR_PARAM_ORDER
9	ERROR_NO_PERIOD_SET
10	ERROR_NO_ADC_POINTS_SET
11	ERROR_NUMBER_OF_PARAMS
12	ERROR_STEP_MISMATCH
13	RETURN_VALUE
14	ERROR_CONFIG
15	NOT_INDEPENDENT
16	ERROR_WRONG_PASSWORD
17	ERROR_CMD_NOT_ALLOWED
18	INDEPENDENT
19	ERROR_FLASH_CLK
255	RESTART_REQUIRED

¹ LabVIEW® is a trademark of National Instruments Corporation.

3.5 Command Summary

Six commands are available to control the SMOD701:

- :CPw {p1}{p2}; Writes the calibration parameters used in converting resistance to linear sensor response. **p1** and **p2** are supplied by the factory on a sensor-by-sensor basis. Response is **{byteCount}{status}**.
- :HVr; Reads the heater voltage set point in the SMOD701. The response is **{byteCount}{status}{voltage}**, where the voltage is specified in millivolts.
- :HVw {voltage}; Writes the voltage at which the heater is to be driven. The voltage is specified in millivolts; i.e. a voltage value of 3000 would set the heater voltage to 3.000V. The response is **{byteCount}{status}**.
- :PDw {period}; Writes the periodic rate at which data is reported from the SMOD701. The period is specified in deciseconds (i.e., a period value of 20 would set a 2-second period). The response is **{byteCount}{status}**.
- :PDr; Reads the periodic rate setting in the SMOD701. The response is **{byteCount}{status}{period}**, where the period is specified in deciseconds.
- :GD; Instructs the module to return the last data set, consisting of values as shown in Table 6.

Table 6. Data Message Format

Offset in Response	Data Type	Contents
0	Unsigned 8-bit integer	byteCount
1	Unsigned 16-bit integer	Status
3	Unsigned 8-bit integer	Data set identifier ('d')
4	Unsigned 8-bit integer	Data set identifier ('2')
5	Unsigned 16-bit integer	Sequence count (starts from zero at power-up and increments with each data point collected)
7	Unsigned 8-bit integer	Heater control method (0 = voltage, 1 = resistance, 2 = power, 255 = current)
8	Unsigned 16-bit integer	Heater value (voltage in mV)
10	Unsigned 32-bit integer	Sensor resistance (ohms)
14	Unsigned 8-bit integer	Sequence (high nibble = total steps in sequence; low nibble = active step)
15	Unsigned 16-bit integer	Analysis result (linear response proportional to ppm of hydrogen)

3.6 Sensor Replacement



Important Safety Warning: Power should be removed from the board during any sensor replacement operation. Sensor heaters are subject to damage if inserted while being driven by heater current, and sensor packages at operating temperatures might be hot to the touch. Always use caution when handling sensors.

Removing the sensor on the SMOD701 is accomplished by gripping the sensor on each side and then pulling gently straight up from the module. To insert a sensor, align the sensor tab with the silkscreen indicator and then gently push the sensor pins into the socket.

4. Package Outline Drawing

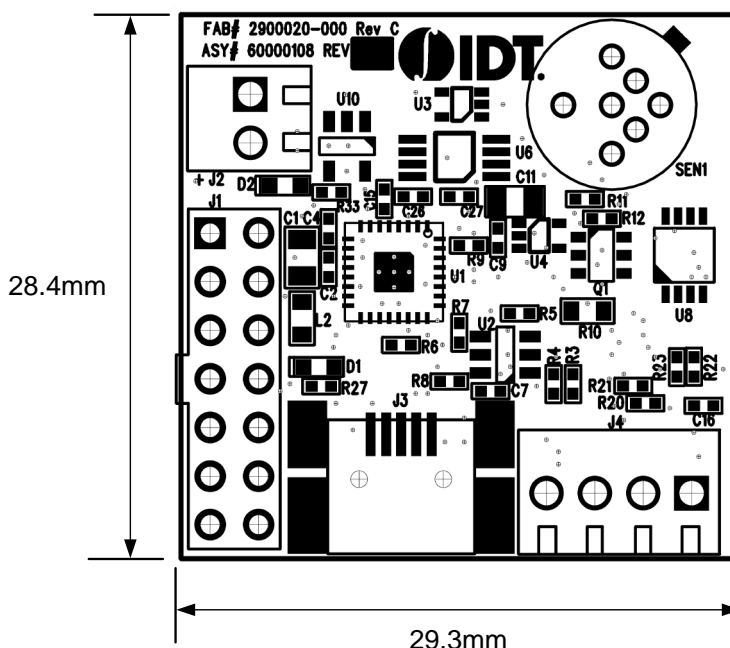

Figure 6. Package Outline Drawing and Dimensions

5. Ordering Information

Part Number	Description	Package	Carrier Type	Temp. Range
SMOD701	SMOD701 H ₂ Sensor Module with USB Interface	Module	Box	0°C to 50°C

6. Revision History

Revision	Date	Description
1.1	Apr 13, 2021	<ul style="list-style-type: none">▪ Added uart settings▪ Removed I²C option▪ Completed other minor corrections▪ Updated document to the latest template
1.0	Aug 9, 2017	Initial release.

IMPORTANT NOTICE AND DISCLAIMER

RENESAS ELECTRONICS CORPORATION AND ITS SUBSIDIARIES (“RENESAS”) PROVIDES TECHNICAL SPECIFICATIONS AND RELIABILITY DATA (INCLUDING DATASHEETS), DESIGN RESOURCES (INCLUDING REFERENCE DESIGNS), APPLICATION OR OTHER DESIGN ADVICE, WEB TOOLS, SAFETY INFORMATION, AND OTHER RESOURCES “AS IS” AND WITH ALL FAULTS, AND DISCLAIMS ALL WARRANTIES, EXPRESS OR IMPLIED, INCLUDING, WITHOUT LIMITATION, ANY IMPLIED WARRANTIES OF MERCHANTABILITY, FITNESS FOR A PARTICULAR PURPOSE, OR NON-INFRINGEMENT OF THIRD-PARTY INTELLECTUAL PROPERTY RIGHTS.

These resources are intended for developers who are designing with Renesas products. You are solely responsible for (1) selecting the appropriate products for your application, (2) designing, validating, and testing your application, and (3) ensuring your application meets applicable standards, and any other safety, security, or other requirements. These resources are subject to change without notice. Renesas grants you permission to use these resources only to develop an application that uses Renesas products. Other reproduction or use of these resources is strictly prohibited. No license is granted to any other Renesas intellectual property or to any third-party intellectual property. Renesas disclaims responsibility for, and you will fully indemnify Renesas and its representatives against, any claims, damages, costs, losses, or liabilities arising from your use of these resources. Renesas' products are provided only subject to Renesas' Terms and Conditions of Sale or other applicable terms agreed to in writing. No use of any Renesas resources expands or otherwise alters any applicable warranties or warranty disclaimers for these products.

(Disclaimer Rev.1.01)

Corporate Headquarters

TOYOSU FORESIA, 3-2-24 Toyosu,
Koto-ku, Tokyo 135-0061, Japan
www.renesas.com

Trademarks

Renesas and the Renesas logo are trademarks of Renesas Electronics Corporation. All trademarks and registered trademarks are the property of their respective owners.

Contact Information

For further information on a product, technology, the most up-to-date version of a document, or your nearest sales office, please visit www.renesas.com/contact-us/.