

# R1EV58064BxxN Series

# R1EV58064BxxR Series

64K EEPROM (8-Kword × 8-bit)  
 Ready/Busy function  
 RES function (R1EV58064BxxR)

R10DS0207EJ0201  
 Rev.2.01  
 Apr. 01, 2020

## Description

Renesas Electronics' R1EV58064BxxN series and R1EV58064BxxR series are electrically erasable and programmable EEPROM's organized as 8192-word × 8-bit. They have realized high speed, low power consumption and high reliability by employing advanced MONOS memory technology and CMOS process and circuitry technology. They also have a 64-byte page programming function to make their write operations faster.

## Features

- Single supply: 2.7 to 5.5 V
- Access time:
  - 100 ns (max) at  $2.7\text{ V} \leq V_{CC} < 4.5\text{ V}$
  - 70 ns (max) at  $4.5\text{ V} \leq V_{CC} \leq 5.5\text{ V}$
- Power dissipation:
  - Active: 20 mW/MHz (typ)
  - Standby: 110  $\mu$ W (max)
- On-chip latches: address, data,  $\overline{CE}$ ,  $\overline{OE}$ ,  $\overline{WE}$
- Automatic byte write: 10 ms (max)
- Automatic page write (64 bytes): 10 ms (max)
- Ready/Busy
- Data polling and Toggle bit
- Data protection circuit on power on/off
- Conforms to JEDEC byte-wide standard
- Reliable CMOS with MONOS cell technology
- $10^5$  or more erase /write cycles
- 10 or more years data retention
- Software data protection
- Write protection by  $\overline{RES}$  pin (only the R1EV58064BxxR series)
- Temperature range: -40 to +85°C
- There are lead free products.

### Ordering Information

Orderable Part Name	Access time	Package	Shipping Container	Quantity
R1EV58064BDANBI#B*	100ns	600mil 28-pin plastic DiP PRDP0028AB-A (DP-28V)	Tube	Max. 13 pcs/tube
R1EV58064BDARBI#B*	100ns			Max. 325 pcs/inner box
R1EV58064BSCNBI#B*	100ns	400mil 28- pin plastic SOP PRSP0028DC-A (FP-28DV)	Tube	Max. 25 pcs/tube
R1EV58064BSCRBI#B*	100ns			Max. 1,000 pcs/inner box
R1EV58064BSCNBI#S*	100ns		Tape and reel	1,000 pcs/reel
R1EV58064BSCRBI#S*	100ns			
R1EV58064BTCNBI#B*	100ns	28-pin plastic TSOP PTSA0028ZB-A (TFP-28DBV)	Tray	Max. 60 pcs/tray
R1EV58064BTCRBI#B*	100ns			Max. 600 pcs/inner box

Notes 1. \*= Revision code (0,2 etc.)

### Pin Arrangement

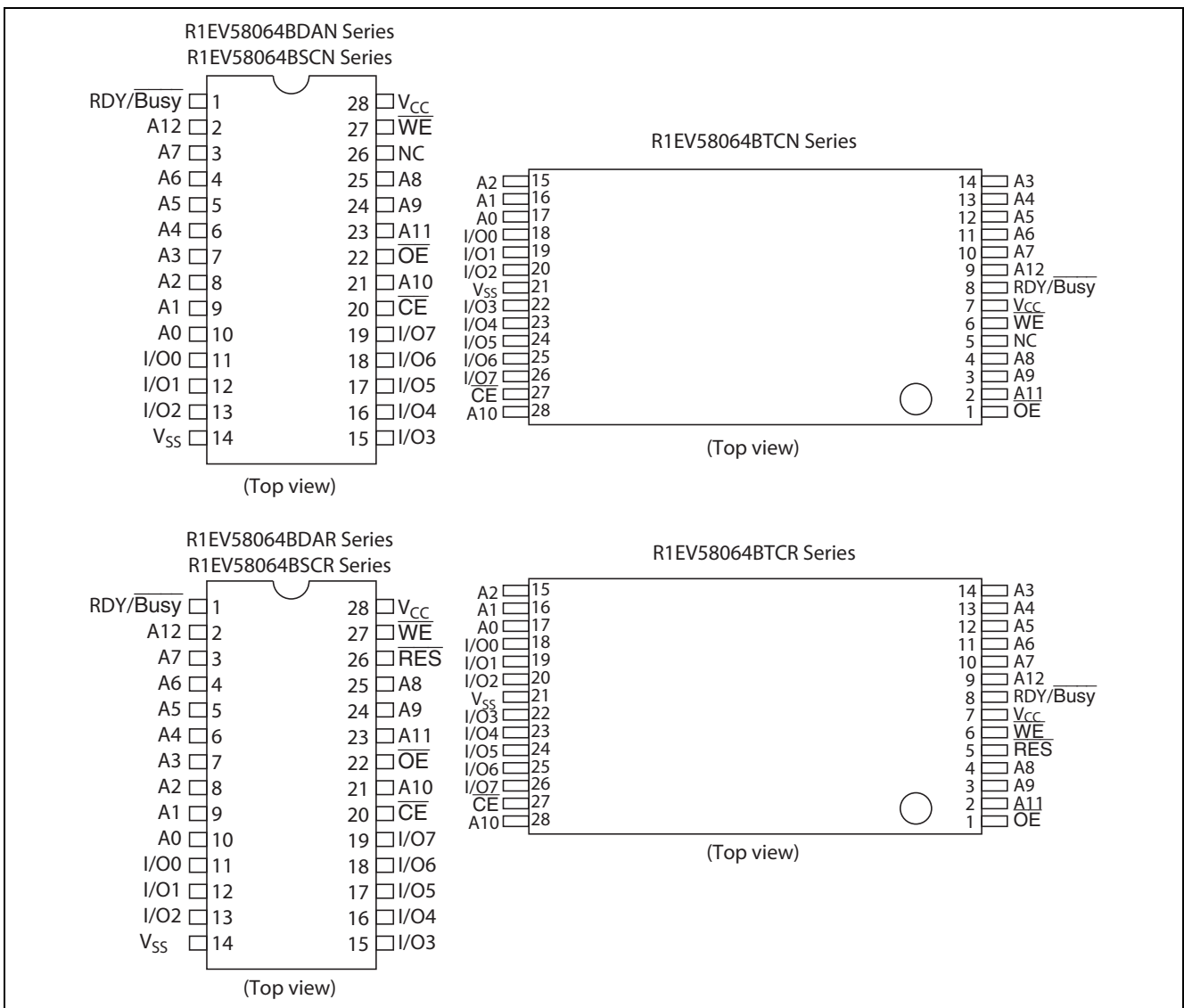

## Pin Description

Pin name	Function
A0 to A12	Address input
I/O0 to I/O7	Data input/output
$\overline{OE}$	Output enable
$\overline{CE}$	Chip enable
$\overline{WE}$	Write enable
V <sub>CC</sub>	Power supply
V <sub>SS</sub>	Ground
$\overline{RDY/Busy}$	Ready busy
$\overline{RES}^{*1}$	Reset
NC	No connection

Note: 1. This function is supported by only the R1EV58064BxxR series.

## Block Diagram

Note: 1. This function is supported by only the R1EV58064BxxR series.

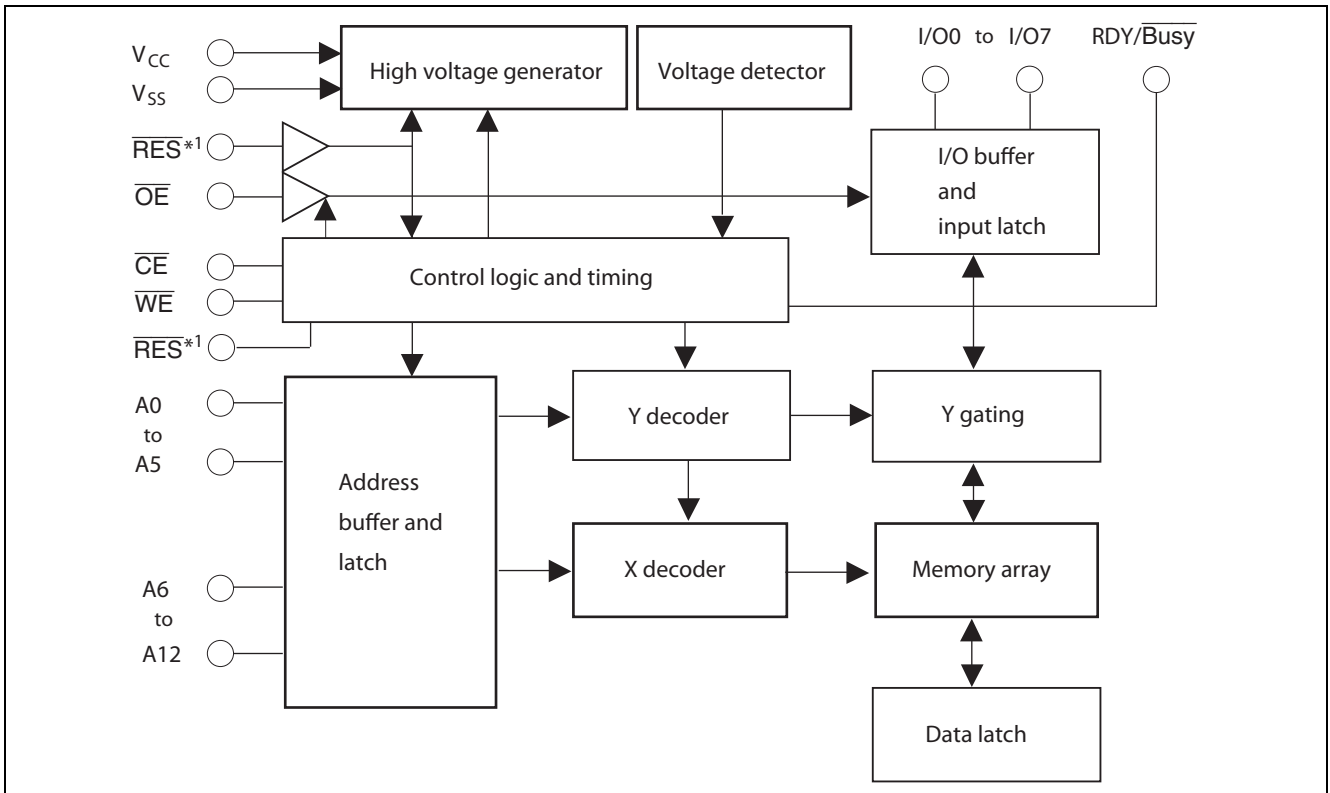

## Operation Table

Operation	$\overline{CE}$	$\overline{OE}$	$\overline{WE}$	$\overline{RES}^{*3}$	RDY/ $\overline{Busy}$	I/O
Read	V <sub>IL</sub>	V <sub>IL</sub>	V <sub>IH</sub>	V <sub>H</sub> *1	High-Z	Dout
Standby	V <sub>IH</sub>	x*2	x	x	High-Z	High-Z
Write	V <sub>IL</sub>	V <sub>IH</sub>	V <sub>IL</sub>	V <sub>H</sub>	High-Z to V <sub>OL</sub>	Din
Deselect	V <sub>IL</sub>	V <sub>IH</sub>	V <sub>IH</sub>	V <sub>H</sub>	High-Z	High-Z
Write Inhibit	x	x	V <sub>IH</sub>	x	—	—
Write Inhibit	x	V <sub>IL</sub>	x	x	—	—
Data Polling	V <sub>IL</sub>	V <sub>IL</sub>	V <sub>IH</sub>	V <sub>H</sub>	V <sub>OL</sub>	Dout (I/O7)
Program reset	x	x	x	V <sub>IL</sub>	High-Z	High-Z

- Notes: 1. Refer to the recommended DC operating conditions.  
 2. x : Don't care  
 3. This function supported by only the R1EV58064BxxR series.

## Absolute Maximum Ratings

Parameter	Symbol	Value	Unit
Power supply voltage relative to V <sub>SS</sub>	V <sub>CC</sub>	-0.6 to +7.0	V
Input voltage relative to V <sub>SS</sub>	V <sub>in</sub>	-0.5*1 to +7.0*3	V
Operating temperature range *2	T <sub>opr</sub>	-40 to +85	°C
Storage temperature range	T <sub>stg</sub>	-55 to +125	°C

- Notes: 1. V<sub>in</sub> min : -3.0 V for pulse width ≤ 50 ns.  
 2. Including electrical characteristics and data retention.  
 3. Should not exceed V<sub>CC</sub> + 1 V.

## Recommended DC Operating Conditions

Parameter	Symbol	Min	Typ	Max	Unit
Supply voltage	V <sub>CC</sub>	2.7	—	5.5	V
	V <sub>SS</sub>	0	0	0	V
Input voltage*6	V <sub>IL</sub>	-0.3*1	—	0.6*5	V
	V <sub>IH</sub>	2.4*2	—	V <sub>CC</sub> + 0.3*3	V
	V <sub>H</sub> *4	V <sub>CC</sub> - 0.5	—	V <sub>CC</sub> + 1.0	V
Operating temperature	T <sub>opr</sub>	-40	—	+85	°C

- Notes: 1. V<sub>IL</sub> min: -1.0 V for pulse width ≤ 50 ns.  
 2. V<sub>IH</sub> = 3.0 V for V<sub>CC</sub> = 3.6 to 5.5 V.  
 3. V<sub>IH</sub> max: V<sub>CC</sub> + 1.0 V for pulse width ≤ 50 ns.  
 4. This function is supported by only the R1EV58064BxxR series.  
 5. V<sub>IL</sub> = 0.8 V for V<sub>CC</sub> = 3.6 V to 5.5 V  
 6. Refer to the recommended AC operating condition during read and write operation.

**DC Characteristics**(Ta = -40 to +85°C, V<sub>CC</sub> = 2.7 to 5.5 V)

Parameter	Symbol	Min	Typ	Max	Unit	Test conditions
Input leakage current	I <sub>LI</sub>	—	—	2*1	μA	V <sub>CC</sub> = 5.5 V, V <sub>in</sub> = 5.5 V
Output leakage current	I <sub>LO</sub>	—	—	2	μA	V <sub>CC</sub> = 5.5 V, V <sub>out</sub> = 5.5/0.4 V
Standby V <sub>CC</sub> current	I <sub>CC1</sub>	—	1 to 2	5	μA	$\overline{CE} = V_{CC}$
	I <sub>CC2</sub>	—	—	1	mA	$\overline{CE} = V_{IH}$
Operating V <sub>CC</sub> current	I <sub>CC3</sub>	—	—	6	mA	I <sub>out</sub> = 0 mA, Duty = 100%, Cycle = 1 μs at V <sub>CC</sub> = 3.6 V
		—	—	10	mA	I <sub>out</sub> = 0 mA, Duty = 100%, Cycle = 1 μs at V <sub>CC</sub> = 5.5 V
		—	—	15	mA	I <sub>out</sub> = 0 mA, Duty = 100%, Cycle = 100 ns at V <sub>CC</sub> = 3.6 V
		—	—	25	mA	I <sub>out</sub> = 0 mA, Duty = 100%, Cycle = 70 ns at V <sub>CC</sub> = 5.5 V
Output low voltage	V <sub>OL</sub>	—	—	0.4	V	I <sub>OL</sub> = 2.1 mA
Output high voltage	V <sub>OH</sub>	V <sub>CC</sub> × 0.8	—	—	V	I <sub>OH</sub> = -400 μA

Note: 1. I<sub>LI</sub> on RES : 100 μA max (only the R1EV58064BxxR series)**Capacitance**

(Ta = +25°C, f = 1 MHz)

Parameter	Symbol	Min	Typ	Max	Unit	Test conditions
Input capacitance	C <sub>in</sub> *1	—	—	6	pF	V <sub>in</sub> = 0 V
Output capacitance	C <sub>out</sub> *1	—	—	12	pF	V <sub>out</sub> = 0 V

Note: 1. This parameter is sampled and not 100% tested.

## AC Characteristics

 $T_a = -40 \text{ to } +85^\circ\text{C}$ ,  $V_{CC} = 2.7 \text{ to } 5.5 \text{ V}$ 

### Test Conditions

- Input pulse levels : 0.4 V to 2.4 V ( $V_{CC} = 2.7 \text{ to } 3.6 \text{ V}$ ), 0.4 V to 3.0 V ( $V_{CC} = 3.6 \text{ to } 5.5 \text{ V}$ )  
0 V to  $V_{CC}$  (RES pin\*2)
- Input rise and fall time :  $\leq 5 \text{ ns}$
- Input timing reference levels : 0.8, 1.8 V
- Output load : 1TTL Gate +100 pF
- Output reference levels : 1.5 V, 1.5 V

### Read Cycle 1 ( $2.7 \leq V_{CC} < 4.5 \text{ V}$ )

Parameter	Symbol	Min	Max	Unit	Test conditions
Address to output delay	$t_{ACC}$	—	100	ns	$\overline{CE} = \overline{OE} = V_{IL}$ , $\overline{WE} = V_{IH}$
$\overline{CE}$ to output delay	$t_{CE}$	—	100	ns	$\overline{OE} = V_{IL}$ , $\overline{WE} = V_{IH}$
$\overline{OE}$ to output delay	$t_{OE}$	10	50	ns	$\overline{CE} = V_{IL}$ , $\overline{WE} = V_{IH}$
Address to output hold	$t_{OH}$	0	—	ns	$\overline{CE} = \overline{OE} = V_{IL}$ , $\overline{WE} = V_{IH}$
$\overline{OE}$ ( $\overline{CE}$ ) high to output float*1	$t_{DF}$	0	40	ns	$\overline{CE} = V_{IL}$ , $\overline{WE} = V_{IH}$
$\overline{RES}$ low to output float*1, 2	$t_{DFR}$	0	350	ns	$\overline{CE} = \overline{OE} = V_{IL}$ , $\overline{WE} = V_{IH}$
$\overline{RES}$ to output delay*2	$t_{RR}$	0	450	ns	$\overline{CE} = \overline{OE} = V_{IL}$ , $\overline{WE} = V_{IH}$

### Write Cycle 1 ( $2.7 \leq V_{CC} < 4.5 \text{ V}$ )

Parameter	Symbol	Min*3	Typ	Max	Unit	Test conditions
Address setup time	$t_{AS}$	0	—	—	ns	
Address hold time	$t_{AH}$	50	—	—	ns	
$\overline{CE}$ to write setup time ( $\overline{WE}$ controlled)	$t_{CS}$	0	—	—	ns	
$\overline{CE}$ hold time ( $\overline{WE}$ controlled)	$t_{CH}$	0	—	—	ns	
$\overline{WE}$ to write setup time ( $\overline{CE}$ controlled)	$t_{WS}$	0	—	—	ns	
$\overline{WE}$ hold time ( $\overline{CE}$ controlled)	$t_{WH}$	0	—	—	ns	
$\overline{OE}$ to write setup time	$t_{OES}$	0	—	—	ns	
$\overline{OE}$ hold time	$t_{OEH}$	0	—	—	ns	
Data setup time	$t_{DS}$	50	—	—	ns	
Data hold time	$t_{DH}$	0	—	—	ns	
$\overline{WE}$ pulse width ( $\overline{WE}$ controlled)	$t_{WP}$	0.200	—	30	$\mu\text{s}$	
$\overline{CE}$ pulse width ( $\overline{CE}$ controlled)	$t_{CW}$	0.200	—	30	$\mu\text{s}$	
Data latch time	$t_{DL}$	100	—	—	ns	
Byte load cycle	$t_{BLC}$	0.3	—	30	$\mu\text{s}$	
Byte load window	$t_{BL}$	100	—	—	$\mu\text{s}$	
Write cycle time	$t_{WC}$	—	—	$10^{*4}$	ms	
Time to device busy	$t_{DB}$	120	—	—	ns	
Write start time	$t_{DW}$	$0^{*5}$	—	—	ns	
Reset protect time*2	$t_{RP}$	100	—	—	$\mu\text{s}$	
Reset high time*2, 6	$t_{RES}$	1	—	—	$\mu\text{s}$	

Notes: 1.  $t_{DF}$  and  $t_{DFR}$  are defined as the time at which the outputs achieve the open circuit conditions and are no longer driven.

2. This function is supported by only the R1EV58064BxxR series.

3. Use this device in longer cycle than this value.

4.  $t_{WC}$  must be longer than this value unless polling techniques or  $\overline{RDY}/\overline{Busy}$  are used. This device automatically completes the internal write operation within this value.

5. Next read or write operation can be initiated after  $t_{DW}$  if polling techniques or  $\overline{RDY}/\overline{Busy}$  are used.

6. This parameter is sampled and not 100% tested.

7. A6 through A12 are page addresses and these addresses are latched at the first falling edge of  $\overline{WE}$ .

8. A6 through A12 are page addresses and these addresses are latched at the first falling edge of  $\overline{CE}$ .

9. See AC read characteristics.

**Read Cycle 2** ( $4.5 \leq V_{CC} \leq 5.5$  V)

Parameter	Symbol	Min	Max	Unit	Test conditions
Address to output delay	$t_{ACC}$	—	70	ns	$\overline{CE} = \overline{OE} = V_{IL}, \overline{WE} = V_{IH}$
$\overline{CE}$ to output delay	$t_{CE}$	—	70	ns	$\overline{OE} = V_{IL}, \overline{WE} = V_{IH}$
$\overline{OE}$ to output delay	$t_{OE}$	10	40	ns	$\overline{CE} = V_{IL}, \overline{WE} = V_{IH}$
Address to output hold	$t_{OH}$	0	—	ns	$\overline{CE} = \overline{OE} = V_{IL}, \overline{WE} = V_{IH}$
$\overline{OE}$ (CE) high to output float* <sup>1</sup>	$t_{DF}$	0	30	ns	$\overline{CE} = V_{IL}, \overline{WE} = V_{IH}$
$\overline{RES}$ low to output float* <sup>1, 2</sup>	$t_{DFR}$	0	350	ns	$\overline{CE} = \overline{OE} = V_{IL}, \overline{WE} = V_{IH}$
$\overline{RES}$ to output delay* <sup>2</sup>	$t_{RR}$	0	450	ns	$\overline{CE} = \overline{OE} = V_{IL}, \overline{WE} = V_{IH}$

**Write Cycle 2** ( $4.5 \leq V_{CC} \leq 5.5$  V)

Parameter	Symbol	Min* <sup>3</sup>	Typ	Max	Unit	Test conditions
Address setup time	$t_{AS}$	0	—	—	ns	
Address hold time	$t_{AH}$	50	—	—	ns	
$\overline{CE}$ to write setup time ( $\overline{WE}$ controlled)	$t_{CS}$	0	—	—	ns	
$\overline{CE}$ hold time ( $\overline{WE}$ controlled)	$t_{CH}$	0	—	—	ns	
$\overline{WE}$ to write setup time ( $\overline{CE}$ controlled)	$t_{WS}$	0	—	—	ns	
$\overline{WE}$ hold time ( $\overline{CE}$ controlled)	$t_{WH}$	0	—	—	ns	
$\overline{OE}$ to write setup time	$t_{OES}$	0	—	—	ns	
$\overline{OE}$ hold time	$t_{OEH}$	0	—	—	ns	
Data setup time	$t_{DS}$	50	—	—	ns	
Data hold time	$t_{DH}$	0	—	—	ns	
$\overline{WE}$ pulse width ( $\overline{WE}$ controlled)	$t_{WP}$	0.100	—	30	$\mu$ s	
$\overline{CE}$ pulse width ( $\overline{CE}$ controlled)	$t_{CW}$	0.100	—	30	$\mu$ s	
Data latch time	$t_{DL}$	50	—	—	ns	
Byte load cycle	$t_{BLC}$	0.2	—	30	$\mu$ s	
Byte load window	$t_{BL}$	100	—	—	$\mu$ s	
Write cycle time	$t_{WC}$	—	—	10* <sup>4</sup>	ms	
Time to device busy	$t_{DB}$	120	—	—	ns	
Write start time	$t_{DW}$	0* <sup>5</sup>	—	—	ns	
Reset protect time* <sup>2</sup>	$t_{RP}$	100	—	—	$\mu$ s	
Reset high time* <sup>2, 6</sup>	$t_{RES}$	1	—	—	$\mu$ s	

Notes: 1.  $t_{DF}$  and  $t_{DFR}$  are defined as the time at which the outputs achieve the open circuit conditions and are no longer driven.

2. This function is supported by only the R1EV58064BXXR.

3. Use this device in longer cycle than this value.

4.  $t_{WC}$  must be longer than this value unless polling techniques or  $\overline{RDY}/\overline{Busy}$  are used. This device automatically completes the internal write operation within this value.

5. Next read or write operation can be initiated after  $t_{DW}$  if polling techniques or  $\overline{RDY}/\overline{Busy}$  are used.

6. This parameter is sampled and not 100% tested.

7. A6 through A12 are page address and these addresses are latched at the first falling edge of  $\overline{WE}$ .

8. A6 through A12 are page address and these addresses are latched at the first falling edge of  $\overline{CE}$ .

9. See AC read characteristics.

## Timing Waveforms

### Read Timing Waveform

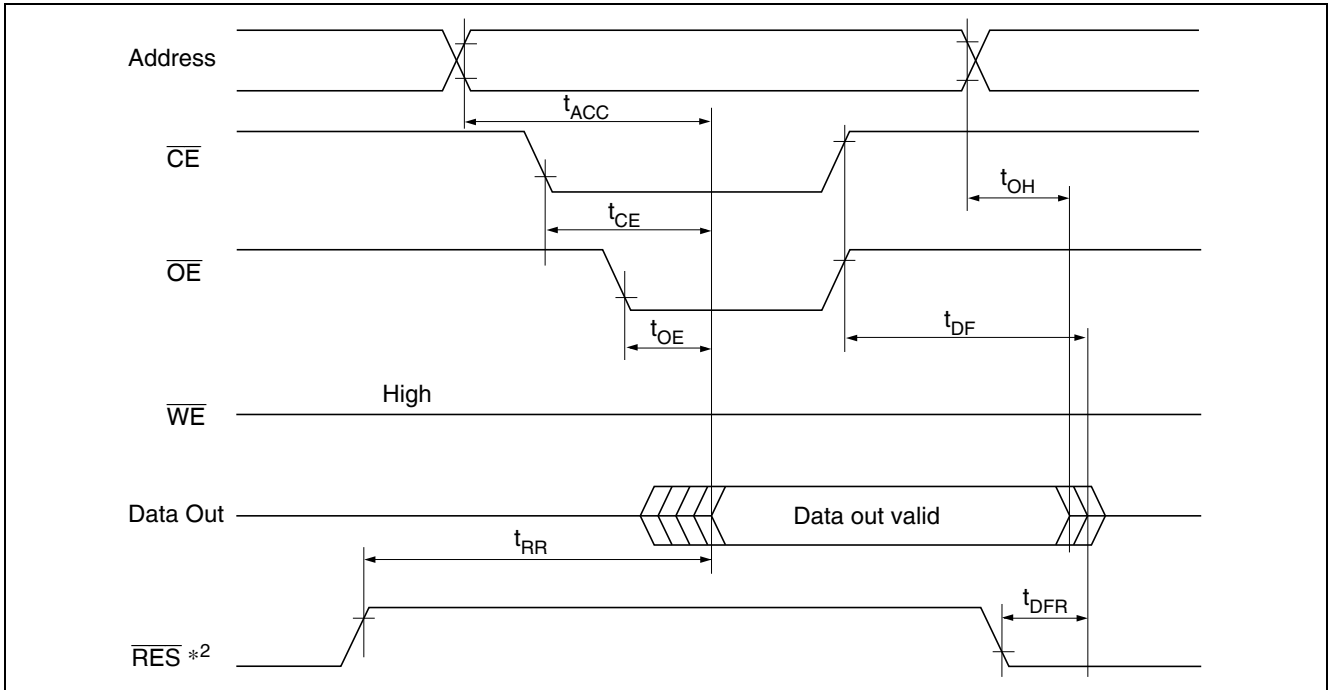



**Byte Write Timing Waveform(1) ( $\overline{WE}$  Controlled)**

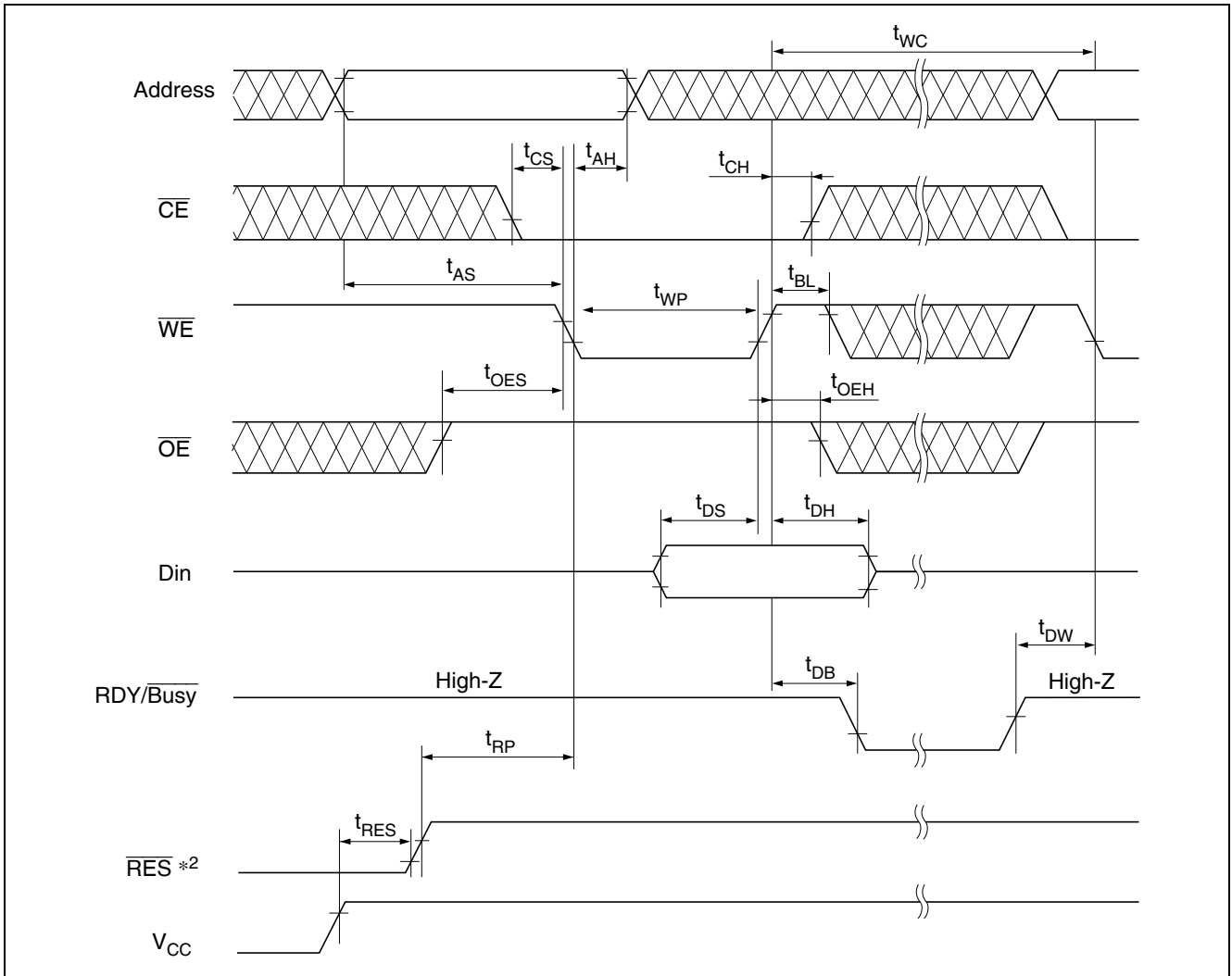

**Byte Write Timing Waveform(2) ( $\overline{CE}$  Controlled)**

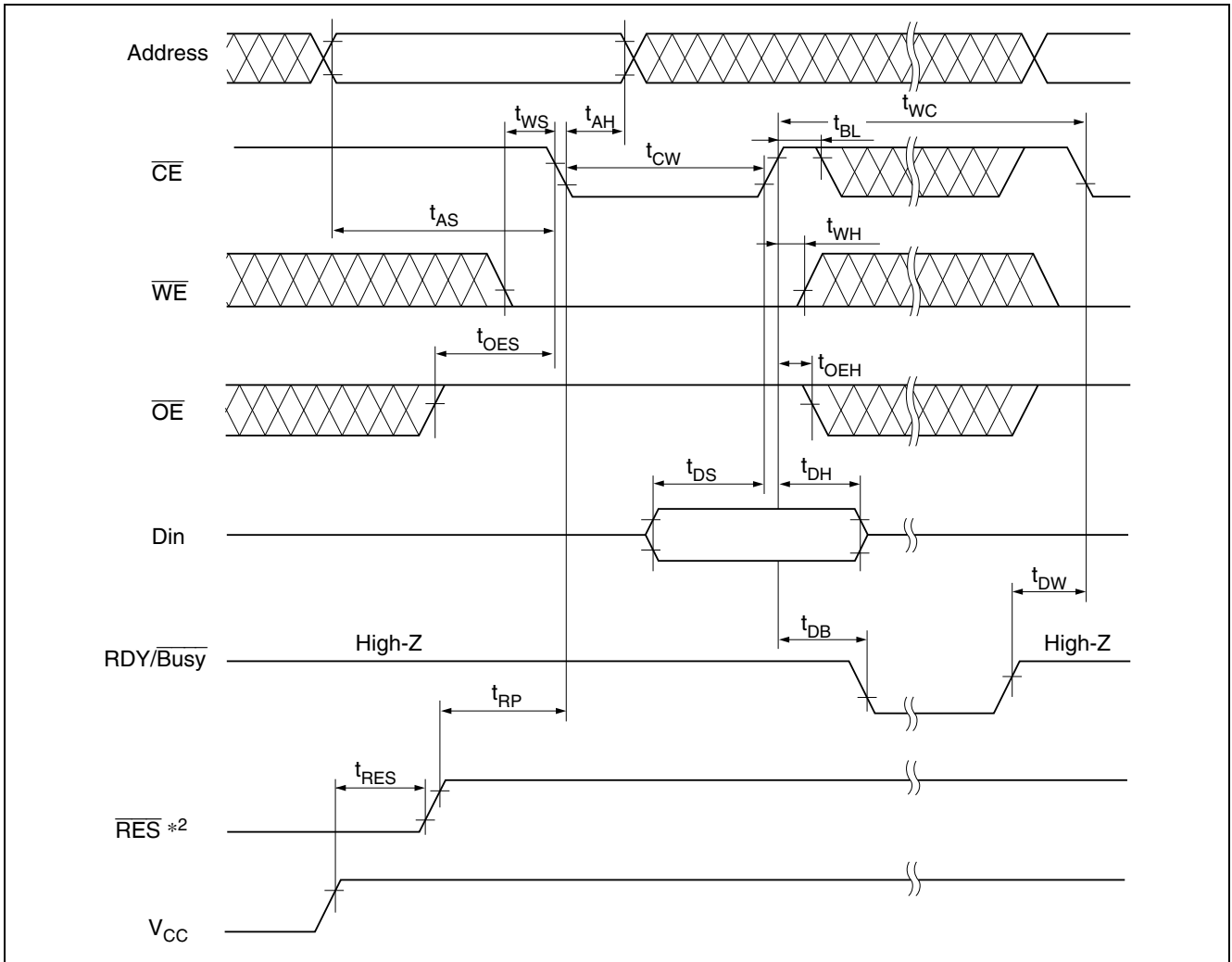

Page Write Timing Waveform(1) ( $\overline{WE}$  Controlled)

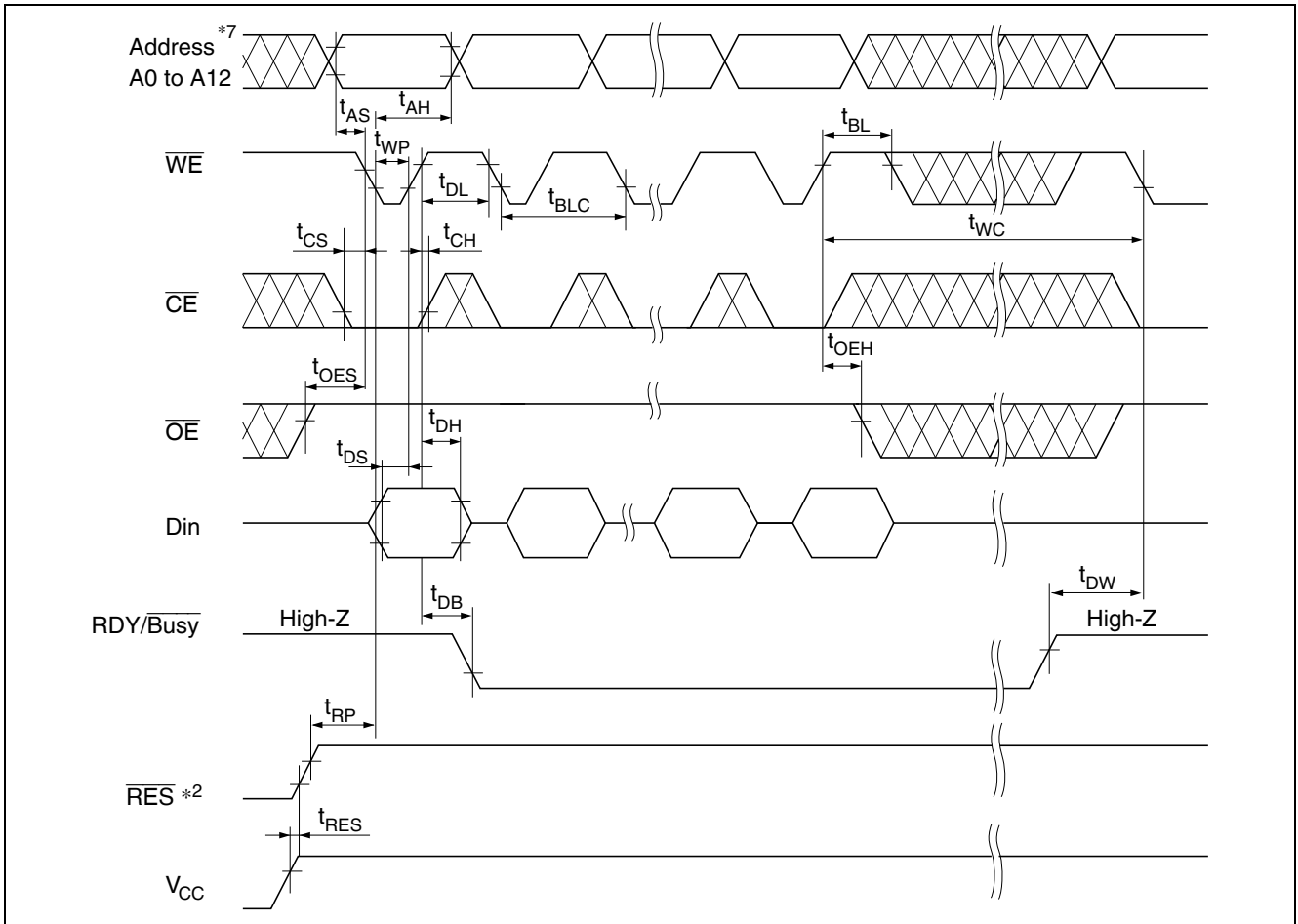

Page Write Timing Waveform(2) ( $\overline{CE}$  Controlled)

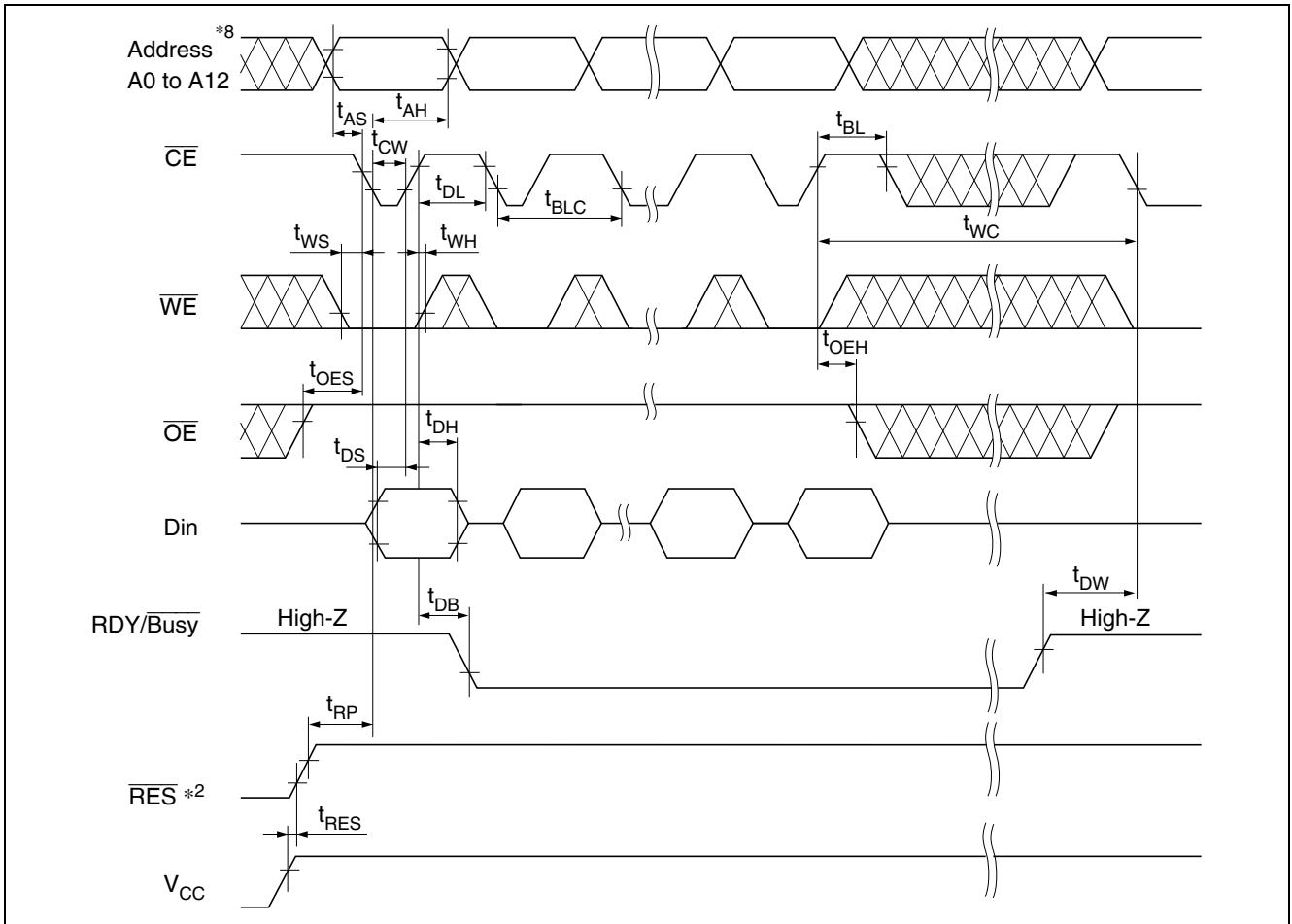



### Toggle Bit

This device provide another function to determine the internal programming cycle. If the EEPROM is set to read mode during the internal programming cycle, I/O6 will charge from “1” to “0” (togglng) for each read. When the internal programming cycle is finished, toggling of I/O6 will stop and the device can be accessible for next read or program.

### Toggle Bit Waveform

- Notes: 1. I/O6 beginning state is “1”.
2. I/O6 ending state will vary.
3. See AC read characteristics.
4. Any address location can be used, but the address must be fixed.

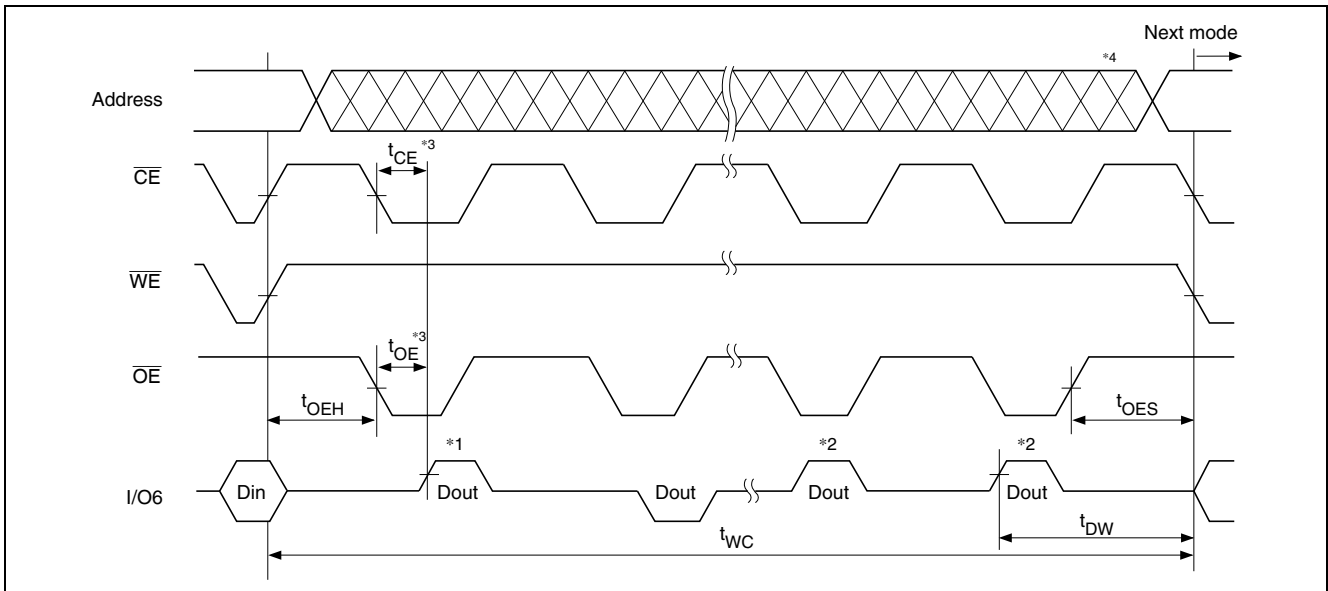

**Software Data Protection Timing Waveform(1)** (in protection mode)

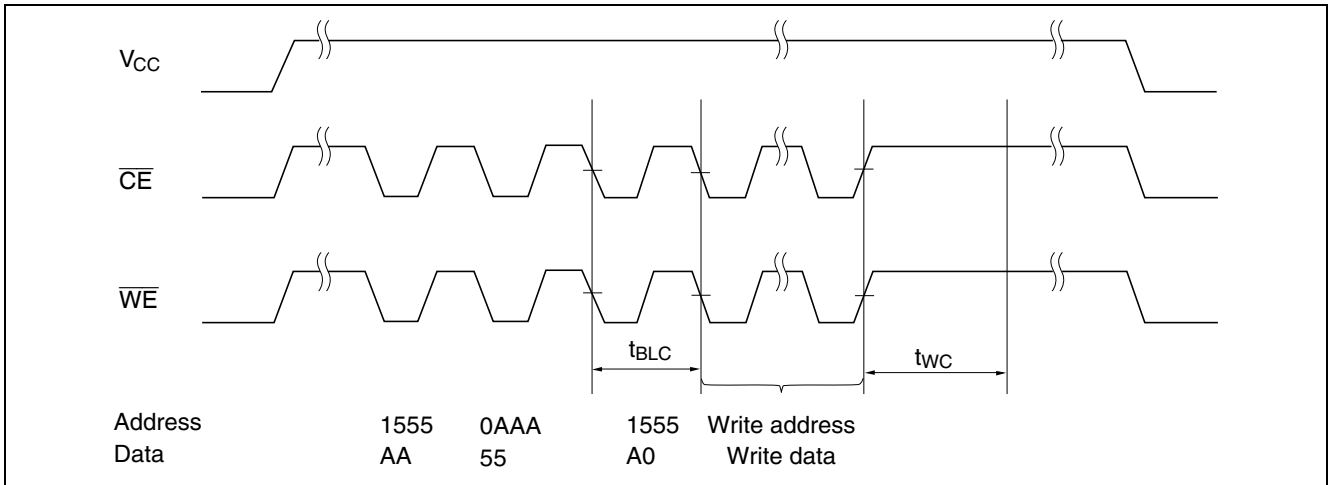

**Software Data Protection Timing Waveform(2)** (in non-protection mode)

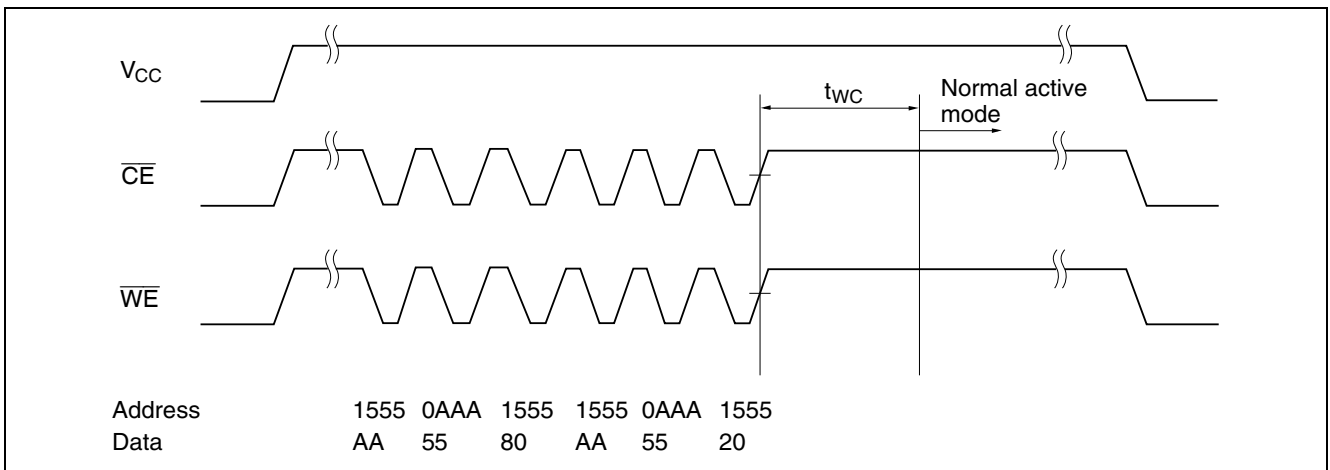

## Functional Description

### Automatic Page Write

Page-mode write feature allows 1 to 64 bytes of data to be written into the EEPROM in a single write cycle. Following the initial byte cycle, an additional 1 to 63 bytes can be written in the same manner. Each additional byte load cycle must be started within 30  $\mu$ s from the preceding falling edge of  $\overline{WE}$  or  $\overline{CE}$ . When  $\overline{CE}$  or  $\overline{WE}$  is kept high for 100  $\mu$ s after data input, the EEPROM enters write mode automatically and the input data are written into the EEPROM.

### Data Polling

Data polling indicates the status that the EEPROM is in a write cycle or not. If EEPROM is set to read mode during a write cycle, an inversion of the last byte of data outputs from I/O7 to indicate that the EEPROM is performing a write operation.

### RDY/ $\overline{Busy}$ Signal

RDY/ $\overline{Busy}$  signal also allows status of the EEPROM to be determined. The RDY/ $\overline{Busy}$  signal has high impedance except in write cycle and is lowered to  $V_{OL}$  after the first write signal. At the end of a write cycle, the RDY/ $\overline{Busy}$  signal changes state to high impedance.

### $\overline{RES}$ Signal (only the R1EV58064BxxR series)

When  $\overline{RES}$  is low, the EEPROM cannot be read or programmed. Therefore, data can be protected by keeping  $\overline{RES}$  low when  $V_{CC}$  is switched.  $\overline{RES}$  should be high during read and programming because it doesn't provide a latch function.

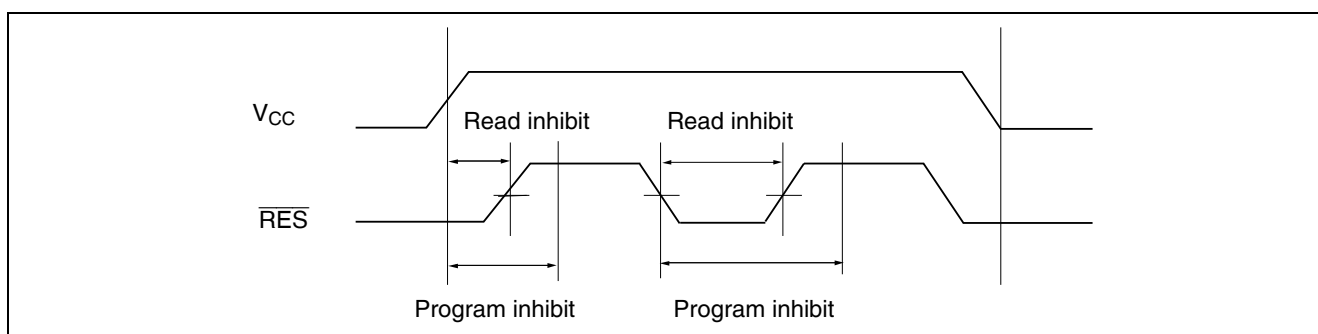



## $\overline{WE}$ , $\overline{CE}$ Pin Operation

During a write cycle, addresses are latched by the falling edge of  $\overline{WE}$  or  $\overline{CE}$ , and data is latched by the rising edge of  $\overline{WE}$  or  $\overline{CE}$ .

## Write/Erase Endurance and Data Retention Time

The endurance is  $10^5$  cycles (1% cumulative failure rate). The data retention time is more than 10 years.

## Data Protection

To prevent this phenomenon, this device has a noise cancellation function that cuts noise if its width is 15 ns or less.

### 1. Data Protection against Noise on Control Pins ( $\overline{CE}$ , $\overline{OE}$ , $\overline{WE}$ ) during Operation

During readout or standby, noise on the control pins may act as a trigger and turn the EEPROM to programming mode by mistake. Be careful not to allow noise of a width of more than 15 ns on the control pins.

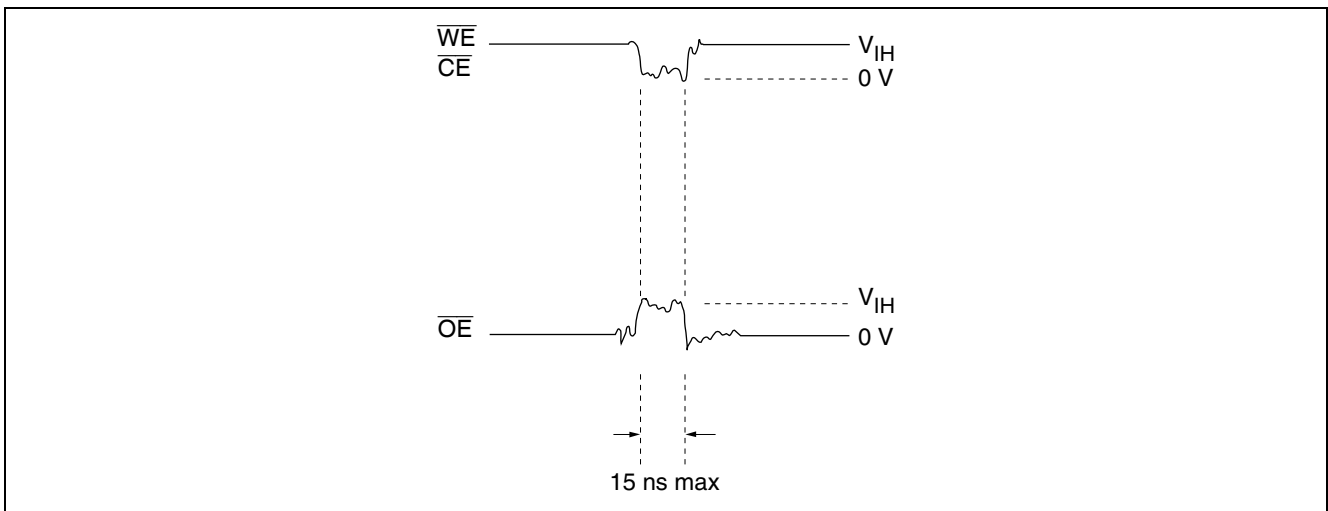

2. Data protection at  $V_{CC}$  on/off

When  $V_{CC}$  is turned on or off, noise on the control pins generated by external circuits (CPU, etc) may act as a trigger and turn the EEPROM to program mode by mistake. To prevent this unintentional programming, the EEPROM must be kept in an unprogrammable state while the CPU is in an unstable state.

Note: The EEPROM should be kept in unprogrammable state during  $V_{CC}$  on/off by using CPU RESET signal.

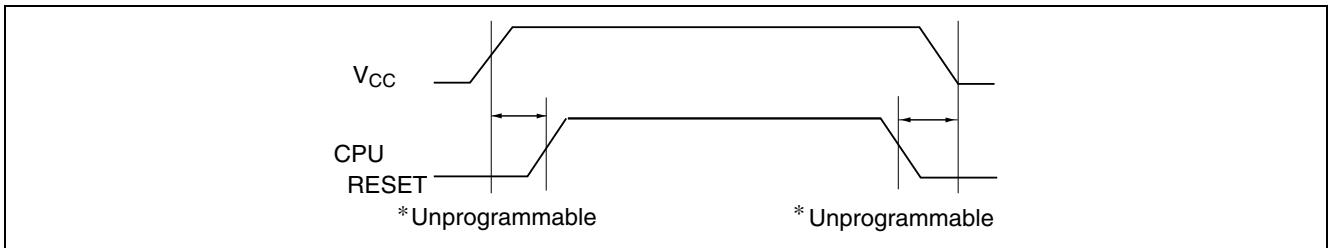

2.1 Protection by  $\overline{CE}$ ,  $\overline{OE}$ ,  $\overline{WE}$

To realize the unprogrammable state, the input level of control pins must be held as shown in the table below.

$\overline{CE}$	$V_{CC}$	x	x
$\overline{OE}$	x	$V_{SS}$	x
$\overline{WE}$	x	x	$V_{CC}$

x: Don't care.

$V_{CC}$ : Pull-up to  $V_{CC}$  level.

$V_{SS}$ : Pull-down to  $V_{SS}$  level.

2.2 Protection by  $\overline{RES}$  (only the R1EV58064BXXR series)

The unprogrammable state can be realized by that the CPU's reset signal inputs directly to the EEPROM's  $\overline{RES}$  pin.  $\overline{RES}$  should be kept  $V_{SS}$  level during  $V_{CC}$  on/off. The EEPROM breaks off programming operation when  $\overline{RES}$  becomes low, programming operation doesn't finish correctly in case that  $\overline{RES}$  falls low during programming operation.  $\overline{RES}$  should be kept high for 10 ms after the last data input.

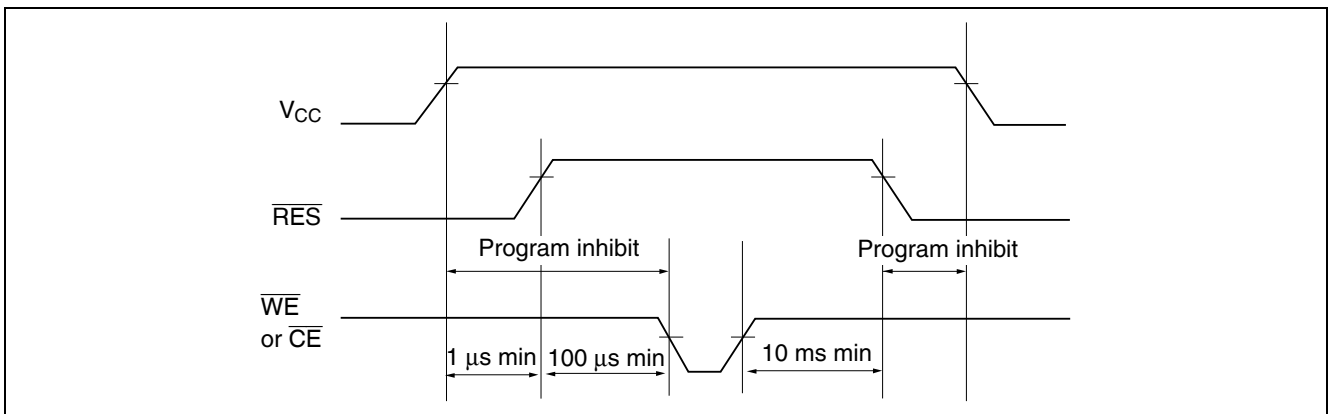

### 3. Software data protection

To prevent unintentional programming caused by noise generated by external circuits, this device has the software data protection function. In software data protection mode, 3 bytes of data must be input before write data as follows. And these bytes can switch the non-protection mode to the protection mode. SDP is enabled if only the 3 byte code is input.

Address	Data
1555	AA
↓	↓
0AAA	55
↓	↓
1555	A0
↓	↓
Write address	Write data } Normal data input

Software data protection mode can be canceled by inputting the following 6 bytes. After that, this device turns to the non-protection mode and can write data normally. But when the data is input in the canceling cycle, the data cannot be written.

Address	Data
1555	AA
↓	↓
0AAA	55
↓	↓
1555	80
↓	↓
1555	AA
↓	↓
0AAA	55
↓	↓
1555	20

The software data protection is not enabled at the shipment.

Note: There are some differences between Renesas Technology's and other company's for enable/disable sequence of software data protection. If there are any questions, please contact with Renesas Technology's sales offices.

**Orderable Part Number Guide**

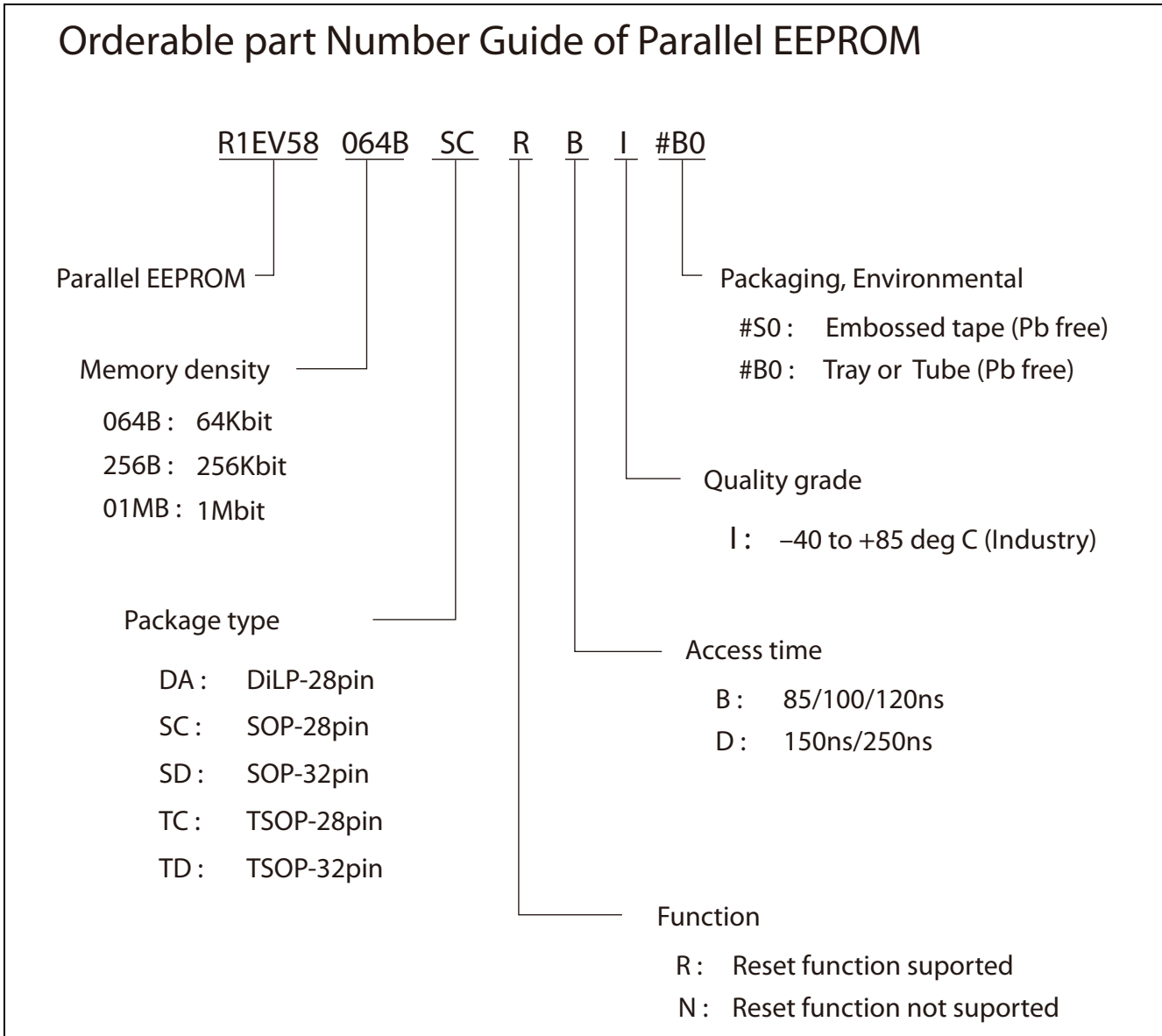

## Package Dimensions

### R1EV58064BDAN Series

### R1EV58064BDAR Series (PRDP0028AB-A / Previous Code: DP-28V)

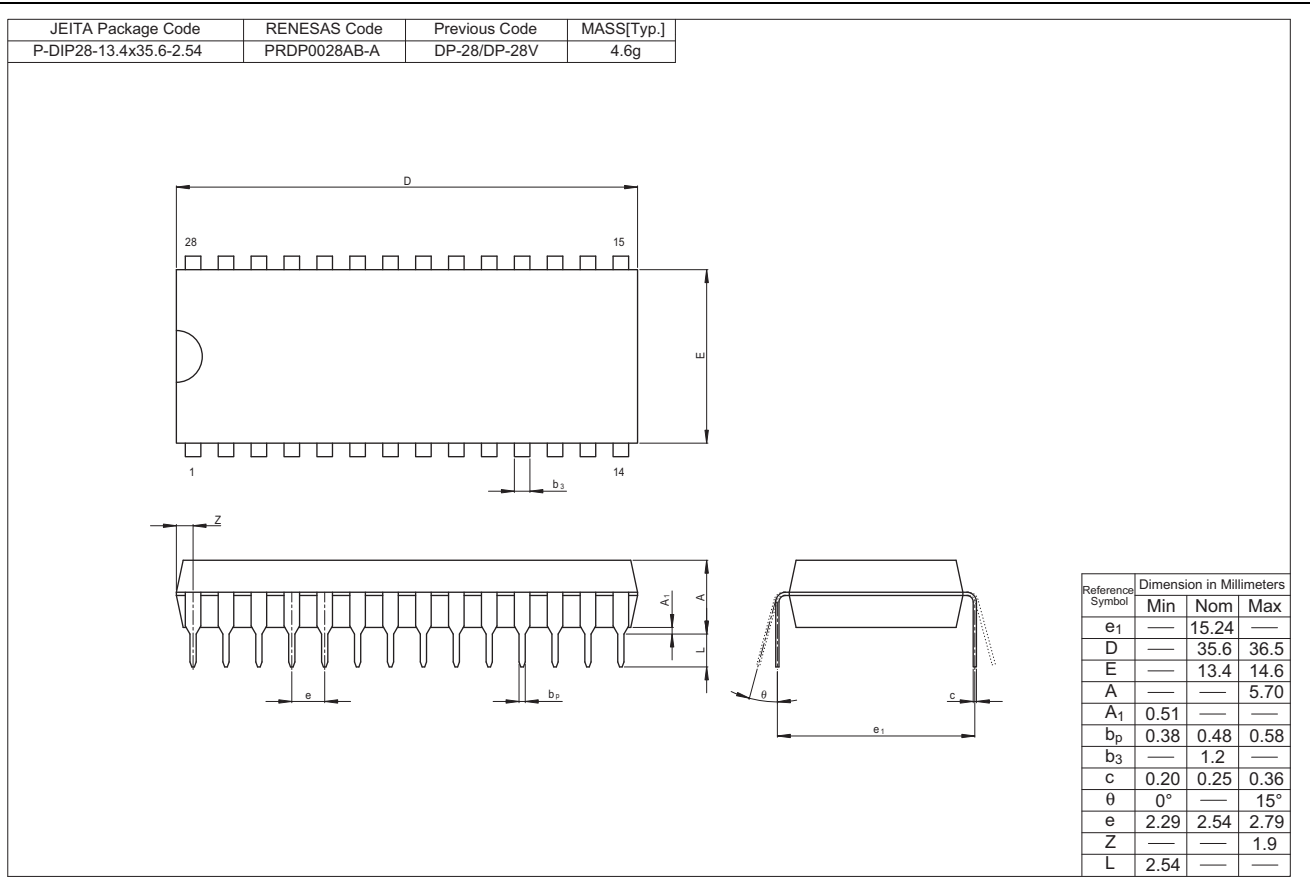

Package Dimensions (cont)

R1EV58064BSCN Series

R1EV58064BSCR Series (PRSP0028DC-A / Previous Code: FP-28DV)

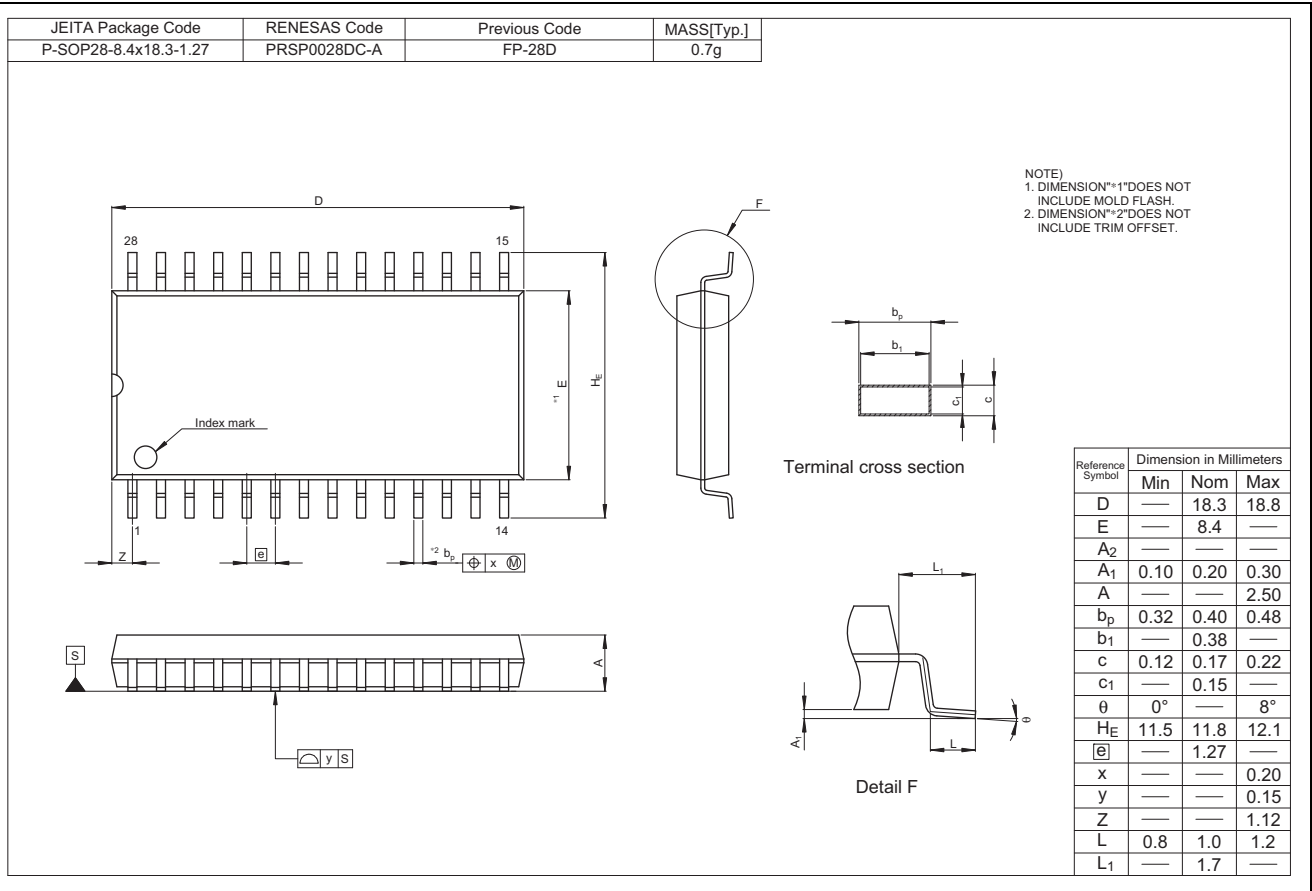

Package Dimensions (cont)

R1EV58064BTCN Series

R1EV58064BTCR Series (PTSA0028ZB-A / Previous Code: TFP-28DBV)

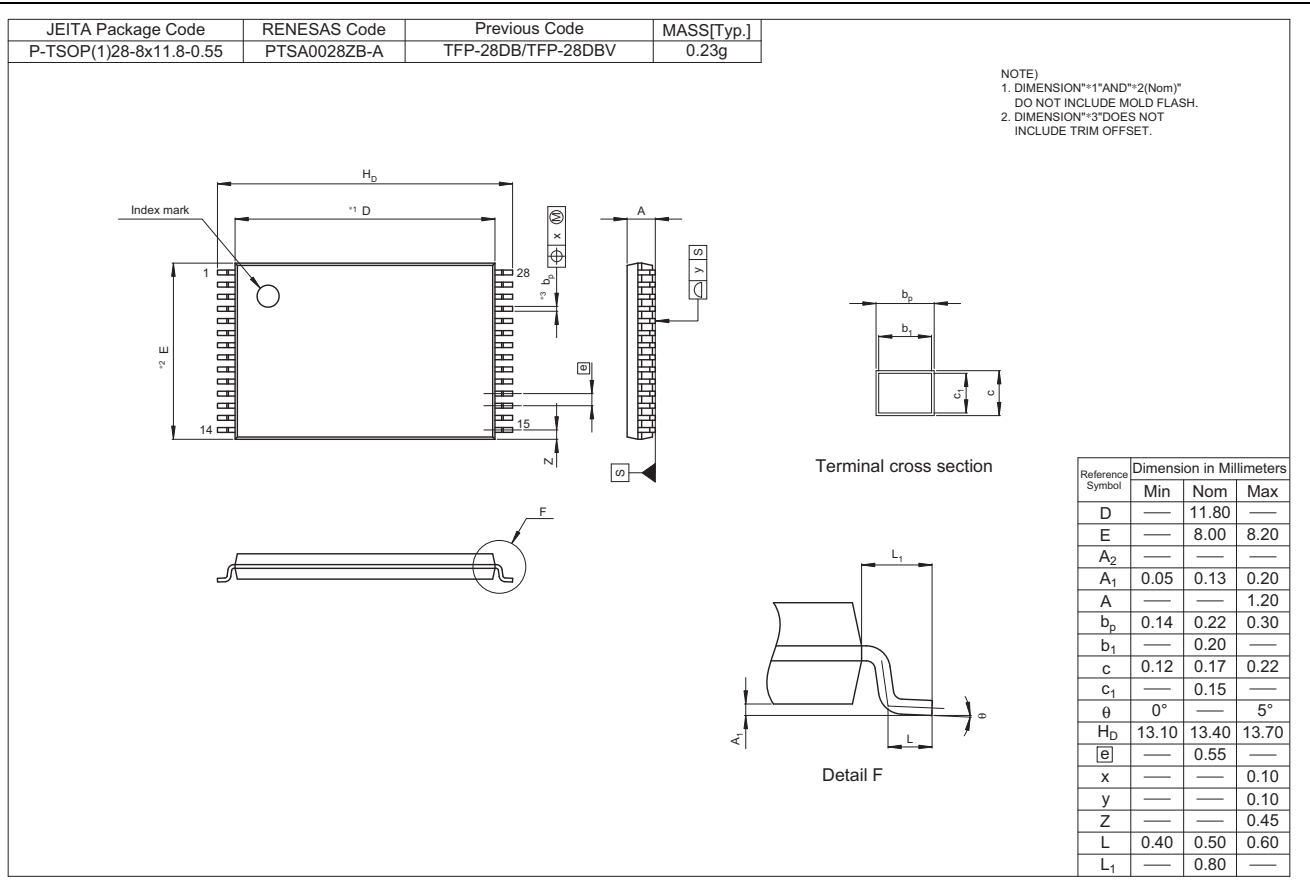

## Revision History

## R1EV58064BxxN Series/R1EV58064BxxR Series Data Sheet

Rev.	Date	Description	
		Page	Summary
0.01	Oct 17, 2013	—	Initial issue
0.02	Oct 18, 2013	1	Features: Deletion of (only the R1EV58064BxxR series) for Ready/ $\overline{\text{Busy}}$ .
		20	Orderable part Number Guide: Deletion of A and C for access time.
0.03	Nov 12, 2013	2	Ordering Information: Addition Orderable Part Name "R1EV58064BSCNBI#S0", "R1EV58064BSCRBI#S0"
1.00	Jun 09, 2014	—	Delete preliminary
2.00	May 12, 2016	4	DC Operating Conditions: Addition of Note 6.
		6	AC Characteristics: Addition of Max. 30us for $\overline{\text{WE}}$ pulse width (tWP) AC Characteristics: Addition of Max. 30us for $\overline{\text{CE}}$ pulse width (tCW)
		7	AC Characteristics: Addition of Max. 30us for $\overline{\text{WE}}$ pulse width (tWP) AC Characteristics: Addition of Max. 30us for $\overline{\text{CE}}$ pulse width (tCW)
2.01	Apr. 01,2020	2	Revised ordering Information
		Last page	Updated the Notice to the latest version



## Notice

1. Descriptions of circuits, software and other related information in this document are provided only to illustrate the operation of semiconductor products and application examples. You are fully responsible for the incorporation or any other use of the circuits, software, and information in the design of your product or system. Renesas Electronics disclaims any and all liability for any losses and damages incurred by you or third parties arising from the use of these circuits, software, or information.
  2. Renesas Electronics hereby expressly disclaims any warranties against and liability for infringement or any other claims involving patents, copyrights, or other intellectual property rights of third parties, by or arising from the use of Renesas Electronics products or technical information described in this document, including but not limited to, the product data, drawings, charts, programs, algorithms, and application examples.
  3. No license, express, implied or otherwise, is granted hereby under any patents, copyrights or other intellectual property rights of Renesas Electronics or others.
  4. You shall not alter, modify, copy, or reverse engineer any Renesas Electronics product, whether in whole or in part. Renesas Electronics disclaims any and all liability for any losses or damages incurred by you or third parties arising from such alteration, modification, copying or reverse engineering.
  5. Renesas Electronics products are classified according to the following two quality grades: "Standard" and "High Quality". The intended applications for each Renesas Electronics product depends on the product's quality grade, as indicated below.
    - "Standard": Computers; office equipment; communications equipment; test and measurement equipment; audio and visual equipment; home electronic appliances; machine tools; personal electronic equipment; industrial robots; etc.
    - "High Quality": Transportation equipment (automobiles, trains, ships, etc.); traffic control (traffic lights); large-scale communication equipment; key financial terminal systems; safety control equipment; etc.
- Unless expressly designated as a high reliability product or a product for harsh environments in a Renesas Electronics data sheet or other Renesas Electronics document, Renesas Electronics products are not intended or authorized for use in products or systems that may pose a direct threat to human life or bodily injury (artificial life support devices or systems; surgical implantations; etc.), or may cause serious property damage (space system; undersea repeaters; nuclear power control systems; aircraft control systems; key plant systems; military equipment; etc.). Renesas Electronics disclaims any and all liability for any damages or losses incurred by you or any third parties arising from the use of any Renesas Electronics product that is inconsistent with any Renesas Electronics data sheet, user's manual or other Renesas Electronics document.
6. When using Renesas Electronics products, refer to the latest product information (data sheets, user's manuals, application notes, "General Notes for Handling and Using Semiconductor Devices" in the reliability handbook, etc.), and ensure that usage conditions are within the ranges specified by Renesas Electronics with respect to maximum ratings, operating power supply voltage range, heat dissipation characteristics, installation, etc. Renesas Electronics disclaims any and all liability for any malfunctions, failure or accident arising out of the use of Renesas Electronics products outside of such specified ranges.
  7. Although Renesas Electronics endeavors to improve the quality and reliability of Renesas Electronics products, semiconductor products have specific characteristics, such as the occurrence of failure at a certain rate and malfunctions under certain use conditions. Unless designated as a high reliability product or a product for harsh environments in a Renesas Electronics data sheet or other Renesas Electronics document, Renesas Electronics products are not subject to radiation resistance design. You are responsible for implementing safety measures to guard against the possibility of bodily injury, injury or damage caused by fire, and/or danger to the public in the event of a failure or malfunction of Renesas Electronics products, such as safety design for hardware and software, including but not limited to redundancy, fire control and malfunction prevention, appropriate treatment for aging degradation or any other appropriate measures. Because the evaluation of microcomputer software alone is very difficult and impractical, you are responsible for evaluating the safety of the final products or systems manufactured by you.
  8. Please contact a Renesas Electronics sales office for details as to environmental matters such as the environmental compatibility of each Renesas Electronics product. You are responsible for carefully and sufficiently investigating applicable laws and regulations that regulate the inclusion or use of controlled substances, including without limitation, the EU RoHS Directive, and using Renesas Electronics products in compliance with all these applicable laws and regulations. Renesas Electronics disclaims any and all liability for damages or losses occurring as a result of your noncompliance with applicable laws and regulations.
  9. Renesas Electronics products and technologies shall not be used for or incorporated into any products or systems whose manufacture, use, or sale is prohibited under any applicable domestic or foreign laws or regulations. You shall comply with any applicable export control laws and regulations promulgated and administered by the governments of any countries asserting jurisdiction over the parties or transactions.
  10. It is the responsibility of the buyer or distributor of Renesas Electronics products, or any other party who distributes, disposes of, or otherwise sells or transfers the product to a third party, to notify such third party in advance of the contents and conditions set forth in this document.
  11. This document shall not be reprinted, reproduced or duplicated in any form, in whole or in part, without prior written consent of Renesas Electronics.
  12. Please contact a Renesas Electronics sales office if you have any questions regarding the information contained in this document or Renesas Electronics products.

(Note1) "Renesas Electronics" as used in this document means Renesas Electronics Corporation and also includes its directly or indirectly controlled subsidiaries.

(Note2) "Renesas Electronics product(s)" means any product developed or manufactured by or for Renesas Electronics.

(Rev.4.0-1 November 2017)

## Corporate Headquarters

TOYOSU FORESIA, 3-2-24 Toyosu,  
Koto-ku, Tokyo 135-0061, Japan  
[www.renesas.com](http://www.renesas.com)

## Contact Information

For further information on a product, technology, the most up-to-date version of a document, or your nearest sales office, please visit:  
[www.renesas.com/contact/](http://www.renesas.com/contact/)

## Trademarks

Renesas and the Renesas logo are trademarks of Renesas Electronics Corporation. All trademarks and registered trademarks are the property of their respective owners.