

PRODUCT DISCONTINUANCE NOTICE - LAST TIME BUY EXPIRES ON (11/18/13)

DATA SHEET

The MC100ES6535 is a low skew, high performance 3.3 V 1-to-4 LVCMOS to LVPECL fanout buffer. The ES6535 has two selectable inputs that allow LVCMOS or LVTTTL input levels which translate to LVPECL outputs. The clock enable is internally synchronized to eliminate runt pulses on the outputs during asynchronous assertion/deassertion of the clock enable pin. The ES6535 is ideal for high performance clock distribution applications.

Features

- 4 differential LVPECL outputs
- 2 selectable LVCMOS/LVTTTL inputs
- 1 GHz maximum output frequency
- Translates LVCMOS/LVTTTL levels to LVPECL levels
- 30 ps maximum output skew
- 190 ps part-to-part skew
- 3.3 V operating range
- 20-lead TSSOP package
- Ambient temperature range -40°C to +85°C
- 20-lead Pb-free package available
- **Use replacement part: ICS8535I-01**

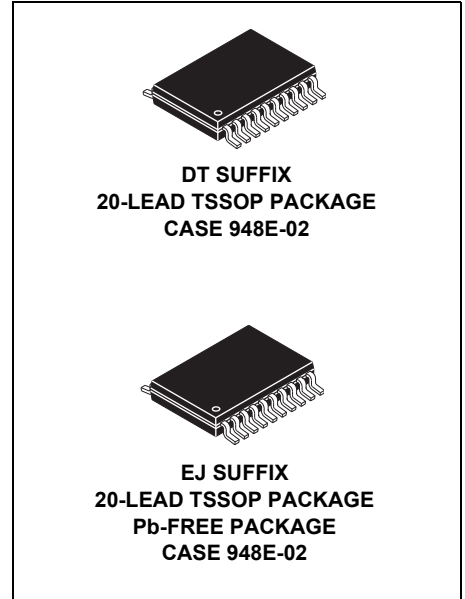

ORDERING INFORMATION	
Device	Package
MC100ES6535DT	TSSOP-20
MC100ES6535DTR2	TSSOP-20
MC100ES6535EJ	TSSOP-20 (Pb-Free)
MC100ES6535EJR2	TSSOP-20 (Pb-Free)

Table 1. Pin Description

Number	Name	Type		Description
1	V _{EE}	Power		Negative supply pin
2	CLK_EN	Input	Pullup ⁽¹⁾	Synchronizing clock enable. When HIGH, clock outputs follow clock input. When LOW, Q outputs are forced low, \bar{Q} outputs are forced high. LVCMOS/LVTTL interface levels
3	CLK_SEL	Input	Pulldown ⁽¹⁾	Clock select input. When HIGH, selects CLK1 input. When LOW, selects CLK0 input. LVCMOS/LVTTL interface levels
4	CLK0	Input	Pulldown ⁽¹⁾	LVCMOS/LVTTL clock input
6	CLK1	Input	Pulldown ⁽¹⁾	LVCMOS/LVTTL clock input
5, 7, 8, 9	NC	Unused		No connect
10, 13, 18	V _{CC}	Power		Positive supply pin
11, 12	Q3, \bar{Q} 3	Output		LVPECL differential output pair
14, 15	Q2, \bar{Q} 2	Output		LVPECL differential output pair
16, 17	Q1, \bar{Q} 1	Output		LVPECL differential output pair
19, 20	Q0, \bar{Q} 0	Output		LVPECL differential output pair

1. Pullup and Pulldown refer to internal input resistors.

Table 2. Control Input Function Table⁽¹⁾

Inputs			Outputs	
CLK_EN	CLK_SEL	Selected Source	Q0:Q3	\bar{Q} 0: \bar{Q} 3
0	0	CLK0	Disabled; LOW	Disabled; HIGH
0	1	CLK1	Disabled; LOW	Disabled; HIGH
1	0	CLK0	Enabled	Enabled
1	1	CLK1	Enabled	Enabled

1. After CLK_EN switches, the clock outputs are disabled or enabled following a rising and falling input clock edge. In the active mode, the state of the outputs are a function of the CLK0 and CLK1 inputs as described in .

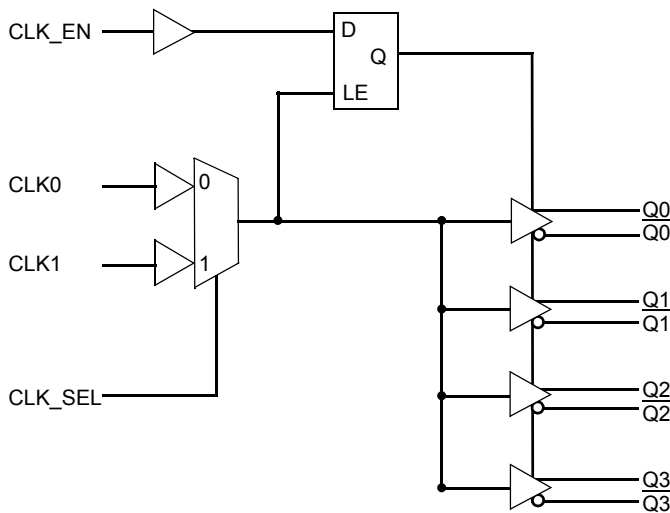

Figure 1. Logic Diagram

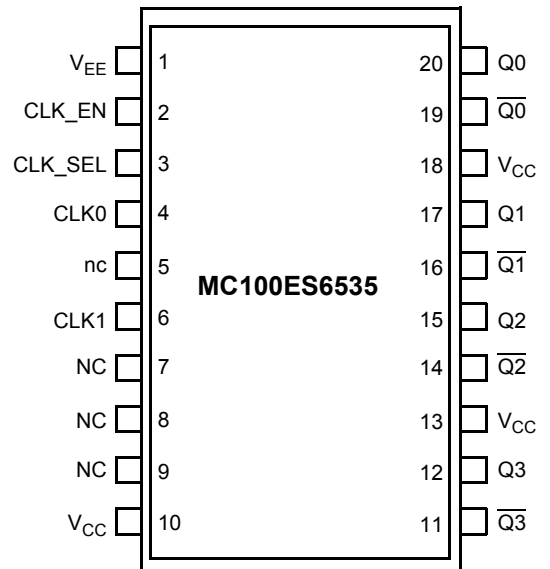

Figure 2. 20-Lead Pinout (Top View)

. Clock Input Function Table

Inputs	Outputs	
CLK0 or CLK1	Q0:Q3	Q0:Q3
0	LOW	HIGH
1	HIGH	LOW

Table 3. General Specifications

Characteristics	Value
Internal Input Pulldown Resistor	75 k Ω
Internal Input Pullup Resistor	75 k Ω
ESD Protection	Human Body Model Machine Model 4000 V 200 V
θ_{JA} Thermal Resistance (Junction-to-Ambient)	0 LFPM, 20 TSSOP 500 LFPM, 20 TSSOP 140°C/W 100°C/W

Meets or exceeds JEDEC Spec EIA/JESD78 IC Latchup Test

Table 4. Absolute Maximum Ratings⁽¹⁾

Symbol	Rating	Conditions	Rating	Units
V_{SUPPLY}	Power Supply Voltage	Difference between V_{CC} & V_{EE}	3.9	V
V_{IN}	Input Voltage	$V_{CC} - V_{EE} \leq 3.6$ V	$V_{CC} + 0.3$ $V_{EE} - 0.3$	V V
I_{out}	Output Current	Continuous Surge	50 100	mA mA
T_A	Operating Temperature Range		-40 to +85	°C
T_{store}	Storage Temperature Range		-65 to +150	°C

1. Absolute maximum continuous ratings are those maximum values beyond which damage to the device may occur. Exposure to these conditions or conditions beyond those indicated may adversely affect device reliability. Functional operation at absolute-maximum-rated conditions is not implied.

Table 5. DC Characteristics ($V_{CC} = 3.135$ V to 3.8 V; $V_{EE} = 0$ V)

Symbol	Characteristic	-40°C			0°C to 85°C			Unit
		Min	Typ	Max	Min	Typ	Max	
I_{EE}	Power Supply Current			35			45	mA
$V_{OH}^{(1)}$	Output HIGH Voltage	$V_{CC} - 1150$	$V_{CC} - 1020$	$V_{CC} - 800$	$V_{CC} - 1200$	$V_{CC} - 970$	$V_{CC} - 750$	mV
V_{OL}	Output LOW Voltage	$V_{CC} - 1950$	$V_{CC} - 1620$	$V_{CC} - 1250$	$V_{CC} - 2000$	$V_{CC} - 1680$	$V_{CC} - 1300$	mV

1. Outputs are terminated through a 50 Ω resistor to $V_{CC} - 2$ volts.

Table 6. LVTTTL / LVCMOS Input DC Characteristics ($V_{CC} = 3.135$ V to 3.8 V)

Symbol	Characteristic	Condition	-40°C			0°C to 85°C			Unit
			Min	Typ	Max	Min	Typ	Max	
I_{IN}	Input Current	$V_{IN} = V_{CC}$			± 150			± 150	μ A
V_{IK}	Input Clamp Voltage	$I_{IN} = -18$ mA			-1.2			-1.2	V
V_{IH}	Input HIGH Voltage		2.0		$V_{CC} + 0.3$	2.0		$V_{CC} + 0.3$	V
V_{IL}	Input LOW Voltage				0.8			0.8	V

Table 7. AC Characteristics ($V_{CC} = 3.135\text{ V to }3.8\text{ V}$, $V_{EE} = 0\text{ V}$)

Symbol	Characteristic	-40°C			25°C			85°C			Unit
		Min	Typ	Max	Min	Typ	Max	Min	Typ	Max	
f_{max}	Maximum Toggle Frequency			1			1			1	GHz
t_{PD}	Propagation Delay to Output Differential	150	350	500	175	360	550	200	380	600	ps
t_{SKEW}	Skew		20	30		20	30		20	30	ps
	Output-to-Output			190			190			190	ps
	Part-to-Part										ps
t_{JITTER}	Cycle-to-Cycle Jitter RMS (1σ)			1			1			1	ps
V_{outPP}	Output Peak-to-Peak Voltage	350	750		350	750		350	750		mV
t_r/t_f	Output Rise/Fall Time (20%–80% @ 50 MHz)	50		400	50		400	50		400	ps

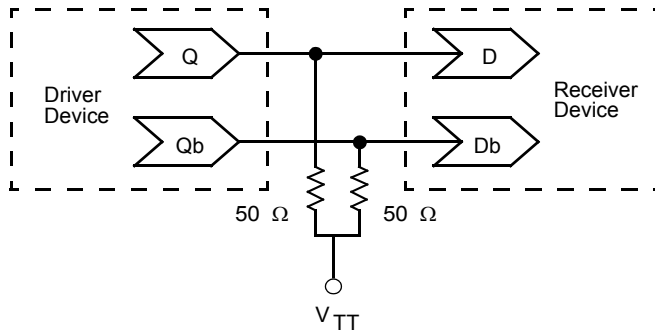
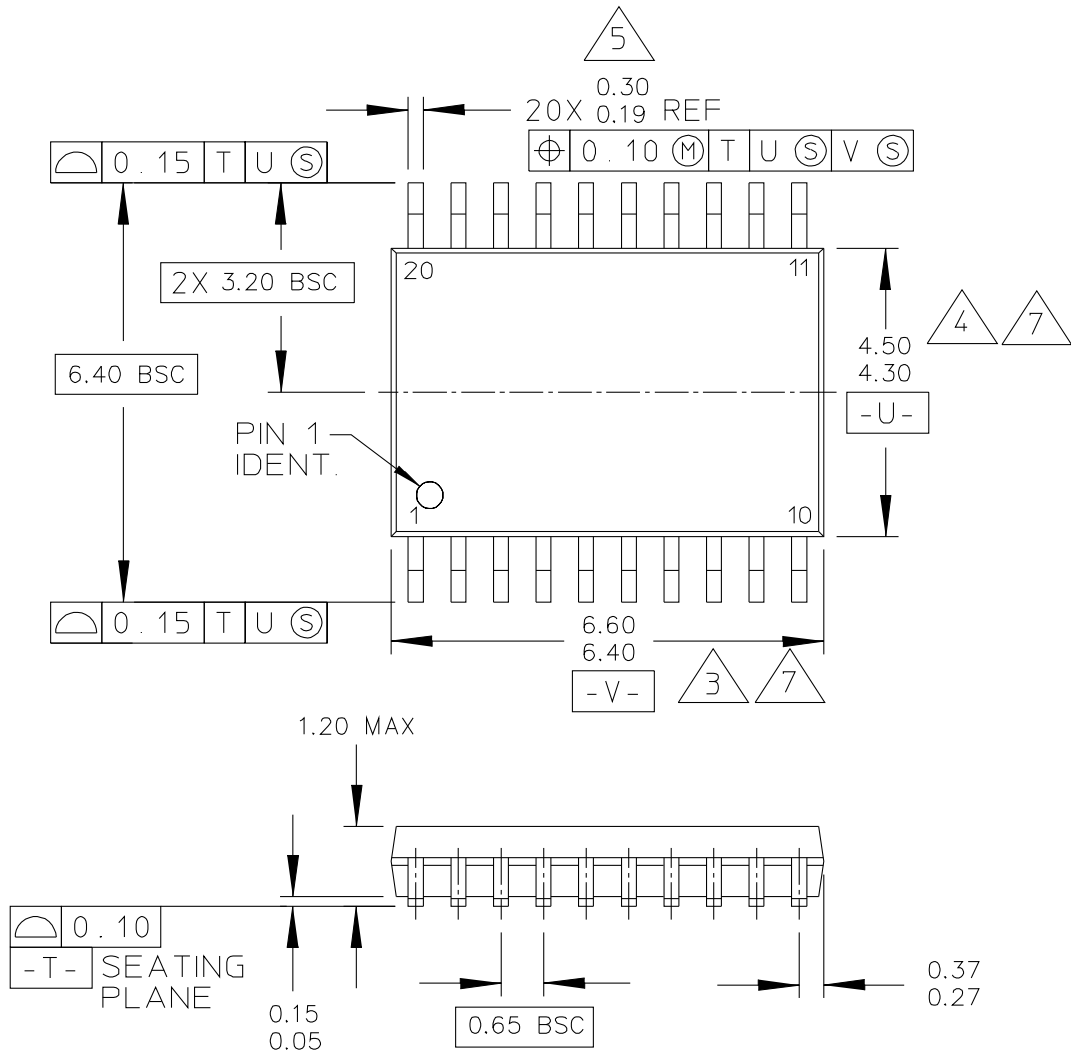

Figure 3. Typical Termination for Output Driver and Device Evaluation

PACKAGE DIMENSIONS



© FREESCALE SEMICONDUCTOR, INC. ALL RIGHTS RESERVED.	MECHANICAL OUTLINE	PRINT VERSION NOT TO SCALE	
TITLE: 20 LD TSSOP, PITCH 0.65MM	DOCUMENT NO: 98ASH70169A		REV: C
	CASE NUMBER: 948E-02		25 MAY 2005
	STANDARD: JEDEC		

**CASE 948E-02
ISSUE C
20-LEAD TSSOP PACKAGE**

PACKAGE DIMENSIONS

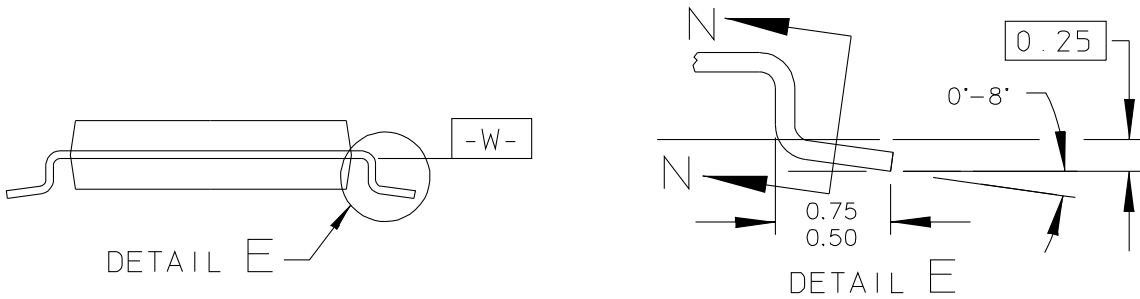
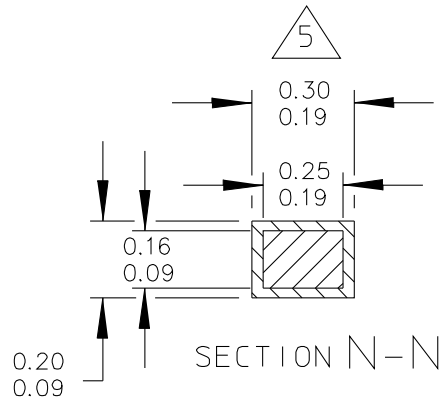

© FREESCALE SEMICONDUCTOR, INC. ALL RIGHTS RESERVED.	MECHANICAL OUTLINE	PRINT VERSION NOT TO SCALE	
TITLE: 20 LD TSSOP, PITCH 0.65MM	DOCUMENT NO: 98ASH70169A	REV: C	
	CASE NUMBER: 948E-02	25 MAY 2005	
	STANDARD: JEDEC		

**CASE 948E-02
ISSUE C
20-LEAD TSSOP PACKAGE**

PACKAGE DIMENSIONS

NOTES:

1. CONTROLLING DIMENSION: MILLIMETER
2. DIMENSIONS AND TOLERANCES PER ANSI Y14.5M-1982.

3. DIMENSION DOES NOT INCLUDE MOLD FLASH, PROTRUSIONS OR GATE BURRS. MOLD FLASH OR GATE BURRS SHALL NOT EXCEED 0.15 PER SIDE.

4. DIMENSION DOES NOT INCLUDE INTERLEAD FLASH OR PROTRUSION. INTERLEAD FLASH OR PROTRUSION SHALL NOT EXCEED 0.25 PER SIDE.

5. DIMENSION DOES NOT INCLUDE DAMBAR PROTRUSION. ALLOWABLE DAMBAR PROTRUSION SHALL BE 0.08 TOTAL IN EXCESS OF THE DIMENSION AT MAXIMUM MATERIAL CONDITION.

6. TERMINAL NUMBERS ARE SHOWN FOR REFERENCE ONLY.

7. DIMENSIONS ARE TO BE DETERMINED AT DATUM PLANE -W-.

© FREESCALE SEMICONDUCTOR, INC. ALL RIGHTS RESERVED.	MECHANICAL OUTLINE	PRINT VERSION NOT TO SCALE
TITLE: 20 LD TSSOP, PITCH 0.65MM	DOCUMENT NO: 98ASH70169A	REV: C
	CASE NUMBER: 948E-02	25 MAY 2005
	STANDARD: JEDEC	

**CASE 948E-02
ISSUE C
20-LEAD TSSOP PACKAGE**

Revision History Sheet

Rev	Table	Page	Description of Change	Date
4		1	Product Discontinuance Notice - Last Time Buy Expires on (11/18/13) Use replacement part: ICS8535I-01	12/14/2012

IMPORTANT NOTICE AND DISCLAIMER

RENESAS ELECTRONICS CORPORATION AND ITS SUBSIDIARIES (“RENESAS”) PROVIDES TECHNICAL SPECIFICATIONS AND RELIABILITY DATA (INCLUDING DATASHEETS), DESIGN RESOURCES (INCLUDING REFERENCE DESIGNS), APPLICATION OR OTHER DESIGN ADVICE, WEB TOOLS, SAFETY INFORMATION, AND OTHER RESOURCES “AS IS” AND WITH ALL FAULTS, AND DISCLAIMS ALL WARRANTIES, EXPRESS OR IMPLIED, INCLUDING, WITHOUT LIMITATION, ANY IMPLIED WARRANTIES OF MERCHANTABILITY, FITNESS FOR A PARTICULAR PURPOSE, OR NON-INFRINGEMENT OF THIRD-PARTY INTELLECTUAL PROPERTY RIGHTS.

These resources are intended for developers who are designing with Renesas products. You are solely responsible for (1) selecting the appropriate products for your application, (2) designing, validating, and testing your application, and (3) ensuring your application meets applicable standards, and any other safety, security, or other requirements. These resources are subject to change without notice. Renesas grants you permission to use these resources only to develop an application that uses Renesas products. Other reproduction or use of these resources is strictly prohibited. No license is granted to any other Renesas intellectual property or to any third-party intellectual property. Renesas disclaims responsibility for, and you will fully indemnify Renesas and its representatives against, any claims, damages, costs, losses, or liabilities arising from your use of these resources. Renesas' products are provided only subject to Renesas' Terms and Conditions of Sale or other applicable terms agreed to in writing. No use of any Renesas resources expands or otherwise alters any applicable warranties or warranty disclaimers for these products.

(Disclaimer Rev.1.01)

Corporate Headquarters

TOYOSU FORESIA, 3-2-24 Toyosu,
Koto-ku, Tokyo 135-0061, Japan
www.renesas.com

Trademarks

Renesas and the Renesas logo are trademarks of Renesas Electronics Corporation. All trademarks and registered trademarks are the property of their respective owners.

Contact Information

For further information on a product, technology, the most up-to-date version of a document, or your nearest sales office, please visit www.renesas.com/contact-us/.