

To our customers,

Old Company Name in Catalogs and Other Documents

On April 1st, 2010, NEC Electronics Corporation merged with Renesas Technology Corporation, and Renesas Electronics Corporation took over all the business of both companies. Therefore, although the old company name remains in this document, it is a valid Renesas Electronics document. We appreciate your understanding.

Renesas Electronics website: <http://www.renesas.com>

April 1st, 2010
Renesas Electronics Corporation

Issued by: Renesas Electronics Corporation (<http://www.renesas.com>)

Send any inquiries to <http://www.renesas.com/inquiry>.

Notice

1. All information included in this document is current as of the date this document is issued. Such information, however, is subject to change without any prior notice. Before purchasing or using any Renesas Electronics products listed herein, please confirm the latest product information with a Renesas Electronics sales office. Also, please pay regular and careful attention to additional and different information to be disclosed by Renesas Electronics such as that disclosed through our website.
2. Renesas Electronics does not assume any liability for infringement of patents, copyrights, or other intellectual property rights of third parties by or arising from the use of Renesas Electronics products or technical information described in this document. No license, express, implied or otherwise, is granted hereby under any patents, copyrights or other intellectual property rights of Renesas Electronics or others.
3. You should not alter, modify, copy, or otherwise misappropriate any Renesas Electronics product, whether in whole or in part.
4. Descriptions of circuits, software and other related information in this document are provided only to illustrate the operation of semiconductor products and application examples. You are fully responsible for the incorporation of these circuits, software, and information in the design of your equipment. Renesas Electronics assumes no responsibility for any losses incurred by you or third parties arising from the use of these circuits, software, or information.
5. When exporting the products or technology described in this document, you should comply with the applicable export control laws and regulations and follow the procedures required by such laws and regulations. You should not use Renesas Electronics products or the technology described in this document for any purpose relating to military applications or use by the military, including but not limited to the development of weapons of mass destruction. Renesas Electronics products and technology may not be used for or incorporated into any products or systems whose manufacture, use, or sale is prohibited under any applicable domestic or foreign laws or regulations.
6. Renesas Electronics has used reasonable care in preparing the information included in this document, but Renesas Electronics does not warrant that such information is error free. Renesas Electronics assumes no liability whatsoever for any damages incurred by you resulting from errors in or omissions from the information included herein.
7. Renesas Electronics products are classified according to the following three quality grades: “Standard”, “High Quality”, and “Specific”. The recommended applications for each Renesas Electronics product depends on the product’s quality grade, as indicated below. You must check the quality grade of each Renesas Electronics product before using it in a particular application. You may not use any Renesas Electronics product for any application categorized as “Specific” without the prior written consent of Renesas Electronics. Further, you may not use any Renesas Electronics product for any application for which it is not intended without the prior written consent of Renesas Electronics. Renesas Electronics shall not be in any way liable for any damages or losses incurred by you or third parties arising from the use of any Renesas Electronics product for an application categorized as “Specific” or for which the product is not intended where you have failed to obtain the prior written consent of Renesas Electronics. The quality grade of each Renesas Electronics product is “Standard” unless otherwise expressly specified in a Renesas Electronics data sheets or data books, etc.
 - “Standard”: Computers; office equipment; communications equipment; test and measurement equipment; audio and visual equipment; home electronic appliances; machine tools; personal electronic equipment; and industrial robots.
 - “High Quality”: Transportation equipment (automobiles, trains, ships, etc.); traffic control systems; anti-disaster systems; anti-crime systems; safety equipment; and medical equipment not specifically designed for life support.
 - “Specific”: Aircraft; aerospace equipment; submersible repeaters; nuclear reactor control systems; medical equipment or systems for life support (e.g. artificial life support devices or systems), surgical implantations, or healthcare intervention (e.g. excision, etc.), and any other applications or purposes that pose a direct threat to human life.
8. You should use the Renesas Electronics products described in this document within the range specified by Renesas Electronics, especially with respect to the maximum rating, operating supply voltage range, movement power voltage range, heat radiation characteristics, installation and other product characteristics. Renesas Electronics shall have no liability for malfunctions or damages arising out of the use of Renesas Electronics products beyond such specified ranges.
9. Although Renesas Electronics endeavors to improve the quality and reliability of its products, semiconductor products have specific characteristics such as the occurrence of failure at a certain rate and malfunctions under certain use conditions. Further, Renesas Electronics products are not subject to radiation resistance design. Please be sure to implement safety measures to guard them against the possibility of physical injury, and injury or damage caused by fire in the event of the failure of a Renesas Electronics product, such as safety design for hardware and software including but not limited to redundancy, fire control and malfunction prevention, appropriate treatment for aging degradation or any other appropriate measures. Because the evaluation of microcomputer software alone is very difficult, please evaluate the safety of the final products or system manufactured by you.
10. Please contact a Renesas Electronics sales office for details as to environmental matters such as the environmental compatibility of each Renesas Electronics product. Please use Renesas Electronics products in compliance with all applicable laws and regulations that regulate the inclusion or use of controlled substances, including without limitation, the EU RoHS Directive. Renesas Electronics assumes no liability for damages or losses occurring as a result of your noncompliance with applicable laws and regulations.
11. This document may not be reproduced or duplicated, in any form, in whole or in part, without prior written consent of Renesas Electronics.
12. Please contact a Renesas Electronics sales office if you have any questions regarding the information contained in this document or Renesas Electronics products, or if you have any other inquiries.

(Note 1) “Renesas Electronics” as used in this document means Renesas Electronics Corporation and also includes its majority-owned subsidiaries.

(Note 2) “Renesas Electronics product(s)” means any product developed or manufactured by or for Renesas Electronics.

To all our customers

Regarding the change of names mentioned in the document, such as Mitsubishi Electric and Mitsubishi XX, to Renesas Technology Corp.

The semiconductor operations of Hitachi and Mitsubishi Electric were transferred to Renesas Technology Corporation on April 1st 2003. These operations include microcomputer, logic, analog and discrete devices, and memory chips other than DRAMs (flash memory, SRAMs etc.) Accordingly, although Mitsubishi Electric, Mitsubishi Electric Corporation, Mitsubishi Semiconductors, and other Mitsubishi brand names are mentioned in the document, these names have in fact all been changed to Renesas Technology Corp. Thank you for your understanding. Except for our corporate trademark, logo and corporate statement, no changes whatsoever have been made to the contents of the document, and these changes do not constitute any alteration to the contents of the document itself.

Note : Mitsubishi Electric will continue the business operations of high frequency & optical devices and power devices.

Renesas Technology Corp.
Customer Support Dept.
April 1, 2003

MITSUBISHI MICROCOMPUTERS M37220M3-XXXSP

SINGLE-CHIP 8-BIT CMOS MICROCOMPUTER for VOLTAGE SYNTHESIZER
with ON-SCREEN DISPLAY CONTROLLER

DESCRIPTION

The M37220M3-XXXSP is a single-chip microcomputer designed with CMOS silicon gate technology. It is housed in a 42-pin shrink plastic molded DIP.

In addition to their simple instruction sets, the ROM, RAM and I/O addresses are placed on the same memory map to enable easy programming.

The M37220M3-XXXSP has a PWM output function and a OSD display function, so it is useful for a channel selection system for TV.

FEATURES

- Number of basic instructions 71
- Memory size
 - ROM 12 K bytes
 - RAM 256 bytes
 - ROM for display 4 K bytes
 - RAM for display 80 bytes
- The minimum instruction execution time 0.5μs (at 8 MHz oscillation frequency)
- Power source voltage 5 V ± 10 %
- Power dissipation 165 mW (at 8 MHz oscillation frequency, V_{CC}=5.5V, at CRT display)
- Subroutine nesting 96 levels (maximum)
- Interrupts 13 types, 13 vectors
- 8-bit timers 4
- Programmable I/O ports (Ports P0, P1, P2, P30-P32) 27
- Input ports (Ports P33, P34) 2
- Output ports (Ports P52-P55) 4
- 12 V withstand ports 6
- LED drive ports 4
- Serial I/O 8-bit X 1 channel
- A-D comparator (6-bit resolution) 6 channels
- D-A converter (6-bit resolution) 2
- PWM output circuit 14-bit X 1, 8-bit X 6

PIN CONFIGURATION (TOP VIEW)

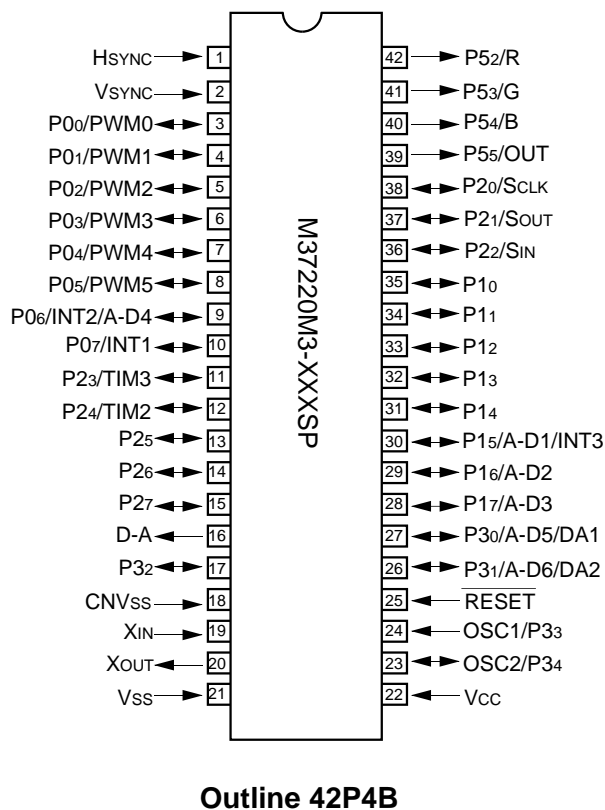

• CRT display function

- Number of display characters 24 characters X 2 lines (16 lines maximum)
- Kinds of characters 128 kinds
- Dot structure 12 X 16 dots
- Kinds of character sizes 3 kinds
- Kinds of character colors (It can be specified by the character) maximum 7 kinds (R, G, B)
- Kinds of raster colors (maximum 7 kinds)
- Display position
 - Horizontal 64 levels
 - Vertical 128 levels
- Bordering (horizontal and vertical)

APPLICATION

TV

M37220M3-XXXSP

SINGLE-CHIP 8-BIT CMOS MICROCOMPUTER for VOLTAGE SYNTHESIZER
with ON-SCREEN DISPLAY CONTROLLER

FUNCTIONAL BLOCK DIAGRAM of M37220M3-XXXSP

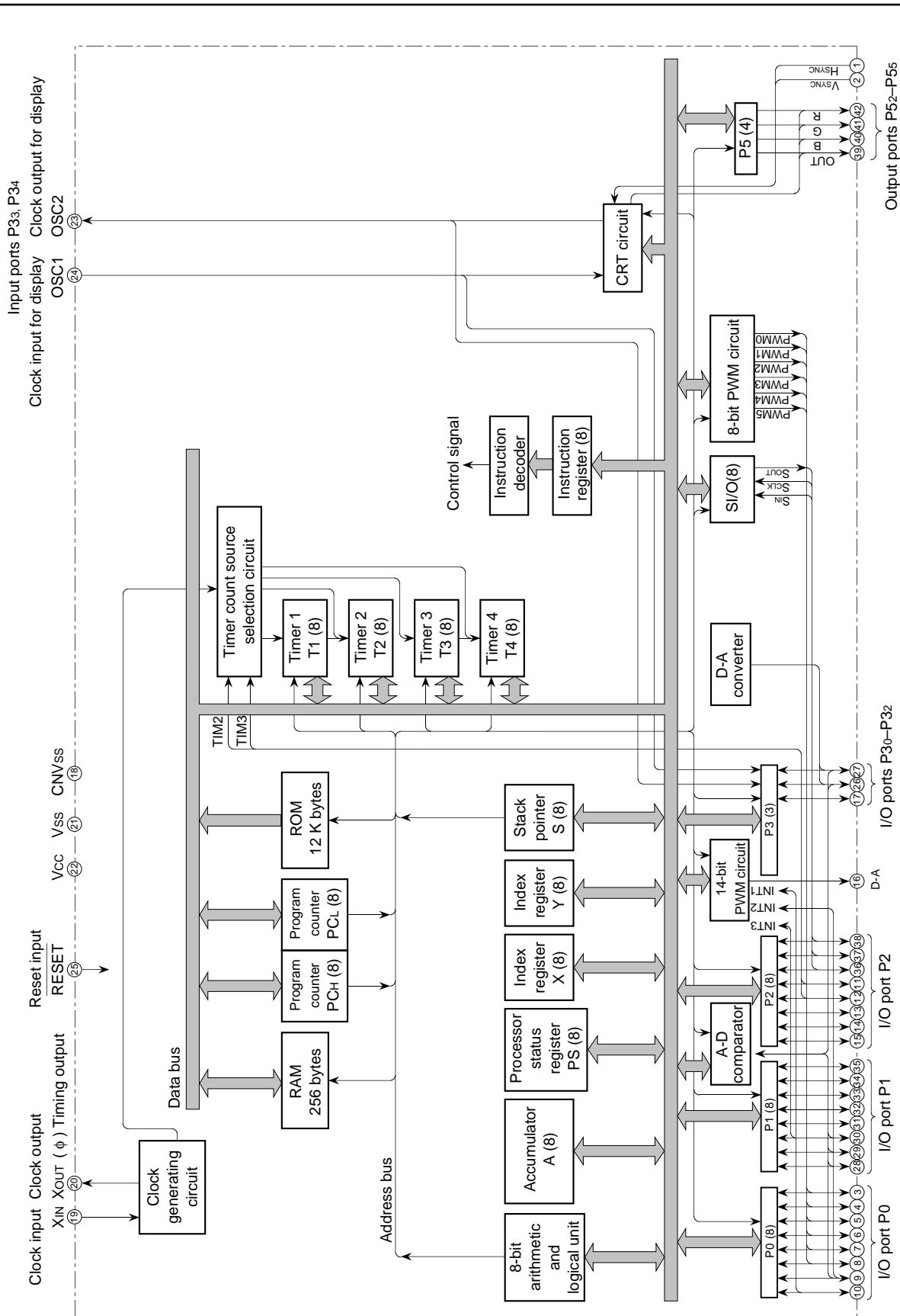

SINGLE-CHIP 8-BIT CMOS MICROCOMPUTER for VOLTAGE SYNTHESIZER
with ON-SCREEN DISPLAY CONTROLLER

FUNCTIONS

Parameter		Functions	
Number of basic instructions		71	
Instruction execution time		0.5 μs (the minimum instruction execution time, at 8 MHz oscillation frequency)	
Clock frequency		8 MHz (maximum)	
Memory size	ROM	12K bytes	
	RAM	256 bytes	
	CRT ROM	4K bytes	
	CRT RAM	80 bytes	
Input/Output ports	P0	I/O	8-bit X 1 (N-channel open-drain output structure, can be used as PWM output pins, INT input pins, A-D input pin)
	P10–P17	I/O	8-bit X 1 (CMOS input/output structure, can be used as A-D input pins, INT input pin)
	P20, P21	I/O	2-bit X 1 (CMOS input/output or N-channel open-drain output structure, can be used as serial output pins)
	P22–P27	I/O	6-bit X 1 (CMOS input/output structure, can be used as serial input pin, external clock input pins)
	P30, P31	I/O	2-bit X 1 (CMOS input/output or N-channel open-drain output structure, can be used as A-D input pins, D-A conversion output pins)
	P32	I/O	1-bit X 1 (N-channel open-drain output structure)
	P33, P34	Input	2-bit X 1 (can be used as CRT display clock I/O pins)
	P52–P55	Output	4-bit X 1 (CMOS output structure, can be used as CRT output pins)
Serial I/O		8-bit X 1	
A-D comparatpr		6 channels (6-bit resolution)	
D-A converter		2 (6-bit resolution)	
PWM output circuit		14-bit X 1, 8-bit X 6	
Timers		8-bit timer X 4	
Subroutine nesting		96 levels (maximum)	
Interrupt		External interrupt X 3, Internal timer interrupt X 4, Serial I/O interrupt X 1, CRT interrupt X 1, XIN/4096 interrupt X 1, VSYNC interrupt X 1, BRK interrupt X 1	
Clock generating circuit		2 built-in circuits (externally connected a ceramic resonator or a quartz-crystal oscillator)	
Power source voltage		5 V ± 10 %	
Power dissipation	CRT ON	165 mW typ. (at oscillation frequency f _{CPU} = 8 MHz, f _{CRT} = 8 MHz)	
	CRT OFF	110 mW typ. (at oscillation frequency f _{CPU} = 8 MHz)	
	In stop mode	1.65 mW (maximum)	
Operating temperature range		–10 °C to 70 °C	
Device structure		CMOS silicon gate process	
Package		42-pin shrink plastic molded DIP	
CRT display function	Number of display characters	20 characters X 2 lines (maximum 16 lines by software)	
	Dot structure	12 X 16 dots	
	Kinds of characters	128 kinds	
	Kinds of character sizes	3 kinds	
	Kinds of character colors	Maximum 7 kinds (R, G, B); can be specified by the character	
	Display position (horizontal, vertical)	64 levels (horizontal) X 128 levels (vertical)	

SINGLE-CHIP 8-BIT CMOS MICROCOMPUTER for VOLTAGE SYNTHESIZER
with ON-SCREEN DISPLAY CONTROLLER

PIN DESCRIPTION

Pin	Name	Input/ Output	Functions
Vcc, Vss	Power source		Apply voltage of $5\text{ V} \pm 10\%$ (typical) to Vcc, and 0 V to Vss.
CNVss	CNVss		This is connected to Vss.
RESET	Reset input	Input	To enter the reset state, the reset input pin must be kept at a "L" for 2 μs or more (under normal VCC conditions). If more time is needed for the quartz-crystal oscillator to stabilize, this "L" condition should be maintained for the required time.
XIN	Clock input	Input	This chip has an internal clock generating circuit. To control generating frequency, an external ceramic resonator or a quartz-crystal oscillator is connected between pins XIN and XOUT. If an external clock is used, the clock source should be connected to the XIN pin and the XOUT pin should be left open.
XOUT	Clock output	Output	
P00/PWM0– P05/PWM5, P06/INT2/ A-D4, P07/INT1	I/O port P0	I/O	Port P0 is an 8-bit I/O port with direction register allowing each I/O bit to be individually programmed as input or output. At reset, this port is set to input mode. The output structure is N-channel open-drain output. The note out of this Table gives a full of port P0 function.
	PWM output	Output	Pins P00–P05 are also used as PWM output pins PWM0–PWM5 respectively. The output structure is N-channel open-drain output.
	External interrupt input	Input	Pins P06, P07 are also used as external interrupt input pins INT2, INT1 respectively.
	Analog input	Input	Pins P06 is also used as an analog interrupt input pin A-D4.
P10–P14, P15/A-D1 INT3, P16/A-D2, P17/A-D3	I/O port P1	I/O	Port P1 is an 8-bit I/O port and has basically the same functions as port P0. The output structure is CMOS output.
	Analog input	Input	Pins P15–P17 are also used as an analog input pins A-D1 to A-D3.
	External interrupt input	Input	Pin P15 is also used as an external interrupt input pins INT3.
P20/SCLK, P21/SOUT, P22/SIN, P23/TIM3, P24/TIM2, P25–P27	I/O port P2	I/O	Port P2 is an 8-bit I/O port and has basically the same functions as port P0. The output structure is CMOS output.
	External clock input	Input	Pins P23, P24 is also used an external clock input pins TIM3, TIM2 respectively.
	Serial I/O data input/output	I/O	Pins P21, P22 are also used serial I/O data input/output pins SOUT, SIN respectively. The output structure is N-channel open-drain output.
	Serial I/O synchronizing clock input/output	I/O	Pin P20 is also used serial I/O synchronizing clock input/output pin SCLK. The output structure is N-channel open-drain output.
P30/A-D5/ DA1, P31/A-D6/ DA2, P32	I/O port P3	I/O	Ports P30–P32 are a 3-bit I/O port and have basically the same functions as port P0. Either CMOS output or N-channel open-drain output structure can be selected as the ports P30 and P31. The output structure of port P32 is N-channel open-drain output.
	Analog input	Input	Pins P30, P31 are also used as analog input pins A-D5, A-D6 respectively.
	D-A conversion output	Output	Pins P30, P31 are also used as D-A conversion output pins DA1, DA2 respectively.
P33/OSC1, P34/OSC2	Input port P3	Input	Ports P33, P34 are a 2-bit input port.
	Clock input for CRT display	Input	Pin P33 is also used as CRT display clock input pin OSC1.
	Clock output for CRT display	Output	Pin P34 is also used as CRT display clock output pin OSC2. The output structure is CMOS output.

SINGLE-CHIP 8-BIT CMOS MICROCOMPUTER for VOLTAGE SYNTHESIZER
with ON-SCREEN DISPLAY CONTROLLER

PIN DESCRIPTION (continued)

P52/R, P53/G, P54/B, P55/OUT	Output port P5 CRT output	Output Output	Ports P52–P55 are a 4-bit output port. The output structure is CMOS output. Pins P52–P55 are also used as CRT output pins R, G, B, OUT respectively. The output structure is CMOS output.
HSYNC	HSYNC input	Input	This is a horizontal synchronizing signal input for CRT display.
VSNC	VSNC input	Input	This is a vertical synchronizing signal input for CRT display.
D-A	DA output	Output	This is an output pin for 14-bit PWM.

Note : As shown in the memory map (Figure 3), port P0 is accessed as a memory at address 00C0₁₆ of zero page. Port P0 has the port P0 direction register (address 00C1₁₆ of zero page) which can be used to program each bit as an input (“0”) or an output (“1”). The pins programmed as “1” in the direction register are output pins. When pins are programmed as “0,” they are input pins. When pins are programmed as output pins, the output data are written into the port latch and then output. When data is read from the output pins, the output pin level is not read but the data of the port latch is read. This allows a previously-output value to be read correctly even if the output “L” voltage has risen, for example, because a light emitting diode was directly driven. The input pins are in the floating state, so the values of the pins can be read. When data is written into the input pin, it is written only into the port latch, while the pin remains in the floating state.

MEMORY

Special Function Register (SFR) Area

The special function register (SFR) area in the zero page contains control registers such as I/O ports and timers.

RAM

RAM is used for data storage and for stack area of subroutine calls and interrupts.

ROM

ROM is used for storing user programs as well as the interrupt vector area.

RAM for Display

RAM for display is used for specifying the character codes and colors to display.

ROM for Display

ROM for display is used for storing character data.

Interrupt Vector Area

The interrupt vector area contains reset and interrupt vectors.

Zero Page

The 256 bytes from addresses 0000₁₆ to 00FF₁₆ are called the zero page area. The internal RAM and the special function registers (SFR) are allocated to this area.

The zero page addressing mode can be used to specify memory and register addresses in the zero page area. Access to this area with only 2 bytes is possible in the zero page addressing mode.

Special Page

The 256 bytes from addresses FF00₁₆ to FFFF₁₆ are called the special page area. The special page addressing mode can be used to specify memory addresses in the special page area. Access to this area with only 2 bytes is possible in the special page addressing mode.

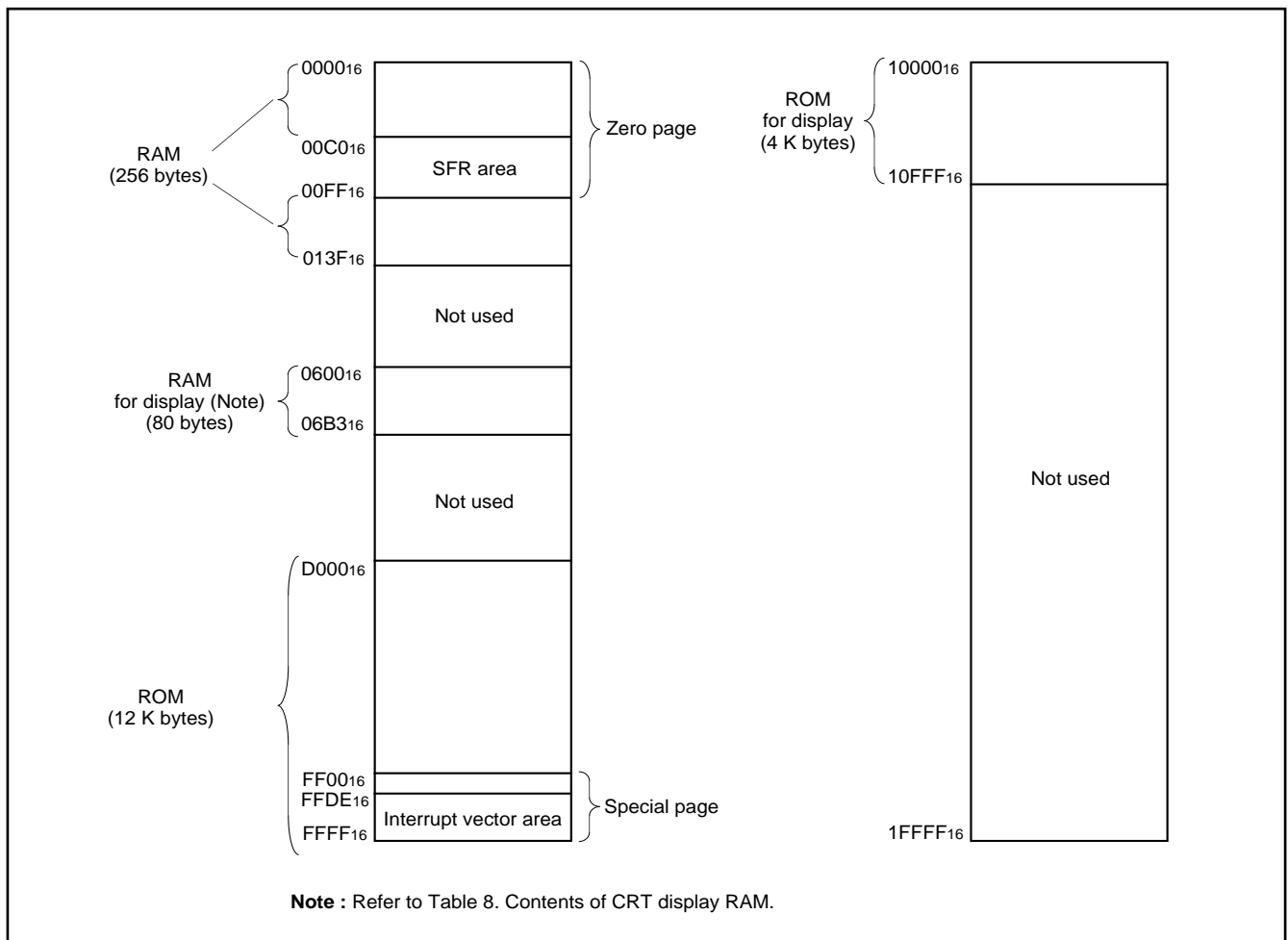

Fig. 2. Memory map







■SFR area (addresses C0₁₆ to DF₁₆)

- : Nothing is allocated
- : Fix this bit to "0" (do not write "1")
- 0 : "0" immediately after reset
- 1 : "1" immediately after reset
- ? : undefined immediately after reset

Address	Register	Bit allocation								State immediately after reset								
		b7							b0	b7							b0	
C0 ₁₆	Port P0 (P0)																	?
C1 ₁₆	Port P0 direction register (D0)																	00 ₁₆
C2 ₁₆	Port P1 (P1)																	?
C3 ₁₆	Port P1 direction register (D1)																	00 ₁₆
C4 ₁₆	Port P2 (P2)																	?
C5 ₁₆	Port P2 direction register (D2)																	00 ₁₆
C6 ₁₆	Port P3 (P3)									0	0	0	?	?	?	?	?	
C7 ₁₆	Port P3 direction register (D3)									0	0	0	0	0	0	0	0	
C8 ₁₆																		?
C9 ₁₆																		?
CA ₁₆	Port P5 (P5)									0	0	?	?	?	?	?	?	
CB ₁₆	Port P5 direction register (D5)									0	0	0	0	0	0	0	0	
CC ₁₆																		?
CD ₁₆	Port P3 output mode control register (P3S)																	00000000
CE ₁₆	DA-H register (DA-H)																	?
CF ₁₆	DA-L register (DA-L)									0	0	?	?	?	?	?	?	
D0 ₁₆	PWM0 register (PWM0)																	?
D1 ₁₆	PWM1 register (PWM1)																	?
D2 ₁₆	PWM2 register (PWM2)																	?
D3 ₁₆	PWM3 register (PWM3)																	?
D4 ₁₆	PWM4 register (PWM4)																	?
D5 ₁₆	PWM output control register 1 (PW)		PW7	PW6	PW5	PW4	PW3	PW2	PW1	PW0								00 ₁₆
D6 ₁₆	PWM output control register 2 (PN)										0	0	0	0	0	0	0	
D7 ₁₆																		?
D8 ₁₆																		?
D9 ₁₆																		?
DA ₁₆																		?
DB ₁₆																		?
DC ₁₆	Serial I/O mode register (SM)		SM6	SM5		SM3	SM2	SM1	SM0	0	0	0	0	0	0	0	0	
DD ₁₆	Serial I/O register (SIO)																	?
DE ₁₆	DA1 conversion register (DA1)			DA15	DA14	DA13	DA12	DA11	DA10	0	0	?	?	?	?	?	?	
DF ₁₆	DA2 conversion register (DA2)			DA25	DA24	DA23	DA22	DA21	DA20	0	0	?	?	?	?	?	?	

Fig. 3. Memory map of SFR (special function register) (1)

■SFR area (addresses E0₁₆ to FF₁₆)

-  : Nothing is allocated
-  : Fix this bit to "0" (do not write "1")
-  : Fix this bit to "1" (do not write "0")
-  : "0" immediately after reset
-  : "1" immediately after reset
-  : undefined immediately after reset



























Address	Register	Bit allocation								State immediately after reset							
		b7							b0	b7							b0
E0 ₁₆	Horizontal position register (HR)			HR5	HR4	HR3	HR2	HR1	HR0	0	0	0	0	0	0	0	0
E1 ₁₆	Vertical register 1 (CV1)		CV16	CV15	CV14	CV13	CV12	CV11	CV10	0	?	?	?	?	?	?	?
E2 ₁₆	Vertical register 2 (CV2)		CV26	CV25	CV24	CV23	CV22	CV21	CV20	0	?	?	?	?	?	?	?
E3 ₁₆										?							
E4 ₁₆	Character size register (CS)					CS21	CS20	CS11	CS10	0	0	0	0	?	?	?	?
E5 ₁₆	Border selection register (MD)						MD20		MD10	0	0	0	0	0	?	0	?
E6 ₁₆	Color register 0 (CO0)			CO05		CO03	CO02	CO01		0	0	0	0	0	0	0	0
E7 ₁₆	Color register 1 (CO1)			CO15		CO13	CO12	CO11		0	0	0	0	0	0	0	0
E8 ₁₆	Color register 2 (CO2)			CO25		CO23	CO22	CO21		0	0	0	0	0	0	0	0
E9 ₁₆	Color register 3 (CO3)			CO35		CO33	CO32	CO31		0	0	0	0	0	0	0	0
EA ₁₆	CRT control register (CC)						CC2	CC1	CC0	0	0	0	0	0	0	0	0
EB ₁₆										?							
EC ₁₆	CRT port control register (CRTP)	OP7	OP6	OP5	OUT		R/G/B	VSYC	HSYC	00 ₁₆							
ED ₁₆	CRT clock selection register (CK)							CK1	CK0								0
EE ₁₆	A-D control register 1 (AD1)				ADM4		ADM2	ADM1	ADM0	0	0	0	?	0	0	0	0
EF ₁₆	A-D control register 2 (AD2)			ADC5	ADC4	ADC3	ADC2	ADC1	ADC0	0	0	0	0	0	0	0	0
F0 ₁₆	Timer 1 (TM1)									FF ₁₆							
F1 ₁₆	Timer 2 (TM2)									07 ₁₆							
F2 ₁₆	Timer 3 (TM3)									FF ₁₆							
F3 ₁₆	Timer 4 (TM4)									07 ₁₆							
F4 ₁₆	Timer 12 mode register (T12M)				T12M4	T12M3	T12M2	T12M1	T12M0	0	0		0	0	0	0	0
F5 ₁₆	Timer 34 mode register (T34M)			T34M5	T34M4	T34M3	T34M2	T34M1	T34M0	0	0	0	0	0	0	0	0
F6 ₁₆	PWM5 register (PWM5)									?							
F7 ₁₆										?							
F8 ₁₆										?							
F9 ₁₆	Interrupt input polarity register (RE)			RE5	RE4	RE3											?
FA ₁₆	Test register (TEST)																
FB ₁₆	CPU mode register (CPUM)						CM2									1	0
FC ₁₆	Interrupt request register 1 (IREQ1)	IT3R	VSCR	CRTR	TM4R	TM3R	TM2R	TM1R		0	0	0	0	0	0	0	0
FD ₁₆	Interrupt request register 2 (IREQ2)				MSR		S1R	1T2R	1T1R		0	0	0	0	0	0	0
FE ₁₆	Interrupt control register 1 (ICON1)	IT3E	VSCCE	CRTE	TM4E	TM3E	TM2E	TM1E		0	0	0	0	0	0	0	0
FF ₁₆	Interrupt control register 2 (ICON2)				MSE		S1E	1T2E	1T1E				0		0	0	0

Fig. 4. Memory map of SFR (special function register) (2)

INTERRUPTS

Interrupts can be caused by 13 different sources consisting of 3 external, 9 internal, and 1 software sources. Interrupts are vectored interrupts with priorities shown in Table 1. Reset is also included in the table because its operation is similar to an interrupt.

When an interrupt is accepted,

- (1) The contents of the program counter and processor status register are automatically stored into the stack.
- (2) The interrupt disable flag I is set to "1" and the corresponding interrupt request bit is set to "0."
- (3) The jump destination address stored in the vector address enters the program counter.

Other interrupts are disabled when the interrupt disable flag is set to "1."

All interrupts except the BRK instruction interrupt have an interrupt request bit and an interrupt enable bit. The interrupt request bits are in interrupt request registers 1 and 2 and the interrupt enable bits are in interrupt control registers 1 and 2. Figure 5 shows the structure of the interrupt-related registers.

Interrupts other than the BRK instruction interrupt and reset are accepted when the interrupt enable bit is "1," interrupt request bit is "1," and the interrupt disable flag is "0." The interrupt request bit can be set to "0" by a program, but not set to "1." The interrupt enable bit can be set to "0" and "1" by a program.

Reset is treated as a non-maskable interrupt with the highest priority. Figure 6 shows interrupt control.

Interrupt Causes

- (1) VSYNC and CRT interrupts
The VSYNC interrupt is an interrupt request synchronized with the vertical sync signal.
The CRT interrupt occurs after character block display to the CRT is completed.
- (2) INT1, INT2, INT3 interrupts
With an external interrupt input, the system detects that the level of a pin changes from "L" to "H" or from "H" to "L," and generates an interrupt request. The input active edge can be selected by bits 3, 4 and 5 of the interrupt input polarity register (address 00F9₁₆) : when this bit is "0," a change from "L" to "H" is detected; when it is "1," a change from "H" to "L" is detected. Note that all bits are cleared to "0" at reset.
- (3) Timer 1, 2, 3 and 4 interrupts
An interrupt is generated by an overflow of timer 1, 2, 3 or 4.
- (4) Serial I/O interrupt
This is an interrupt request from the clock synchronous serial I/O function.
- (5) X_{IN}/4096 interrupt
This interrupt occurs regularly with a f(X_{IN})/4096 period. Set bit 0 of the PWM output control register 1 to "0."
- (6) BRK instruction interrupt
This software interrupt has the least significant priority. It does not have a corresponding interrupt enable bit, and it is not affected by the interrupt disable flag I (non-maskable).

Table 1. Interrupt vector addresses and priority

Interrupt source	Priority	Vector addresses	Remarks
Reset	1	FFFF ₁₆ , FFFE ₁₆	Non-maskable
CRT interrupt	2	FFFD ₁₆ , FFFC ₁₆	
INT2 interrupt	3	FFFB ₁₆ , FFFA ₁₆	Active edge selectable
INT1 interrupt	4	FFF9 ₁₆ , FFF8 ₁₆	Active edge selectable
Timer 4 interrupt	5	FFF5 ₁₆ , FFF4 ₁₆	
X _{IN} /4096 interrupt	6	FFF3 ₁₆ , FFF2 ₁₆	
VSYNC interrupt	7	FFF1 ₁₆ , FFF0 ₁₆	
Timer 3 interrupt	8	FFEF ₁₆ , FFEE ₁₆	
Timer 2 interrupt	9	FFED ₁₆ , FFEC ₁₆	
Timer 1 interrupt	10	FFEB ₁₆ , FFEA ₁₆	
Serial I/O interrupt	11	FFE9 ₁₆ , FFE8 ₁₆	
INT3 interrupt	12	FFE5 ₁₆ , FFE4 ₁₆	Active edge selectable
BRK instruction interrupt	13	FFDF ₁₆ , FFDE ₁₆	Non-maskable (software interrupt)

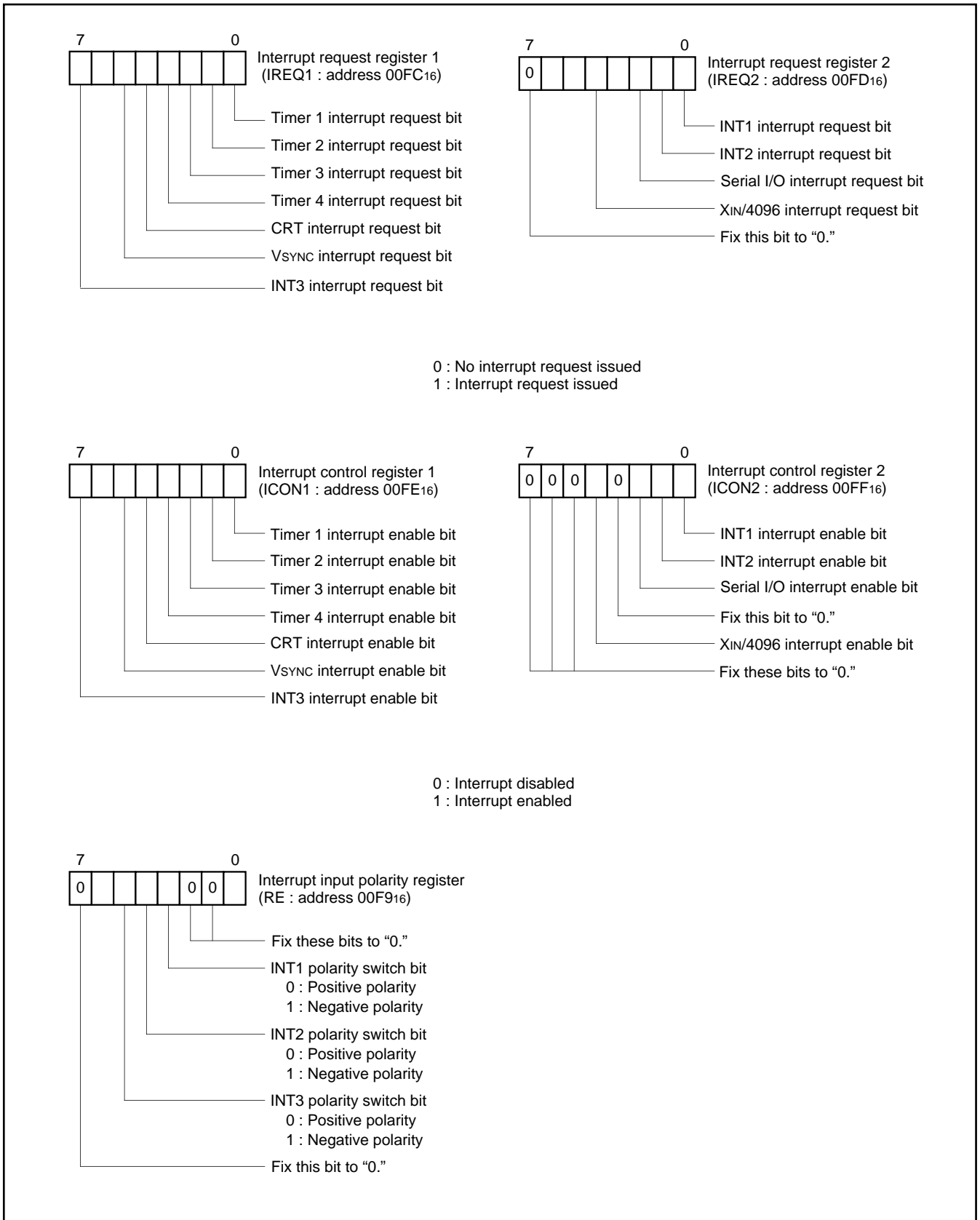

Fig. 5. Structure of interrupt-related registers

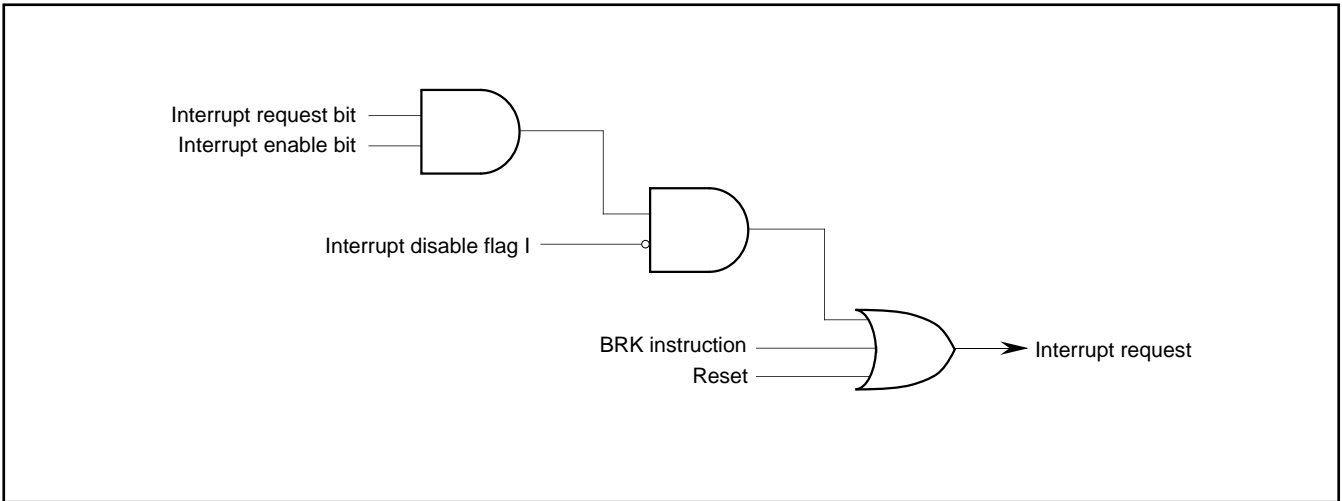

Fig. 6. Interrupt control

TIMERS

The M37220M3-XXXSP has 4 timers: timer 1, timer 2, timer 3, and timer 4. All timers are 8-bit timers with the 8-bit timer latch. The timer block diagram is shown in Figure 8.

All of the timers count down and their divide ratio is $1/(n+1)$, where n is the value of timer latch. The value is set to a timer at the same time by writing a count value to the corresponding timer latch (addresses 00F0₁₆ to 00F3₁₆).

The count value is decremented by 1. The timer interrupt request bit is set to "1" by a timer overflow at the next count pulse after the count value reaches "00₁₆".

(1) Timer 1

Timer 1 can select one of the following count sources:

- $f(X_{IN})/16$
- $f(X_{IN})/4096$

The count source of timer 1 is selected by setting bit 0 of the timer 12 mode register (address 00F4₁₆).

Timer 1 interrupt request occurs at timer 1 overflow.

(2) Timer 2

Timer 2 can select one of the following count sources:

- $f(X_{IN})/16$
- Timer 1 overflow signal
- External clock from the P24/TIM2 pin

The count source of timer 2 is selected by setting bits 4 and 1 of the timer 12 mode register (address 00F4₁₆). When timer 1 overflow signal is a count source for the timer 2, the timer 1 functions as an 8-bit prescaler.

Timer 2 interrupt request occurs at timer 2 overflow.

(3) Timer 3

Timer 3 can select one of the following count sources:

- $f(X_{IN})/16$
- External clock from the HSYNC pin
- External clock from the P23/TIM3 pin

The count source of timer 3 is selected by setting bits 5 and 0 of the timer 34 mode register (address 00F5₁₆).

Timer 3 interrupt request occurs at timer 3 overflow.

(4) Timer 4

Timer 4 can select one of the following count sources:

- $f(X_{IN})/16$
- $f(X_{IN})/2$
- Timer 3 overflow signal

The count source of timer 3 is selected by setting bits 4 and 1 of the timer 34 mode register (address 00F5₁₆). When timer 3 overflow signal is a count source for the timer 4, the timer 3 functions as an 8-bit prescaler.

Timer 4 interrupt request occurs at timer 4 overflow.

At reset, timers 3 and 4 are connected by hardware and "FF₁₆" is automatically set in timer 3; "07₁₆" in timer 4. The $f(X_{IN})/16$ is selected as the timer 3 count source. The internal reset is released by timer 4 overflow at these state, the internal clock is connected.

At execution of the STP instruction, timers 3 and 4 are connected by hardware and "FF₁₆" is automatically set in timer 3; "07₁₆" in timer 4. However, the $f(X_{IN})/16$ is not selected as the timer 3 count source. So set bit 0 of the timer 34 mode register (address 00F5₁₆) to "0" before the execution of the STP instruction ($f(X_{IN})/16$ is selected as the timer 3 count source). The internal STP state is released by timer 4 overflow at these state, the internal clock is connected.

Because of this, the program starts with the stable clock.

The structure of timer-related registers is shown in Figure 7.

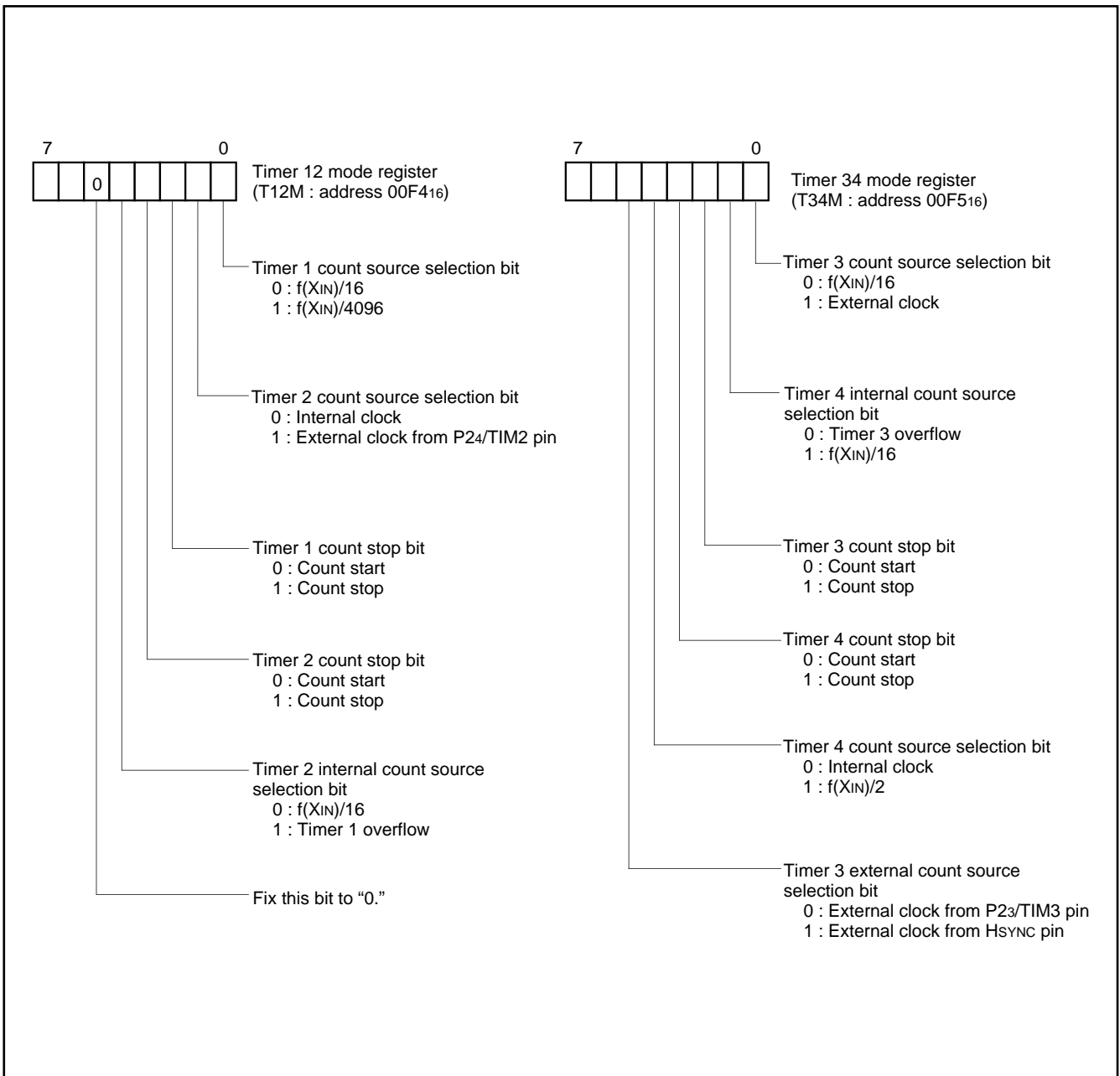

Fig. 7. Structure of timer-related registers

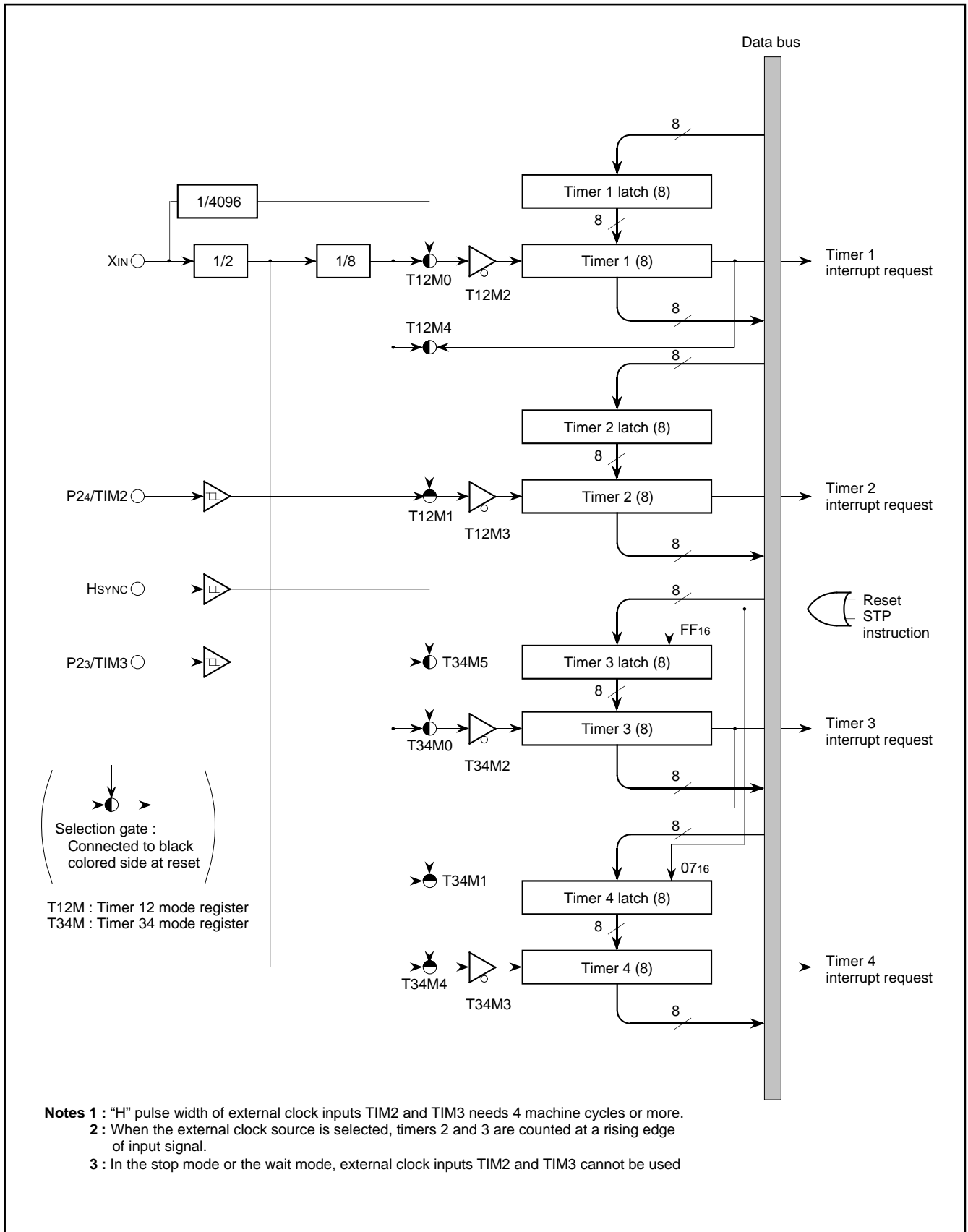

Fig. 8. Timer block diagram

SERIAL I/O

The M37220M3-XXXSP has a built-in serial I/O which can either transmit or receive 8-bit data in serial in the clock synchronous mode.

The serial I/O block diagram is shown in Figure 9. The synchronizing clock I/O pin (SCLK), and data I/O pins (SOUT, SIN) also function as port P2.

Bit 2 of the serial I/O mode register (address 00DC16) selects whether the synchronizing clock is supplied internally or externally (from the P20/SCLK pin). When an internal clock is selected, bits 1 and 0 select whether $f(XIN)$ is divided by 4, 16, 32, or 64. Bit 3 selects whether port P2 is used for serial I/O or not. To use the P22/SIN pin as the SIN pin, set the bit 2 of the port P2 direction register (address 00C516) to "0."

The operation of the serial I/O function is described below. The function of the serial I/O differs depending on the clock source; external clock or internal clock.

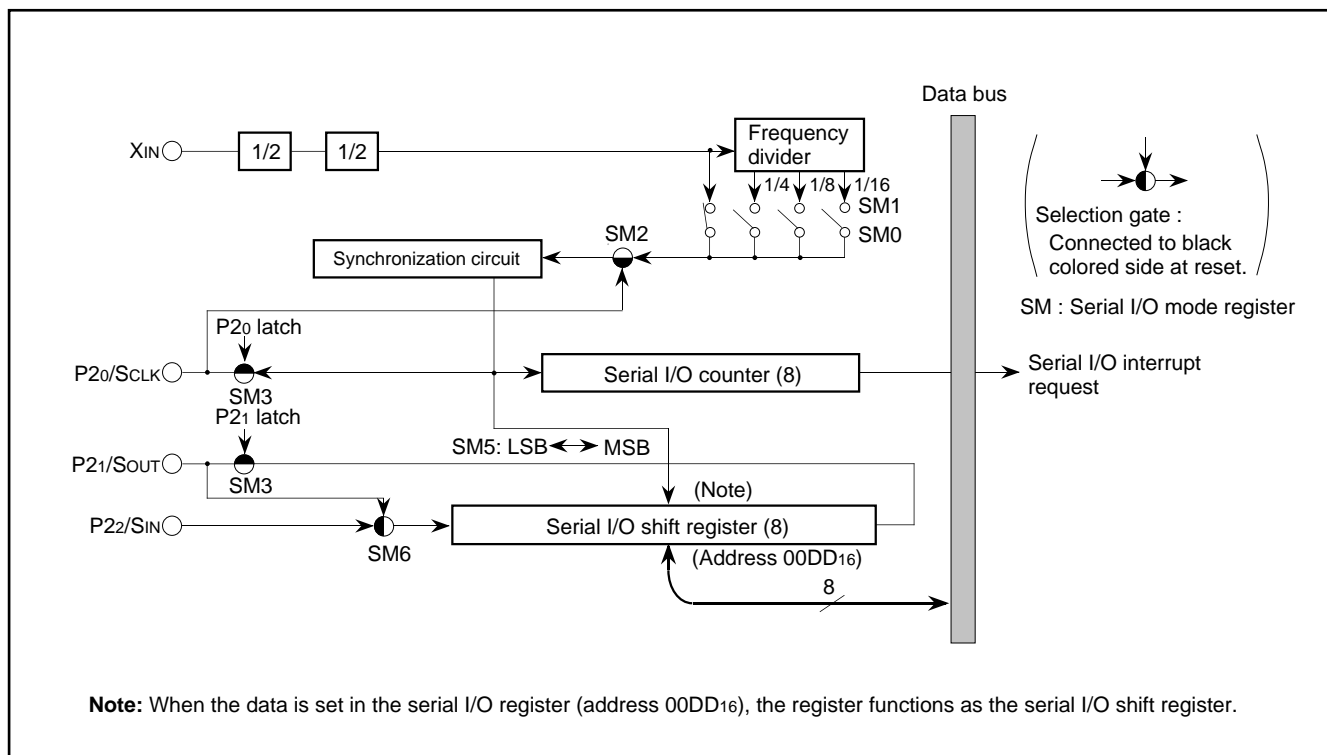

Fig. 9. Serial I/O block diagram

Internal clock—the serial I/O counter is set to “7” during write cycle into the serial I/O register (address 00DD16), and transfer clock goes “H” forcibly. At each falling edge of the transfer clock after the write cycle, serial data is output from the SOUT pin. Transfer direction can be selected by bit 5 of the serial I/O mode register. At each rising edge of the transfer clock, data is input from the SIN pin and data in the serial I/O register is shifted 1 bit.

After the transfer clock has counted 8 times, the serial I/O counter becomes “0” and the transfer clock stops at “H.” At this time the interrupt request bit is set to “1.”

External clock—when an external clock is selected as the clock source, the interrupt request is set to “1” after the transfer clock has counted 8 times. However, transfer operation does not stop, so control the clock externally. Use the external clock of 1MHz or less with a duty cycle of 50%.

The serial I/O timing is shown in Figure 11. When using an external clock for transfer, the external clock must be held at “H” for initializing the serial I/O counter. When switching between an internal clock and an external clock, do not switch during transfer. Also, be sure to initialize the serial I/O counter after switching.

Notes 1: On programming, note that the serial I/O counter is set by writing to the serial I/O register with the bit managing instructions as SEB and CLB instructions.

2: When an external clock is used as the synchronizing clock, write transmit data to the serial I/O register at “H” of the transfer clock input level.

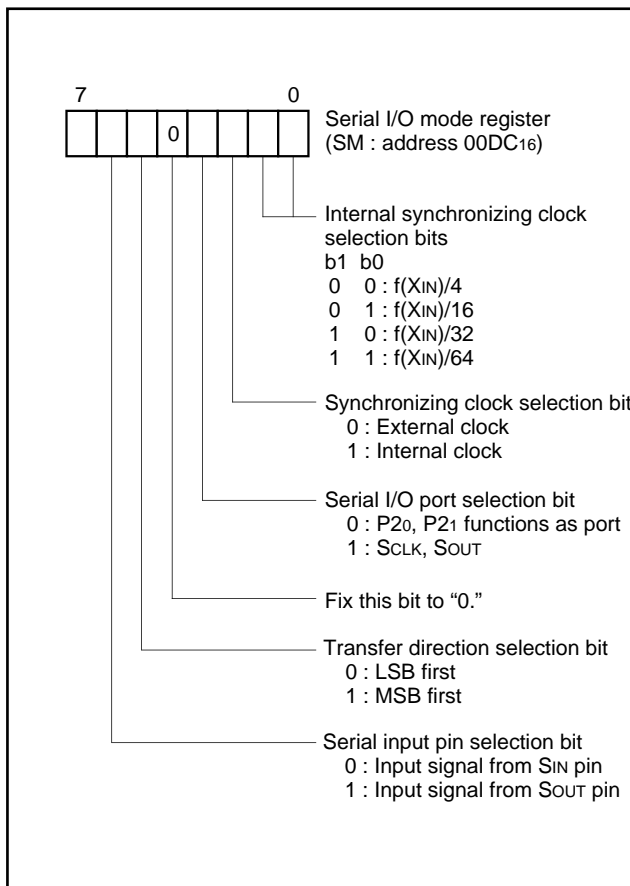

Fig. 10. Structure of serial I/O mode register

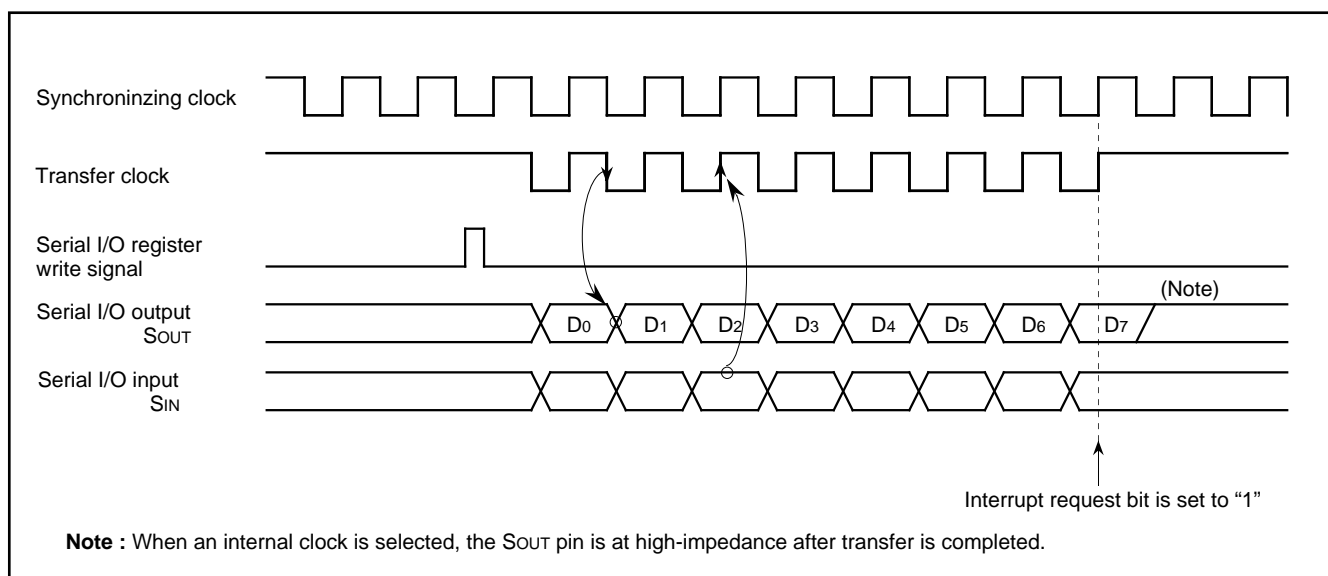

Fig. 11. Serial I/O timing (for LSB first)

Serial I/O Common Transmission/Reception Mode

By writing "1" to bit 6 of the serial I/O mode register, signals SIN and SOUT are switched internally to be able to transmit or receive the serial data.

Figure 12 shows signals on serial I/O common transmission/reception mode.

Note: When receiving the serial data after writing "FF16" to the serial I/O register.

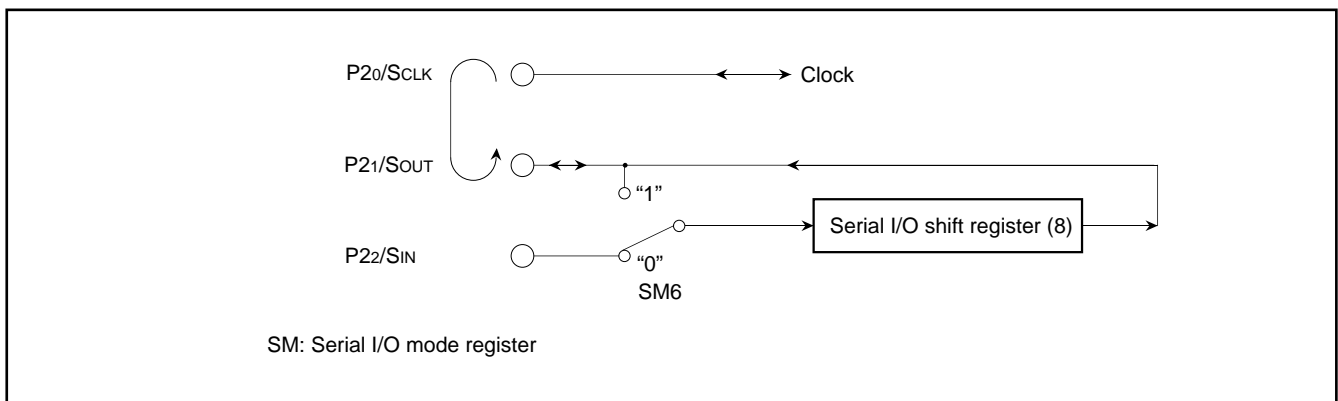

Fig. 12. Signals on serial I/O common transmission/reception mode

PWM OUTPUT FUNCTION

The M37220M3-XXXSP is equipped with a 14-bit PWM (DA) and six 8-bit PWMs (PWM0–PWM5). DA has a 14-bit resolution with the minimum resolution bit width of 0.25 μ s (for $f(X_{IN}) = 8$ MHz) and a repeat period of 4096 μ s. PWM0–PWM5 have the same circuit structure and an 8-bit resolution with minimum resolution bit width of 4 μ s (for $f(X_{IN}) = 8$ MHz) and repeat period of 1024 μ s.

Figure 13 shows the PWM block diagram. The PWM timing generating circuit applies individual control signals to PWM0–PWM5 using $f(X_{IN})$ divided by 2 as a reference signal.

(1) Data Setting

When outputting DA, first set the high-order 8 bits to the DA-H register (address 00CE16), then the low-order 6 bits to the DA-L register (address 00CF16). When outputting PWM0–PWM5, set 8-bit output data in the PWMi register (i means 0 to 5; addresses 00D016 to 00D416, 00F616).

(2) Transmitting Data from Register to PWM circuit

Data transfer from the 8-bit PWM register to 8-bit PWM circuit is executed at writing data to the register.

The signal output from the 8-bit PWM output pin corresponds to the contents of this register.

Also, data transfer from the DA register (addresses 00CE16 and 00CF16) to the 14-bit PWM circuit is executed at writing data to the DA-L register (address 00CF16). Reading from the DA-H register (address 00CE16) means reading this transferred data. Accordingly, it is possible to confirm the data being output from the D-A output pin by reading the DA register.

(3) Operating of 8-bit PWM

The following is the explanation about PWM operation.

At first, set the bit 0 of PWM output control register 1 (address 00D516) to "0" (at reset, bit 0 is already set to "0" automatically), so that the PWM count source is supplied.

PWM0–PWM5 are also used as pins P00–P05 respectively. For PWM0–PWM5, set the corresponding bits of the port P0 direction register to "1" (output mode). And select each output polarity by bit 3 of the PWM output control register 2 (address 00D616). Then, set bits 2 to 7 of the PWM output control register 1 to "1" (PWM output). The PWM waveform is output from the PWM output pins by setting these registers.

Figure 14 shows the 8-bit PWM timing. One cycle (T) is composed of 256 (2^8) segments. The 8 kinds of pulses relative to the weight of each bit (bits 0 to 7) are output inside the circuit during 1 cycle. Refer to Figure 14 (a). The 8-bit PWM outputs waveform which is the logical sum (OR) of pulses corresponding to the contents of bits 0 to 7 of the 8-bit PWM register. Several examples are shown in Figure 14 (b). 256 kinds of output ("H" level area: 0/256 to 255/256) are selected by changing the contents of the PWM register. A length of entirely "H" output cannot be output, i.e. 256/256.

(4) Operating of 14-bit PWM

As with 8-bit PWM, set the bit 0 of the PWM output control register 1 (address 00D516) to "0" (at reset, bit 0 is already set to "0" automatically), so that the PWM count source is supplied. Next, select the output polarity by bit 2 of the PWM output control register 2 (address 00D616). Then, the 14-bit PWM outputs from the D-A output pin by setting bit 1 of the PWM output control register 1 to "0" (at reset, this bit already set to "0" automatically) to select the DA output.

The output example of the 14-bit PWM is shown in Figure 15.

The 14-bit PWM divides the data of the DA latch into the low-order 6 bits and the high-order 8 bits.

The fundamental waveform is determined with the high-order 8-bit data "DH." A "H" level area with a length $\tau \times DH$ ("H" level area of fundamental waveform) is output every short area of "t" = 256 τ = 64 μ s (τ is the minimum resolution bit width of 0.25 μ s). The "H" level area increase interval (t_m) is determined with the low-order 6-bit data "DL." The "H" level are of smaller intervals "tm" shown in Table 2 is longer by τ than that of other smaller intervals in PWM repeat period "T" = 64t. Thus, a rectangular waveform with the different "H" width is output from the D-A pin. Accordingly, the PWM output changes by τ unit pulse width by changing the contents of the DA-H and DA-L registers. A length of entirely "H" output cannot be output, i. e. 256/256.

(5) Output after Reset

At reset, the output of port P00–P05 is in the high-impedance state, and the contents of the PWM register and the PWM circuit are undefined. Note that after reset, the PWM output is undefined until setting the PWM register.

SINGLE-CHIP 8-BIT CMOS MICROCOMPUTER for VOLTAGE SYNTHESIZER
with ON-SCREEN DISPLAY CONTROLLER

Table 2. Relation between the low-order 6-bit data and high-level area increase interval

Low-order 6 bits of data	Area longer by τ than that of other t_m ($m = 0$ to 63)
0 0 0 0 0 0 ^{LSB}	Nothing
0 0 0 0 0 1	$m = 32$
0 0 0 0 1 0	$m = 16, 48$
0 0 0 1 0 0	$m = 8, 24, 40, 56$
0 0 1 0 0 0	$m = 4, 12, 20, 28, 36, 44, 52, 60$
0 1 0 0 0 0	$m = 2, 6, 10, 14, 18, 22, 26, 30, 34, 38, 42, 46, 50, 54, 58, 62$
1 0 0 0 0 0	$m = 1, 3, 5, 7, \dots, 57, 59, 61, 63$

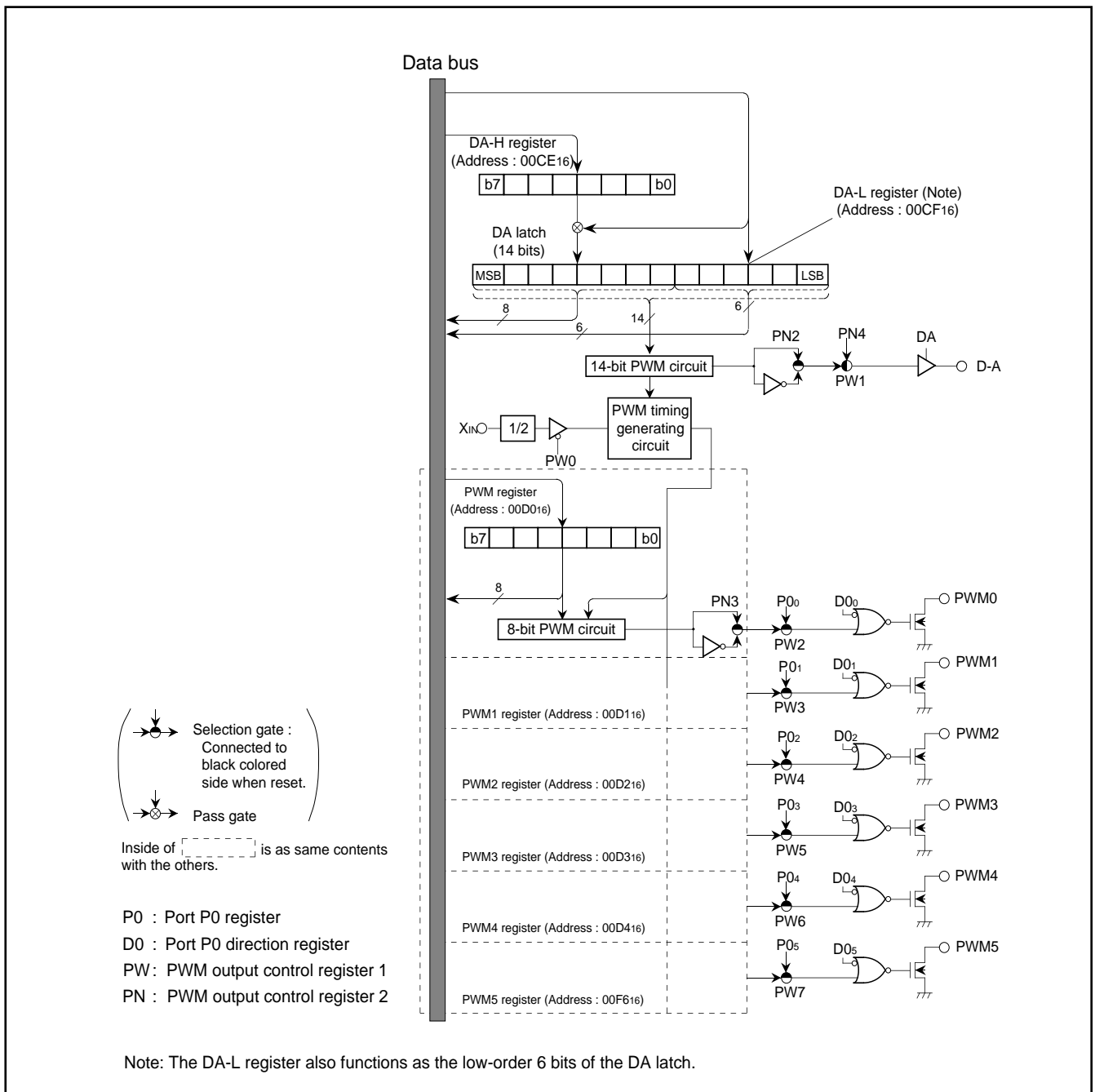

Fig. 13. PWM block diagram

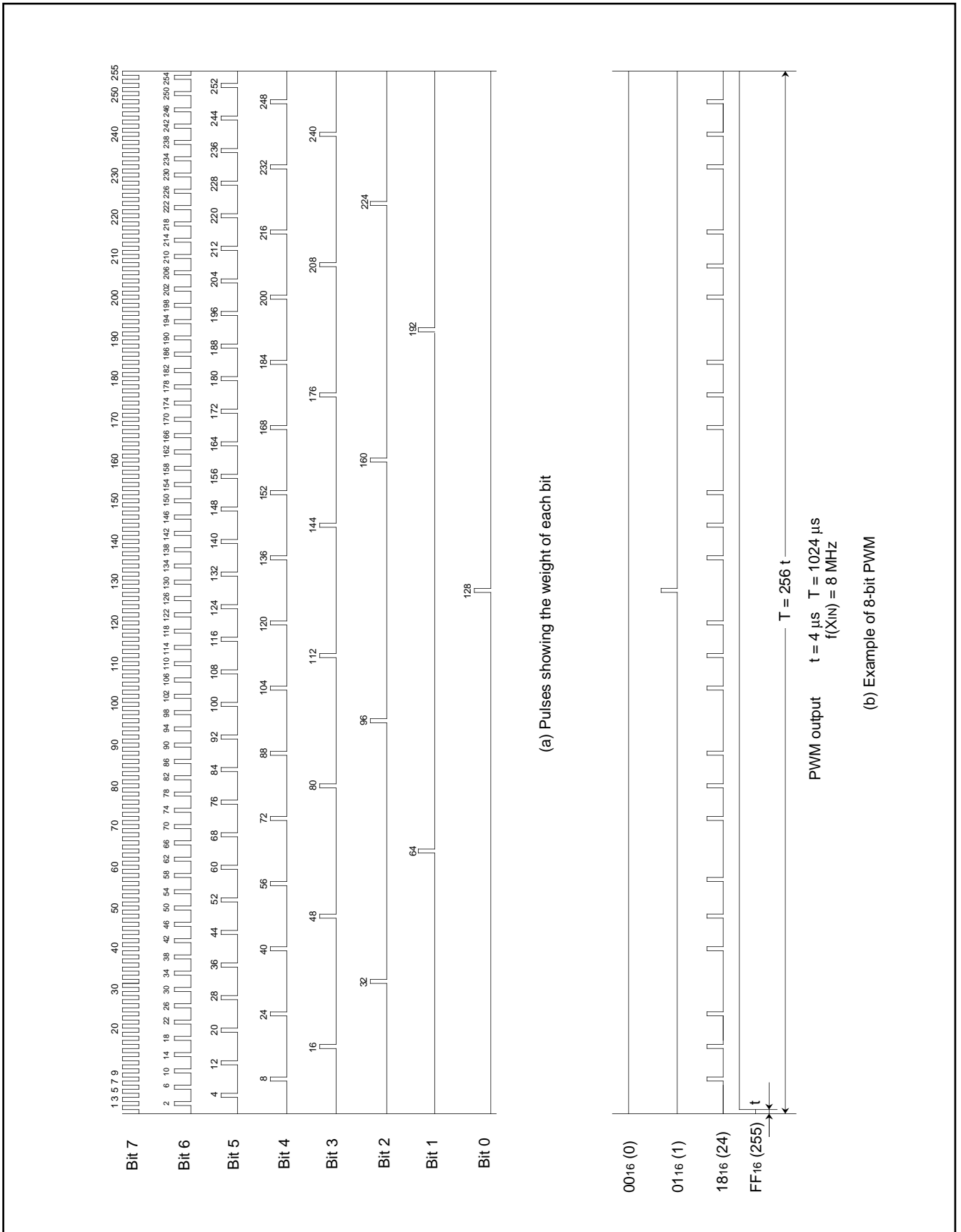

Fig. 14. 8-bit PWM timing

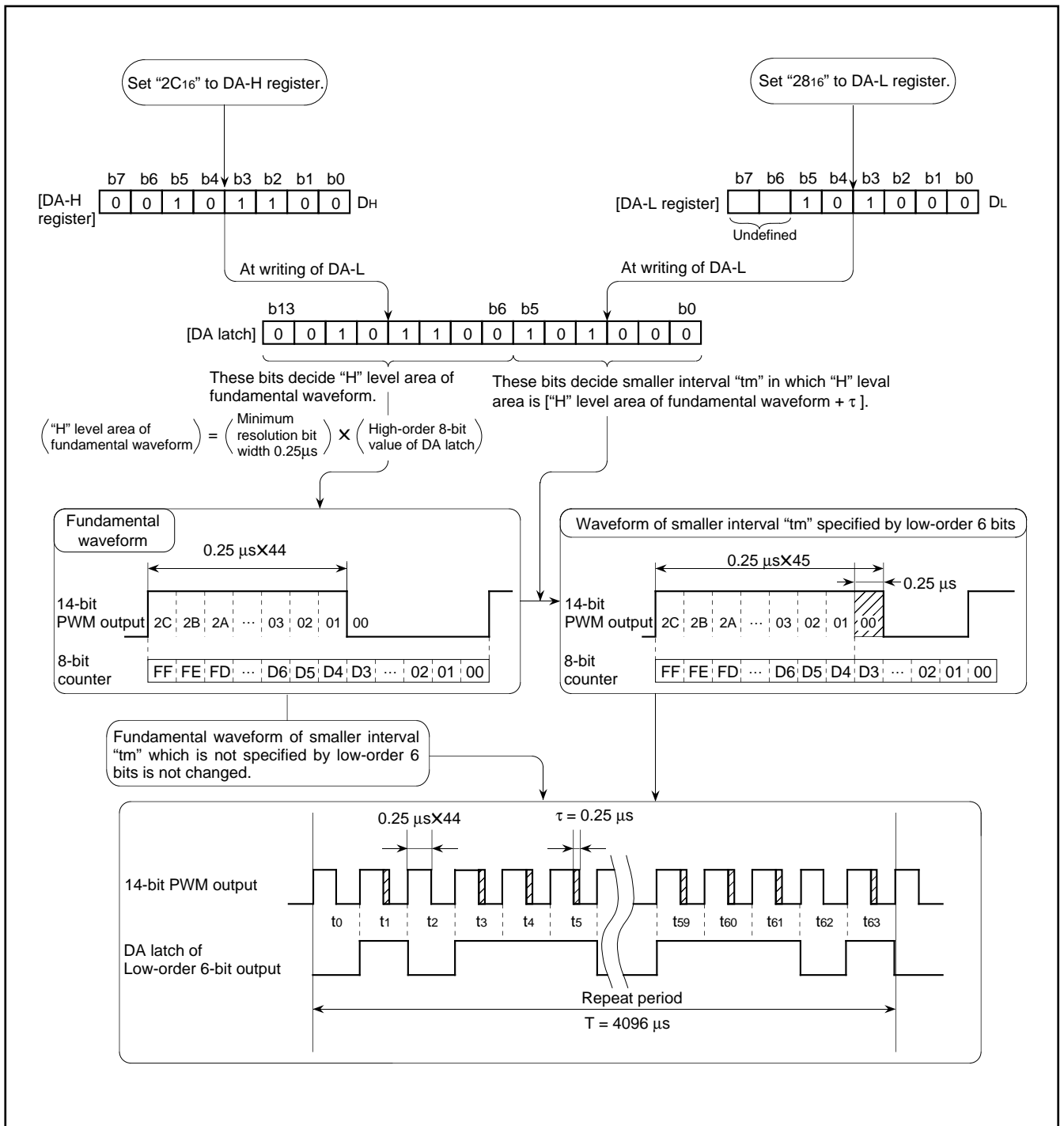

Fig. 15. 14-bit PWM output example (f(XIN)= 8 MHz)

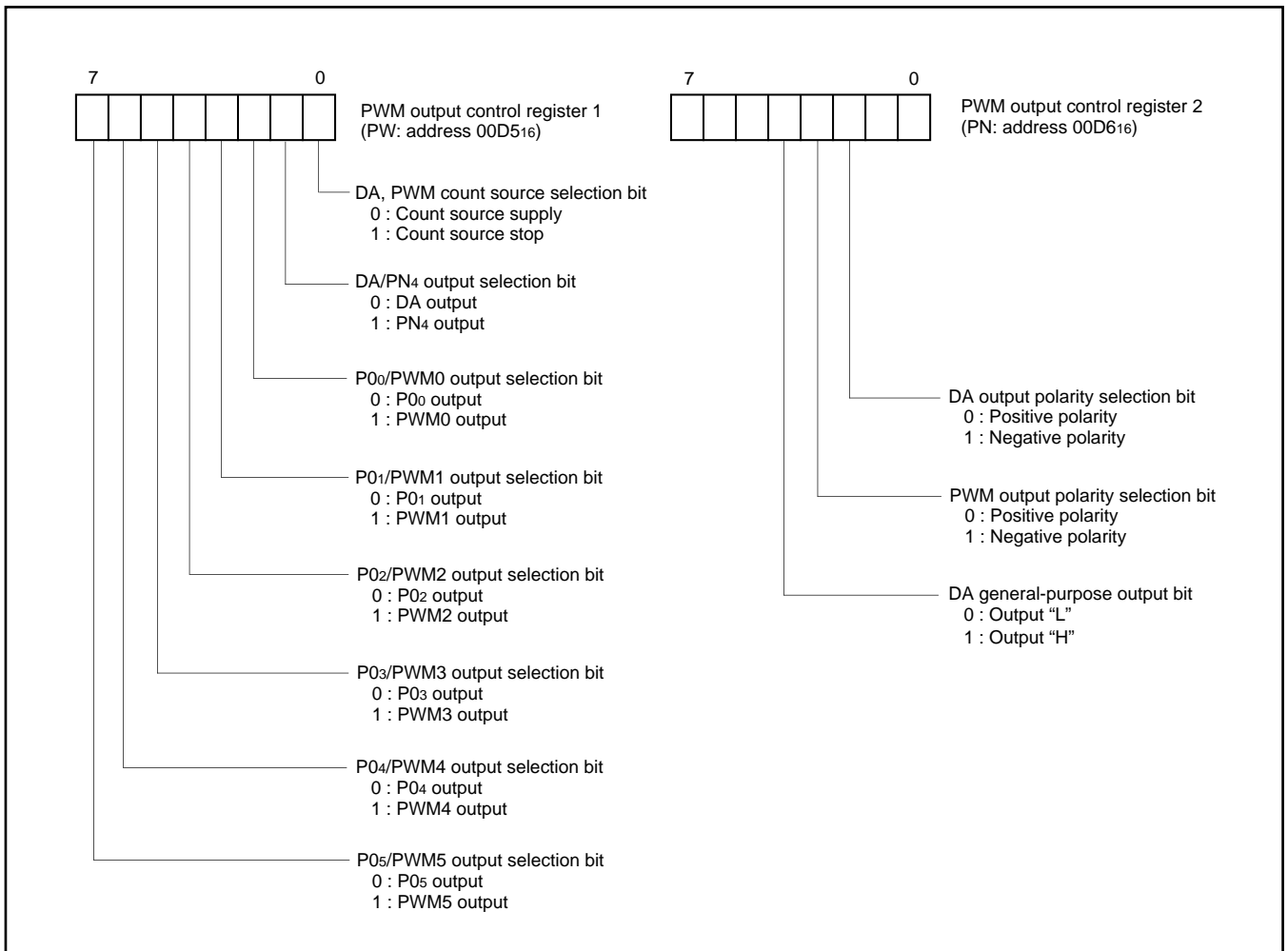

Fig. 16. Structure of PWM-related registers

A-D COMPARATOR

A-D comparator consists of 6-bit D-A converter and comparator. A-D comparator block diagram is shown in Figure 19.

The reference voltage "Vref" for D-A conversion is set by bits 0 to 5 of the A-D control register 2 (address 00EF16).

The comparison result of the analog input voltage and the reference voltage "Vref" is stored in bit 4 of the A-D control register 1 (address 00EE16).

For A-D comparison, set "0" to corresponding bits of the direction register to use ports as analog input pins. Write the data for select of analog input pins to bits 0 to 2 of the A-D control register 1 and write the digital value corresponding to Vref to be compared to the bits 0 to 5 of the A-D control register 2. The voltage comparison starts by writing to the A-D control register 2, and it is completed after 16 machine cycles (NOP instruction X 8).

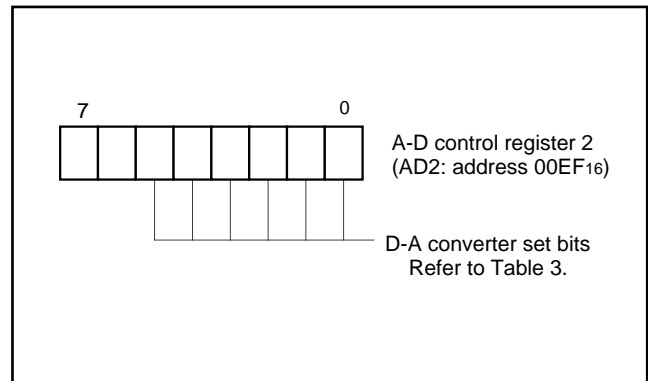

Fig.18. Structure of A-D control register 2

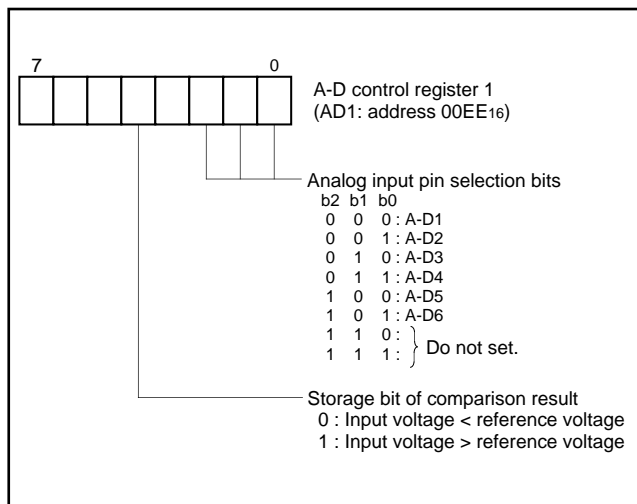

Fig. 17. Structure of A-D control register 1

Table 3. Relation between contents of A-D control register 2 and reference voltage "Vref"

A-D control register 2						Reference voltage "Vref"
Bit 5	Bit 4	Bit 3	Bit 2	Bit 1	Bit 0	
0	0	0	0	0	0	1/128 Vcc
0	0	0	0	0	1	3/128 Vcc
0	0	0	0	1	0	5/128 Vcc
⋮	⋮	⋮	⋮	⋮	⋮	⋮
1	1	1	1	0	1	123/128 Vcc
1	1	1	1	1	0	125/128 Vcc
1	1	1	1	1	1	127/128 Vcc

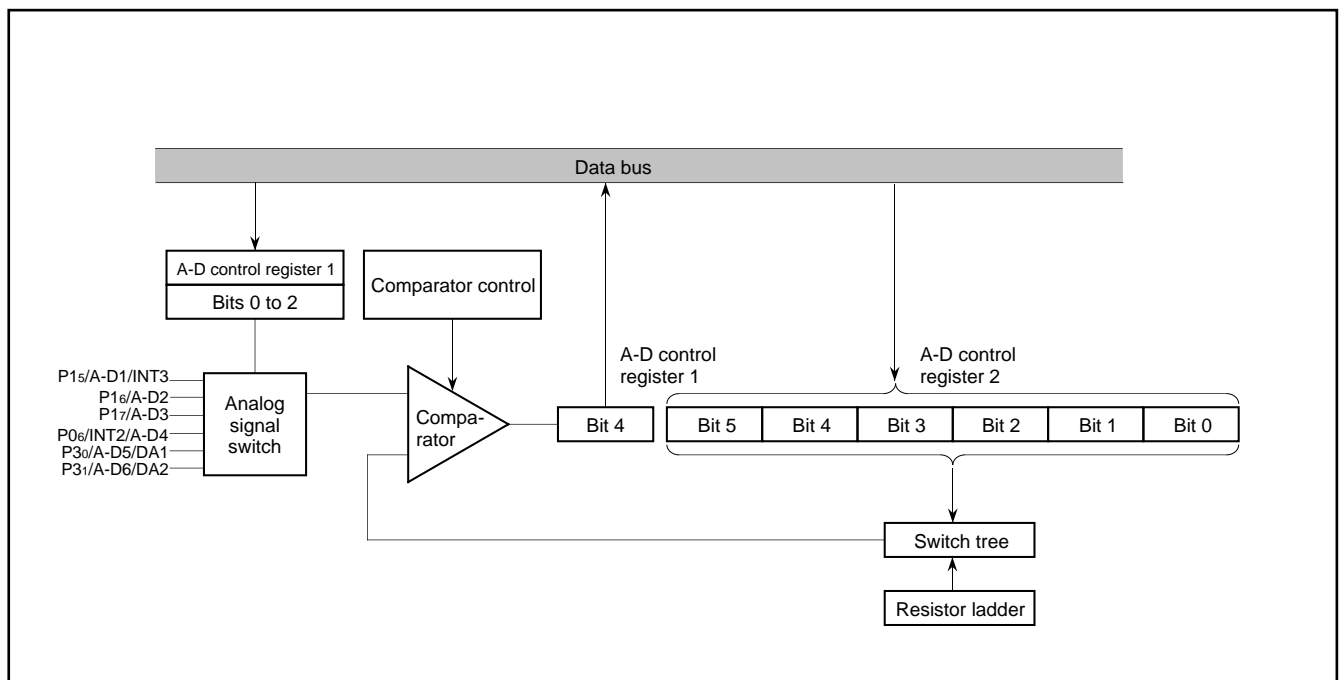

Fig. 19. A-D comparator block diagram

D-A CONVERTER

The M37220M3-XXXSP has 2 D-A converters with 6-bit resolution. D-A converter block diagram is shown in Figure 22.

D-A conversion is performed by setting the value in the DA conversion register. The result of D-A conversion is output from the DA pin by setting "1" to the DA output enable bit of the port P3 output mode control register (bits 2 and 3 at address 00CD16).

The output analog voltage V is determined with the value n (n: decimal number) in the DA conversion register.

$$V = V_{CC} \times \frac{n}{64} \quad (n = 0 \text{ to } 63)$$

The DA output does not build in a buffer, so connect an external buffer when driving a low-impedance load.

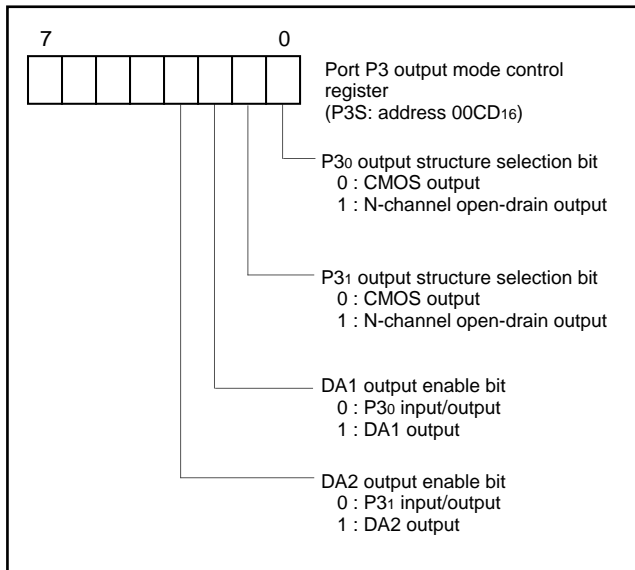

Fig.21. Structure of port P3 output mode register

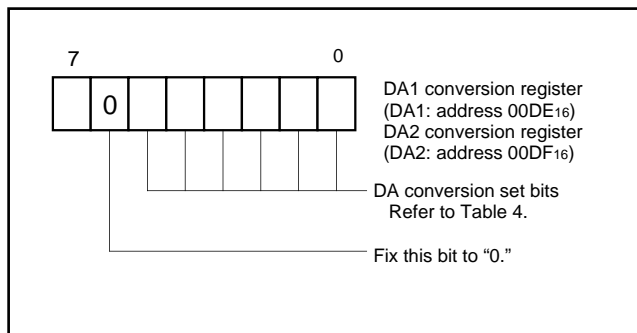

Fig. 20 Structure of D-A converter register

Table 4. Relation between contents of D-A conversion register and output voltage

D-A conversion register						Output voltage "V"
Bit 5	Bit 4	Bit 3	Bit 2	Bit 1	Bit 0	
0	0	0	0	0	0	0/64 V _{CC}
0	0	0	0	0	1	1/64 V _{CC}
0	0	0	0	1	0	2/64 V _{CC}
⋮	⋮	⋮	⋮	⋮	⋮	⋮
1	1	1	1	0	1	61/64 V _{CC}
1	1	1	1	1	0	62/64 V _{CC}
1	1	1	1	1	1	63/64 V _{CC}

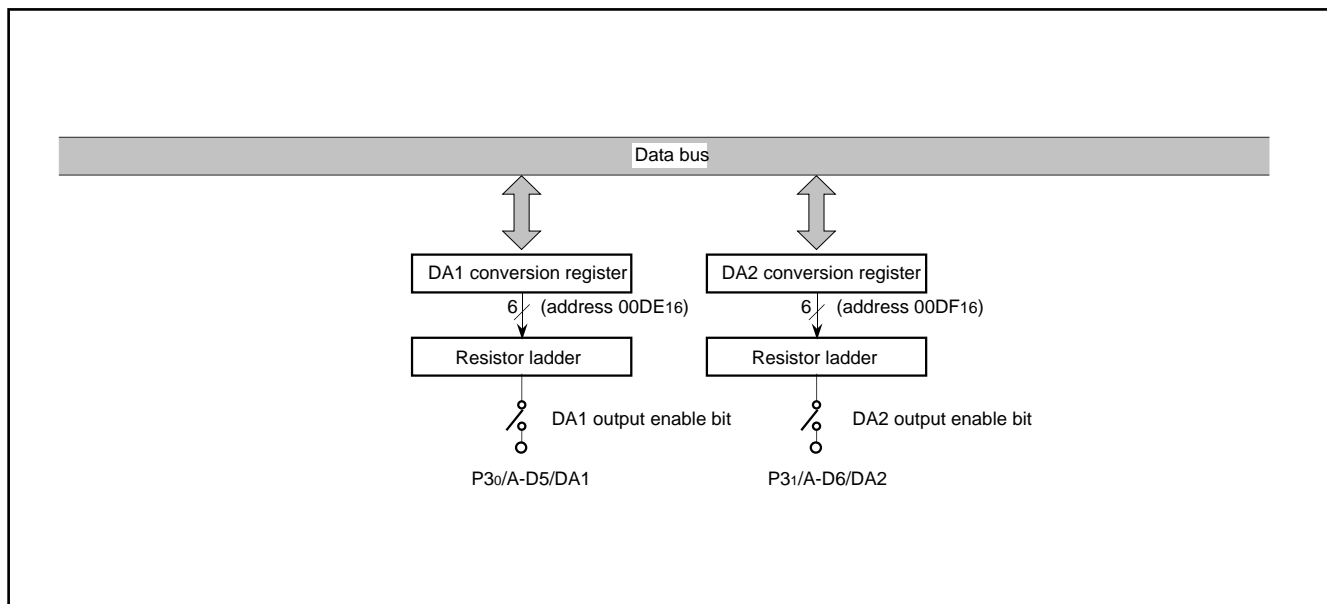

Fig. 22. D-A converter block diagram

CRT DISPLAY FUNCTIONS

(1) Outline of CRT Display Functions

Table 5 outlines the CRT display functions of the M37220M3-XXXSP. The M37220M3-XXXSP incorporates a CRT display control circuit of 20 characters X 2 lines. CRT display is controlled by the CRT control register. Up to 128 kinds of characters can be displayed. The colors can be specified for each character and up to 4 kinds of colors can be displayed on one screen. A combination of up to 7 colors can be obtained by using each output signal (R, G, and B). Characters are displayed in a 12 X 16 dots configuration to obtain smooth character patterns (refer to Figure 23).

The following shows the procedure how to display characters on the CRT screen.

- ① Write the display character code in the display RAM.
- ② Specify the display color by using the color register.
- ③ Write the color register in which the display color is set in the display RAM.
- ④ Specify the vertical position by using the vertical position register.
- ⑤ Specify the character size by using the character size register.
- ⑥ Specify the horizontal position by using the horizontal position register.
- ⑦ Write the display enable bit to the designated block display flag of the CRT control register. When this is done, the CRT display starts according to the input of the VSYNC signal.

The CRT display circuit has an extended display mode. This mode allows multiple lines (3 lines or more) to be displayed on the screen by interrupting the display each time one line is displayed and rewriting data in the block for which display is terminated by software.

Figure 24 shows the structure of the CRT display control register. Figure 25 shows the block diagram of the CRT display control circuit.

Table 5. Outline of CRT display functions

Parameter		Functions
Number of display characters		24 characters X 2 lines
Dot structure		12 X 16 dots (refer to Figure 23)
Kinds of characters		128 kinds
Kinds of character sizes		3 kinds
Color	Kinds of colors	1 screen: 4 kinds, maximum 7 kinds
	Coloring unit	A character
Display expansion		Possible (multiline display)
Raster coloring		Possible (maximum 7 kinds)

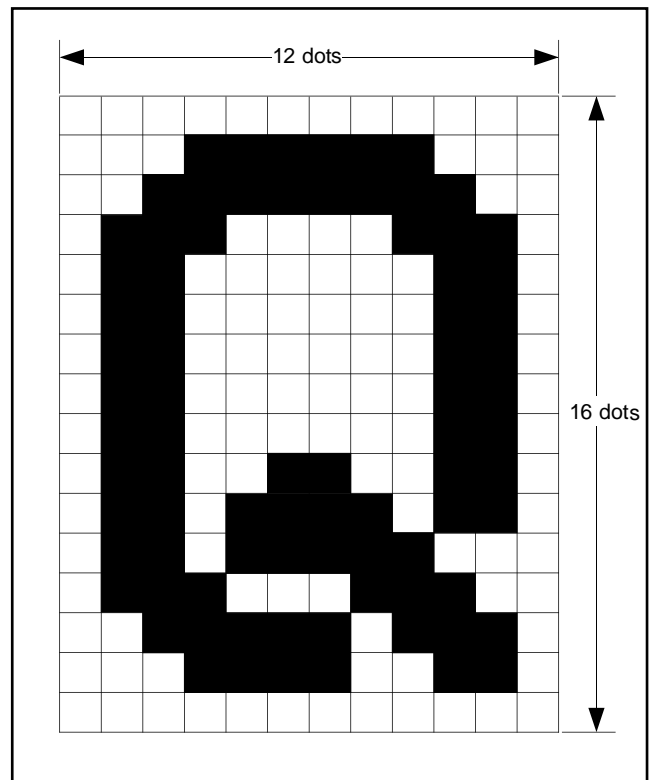

Fig. 23. CRT display character configuration

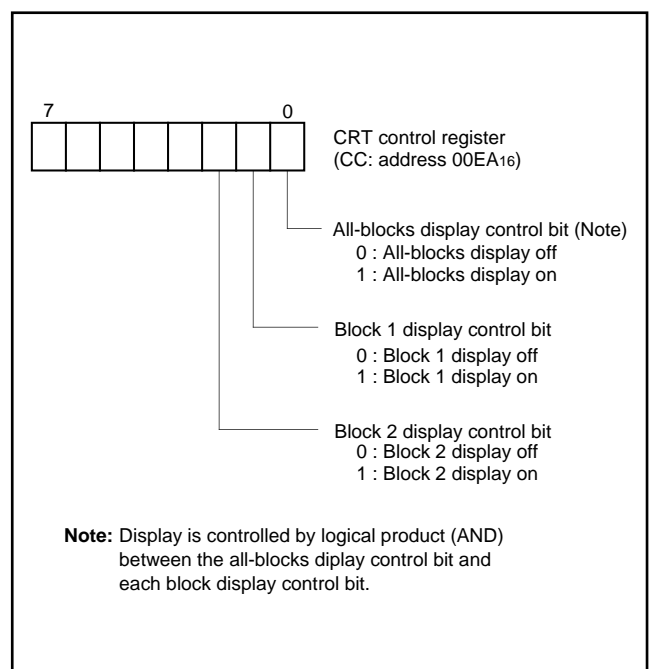

Fig. 24. Structure of CRT control register

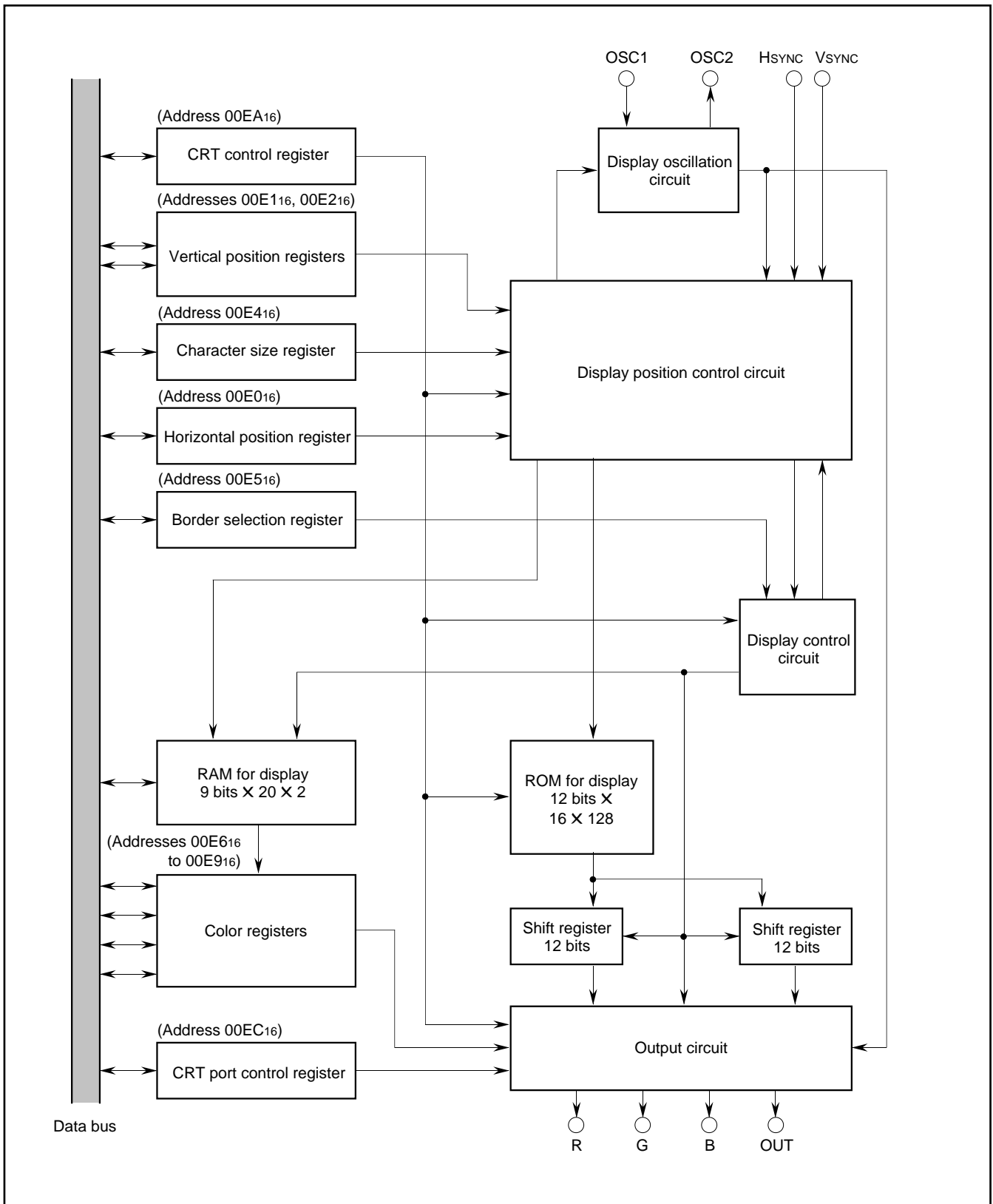

Fig. 25. Block diagram of CRT display control circuit

(2) Display Position

The display positions of characters are specified in units called a "block." There are 2 blocks, block 1 and block 2. Up to 20 characters can be displayed in each block (refer to (4) Memory for display).

The display position of each block can be set in both horizontal and vertical directions by software.

The display position in the horizontal direction can be selected for all blocks in common from 64-step display positions in units of 4Tc (Tc = oscillating cycle for display).

The display position in the vertical direction for each block can be selected from 128-step display positions in units of 4 scanning lines.

Block 2 is displayed after the display of block 1 is completed (refer to Figure 26 (a)). Accordingly, if the display of block 2 starts during the display of block 1, only block 1 is displayed. Similarly, when multiline display, block 1 is displayed after the display of block 2 is completed (refer to Figure 26 (b)).

The vertical position can be specified from 128-step positions (4 scanning lines per a step) for each block by setting values "00₁₆" to "7F₁₆" to bits 0 to 6 in the vertical position register (addresses 00E1₁₆ and 00E2₁₆). Figure 28 shows the structure of the vertical position register.

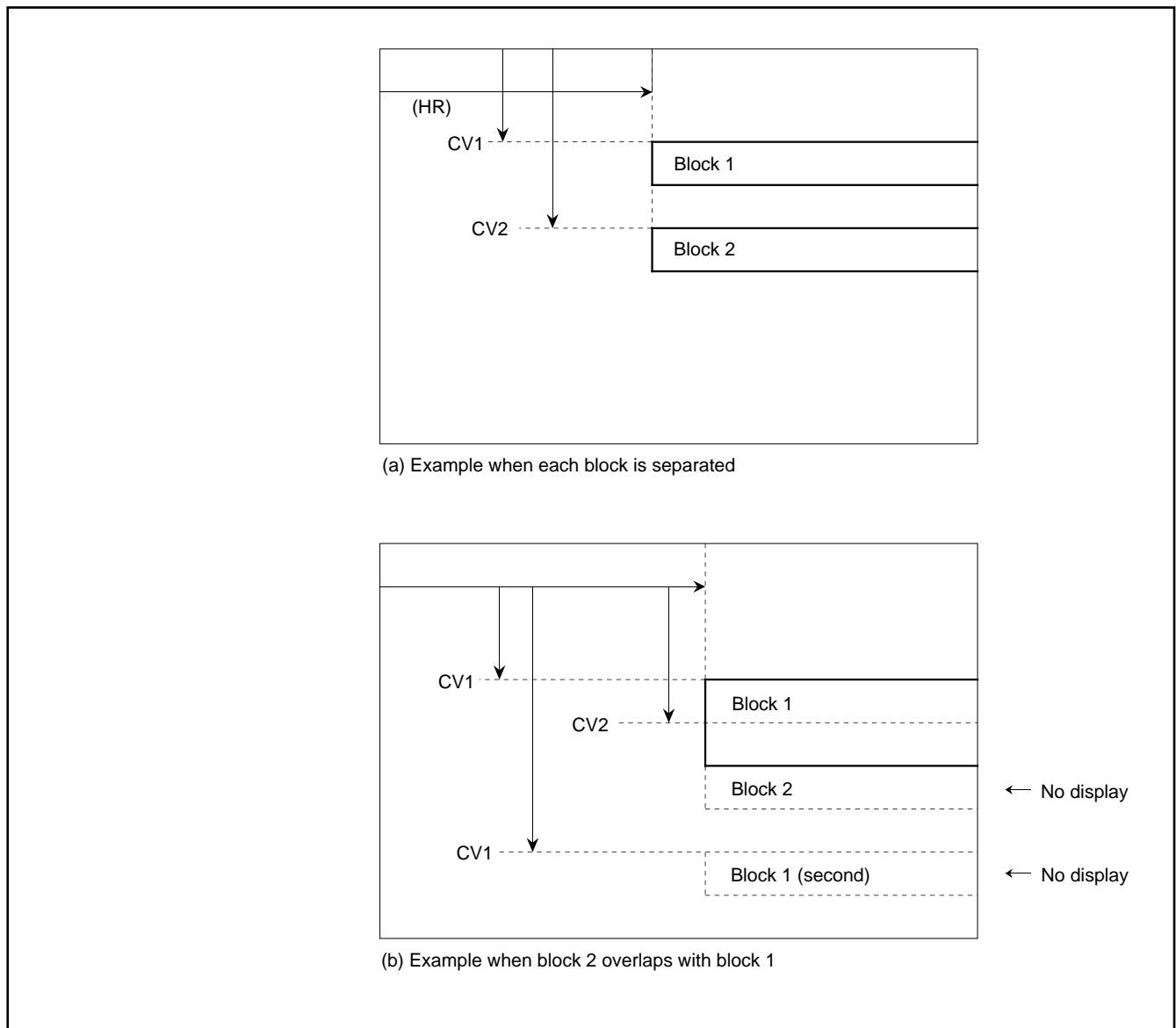

Fig. 26. Display position

The display position in the vertical direction is determined by counting the horizontal sync signal (HSYNC). At this time, it starts to count the rising edge (falling edge) of HSYNC signal from after about 1 machine cycle of rising edge (falling edge) of VSYNC signal. So interval from rising edge (falling edge) of VSYNC signal to rising edge (falling edge) of HSYNC signal needs enough time (2 machine cycles or more) for avoiding jitter. The polarity of HSYNC and VSYNC signals can select with the CRT port control register (address 00EC16). For details, refer to (8) CRT Output Pin Control.

Note: When bits 0 and 1 of the CRT port control register (address 00EC16) are set to "1" (negative polarity), the vertical position is determined by counting falling edge of HSYNC signal after rising edge of VSYNC control signal in the microcomputer (refer to Figure 27).

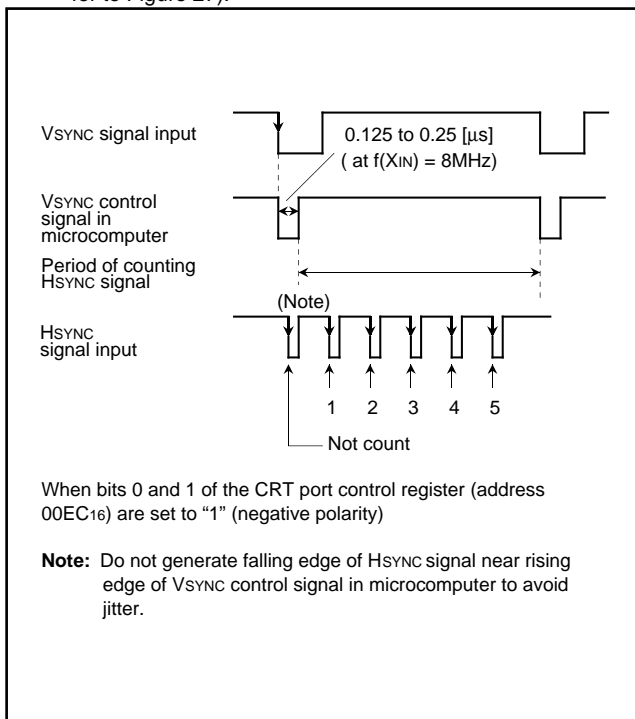

Fig. 27. Supplement explanation for display position

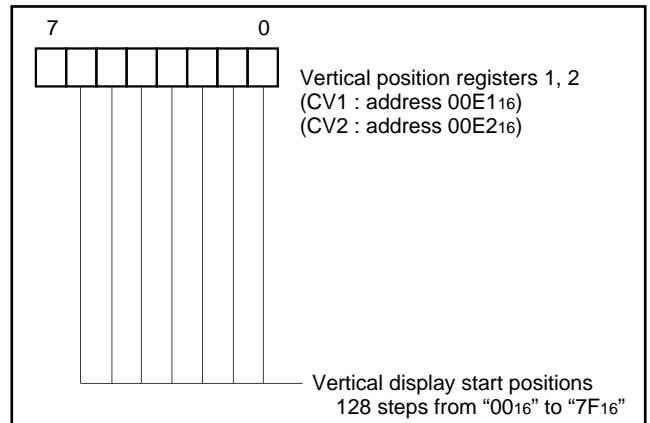

Fig. 28. Structure of vertical position register

The horizontal position is common to all blocks, and can be set in 64 steps (where 1 step is 4TC, TC being the display oscillation period) as values "0016" to "3F16" in bits 0 to 5 of the horizontal position register (address 00E016). The structure of the horizontal position register is shown in Figure 29.

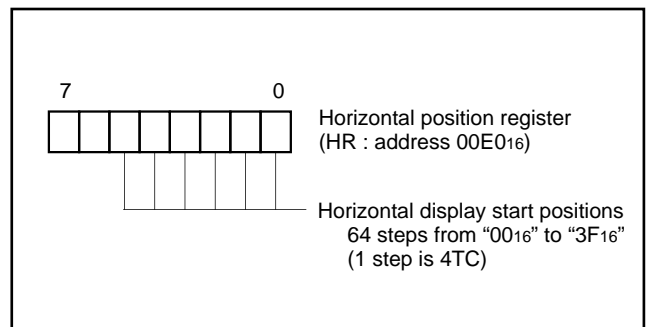

Fig. 29. Structure of horizontal position register

(3) Character Size

The size of characters to be displayed can be from 3 sizes for each block. Use the character size register (address 00E416) to set a character size. The character size of block 1 can be specified by using bits 0 and 1 of the character size register; the character size of block 2 can be specified by using bits 2 and 3. Figure 30 shows the structure of the character size register.

The character size can be selected from 3 sizes: minimum size, medium size and large size. Each character size is determined by the number of scanning lines in the height (vertical) direction and the oscillating cycle for display (T_c) in the width (horizontal) direction. The minimum size consists of [1 scanning line] \times [$1T_c$]; the medium size consists of [2 scanning lines] \times [$2T_c$]; and the large size consists of [3 scanning lines] \times [$3T_c$]. Table 6 shows the relation between the set values in the character size register and the character sizes.

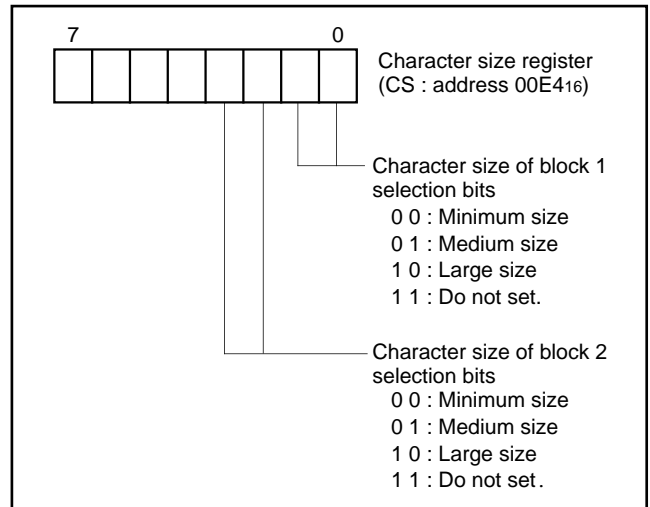

Fig. 30. Structure of character size register

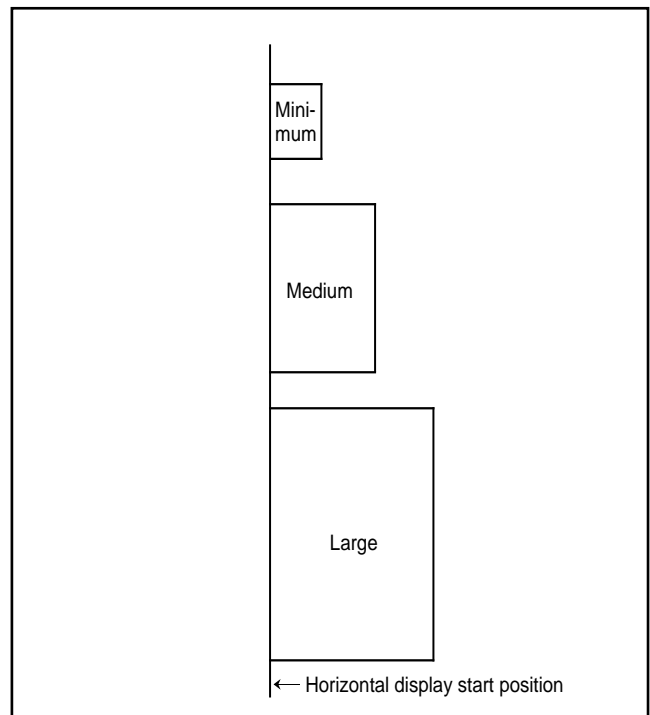

Fig. 31. Display start position of each character size (horizontal direction)

Table 6. Relation between set values in character size register and character sizes

Set values of character size register		Character size	Width (horizontal) direction T_c : oscillating cycle for display	Height (vertical) direction scanning lines
CSn1	CSn0			
0	0	Minimum	$1T_c$	1
0	1	Medium	$2T_c$	2
1	0	Large	$3T_c$	3
1	1	This is not available		

Note: The display start position in the horizontal direction is not affected by the character size. In other words, the horizontal display start position is common to all blocks even when the character size varies with each block (refer to Figure 31).

(4) Memory for Display

There are 2 types of memory for display : CRT display ROM (addresses 10000₁₆ to 10FFF₁₆) used to store character dot data (masked) and CRT display RAM (addresses 0600₁₆ to 06B3₁₆) used to specify the colors of characters to be displayed. The following describes each type of display memory.

① ROM for display (addresses 10000₁₆ to 10FFF₁₆)

The CRT display ROM contains dot pattern data for characters to be displayed. For characters stored in this ROM to be actually displayed, it is necessary to specify them by writing the character code inherent to each character (code determined based on the addresses in the CRT display ROM) into the CRT display RAM. The character code list is shown in Table 7.

The CRT display ROM has a capacity of 4K bytes. Since 32 bytes are required for 1 character data, the ROM can store up to 128 kinds of characters.

The CRT display ROM space is broadly divided into 2 areas. The [vertical 16 dots] X [horizontal (left side) 8 dots] data of display characters are stored in addresses 10000₁₆ to 107FF₁₆; the [vertical 16 dots] X [horizontal (right side) 4 dots] data of display characters are stored in addresses 10800₁₆ to 10FFF₁₆ (refer to Figure 32). Note however that the high-order 4 bits in the data to be written to addresses 10800₁₆ to 10FFF₁₆ must be set to "1" (by writing data "FX₁₆").

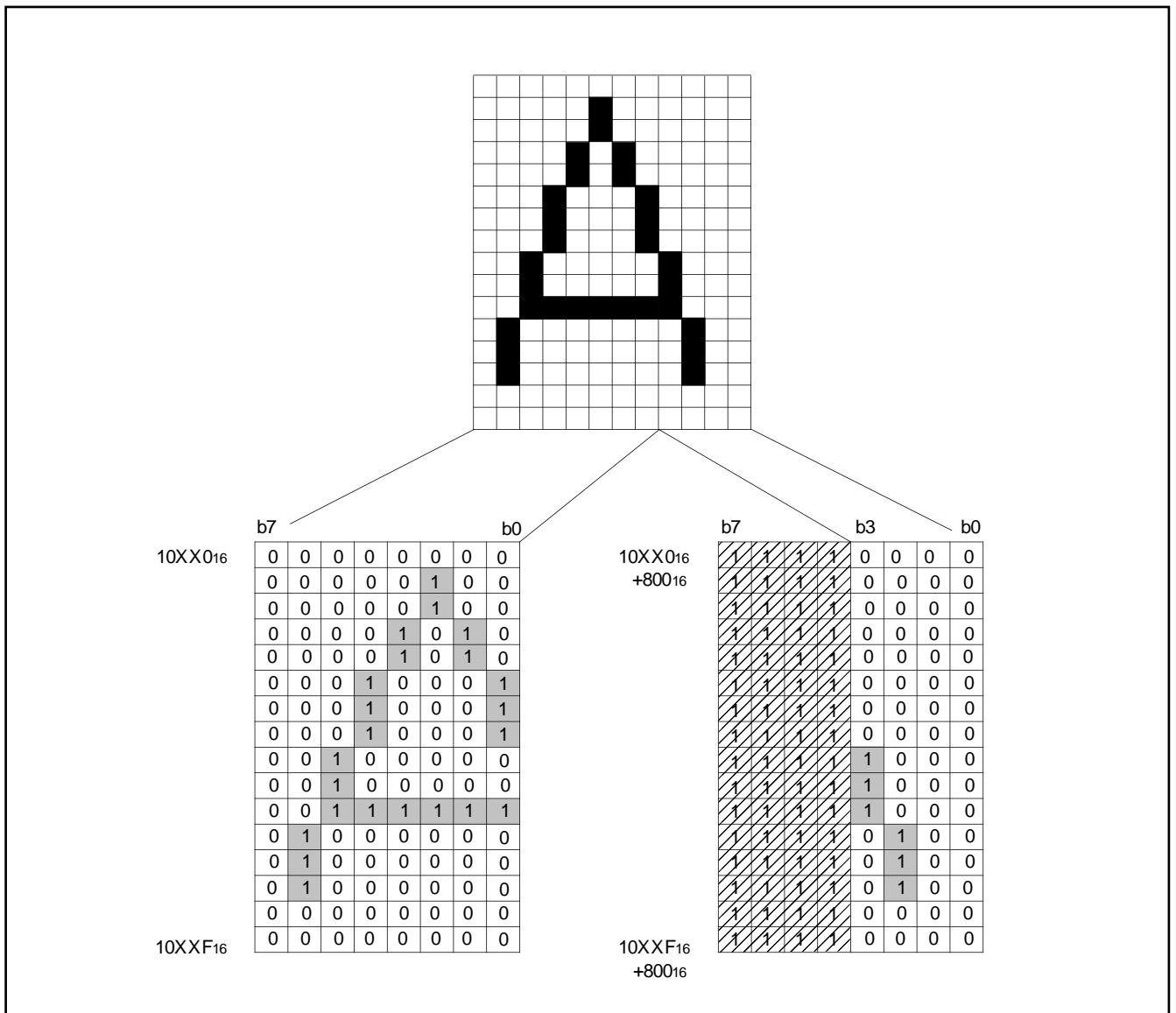

Fig. 32. Display character stored data

SINGLE-CHIP 8-BIT CMOS MICROCOMPUTER for VOLTAGE SYNTHESIZER
with ON-SCREEN DISPLAY CONTROLLER

Table 7. Character code list (partially abbreviated)

Character code	Character data storage address	
	Left 8 dots lines	Right 4 dots lines
00 ₁₆	1000 ₁₆ to 100F ₁₆	1080 ₁₆ to 108F ₁₆
01 ₁₆	1001 ₁₆ to 1001F ₁₆	1081 ₁₆ to 1081F ₁₆
02 ₁₆	1002 ₁₆ to 1002F ₁₆	1082 ₁₆ to 1082F ₁₆
03 ₁₆	1003 ₁₆ to 1003F ₁₆	1083 ₁₆ to 1083F ₁₆
:	:	:
7E ₁₆	107E0 ₁₆ to 107EF ₁₆	10FE0 ₁₆ to 10FEF ₁₆
7F ₁₆	107F0 ₁₆ to 107FF ₁₆	10FF0 ₁₆ to 10FFF ₁₆

② **RAM for display (addresses 0600₁₆ to 06B3₁₆)**

The CRT display RAM is allocated at addresses 0600₁₆ to 06B3₁₆, and is divided into a display character code specification part and display color specification part for each block. Table 8 shows the contents of the CRT display RAM.

For example, to display 1 character position (the left edge) in block 1, write the character code in address 0600₁₆ and write the color register No. to the low-order 2 bits (bits 0 and 1) in address 0680₁₆. The color register No. to be written here is one of the 4 color registers in which the color to be displayed is set in advance. For details on color registers, refer to (5) Color Registers. The structure of the CRT display RAM is shown in Figure 33.

Table 8. Contents of CRT display RAM

Block	Display position (from left)	Character code specification	Color specification
Block 1	1st character	0600 ₁₆	0680 ₁₆
	2nd character	0601 ₁₆	0681 ₁₆
	3rd character	0602 ₁₆	0682 ₁₆
	:	:	:
	18nd character	0611 ₁₆	0691 ₁₆
	19rd character	0612 ₁₆	0692 ₁₆
	20th character	0613 ₁₆	0693 ₁₆
	Not used	0614 ₁₆ to 061F ₁₆	0694 ₁₆ to 069F ₁₆
Block 2	1st character	0620 ₁₆	06A0 ₁₆
	2nd character	0621 ₁₆	06A1 ₁₆
	3rd character	0622 ₁₆	06A2 ₁₆
	:	:	:
	18nd character	0631 ₁₆	06B1 ₁₆
	19rd character	0632 ₁₆	06B2 ₁₆
	20th character	0633 ₁₆	06B3 ₁₆

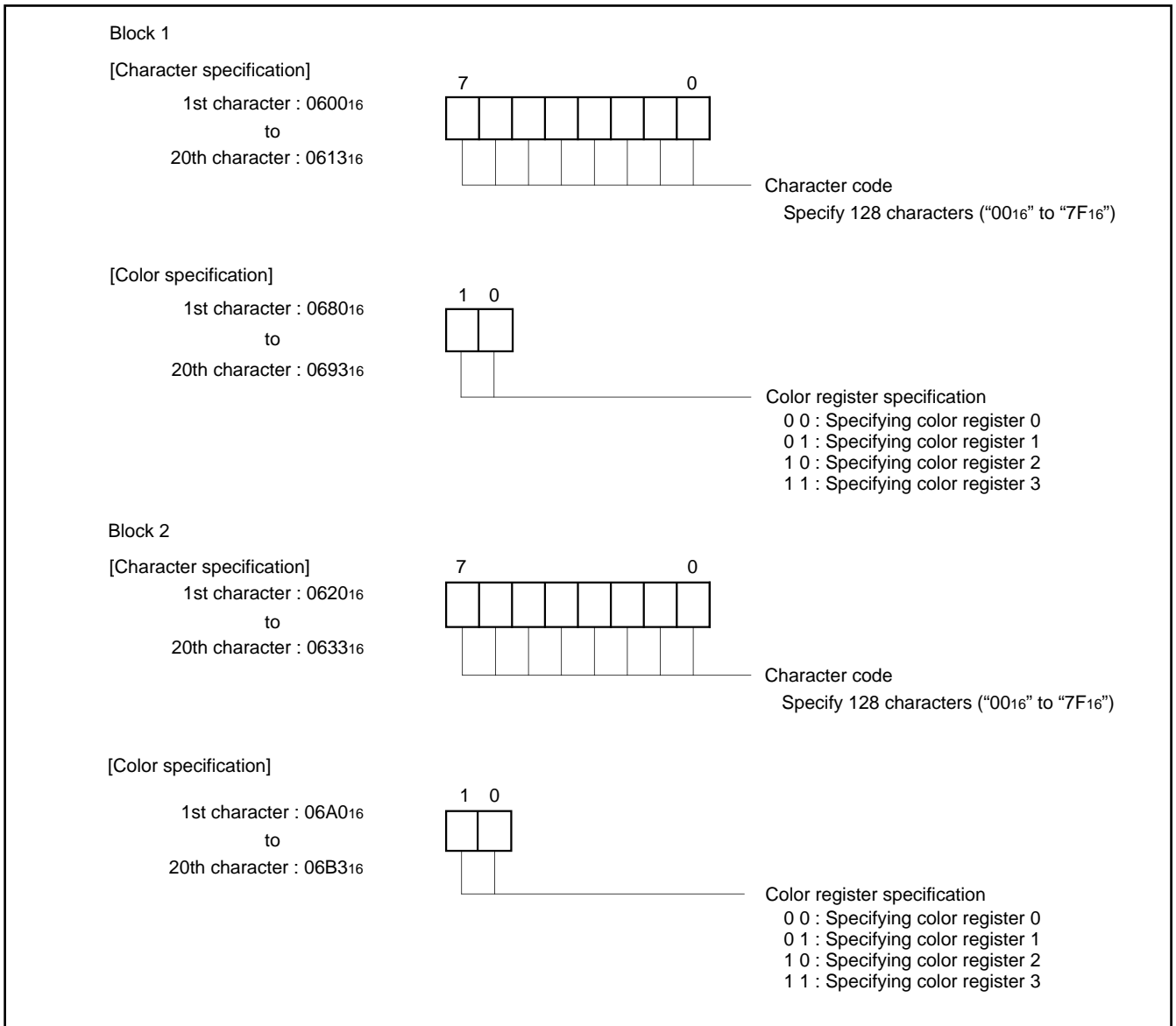

Fig. 33. Structure of CRT display RAM

(5) Color Registers

The color of a displayed character can be specified by setting the color to one of the 4 registers (CO0 to CO3: addresses 00E6₁₆ to 00E9₁₆) and then specifying that color register with the CRT display RAM. There are 3 color outputs; R, G and B. By using a combination of these outputs, it is possible to set 2^3-1 (when no output) = 7 colors. However, since only 4 color registers are available, up to 4 colors can be disabled at one time.

R, G and B outputs are set by using bits 1 to 3 in the color register. Bit 5 is used to specify whether a character output or blank output. Figure 34 shows the structure of the color register.

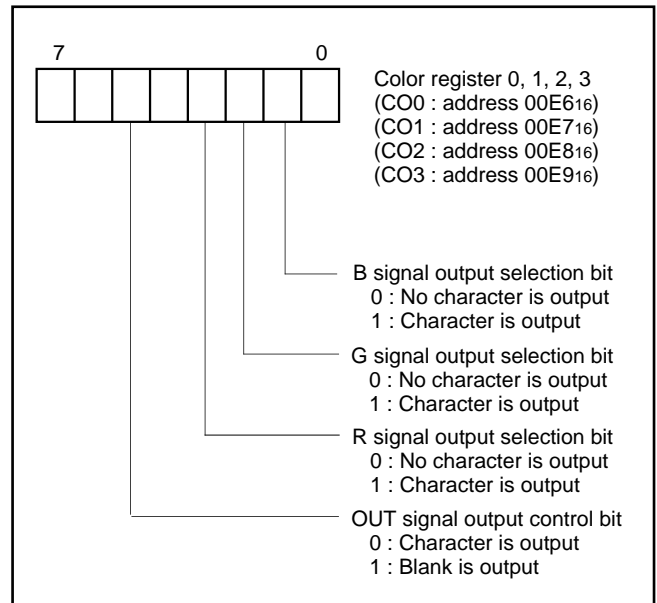

Fig. 34. Structure of color registers

(6) Character Border Function

An border of 1 clock (1 dot) equivalent size can be added to a character to be displayed in both horizontal and vertical directions. The border is output from the OUT pin. In this case, set bit 5 of a color register to "0" (character is output).

Border can be specified in units of block by using the border selection register (address 00E516). Figure 35 shows the structure of the border selection register. Table 9 shows the relationship between the values set in the border selection register and the character border function.

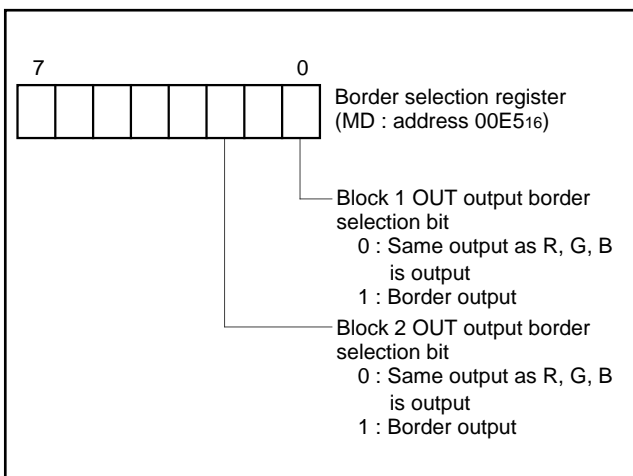

Fig. 35. Structure of border selection register

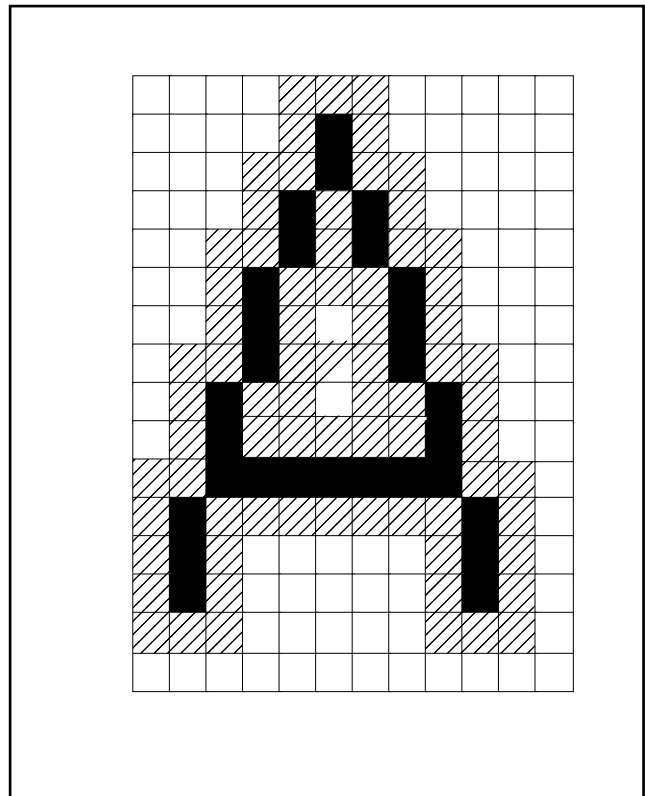

Fig. 36. Example of border

Table 9. Relationship between set value in border selection register and character border function

Border selection register MDn0	Functions	Example of output
0	Ordinary	R, G, B output OUT output
1	Border including character	R, G, B output OUT output

(7) Multiline Display

The M37220M3-XXXSP can ordinarily display 2 lines on the CRT screen by displaying 2 blocks at different vertical positions. In addition, it can display up to 16 lines by using CRT interrupts.

A CRT interrupt request occurs at the point at which display of each block has been completed. In other words, when a scanning line reaches the point of the display position (specified by the vertical position registers) of a certain block, the character display of that block starts, and an interrupt occurs at the point at which the scanning line exceeds the block.

Note: A CRT interrupt does not occur at the end of display when the block is not displayed. In other words, if a block is set to off display with the display control bit of the CRT control register (address 00EA16), a CRT interrupt request does not occur (refer to Figure 37).

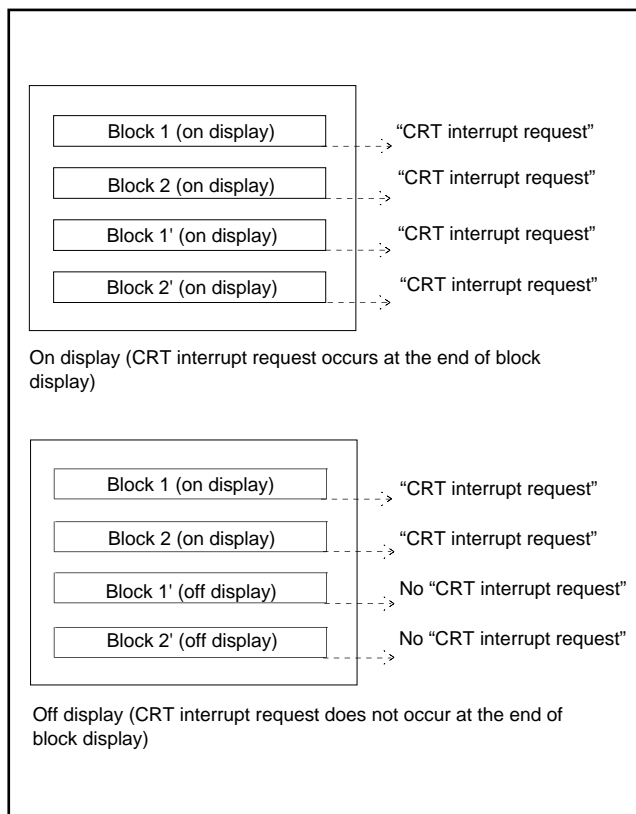

Fig. 37. Timing of CRT interrupt request

(8) CRT Output Pin Control

The CRT output pins R, G, B, and OUT can also function as ports P52, P53, P54 and P55. Set the corresponding bit of the port P5 direction register (address 00CB16) to "0" to specify these pins as CRT output pins, or set it to "1" to specify it as a general-purpose port P5 pins.

The input polarity of signals HSYNC and VSYNC and output polarity of signals R, G, B, and OUT can be specified with the bits of the CRT port control register (address 00EC16) . Set a bit to "0" to specify positive polarity; set it to "1" to specify negative polarity. The structure of the CRT port control register is shown in Figure 38.

(9) Raster Coloring Function

An entire screen (raster) can be colored by setting the bits 5 to 7 of the CRT port control register. Since each of the R, G, and B pins can be switched to raster coloring output, 7 raster colors can be obtained. If the R, G, and B pins have been set to MUTE signal output, a raster coloring signal is output in the part except a no-raster colored character (in Figure 39, a character "O") during 1 horizontal scanning period. This ensures that character colors do not mix with the raster color. In this case, MUTE signal is output from the OUT pin.

An example in which a magenta character "I" and a red character "O" are displayed with blue raster coloring is shown in Figure 39.

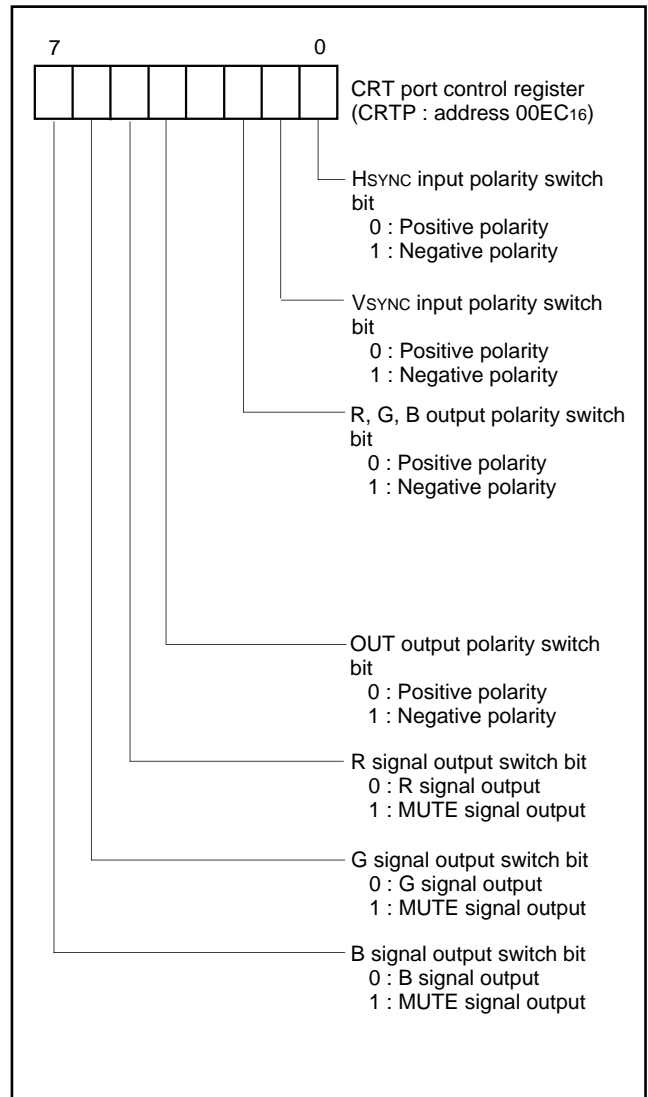

Fig. 38. Structure of CRT port control register

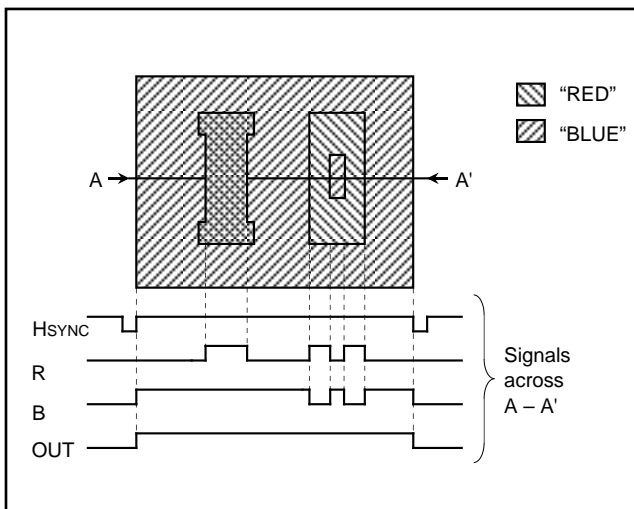

Fig. 39. Example of raster coloring

(10) Clock for Display

As a clock for display to be used for CRT display, it is possible to select one of the following 4 types.

- Main clock supplied from the XIN pin
- Main clock supplied from the XIN pin divided by 1.5
- Clock from the LC or RC supplied from the pins OSC1 and OSC2.
- Clock from the ceramic resonator or quartz-crystal oscillator supplied from the pins OSC1 and OSC2.

This clock for display can be selected for each block by the CRT clock selection register (address 00ED₁₆).

When selecting the main clock, set the oscillation frequency to 8 MHz.

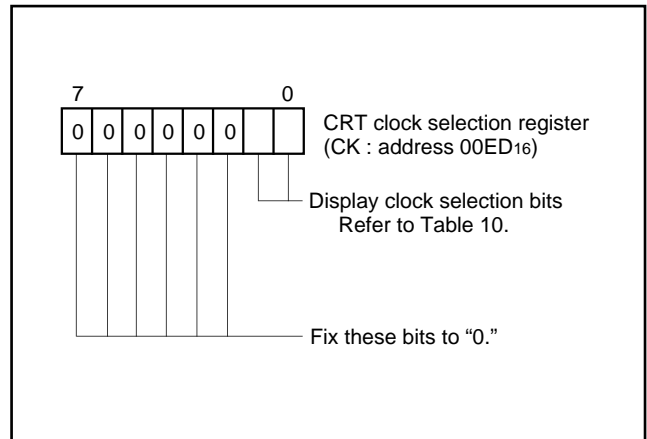

Fig. 40. Structure of CRT clock selection register

Table 10. Set value of CRT clock selection register and clock for display

b1	b0	Functions	
0	0	The clock for display is supplied by connecting RC or LC across the pins OSC1 and OSC2.	
0	1	Since the main clock is used as the clock for display, the oscillation frequency is limited. Because of this, the character size in width (horizontal) direction is also limited. In this case, pins OSC1 and OSC2 are also used as input ports P33 and P34 respectively.	CRT oscillation frequency = $f(XIN)$
1	0		CRT oscillation frequency = $f(XIN)/1.5$
1	1	The clock for display is supplied by connecting the following across the pins OSC1 and OSC2. <ul style="list-style-type: none"> • a ceramic resonator only for CRT display and a feedback resistor • a quartz-crystal oscillator only for CRT display and a feedback resistor (Note) 	

Note: It is necessary to connect other ceramic resonator or quartz-crystal oscillator across the pins XIN and XOUT.

RESET CIRCUIT

The M37220M3-XXXSP is reset according to the sequence shown in Figure 41. It starts the program from the address formed by using the content of address FFFF₁₆ as the high-order address and the content of the address FFFE₁₆ as the low-order address, when the RESET pin is held at "L" level for 2 μs or more while the power source voltage is 5 V ± 10 % and the oscillation of a quartz-crystal oscillator

or a ceramic resonator is stable and then returned to "H" level. The internal state of microcomputer at reset are shown in Figure 43. An example of the reset circuit is shown in Figure 42. The reset input voltage must be kept 0.6 V or less until the power source voltage surpasses 4.5 V.

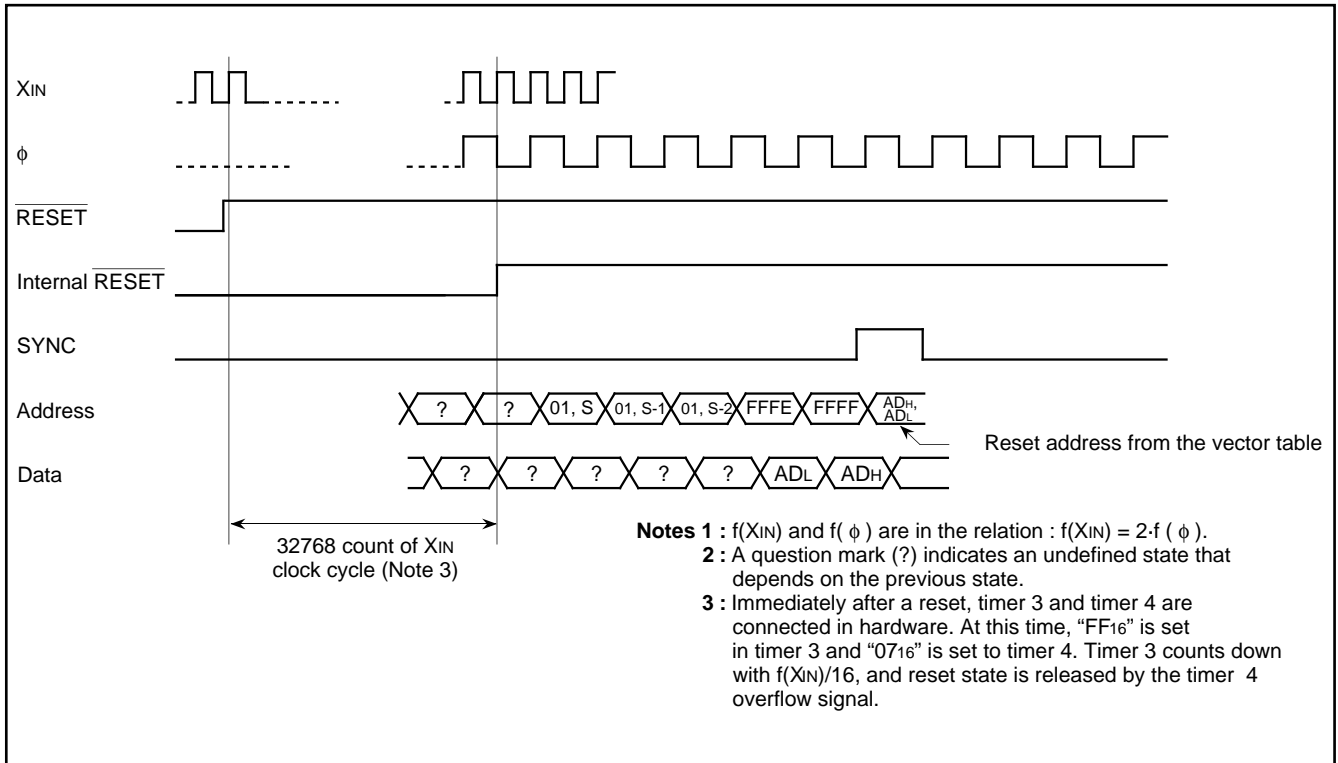

Fig. 41. Reset sequence

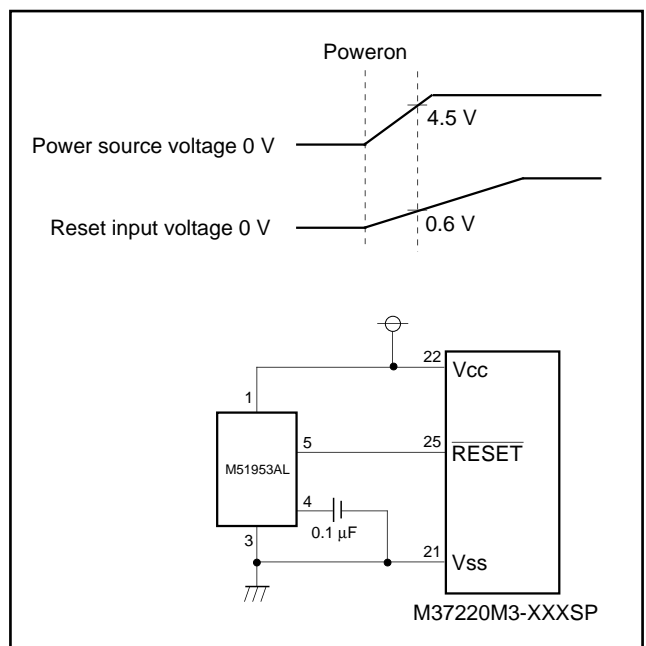

Fig. 42. Example of reset circuit

SINGLE-CHIP 8-BIT CMOS MICROCOMPUTER for VOLTAGE SYNTHESIZER
with ON-SCREEN DISPLAY CONTROLLER

	Address	Contents of register		Address	Contents of register
Port P0 direction register	(00C1 ₁₆)	00 ₁₆	CRT control register	(00EA ₁₆)	XXXXXXXX0000
Port P1 direction register	(00C3 ₁₆)	00 ₁₆	CRT port control register	(00EC ₁₆)	0000XXXX0000
Port P2 direction register	(00C5 ₁₆)	00 ₁₆	CRT clock selection register	(00ED ₁₆)	XXXXXXXXXX00
Port P3 direction register	(00C7 ₁₆)	XXXXXXXX0000	A-D control register 1	(00EE ₁₆)	XXXX*XX000
Port P5	(00CA ₁₆)	XXXX*****X	A-D control register 2	(00EF ₁₆)	XX00000000
Port P5 direction register	(00CB ₁₆)	XX0000XX	Timer 1	(00F0 ₁₆)	FF ₁₆
Port P3 output mode control register	(00CD ₁₆)	XXXXXXXX0000	Timer 2	(00F1 ₁₆)	07 ₁₆
DA-L register	(00CF ₁₆)	XXXX*****X	Timer 3	(00F2 ₁₆)	FF ₁₆
PWM output control register 1	(00D5 ₁₆)	00 ₁₆	Timer 4	(00F3 ₁₆)	07 ₁₆
PWM output control register 2	(00D6 ₁₆)	XXXX0000XX	Timer 12 mode register	(00F4 ₁₆)	XXXX000000
Serial I/O mode register	(00DC ₁₆)	X00XXXX000	Timer 34 mode register	(00F5 ₁₆)	XX00000000
DA1 conversion register	(00DE ₁₆)	XXXX*****X	Interrupt input polarity register	(00F9 ₁₆)	XX000XXXXX
DA2 conversion register	(00DF ₁₆)	XXXX*****X	CPU mode register	(00FB ₁₆)	XXXXXXXX1XXX
Horizontal register	(00E0 ₁₆)	XX00000000	Interrupt request register 1	(00FC ₁₆)	0XXXX00000
Vertical position register 1	(00E1 ₁₆)	X*****X	Interrupt request register 2	(00FD ₁₆)	XXXX0XXXX0
Vertical position register 2	(00E2 ₁₆)	X*****X	Interrupt control register 1	(00FE ₁₆)	0XXXX00000
Character size register	(00E4 ₁₆)	XXXXX*****	Interrupt control register 2	(00FF ₁₆)	XXXX0XXXX0
Border selection register	(00E5 ₁₆)	XXXXXX*XX*	Processor status register	(PS)	*****1***
Color register 0	(00E6 ₁₆)	XX0XX000XX	Program counter	(PC _H)	Contents of addressFFFF ₁₆
Color register 1	(00E7 ₁₆)	XX0XX000XX		(PC _L)	Contents of addressFFFE ₁₆
Color register 2	(00E8 ₁₆)	XX0XX000XX			
Color register 3	(00E9 ₁₆)	XX0XX000XX			

Note : The contents of all other registers and RAM are undefined at reset, so their initial values.

* : Undefined
X : Unused bit

Fig. 43. Internal state of microcomputer at reset

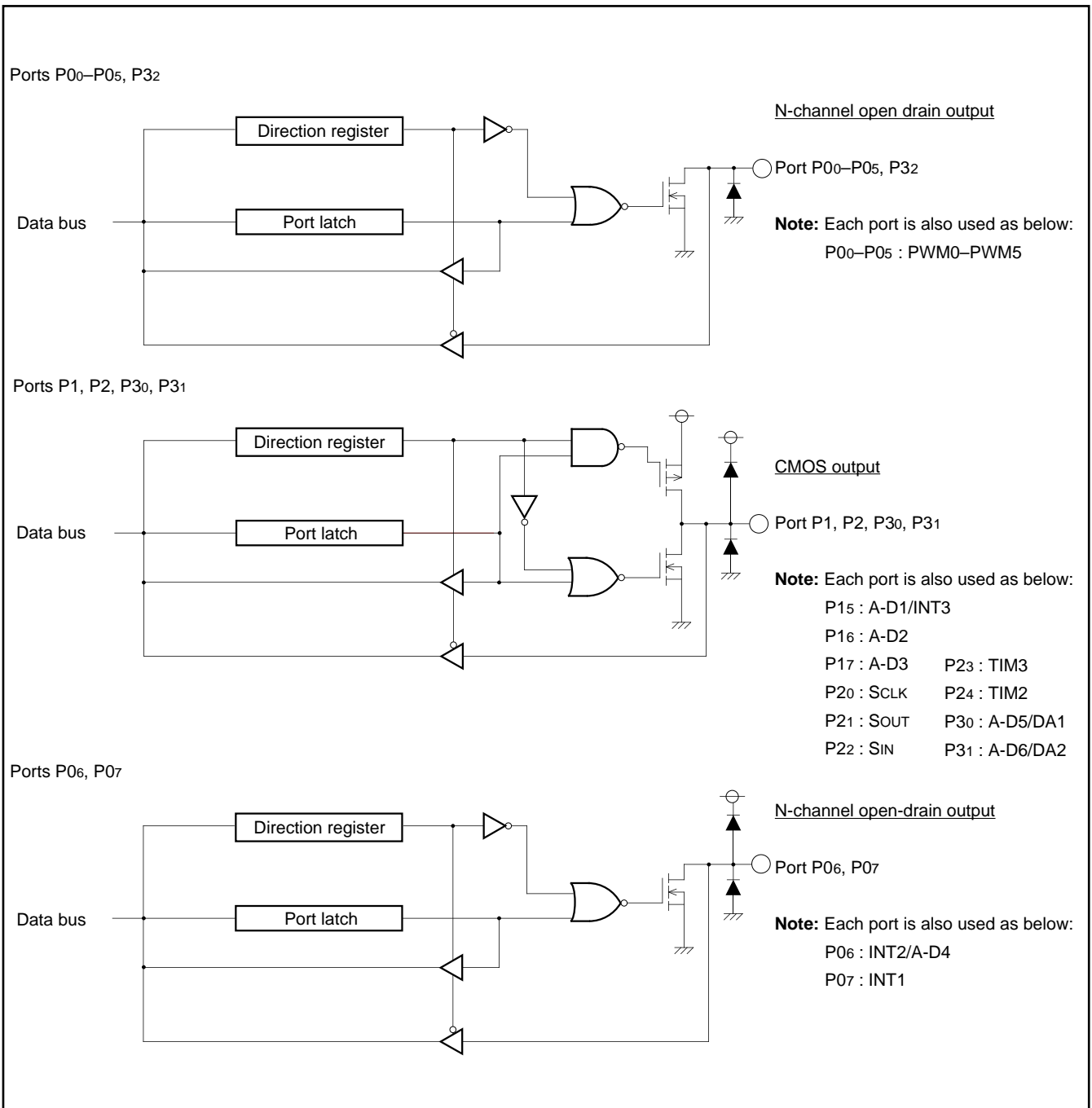

Fig. 44. I/O pin block diagram (1)

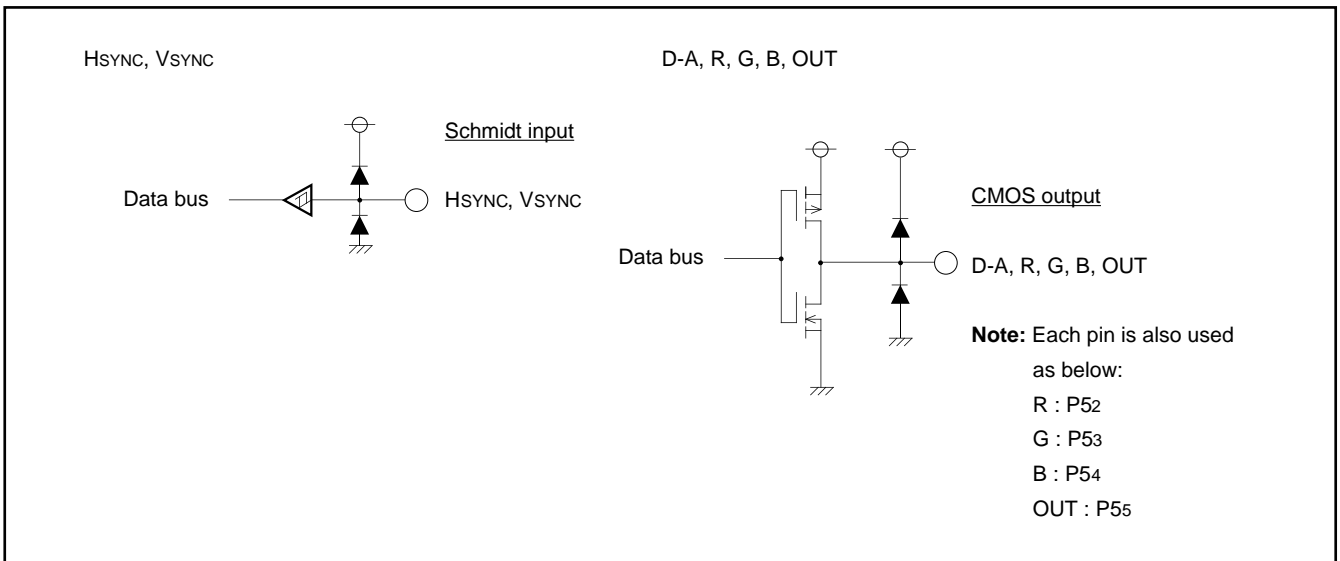

Fig. 45. I/O pin block diagram (2)

M37220M3-XXXSP

SINGLE-CHIP 8-BIT CMOS MICROCOMPUTER for VOLTAGE SYNTHESIZER
with ON-SCREEN DISPLAY CONTROLLER

CLOCK GENERATING CIRCUIT

The built-in clock generating circuit is shown in Figure 48. When the STP instruction is executed, the internal clock stops at "H" level. At the same time, timers 3 and 4 are connected in hardware and "FF16" is set in the timer 3, "0716" is set in the timer 4. Select $f(X_{IN})/16$ as the timer 3 count source (set bit 0 of the timer 34 mode register to "0" before the execution of the STP instruction). And besides, set the timer 3 and timer 4 interrupt enable bits to disabled ("0") before execution of the STP instruction). The oscillator restarts when external interrupt is accepted, however, the internal clock keeps its "H" level until timer 4 overflows. Because this allows time for oscillation stabilizing when a ceramic resonator or a quartz-crystal oscillator is used. When the WIT instruction is executed, the internal clock stops in the "H" level but the oscillator continues running. This wait state is released when an interrupt is accepted (Note). Since the oscillator does not stop, the next instruction can be executed at once. When returning from the stop or the wait state, to accept an interrupt, set the corresponding interrupt enable bit to "1" before executing the STP or the WIT instructions.

Note: In the wait mode, the following interrupts are invalid.

- (1) VSYNC interrupt
- (2) CRT interrupt
- (3) $f(X_{IN})/4096$ interrupt
- (4) Timer 1 interrupt using $f(X_{IN})/4096$ as count source
- (5) Timer 2 interrupt using P24/TIM2 pin input as count source
- (6) Timer 3 interrupt using P23/TIM3 pin input as count source
- (7) Timer 4 interrupt using $f(X_{IN})/2$ as count source
- (8) Multi-master I²C-BUS interface interrupt

The circuit example using a ceramic resonator (or a quartz-crystal oscillator) is shown in Figure 46. Use the circuit constants in accordance with the resonator manufacture's recommended values. The circuit example with external clock input is shown in Figure 47. Input the clock to the X_{IN} pin, and open the X_{OUT} pin.

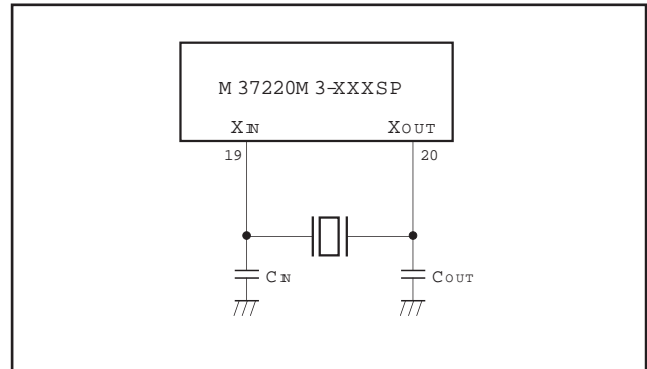

Fig. 46. Ceramic resonator circuit example

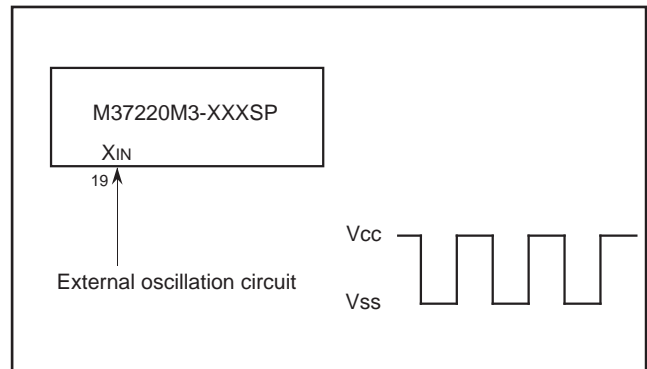

Fig. 47. External clock input circuit example

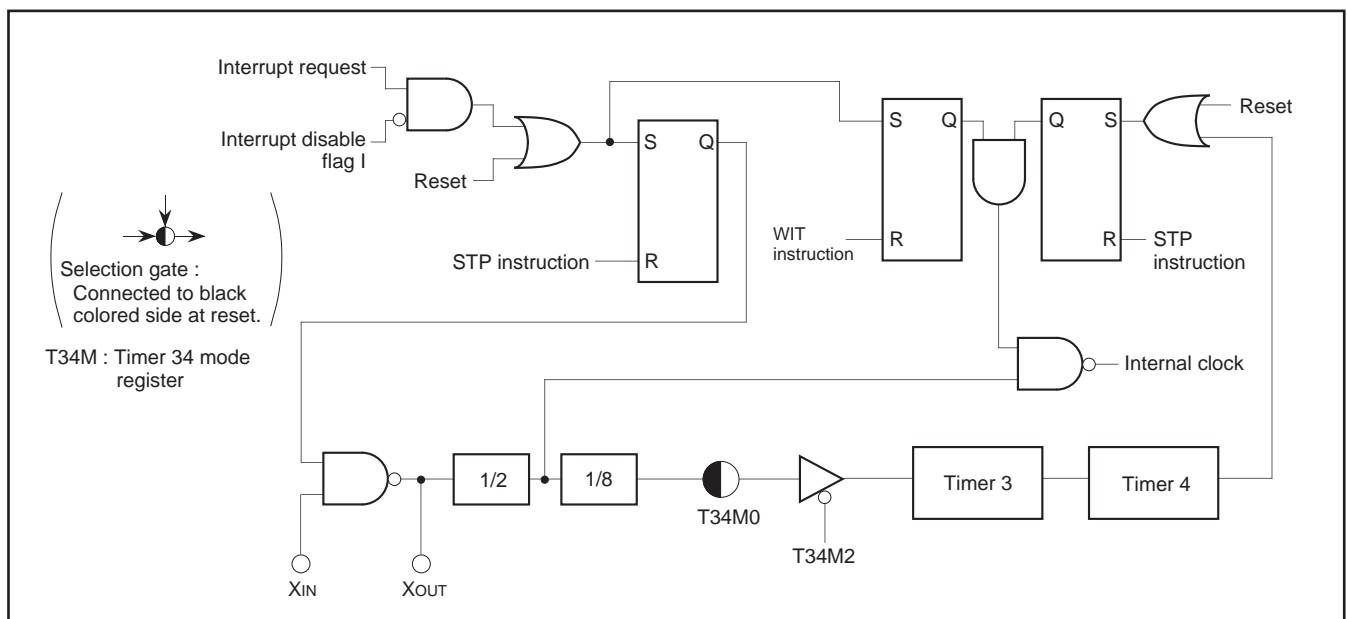

Fig. 48. Clock generating circuit block diagram

DISPLAY OSCILLATION CIRCUIT

The CRT display clock oscillation circuit has a built-in clock oscillation circuits, so that a clock for display can be obtained simply by connecting an LC, an RC, a ceramic resonator or a quartz-crystal oscillator circuit across the pins OSC 1 and OSC 2. Select the clock for display with bits 0 and 1 of the CRT clock selection register (address 00ED16).

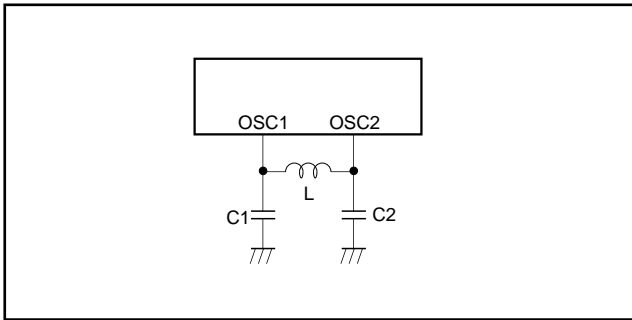

Fig. 49. Display oscillation circuit

AUTO-CLEAR CIRCUIT

When power source is supplied, the auto-clear function can be performed by connecting the following circuit to the RESET pin.

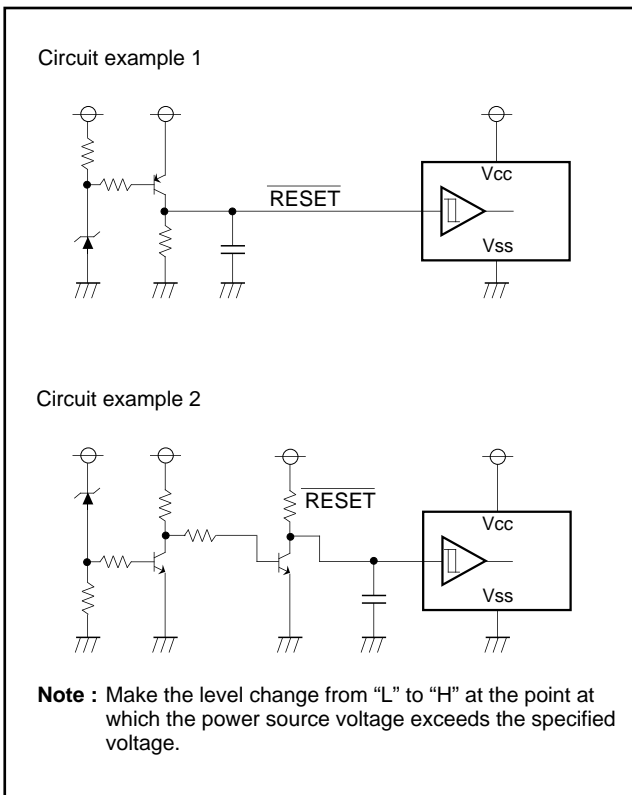

Fig. 50. Auto-clear circuit example

ADDRESSING MODE

The memory access is reinforced with 17 kinds of addressing modes. Refer to the SERIES 740 <Software> User's Manual for details.

MACHINE INSTRUCTIONS

There are 71 machine instructions. Refer to the SERIES 740 <Software> User's Manual for details.

PROGRAMMING NOTES

- (1) The divide ratio of the timer is $1/(n+1)$.
- (2) Even though the BBC and BBS instructions are executed immediately after the interrupt request bits are modified (by the program), those instructions are only valid for the contents before the modification. At least one instruction cycle (such as an NOP) between the modification of the interrupt request bits and the execution of the BBC and BBS instructions.
- (3) After the ADC and SBC instructions are executed (in decimal mode), one instruction cycle (such as an NOP) is needed before the SEC, CLC, or CLD instruction is executed.
- (4) An NOP instruction is needed immediately after the execution of a PLP instruction.
- (5) In order to avoid noise and latch-up, connect a bypass capacitor ($\approx 0.1 \mu\text{F}$) directly between the Vcc pin-Vss pin and the Vcc pin-CNvss pin using a thick wire.

DATA REQUIRED FOR MASK ORDERS

The following are necessary when ordering a mask ROM production:

- (1) Mask ROM Order Confirmation Form
- (2) Mask Specification Form
- (3) Data to be written to ROM, in EPROM form (32-pin DIP type 27C101, three identical copies)

SINGLE-CHIP 8-BIT CMOS MICROCOMPUTER for VOLTAGE SYNTHESIZER
with ON-SCREEN DISPLAY CONTROLLER

ABSOLUTE MAXIMUM RATINGS

Symbol	Parameter	Conditions	Ratings	Unit
VCC	Power source voltage VCC	All voltages are based on Vss. Output transistors are cut off.	-0.3 to 6	V
VI	Input voltage CNVss		-0.3 to 6	V
VI	Input voltage P00-P07,P10-P17, P20-P27, P30-P34, OSC1, XIN, HSYNC, VSYNC, RESET		-0.3 to VCC + 0.3	V
VO	Output voltage P06, P07, P10-P17, P20-P27, P30-P32, R, G, B, OUT, D-A, XOUT, OSC2		-0.3 to VCC + 0.3	V
VO	Output voltage P00-P05		-0.3 to 13	V
IOH	Circuit current R, G, B, OUT, P10-P17, P20-P27, P30, P31, D-A		0 to 1 (Note 1)	mA
IOL1	Circuit current R, G, B, OUT, P06, P07, P10-P17, P20-P23, P30-P32, D-A		0 to 2 (Note 2)	mA
IOL2	Circuit current P00-P05		0 to 1 (Note 2)	mA
IOL3	Circuit current P24-P27		0 to 10 (Note 3)	mA
Pd	Power dissipation	Ta = 25 °C	550	mW
Topr	Operating temperature		-10 to 70	°C
Tstg	Storage temperature		-40 to 125	°C

RECOMMENDED OPERATING CONDITIONS (Ta = -10 °C to 70 °C, VCC = 5 V ± 10 %, unless otherwise noted)

Symbol	Parameter	Limits			Unit
		Min.	Typ.	Max.	
VCC	Power source voltage (Note 4), During CPU, CRT operation	4.5	5.0	5.5	V
VSS	Power source voltage	0	0	0	V
VIH1	"H" input voltage P00-P07,P10-P17, P20-P27, P30-P34, SIN, SCLK, HSYNC, VSYNC, RESET, XIN, OSC1, TIM2, TIM3, INT1, INT2, INT3	0.8VCC		VCC	V
VIL1	"L" input voltage P00-P07,P10-P17, P20-P27, P30-P34	0		0.4 VCC	V
VIL2	"L" input voltage HSYNC, VSYNC, RESET, TIM2, TIM3, INT1, INT2, INT3, XIN, OSC1, SIN, SCLK	0		0.2 VCC	V
IOH	"H" average output current (Note 1) R, G, B, OUT, D-A, P10-P17, P20-P27, P30, P31			1	mA
IOL1	"L" average output current (Note 2) R, G, B, OUT, D-A, P06, P07, P10-P17, P20-P27, P30-P32			2	mA
IOL2	"L" average output current (Note 2) P00-P05			1	mA
IOL3	"L" average output current (Note 3) P24-P27			10	mA
fCPU	Oscillation frequency (for CPU operation) (Note 5) XIN	7.9	8.0	8.1	MHz
fCRT	Oscillation frequency (for CRT display) (Note 5) OSC1	5.0		8.0	MHz
fhs1	Input frequency TIM2, TIM3			100	kHz
fhs2	Input frequency SCLK			1	MHz

- Notes 1:** The total current that flows out of the IC must be 20 mA (max.).
2: The total input current to IC (IOL1 + IOL2) must be 30 mA or less.
3: The total average input current for ports P24-P27 to IC must be 20 mA or less.
4: Connect 0.1µF or more capacitor externally across the power source pins VCC-VSS so as to reduce power source noise. Also connect 0.1µF or more capacitor externally across the pins VCC-CNVSS.
5: Use a quartz-crystal oscillator or a ceramic resonator for the CPU oscillation circuit.

SINGLE-CHIP 8-BIT CMOS MICROCOMPUTER for VOLTAGE SYNTHESIZER
with ON-SCREEN DISPLAY CONTROLLER

ELECTRIC CHARACTERISTICS ($V_{CC} = 5\text{ V} \pm 10\%$, $V_{SS} = 0\text{ V}$, $f(X_{IN}) = 8\text{ MHz}$, $T_a = -10\text{ }^\circ\text{C}$ to $70\text{ }^\circ\text{C}$, unless otherwise noted)

Symbol	Parameter		Test conditions	Limits			Unit	
				Min.	Typ.	Max.		
ICC	Power source current	System operation	$V_{CC} = 5.5\text{ V}$, $f(X_{IN}) = 8\text{ MHz}$	CRT OFF		20	40	mA
		CRT ON			30	60		
		Stop mode	$V_{CC} = 5.5\text{ V}$, $f(X_{IN}) = 0$			300	μA	
VOH	"H" output voltage	R, G, B, OUT, D-A, P10–P17, P20–P27, P30, P31	$V_{CC} = 4.5\text{ V}$ $I_{OH} = -0.5\text{ mA}$	2.4			V	
VOL	"L" output voltage	R, G, B, OUT, D-A, P00–P07, P10–P17, P20–P23, P30–P32	$V_{CC} = 4.5\text{ V}$ $I_{OL} = 0.5\text{ mA}$			0.4	V	
	"L" output voltage	P24–P27	$V_{CC} = 4.5\text{ V}$ $I_{OL} = 10.0\text{ mA}$			3.0		
VT+–VT–	Hysteresis	RESET	$V_{CC} = 5.0\text{ V}$		0.5	0.7	V	
	Hysteresis (Note)	HSYNC, VSYNC, TIM2, TIM3, INT1, INT2, INT3, SIN, SCLK	$V_{CC} = 5.0\text{ V}$		0.5	1.3		
IIZH	"H" input leak current	RESET, P00–P07, P10–P17, P20–P27, P30–P34, HSYNC, VSYNC	$V_{CC} = 5.5\text{ V}$ $V_I = 5.5\text{ V}$			5	μA	
IIZL	"L" input leak current	RESET, P00–P07, P10–P17, P20–P27, P30–P34, HSYNC, VSYNC	$V_{CC} = 5.5\text{ V}$ $V_O = 0\text{ V}$			5	μA	
IOZH	"H" output leak current	P00–P05	$V_{CC} = 5.5\text{ V}$ $V_I = 12\text{ V}$			10	μA	

Note: P06, P07, P15, P23, P24 have the hysteresis when these pins are used as interrupt input pins or timer input pins. P20–P22 have the hysteresis when these pins are used as serial I/O pins.

A-D COMPARATOR CHARACTERISTICS

($V_{CC} = 5\text{ V} \pm 10\%$, $V_{SS} = 0\text{ V}$, $f(X_{IN}) = 8\text{ MHz}$, $T_a = -10\text{ }^\circ\text{C}$ to $70\text{ }^\circ\text{C}$, unless otherwise noted)

Symbol	Parameter	Test conditions	Limits			Unit
			Min.	Typ.	Max.	
—	Resolution				6	bits
—	Absolute accuracy		0	± 1	± 2	LSB

Note: When $V_{CC} = 5\text{ V}$, 1 LSB = 5/64 V.

D-A CONVERTER CHARACTERISTICS

($V_{CC} = 5\text{ V} \pm 10\%$, $V_{SS} = 0\text{ V}$, $f(X_{IN}) = 8\text{ MHz}$, $T_a = -10\text{ }^\circ\text{C}$ to $70\text{ }^\circ\text{C}$, unless otherwise noted)

Symbol	Parameter	Test conditions	Limits			Unit
			Min.	Typ.	Max.	
—	Resolution				6	bits
—	Absolute accuracy				2	%
tsu	Setting time				3	μs
RO	Output resistor		1	2.5	4	$\text{k}\Omega$

M37220M3-XXXSP

SINGLE-CHIP 8-BIT CMOS MICROCOMPUTER for VOLTAGE SYNTHESIZER
with ON-SCREEN DISPLAY CONTROLLER

PACKAGE OUTLINE

42P4B

Plastic 42pin 600mil SDIP

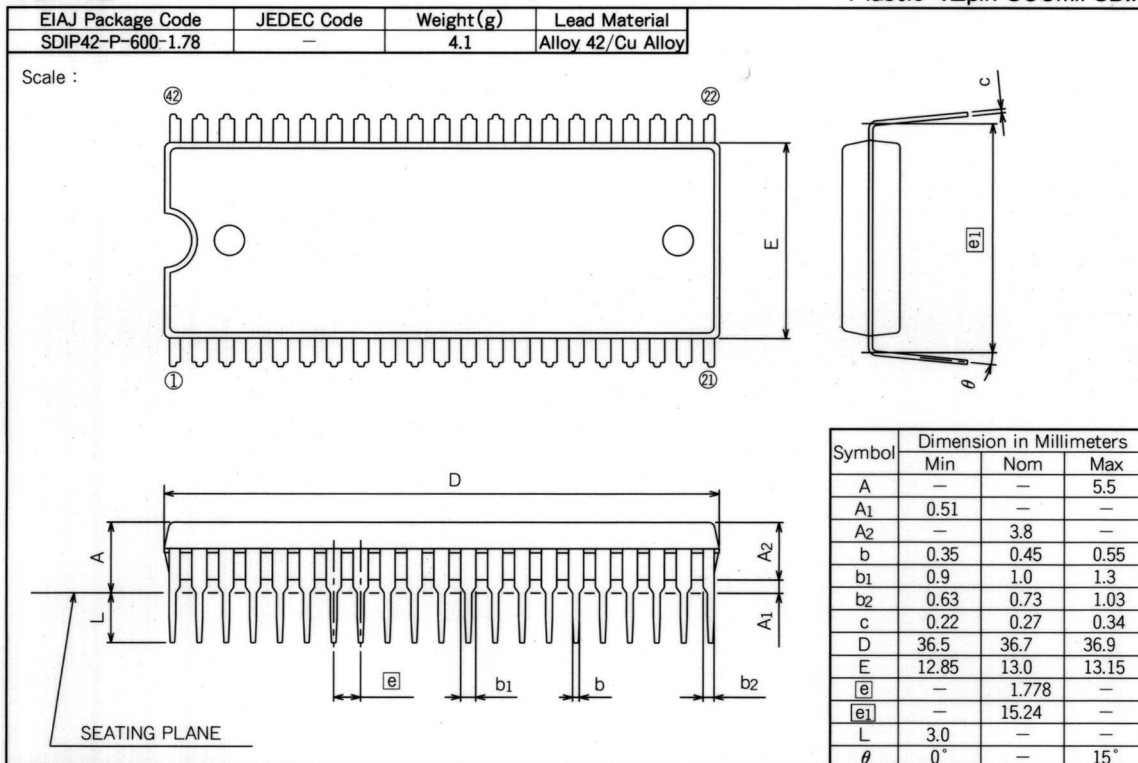

M37220M3-XXXSP

SINGLE-CHIP 8-BIT CMOS MICROCOMPUTER for VOLTAGE SYNTHESIZER
with ON-SCREEN DISPLAY CONTROLLER

GZZ-SH09-72B < 56A0 >

740 FAMILY MASK ROM CONFIRMATION FORM SINGLE-CHIP MICROCOMPUTER M37220M3-XXXSP MITSUBISHI ELECTRIC

Mask ROM number	
-----------------	--

Receipt	Date :	
	Section head signature	Supervisor signature

Note : Please fill in all items marked *.

* Customer	Company name	TEL ()	Issuance signature	Submitted by	Supervisor
	Date issued	Date :			

* 1. Confirmation

Specify the name of the product being ordered and the type of EPROMs submitted.

Three EPROMs are required for each pattern.

If at least two of the three sets of EPROMs submitted contain identical data, we will produce masks based on this data. We shall assume the responsibility for errors only if the mask ROM data on the products we produce differs from this data. Thus, extreme care must be taken to verify the data in the submitted EPROMs.

Checksum code for entire EPROM

--	--	--	--

 (hexadecimal notation)

EPROM type (indicate the type used)

<input type="checkbox"/> 27C101																						
<table border="1" style="width: 100%; border-collapse: collapse;"> <tr> <th colspan="2" style="text-align: left; padding: 2px;">EPROM address</th> </tr> <tr> <td style="padding: 2px;">0000₁₆</td> <td style="padding: 2px;">Product name ASCII code : 'M37220M3-'</td> </tr> <tr> <td style="padding: 2px;">000F₁₆</td> <td style="padding: 2px; background-color: #cccccc;"></td> </tr> <tr> <td style="padding: 2px;">D000₁₆</td> <td style="padding: 2px;">data</td> </tr> <tr> <td style="padding: 2px;">FFFF₁₆</td> <td style="padding: 2px;">ROM 12K bytes</td> </tr> <tr> <td style="padding: 2px;">10000₁₆</td> <td style="padding: 2px;">Character ROM 1</td> </tr> <tr> <td style="padding: 2px;">107FF₁₆</td> <td style="padding: 2px;">Character ROM 2</td> </tr> <tr> <td style="padding: 2px;">10800₁₆</td> <td style="padding: 2px;"></td> </tr> <tr> <td style="padding: 2px;">10FFF₁₆</td> <td style="padding: 2px; background-color: #cccccc;"></td> </tr> <tr> <td style="padding: 2px;">11000₁₆</td> <td style="padding: 2px;"></td> </tr> <tr> <td style="padding: 2px;">1FFFF₁₆</td> <td style="padding: 2px;"></td> </tr> </table>	EPROM address		0000 ₁₆	Product name ASCII code : 'M37220M3-'	000F ₁₆		D000 ₁₆	data	FFFF ₁₆	ROM 12K bytes	10000 ₁₆	Character ROM 1	107FF ₁₆	Character ROM 2	10800 ₁₆		10FFF ₁₆		11000 ₁₆		1FFFF ₁₆	
EPROM address																						
0000 ₁₆	Product name ASCII code : 'M37220M3-'																					
000F ₁₆																						
D000 ₁₆	data																					
FFFF ₁₆	ROM 12K bytes																					
10000 ₁₆	Character ROM 1																					
107FF ₁₆	Character ROM 2																					
10800 ₁₆																						
10FFF ₁₆																						
11000 ₁₆																						
1FFFF ₁₆																						

- (1) Set "FF₁₆" in the shaded area.
- (2) Write the ASCII codes that indicates the product name of "M37220M3-" to addresses 0000₁₆ to 000F₁₆.

EPROM data check item (Refer the EPROM data and check "✓" in the appropriate box)

- Do you set "FF₁₆" in the shaded area ? → Yes
- Do you write the ASCII codes that indicates the product name of "M37220M3-" to addresses 0000₁₆ to 000F₁₆ ? → Yes

* 2. Mark specification

Mark specification must be submitted using the correct form for the type package being ordered fill out the appropriate mark specification form (42P4B for M37220M3-XXXSP) and attach to the mask ROM confirmation form.

* 3. Comments

GZZ-SH09-72B <56A0 >

**740 FAMILY MASK ROM CONFIRMATION FORM
SINGLE-CHIP MICROCOMPUTER M37220M3-XXXSP
MITSUBISHI ELECTRIC**

Writing the product name and character ROM data onto EPROMs

Addresses 0000₁₆ to 000F₁₆ store the product name, and addresses 10000₁₆ to 10FFF₁₆ store the character pattern. If the name of the product contained in the EPROMs does not match the name on the mask ROM confirmation form, the ROM processing is disabled. Write the data correctly.

1. Inputting the name of the product with the ASCII code
ASCII codes 'M37220M3-' are listed on the right.
The addresses and data are in hexadecimal notation.

Address		Address	
0000 ₁₆	'M' = 4 D ₁₆	0008 ₁₆	'-' = 2 D ₁₆
0001 ₁₆	'3' = 3 3 ₁₆	0009 ₁₆	FF ₁₆
0002 ₁₆	'7' = 3 7 ₁₆	000A ₁₆	FF ₁₆
0003 ₁₆	'2' = 3 2 ₁₆	000B ₁₆	FF ₁₆
0004 ₁₆	'2' = 3 2 ₁₆	000C ₁₆	FF ₁₆
0005 ₁₆	'0' = 3 0 ₁₆	000D ₁₆	FF ₁₆
0006 ₁₆	'M' = 4 D ₁₆	000E ₁₆	FF ₁₆
0007 ₁₆	'3' = 3 3 ₁₆	000F ₁₆	FF ₁₆

2. Inputting the character ROM
Input the character ROM data by dividing it into character ROM1 and character ROM2. For the character ROM data, see the next page and on.

GZZ-SH09-72B< 56A0 >

740 FAMILY MASK ROM CONFIRMATION FORM
SINGLE-CHIP MICROCOMPUTER M37220M3-XXXSP
MITSUBISHI ELECTRIC

The structure of character ROM (divided of 12X16 dots font)

Example

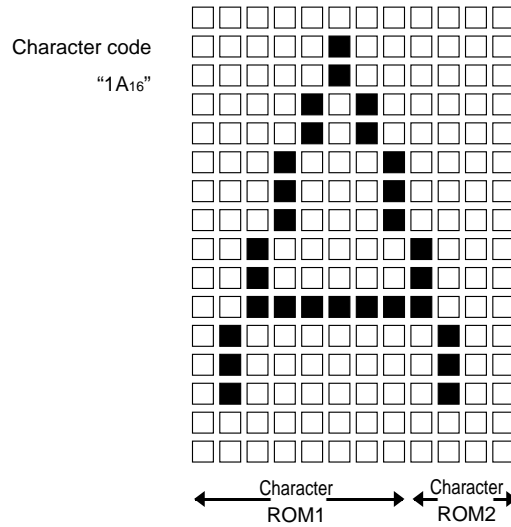

Example 101A0₁₆ to 101AF₁₆

	b7	b6	b5	b4	b3	b2	b1	b0	
0									00 ₁₆
1									04 ₁₆
2									04 ₁₆
3									0A ₁₆
4									0A ₁₆
5									11 ₁₆
6									11 ₁₆
7									11 ₁₆
8									20 ₁₆
9									20 ₁₆
A									3F ₁₆
B									40 ₁₆
C									40 ₁₆
D									40 ₁₆
E									00 ₁₆
F									00 ₁₆

Example 109A0₁₆ to 109AF₁₆

	b7	b6	b5	b4	b3	b2	b1	b0	
0									F0 ₁₆
1									F0 ₁₆
2									F0 ₁₆
3									F0 ₁₆
4									F0 ₁₆
5									F0 ₁₆
6									F0 ₁₆
7									F0 ₁₆
8									F8 ₁₆
9									F8 ₁₆
A									F8 ₁₆
B									F4 ₁₆
C									F4 ₁₆
D									F4 ₁₆
E									F0 ₁₆
F									F0 ₁₆

SINGLE-CHIP 8-BIT CMOS MICROCOMPUTER for VOLTAGE SYNTHESIZER
with ON-SCREEN DISPLAY CONTROLLER

42P4B (42-PIN SHRINK DIP) MARK SPECIFICATION FORM

Mitsubishi IC catalog name

Please choose one of the marking types below (A, B, C), and enter the Mitsubishi IC catalog name and the special mark (if needed).

A. Standard Mitsubishi Mark

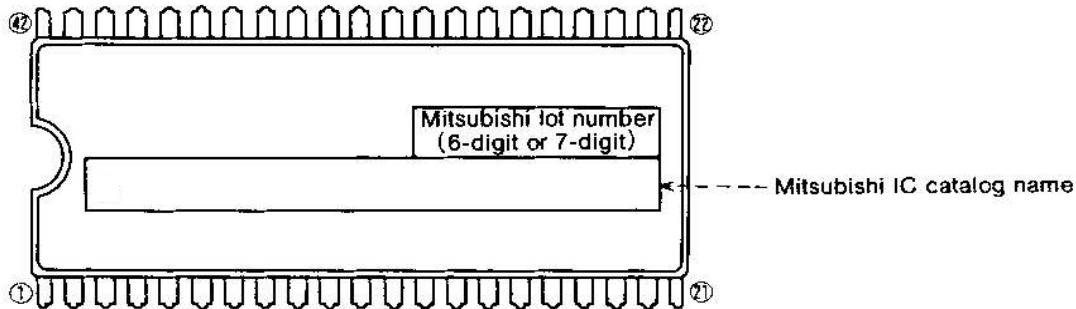

B. Customer's Parts Number + Mitsubishi Catalog Name

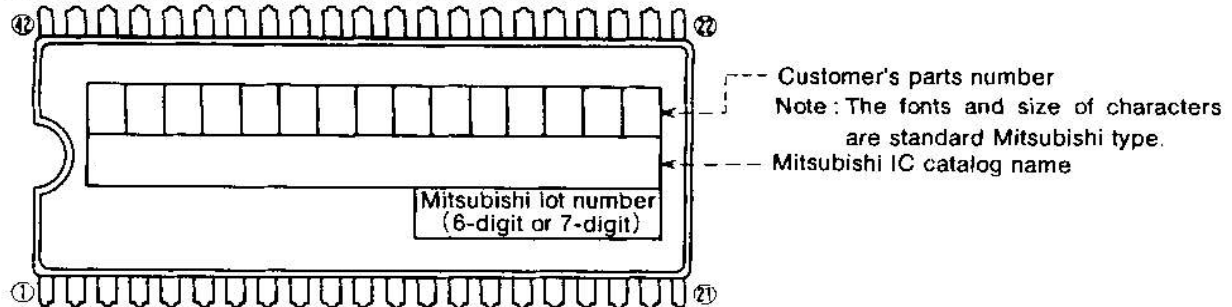

Note1: The mark field should be written right aligned.

2: The fonts and size of characters are standard Mitsubishi type.

3: Customer's parts number can be up to 15 characters:

Only 0~9, A~Z, +, -, /, (,), &, ©, . (period), and , (comma) are usable.

C. Special Mark Required

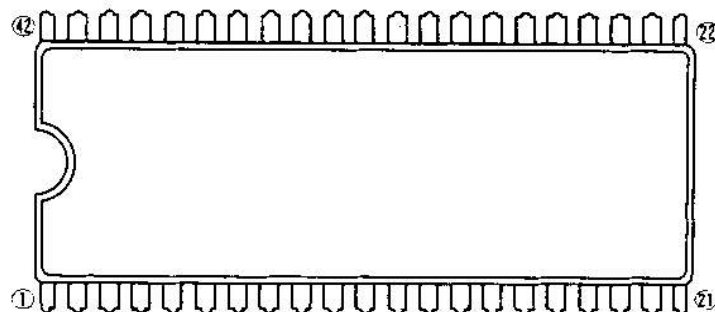

Note1: If the special mark is to be printed, indicate the desired layout of the mark in the upper figure. The layout will be duplicated as close as possible. Mitsubishi lot number (6-digit or 7-digit) and mask ROM number (3-digit) are always marked.

2: If the customer's trade mark logo must be used in the special mark, check the box below. Please submit a clean original of the logo.

For the new special character fonts a clean font original (ideally logo drawing) must be submitted.

Special logo required

The standard Mitsubishi font is used for all characters except for a logo.

MITSUBISHI DATA BOOK
SINGLE-CHIP 8-BIT MICROCOMPUTERS Vol.3

Sep. First Edition 1996 H-DF319-B

Edited by
Committee of editing of Mitsubishi Semiconductor Data Book

Published by
Mitsubishi Electric Corp., Semiconductor Division

This book, or parts thereof, may not be reproduced in any form without permission of Mitsubishi Electric Corporation.
©1996 MITSUBISHI ELECTRIC CORPORATION Printed in Japan

REVISION DESCRIPTION LIST

M37220M3-XXXSP DATA SHEET

Rev. No.	Revision Description	Rev. date
1.0	First Edition	9708
2.0	Information about copyright note, revision number, release data added (last page).	971130
2.1	Correct note (P43)	980731