

DA1469x

Multi-Core Bluetooth 5.2 SoC Family with System PMU

The DA1469x is a family of multi-core wireless microcontrollers, combining the latest Arm® Cortex®-M33 application processor with floating-point unit, advanced power management functionality, a cryptographic security engine, analog and digital peripherals, a dedicated sensor node controller, and a software configurable protocol engine with a radio that is compliant to the Bluetooth® 5.2 Low Energy standard.

The DA1469x is based on an Arm Cortex-M33 CPU with an 8-region MPU and a single-precision FPU offering up to 144 dMIPS. The dedicated application processor executes code from embedded memory (RAM) or external QSPI flash through a 16 kB 4-way associative cache controller, which is equipped with an on-the-fly decrypting capability without extra wait states. Bluetooth® 5.2 connectivity is guaranteed by a new software-configurable Bluetooth® Low Energy protocol engine (MAC) with an ultra-low-power radio transceiver, capable of +6 dBm output power and -97 dBm sensitivity offering a total link budget of 103 dB.

An optimized programmable sensor node controller allows sensor node operations and data acquisition without CPU intervention, achieving best-in-class power consumption.

The advanced power management unit of the DA1469x enables it to run on primary and secondary batteries, as well as provide power to external devices through the integrated SIMO DCDC and integrated LDOs. The on-chip JEITA-compliant hardware charger makes it possible to natively charge rechargeable batteries over USB.

A variety of standard and advanced peripherals enable interaction with other system components and the development of advanced user interfaces and feature-rich applications.

Key Features

- Compatible with Bluetooth® 5.2, ETSI EN 300 328 and EN 300 440 Class 2 (Europe), FCC CFR47 Part 15 (US) and ARIB STD-T66 (Japan)
- Flexible processing power
 - 32 kHz up to 96 MHz 32-bit Arm Cortex-M33 with 16 kB, 4-way associative cache and FPU
 - A flexible and configurable Bluetooth® LE MAC engine implementing the controller stack up to HCI
 - A sensor node controller running uCode for sensors manipulation
 - A uCode based motor controller for manipulating analog gear boxes for hands on watches
 - Optimized power modes (Extended sleep, Deep sleep, and Hibernation)
- Memories
 - 512 kB Data SRAM with retention capabilities
 - 4 kB One-Time-Programmable (OTP) memory
 - 16 kB Cache SRAM with retention capabilities
 - 128 kB ROM (including boot ROM and PKI routines for Flash image authentication)
- Power management
 - SIMO Buck DC-DC converter (2.4 V-4.75 V)
 - Four power supply pins for external devices, alive while DA1469x is asleep
- Supports Li-Polymer, Li-Ion, coin cells, NiMH and alkaline batteries
- Hardware charger (up to 5.0 V) with programmable curves and JEITA support
- Programmable thresholds for brownout detection
- Digital controlled oscillators
 - 32 MHz crystal (± 20 ppm max) and RC oscillator
 - 32 kHz crystal (± 50 ppm, ± 500 ppm max) and RCX oscillator
- Application cryptographic engine with AES-256, SHA-1, SHA-256, SHA-512 and a FIPS 140-2-compliant True Random Number Generator (TRNG)
- A Real Time Clock with 10 ms resolution
- 4 General purpose, 24-bit up/down timers with PWM
- Digital interfaces
 - Up to 55 General Purpose I/Os
 - Decrypt-on-the-fly QSPI FLASH interface
 - Separate QSPI PSRAM interface
 - Parallel/SPI LCD Controller with own DMA
 - 3 x UARTs up to 1 Mbps, one UART extended to support ISO7816
 - 2 SPI+™ controllers

- 2 I2C controllers at 100 kHz, 400 kHz, or 3.4 MHz
- PDM interface with hardware sample rate converter
- I2S/PCM master/slave interface up to eight channels
- USB 1.1 Full Speed device interface
- Analog interfaces
 - 8-channel 10-bit SAR ADC, 3.4 Msamples/s
 - 8-channel 14-bit $\Sigma\Delta$ ADC, 1000 samples/s
 - Haptic driver interface to LRA/ERM motors
 - Two matched White LED drivers
- Radio transceiver
 - Single wire antenna: no RF matching, or RX/TX switching required
 - Supply current at VBAT2:
TX: 3 mA, RX: 1.8 mA (with ideal DC-DC)
 - Configurable transmit output power -18 to +6 dBm
 - -97 dBm receiver sensitivity
- Packages:
 - VFBGA86, 6x6, 0.55 mm pitch
 - VFBGA100, 5x5, 0.475 mm pitch

Applications

- Fitness trackers
- Sport watches
- Smartwatches
- Voice-controlled remote controls
- Rechargeable keyboards
- Toys
- Consumer appliances
- Home automation
- Industrial automation

Key Benefits

- Lowest power consumption
- Smallest system size
- Lowest system cost

Contents

Key Features	1
Applications	3
Key Benefits	3
Contents	4
Figures	14
Tables.....	16
1. Block Diagram.....	38
2. Application Information	39
3. DA1469x Product Family.....	41
4. Pinout.....	42
4.1 VFBGA86 Pinout	42
4.2 VFBGA100 Pinout	53
5. Specifications.....	67
5.1 Absolute Maximum Ratings.....	68
5.2 Recommended Operating Conditions	68
5.3 DC Characteristics.....	68
5.4 Timing Characteristics	71
5.5 Thermal Characteristics.....	71
5.6 Reset Characteristics.....	71
5.7 Bandgap Characteristics.....	72
5.8 Brown-Out Detector Characteristics	72
5.9 General Purpose ADC Characteristics	72
5.10 $\Sigma\Delta$ ADC Characteristics.....	73
5.11 DC-DC Converter Characteristics	74
5.12 LDOs Characteristics.....	76
5.13 32 kHz Crystal Oscillator Characteristics	81
5.14 32 MHz Crystal Oscillator Characteristics	82
5.15 RCX Oscillator Characteristics	82
5.16 32MHz RC Oscillator Characteristics	82
5.17 PLL Characteristics.....	82
5.18 Charger Characteristics	83
5.19 Battery Check Characteristics	86
5.20 Digital I/O Characteristics	86
5.21 QSPI Characteristics	87
5.22 LED Characteristics.....	88
5.23 LRA Characteristics	88
5.24 USB Characteristics.....	89
5.25 USB Charger Detection Characteristics	89
5.26 Radio Characteristics.....	90
6. System Overview	98
6.1 Internal Blocks	98

6.2	Digital Power Domains	99
6.3	Hardware FSM (POWERUP, WAKEUP, GOTO Sleep).....	100
6.3.1	Hardware FSM	100
6.3.2	POWERUP.....	101
6.3.3	WAKEUP Options	102
6.3.3.1	Slow WAKEUP.....	102
6.3.3.2	Fast Wake-up.....	103
6.3.3.3	Ultra-Fast Wake-up.....	103
6.3.4	Go-To-Sleep.....	104
6.4	Power Modes and Rails.....	104
6.5	OTP.....	109
6.5.1	OTP Segments.....	109
6.5.2	Configuration Script.....	109
6.5.3	Keys and Indexing.....	110
6.5.4	Customer Application Area	111
6.6	Flash.....	111
6.7	Bootling.....	113
6.7.1	Initialization.....	115
6.7.2	Configuration Script.....	115
6.7.3	Retrieve Application Code.....	115
6.7.4	Device Administration	115
6.7.5	Load Image	115
6.8	Memory Map.....	116
6.9	Resource Sharing.....	119
6.10	Remapping	120
6.11	Security Features.....	120
6.11.1	Secure Keys Manipulation	121
6.11.2	Secure Boot.....	121
6.11.3	Secure Access	121
6.11.4	Validation.....	121
6.11.5	Cryptography Operations	121
7.	Power	122
7.1	Introduction	122
7.2	Architecture.....	123
7.2.1	SIMO DC-DC Converter.....	123
7.2.2	LDOs	124
7.2.3	Switching between DC-DC and LDOs	124
7.2.4	Low Power Clamps	125
7.2.5	Battery Check.....	125
7.2.6	Charger	125
7.2.6.1	JEITA	126
7.2.6.2	Errors and Flags	128
7.2.6.3	Timers	129

7.2.7	Charger Detection	130
7.2.7.1	Contact Detection	131
7.2.7.2	Primary Charger Detection	131
7.2.7.3	Secondary Charger Detection	131
7.2.7.4	Smartphone Charger Detection	131
7.2.8	Rails Discharge	132
8.	Power Domain Controller (PDC).....	133
8.1	Introduction	133
8.2	Architecture.....	134
8.2.1	Look-Up Table.....	134
8.2.2	Operation.....	135
8.3	Programming	136
9.	Brown-Out Detector.....	137
9.1	Introduction	137
9.2	Architecture.....	137
9.2.1	Brown-Out Detector Monitor Levels	137
9.2.2	Brown-Out Detector Clock	138
9.3	Programming	138
10.	Reset	139
10.1	Introduction	139
10.2	Architecture.....	140
10.2.1	Power-On Reset from Pin	142
10.3	Programming	143
11.	Arm® Cortex®-M3.....	144
11.1	Introduction	144
11.2	Architecture.....	144
11.2.1	Interrupts	144
11.2.2	Reference.....	146
12.	Cache Controller	147
12.1	Introduction	147
12.2	Architecture.....	148
12.2.1	Cacheable Range	148
12.2.2	Runtime Reconfiguration.....	148
12.2.2.1	Cache Line Reconfiguration	148
12.2.2.2	TAG Memory Word.....	149
12.2.2.3	Associativity Reconfiguration.....	149
12.2.3	Replacement Strategy.....	149
12.2.4	Cache Reset.....	149
12.2.5	Miss Rate Monitor	149
12.2.6	Miss Latency and Power.....	150
12.3	Programming	150
12.3.1	Cache Controller Programming.....	150
12.3.2	Miss Rate Monitor Programming.....	151

13. Bus	152
13.1 Introduction	152
13.2 Architecture.....	153
14. Configurable MAC (CMAC)	155
14.1 Introduction	155
14.2 Architecture.....	156
14.2.1 Dataflow	156
14.2.2 Diagnostics.....	156
15. Sensor Node Controller (SNC)	157
15.1 Introduction	157
15.2 Architecture.....	157
15.2.1 Sensor Node Instruction Set	158
15.2.2 SNC Clocking Considerations.....	159
15.3 Programming	160
16. Memory Controller	161
16.1 Introduction	161
16.2 Architecture.....	161
16.3 Programming	162
17. Clock Generation	165
17.1 Clock Tree	165
17.2 Crystal Oscillators.....	167
17.2.1 Frequency Control (32 MHz Crystal)	167
17.3 RC Oscillators.....	168
17.3.1 Frequency Calibration	168
17.4 PLL.....	169
18. OTP Controller	170
18.1 Introduction	170
18.2 Architecture.....	170
18.3 Programming	171
19. Quad SPI Flash Controller	173
19.1 Introduction	173
19.2 Architecture.....	174
19.2.1 Interface	174
19.2.2 Initialization FSM.....	174
19.2.3 SPI Modes.....	175
19.2.4 Access Modes	175
19.2.5 Endianess.....	176
19.2.6 Erase Suspend/Resume	176
19.2.7 On-the-fly Decryption	177
19.2.8 Timing.....	179
19.3 Programming	180
19.3.1 Auto Mode	180
19.3.2 Manual Mode.....	180

19.3.3	Clock Selection.....	181
19.3.4	Receiving Data.....	181
19.3.5	Delay Line Configuration.....	181
20.	Quad SPI RAM/Flash Controller.....	182
20.1	Introduction.....	182
20.2	Architecture.....	182
20.2.1	Interface.....	182
20.2.2	SPI Modes.....	183
20.2.3	Access Modes.....	183
20.2.4	Endianness.....	184
20.2.5	Erase Suspend/Resume.....	184
20.2.6	Low Power Considerations.....	186
20.3	Programming.....	187
20.3.1	Auto Mode.....	187
20.3.2	Manual Mode.....	188
20.3.3	Clock Selection.....	188
20.3.4	Received Data.....	188
20.3.5	Delay Line Configuration.....	188
21.	Step Motor Controller.....	189
21.1	Introduction.....	189
21.2	Architecture.....	190
21.2.1	Commands and Waves.....	190
21.2.2	Pattern Generators (PGs).....	192
21.2.3	Interrupt Generator.....	192
21.3	Programming.....	193
22.	LCD Controller.....	194
22.1	Introduction.....	194
22.2	Architecture.....	195
22.2.1	Parallel LCD Interfaces.....	195
22.2.1.1	HSYNC/VSYNC Parallel Interface.....	195
22.2.1.2	JDI Parallel Interface.....	195
22.2.2	Serial LCD Interfaces.....	196
22.2.2.1	SPI3/4 Serial Interface.....	196
22.2.2.2	JDI SPI Serial Interface.....	197
22.2.3	Color Input Formats.....	198
22.2.4	Color Output Formats.....	199
22.2.4.1	SPI Output Formats.....	199
22.2.4.2	JDI SPI Output Formats.....	200
22.3	Programming.....	200
23.	DMA Controller.....	201
23.1	Introduction.....	201
23.2	Architecture.....	202
23.2.1	DMA Peripherals.....	202

23.2.2	Input/Output Multiplexer	202
23.2.3	DMA Channel Operation	202
23.2.4	DMA Arbitration	203
23.2.5	Freeze DMA Channels	204
23.2.6	Secure DMA Channel	204
23.3	Programming	204
23.3.1	Memory to Memory Transfer	204
23.3.2	Peripheral to Memory Transfer	204
24.	Crypto Engine	206
24.1	Introduction	206
24.2	Architecture	206
24.2.1	AES	207
24.2.2	Operation Modes	207
24.2.3	HASH	207
24.3	Programming	207
24.3.1	AES Engine Programming	207
24.3.2	HASH Engine Programming	208
25.	True Random Number Generator	209
25.1	Introduction	209
25.2	Architecture	209
25.3	Programming	209
26.	Wake-Up Controller	211
26.1	Introduction	211
26.2	Architecture	211
26.3	Programming	212
27.	General Purpose ADC	213
27.1	Introduction	213
27.2	Architecture	213
27.2.1	Input Channels and Input Scale	214
27.2.2	Operation	215
27.2.2.1	Enabling the ADC	216
27.2.3	Operating Modes	217
27.2.3.1	Manual Mode	217
27.2.3.2	Continuous Mode	217
27.2.4	Conversion Modes	218
27.2.4.1	ADC Conversion	218
27.2.4.2	Oversampling Mode	219
27.2.4.3	Chopper Mode	219
27.2.5	Additional Settings	220
27.2.6	Non-Ideal Effects	220
27.2.7	Offset Calibration	220
27.2.8	Zero-Scale Adjustment	221
27.2.9	Common Mode Adjustment	221

27.2.10	Input Impedance, Inductance and Input Settling.....	221
27.2.11	Reading Temperature Sensors	221
27.3	Programming	222
28.	ΣΔ ADC	223
28.1	Introduction	223
28.2	Architecture.....	223
28.3	Programming	224
29.	Audio Unit (AU)	225
29.1	Introduction	225
29.2	Architecture.....	226
29.2.1	Data Paths.....	226
29.2.2	Up/Down Sampler	226
29.2.3	PCM Interface	227
29.2.3.1	Channel Access and Delay.....	227
29.2.3.2	Clock Generation	227
29.2.3.3	External Synchronization	230
29.2.3.4	Data Formats	230
29.2.4	PDM Interface	233
29.2.5	DMA Support.....	234
29.2.6	Interrupts	234
29.3	Programming	234
29.3.1	PDM Input to PCM Output	234
30.	I2C Interface	236
30.1	Introduction	236
30.2	Architecture.....	237
30.2.1	I2C Behavior.....	237
30.2.1.1	START and STOP Generation	237
30.2.1.2	Combined Formats	238
30.2.2	I2C Protocols.....	238
30.2.2.1	START and STOP Conditions	238
30.2.2.2	Addressing Slave Protocol.....	238
30.2.2.3	Transmitting and Receiving Protocols	239
30.2.3	Multiple Master Arbitration	241
30.2.4	Clock Synchronization.....	242
30.3	Programming	242
31.	UART	244
31.1	Introduction	244
31.2	Architecture.....	245
31.2.1	UART (RS232) Serial Protocol.....	245
31.2.2	Clock Support.....	246
31.2.3	Interrupts	246
31.2.4	Programmable THRE Interrupt	247
31.2.5	Shadow Registers	249

31.2.6	Direct Test Mode	249
31.3	Programming	249
32.	Smart Card Interface	251
32.1	Introduction	251
32.2	Architecture.....	251
32.2.1	ISO7816-3 Clock Generation	251
32.2.2	ISO7816-3 Timer – Guard Time.....	251
32.2.3	ISO7816-3 Error Detection.....	252
32.3	Programming	252
33.	SPI+ Interface	254
33.1	Introduction	254
33.2	Architecture.....	255
33.2.1	Master Mode	255
33.2.2	Slave Mode	255
33.2.3	SPI_POL and SPI_PHA	255
33.2.4	SPI_DO Idle Levels.....	255
33.2.5	Write Only Mode.....	255
33.2.6	Read Only Mode	255
33.2.7	Bidirectional Transfers with FIFO.....	256
33.2.8	TXreq Mode.....	256
33.2.9	DMA Operation Requirements	256
33.2.10	The 9-Bit Mode.....	256
33.2.11	Timing Diagrams	256
33.2.12	SPI Timing.....	257
33.3	Programming	258
34.	Real Time Clock.....	260
34.1	Introduction	260
34.2	Architecture.....	260
34.3	Programming	261
35.	General Purpose Timers	263
35.1	Introduction	263
35.2	Architecture.....	263
35.3	Programming	264
36.	Watchdog Timers.....	266
36.1	Introduction	266
36.2	Architecture.....	266
36.3	Programming	267
36.3.1	System Watchdog.....	267
36.3.2	CMAC Watchdog.....	267
37.	USB Controller	269
37.1	Introduction	269
37.2	Architecture.....	270
37.2.1	Serial Interface Engine.....	270

37.2.2	Endpoint Pipe Controller (EPC)	270
37.2.3	Functional States	272
37.2.3.1	Line Condition Detection.....	272
37.2.4	Functional State Diagram.....	272
37.2.5	Address Detection.....	274
37.2.6	Transmit and Receive Endpoint FIFOs.....	275
37.2.7	Bidirectional Control Endpoint FIFO0	276
37.2.8	Transmit Endpoint FIFO.....	277
37.2.9	Receive Endpoint FIFO.....	278
37.2.10	Interrupt Hierarchy	279
37.2.11	USB Power Saving Modes.....	280
37.2.11.1	Freezing USB Node.....	281
37.2.11.2	Integrated Resistors.....	281
38.	Haptic Driver	283
38.1	Introduction	283
38.2	Architecture.....	283
38.2.1	Resonance Control	285
38.3	Programming	286
38.4	Legal	286
39.	LEDs Driver	287
39.1	Introduction	287
39.2	Architecture.....	287
39.3	Programming	288
40.	Input/Output Ports	289
40.1	Introduction	289
40.2	Architecture.....	289
40.2.1	Programmable Pin Assignment.....	289
40.2.1.1	Priority.....	290
40.2.1.2	Direction Control	290
40.2.2	General Purpose Port Registers	290
40.2.2.1	Port Data Register	290
40.2.2.2	Port Set Data Output Register	290
40.2.2.3	Port Reset Data Output Register	290
40.2.3	Fixed Assignment Functionality	291
40.2.4	GPIO State Retention While Sleeping	294
40.2.5	Special I/O Considerations.....	294
41.	Radio.....	296
41.1	Introduction	296
41.2	Architecture.....	296
41.2.1	Receiver	296
41.2.2	Synthesizer.....	296
41.2.3	Transmitter	297
41.2.4	RFIO.....	297

41.2.5	Biasing.....	297
41.2.6	RF Monitoring.....	297
42.	Registers.....	298
42.1	AMBA Bus Registers	298
42.2	LCD Controller Registers.....	300
42.3	LRA/ERM Registers.....	311
42.4	Memory Controller Registers.....	318
42.5	OTP Controller Registers.....	326
42.6	LED Controller Registers	330
42.7	QSPI Flash Registers	331
42.8	QSPI Ram Registers	345
42.9	RF Monitor Registers.....	359
42.10	Real Time Clock Registers	361
42.11	Motor Controller Registers.....	367
42.12	Sensor Node Controller Registers.....	374
42.13	SPI Controller Registers	379
42.14	Timers Registers.....	383
42.15	True Random Number Generator Controller Registers.....	398
42.16	UART Registers.....	399
42.17	USB Controller Registers.....	476
42.18	Silicon Version Registers.....	508
42.19	Wake-Up Controller Registers	510
42.20	Watchdog Controller Registers.....	512
42.21	General Purpose / $\Sigma\Delta$ ADC Registers	514
42.22	General Purpose I/O Registers	519
42.23	General Purpose Registers	541
42.24	I2C Controller Registers	544
42.25	Power Domain Controller Registers	588
42.26	DCDC Converter Registers	596
42.27	DMA Controller Registers.....	602
42.28	Charger Registers.....	628
42.29	Clock Generation Controller Registers.....	659
42.30	Cache Controller Registers	697
42.31	Audio Unit Registers	702
42.32	Analog Miscellaneous Registers	708
42.33	Crypto-Engine Registers	709
43.	Ordering Information.....	714
44.	Package Information	715
44.1	Moisture Sensitivity Level (MSL)	715
44.2	Soldering Information.....	715
44.3	Package Outlines.....	716
45.	Revision History	718

Figures

Figure 1. DA1469x block diagram	38
Figure 2. Activity tracker	39
Figure 3. Analog watch	39
Figure 4. Sport watch.....	40
Figure 5. VFBGA86 ball assignment	42
Figure 6. VFBGA100 ball assignment	53
Figure 7. Digital power domains and blocks mapping	100
Figure 8. POWERUP, WAKEUP, GOTO Sleep hardware FSM.....	101
Figure 9. POWERUP timing diagram	102
Figure 10. Slow wake-up timing.....	103
Figure 11. Fast wake-up timing	103
Figure 12. Ultra-fast wake-up timing.....	104
Figure 13. Flash regions and layout	112
Figure 14. BootROM flowchart	114
Figure 15. Power management unit architecture.....	122
Figure 16. SIMO DCDC block diagram	123
Figure 17. Battery check block diagram	125
Figure 18. Charger hardware finite state machine diagram	126
Figure 19. NTC battery monitoring connections	127
Figure 20. Battery temperature monitoring FSM	128
Figure 21. Charger detection circuit	130
Figure 22. Power rail discharging feature.....	132
Figure 23. Power	133
Figure 24. Brown-out detector block diagram.....	137
Figure 25. BOD FSM timing diagram in Sleep mode	138
Figure 26. Reset block diagram.....	139
Figure 27. Power-on reset timing diagram	143
Figure 28. Cache controller block diagram.....	148
Figure 29. Cache line size reconfiguration example	149
Figure 30. Bus architecture.....	153
Figure 31. Configurable MAC block diagram.....	155
Figure 32. CMAC diagnostics timing diagram	156
Figure 33. Sensor node controller block diagram.....	157
Figure 34. Internal architecture of the memory controller.....	161
Figure 35. Example of memory segments mapping	163
Figure 36. Clock tree diagram	166
Figure 37. Crystal oscillator circuits	167
Figure 38. XTAL32MHz oscillator frequency trimming	168
Figure 39. OTP controller block diagram.....	170
Figure 40. QSPI flash controller block diagram	173
Figure 41. Erase suspend/resume in Auto mode	177
Figure 42. QSPI input timing.....	179
Figure 43: QSPI output timing	179
Figure 44. Quad SPI RAM/Flash controller	182
Figure 45. Erase suspend/resume in Auto mode	185
Figure 46. QSPI Split burst timing for low power (QSPI_FORENSEQ_EN=1)	186

Figure 47. QSPI Burst timing for high performance (QSPI_FORENSEQ_EN=0)	186
Figure 48. Motor Controller block diagram	189
Figure 49. Commands and waveform format	190
Figure 50. Loading waves into waves memory space	191
Figure 51. Waveform generation in signal pairs	192
Figure 52. LCD controller block diagram	194
Figure 53: HSYNC/VSYNC Typical Waveform	195
Figure 54. HSYNC/VSYNC color bits waveform	195
Figure 55. DMA controller block diagram	201
Figure 56. DMA channel diagram	203
Figure 57. AES/HASH architecture	206
Figure 58. TRNG block diagram	209
Figure 59: Wake-up controller block diagram	211
Figure 60: General-purpose ADC block diagram	213
Figure 61. GPADC operation flow diagram	216
Figure 62. Block diagram of the $\Delta\Sigma$ ADC	223
Figure 63. Audio unit block diagram	226
Figure 64. PCM interface formats	231
Figure 65. I2S mode	232
Figure 66. TDM mode (left justified mode)	232
Figure 67. IOM format	233
Figure 68. PDM Mono/Stereo formats	233
Figure 69. SRC PDM input transfer function	233
Figure 70. I2C Controller block diagram	236
Figure 71. Data transfer on the I2C bus	237
Figure 72. START and STOP conditions	238
Figure 73. 7-bit address format	239
Figure 74. 10-bit address format	239
Figure 75. Master-Transmitter protocol	240
Figure 76. Master-Receiver protocol	240
Figure 77. START BYTE transfer	241
Figure 78. Multiple Master arbitration	242
Figure 79. Multiple Master clock synchronization	242
Figure 80. UART block diagram	244
Figure 81. Serial data format	245
Figure 82. Receiver serial data sampling points	245
Figure 83. Flowchart of interrupt generation for programmable THRE Interrupt mode	248
Figure 84. Flowchart of interrupt generation when not in programmable THRE Interrupt mode	249
Figure 85. Smart Card (ISO7816-3) block diagram	251
Figure 86. SPI block diagram	254
Figure 87. SPI Master/Slave mode 0: SPI_POL=0 and SPI_PHA=0	256
Figure 88. SPI Master/Slave mode 1: SPI_POL=0 and SPI_PHA=1	257
Figure 89. SPI Master/Slave mode 2: SPI_POL=1 and SPI_PHA=0	257
Figure 90. SPI Master/slave mode 3: SPI_POL=1 and SPI_PHA=1	257
Figure 91. SPI Slave mode timing (CPOL = 0, CPHA = 0)	258
Figure 92. Real Time Clock block diagram	260
Figure 93. General Purpose Timer's block diagram	263
Figure 94. System watchdog block diagram	266

Figure 95. USB Node block diagram	269
Figure 96. Endpoint operation	270
Figure 97. Node Functional State Diagram	273
Figure 98. USB function address/endpoint decoding	275
Figure 99. Endpoint 0 operation	277
Figure 100. USB Tx FIFO operation	278
Figure 101. USB Rx FIFO operation	279
Figure 102. USB Interrupt register hierarchy	280
Figure 103. USB_Dp resistor switching	281
Figure 104. USB_Dm resistor switching	282
Figure 105. Block diagram of the haptic driver	283
Figure 106. Circuit diagram of the Haptic Driver and Equivalent electrical model of an LRA	285
Figure 107. LED Driver block diagram	287
Figure 108. Port P0 and P1 with Programmable Pin Assignment	289
Figure 109. Latching of digital pad signals	294
Figure 110. Latching of QSPI pad signals	294
Figure 111. Radio block diagram	296
Figure 112. VFBGA86 Package outline drawing	716
Figure 113. VFBGA100 Package outline drawing	717

Tables

Table 1: DA1469x product family differentiation	41
Table 2: DA14691/5 pin description	42
Table 3: DA14697/9 pin description	54
Table 4: Absolute maximum ratings	68
Table 5: Recommended operating conditions	68
Table 6: DC characteristics	68
Table 7: Timing characteristics	71
Table 8: Thermal characteristics	71
Table 9: PAD_RESET - DC characteristics	71
Table 10: BG_REF - DC characteristics	72
Table 11: BOD - DC characteristics	72
Table 12: GP_ADC - Recommended operating conditions	72
Table 13: GP_ADC - DC characteristics	72
Table 14: GP_ADC - Timing characteristics	73
Table 15: SD_ADC - DC characteristics	73
Table 16: SD_ADC - Electrical performance	74
Table 17: DCDC - Recommended operating conditions	74
Table 18: DCDC - DC characteristics	74
Table 19: LDO_1v8 - Recommended operating conditions	76
Table 20: LDO_1v8 - DC characteristics	76
Table 21: LDO_1v8 - AC characteristics	76
Table 22: LDO_1v8_RET - Recommended operating conditions	76
Table 23: LDO_1v8_RET - DC characteristics	77
Table 24: LDO_1V8P - Recommended operating conditions	77
Table 25: LDO_1V8P - DC characteristics	77
Table 26: LDO_1V8P - AC characteristics	78

Table 27: LDO_1V8P_RET - Recommended operating conditions	78
Table 28: LDO_1V8P_RET - DC characteristics.....	78
Table 29: LDO_CORE - Recommended operating conditions.....	78
Table 30: LDO_CORE - DC characteristics	78
Table 31: LDO_CORE_RET - Recommended operating conditions.....	79
Table 32: LDO_CORE_RET - DC characteristics	79
Table 33: LDO_USB - Recommended operating conditions.....	79
Table 34: LDO_USB - DC characteristics	79
Table 35: LDO_VBAT - Recommended operating conditions.....	80
Table 36: LDO_VBAT - DC characteristics	80
Table 37: LDO_VBAT_RET - Recommended operating conditions.....	80
Table 38: LDO_VBAT_RET - DC characteristics	80
Table 39: OSC_XTAL32K - Recommended operating conditions	81
Table 40: OSC_XTAL32K - DC characteristics.....	81
Table 41: OSC_XTAL32K - Timing characteristics	81
Table 42: OSC_XTAL32MEG - Recommended operating conditions.....	82
Table 43: OSC_RCX - Timing characteristics	82
Table 44: OSC_RC32MEG - Timing characteristics	82
Table 45: PLL_SYS - DC characteristics.....	82
Table 46: PLL_SYS - Timing characteristics.....	83
Table 47: Charger - DC characteristics	83
Table 48: BATCHECK - DC characteristics.....	86
Table 49: GPIO - DC characteristics	86
Table 50: GPIO_LOWDRV - DC characteristics	87
Table 51: QSPIF pad - DC characteristics	87
Table 52: QSPIR pad - DC characteristics	87
Table 53: LED_DRIVER - DC characteristics.....	88
Table 54: LED_DRIVER - AC characteristics.....	88
Table 55: LRA - Recommended operating conditions.....	88
Table 56: LRA - DC characteristics	88
Table 57: LRA - AC characteristics	89
Table 58: GPIO_USB - DC characteristics.....	89
Table 59: USB_CHRG_DET - DC characteristics.....	89
Table 60: Radio BLE 1M - Recommended operating conditions	90
Table 61: Radio BLE 1M - DC characteristics.....	90
Table 62: Radio BLE 1M - AC characteristics	91
Table 63: Radio BLE 2M - Recommended operating conditions	93
Table 64: Radio BLE 2M - DC characteristics.....	93
Table 65: Radio BLE 2M - AC characteristics	94
Table 66: Power domains description	100
Table 67: Wake-up modes.....	102
Table 68: Power Rails Configuration	106
Table 69: OTP layout.....	109
Table 70: Configuration Script Commands and Description	109
Table 71: Configuration script example	110
Table 72: Memory map.....	116
Table 73: Busy status register	120
Table 74: Remapping options.....	120

Table 75: Security configuration options	120
Table 76: Charger error flags.....	129
Table 77: USBP, USBN contact detection.....	131
Table 78: Charger Type Detection	131
Table 79: Secondary charger detection.....	131
Table 80: Smartphone charger characteristics.....	131
Table 81: PDC LUT format	134
Table 82: Peripheral trigger encoding	134
Table 83: Master trigger encoding.....	135
Table 84: Brown-out detectors and default levels	138
Table 85: Reset Signals and Registers	140
Table 86: Interrupt list.....	144
Table 87: TAG Memory layout.....	149
Table 88: QSPI Flash cache miss latency.....	150
Table 89: AHB-DMA master priorities	154
Table 90: CMAC diagnostic signals.....	156
Table 91: Sensor Node Instruction Set Overview.....	158
Table 92: Opcode and operand sizes.....	159
Table 93: Memory controller masters access metrics	162
Table 94: Memory segments description.....	162
Table 95: Initialization command encoding	175
Table 96: Flash initialization uCode example	175
Table 97: QSPI timing parameters	179
Table 98: Commands format	190
Table 99: Waves format.....	191
Table 100: Hand Position and Restoration Error.....	192
Table 101: HSYNC/VSYNC parallel I/F pinout.....	195
Table 102: JDI parallel I/F pinout.....	195
Table 103: SPI3/4 serial I/F pinout	196
Table 104: JDI SPI serial I/F pinout.....	197
Table 105: L1 grayscale/palette.....	198
Table 106: L4 grayscale/palette.....	198
Table 107: L8 grayscale/palette.....	198
Table 108: 8-bit RGB332	198
Table 109: 16-bit RGB565	198
Table 110: 16-bit RGBX5551.....	198
Table 111: 32-bit RGBX8888.....	198
Table 112: 32-bit XRGB8888.....	198
Table 113: 32-bit ABGR8888.....	198
Table 114: 32-bit BGRA8888.....	198
Table 115: SPI3/4 – 8-bit RGB-332.....	199
Table 116: SPI3/4 – 8-bit RGB-444	199
Table 117: SPI3/4 – 8-bit RGB-565.....	199
Table 118: SPI3/4 – 8-bit RGB-666	199
Table 119: SPI3/4 – 8-bit RGB-888	199
Table 120: JDI SPI – 8-bit RGB-111-1 (3-bit mode).....	200
Table 121: JDI SPI – 8-bit RGB-111-2 (4-bit mode).....	200
Table 122: JDI SPI – 8-bit RGB-111-3 (3-bit mode).....	200

Table 123: JDI SPI – 8-bit RGB-111-4 (1-bit mode).....	200
Table 124: DMA controller.....	201
Table 124: DMA served peripherals.....	202
Table 126: Crypto engine.....	206
Table 127: True random number generator.....	209
Table 128: Wake-up controller.....	211
Table 125: GPADC input channels and voltage range.....	214
Table 126: ADC_LDO_1V2 Start-Up delay.....	217
Table 127: ADC sampling time constant.....	218
Table 128: Total ADC conversion time.....	219
Table 129: Oversampling mode effective number of bits.....	219
Table 130: Preferred settings for ENOB measurements.....	219
Table 131: GPADC calibration procedure for single-ended and differential modes.....	220
Table 132: Common mode adjustment.....	221
Table 133: PCM_FDIV_REG programming example.....	227
Table 134: Fractional and Integer Only clock divisors for various PCM frequencies and sample rates.....	228
Table 135: I2C definition of bits in first byte.....	239
Table 136: UART baud rate generation.....	245
Table 137: UART2/3 baud rate generation.....	246
Table 138: UART interrupt priorities.....	247
Table 139: SPI timing parameters.....	258
Table 140: Timer's Input GPIOs.....	264
Table 141: Functional States.....	273
Table 142: USB Node Endpoint Sizes.....	275
Table 143: Fixed assignment of specific signals.....	291
Table 144: Register map DW.....	298
Table 145: AHB_DMA_PL1_REG (0x30020000).....	298
Table 146: AHB_DMA_PL2_REG (0x30020004).....	298
Table 147: AHB_DMA_PL3_REG (0x30020008).....	299
Table 148: AHB_DMA_PL4_REG (0x3002000C).....	299
Table 149: AHB_DMA_DFLT_MASTER_REG (0x30020048).....	299
Table 150: AHB_DMA_WTEN_REG (0x3002004C).....	299
Table 151: AHB_DMA_TCL_REG (0x30020050).....	299
Table 152: AHB_DMA_CCLM1_REG (0x30020054).....	299
Table 153: AHB_DMA_CCLM2_REG (0x30020058).....	300
Table 154: AHB_DMA_CCLM3_REG (0x3002005C).....	300
Table 155: AHB_DMA_CCLM4_REG (0x30020060).....	300
Table 156: AHB_DMA_VERSION_REG (0x30020090).....	300
Table 157: Register map LCDC.....	300
Table 158: LCDC_MODE_REG (0x30030000).....	302
Table 159: LCDC_CLKCTRL_REG (0x30030004).....	303
Table 160: LCDC_BGCOLOR_REG (0x30030008).....	303
Table 161: LCDC_RESXY_REG (0x3003000C).....	303
Table 162: LCDC_FRONTPORCHXY_REG (0x30030014).....	304
Table 163: LCDC_BLANKINGXY_REG (0x30030018).....	304
Table 164: LCDC_BACKPORCHXY_REG (0x3003001C).....	304
Table 165: LCDC_DBIB_CFG_REG (0x30030028).....	304
Table 166: LCDC_GPIO_REG (0x3003002C).....	306

Table 167: LCDC_LAYER0_MODE_REG (0x30030030)	306
Table 168: LCDC_LAYER0_STARTXY_REG (0x30030034)	306
Table 169: LCDC_LAYER0_SIZEXY_REG (0x30030038)	306
Table 170: LCDC_LAYER0_BASEADDR_REG (0x3003003C)	306
Table 171: LCDC_LAYER0_STRIDE_REG (0x30030040)	307
Table 172: LCDC_LAYER0_RESXY_REG (0x30030044)	307
Table 173: LCDC_JDI_RESXY_REG (0x30030090)	307
Table 174: LCDC_JDI_FBX_BLANKING_REG (0x30030094)	307
Table 175: LCDC_JDI_FBY_BLANKING_REG (0x30030098)	307
Table 176: LCDC_JDI_HCK_WIDTH_REG (0x3003009C)	308
Table 177: LCDC_JDI_XRST_WIDTH_REG (0x300300A0)	308
Table 178: LCDC_JDI_VST_DELAY_REG (0x300300A4)	308
Table 179: LCDC_JDI_VST_WIDTH_REG (0x300300A8)	308
Table 180: LCDC_JDI_VCK_DELAY_REG (0x300300AC)	308
Table 181: LCDC_JDI_HST_DELAY_REG (0x300300B0)	308
Table 182: LCDC_JDI_HST_WIDTH_REG (0x300300B4)	308
Table 183: LCDC_JDI_ENB_START_HLINE_REG (0x300300B8)	308
Table 184: LCDC_JDI_ENB_END_HLINE_REG (0x300300BC)	309
Table 185: LCDC_JDI_ENB_START_CLK_REG (0x300300C0)	309
Table 186: LCDC_JDI_ENB_WIDTH_CLK_REG (0x300300C4)	309
Table 187: LCDC_DBIB_CMD_REG (0x300300E8)	309
Table 188: LCDC_IDREG_REG (0x300300F4)	309
Table 189: LCDC_INTERRUPT_REG (0x300300F8)	309
Table 190: LCDC_STATUS_REG (0x300300FC)	310
Table 191: LCDC_CRC_REG (0x30030184)	311
Table 192: LCDC_LAYER0_OFFSETX_REG (0x30030188)	311
Table 193: Register map LRA	311
Table 194: LRA_CTRL1_REG (0x50030A00)	312
Table 195: LRA_CTRL2_REG (0x50030A04)	313
Table 196: LRA_CTRL3_REG (0x50030A08)	313
Table 197: LRA_FLT_SMP1_REG (0x50030A0C)	313
Table 198: LRA_FLT_SMP2_REG (0x50030A10)	314
Table 199: LRA_FLT_SMP3_REG (0x50030A14)	314
Table 200: LRA_FLT_SMP4_REG (0x50030A18)	314
Table 201: LRA_FLT_SMP5_REG (0x50030A1C)	314
Table 202: LRA_FLT_SMP6_REG (0x50030A20)	314
Table 203: LRA_FLT_SMP7_REG (0x50030A24)	314
Table 204: LRA_FLT_SMP8_REG (0x50030A28)	315
Table 205: LRA_FLT_COEF1_REG (0x50030A2C)	315
Table 206: LRA_FLT_COEF2_REG (0x50030A30)	315
Table 207: LRA_FLT_COEF3_REG (0x50030A34)	315
Table 208: LRA_BRD_LS_REG (0x50030A38)	315
Table 209: LRA_BRD_HS_REG (0x50030A3C)	316
Table 210: LRA_BRD_STAT_REG (0x50030A40)	316
Table 211: LRA_ADC_CTRL1_REG (0x50030A44)	317
Table 212: LRA_ADC_RESULT_REG (0x50030A50)	317
Table 213: LRA_LDO_REG (0x50030A54)	318
Table 214: LRA_DFT_REG (0x50030A58)	318

Table 215: Register map MEMCTRL	319
Table 216: MEM_PRIO_REG (0x50050004)	319
Table 217: MEM_STALL_REG (0x50050008)	319
Table 218: MEM_STATUS_REG (0x5005000C)	320
Table 219: MEM_STATUS2_REG (0x50050010)	320
Table 220: CMI_CODE_BASE_REG (0x50050020)	321
Table 221: CMI_DATA_BASE_REG (0x50050024)	321
Table 222: CMI_SHARED_BASE_REG (0x50050028)	321
Table 223: CMI_END_REG (0x5005002C)	321
Table 224: SNC_BASE_REG (0x50050030)	322
Table 225: BUSY_SET_REG (0x50050074)	322
Table 226: BUSY_RESET_REG (0x50050078)	324
Table 227: BUSY_STAT_REG (0x5005007C)	325
Table 228: Register map OTPC	326
Table 229: OTPC_MODE_REG (0x30070000)	326
Table 230: OTPC_STAT_REG (0x30070004)	327
Table 231: OTPC_PADDR_REG (0x30070008)	328
Table 232: OTPC_PWORD_REG (0x3007000C)	328
Table 233: OTPC_TIM1_REG (0x30070010)	329
Table 234: OTPC_TIM2_REG (0x30070014)	329
Table 235: Register map PWM for LEDs	330
Table 236: PWMLLED_DUTY_CYCLE_LED1_REG (0x50030500)	330
Table 237: PWMLLED_DUTY_CYCLE_LED2_REG (0x50030504)	331
Table 238: PWMLLED_FREQUENCY_REG (0x50030508)	331
Table 239: PWMLLED_CTRL_REG (0x5003050C)	331
Table 240: Register map QSPIC	331
Table 241: QSPIC_CTRLBUS_REG (0x38000000)	333
Table 242: QSPIC_CTRLMODE_REG (0x38000004)	333
Table 243: QSPIC_RECVDATA_REG (0x38000008)	335
Table 244: QSPIC_BURSTCMDA_REG (0x3800000C)	335
Table 245: QSPIC_BURSTCMDDB_REG (0x38000010)	336
Table 246: QSPIC_STATUS_REG (0x38000014)	337
Table 247: QSPIC_WRITEDATA_REG (0x38000018)	337
Table 248: QSPIC_READDATA_REG (0x3800001C)	338
Table 249: QSPIC_DUMMYDATA_REG (0x38000020)	338
Table 250: QSPIC_ERASECTRL_REG (0x38000024)	338
Table 251: QSPIC_ERASECMDA_REG (0x38000028)	339
Table 252: QSPIC_ERASECMDDB_REG (0x3800002C)	339
Table 253: QSPIC_BURSTBRK_REG (0x38000030)	340
Table 254: QSPIC_STATUSCMD_REG (0x38000034)	341
Table 255: QSPIC_CHKERASE_REG (0x38000038)	342
Table 256: QSPIC_GP_REG (0x3800003C)	342
Table 257: QSPIC_UCODE_START (0x38000040)	342
Table 258: QSPIC_CTR_CTRL_REG (0x38000080)	342
Table 259: QSPIC_CTR_SADDR_REG (0x38000084)	343
Table 260: QSPIC_CTR_EADDR_REG (0x38000088)	343
Table 261: QSPIC_CTR_NONCE_0_3_REG (0x3800008C)	343
Table 262: QSPIC_CTR_NONCE_4_7_REG (0x38000090)	344

Table 263: QSPIC_CTRL_KEY_0_3_REG (0x38000094).....	344
Table 264: QSPIC_CTRL_KEY_4_7_REG (0x38000098).....	345
Table 265: QSPIC_CTRL_KEY_8_11_REG (0x3800009C).....	345
Table 266: QSPIC_CTRL_KEY_12_15_REG (0x380000A0).....	345
Table 267: QSPIC_CTRL_KEY_16_19_REG (0x380000A4).....	345
Table 268: QSPIC_CTRL_KEY_20_23_REG (0x380000A8).....	345
Table 269: QSPIC_CTRL_KEY_24_27_REG (0x380000AC).....	345
Table 270: QSPIC_CTRL_KEY_28_31_REG (0x380000B0).....	345
Table 271: Register map QSPIC2.....	345
Table 272: QSPIC2_CTRLBUS_REG (0x34000000).....	346
Table 273: QSPIC2_CTRLMODE_REG (0x34000004).....	347
Table 274: QSPIC2_RECVDATA_REG (0x34000008).....	349
Table 275: QSPIC2_BURSTCMDA_REG (0x3400000C).....	349
Table 276: QSPIC2_BURSTCMDDB_REG (0x34000010).....	350
Table 277: QSPIC2_STATUS_REG (0x34000014).....	351
Table 278: QSPIC2_WRITEDATA_REG (0x34000018).....	352
Table 279: QSPIC2_READDATA_REG (0x3400001C).....	352
Table 280: QSPIC2_DUMMYDATA_REG (0x34000020).....	352
Table 281: QSPIC2_ERASECTRL_REG (0x34000024).....	352
Table 282: QSPIC2_ERASECMDA_REG (0x34000028).....	353
Table 283: QSPIC2_ERASECMDDB_REG (0x3400002C).....	353
Table 284: QSPIC2_BURSTBRK_REG (0x34000030).....	355
Table 285: QSPIC2_STATUSCMD_REG (0x34000034).....	355
Table 286: QSPIC2_CHKERASE_REG (0x34000038).....	356
Table 287: QSPIC2_GP_REG (0x3400003C).....	357
Table 288: QSPIC2_AWRITECMD_REG (0x34000040).....	357
Table 289: QSPIC2_MEMBLN_REG (0x34000044).....	357
Table 290: Register map RFPT.....	359
Table 291: RFMON_CTRL_REG (0x50040600).....	359
Table 292: RFMON_ADDR_REG (0x50040604).....	360
Table 293: RFMON_LEN_REG (0x50040608).....	360
Table 294: RFMON_STAT_REG (0x5004060C).....	360
Table 295: RFMON_CRV_ADDR_REG (0x50040610).....	361
Table 296: RFMON_CRV_LEN_REG (0x50040614).....	361
Table 297: Register map RTC.....	361
Table 298: RTC_CONTROL_REG (0x50000400).....	362
Table 299: RTC_HOUR_MODE_REG (0x50000404).....	362
Table 300: RTC_TIME_REG (0x50000408).....	362
Table 301: RTC_CALENDAR_REG (0x5000040C).....	363
Table 302: RTC_TIME_ALARM_REG (0x50000410).....	363
Table 303: RTC_CALENDAR_ALARM_REG (0x50000414).....	363
Table 304: RTC_ALARM_ENABLE_REG (0x50000418).....	364
Table 305: RTC_EVENT_FLAGS_REG (0x5000041C).....	364
Table 306: RTC_INTERRUPT_ENABLE_REG (0x50000420).....	365
Table 307: RTC_INTERRUPT_DISABLE_REG (0x50000424).....	365
Table 308: RTC_INTERRUPT_MASK_REG (0x50000428).....	365
Table 309: RTC_STATUS_REG (0x5000042C).....	366
Table 310: RTC_KEEP_RTC_REG (0x50000430).....	366

Table 311: RTC_EVENT_CTRL_REG (0x50000480).....	366
Table 312: RTC_MOTOR_EVENT_PERIOD_REG (0x50000484).....	367
Table 313: RTC_PDC_EVENT_PERIOD_REG (0x50000488).....	367
Table 314: RTC_PDC_EVENT_CLEAR_REG (0x5000048C).....	367
Table 315: RTC_MOTOR_EVENT_CNT_REG (0x50000490).....	367
Table 316: RTC_PDC_EVENT_CNT_REG (0x50000494).....	367
Table 317: Register map SMOTOR	367
Table 318: SMOTOR_CTRL_REG (0x50030E00).....	368
Table 319: PG0_CTRL_REG (0x50030E04).....	369
Table 320: PG1_CTRL_REG (0x50030E08).....	369
Table 321: PG2_CTRL_REG (0x50030E0C).....	370
Table 322: PG3_CTRL_REG (0x50030E10).....	371
Table 323: PG4_CTRL_REG (0x50030E14).....	372
Table 324: SMOTOR_TRIGGER_REG (0x50030E18).....	372
Table 325: SMOTOR_CMD_FIFO_REG (0x50030E20).....	373
Table 326: SMOTOR_CMD_READ_PTR_REG (0x50030E24).....	373
Table 327: SMOTOR_CMD_WRITE_PTR_REG (0x50030E28).....	373
Table 328: SMOTOR_STATUS_REG (0x50030E2C).....	373
Table 329: SMOTOR_IRQ_CLEAR_REG (0x50030E30).....	374
Table 330: WAVETABLE_BASE (0x50030E40).....	374
Table 331: CMD_TABLE_BASE (0x50030E80).....	374
Table 332: Register map SNC.....	374
Table 333: SNC_CTRL_REG (0x50020C00).....	374
Table 334: SNC_STATUS_REG (0x50020C04).....	376
Table 335: SNC_LP_TIMER_REG (0x50020C08).....	378
Table 336: SNC_PC_REG (0x50020C0C).....	378
Table 337: SNC_R1_REG (0x50020C10).....	379
Table 338: SNC_R2_REG (0x50020C14).....	379
Table 339: SNC_TMP1_REG (0x50020C18).....	379
Table 340: SNC_TMP2_REG (0x50020C1C).....	379
Table 341: Register map SPI.....	379
Table 342: SPI_CTRL_REG (0x50020300).....	379
Table 343: SPI_RX_TX_REG (0x50020304).....	381
Table 344: SPI_CLEAR_INT_REG (0x50020308).....	381
Table 345: SPI2_CTRL_REG (0x50020400).....	381
Table 346: SPI2_RX_TX_REG (0x50020404).....	383
Table 347: SPI2_CLEAR_INT_REG (0x50020408).....	383
Table 348: Register map Timer1	384
Table 349: TIMER_CTRL_REG (0x50010200).....	386
Table 350: TIMER_TIMER_VAL_REG (0x50010204).....	387
Table 351: TIMER_STATUS_REG (0x50010208).....	387
Table 352: TIMER_GPIO1_CONF_REG (0x5001020C).....	387
Table 353: TIMER_GPIO2_CONF_REG (0x50010210).....	388
Table 354: TIMER_RELOAD_REG (0x50010214).....	388
Table 355: TIMER_SHOTWIDTH_REG (0x50010218).....	388
Table 356: TIMER_PRESCALER_REG (0x5001021C).....	388
Table 357: TIMER_CAPTURE_GPIO1_REG (0x50010220).....	388
Table 358: TIMER_CAPTURE_GPIO2_REG (0x50010224).....	388

Table 359: TIMER_PRESCALER_VAL_REG (0x50010228).....	389
Table 360: TIMER_PWM_FREQ_REG (0x5001022C).....	389
Table 361: TIMER_PWM_DC_REG (0x50010230).....	389
Table 362: TIMER_GPIO3_CONF_REG (0x50010234).....	389
Table 363: TIMER_GPIO4_CONF_REG (0x50010238).....	389
Table 364: TIMER_CAPTURE_GPIO3_REG (0x5001023C).....	389
Table 365: TIMER_CAPTURE_GPIO4_REG (0x50010240).....	389
Table 366: TIMER_CLEAR_GPIO_EVENT_REG (0x50010244).....	390
Table 367: TIMER_CLEAR_IRQ_REG (0x50010248).....	390
Table 368: TIMER2_CTRL_REG (0x50010300).....	390
Table 369: TIMER2_TIMER_VAL_REG (0x50010304).....	391
Table 370: TIMER2_STATUS_REG (0x50010308).....	391
Table 371: TIMER2_GPIO1_CONF_REG (0x5001030C).....	391
Table 372: TIMER2_GPIO2_CONF_REG (0x50010310).....	391
Table 373: TIMER2_RELOAD_REG (0x50010314).....	391
Table 374: TIMER2_SHOTWIDTH_REG (0x50010318).....	392
Table 375: TIMER2_PRESCALER_REG (0x5001031C).....	392
Table 376: TIMER2_CAPTURE_GPIO1_REG (0x50010320).....	392
Table 377: TIMER2_CAPTURE_GPIO2_REG (0x50010324).....	392
Table 378: TIMER2_PRESCALER_VAL_REG (0x50010328).....	392
Table 379: TIMER2_PWM_FREQ_REG (0x5001032C).....	392
Table 380: TIMER2_PWM_DC_REG (0x50010330).....	392
Table 381: TIMER2_CLEAR_IRQ_REG (0x50010334).....	393
Table 382: TIMER3_CTRL_REG (0x50040A00).....	393
Table 383: TIMER3_TIMER_VAL_REG (0x50040A04).....	393
Table 384: TIMER3_STATUS_REG (0x50040A08).....	393
Table 385: TIMER3_GPIO1_CONF_REG (0x50040A0C).....	394
Table 386: TIMER3_GPIO2_CONF_REG (0x50040A10).....	394
Table 387: TIMER3_RELOAD_REG (0x50040A14).....	394
Table 388: TIMER3_PRESCALER_REG (0x50040A1C).....	394
Table 389: TIMER3_CAPTURE_GPIO1_REG (0x50040A20).....	394
Table 390: TIMER3_CAPTURE_GPIO2_REG (0x50040A24).....	395
Table 391: TIMER3_PRESCALER_VAL_REG (0x50040A28).....	395
Table 392: TIMER3_PWM_FREQ_REG (0x50040A2C).....	395
Table 393: TIMER3_PWM_DC_REG (0x50040A30).....	395
Table 394: TIMER3_CLEAR_IRQ_REG (0x50040A34).....	395
Table 395: TIMER4_CTRL_REG (0x50040B00).....	395
Table 396: TIMER4_TIMER_VAL_REG (0x50040B04).....	396
Table 397: TIMER4_STATUS_REG (0x50040B08).....	396
Table 398: TIMER4_GPIO1_CONF_REG (0x50040B0C).....	396
Table 399: TIMER4_GPIO2_CONF_REG (0x50040B10).....	396
Table 400: TIMER4_RELOAD_REG (0x50040B14).....	397
Table 401: TIMER4_PRESCALER_REG (0x50040B1C).....	397
Table 402: TIMER4_CAPTURE_GPIO1_REG (0x50040B20).....	397
Table 403: TIMER4_CAPTURE_GPIO2_REG (0x50040B24).....	397
Table 404: TIMER4_PRESCALER_VAL_REG (0x50040B28).....	397
Table 405: TIMER4_PWM_FREQ_REG (0x50040B2C).....	397
Table 406: TIMER4_PWM_DC_REG (0x50040B30).....	398

Table 407: TIMER4_CLEAR_IRQ_REG (0x50040B34)	398
Table 408: Register map TRNG	398
Table 409: TRNG_CTRL_REG (0x50040C00)	398
Table 410: TRNG_FIFOLVL_REG (0x50040C04)	398
Table 411: TRNG_VER_REG (0x50040C08)	398
Table 412: Register map UART	399
Table 413: UART_RBR_THR_DLL_REG (0x50020000)	403
Table 414: UART_IER_DLH_REG (0x50020004)	404
Table 415: UART_IIR_FCR_REG (0x50020008)	405
Table 416: UART_LCR_REG (0x5002000C)	406
Table 417: UART_MCR_REG (0x50020010)	407
Table 418: UART_LSR_REG (0x50020014)	407
Table 419: UART_SCR_REG (0x5002001C)	409
Table 420: UART_SRBR_STHR0_REG (0x50020030)	409
Table 421: UART_SRBR_STHR1_REG (0x50020034)	410
Table 422: UART_SRBR_STHR2_REG (0x50020038)	410
Table 423: UART_SRBR_STHR3_REG (0x5002003C)	411
Table 424: UART_SRBR_STHR4_REG (0x50020040)	412
Table 425: UART_SRBR_STHR5_REG (0x50020044)	413
Table 426: UART_SRBR_STHR6_REG (0x50020048)	413
Table 427: UART_SRBR_STHR7_REG (0x5002004C)	414
Table 428: UART_SRBR_STHR8_REG (0x50020050)	415
Table 429: UART_SRBR_STHR9_REG (0x50020054)	415
Table 430: UART_SRBR_STHR10_REG (0x50020058)	416
Table 431: UART_SRBR_STHR11_REG (0x5002005C)	417
Table 432: UART_SRBR_STHR12_REG (0x50020060)	417
Table 433: UART_SRBR_STHR13_REG (0x50020064)	418
Table 434: UART_SRBR_STHR14_REG (0x50020068)	419
Table 435: UART_SRBR_STHR15_REG (0x5002006C)	419
Table 436: UART_USR_REG (0x5002007C)	420
Table 437: UART_TFL_REG (0x50020080)	421
Table 438: UART_RFL_REG (0x50020084)	421
Table 439: UART_SRR_REG (0x50020088)	421
Table 440: UART_SBCR_REG (0x50020090)	422
Table 441: UART_SDMAM_REG (0x50020094)	422
Table 442: UART_SFE_REG (0x50020098)	422
Table 443: UART_SRT_REG (0x5002009C)	423
Table 444: UART_STET_REG (0x500200A0)	423
Table 445: UART_HTX_REG (0x500200A4)	423
Table 446: UART_DMASA_REG (0x500200A8)	424
Table 447: UART_DLF_REG (0x500200C0)	424
Table 448: UART_UCV_REG (0x500200F8)	424
Table 449: UART_CTR_REG (0x500200FC)	424
Table 450: UART2_RBR_THR_DLL_REG (0x50020100)	424
Table 451: UART2_IER_DLH_REG (0x50020104)	425
Table 452: UART2_IIR_FCR_REG (0x50020108)	426
Table 453: UART2_LCR_REG (0x5002010C)	427
Table 454: UART2_MCR_REG (0x50020110)	428

Table 455: UART2_LSR_REG (0x50020114).....	429
Table 456: UART2_MSR_REG (0x50020118).....	431
Table 457: UART2_SCR_REG (0x5002011C).....	432
Table 458: UART2_SRBR_STHR0_REG (0x50020130).....	432
Table 459: UART2_SRBR_STHR1_REG (0x50020134).....	433
Table 460: UART2_SRBR_STHR2_REG (0x50020138).....	433
Table 461: UART2_SRBR_STHR3_REG (0x5002013C).....	434
Table 462: UART2_SRBR_STHR4_REG (0x50020140).....	435
Table 463: UART2_SRBR_STHR5_REG (0x50020144).....	435
Table 464: UART2_SRBR_STHR6_REG (0x50020148).....	436
Table 465: UART2_SRBR_STHR7_REG (0x5002014C).....	437
Table 466: UART2_SRBR_STHR8_REG (0x50020150).....	437
Table 467: UART2_SRBR_STHR9_REG (0x50020154).....	438
Table 468: UART2_SRBR_STHR10_REG (0x50020158).....	439
Table 469: UART2_SRBR_STHR11_REG (0x5002015C).....	439
Table 470: UART2_SRBR_STHR12_REG (0x50020160).....	440
Table 471: UART2_SRBR_STHR13_REG (0x50020164).....	441
Table 472: UART2_SRBR_STHR14_REG (0x50020168).....	441
Table 473: UART2_SRBR_STHR15_REG (0x5002016C).....	442
Table 474: UART2_USR_REG (0x5002017C).....	443
Table 475: UART2_TFL_REG (0x50020180).....	444
Table 476: UART2_RFL_REG (0x50020184).....	444
Table 477: UART2_SRR_REG (0x50020188).....	444
Table 478: UART2_SRTS_REG (0x5002018C).....	444
Table 479: UART2_SBCR_REG (0x50020190).....	445
Table 480: UART2_SDMAM_REG (0x50020194).....	445
Table 481: UART2_SFE_REG (0x50020198).....	446
Table 482: UART2_SRT_REG (0x5002019C).....	446
Table 483: UART2_STET_REG (0x500201A0).....	446
Table 484: UART2_HTX_REG (0x500201A4).....	447
Table 485: UART2_DMASA_REG (0x500201A8).....	447
Table 486: UART2_DLF_REG (0x500201C0).....	447
Table 487: UART2_RAR_REG (0x500201C4).....	447
Table 488: UART2_TAR_REG (0x500201C8).....	447
Table 489: UART2_LCR_EXT (0x500201CC).....	448
Table 490: UART2_UCV_REG (0x500201F8).....	449
Table 491: UART2_CTR_REG (0x500201FC).....	449
Table 492: UART3_RBR_THR_DLL_REG (0x50020200).....	449
Table 493: UART3_IER_DLH_REG (0x50020204).....	450
Table 494: UART3_IIR_FCR_REG (0x50020208).....	451
Table 495: UART3_LCR_REG (0x5002020C).....	452
Table 496: UART3_MCR_REG (0x50020210).....	453
Table 497: UART3_LSR_REG (0x50020214).....	454
Table 498: UART3_MSR_REG (0x50020218).....	456
Table 499: UART3_CONFIG_REG (0x5002021C).....	457
Table 500: UART3_SRBR_STHR0_REG (0x50020230).....	457
Table 501: UART3_SRBR_STHR1_REG (0x50020234).....	458
Table 502: UART3_SRBR_STHR2_REG (0x50020238).....	458

Table 503: UART3_SRBR_STHR3_REG (0x5002023C)	459
Table 504: UART3_SRBR_STHR4_REG (0x50020240)	460
Table 505: UART3_SRBR_STHR5_REG (0x50020244)	460
Table 506: UART3_SRBR_STHR6_REG (0x50020248)	461
Table 507: UART3_SRBR_STHR7_REG (0x5002024C)	462
Table 508: UART3_SRBR_STHR8_REG (0x50020250)	462
Table 509: UART3_SRBR_STHR9_REG (0x50020254)	463
Table 510: UART3_SRBR_STHR10_REG (0x50020258)	464
Table 511: UART3_SRBR_STHR11_REG (0x5002025C)	464
Table 512: UART3_SRBR_STHR12_REG (0x50020260)	465
Table 513: UART3_SRBR_STHR13_REG (0x50020264)	466
Table 514: UART3_SRBR_STHR14_REG (0x50020268)	466
Table 515: UART3_SRBR_STHR15_REG (0x5002026C)	467
Table 516: UART3_USR_REG (0x5002027C)	468
Table 517: UART3_TFL_REG (0x50020280)	469
Table 518: UART3_RFL_REG (0x50020284)	469
Table 519: UART3_SRR_REG (0x50020288)	469
Table 520: UART3_SRTS_REG (0x5002028C)	469
Table 521: UART3_SBCR_REG (0x50020290)	470
Table 522: UART3_SDMAM_REG (0x50020294)	470
Table 523: UART3_SFE_REG (0x50020298)	471
Table 524: UART3_SRT_REG (0x5002029C)	471
Table 525: UART3_STET_REG (0x500202A0)	471
Table 526: UART3_HTX_REG (0x500202A4)	472
Table 527: UART3_DMASA_REG (0x500202A8)	472
Table 528: UART3_DLF_REG (0x500202C0)	472
Table 529: UART3_RAR_REG (0x500202C4)	472
Table 530: UART3_TAR_REG (0x500202C8)	472
Table 531: UART3_LCR_EXT (0x500202CC)	473
Table 532: UART3_CTRL_REG (0x500202E0)	474
Table 533: UART3_TIMER_REG (0x500202E4)	474
Table 534: UART3_ERR_CTRL_REG (0x500202E8)	475
Table 535: UART3_IRQ_STATUS_REG (0x500202EC)	475
Table 536: UART3_UCV_REG (0x500202F8)	475
Table 537: UART3_CTR_REG (0x500202FC)	476
Table 538: Register map USB	476
Table 539: USB_MCTRL_REG (0x50040000)	477
Table 540: USB_XCVDIAG_REG (0x50040004)	478
Table 541: USB_TCR_REG (0x50040008)	479
Table 542: USB_UTR_REG (0x5004000C)	479
Table 543: USB_FAR_REG (0x50040010)	479
Table 544: USB_NFSR_REG (0x50040014)	480
Table 545: USB_MAEV_REG (0x50040018)	480
Table 546: USB_MAMSK_REG (0x5004001C)	481
Table 547: USB_ALTEV_REG (0x50040020)	482
Table 548: USB_ALTMSK_REG (0x50040024)	483
Table 549: USB_TXEV_REG (0x50040028)	483
Table 550: USB_TXMSK_REG (0x5004002C)	483

Table 551: USB_RXEV_REG (0x50040030)	484
Table 552: USB_RXMSK_REG (0x50040034)	484
Table 553: USB_NAKEV_REG (0x50040038)	485
Table 554: USB_NAKMSK_REG (0x5004003C)	485
Table 555: USB_FWEV_REG (0x50040040)	485
Table 556: USB_FWMSK_REG (0x50040044)	486
Table 557: USB_FNH_REG (0x50040048)	486
Table 558: USB_FNL_REG (0x5004004C)	487
Table 559: USB_UX20CDR_REG (0x5004007C)	487
Table 560: USB_EPC0_REG (0x50040080)	488
Table 561: USB_TXD0_REG (0x50040084)	488
Table 562: USB_TXS0_REG (0x50040088)	489
Table 563: USB_TXC0_REG (0x5004008C)	489
Table 564: USB_EP0_NAK_REG (0x50040090)	490
Table 565: USB_RXD0_REG (0x50040094)	490
Table 566: USB_RXS0_REG (0x50040098)	490
Table 567: USB_RXC0_REG (0x5004009C)	491
Table 568: USB_EPC1_REG (0x500400A0)	491
Table 569: USB_TXD1_REG (0x500400A4)	492
Table 570: USB_TXS1_REG (0x500400A8)	492
Table 571: USB_TXC1_REG (0x500400AC)	493
Table 572: USB_EPC2_REG (0x500400B0)	494
Table 573: USB_RXD1_REG (0x500400B4)	495
Table 574: USB_RXS1_REG (0x500400B8)	495
Table 575: USB_RXC1_REG (0x500400BC)	496
Table 576: USB_EPC3_REG (0x500400C0)	497
Table 577: USB_TXD2_REG (0x500400C4)	497
Table 578: USB_TXS2_REG (0x500400C8)	497
Table 579: USB_TXC2_REG (0x500400CC)	498
Table 580: USB_EPC4_REG (0x500400D0)	500
Table 581: USB_RXD2_REG (0x500400D4)	500
Table 582: USB_RXS2_REG (0x500400D8)	500
Table 583: USB_RXC2_REG (0x500400DC)	501
Table 584: USB_EPC5_REG (0x500400E0)	502
Table 585: USB_TXD3_REG (0x500400E4)	502
Table 586: USB_TXS3_REG (0x500400E8)	503
Table 587: USB_TXC3_REG (0x500400EC)	503
Table 588: USB_EPC6_REG (0x500400F0)	505
Table 589: USB_RXD3_REG (0x500400F4)	505
Table 590: USB_RXS3_REG (0x500400F8)	506
Table 591: USB_RXC3_REG (0x500400FC)	506
Table 592: USB_DMA_CTRL_REG (0x500401A0)	507
Table 593: USB_CHARGER_CTRL_REG (0x500401A8)	507
Table 594: USB_CHARGER_STAT_REG (0x500401AC)	508
Table 595: Register map Version	508
Table 596: CHIP_ID1_REG (0x50040200)	509
Table 597: CHIP_ID2_REG (0x50040204)	509
Table 598: CHIP_ID3_REG (0x50040208)	509

Table 599: CHIP_ID4_REG (0x5004020C).....	509
Table 600: CHIP_SWC_REG (0x50040210).....	509
Table 601: CHIP_REVISION_REG (0x50040214).....	509
Table 602: CHIP_TEST1_REG (0x500402F8).....	510
Table 603: CHIP_TEST2_REG (0x500402FC).....	510
Table 604: Register map WakeUp	510
Table 605: WKUP_CTRL_REG (0x50000100)	510
Table 606: WKUP_RESET_IRQ_REG (0x50000108)	511
Table 607: WKUP_SELECT_P0_REG (0x50000114)	511
Table 608: WKUP_SELECT_P1_REG (0x50000118)	511
Table 609: WKUP_POL_P0_REG (0x50000128)	511
Table 610: WKUP_POL_P1_REG (0x5000012C).....	511
Table 611: WKUP_STATUS_P0_REG (0x5000013C)	511
Table 612: WKUP_STATUS_P1_REG (0x50000140)	512
Table 613: WKUP_CLEAR_P0_REG (0x50000148)	512
Table 614: WKUP_CLEAR_P1_REG (0x5000014C).....	512
Table 615: WKUP_SEL_GPIO_P0_REG (0x50000154)	512
Table 616: WKUP_SEL_GPIO_P1_REG (0x50000158)	512
Table 617: Register map WDOG.....	512
Table 618: WATCHDOG_REG (0x50000700)	512
Table 619: WATCHDOG_CTRL_REG (0x50000704).....	513
Table 620: Register map GPADC	514
Table 621: SDADC_CTRL_REG (0x50020800).....	514
Table 622: SDADC_TEST_REG (0x50020808).....	515
Table 623: SDADC_GAIN_CORR_REG (0x5002080C).....	516
Table 624: SDADC_OFFS_CORR_REG (0x50020810).....	516
Table 625: SDADC_CLEAR_INT_REG (0x50020814)	516
Table 626: SDADC_RESULT_REG (0x50020818).....	516
Table 627: GP_ADC_CTRL_REG (0x50030900)	516
Table 628: GP_ADC_CTRL2_REG (0x50030904)	518
Table 629: GP_ADC_CTRL3_REG (0x50030908)	518
Table 630: GP_ADC_OFFP_REG (0x5003090C)	519
Table 631: GP_ADC_OFFN_REG (0x50030910).....	519
Table 632: GP_ADC_CLEAR_INT_REG (0x50030914).....	519
Table 633: GP_ADC_RESULT_REG (0x50030918)	519
Table 634: Register map GPIO	519
Table 635: P0_DATA_REG (0x50020A00)	521
Table 636: P1_DATA_REG (0x50020A04)	521
Table 637: P0_SET_DATA_REG (0x50020A08)	521
Table 638: P1_SET_DATA_REG (0x50020A0C).....	521
Table 639: P0_RESET_DATA_REG (0x50020A10)	522
Table 640: P1_RESET_DATA_REG (0x50020A14)	522
Table 641: P0_00_MODE_REG (0x50020A18)	522
Table 642: P0_01_MODE_REG (0x50020A1C)	523
Table 643: P0_02_MODE_REG (0x50020A20).....	524
Table 644: P0_03_MODE_REG (0x50020A24).....	524
Table 645: P0_04_MODE_REG (0x50020A28).....	524
Table 646: P0_05_MODE_REG (0x50020A2C)	525

Table 647: P0_06_MODE_REG (0x50020A30)	525
Table 648: P0_07_MODE_REG (0x50020A34)	525
Table 649: P0_08_MODE_REG (0x50020A38)	525
Table 650: P0_09_MODE_REG (0x50020A3C)	526
Table 651: P0_10_MODE_REG (0x50020A40)	526
Table 652: P0_11_MODE_REG (0x50020A44)	526
Table 653: P0_12_MODE_REG (0x50020A48)	527
Table 654: P0_13_MODE_REG (0x50020A4C)	527
Table 655: P0_14_MODE_REG (0x50020A50)	527
Table 656: P0_15_MODE_REG (0x50020A54)	527
Table 657: P0_16_MODE_REG (0x50020A58)	528
Table 658: P0_17_MODE_REG (0x50020A5C)	528
Table 659: P0_18_MODE_REG (0x50020A60)	528
Table 660: P0_19_MODE_REG (0x50020A64)	529
Table 661: P0_20_MODE_REG (0x50020A68)	529
Table 662: P0_21_MODE_REG (0x50020A6C)	529
Table 663: P0_22_MODE_REG (0x50020A70)	529
Table 664: P0_23_MODE_REG (0x50020A74)	530
Table 665: P0_24_MODE_REG (0x50020A78)	530
Table 666: P0_25_MODE_REG (0x50020A7C)	530
Table 667: P0_26_MODE_REG (0x50020A80)	531
Table 668: P0_27_MODE_REG (0x50020A84)	531
Table 669: P0_28_MODE_REG (0x50020A88)	531
Table 670: P0_29_MODE_REG (0x50020A8C)	531
Table 671: P0_30_MODE_REG (0x50020A90)	532
Table 672: P0_31_MODE_REG (0x50020A94)	532
Table 673: P1_00_MODE_REG (0x50020A98)	532
Table 674: P1_01_MODE_REG (0x50020A9C)	533
Table 675: P1_02_MODE_REG (0x50020AA0)	533
Table 676: P1_03_MODE_REG (0x50020AA4)	533
Table 677: P1_04_MODE_REG (0x50020AA8)	533
Table 678: P1_05_MODE_REG (0x50020AAC)	534
Table 679: P1_06_MODE_REG (0x50020AB0)	534
Table 680: P1_07_MODE_REG (0x50020AB4)	534
Table 681: P1_08_MODE_REG (0x50020AB8)	534
Table 682: P1_09_MODE_REG (0x50020ABC)	535
Table 683: P1_10_MODE_REG (0x50020AC0)	535
Table 684: P1_11_MODE_REG (0x50020AC4)	535
Table 685: P1_12_MODE_REG (0x50020AC8)	536
Table 686: P1_13_MODE_REG (0x50020ACC)	536
Table 687: P1_14_MODE_REG (0x50020AD0)	536
Table 688: P1_15_MODE_REG (0x50020AD4)	536
Table 689: P1_16_MODE_REG (0x50020AD8)	537
Table 690: P1_17_MODE_REG (0x50020ADC)	537
Table 691: P1_18_MODE_REG (0x50020AE0)	537
Table 692: P1_19_MODE_REG (0x50020AE4)	538
Table 693: P1_20_MODE_REG (0x50020AE8)	538
Table 694: P1_21_MODE_REG (0x50020AEC)	538

Table 695: P1_22_MODE_REG (0x50020AF0).....	538
Table 696: P0_PADPWR_CTRL_REG (0x50020AF4)	539
Table 697: P1_PADPWR_CTRL_REG (0x50020AF8)	539
Table 698: GPIO_CLK_SEL_REG (0x50020AFC)	539
Table 699: PAD_WEAK_CTRL_REG (0x50020B00).....	540
Table 700: Register map GPREG	541
Table 701: SET_FREEZE_REG (0x50040300)	541
Table 702: RESET_FREEZE_REG (0x50040304)	542
Table 703: DEBUG_REG (0x50040308).....	542
Table 704: GP_STATUS_REG (0x5004030C).....	543
Table 705: GP_CONTROL_REG (0x50040310).....	544
Table 706: USBPAD_REG (0x50040318).....	544
Table 707: Register map I2C.....	544
Table 708: I2C_CON_REG (0x50020600)	547
Table 709: I2C_TAR_REG (0x50020604).....	548
Table 710: I2C_SAR_REG (0x50020608).....	549
Table 711: I2C_HS_MADDR_REG (0x5002060C)	549
Table 712: I2C_DATA_CMD_REG (0x50020610)	550
Table 713: I2C_SS_SCL_HCNT_REG (0x50020614)	551
Table 714: I2C_SS_SCL_LCNT_REG (0x50020618).....	551
Table 715: I2C_FS_SCL_HCNT_REG (0x5002061C).....	551
Table 716: I2C_FS_SCL_LCNT_REG (0x50020620).....	551
Table 717: I2C_HS_SCL_HCNT_REG (0x50020624).....	552
Table 718: I2C_HS_SCL_LCNT_REG (0x50020628)	552
Table 719: I2C_INTR_STAT_REG (0x5002062C).....	552
Table 720: I2C_INTR_MASK_REG (0x50020630)	554
Table 721: I2C_RAW_INTR_STAT_REG (0x50020634).....	555
Table 722: I2C_RX_TL_REG (0x50020638).....	557
Table 723: I2C_TX_TL_REG (0x5002063C).....	557
Table 724: I2C_CLR_INTR_REG (0x50020640)	558
Table 725: I2C_CLR_RX_UNDER_REG (0x50020644).....	558
Table 726: I2C_CLR_RX_OVER_REG (0x50020648)	558
Table 727: I2C_CLR_TX_OVER_REG (0x5002064C)	558
Table 728: I2C_CLR_RD_REQ_REG (0x50020650).....	559
Table 729: I2C_CLR_TX_ABRT_REG (0x50020654)	559
Table 730: I2C_CLR_RX_DONE_REG (0x50020658)	559
Table 731: I2C_CLR_ACTIVITY_REG (0x5002065C).....	559
Table 732: I2C_CLR_STOP_DET_REG (0x50020660).....	559
Table 733: I2C_CLR_START_DET_REG (0x50020664).....	560
Table 734: I2C_CLR_GEN_CALL_REG (0x50020668).....	560
Table 735: I2C_ENABLE_REG (0x5002066C)	560
Table 736: I2C_STATUS_REG (0x50020670).....	561
Table 737: I2C_TXFLR_REG (0x50020674).....	562
Table 738: I2C_RXFLR_REG (0x50020678)	562
Table 739: I2C_SDA_HOLD_REG (0x5002067C).....	562
Table 740: I2C_TX_ABRT_SOURCE_REG (0x50020680)	563
Table 741: I2C_DMA_CR_REG (0x50020688).....	565
Table 742: I2C_DMA_TDLR_REG (0x5002068C).....	565

Table 743: I2C_DMA_RDLR_REG (0x50020690)	565
Table 744: I2C_SDA_SETUP_REG (0x50020694)	565
Table 745: I2C_ACK_GENERAL_CALL_REG (0x50020698)	566
Table 746: I2C_ENABLE_STATUS_REG (0x5002069C)	566
Table 747: I2C_IC_FS_SPKLEN_REG (0x500206A0)	567
Table 748: I2C_IC_HS_SPKLEN_REG (0x500206A4)	567
Table 749: I2C2_CON_REG (0x50020700)	567
Table 750: I2C2_TAR_REG (0x50020704)	569
Table 751: I2C2_SAR_REG (0x50020708)	570
Table 752: I2C2_HS_MADDR_REG (0x5002070C)	570
Table 753: I2C2_DATA_CMD_REG (0x50020710)	570
Table 754: I2C2_SS_SCL_HCNT_REG (0x50020714)	571
Table 755: I2C2_SS_SCL_LCNT_REG (0x50020718)	571
Table 756: I2C2_FS_SCL_HCNT_REG (0x5002071C)	572
Table 757: I2C2_FS_SCL_LCNT_REG (0x50020720)	572
Table 758: I2C2_HS_SCL_HCNT_REG (0x50020724)	572
Table 759: I2C2_HS_SCL_LCNT_REG (0x50020728)	572
Table 760: I2C2_INTR_STAT_REG (0x5002072C)	573
Table 761: I2C2_INTR_MASK_REG (0x50020730)	575
Table 762: I2C2_RAW_INTR_STAT_REG (0x50020734)	576
Table 763: I2C2_RX_TL_REG (0x50020738)	578
Table 764: I2C2_TX_TL_REG (0x5002073C)	578
Table 765: I2C2_CLR_INTR_REG (0x50020740)	578
Table 766: I2C2_CLR_RX_UNDER_REG (0x50020744)	578
Table 767: I2C2_CLR_RX_OVER_REG (0x50020748)	579
Table 768: I2C2_CLR_TX_OVER_REG (0x5002074C)	579
Table 769: I2C2_CLR_RD_REQ_REG (0x50020750)	579
Table 770: I2C2_CLR_TX_ABRT_REG (0x50020754)	579
Table 771: I2C2_CLR_RX_DONE_REG (0x50020758)	580
Table 772: I2C2_CLR_ACTIVITY_REG (0x5002075C)	580
Table 773: I2C2_CLR_STOP_DET_REG (0x50020760)	580
Table 774: I2C2_CLR_START_DET_REG (0x50020764)	580
Table 775: I2C2_CLR_GEN_CALL_REG (0x50020768)	580
Table 776: I2C2_ENABLE_REG (0x5002076C)	581
Table 777: I2C2_STATUS_REG (0x50020770)	581
Table 778: I2C2_TXFLR_REG (0x50020774)	583
Table 779: I2C2_RXFLR_REG (0x50020778)	583
Table 780: I2C2_SDA_HOLD_REG (0x5002077C)	583
Table 781: I2C2_TX_ABRT_SOURCE_REG (0x50020780)	583
Table 782: I2C2_DMA_CR_REG (0x50020788)	585
Table 783: I2C2_DMA_TDLR_REG (0x5002078C)	586
Table 784: I2C2_DMA_RDLR_REG (0x50020790)	586
Table 785: I2C2_SDA_SETUP_REG (0x50020794)	586
Table 786: I2C2_ACK_GENERAL_CALL_REG (0x50020798)	586
Table 787: I2C2_ENABLE_STATUS_REG (0x5002079C)	586
Table 788: I2C2_IC_FS_SPKLEN_REG (0x500207A0)	587
Table 789: I2C2_IC_HS_SPKLEN_REG (0x500207A4)	588
Table 790: Register map PDC	588

Table 791: PDC_CTRL0_REG (0x50000200).....	589
Table 792: PDC_CTRL1_REG (0x50000204).....	590
Table 793: PDC_CTRL2_REG (0x50000208).....	590
Table 794: PDC_CTRL3_REG (0x5000020C).....	590
Table 795: PDC_CTRL4_REG (0x50000210).....	591
Table 796: PDC_CTRL5_REG (0x50000214).....	591
Table 797: PDC_CTRL6_REG (0x50000218).....	591
Table 798: PDC_CTRL7_REG (0x5000021C).....	592
Table 799: PDC_CTRL8_REG (0x50000220).....	592
Table 800: PDC_CTRL9_REG (0x50000224).....	592
Table 801: PDC_CTRL10_REG (0x50000228).....	593
Table 802: PDC_CTRL11_REG (0x5000022C).....	593
Table 803: PDC_CTRL12_REG (0x50000230).....	594
Table 804: PDC_CTRL13_REG (0x50000234).....	594
Table 805: PDC_CTRL14_REG (0x50000238).....	594
Table 806: PDC_CTRL15_REG (0x5000023C).....	595
Table 807: PDC_ACKNOWLEDGE_REG (0x50000280)	595
Table 808: PDC_PENDING_REG (0x50000284).....	595
Table 809: PDC_PENDING_SNC_REG (0x50000288).....	595
Table 810: PDC_PENDING_CM33_REG (0x5000028C)	595
Table 811: PDC_PENDING_CMAC_REG (0x50000290).....	595
Table 812: PDC_SET_PENDING_REG (0x50000294)	596
Table 813: Register map DCDC	596
Table 814: DCDC_CTRL1_REG (0x50000304).....	596
Table 815: DCDC_CTRL2_REG (0x50000308).....	597
Table 816: DCDC_V14_REG (0x5000030C)	597
Table 817: DCDC_VDD_REG (0x50000310).....	598
Table 818: DCDC_V18_REG (0x50000314).....	599
Table 819: DCDC_V18P_REG (0x50000318)	599
Table 820: DCDC_STATUS1_REG (0x50000320).....	600
Table 821: DCDC_IRQ_STATUS_REG (0x50000330)	601
Table 822: DCDC_IRQ_CLEAR_REG (0x50000334).....	601
Table 823: DCDC_IRQ_MASK_REG (0x50000338)	602
Table 824: Register map DMA	602
Table 825: DMA0_A_START_REG (0x50040800)	603
Table 826: DMA0_B_START_REG (0x50040804)	604
Table 827: DMA0_INT_REG (0x50040808).....	604
Table 828: DMA0_LEN_REG (0x5004080C).....	604
Table 829: DMA0_CTRL_REG (0x50040810)	604
Table 830: DMA0_IDX_REG (0x50040814).....	606
Table 831: DMA1_A_START_REG (0x50040820)	606
Table 832: DMA1_B_START_REG (0x50040824)	606
Table 833: DMA1_INT_REG (0x50040828).....	606
Table 834: DMA1_LEN_REG (0x5004082C).....	607
Table 835: DMA1_CTRL_REG (0x50040830)	607
Table 836: DMA1_IDX_REG (0x50040834).....	608
Table 837: DMA2_A_START_REG (0x50040840)	609
Table 838: DMA2_B_START_REG (0x50040844)	609

Table 839: DMA2_INT_REG (0x50040848).....	609
Table 840: DMA2_LEN_REG (0x5004084C).....	609
Table 841: DMA2_CTRL_REG (0x50040850).....	609
Table 842: DMA2_IDX_REG (0x50040854).....	611
Table 843: DMA3_A_START_REG (0x50040860).....	611
Table 844: DMA3_B_START_REG (0x50040864).....	612
Table 845: DMA3_INT_REG (0x50040868).....	612
Table 846: DMA3_LEN_REG (0x5004086C).....	612
Table 847: DMA3_CTRL_REG (0x50040870).....	612
Table 848: DMA3_IDX_REG (0x50040874).....	614
Table 849: DMA4_A_START_REG (0x50040880).....	614
Table 850: DMA4_B_START_REG (0x50040884).....	614
Table 851: DMA4_INT_REG (0x50040888).....	614
Table 852: DMA4_LEN_REG (0x5004088C).....	615
Table 853: DMA4_CTRL_REG (0x50040890).....	615
Table 854: DMA4_IDX_REG (0x50040894).....	616
Table 855: DMA5_A_START_REG (0x500408A0).....	617
Table 856: DMA5_B_START_REG (0x500408A4).....	617
Table 857: DMA5_INT_REG (0x500408A8).....	617
Table 858: DMA5_LEN_REG (0x500408AC).....	617
Table 859: DMA5_CTRL_REG (0x500408B0).....	617
Table 860: DMA5_IDX_REG (0x500408B4).....	619
Table 861: DMA6_A_START_REG (0x500408C0).....	619
Table 862: DMA6_B_START_REG (0x500408C4).....	620
Table 863: DMA6_INT_REG (0x500408C8).....	620
Table 864: DMA6_LEN_REG (0x500408CC).....	620
Table 865: DMA6_CTRL_REG (0x500408D0).....	620
Table 866: DMA6_IDX_REG (0x500408D4).....	622
Table 867: DMA7_A_START_REG (0x500408E0).....	622
Table 868: DMA7_B_START_REG (0x500408E4).....	622
Table 869: DMA7_INT_REG (0x500408E8).....	622
Table 870: DMA7_LEN_REG (0x500408EC).....	623
Table 871: DMA7_CTRL_REG (0x500408F0).....	623
Table 872: DMA7_IDX_REG (0x500408F4).....	625
Table 873: DMA_REQ_MUX_REG (0x50040900).....	625
Table 874: DMA_INT_STATUS_REG (0x50040904).....	626
Table 875: DMA_CLEAR_INT_REG (0x50040908).....	627
Table 876: DMA_INT_MASK_REG (0x5004090C).....	628
Table 877: Register map CHARGER.....	629
Table 878: CHARGER_CTRL_REG (0x50040400).....	630
Table 879: CHARGER_TEST_CTRL_REG (0x50040404).....	634
Table 880: CHARGER_STATUS_REG (0x50040408).....	634
Table 881: CHARGER_VOLTAGE_PARAM_REG (0x5004040C).....	639
Table 882: CHARGER_CURRENT_PARAM_REG (0x50040410).....	642
Table 883: CHARGER_TEMPSET_PARAM_REG (0x50040414).....	645
Table 884: CHARGER_PRE_CHARGE_TIMER_REG (0x50040418).....	647
Table 885: CHARGER_CC_CHARGE_TIMER_REG (0x5004041C).....	648
Table 886: CHARGER_CV_CHARGE_TIMER_REG (0x50040420).....	648

Table 887: CHARGER_TOTAL_CHARGE_TIMER_REG (0x50040424)	649
Table 888: CHARGER_JEITA_V_CHARGE_REG (0x50040428)	649
Table 889: CHARGER_JEITA_V_PRECHARGE_REG (0x5004042C)	649
Table 890: CHARGER_JEITA_V_REPLENISH_REG (0x50040430)	650
Table 891: CHARGER_JEITA_V_OVP_REG (0x50040434)	650
Table 892: CHARGER_JEITA_CURRENT_REG (0x50040438)	650
Table 893: CHARGER_VBAT_COMP_TIMER_REG (0x5004043C)	650
Table 894: CHARGER_VOVP_COMP_TIMER_REG (0x50040440)	651
Table 895: CHARGER_TDIE_COMP_TIMER_REG (0x50040444)	652
Table 896: CHARGER_TBAT_MON_TIMER_REG (0x50040448)	652
Table 897: CHARGER_TBAT_COMP_TIMER_REG (0x5004044C)	653
Table 898: CHARGER_THOT_COMP_TIMER_REG (0x50040450)	653
Table 899: CHARGER_PWR_UP_TIMER_REG (0x50040454)	653
Table 900: CHARGER_STATE_IRQ_MASK_REG (0x50040458)	654
Table 901: CHARGER_ERROR_IRQ_MASK_REG (0x5004045C)	655
Table 902: CHARGER_STATE_IRQ_STATUS_REG (0x50040460)	656
Table 903: CHARGER_ERROR_IRQ_STATUS_REG (0x50040464)	657
Table 904: CHARGER_STATE_IRQ_CLR_REG (0x50040468)	658
Table 905: CHARGER_ERROR_IRQ_CLR_REG (0x5004046C)	659
Table 906: Register map CRG	659
Table 907: CLK_AMBA_REG (0x50000000)	661
Table 908: CLK_RADIO_REG (0x50000010)	662
Table 909: CLK_CTRL_REG (0x50000014)	662
Table 910: CLK_TMR_REG (0x50000018)	663
Table 911: CLK_SWITCH2XTAL_REG (0x5000001C)	663
Table 912: PMU_CTRL_REG (0x50000020)	664
Table 913: SYS_CTRL_REG (0x50000024)	664
Table 914: SYS_STAT_REG (0x50000028)	665
Table 915: CLK_RC32K_REG (0x5000003C)	666
Table 916: CLK_XTAL32K_REG (0x50000040)	666
Table 917: CLK_RC32M_REG (0x50000044)	667
Table 918: CLK_RCX_REG (0x50000048)	668
Table 919: CLK_RTCDIV_REG (0x5000004C)	668
Table 920: BANDGAP_REG (0x50000050)	668
Table 921: VBUS_IRQ_MASK_REG (0x50000054)	669
Table 922: VBUS_IRQ_CLEAR_REG (0x50000058)	669
Table 923: BOD_CTRL_REG (0x50000060)	669
Table 924: BOD_LVL_CTRL0_REG (0x50000064)	670
Table 925: BOD_LVL_CTRL1_REG (0x50000068)	670
Table 926: BOD_LVL_CTRL2_REG (0x5000006C)	671
Table 927: P0_PAD_LATCH_REG (0x50000070)	671
Table 928: P0_SET_PAD_LATCH_REG (0x50000074)	671
Table 929: P0_RESET_PAD_LATCH_REG (0x50000078)	671
Table 930: P1_PAD_LATCH_REG (0x5000007C)	671
Table 931: P1_SET_PAD_LATCH_REG (0x50000080)	672
Table 932: P1_RESET_PAD_LATCH_REG (0x50000084)	672
Table 933: BOD_STATUS_REG (0x50000090)	672
Table 934: POR_VBAT_CTRL_REG (0x50000094)	673

Table 935: POR_PIN_REG (0x50000098).....	674
Table 936: POR_TIMER_REG (0x5000009C).....	674
Table 937: LDO_VDDD_HIGH_CTRL_REG (0x500000A0).....	674
Table 938: BIAS_VREF_SEL_REG (0x500000A4).....	675
Table 939: RESET_STAT_REG (0x500000BC).....	675
Table 940: RAM_PWR_CTRL_REG (0x500000C0).....	676
Table 941: SECURE_BOOT_REG (0x500000CC).....	676
Table 942: DISCHARGE_RAIL_REG (0x500000D4).....	677
Table 943: ANA_STATUS_REG (0x500000EC).....	678
Table 944: POWER_CTRL_REG (0x500000F0).....	678
Table 945: PMU_SLEEP_REG (0x500000F4).....	681
Table 946: PMU_TRIM_REG (0x500000F8).....	681
Table 947: CLK_FREQ_TRIM_REG (0x50010000).....	681
Table 948: TRIM_CTRL_REG (0x50010010).....	682
Table 949: XTALRDY_CTRL_REG (0x50010018).....	682
Table 950: XTALRDY_STAT_REG (0x5001001C).....	683
Table 951: XTAL32M_CTRL0_REG (0x50010030).....	683
Table 952: XTAL32M_CTRL1_REG (0x50010034).....	684
Table 953: XTAL32M_CTRL2_REG (0x50010038).....	685
Table 954: XTAL32M_CTRL3_REG (0x5001003C).....	686
Table 955: XTAL32M_STAT0_REG (0x50010050).....	687
Table 956: XTAL32M_STAT1_REG (0x50010054).....	687
Table 957: PLL_SYS_CTRL1_REG (0x50010060).....	688
Table 958: PLL_SYS_CTRL2_REG (0x50010064).....	689
Table 959: PLL_SYS_CTRL3_REG (0x50010068).....	689
Table 960: PLL_SYS_STATUS_REG (0x50010070).....	690
Table 961: CLK_COM_REG (0x50020904).....	690
Table 962: SET_CLK_COM_REG (0x50020908).....	692
Table 963: RESET_CLK_COM_REG (0x5002090C).....	693
Table 964: CLK_PER_REG (0x50030C04).....	694
Table 965: SET_CLK_PER_REG (0x50030C08).....	695
Table 966: RESET_CLK_PER_REG (0x50030C0C).....	695
Table 967: PCM_DIV_REG (0x50030C40).....	696
Table 968: PCM_FDIV_REG (0x50030C44).....	696
Table 969: PDM_DIV_REG (0x50030C48).....	696
Table 970: SRC_DIV_REG (0x50030C4C).....	697
Table 971: CLK_SYS_REG (0x50040500).....	697
Table 972: BATCHECK_REG (0x50040504).....	697
Table 973: Register map CACHE.....	698
Table 974: CACHE_CTRL1_REG (0x100C0000).....	698
Table 975: CACHE_LNSIZECFG_REG (0x100C0004).....	698
Table 976: CACHE ASSOCCFG_REG (0x100C0008).....	699
Table 977: CACHE_CTRL2_REG (0x100C0020).....	699
Table 978: CACHE_MRM_HITS_REG (0x100C0028).....	699
Table 979: CACHE_MRM_MISSES_REG (0x100C002C).....	700
Table 980: CACHE_MRM_CTRL_REG (0x100C0030).....	700
Table 981: CACHE_MRM_TINT_REG (0x100C0034).....	700
Table 982: CACHE_MRM_MISSES_THRES_REG (0x100C0038).....	701

Table 983: CACHE_MRM_HITS_THRES_REG (0x100C003C).....	701
Table 984: CACHE_FLASH_REG (0x100C0040).....	701
Table 985: SWD_RESET_REG (0x100C0050).....	702
Table 986: Register map APU.....	702
Table 987: SRC1_CTRL_REG (0x50030600).....	703
Table 988: SRC1_IN_FS_REG (0x50030604).....	704
Table 989: SRC1_OUT_FS_REG (0x50030608).....	705
Table 990: SRC1_IN1_REG (0x5003060C).....	706
Table 991: SRC1_IN2_REG (0x50030610).....	706
Table 992: SRC1_OUT1_REG (0x50030614).....	706
Table 993: SRC1_OUT2_REG (0x50030618).....	706
Table 994: APU_MUX_REG (0x5003061C).....	706
Table 995: COEF10_SET1_REG (0x50030620).....	706
Table 996: COEF32_SET1_REG (0x50030624).....	707
Table 997: COEF54_SET1_REG (0x50030628).....	707
Table 998: COEF76_SET1_REG (0x5003062C).....	707
Table 999: COEF98_SET1_REG (0x50030630).....	707
Table 1000: COEF0A_SET1_REG (0x50030634).....	707
Table 1001: PCM1_CTRL_REG (0x50030700).....	707
Table 1002: PCM1_IN1_REG (0x50030704).....	708
Table 1003: PCM1_IN2_REG (0x50030708).....	708
Table 1004: PCM1_OUT1_REG (0x5003070C).....	708
Table 1005: PCM1_OUT2_REG (0x50030710).....	708
Table 1006: Register map ANAMISC.....	708
Table 1007: CLK_REF_SEL_REG (0x50030B10).....	709
Table 1008: CLK_REF_CNT_REG (0x50030B14).....	709
Table 1009: CLK_REF_VAL_REG (0x50030B18).....	709
Table 1010: Register map AES_HASH.....	709
Table 1011: CRYPTO_CTRL_REG (0x30040000).....	710
Table 1012: CRYPTO_START_REG (0x30040004).....	712
Table 1013: CRYPTO_FETCH_ADDR_REG (0x30040008).....	712
Table 1014: CRYPTO_LEN_REG (0x3004000C).....	712
Table 1015: CRYPTO_DEST_ADDR_REG (0x30040010).....	712
Table 1016: CRYPTO_STATUS_REG (0x30040014).....	712
Table 1017: CRYPTO_CLRIRQ_REG (0x30040018).....	713
Table 1018: CRYPTO_MREG0_REG (0x3004001C).....	713
Table 1019: CRYPTO_MREG1_REG (0x30040020).....	713
Table 1020: CRYPTO_MREG2_REG (0x30040024).....	713
Table 1021: CRYPTO_MREG3_REG (0x30040028).....	713
Table 1022: CRYPTO_KEYS_START (0x30040100).....	714
Table 1023: Ordering information (samples/production).....	714
Table 1024: Ordering information (custom).....	714

1. Block Diagram

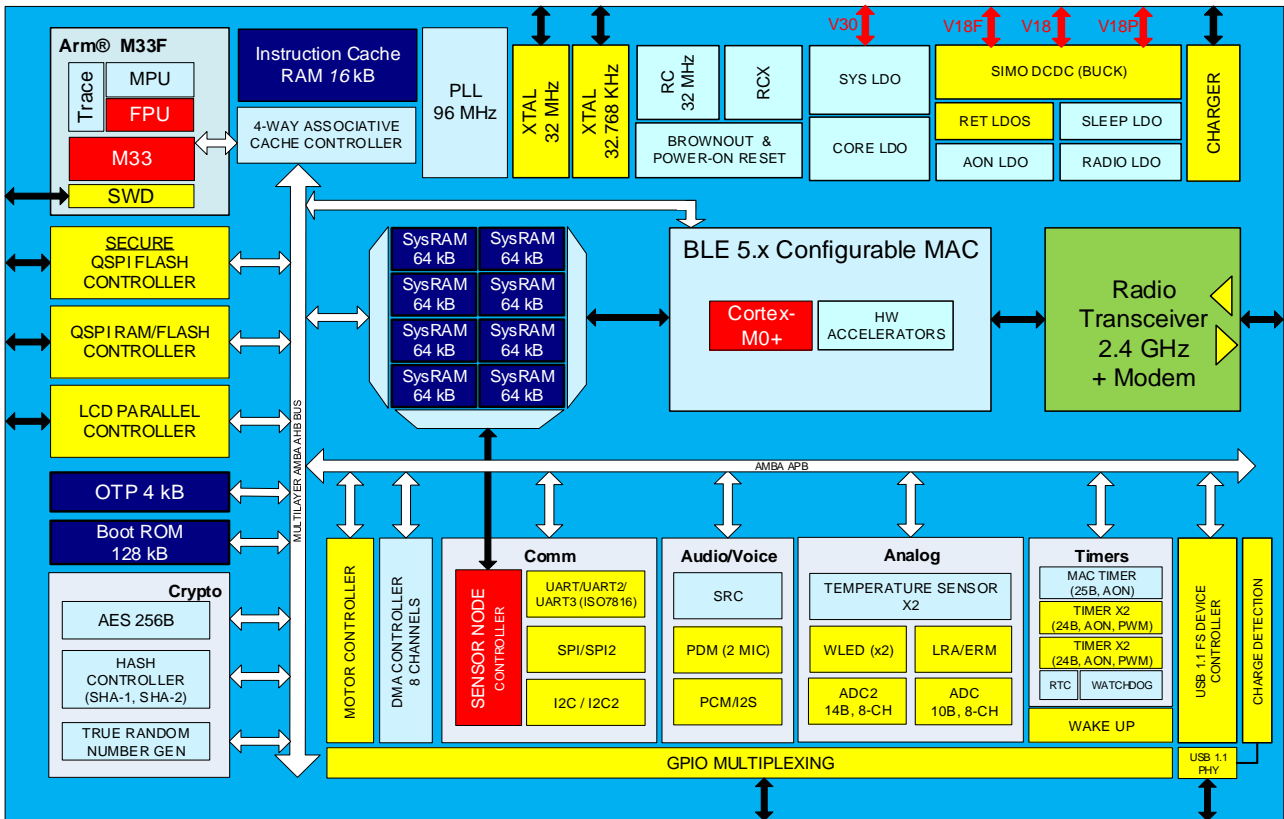

Figure 1. DA1469x block diagram

2. Application Information

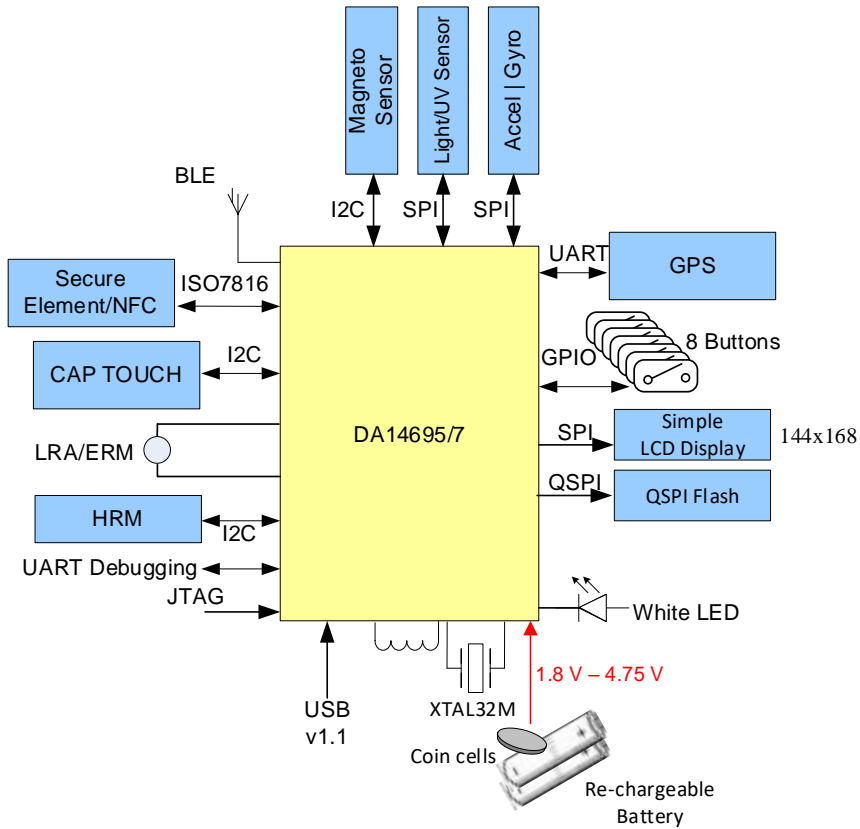

Figure 2. Activity tracker

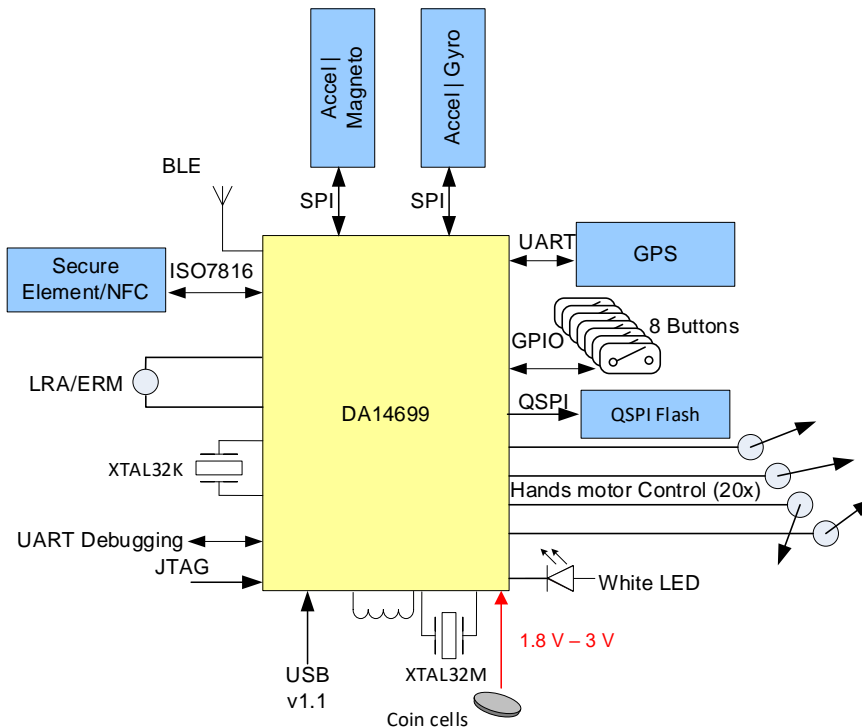

Figure 3. Analog watch

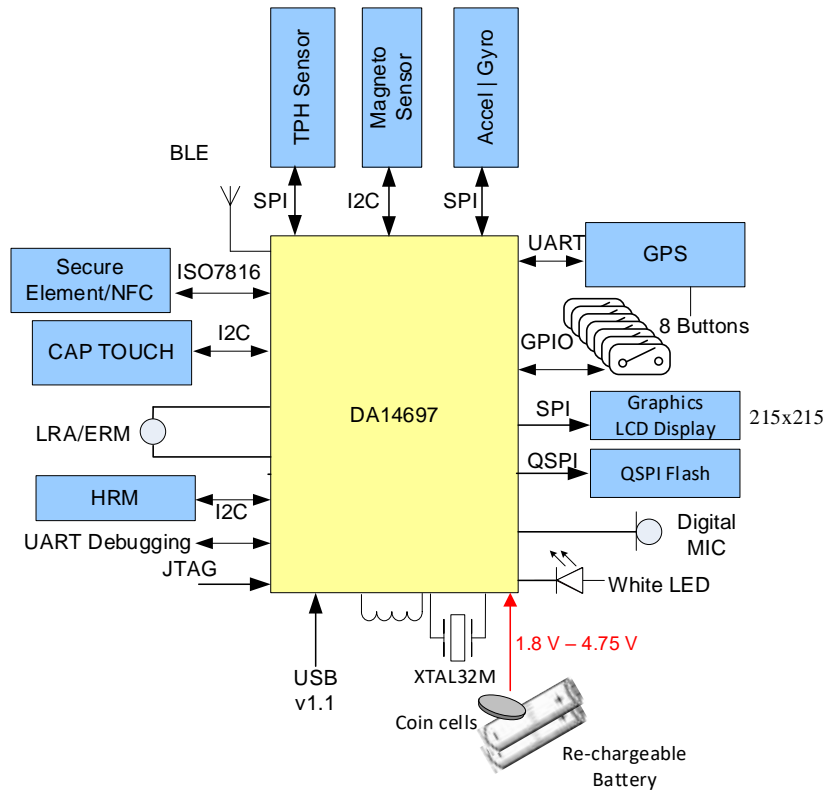

Figure 4. Sport watch

NOTE

All the external components are directly powered by the DA1469x Power Management Unit (PMU).

3. DA1469x Product Family

Table 1 presents the differentiation between the members of the DA1469x product family.

Table 1: DA1469x product family differentiation

Features	DA14691	DA14695	DA14697	DA14699
Available RAM	384 kB	512 kB	512 kB	512 kB
Charger	x	✓	✓	✓
LCD Controller	x	✓	✓	✓
Haptics Controller	x	x	✓	✓
LEDs	x	x	✓	✓
QSPI RAM Controller	x	✓	✓	✓
Motor Controller	x	x	x	✓
GPIOs (P1_12 to P1_22)	x	x	✓	✓
Rest of the features	✓	✓	✓	✓
Package	VFBGA86	VFBGA86	VFBGA100	VFBGA100

4. Pinout

The DA1469x comes in two packages:

- A 6 mm x 6 mm VFBGA with 86 balls
- A 5 mm x 5 mm VFBGA with 100 balls

The actual pin/ball assignment is depicted in the following sections.

4.1 VFBGA86 Pinout

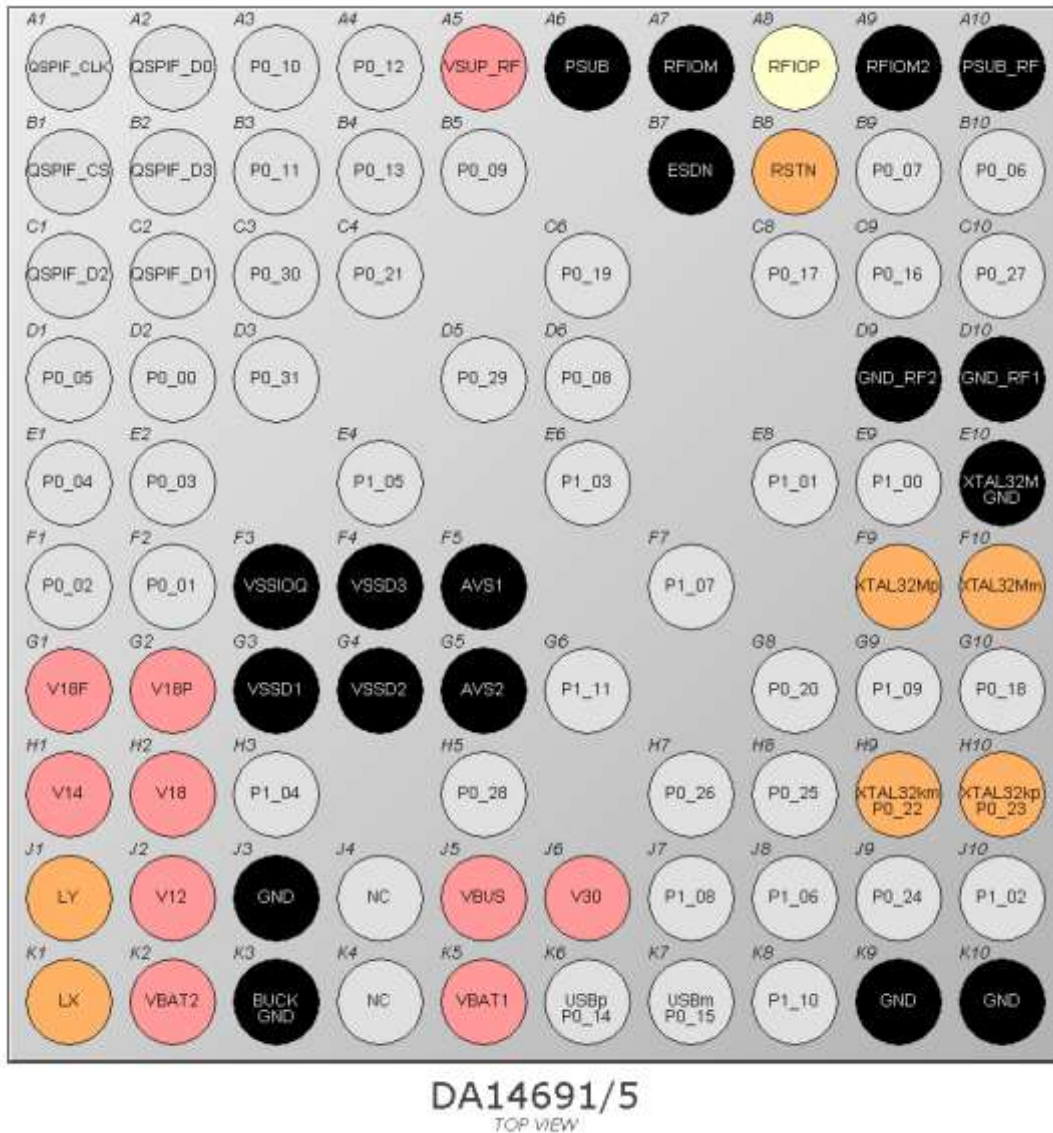

Legend: Digital (grey), Analog (orange), Radio (yellow), Power (red), GND (black)

Figure 5. VFBGA86 ball assignment

Table 2: DA14691/5 pin description

Ball No.	Pin name	Type	Drive (mA)	Reset state	Description
General Purpose I/Os (fixed pin assignment; additional functions are programmable through Px_xx_MODE_REG)					

Ball No.	Pin name	Type	Drive (mA)	Reset state	Description
D2	P0_00 QSPIR_D0	DIO DIO	4/8/12/16	I-PD	INPUT/OUTPUT with selectable pull up/down resistor and open drain functionality. Pull-down enabled during and after reset. General-purpose I/O port bit or alternate function nodes. Contains state retention mechanism during power down. (Note 5) INPUT/OUTPUT. QSPI RAM data I/O 0.
F2	P0_01 QSPIR_D1	DIO DIO	4/8/12/16	I-PD	INPUT/OUTPUT with selectable pull up/down resistor and open drain functionality. Pull-down enabled during and after reset. General-purpose I/O port bit or alternate function nodes. Contains state retention mechanism during power down. (Note 5) INPUT/OUTPUT. QSPI RAM data I/O 1.
F1	P0_02 QSPIR_D2	DIO DIO	4/8/12/16	I-PD	INPUT/OUTPUT with selectable pull up/down resistor and open drain functionality. Pull-down enabled during and after reset. General-purpose I/O port bit or alternate function nodes. Contains state retention mechanism during power down. (Note 5) INPUT/OUTPUT. QSPI RAM data I/O 2.
E2	P0_03 QSPIR_D3	DIO DIO	4/8/12/16	I-PD	INPUT/OUTPUT with selectable pull up/down resistor and open drain functionality. Pull-down enabled during and after reset. General-purpose I/O port bit or alternate function nodes. Contains state retention mechanism during power down. (Note 5) INPUT/OUTPUT. QSPI RAM data I/O 3.
E1	P0_04 QSPIR_CS	DIO DO	4/8/12/16	I-PU	INPUT/OUTPUT with selectable pull up/down resistor and open drain functionality. Pull-down enabled during and after reset. General-purpose I/O port bit or alternate function nodes. Contains state retention mechanism during power down. (Note 5) OUTPUT. QSPI RAM chip select (active LOW).
D1	P0_05 QSPIR_CLK	DIO DO	4/8/12/16	I-PD	INPUT/OUTPUT with selectable pull up/down resistor and open drain functionality. Pull-down enabled during and after reset. General-purpose I/O port bit or alternate function nodes. Contains state retention mechanism during power down. (Note 5) OUTPUT. QSPI RAM clock.
B10	P0_06 SDADC_GND	DIO/ RDS AI	4.8/ 0.15 (Note 4)	I-PD	INPUT/OUTPUT with selectable pull up/down resistor and open drain functionality. Pull-down enabled during and after reset. General-purpose I/O port bit or alternate function nodes. Contains state retention mechanism during power down. INPUT. Analog input for the $\Sigma\Delta$ ADC reference ground.
B9	P0_07 NTC Input	DIO/ RDS AI	4.8/ 0.15	I-PD	INPUT/OUTPUT with selectable pull up/down resistor and open drain functionality. Pull-down enabled during and after reset. General-purpose I/O port bit or alternate function nodes. Contains state retention mechanism during power down. INPUT. Analog input for battery NTC (feedback).
D6	P0_08 GPADC_2	DIO AI	4.8	I-PD	INPUT/OUTPUT with selectable pull up/down resistor and open drain functionality. Pull-down enabled during and after reset. General-purpose I/O port bit or alternate function nodes. Contains state retention mechanism during power down. INPUT. Analog input for the general-purpose ADC, channel 2.

Multi-Core Bluetooth 5.2 SoC Family with System PMU

Ball No.	Pin name	Type	Drive (mA)	Reset state	Description
	SDADC_2 UART Boot RX	AI DI			INPUT. Analog input for the $\Sigma\Delta$ ADC, channel 2. INPUT. UART Receive data input during boot.
B5	P0_09 GPADC_3 SDADC_3 UART Boot TX	DIO AI AI DO	4.8	I-PD	INPUT/OUTPUT with selectable pull up/down resistor and open drain functionality. Pull-down enabled during and after reset. General-purpose I/O port bit or alternate function nodes. Contains state retention mechanism during power down. INPUT. Analog input for the general-purpose ADC, channel 3 INPUT. Analog input for the $\Sigma\Delta$ ADC, channel 3. OUTPUT. UART Transmit data output during boot.
A3	P0_10 M33_SWDIO	DIO DIO	4.8	I-PU	INPUT/OUTPUT with selectable pull up/down resistor and open drain functionality. Pull-down enabled during and after reset. General-purpose I/O port bit or alternate function nodes. Contains state retention mechanism during power down. INPUT/OUTPUT. Arm Cortex-M33 JTAG data I/O signal.
B3	P0_11 M33_SWCLK	DIO DI	4.8	I-PD	INPUT/OUTPUT with selectable pull up/down resistor and open drain functionality. Pull-down enabled during and after reset. General-purpose I/O port bit or alternate function nodes. Contains state retention mechanism during power down. INPUT. Arm Cortex-M33 JTAG clock signal.
A4	P0_12 CMAC_SWDIO XTAL32M	DIO DIO DO	4.8	I-PU	INPUT/OUTPUT with selectable pull up/down resistor and open drain functionality. Pull-down enabled during and after reset. General-purpose I/O port bit or alternate function nodes. Contains state retention mechanism during power down. INPUT/OUTPUT. Arm Cortex-M0+ JTAG data I/O signal. OUTPUT. XTAL32MHz oscillator clock
B4	P0_13 CMAC_SWCLK RC32M	DIO DI DO	4.8	I-PD	INPUT/OUTPUT with selectable pull up/down resistor and open drain functionality. Pull-down enabled during and after reset. General-purpose I/O port bit or alternate function nodes. Contains state retention mechanism during power down. INPUT. Arm Cortex-M0+ JTAG clock signal. OUTPUT. RC32M clock signal output (square wave).
K6	P0_14 USBp XTAL32k	DIO AIO DO	4.8	I-PD	INPUT/OUTPUT with selectable pull up/down resistor and open drain functionality. Pull-down enabled during and after reset. General-purpose I/O port bit or alternate function nodes. Does not contain state retention mechanism during power down. INPUT/OUTPUT. Analog USB Full Speed D+ signal. OUTPUT. XTAL32k clock signal output (square wave).
K7	P0_15 USBm DIVN	DIO AIO DO	4.8	I-PD	INPUT/OUTPUT with selectable pull up/down resistor and open drain functionality. Pull-down enabled during and after reset. General-purpose I/O port bit or alternate function nodes. Does not contain state retention mechanism during power down. INPUT/OUTPUT. Analog USB Full Speed D- signal. OUTPUT. DIVN clock signal output (square wave).
C9	P0_16	DIO/ RDS	4.8/ 0.15	I-PD	INPUT/OUTPUT with selectable pull up/down resistor and open drain functionality. Pull-down enabled during and after reset. General-purpose I/O port bit or alternate

Ball No.	Pin name	Type	Drive (mA)	Reset state	Description
	SDADC_REF RCX	AI DO			function nodes. Contains state retention mechanism during power down. INPUT. Analog input for the $\Sigma\Delta$ ADC reference voltage. OUTPUT. RCX clock signal output (square wave).
C8	P0_17 RC32k	DIO/ RDS DO	4.8/ 0.15	I-PD	INPUT/OUTPUT with selectable pull up/down resistor and open drain functionality. Pull-down enabled during and after reset. General-purpose I/O port bit or alternate function nodes. Contains state retention mechanism during power down. OUTPUT. RC32k clock signal output (square wave).
G10	P0_18	DIO/ RDS	4.8/ 0.15	I-PD	INPUT/OUTPUT with selectable pull up/down resistor and open drain functionality. Pull-down enabled during and after reset. General-purpose I/O port bit or alternate function nodes. Contains state retention mechanism during power down.
C6	P0_19	DIO	4.8	I-PD	INPUT/OUTPUT with selectable pull up/down resistor and open drain functionality. Pull-down enabled during and after reset. General-purpose I/O port bit or alternate function nodes. Contains state retention mechanism during power down.
G8	P0_20	DIO	4.8	I-PD	INPUT/OUTPUT with selectable pull up/down resistor and open drain functionality. Pull-down enabled during and after reset. General-purpose I/O port bit or alternate function nodes. Contains state retention mechanism during power down.
C4	P0_21	DIO	4.8	I-PD	INPUT/OUTPUT with selectable pull up/down resistor and open drain functionality. Pull-down enabled during and after reset. General-purpose I/O port bit or alternate function nodes. Contains state retention mechanism during power down.
H9	P0_22 XTAL32km	DIO AO	4.8	I-PD	INPUT/OUTPUT with selectable pull up/down resistor and open drain functionality. Pull-down enabled during and after reset. General-purpose I/O port bit or alternate function nodes. Contains state retention mechanism during power down. OUTPUT. Analog output of the XTAL32K crystal oscillator.
H10	P0_23 XTAL32kp	DIO AI DI	4.8	I-PD	INPUT/OUTPUT with selectable pull up/down resistor and open drain functionality. Pull-down enabled during and after reset. General-purpose I/O port bit or alternate function nodes. Contains state retention mechanism during power down. INPUT. Analog input of the XTAL32K crystal oscillator. INPUT. Digital input for an external clock (square wave).
J9	P0_24 LCD_TE	DIO DI	4.8	I-PD	INPUT/OUTPUT with selectable pull up/down resistor and open drain functionality. Pull-down enabled during and after reset. General-purpose I/O port bit or alternate function nodes. Contains state retention mechanism during power down. INPUT. LCD Tearing effect signal. Used to synchronize the CPU to the frame memory writing.
H8	P0_25	DIO/ RDS	4.8/ 0.15	I-PD	INPUT/OUTPUT with selectable pull up/down resistor and open drain functionality. Pull-down enabled during and after reset. General-purpose I/O port bit or alternate function nodes. Contains state retention mechanism during power down.

Multi-Core Bluetooth 5.2 SoC Family with System PMU

Ball No.	Pin name	Type	Drive (mA)	Reset state	Description
	GPADC_1	AI			INPUT. Analog input for the general-purpose ADC, channel 1.
	SDADC_1	AI			INPUT. Analog input for the $\Sigma\Delta$ ADC, channel 1.
H7	P0_26	DIO/ RDS	4.8/ 0.15	I-PD	INPUT/OUTPUT with selectable pull up/down resistor and open drain functionality. Pull-down enabled during and after reset. General-purpose I/O port bit or alternate function nodes. Contains state retention mechanism during power down.
	LCD_VCK	DO			OUTPUT. LCD Shift clock for the vertical driver.
C10	P0_27	DIO/ RDS	4.8/ 0.15	I-PD	INPUT/OUTPUT with selectable pull up/down resistor and open drain functionality. Pull-down enabled during and after reset. General-purpose I/O port bit or alternate function nodes. Contains state retention mechanism during power down.
	LCD_ENB	DO			OUTPUT. LCD Write enable signal for the pixel memory.
	PLCD_ENAB	DO			OUTPUT. Parallel LCD Indication signal for valid data on the LCD data bus.
H5	P0_28	DIO	4.8	I-PD	INPUT/OUTPUT with selectable pull up/down resistor and open drain functionality. Pull-down enabled during and after reset. General-purpose I/O port bit or alternate function nodes. Contains state retention mechanism during power down.
	LCD_VST	DO			OUTPUT. LCD Start signal for the vertical driver.
	PLCD_VSYNC	DO			OUTPUT. Parallel LCD Indication signal for resetting the LCD row pointer to top of the display.
D5	P0_29	DIO	4.8	I-PD	INPUT/OUTPUT with selectable pull up/down resistor and open drain functionality. Pull-down enabled during and after reset. General-purpose I/O port bit or alternate function nodes. Contains state retention mechanism during power down.
	LCD_HCK	DO			OUTPUT. LCD Shift clock signal for the horizontal driver.
	PLCD_CLK	DO			OUTPUT. Parallel LCD Clock signal.
C3	P0_30	DIO	4.8	I-PD	INPUT/OUTPUT with selectable pull up/down resistor and open drain functionality. Pull-down enabled during and after reset. General-purpose I/O port bit or alternate function nodes. Contains state retention mechanism during power down.
	LCD_HST	DO			OUTPUT. LCD Start signal for the horizontal driver.
	PLCD_HSYNC	DO			OUTPUT. Parallel LCD Indication signal for resetting the LCD column pointer to the edge of the display.
D3	P0_31	DIO	4.8	I-PD	INPUT/OUTPUT with selectable pull up/down resistor and open drain functionality. Pull-down enabled during and after reset. General-purpose I/O port bit or alternate function nodes. Contains state retention mechanism during power down.
	LCD_XRST	DO			OUTPUT. LCD Reset signal for the horizontal and vertical driver.
E9	P1_00	DIO/ RDS	4.8/ 0.15	I-PD	INPUT/OUTPUT with selectable pull up/down resistor and open drain functionality. Pull-down enabled during and after reset. General-purpose I/O port bit or alternate function nodes. Contains state retention mechanism during power down.
	NTC Supply	AO			OUTPUT. Power supply for the battery NTC sensor.
E8	P1_01	DIO/ RDS	4.8/ 0.15	I-PD	INPUT/OUTPUT with selectable pull up/down resistor and open drain functionality. Pull-down enabled during and after reset. General-purpose I/O port bit or alternate

Ball No.	Pin name	Type	Drive (mA)	Reset state	Description
	Timer.PWM	DO			function nodes. Contains state retention mechanism during power down. OUTPUT. Timer/PWM output (PWM) in Sleep mode.
J10	P1_02	DIO/ RDS	4.8/ 0.15	I-PD	INPUT/OUTPUT with selectable pull up/down resistor and open drain functionality. Pull-down enabled during and after reset. General-purpose I/O port bit or alternate function nodes. Contains state retention mechanism during power down.
	LCD_BLUE0	DO			OUTPUT. LCD Blue image data output, bit 0.
E6	P1_03	DIO	4.8	I-PD	INPUT/OUTPUT with selectable pull up/down resistor and open drain functionality. Pull-down enabled during and after reset. General-purpose I/O port bit or alternate function nodes. Contains state retention mechanism during power down.
	LCD_BLUE1	DO			OUTPUT. LCD Blue image data output, bit 1.
H3	P1_04	DIO	4.8	I-PD	INPUT/OUTPUT with selectable pull up/down resistor and open drain functionality. Pull-down enabled during and after reset. General-purpose I/O port bit or alternate function nodes. Contains state retention mechanism during power down.
	LCD_GREEN0	DO			OUTPUT. LCD Green image data output, bit 0.
E4	P1_05	DIO	4.8	I-PD	INPUT/OUTPUT with selectable pull up/down resistor and open drain functionality. Pull-down enabled during and after reset. General-purpose I/O port bit or alternate function nodes. Contains state retention mechanism during power down.
	LCD_GREEN1	DO			OUTPUT. LCD Green image data output, bit 1.
J8	P1_06	DIO/ RDS	4.8/ 0.15	I-PD	INPUT/OUTPUT with selectable pull up/down resistor and open drain functionality. Pull-down enabled during and after reset. General-purpose I/O port bit or alternate function nodes. Contains state retention mechanism during power down.
	Timer2.PWM	DO			OUTPUT. Timer2/PWM output (PWM2) in Sleep mode.
F7	P1_07	DIO	4.8	I-PD	INPUT/OUTPUT with selectable pull up/down resistor and open drain functionality. Pull-down enabled during and after reset. General-purpose I/O port bit or alternate function nodes. Contains state retention mechanism during power down.
	LCD_RED0	DO			OUTPUT. LCD Red image data output, bit 0.
J7	P1_08	DIO	4.8	I-PD	INPUT/OUTPUT with selectable pull up/down resistor and open drain functionality. Pull-down enabled during and after reset. General-purpose I/O port bit or alternate function nodes. Contains state retention mechanism during power down.
	LCD_RED1	DO			OUTPUT. LCD Red image data output, bit 1.
G9	P1_09	DIO/ RDS	4.8/ 0.15	I-PD	INPUT/OUTPUT with selectable pull up/down resistor and open drain functionality. Pull-down enabled during and after reset. General-purpose I/O port bit or alternate function nodes. Contains state retention mechanism during power down.
	GPADC_0	AI			INPUT. Analog input for the general-purpose ADC, channel 0.
	SDADC_0	AI			INPUT. Analog input for the $\Sigma\Delta$ ADC, channel 0.
K8	P1_10	DIO	4.8	I-PD	INPUT/OUTPUT with selectable pull up/down resistor and open drain functionality. Pull-down enabled during and after reset. General-purpose I/O port bit or alternate

Multi-Core Bluetooth 5.2 SoC Family with System PMU

Ball No.	Pin name	Type	Drive (mA)	Reset state	Description
	LCD_VCOM/FRP	DO			function nodes. Contains state retention mechanism during power down. OUTPUT. Combined LCD signals: - VCOM: Common electrode driving signal (62.5 Hz). - FRP: Liquid crystal driving signal (62.5 Hz). OUTPUT. LCD COM Inversion Signal Input (1 Hz).
	LCD_EXTCOMIN	DO			
G6	P1_11	DIO	4.8	I-PD	INPUT/OUTPUT with selectable pull up/down resistor and open drain functionality. Pull-down enabled during and after reset. General-purpose I/O port bit or alternate function nodes. Contains state retention mechanism during power down. OUTPUT. LCD Liquid crystal driving signal (62.5 Hz inverted).
	LCD_XFRP	DO			
Debug Interface					
A3	M33_SWDIO	DIO	4.8	I-PU	INPUT/OUTPUT. Arm Cortex-M33 JTAG data I/O signal.
B3	M33_SWCLK	DI	4.8	I-PD	INPUT. Arm Cortex-M33 JTAG clock signal.
A4	CMAC_SWDIO	DIO	4.8	I-PU	INPUT/OUTPUT. Arm Cortex-M0+ JTAG data I/O signal.
B4	CMAC_SWCLK	DI	4.8	I-PD	INPUT. Arm Cortex-M0+ JTAG clock signal.
Clocks					
H9	XTAL32km	AO			OUTPUT. Analog output of the 32.768 kHz XTAL oscillator.
H10	XTAL32kp	AI			INPUT. Analog input of the 32.768 kHz XTAL crystal oscillator.
		DI			INPUT. Digital input for an external clock (square wave).
E10	XTAL32M_GND	AI			INPUT. Analog input ground of the 32 MHz XTAL oscillator.
F10	XTAL32Mm	AO			OUTPUT. Crystal output for the 32 MHz XTAL oscillator.
F9	XTAL32Mp	AI			INPUT. Crystal input for the 32 MHz XTAL oscillator.
QSPI Flash Interface					
A2	QSPIF_D0	DIO			INPUT/OUTPUT. QSPI Flash I/O data 0.
C2	QSPIF_D1	DIO			INPUT/OUTPUT. QSPI Flash I/O data 1.
C1	QSPIF_D2	DIO			INPUT/OUTPUT. QSPI Flash I/O data 2.
B2	QSPIF_D3	DIO			INPUT/OUTPUT. QSPI Flash I/O data 3.
A1	QSPIF_CLK	DO			OUTPUT. QSPI Flash clock.
B1	QSPIF_CS	DO			OUTPUT. QSPI Flash chip select (active LOW). This output is HIGH in the default and reset states. No pull-up resistor is required.
QSPI RAM Interface (mapped on port P0_yy)					
D2	QSPIR_D0	DIO			INPUT/OUTPUT. QSPI RAM I/O data 0. Mapped on P0_00.
F2	QSPIR_D1	DIO			INPUT/OUTPUT. QSPI RAM I/O data 1. Mapped on P0_01.
F1	QSPIR_D2	DIO			INPUT/OUTPUT. QSPI RAM I/O data 2. Mapped on P0_02.
E2	QSPIR_D3	DIO			INPUT/OUTPUT. QSPI RAM I/O data 3. Mapped on P0_03.

Multi-Core Bluetooth 5.2 SoC Family with System PMU

Ball No.	Pin name	Type	Drive (mA)	Reset state	Description
E1	QSPIR_CS	DO			OUTPUT. QSPI RAM chip select (active LOW). Mapped on P0_05.
D1	QSPIR_CLK	DO			OUTPUT. QSPI RAM clock. Mapped on P0_04.
SPI Bus Interface (mapped on port Px_yy)					
	SPI_DI	DI			INPUT. SPI data input. (Note 2)
	SPI_DO	DO			OUTPUT. SPI data output. (Note 3)
	SPI_CLK	DIO			INPUT/OUTPUT. SPI clock.
	SPI_EN	DI			INPUT. SPI clock enable (chip select).
	SPI2_DI	DI			INPUT. SPI 2 data input. (Note 2)
	SPI2_DO	DO			OUTPUT. SPI 2 data output. (Note 3)
	SPI2_CLK	DIO			INPUT/OUTPUT. SPI 2 clock.
	SPI2_EN	DI			INPUT. SPI 2 clock enable (chip select).
I2C Bus Interface (mapped on port Px_yy)					
	I2C_SCL	DIO/ DIOD			INPUT/OUTPUT. I2C bus clock with open drain port. Supports bit stretching by a slave in open drain mode.
	I2C_SDA	DIO/ DIOD			INPUT/OUTPUT. I2C bus data with open drain port.
	I2C2_SCL	DIO/ DIOD			INPUT/OUTPUT. I2C bus 2 clock with open drain port. Supports bit stretching by a slave in open drain mode.
	I2C2_SDA	DIO/ DIOD			INPUT/OUTPUT. I2C bus 2 data with open drain port.
UART Interface (mapped on port Px_yy)					
	UART_RX	DI			INPUT. UART receive data.
	UART_TX	DO			OUTPUT. UART transmit data.
	UART2_RX	DI			INPUT. UART 2 receive data.
	UART2_TX	DO			OUTPUT. UART 2 transmit data.
	UART2_CTS	DI			INPUT. UART 2 clear to send.
	UART2_RTS	DO			OUTPUT. UART 2 request to send.
	UART3_RX	DI			INPUT. UART 3 receive data.
	UART3_TX	DO			OUTPUT. UART 3 transmit data.
	UART3_CTS	DI			INPUT. UART 3 clear to send.
	UART3_RTS	DO			OUTPUT. UART 3 request to send.
ISO7816 Bus Interface (mapped on port Px_yy)					
	ISO7816_CLK	DO			OUTPUT. Smart card (ISO7816) clock signal
	ISO7816_DATA	DIO			INPUT/OUTPUT. Smart card (ISO7816) I/O data signal.
	ISO7816_RST	DO			OUTPUT. Smart card (ISO7816) reset signal.
	ISO7816_CI	DI			INPUT. Smart card (ISO7816) inserted signal.
PCM Interface (mapped on port Px_yy)					
	PCM_DI	DI			INPUT. PCM input data.
	PCM_DO	DO			OUTPUT. PCM output data.
	PCM_FSC	DIO			INPUT/OUTPUT. PCM Frame synchronization.
	PCM_CLK	DIO			INPUT/OUTPUT. PCM Clock

Multi-Core Bluetooth 5.2 SoC Family with System PMU

Ball No.	Pin name	Type	Drive (mA)	Reset state	Description
PDM Interface (mapped on port Px_yy)					
	PDM_DATA	DIO			INPUT/OUTPUT. PDM data.
	PDM_CLK	DO			OUTPUT. PDM clock output.
LCD Controller Interface					
	LCD_SPI_DC (Note 1)	DO			OUTPUT. LCD data/command select.
	LCD_SPI_DO (Note 1)	DO			OUTPUT. LCD SPI data output.
	LCD_SPI_CLK (Note 1)	DO			OUTPUT. LCD SPI clock.
	LCD_SPI_EN (Note 1)	DO			OUTPUT. LCD SPI clock enable (chip select).
F7	LCD_RED0 (Note 1)	DO			LCD Red image data output, bit 0.
J7	LCD_RED1 (Note 1)	DO			LCD Red image data output, bit 1.
H3	LCD_GREEN0 (Note 1)	DO			LCD Green image data output, bit 0.
E4	LCD_GREEN1 (Note 1)	DO			LCD Green image data output, bit 1.
J10	LCD_BLUE0 (Note 1)	DO			LCD Blue image data output, bit 0.
E6	LCD_BLUE1 (Note 1)	DO			LCD Blue image data output, bit 1.
C10	PLCD_ENAB (Note 1)	DO			OUTPUT. Parallel LCD Indication signal for valid data on the LCD data bus.
D5	PLCD_CLK (Note 1)	DO			OUTPUT. Parallel LCD Clock signal.
C3	PLCD_HSYNC (Note 1)	DO			OUTPUT. Parallel LCD Indication signal for resetting the LCD column pointer to the edge of the display.
H5	PLCD_VSYNC (Note 1)	DO			OUTPUT. Parallel LCD Indication signal for resetting the LCD row pointer to top of the display.
C10	LCD_ENB (Note 1)	DO			OUTPUT. LCD Write enable signal for the pixel memory.
C3	LCD_HST (Note 1)	DO			OUTPUT. LCD Start signal for the horizontal driver.
D5	LCD_HCK (Note 1)	DO			OUTPUT. LCD Shift clock signal for the horizontal driver.
H5	LCD_VST (Note 1)	DO			OUTPUT. LCD Start signal for the vertical driver.
D3	LCD_XRST (Note 1)	DO			OUTPUT. LCD Reset signal for the horizontal and vertical driver.
H7	LCD_VCK (Note 1)	DO			OUTPUT. LCD Shift clock for the vertical driver.
J9	LCD_TE (Note 1)	DI			INPUT. LCD Tearing effect signal. Used to synchronize the CPU to the frame memory writing.

Multi-Core Bluetooth 5.2 SoC Family with System PMU

Ball No.	Pin name	Type	Drive (mA)	Reset state	Description
K8	LCD_VCOM/LC D_FRP (Note 1)	DO			OUTPUT. Combined LCD signals into a single pin: - VCOM: Common electrode driving signal (62.5 Hz). - FRP: Liquid crystal driving signal (62.5 Hz)
K8	LCD_EXTCOMIN (Note 1)	DO			OUTPUT. LCD COM Inversion Signal Input (1 Hz).
G6	LCD_XFRP (Note 1)	DO			OUTPUT. LCD Liquid crystal driving signal (62.5 Hz inverted).
Analog Interface					
G9	GPADC_0	AI			INPUT. Analog input for the general-purpose ADC, channel 0.
H8	GPADC_1	AI			INPUT. Analog input for the general-purpose ADC, channel 1.
D6	GPADC_2	AI			INPUT. Analog input for the general-purpose ADC, channel 2.
B5	GPADC_3	AI			INPUT. Analog input for the general-purpose ADC, channel 3.
G9	SDADC_0	AI			INPUT. Analog input for the $\Sigma\Delta$ ADC, channel 0.
H8	SDADC_1	AI			INPUT. Analog input for the $\Sigma\Delta$ ADC, channel 1.
D6	SDADC_2	AI			INPUT. Analog input for the $\Sigma\Delta$ ADC, channel 2.
B5	SDADC_3	AI			INPUT. Analog input for the $\Sigma\Delta$ ADC, channel 3.
B10	SDADC_GND	AI			INPUT. Analog input for the $\Sigma\Delta$ ADC reference ground.
C9	SDADC_REF	AI			INPUT. Analog input for the $\Sigma\Delta$ ADC reference voltage.
USB FS Interface					
K6	USBp	AIO			INPUT/OUTPUT. Analog USB Full Speed D+ signal.
K7	USBm	AIO			INPUT/OUTPUT. Analog USB Full Speed D- signal.
Radio Interface					
A8	RFIOP	AIO			RF input/output. Impedance 50 Ω .
A7	RFIOM	AIO			RF Ground
Miscellaneous					
B9	NTC Input	AI			INPUT. Analog input for battery NTC (feedback).
E9	NTC Supply	AO			OUTPUT. Power supply for battery NTC sensor.
B8	RSTn	AI			INPUT. Reset signal (active LOW).
Power Supply					
J2	V12	AO			OUTPUT. 1.2 V power rail. 10 μ F decoupling capacitor required.
H1	V14	AIO			OUTPUT. 1.4 V power rail. 10 μ F decoupling capacitor required.
A5	VSUP_RF	AI			INPUT. Radio supply voltage. Connect to V14 externally. 10 μ F decoupling capacitor required.
G1	V18F	AIO			OUTPUT. 1.8 V power rail. Maximum current 50 mA. 0.1 μ F decoupling capacitor required. Connect to V18P externally.
G2	V18P	AIO			OUTPUT. 1.8 V power rail. Maximum current 50 mA. 22 μ F decoupling capacitor required.

Multi-Core Bluetooth 5.2 SoC Family with System PMU

Ball No.	Pin name	Type	Drive (mA)	Reset state	Description
H2	V18	AIO			OUTPUT. 1.8 V power rail. Maximum current 50 mA. 22 μ F decoupling capacitor required.
J6	V30	AIO			OUTPUT. 3.0 V power rail. Maximum current 150 mA. 4.7 μ F decoupling capacitor required.
K1	LX	AIO			INPUT/OUTPUT. Connection for the external DC-DC converter inductor.
J1	LY	AIO			INPUT/OUTPUT. Connection for the external DC-DC converter inductor.
K5	VBAT1	AIO			INPUT. Battery connection 1 for LDO supply.
K2	VBAT2	AIO			INPUT. Battery connection 2 for DC-DC converter supply.
J5	VBUS	AI AI			INPUT. USB bus voltage. INPUT. Battery charge voltage.
F5	AVS1	-			Analog Ground.
G5	AVS2	-			Analog Ground.
K3	BUCK GND	-			DCDC Converter Ground.
G3	VSSD1	-			Digital Ground.
G4	VSSD2	-			Digital Ground.
F4	VSSD3	-			Digital Ground.
F3	VSSIOQ	-			QSPI Ground.
B7	ESDN	-			RF Ground.
A9	RFIOM2	-			RF Ground.
D10	GND_RF1	-			RF Ground.
D9	GND_RF2	-			RF Ground.
A10	PSUB_RF	-			RF Ground.
A6	PSUB	-			RF Ground.
J3	GND	-			Connect to Ground.
J4	NC				Leave unconnected.
K4	NC				Leave unconnected.
K9	GND				Connect to Ground.
K10	GND				Connect to Ground.

4.2 VFBGA100 Pinout

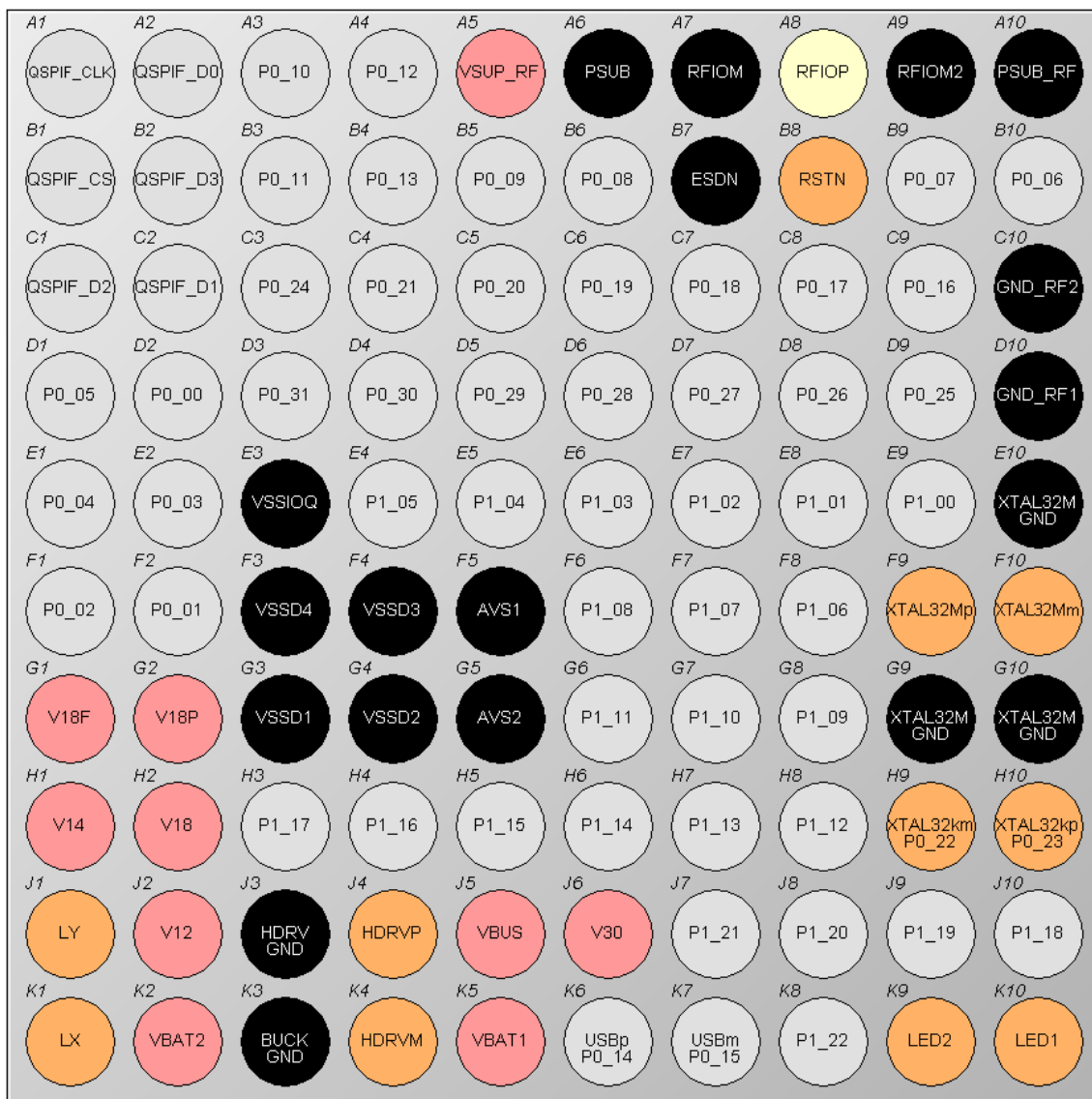

DA14697/9
TOP VIEW

Digital
 Analog
 Radio
 Power
 GND

Figure 6. VFBGA100 ball assignment

Table 3: DA14697/9 pin description

Ball No.	Pin name	Type	Drive (mA)	Reset state	Description
General Purpose I/Os (fixed pin assignment; additional functions are programmable through Px_xx_MODE_REG)					
D2	P0_00 QSPIR_D0 PG3_4	DIO DIO DO	4/8/12/16	I-PD	INPUT/OUTPUT with selectable pull up/down resistor and open drain functionality. Pull-down enabled during and after reset. General-purpose I/O port bit or alternate function nodes. Contains state retention mechanism during power down. (Note 5) INPUT/OUTPUT. QSPI RAM data I/O 0. OUTPUT. Pattern Generator 3, Output 4
F2	P0_01 QSPIR_D1 PG4_2	DIO DIO DO	4/8/12/16	I-PD	INPUT/OUTPUT with selectable pull up/down resistor and open drain functionality. Pull-down enabled during and after reset. General-purpose I/O port bit or alternate function nodes. Contains state retention mechanism during power down. (Note 5) INPUT/OUTPUT. QSPI RAM data I/O 1. OUTPUT. Pattern Generator 4, Output 2
F1	P0_02 QSPIR_D2 PG4_1	DIO DIO DO	4/8/12/16	I-PD	INPUT/OUTPUT with selectable pull up/down resistor and open drain functionality. Pull-down enabled during and after reset. General-purpose I/O port bit or alternate function nodes. Contains state retention mechanism during power down. (Note 5) INPUT/OUTPUT. QSPI RAM data I/O 2. OUTPUT. Pattern Generator 4, Output 1
E2	P0_03 QSPIR_D3 PG3_2	DIO DIO DO	4/8/12/16	I-PD	INPUT/OUTPUT with selectable pull up/down resistor and open drain functionality. Pull-down enabled during and after reset. General-purpose I/O port bit or alternate function nodes. Contains state retention mechanism during power down. (Note 5) INPUT/OUTPUT. QSPI RAM data I/O 3. OUTPUT. Pattern Generator 3, Output 2
E1	P0_04 QSPIR_CS PG3_1	DIO DO DO	4/8/12/16	I-PU	INPUT/OUTPUT with selectable pull up/down resistor and open drain functionality. Pull-down enabled during and after reset. General-purpose I/O port bit or alternate function nodes. Contains state retention mechanism during power down. (Note 5) OUTPUT. QSPI RAM chip select (active LOW). OUTPUT. Pattern Generator 3, Output 1
D1	P0_05 QSPIR_CLK PG3_3	DIO DO DO	4/8/12/16	I-PD	INPUT/OUTPUT with selectable pull up/down resistor and open drain functionality. Pull-down enabled during and after reset. General-purpose I/O port bit or alternate function nodes. Contains state retention mechanism during power down. (Note 5) OUTPUT. QSPI RAM clock. OUTPUT. Pattern Generator 3, Output 3
B10	P0_06 SDADC_GND	DIO/ RDS AI	4.8/ 0.15 (Note 4)	I-PD	INPUT/OUTPUT with selectable pull up/down resistor and open drain functionality. Pull-down enabled during and after reset. General-purpose I/O port bit or alternate function nodes. Contains state retention mechanism during power down. INPUT. Analog input for the $\Sigma\Delta$ ADC reference ground.
B9	P0_07	DIO/ RDS	4.8/ 0.15	I-PD	INPUT/OUTPUT with selectable pull up/down resistor and open drain functionality. Pull-down enabled during and after reset. General-purpose I/O port bit or alternate function nodes. Contains state retention mechanism

Ball No.	Pin name	Type	Drive (mA)	Reset state	Description
	NTC Input	AI			during power down. INPUT. Analog input for battery NTC (feedback).
B6	P0_08 GPADC_2 SDADC_2 PG4_3 UART Boot RX	DIO AI AI DO DI	4.8	I-PD	INPUT/OUTPUT with selectable pull up/down resistor and open drain functionality. Pull-down enabled during and after reset. General-purpose I/O port bit or alternate function nodes. Contains state retention mechanism during power down. INPUT. Analog input for the general-purpose ADC, channel 2. INPUT. Analog input for the $\Sigma\Delta$ ADC, channel 2. OUTPUT. Pattern Generator 3, Output 3. INPUT. UART Receive data input during boot.
B5	P0_09 GPADC_3 SDADC_3 PG4_4 UART Boot TX	DIO AI AI DO DO	4.8	I-PD	INPUT/OUTPUT with selectable pull up/down resistor and open drain functionality. Pull-down enabled during and after reset. General-purpose I/O port bit or alternate function nodes. Contains state retention mechanism during power down. INPUT. Analog input for the general-purpose ADC, channel 3 INPUT. Analog input for the $\Sigma\Delta$ ADC, channel 3. OUTPUT. Pattern Generator 4, Output 4. OUTPUT. UART Transmit data output during boot.
A3	P0_10 M33_SWDIO	DIO DIO	4.8	I-PU	INPUT/OUTPUT with selectable pull up/down resistor and open drain functionality. Pull-down enabled during and after reset. General-purpose I/O port bit or alternate function nodes. Contains state retention mechanism during power down. INPUT/OUTPUT. Arm Cortex-M33 JTAG data I/O signal.
B3	P0_11 M33_SWCLK	DIO DI	4.8	I-PD	INPUT/OUTPUT with selectable pull up/down resistor and open drain functionality. Pull-down enabled during and after reset. General-purpose I/O port bit or alternate function nodes. Contains state retention mechanism during power down. INPUT. Arm Cortex-M33 JTAG clock signal.
A4	P0_12 CMAC_SWDIO XTAL32M	DIO DIO DO	4.8	I-PU	INPUT/OUTPUT with selectable pull up/down resistor and open drain functionality. Pull-down enabled during and after reset. General-purpose I/O port bit or alternate function nodes. Contains state retention mechanism during power down. INPUT/OUTPUT. Arm Cortex-M0+ JTAG data I/O signal. OUTPUT. LCD Start signal for the horizontal driver.
B4	P0_13 CMAC_SWCLK RC32M	DIO DI DO	4.8	I-PD	INPUT/OUTPUT with selectable pull up/down resistor and open drain functionality. Pull-down enabled during and after reset. General-purpose I/O port bit or alternate function nodes. Contains state retention mechanism during power down. INPUT. Arm Cortex-M0+ JTAG clock signal. OUTPUT. RC32M clock signal output (square wave).
K6	P0_14 USBp XTAL32k	DIO AIO DO	4.8	I-PD	INPUT/OUTPUT with selectable pull up/down resistor and open drain functionality. Pull-down enabled during and after reset. General-purpose I/O port bit or alternate function nodes. Does not contain state retention mechanism during power down. INPUT/OUTPUT. Analog USB Full Speed D+ signal. OUTPUT. XTAL32k clock signal output (square wave).

Ball No.	Pin name	Type	Drive (mA)	Reset state	Description
K7	P0_15	DIO	4.8	I-PD	INPUT/OUTPUT with selectable pull up/down resistor and open drain functionality. Pull-down enabled during and after reset. General-purpose I/O port bit or alternate function nodes. Does not contain state retention mechanism during power down.
	USBm DIVN	AIO DO			INPUT/OUTPUT. Analog USB Full Speed D- signal. OUTPUT. DIVN clock signal output (square wave).
C9	P0_16	DIO/ RDS	4.8/ 0.15	I-PD	INPUT/OUTPUT with selectable pull up/down resistor and open drain functionality. Pull-down enabled during and after reset. General-purpose I/O port bit or alternate function nodes. Contains state retention mechanism during power down.
	SDADC_REF RCX	AI DO			INPUT. Analog input for the $\Sigma\Delta$ ADC reference voltage. OUTPUT. RCX clock signal output (square wave).
C8	P0_17	DIO/ RDS	4.8/ 0.15	I-PD	INPUT/OUTPUT with selectable pull up/down resistor and open drain functionality. Pull-down enabled during and after reset. General-purpose I/O port bit or alternate function nodes. Contains state retention mechanism during power down.
	PG2_1 RC32k	DO DO			OUTPUT. Pattern Generator 2, Output 1. OUTPUT. RC32k clock signal output (square wave).
C7	P0_18	DIO/ RDS	4.8/ 0.15	I-PD	INPUT/OUTPUT with selectable pull up/down resistor and open drain functionality. Pull-down enabled during and after reset. General-purpose I/O port bit or alternate function nodes. Contains state retention mechanism during power down.
	PG2_2	DO			OUTPUT. Pattern Generator 2, Output 2
C6	P0_19	DIO	4.8	I-PD	INPUT/OUTPUT with selectable pull up/down resistor and open drain functionality. Pull-down enabled during and after reset. General-purpose I/O port bit or alternate function nodes. Contains state retention mechanism during power down.
	PG2_3	DO			OUTPUT. Pattern Generator 2, Output 3.
C5	P0_20	DIO	4.8	I-PD	INPUT/OUTPUT with selectable pull up/down resistor and open drain functionality. Pull-down enabled during and after reset. General-purpose I/O port bit or alternate function nodes. Contains state retention mechanism during power down.
	PG2_4	DO			OUTPUT. Pattern Generator 2, Output 4.
C4	P0_21	DIO	4.8	I-PD	INPUT/OUTPUT with selectable pull up/down resistor and open drain functionality. Pull-down enabled during and after reset. General-purpose I/O port bit or alternate function nodes. Contains state retention mechanism during power down.
	PG1_3	DO			OUTPUT. Pattern Generator 1, Output 3.
H9	P0_22	DIO	4.8	I-PD	INPUT/OUTPUT with selectable pull up/down resistor and open drain functionality. Pull-down enabled during and after reset. General-purpose I/O port bit or alternate function nodes. Contains state retention mechanism during power down.
	XTAL32km	AO			OUTPUT. Analog output of the XTAL32K crystal oscillator.
H10	P0_23	DIO	4.8	I-PD	INPUT/OUTPUT with selectable pull up/down resistor and open drain functionality. Pull-down enabled during and after reset. General-purpose I/O port bit or alternate function nodes. Contains state retention mechanism

Ball No.	Pin name	Type	Drive (mA)	Reset state	Description
	XTAL32kp	AI DI			during power down. INPUT. Analog input of the XTAL32K crystal oscillator. INPUT. Digital input for an external clock (square wave).
C3	P0_24 PG1_4 LCD_TE	DIO DO DI	4.8	I-PD	INPUT/OUTPUT with selectable pull up/down resistor and open drain functionality. Pull-down enabled during and after reset. General-purpose I/O port bit or alternate function nodes. Contains state retention mechanism during power down. OUTPUT. Pattern Generator 1, Output 4. INPUT. LCD Tearing effect signal. Used to synchronize the CPU to the frame memory writing.
D9	P0_25 GPADC_1 SDADC_1	DIO/ RDS AI AI	4.8/ 0.15	I-PD	INPUT/OUTPUT with selectable pull up/down resistor and open drain functionality. Pull-down enabled during and after reset. General-purpose I/O port bit or alternate function nodes. Contains state retention mechanism during power down. INPUT. Analog input for the general-purpose ADC, channel 1. INPUT. Analog input for the $\Sigma\Delta$ ADC, channel 1.
D8	P0_26 PG0_1 LCD_VCK	DIO/ RDS DO DO	4.8/ 0.15	I-PD	INPUT/OUTPUT with selectable pull up/down resistor and open drain functionality. Pull-down enabled during and after reset. General-purpose I/O port bit or alternate function nodes. Contains state retention mechanism during power down. OUTPUT. Pattern Generator 0, Output 1. OUTPUT. LCD Shift clock for the vertical driver.
D7	P0_27 PG0_2 LCD_ENB PLCD_ENAB	DIO/ RDS DO DO DO	4.8/ 0.15	I-PD	INPUT/OUTPUT with selectable pull up/down resistor and open drain functionality. Pull-down enabled during and after reset. General-purpose I/O port bit or alternate function nodes. Contains state retention mechanism during power down. OUTPUT. Pattern Generator 0, Output 2. OUTPUT. LCD Write enable signal for the pixel memory. OUTPUT. Parallel LCD Indication signal for valid data on the LCD data bus.
D6	P0_28 PG0_3 LCD_VST PLCD_VSYNC	DIO DO DO DO	4.8	I-PD	INPUT/OUTPUT with selectable pull up/down resistor and open drain functionality. Pull-down enabled during and after reset. General-purpose I/O port bit or alternate function nodes. Contains state retention mechanism during power down. OUTPUT. Pattern Generator 0, Output 3. OUTPUT. LCD Start signal for the vertical driver. OUTPUT. Parallel LCD Indication signal for resetting the LCD row pointer to top of the display.
D5	P0_29 PG0_4 LCD_HCK PLCD_CLK	DIO DO DO DO	4.8	I-PD	INPUT/OUTPUT with selectable pull up/down resistor and open drain functionality. Pull-down enabled during and after reset. General-purpose I/O port bit or alternate function nodes. Contains state retention mechanism during power down. OUTPUT. Pattern Generator 0, Output 4. OUTPUT. LCD Shift clock signal for the horizontal driver. OUTPUT. Parallel LCD Clock signal.
D4	P0_30	DIO	4.8	I-PD	INPUT/OUTPUT with selectable pull up/down resistor and open drain functionality. Pull-down enabled during and after reset. General-purpose I/O port bit or alternate function nodes. Contains state retention mechanism during power down.

Multi-Core Bluetooth 5.2 SoC Family with System PMU

Ball No.	Pin name	Type	Drive (mA)	Reset state	Description
	PG1_1 LCD_HST PLCD_HSYNC	DO DO DO			OUTPUT. Pattern Generator 1, Output 1. OUTPUT. LCD Start signal for the horizontal driver. OUTPUT. Parallel LCD Indication signal for resetting the LCD column pointer to the edge of the display.
D3	P0_31 PG1_2 LCD_XRST	DIO DO DO	4.8	I-PD	INPUT/OUTPUT with selectable pull up/down resistor and open drain functionality. Pull-down enabled during and after reset. General-purpose I/O port bit or alternate function nodes. Contains state retention mechanism during power down. OUTPUT. Pattern Generator 1, Output 2. OUTPUT. LCD Reset signal for the horizontal and vertical driver.
E9	P1_00 NTC Supply	DIO/ RDS AO	4.8/ 0.15	I-PD	INPUT/OUTPUT with selectable pull up/down resistor and open drain functionality. Pull-down enabled during and after reset. General-purpose I/O port bit or alternate function nodes. Contains state retention mechanism during power down. OUTPUT. Power supply for the battery NTC sensor.
E8	P1_01 Timer.PWM	DIO/ RDS DO	4.8/ 0.15	I-PD	INPUT/OUTPUT with selectable pull up/down resistor and open drain functionality. Pull-down enabled during and after reset. General-purpose I/O port bit or alternate function nodes. Contains state retention mechanism during power down. OUTPUT. Timer/PWM output (PWM) in Sleep mode.
E7	P1_02 LCD_BLUE0	DIO/ RDS DO	4.8/ 0.15	I-PD	INPUT/OUTPUT with selectable pull up/down resistor and open drain functionality. Pull-down enabled during and after reset. General-purpose I/O port bit or alternate function nodes. Contains state retention mechanism during power down. OUTPUT. LCD Blue image data output, bit 0.
E6	P1_03 LCD_BLUE1	DIO DO	4.8	I-PD	INPUT/OUTPUT with selectable pull up/down resistor and open drain functionality. Pull-down enabled during and after reset. General-purpose I/O port bit or alternate function nodes. Contains state retention mechanism during power down. OUTPUT. LCD Blue image data output, bit 1.
E5	P1_04 LCD_GREEN0	DIO DO	4.8	I-PD	INPUT/OUTPUT with selectable pull up/down resistor and open drain functionality. Pull-down enabled during and after reset. General-purpose I/O port bit or alternate function nodes. Contains state retention mechanism during power down. OUTPUT. LCD Green image data output, bit 0.
E4	P1_05 LCD_GREEN1	DIO DO	4.8	I-PD	INPUT/OUTPUT with selectable pull up/down resistor and open drain functionality. Pull-down enabled during and after reset. General-purpose I/O port bit or alternate function nodes. Contains state retention mechanism during power down. OUTPUT. LCD Green image data output, bit 1.
F8	P1_06 Timer2.PWM	DIO/ RDS DO	4.8/ 0.15	I-PD	INPUT/OUTPUT with selectable pull up/down resistor and open drain functionality. Pull-down enabled during and after reset. General-purpose I/O port bit or alternate function nodes. Contains state retention mechanism during power down. OUTPUT. Timer2/PWM output (PWM2) in Sleep mode.
F7	P1_07	DIO	4.8	I-PD	INPUT/OUTPUT with selectable pull up/down resistor and open drain functionality. Pull-down enabled during and

Ball No.	Pin name	Type	Drive (mA)	Reset state	Description
	LCD_RED0	DO			after reset. General-purpose I/O port bit or alternate function nodes. Contains state retention mechanism during power down. OUTPUT. LCD Red image data output, bit 0.
F6	P1_08	DIO	4.8	I-PD	INPUT/OUTPUT with selectable pull up/down resistor and open drain functionality. Pull-down enabled during and after reset. General-purpose I/O port bit or alternate function nodes. Contains state retention mechanism during power down.
	LCD_RED1	DO			OUTPUT. LCD Red image data output, bit 1.
G8	P1_09	DIO/ RDS	4.8/ 0.15	I-PD	INPUT/OUTPUT with selectable pull up/down resistor and open drain functionality. Pull-down enabled during and after reset. General-purpose I/O port bit or alternate function nodes. Contains state retention mechanism during power down.
	GPADC_0	AI			INPUT. Analog input for the general-purpose ADC, channel 0.
	SDADC_0	AI			INPUT. Analog input for the $\Sigma\Delta$ ADC, channel 0.
G7	P1_10	DIO	4.8	I-PD	INPUT/OUTPUT with selectable pull up/down resistor and open drain functionality. Pull-down enabled during and after reset. General-purpose I/O port bit or alternate function nodes. Contains state retention mechanism during power down.
	LCD_VCOM/FRP	DO			OUTPUT. Combined LCD signals: - VCOM: Common electrode driving signal (62.5 Hz). - FRP: Liquid crystal driving signal (62.5 Hz).
	LCD_EXTCOMIN	DO			OUTPUT. LCD COM Inversion Signal Input (1 Hz).
G6	P1_11	DIO	4.8	I-PD	INPUT/OUTPUT with selectable pull up/down resistor and open drain functionality. Pull-down enabled during and after reset. General-purpose I/O port bit or alternate function nodes. Contains state retention mechanism during power down.
	LCD_XFRP	DO			OUTPUT. LCD Liquid crystal driving signal (62.5 Hz inverted).
H8	P1_12	DIO	4.8	I-PD	INPUT/OUTPUT with selectable pull up/down resistor and open drain functionality. Pull-down enabled during and after reset. General-purpose I/O port bit or alternate function nodes. Contains state retention mechanism during power down.
	GPADC_5	AI			INPUT. Analog input for the general-purpose ADC, channel 5.
H7	P1_13	DIO	4.8	I-PD	INPUT/OUTPUT with selectable pull up/down resistor and open drain functionality. Pull-down enabled during and after reset. General-purpose I/O port bit or alternate function nodes. Contains state retention mechanism during power down.
	GPADC_4	AI			INPUT. Analog input for the general-purpose ADC, channel 4.
	LCD_VCK	DO			OUTPUT. LCD Shift clock for the vertical driver.
H6	P1_14	DIO	4.8	I-PD	INPUT/OUTPUT with selectable pull up/down resistor and open drain functionality. Pull-down enabled during and after reset. General-purpose I/O port bit or alternate function nodes. Contains state retention mechanism during power down.
	SDADC_4	AI			INPUT. Analog input for the $\Sigma\Delta$ ADC, channel 4.
	LCD_ENB	DO			OUTPUT. LCD Write enable signal for the pixel memory.
	PLCD_ENAB	DO			

Ball No.	Pin name	Type	Drive (mA)	Reset state	Description
					OUTPUT. Parallel LCD Indication signal for valid data on the LCD data bus.
H5	P1_15 LCD_VST PLCD_VSYNC	DIO DO DO	4.8	I-PD	INPUT/OUTPUT with selectable pull up/down resistor and open drain functionality. Pull-down enabled during and after reset. General-purpose I/O port bit or alternate function nodes. Contains state retention mechanism during power down. OUTPUT. LCD Start signal for the vertical driver. OUTPUT. Parallel LCD Indication signal for resetting the LCD row pointer to top of the display.
H4	P1_16 LCD_HCK PLCD_CLK	DIO DO DO	4.8	I-PD	INPUT/OUTPUT with selectable pull up/down resistor and open drain functionality. Pull-down enabled during and after reset. General-purpose I/O port bit or alternate function nodes. Contains state retention mechanism during power down. OUTPUT. LCD Shift clock signal for the horizontal driver. OUTPUT. Parallel LCD Clock signal.
H3	P1_17 LCD_HST PLCD_HSYNC	DIO DO DO	4.8	I-PD	INPUT/OUTPUT with selectable pull up/down resistor and open drain functionality. Pull-down enabled during and after reset. General-purpose I/O port bit or alternate function nodes. Contains state retention mechanism during power down. OUTPUT. XTAL32M clock signal output (square wave). OUTPUT. Parallel LCD Indication signal for resetting the LCD column pointer to the edge of the display.
J10	P1_18 GPADC_6	DIO AI	4.8	I-PD	INPUT/OUTPUT with selectable pull up/down resistor and open drain functionality. Pull-down enabled during and after reset. General-purpose I/O port bit or alternate function nodes. Contains state retention mechanism during power down. INPUT. Analog input for the general-purpose ADC, channel 6.
J9	P1_19 GPADC_7	DIO AI	4.8	I-PD	INPUT/OUTPUT with selectable pull up/down resistor and open drain functionality. Pull-down enabled during and after reset. General-purpose I/O port bit or alternate function nodes. Contains state retention mechanism during power down. INPUT. Analog input for the general-purpose ADC, channel 7.
J8	P1_20 SDADC_5	DIO AI	4.8	I-PD	INPUT/OUTPUT with selectable pull up/down resistor and open drain functionality. Pull-down enabled during and after reset. General-purpose I/O port bit or alternate function nodes. Contains state retention mechanism during power down. INPUT. Analog input for the $\Sigma\Delta$ ADC, channel 5.
J7	P1_21 SDADC_6 LCD_XRST	DIO AI DO	4.8	I-PD	INPUT/OUTPUT with selectable pull up/down resistor and open drain functionality. Pull-down enabled during and after reset. General-purpose I/O port bit or alternate function nodes. Contains state retention mechanism during power down. INPUT. Analog input for the $\Sigma\Delta$ ADC, channel 6. OUTPUT. LCD Reset signal for the horizontal and vertical driver.
K8	P1_22	DIO	4.8	I-PD	INPUT/OUTPUT with selectable pull up/down resistor and open drain functionality. Pull-down enabled during and after reset. General-purpose I/O port bit or alternate

Multi-Core Bluetooth 5.2 SoC Family with System PMU

Ball No.	Pin name	Type	Drive (mA)	Reset state	Description
	SDADC_7 LCD_TE	AI DI			function nodes. Contains state retention mechanism during power down. INPUT. Analog input for the $\Sigma\Delta$ ADC, channel 7. INPUT. LCD Tearing effect signal. Used to synchronize the CPU to the frame memory writing.
Debug Interface					
A3	M33_SWDIO	DIO	4.8	I-PU	INPUT/OUTPUT. Arm Cortex-M33 JTAG data I/O signal.
B3	M33_SWCLK	DI	4.8	I-PD	INPUT. Arm Cortex-M33 JTAG clock signal.
A4	CMAC_SWDIO	DIO	4.8	I-PU	INPUT/OUTPUT. Arm Cortex-M0+ JTAG data I/O signal.
B4	CMAC_SWCLK	DI	4.8	I-PD	INPUT. Arm Cortex-M0+ JTAG clock signal.
Clocks					
H9	XTAL32km	AO			OUTPUT. Analog output of the 32.768 kHz XTAL oscillator.
H10	XTAL32kp	AI DI			INPUT. Analog input of the 32.768 kHz XTAL crystal oscillator. INPUT. Digital input for an external clock (square wave).
E10, G9, G10	XTAL32M_GND	AI			INPUT. Analog input ground of the 32 MHz XTAL oscillator.
F10	XTAL32Mm	AO			OUTPUT. Crystal output for the 32 MHz XTAL oscillator.
F9	XTAL32Mp	AI			INPUT. Crystal input for the 32 MHz XTAL oscillator.
QSPI Flash Interface					
A2	QSPIF_D0	DIO			INPUT/OUTPUT. QSPI Flash I/O data 0.
C2	QSPIF_D1	DIO			INPUT/OUTPUT. QSPI Flash I/O data 1.
C1	QSPIF_D2	DIO			INPUT/OUTPUT. QSPI Flash I/O data 2.
B2	QSPIF_D3	DIO			INPUT/OUTPUT. QSPI Flash I/O data 3.
A1	QSPIF_CLK	DO			OUTPUT. QSPI Flash clock.
B1	QSPIF_CS	DO			OUTPUT. QSPI Flash chip select (active LOW). This output is HIGH in the default and reset states. No pull-up resistor is required.
QSPI RAM Interface (mapped on port P0_yy)					
D2	QSPIR_D0	DIO			INPUT/OUTPUT. QSPI RAM I/O data 0. Mapped on P0_00.
F2	QSPIR_D1	DIO			INPUT/OUTPUT. QSPI RAM I/O data 1. Mapped on P0_01.
F1	QSPIR_D2	DIO			INPUT/OUTPUT. QSPI RAM I/O data 2. Mapped on P0_02.
E2	QSPIR_D3	DIO			INPUT/OUTPUT. QSPI RAM I/O data 3. Mapped on P0_03.
E1	QSPIR_CS	DO			OUTPUT. QSPI RAM chip select (active LOW). Mapped on P0_05.
D1	QSPIR_CLK	DO			OUTPUT. QSPI RAM clock. Mapped on P0_04.
SPI Bus Interface (mapped on port Px_yy)					
	SPI_DI	DI			INPUT. SPI data input. (Note 2)
	SPI_DO	DO			OUTPUT. SPI data output. (Note 3)
	SPI_CLK	DIO			INPUT/OUTPUT. SPI clock.

Ball No.	Pin name	Type	Drive (mA)	Reset state	Description
	SPI_EN	DI			INPUT. SPI clock enable (chip select).
	SPI2_DI	DI			INPUT. SPI 2 data input. (Note 2)
	SPI2_DO	DO			OUTPUT. SPI 2 data output. (Note 3)
	SPI2_CLK	DIO			INPUT/OUTPUT. SPI 2 clock.
	SPI2_EN	DI			INPUT. SPI 2 clock enable (chip select).
I2C Bus Interface (mapped on port Px_yy)					
	I2C_SCL	DIO/ DIOD			INPUT/OUTPUT. I2C bus clock with open drain port. Supports bit stretching by a slave in open drain mode.
	I2C_SDA	DIO/ DIOD			INPUT/OUTPUT. I2C bus data with open drain port.
	I2C2_SCL	DIO/ DIOD			INPUT/OUTPUT. I2C bus 2 clock with open drain port. Supports bit stretching by a slave in open drain mode.
	I2C2_SDA	DIO/ DIOD			INPUT/OUTPUT. I2C bus 2 data with open drain port.
UART Interface (mapped on port Px_yy)					
	UART_RX	DI			INPUT. UART receive data.
	UART_TX	DO			OUTPUT. UART transmit data.
	UART2_RX	DI			INPUT. UART 2 receive data.
	UART2_TX	DO			OUTPUT. UART 2 transmit data.
	UART2_CTS	DI			INPUT. UART 2 clear to send.
	UART2_RTS	DO			OUTPUT. UART 2 request to send.
	UART3_RX	DI			INPUT. UART 3 receive data.
	UART3_TX	DO			OUTPUT. UART 3 transmit data.
	UART3_CTS	DI			INPUT. UART 3 clear to send.
	UART3_RTS	DO			OUTPUT. UART 3 request to send.
ISO7816 Bus Interface (mapped on port Px_yy)					
	ISO7816_CLK	DO			OUTPUT. Smart card (ISO7816) clock signal
	ISO7816_DATA	DIO			INPUT/OUTPUT. Smart card (ISO7816) I/O data signal.
	ISO7816_RST	DO			OUTPUT. Smart card (ISO7816) reset signal.
	ISO7816_CI	DI			INPUT. Smart card (ISO7816) inserted signal.
PCM Interface (mapped on port Px_yy)					
	PCM_DI	DI			INPUT. PCM input data.
	PCM_DO	DO			OUTPUT. PCM output data.
	PCM_FSC	DIO			INPUT/OUTPUT. PCM Frame synchronization.
	PCM_CLK	DIO			INPUT/OUTPUT. PCM Clock
PDM Interface (mapped on port Px_yy)					
	PDM_DATA	DIO			INPUT/OUTPUT. PDM data.
	PDM_CLK	DO			OUTPUT. PDM clock output.
Motor Controller Interface (mapped on port P0_yy)					
D8	PG0_1	DO			OUTPUT. Pattern Generator 0, Output 1.
D7	PG0_2	DO			OUTPUT. Pattern Generator 0, Output 2.

Multi-Core Bluetooth 5.2 SoC Family with System PMU

Ball No.	Pin name	Type	Drive (mA)	Reset state	Description
D6	PG0_3	DO			OUTPUT. Pattern Generator 0, Output 3.
D5	PG0_4	DO			OUTPUT. Pattern Generator 0, Output 4.
D4	PG1_1	DO			OUTPUT. Pattern Generator 1, Output 1.
D3	PG1_2	DO			OUTPUT. Pattern Generator 1, Output 2.
C4	PG1_3	DO			OUTPUT. Pattern Generator 1, Output 3.
C3	PG1_4	DO			OUTPUT. Pattern Generator 1, Output 4.
C8	PG2_1	DO			OUTPUT. Pattern Generator 2, Output 1.
C7	PG2_2	DO			OUTPUT. Pattern Generator 2, Output 2.
C6	PG2_3	DO			OUTPUT. Pattern Generator 2, Output 3.
C5	PG2_4	DO			OUTPUT. Pattern Generator 2, Output 4.
E1	PG3_1	DO			OUTPUT. Pattern Generator 3, Output 1.
E2	PG3_2	DO			OUTPUT. Pattern Generator 3, Output 2.
D1	PG3_3	DO			OUTPUT. Pattern Generator 3, Output 3.
D2	PG3_4	DO			OUTPUT. Pattern Generator 3, Output 4.
F1	PG4_1	DO			OUTPUT. Pattern Generator 4, Output 1.
F2	PG4_2	DO			OUTPUT. Pattern Generator 4, Output 2.
B6	PG4_3	DO			OUTPUT. Pattern Generator 4, Output 3.
B5	PG4_4	DO			OUTPUT. Pattern Generator 4, Output 4.
LCD Controller Interface					
	LCD_SPI_DC (Note 1)	DO			OUTPUT. LCD data/command select.
	LCD_SPI_DO (Note 1)	DO			OUTPUT. LCD SPI data output.
	LCD_SPI_CLK (Note 1)	DO			OUTPUT. LCD SPI clock.
	LCD_SPI_EN (Note 1)	DO			OUTPUT. LCD SPI clock enable (chip select).
F7	LCD_RED0 (Note 1)	DO			LCD Red image data output, bit 0.
F6	LCD_RED1 (Note 1)	DO			LCD Red image data output, bit 1.
E5	LCD_GREEN0 (Note 1)	DO			LCD Green image data output, bit 0.
E4	LCD_GREEN1 (Note 1)	DO			LCD Green image data output, bit 1.
E7	LCD_BLUE0 (Note 1)	DO			LCD Blue image data output, bit 0.
E6	LCD_BLUE1 (Note 1)	DO			LCD Blue image data output, bit 1.
H6, D7	PLCD_ENAB (Note 1)	DO			OUTPUT. Parallel LCD Indication signal for valid data on the LCD data bus.
H4, D5	PLCD_CLK (Note 1)	DO			OUTPUT. Parallel LCD Clock signal.
H3, D4	PLCD_HSYNC (Note 1)	DO			OUTPUT. Parallel LCD Indication signal for resetting the LCD column pointer to the edge of the display.
H5, D6	PLCD_VSYNC (Note 1)	DO			OUTPUT. Parallel LCD Indication signal for resetting the LCD row pointer to top of the display.

Ball No.	Pin name	Type	Drive (mA)	Reset state	Description
H6, D7	LCD_ENB (Note 1)	DO			OUTPUT. LCD Write enable signal for the pixel memory.
H3, D4	LCD_HST (Note 1)	DO			OUTPUT. LCD Start signal for the horizontal driver.
H4, D5	LCD_HCK (Note 1)	DO			OUTPUT. LCD Shift clock signal for the horizontal driver.
H5, D6	LCD_VST (Note 1)	DO			OUTPUT. LCD Start signal for the vertical driver.
J7, D3	LCD_XRST (Note 1)	DO			OUTPUT. LCD Reset signal for the horizontal and vertical driver.
H7, D8	LCD_VCK (Note 1)	DO			OUTPUT. LCD Shift clock for the vertical driver.
K8, C3	LCD_TE (Note 1)	DI			INPUT. LCD Tearing effect signal. Used to synchronize the CPU to the frame memory writing.
G7	LCD_VCOM/LCD_FRP (Note 1)	DO			OUTPUT. Combined LCD signals into a single pin: - VCOM: Common electrode driving signal (62.5 Hz). - FRP: Liquid crystal driving signal (62.5 Hz)
G7	LCD_EXTCOMIN (Note 1)	DO			OUTPUT. LCD COM Inversion Signal Input (1 Hz).
G6	LCD_XFRP (Note 1)	DO			OUTPUT. LCD Liquid crystal driving signal (62.5 Hz inverted).
Analog Interface					
G8	GPADC_0	AI			INPUT. Analog input for the general-purpose ADC, channel 0.
D9	GPADC_1	AI			INPUT. Analog input for the general-purpose ADC, channel 1.
B6	GPADC_2	AI			INPUT. Analog input for the general-purpose ADC, channel 2.
B5	GPADC_3	AI			INPUT. Analog input for the general-purpose ADC, channel 3.
H7	GPADC_4	AI			INPUT. Analog input for the general-purpose ADC, channel 4.
H8	GPADC_5	AI			INPUT. Analog input for the general-purpose ADC, channel 5.
J10	GPADC_6	AI			INPUT. Analog input for the general-purpose ADC, channel 6.
J9	GPADC_7	AI			INPUT. Analog input for the general-purpose ADC, channel 7.
G8	SDADC_0	AI			INPUT. Analog input for the $\Sigma\Delta$ ADC, channel 0.
D9	SDADC_1	AI			INPUT. Analog input for the $\Sigma\Delta$ ADC, channel 1.
B6	SDADC_2	AI			INPUT. Analog input for the $\Sigma\Delta$ ADC, channel 2.
B5	SDADC_3	AI			INPUT. Analog input for the $\Sigma\Delta$ ADC, channel 3.
H6	SDADC_4	AI			INPUT. Analog input for the $\Sigma\Delta$ ADC, channel 4.
J8	SDADC_5	AI			INPUT. Analog input for the $\Sigma\Delta$ ADC, channel 5.
J7	SDADC_6	AI			INPUT. Analog input for the $\Sigma\Delta$ ADC, channel 6.
K8	SDADC_7	AI			INPUT. Analog input for the $\Sigma\Delta$ ADC, channel 7.

Multi-Core Bluetooth 5.2 SoC Family with System PMU

Ball No.	Pin name	Type	Drive (mA)	Reset state	Description
B10	SDADC_GND	AI			INPUT. Analog input for the $\Sigma\Delta$ ADC reference ground.
C9	SDADC_REF	AI			INPUT. Analog input for the $\Sigma\Delta$ ADC reference voltage.
USB FS Interface					
K6	USBp	AIO			INPUT/OUTPUT. Analog USB Full Speed D+ signal.
K7	USBm	AIO			INPUT/OUTPUT. Analog USB Full Speed D- signal.
Haptic Driver Interface					
K4	HDRVM	AO			Negative haptic driver differential output.
J4	HDRVP	AO			Positive haptic-driver differential output.
Radio Interface					
A8	RFIOP	AIO			RF input/output. Impedance 50 Ω .
A7	RFIOM	AIO			RF Ground
Miscellaneous					
K10	LED1	AO			OUTPUT. LED 1 driver output (open drain, 20 mA maximum).
K9	LED2	AO			OUTPUT. LED 2 driver output (open drain, 20 mA maximum).
B9	NTC Input	AI			INPUT. Analog input for battery NTC (feedback).
E9	NTC Supply	AO			OUTPUT. Power supply for battery NTC sensor.
B8	RSTn	AI			INPUT. Reset signal (active LOW).
Power Supply					
J2	V12	AO			OUTPUT. 1.2 V power rail. 10 μ F decoupling capacitor required.
H1	V14	AIO			OUTPUT. 1.4 V power rail. 10 μ F decoupling capacitor required.
A5	VSUP_RF	AI			INPUT. Radio supply voltage. Connect to V14 externally. 10 μ F decoupling capacitor required.
G1	V18F	AIO			OUTPUT. 1.8 V power rail. Maximum current 50 mA. 0.1 μ F decoupling capacitor required. Connect to V18P externally.
G2	V18P	AIO			OUTPUT. 1.8 V power rail. Maximum current 50 mA. 22 μ F decoupling capacitor required.
H2	V18	AIO			OUTPUT. 1.8 V power rail. Maximum current 50 mA. 22 μ F decoupling capacitor required.
J6	V30	AIO			OUTPUT. 3.0 V power rail. Maximum current 150 mA. 4.7 μ F decoupling capacitor required.
K1	LX	AIO			INPUT/OUTPUT. Connection for the external DC-DC converter inductor.
J1	LY	AIO			INPUT/OUTPUT. Connection for the external DC-DC converter inductor.
K5	VBAT1	AIO			INPUT. Battery connection 1 for LDO supply.
K2	VBAT2	AIO			INPUT. Battery connection 2 for DC-DC converter supply.
J5	VBUS	AI AI			INPUT. USB bus voltage. INPUT. Battery charge voltage.
F5	AVS1	-			Analog Ground.

Ball No.	Pin name	Type	Drive (mA)	Reset state	Description
G5	AVS2	-			Analog Ground.
K3	BUCK GND	-			DCDC Converter Ground.
G3	VSSD1	-			Digital Ground.
G4	VSSD2	-			Digital Ground.
F4	VSSD3	-			Digital Ground.
F3	VSSD4	-			Digital Ground.
E3	VSSIOQ	-			QSPI Ground.
B7	ESDN	-			RF Ground.
A9	RFIOM2	-			RF Ground.
D10	GND_RF1	-			RF Ground.
C10	GND_RF2	-			RF Ground.
A10	PSUB_RF	-			RF Ground.
A6	PSUB	-			RF Ground.
J3	HDRV GND	-			Haptic Driver Ground

Note 1 Not applicable to all supported LCD Interfaces.

Note 2 Data input only. MOSI in SPI slave mode, MISO in SPI master mode.

Note 3 Data output only. MISO in SPI slave mode, MOSI in SPI master mode.

Note 4 RDS = Reduced Driving Strength functionality (PAD_WEAK_CTRL_REG).

Note 5 This pin can only be used as a GPIO in 1.8 V since it is a QSPI type of pad.

5. Specifications

All MIN/MAX specification limits are guaranteed by design, production testing and/or statistical characterization. Typical values are based on characterization results at default measurement conditions and are informative only. Default measurement conditions (unless otherwise specified): VBAT1 = VBAT2 = 3.0 V, T_A = 25 °C. All radio measurements are performed with standard RF measurement equipment providing a source/load impedance of 50 Ω.

The specified MIN and MAX capacitor values define the range of the effective capacitance, which may vary over the applied voltage due to voltage derating. Refer to the component manufacturer for the capacitor specifications.

5.1 Absolute Maximum Ratings

Table 4: Absolute maximum ratings

Parameter	Description	Conditions	Min	Max	Unit
V _{PIN_LIM_DEF}	Limiting voltage on a pin	Default, unless otherwise specified	-0.1	3.6	V
V _{BAT_LIM}	Limiting battery supply voltage	Pin V _{BAT}	0	6	V
V _{BUS_LIM}	Limiting bus supply voltage	Pin V _{BUS}	0	6.5	V
t _{R_SUP}	Power supply rise time			30	ms
V _{PIN_LIM_3V0}	Limiting voltage on a pin	3.0 V I/O pins	0	3.45	V
V _{PIN_LIM_1V8}	Limiting voltage on a pin	1.8 V I/O pins	0	1.98	V
V _{ESD_HBM_BGA100}	Electrostatic discharge voltage (Human Body Model)	VFBGA100 package		2200	V
V _{ESD_CDM_BGA100}	Electrostatic discharge voltage (Charged Device Model)	VFBGA100 package		500	V
T _{STG}	Storage temperature		-50	150	°C

5.2 Recommended Operating Conditions

Table 5: Recommended operating conditions

Parameter	Description	Conditions	Min	Typ	Max	Unit
V _{BAT}	Battery supply voltage	Pin V _{BAT1} and V _{BAT2}	2.4		4.75	V
V _{BAT_OTP(Prog ram)}	Battery supply voltage	Voltage range for OTP programming. Required temperature for programming is between -20°C and 85°C	2.4		4.75	V
V _{BAT_OTP(Read)}	Battery supply voltage	Voltage range for OTP reading	2.4		4.75	V
V _{BUS}	Bus supply voltage	Pin V _{BUS}	4.2		5.75	V
V _{PIN_3V0}	Voltage on a pin	3.0 V I/O pins	0		3	V
V _{PIN_1V8}	Voltage on a pin	1.8 V I/O pins	0		1.8	V
T _A	Ambient temperature		-40		85	°C

5.3 DC Characteristics

Table 6: DC characteristics

Parameter	Description	Conditions	Min	Typ	Max	Unit
I _{BAT_IDLE}	Battery supply current	CPU is idle (Wait for Interrupt - WFI); sys_clk = 32 MHz; pclk = 4 MHz; DC-DC on; FLASH off; peripherals on; V _{BAT} = 3 V.		0.8		mA

Multi-Core Bluetooth 5.2 SoC Family with System PMU

Parameter	Description	Conditions	Min	Typ	Max	Unit
I _{BAT_RUN_32MH} z	Average active battery supply current	CPU is executing code from RAM; sys_clk = 32 MHz; pclk = 4 MHz; DC-DC on; Peripherals off; V _{BAT} = 3 V.		1.8		mA
I _{BAT_RUN_48MH} z	Average active battery supply current	CPU is executing code from RAM; hclk = 48 MHz; PLL on; pclk = 6 MHz; DC-DC on; Peripherals off; V _{BAT} = 3 V.		5		mA
I _{BAT_RUN_96MH} z	Average active battery supply current	CPU is executing code from RAM; hclk = 96 MHz; PLL on; pclk = 12 MHz; DC-DC on; Peripherals off; V _{BAT} = 3 V.		7.8		mA
I _{BAT_HIBERN}	Battery supply current	Hibernation mode; no RAM retained; all clocks off; DC-DC off; V _{DD_clamp} setting 0xD at 25 °C FLASH off; V _{BAT} = 3 V. Note 2		6.8		μA
I _{BAT_DP_SLP}	Battery supply current	Deep Sleep mode; No RAM retained; XTAL32K on; RTC off; DC-DC off; V _{DD_RET} = 0.75 V; FLASH off; V _{BAT} = 3 V. Bandgap Refresh rate = 0x80		10		μA
I _{BAT_EX_SLP_1} 6K_64K	Battery supply current	Extended Sleep mode; 16 kB (Cache) and 64 kB (data) RAM retained; XTAL32K on; DC-DC off; V _{DD_RET} = 0.75 V; FLASH in Power Down mode; V _{BAT} = 3 V. Bandgap Refresh rate = 0x80; Note 3		12.3		μA
I _{BAT_EX_SLP_1} 6K_128K	Battery supply current	Extended Sleep mode; 16 kB (cache) and 128 kB (data) RAM retained; XTAL32K on; DC-DC off; V _{DD_RET} = 0.75 V; FLASH in Power Down mode; V _{BAT} = 3 V. Bandgap Refresh rate = 0x80; Note 3		13.1		μA
I _{BAT_EX_SLP_1} 6K_256K	Battery supply current	Extended Sleep mode; 16 kB (cache) and 256 kB (data) RAM retained; XTAL32K on; DC-DC off; V _{DD_RET} = 0.75 V; FLASH in Power Down mode; V _{BAT} = 3 V. Bandgap Refresh rate = 0x80; Note 3		14.9		μA

Multi-Core Bluetooth 5.2 SoC Family with System PMU

Parameter	Description	Conditions	Min	Typ	Max	Unit
I _{BAT_EX_SLP_1} 6K_384K	Battery supply current	Extended Sleep mode; 16 kB (cache) and 384 kB (data) RAM retained; XTAL32K on; DC-DC off; V _{DD_RET} = 0.75 V; FLASH in Power Down mode; V _{BAT} = 3 V. Bandgap Refresh rate = 0x80; Note 3		16.7		μA
I _{BAT_EX_SLP_1} 6K_512K	Battery supply current	Extended Sleep mode; 16 kB (cache) and 512 kB (data) RAM retained; XTAL32K on; DC-DC off; V _{DD_RET} = 0.75 V; FLASH in Power Down mode; V _{BAT} = 3 V. Bandgap Refresh rate = 0x80; Note 3		18.4		μA
I _{BAT_GearBox}	Average battery supply current	Gear Box control mode for moving seconds (every 330 ms) and minutes (every 20 sec) hands; RTC on; PD_PER on; RTC will wake up SNC.SNC will trigger Motor Controller to deliver 9 ms waveforms on GPIOs (at 1.8 V) and go back to sleep. ARM M33 kept off constantly.		74		μA
I _{BAT_SensorNode}	Average battery supply current	Sensor Node Controller reading from SPI at 4 MHz, 8-bit at 1.8 V; Running at RC32M; XTAL32M = off; Hclk = 8 MHz; Pclk = 2 MHz; DC-DC on; CPU off; FLASH in Power Down mode; V _{BAT} = 3 V.		1.1		mA
I _{BAT_BLE_RX_32M}	Peak battery supply current	Bluetooth® LE receive mode; f _{CLK} = 32 MHz; CPU idle; DC-DC on; FLASH off; V _{BAT} = 3 V.		4.9		mA
I _{BAT_BLE_TX_32M}	Peak battery supply current	Bluetooth® LE transmit mode @ 0dbm; f _{CLK} = 32 MHz; CPU idle; DC-DC on; FLASH off; V _{BAT} = 3 V.		5.8		mA
I _{BAT_BLE_RX_96M}	Peak battery supply current	Bluetooth® LE receive mode; f _{CLK} = 96 MHz; CPU idle; DC-DC on; FLASH off; V _{BAT} = 3 V.		7		mA
I _{BAT_BLE_TX_96M}	Peak battery supply current	Bluetooth® LE transmit mode @ 0dbm; f _{CLK} = 96 MHz; CPU idle; DC-DC on; FLASH off; V _{BAT} = 3 V.		7.8		mA

Note 2 At temperatures higher than 55 °C, a higher voltage setting (0xC) should be applied at the clamp to ensure proper hibernation operation

Note 3 If RTC is on then 150 nA should be added

5.4 Timing Characteristics

Table 7: Timing characteristics

Parameter	Description	Conditions	Min	Typ	Max	Unit
t _{STA_SLOW}	Supply startup time	Time from wake up GPIO toggle up to application SW execution start. All voltage levels are checked prior enabling the CPU			600	μs
t _{STA_FAST}	Supply startup time	Time from wake up GPIO toggle up to application SW execution start. Core (VDD) and Radio (V14) voltages checked prior enabling the CPU			300	μs
t _{STA_ULTRA_FAST}	Supply startup time	Time from wake up GPIO toggle up to application SW execution start. All voltage levels are assumed ok prior enabling the CPU			120	μs
t _{STA_BOOT}	Power up to booter executed, startup time	BootROM code execution time without authentication. Max. value when in "development mode", min. value when in "Normal" mode.	8		50	ms
t _{CLF_OTP}	Cache line fetch time	From OTP; line size = 8 B			6	clock
t _{CLF_FLASH}	Cache line fetch time	From FLASH; line size = 8 B			40	clock

5.5 Thermal Characteristics

Table 8: Thermal characteristics

Parameter	Description	Conditions	Min	Typ	Max	Unit
R _{θJA_P1_HQ}	Thermal resistance (junction to ambient θ _{dJA} (n))	VFBGA86 package. JEDEC PCB, 0.1W+0.3W Power map		48.8		°C/W
R _{θJA_P2_HR}	Thermal resistance (junction to ambient θ _{dJA} (n))	VFBGA100 package. JEDEC PCB, 0.1W+0.3W Power map		48.8		°C/W

5.6 Reset Characteristics

Table 9: PAD_RESET - DC characteristics

Parameter	Description	Conditions	Min	Typ	Max	Unit
I _{IL_PU_RSTN}	LOW level input current with pull-up	Pin RESET _n , V _I = 0.0 V	-75		-25	μA
V _{IH_RSTN}	HIGH level input voltage	Pin RESET _n , V _{I2} = 1.2 V	0.7*V _{I2}			V
V _{IL_RSTN}	LOW level input voltage	Pin RESET _n , V _{I2} = 1.2 V			0.3*V _{I2} 2	V

5.7 Bandgap Characteristics

Table 10: BG_REF - DC characteristics

Parameter	Description	Conditions	Min	Typ	Max	Unit
V _{BG_REF}	Bandgap reference voltage from GPADC reference buffer		1.14	1.2	1.26	V
V _{ACC_TRIM}	Voltage accuracy	After trimming			1.2	%
I _{BG_IREF_CUR_TRIM}	Internal bandgap reference trim test current		13	15	16	μA

5.8 Brown-Out Detector Characteristics

Table 11: BOD - DC characteristics

Parameter	Description	Conditions	Min	Typ	Max	Unit
V _{RST_VDD_sleep}	Reset voltage	BOD_LVL_VDD_RET = 0x6F	0.67	0.7	0.73	V
V _{RST_VDD}	Reset voltage	BOD_LVL_VDD_ON = 0xA7	1.02	1.05	1.08	V
V _{RST_V14}	Reset voltage	BOD_LVL_V14 = 0xC7	1.21	1.25	1.29	V
V _{RST_V18P}	Reset voltage	BOD_LVL_V18P = 0x107	1.61	1.65	1.69	V
V _{RST_V18F}	Reset voltage	BOD_LVL_V18F = 0x107	1.61	1.65	1.69	V
V _{RST_V18}	Reset voltage	BOD_LVL_V18 = 0x107	1.61	1.65	1.69	V
V _{RST_V30}	Reset voltage	BOD_LVL_V30 = 0x137	1.91	1.95	1.99	V
V _{RST_VBAT}	Reset voltage	BOD_LVL_VBAT = 0xF4	2.24	2.3	2.36	V

5.9 General Purpose ADC Characteristics

Table 12: GP_ADC - Recommended operating conditions

Parameter	Description	Conditions	Min	Typ	Max	Unit
N _{BIT_ADC}	Number of bits (resolution)			10		bit

Table 13: GP_ADC - DC characteristics

Parameter	Description	Conditions	Min	Typ	Max	Unit
E _G	Gain error without calibration	Trimmed bandgap	-3		3	%
E _{G_CALIBRATED}	Gain error after calibration	Trimmed bandgap & Gain Error + Offset correction applied	-1		1	%
E _{OFS}	Offset error without calibration	Trimmed bandgap LSB wrt 10bit accuracy	-20		20	LSB

Parameter	Description	Conditions	Min	Typ	Max	Unit
E _{OFS_CALIBRATED}	Offset error after calibration	Trimmed bandgap & Gain Error + Offset correction applied LSB wrt 10bit accuracy	-7		4	LSB
E _{G_ATT3x}	Gain error of the 3x attenuator	Trimmed bandgap & GPADC Gain Error + Offset correction applied	-4		1	%
E _{G_VBAT}	Gain error of the VBAT attenuator	Trimmed bandgap & GPADC Gain Error + Offset correction applied		-1.7		%
INL	Integral non-linearity	LSB wrt 10bit accuracy	-2		2	LSB
DNL	Differential non-linearity	LSB wrt 10bit accuracy	-2		2	LSB
ENOB	Effective Number Of Bits	No averaging, no chopping, Single-Ended: V _{IN,PP} = 1.1 V		9		bit
ENOB _{AVG128}	Effective Number Of Bits	128x averaging, Single-Ended: V _{IN,PP} = 1.1 V		10.5		bit

Table 14: GP_ADC - Timing characteristics

Parameter	Description	Conditions	Min	Typ	Max	Unit
t _{CONV_ADC}	Conversion time	Single conversion (CONV_NRS = 0, CHOP = 0), maximum sampling time (SMPL_TIME = 15), maximum store delay (STORE_DEL = 15), and including initial LDO settling (20 us)		55		μs

5.10 ΣΔ ADC Characteristics

Table 15: SD_ADC - DC characteristics

Parameter	Description	Conditions	Min	Typ	Max	Unit
C _{IN}	Input capacitance			192		fF
INL _{ext_ref}	Integral non-linearity Note 2	LSB wrt 14b accuracy	-4		4	LSB
DNL _{ext_ref}	Differential non-linearity	LSB wrt 14b accuracy	-4		4	LSB
E _{G_ext_ref}	Gain error	Using external voltage reference 1.2 V	-0.25		0.25	%
E _{OFS_ext_ref}	Offset error	LSB wrt 14b accuracy. Using external voltage reference 1.2 V	-2		2	LSB

Note 2 INL is the deviation of a code from a straight line passing through the actual endpoints of the transfer curve.

Table 16: SD_ADC - Electrical performance

Parameter	Description	Conditions	Min	Typ	Max	Unit
SFDR_ext_ref	Spurious-free dynamic range		74			dB
SNR_ext_ref	Signal to noise ratio		74			dB

5.11 DC-DC Converter Characteristics

Table 17: DCDC - Recommended operating conditions

Parameter	Description	Conditions	Min	Typ	Max	Unit
I _{L1V8}	Load Current				50	mA
I _{L1V8P}	Load Current				50	mA

Table 18: DCDC - DC characteristics

Parameter	Description	Conditions	Min	Typ	Max	Unit
I _Q	Quiescent Current	No load		180		μA
V _{O1V2_0}	VDD1V2 Output Voltage	VDD_LEVEL = 0	0.85	0.9	0.95	V
V _{O1V2_1}	VDD1V2 Output Voltage	VDD_LEVEL = 1	0.95	1	1.05	V
V _{O1V2_2}	VDD1V2 Output Voltage	VDD_LEVEL = 2	1.05	1.1	1.15	V
V _{O1V2_3}	VDD1V2 Output Voltage	VDD_LEVEL = 3	1.15	1.2	1.25	V
V _{RPL1V2_TYP}	VDD1V2 Peak-to-Peak Ripple Voltage	V _{BAT} = 3.0 V, I _{VDD1V2} = 5 mA, I _{VDD1V4} = 5 mA, I _{VDD1V8P} = 2 mA, I _{VDD1V8} = 0 mA		10	50	mV
V _{O1V4_0}	VDD1V4 Output Voltage	V14_LEVEL = 0	1.15	1.2	1.25	V
V _{O1V4_1}	VDD1V4 Output Voltage	V14_LEVEL = 1	1.2	1.25	1.3	V
V _{O1V4_2}	VDD1V4 Output Voltage	V14_LEVEL = 2	1.25	1.3	1.35	V
V _{O1V4_3}	VDD1V4 Output Voltage	V14_LEVEL = 3	1.3	1.35	1.4	V
V _{O1V4_4}	VDD1V4 Output voltage	V14_LEVEL = 4	1.35	1.4	1.45	V
V _{O1V4_5}	VDD1V4 Output Voltage	V14_LEVEL = 5	1.4	1.45	1.5	V
V _{O1V4_6}	VDD1V4 Output Voltage	V14_LEVEL = 6	1.45	1.5	1.55	V
V _{O1V4_7}	VDD1V4 Output Voltage	V14_LEVEL = 7	1.5	1.55	1.6	V
V _{RPL1V4_TYP}	VDD1V4 Peak-to-Peak Ripple Voltage	V _{BAT} = 3.0 V, I _{VDD1V2} = 5 mA, I _{VDD1V4} = 5 mA, I _{VDD1V8P} = 2 mA, I _{VDD1V8} = 0 mA		5	20	mV
V _{O1V8_0}	VDD1V8 Output Voltage	V18_LEVEL = 0	1.1	1.2	1.25	V
V _{O1V8_1}	VDD1V8 Output Voltage	V18 LEVEL = 1	1.7	1.8	1.9	V
V _{RPL1V8_TYP}	VDD1V8P Peak-to-Peak Ripple Voltage	V _{BAT} = 3.0 V, I _{VDD1V2} = 5 mA, I _{VDD1V4} = 5 mA, I _{VDD1V8P} = 2 mA, I _{VDD1V8} = 0 mA		5	50	mV

Multi-Core Bluetooth 5.2 SoC Family with System PMU

Parameter	Description	Conditions	Min	Typ	Max	Unit
V _{RPL_1V8_EXT_LOAD_1}	VDD1V8P Peak-to-Peak Ripple Voltage	V _{BAT} = 3.0 V, I _{VDD1V2} = 5 mA, I _{VDD1V4} = 5 mA, I _{VDD1V8P} = 5 mA, I _{VDD1V8} = 5 mA		10	50	mV
V _{RPL_1V8_EXT_LOAD_2}	VDD1V8P Peak-to-Peak Ripple Voltage	V _{BAT} = 3.0 V, I _{VDD1V2} = 5 mA, I _{VDD1V4} = 5 mA, I _{VDD1V8P} = 15 mA, I _{VDD1V8} = 15 mA		15	50	mV
V _{RPL_1V8_EXT_LOAD_3}	VDD1V8P Peak-to-Peak Ripple Voltage	V _{BAT} = 3.0 V, I _{VDD1V2} = 5 mA, I _{VDD1V4} = 5 mA, I _{VDD1V8P} = 50 mA, I _{VDD1V8} = 50 mA		35	50	mV
V _{O_1V8P}	VDD1V8P Output Voltage		1.7	1.8	1.9	V
V _{RPL_1V8P_TYP}	VDD1V8 Peak-to-Peak Ripple Voltage	V _{BAT} = 3.0 V, I _{VDD1V2} = 5 mA, I _{VDD1V4} = 5 mA, I _{VDD1V8P} = 2 mA, I _{VDD1V8} = 0 mA		5	50	mV
V _{RPL_1V8P_EX_T_LOAD_1}	VDD1V8 Peak-to-Peak Ripple Voltage	V _{BAT} = 3.0 V, I _{VDD1V2} = 5 mA, I _{VDD1V4} = 5 mA, I _{VDD1V8P} = 5 mA, I _{VDD1V8} = 5 mA		10	50	mV
V _{RPL_1V8P_EX_T_LOAD_2}	VDD1V8 Peak-to-Peak Ripple Voltage	V _{BAT} = 3.0 V, I _{VDD1V2} = 5 mA, I _{VDD1V4} = 5 mA, I _{VDD1V8P} = 15 mA, I _{VDD1V8} = 15 mA		15	50	mV
V _{RPL_1V8P_EX_T_LOAD_3}	VDD1V8 Peak-to-Peak Ripple Voltage	V _{BAT} = 3.0 V, I _{VDD1V2} = 5 mA, I _{VDD1V4} = 5 mA, I _{VDD1V8P} = 50 mA, I _{VDD1V8} = 50 mA		35	50	mV
η _{CONV_1V8_TYP}	Conversion Efficiency	V _{BAT} = 3.0 V, I _{VDD1V2} = 5 mA, I _{VDD1V4} = 5 mA, I _{VDD1V8P} = 2 mA, I _{VDD1V8} = 0 mA		80		%
η _{CONV_1V8_EX_T_LOAD_1}	Conversion Efficiency	V _{BAT} = 3.0 V, I _{VDD1V2} = 5 mA, I _{VDD1V4} = 5 mA, I _{VDD1V8P} = 5 mA, I _{VDD1V8} = 5 mA		80		%
η _{CONV_1V8_EX_T_LOAD_2}	Conversion Efficiency	V _{BAT} = 3.0 V, I _{VDD1V2} = 5 mA, I _{VDD1V4} = 5 mA, I _{VDD1V8P} = 15 mA, I _{VDD1V8} = 15 mA		85		%
η _{CONV_1V8_EX_T_LOAD_3}	Conversion Efficiency	V _{BAT} = 3.0 V, I _{VDD1V2} = 5 mA, I _{VDD1V4} = 5 mA, I _{VDD1V8P} = 50 mA, I _{VDD1V8} = 50 mA		80		%
η _{CONV_1V8P_TYP}	Conversion Efficiency	V _{BAT} = 3.0 V, I _{VDD1V2} = 5 mA, I _{VDD1V4} = 5 mA, I _{VDD1V8P} = 2 mA, I _{VDD1V8} = 0 mA		80		%
η _{CONV_1V8P_EX_T_LOAD_1}	Conversion Efficiency	V _{BAT} = 3.0 V, I _{VDD1V2} = 5 mA, I _{VDD1V4} = 5 mA, I _{VDD1V8P} = 5 mA, I _{VDD1V8} = 5 mA		80		%
η _{CONV_1V8P_EX_T_LOAD_2}	Conversion Efficiency	V _{BAT} = 3.0 V, I _{VDD1V2} = 5 mA, I _{VDD1V4} = 5 mA, I _{VDD1V8P} = 15 mA, I _{VDD1V8} = 15 mA		85		%
η _{CONV_1V8P_EX_T_LOAD_3}	Conversion Efficiency	V _{BAT} = 3.0 V, I _{VDD1V2} = 5 mA, I _{VDD1V4} = 5 mA, I _{VDD1V8P} = 50 mA, I _{VDD1V8} = 50 mA		80		%

5.12 LDOs Characteristics

Table 19: LDO_1v8 - Recommended operating conditions

Parameter	Description	Conditions	Min	Typ	Max	Unit
I _{L_LDO_1v8}	Load current	(V _{IN} - V _{OUT}) > 400 mV; I _L MAX = 45 mA for 200 mV < (V _{IN} - V _{OUT}) < 400 mV.	0		50	mA
C _{L_LDO_1v8}	Effective load capacitance		1		100	μF
ESR _{CL_LDO_1v8}	Equivalent series resistance		0		100	mΩ

Table 20: LDO_1v8 - DC characteristics

Parameter	Description	Conditions	Min	Typ	Max	Unit
V _{DROP_1v8_MAX}	Maximum dropout voltage	I _L = 45 mA; V _{DROP} > 400 mV for 45 mA < I _L < 50 mA			200	mV
V _{LDO_1v8_0}	LDO output voltage		1.14	1.2	1.25	V
V _{LDO_1v8_1}	LDO output voltage		1.7	1.8	1.9	V
REG _{LOAD}	Load regulation (((ΔV _O /V _O)*100%)/ΔI _L)	10 mA < I _{LOAD} < 50 mA when (V _{IN} - V _{OUT}) > 400 mV. 10 mA < I _{LOAD} < 45 mA when 200 mV < (V _{IN} -V _{OUT}) < 400 mV.	-0.03		0.03	%/mA
REG _{LINE}	Line regulation (((ΔV _O /V _O)*100%)/ΔV _I)	V _{IN} -V _{OUT} > 400 mV	-0.8		0.8	%/V

Table 21: LDO_1v8 - AC characteristics

Parameter	Description	Conditions	Min	Typ	Max	Unit
PSRR _{LDO_1v8}	Power supply rejection ratio	f ≤ 200 kHz. 5 mA < I _{LOAD} < 50 mA when (V _{IN} - V _{OUT}) > 400 mV. 5 mA < I _{LOAD} < 45 mA when 200 mV < (V _{IN} -V _{OUT}) < 400 mV.	30			dB

Table 22: LDO_1v8_RET - Recommended operating conditions

Parameter	Description	Conditions	Min	Typ	Max	Unit
I _{L_LDO_1v8_RET}	Load current	V ₃₀ must be > 2.2 V for maximum output current			10	mA
C _{L_LDO_1v8_RET}	Effective load capacitance		2.2		100	μF

Table 23: LDO_1v8_RET - DC characteristics

Parameter	Description	Conditions	Min	Typ	Max	Unit
V _{LDO_1V8_RET_0}	LDO output voltage V _{OUT} nom = 1.2 V	V ₃₀ = 3.1 V I _{LOAD} = 1 mA	1.15	1.2	1.25	V
V _{LDO_1V8_RET_1}	LDO output voltage V _{out} nom = 1.8 V	V ₃₀ = 3.1 V I _{LOAD} = 1 mA	1.7	1.8	1.9	V
REG _{LOAD}	Load regulation (((ΔV _O /V _O)*100%)/ΔI _L	1 mA < I _{LOAD} < 10 mA V _i ≥ 2.2 V	-0.12		0.12	%/mA
REG _{LINE}	Line regulation (((ΔV _O /V _O)*100%)/ΔV _i	V _i ≥ (V _o + 400 mV) V _{OUT} = 1.8 or 1.2 V, I _{LOAD} = 10 mA ΔV _i = 0.8 V	-1.8		1.8	%/V

Table 24: LDO_1V8P - Recommended operating conditions

Parameter	Description	Conditions	Min	Typ	Max	Unit
I _{L_LDO_1v8p}	Load current	(V _{IN} - V _{OUT}) > 400 mV; I _L MAX = 45 mA for 200 mV < (V _{IN} - V _{OUT}) < 400 mV.	0		50	mA
C _{L_LDO_1v8p}	Effective load capacitance		1		100	μF
ESR _{CL_LDO_1v8p}	Equivalent series resistance		0		100	mΩ

Table 25: LDO_1V8P - DC characteristics

Parameter	Description	Conditions	Min	Typ	Max	Unit
V _{DROP_1v8p_MAX}	Maximum dropout voltage	I _L = 45 mA; V _{DROP} > 400 mV for 45 mA < I _L < 50 mA			200	mV
V _{LDO_1V8P}	LDO output voltage	V ₃₀ = 3.0 V V _{18P} = unloaded	1.7	1.8	1.9	V
REG _{LOAD}	Load regulation (((ΔV _O /V _O)*100%)/ΔI _L	10 mA < I _{LOAD} < 50 mA when (V _{IN} - V _{OUT}) > 400 mV. 10 mA < I _{LOAD} < 45 mA when 200 mV < (V _{IN} -V _{OUT}) < 400 mV.	-0.03		0.03	%/mA
REG _{LINE}	Line regulation (((ΔV _O /V _O)*100%)/ΔV _i	(V _{IN} - V _{OUT}) > 400 mV	-0.5		0.5	%/V

Table 26: LDO_1V8P - AC characteristics

Parameter	Description	Conditions	Min	Typ	Max	Unit
PSRR _{LDO_1V8P}	Power supply rejection ratio	f ≤ 200 kHz. 5 mA < I _{LOAD} < 50 mA when (V _{IN} - V _{OUT}) > 400 mV. 5 mA < I _{LOAD} < 45 mA when 200 mV < (V _{IN} -V _{OUT}) < 400 mV.	40			dB

Table 27: LDO_1V8P_RET - Recommended operating conditions

Parameter	Description	Conditions	Min	Typ	Max	Unit
I _{L_LDO_1V8P_RET}	Load current	V ₃₀ must be > 2.4 V for maximum load current			10	mA
C _{L_LDO_1V8P_RET}	Effective load capacitance		2.2		100	μF

Table 28: LDO_1V8P_RET - DC characteristics

Parameter	Description	Conditions	Min	Typ	Max	Unit
V _{LDO_1V8P_RET}	LDO output voltage	I _{LOAD} = 1 mA V _i ≥ (V _o + 400 mV)	1.7	1.8	1.9	V
REG _{LOAD}	Load regulation	1 mA < I _{LOAD} < 10 mA V _i ≥ 2.2 V	-0.12		0.12	%/mA
REG _{LINE}	Line regulation (((ΔV _o /V _o)*100%)/ΔV _i	V _i ≥ (V _o + 400 mV) V _{OUT} = 1.8 V, I _{LOAD} = 10 mA	-1.8		1.8	%/V

Table 29: LDO_CORE - Recommended operating conditions

Parameter	Description	Conditions	Min	Typ	Max	Unit
I _{L_LDO_CORE}	Load current		0		50	mA
C _{L_LDO_CORE}	Load capacitance		1		100	μF
ESR _{CL_LDO_CORE}	Equivalent series resistance		0		100	mΩ

Table 30: LDO_CORE - DC characteristics

Parameter	Description	Conditions	Min	Typ	Max	Unit
V _{LDO_CORE_0}	LDO output voltage	V ₃₀ = 3.0 V I _{LOAD} = 1 mA	0.85	0.9	0.95	V
V _{LDO_CORE_1}	LDO output voltage	V ₃₀ = 3.0 V I _{LOAD} = 1 mA	0.95	1	1.05	V
V _{LDO_CORE_2}	LDO output voltage	V ₃₀ = 3.0 V I _{LOAD} = 1 mA	1.04	1.1	1.16	V
V _{LDO_CORE_3}	LDO output voltage	V ₃₀ = 3.0 V I _{LOAD} = 1 mA	1.14	1.2	1.26	V

Multi-Core Bluetooth 5.2 SoC Family with System PMU

Parameter	Description	Conditions	Min	Typ	Max	Unit
REG _{LOAD}	Load regulation ((($\Delta V_o/V_o$) [*] 100%)/ ΔI_L)	V ₃₀ = 3.0 V 1 mA ≤ I _{LOAD} ≤ 50 mA	-0.06		0.06	%/mA
REG _{LINE}	Line regulation ((($\Delta V_o/V_o$) [*] 100%)/ ΔV_i)	1.75 V < V ₃₀ < 3 V 1 mA ≤ I _{LOAD} ≤ 50 mA	-0.5		0.5	%/V
V _{DROP_LDO_CORE}	Dropout voltage (headroom)	I _L = 50 mA			450	mV

Table 31: LDO_CORE_RET - Recommended operating conditions

Parameter	Description	Conditions	Min	Typ	Max	Unit
CL _{CORE_RET}	Effective load capacitance		1		100	μF

Table 32: LDO_CORE_RET - DC characteristics

Parameter	Description	Conditions	Min	Typ	Max	Unit
REG _{LINE}	Line regulation ((($\Delta V_o/V_o$) [*] 100%)/ ΔV_i)	I _{LOAD} = 3 mA 1.75 V < V _{IN} < 3.45 V V _{OUT} = 0.75 V or 1.0 V	-0.5		0.5	%/V
REG _{LOAD}	Load regulation ((($\Delta V_o/V_o$) [*] 100%)/ ΔI_L)	V ₃₀ = 3.45 V 1 mA < I _{LOAD} < 3 mA V _{OUT} is 0.75 V or 1 V	-0.1		0.1	%/mA
V _{LDO_CORE_RET_0v75}	LDO output voltage V _{out} = 0.75 V	I _{LOAD} = 1 mA V _{IN} = 3.45 V	0.68	0.75	0.84	V
V _{LDO_CORE_RET_0v8}	LDO output voltage	I _{LOAD} = 1 mA V _{IN} = 3.45 V	0.72	0.8	0.89	V
V _{LDO_CORE_RET_0v85}	LDO output voltage	I _{LOAD} = 1 mA V _{IN} = 3.45 V	0.77	0.85	0.94	V
V _{LDO_CORE_RET_0v9}	LDO output voltage V _{out} = 0.9 V	I _{LOAD} = 1 mA V _{IN} = 3.45 V	0.82	0.9	0.99	V

Table 33: LDO_USB - Recommended operating conditions

Parameter	Description	Conditions	Min	Typ	Max	Unit
I _{L_LDO_USB}	Load current				150	mA
CL _{LDO_USB}	Load capacitance	Shared output pin with retention LDO (which needs a minimum cap of 2.2 μF)	2.2		100	μF
ESR _{CL_LDO_USB}	Equivalent series resistance		0		100	mΩ

Table 34: LDO_USB - DC characteristics

Parameter	Description	Conditions	Min	Typ	Max	Unit
V _{LDO_USB_0}	LDO output voltage		2.81	3	3.15	V

Multi-Core Bluetooth 5.2 SoC Family with System PMU

Parameter	Description	Conditions	Min	Typ	Max	Unit
V _{LDO_USB_2}	LDO output voltage		3.05	3.3	3.47	V
REG _{LOAD}	Load regulation ((($\Delta V_o/V_o$) [*] 100%)/ ΔI_L)	10 mA < I _{LOAD} < 150 mA	-0.03		0.03	%/mA
REG _{LINE}	Line regulation ((($\Delta V_o/V_o$) [*] 100%)/ ΔV_i)	I _{LOAD} = 150 mA V _{IN} > V _{OUT} + 800 mV	-2		2	%/V

Table 35: LDO_VBAT - Recommended operating conditions

Parameter	Description	Conditions	Min	Typ	Max	Unit
I _{L_LDO_VBAT}	Load current				150	mA
C _{L_LDO_VBAT}	Effective load capacitance	Shared output pin with retention LDO (which needs a minimum cap of 2.2 uF)	1		100	μF
ESR _{CL_LDO_VBAT}	Equivalent series resistance		0		100	mΩ

Table 36: LDO_VBAT - DC characteristics

Parameter	Description	Conditions	Min	Typ	Max	Unit
I _{Q_LDO_VBAT}	Quiescent current	No Load		65		μA
V _{LDO_VBAT_0}	Output voltage	V _{BAT} = 4.2 V V ₃₀ = Unloaded	2.8	3	3.15	V
V _{LDO_VBAT_2}	Output voltage	V _{BAT} = 4.2 V V ₃₀ = Unloaded	3.05	3.3	3.47	V
REG _{LOAD}	Load regulation ((($\Delta V_o/V_o$) [*] 100%)/ ΔI_L)	10 mA < I _{LOAD} < 150 mA	-0.03		0.03	%/mA
REG _{LINE}	Line regulation ((($\Delta V_o/V_o$) [*] 100%)/ ΔV_i)	I _{LOAD} 150 mA V _i ≥ (V _o + 400 mV)	-0.5		0.5	%/V

Table 37: LDO_VBAT_RET - Recommended operating conditions

Parameter	Description	Conditions	Min	Typ	Max	Unit
I _{L_LDO_VBAT_RET}	Load current				10	mA
C _{L_LDO_VBAT}	Effective load capacitance		2.2		100	μF

Table 38: LDO_VBAT_RET - DC characteristics

Parameter	Description	Conditions	Min	Typ	Max	Unit
V _{LDO_VBAT_RET_0}	Output voltage	V _{IN} 4.2 V; V _{OUT} = Unloaded	2.85	3	3.15	V
V _{LDO_VBAT_RET_2}	Output voltage	V _{IN} = 4.2 V; V _{OUT} = Unloaded	3.02	3.3	3.56	V
I _{Q_LDO_VBAT_RET}	Quiescent current	Unloaded		80		nA

Parameter	Description	Conditions	Min	Typ	Max	Unit
REG _{LOAD}	Load regulation ((($\Delta V_o/V_o$) [*] 100%)/ ΔI_L)	1 mA < I _{LOAD} < 10 mA	-0.07		0.07	%/mA
REG _{LINE}	Line regulation ((($\Delta V_o/V_o$) [*] 100%)/ ΔV_i)	V _{IN} - V _{OUT} > 450 mV I _{LOAD} = (I _{int} +3 mA)	-0.5		0.5	%/V
V _{DROP}	Maximum dropout voltage	I _{LOAD} = = 10 mA			450	mV

5.13 32 kHz Crystal Oscillator Characteristics

Table 39: OSC_XTAL32K - Recommended operating conditions

Parameter	Description	Conditions	Min	Typ	Max	Unit
f _{CLK_EXT_32K}	External clock frequency	At pin XTAL32KP/P0_23 in GPIO mode	31		33	kHz
f _{XTAL_32K}	Crystal oscillator frequency			32.768		kHz
ESR _{32K}	Equivalent series resistance				100	kΩ
C _{L_32K}	Load capacitance	No external capacitors are required for a 6 pF or 7 pF crystal.	6	7	9	pF
C _{0_32K}	Shunt capacitance			1	2	pF
Δf _{XTAL_32K}	Crystal frequency tolerance (including aging)	Timing accuracy is dominated by crystal accuracy. A much smaller value is preferred.	-250		250	ppm
P _{DRV_MAX_32K}	Maximum drive power	Note 2	0.1			μW

Note 2 Select a crystal that can handle a drive level of at least this specification.

Table 40: OSC_XTAL32K - DC characteristics

Parameter	Description	Conditions	Min	Typ	Max	Unit
V _{IH_EXT_CLK_32K}	HIGH level input voltage	at pin XTAL32KP/P0_23 in GPIO input mode; XTAL32K disabled Note 2	0.84			V
V _{IL_EXT_CLK_32K}	LOW level input voltage	At pin XTAL32KP/P0_23 in GPIO input mode; XTAL32K disabled Note 2			0.36	V

Note 2 Maximum input voltage of GPIO pins applies.

Table 41: OSC_XTAL32K - Timing characteristics

Parameter	Description	Conditions	Min	Typ	Max	Unit
t _{STA_XTAL_32K}	Crystal oscillator startup time	Typical application, time until 1000 clocks are detected.		400		ms

5.14 32 MHz Crystal Oscillator Characteristics

Table 42: OSC_XTAL32MEG - Recommended operating conditions

Parameter	Description	Conditions	Min	Typ	Max	Unit
$f_{XTAL(32M)}$	Crystal oscillator frequency			32		MHz
ESR(32M)	Equivalent series resistance				100	Ω
$C_L(32M)$	Load capacitance	No external capacitors are required	4	6	8	pF
$C_0(32M)$	Shunt capacitance				7	pF
$\Delta f_{XTAL(32M)}$	Crystal frequency tolerance	After optional trimming; including aging and temperature drift Note 2	-20		20	ppm
$\Delta f_{XTAL(32M) UNT}$	Crystal frequency tolerance	Untrimmed; including aging and temperature drift Note 3	-40		40	ppm

Note 2 Using the internal varicaps a wide range of crystals can be trimmed to the required tolerance.

Note 3 Maximum allowed frequency tolerance for compensation by the internal varicap trimming mechanism.

5.15 RCX Oscillator Characteristics

Table 43: OSC_RCX - Timing characteristics

Parameter	Description	Conditions	Min	Typ	Max	Unit
$\Delta f_{RC}/\Delta T$		For temperature ranging from -40°C to 85°C	-100		100	ppm/deg
$\Delta f_{RC}/\Delta V$		Battery Voltage	0		1100	ppm/V
f_{RCX}	RC oscillator frequency	At target fixed trim setting	13	15	18	kHz

5.16 32MHz RC Oscillator Characteristics

Table 44: OSC_RC32MEG - Timing characteristics

Parameter	Description	Conditions	Min	Typ	Max	Unit
$f_{RC32M_TRIMMED}$	RC oscillator frequency	At target trimming	30.6	31.5	32.6	MHz

5.17 PLL Characteristics

Table 45: PLL_SYS - DC characteristics

Parameter	Description	Conditions	Min	Typ	Max	Unit
I_{SUP}	PLL operating current	Calculation: $I_{SUP} = I_{PLL_TOT} - I_{PLL_REF}$	0.2	0.4	0.5	mA

Table 46: PLL_SYS - Timing characteristics

Parameter	Description	Conditions	Min	Typ	Max	Unit
t _{LOCK}	Frequency settling time	200 ppm accuracy		30	100	μs

5.18 Charger Characteristics

Table 47: Charger - DC characteristics

Parameter	Description	Conditions	Min	Typ	Max	Unit
V _{DROP}	Dropout voltage (VBUS - VBAT)	Max. charge current	800			mV
I _{CHARGE_RANG E1}	Range of typical programmable charge currents	Charger in CC-mode	5		80	mA
I _{CHARGE_RANG E1_stepsize}	Stepsize between programmable charge currents.	Charger in CC-mode		5		mA
I _{CHARGE_RANG E2}	Range of typical programmable charge currents	Charger in CC-mode	90		240	mA
I _{CHARGE_RANG E2_stepsize}	Stepsize between programmable charge currents.	Charger in CC-mode		10		mA
I _{CHARGE_RANG E3}	Range of typical programmable charge currents	Charger in CC-mode	260		560	mA
I _{CHARGE_RANG E3_stepsize}	Stepsize between programmable charge currents.	Charger in CC-mode		20		mA
I _{CHARGE_ACC}	Charge current accuracy of all typical values for T _{die} from 0 to 95C	Charger in CC-mode	-10		10	%
I _{PRECHARGE_R ANGE1}	Precharge range is normal range / 10	V _{bat} < precharge level	0.5		8	mA
I _{PRECHARGE_R ANGE1_stepsize}	Precharge current steps are normal steps / 10	V _{bat} < precharge level		0.5		mA
I _{PRECHARGE_R ANGE2}	Precharge range is normal range / 10	V _{bat} < precharge level	9		24	mA
I _{PRECHARGE_R ANGE2_stepsize}	Precharge current steps are normal steps / 10	V _{bat} < precharge level		1		mA
I _{PRECHARGE_R ANGE3}	Precharge range is normal range / 10	V _{bat} < precharge level	26		56	mA
I _{PRECHARGE_R ANGE3_stepsize}	Precharge current steps are normal steps / 10	V _{bat} < precharge level		2		mA
I _{PRECHARGE_A CC}	Charge current accuracy of all typical values for T _{die} from 0 to 95C	V _{bat} < precharge level	-15		22	%
I _{EOC_RATIO_RA NGE1}	Ratio [%] between EOC current and normal charge current	For normal Charge current range (no pre-charge)	4		8.5	%

Multi-Core Bluetooth 5.2 SoC Family with System PMU

Parameter	Description	Conditions	Min	Typ	Max	Unit
I _{EOC_RATIO_RA} NGE1_stepsize	Stepsize between Ratio settings of EOC current and normal charge current	For normal Charge current range (no pre-charge)		1.5		%
I _{EOC_RATIO_RA} NGE1_accuracy	Absolute accuracy of ratio between EOC current and normal charge current	For normal Charge current range (no pre-charge)	-2		2	%
I _{EOC_RATIO_RA} NGE2	Ratio [%] between EOC current and normal charge current	For normal Charge current range (no pre-charge)	10		16	%
I _{EOC_RATIO_RA} NGE2_stepsize	Stepsize between Ratio settings of EOC current and normal charge current	For normal Charge current range (no pre-charge)		2		%
I _{EOC_RATIO_RA} NGE2_accuracy	Absolute accuracy of ratio between EOC current and normal charge current	For normal Charge current range (no pre-charge)	-4		4	%
I _{EOC_RATIO_RA} NGE_multiplier	Multiplication factor [in %] of IEOCratio_RANGE1 and IEOCratio_RANGE2 Multiplication involves range, stepsize and accuracy	Range multiplier is set by bit "I_EOC_DOUBLE_RANGE"= 1		220		%
V _{CHARGE_RANGE} GE1	Range of typical programmable charge voltages	Forced charge current = 1 mA	2.8		3.8	V
V _{CHARGE_RANGE} GE1_step size	Stepsize between programmable charge voltages	Forced charge current = 1 mA		50		mV
V _{CHARGE_RANGE} GE2	Range of typical programmable charge voltages	Forced charge current = 1 mA	3.8		4.6	V
V _{CHARGE_RANGE} GE2_step size	Stepsize between programmable charge voltages	Forced charge current = 1 mA		20		mV
V _{CHARGE_RANGE} GE3	Range of typical programmable charge voltages	Forced charge current = 1 mA	4.6		4.8	V
V _{CHARGE_RANGE} GE3_step size	Stepsize between programmable charge voltages	Forced charge current = 1 mA		100		mV
V _{CHARGE_ACCURACY}	Charge voltage accuracy [%]	Forced charge current = 1 mA	-1.5		1.5	%
V _{REPLENISH_range}	Replenish voltage (where charging starts again)	Range is equal to whole "Vcharge" range	2.8		4.8	V
V _{REPLENISH_ACC}	Accuracy of programmable replenish voltages		-2		2	%
V _{PRECHARGE_range}	Precharge voltage threshold	Range is equal to whole "Vcharge" range	2.8		4.8	V
V _{PRE_CHG_ACC}	Accuracy of programmable precharge voltages		-2		2	%
V _{OVProtection_range}	Overvoltage Protection level	Range is equal to whole "Vcharge" range, added with 4.9V	2.8		4.9	V

Multi-Core Bluetooth 5.2 SoC Family with System PMU

Parameter	Description	Conditions	Min	Typ	Max	Unit
V _{OVP_ACC}	Accuracy of programmable OVP voltages		-2		2	%
N _{TCratio_0}	Voltage ratio between NTC-tap and ladder-top	Tab setting = 0; THOT comp. from 0 to 1	73.4	74.4	75.4	%
N _{TCratio_10}	Voltage ratio between NTC-tap and ladder-top	Tab setting = 10; THOT comp. from 0 to 1	63.7	64.7	65.7	%
N _{TCratio_20}	Voltage ratio between NTC-tap and ladder-top	Tab setting = 20; THOT comp. from 0 to 1	53.4	54.4	55.4	%
N _{TCratio_45}	Voltage ratio between NTC-tap and ladder-top	Tab setting = 45; THOT comp. from 0 to 1	30.3	31.3	32.3	%
N _{TCratio_55}	Voltage ratio between NTC-tap and ladder-top	Tab setting = 55; THOT comp. from 0 to 1	23.5	24.5	25.5	%
N _{TCratio_63}	Voltage ratio between NTC-tap and ladder-top	Tab setting = 63; THOT comp. from 0 to 1	19	20	21	%
T _{DIETEMP_PROT_RANGE}	Programmable range of the die-temperature protection.	All charge modes	80		130	°C
T _{DIETEMP_PROT_STEP}	Stepsize of the die-temperature protection selection.	All charge modes		10		°C
T _{DIETEMP_PROT_ACCURACY}	Accuracy of the die-temperature protection.	All charge modes	-13		13	°C
T _{SENSE_RANGE}	Temperature Sensor range	Readout via GPADC	-40		100	°C
T _{SENSE_ACC_uncalibrated}	Temperature Sensor accuracy over the whole temperature range without using calibration.	Minimum internal power dissipation Tx = (ADCx - 734)/2.3 where ADCx is 10 bit representation of GPADC	-24		24	°C
T _{SENSE_ACC_one_point_cal}	Temperature Sensor accuracy over the whole temperature range when using one-point calibration.	Equal internal power dissipation at calibration and measurement Tx = TCAL + (ADCx - ADCcal)/2.3 Where TCAL = temperature at calibration; ADCx = 10bit representation of Tx measurement; ADCcal = 10bit representation of calibration measurement	-6		6	°C
T _{SENSE_TC_ACC}	Sense temperature coefficient accuracy [%]	Temp.Coeff = 2.3 [LSB/°C] (typ)	-5		5	°C
t _{Charge_prot_PRECHARGE}	Precharge Time Protection [15 bits]	Timer runs in precharge mode	1		32767	s
t _{Charge_prot_CC-MODE}	CC-mode Charge Time Protection [15 bits]	Timer runs in CC-mode	1		32767	s

Parameter	Description	Conditions	Min	Typ	Max	Unit
t _{Charge_prot_CV-MODE}	CV-mode Charge Time Protection[15 bits]	Timer runs in CV-mode	1		32767	s
t _{Charge_prot_TO TAL_TIME}	Total Charge Time Protection[16 bits]	Timer runs in all active charge-modes	1		65535	s

5.19 Battery Check Characteristics

Table 48: BATCHECK - DC characteristics

Parameter	Description	Conditions	Min	Typ	Max	Unit
I _{ACC_BATCHECK K_1_2_mA}	current accuracy	Battery Check, Load current = 1mA or 2mA	-10		10	%
I _{ACC_BATCHECK K}	Current accuracy	Battery Check, Load current = 3, 4, 5, 6, 7 or 8 mA	-5		5	%

5.20 Digital I/O Characteristics

Table 49: GPIO - DC characteristics

Parameter	Description	Conditions	Min	Typ	Max	Unit
I _{IH}	HIGH level input current	V _I =V ₃₀ = 3.0 V	-10		10	μA
I _{IL}	LOW level input current	V _I =V _{SS} = 0 V	-10		10	μA
I _{IH_PD_3V0}	HIGH level input current	V _I =V ₃₀ = 3.0 V	60		180	μA
I _{IL_PU_3V0}	LOW level input current	V _I =V _{SS} = 0 V, V ₃₀ = 3.0 V	-180		-60	μA
I _{IL_PU_1V8}	LOW level input current	V _I =V _{SS} = 0 V, V _{18P} = 1.8 V	-110		-35	μA
V _{IH}	HIGH level input voltage	V ₁₂ = 1.2 V	0.7*V ₁₂			V
V _{IL}	LOW level input voltage	V ₁₂ = 1.2 V			0.3*V ₁₂	V
V _{OH_1V8}	HIGH level output voltage	I _o = 4.8 mA, V _{18P} = 1.8 V	0.8*V _{18P}			V
V _{OL_1V8}	LOW level output voltage	I _o = 4.8 mA, V _{18P} = 1.8 V			0.2*V _{18P}	V
V _{OH_3V0}	HIGH level output voltage	I _o = 4.8 mA, V ₃₀ = 3 V	0.8*V ₃₀			V
V _{OL_3V0}	LOW level output voltage	I _o = 4.8 mA, V ₃₀ = 3 V			0.2*V ₃₀	V
SR _R	Rising slew rate	C _L = 15 pF; I _L = 4.8 mA;	0.4		3.2	V/ns
SR _F	Falling slew rate	C _L = 15 pF; I _L = 4.8 mA;	0.4		3.3	V/ns
C _{IN}	Input capacitance			0.75		pF

Table 50: GPIO_LOWDRV - DC characteristics

Parameter	Description	Conditions	Min	Typ	Max	Unit
V _{OH_1V8_LOW DRV}	HIGH level output voltage, limited drive	I _o = 150 μ A, V _{18P} = 1.8 V, low drive enabled Note 2	0.8*V _{18P}			V
V _{OL_1V8_LOWRV}	LOW level output voltage, limited drive	I _o = 150 μ A, V _{18P} = 1.8 V, low drive enabled			0.2*V _{18P}	V

Note 2 Digital pad characteristics are equal to the standard GPIO pads unless overruled or added in this table

5.21 QSPI Characteristics

Table 51: QSPIF pad - DC characteristics

Parameter	Description	Conditions	Min	Typ	Max	Unit
V _{IH}	HIGH level input voltage	V _{18F} = 1.8 V	0.7*V _{18F}			V
V _{IL}	LOW level input voltage	V _{18F} = 1.8 V			0.3*V _{18F}	V
V _{OH_16mA}	HIGH level output voltage	I _o = 16 mA, V _{18F} = 1.8 V	0.8*V _{18F}			V
V _{OL_16mA}	LOW level output voltage	I _o = 16 mA, V _{18F} = 1.8 V			0.2*V _{18F}	V
I _{IH_PD}	HIGH level input current with pull-down	V _i = V _{18F} , V _{18F} = 1.8 V	25		75	μ A
C _{IN}	Input capacitance			0.87		pF

Table 52: QSPIR pad - DC characteristics

Parameter	Description	Conditions	Min	Typ	Max	Unit
V _{IH}	HIGH level input voltage	V _{18P} = 1.8 V	0.7*V _{18P}			V
V _{IL}	LOW level input voltage	V _{18P} = 1.8 V			0.3*V _{18P}	V
V _{OH_16mA}	HIGH level output voltage	I _o = 16 mA, V _{18P} = 1.8 V	0.8*V _{18P}			V
V _{OL_16mA}	LOW level output voltage	I _o = 16 mA, V _{18P} = 1.8 V			0.2*V _{18P}	V
I _{IH}	HIGH level input current	V _i =V _{18P} = 1.8 V	-10		10	μ A
I _{IH_PD}	HIGH level input current with pull-down	V _i =V _{18P} = 1.8 V	25		75	μ A
I _{IL}	LOW level input current	V _i =V _{SS} , V _{18P} = 1.8 V	-10		10	μ A
I _{IL_PU}	LOW level input current with pull-up	V _i =V _{SS} , V _{18P} = 1.8 V	-75		-25	μ A
C _{IN}	Input capacitance			0.87		pF

5.22 LED Characteristics

Table 53: LED_DRIVER - DC characteristics

Parameter	Description	Conditions	Min	Typ	Max	Unit
I _{O_MAX_LED1}	Maximum sink current	V _{LED1} = 200 mV, 100% duty cycle	19		21	mA
I _{O_MAX_LED2}	Maximum sink current	V _{LED2} = 200 mV, 100% duty cycle	19		21	mA
I _{MATCH_LED}	Current matching	Relative to average LED sink current	-2		2	%
I _{ACC_LED1}	Current accuracy	PWM accuracy at 10% duty cycle and above relative to I _{O_MAX_LED} (100% duty cycle)	-2		2	%
I _{ACC_LED2}	Current accuracy	PWM accuracy at 10% duty cycle and above relative to I _{O_MAX_LED} (100% duty cycle)	-2		2	%
I _{OFF_LED1}	Off-state current	Driver disabled	-1		10	μA
I _{OFF_LED2}	Off-state current	Driver disabled	-1		10	μA

Table 54: LED_DRIVER - AC characteristics

Parameter	Description	Conditions	Min	Typ	Max	Unit
f _{PWM_LED}	PWM frequency		125		32000	Hz

5.23 LRA Characteristics

Table 55: LRA - Recommended operating conditions

Parameter	Description	Conditions	Min	Typ	Max	Unit
I _{L_MAX}	Maximum load current			250		mA

Table 56: LRA - DC characteristics

Parameter	Description	Conditions	Min	Typ	Max	Unit
I _{ACC_calib}	Current accuracy				1.5	%
R _{ON_HSN}	On resistance				5	Ω
R _{ON_HSP}	On resistance				5	Ω
R _{ON_LSN}	On resistance				5	Ω
R _{ON_LSP}	On resistance				5	Ω
R _{S_LSN}	Series resistance				1.5	Ω
R _{S_LSP}	Series resistance				1.5	Ω
V _{REF_OCPN}	Reference voltage	SCP_LS_TRIM_N = 5	0.35	0.5	0.7	V
V _{REF_OCPP}	Reference voltage	SCP_LS_TRIM_P = 5	0.35	0.5	0.7	V

Table 57: LRA - AC characteristics

Parameter	Description	Conditions	Min	Typ	Max	Unit
f _{PWM_OUT}	PWM frequency of H-bridge output			250		kHz

5.24 USB Characteristics

Table 58: GPIO_USB - DC characteristics

Parameter	Description	Conditions	Min	Typ	Max	Unit
I _{IH}	HIGH level input current Note 2	V _I =V ₃₀ = 3.0 V	-20		20	μA
I _{IL}	LOW level input current	V _I =V _{SS} = 0 V	-20		20	μA

Note 2 Digital pad characteristics are equal to the standard GPIO pads unless overruled or added in this table

5.25 USB Charger Detection Characteristics

Table 59: USB_CHRG_DET - DC characteristics

Parameter	Description	Conditions	Min	Typ	Max	Unit
V _{IH_CHG_DET}	HIGH level input voltage	USB_CHARGER_CTRL_REG [VDP_SRC_ON] = 1	0.4			V
V _{IL_CHG_DET}	LOW level input voltage	USB_CHARGER_CTRL_REG [VDP_SRC_ON] = 1;			0.25	V
V _{IH_DCP_DET}	HIGH level input voltage	USB_CHARGER_CTRL_REG [VDM_SRC_ON] = 1; V ₃₀ = 3.3 V	0.4			V
V _{IL_DCP_DET}	LOW level input voltage	USB_CHARGER_CTRL_REG [VDM_SRC_ON] = 1; V ₃₀ = 3.3 V			0.25	V
V _{IH_DM_VAL}	HIGH level input voltage	V ₃₀ = 3.3 V	1.5			V
V _{IL_DM_VAL}	LOW level input voltage	V ₃₀ = 3.3 V			0.8	V
V _{IH_DP_VAL}	HIGH level input voltage	V ₃₀ = 3.3 V	1.5			V
V _{IL_DP_VAL}	LOW level input voltage	V ₃₀ = 3.3 V			0.8	V
V _{IH_DM_VAL2}	HIGH level input voltage	V ₃₀ = 3.3 V	2.5			V
V _{IL_DM_VAL2}	LOW level input voltage	V ₃₀ = 3.3 V			2.3	V
V _{IH_DP_VAL2}	HIGH level input voltage	V ₃₀ = 3.3 V	2.5			V
V _{IL_DP_VAL2}	LOW level input voltage	V ₃₀ = 3.3 V			2.3	V
V _{O_DM_SRC}	Output voltage	V ₃₀ = 3.3V	0.5		0.7	V
V _{O_DP_SRC}	Output voltage	V ₃₀ = 3.3V	0.5		0.7	V
I _{DM_SINK}	D- sink current	V ₃₀ = 3.3 V	25		175	μA
I _{DP_SINK}	D+ sink current	V ₃₀ = 3.3 V	25		175	μA

Parameter	Description	Conditions	Min	Typ	Max	Unit
I _{DP_SRC}	D+ source current	V ₃₀ = 3.3 V	5		13	μA
R _{DM_DWN}	D- resistance to ground	USB_CHARGER_CTRL_REG [IDP_SRC_ON] = 1; V ₃₀ = 3.3 V	14.25		24.8	kΩ

5.26 Radio Characteristics

Table 60: Radio BLE 1M - Recommended operating conditions

Parameter	Description	Conditions	Min	Typ	Max	Unit
f _{OPER}	Operating frequency		2400		2483.5	MHz
N _{CH}	Number of channels			40		1
f _{CH}	Channel frequency	K = 0 to 39		2402+K*2		MHz

Table 61: Radio BLE 1M - DC characteristics

Parameter	Description	Conditions	Min	Typ	Max	Unit
I _{BAT_RF_RX}	RX only battery supply current	Radio receiver and synthesizer active; ideal DC-DC converter; T _A = 25 °C Note 2		1.8		mA
I _{BAT_RF_TX_+6dBm}	TX only battery supply current	Radio transmitter and synthesizer active; power setting = 15; ideal DC-DC converter; T _A = 25 °C Note 2		5.2		mA
I _{BAT_RF_TX_0dBm}	TX only battery supply current	Radio transmitter and synthesizer active; power setting = 8; ideal DC-DC converter; T _A = 25 °C Note 2		3		mA
I _{BAT_RF_TX_-3dBm}	TX only battery supply current	Radio transmitter and synthesizer active; power setting = 5; ideal DC-DC converter; T _A = 25 °C Note 2		2.2		mA
I _{BAT_RF_TX_-6dBm}	TX only battery supply current	Radio transmitter and synthesizer active; power setting = 4; ideal DC-DC converter; T _A = 25 °C Note 2		1.9		mA
I _{BAT_RF_TX_-12dBm}	TX only battery supply current	Radio transmitter and synthesizer active; power setting = 2; ideal DC-DC converter; T _A = 25 °C Note 2		1.4		mA

Multi-Core Bluetooth 5.2 SoC Family with System PMU

Parameter	Description	Conditions	Min	Typ	Max	Unit
$I_{BAT_RF_TX_18dBm}$	TX only battery supply current	Radio transmitter and synthesizer active; power setting = 1; ideal DC-DC converter; $T_A = 25\text{ }^\circ\text{C}$ Note 2		1.1		mA

Note 2 The DC-DC converter efficiency is assumed to be 100 % to enable benchmarking of the radio currents at battery supply domain.

Table 62: Radio BLE 1M - AC characteristics

Parameter	Description	Conditions	Min	Typ	Max	Unit
P_{SENS_CLEAN}	Sensitivity level	Dirty Transmitter disabled; DC-DC converter disabled; PER = 30.8 %; Note 2		-97		dBm
P_{SENS}	Sensitivity level	Dirty Transmitter enabled; DC-DC converter disabled; PER = 30.8 %; Note 2		-96.5		dBm
$P_{SENS_EPKT_CLEAN}$	Sensitivity level	Dirty Transmitter disabled; DC-DC converter disabled; Extended packet size (255 octets) Note 2		-95.5		dBm
P_{SENS_EPKT}	Sensitivity level	Dirty Transmitter enabled; DC-DC converter disabled; Extended packet size (255 octets)		-94.5		dBm
P_{INT_IMD}	Intermodulation distortion interferer power level	Interferer level @ f_1, f_2 with $2*f_1 - f_2 = f_0, f_1 - f_2 = n\text{ MHz}$ and $n = 3, 4, 5$; $P_{WANTED} = -64\text{ dBm @ } f_0$; PER = 30.8 %; Note 2		-28		dBm
CIR_0	Carrier to interferer ratio	$n = 0$; interferer @ $f_1 = f_0 + n*1\text{ MHz}$; Note 2		7		dB
CIR_{P1}	Carrier to interferer ratio	$n = +1$; interferer @ $f_1 = f_0 + n*1\text{ MHz}$; Note 2		-3		dB
CIR_{M1}	Carrier to interferer ratio	$n = -1$; interferer @ $f_1 = f_0 + n*1\text{ MHz}$; Note 2		-5		dB
CIR_{P2}	Carrier to interferer ratio	$n = +2$ (image frequency); interferer @ $f_1 = f_0 + n*1\text{ MHz}$; Note 2		-30		dB

Multi-Core Bluetooth 5.2 SoC Family with System PMU

Parameter	Description	Conditions	Min	Typ	Max	Unit
CIR _{M2}	Carrier to interferer ratio	n = -2; interferer @ f ₁ = f ₀ + n*1 MHz; Note 2		-37		dB
CIR _{P3}	Carrier to interferer ratio	n = +3 (image frequency + 1 MHz); interferer @ f ₁ = f ₀ + n*1 MHz; Note 2		-42		dB
CIR _{M3}	Carrier to interferer ratio	n = -3; interferer @ f ₁ = f ₀ + n*1 MHz; Note 2		-47		dB
CIR _{P4}	Carrier to interferer ratio	n = +4; interferer @ f ₁ = f ₀ + n*1 MHz; Note 2		-48		dB
CIR _{M4}	Carrier to interferer ratio	n = -4; interferer @ f ₁ = f ₀ + n*1 MHz; Note 2		-51		dB
CIR ₅	Carrier to interferer ratio	n ≥ 5; interferer @ f ₁ = f ₀ + n*1 MHz; Note 2		-52		dB
P _{BL_I}	Blocker power level	30 MHz ≤ f _{BL} ≤ 2000 MHz; P _{WANTED} = -67 dBm; Note 2		5		dBm
P _{BL_II}	Blocker power level	2003 MHz ≤ f _{BL} ≤ 2399 MHz; P _{WANTED} = -67 dBm; Note 3		0		dBm
P _{BL_III}	Blocker power level	2484 MHz ≤ f _{BL} ≤ 2997 MHz; P _{WANTED} = -67 dBm; Note 3		0		dBm
P _{BL_IV}	Blocker power level	3000 MHz ≤ f _{BL} ≤ 12.75 GHz; P _{WANTED} = -67 dBm; Note 2		5		dBm
L _{ACC_RSSI}	RSSI level accuracy	Tolerance at 5 % to 95 % confidence interval of P _{RF} (in -90 dBm to -20 dBm range); burst mode, 1500 packets;		2		dB
L _{RES_RSSI}	RSSI level resolution	Gradient of monotonous range (-90 dBm to -20 dBm); burst mode, 1500 packets;		0.5		dB/LSB
ACP _{2M}	Adjacent channel power level	Output power set to 6dBm; f _{OF3} = 2 MHz; Note 2		-51		dBm
ACP _{3M}	Adjacent channel power level	Output power set to 6dBm; f _{OF3} ≥ 3 MHz; Note 2		-56		dBm

Parameter	Description	Conditions	Min	Typ	Max	Unit
P _{O_15}	Output power level	Power set to 6 dBm		6		dBm
P _{O_14}	Output power level	Power set to 5 dBm		5		dBm
P _{O_13}	Output power level	Power set to 4.5 dBm		4.5		dBm
P _{O_12}	Output power level	Power set to 4 dBm		4		dBm
P _{O_11}	Output power level	Power set to 3 dBm		3		dBm
P _{O_10}	Output power level	Power set to 2 dBm		2		dBm
P _{O_09}	Output power level	Power set to 1.5 dBm		1.5		dBm
P _{O_08}	Output power level	Power set to 0 dBm		0.5		dBm
P _{O_07}	Output power level	Power set to -1 dBm		-1		dBm
P _{O_06}	Output power level	Power set to -2 dBm		-2		dBm
P _{O_05}	Output power level	Power set to -3 dBm		-3.5		dBm
P _{O_04}	Output power level	Power set to -6 dBm		-5.5		dBm
P _{O_03}	Output power level	Power set to -8 dBm		-8		dBm
P _{O_02}	Output power level	Power set to -12 dBm		-11.5		dBm
P _{O_01}	Output power level	Power set to -18 dBm		-17.5		dBm
P _{O_01A1}	Output power level	Power set to -22 dBm		-22		dBm
P _{O_01A2}	Output power level	Power set to -26 dBm		-26		dBm
P _{O_ULP}	Output power level	Power set to -50 dBm		-51		dBm

Note 1 Hidden result number reset field ListNum

Note 2 Measured according to Bluetooth® Low Energy Test Specification RF-PHY.TS

Note 3 Measured according to Bluetooth® Low Energy Test Specification RF-PHY.TS. Frequencies close to the ISM band can show slightly worse performance

Table 63: Radio BLE 2M - Recommended operating conditions

Parameter	Description	Conditions	Min	Typ	Max	Unit
f _{OPER}	Operating frequency		2400		2483.5	MHz
N _{CH}	Number of channels			40		1
f _{CH}	Channel frequency	K = 0 to 39		2402+K*2		MHz

Table 64: Radio BLE 2M - DC characteristics

Parameter	Description	Conditions	Min	Typ	Max	Unit
I _{BAT_RF_RX}	RX only battery supply current	Radio receiver and synthesizer active; ideal DC-DC converter; T _A = 25 °C Note 2		1.9		mA

Parameter	Description	Conditions	Min	Typ	Max	Unit
$I_{BAT_RF_TX_+6dBm}$	TX only battery supply current	Radio transmitter and synthesizer active; power setting = 15; ideal DC-DC converter; $T_A = 25\text{ }^\circ\text{C}$ Note 2		5.2		mA
$I_{BAT_RF_TX_0dBm}$	TX only battery supply current	Radio transmitter and synthesizer active; power setting = 8; ideal DC-DC converter; $T_A = 25\text{ }^\circ\text{C}$ Note 2		3		mA
$I_{BAT_RF_TX_3dBm}$	TX only battery supply current	Radio transmitter and synthesizer active; power setting = 5; ideal DC-DC converter; $T_A = 25\text{ }^\circ\text{C}$ Note 2		2.2		mA
$I_{BAT_RF_TX_6dBm}$	TX only battery supply current	Radio transmitter and synthesizer active; power setting = 4; ideal DC-DC converter; $T_A = 25\text{ }^\circ\text{C}$ Note 2		1.9		mA
$I_{BAT_RF_TX_12dBm}$	TX only battery supply current	Radio transmitter and synthesizer active; power setting = 2; ideal DC-DC converter; $T_A = 25\text{ }^\circ\text{C}$ Note 2		1.4		mA
$I_{BAT_RF_TX_18dBm}$	TX only battery supply current	Radio transmitter and synthesizer active; power setting = 1; ideal DC-DC converter; $T_A = 25\text{ }^\circ\text{C}$ Note 2		1.1		mA

Note 2 The DC-DC converter efficiency is assumed to be 100 % to enable benchmarking of the radio currents at battery supply domain.

Table 65: Radio BLE 2M - AC characteristics

Parameter	Description	Conditions	Min	Typ	Max	Unit
P_{SENS_CLEAN}	Sensitivity level	Dirty Transmitter disabled; DC-DC converter disabled; PER = 30.8 %; Note 2		-94.5		dBm
P_{SENS}	Sensitivity level	Dirty Transmitter enabled; DC-DC converter disabled; PER = 30.8 %; Note 2		-94		dBm
$P_{SENS_EPKT_CLEAN}$	Sensitivity level	Dirty Transmitter disabled; DC-DC converter disabled; Extended packet size (255 octets) Note 2		-93		dBm

Multi-Core Bluetooth 5.2 SoC Family with System PMU

Parameter	Description	Conditions	Min	Typ	Max	Unit
P _{SENS_EPKT}	Sensitivity level	Dirty Transmitter enabled; DC-DC converter disabled; Extended packet size (255 octets)		-92.5		dBm
P _{INT_IMD}	Intermodulation distortion interferer power level	Interferer level @ f_1, f_2 with $2*f_1 - f_2 = f_0$, $ f_1 - f_2 = n \times 2\text{MHz}$ and $n = 3, 4, 5$; P _{WANTED} = -64 dBm @ f_0 ; PER = 30.8 %; Note 2		-27		dBm
CIR ₀	Carrier to interferer ratio	$n = 0$; interferer @ $f_1 = f_0 + n*2\text{MHz}$; Note 2		6		dB
CIR _{P1}	Carrier to interferer ratio	$n = +1$; interferer @ $f_1 = f_0 + n*2\text{MHz}$; Note 2		-4		dB
CIR _{M1}	Carrier to interferer ratio	$n = -1$; interferer @ $f_1 = f_0 + n*2\text{MHz}$; Note 2		-4		dB
CIR _{P2}	Carrier to interferer ratio	$n = +2$ (image frequency); interferer @ $f_1 = f_0 + n*2\text{MHz}$; Note 2		-31		dB
CIR _{M2}	Carrier to interferer ratio	$n = -2$; interferer @ $f_1 = f_0 + n*2\text{MHz}$; Note 2		-36		dB
CIR _{P3}	Carrier to interferer ratio	$n = +3$ (image frequency + 1 MHz); interferer @ $f_1 = f_0 + n*2\text{MHz}$; Note 2		-41		dB
CIR _{M3}	Carrier to interferer ratio	$n = -3$; interferer @ $f_1 = f_0 + n*2\text{MHz}$; Note 2		-47		dB
CIR _{P4}	Carrier to interferer ratio	$n = +4$; interferer @ $f_1 = f_0 + n*2\text{MHz}$; Note 2		-41		dB
CIR _{M4}	Carrier to interferer ratio	$n = -4$; interferer @ $f_1 = f_0 + n*2\text{MHz}$; Note 2		-47		dB
CIR ₅	Carrier to interferer ratio	$ n \geq 5$; interferer @ $f_1 = f_0 + n*2\text{MHz}$; Note 2		-53		dB
P _{BL_I}	Blocker power level	$30\text{MHz} \leq f_{BL} \leq 2000\text{MHz}$; P _{WANTED} = -67 dBm; Note 2		5		dBm

Multi-Core Bluetooth 5.2 SoC Family with System PMU

Parameter	Description	Conditions	Min	Typ	Max	Unit
P _{BL_II}	Blocker power level	2003 MHz ≤ f _{BL} ≤ 2399 MHz; P _{WANTED} = -67 dBm; Note 3		0		dBm
P _{BL_III}	Blocker power level	2484 MHz ≤ f _{BL} ≤ 2997 MHz; P _{WANTED} = -67 dBm; Note 3		0		dBm
P _{BL_IV}	Blocker power level	3000 MHz ≤ f _{BL} ≤ 12.75 GHz; P _{WANTED} = -67 dBm; Note 2		5		dBm
L _{ACC_RSSI}	RSSI level accuracy	Tolerance at 5 % to 95 % confidence interval of PRF (in -90 dBm to -20 dBm range); burst mode, 1500 packets;		2		dB
L _{RES_RSSI}	RSSI level resolution	Gradient of monotonous range (-90 dBm to -20 dBm); burst mode, 1500 packets;		0.5		dB/LSB
ACP _{4M}	Adjacent channel power level	Output power set to 6dBm; f _{ofs} = 4 MHz; Note 2		-57		dBm
ACP _{5M}	Adjacent channel power level	Output power set to 6dBm; f _{ofs} = 5 MHz; Note 2		-61		dBm
ACP _{6M}	Adjacent channel power level	Output power set to 6dBm; f _{ofs} ≥ 6 MHz; Note 2		-60		dBm
P _{O_15}	Output power level	Power set to 6 dBm		6		dBm
P _{O_14}	Output power level	Power set to 5 dBm		5		dBm
P _{O_13}	Output power level	Power set to 4.5 dBm		4.5		dBm
P _{O_12}	Output power level	Power set to 4 dBm		4		dBm
P _{O_11}	Output power level	Power set to 3 dBm		3		dBm
P _{O_10}	Output power level	Power set to 2 dBm		2		dBm
P _{O_09}	Output power level	Power set to 1.5 dBm		1.5		dBm
P _{O_08}	Output power level	Power set to 0 dBm		0.5		dBm
P _{O_07}	Output power level	Power set to -1 dBm		-1		dBm
P _{O_06}	Output power level	Power set to -2 dBm		-2		dBm
P _{O_05}	Output power level	Power set to -3 dBm		-3.5		dBm
P _{O_04}	Output power level	Power set to -6 dBm		-5.5		dBm
P _{O_03}	Output power level	Power set to -8 dBm		-8		dBm
P _{O_02}	Output power level	Power set to -12 dBm		-11.5		dBm

Multi-Core Bluetooth 5.2 SoC Family with System PMU

Parameter	Description	Conditions	Min	Typ	Max	Unit
P _{O_01}	Output power level	Power set to -18 dBm		-17.5		dBm
P _{O_01A1}	Output power level	Power set to -22 dBm		-22		dBm
P _{O_01A2}	Output power level	Power set to -26 dBm		-26		dBm
P _{O_ULP}	Output power level	Power set to -50 dBm		-51		dBm

Note 2 Measured according to Bluetooth® Low Energy Test Specification RF-PHY.TS

Note 3 Measured according to Bluetooth® Low Energy Test Specification RF-PHY.TS. Frequencies close to the ISM band can show slightly worse performance

6. System Overview

6.1 Internal Blocks

The DA1469x family contains the following blocks:

Arm® Cortex®-M33 CPU: This processor provides 1.5 dMIPS/MHz and is used for implementing the higher layers of the Bluetooth® Low Energy protocol (Host). It is also used for the application requirements. This includes controlling the system's power scheme for up to 144 dMIPs, if required. It has a powerful cache controller with configurable associativity, cache line size and RAM size. The CPU executes code from FLASH using a 16 kB cache controller. Code in the FLASH might be encrypted; so, decryption will happen while in progress without extra wait states.

BLE 5.x MAC: This is a Configurable MAC (CMAC) based on the Cortex-M0+ CPU and hardware accelerators implementing all timing critical tasks of the Bluetooth® LE Controller stack.

ROM: This is a 128 kB ROM containing the booter code as well as the routines for implementing authentication of the FLASH image (using Elliptic Curves).

OTP: This is a 4 kB One Time Programmable memory array which contains the symmetric keys for the FLASH image decryption, the symmetric keys for the application AES operations, and the public keys for the authentication of the FLASH image during boot. It also contains trim values programmed during production testing. It allows for a small secondary bootloader (if required) by the application.

Data RAM: Up to 512 kB Data RAM (DataRAM) which is shared between all masters of the system. It is used for storing code and data of the Bluetooth® LE MAC, the Sensor Node Controller and application data (Cortex-M33). It comprises RAM cells of 64 kB each, all with content retaining as well as complete power switch off capability.

QSPI Controllers: There are 2 QSPI controllers. One dedicated to FLASH communication (supporting XiP), the other to PSRAM/FLASH communication used to extend the embedded RAM or to store data into non-volatile while executing code. The dedicated FLASH controller supports decrypting on-the-fly while reading from the FLASH, using a dedicated AES-256-bit decryption unit, without increasing the fetch number of clock cycles.

LCD Controller: This controller supports a number of parallel and serial LCD interfaces. It incorporates a DMA that allows for autonomous operation without CPU intervention.

Cryptography Controllers: They consist of an AES 256 bits block and a HASH controller implementing SHA-1, SHA-2. This accelerates any application security requirements. A True Random Number Generator (TRNG) is also provided, that enables secure key generation.

Motor Controller: This is an autonomous gear box driver. It can be configured to control a number of different coil-based lavet motors: while the rest of the system is in sleep mode. It can be used for efficiently implementing smart watches with analog hands.

UART, UART2 and UART3: Asynchronous serial interfaces. UART2 implements hardware flow control while UART3 is amended with ISO7816 functionality for connecting to a secure element. All UARTs are equipped with a FIFO of 16 bytes depth supporting. UART supports up to 1 Mbps while UART2 and UART3 can reach up to 3 Mbps.

SPI and SPI2: These are the serial peripheral interfaces with master/slave capability. They have an 8-byte/4-byte RX/TX FIFO respectively.

I2C and I2C2: These are Master/Slave I2C interfaces used for sensors and/or host MCU communication. Each controller includes a 32 locations deep FIFO (8-bits Rx, 10-bits Tx). They can both achieve up to 2.9 Mbps with 32-MHz system clock.

Audio blocks: This part enables audio streaming by means of a Pulse Density Modulation (PDM), a Sample Rate Converter (SRC) and a Pulse Code Modulation (PCM) interface. It can support up to two digital microphones or two digital loudspeakers using the PDM interface or connect an external CoDec at the PCM/I2S interface.

General Purpose (GP) ADC: This is a 10-bit analog to digital converter with 8 external input channels and averaging circuitry, which increase the effective number of bits (ENOB) to 11 using oversampling up to 64 times.

Sigma-Delta (SD) ADC: This is a 14-bit analog to digital converter with 8 external input channels and the possibility of an external voltage reference.

Radio Transceiver: This block implements the digital and analog PHY of the Bluetooth® Low Energy protocol at 2.4 GHz.

General Purpose Timers: Four general purpose timers of 24-bit width each are available for the user, two of them in the system power domain and two in their own power domain. They provide several features like PWM generation, two capture channels that save a snapshot of the timer, up/down counting with free-running mode, selectable clock source and one-shot pulse generation with configurable width.

Real Time Clock: This is a hardware controller that supports the complete time of day clock: 12/24 hours, minutes, seconds, milliseconds, and hundredths of milliseconds. It comprises a configurable alarm function and can be programmed to generate an interrupt on any event like a rollover of month, day, hour, minute, second or hundredths of milliseconds.

Watchdog Timers: The system comprises two watchdog timers, 13-bit wide each. One for CMAC SW monitoring (CMAC Wdog) and another for the System CPU (System Wdog). The System watchdog is constantly counting down, automatically started right after POWERUP, it is powered by the always on domain and will generate an NMI and a HW Reset when 0 and -16 is reached respectively. Its maximum counting time is 84 seconds or 3 minutes depending on the clock used (RC32K or RCX). The CMAC Watchdog resides in the Radio power domain and will generate an interrupt to the CMAC CPU when 0 is reached. It will also generate a HW reset if -16 is reached. Both watchdogs are automatically frozen when either of the two CPUs is in debug mode.

Wake-up Controller: This is a controller for capturing external events that can be used as a wake-up trigger on any of the GPIO ports with programmable polarity. It comprises a single debouncing structure for generating a wake-up interrupt upon a button press.

LRA/ERM Driver: This block implements the haptic driver for external linear resonant actuators (LRA) or eccentric rotating mass (ERM) motors. It comprises an H-Bridge and automatically adapts to the resonant frequency of the haptic feedback actuator. It has a configurable supply current that can be used to set the force of the haptic feedback.

White LED Drivers: There are two *white* LED drivers that can sink up to 20 mA current. Their intensity is controlled by a dedicated configurable PWM signal. It provides programmability regarding the amount of sinking current while sustaining an accuracy of +/- 5 %.

USB FS Device: This is a 12 Mbit/s USB device controller, which is mainly used for software upgrades. It is also used for recharging the system's battery. It supports 7 endpoints.

DMA Engine: This is a general-purpose DMA engine with 8 channels that can be multiplexed to support data transfers between memory resources but also between memory and peripherals in single or burst modes (where applicable). It is also used when secure features are enabled to perform key transfers from OTP to registers without CPU having access.

Sensor Node Controller: This is a seven instructions state machine that acts as a smart DMA controller and can be programmed to manipulate all serial interfaces. It is primarily designed to program, serve, and fetch data from external sensors to RAM, where it has a direct connection to improve speed.

6.2 Digital Power Domains

The DA1469x supports several digital power domains that can be turned ON and OFF independently from one another.

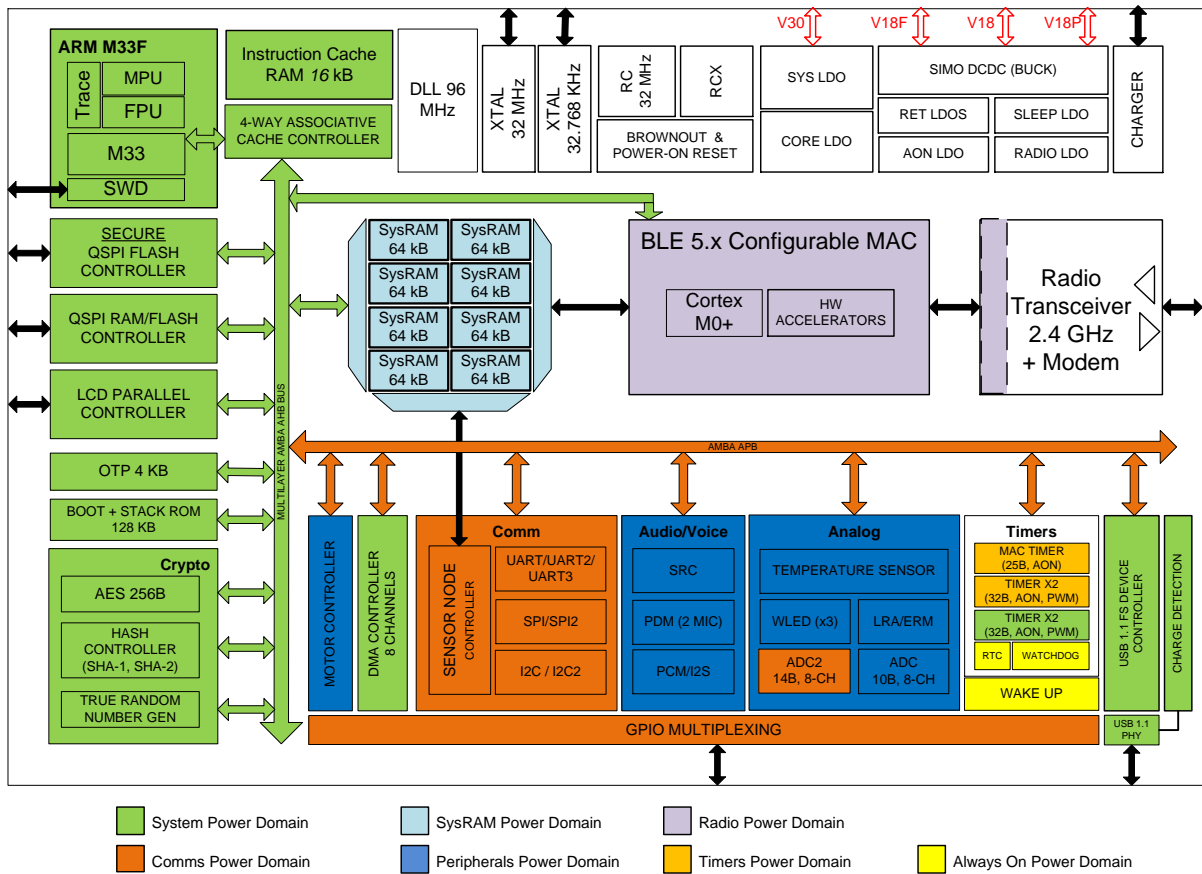

Figure 7. Digital power domains and blocks mapping

Description and domain names used throughout this document is shown in Table 66.

Table 66: Power domains description

Domain name	Description
PD_SYS	System Power Domain. It comprises the Cortex-M33 CPU, the QSPI controllers, the LDC controller, OTP, ROM, USB, DMA, Crypto blocks, and two general purpose Timers. It also contains the AHB multilayer bus.
PD_AON	Always-On Power Domain. It comprises the wake-up controller, the system watchdog and power management as well as clock generation circuitry. It also contains the RTC.
PD_COM	Communications Power Domain. It comprises the Sensor Node Controller, all serial interfaces and SD ADC. It also supplies the GPIO multiplexing.
PD_MEM	Memory Power Domain. It comprises the memory controller, the DCDC digital FSM and the RAM cells.
PD_TMR	Timer Power Domain. It comprises the MAC timer, two general purpose Timers, and the XTAL32M digital state machine.
PD_PER	Peripherals Power Domain. It comprises the Audio blocks, the Motor Controller, the GP ADC, the WLEDs and LRA and the on-chip temperature sensors.
PD_RAD	Radio Power Domain. It comprises the CMAC and the digital PHY of the Radio.

6.3 Hardware FSM (POWERUP, WAKEUP, GOTO Sleep)

6.3.1 Hardware FSM

The hardware FSM responsible for the POWERUP, WAKEUP and GOTO sleep process of the system is presented in the following flow chart.

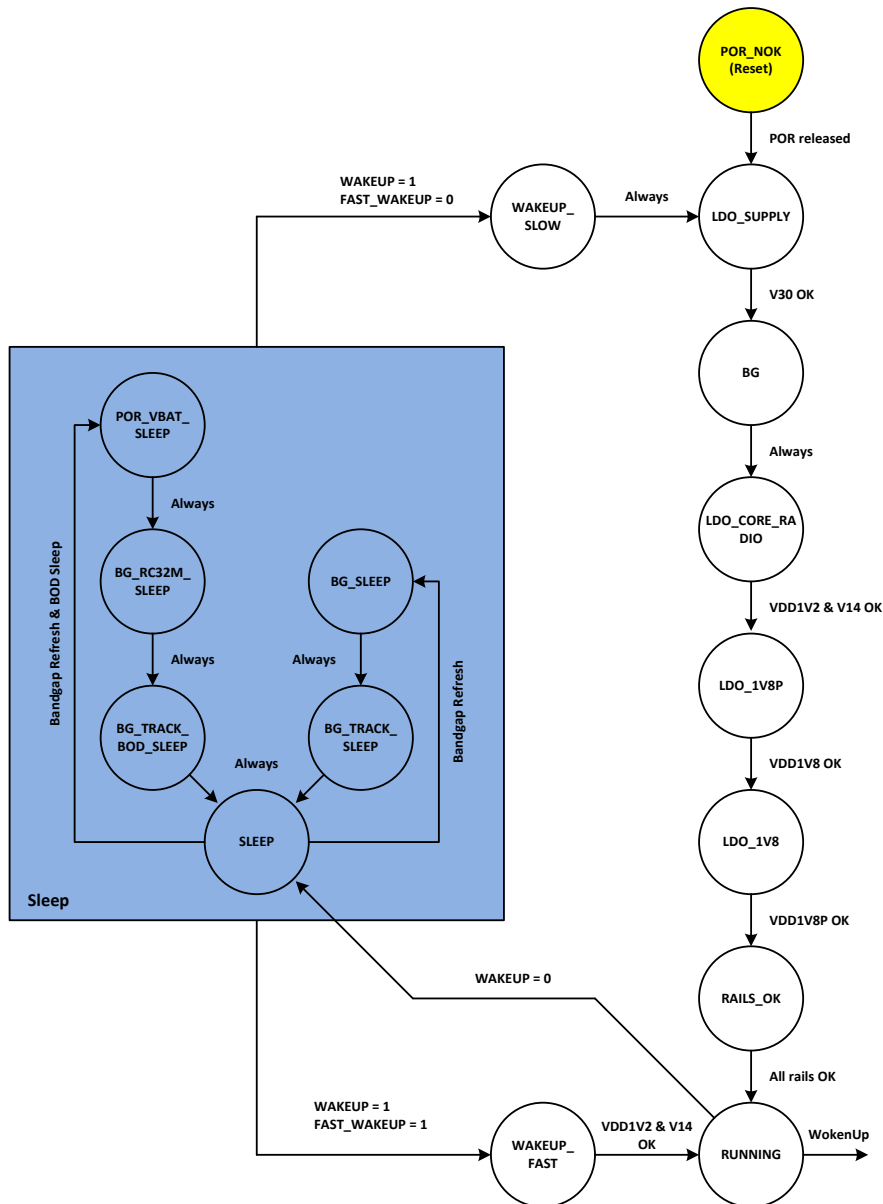

Figure 8. POWERUP, WAKEUP, GOTO Sleep hardware FSM

The WAKEUP signal indicates that the hardware FSM has finished, and the digital power domains are initialized. This signal can be monitored at register bit field SYS_STAT_REG[POWER_IS_UP].

6.3.2 POWERUP

After POR is released, the FSM enters state LDO_SUPPLY where the following actions are taken

- The COLD_BOOT bit is asserted indicating that the system recovers from a POR (previous state must be POR_NOK)
- The LDO_VBAT is enabled. The LDO requires some time to settle so the voltage is stable at its output. This time is always <math><300\ \mu\text{s}</math>. A timeout mechanism is set for 400 μs

The next state (BG) triggers the following operations:

- Bandgap is enabled

The latency of this state is always one 32 kHz clock cycle.

In the next state (LDO_CORE_RADIO), the

- LDO_CORE is enabled depending on the programmed register bit¹

¹ These bits can be programmed in the POWER_CTRL_REG

- LDO_RADIO is enabled depending on the programmed register bit

It should never exceed 150 μs, so a timeout is set for this value. When this state is done, both the LDO_CORE is regulating supplying the core with 0.9 V and the LDO_RADIO with 1.4 V the V14 rail.

The next 2 states enable the V18P and V18 (provided that the respective bits are enabled). A timeout of 300 μs is set for both power rails.

A final state of one clock cycle is used for checking if all Rails are powered (RAILS_OK) before releasing the system to RUNNING state and assert the WOKENUP signal (which can be mapped on a GPIO or monitored at a register bit), allowing software to start running.

The following timing diagram summarizes the aforementioned description.

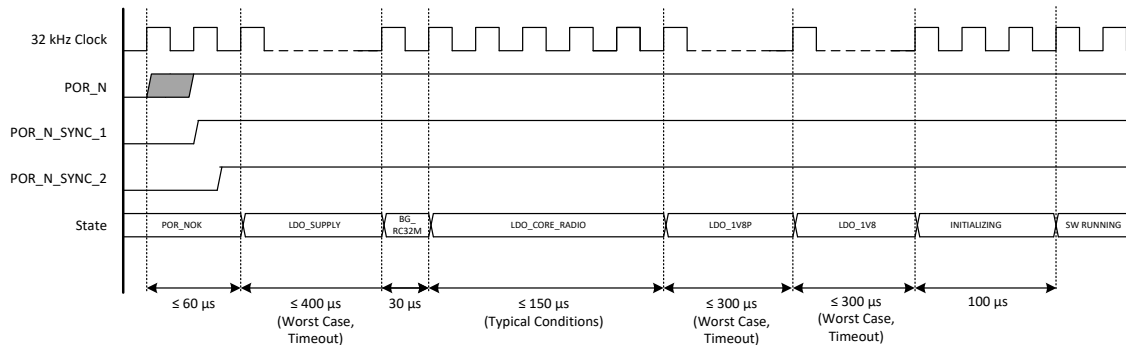

Figure 9. POWERUP timing diagram

6.3.3 WAKEUP Options

The system supports three different WAKEUP options. It can be configured which one to select depending on the application requirements and constraints. Table 67 summarizes the WAKEUP modes characteristics.

Table 67: Wake-up modes

Wake-up mode	Latency	Recommended	Description	Constraints
Slow	600 μs	If system sleeps for a long time (>8 sec)	All LDOs of the Power Management are powered sequentially. Software is released to run after all LDO OK signals are evaluated.	None
Fast	300 μs	If system sleeps for <8 sec	All LDOs of the Power Management are powered simultaneously. Software is released to run after Core and Radio LDO OK signals are evaluated.	None
Ultra-Fast	~100 μs	If system sleeps for <100 ms	All LDOs of the Power Management are powered simultaneously. Software is release 2 low power clocks after wake-up trigger without evaluating any LDO ok signal.	No heavy load (>0.5 mA) should be applied for the first 100 μs. The VDD_SLEEP_LEVEL voltage must be 0.9 V.

6.3.3.1 Slow WAKEUP

The slow WAKEUP is following the states of the cold boot. It, however, de-asserts the COLD_BOOT flag. Figure 10 shows the timing diagram of the slow WAKEUP.

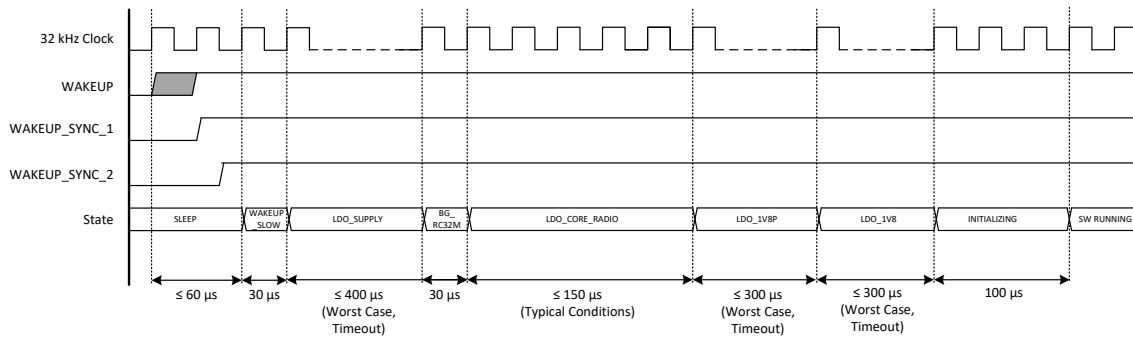

Figure 10. Slow wake-up timing

A typical latency of the slow wake up, is in the range of 1 ms, while maximum (assuming time outs) can reach 1.5 ms. This WAKEUP mode is recommended in cases where the device is in Sleep mode for over four seconds.

6.3.3.2 Fast Wake-up

Enabling Fast Wake-up mode really reduces the wake-up time. This is done by enabling all LDOs at the same state and checking for just core and radio voltage levels before proceeding to the next state. Waking up in this mode also de-asserts the COLD_BOOT flag.

Latency of this mode should be no more than 300 μs. The timing diagram is presented in Figure 11.

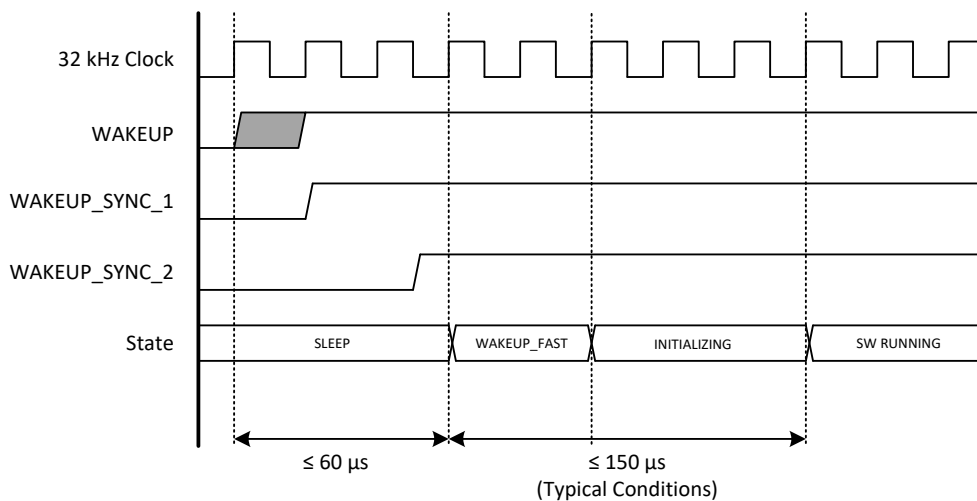

Figure 11. Fast wake-up timing

This mode should be selected if the system is in Sleep mode for time intervals less than 4 seconds.

6.3.3.3 Ultra-Fast Wake-up

An ultra-fast Wake-up mode is implemented to further reduce wake-up time down to ~100 μs. If this mode is activated, no checking is performed on LDO feedback signals. It is assumed that core voltage level is ok and thus CPU is allowed to run right after a couple of low power clock cycles required for sampling the wake-up trigger event whether it comes from a GPIO or an internal timer. Figure 12 shows the timing diagram of the ultra-fast wake-up.

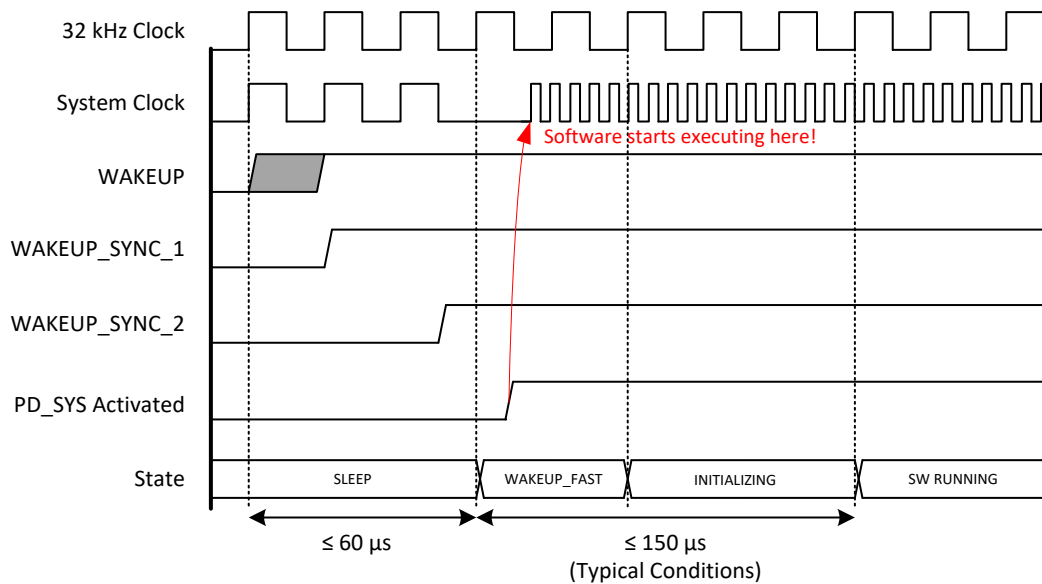

Figure 12. Ultra-fast wake-up timing

Hardware FSM is still implementing a "Fast WAKEUP" in parallel as shown in the timing diagram under the "State" signal. Until the RUNNING state is entered (which designates that power is indeed ok and more current can be dissipated), it is recommended that the CPU runs at 32 MHz (using the internal RC32MHz) and not at higher frequencies (PLL). It is also recommended not to enable external devices powered by the DA1469x while the internal LDOs are not properly activated (State has reached "Software Running").

6.3.4 Go-To-Sleep

The DA1469x can go to deep sleep only if the Power Domain Controller (see Section 8) has no pending activity from any of the three masters of the system. If this is the case, then the system enters the sleep state where two operations can be configured to happen on a periodic basis:

1. Refresh the reference of the LDO_CORE_RET which provides the sleep voltage by activating the bandgap every $\text{PMU_SLEEP_REG}[\text{BG_REFRESH_INTERVAL}]$ low power clocks.
2. Check on the voltage levels by allowing the BOD to sense each voltage rail while the bandgap is enabled. BOD is then running on a 1 MHz clock derived by the RC32M oscillator. Detailed timing diagrams can be found at Section 9.

The exact configuration of LDOs while getting from RUNNING into SLEEP can be found in Table 68.

6.4 Power Modes and Rails

There are four Main Power modes in the DA1469x family:

Hibernation mode. This is the Shipping mode. There is no RAM retained, no clocks running (so no RTC), all domains are off, the system can only be woken up by POR, hardware reset or a GPIO trigger. To enter this mode, RC32K must be selected as the low power clock. This is the oscillator started after a GPIO trigger that wakes up the complete system. When woken up, the system resets.

Deep Sleep mode. No RAM is retained, XTAL32K is running (so RTC is on), all domains are off, the system can only be woken up by POR, RTC alarm or a GPIO trigger.

Extended Sleep mode. Programmable RAM can be retained, XTAL32K/RCX is running (so RTC is ON or OFF depending on the sleep clock), all domains are OFF, the system can only be woken up by POR, RTC alarm (if XTAL32K is used), MAC timer, other Timer or a GPIO trigger.

Active/Idle. System is up and running, with a number of power domains enabled depending on the use case. For Sensor Node, for instance, PD_COM and the PD_MEM is enabled. If Cortex-M33 processing power is needed, for example, then all domains might be enabled.

Note that there is no state retention at the CPU, so it always wakes up in RESET state. Required registers have to be saved and restored to/from RAM upon waking up.

Multi-Core Bluetooth 5.2 SoC Family with System PMU

A number of different power rails are supplied in the DA1469x family power management. A detailed description of the architecture can be found in the power architecture diagram. The actual rail supply, driving elements, and configuration capabilities are presented in [Table 68](#).

Table 68: Power Rails Configuration

Rail	Supplied by	V_OUT (V)	I_LOAD (mA)	Activation register(s)	Hardware wake-up FSM	Hardware Go-to-sleep FSM	Remarks
V30	LDO_VBAT_RET	3/3,3/3,45	10	LDO_3V0_RET_ENABLE_ACTIVE LDO_3V0_RET_ENABLE_SLEEP	Programmable	Programmable	Precise voltage: 3V and approximate voltage: 3V45 available. If LDO_3V0_RET_ENABLE_SLEEP =1 is set, the LDO will be used in sleep. If LDO_3V0_RET_ENABLE_ACTIVE =1 is set, it will be used in active. Reset value is enabled in sleep, disabled in active
	LDO_VBAT	3/3,3/3,45	150	LDO_3V0_MODE	Programmable	OFF	Only used in active. Four settings: 0: Disabled 1: Always use LDO_VBAT 2: Always use LDO_VBUS 3: Automatically select depending on VBUS level
	LDO_VBUS	3/3,3/3,45	150	LDO_3V0_MODE	Programmable	OFF	Same as above
	VSYS_CLAMP	~2,4	1	CLAMP_3V0_VBAT_ENABLE	Programmable	Programmable	This clamp could be used for minimum current dissipation, provided that there are no external components powered by the PMU, both at V30, as well as V18 or V18P. Clamp so voltage depends on temperature, processing, load, etc. This clamp cannot supply appreciable loads
Vcont	VCONT_CLAMP	~2,4	0,01		Always on	Always on	This is an internal rail supplying the RCX

Rail	Supplied by	V_OUT (V)	I_LOAD (mA)	Activation register(s)	Hardware wake-up FSM	Hardware Go-to-sleep FSM	Remarks
V18	LDO_IO	1,2/1,8	50	LDO_1V8_ENABLE	Programmable	OFF	
	LDO_IO_RET	1,2/1,8	10	LDO_1V8_RET_ENABLE_SLEEP LDO_1V8_RET_ENABLE_ACTIVE	Programmable	Programmable	Same functionality as with LDO_VBAT_RET
	DCDC_V18	1,2/1,8	50	DCDC_V18_ENABLE_HV/LV	N/A	N/A	DCDC output is always handled by the application SW
V18P	LDO_IO2	1,8	50	LDO_1V8P_ENABLE	Programmable	OFF	
	LDO_IO_RET2	1,8	10	LDO_1V8P_RET_ENABLE_SLEEP LDO_1V8P_RET_ENABLE_ACTIVE	Programmable	Programmable	Same functionality as with LDO_VBAT_RET
	DCDC_V18P	1,8	50	DCDC_V18P_ENABLE_HV/LV	N/A	N/A	DCDC output is always handled by the application software
V18F	Follows V18P	Follows V18P	50	SW_1V8F_ENABLE	Programmable	OFF	This is a different pin connected to the V18P rail through a switch. The <i>switch</i> is controlled by SW_1V8F_ENABLE
V12	LDO_CORE	0,9/1,2	50	LDO_CORE_ENABLE	Programmable	OFF	For 32 MHz operation, a 0.9 V setting should be used. If 96 MHz is required, then LDO_CORE should be switched to 1.2 V prior to enabling the PLL
	LDO_CORE_RET	0,75/0,9	1	LDO_CORE_RET_ENABLE_SLEEP LDO_CORE_RET_ENABLE_ACTIVE	Programmable	Programmable	Same functionality as LDO_VBAT_RET. Core can run on this LDO when it is programmed at 0.9 V and load is low (ultrafast WAKEUP)
	VDD_CLAMP	0,8 – 1,1	0,01		Always on	Always on	This is only used at STARTUP to

Rail	Supplied by	V_OUT (V)	I_LOAD (mA)	Activation register(s)	Hardware wake-up FSM	Hardware Go-to-sleep FSM	Remarks
							supply the AON power domain. Voltage level can be trimmed by CLAMP_VDD_LE VEL[3:0]
	DCDC_V12	0,9/1,2	50	DCDC_VDD_ENABLE_HV/LV	N/A	N/A	DCDC output is always controlled by the application software
V14	LDO_RADIO	1,2 – 1,55 50 mV steps	20	LDO_RADIO_ENABLE	Programmable	OFF	Activated by the <i>booter</i> (if cold boot) or by the application SW (if WAKEUP). Turned off by FSM in sleep
	DCDC_V14	1,2 – 1,55 50 mV steps	20	DCDC_V14_ENABLE_HV/LV	N/A	N/A	DCDC output is always controlled by the application software

6.5 OTP

6.5.1 OTP Segments

The OTP consists of several different segments which are described in the following table.

Table 69: OTP layout

Segment	Bytes	Description	OTP address
1	1024	Configuration Script ~100 registers write operations	0x00000C00
2	256	QSPI FW Decryption Keys Area – Payload write/read protected when secure mode enabled in CS Secure mode connects those (8 * 256-bits) keys to QSPI Controller	0x00000B00
3	256	User Data Encryption Keys – Payload Write/Read protected when secure mode enabled in CS. Secure mode connects those (8 * 256-bits) keys to AES engine	0x00000A00
4	32	QSPI FW Decryption Keys Area – Index Eight entries for eight 256-bit keys	0x000009E0
5	32	User Data Encryption Keys – Index 8 entries for 8 256-bit keys	0x000009C0
6	256	Signature Keys Area – Payload	0x000008C0
7	32	Signature Keys Area – Index	0x000008A0
8	2208	Customer Application Area (Secondary bootloader, binaries, and so on)	0x00000000

Segment 1 contains the "Configuration Script" of the system. This is a script with a certain format, which is mainly executed by the booter.

6.5.2 Configuration Script

It is a table of 32-bit entries, X spaces deep. X cannot be longer than 256 places (It means that the CS can use 1 kB of total space).

The script is used for programming registers with values that are defined during production testing, storing a trim value for the application software, and defining UART time-out time during booting. The booter executes the script to prepare and initialize the system before the CPU starts running application code from the FLASH.

The format of the commands in the script is one of the seven cases from [Table 70](#).

Table 70: Configuration Script Commands and Description

#	Command type	Description
1	Start command	One 32-bit word containing 0xA5A5A5A5 to signal a valid CS is in place
2	Register configuration	One 32-bit word containing an address of an existing register One 32-bit word containing the data value of the register. These are always in pairs with the address sitting in even memory addresses
3	Trim value	<ul style="list-style-type: none"> ▪ One 32-bit word which is equal to 0x9000YYXX indicating that the next word is a value stored during production testing. More specifically: <ul style="list-style-type: none"> • 9: indicates that the following word(s) are not to be stored to registers but will be used by the SDK SW • YY: indicates that YY amount of words follow • XX: is an increasing value and can be used for indexing by the SW application. If YY>1 then this number will not be increased for the words that belong to the same value ▪ One or more 32-bit words which represent the value

#	Command type	Description
4	Booter value	One 32-bit word which is equal to 0x6XXXXXXXXX indicating this is a value pointing to the Flash product header in flash at address 0XXXXXXXXX
5	Development mode disable	One 32-bit word which is equal to 0x70000000, disabling the development mode. Development Mode is enabled by default at the initialization phase of the booter
6	UART STX Timeout	One 32-bit word which is equal to 0x8XXXXXXXXX. The XXXXXXXX is used to program the selected STX timeout in multiples of 100 µs. That is 0x80000040 is 40x100 µs = 4 ms
7	Stop command	One 32-bit word containing 0x00000000 designating that the configuration script has reached the end and execution should be terminated

The above-mentioned cases are summarized in the following table, illustrating an example.

Table 71: Configuration script example

Words	Even words	Odd words	Description
0-1	0xA5A5 A5A5	0x8000 0028	Starts command of the CS Script, followed by STX timeout value of 4 ms (40x 100µs)
2-3	<Address>	<Value>	Booter automatically writes to <Address>, the <Value>
4-5	0x9000 0301	<Value>	Three calibration values stored during Production Testing. SDK should know what this is for
6-7	<Value>	<Value>	
8-9	<Address>	<Value>	Booter automatically writes to <Address>, the <Value>
10-11	<Address>	<Value>	Booter automatically writes to <Address>, the <Value>
12-13	0x9000 0402	<Value 1>	Four calibration values stored during Production Testing. SDK should know what this is for
14-15	<Value 2>	<Value 3>	Calibration value stored during Production Testing. SDK should know what this is for
16-17	<Value 4>	0x6000 1000	Booter value: address of the product header in flash
18-19	0x7000 0000	0x0000 0000	Disables development mode command, followed by Stop command. Booter will stop running script after stop command so anything after this is don't care

6.5.3 Keys and Indexing

There are three different groups of keys in the OTP, namely:

- The QSPI firmware decryption keys group
- The user application symmetric keys group
- The signature keys group

The first contains the keys that can be used for decryption-on-the-fly while the CPU is executing code in place from the Flash with help of the cache controller. The second, contains user defined keys that can be used by the application with help of the crypto block (AES accelerator). The last, contains public keys used for authentication of the Flash image while booting (Secure Boot).

Each group has its own index section. There are eight entries in every index section, each entry is initially 0xFF. Every index entry corresponds to a 256-bit key. If an entry is written with 0x00, then the respective key is revoked and hence not used anymore. Revocation is only done through the booter, as explained in Section 6.7.4.

6.5.4 Customer Application Area

A 2 kB space can be used for a small secondary bootloader that runs a limited amount of software. The system can be programmed to remap address zero to the OTP base address. So right after booting, the CPU will start executing code from the OTP base address.

6.6 Flash

The Flash is partitioned in regions so that it can support multiple images in one Flash device and let the cache controller remap to them individually. By default, the Flash region size is set at 0.5 MB, but this can be defined in the configuration script by programming the `CACHE_FLASH_REG[FLASH_REGION_SIZE]`.

All different firmware images start at a region aligned address. The first region is not used for a Flash image but reserved for the product header. This contains important information about the system and Flash type.

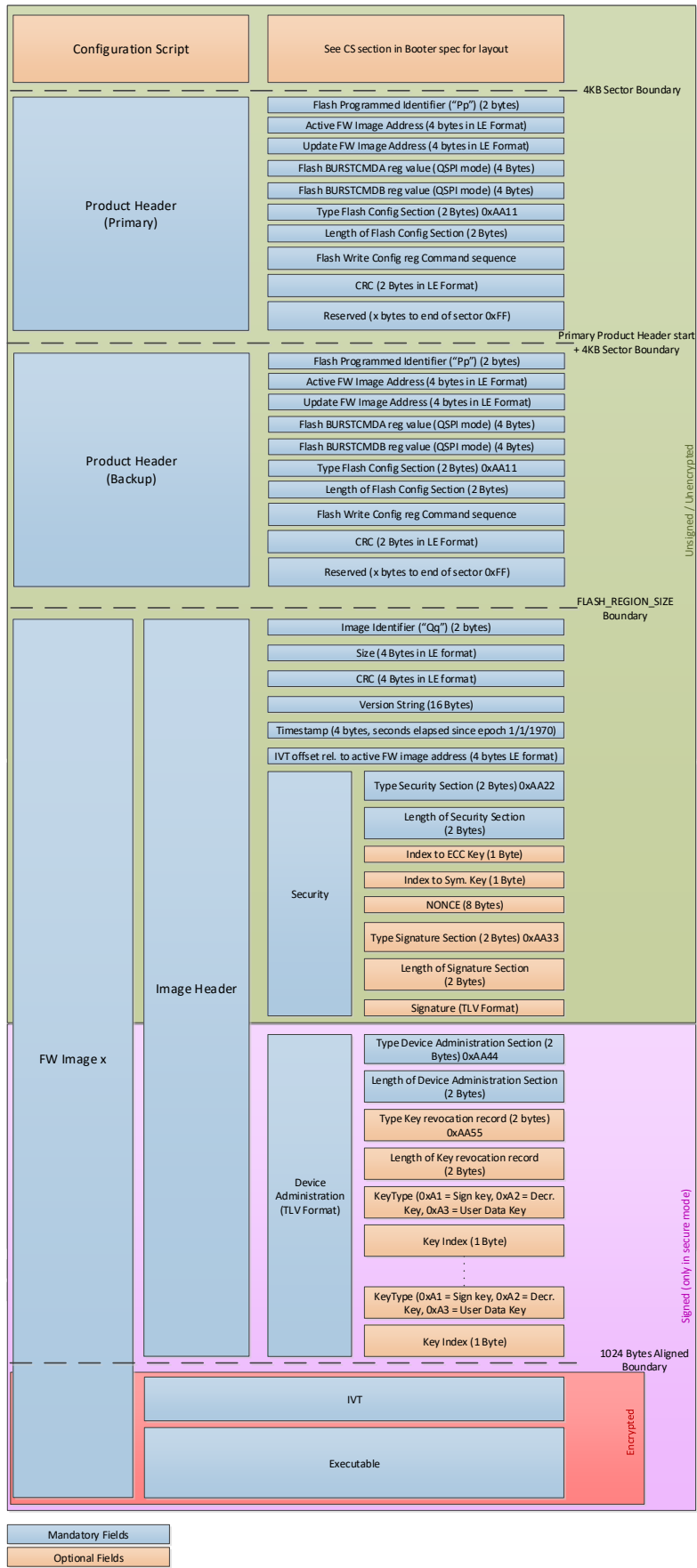

Figure 13. Flash regions and layout

In Figure 13, orange stands for optional while blue for mandatory fields.

Padding of 0xFF is used between the end of the Image header and the start of the Image itself. Image is always 1 kB aligned.

In case the image header contains a Device Administration section, the signature is calculated over this section, the padding, and the image. On the other hand, if Device Administration section is not included, the signature will be calculated over the image only.

6.7 Booting

The booter is always executed when a POR, a hardware Reset or the RESET_ON_WAKEUP feature is configured. Different booting flavors are supported:

- Boot from cached QSPI flash without secure features, configuration script in OTP
- Boot from cached QSPI flash without secure features, configuration script in flash
- Boot from cached QSPI flash with secure features, configuration script in OTP
- Boot from UART without flash or secure features
- Boot from OTP without flash or secure features

The booter also detects available software updates and apply them according to the Flash header. Note that the booter cannot boot a flash image if the Product Header or the active image partition is beyond the 128-Mbit address (0x1000000) in the flash. This happens because the flash opcode that allows for reading addresses larger than 24 bits is not unified across all flash vendors.

The Boot flow is divided into five separate phases:

- Initialization
- Run Configuration Script
- Retrieve application code
- Device administration
- Load image

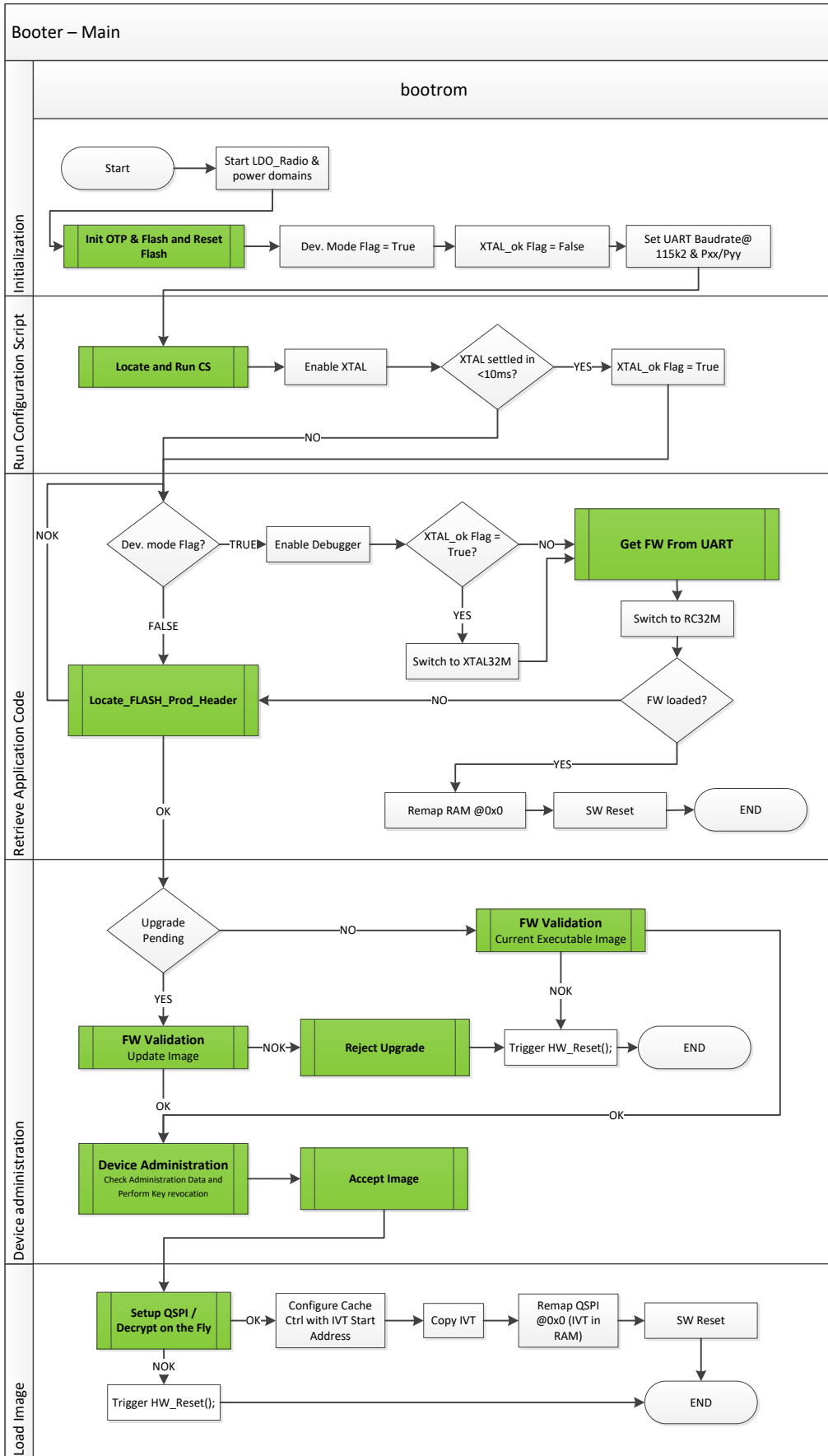

Figure 14. BootROM flowchart

6.7.1 Initialization

The initialization phase takes care of starting the LDO_radio and enabling the Power domains. Then it initializes the OTP Controller, QSPI interface and Clocks. Following this, it enables Development mode. This is done so that it can be disabled by the CS in the next phase if desired. Development mode can be used for having the debugger on and update the device firmware using the UART.

Next it sets the XTAL_ok flag to "False" (it is set to "True" if the XTAL settled correctly at a later phase).

Finally, the booter initializes the UART (but not enable it yet) with the default settings, which can still be overwritten by the configuration script residing in the OTP.

6.7.2 Configuration Script

This phase tries to locate and execute the Configuration Script (CS) from OTP or flash. It is expected to be at address 0x00000C00 in OTP, or at the start of the QSPI flash. If none is found the booter just continues to the next step assuming that there is no configuration script in place.

The way a CS is detected is by looking at the location where it is expected and verify if the CS Start command is found. If a CS is found, either in OTP or flash, it is parsed and executed. It stops parsing when any of the following happens:

- It reaches the stop command.
- It reaches the first empty entry.
- It reaches the maximum length.

After the CS is processed, XTAL32M is enabled and the booter checks if the settle and trim ready bits are set within 10 ms. If not, the XTAL_ok flag remains "False". If settled correctly it sets to "True". This flag is later used to detect if it is safe to switch to XTAL32M, or to continue using the default system clock: RC32M.

6.7.3 Retrieve Application Code

During this phase, the booter scans to check if the development mode flag is disabled or not. If it is still in Development mode, then it enables the Debug interface and try to boot from UART. If booting from UART is successful, then it issues a software reset after having remapped address zero to RAM. If not, then it tries to locate a valid Flash header, trying to boot from flash.

If not in Development mode, the booter continues to the next phase after having identified a valid product header in the flash. A valid product header is identified by a programmed Flash programmed identifier and an Active Firmware Image Address as shown in [Figure 13](#).

6.7.4 Device Administration

The device administration phase is used to check for pending updates and validate the Flash images. It also, processes corresponding image headers and revoke keys, if needed.

The booter checks if the Active Firmware Image address and the Upgrade Image address fields of the Flash product header are the same. If not, an upgrade image is available. The firmware validation is executed if the secure boot bit is already set by the Configuration Script (CS). Validation is done by identifying the public key, checking if the key is already revoked and if not, proceed with invoking the Ed25519 verification algorithm. This happens with the PLL being enabled and the system CPU running at 96 MHz.

After the image is authenticated, the booter checks for any "key revocation record" in the Flash image. This triggers revocation of the key that is currently in use. The key revocation requires an OTP write as explained in [Section 6.5.3](#).

6.7.5 Load Image

In this final phase, the actual firmware image is loaded. This is done by setting up the QSPI and cache controllers and executing the QSPI Loader, which is located in the Product header of the flash. If secure boot is enabled, the QSPI controller initializes to decrypt on the fly. The cache controller is then configured to point to the interrupt vector table (copied in RAM) and address zero are remapped to QSPI flash. Any error condition during this or previous phases, results in a hardware reset.

6.8 Memory Map

The mapping of the system's internal resources is presented in the following table. *_C defines a Controller (registers) while *_M defines Memory (RAM) space. All resources are 32-bit aligned.

Table 72: Memory map

Resource	Start address	End address	Size (kB)	PD	AMB A	Comments
Remapped Devices	0	800000	8192	PD_SYS	AHB	Remap IVT into SYSRAM
SYSRAM (code)	800000	880000	512	PD_MEM	AHB	Remapped at 0x0. DA14691 end address: 0x860000
Reserved						
ROM	900000	920000	128	PD_SYS	AHB	Remapped at 0x0
Reserved						
CACHE_RAM	1006000 0	10064000	16	PD_SYS	AHB	
Reserved						
OTPC_C	1007000 0	10080000	64	PD_SYS	AHB	
OTPC_M	1008000 0	10090000	64	PD_SYS	AHB	First 4 kB Remapped at 0x0
Reserved						
CACHE_C	100C000 0	100C0100	0,25	PD_SYS	AHB	
Reserved						
QSPIF_M	1600000 0	18000000	3276 8	PD_SYS	AHB	First 8 ms Remapped at 0x0
QSPIF_C	1800000 0	1A000000	3276 8	PD_SYS	AHB	
Reserved						
SYSRAM (data)	2000000 0	20080000	512	PD_MEM	AHB	Same physical address as SYSRAM(code)
Reserved						
AHB_DMA_B	3002000 0	30020400	1	PD_SYS	AHB	
Reserved						
LCD_C	3003000 0	30040000	64	PD_SYS	AHB	
AES_HASH_C	3004000 0	30050000	64	PD_MEM	AHB	
TRNG_M	3005000 0	30060000	64	PD_SYS	AHB	
Reserved						
OTPC_C	3007000 0	30080000	64	PD_SYS	AHB	Same physical address as 0x10070000
OTPC_M	3008000 0	30090000	64	PD_SYS	AHB	Same physical address as 0x10080000 (Note 1)

Multi-Core Bluetooth 5.2 SoC Family with System PMU

Resource	Start address	End address	Size (kB)	PD	AMB A	Comments
PATCH	30090000	30090800	2	PD_SYS	AHB	
Reserved						
QSPIR_M	32000000	34000000	32768	PD_SYS	AHB	
QSPIR_C	34000000	36000000	32768	PD_SYS	AHB	
QSPIF_M	36000000	38000000	32768	PD_SYS	AHB	Same physical address as 0x16000000 (Note 1)
QSPIF_C	38000000	3A000000	32768	PD_SYS	AHB	Same physical address as 0x18000000
Reserved						
CMAC	40000000	40020000	128	PD_RA D	AHB	
RFCU	40020000	40020200	0,5	PD_RA D	AHB	
RFCU_POWER	40020200	40021000	3,5	PD_RA D	AHB	
DEMODO	40021000	40022000	4	PD_RA D	AHB	
SYNTH	40022000	40023000	4	PD_RA D	AHB	
Reserved						
CRG_AON	50000000	50000100	0,25	PD_AO N	APB3 2	
WKUP	50000100	50000200	0,25	PD_AO N	APB3 2	
PDC	50000200	50000300	0,25	PD_AO N	APB3 2	
DCDC	50000300	50000400	0,25	PD_AO N	APB3 2	
RTC	50000400	50000500	0,25	PD_AO N	APB3 2	
Reserved						
WDOG	50000700	50000800	0,25	PD_TIM	APB3 2	
Reserved						
XTAL32M_C	50010000	50010200	0,5	PD_TIM	APB3 2	
TIMER	50010200	50010300	0,25	PD_TIM	APB3 2	
TIMER2	50010300	50010400	0,25	PD_TIM	APB3 2	
MAC_TIM	50010400	50010500	0,25	PD_TIM	APB3 2	
Reserved						

Multi-Core Bluetooth 5.2 SoC Family with System PMU

Resource	Start address	End address	Size (kB)	PD	AMB A	Comments
UART	5002000	50020100	0,25	PD_CO M	APB3 2	
UAR2	5002010	50020200	0,25	PD_CO M	APB3 2	
UART3	5002020	50020300	0,25	PD_CO M	APB3 2	
SPI	5002030	50020400	0,25	PD_CO M	APB3 2	
SPI2	5002040	50020500	0,25	PD_CO M	APB3 2	
Reserved						
I2C	5002060	50020700	0,25	PD_CO M	APB3 2	
I2C2	5002070	50020800	0,25	PD_CO M	APB3 2	
SDADC	5002080	50020900	0,25	PD_CO M	APB3 2	
CRG_COMM	5002090	50020A00	0,25	PD_CO M	APB3 2	
GPIOMUX	50020A0	50020C00	0,5	PD_CO M	APB3 2	
SENSORN_C	50020C0	50020D00	0,25	PD_CO M	APB3 2	
SENSORN_M	50020D0	50020E00	0,25	PD_CO M	APB3 2	
Reserved						
PWMWLED	5003050	50030600	0,25	PD_PER	APB3 2	
SRC/PDM	5003060	50030700	0,25	PD_PER	APB3 2	
PCM	5003070	50030800	0,25	PD_PER	APB3 2	
TEMPSENSE	5003080	50030900	0,25	PD_PER	APB3 2	
GPADC	5003090	50030A00	0,25	PD_PER	APB3 2	
LRA	50030A0	50030B00	0,25	PD_PER	APB3 2	
ANAMISC	50030B0	50030C00	0,25	PD_PER	APB3 2	
CRG_PER	50030C0	50030E00	0,5	PD_PER	APB3 2	
SMOTOR	50030E0	50030F00	0,25	PD_PER	APB3 2	
Reserved						
USB_C	5004000	50040200	0,5	PD_SYS	APB3 2	

Resource	Start address	End address	Size (kB)	PD	AMB A	Comments
VERSION	50040200	50040300	0,25	PD_SYS	APB3 2	
GPREG	50040300	50040400	0,25	PD_SYS	APB3 2	
CHARGER	50040400	50040500	0,25	PD_SYS	APB3 2	
CRG_2	50040500	50040600	0,25	PD_SYS	APB3 2	
RFMON	50040600	50040700	0,25	PD_SYS	APB3 2	
Reserved						
DMA_C	50040800	50040A00	0,5	PD_SYS	APB3 2	
TIMER3	50040A00	50040B00	0,25	PD_SYS	APB3 2	
TIMER4	50040B00	50040C00	0,25	PD_SYS	APB3 2	
TRNG_C	50040C00	50040D00	0,25	PD_SYS	APB3 2	
Reserved						
MEMCTRL_C	50050000	50050100	0,25	PD_ME M	APB3 2	
Reserved						
Arm Internal Bus	E0000000	FFFFFFF		PD_SYS		

Note 1 Access to QSPI flash memory from peripherals (for example, DMA), is done through 0x36000000 memory space and access to OTP memory through 0x30080000.

6.9 Resource Sharing

The DA1469x has three processing units that might request access to one or more of the system's peripheral controllers. The application software can map certain resources to one of the processing units. But there are times, for example, when CMAC needs to use the General-Purpose ADC to read the die temperature and trigger a radio calibration, while the same ADC is required by the application software running a State of Charge algorithm by checking the Battery Voltage on a regular basis.

To avoid race conditions and provide all three processing units with a robust way of identifying who the owner of the peripheral is, a hardware mutex is implemented. This is a 32-bit register (BUSY_STAT_REG) which can be set/reset by using write only registers (BUSY_SET_REG) and (BUSY_RESET_REG). This stops race conditions happen because two processing units are writing at the same time. Two bits are reserved per resource, so that the value represents the owner of the resource:

- 0x0: resource is available for use
- 0x1: resource is busy, controlled by the Sensor Node Controller
- 0x2: resource is busy, controlled by the Cortex-M33
- 0x3: resource is busy, controlled by the CMAC

Such a mutex register, which decides resources that require sharing, can be defined by application software. [Table 73](#) shows a possible configuration of such a register.

Table 73: Busy status register

31-30	28-29	26-27	24-25	22-23	20-21	18-19	16-17	14-15	12-13	10-11	8-9	6-7	4-5	2-3	0-1	Bit
RESERVED	Motor Controller	Timer2	Timer	UART3	ADC	PDM	SRC	PCM	ADC2	I2C2	I2C	SPI2	SPI	UART2	UART	

The register is in the PD_MEM, which is automatically activated if one of the three master's is alive. However, if the system is in deep sleep, then this register is not retained.

6.10 Remapping

Remapping options are explained in the following table:

Table 74: Remapping options

Remap Field in the SYS_CTRL_REG – 3 bits	
0x0	Remap address 0 to ROM
0x1	Remap address 0 to OTP
0x2	Remap address 0 to flash cached area
0x3	Remap address 0 to SysRAM1
0x4	RESERVED
0x5	Remap address 0 to SysRAM2
0x6	Remap address 0 to Cache RAM
0x7	RESERVED

In the case of Flash cached (default use case), CACHE_FLASH_REG contains the base address and offset of the Flash image.

6.11 Security Features

The DA1469x supports a number of security features that can be configured. This is done using the configuration script to program the following write-one-only (sticky) register bits (these bits can only be reset by hardware or PORreset):

Table 75: Security configuration options

Bit field	Description
FORCE_DEBUGGER_OFF	This bit permanently disables the M33 debugger
FORCE_CMAC_DEBUGGER_OFF	This bit permanently disables the CMAC debugger
PROT_QSPI_KEY_READ	This bit permanently disables CPU read capability at OTP offset 0x00000B00 and for the complete segment
PROT_QSPI_KEY_WRITE	This bit permanently disables ANY write capability at OTP offset 0x00000B00 and for the complete segment
PROT_AES_KEY_READ	This bit permanently disables CPU read capability at OTP offset 0x00000A00 and for the complete segment. The AES sections are only used by the application software, but protecting the key area from read/write makes it secure after leaving the manufacturing facilities
PROT_AES_KEY_WRITE	This bit permanently disables ANY write capability at OTP offset 0x00000A00 and for the complete segment. The AES sections are only used by the application software, but protecting the key area from read/write makes it secure after leaving the manufacturing facilities

Bit field	Description
PROT_SIG_KEY_WRITE	This bit permanently disables ANY write capability at OTP offset 0x000008C0 and for the complete segment. This is for protecting public keys from being written (used by ECC only)
SECURE_BOOT	This bit enables authentication of the image in the flash while the system is booting

6.11.1 Secure Keys Manipulation

This feature allows for programming up to eight different 256-bit symmetric keys for each of the encrypted image or the user application cases and up to eight different 256-bit ECC keys for the authentication of the flash image. A revocation mechanism is supported through the booter as explained in previous sections allowing for changing the current key of any of the three operations while the product is in the field.

6.11.2 Secure Boot

The feature is enabled by programming the SECURE_BOOT_REG[SECURE_BOOT] bit in the configuration script in the OTP.

This forces authentication of the Flash image before booting is finished. The booter code starts the PLL switch the system clock to 96 MHz and then execute the Ed25519 verification algorithm. If the generated signature and the signature stored in the Flash match, authentication is successful, and booting is continued. If not, a hardware reset is issued.

The aforementioned process represents the FIRMWARE VALIDATION state in [Figure 14](#).

6.11.3 Secure Access

Permanently disabling the JTAG interface, prevents unwanted access to the DA1469x. This is done by programming the SECURE_BOOT_REG[FORCE_DEBUGGER_OFF] in the configuration script. This disconnects the SWD signals from the CPU's SWD controller.

Except for the sticky bit, the debugger has its own enable bit; namely, the SYS_CTRL_REG[DEBUGGER_ENABLE] which is by default disabled. This bit is enabled during booting, at the "Retrieve Application Code" phase (see [Figure 14](#)).

If nothing is programmed in the configuration script, JTAG is enabled a few microseconds after POWERUP. If the sticky bit is programmed, JTAG is permanently disabled.

6.11.4 Validation

Every device can be uniquely identified using the Position, Package, and Time Stamp information put in the configuration script during the production test. This is a 64-bit word, which contains information about the position of the die, the wafer number, the package, and the time stamp of the production testing that compared to the Tester ID and site.

6.11.5 Cryptography Operations

The DA1469x is equipped with HW acceleration for supporting all modern cryptography operations. More specifically, it comprises:

- A 256-bit capable AES encryption/decryption and key expansion engine that implements ECB/CBC/CTR modes covering all symmetric key application needs
- A complete HASH block supporting up to SHA 512 bits
- A real hardware True Random Number Generation, capable of generating 1024 random bits in 64k clock cycles

7. Power

Device:	DA14691	DA14695	DA14697	DA14699
Feature Availability:	✓	✓	✓	✓

7.1 Introduction

The DA1469x has a complete integrated Power Management Unit (PMU). This includes a Single Inductance Multiple Output (SIMO), a DC-DC converter with 4 outputs, a number of LDOs for the different power rails of the system, a Constant-Current-Constant-Voltage (CCCV) charger for battery recharging, and a charge detection circuit. The PMU can supply external devices even when the DA1469x is in sleep mode. Figure 15 shows the system diagram of the analog Power Management Unit (PMU).

Features

- Synchronous Single Inductance Multiple Output Buck DC-DC converter with 4 output power rails
- Programmable DC-DC converter output charging sequence
- Two DC-DC converter outputs at 1.8 V with 50 mA load capability for powering external devices
- One LDO output up to 3.3 V with up to 150 mA drive capability
- DC-DC converter ON/OFF control per output
- Active and Sleep mode current limited LDOs
- Use of small external components
- Supply of external rails (V30, VDD1V8, VDD1V8P) while DA1469x is in Sleep mode
- CC/CV Charger with battery/die-temperature protection
- Interrupt line for the DCDC converter

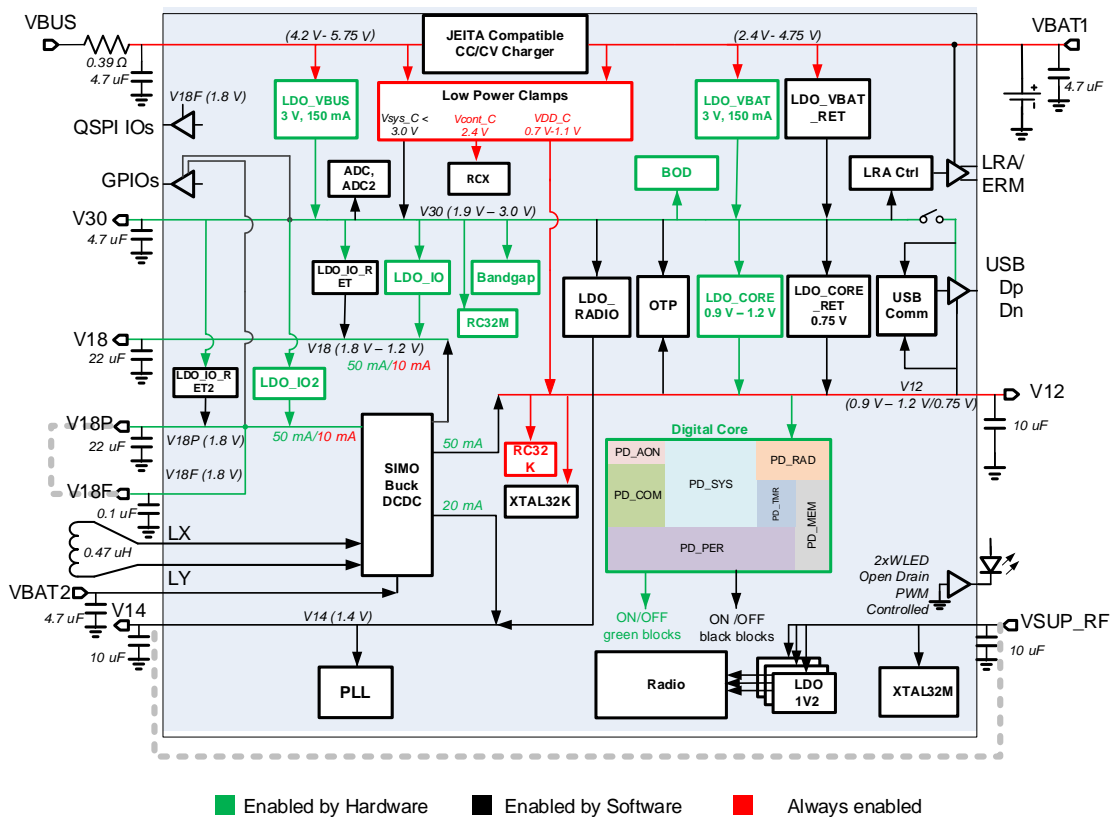

Figure 15. Power management unit architecture

ΦII decoupling capacitor values listed in Figure 15 are nominal.

7.2 Architecture

There are three main power inputs, namely VBUS, VBAT1, and VBAT2. The VBUS is connected when charging the battery through the USB connector. VBAT1 should be shorted with VBAT2 externally; it supplies the LDOs, while VBAT2 supplies the SIMO DCDC converter. There are certain parts of the PMU which are always powered. They are shown in red in Figure 15. The always-ON power circuitry has two clamps and LDO_SLEEP. This supplies the voltage needed when the system is in extended sleep, deep sleep, or hibernation mode. When the system wakes up, then many of the blocks of the PMU are activated automatically (shown in green). This is explained in the power/wake up sequence flow charts. Finally, is responsible for activating the SIMO DCDC and any other block shown in black in Figure 15.

The digital core is further divided into power domains as explained in the "System Overview" section. These domains are controlled by the Power Domains Controller.

7.2.1 SIMO DC-DC Converter

The heart of the PMU is the SIMO Buck DC-DC converter. Figure 16 shows the block diagram.

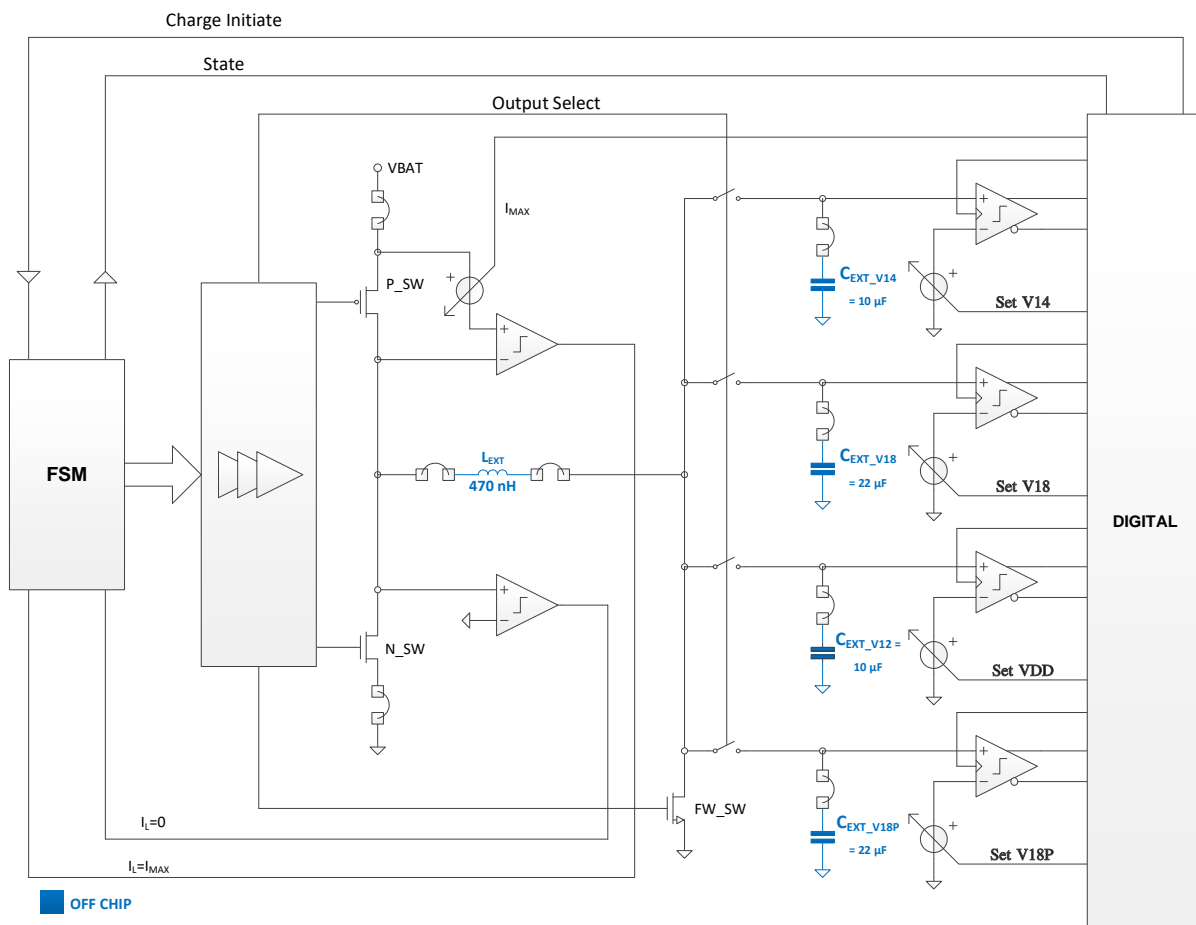

Figure 16. SIMO DCDC block diagram

The DCDC converter has four outputs:

- V18P which delivers 50 mA when DA1469x is in active. The voltage range of this power rail is 1.8 V +/- 5%. External devices or sensors that need to be constantly powered ON, should be connected to this power rail
- V18F which is used for supplying the external Quad SPI FLASH. This rail's characteristics are identical to the V18P
- V14 which is connected externally on the PCB with VSUP_RF and delivers up to 20 mA at 1.4 V and should not be used to supply external devices
- V12 that supplies the digital core of the DA1469x, and delivers up to 50 mA at 1.2 V when in Active mode. This rail should not be used to supply external devices

The converter has an asynchronous architecture - the ON-time of the switches is not determined by an external clock. Instead, the ON-time is determined by a (dynamically varying) current limit in the external inductor. If one of the output voltages is too low (determined using clocked comparators), a charge cycle is triggered.

However, it is possible for more than one output to be below minimum at the same time. In such a case, the system has to decide which output to charge first. This is done using a priority select register, which holds the sequence in which the outputs are charged. Each time one or more outputs require a charge cycle; the system sorts the outputs based on this priority register and loads this sequence in a four-tab shift register.

To minimize the ripple voltage on the outputs, the current limit is dynamically set during operation in Active mode. This is done by measuring how long each output is above its minimum value after a charge cycle. If this time is too long, more charge than required (given the load current) was stored on the output capacitor, so the current limit is reduced by one bit (LSB). However, when the output voltage drops too quickly, not enough charge was delivered to the output capacitor, so the current limit is increased by one bit (LSB).

7.2.2 LDOs

Several LDOs are used to provide a stable power supply to all rails, when the SIMO DCDC is not active (for example, in Sleep mode or during start up) or when the device is plugged onto a USB charger. Furthermore, bypassing the DCDC is also considered, when the external voltage on pin VBAT2 is at the edge of enabling an efficient step-down activity (< 2.3 V). This is done automatically by hardware or manually by software.

Two low-power LDOs (LDO_ret) one connected to VBUS and one to VBAT, provide power to the Vcont power line and hence to the LDO_sleep (which is a clamp actually). This LDO is responsible for providing the VDD supply during Sleep mode, which can be configured down to 0.75 V. This is basically the supply of the Always ON power domain (PD_AON) which is constantly powered, independently of active or any sleep mode.

In Sleep modes the retention LDOs might take over and make sure that the system is properly powered without the need of the DC-DC converter. The LDO_VBAT_RET provides power to the System supply line the LDO_SLEEP at Vcore, and LDO_IO_RET/LDO_IO_RET2 to the external 1.8 V power rails. There is no need to power the Vradio since it is not enabled in any of the sleep mode. The LDO_VBAT_RET, LDO_CORE_RET and LDO_IO_RETx circuits, are identical and operate in a sample and hold manner. They contain a reference voltage capacitance which is used to regulate the output voltage. However, due to leakage, this internal reference capacitor is discharged. To keep a stable voltage reference, a mechanism is built to start the Bandgap, sample the voltage reference in the LDOs, and shut it down again. This periodic operation is programmable in terms of timing with use of the BG_REFRESH_INTERVAL, which counts sleep clock ticks.

In Active mode, when external supply is between 1.7 V and 2.4 V and the DC-DC converter is bypassed (stepdown conversion not feasible due to low voltage), the LDO_VBAT provides power to the Vsys line and the LDO_IO/LDO_IO2, LDO_Core and LDO_radio to the 1.8 V rails, the Vcore and the Vradio, respectively.

Finally, when the system is connected to a USB charger, pin VBUS is the source of the power instead of pin VBAT1/VBAT2. The same path is used as with VBAT2, but the LDO_USB is responsible for providing the System supply line with power. This LDO is automatically switched on as soon as a VBUS>VBAT1 voltage is sensed.

7.2.3 Switching between DC-DC and LDOs

In general, when one of the masters of the system (M33, M0+ or SNC) needs to turn ON, the DCDC is allowed to do so. DCDC is not turned off by any master. When the system can go to sleep, thus activating the HW FSM, then the DCDC controller is automatically turned OFF, since its digital state machine lives in the PD_MEM which powers down.

DCDC will not be enabled by the hardware FSM. However, it will be enabled by SW, running on either the M33, the M0+ or the SNC. It is done by first enabling the DCDC engine (DCDC_CTRL1_REG[DCDC_ENABLE]) and then activating the respective output of the DCDC which is of interest (DCDC_Vxx_ENABLE_xV bits).

When the latter occurs, the other drivers of the same rail (namely the LDO or LDO_RET) are automatically disabled by hardware hence, there is never more than one driver on each power rail.

The LDOs are activated again after WAKEUP, by the hardware FSM according to the configuration in the POWER_CTRL_REG. During this time, the DCDC registers are reset.

7.2.4 Low Power Clamps

This block consists of clamps that are delivering power to the V30 rail and the V12 rail. These are simple low-power clamps, not regulators hence they do not keep the voltage stable under any load.

The V30 supply follows the VBAT or VBUS voltage with a threshold difference. Its main purpose is to be able to provide some current to the V30 and start the Bandgap while the system is powering up.

The V12 supply keeps the digital Always-ON block alive when in Hibernation mode. There is no need for the bandgap or any Sample and Hold retention LDO to be alive. This clamp is programmable and can be lowered during hibernation to reduce dissipation as much as possible.

7.2.5 Battery Check

The Battery Check (BATCHECK) features a programmable VBAT load current, which can be used to modulate the battery (Figure 17). The constant load is a programmable current source from 0 to 8 mA in steps of 1 mA. The accuracy is +/-2.7 %. The internal resistance of a battery can be monitored in this way.

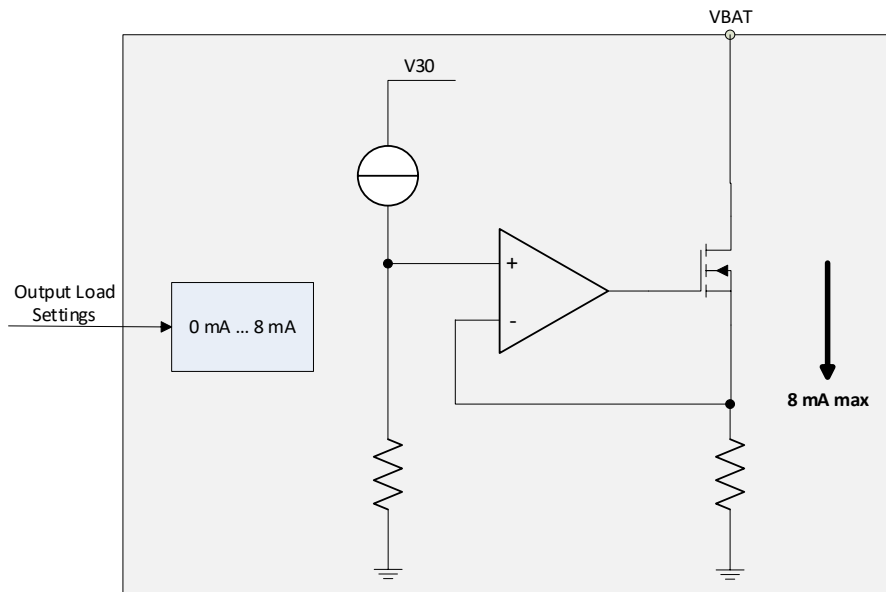

Figure 17. Battery check block diagram

The Battery Check contains the following functional blocks:

- Output load setting. Input is an accurate reference current from a bandgap; outputs are a number of (mirrored) currents.
- High gain op-amp
- Matched resistor network

It provides a reference current, coming from the bandgap, which is mirrored into selectable output current(s). This current is routed through a resistor, resulting in a reference voltage on the positive input of the op-amp. Due to the negative feedback and the high gain, the op-amp in combination with the output transistor try to force the same voltage on the negative input as well as over the output resistor, resulting in the selected output load current.

Register BATCHECK_REG controls the setting, fine tuning, and feature enablement.

7.2.6 Charger

Device:	DA14691	DA14695	DA14697	DA14699
Feature Availability:	x	✓	✓	✓

The integrated battery charger is suitable for charging different types of batteries (NiMH, Li-phosphate, Li-Co, Li-Mn, NMC). The charger uses an internal pass-device, which limits the external components to a minimum: Only an external buffer capacitor and a temperature-sensor (NTC) are needed.

The charger has a CCCV (Constant Current Constant Voltage) architecture and has battery temperature and chip-temperature protection. The charge levels are between 2.8 V and 4.9 V while the charge currents can be set between 5 mA and 560 mA (Normal charging) or 0.5 mA and 56 mA (Pre-Charge).

Enabling, disabling, and functional states of the charger are controlled by a HW state machine, exceptions and error handling is done via software. All protections and loops for current, voltage, and temperature are autonomous and implemented in hardware. There are indication signals towards the digital control for CC-mode, CV-mode, Die-temperature protection, Battery-temperature high, Battery- temperature low, Battery- temperature ok, and "End-of-Charge" (when the regulated charge current drops below 10% of the programmed value). Software can always monitor what is going on in the charger, but the function of the charger does not require a time-based software interaction. The charger control can be taken over by software if required at any point of the charging sequence.

A battery temperature sensing function is incorporated, using an NTC which guarantees JEITA compliance. This function determines the temperature zone of the battery. If the battery is too cold or hot, it automatically disables charging. Thresholds are programmable.

All essential measurements needed for the charger control (Vbat, battery temperature) are implemented in hardware, without the need to use any of the ADC channels and/or software.

The actual charger hardware FSM is illustrated in Figure 18.

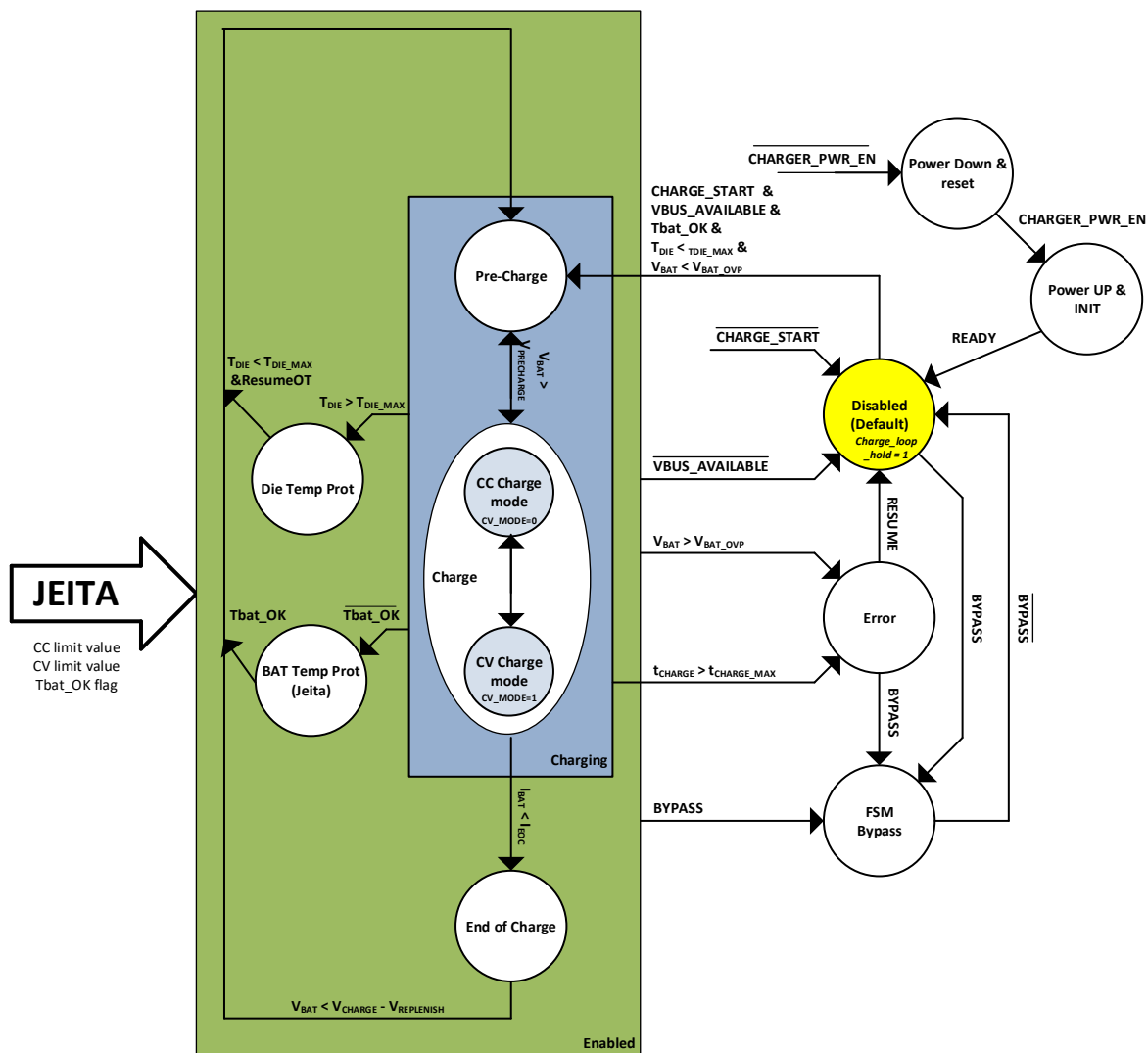

Figure 18. Charger hardware finite state machine diagram

7.2.6.1 JEITA

The JEITA standard defines a battery temperature dependent charge profile. In the normal temperature range, the charge current and voltage are at the maximum level for the selected battery. Above and below this normal

temperature range, there are two ranges in which the current (and optionally voltage) is reduced. At very low and very high battery temperatures, charging is stopped altogether. The battery temperature is determined using the NTC in the battery pack. This NTC is placed in series with an external resistor and a voltage is applied across them, creating a voltage divider. The output of this divider is compared to an internal reference that is created using a programmable resistor ladder that mimics the behavior of the NTC/resistor combination and has programmable taps at ~1 °C intervals, between -10 °C and +55 °C. The NTC battery monitoring connections are shown in Figure 19.

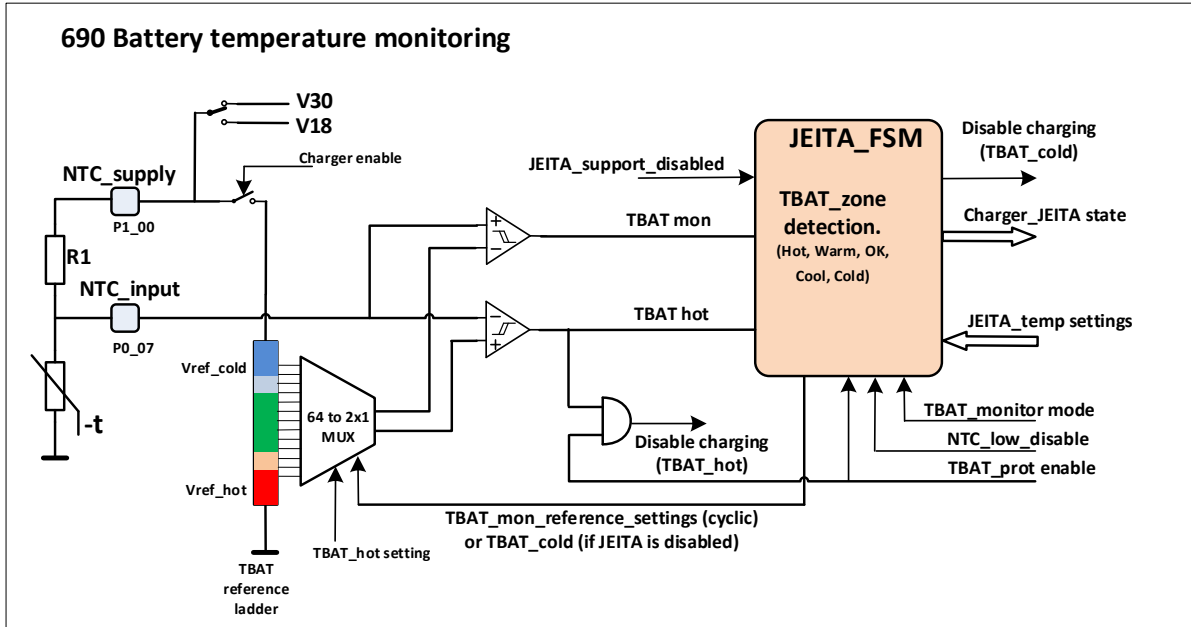

Figure 19. NTC battery monitoring connections

Figure 20. shows the Battery temperature monitoring FSM (JEITA_FSM).

NOTE

When using P1_00 as the supply for an NTC and P0_07 as the input for an NTC, both pins must be configured as GPIO's (Px_yy_MODE_REG[PID] = 0)
 P1_0 must be set as an output driving high and P0_07 as an input without pull-up or pull-down.

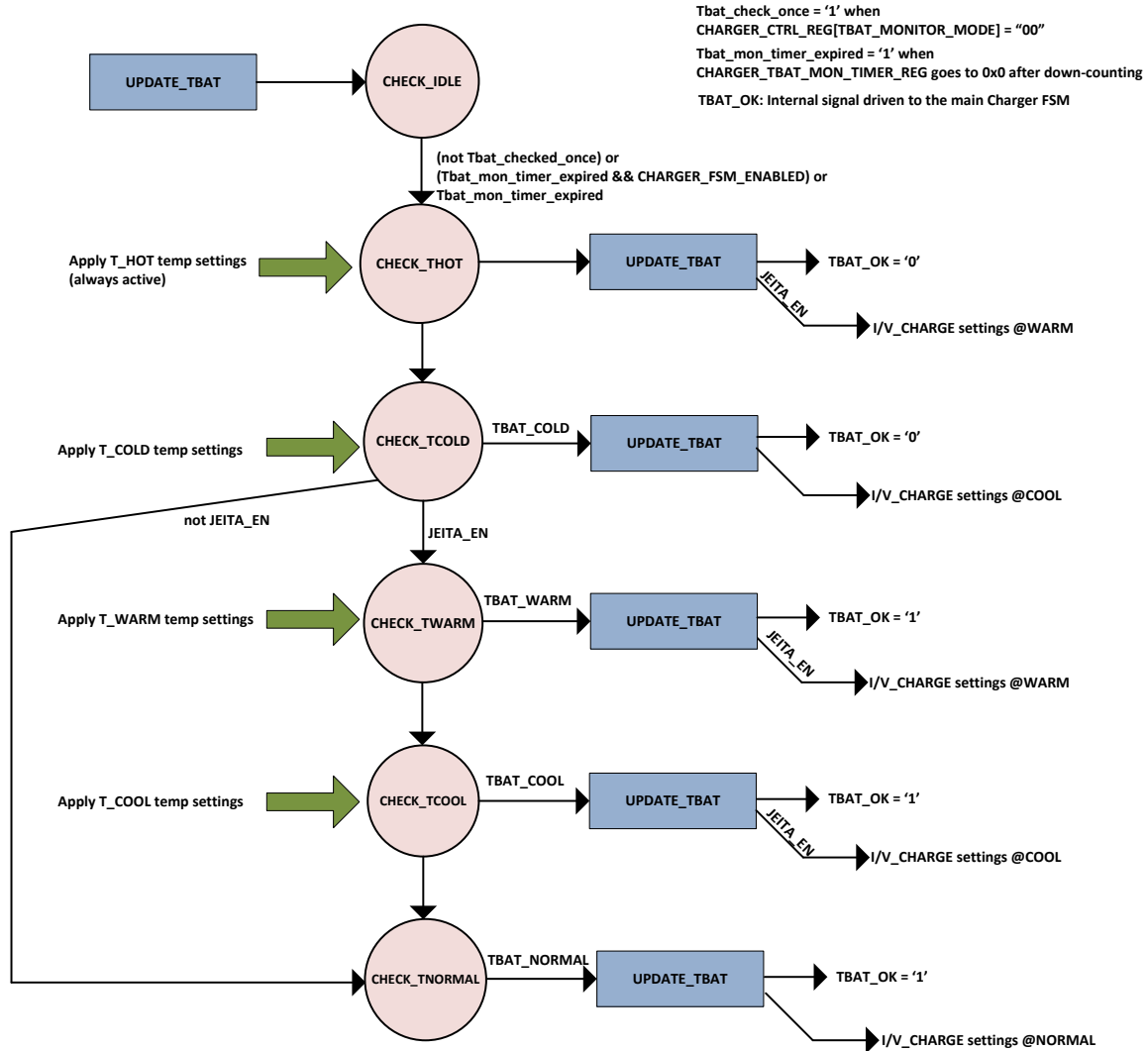

Figure 20. Battery temperature monitoring FSM

7.2.6.2 Errors and Flags

The following error conditions can be detected:

- Pre-charge timeout
- CC charge timeout
- CV charge timeout
- Total charge timeout
- Battery over-voltage
- Die temperature protection (error flag but not error state)
- Tbat_HOT and Tbat_COLD: Meaning that the Battery temperature is not OK
- Vbus available: Meaning that VBUS has been removed

The voltage and temperature errors get a direct path to shut down the charger loop.

The error flags are debounced before triggering a state change. Moreover, dedicated error handling routines can start on the assertion of these debounced signals.

Table 76 describes the error flags and when they are asserted.

Table 76: Charger error flags

Error flag	When asserted	Description
VBUS_AVAILABLE	Set if Vbus not present	Direct path to disable loop (part of wired OR with CHARGE_LOOP_HOLD), need for fast response time Needs debounce filter for state change If False, needs to disable charger loop If for some reason the bus is shorted, a high current path from battery to GND is present, that needs to be blocked as soon as possible Goes to DISABLE state from any charge state (green block in state diagram)
VBAT_OVP	Vbat too high	Directs path to disable loop (part of wired OR with CHARGE_LOOP_HOLD), need for fast response time Needs debounce /filter for state change Stops charging
DIE_OVER_TEMP	Set if die too hot	Directs path to disable loop (part of wired OR with CHARGE_LOOP_HOLD), need for fast response time. Debounces for digital. Stops charger, stop Counter set an ERROR_IRQ. Sets CHARGE_LOOP_HOLD Can start additional error routine. Default Resume_OT flag should be set. Resumes if temperature is lower again, set by internal threshold in Temp_protect circuit
Tbat_HOT	Tbat too high	Default output of battery temp block if not in monitor mode, direct path to disable charger loop
Tbat_COLD	Tbat too low	Default output of battery temp block if not in monitor mode, direct path to disable charger loop Charging may continue in Cold zone if CHARGER_CTRL_REG[NTC_LOW_DISABLE] field is set. Otherwise, the Charger's FSM switches to the respective error state (TBAT_PROT), updating also the respective Error IRQ status register

The flags are debounced with 1 MHz clock.

When a timeout or overvoltage or a Vbus problem, the FSM goes to the ERROR state. At this point the charger is disabled, and an IRQ is generated. An interrupt status register contains information on which error occurred to trigger the IRQ.

7.2.6.3 Timers

There are four timers running on a base clock of 1 Hz:

1. Total charge time is up to 10.5 hours; for this reason, it is 16 bits.
2. Pre-charge time is up to 6 hours; for this reason, it is 15 bits.
3. CC mode charge time is up to 6 hours; for this reason, it is 15 bits.
4. CV mode charge time is up to 6 hours; for this reason, it is 15 bits.

Timers are cleared in EoC and when leaving DISABLED state.

7.2.7 Charger Detection

Device:	DA14691	DA14695	DA14697	DA14699
Feature Availability:	x	✓	✓	✓

The USB controller has built-in hardware to determine the charger type to which it is connected. Depending on the charger type, battery state and USB connection state, a defined current can be drawn from the charger. The main features of the charger detection circuit are listed below:

- Complies to "Battery Charging Specification" Revision V1.2 December 7, 2010 (BC1.2)
- Charger type detection: Dedicated Charging Port (DCP), Charging Downstream Port (CDP), Standard Downstream Port, PS2 port and Proprietary charger
- Dead battery provision
- Compatible with various smartphone chargers

The details of the charger detection circuit are shown in [Figure 21](#).

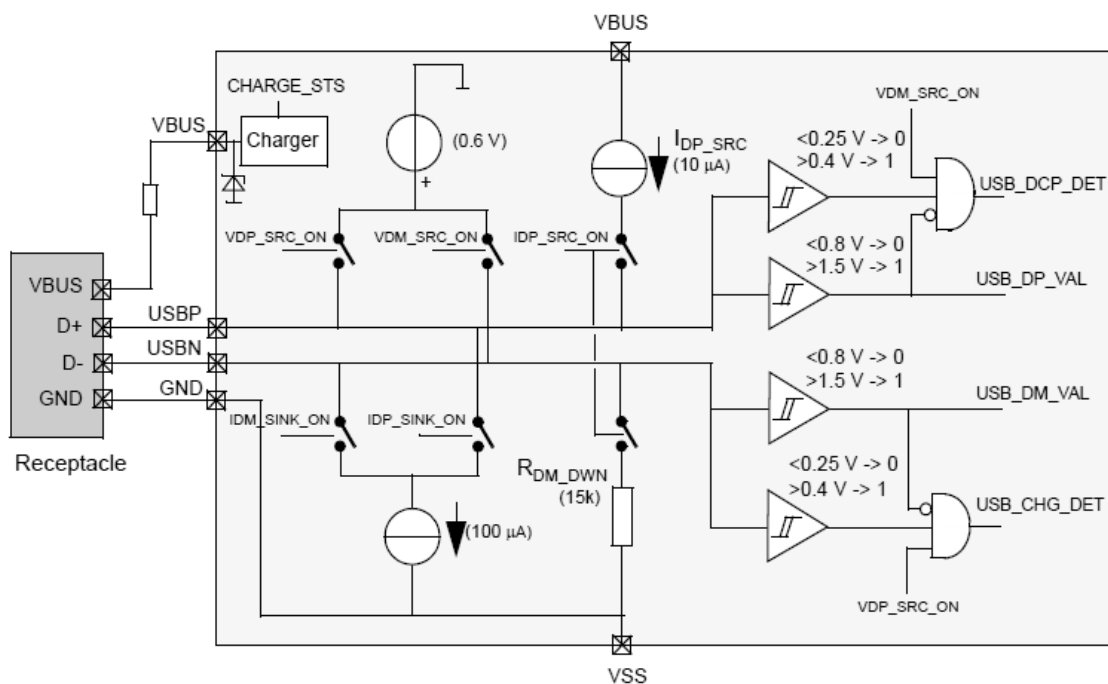

Figure 21. Charger detection circuit

The USB interface supports the battery charging with the following hardware blocks as shown in [Figure 21](#).

- A voltage source of 0.6 V can be switched to USBP or USBN with USB_CHARGER_CTRL_REG bits VDP_SRC_ON resp. VDM_SRC_ON
- A current sink of 100 µA can be switched to USBP or USBN with USB_CHARGER_CTRL_REG bits IDP_SINK_ON resp. IDM_SINK_ON. (internal logic prevents both switches from being enabled at the same time)
- A current source I_{DP_SRC} and R_{DM_DWN} can be enabled with USB_CHARGER_CTRL_REG[IDP_SRC_ON]
- A logic level Schmitt trigger is used for USBN, USBP read in USB_CHARGER_STAT_REG bits USB_DM_VAL, resp. USB_DP_VAL logic level (0: <0.8 V 1: >2 V)
- A comparator output CHG_DET read in USB_CHARGER_STAT_REG[USB_CHG_DET] to detect a level of 0.4 V < USBN < 1.5 V to indicate that a DCP or CDP is connected
- A comparator output DCP_DET read in USB_CHARGER_STAT_REG[USB_DCP_DET] to detect a level of 0.4 V < USBP < 1.5 V to indicate that a DCP is connected

Initially all bits of USB_CHARGER_CTRL_REG must be set to reset value 0.

The presence of VBUS can be checked by reading bit BAT_STATUS_REG[VBUS_AVAILABLE].

The charger detection hardware can operate in polling mode or can generate a USB interrupt to the Cortex-M33. A change in one of the bits [3:0] of register USB_CHARGER_STAT_REG, sets bits USB_MAEV_REG[USB_CH_EV] if the corresponding bits [7:4] are set to 1. If USB_CHARGER_STAT_REG is read, bit USB_CH_EV interrupt is cleared. The interrupt "set" conditions have priority over the "clear" condition of the read access.

7.2.7.1 Contact Detection

If USB_CHARGER_CTRL_REG[IDP_SRC_ON] is set, bit USB_CHARGER_STAT_REG[USB_DP_VAL] indicates that the data pins make contact (see Table 77). It is the responsibility of the software to wait until the USBN and USBP contact bouncing finished before the register is read.

Table 77: USBP, USBN contact detection

Port	USBP	USBN	USB_DP_VAL
Nothing connected	>1.5 V	0	1
Standard downstream	<0.8 V	0	0
Dedicated charger	<0.8 V	<0.8 V	0
Charging downstream	<0.8 V	<0.8 V	0

7.2.7.2 Primary Charger Detection

Primary charger detection is used to detect whether the downstream port has charging capabilities or not. The detection is initiated by setting bits USB_CHARGER_CTRL_REG[VDP_SRC_ON] and USB_CHARGER_CTRL_REG[IDM_SINK_ON]. This enables the voltage source VDP_SRC on USBP and the current source IDM_SINK on USBN. The measured levels on USBP and USBN shown in Table 78 determine the value of bit USB_CHARGER_STAT_REG[USB_CHG_DET].

Table 78: Charger Type Detection

Port	USBP	USBN	USB_CHG_DET
Dedicated charger	0.6 V	>0.4 V && <1.5 V	1
Charging downstream	0.6 V	First <0.25 V then 0.6 V	0 then 1 after 1 ms – 20 ms
Standard downstream	0.6 V	<0.25 V	0
PS2	2 V	2 V	0

When the charger detection is done before the charging downstream port is enabled its V_{DM_SRC} (so before 20 ms) a standard downstream port is detected, which is safe but incorrect. After the V_{DM_SRC} has been enabled in the charging downstream port, a charger port is detected.

7.2.7.3 Secondary Charger Detection

Secondary charger detection can be used to distinguish a dedicated charger or a charging downstream port. The detection is initiated by setting bits USB_CHARGER_CTRL_REG[VDM_SRC_ON] and USB_CHARGER_CTRL_REG[IDP_SINK_ON]. This enables V_{DM_SRC} and I_{DP_SINK}. The difference between a DCP and a CDP is shown Table 79.

Table 79: Secondary charger detection

Port	USBP	USBN	USB_DCP_DET
dedicated charger	>0.4 V <1.5 V	0.6 V	1
charging downstream	<0.25 V	0.6 V	0

7.2.7.4 Smartphone Charger Detection

The battery charger detection circuit can detect smartphone chargers with characteristics shown in Table 80.

Table 80: Smartphone charger characteristics

USBP	USBN	Load Current
2.0 V	2.0 V	Up to 500 mA

USBP	USBN	Load Current
2.0 V	2.8 V	Up to 1 A
2.8 V	2.0 V	Up to 2 A
2.8 V	2.8 V	Up to 2.4 A

The smartphone charger circuit can be enabled by the USB_CHARGE_ON bit of the USB_CHARGER_CTRL_REG register. The results of the detection are available on the USB_CHARGER_STAT_REG register.

7.2.8 Rails Discharge

The power rails have a software-controlled discharge capability which practically uses multiple NMOS transistors to rapidly discharge the external decoupling capacitors. This feature enables power cycling of the external components when system is resetting.

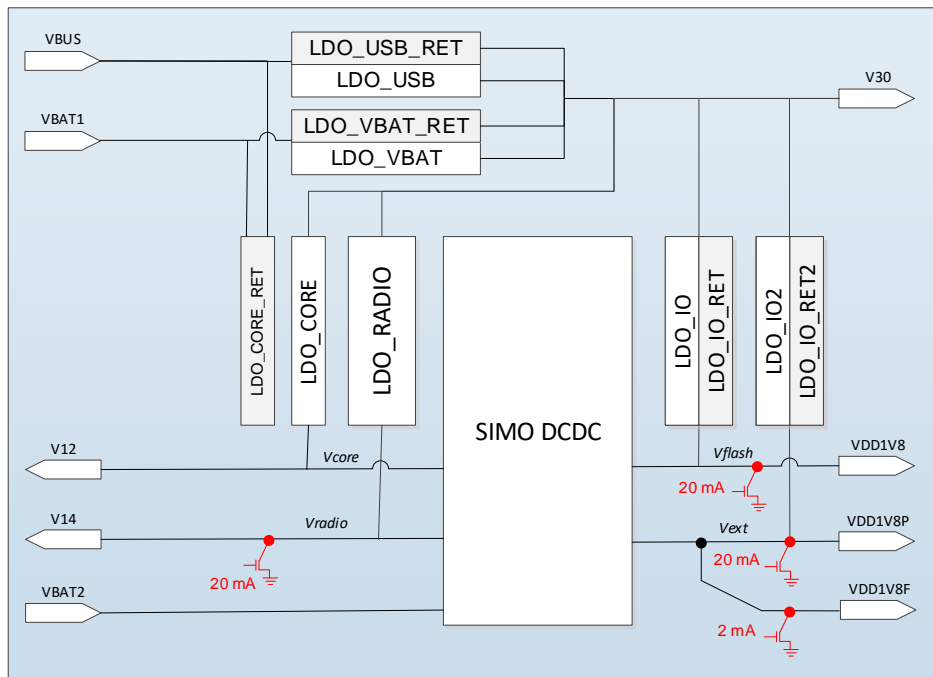

Figure 22. Power rail discharging feature

There is a hardwired configuration for the allowed discharging current of each rail which is either 2, or 20 mA. Figure 22 shows the configuration for the discharging elements.

Triggering of the discharging process can only happen with use of software writing to DISCHARGE_RAIL_REG.

8. Power Domain Controller (PDC)

Device:	DA14691	DA14695	DA14697	DA14699
Feature Availability:	✓	✓	✓	✓

8.1 Introduction

The Power Domain Controller (PDC) is responsible for acting after waking up or before going to sleep regarding the activation/de-activation of the seven digital power domains of the system. It follows the hardware FSM for start-up/wake-up and it precedes the go-to-sleep hardware FSM described in Section 6.3.4. It is a digital hardware state machine that defines the following parameters after consulting a programmable look-up table (LUT):

- Which power domain to activate after a wake-up trigger
- If XTAL32M needs to be started after a wake-up trigger
- If the system can go to deep sleep (trigger the hardware FSM to disable DCDC, Bandgap and LDOs)

The PDC can be triggered by any GPIO, general purpose timers, RTC, the MAC timer, the Motor Controller, VBUS or SWD presence, or even by Software a trigger issued by one of the three masters of the system (Cortex-M33, CMAC or SNC).

Features

- 16 places of 13-bit words Look-Up Table (LUT) for defining what the system should do upon any wake-up trigger
- Triggers from IOs, internal timers/controllers, or software
- Triggers from internal diagnostic signals
- Monitors if a power domain is actively used by any master before shutting it down
- Allows system to go to deep sleep if all masters' domains are off
- System wake-up can be overridden by accessing the PMU_CTRL_REG

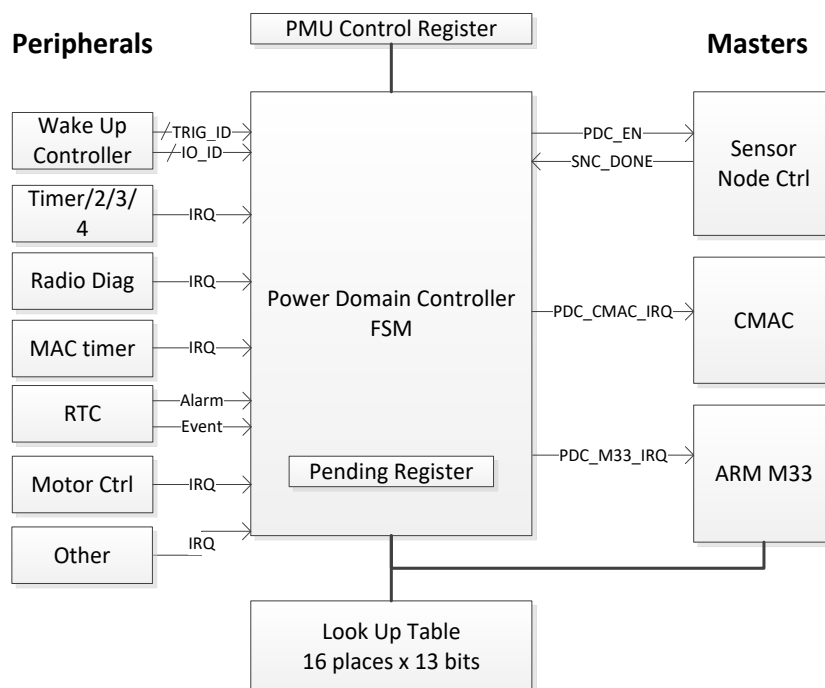

Figure 23. Power

8.2 Architecture

8.2.1 Look-Up Table

The Look-Up Table (LUT) is initialized at cold boot by the Cortex-M33. It is instructing the PDC which digital power domains to activate based on the triggering source.

The format of the LUT is presented in [Table 81](#).

Table 81: PDC LUT format

	Bit	Function		
Triggers	0	if 0x00 then P0 GPIO	if 0x01 then P1 GPIO	if 0x02 or 0x3 then Peripheral
	1			
	2	Pin_ID	Pin_ID	Periph_ID
	3	Pin_ID	Pin_ID	Periph_ID
	4	Pin_ID	Pin_ID	Periph_ID
	5	Pin_ID	Pin_ID	Periph_ID
	6	Pin_ID	Pin_ID	
Action	7	Enable XTAL32M		
	8	Enable PD_TMR		
	9	Enable PD_PER		
	10	Enable PD_COM (Needed for using the GPIOs)		
	11	Wake up Master_ID		
	12	Wake up Master_ID		

A look up table of 13 bits width describes what happens on each trigger. The depth of the LUT is 16 places, i.e. the system supports up to 16 different configurations given a specific trigger for waking up, but this could be changed dynamically by application software if needed.

There are three different trigger types that will be evaluated when a trigger comes according to the value bits 0 and 1 of each LUT entry:

- If Bits[1:0]=0x0 then it is a GPIO toggle from P0. Bits [6:2] contain the pin number that has triggered
- If Bits[1:0]=0x1 then it is a GPIO toggle from P1. Bits [6:2] contain the pin number that has triggered
- If Bits[1:0]=0x2 or 0x3 then it is a trigger from some peripheral. Bits [5:2] define the peripheral according to [Table 82](#)

Table 82: Peripheral trigger encoding

ID	Peripheral
0	Timer
1	Timer2
2	Timer3
3	Timer4
4	RTC Alarm/Rollover
5	RTC Timer
6	MAC Timer
7	Motor Controller
8	XTAL32MDRY_IRQ
9	RFDIAG_IRQ
10	VBUS_IRQ or

ID	Peripheral
	Debounced IO IRQ or JTAG_IRQ or CMAC2SYS_IRQ
11	Sensor Node Controller IRQ
12-14	Reserved
15	Software Trigger

Bits[12:7] explain what needs to be done after a trigger from the triggering sources as explained so far. More specifically, a triggering source might request to:

- Enable the XTAL32M. This bit is set if clock precision is required by the application. The PDC state machine will only enable the XTAL32MHz block but switching the system clock to the XTAL32M will not be done. This has to be done by software. Since multiple masters might want to switch to XTAL32, switching to this clock can be done by any master but switching back should not be allowed. Turning off the XTAL32M is done automatically when the system enters deep sleep (for example, the PDC allows the HW FSM to turn off all LDOs and Bandgap)
- Enable PD_TMR or PD_PER. These digital power domains are the only ones that do not contain a master. PD_MEM is always enabled since all masters are using this power domain
- Enable PD_COM. Although this power domain is controlled by its own master (SNC), it might be requested by others because this power domain contains the GPIO mode configuration. To use GPIOs, the PD_COM must be activated
- Issue a wake-up IRQ/Signal to any other master. Hence a master can wake up another master with use of a LUT entry. The Master ID is encoded as follows.

Table 83: Master trigger encoding

ID	Master
0x0	Reserved
0x1	Cortex-M33
0x2	CMAC
0x3	Sensor Node Controller (SNC)

8.2.2 Operation

The PDC re-evaluates all available information every time there is a trigger input. It does the same every time there is feedback from one of the three masters indicating that they have finished what they were triggered to do. The latter is implemented using signaling between the masters and the PDC, namely:

- A deep sleep signal coming from Cortex-M33 or CMAC which is asserted when the Cortex-M33 SCR bit is set and the WFI command executed
- A done signal coming from SNC which is asserted when the SLP command is executed

Every time a trigger occurs, the PDC follows the action plan as programmed in the LUT. It also asserts the respective bit number in the PENDING register that keeps one bit per LUT entry (for example, if LUT entry #2 was triggered, PENDING[2] is also asserted). The master that is woken up, acknowledges the PENDING bit and after finishing its tasks, it notifies the PDC that any request for power domains activation is not valid anymore. The PDC cross-checks the complete LUT to see if there is any other active entry that still uses any of the power domains requested. If not, these power domains are shut down. If other masters still use one of the domains, then it does not allow this domain to be powered down.

The PENDING register should be acknowledged as soon as possible and well before issuing a SLP/WFI command.

If there is no active LUT entry where one of the three masters is still up and running, then the PDC allows the system to go to deep sleep (that is invokes the hardware FSM and turns off bandgap and LDOs) . Any power domain will be allowed to turn off, depending on the value of the respective field in the PMU_CTRL_REG. Hence, if for example, PMU_CTRL_REG[RADIO_SLEEP] = 1 then given the fact that no LUT entry is active, the power domain is turned off.

8.3 Programming

There is a simple sequence of steps that needs to be followed to program and use the Power Domain controller:

5. Add a PDC entry by writing the PDC_CTRLx_REG:
 - a. Select Trigger (TRIG_SELECT):
 - i. 0: Trigger is a GPIO on Port 0 (selectable through Wake-Up Controller).
 - ii. 1: Trigger is a GPIO on Port 1 (selectable through Wake-Up Controller).
 - iii. 2: Trigger is a Peripheral IRQ (see register description).
 - iv. 3: Trigger is another Master (see register description).
 - b. Select Trigger ID (TRIG_ID):
Valid when TRIG_SELECT = 0x0, 0x1 or 0x2 (see register description for options).
 - c. Enable extra options if needed (EN_COM, EN_PER, EN_TMR, EN_XTAL).
 - d. Select the master to wake up (PDC_MASTER):
 - i. 0: PDC entry is disabled.
 - ii. 1: Wake up Arm Cortex-M33.
 - iii. 2: Wake up CMAC.
 - iv. 3: Wake up Sensor Node Controller.
6. Check if a PDC entry has been triggered (PDC_PENDING_REG).
7. If needed, trigger a PDC by SW (PDC_SET_PENDING_REG).
8. Clear any pending requests and/or IRQs (PDC_ACKNOWLEDGE_REG).

9. Brown-Out Detector

Device	DA14691	DA14695	DA14697	DA14699
Feature Availability	✓	✓	✓	✓

9.1 Introduction

The brown-out detector (BOD) is a voltage monitoring circuit that triggers a hardware reset if LDOs or supply voltages go below a certain threshold.

The BOD is active in either ACTIVE, SLEEP, or DEEP_SLEEP mode with periodically a programmable interval (PMU_SLEEP_REG[BOD_SLEEP_INTERVAL]).

While in DEEP_SLEEP mode, the detector is regularly activated for a voltage comparison of the supply sources after which it goes in DEEP_SLEEP mode again. The amount of time BOD is active is one low power clock period.

Features

- Independent voltage monitoring of seven power rails
- Programmable BOD levels
- Periodic detection mechanism, available during active and sleep periods

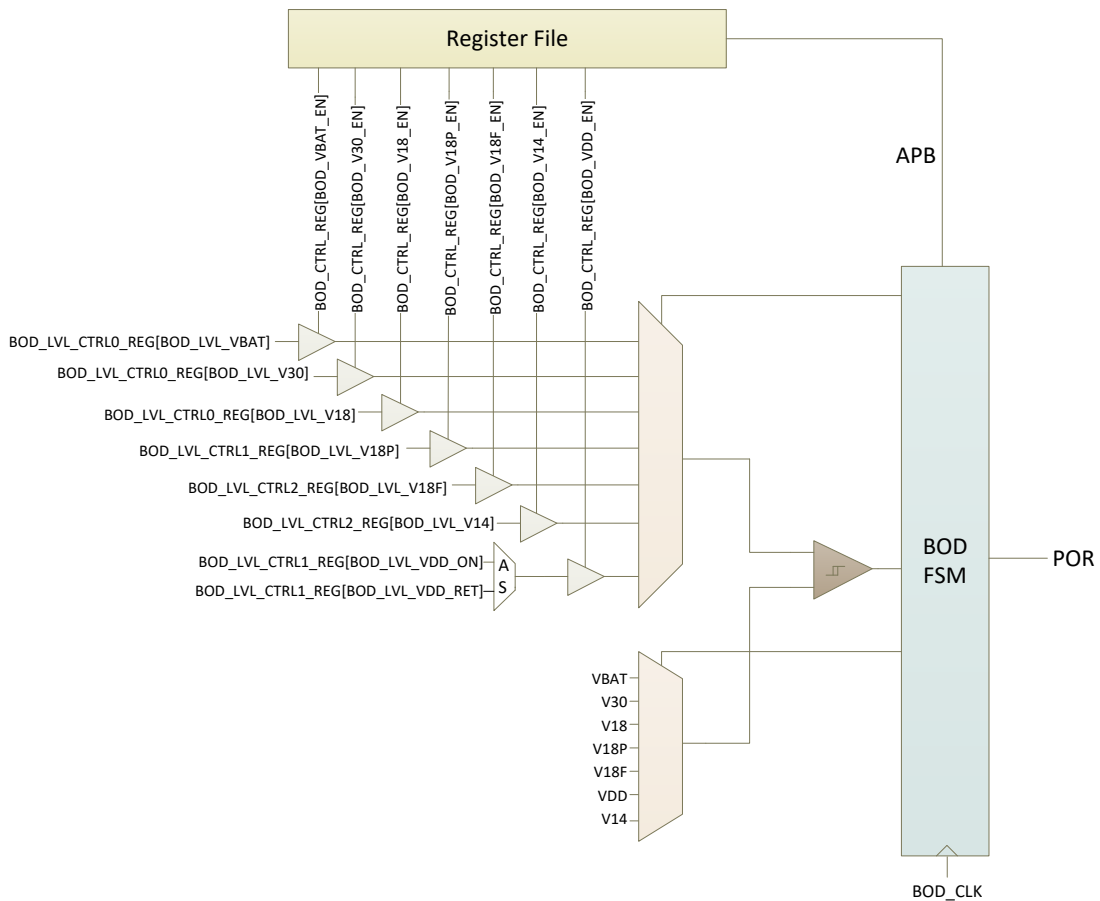

Figure 24. Brown-out detector block diagram

9.2 Architecture

9.2.1 Brown-Out Detector Monitor Levels

Although the voltage levels are programmable, their reset levels have a value matching their default operating value. The comparator levels are programmable according to formula:

$$\text{BOD_LVL_CTRLx_REG [BOD_LVL_Vxx]} = 1.2 * (\text{BOD_LVL} + 1)/192$$

For VBAT, a 1.5x scaler is enabled:

$$\text{BOD_LVL_CTRL0_REG [BOD_LVL_VBAT]} = 1.5 * (1.2 * (\text{BOD_LVL} + 1)/192)$$

Table 84 shows the comparator registers and their default levels (Vth_bod) below which, a reset is triggered.

Table 84: Brown-out detectors and default levels

BOD_LVL_CTRLx_REG	Default level (V)	Default level (Hex)
VBAT	2.475	0xAF
V30	1.65	0x107
V18	1.65	0x107
V18P	1.65	0x107
V18F	1.65	0x107
V14	1.25	0xC7
VDD (Active)	1.05	0xA7
VDD (Sleep)	0.7	0x6F

All individual brown-out detectors are disabled at startup. To enable them, set the corresponding bit in BOD_CTRL_REG[BOD_Vxx_EN].

The BOD levels are checked in a sequential way. The more detectors are enabled, the slower the detection rate is.

Figure 25 shows The BOD FSM timing, checking up to 7 channels.

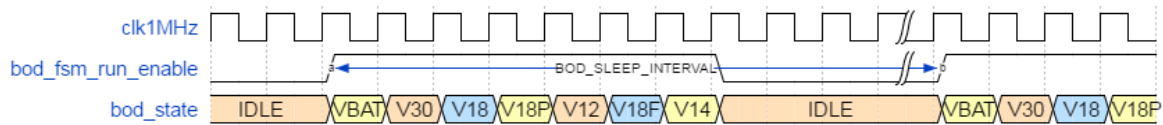

Figure 25. BOD FSM timing diagram in Sleep mode

9.2.2 Brown-Out Detector Clock

The clock of the BOD FSM is 8 MHz in active and 1 MHz in sleep cases. The BOD_SLEEP_INTERVAL is counting down LP_CLK clocks while in Sleep mode. The BOD clock can further be reduced using BOD_CTRL_REG[BOD_CLK_DIV]. A slower clock period, however, reduces the detection of small voltage drops and spikes.

9.3 Programming

There is a simple sequence of steps that needs to be followed to configure the Brown-Out Detector:

1. Set up the interval when Brown Out Detection is activated to check on the power rails voltage (PMU_SLEEP_REG[BOD_SLEEP_INTERVAL]).
2. Configure the BOD voltage levels for the chosen power rails (BOD_LVL_CTRLx_REG).
3. Enable the BOD monitoring for the chosen power rails (BOD_CTRL_REG[BOD_xxxx_EN]).

10. Reset

Device:	DA14691	DA14695	DA14697	DA14699
Feature Availability:	✓	✓	✓	✓

10.1 Introduction

The DA1469x has a RSTN pad which is active low. It contains a RC filter for spikes suppression with 400 k Ω resistor and a 2.8 pF capacitor. It also includes a 25 k Ω pull-up resistor. This pad should be driven externally using a FET or a single button connected to Ground. The typical latency of the RSTN pad is about 2 μ s.

Additionally, a configurable Power-on Reset circuitry is included, to allow for a programmable time delayed POR functionality from a configurable reset source. By default, this circuitry is connected to the RSTN pin, but software can remap it to any GPIO.

A software reset is available. This is done by either programming a specific register or triggering it via the debugger interface.

Features

- RC spike filter on RSTN to suppress external spikes (400 k Ω , 2.8 pF)
- Three different reset lines (software, hardware and POR)
- Reset cause is latched in a specific register
- Configurable POR circuitry

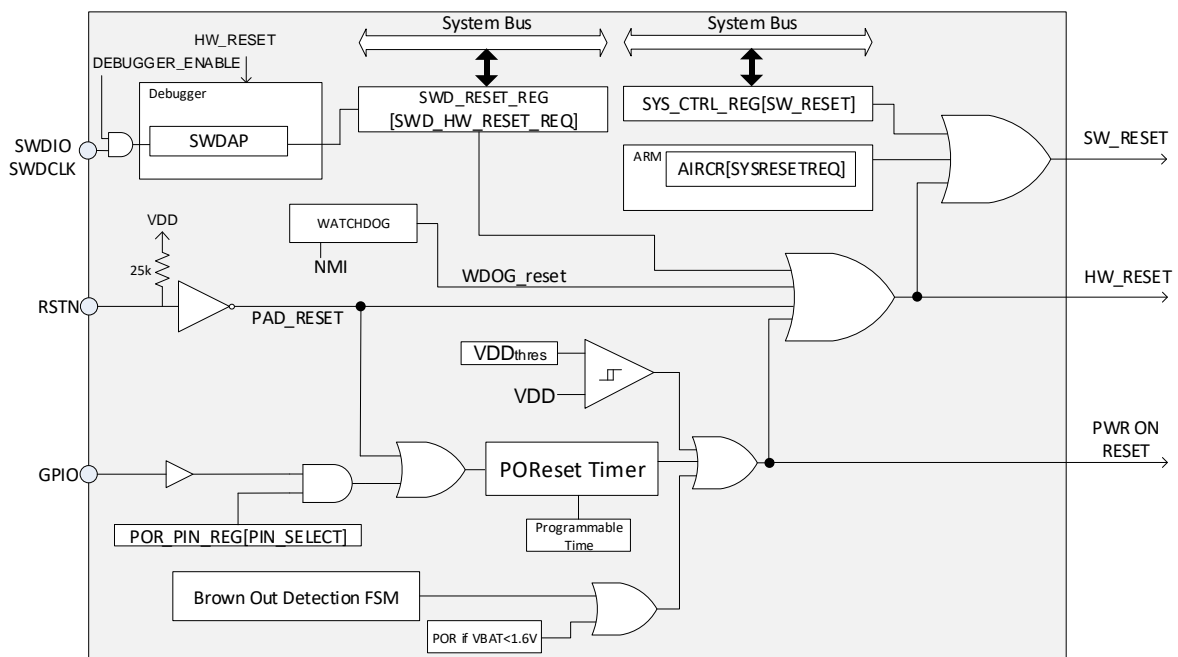

Figure 26. Reset block diagram

There are three main reset signals in the DA1469x:

- The PWR ON reset, triggered by a GPIO set as POR source with selectable polarity and/or the RSTN pad, after a programmable time delay
- The hardware reset, triggered by the RSTN pad when it becomes active for a short period of time (less than the programmable delay for POR)
- The software reset, triggered by writing the SYS_CTRL_REG[SW_RESET] bit or Arm's AIRCR[SYSRESETREQ] register

10.2 Architecture

The Power-on Reset (POR) signal is generated as follows:

- Internally, it releases the system's flip flops as soon as the VDD voltage crosses the minimum threshold value
- Brown-Out Detection FSM senses the various internal voltage levels to be higher than the programmed thresholds
- Externally by a Power-on Reset source (RSTN pad or GPIO)

The hardware reset can be automatically triggered at system wake-up from the Extended or Deep Sleep mode, by programming bit PMU_CTRL_REG[RESET_ON_WAKEUP]. The PWR ON reset and the hardware reset runs the cold start-up sequence and the BootROM code is executed.

The software reset is the logical OR of a signal from the Arm CPU (triggered by writing SCB->AIRCR = 0x05FA0004), and the SYS_CTRL_REG[SW_RESET] bit. This is mainly used to reboot the system after the base address is remapped.

Certain registers are reset by Power-on Reset only. These registers are listed in [Table 85](#).

Table 85: Reset Signals and Registers

Reset source	Registers
POR reset	SYS_STAT_REG CLK_XTAL32K_REG CLK_RTCDIV_REG BANDGAP_REG POR_VBAT_CTRL_REG POR_PIN_REG POR_TIMER_REG RESET_STAT_REG[PORESET_STAT] RTC_CONTROL_REG RTC_KEEP_RTC_REG
Hardware reset	BOD_CTRL_REG BOD_LVL_CTRL0_REG BOD_LVL_CTRL1_REG BOD_LVL_CTRL2_REG CACHE ASSOCCFG_REG CACHE_CTRL1_REG CACHE_CTRL2_REG CACHE_FLASH_REG CACHE_LNSIZECFG_REG CLK_AMBA_REG CLK_CTRL_REG CLK_FREQ_TRIM_REG CLK_RADIO_REG CLK_RC32K_REG CLK_RC32M_REG CLK_RCX_REG DCDC_CTRL1_REG DCDC_CTRL2_REG DCDC_IRQ_CLEAR_REG DCDC_IRQ_MASK_REG DCDC_IRQ_STATUS_REG DCDC_STATUS1_REG DCDC_STATUS2_REG DCDC_STATUS3_REG DCDC_STATUS4_REG DCDC_TEST_REG DCDC_V14_REG DCDC_V18_REG DCDC_V18P_REG DCDC_VDD_REG DEBUG_REG

Reset source	Registers
	LDO_VDDD_HIGH_CTRL_REG OTPC_MODE_REG OTPC_PADDR_REG OTPC_PWORD_REG OTPC_STAT_REG OTPC_TIM1_REG OTPC_TIM2_REG P0_PAD_LATCH_REG P0_RESET_PAD_LATCH_REG P0_SET_PAD_LATCH_REG P1_PAD_LATCH_REG P1_RESET_PAD_LATCH_REG P1_SET_PAD_LATCH_REG PDC_ACKNOWLEDGE_REG PDC_CTRL0_REG PDC_CTRL1_REG PDC_CTRL10_REG PDC_CTRL11_REG PDC_CTRL12_REG PDC_CTRL13_REG PDC_CTRL14_REG PDC_CTRL15_REG PDC_CTRL2_REG PDC_CTRL3_REG PDC_CTRL4_REG PDC_CTRL5_REG PDC_CTRL6_REG PDC_CTRL7_REG PDC_CTRL8_REG PDC_CTRL9_REG PDC_PENDING_CM33_REG PDC_PENDING_CMAC_REG PDC_PENDING_REG PDC_PENDING_SNC_REG PDC_SET_PENDING_REG PLL_SYS_CTRL1_REG PLL_SYS_CTRL2_REG PLL_SYS_STATUS_REG PMU_CTRL_REG PMU_SLEEP_REG PMU_TRIM_REG POWER_CTRL_REG QSPIC_BURSTBRK_REG QSPIC_BURSTCMDA_REG QSPIC_BURSTCMDB_REG QSPIC_CHKERASE_REG QSPIC_CTR_CTRL_REG QSPIC_CTR_EADDR_REG QSPIC_CTR_KEY_0_3_REG QSPIC_CTR_KEY_12_15_REG QSPIC_CTR_KEY_16_19_REG QSPIC_CTR_KEY_20_23_REG QSPIC_CTR_KEY_24_27_REG QSPIC_CTR_KEY_28_31_REG QSPIC_CTR_KEY_4_7_REG QSPIC_CTR_KEY_8_11_REG QSPIC_CTR_NONCE_0_3_REG QSPIC_CTR_NONCE_4_7_REG QSPIC_CTR_SADDR_REG QSPIC_CTRLBUS_REG QSPIC_CTRLMODE_REG

Reset source	Registers
	QSPIC_DUMMYDATA_REG QSPIC_ERASECMDA_REG QSPIC_ERASECMDDB_REG QSPIC_ERASECTRL_REG QSPIC_GP_REG QSPIC_READDATA_REG QSPIC_RECVDATA_REG QSPIC_STATUS_REG QSPIC_STATUSCMD_REG QSPIC_WRITEDATA_REG QSPIC2_AWRITECMD_REG QSPIC2_BURSTBRK_REG QSPIC2_BURSTCMDA_REG QSPIC2_BURSTCMDDB_REG QSPIC2_CHKKERASE_REG QSPIC2_CTRLBUS_REG QSPIC2_CTRLMODE_REG QSPIC2_DUMMYDATA_REG QSPIC2_ERASECMDA_REG QSPIC2_ERASECMDDB_REG QSPIC2_ERASECTRL_REG QSPIC2_MEMBLN_REG QSPIC2_READDATA_REG QSPIC2_RECVDATA_REG QSPIC2_STATUS_REG QSPIC2_STATUSCMD_REG QSPIC2_WRITEDATA_REG RAM_PWR_CTRL_REG RESET_STAT_REG SECURE_BOOT_REG SWD_RESET_REG SYS_CTRL_REG TRIM_CTRL_REG USB_RXC2_REG WATCHDOG_CTRL_REG WATCHDOG_REG
Watchdog reset	RESET_STAT_REG[CMAC_WDOGRESET_STAT] RESET_STAT_REG[WDOGRESET_STAT]
Software reset	The rest of the Register File

10.2.1 Power-On Reset from Pin

The Power-on Reset function can be triggered at timer expiration. It is available at two sources:

- Reset Pad (RSTN): Reset pad is always capable of producing a Power-on Reset
- GPIO Pin: A GPIO can be selected by the user application to act as POR source

The POR_TIMER_REG configures the time needed for the POReset signal to be active. by. The register field POR_TIME is a 7-bits field (maximum value is 0x7F), which holds a multiplication factor for counting RC32K clock periods. This is explained in the following formula:

Total time for POR = POR_TIME x 4096 x RC32k clock period,

where RC32k clock period = 31.25 μs at 25 °C.

The maximum time for issuing a POR is ~16.2 seconds at 25 °C, while the default value is ~3 seconds (POR_TIME=0x18).

The RC32k clock is temperature dependent so based on the temperature span of -10 °C to 50 °C, clock frequency range is calculated to be 23 kHz to 37 kHz. Then the min and max POR times can be calculated as indicated in POR_TIMER_REG description.

The Power-on Reset timer is clocked by the RC32k clock. If the application disables the RC32k, then hardware takes care of re-enabling the RC32k clock. Note that, if POR is generated from the Reset pad, RC32k operate with the default (reset) trim value. If a GPIO is used as a POR source, the RC32 clock is trimmed. The timing deviation between both cases is expected to be minor.

The same clock source (RC32k) is used as an input to the watchdog timer. Even if the application has accidentally disabled the clock, we start the hardware again and the watchdog still runs.

When a GPIO is used as a Power-on Reset source, the selected pin retains its capability to act as GPIO. The POR_PIN_REG[PIN_SELECT] field holds the required GPIO pin number. If the value of the PIN_SELECT field equals to 0 the POR over GPIO functionality is disabled. The polarity of the pin can be configured by the POR_PIN_REG [POR_POLARITY] bit where 0 means Active Low and 1 Active High.

The operation of the Power-on Reset for both Reset pad and GPIO is depicted in [Figure 27](#).

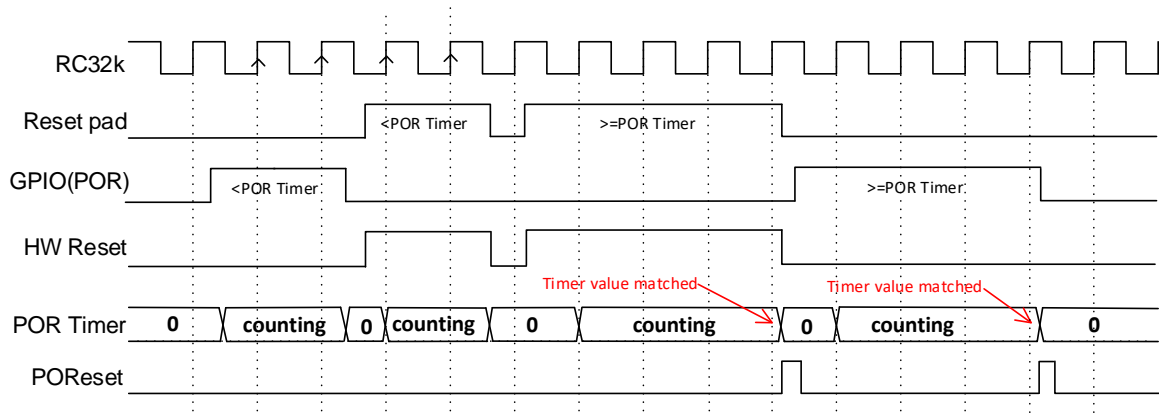

Figure 27. Power-on reset timing diagram

If any of the POR sources is asserted, then the POR timer starts to count. When a POR source is released before the timer has expired, POR timer resets to 0. If a second source is asserted while the first is already asserted and the first is released after that point, POR occurs, if the total time of both sources kept asserted is larger or equal than the POR_TIME.

The POR_PIN_REG[PIN_SELECT] field cannot survive any Reset (POR, hardware, software) hence the user must take special care on setting up the GPIO POR source right after a reset. This also applies for the POR_TIMER_REG[POR_TIME] field after a Power-on Reset.

You should consider that if a GPIO is used as POR source, the dynamic current of the system increases, due to the dynamic current consumed by the RC32k oscillator. This increase is calculated to be ~100 nA and it is also present during sleep time period. POR from Reset pin does not add this dynamic current consumption.

10.3 Programming

There is a simple sequence of steps that needs to be followed to configure the POR from GPIO functionality:

1. Select the GPIO to be set as POR source (POR_PIN_REG[POR_PIN_SELECT]).
2. Set up the input polarity of the GPIO that causes POR (POR_PIN_REG[POR_PIN_POLARITY]).
3. Configure the time for the POR to happen (POR_TIMER_REG[POR_TIME]). Default time is ~3 s.

Remember that to set up the time that the Reset pin produces a POR, only POR_TIMER_REG must be set.

11. Arm® Cortex®-M3

Device:	DA14691	DA14695	DA14697	DA14699
Feature Availability:	✓	✓	✓	✓

11.1 Introduction

The Cortex®-M3 processor is a low gate count, highly energy efficient processor that is intended for microcontroller and deeply embedded applications. The processor is based on the Armv8-M architecture and is primarily for use in environments where security is an important consideration. The interfaces that the processor supports include:

- Code AHB (C-AHB) interface
- System AHB (S-AHB) interface
- External PPB (EPPB) APB interface
- Debug AHB (D-AHB) interface

Arm® Cortex®-M3 does not retain its status when going to any sleep modes that switch off its power domain. So, the CPU always wakes up in reset. Restoration of the CPU state is done by software.

Features

- Supports the Armv8-M Main Extension. The processor has optional support for one or more of the following extensions:
 - The Floating-point Extension
 - The Digital Signal Processing (DSP) Extension
 - The Debug Extension
- An in-order issue pipeline
- Thumb-2 technology
- Configurable to perform data accesses as either big or little endian
- Nested Vectored Interrupt Controller (NVIC)
- Floating Point Unit (FPU) supporting single-precision arithmetic
 - Combined multiply-add instructions for increased precision (Fused MAC)
 - Hardware support for conversion, addition, subtraction, multiplication with optional accumulate, division, and square-root
 - Hardware support for denormals and all IEEE Standard 754-2008 rounding modes
 - 32 32-bit single-precision registers or 16 64-bit double-precision registers
 - Lazy floating-point context save
- Support for exception-continuable instructions
- Micro Trace Buffer (MTB)

11.2 Architecture

11.2.1 Interrupts

This section lists all 40 interrupt lines, except the NMI interrupt, and describes their source and functionality. The overview of the interrupts is illustrated in [Table 86](#).

Table 86: Interrupt list

#	Name	Type	Polarity	Description
0	SNC_IRQ	Level	Active High	Sensor Node Controller interrupt line
1	DMA_IRQ	Pulse	Active High	General Purpose DMA interrupt line
2	CHARGER_STATE_IRQ	Pulse	Active High	Serves both the Charger FSM as well as the JEITA FSM

Multi-Core Bluetooth 5.2 SoC Family with System PMU

#	Name	Type	Polarity	Description
3	CHARGER_ERROR_IRQ	Pulse	Active High	Charger error interrupt line
4	CMAC2SYS_IRQ	Level	Active High	CMAC and mailbox interrupt line
5	UART_IRQ	Level	Active High	UART interrupt line
6	UART2_IRQ	Level	Active High	UART2 interrupt line
7	UART3_IRQ	Level	Active High	UART3 interrupt line
8	I2C_IRQ	Level	Active High	I2C interrupt line
9	I2C2_IRQ	Level	Active High	I2C2 interrupt line
10	SPI_IRQ	Level	Active High	SPI interrupt line
11	SPI2_IRQ	Level	Active High	SPI2 interrupt line
12	PCM_IRQ	Pulse	Active High	PCM interrupt line
13	SRC_IN_IRQ	Level/Pulse	Active High	SRC input interrupt line. Level if FIFO is enabled
14	SRC_OUT_IRQ	Level/Pulse	Active High	SRC output interrupt line. Level if FIFO is enabled
15	USB_IRQ	Level	Active High	USB interrupt line
16	TIMER_IRQ	Level	Active High	TIMER interrupt line
17	TIMER2_IRQ	Level	Active High	TIMER2 interrupt line
18	RTC_IRQ	Level	Active High	RTC interrupt line
19	KEY_WKUP_GPIO_IRQ	Level	Active High	Debounced button press interrupt. This interrupt is first driven to the PDC and then directed to the required masters to be waken up/notified
20	PDC_M33_IRQ	Level	Active High	This is an interrupt coming from the PDC indicating that the Cortex-M33 needs to be waken up due to a GPIO/Peripheral/other master request
21	VBUS_IRQ	Level	Active High	VBUS presence interrupt
22	MRM_IRQ	Pulse	Active High	Cache miss rate monitor interrupt
23	MOTOR_CONTROLLER_IRQ	Level	Active High	MOTOR controller interrupt line
24	TRNG_IRQ	Pulse	Active High	True Random Number Generation interrupt.
25	DCDC_IRQ	Pulse	Active High	DCDC interrupt. Generated upon time out threshold reach
26	XTAL32MDRY_IRQ	Pulse	Active High	Indicates that XTAL32M oscillator is trimmed and settled and can provide a reliable 32 MHz clock
27	GPADC_IRQ	Level	Active High	General Purpose analog-digital converter interrupt
28	SDADC_IRQ	Level	Active High	Sigma-Delta analog-digital converter interrupt
29	CRYPTO_IRQ	Level	Active High	Crypto interrupt. Sources: AES or HASH function interrupt
30	CAPTIMER1_IRQ	Pulse	Active High	GPIO triggered Timer1 Capture interrupt
31	RFDIAG_IRQ	Pulse	Active High	Baseband or Radio Diagnostics Interrupt
32	LCD_CONTROLLER_IRQ	Pulse	Active High	Parallel LCD Controller interrupt line
33	PLL_LOCK_IRQ	Level	Active High	Indicates that DLL/PLL is locked at 96 MHz
34	TIMER3_IRQ	Level	Active High	TIMER3 interrupt line
35	TIMER4_IRQ	Level	Active High	TIMER4 interrupt line
36	LRA_IRQ	Pulse	Active High	LRA/ERM interrupt line
37	RTC_EVENT	Level	Active High	RTC event interrupt line
38	GPIO_P0_IRQ	Level	Active High	GPIO port 0 toggle interrupt line

#	Name	Type	Polarity	Description
39	GPIO_P1_IRQ	Level	Active High	GPIO port 1 toggle interrupt line

11.2.2 Reference

The register descriptions for the Nested Vectored Interrupt Controller (NVIC), the System Control Block (SCB) and the System Timer (SysTick) of the Arm Cortex-M33 can be found in the following documents, available on the Arm website:

Devices Generic User Guide:

<https://developer.arm.com/docs/100235/latest/preface>

Technical Reference Manual:

<https://developer.arm.com/docs/100230/0004>

12. Cache Controller

Device:	DA14691	DA14695	DA14697	DA14699
Feature Availability:	✓	✓	✓	✓

12.1 Introduction

The cache controller is used to accelerate the system performance of the Arm Cortex-M33 executing from QSPI FLASH. It also conserves power by reducing the access of the external QSPI FLASH. The cache dynamically loads program and data code into the cache Data RAM and executes from there.

The cache controller is controlled via the CACHE_*_REGs. The cache administration is kept in TAG memory. This memory can be invalidated by asserting the FLUSH bit in the CACHE_CTRL1_REG. The Arm Cortex-M0+ is halted during such an invalidation; it resumes automatically. N-way associative replacement strategy is based on the value of a pseudo random LFSR.

The cache controller does not support a runtime configuration of cache line size and associativity. The selection of the configurations depends on the code type and application; it is determined empirically.

For debugging, the Data and TAG memory can be monitored on the AHB-SYS bus (See memory map). The cache is used for dynamic code and data caching. As an alternative for fast code executions, the data-RAM can be used for static code storage. This code must be copied from QSPI FLASH.

Features

- Cacheable range of up-to 32 MB starting from QSPI start address, adjustable length up to N*64 kB
- Cache size configurable, default is 16 kB, TAG RAM size is 4 kB
- Runtime configurable cache line 8, 16, or 32 bytes
- Runtime configurable 1, 2, or 4-way associativity
- Built-in TAG memory invalidation (FLUSH)
- Random number (LFSR) for 2, 4-way replacement strategy
- Cache Data and TAG monitoring
- Instruction and Data caching upon read access, no write path to cache available
- Bypass mode
- Cache internal latency:
 - Zero wait cycle for cache hits for same cache line
 - One wait cycle for cache hits when changing cache line
 - 4 + (cache line size/4 cycles) for cache misses
 - Zero cycle in transparent bypass mode

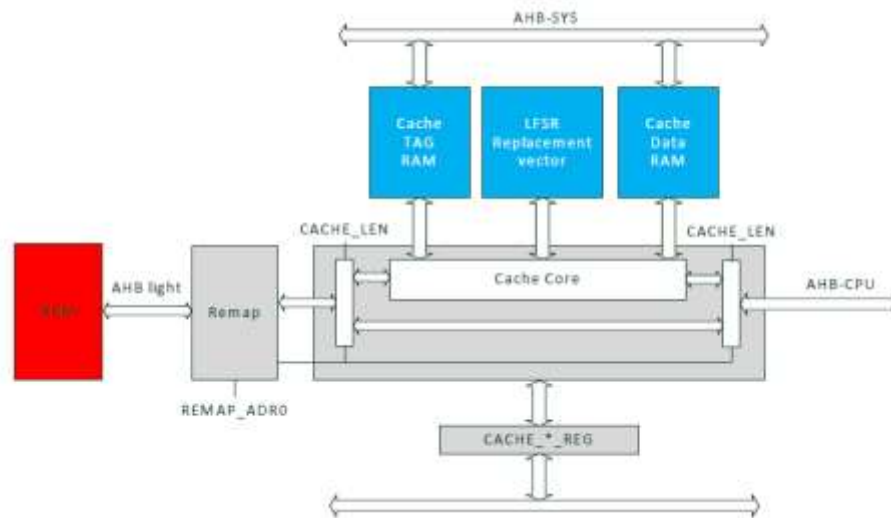

Figure 28. Cache controller block diagram

12.2 Architecture

12.2.1 Cacheable Range

The cache controller caches address range 0-0x1FFFFFFF (32 MB). If `REMAP_ADR0=0x1` or `0x2`, all addresses from 0 to `CACHE_LEN` will be cached, else the cache controller automatically asserts the bypass mode. The bypass mode can be forced for all addresses by setting `CACHERAM_MUX=0`.

Note that the `CACHE_LEN` setting is only applicable for the QSPI FLASH remap case as defined in the `CACHE_FLASH_REG`.

12.2.2 Runtime Reconfiguration

Associativity and cache line size of cache can always be reconfigured by writing the `CACHE ASSOCCFG_REG` or `CACHE_LNSIZECFG_REG` registers. Reconfiguration is done without wait state and without flushing the cache. All the data available in the cache memory are kept except when the associativity is reduced (4-way => 2-way and 2-way => 1-way). In that case, typically half of the data is inaccessible.

12.2.2.1 Cache Line Reconfiguration

The dynamic configuration of the cache line size uses a physical line size of 8 B. When the cache line size is defined as 16 B or 32 B, 2 or 4 physical lines are involved. Reconfiguration of the cache line occurs only when lines are replaced. Even if the cache line configuration is set to 32 B, cache lines of 16 B may remain in the cache memory. This is explained by means of example in [Figure 29](#).

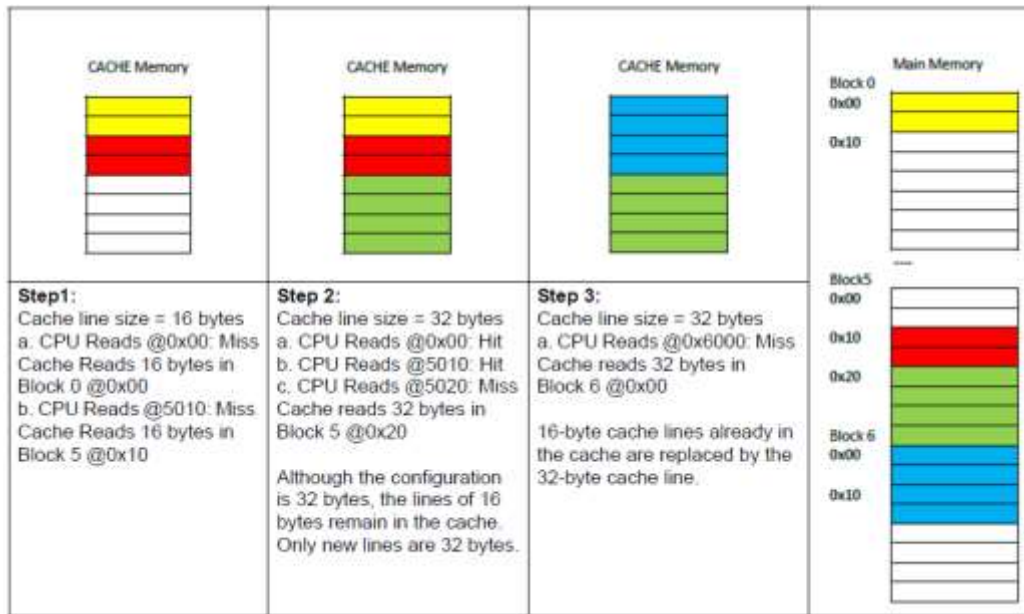

Figure 29. Cache line size reconfiguration example

12.2.2.2 TAG Memory Word

The administration memory word decoding is presented in Table 87.

Table 87: TAG Memory layout

Bit 23	Bits 22:2	Bits 1:0
0	AHB address	00: invalid cache line 01: 8 valid bytes 10: 16 valid bytes 11: 32 valid bytes

12.2.2.3 Associativity Reconfiguration

To enable associativity reconfiguration, the cache memory is organized into four banks. Depending on the associativity, the four banks can operate as 4-way, or be concatenated (linked together), resulting in either a 2-way or 1-way cache.

12.2.3 Replacement Strategy

The cache controller fills each line of the cache first, starting from way-0 to way-3. When a line is completely full, a new way-x victim is chosen in a pseudo random way. When a replacement is required, the cache controller reads the value generated by a pseudo-random number generated to select which way to replace. The pseudo-random number generator is realized using a Linear Feedback Shift Register (LFSR).

12.2.4 Cache Reset

The cache controller has two reset signals connected:

- The HW_RESET: When this reset is activated, all cache logic and registers are reset to their default values, while all data in the TAG memories are cleared and all CACHE_*_REG are set to their reset values. It takes around 450 AHB cycles to clear the cache TAG memory. If a fetch request occurs during this reset period, the request is considered at the end of the reset and wait-states are inserted
- The SW_RESET: Upon a SW_RESET the cache state machine and TAG memories are reset, but the CACHE_*_REG are not affected and remain as programmed

12.2.5 Miss Rate Monitor

The system includes a cache miss, which monitors circuitry that gives real time information on the number of cache misses within a certain amount of time. When a programmable threshold is reached, an interrupt is sent to the CPU to act. The CPU can dynamically change the cache line size, the associativity, or start the PLL to

decrease cache line fetch time, and consequently power. It can even apply a combination of these techniques to adjust the system's parameters accordingly. This block only operates while the system is in active mode. The main features are:

- Up to 10 ms active time interval counter
- Registered amount of cache misses
- Registered amount of cache hits
- Programmable threshold of cache misses that generates an interrupt.

The CACHE_MRM_HITS_REG contains the amount of cache hits. The CACHE_MRM_MISSES_REG contains the number of misses counted within the time interval programmed at the CACHE_MRM_TINT_REG in CPU clock cycles.

12.2.6 Miss Latency and Power

This section describes the amount of time (in clock cycles) required from a cache miss up to the point the required code/data are fetched back to the CPU and execution continues. The cache miss latency (T_{CML}) can be split into the following intervals:

T_{CM2R} : Time from the cache miss up to request from the QSPI Controller.

T_{R2QA} : Time from request up to actual access start.

T_{RDFL} : Time for reading data from the FLASH.

T_{CLAT} : Time required to get data to the CPU (cache latency).

The final amount of clock cycles is calculated by the following equation:

$$T_{CML} = T_{CM2R} + T_{R2QA} + T_{RDFL} + T_{CLAT}$$

where T_{RDFL} depends on the amount of data requested and is provided by the following formula:

$$T_{RDFL} = T_{CMD} + T_{ADDR} + T_{DUM} + (N_{CACHELINE} * 2) + T_{PIPE}$$

For example, give a cache line configuration of 16 bytes, the amount of clock cycles required to read the data from the FLASH is:

$$T_{RDFL} = 2 + 8 + 4 + (16 * 2) + 1 = 47 \text{ clock cycles.}$$

An overview of the cache miss latency calculation is shown in [Table 88](#).

Table 88: QSPI Flash cache miss latency

Time interval	Clock cycles	Example
T_{CM2R}	3	3
T_{R2QA}	2	2
T_{RDFL}	$T_{CMD} + T_{ADDR} + T_{DUM} + (N_{CACHELINE} * 2) + T_{PIPE}$	47
T_{CLAT}	4	4
T_{CML}	for 16 B cache line (QPI mode)	56

12.3 Programming

12.3.1 Cache Controller Programming

There is a simple sequence of steps that needs to be followed to configure the Cache Controller:

1. Disable the Cache by clearing the CACHE_CTRL2_REG[CACHE_LEN] bit field.
2. Set up the Cache RAM size by programming CACHE_CTRL_3_REG[CACHE_RAM_SIZE_RESET_VALUE]
3. Set up the Cache line size (CACHE_LNSIZECFG_REG). Default is 8 B.
4. Set up the Cache associativity (CACHE ASSOCCFG_REG). Default is 4-way associativity.
5. Flush Cache contents (CACHE_CTRL1_REG[CACHE_FLUSH]).

6. Enable the cache (`CACHE_CTRL2_REG[CACHE_LEN] != 0`).
The size of the cacheable QSPI Flash memory can be specified in `CACHE_CTRL2_REG[CACHE_LEN]` when `CACHE_CTRL2_REG[CACHE_LEN] != 1`. If `CACHE_CTRL2_REG [CACHE_LEN] = 1`, then the memory space is specified by `CACHE_FLASH_REG [FLASH_REGION_OFFSET]`.

12.3.2 Miss Rate Monitor Programming

There is a simple sequence of steps that needs to be followed to configure the Miss Rate Monitor:

1. Freeze all counters by clearing the `CACHE_MRM_CTRL_REG[MRM_START]` bit.
2. Set up the thresholds that produce interrupts:
 - a. Cache Misses threshold: `CACHE_MRM_MISSES_THRES_REG[MRM_MISSES_THRES]`
 - b. Cache Hits threshold: `CACHE_MRM_HITS_THRES_REG[MRM_HITS_THRES]`
 - c. Time passed threshold: `CACHE_MRM_TINT_REG[MRM_TINT]`
3. Unmask all interrupts by setting the `CACHE_MRM_CTRL_REG[MRM_IRQ_MASK]` bit.
4. Enable the chosen interrupts:
 - a. `CACHE_MRM_CTRL_REG[MRM_IRQ_HITS_THRES_STATUS]`: The number of cache hits reached the programmed threshold.
 - b. `CACHE_MRM_CTRL_REG[MRM_IRQ_MISSES_THRES_STATUS]`: The number of cache misses reached the programmed threshold.
 - c. `CACHE_MRM_CTRL_REG[MRM_IRQ_TINT_STATUS]`: The time interval counter reached the end.
5. Enable all counters by setting the `CACHE_MRM_CTRL_REG[MRM_START]` bit.
6. Read the results (misses and/or hits) in the `CACHE_MRM_MISSES_REG` and `CACHE_MRM_HITS_REG` registers.

13. Bus

Device:	DA14691	DA14695	DA14697	DA14699
Feature Availability:	✓	✓	✓	✓

13.1 Introduction

The DA1469x is equipped with a multi-layer AMBA bus, which enables parallel data paths between different masters and slaves.

The bus matrix comprises three main busses:

- AHB-CPUC bus where the Cache is master. This is the primary bus from which code is executed. Memory map range is 0x00000000- 0x1FFFFFFF
- AHB-CPUS bus, where the Cortex-M33 is master. This is the bus for the system. The memory map range is 0x20000000- 0xDFFFFFFF and beyond 0xE0100000
- AHB-DMA bus where the RFMON, the Generic DMA, the LCD Controller, and the AES/HASH can be masters

There are several slaves, sitting behind interconnection multiplexers (ICMs), that allow access from both AHB busses; namely:

- QSPI Flash memory controller
- QSPI RAM memory controller
- 32-bit APB peripheral registers
- The RAM controller
- The OTP controller
- The AHB register file containing registers for the QSPI Flash/RAM controller, the CMAC, the Crypto the OTPC, and so forth

Features

- Enables parallelization of data transfers from:
 - Peripherals to memory (GP DMA)
 - Cortex-M33 data read/writes from RAM
 - Cortex-M33 executing code from QSPI FLASH
- Supports parallel accessing of Sensor Node, GP DMA, MACCPU, and SYSCPU on (different) memory segments without collisions

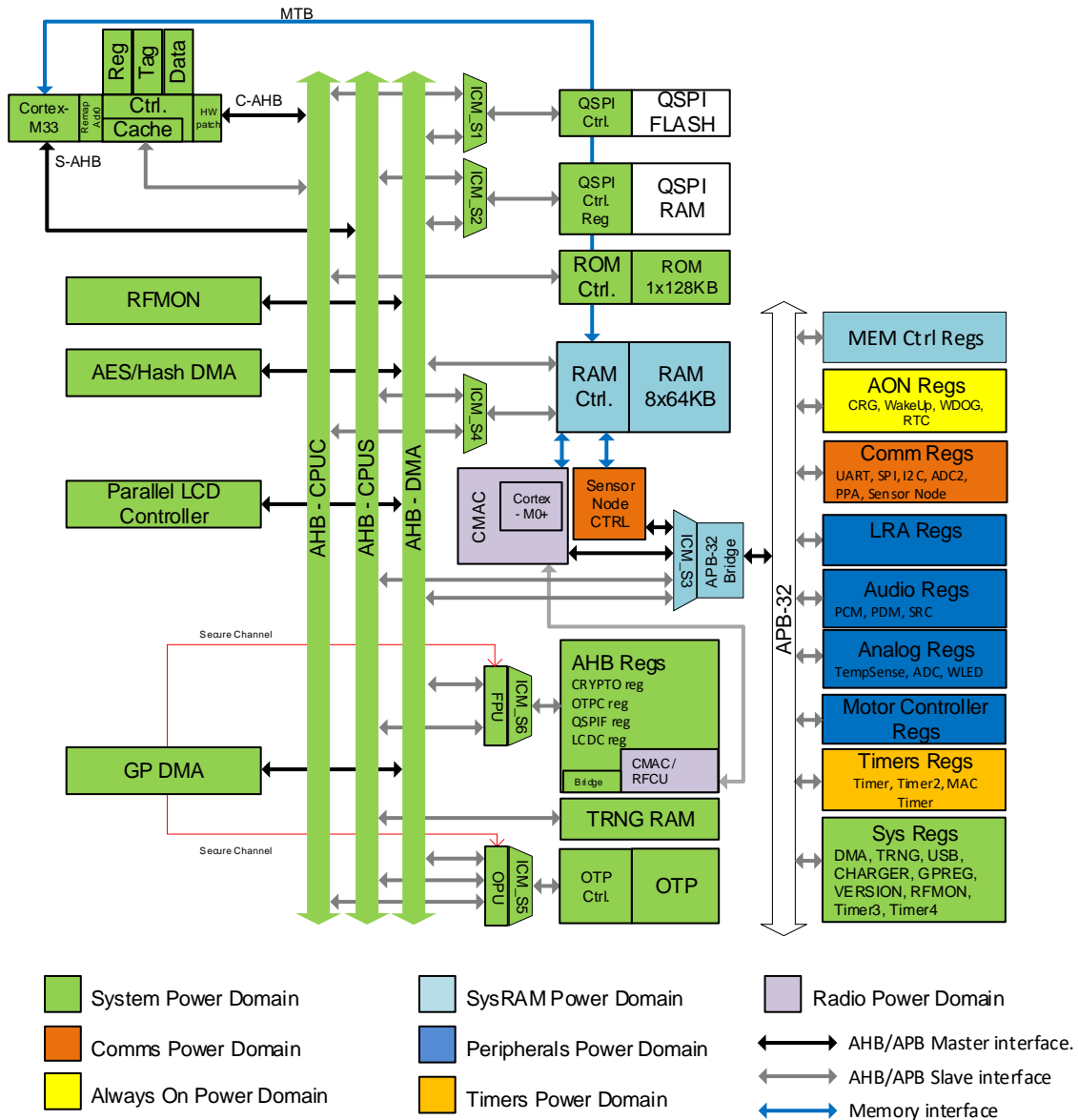

Figure 30. Bus architecture

13.2 Architecture

Figure 30 shows the architecture of the AMBA bus matrix. There are four potential masters for the APB32, namely: Sensor Node Controller, CMAC, Cortex-M33, and the DMA engines. A multiplexer is required there to allow access to a single master on the APB32 multiplexing, between the Sensor Node and the bridge.

There are two protection units – (1) the OTP Protection Unit (OPU), and (2) the Flash Controller Register Unit (FPU)] – that form part of the system’s security perimeter:

- The OPU protects the OTP section where keys are stored; keys that the CPU cannot read. Access to this space is only allowed when a special signal (secure channel). Read/Write protection strategy should follow the sticky bits definition.
- The FPU protects the QSPI Flash Controller registers that keep the AES key (write only) from being written by the CPU and the AES/HASH registers from being read by the CPU. Access is only allowed by the GP DMA and only if the respective secure channel signal is activated. Rest of accesses to other register files are completely transparent and will not be gated by the FPU. Read/Write protection strategy should follow the sticky bits definition.

The priorities of the arbitration on the AHB-DMA bus should be programmable since the LCD DMA can actually occupy the bus continuously. The default priorities are listed in Table 89.

Table 89: AHB-DMA master priorities

Priority	Master
1	RFMON
2	LCD Controller
3	GPDMA
4 (lowest)	AES/HASH

14. Configurable MAC (CMAC)

Device:	DA14691	DA14695	DA14697	DA14699
Feature Availability:	✓	✓	✓	✓

14.1 Introduction

The Configurable Medium Access Controller (CMAC) is a Flexible MAC HW block, based on Arm Cortex-M0+ that can be programmed to support multiple protocols.

The CMAC executes code from the system RAM with zero wait states. It also has access to all APB peripherals of the system.

Features

- Implements Bluetooth® LE 5.x controller stack, including HCI
- Optional Bluetooth® LE 5.x Features supported:
 - 2 Mbps
 - Advertising Extensions
 - Channel selection algorithm #2
 - Periodic Advertising
 - High Duty Cycle Non-Connectable Advertising
- Autonomous operation for Advertising or keep-alive connections
- Autonomous execution and sleep cycles
- Rapid wake-up and go-to-sleep operation
- Size and base address of RAM for code execution is configurable
- Accelerators in hardware:
 - Link Layer and framing Timers
 - AES-128-bit crypto engine
 - Whitening 7-bit engine, compliant with Bluetooth® LE standard
 - CRC 24-bit engine, compliant with Bluetooth® LE standard
 - 32 bits wide Correlator
 - AoA/AoD support in HW
 - Coexistence interface

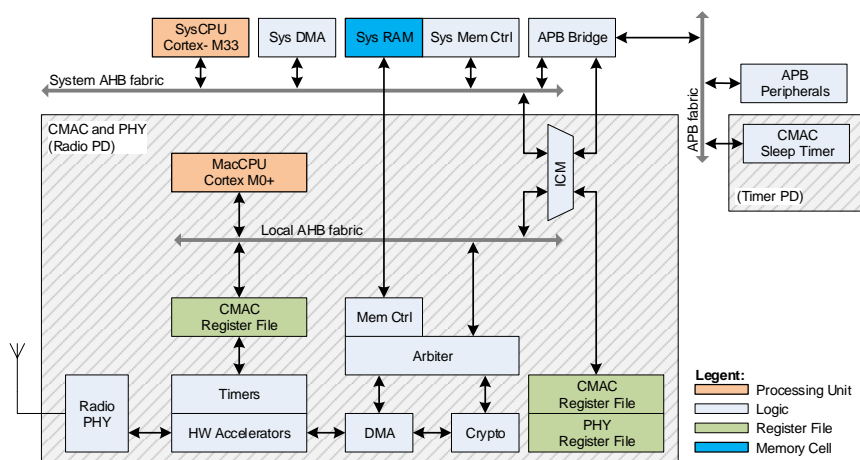

Figure 31. Configurable MAC block diagram

14.2 Architecture

The CMAC block is an autonomous system that can execute Bluetooth® LE and other protocols if there is enough hardware accelerators and Firmware throughput.

A dedicated Cortex-M0+ executes code through the local memory controller, which reuses the system memory RAM for storing code and data. A hardware bit stream controller performs all real time functions by using hardware accelerators like whitening, CRC, and crypto engines. A Link Layer Timer schedules protocol operations and radio transactions. The radio transactions are programmed to the CMAC registers. The HW will execute them automatically in the scheduled moment, activating the proper accelerators.

Radio Register File and CMAC Sleep Timer Register Files are accessible by both CPUs, but typically only CMAC CPU access them.

14.2.1 Dataflow

CMAC can implement the Bluetooth® LE Data Link Layer, providing an HCI interface towards the system processor Cortex-M33.

The communication of CMAC processor Cortex-M0+ with the system processor Cortex-M33 is performed via IRQ signals and the common system memory RAM. A mailbox mechanism can be used to exchange command and data structures between the two CPUs.

14.2.2 Diagnostics

Table 90 shows available CMAC diagnostics signals.

Table 90: CMAC diagnostic signals

Diagnostics	Signal	Description
CMAC_DIAG_0	TX EN	Data transmit enable signal
CMAC_DIAG_1	RX EN	Data receive enable signal
CMAC_DIAG_2	DATA EN	Tx/Rx Data Enable pulse
CMAC_DIAG_3	DATA COMB	TX and RX data bits (combined on the same line)
CMAC_DIAG_4	Reserved	-
CMAC_DIAG_5	Reserved	-
CMAC_DIAG_6	Reserved	-
CMAC_DIAG_7	CORR COMB	Indicates that the correlator is active
CMAC_DIAG_8	CRC	RX CRC LFSR is zero to indicate correctly received packet
CMAC_DIAG_9 to 15	Reserved	-

The functionality of the diagnostic signals is depicted in Figure 32.

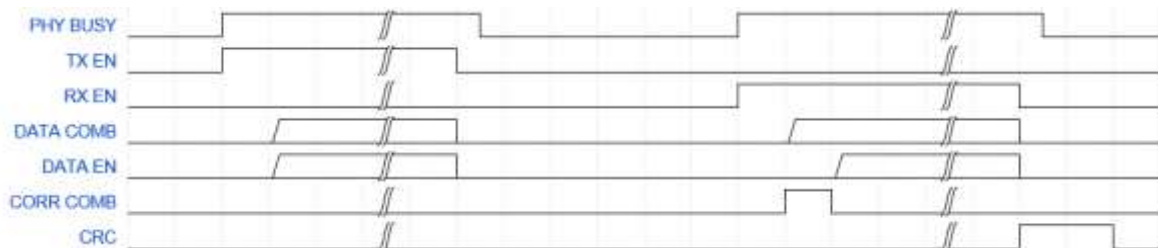

Figure 32. CMAC diagnostics timing diagram

15. Sensor Node Controller (SNC)

Device:	DA14691	DA14695	DA14697	DA14699
Feature Availability:	✓	✓	✓	✓

15.1 Introduction

The Sensor Node Controller is a sophisticated hardware state machine, implementing a very short list of instructions that are enough to create small programs to manipulate communication controllers and the sensors connected to them. It is very small and can operate autonomously, without waking up the rest of the system. The minimum instruction set allows for polling sensor status bits, compare register to memory values, transfer data from communication interfaces to system RAM, branch on comparison and the like, as well as dissipating minimal current.

Features

- Minimal Instruction Set for Sensor manipulation uCode generation
- System RAM used for uCode storage as well as data
- DMA capabilities for storing data directly from serial interfaces to system RAM
- Immediate execution after domain power up and interrupt pending
- Running at system clock speed or less (programmable)

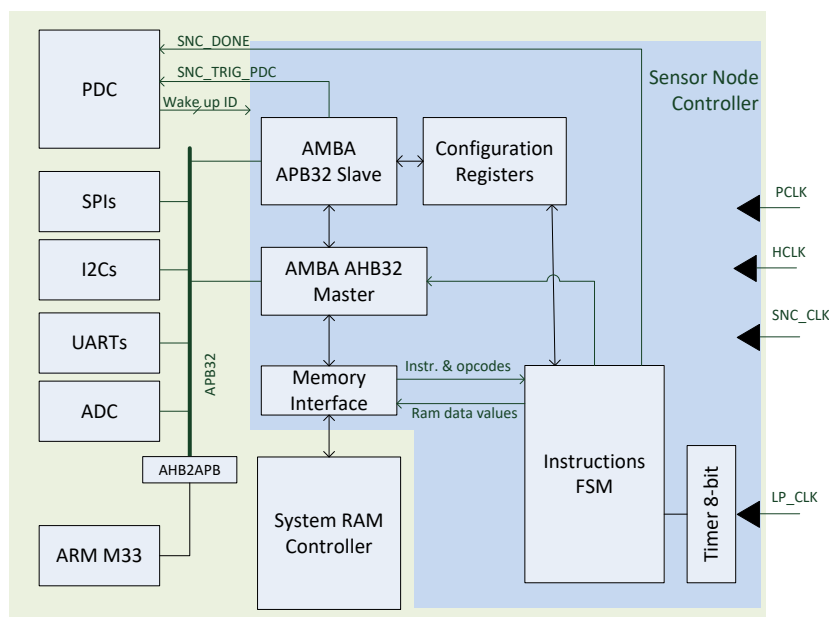

Figure 33. Sensor node controller block diagram

15.2 Architecture

The Sensor Node Controller is a master on the AHB bus. It resides in the same power domain as all the communication interfaces and $\Sigma\Delta$ ADC. It can control other power domains connected to the APB32 bus.

The actual micro-code resides in the System RAM. The Sensor Node Controller has a direct memory connection to the System RAM. It operates at system clock speed. It can generate an interrupt that tells the Power Domains Controller the sensor reading operations are done, and the whole system can now be powered OFF.

Since the Sensor Node Controller can be activated at the same time as the system CPU, the BUSY Status Register (BSR) can indicate the availability of the communication interfaces. The System CPU should always check the BSR before accessing any of the communication interfaces, to make sure there is no conflict.

The Sensor Node Controller comprises the following blocks as shown in [Figure 23](#):

- The Instructions FSM (I_FSM) with the 8-bit Timer. This HW FSM, implements a minimized proprietary instruction set, which is tailored to the Sensors interfacing and data acquisition. This instruction set is described in detail in the following section. The 8-bit Timer is used to implement a precise delay. It is controlled by one of the instructions
- A memory interface. This interface reads instructions the I_FSM executes from the system RAM. It also stores data fetched from sensors via the communication interfaces, using the master APB32 interface
- A master AHB. Implements writing and reading to communication and peripheral controllers
- A slave APB32 used for configuring the internal registers. This is supposed to happen by the Arm Cortex-M33 CPU during initialization of the system. Base addresses in System RAM of the uCode and data buffers for the various sensors support, should be defined in the register file
- A register file. This file contains registers needed to configure basic functions of the Sensor Node (r/w), and the registers holding the currently executed opcode and the program counter (read-only, for debugging purposes)

15.2.1 Sensor Node Instruction Set

The Sensor Node Instruction Set (SeNIS) is summarized in [Table 91](#).

Table 91: Sensor Node Instruction Set Overview

Command	Operand1	Operand2	Description
WADAD	Value indicating an Address 1+19=20 bits MSbit=1, Register MSbit=0, RAM	Pointer to RAM/register indicating an Address 1+19 bits MSbit=0, RAM MSbit=1, Register	Stores contents of Reg/RAM defined by the pointer in Operand2 into the address defined by the value of Operand1. Bit 27 = 0: [Operand1] Bit 27 = 1: (Operand1) Bit 26 = 0: (Operand2) Bit 26 = 1: [Operand2]
WADVA	Value indicating an Address 1+19=20 bits MSbit=1, Register MSbit=0, RAM	Value 32 bits	Stores value in Operand2 into the address defined by the value of Operand 1. Bit 27 = 0: [Operand1] ← Operand2 or Bit 27 = 1: (Operand1) ← Operand2
TOBRE	Value indicating an Address 1+19=20 bits MSbit=1, Register MSbit=0, RAM	Mask 32 bits	XOR the value with the mask. If mask contains 1 at a specific bit place, then this bit's value is toggled. (Operand1) ← (Operand1) XOR Operand2
RDCBI	Value indicating an Address 1+19=20 bits MSbit=1, Register MSbit=0, RAM	Bit place (0 to 31)	Reads and compares the contents of Reg/RAM defined by the value of Operand1 with "1" at the bit place. If (Operand1):(Operand2)=1 then EQUALHIGH_FLAG=true
RDCGR	Value indicating an Address 1+19=20 bits MSbit=1, Register MSbit=0, RAM	Value indicating an Address 1+19=20 bits MSbit=1, Register MSbit=0, RAM	Compares contents residing in the Address defined by Operand1 with contents residing in the Address defined by Operand2. If (Operand1)>(Operand2) then GREATERVAL_FLAG=true
COBR	Value indicating a RAM Address 20 bits (20 th bit is don't care)	Branch according to EQUALHIGH_FLAG or GREATERVAL_FLAG or For a specific number of times	<ul style="list-style-type: none"> ▪ If Operand2= 0x0A, then branch to (Operand1) address if EQUALHIGH_FLAG=True ▪ If Operand2= 0x1A, then branch to [Operand1] address if EQUALHIGH_FLAG=True ▪ If Operand2= 0x05, then branch to (Operand1) address if GREATER_FLAG=True

Command	Operand1	Operand2	Description
			<ul style="list-style-type: none"> ▪ If Operand2= 0x15, then branch to [Operand1] address if GREATER_FLAG=True ▪ Operand2= 0b1yyyyyyy, then branch to (Operand1) address for up to 128 times
INC	Value indicating a RAM Address 1+19 = 20 bits	None	<p>Increments the content of (Operand1) memory address either by 1 (default) or by 4, depending on bit [19] of Operand1, as follows:</p> <p>Operand1[19] = 0 : (Operand1) ← (Operand1) + 1</p> <p>Operand1[19] = 1 : (Operand1) ← (Operand1) + 4</p>
DEL	Value indicating a number of clock ticks 8 bits	None	Starts a delay of <Operand1> ticks, where a tick is an internal 8-bit timer running on the sleep clock (32 kHz). After timer expires, program execution continues.
SLP	None	None	Designates the end of the execution. Automatically generates a signal pulse to the Power Domains Controller to set the system in sleep and power down the Sensor Controller.
NOP	None	None	No Operation.

(Operand): When in simple brackets, then the Operand's value is an address to either System RAM or a Register (direct addressing).

[Operand]: When in square brackets, then the Operand's value is a pointer to a memory space in which the requested address resides (indirect addressing).

The actual opcodes and Operand sizes of each of the instructions are shown in [Table 92](#):

Table 92: Opcode and operand sizes

Instruction	Opcode (4 bits)	Operand1 size	Operand2 size	Addressing bits
NOP	0x0	-	-	-
WADAD	0x1	20 bits	20 bits	2 bits
WADVA	0x2	20 bits	32 bits	1 bit
TOBRE	0x3	20 bits	32 bits	-
RDCBI	0x4	20 bits	5 bits	-
RDCGR	0x5	20 bits	20 bits	-
COBR	0x6	20 bits	8 bits	-
INC	0x7	20 bits		
DEL	0x8	8 bits		
SLP	0x9			
Reserved	0xA – 0xF			

15.2.2 SNC Clocking Considerations

If the LP clock is used as system clock, the SNC clock should be equal to the LP clock. If the SNC clock is divided, the DEL command may not function properly. The proper configuration demands the register be:

- CLK_AMBA_REG[HCLK_DIV] = 0
- CLK_AMBA_REG[PCLK_DIV] = 0
- CLK_COM_REG[SNC_DIV] = 0

15.3 Programming

Programming the Sensor Node Controller for use requires a simple sequence of steps. There is a detailed library of macros available for manipulating interfaces. The following steps explain the controller's initialization and configuration.

1. Load the SNC execution code into the RAM.
2. Set up the SNC clock by configuring the clock divider (CLK_COM_REG[SNC_DIV]).
3. Set up the SNC base address (SNC_BASE_REG).
4. Execute the code:
 - a. Using PDC: Set up PDC entry.
 - b. Manual code execution:
 - i. Disable PDC triggering by setting the SNC_CTRL_REG[SNC_SW_CTRL] bit.
 - ii. Enable the SNC by setting the SNC_CTRL_REG[SNC_EN] bit.
 - iii. Check the SNC_STATUS_REG[SNC_DONE_STATUS] bit:
0: Indicates the SNC is running.
1: Indicates the SNC has finished the code execution.

16. Memory Controller

Device:	DA14691	DA14695	DA14697	DA14699
Feature Availability:	✓	✓	✓	✓

16.1 Introduction

The memory controller allows access to the 512 kB RAM (384 kB on DA14691) pool by the system's masters; these include the: SysCPU, MACCPU Sensor Node Controller, General Purpose DMA controller, and LCD Controller. It comprises two AHB ports (GPDMA and SysCPU) and three Memory ports (Sensor Node Controller, MACCPU, and Micro Trace Buffer (MTB)).

The memory controller implements an intelligent addressing scheme so that RAM is not fragmented by various data or code allocations. At the same time, it allows parallel access of multiple data streams on different RAM cells, transparent to the application software. So, it allows the System CPU to store/read application variables, while the MAC CPU executes code, the LCD reads a frame buffer and the Sensor Node stores sensor data at the same time, without conflict and arbitration that would result in wait states.

Definition of the different segments allocated in memory, is fully programmable. In cases where two or more segments are sharing the same RAM cell, hardware arbitration will resolve conflicts by issuing wait states to the masters having the least priority.

Features

- Supports flexible memory allocation per master to avoid fragmentation
- Parallelizes data flows from/to various masters on the system
- Allows for programmable priority scheme per RAM cell
- Generates wait cycles to AHB masters

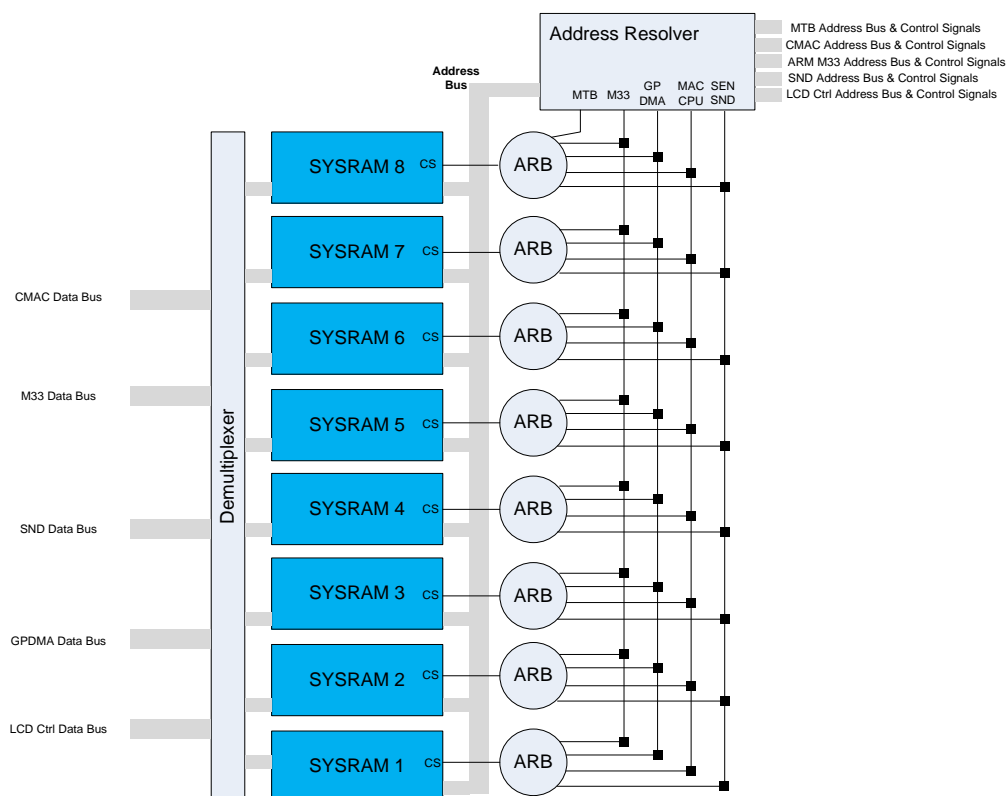

Figure 34. Internal architecture of the memory controller

16.2 Architecture

The internal architecture of the memory controller is shown in [Figure 34](#).

Where two or more masters need access to the same RAM cell but different addresses (each on its own segment), then arbitration is used. If wait cycles (for the least prioritized) are not acceptable, a reconfiguration of the segment boundaries, at the cost of some RAM fragmentation, should be considered.

All masters should support a “Ready” like signal functionality, so that they can be stalled for a specific amount of clock cycles. This makes the arbitration signals for the AHB interfaces (SysCPU, Parallel LCD and GP DMA) HREADY, while the memory interfaces (Sensor Node and MTB) should also support a respective input (MREADY) and should only proceed in reading/writing the RAM cell if this signal is high.

The CMAC does not support any MREADY functionality, so it always has the highest priority.

An overview of the basic metrics of each master accessing the memory controller is shown in [Table 93](#).

Table 93: Memory controller masters access metrics

Master	Frequency range	Stall mechanism	Access rate	Wait states tolerance
Cortex-M33	32 MHz – 96 MHz	AHB HREADY	Non-burst accesses for data and/or code	Should keep that < 4 AHB clocks to avoid performance degradation
CMAC	32 MHz – 96 MHz	None	Non-burst accesses for data and/or code	0
MTB	32 MHz – 96 MHz	None	Non-burst accesses for data and/or code	0
Sensor Node	2 MHz – 32 MHz	MREADY signal	Up to 8-beat burst access for data. Non-burst for code	It Is application dependent. We should keep that <10 clocks
GP DMA	32 MHz – 96 MHz	AHB HREADY	8-beat	< 6 AHB clocks
LCD Controller	32 MHz – 96 MHz	AHB HREADY	8-beat burst access for data.	< 6 AHB clocks

Two different arbitration schemes are provided:

- Static priority of masters. The MEM_PRIO_REG defines three fields, one for each AHB layer and a third for the Sensor Node Controller. The priority level of each channel can be defined by programming these fields. Arbitration is always done in favor of the highest priority master.
- Round Robing priority of masters. To avoid stalling a master for very too long, another register (MEM_STALL_REG) can be programmed with the maximum amount of clock cycles that a channel might be stalled. As soon as this number is reached, this channel will automatically retrieve highest priority

Programming the MEM_STALL_REG with values other than 0, enables the second scheme.

16.3 Programming

Programmability is required for the range (Start and Stop address) of segments that need to be defined in the memory, depending on the type and size of the application. The following list contains the least number of segments needed for proper operation of the system.

Table 94: Memory segments description

Segment name	Description	Access	Start/Stop address registers
CMAC stack	Controller stack code and temporary variables	Cortex-M0+ (read, write) Cortex-M33 (write) DMA (write)	CMAC_CODE_BASE_REG (Note 1) CMAC_DATA_BASE_REG CMAC_END_REG
Mailbox	Implements the structure which is used for exchanging commands and data between the 2 CPUs	Cortex-M0+ (read, write) Cortex-M33 (read, write)	

Segment name	Description	Access	Start/Stop address registers
Cortex-M33 Code	Special code segment for SysCPU. HW Patching code can be placed here as well	Cortex-M33 (read, write)	
Cortex-M33 Data	Application data space	Cortex-M33 (read, write) GP DMA (read, write)	
Sensor Node uCode	SeNIS uCode space	Sensor Node (read) Cortex-M33 (write) GP DMA (write)	
Sensor Node Data	Buffers for storing data read from Sensor Node Operation	Sensor Node (write) Cortex-M33 (read) Cortex-M0+ (read) GP DMA (read)	SNC_CODE_BASE_REG
System	IVT and others	0x00000	0x000800

Note 1 This value should also be programmed in the Cortex-M33 MPU region 1 to ensure the Application does not corrupt CMAC code/data.

Figure 35 shows an example of an actual mapping of the segments mentioned. This is not mandatory but is recommended.

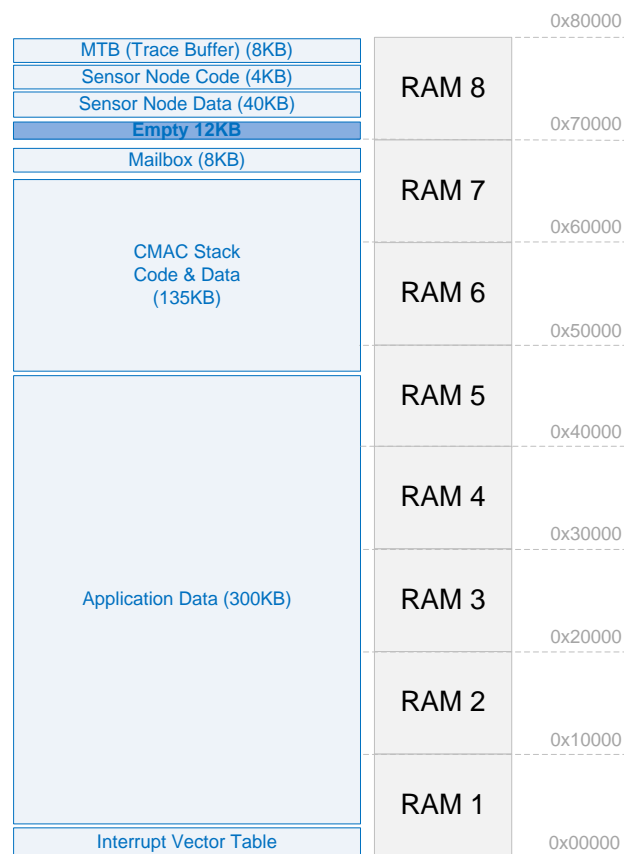

Figure 35. Example of memory segments mapping

In the example in Figure 35, there is no memory fragmentation other than at RAM8. This is the RAM where the Micro Trace Buffer (MTB) is allocated. In this case, MTB which has no stalling mechanism, should have the highest priority. The rest of the allocated MTB RAM can still be used for other masters, but not for CMAC, because this master also has no stalling mechanism. So, CMAC and MTB should not be allocated on the same RAM cell.

The rest of the RAM cells can be accessed by multiple masters, all at the same time. Arbitration on every cell is required to manage this. This means wait states insertion for the masters.

A different layout can be selected to solve such conflicts. This is done by defining frequent users of the memory on different RAM cells. This improves performance (no wait states) at cost of memory fragmentation (empty holes in the memory space).

17. Clock Generation

Device:	DA14691	DA14695	DA14697	DA14699
Feature Availability:	✓	✓	✓	✓

17.1 Clock Tree

[Figure 36](#) shows the generation of the system's clocks.

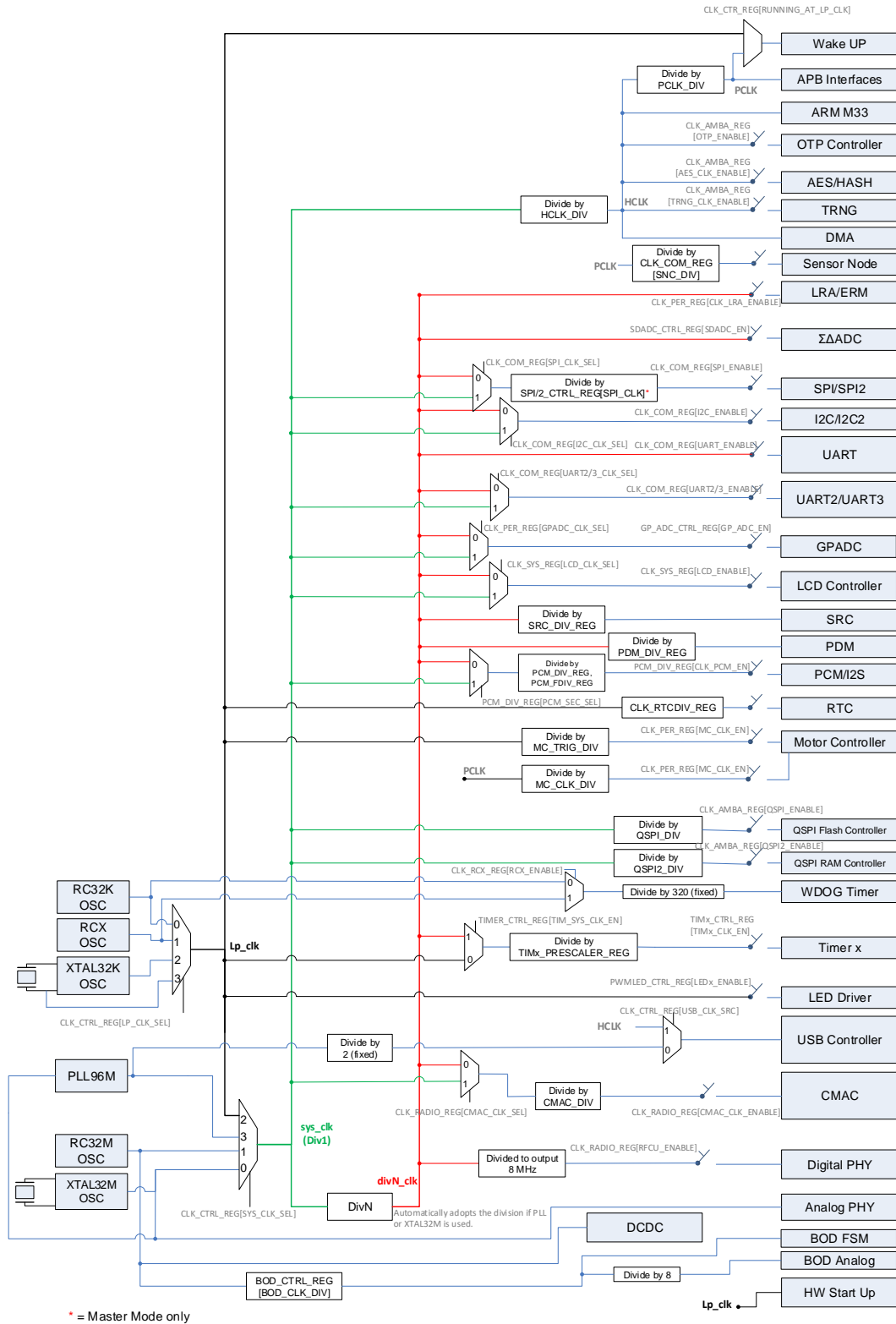

Figure 36. Clock tree diagram

The diagram shows the possible clock sources and all different divisions and multiplexing paths towards the generation of each block's clock. Also, the required registers that must be programmed, are also labelled on the same diagram. There are some main clock lines which are of interest:

- **lp_clk** (black bold line): this is the low power clock used for the sleep modes and can only be the RCX, RC32K or XTAL32K
- **sys_clk** (green line): this is the system clock, used for the AMBA clock (hclk) - which runs the CPU, memories, and the bus. The source of this clock can be any oscillator, the PLL, or even an externally supplied digital clock
- **divn_clk** (red line): this is a clock which automatically adjusts the division factor on the sys_clk to always generate 32 MHz. This enables the dynamic activation of the PLL to provide more processing power at the CPU, without affecting the operation of blocks designed for 32 MHz

Using the PLL and dividing the sys_clk by 2 while accessing peripherals should not be programmed. The apb_clk will be a multiple of 48 MHz while the actual blocks will be operating on 32 MHz. Hence, synchronization issues might be observed. If not accessing peripherals, the CPU can operate at 48 MHz without a problem.

17.2 Crystal Oscillators

The Digital Controlled Xtal Oscillators (DXCO) are designed for low power consumption and high stability. There are two such crystal oscillators in the system, one at 32 MHz (XTAL32M) and a second at 32.768 kHz (XTAL32K). The 32.768 kHz oscillator has no trimming capabilities and is used as the clock of the Extended Sleep mode. The 32 MHz oscillator can be trimmed.

The principal schematic of the two oscillators is shown in [Figure 37](#). No external components to the DA1469x are required other than the crystal itself. If the crystal has a case connection, it is advised to connect the case to ground.

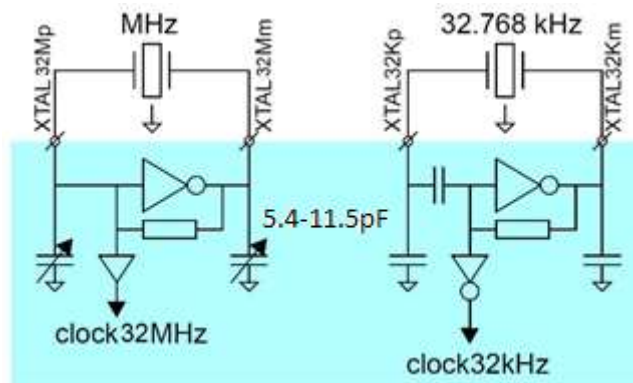

Figure 37. Crystal oscillator circuits

17.2.1 Frequency Control (32 MHz Crystal)

Register CLK_FREQ_TRIM_REG controls the trimming of the 32 MHz crystal oscillator. The frequency is trimmed by two on-chip variable capacitor banks. Both capacitor banks are controlled by the same register.

With CLK_FREQ_TRIM_REG[XTAL32M_TRIM] = 0x2BF the maximum capacitance, and minimum frequency is selected. With CLK_FREQ_TRIM_REG[XTAL32M_TRIM] = 0x000 the minimum capacitance, and maximum frequency is selected.

The ten least significant bits of CLK_FREQ_TRIM_REG register (XTAL32M_TRIM bit field) directly control ten binary weighted capacitors, as shown in [Figure 38](#).

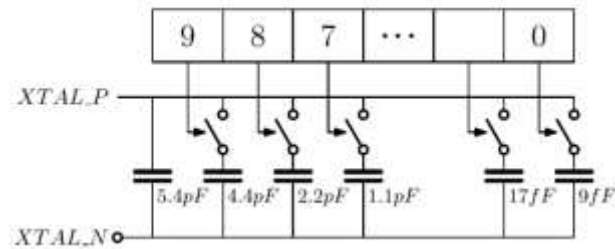

Figure 38. XTAL32MHz oscillator frequency trimming

17.3 RC Oscillators

The DA1469x has three RC oscillators:

- RC32M generates 32 MHz when trimmed accordingly
- RC32K generates ~32 kHz (but ranges from 23 kHz to 37 kHz depending on the temperature)
- RCX generates ~15 kHz (see specifications chapter for min/max range)

The 32 MHz RC oscillator is powered by the Digital LDO VDD, which is available for the core logic during Active or Sleep mode. The output clock is significantly slower than 32 MHz if untrimmed and is used to clock the CPU and the digital part of the chip during power up or wake up, while the XTAL32M oscillator is settling.

The simple RC oscillator (RC32K) operates on VDD. The RC32K oscillator is used in the following cases:

- For internal clocking during power up or startup. It clocks the hardware state machine which brings up the power management system of the chip.
- For clocking the watchdog if this clock source is selected
- For clocking the POReset mechanism as explained in the Reset chapter.

The enhanced RC oscillator (RCX) generates ~15 kHz. The RCX oscillator can be used to replace the 32.768 kHz crystal, since it has a precision of < 500 ppm, while its output frequency is quite stable over temperature.

17.3.1 Frequency Calibration

The output frequency of the 32 kHz crystal oscillator and the three RC-oscillators can be measured relative to the DivN clock, using the on-chip reference counter.

The measurement procedure is as follows:

- $REF_CNT_VAL = N$ (the higher N, the more accurate and longer the calibration will be)
- $CLK_REF_SEL_REG[REF_CLK_SEL] = 0$ (RC32K) or
 $CLK_REF_SEL_REG[REF_CLK_SEL] = 1$ (RC32M) or
 $CLK_REF_SEL_REG[REF_CLK_SEL] = 2$ (XTAL32K) or
 $CLK_REF_SEL_REG[REF_CLK_SEL] = 3$ (RCX)
 $CLK_REF_SEL_REG[REF_CLK_SEL] = 4$ (RCOSC)
- Start the calibration: $CLK_REF_SEL_REG[REF_CAL_START] = 1$
- Wait until $CLK_REF_SEL_REG[REF_CAL_START] = 0$
- Read $CLK_REF_VAL_REG = M$ (32-bits value)
- $Frequency = (N/M) * 32\text{ MHz}$

In the case of using the RCX as a sleep clock, the frequency calibration should be implemented at a frequency that ensures Bluetooth® LE connection maintenance.

17.4 PLL

The low power PLL multiplies the XTAL32M clock to produce a 96 MHz clock with very high precision within a few μ s.

Changing the system's clock in to the PLL output can be done dynamically without affecting the operation of the chip. Its main purpose is to:

- Provide a divided by 2, 48 MHz required for the operation of the USB Controller
- Provide more processing power to the CPU, enabling 144 dMIPS, for computational hungry applications

18. OTP Controller

Device:	DA14691	DA14695	DA14697	DA14699
Feature Availability:	✓	✓	✓	✓

18.1 Introduction

The OTP controller realizes all functions of the 4 kB OTP macro cell. The controller facilitates all data transfers (reading and programming). The controller comprises two AHB slave interfaces, one for the configuration registers and one for the actual OTP memory cell. The OTP memory space is transparently read by the CPU, but not transparently programmed.

The OTP controller operates on the AHB system clock. It takes care of the timing requirements of the various OTP cell operations using system clock tick values in configurable registers. The actual accesses to the OTP cell are performed at no more than 20 MHz, with the controller making sure this frequency constraint is always respected.

Features

- Implements all timing constraints for any access to the physical memory cell in a configurable manner
- Automatic Error Code Correction (ECC) – 6 bits (implemented by the OTP cell)
- 32-bits read in a single clock cycle from the OTP cell
- Single word buffer for programming. No burst programming supported
- Empty words are 0xFFFFFFFF. Zeros are programmed per 32-bit word

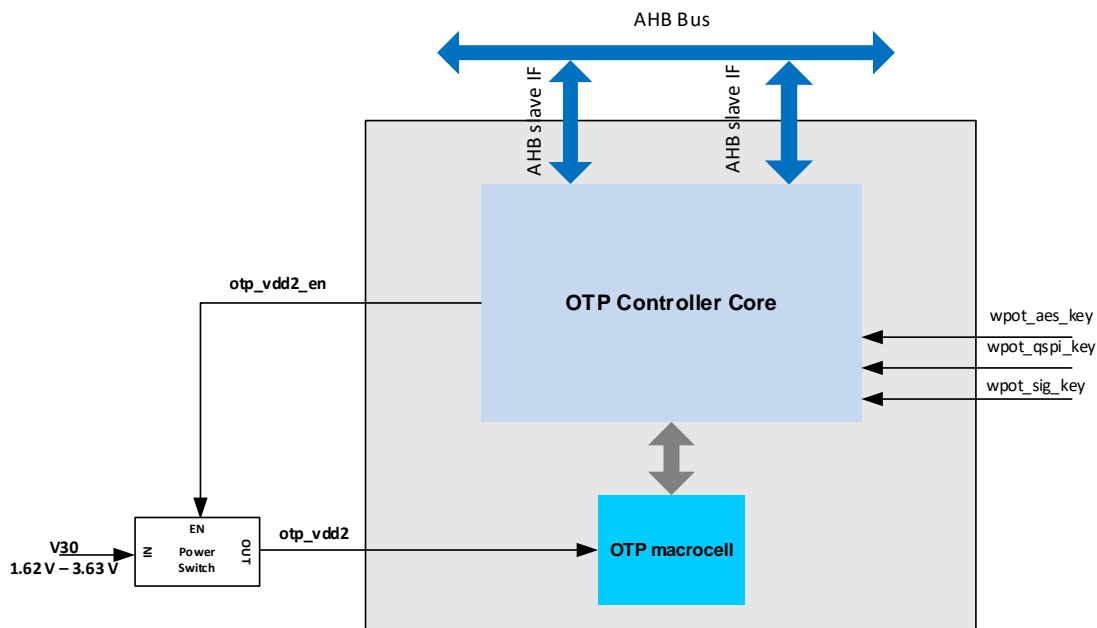

Figure 39. OTP controller block diagram

18.2 Architecture

The OTP controller block includes the OTP macro-cell and pure digital logic implementing the controlling functions. The OTP memory communicates with the controller, through a proprietary interface.

A power switch is used to control the power of the OTP cell driven by the digital logic.

The internal organization of the OTP cell is 32 bits data + 6 bits ECC for each of the 1024 addressable positions. The 6 bits of the ECC are not accessible outside of the OTP cell. The ECC is generated during the programming by the OTP cell, and is used during the reading again by the OTP cell, with a transparent way.

The system supplies three signals that enables write protection of three address ranges in the OTP memory. This protection prevents three specific address ranges of the OTP memory from being programmed. The request

comes from three interface signals. The three address ranges (in byte address) and their corresponding interface signal that enables protection are:

- Range1: 0x0B00 – 0x0BFF, is protected when PROT_QSPI_KEY_WRITE is asserted
- Range2: 0x0A00 – 0x0AFF, is protected when PROT_AES_KEY_WRITE is asserted
- Range3: 0x08C0 – 0x09BF, is protected when PROT_SIG_KEY_WRITE is asserted

These three address ranges host various encryption keys in the OTP cell: The encryption key of the AES algorithm in the QSPIC, the encryption key for the general-purpose AES engine and the signature public key.

The OTP controller configures the OTP cell to be in one of the following modes:

- **Power Down mode (PDOWN).** In this mode of operation, the OTP cell is not powered by the VDD2 pin and the internal LDO is inactive. The otp_vdd2_en signal is 0 and the otp_vdd2 should be at 0 V. In this mode, the OTP cell consumes the least possible power, while the system is in active power state
- **Deep Standby mode (DSTBY).** In this mode, the required power supplies are applied to the OTP cell. However, the internal LDO of the OTP cell is inactive. The otp_vdd2_en signal is 1 and the otp_vdd2 should be at a functional voltage level (the VDD2 of the OTP cell is powered)
- **Standby mode (STBY).** In this mode, the OTP cell is disabled by deactivating the chip select signal. The OTP cell is powered and the internal LDO is enabled. The power consumption of the OTP cell is not the lowest possible but is less than the power consumption in active mode. This is the state from which any active mode of operation (READ, PROG, PVFY, RINI) happens with the least delay
- **Read mode (RD).** In this mode, the contents of the OTP cell are read at the respective AHB address space. This mode can be used for software execution in place (XIP). The OTP controller translates a read request into the corresponding control sequence for the OTP cell, to retrieve the requested data
- **Programming mode (PROG).** The PROG mode provides the functionality for programming a 32-bit word into an OTP position. The OTP cell expands the 32-bit word by calculating and automatically appending a 6-bit checksum (ECC). Note that, there is no way to access these extra 6-bits of the ECC information. Programming is performed only for bits equal to 0. Bits that are equal to 1 are bypassed to save on programming time. Because the ECC value is unknown to the controller, there are always 6 extra programming pulses applied for the ECC bits. Programming is done by issuing a programming request stored in the Programming Buffer (PBUF). PBUF consists of 2 configuration registers storing the 32-bit data value and the 10-bit address in the OTP cell where the value should be programmed. A new request can only be stored in PBUF when the previous is served. A status bit indicates if this has already been done, and should therefore be monitored by SW before issuing a new programming request
- **Programming Verification mode (PVFY).** The PVFY mode forces the OTP cell to enter in a special margin read mode. This mode is used to verify the content of the OTP positions that have been programmed using the PROG mode and that the programmed data will be retrieved correctly under all the corner cases. When this mode is used, the contents of the OTP cell can be read, at the respective AHB address space. The CPU must read all OTP positions that have been programmed by accessing the corresponding addresses and verify that all the retrieved words are equal to the expected values.
- **Read Initial State mode (RINI).** The RINI mode implements a production test of the initial margin read, which should be performed in the OTP cell, before the first programming will be applied. This test verifies that the OTP cell is empty (all the bits are equal to 1). The OTP controller will send to the OTP cell the required control sequence to enables the test mode. Following that, the CPU should read all the content of the OTP cell at the respective AHB address space and verify that all the retrieved words are equal to 0xFFFFFFFF. This specific read mode is a margin read, which mean that is not equivalent with the normal read and should only be used for this purpose

18.3 Programming

There is a simple sequence of steps that needs to be followed to configure the OTP Controller:

1. Enable clock for OTP controller by setting the CLK_AMBA_REG[OTP_ENABLE] bit.
2. Put the OTP in standby mode (OTPC_MODE_REG[OTPC_MODE_MODE] = 0x2).
3. Wait OTP mode to change (OTPC_STAT_REG[OTPC_STAT_MRDY] = 1).
4. Set OTP speed by writing:
 - a. OTPC_TIM1_REG =:
 - i. hclk = 16 MHz: 0x0999000F.

- ii. hclk = 32 MHz: 0x0999101F (default).
 - iii. hclk = 48 MHz: 0x0999202F.
 - iv. hclk = 96 MHz: 0x0999515F.
 - b. OTPC_TIM2_REG = 0xA4040409.
5. Perform an OTP access:
- a. Programming:
 - i. Set up OTP write mode (OTPC_MODE_REG[OTPC_MODE_MODE] = 0x4).
 - ii. Wait OTP mode to change (OTPC_STAT_REG[OTPC_STAT_MRDY] = 1).
 - iii. Check OTPC_STAT_REG[OTPC_STAT_PBUF_EMPTY] = 1
 - iv. Write OTPC_PWORD_REG the data to be programmed.
 - v. Write OTPC_PADDR_REG the address that the data will be programmed to.
 - vi. Wait until the programming is finished (OTPC_STAT_REG[OTPC_STAT_PRDY] = 1).
 - vii. Switch to OTP verify mode (OTPC_MODE_REG[OTPC_MODE_MODE] = 0x5).
 - viii. Wait OTP mode to change (OTPC_STAT_REG[OTPC_STAT_MRDY] = 1).
 - ix. Read back and compare the data written.
 - x. Put the OTP in standby mode (OTPC_MODE_REG[OTPC_MODE_MODE] = 0x2).
 - xi. Wait OTP mode to change (OTPC_STAT_REG[OTPC_STAT_MRDY] = 1).
 - b. Reading:
 - i. Set up OTP read mode (OTPC_MODE_REG[OTPC_MODE_MODE] = 0x3).
 - ii. Wait OTP mode to change (OTPC_STAT_REG[OTPC_STAT_MRDY] = 1).
 - iii. Read OTP word.
 - iv. Put the OTP in standby mode (OTPC_MODE_REG[OTPC_MODE_MODE] = 0x2).
 - v. Wait OTP mode to change (OTPC_STAT_REG[OTPC_STAT_MRDY] = 1).

NOTE
When VDD = 0.9 V (POWER_CTRL_REG[VDD_LEVEL] = 0x0) and hclk = 32 MHz, OTPC_TIM1_REG[OTPC_TIM1_CC_T_RD] should be equal to 2.

19. Quad SPI Flash Controller

Device:	DA14691	DA14695	DA14697	DA14699
Feature Availability:	✓	✓	✓	✓

19.1 Introduction

The Quad SPI Controller (QSPIC) provides a low pin count interface to flash memory devices. The QSPIC supports the standard Serial Peripheral Interface (SPI) and a high performance Dual/Quad SPI Interface. The QSPIC gives the ability to read data from a quad flash memory, transparently through the SPI bus. This Execute-In-Place (XIP) feature combined with the CPU cache, provides comparable performance to executing code from standard parallel flash. In this case the QSPIC generates all the control signals for the SPI bus that are needed to read data from the serial flash memory. Additionally, software can easily control the serial flash memory through a memory mapped register file which is contained in the QSPIC. All instructions supported by the Flash memory, can be programmed using the above register file. A special feature of the QSPIC enables for automated re-initialization of the flash device right after power up, without the CPU being involved, thus reducing initialization time and consequently power dissipation. A small initialization memory of sixteen 32-bit retainable words, contains an encoded sequence of commands which are shifted into the flash memory right after waking up from Power down modes.

Features

- SPI Modes:
 - Single: Data transfer via two unidirectional pins
 - Dual: Data transfer via two bidirectional pins
 - Quad: Data transfer via four bidirectional pins
- Auto Mode: up-to 32 Mbyte transparent Code access for XIP (Execute-In-Place) and Data access with 3-byte and 4-byte addressing modes
- Manual Mode: Direct register access using the QSPIC register file
- Up to 96 MHz QSPI clock. Clock modes 0 and 3. Master mode only
- Vendor independent Instruction Sequencer
- Support for single access and high-performance burst mode, in combination with the cache controller (in Auto Mode)
- Use of a special read instruction in the case of a specific (programmable) wrapping burst access
- Erase suspend/resume to Support for Code and Data storage
- Hardware initialization state machine based on uCode commands
- Decrypt on-the-fly (AES-256b-CTR) capability while in Auto mode operation

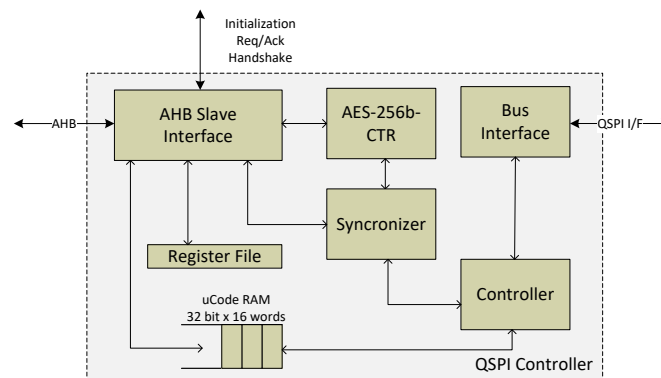

Figure 40. QSPI flash controller block diagram

19.2 Architecture

The AHB slave block implements two AHB Slave interfaces which enable access to the register file and the uCode memory. The Controller implements all protocol related to the functionality of the FLASH memory. It contains a finite state machine (FSM) that generates all necessary signaling to the QSPI bus and realizes all features of the Auto mode operation. Moreover, it manages all data transfers between the two interfaces (the AHB and the QSPI).

The Bus Interface block controls the QSPI signals at the lowest level while the Synchronizer implements "stretching" or "shortening" of the signals that cross the two clock domains.

The uCode memory is sixteen words x 32 bits. It contains the microcode for the initialization of the FLASH memory even before the CPU has been waken up. The signaling between the FIFO and the PMU is done through the request/acknowledge signals.

19.2.1 Interface

The Quad SPI Controller uses the following signals:

- QSPI_SCK: output serial clock
- QSPI_CS: Active Low output Chip select
- QSPI_IO0:
 - DO (output) in Single SPI mode
 - IO0 (bidirectional) in Dual/Quad SPI mode
- QSPI_IO1:
 - DI (input) in Standard SPI mode
 - IO1 (bidirectional) in Dual/Quad SPI mode
- QSPI_IO2:
 - General purpose (output) (e.g. WPn Write Protect) in Standard SPI mode
 - IO2 (bidirectional) in Quad SPI mode
- QSPI_IO3:
 - General purpose (output) (e.g. HOLDn) in Single SPI mode
 - IO3 (bidirectional) at Quad SPI mode
- The output drive of the pads is programmable via register bits QSPI_GP_REG[QSPI_PADS_DRV] and slew via QSPI_GP_REG[QSPI_PADS_SLEW]

The Quad SPI Controller (QSPIC) drives all data pins constantly except for the case when a read is performed. The time for changing the direction of the pads is at least 1.5 x QSPI_CLK (QSPI_CLK being the clock that the FLASH operates on). In this way, data lines are always terminated thus reducing unnecessary power consumption.

The default state of the QSPI_IOx pins is 1. This state is applied at the pins as soon as the QSPIC clock is enabled even if no access to the external FLASH has yet been triggered. The value of the pins might be changed by programming the respective registers (QSPIC_IOx_DAT, QSPIC_IOx_OEN). This value will be valid only after the QSPI_CS is pulled low, i.e. an access to the external FLASH occurs.

19.2.2 Initialization FSM

Since the QSPIC is used in an ultra-low-power SoC, it is possible that the FLASH memory will be either totally powered off, or set into deep power-down mode when the system goes to any of the sleep modes.

However, upon power-up or wake-up, the FLASH device requires a few commands to get at a state where the CPU can execute code from. This initialization should be done prior to the CPU wake-up. The QSPIC contains a hardware state machine, which decodes a few commands in a sixteen 32-bit word retainable FIFO and initializes the FLASH automatically, even before the CPU is waken up.

The command FIFO is initialized in cold boot of the system by the CPU with the commands residing in the flash header. The start address of the RAM to be programmed with the uCode is 0x38000040. The command encoding is presented in [Table 95](#).

Table 95: Initialization command encoding

Bit	Name	Description
Byte 0		
7:3	CMD_NBYTES	The number of payload bytes to be sent
2:1	CMD_TX_MD	QSPI bus mode when transmitting the command: 0x0: single SPI 0x1: Dual SPI 0x2: Quad SPI 0x3: Reserved
0	CMD_VALID	1: the command record is valid 0: the command record is not valid
Byte 1		
7:0	CMD_WT_CNT_LS	Number of clock cycles to wait after applying the command (least significant byte)
Byte 2		
7:0	CMD_WT_CNT_MS	Number of clock cycles to wait after applying the command (most significant byte)
Byte 3 to (CMD_NBYTES+2)		
		The actual data bytes to be sent within a CS envelope

The first byte (LSByte) in the word of the FIFO contains the flag of the command being valid or not, the bus mode of operation and the number of bytes contained in the payload to be sent. The second and third byte define the amount of clock cycles that the QSPIC must wait, after applying the command. The clock to be used is the RC32M (~32 MHz), which results in a maximum of 4 ms waiting time. If more time is required by the flash, then multiple identical commands might be issued.

Example:

Considering 0xAB to be the opcode for releasing the flash from deep power-down mode, the FIFO would be initialized with the following sequence:

Table 96: Flash initialization uCode example

Byte	Value	Description
0	0x11	Valid command record, single SPI mode, 2 B of payload
1	0x01	1 clock cycle wait after command is sent
2	0x00	
3	0xAB	Actual flash command opcode

19.2.3 SPI Modes

The Quad SPI Controller (QSPIC) supports the following SPI standards:

- Single: Data transfer via two unidirectional pins. The QSPIC supports communication to any single/dual or Quad SPI FLASH memory. However, the Single SPI interface does not support bus modes 1 and 2, full-duplex communication and any SPI Slave mode
- Dual: Data transfer via two bidirectional pins
- Quad: Data transfer via four bidirectional pins

19.2.4 Access Modes

The access to a serial FLASH connected to the QSPI can be done in two modes:

- Auto mode
- Manual mode

These modes are mutually exclusive. The serial FLASH can operate only in one of the two modes. In auto mode, 3-bytes and 4-bytes addressing modes are supported. With QSPIC_CTRLMODE_REG[QSPIC_USE_32BA]=0,

up to 16 MB QSPI (3-bytes addressing) can be accessed. If QSPIC_USE_32BA=1, 4-bytes addressing is enabled for accessing up to 32 Mbyte QSPI flash.

Auto mode

In auto mode, a read access from the serial flash memory is fully transparent to the CPU. A read access at the interface is translated by the QSPIC into the respective SPI bus control commands needed for the flash memory access. When the Auto mode is disabled, any access (reading or writing) will be ignored. When the Auto mode is enabled, only read access is supported. A write access causes hard fault. A read access can be single access, incremental burst or wrapping burst. Wrapping burst is supported even when the flash device doesn't support any special instruction for wrapping burst. A special read instruction can be used in the case of a specific (programmable) wrapping burst access. When a flash supports a special instruction for wrapping burst access, it reduces access time (less wait states). For maximizing the utilization of the bus and minimizing the number of wait states, it is recommended to use burst accesses. However, non-sequential random accesses are supported with cost of more wait states.

Manual Mode

In manual mode the FLASH memory is controlled via a register file. All instructions that are supported by a FLASH memory can be programmed using the register file. Moreover, the mode of interface (SPI, Dual SPI, Quad SPI) and the mode of operation (Auto or Manual Mode) can be configured via this register file. The register file supports the following data sizes for reading and writing accesses: 8 bits, 16 bits, and 32 bits.

19.2.5 Endianness

The QSPIC operates in little-endian mode. For 32-bit or 16-bit access (for read and write operations) to a serial FLASH memory, the least-significant byte comes first. For 32-bit access, the byte ordering is: data [7:0], data [15:8], data [23:16], data [31:24] while for 16-bit access the byte ordering is: data [7:0], data [15:8].

19.2.6 Erase Suspend/Resume

The QSPI flash can be used for Data Storage, combining the EEPROM functionality + Program storage in one single device. For this purpose, the QSPI ERASE/SUSPEND ERASE/RESUME commands are automatically executed as shown in [Figure 41](#).

To store data in QSPI FLASH, execution from QSPI must temporary be stopped by running directly from RAM or from a cached program part. The sector selected for storage must be erased first, in case it contained data already. The process is implemented in a HW FSM and consists of the following steps:

1. The controller is in Auto mode and read requests are served. The Erase procedure is initiated by setting QSPIC_ERASE_EN=1. The address of the sector that will be erased is defined at QSPIC_ERS_ADDR. When an Erase procedure is requested, the controller jumps to state 2.
2. Read requests are still served. As soon as the Read requests stop (also possible due to late bus master change, for example, DMA) and there is no any new Read request for a few AHB clock cycles equal to QSPIC_ERSRES_HLD, then QSPIC_WEN_INST and QSPIC_ERS_INST instructions are sent to the FLASH. The QSPIC_RESSUS_DLY counter is started and the controller jumps to state 3.
3. Erasing is in progress in flash and the QSPI controller waits until one of the following events occur:
 - a. A status check request. This request can be forced by writing SPIC_CHKERASE_REG. The QSPI controller will then read the status of the FLASH memory and check if erasing has finished. Reading of the status is delayed by QSPIC_RESSTS_DLY cycles or by QSPIC_RESSUS_DLY cycles. The first is based on the clock of the SPI bus, while the latter on an internal 222 KHz clock. The selection between the two delays is configured by QSPIC_STSDLY_SEL bit. If erasing has finished, the QSPI controller returns to the normal operation (state 1) and sets QSPIC_ERASE_EN= 0, otherwise it remains at state 3.
 - b. A flash read data request on the AHB bus. The QSPI controller reads the status of the FLASH memory and checks if erasing is done. The reading of the status will be delayed again as in the previous case by QSPIC_RESSTS_DLY or QSPIC_RESSUS_DLY. If erasing has ended, the controller returns to normal operation (state 1) and sets QSPIC_ERASE_EN= 0. The read request will be served as soon as the controller reaches state 1. If erasing has not ended, the controller proceeds to state 4.
4. The QSPIC_SUS_INST is sent as soon as the QSPIC_RESSUS_DLY/QSPIC_RESSTS_DLY counter is 0. The controller jumps to state 5.

5. The controller polls the FLASH status register, until the FLASH device becomes ready (erasing is suspended). The controller will then proceed to state 6.
6. The erasing process in the FLASH is now suspended and the controller may read the FLASH. The requested data are retrieved from the FLASH device. If the reading on the AHB stops, (for example, Cache hit), and there are no new Read requests for a number of AHB clock cycles equal to QSPIC_ERSRES_HLD, the controller goes to state 7.
7. The QSPIC_RES_INST instruction is applied, and the controller jumps back to state 3. Also, the QSPIC_RESSUS_DLY counter is started. As a result, the erase procedure is resumed.

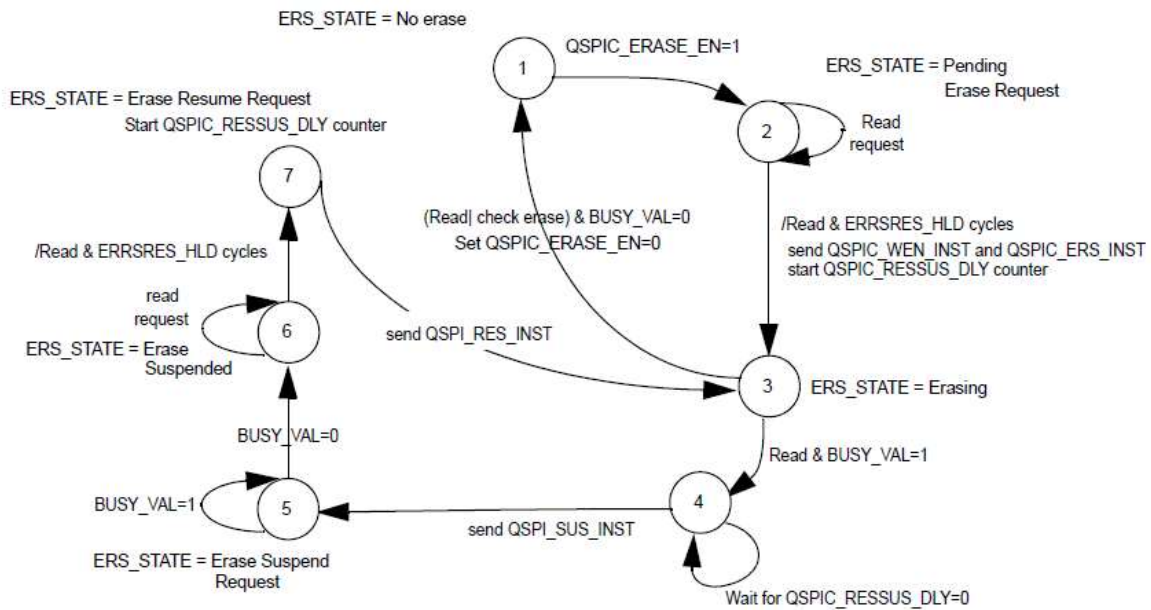

Figure 41. Erase suspend/resume in Auto mode

QSPIC_RESSTS_DLY counts QSPI_CLK cycles, so before changing the QSPI_CLK, make sure that QSPIC_RESSTS_DLY is set large enough to meet the timing parameter requirements of the flash device used.

19.2.7 On-the-fly Decryption

The QSPIC supports decryption of the data retrieved from the flash device, only when in Auto mode. Flash contents should be encrypted already, using the same algorithm.

The address range that will be decrypted automatically by the controller, is defined in the QSPIC by using two configuration registers, one for the start address (ENC_START_ADDR), and one for the end address (ENC_END_ADDR). The defined address range is 1024 B aligned. All addresses that are outside of this range, will not be automatically decrypted, but fetched as is.

The on-the-fly decryption feature is based on the CTR mode of the AES encryption algorithm. The AES algorithm processes blocks of 128 bits. That means that the input and the output block of the AES is 128 bits or 16 bytes and as a result, data to be processed by the algorithm, are fragmented into blocks of 16 B. The key size that is used for the AES algorithm is 256 bits.

For the AES-256-CTR algorithm, only the cipher part of the AES algorithm is required. The general idea of the encryption process is based on the encryption of a 128-bit counter block (CTR). The initial value of the CTR is labeled as CTR0. The first counter block (CTR0) is encrypted with the help of the AES cipher, and the encrypted result is XORed with the first 16 B of the plaintext data (P0) to be encrypted. The counter block is incremented by one (CTR1 = CTR0 + 1) and is encrypted again. The result is XORed, with the next 16 B of the plaintext (P1), and so on, until all plaintext data are encrypted.

The AES CTR decryption is the same process as the encryption. By XORing again the ciphertext with the same encrypted counter value, the plaintext is retrieved. The decryption process can be described by equations as below:

For $j=1$ to m , do $CTR_j = CTR_{j-1} + 1$

For $j=0$ to m , do $P_j' = \text{AES_CIPH}_k(\text{CTR}_j) \oplus C_j$

Because accesses to the FLASH memory are random, the structure of the CTR block is selected to simplify the process. The total size of the counter block is 128 bits or 16 bytes namely: $\text{CTRB}_0, \text{CTRB}_1, \text{CTRB}_2, \text{CTRB}_3, \dots, \text{CTRB}_{14}, \text{CTRB}_{15}$.

The first 8 B ($\text{CTRB}_0 - \text{CTRB}_7$) of the counter block comprise the NONCE value and are programmed in the QSPI Controller in configuration registers. This is typically a random value and is the same for all the CTR_i blocks.

The next 4 B of the counter block ($\text{CTRB}_8 - \text{CTRB}_{11}$) are always zero.

The last 4 B of the counter block ($\text{CTRB}_{12} - \text{CTRB}_{15}$), are produced automatically by the hardware, based on the 32-bit address offset $\text{OFFSET_ADDR}[31:0]$ inside the encrypted range, where the data that should be decrypted are placed. If $\text{FLASH_ADDR}[31:0]$ is the absolute address of a specific byte inside the encrypted range, the offset address is $\text{OFFSET_ADDR} = \text{FLASH_ADDR} - \text{ENC_START_ADDR}$. The four least significant bits of the address offset are truncated and the four most significant bits of the CTRB_{12} are padded with zeros. Thus, the zero value in bytes $\text{CTRB}_{12} - \text{CTRB}_{15}$ of the CTR is used for the first 16 bytes of the address range that is encrypted, the value 1 is used for the second 16 B of the address range and so on.

The final form of the counter block is the following:

{64 bits NONCE, 32 bits 0x0, 4 bits 0x0, $\text{OFFSET_ADDR}[31:4]$ }

The four least significant bits of the address offset $\text{OFFSET_ADDR}[3:0]$ define which of the $\text{AES_CIPH}_k(\text{CTR}_i)$ byte should be used for the decryption of a specific byte of the encrypted block C_i .

In this way the CTR block that should be used for the decryption of a specific byte, can be calculated immediately by the address of the byte in the FLASH and the start address of the encrypted range. This counter block supports up to 4 GB data, which covers the maximum supported size for the flash devices.

19.2.8 Timing

This section contains timing diagrams for input and output signals

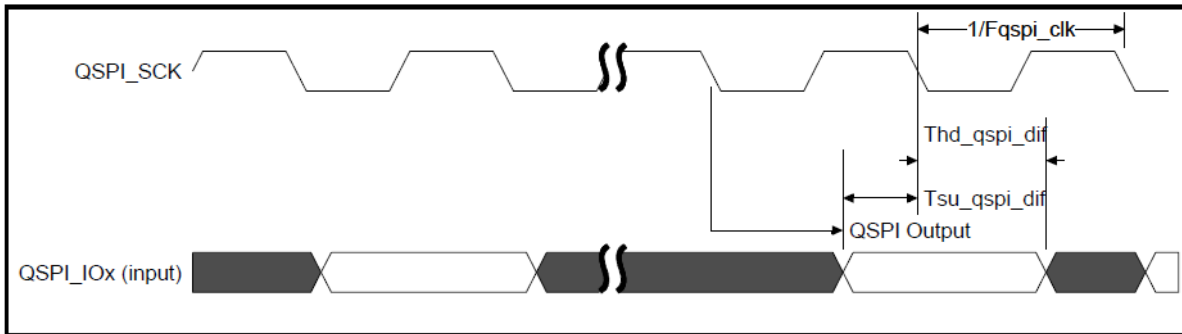

Figure 42. QSPI input timing

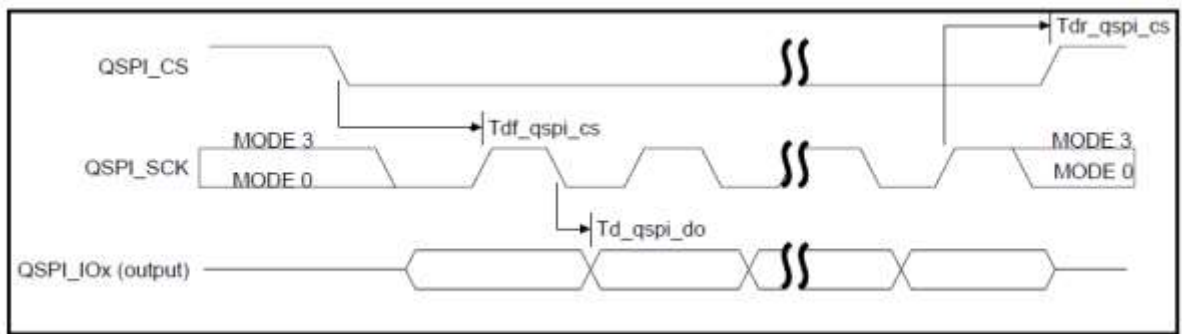

Figure 43: QSPI output timing

Table 97: QSPI timing parameters

Parameter	Description	Conditions	Min	Typ	Max	Units
Fqspi_sck	QSPI_SCK frequency				96	MHz
Td_qspi_do	Delay QSPI_SCK to QSPI_I/Ox		-1.4		3	ns
Tdr_qspi_cs	Delay QSPI_SCK to QSPI_CS	$T_{qspi_sck}=1/F_{qspi_sck}$	T_{qspi_sck} - 2.5		T_{qspi_sck} +2.0	Ns
Tdf_qspi_cs	Delay QSPI_CS to QSPI_SCK	$T_{qspi_sck}=1/F_{qspi_sck}$	T_{qspi_sck} - 2.5		T_{qspi_sck} +3.5	ns
Tsu_qspi_dif	Setup time QSPI_IO to QSPI_SCK falling edge with variable readpipe sample clock delay QSPI_RPIPE_EN=1	QSPIC_PCLK_MD=6	2.6			ns
Thd_qspi_dif	Hold time QSPI_SCK falling edge to QSPI_IO with variable readpipe sample clock delay QSPI_RPIPE_EN=1	QSPIC_PCLK_MD=6	-0.3			ns

Note 1 Total Delay QSPI FLASH output + PCB delay + $T_{su_qspi_dif} < 1/F_{qspi_sck}$. E.g Winbond output + PCB delay = 6ns, -> $T_{su_qspi_dif} < 1/96 \text{ MHz} - 7 = 3.41$ -> QSPI_PCLK_MD= 6, QSPI_RPIPE_EN=1 is recommended value for all QSPI_SCK frequencies and shall be set before the maximum frequency is applied.

19.3 Programming

19.3.1 Auto Mode

In the case of Auto mode of operation, the QSPIC generates a sequence of control signals in SPI BUS. This sequence of control signals is analyzed to the following phases: instruction phase, address phase, extra byte phase, dummy clocks phase, and read data phase. These phases can be programmed via registers:

- QSPIC_BURSTCMDA_REG
- QSPIC_BURSTCMDDB_REG

Bits QSPIC_INST are used to set the selected instruction for the cases of incremental burst or single read access. If bit QSPIC_WRAP_MD is equal to 1, bit QSPIC_INST_WB can be used to set the used instruction for the case of a wrapping burst read access of length and size described by the bits QSPIC_WRAP_LEN and QSPIC_WRAP_SIZE respectively. In all other cases the QSPIC_INST is the selected instruction.

If the instruction must be transmitted only in the first access after the selection of Auto Mode, then the QSPIC_INST_MD must be equal to 1.

To enable the extra byte phase set QSPIC_EXT_BYTE_EN=1 register. The transmitted byte during the extra byte phase is specified by the QSPIC_EXT_BYTE register. To disable (hi-Z) the output pads during the transmission of bits [3:0] of extra byte, set QSPIC_EXT_HF_DS =1.

The number of dummy bytes during the dummy clocks phase is specified by register QSPIC_DMY_NUM and enabled by QSPIC_DMY_FORCE.

The SPI BUS mode during each phase can be set with register bits:

- QSPIC_INST_TX_MD for the instruction phase
- QSPIC_ADR_TX_MD for the address phase
- QSPIC_EXT_TX_MD for the extra byte phase
- QSPIC_DMY_TX_MD for the dummy byte phase
- QSPIC_DAT_RX_MD for the read data phase

If the Quad SPI mode is selected in any of the above phases, write 0 to the QSPIC_IO3_OEN and QSPIC_IO2_OEN.

If the FLASH Memory needs to be accessed with any instruction but the read instruction, then the Manual Mode must be used.

The final step to enable the use of Auto Mode of operation, is to set QSPIC_AUTO_MD equal to 1.

19.3.2 Manual Mode

For the Manual mode QSPIC_AUTO_MD must be equal to zero. Manual operation of the bus signals is done via QSPIC_CTRLBUS_REG:

- The start/end of an access can be controlled using bits QSPIC_EN_CS and QSPIC_DIS_CS respectively
- The SPI bus mode of operation can be configured with bits QSPIC_SET_SINGLE, QSPIC_SET_DUAL and QSPIC_SET_QUAD

Writing to QSPIC_WRITEDATA register, is generating a data transfer from the QSPIC to the SPI bus. A read access at QSPIC_READDATA register, is generating a data transfer from the SPI bus.

Writing to QSPIC_DUMMYDATA register, is generating a few dummy clock pulses to the SPI bus.

When access to the SPI bus via QSPIC_WRITEDATA, QSPIC_READDATA and QSPIC_DUMMYDATA is very slow, most probably the delay in accessing the internal AHB is large. In this case, set the QSPIC_HRDY_MD register equal to 1 to increase priority when accessing the required registers. All masters of the SoC can access the AHB bus interface without waiting for the SPI Bus access completion. Polling of the QSPIC_BUSY register must be done to check the end of the activity at the SPI bus, before issuing any more accesses. If a read transaction is finished, QSPIC_RECVDATA contains the received data.

The state and the value of the QSPI_IO[3:2] is specified by the following registers bits:

- QSPIC_IO3_OEN, QSPIC_IO3_DAT (Used for the WPn, Write Protect function)
- QSPIC_IO2_OEN, QSPIC_IO2_DAT respectively (Used for the HOLDn function)

19.3.3 Clock Selection

The SPI clock mode as set with bit QSPIC_CLK_MD The supported modes for the generated SPI clock is:

- 0 = Mode 0. The QSPI_SCK is low, when the bus is idle (QSPI_CS is high)
- 1 = Mode 3. The QSPI_SCK is high, when the bus is idle (QSPI_CS is high)

The QSPI_CLK frequency has a programmable divider CLK_AMBA_REG[QSPI_DIV] which divides either XTAL32 or PLL by 1,2,4,8.

The QSPI_CLK can be faster or slower than HCLK.

19.3.4 Receiving Data

The standard method to sample received data, is by using the positive edge of the QSPI_SCK. However, when the output delay of the FLASH memory is high, a timing problem on the read path is very likely. For this reason, the QSPIC can be programmed to sample the received data with the negative edge of the QSPI_SCK. This is configured with the QSPIC_RXD_NEG register.

Furthermore, the receive data can be pipelined by setting QSPI_RPIPE_EN=1 and the sampling clock can be delayed using QSPI_PCLK_MD. This enables sampling the received data later than the actual clock edge allows.

19.3.5 Delay Line Configuration

When VDD = 0.9 V (POWER_CTRL_REG[VDD_LEVEL] = 0x0) and QSPI_CLK = 32 MHz, the QSPIC_CTRLMODE_REG[QSPIC_PCLK_MD] bit field should be equal to 2. On the contrary, if VDD = 1.2 V then QSPIC_CTRLMODE_REG[QSPIC_PCLK_MD] bit field should be equal to 7.

20. Quad SPI RAM/Flash Controller

Device:	DA14691	DA14695	DA14697	DA14699
Feature Availability:	x	✓	✓	✓

20.1 Introduction

The Quad SPI Controller (QSPIC2) provides a low pin count interface to serial QSPI Flash and RAM memory devices. The QSPIC2 supports the standard Serial Peripheral Interface (SPI) and a high performance Dual/Quad SPI Interface. The QSPI RAM feature provides a low-cost RAM extension for infrequently used data.

The QSPIC2 automatically generates all the control signals for the QSPI bus needed to access data from the serial quad memory. The controller has a vendor independent register file that provides a rich set of control fields for wide range of Flash and RAMs.

The QSPIC2 provides transparent memory mapped RAM access.

Features

- SPI modes:
 - Single: Data transfer through two unidirectional pins
 - Dual: Data transfer through two bidirectional pins
 - Quad: Data transfer through four bidirectional pins
- Auto mode: up-to 32 MB memory mapped Read/Write Data access with 3-byte and 4-byte addressing modes
- Manual mode: Direct register access using the QSPIC2 register file
- QSPI clock up-to 96 MHz. Clock modes 0 and 3. Master mode only
- Vendor independent Instruction Sequencer
- In Auto mode the flash control signals are fully programmable
- Use of a special read instruction in the case of a specific (programmable) wrapping burst access
- Erase suspend/resume to Support for Code and Data storage

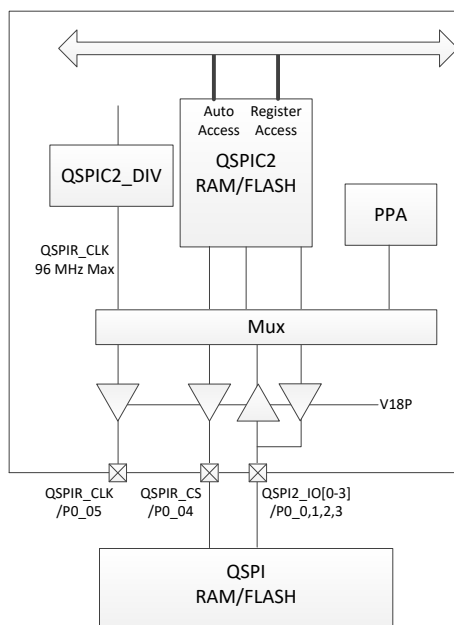

Figure 44. Quad SPI RAM/Flash controller

20.2 Architecture

20.2.1 Interface

- QSPI_SCK: output serial clock

- QSPI_CS: Active Low output Chip select
- QSPI_IO0:
 - DO (output) in Single SPI mode
 - IO0 (bidirectional) in Dual/Quad SPI mode
- QSPI_IO1:
 - DI (input) in Standard SPI mode
 - IO1 (bidirectional) in Dual/Quad SPI mode
- QSPI_IO2:
 - General purpose (output) (for example, WPn Write Protect) in Standard SPI mode
 - IO2 (bidirectional) in Quad SPI mode
- QSPI_IO3:
 - General purpose (output) (for example, HOLDn) in Single SPI mode
 - IO3 (bidirectional) at Quad SPI mode

20.2.2 SPI Modes

The Quad SPI Controller (QSPIC2) supports the following SPI standards:

- Single: Data transfer via two unidirectional pins. The QSPIC2 supports communication to any single/dual or Quad SPI FLASH memory. In contradiction to the Standard SPI interface, the supported Single SPI interface does not support the bus modes 1 and 2, does not support full-duplex communications and does not support any SPI Slave mode
- Dual: Data transfer through two bidirectional pins
- Quad: Data transfer through four bidirectional pins

20.2.3 Access Modes

Access to a serial memory (flash or RAM) connected to the QSPIC2 can be done in two modes:

- Auto mode
- Manual mode

These modes are mutually exclusive. The serial memory can be controlled only in one of the two modes. The registers which control the mode of operation can be used at any time.

In Auto mode, 3-byte and 4-byte addressing modes are supported. With QSPIC2_USE_32BA = 0, up to 16 MB serial memory (3-byte addressing) can be accessed. If QSPIC2_USE_32BA = 1, the 4-byte addressing is enabled for accessing up to 32 MB serial memory.

Auto Mode Flash Access

In auto mode (QSPIC2_AUTO_MD=1), the read access to a serial flash memory is performed in a fully transparent way through the SPI bus. A read access to the memory space, where the external memory is mapped, is translated by the controller to the respective SPI bus command sequence, which is needed for the retrieving of the requested data from the serial flash memory.

When the auto mode is disabled (QSPIC2_AUTO_MD = 0), any access (reading or writing) to the mapped memory space is ignored by the controller.

Only read accesses are supported when the connected external device is a FLASH memory (QSPIC2_SRAM_EN = 0). A write access causes a hard fault at the CPU.

The read access can be single access or incremental burst or wrapping burst access. The wrapping burst is supported even when the controlled serial flash does not support any special instruction for wrapping burst. A special read instruction can be used in the case of a specific (programmable) wrapping burst access. When a serial flash supports a special instruction for wrapping burst access, this feature saves access time (less wait states). For maximizing the utilization of the bus and minimizing the number of wait states, it is recommended to be used burst accesses. However, non-sequential random accesses are supported with the cost of more wait states.

Auto Mode RAM Access

In the case where it is connected to a serial RAM device, the QSPIC2 controller is capable of provide read/write functionality.

The special configuration register must be programmed to enable the RAM functionality (QSPIC2_SRAM_EN = 1). As in the case where the external device is a FLASH, the auto mode must also be enabled (QSPIC2_AUTO_MD = 1). In the case where the auto mode is disabled (QSPIC2_AUTO_MD = 0), any access (reading or writing) in the memory space, where the external device has been mapped, is ignored by the QSPI controller.

The read access in the memory space of the external serial RAM memory, is done in a fully transparent way through the QSPI bus. The capability of the controller to handle the various types of read accesses, is the same as in the case of the FLASH device. Single access, incremental burst or wrapping burst are all supported.

A write access to the memory space where the external memory is mapped, does not cause a hard fault to the Cortex-M0. In the contrary, the write access is interpreted by the QSPIC2 in the respective QSPI bus protocol and the write data is stored in the external RAM device.

The controller is capable of handling write accesses of all kinds of burst: single access, incremental burst or wrapping burst access. The throughput that can be achieved, varies depending on the burst length, the word width, the cost of the protocol of the external memory device, and the frequency of the QSPI clock.

Burst accesses provides the highest throughput. The non-sequential random accesses are supported at the cost of more wait states. The maximum throughput that can be achieved, depends on the burst length.

Manual Mode

In Manual mode, the external serial memory is controlled via a register file. All instructions that are supported by the serial memory can be programmed by using the register file. Moreover, the mode of interface (SPI, Dual SPI, Quad SPI) and the mode of operation (Auto or Manual mode), can be configured via this register file. The register file supports the following data sizes for reading and writing accesses: 8-bits, 16-bits, and 32 bits.

20.2.4 Endianness

The QSPI controller operates in little-endian mode. For 32-bit or 16-bit access (for read and write operations) to a serial memory, the least-significant byte comes first. For 32-bit access, the byte ordering is: data [7:0], data [15:8], data [23:16], data [31:24] and for 16-bit access the byte ordering is: data [7:0], data [15:8].

20.2.5 Erase Suspend/Resume

A QSPI flash memory can be used for data storage, combining the EEPROM functionality + Program storage in one single device.

For this purpose, the QSPI ERASE/SUSPEND ERASE/RESUME are automatically executed as shown in Figure 45.

To store data in QSPI flash memory, the sector designated for storage must be erased first.

The ERASE/SUSPEND ERASE/RESUME process is only meaningful if the external device is a serial flash memory (QSPIC2_SRAM_EN = 0).

Erase procedure

1. The controller is in Auto mode and the read requests are served. The Erase procedure is initiated by setting QSPIC2_ERASE_EN=1. The address of the sector that is erased, is defined by the QSPIC2_ERS_ADDR. When an Erase procedure is requested, the controller enters in state 2.
2. The read requests are still served. As soon as the Read requests stop (also possible due to late bus master change, for example, DMA) and there is no new Read request for a number of AHB clock cycles equal to QSPIC2_ERSRES_HLD, the QSPIC2_WEN_INST and the QSPIC2_ERS_INST instructions, are sent to the QSPI FLASH. The QSPIC2_RESSUS_DLY counter is started. After this, the controller enters state 3.
3. The erasing is in progress in the QSPI FLASH memory. The QSPI controller waits for one of the following:
 - a. A status check request. This request can be forced by writing QSPIC2_CHKERASE_REG. This makes the QSPIC2 controller read the FLASH memory status and checks the end of *erasing*. Reading the status is delayed by QSPIC2_RESSTS_DLY cycles, or by QSPIC2_RESSUS_DLY cycles. The QSPIC2_RESSTS_DLY delay is based on the SPI bus clock, while the QSPIC2_RESSUS_DLY delay is based on a 288 kHz clock. The selection between the two delays, is configured with the help of the QSPIC2_STSDLY_SEL bit. After erasing, the QSPI controller returns to the normal operation (state 1) and sets QSPIC2_ERASE_EN= 0, otherwise it remains in state 3.
 - b. A read data request on the AHB bus. The QSPI controller reads the status of the FLASH memory and checks the end of erasing. Status reading is delayed again by QSPIC2_RESSTS_DLY cycles, or QSPIC2_RESSUS_DLY cycles. The QSPIC2_STSDLY_SEL bit does the Selection between two delays. At the end of erasing, the controller returns to normal operation (state 1) and sets QSPIC2_ERASE_EN = 0. The read request will be served in state 1. If the erasing has not ended, the controller proceeds to state 4.
4. The QSPIC2_SUS_INST is sent as soon as the QSPIC2_RESSUS_DLY counter is 0. The controller enters state 5.
5. The controller reads the status register until the FLASH device is ready (erasing is suspended). When the FLASH device is ready, the controller enters state 6.
6. Erasing process in the FLASH is suspended and the controller can read the FLASH. The requested data is retrieved from the FLASH device. If the reading on the AHB stops (for example, Cache hit) and there is no new Read request for a number of AHB clock cycles equal to QSPIC2_ERSRES_HLD, the controller enters state 7.
7. The QSPIC2_RES_INST instruction is applied and state 3 is entered. Also, the QSPIC2_RESSUS_DLY counter is started. The QSPIC2_RES_INST makes sure the erase procedure is continued (erase resume) in the flash device.

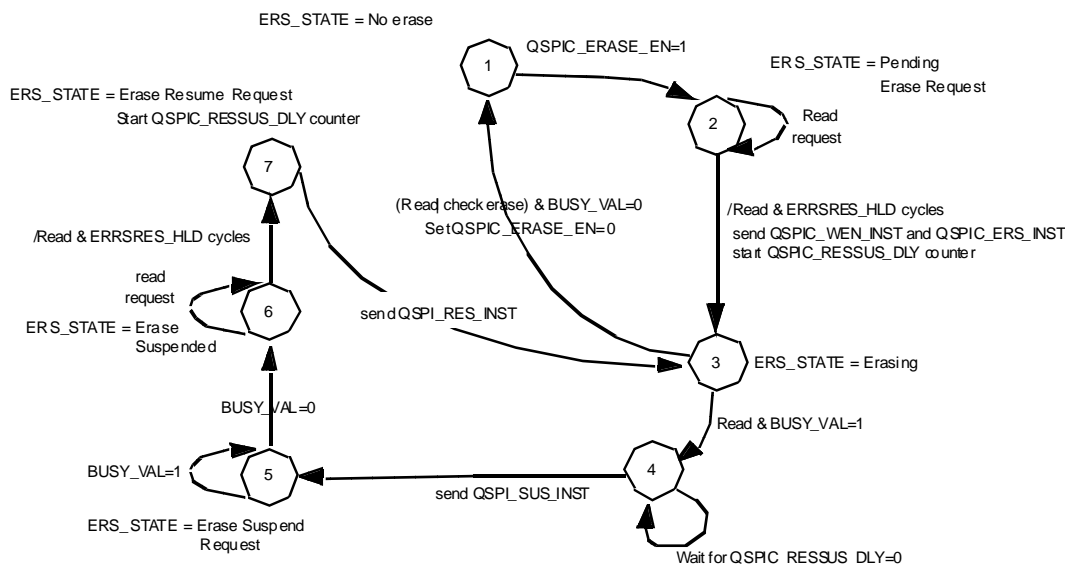

Figure 45. Erase suspend/resume in Auto mode

QSPI_RESSTS_DLY is counted with the QSPI_CLK, so before changing the QSPI_CLK, make sure that QSPI_RESSTS_DLY is set large enough to meet the timing parameter requirements.

QSPI Flash Programming procedure

Sectors are programmed in manual mode by polling the status bit in the QSPI flash. During programming, the CPU MUST run from shared or non-shared RAM. Also, interrupts must be disabled while executing the write command to the flash.

Byte programming is relatively short, so a polling loop could be acceptable to meet system latency requirements.

20.2.6 Low Power Considerations

To reduce the power dissipation in the QSPI flash, the QSPI_CLK must always be the highest possible system clock to keep the burst access to the flash as short as possible. The CPU must run as slow as possible for minimum power.

For lowest power with slow CPU (for example, 2 MHz) and high QSPI_CLK (for example, 32 MHz) bit QSPIC2_CTRLMODE_REG[QSPIC2_FORCENSEQ_EN] must be set to 1. This enables Split Burst mode, reducing the power dissipation during active burst only, while disabling the flash when the burst is done compared to high efficiency burst. These two modes are explained in the following two figures:

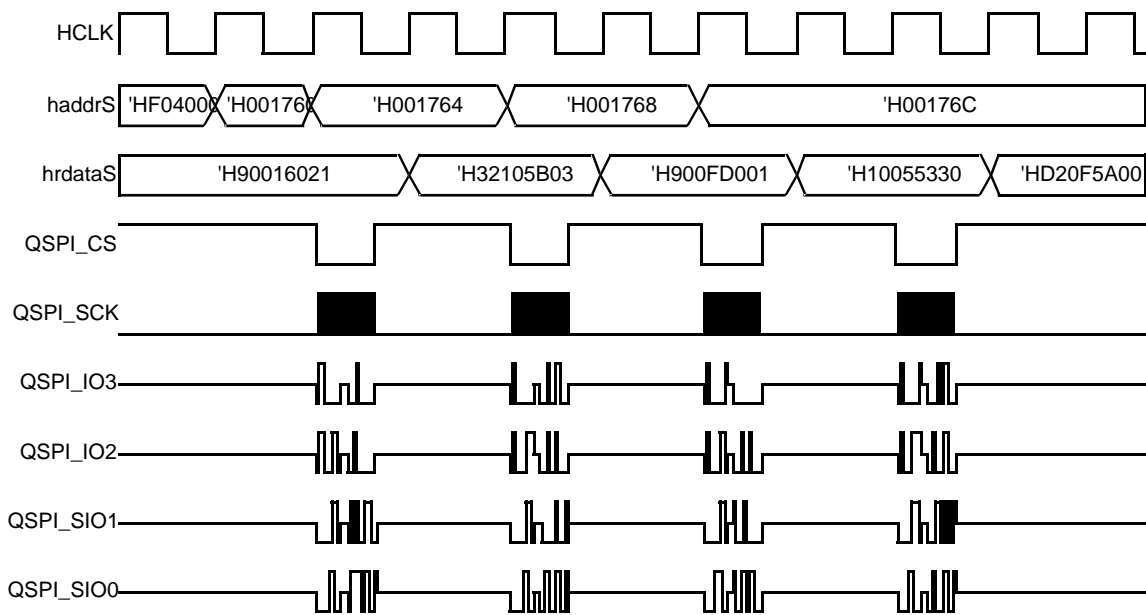

Figure 46. QSPI Split burst timing for low power (QSPI_FORENSEQ_EN=1)

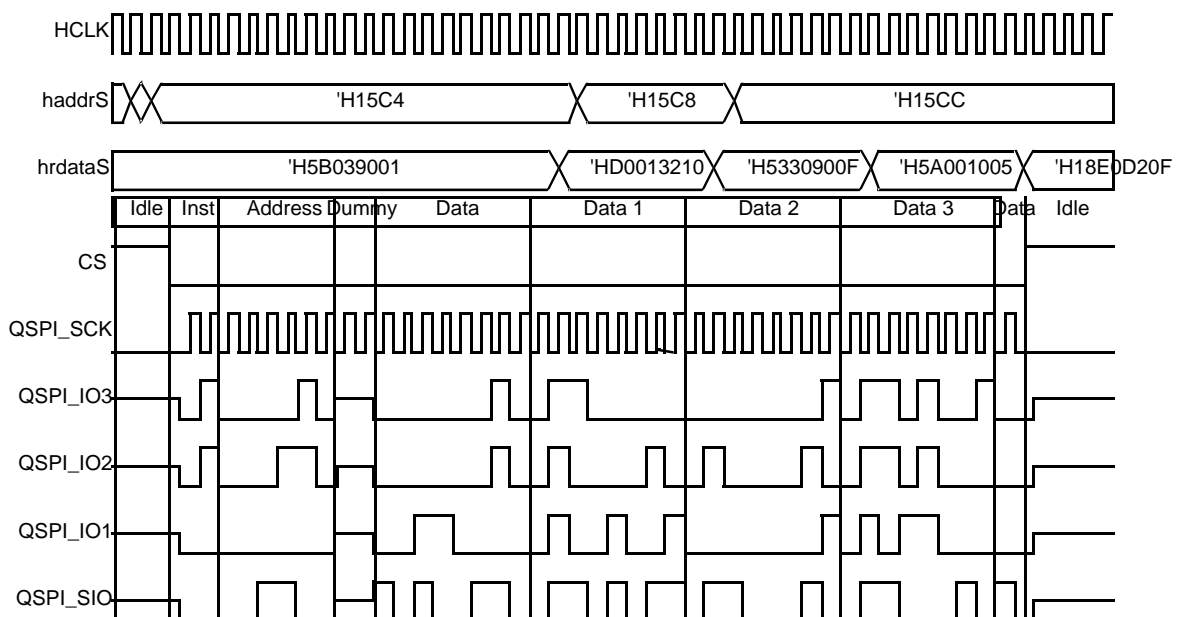

Figure 47. QSPI Burst timing for high performance (QSPI_FORENSEQ_EN=0)

If QSPI_FORCENSE_EN=0, the QSPIC2 reads data in a burst address1/extra/dummy/data1, data2, dataN, keeping the QSPI_CS low during the complete burst. If set to "1", the burst is split into non-sequential accesses address1/extra/dummy/data1, address2/extra/dummy/data2, etc. making the QSPI_CS high between the accesses.

20.3 Programming

20.3.1 Auto Mode

Chip Selection

In Auto mode QSPI executes from address 0. See Arm chapter remap function.

Certain PSRAM RAM (for example, APmemory APS3204J) connected to the QSPI interface have a minimum time t_{CEM} that the #CE may stay low. Software must make sure that the QSPI CLK is not going too slow during a burst, otherwise RAM data might get lost.

Read Burst in Auto Mode

In the case of a read from the external device, in Auto mode, the QSPI controller generates a sequence of control signals. This is analyzed in the following phases: instruction phase, address phase, extra byte phase, dummy clocks phase and read data phase. These phases can be programmed through registers QSPIC2_BURSTCMDA_REG and QSPIC2_BURSTCMDDB_REG.

Bits QSPIC2_INST are used to set the selected instruction for the cases of incremental burst or single read access. If bit QSPIC2_WRAP_MD is equal to 1, bits QSPIC2_INST_WB can be used to set the used instruction for a wrapping burst read access. The length and size is described by the bits QSPIC2_WRAP_LEN and QSPIC2_WRAP_SIZE respectively. In all other cases, the QSPIC2_INST is the selected instruction.

If instruction is to be transmitted only during the first access after the selection of Auto mode, the QSPIC2_INST_MD must be equal to 1.

To enable the extra byte phase, set 1 to the QSPIC2_EXT_BYTE_EN register. The transmitted byte during the extra byte phase is specified from the QSPIC2_EXT_BYTE register. To disable (hi-z) the output pads during the transmission of bits [3:0] of extra byte, write 1 to the QSPIC2_EXT_HF_DS register.

The number of dummy bytes during the dummy clocks phase is specified at QSPIC2_DMY_NUM.

The SPI BUS mode during each phase can be configured as follows:

- QSPIC2_INST_TX_MD for the instruction phase
- QSPIC2_ADR_TX_MD for the address phase
- QSPIC2_EXT_TX_MD for the extra byte phase
- QSPIC2_DMY_TX_MD for the dummy byte phase
- QSPIC2_DAT_RX_MD for the read data phase.

If the Quad SPI mode is selected in any of the above phases, write 0 to the QSPIC2_IO3_OEN and QSPIC2_IO2_OEN.

If the serial flash Memory must be prepared for reading with the use of any instruction except the read instruction, then the Manual mode must be used for the programming of the above instructions.

The final step to enable the use of Auto mode of operation is to set QSPIC2_AUTO_MD equal to 1.

Write Bursts in Auto Mode

In the case where the connected memory is a serial PSRAM, the controller can serve requests for write accesses. This is implemented, as in the case of the read burst, when the Auto mode of operation is active (QSPIC2_AUTO_MD = 1). Additionally, the external device must be declared to the QSPI controller as a serial RAM (QSPIC2_SRAM_EN = 1).

Under these conditions the QSPI controller generates a sequence of control signals in SPI BUS, for each request for write burst access towards the external device. This sequence of control signals is analyzed in the following phases: instruction phase, address phase, extra byte phase, and write data phase. These phases can be programmed through the register QSPIC2_AWRITECMD_REG.

Bits QSPIC2_WR_INST are used to define the write instruction. This instruction is used for all the cases of bursts: single access, incremental burst or wrapping burst. The controller handles them accordingly to implement all the lengths of the bursts.

The SPI BUS mode during each phase can be set by the register bits:

- QSPIC2_WR_INST_TX_MD for the instruction phase
- QSPIC2_WR_ADR_TX_MD for the address phase
- QSPIC2_WR_DAT_TX_MD for the read data phase

If the serial RAM must be configured with a special command sequence prior to the write instruction, Manual mode must be used.

20.3.2 Manual Mode

For the Manual mode, QSPIC2_AUTO_MD must be equal to zero. Manual operation of the bus signal is done via QSPIC2_CTRLBUS_REG:

- Start /End of an access can be controlled using bits QSPIC2_EN_CS and QSPIC2_DIS_CS respectively
- SPI mode configured with bits QSPIC2_SET_SINGLE, QSPIC2_SET_DUAL and QSPIC2_SET_QUAD

Writing to QSPIC2_WRITEDATA register generates a data transfer from the QSPIC2 to the SPI bus. A read access at QSPIC2_READDATA register generates a data transfer from the SPI bus. Writing to QSPIC2_DUMMYDATA register generates a number of clock pulses to the SPI bus. During this activity in the SPI bus, the QSPI_IO data pads are in *hi-z* state.

When an access to the SPI bus through QSPIC2_WRITEDATA, QSPIC2_READDATA and QSPIC2_DUMMYDATA is very slow, the delay in access to the AHB is very high. In this case, set the QSPIC2_HRDY_MD register equal to 1. With this feature, the hready signal of the SB slave interface is always equal to 1, when accessing the WriteData, ReadData, and DummyData registers. All masters can access the AHB bus without waiting for transmission completion on SPI Bus. A read of the QSPIC2_BUSY register must be done to check the end of the activity at the SPI bus, before any more access is triggered. In this case, register QSPIC2_RECVDATA contains the received data at the end of a read access.

20.3.3 Clock Selection

The SPI clock mode is set with bit QSPIC2_CLK_MD. The supported modes for the generated SPI clock are:

- 0 = Mode 0. The QSPI_SCK is low when the bus is idle (QSPI_CS is high)
- 1 = Mode 3. The QSPI_SCK is high when the bus is idle (QSPI_CS is high)

The QSPI_CLK frequency has a programmable divider CLK_AMBA_REG[QSPIC2_DIV] which divides either XTAL or PLL by 1,2,4,8

20.3.4 Received Data

The standard method to sample the received data, is by using the positive edge of the QSPI_SCK. However, when the output delay of the serial flash is high, timing issues at the read path are very likely. For this reason, the QSPIC2 can be programmed to sample the received data with the negative edge of the QSPI_SCK. This is specified with the QSPIC2_RXD_NEG register.

Furthermore, the receive data can be pipelined by setting QSPI_RPIPE_EN=1 and the sample clock can be delayed using QSPI_PCLK_MD. Refer to the timing chapter for detailed QSPI Timing information.

20.3.5 Delay Line Configuration

When VDD = 0.9 V (POWER_CTRL_REG[VDD_LEVEL] = 0x0) and QSPI_CLK = 32 MHz, the QSPIC2_CTRLMODE_REG[QSPIC_PCLK_MD] bit field should be equal to 2. On the contrary, if VDD = 1.2 V then QSPIC2_CTRLMODE_REG[QSPIC_PCLK_MD] bit field should be equal to 7.

21. Step Motor Controller

Device:	DA14691	DA14695	DA14697	DA14699
Feature Availability:	x	x	x	✓

21.1 Introduction

The Motor Controller drives the motor that moves the hands in a watch. It is very flexible in defining commands for forward or backward hand movements. Up to four GPIOs can be used to drive a hand, and as much as five hands are supported. Up to 64 commands can be stored into a memory mapped RAM which serves as a command FIFO. The actual waveforms are pre-defined and stored in a 48-places register based memory.

Features

- A 30.5 μ s granularity for defining a slot used for waveform generation
- Supports up to five independent 4-signal pattern-generators for hands control
- Implements a 64 command FIFO and a separate memory for storing up to 12 different wave definitions (the number depends on the wave format)
- Keeps the commands read pointer in retained registers and triggers system CPU for storing the last movement to external NVM
- Can be triggered by CPU, a divided version of the sleep clock or an external programmable event from RTC
- Supports any kind of wave generation on signals-in-single, pair or quad mode
- Generates Interrupt to system CPU in case of a FIFO underrun or overflow
- Operates on pclk and uses the sleep clock for the pattern generation. The pattern generation clock should always be slower than pclk

Figure 48 shows a system overview of the Motor Controller.

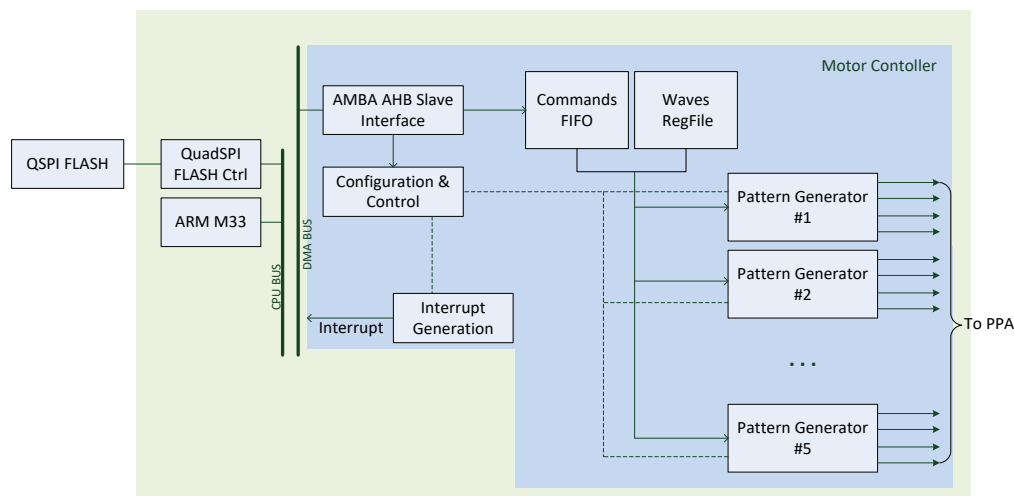

Figure 48. Motor Controller block diagram

21.2 Architecture

The architecture is comprised of a number of subblocks. These are:

- **Pattern Generator (PG):** Each PG is a hardware state machine, which generates a signal waveform on the output. This is based on specific parameters needed to drive the motor of a watch’s hand. Depending on the number of hands that need to be supported, the DA1469x can support up to five PGs. Each Pattern Generator will control four signals that can generate a waveform according to specific commands and waveform formats
- **Commands FIFO and Waves RegFile:** The Commands FIFO and the Waves RegFile are basically a hardware state machine that combines commands of a certain format, written in a Command buffer with wave definitions, which represents the waveform each PG must implement on the four different signals
- **Interrupt Generator:** This block is responsible for generating an interrupt
- **AMBA interface, Configuration and Control registers:** The registers that are supposed to control the flow and configure the engine according to the requirement parameters presented in the later section

21.2.1 Commands and Waves

Figure 49 explains the commands and waves format.

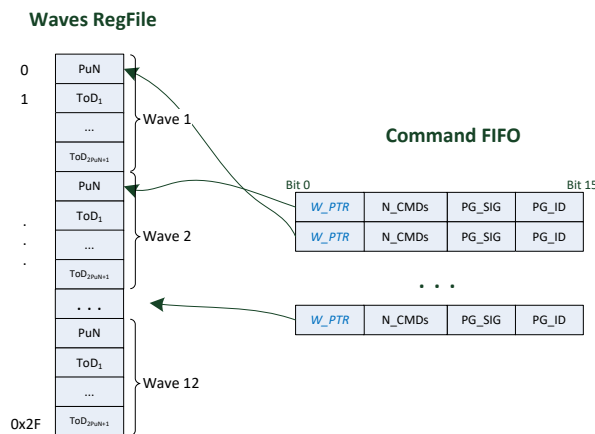

Figure 49. Commands and waveform format

The Commands FIFO is a memory mapped (for reading) RAM of 64x16bits. Writing this memory occurs in a FIFO mode (same address, Run through mode). Each Command FIFO word adheres to the format listed in Table 98.

Table 98: Commands format

Symbol	Bits	Description
W_PTR	5:0	This is a pointer to the waves memory space; supports up to 12 different waves.
N_CMDs	10:6	Defines the number of additional commands to be pushed to PGs on a single trigger.
PG_SIG	12:11	Pattern Generator signal; defines which signal (out of the four) is the command addressing.
PG_ID	15:13	Pattern Generator Identification; defines which PG the current command is for; supports up to 5 different PGs

Each command addresses a Pattern Generator (PG), one of the four signals within this PG indicates if more commands should be pushed along with it to this specific PG, and finally points to the wave format that needs to be decoded and implemented by the PG.

The Command FIFO can be exercised in two modes:

- **Run through mode:** The read pointer is continuously increased until the Command FIFO is empty.
- **Cyclic mode:** The read pointer reverts to the beginning of the FIFO after reaching a programmable value, the maximum value is 63.

The Wave format, followed by the contents of the Waves RegFile, is presented in Table 99.

Table 99: Waves format

Symbol	Bits	Description
PuN	4:0	Pulses Number: Defines the amount of active high pulses that the wave contains; up to 23 pulses are supported.
ToD _N	5 bits	Toggle Duration: Defines the amount of time before the wave toggles from high to low, or low to high. The value indicates the number of "slots". A "slot" is a programmable value, a multiple of the 30.5 μs clock period. The amount of ToD, N is defined by the following formula: $N = 2 * PuN + 1$. For example, if a PuN=2 is selected, 5 ToDs must be defined. Since the waves are always return-to-zero, the last ToD is not indicating toggling of the wave but just elapsed time from last toggle to the end of the wave.

The waveform granularity which defines "the slot", is a programmable value with a minimum of 30,5 μs per slot (based on the sleep clock period). The "slot" can be configured in form of five bits, therefore, maximum $32 * 30,5 \mu s = 976 \mu s$ (0 means $1 * 30.5 \mu s$).

The maximum waveform time is $(2 * 23 + 1) = 47$ ToDs. Each ToD can be 32 slots max., therefore, $47 * 32 * 488 \mu s / slot = 1468 \text{ ms}$.

Minimum waveform time will be $(2 * 1 + 1) = 3$ ToDs. Each ToD can be 1 slot min, hence $3 * 1 * 30 \mu s / slot = 90 \mu s$.

The commands pop from the FIFO on every trigger. A trigger can be one of three:

- A software writing to a register bit (auto-cleared)
- A clock tick (a divided version of the sleep clock. The division is maximum 64, resulting in a ~1 ms trigger period)
- An external signal coming from RTC, which can be programmed to be asserted on multiples of 10 ms

After a trigger, one or more commands are read out of the FIFOs, depending on the N_CMDs field. The reading of the commands happens on the fast clock (sys_clk), while the wave generation happens on the slow clock (mc_clk: lp_clk divided by MC_CLK_DIV).

The read pointer of the commands FIFO is a register which consists of retention flip-flops (i.e. the content will not be lost if the power domain, where the Motor Controller resides, is powered down). Moreover, this pointer will not be reset by hardware Reset, but by POReset only. Hence, in cases of Brown-Out Detection events (hardware reset) the value of the pointer will be retained.

Both read and write pointers are readable by the system CPU.

The waves should be loaded using the WAVETABLE_BASE register. The writing of the register should be done in 5-bit chunks, according to the four corresponding bit fields of the WAVETABLE_BASE register. Each 5-bit chunk is a PuN or ToD within the Waves RegFile. Figure 50 shows the way of arranging and loading the waves into the Waves memory space.

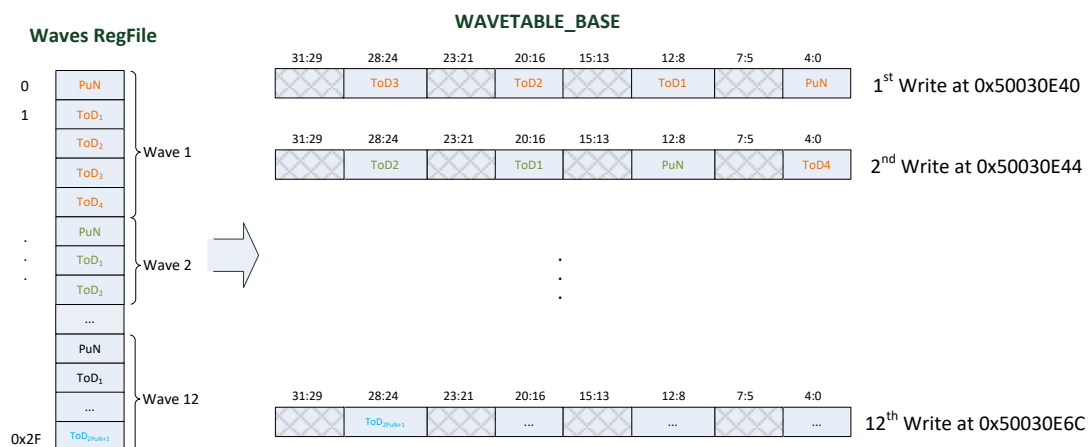

Figure 50. Loading waves into waves memory space

21.2.2 Pattern Generators (PGs)

All PGs monitor the output of the Commands FIFO and Wave memory. They all decode the PG_ID and if not addressed, they stop parsing, ignoring the rest of the message.

The PG addressed, stores the Waves table index of the start of the waveform. According to its programming, it should start implementing the waveform. It might also wait until one or more signal is instructed with commands, before it starts. The example in Figure 49 shows that two signals (SIG0 and SIG1) need a command before they start generating the waveform.

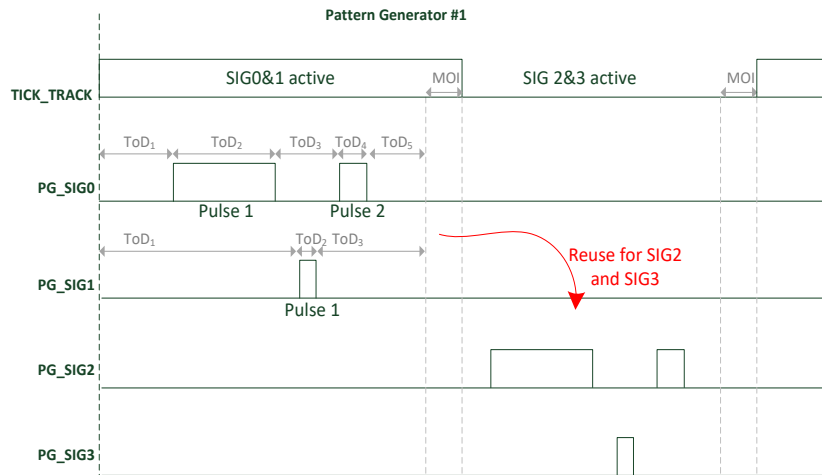

Figure 51. Waveform generation in signal pairs

In the previous example, the waveform parameters for PG_SIG0 are: PuN = 2, and the number of ToDs = 5. Another parameter that is configurable, is Mol (stands for **M**otor **I**dle) and indicates a number of slots where nothing happens. This time is always added at the end of a command and will be common for all five PGs. This parameter is 10 bits wide and 0 is allowed.

The PG can be configured to operate in “mirroring mode”, that is:

- A single signal replicates the wave of another one after Mol has elapsed
- A pair of signals replicate the waves of the other pair after Mol has elapsed

In the previous example, the PG is configured to operate in mirroring mode and more specifically in pairs.

As soon as the PG starts generating the waveform, a busy signal indicates to the Commands & Wave controller that this specific PG is busy, so no more waves can be received. If the next command were to address the same PG, it is discarded until the busy signals are de-asserted. If the next command(s) address other PGs, they are broadcasted. The busy signal should be de-asserted as soon as the waveform generation is finished.

21.2.3 Interrupt Generator

An interrupt is generated when:

- A PG has just started the waveform implementation. The BUSY signal positive edge is used as a notification. This interrupt source is disabled in cases of hands animations
- Read pointer – Write pointer < Threshold, where threshold is a programmable value indicating the amount of commands still left in the Command FIFO

The idea is that the CPU is notified after a successful start of the waveform, meaning the hand movement, so that the last state of the read pointer can be stored into a non-volatile flash. In case of a power failure, the system should be able to move the hand back to its last position. The following cases can be observed:

Table 100: Hand Position and Restoration Error

Hand	Read pointer storage	Remarks
Started, not finished	Started, not finished	Hand is restored at the actual position OR one tick away in case the wave has proceed enough to move the hand
Started, finished	Started, not finished	Hand is restored one tick away from the real position

Hand	Read pointer storage	Remarks
Started, not finished	Started, finished	Hand is restored one tick away from the real position OR at the actual position in case the wave has proceed enough to move the hand
Started, finished	Started, finished	Hand is restored at the actual position

Storing the value of the Read Pointer into external flash, also requires some time, so does the restoration process. Hence, the above error of one tick is depending on the relation of the tick period and the write/read process from the flash.

21.3 Programming

There is a simple sequence of steps that needs to be followed to program the Motor Controller:

1. Select the clock source of the system by writing the CLK_CTRL_REG[SYS_CLK_SEL] bit field and the low power (sleep) clock source by writing the CLK_CTRL_REG[LP_CLK_SEL] bit field.
2. Set up the clock divider for the motor controller slot using CLK_PER_REG[MC_CLK_DIV] bit field.
3. Configure GPIOs used for the Pattern Generator signals by writing the appropriate Px_yy_MODE_REG[PID] = 43 (PG).
4. Set up triggers for automatic mode (SMOTOR_CTRL_REG[TRIG_RTC_EVENT_EN] or SMOTOR_CTRL_REG[MC_LP_CLK_TRIG_EN]).
5. Set up FIFO operation mode (normal or cyclic) using SMOTOR_CTRL_REG[CYCLIC_MODE] bit field.
6. Set up the FIFO level thresholds (SMOTOR_CTRL_REG[SMOTOR_THRESHOLD]).
7. Set up IRQs depending on the case: for example, SMOTOR_CTRL_REG[SMOTOR_THRESHOLD_IRQ_EN], SMOTOR_CTRL_REG[SMOTOR_GENSTART_IRQ_EN], SMOTOR_CTRL_REG[SMOTOR_GENEND_IRQ_EN], PGx_CTRL_REG[GENSTART_IRQ_EN], PGx_CTRL_REG[GENEND_IRQ_EN]
8. Set up FIFOs IRQs depending on the case: for example, SMOTOR_CTRL_REG[SMOTOR_FIFO_UNR_IRQ_EN], SMOTOR_CTRL_REG[SMOTOR_FIFO_OVF_IRQ_EN]
9. Set up pattern generator signals triggers PGx_CTRL_REG[PG_START_MODE].
10. Load Waves memory (WAVETABLE_BASE) with the available wave patterns.
11. Enable the Motor Controller block by setting the CLK_PER_REG[MC_CLK_EN] bit.
12. Enable Pattern Generator signals by setting the PGx_CTRL_REG[SIGx_EN] bit.
13. Push commands into the FIFO (SMOTOR_CMD_FIFO_REG).
14. Generate patterns manually by popping commands (SMOTOR_TRIGGER_REG) or automatically by the configured trigger sources (RTC or divided sleep clock).

22. LCD Controller

Device:	DA14691	DA14695	DA14697	DA14699
Feature Availability:	x	✓	✓	✓

22.1 Introduction

The DA1469x is equipped with a LCD Controller, capable of supporting Parallel and Serial (SPI3/4) interfaces.

A global register file controls the parameters of the controller. After applying timing parameters, a dedicated DMA engine fetches data. Depending on the target screen, output can be formatted to different types as described in the following sections.

The architecture of the LCD Controller is depicted in [Figure 52](#).

Features

- 1-layer support
- Dedicated DMA engine
- Parallel and Serial (SPI3/4) I/Fs support
- Programmable IRQ

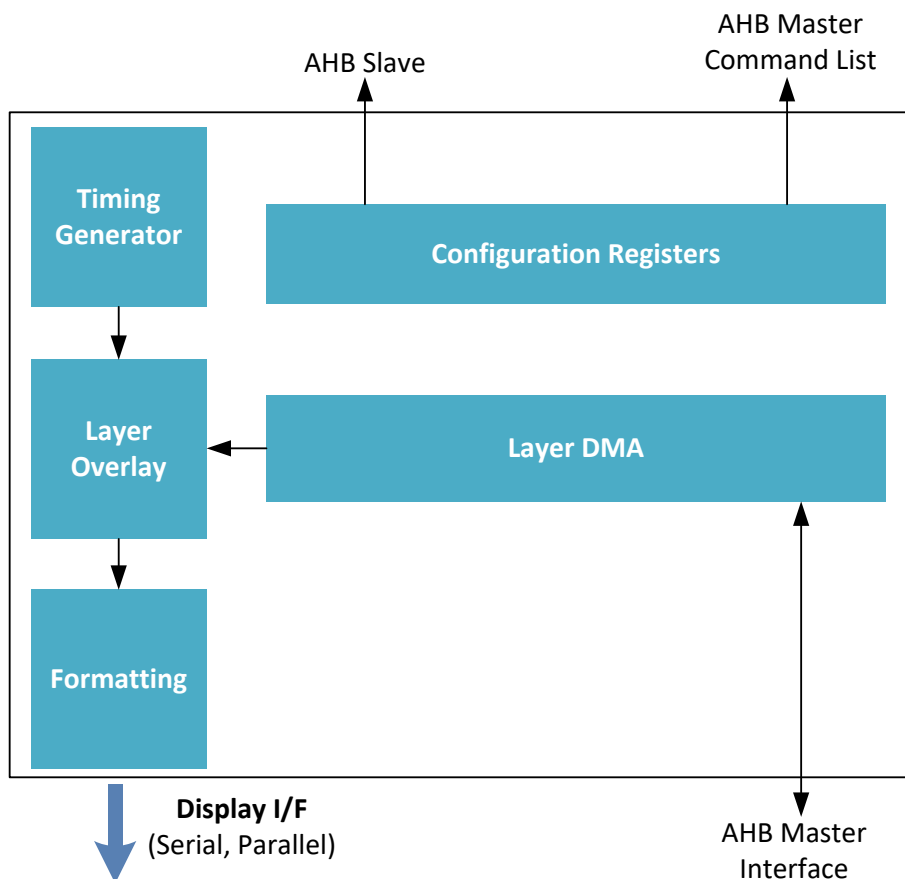

Figure 52. LCD controller block diagram

22.2 Architecture

22.2.1 Parallel LCD Interfaces

22.2.1.1 HSYNC/VSYNC Parallel Interface

The signal HSYNC is asserted on every scanline and the signal VSYNC is asserted on every frame. The polarity of the output *clock* signal can be defined as positive or negative, and the length of each pulse is programmable. [Figure 53](#) and [Figure 54](#). Show typical waveforms of operation.

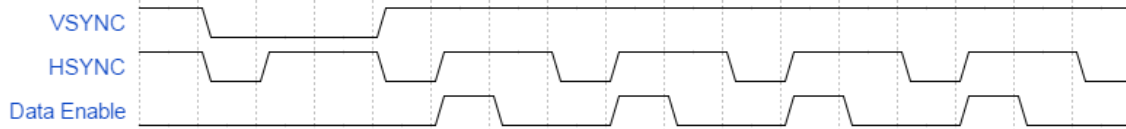

Figure 53: HSYNC/VSYNC Typical Waveform

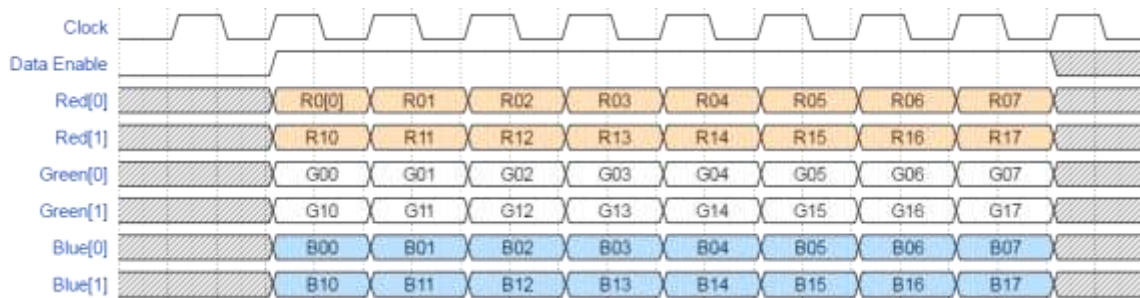

Figure 54. HSYNC/VSYNC color bits waveform

The available signals of the interface are shown in [Table 101](#).

Table 101: HSYNC/VSYNC parallel I/F pinout

Pin name	Type	Description	Source
CLK	Output	LCD Clock	LCD Controller
ENAB	Output	Indicate valid data on the LCD data bus	LCD Controller
HSYNC	Output	Reset the LCD column pointer to the edge of the display	LCD Controller
VSYNC	Output	Reset the LCD row pointer to top of the display	LCD Controller
RED0 (DATA[0])	Output	Red image data	LCD Controller
RED1 (DATA[1])	Output	Red image data	LCD Controller
GREEN0 (DATA[2])	Output	Green image data	LCD Controller
GREEN1 (DATA[3])	Output	Green image data	LCD Controller
BLUE0 (DATA[4])	Output	Blue image data	LCD Controller
BLUE1 (DATA[5])	Output	Blue image data	LCD Controller
Backlight	Output	LED driver signals	GPIO

22.2.1.2 JDI Parallel Interface

The available signals of the interface are shown in [Table 102](#).

Table 102: JDI parallel I/F pinout

Pin name	Type	Description	Source
HST	Output	Starts signal for the horizontal driver	LCD Controller
HCK	Output	Shifts clock for the horizontal driver	LCD Controller

Pin name	Type	Description	Source
ENB	Output	Writes enable signal for the pixel memory	LCD Controller
VST	Output	Starts signal for the vertical driver	LCD Controller
XRST	Output	Resets signal for the horizontal and vertical driver	LCD Controller
VCK	Output	Shifts clock for the vertical driver	LCD Controller
RED0	Output	Red image data	LCD Controller
RED1	Output	Red image data	LCD Controller
GREEN0	Output	Green image data	LCD Controller
GREEN1	Output	Green image data	LCD Controller
BLUE0	Output	Blue image data	LCD Controller
BLUE1	Output	Blue image data	LCD Controller
VCOM (Note 1)	Output	Common electrode driving signal (60Hz)	MCU GPIO
FRP (Note 1)	Output	Liquid crystal driving signal (60Hz)	MCU GPIO
XFRP	Output	Liquid crystal driving signal (60Hz inverted)	MCU GPIO
Backlight	Output	LED driver signals	MCU GPIO

22.2.2 Serial LCD Interfaces

22.2.2.1 SPI3/4 Serial Interface

The LCD controller supports the SPI serial interface with three or four distinct signals. The 3-lines serial interface use the CS (chip enable) signal, the SCLK (serial clock) signal and the DO (MOSI, serial data output) signal. The 4-line serial interface use an additional signal, the DCS (data/command select). The DO signal is regarded as a command when DCS is low and as data when DCS is high. The serial clock (SCLK) can be stopped when no communication is necessary.

During Write mode, the LCD controller sends the write commands and data to the LCD display. In the 4-line serial mode, the data packet (DO) contains only the transmission byte (8 bits). The control bit is transferred by the DCS signal. In the 3-lines serial mode, the data packet (DO) contains a control bit and a transmission byte (9 bits). In both cases, the MSB is transmitted first.

The CS signal is configurable. It can be set high or low to indicate the start of the data transmission. Data can be sampled either by the falling or the rising edge of the SCLK, depending on the configuration. The clock polarity is also configurable (clock starts at high or low edge).

If the CS signal remains active (high or low, depending on the configuration) after the last bit of the transmitted data packet, the LCD controller will transmit the MSB of the next byte at the next rising/falling edge of SCLK.

The available signals of the interface are shown in [Table 103](#).

Table 103: SPI3/4 serial I/F pinout

Pin name	Type	Description	Source
SCLK	Output	Serial clock signal	LCD Controller
MOSI	Output	Serial data	LCD Controller
CS	Output	Chip select	LCD Controller
DCS	Output	Data/Command select (when SPI4)	LCD Controller

Pin name	Type	Description	Source
EXTCOMIN (Note 1)	Output	COM Inversion Signal Input (1 Hz)	MCU GPIO
RST	Output	Reset display	MCU GPIO
DISP	Output	Display ON/OFF Control	MCU GPIO
Backlight	Output	LED driver signals	MCU GPIO

Note 1 CLK_SYS_REG[LCD_EXT_CLK_SEL]. Note that the clock output when CLK_SYS_REG[LCD_EXT_CLK_SEL] is set is available in sleep only if the PD_COM is kept active.

22.2.2.2 JDI SPI Serial Interface

The available signals of the interface are shown in [Table 104](#).

Table 104: JDI SPI serial I/F pinout

Pin name	Type	Description	Source
SCLK	Output	Serial clock signal	LCD Controller
MOSI	Output	Serial data	LCD Controller
CS	Output	Chip select	LCD Controller
DCS	Output	Data/Command select (when SPI4)	LCD Controller
TE	Input	Tearing effect. Use to synchronize MCU to frame memory writing	LCD Controller
EXTCOMIN (Note 1)	Output	COM Inversion Signal Input (1Hz)	MCU GPIO
RST	Output	Reset display	MCU GPIO
DISP	Output	Display ON/OFF Control	MCU GPIO
Backlight	Output	LED driver signals	MCU GPIO

Note 1 CLK_SYS_REG[LCD_EXT_CLK_SEL]. Note that the clock output when CLK_SYS_REG[LCD_EXT_CLK_SEL] is set is available in sleep only if the PD_COM is kept active.

22.2.4 Color Output Formats

22.2.4.1 SPI Output Formats

The supported SPI output data formats are depicted below.

Table 115: SPI3/4 – 8-bit RGB-332

Byte	Pixel	DCS	D7	D6	D5	D4	D3	D2	D1	D0
Byte1	n pixel	(Note 1)	R2	R1	R0	G2	G1	G0	B1	B0

Note 1 Available only in SPI3 mode.

Table 116: SPI3/4 – 8-bit RGB-444

Byte	Pixel	DCS	D7	D6	D5	D4	D3	D2	D1	D0
byte0	n pixel	(Note 1)	R3	R2	R1	R0	G3	G2	G1	G0
byte1	n/n+1 pixel	(Note 1>Note 1)	B3	B2	B1	B0	R3	R2	R1	R0
byte2	n+1 pixel	(Note 1)	G3	G2	G1	G0	B3	B2	B1	B0

Note 1 Available only in SPI3 mode.

Table 117: SPI3/4 – 8-bit RGB-565

Byte	Pixel	DCS	D7	D6	D5	D4	D3	D2	D1	D0
byte0	n pixel	(Note 1)	R4	R3	R2	R1	R0	G5	G4	G3
byte1	n pixel	(Note 1)	G2	G1	G0	B4	B3	B2	B1	B0

Note 1 Available only in SPI3 mode.

Table 118: SPI3/4 – 8-bit RGB-666

Byte	Pixel	DCS	D7	D6	D5	D4	D3	D2	D1	D0
byte0	n pixel	(Note 1)	R5	R4	R3	R2	R1	R0		
byte1	n pixel	(Note 1)	G5	G4	G3	G2	G1	G0		
byte2	n pixel	(Note 1)	B5	B4	B3	B2	B1	B0		

Note 1 Available only in SPI3 mode.

Table 119: SPI3/4 – 8-bit RGB-888

Byte	Pixel	DCS	D7	D6	D5	D4	D3	D2	D1	D0
byte0	n pixel	(Note 1)	R7	R6	R5	R4	R3	R2	R1	R0
byte1	n pixel	(Note 1)	G7	G6	G5	G4	G3	G2	G1	G0
byte2	n pixel	(Note 1)	B7	B6	B5	B4	B3	B2	B1	B0

Note 1 Available only in SPI3 mode.

22.2.4.2 JDI SPI Output Formats

The supported JDI SPI output data formats are depicted below.

Table 120: JDI SPI – 8-bit RGB-111-1 (3-bit mode)

Byte	Pixel	D7	D6	D5	D4	D3	D2	D1	D0
byte0	n pixel			R0	G0	B0	R1	G1	B1
byte1	n pixel			R2	G2	B2	R3	G3	B3
byte2	n pixel			R4	G4	B4	R5	G5	B5

Note 1 The Data order is as follows, MSB = D7, LSB = D0. Pixel Data is MSB = R0, LSB = B5 for Red, Green, Blue data.

Table 121: JDI SPI – 8-bit RGB-111-2 (4-bit mode)

Byte	Pixel	D7	D6	D5	D4	D3	D2	D1	D0
byte0	n pixel	R0	G0	B0		R1	G1	B1	
byte1	n pixel	R2	G2	B2		R3	G3	B3	
byte2	n pixel	R4	G4	B4		R5	G5	B5	

Note 1 The Data order is as follows, MSB = D7, LSB = D0. Pixel Data is MSB = R0, LSB = Dummy data for Red, Green, Blue, and dummy data.

Table 122: JDI SPI – 8-bit RGB-111-3 (3-bit mode)

Byte	Pixel	D7	D6	D5	D4	D3	D2	D1	D0
byte0	n pixel	R0	G0	B0	R1	G1	B1	R2	G2
byte1	n pixel	B2	R3	G3	B3	R4	G4	B4	R5
byte2	n pixel	G5	B5	R6	G6	B6	R7	G7	B7

Note 1 The Data order is as follows, MSB = D7, LSB = D0. Pixel Data is MSB = R0, LSB = B7 for Red, Green, Blue data.

Table 123: JDI SPI – 8-bit RGB-111-4 (1-bit mode)

Byte	Pixel	D7	D6	D5	D4	D3	D2	D1	D0
byte0	n pixel	d0	d1	d2	d3	d4	d5	d6	d7
byte1	n pixel	d8	d9	d10	d11	d12	d13	d14	d15

Note 1 The Data order is as follows, MSB = D7, LSB = D0. Pixel Data is MSB = d0, LSB = d15 for black and white data, where "0" indicates black and "1" indicates white.

22.3 Programming

See the SDK for the full featured LCD Software Library.

23. DMA Controller

Table 124: DMA controller

Device:	DA14691	DA14695	DA14697	DA14699
Feature Availability:	✓	✓	✓	✓

23.1 Introduction

The DMA controller has eight Direct Memory Access (DMA) channels for fast data transfers to and from SPI, UART, I2C, SRC, PCM, USB, GP_ADC and SD_ADC to and from any on-chip RAM. The DMA controller off-loads the Arm interrupt rate, if an interrupt is generated after a programmable number of transfers. A number of peripheral requests is multiplexed on the eight available channels, to increase utilization of the DMA. The block diagram of the DMA controller is depicted in [Figure 37](#).

Features

- Eight channels with optional peripheral trigger
- Full 32-bit source and destination pointers
- Flexible interrupt generation
- Programmable transfer length
- Flexible peripheral request per channel
- Option to initialize memory
- Programmable Edge-Sensitive request support
- Programmable support of AHB burst reads/writes, supporting both Memory-to-Memory and Memory-to-Peripheral transfers
 - Burst lengths supported are 8-beat (INCR8) and 4-beat (INCR4)
- Programmable bus error detection support and IRQ generation upon detection
- FREEZE support also in on-going Memory-to-Memory transfers
- Support of “secure transfer” mode by a dedicated, conditionally secure DMA channel (DMA7)

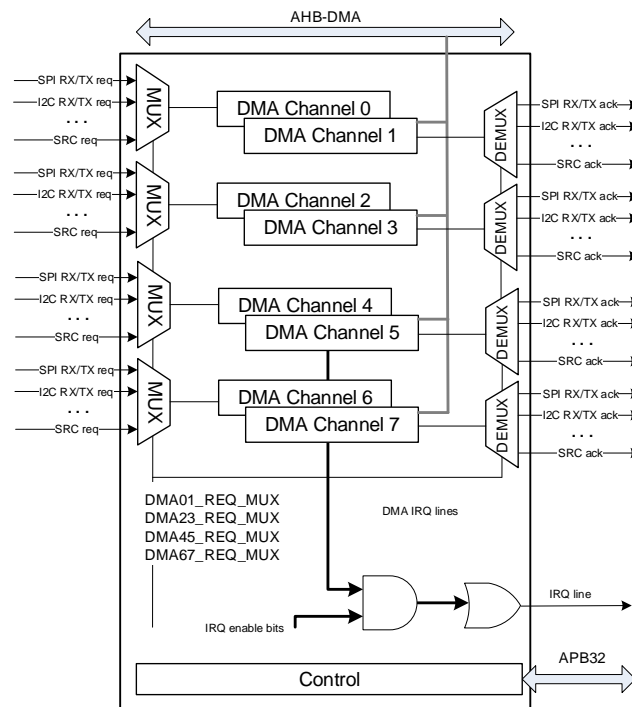

Figure 55. DMA controller block diagram

23.2 Architecture

23.2.1 DMA Peripherals

The list of peripherals that can request a DMA service, is in [Table 125](#).

Table 125: DMA served peripherals

Block	Direction(s)	Supported access rate
SPI	RX & TX	Single
SPI2	RX & TX	Single
QSPI RAM	Read & Write	Burst
QSPI FLASH	Read	Burst
UART	RX & TX	Single/Burst
UART2	RX & TX	Single/Burst
UART3	RX & TX	Single/Burst
I2C	RX & TX	Single/Burst
I2C2	RX & TX	Single/Burst
USB	RX & TX	Single
RAM	Read & Write	Burst
GP_ADC	Read	Single
SD_ADC	Read	Single
SRC	Left & Right	Single/Burst (Left or Right)
PCM	Left & Right	Single

The Edge-sensitive requests cannot be used when DMA services the USB Rx path (USB-to-Memory). The same applies in the case of the SPI_CTRL_REG[SPI_PRIORITY] = 1 (either Rx or Tx FIFO is enabled). Nevertheless, it is strongly recommended for the case of USB Tx path (Memory-to-USB) and when serving the UART and I2C peripherals (Memory-to-Peripheral).

23.2.2 Input/Output Multiplexer

The multiplexing of peripheral requests is controlled by DMA_REQ_MUX_REG. So, if DMA_REQ_MUX_REG[DMAxy_SEL] is set to a certain (non-reserved) value, the TX/RX request from the corresponding peripheral will be routed to DMA channels x (TX request) and y (RX request) respectively.

Similarly, an acknowledging de-multiplexing mechanism is applied.

However, when two or more bit-fields (peripheral selectors) of DMA_REQ_MUX_REG have the same value, the lesser significant selector will be given priority (see also the register's description).

23.2.3 DMA Channel Operation

A DMA channel is switched on with bit DMA_ON. This bit is automatically reset if the DMA transfer is finished. The DMA channels can either be triggered by software, or by a peripheral DMA request. If DREQ_MODE is 0, then a DMA channel is immediately triggered. If DREQ_MODE is 1 the DMA channel can be triggered by a Peripheral request.

If DMA starts, data is transferred from address DMAx_A_START_REG to address DMAx_B_START_REG for a length of DMAx_LEN_REG, which can be 8, 16, or 32 bits wide. The address increment is realized with an internal 16 bits counter DMAx_IDX_REG, which is set to 0 if the DMA transfer starts and is compared with the DMA_LEN_REG after each transfer. The register value is multiplied according to the AINC, BINC and BW values before it is added to DMA_B_START_REG and DMA_B_START_REG. AINC or BINC must be 0 for register access.

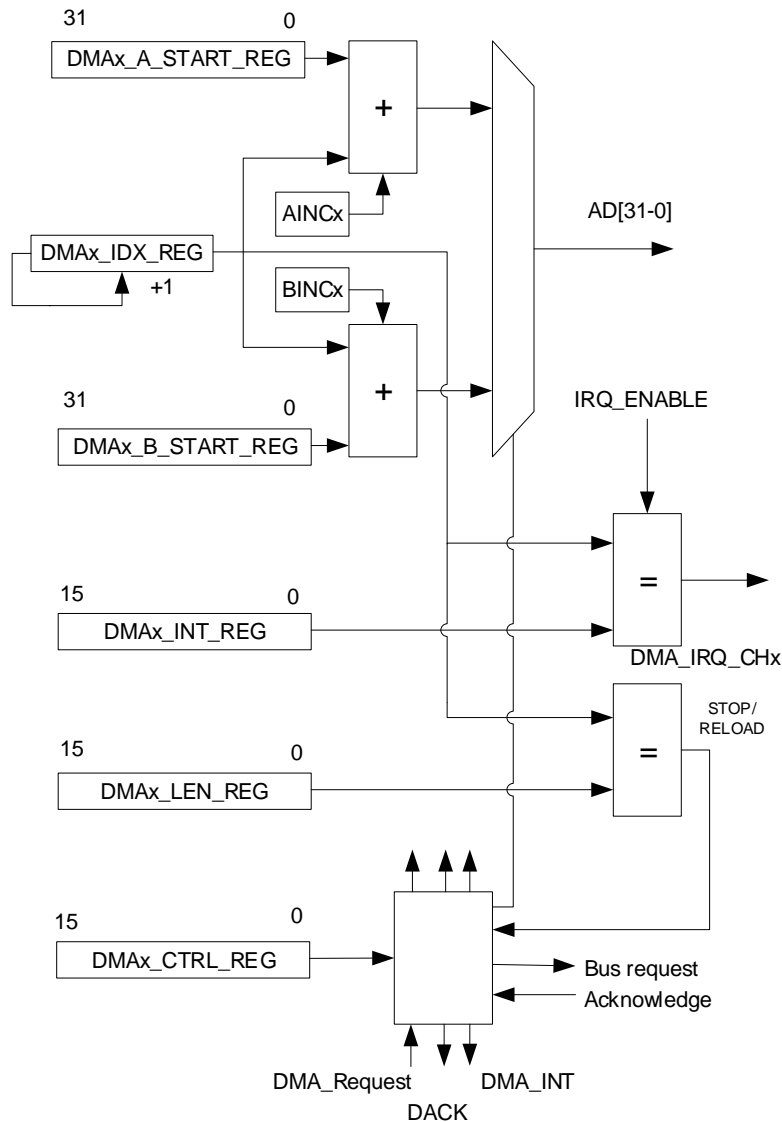

Figure 56. DMA channel diagram

If, at the end of a DMA cycle, the DMA start condition is still true, the DMA continues. The DMA stops when the transfer length is reached and, either DREQ_MODE is low, or DMAx_LEN_REG is equal to the internal index register. This condition also clears the DMA_ON bit.

If bit CIRCULAR is set to 1, the DMA controller automatically resets the internal index registers and continues from its starting address without intervention of the Cortex-M33. If the DMA controller is started with DREQ_MODE = 0, the DMA always stops, regardless of the state of CIRCULAR.

Each DMA channel can generate an interrupt if DMAx_INT_REG is equal to DMAx_IDX_REG. After the transfer and before DMAx_IDX_REG is incremented, the interrupt is generated.

Example: if DMA_x_INT_REG=0 and DMA_x_LEN_REG=0, there is one transfer and an interrupt.

There is no hardware protection from erroneous programming of the DMA registers. However, the software can be notified by an interrupt when a bus error has occurred in either the read or write cycle of the DMA transfer, if DMAx_CTRL_REG[BUS_ERROR_DETECT] is set.

23.2.4 DMA Arbitration

The priority level of a DMA channel can be set with bits DMA_PRI0[2:0]. These bits determine which DMA channel is activated in case more than one DMA channel requests DMA. If two or more channels have the same priority, an inherent priority applies, (see register description).

With DREQ_MODE = 0, a DMA channel can be interrupted by a channel with a higher priority if the DMA_IDLE bit is set.

When DMA_INIT is set, however, the DMA channel currently performing the transfer locks the bus and cannot be interrupted by any other channel, until the transfer is completed, regardless if DMA_IDLE is set. The purpose of DMA_INIT is to initialize a specific memory block with a certain value, fetched also from memory, without any interruption from other active DMA channels that may request the bus at the same time. Consequently, it should be used only for memory initialization, while when the DMA transfers data to/ from peripherals, it should be set to 0. Note that AINC must be set to 0 and BINC to 1, when DMA_INIT is enabled.

Memory initialization could also be performed without having the DMA_INIT enabled and by simply setting AINC to 0 and BINC to 1, provided that the source address memory value will not change during the transfer. However, it is not guaranteed that the DMA transfer will not be interrupted by other channels of higher priority when these request access to the bus at the same time.

23.2.5 Freeze DMA Channels

Each channel of the DMA controller can be temporarily disabled by writing a 1 to freeze all channels at SET_FREEZE_REG[FRZ_DMA].

To enable the channels again, a 1 to bits at the RESET_FREEZE_REG must be written.

The on-going Memory-to-Memory transfers (DREQ_MODE = 0) can also be interrupted (freeze).

23.2.6 Secure DMA Channel

If the security flag is enabled in the OTP header, then DMA channel #7 becomes a secure channel. This channel is then only used to move keys from the Symmetric Key Area to the AES block for encryption/decryption or the QSPI FLASH Controller for on-the-fly decryption without the CPU being able to intervene.

23.3 Programming

There is a simple sequence of steps that needs to be followed to configure the DMA Controller.

23.3.1 Memory to Memory Transfer

1. Set the length of data to be transferred (DMAx_LEN_REG).
2. Set the source address (DMAx_A_START_REG).
3. Set the destination address (DMAx_B_START_REG).
4. Configure the number of transfers until an interrupt is generated (DMAx_INT_REG).
5. Enable the IRQ of the used DMA channel if needed (DMA_INT_MASK_REG).
6. Configure transfer options:
 - a. DMAx_CTRL_REG[AINC]: Automatic increment of source address.
 - b. DMAx_CTRL_REG[BINC]: Automatic increment of destination address.
 - c. DMAx_CTRL_REG[BW]: Bus transfer width.
 - d. DMAx_CTRL_REG[BURST_MODE]: Enable DMA read/write bursts, if needed.
7. Start the DMA transfer by setting the DMAx_CTRL_REG[DMA_ON] bit.
8. Wait until transfer is finished (DMAx_CTRL_REG[DMA_ON] = 0) or the corresponding interrupt.
9. Clear the IRQ if it was enabled (DMA_INT_STATUS_REG).

23.3.2 Peripheral to Memory Transfer

1. Set the length of data to be transferred (DMAx_LEN_REG).
2. Set the source address (DMAx_A_START_REG) equal to the peripheral Rx register (for example, I2C_DATA_CMD_REG).
3. Set the destination address (DMAx_B_START_REG).
4. Configure the number of transfers until an interrupt is generated (DMAx_INT_REG).
5. Map the peripheral to the selected channels pair (DMA_REQ_MUX_REG[DMAxy_SEL]).
6. Configure transfer options:
 - a. DMAx_CTRL_REG[AINC]: Disable automatic increment of source address.

- b. DMAx_CTRL_REG[BINC]: Automatic increment of destination address.
 - c. DMAx_CTRL_REG[BW]: Bus transfer width.
 - d. DMAx_CTRL_REG[DREQ_MODE]: Enable triggering by peripheral DMA request.
 - e. DMAx_CTRL_REG[DMA_PRIO]: Set channel priority.
 - f. DMAx_CTRL_REG[BURST_MODE]: Enable DMA read/write bursts, if needed.
Note that SPI does not support burst transfers.
- 7. Enable the IRQ of the used DMA channel (DMA_INT_MASK_REG).
 - 8. Start the DMA transfer by setting the DMAx_CTRL_REG[DMA_ON] bit.
 - 9. Enable peripheral's DMA request (for example, I2C_DMA_CR_REG[TDMAE]).

24. Crypto Engine

Table 126: Crypto engine

Device:	DA14691	DA14695	DA14697	DA14699
Feature Availability:	✓	✓	✓	✓

24.1 Introduction

The Crypto engine aims to accelerate the algorithm calculations that are needed to implement the RFC4835. It implements AES in ECB, CBC and CTR modes. It also comprises HASH functions (SHA-1, SHA224/256/384/512, MD5). It supports AES128, AES 256 as well as HMAC-SHA-256 authentication protocol.

The AES/HASH engine uses a DMA engine for transferring encrypted/decrypted data to a shared memory in the AHB bus. The control registers of the IP are connected to the AHB bus.

The AES/HASH engine gives more flexibility to the way input data can be provided to the module. A calculation can be applied on fragmented input data, but not on data residing at a specific memory space, by means of successive register programming in the internal DMA engine.

Features

- AES (Advanced Encryption Standard) with 128, 192, or 256 bits key cryptographic algorithm
- HASH functions: MD5, SHA-1, SHA224/256/384/512 bits
- Modes of operation
 - ECB (Electronic Code Book)
 - CBC (Cipher Block Chaining)
 - CTR (Counter)
- AHB Master DMA machine for data manipulation
- AHB Slave register file for configuration

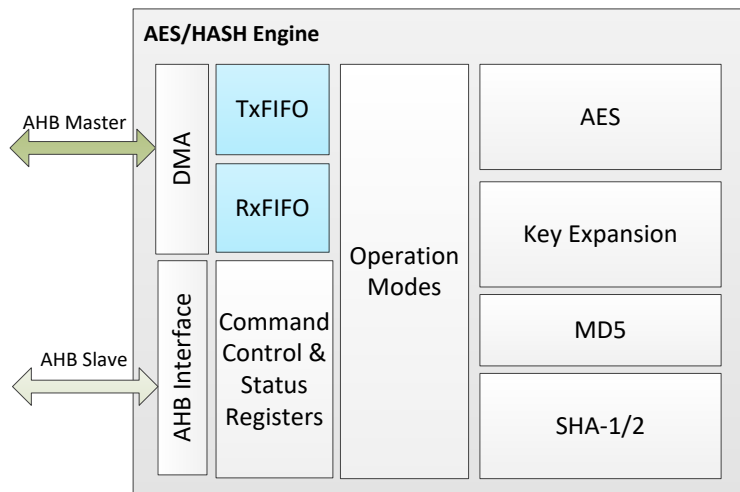

Figure 57. AES/HASH architecture

24.2 Architecture

The AES/HASH includes a DMA engine (AHB Master Interface) for transferring data between the IP and a shared memory. The control registers of the AES/HASH are connected to AHB interface (AHB Slave interface).

The Modes controls the AES by implementing the Respective mode that the selected encryption algorithms will operate each time. Also, Modes communicates with DMA through two FIFO's (RXFIFO and TXFIFO), which isolate the operation of the AES/HASH IP from the current status of the AHB-AMBA bus and also enable parallel transmission of data in bursts. By using burst transmission, the bus is utilized better because the bus access requests are reduced.

The "Ctrl FSM" block checks the FIFO's and DMA status continuously and decides for: the amount of data traffic, plus which of the FIFO's will be used. It also decides the "switching off" of the AES/HASH after transferring all results to the memory. The "HASH" block contains all the logic required for the realization of the hash algorithms calculations, as well as circuitry for the padding of data. It also contains glue logic for the transfer of the results to the Modes block.

24.2.1 AES

This part of the architecture implements the AES algorithm described in the AES-FIPS PUB 197. The capability it offers, is the encryption and decryption of 128 bits data blocks by using 128, 192, or 256 bits encryption key.

24.2.2 Operation Modes

The block "Modes" uses the AES to implement the following modes of operations:

- ECB (Electronic Code Book)
- CBC (Cipher Block Chaining)
- CTR (Counter)

Padding requirements of the algorithms, to convert all data to multiples of 16 bytes (for AES), must be addressed by software.

By applying successive programming of AES-CBC encryptions using software, the realization of the HMAC-XCBC-AES-96 algorithm is possible.

The implementation of the AES-CCM is feasible, just like the implementation of AES-CTR algorithms for encryption, and AES-CBC for authentication.

24.2.3 HASH

Padding at the input data is automatically applied as required by the hash algorithms. Two types of padding are implemented, due to the different algorithms supported. The purpose is to ensure that the message is a multiple of 512 or 1024 bits, depending on the algorithm. Padding is done in a similar way in both cases. After the last data byte, one extra byte of value 0x80 is added. Next, a number of bytes (0x00) is added, so that the overall size of the data block (including the extra bytes) mod 512/1024 is 448/896, depending on the algorithm. Following that, a 64/128-bits big-endian number is attached, which represents the size of the data block, in bits (without the padding). While in this process, TX/RX FIFOs are switched into 8-bytes mode.

The block packetizes the algorithm result (128 to 512 bits) into blocks of 64 bytes, so that they can be shifted to the TX FIFO. The following hash algorithms are implemented:

- MD5: RFC1321
- SHA-1: FIPS PUB 180-4
- SHA-224/256: FIPS PUB180-4. In this case only initialization changes
- SHA-384/512: FIPS PUB 180-4

24.3 Programming

24.3.1 AES Engine Programming

There is a simple sequence of steps that needs to be followed to program the AES Engine:

1. Enable the clock by setting the CLK_AMBA_REG[AES_CLK_ENABLE] bit.
2. Select the AES mode (CRYPTO_CTRL_REG[CRYPTO_HASH_SEL] = 0).
3. Define the mode of operation of the AES algorithm (CRYPTO_CTRL_REG[CRYPTO_ALG_MD]). For the CBC/CTR mode of operation the corresponding IV/CTR block should be defined in the CRYPTO_MREGx_REG registers.
4. Select the AES algorithm (CRYPTO_CTRL_REG[CRYPTO_ALG]).
5. Select the size of AES Key (CRYPTO_CTRL_REG[CRYPTO_AES_KEY_SZ]).
6. Use AES keys expansion if needed (CRYPTO_CTRL_REG[CRYPTO_AES_KEXP]). If the key expansion is enabled, define the (basic) key in the local CRYPTO_KEYS_START memory.
7. Set up data fetching address (CRYPTO_FETCH_ADDR_REG).

8. Set up data destination address (CRYPTO_DEST_ADDR_REG).
9. Set data length (CRYPTO_LEN_REG).
10. Select to Encrypt or Decrypt (CRYPTO_CTRL_REG[CRYPTO_ENCDEC]).
11. Enable the process by setting the CRYPTO_START_REG[CRYPTO_START] bit.
12. Wait the process to finish (CRYPTO_STATUS_REG[CRYPTO_INACTIVE] = 1).

24.3.2 HASH Engine Programming

There is a simple sequence of steps that needs to be followed to program the HASH Engine:

1. Enable the clock by setting the CLK_AMBA_REG[AES_CLK_ENABLE] bit.
2. Select the HASH mode (CRYPTO_CTRL_REG[CRYPTO_HASH_SEL] = 1).
3. Set the number of bytes which will be saved at the memory by the DMA (CRYPTO_CTRL_REG[CRYPTO_HASH_OUT_LEN], see register description).
4. Define the mode of operation of the HASH algorithm (CRYPTO_CTRL_REG[CRYPTO_ALG_MD], see register description).
5. Select the HASH algorithm (CRYPTO_CTRL_REG[CRYPTO_ALG], see register description).
6. Setup data fetching address (CRYPTO_FETCH_ADDR_REG).
7. Setup data destination address (CRYPTO_DEST_ADDR_REG).
8. Set data length (CRYPTO_LEN_REG).
9. Enable the process by setting the CRYPTO_START_REG[CRYPTO_START] bit.
10. Wait the process to finish (CRYPTO_STATUS_REG[CRYPTO_INACTIVE] = 1).

For both cases, an interrupt can be enabled upon the completion of the processing, by setting 1 to the CRYPTO_IRQ_EN (the interrupt should be enabled also in the CPU).

The clock of the Crypto Block should be disabled after the completion of each operation, by clearing the CLK_AMBA_REG[AES_CLK_ENABLE] bit, if there is no other operation to be performed.

25. True Random Number Generator

Table 127: True random number generator

Device:	DA14691	DA14695	DA14697	DA14699
Feature Availability:	✓	✓	✓	✓

25.1 Introduction

The TRNG is a non-deterministic Random Number generator used to provide the seed for encryption processes. Its output can be used as entropy input for a FIPS 140-2 approved deterministic random number generation process which is handled by software and hardware accelerators of the DA1469x.

The TRNG contains oscillator rings in digital logic. When combined, they create metastability on a Flip-Flop that eventually becomes the source of the entropy bits.

Features

- Optional NIST SP800-90A Hash_DRBG post processing, with SHA-256 function that uses the on-chip hardware accelerators
- Random numbers access through 32x32 bits FIFO on AHB bus
- Dedicated TRNG_IRQ Interrupt line
- Start-up time is 512 pclk cycles per 32 random bits
- Clock enable signals for optimal power saving

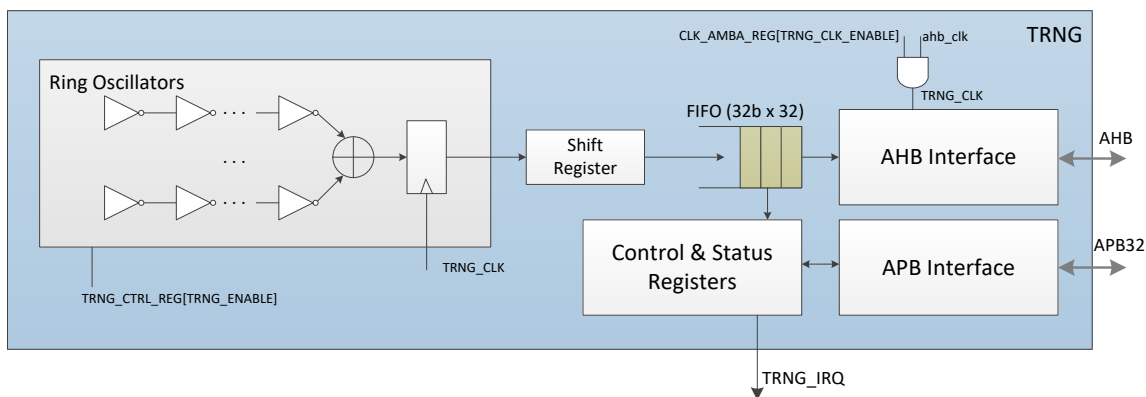

Figure 58. TRNG block diagram

25.2 Architecture

The TRNG is made up of a number of oscillator rings consisting of several inverters each. The output of the oscillator rings is accumulated in a shift register for whitening before it is stored in a 32x32 bits deep FIFO. The oscillator rings are enabled when the TRNG_CTRL_REG[TRNG_ENABLE] is set and the FIFO is not full.

The 32-bit random numbers are accessible via an AHB interface, while the registers are accessible through the APB32 interface.

25.3 Programming

There is a simple sequence of steps that needs to be followed to program the TRNG engine:

1. Set CLK_AMBA_REG[TRNG_CLK_EN] = 1 to enable the AHB bus access.
2. Set TRNG_CTRL_REG[TRNG_ENABLE] = 1 to start the random number generation. This signal is ignored when the FIFO is already full.
3. Poll TRNG_FIFOLVL_REG which provides the amount of data in the FIFO or wait for the TRNG_IRQ.
4. Read the random number from the TRNG FIFO at address 0x30050000 (TRNG_M)

5. To save power, set TRNG_CLK_EN=0 and set TRNG_ENABLE=0. The FIFO can only be accessed if TRNG_CLK_EN=1.

All signals are handled following the little-endian format. That means that the Least Significant Byte (LSB) is stored at the lowest address.

After TRNG_CTRL_REG[TRNG_ENABLE] is set, 512 pclk clock cycles are needed per FIFO entry to be filled. So, for 32 FIFO entries $512 \times 32 = 16\text{K}$ pclk clock cycles or 500 μs if the 32 MHz clock is used.

26. Wake-Up Controller

Table 128: Wake-up controller

Device:	DA14691	DA14695	DA14697	DA14699
Feature Availability:	✓	✓	✓	✓

26.1 Introduction

The Wake-Up Controller can be programmed to wake up the DA1469x from the Extended/Deep Sleep (clocked) mode as well as from Hibernation (clockless) mode. It consists of two parallel circuits that can be programmed regarding the GPIO edge monitored one with a debouncing counter usually used for buttons and another that indicates which GPIO has toggled.

The block diagram illustrating the Wake-Up function is depicted in [Figure 59](#).

Features

- Monitors any GPIO state change
- Implements debouncing time from 0 up to 63 ms
- Latches the status of the monitored lines
- Generates three interrupts to Arm Cortex-M33
- Generates a signal bus towards PDC indicating which GPIO has toggled
- Wakes up the system from Hibernation, Deep or Extended Sleep

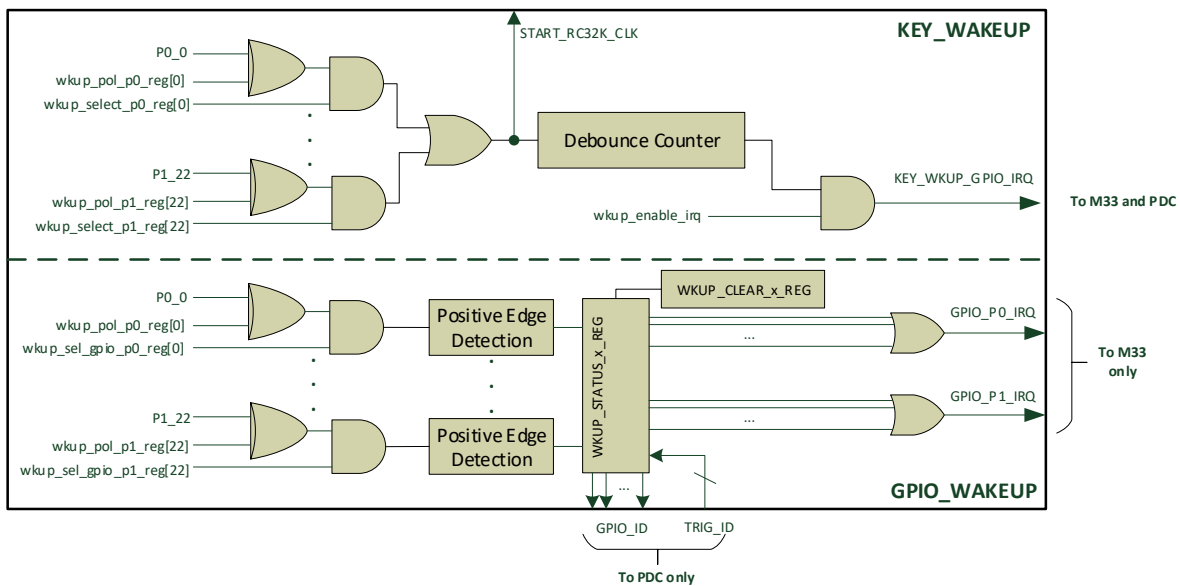

Figure 59: Wake-up controller block diagram

26.2 Architecture

The Wake-up controller can monitor all GPIO lines for an event. A line of XOR gates defines the polarity of the signal to be monitored. Two parallel structures are implemented explicitly separated in Figure 59 by a dashed line:

- **KEY_WAKEUP:** It can be programmed to monitor a number of GPIOs regarding their edge or level. After a GPIO toggles, a debounce counter can be triggered to debounce the key press before generating an interrupt. The KEY_WKUP_GPIO_IRQ will be generated towards the Cortex-M33 and the PDC (named as Debounced_IO in the PDC). The debouncing time can be programmed to be up to 63 ms. If debouncing is selected to be 0, the interrupt will be issued on an edge detection, but the external signal needs to be at least 2 x RC32K clock periods asserted considering the system being active. If the system is in Hibernation, the external signal needs to be at least 4 x RC32K periods asserted before it actually triggers the interrupt.

This circuit can wake up the system from Hibernation (clock-less sleep) as well as Deep or Extended (clocked) Sleep. Especially for Hibernation, this circuit must be programmed to wake the system up, as it is the only one that starts the RC32K oscillator as shown in the figure. Since the interrupt is kept asserted until acknowledged by SW, the Cortex-M33 will be able to receive it after its power domain has been powered up by PDC. Of course, a respective PDC entry needs to be in place for waking up Cortex-M33.

When the system is active, the circuit can keep on being used as a button press indicator with debouncing. Note that, if multiple GPIOs have been toggled there is no indication which one has generated the interrupt.

- **GPIO_WAKEUP:** It can be programmed to monitor edges (positive or negative) and latch them into a status register, so source is known by the application. This status register will be delivered to the PDC in form of a signal bus for being used as a trigger for the PDC entries. Moreover, an OR of each GPIO port signal will form a level interrupt towards the Cortex-M33, namely GPIO_P0_IRQ and GPIO_P1_IRQ, but the external GPIO pulse needs to be at least 2 x RC32K periods.

This circuit can wake up the system from any clocked sleep (Deep or Extended) but not from Hibernation. Since both interrupt lines are kept asserted until acknowledged by SW, the M33 will be able to receive them after its power domain has been powered up by PDC. Of course, a respective PDC entry needs to be in place for waking up Cortex-M33.

When the system is active, the circuit can keep on being used as an interrupt generator towards Cortex-M33 storing the GPIO state that has caused the interrupt in the first place.

26.3 Programming

There is a simple sequence of steps that needs to be followed to program the Wake-Up controller:

1. Enable the Wake-Up Controller by setting the CLK_TMR_REG[WAKEUPCT_ENABLE] bit.
2. Set up triggering polarity (WKUP_POL_Px_REG).
3. If debouncing is needed, define debounce time in WKUP_CTRL_REG[WKUP_DEB_VALUE].
4. Register PDC and/or KEY Interrupts:
 - a. Add PDC Entries (needed when the device goes to sleep)
 - b. Clear any latched values of the GPIOs (WKUP_CLEAR_Px_REG).
 - c. Add Wake-Up events (WKUP_SELECT_Px_REG)
 - d. Add GPIO interrupts (WKUP_SEL_GPIO_Px_REG)
5. If needed, add the corresponding ISRs and enable the interrupts (KEY_WKUP_GPIO_IRQn, GPIO_P0_IRQn, GPIO_P1_IRQn, PDC_IRQn).

27. General Purpose ADC

Device:	DA14691	DA14695	DA14697	DA14699
Feature Availability:	✓	✓	✓	✓

27.1 Introduction

The DA1469x is equipped with a high-speed ultra-low power 10-bit general purpose Analog-to-Digital Converter (GPADC). It can operate in Unipolar (Single-ended) mode and bipolar (differential) mode. The ADC has its own voltage regulator (LDO) of 1.2 V, which represents the full-scale reference voltage.

Features

- 10-bit dynamic ADC with 125 ns conversion time
- Maximum sampling rate 4 Msample/s
- Ultra-low power (13 μ A typical supply current at 100 ksample/s)
- Single-ended as well as differential input with two input ranges through 3x attenuator
- Eight single-ended in VFBGA100 (four in VFBGA86) or four differential external input channels (in both VFBGA100 and VFBGA86)
- Oversampling up to 128 steps providing effectively up to 11.2 bits accuracy (ENOB)
- Battery monitoring function
- Chopper function
- Offset and zero scale adjust
- Common-mode input level adjust
- DMA support

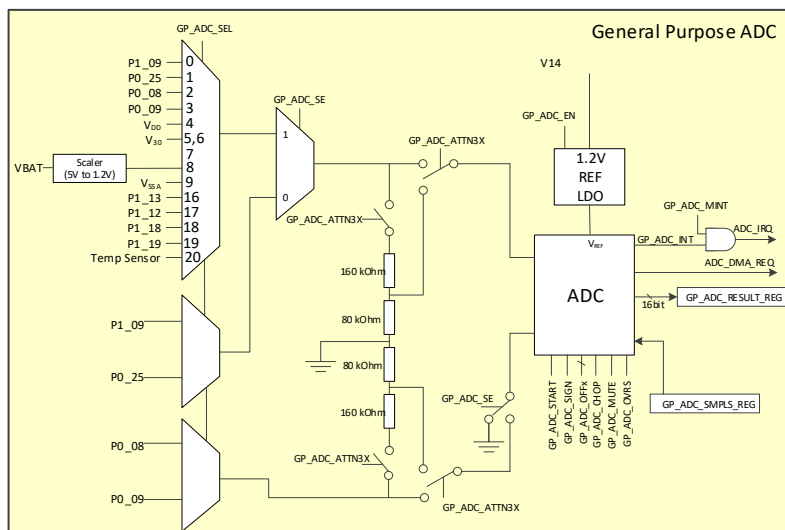

Figure 60: General-purpose ADC block diagram

27.2 Architecture

The ADC architecture shown in Figure 60 has the following sub-blocks:

- Analog to Digital converter (ADC)
 - ADC analog part internally clocked with 100 MHz (default) or the ADC_CLK selected with GP_ADC_CTRL_REG[GP_ADC_CLK_SEL]
 - ADC logic part clocked with the ADC_CLK (16 MHz or 96 MHz) selected with CLK_PER_REG[GPADC_CLK_SEL]
- 1.2 V Reference LDO for the ADC supply with a high PSRR enabled with GP_ADC_CTRL_REG[GP_ADC_EN]

- 1.2 V Digital LDO for the ADC digital logic supply enabled with GP_ADC_CTRL_REG[LDO_VDDD_HIGH_ENABLE]. Note that, this LDO supply comes from V18P which needs to be activated before the GPADC is used
- APB Bus interface clocked with the APB clock. Control and status registers are available through registers GP_ADC_*
- Maskable Interrupt (ADC_IRQ) and DMA request (ADC_DMA_REQ)
- ADC input channel selector. Up to eight specific GPIO ports, battery voltage (VBAT1) and the analog ground level (AVS) can be measured

27.2.1 Input Channels and Input Scale

Table 129 summarizes the single-ended or differential operation for the external channels via bit GP_ADC_CTRL_REG[GP_ADC_SE].

Input voltages up to 3.45 V can be handled if bit GP_ADC_CTRL2_REG[GP_ADC_ATTN3X] is set to 1. The VBAT scaler scales from 5 V to 1.2 V, so 1 LSB corresponds with $5 / 1023 = 4.88$ mV.

Table 129: GPADC input channels and voltage range

GP_ADC_ATTN3X	GP_ADC_SE	GP_ADC_SEL	Input channels	Input scale	Input limits
0	1	0, 1, 2, 3, 16, 17, 18, 19	P0_08, P0_09, P0_25, P1_09, P1_12, P1_13, P1_18, P1_19	0 V to +1.2 V	-0.1 V to +1.3 V
0	0	0	[P1_09, P0_25]	-1.2 V to +1.2 V	-1.3 V to +1.3 V
0	0	Not 0	[P0_08, P0_09]	-1.2 V to +1.2 V	-1.3 V to +1.3 V
1	1	0, 1, 2, 3, 16, 17, 18, 19	P0_08, P0_09, P0_25, P1_09, P1_12, P1_13, P1_18, P1_19	0 V to +3.6 V	-0.1 V to +3.45 V
1	0	0	[P1_09, P0_25]	-3.6 V to +3.6 V	-3.45 V to +3.45 V
1	0	Not 0	[P0_08, P0_09]	-3.6 V to +3.6 V	-3.45 V to +3.45 V

There are a few more channel inputs to GP ADC apart from the GPIOs listed below:

- VDD: this is the 0.9/1.2 V core supply rail of the ADC circuit
- V30: this is the V30 supply rail
- VSSA: this is the analog ground
- Tempensor: this is reading the output of the die temperature sensor

27.2.2 Operation

The ADC has the following modes of operation as shown in [Figure 60](#):

- Manual mode (See Section [27.2.3.1](#))
- Continuous mode (See Section [27.2.3.2](#))

In both modes the ADC performance can be increased by enabling conversion modes:

- Oversampling mode (See Section [27.2.4.2](#))
- Chopper mode (See Section [27.2.4.3](#))

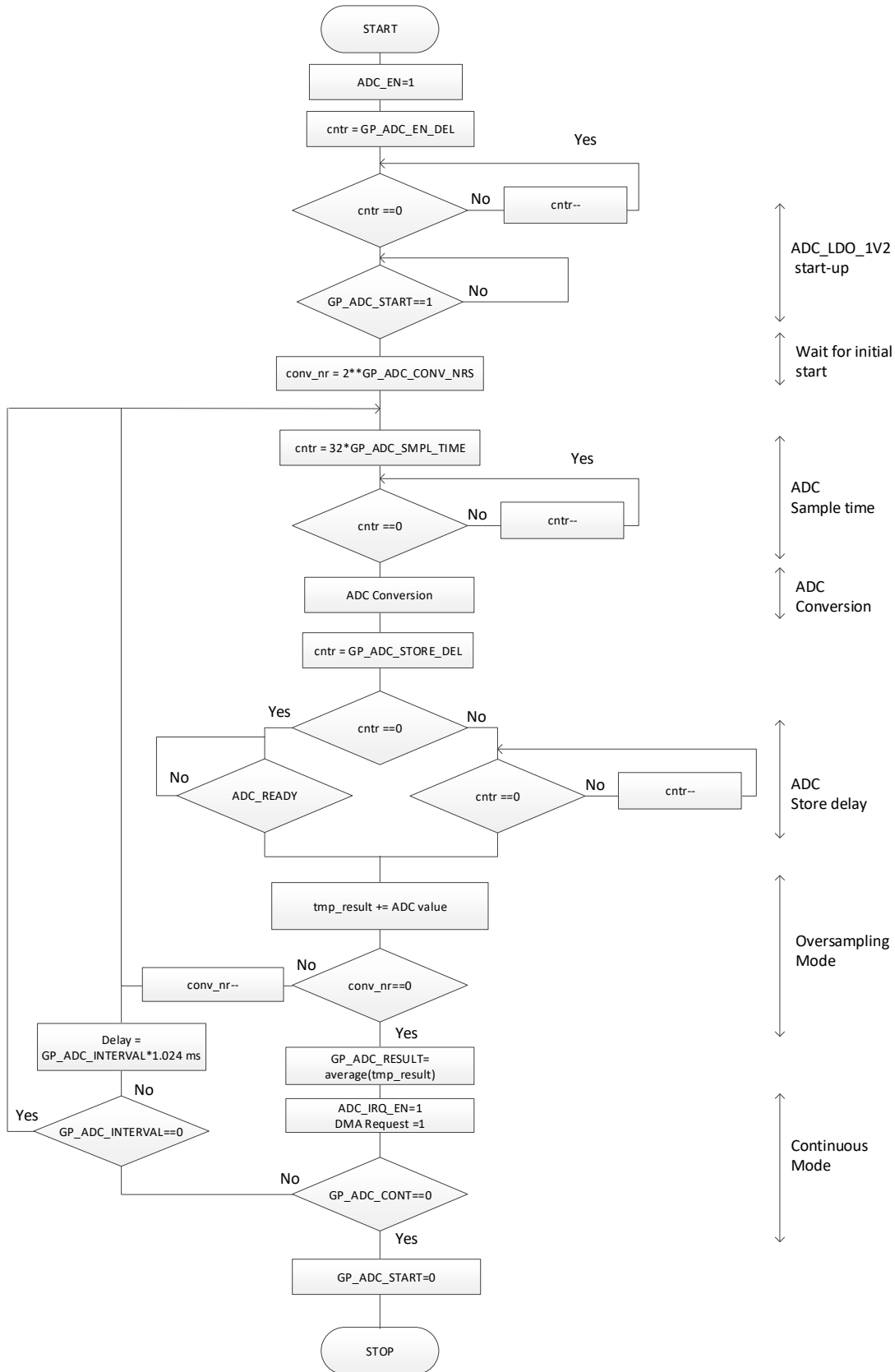

Figure 61. GPADC operation flow diagram

27.2.2.1 Enabling the ADC

The enabling or disabling of the ADC is triggered by configuring bit GP_ADC_CTRL_REG[GP_ADC_EN]. When the latter is set to 1, the LDO is first enabled, then after the delay value set in

GP_ADC_CTRL3_REG[GP_ADC_EN_DEL] (typically 20 μs to account for the LDO settling time) the ADC will be enabled, and an AD-conversion can be started. See Table 130 for recommended values.

Table 130: ADC_LDO_1V2 Start-Up delay

f _{ADC_CLK}	GP_ADC_EN_DEL	Delay (μs)
32 MHz	0x16	22
96 MHz	0x40	21.3

Formula:

$$GP_ADC_EN_DEL = 20E-6 * f_{ADC_CLK} / 32$$

This value must be rounded up.

The GPADC is a dynamic ADC and consumes no static power, except for the ADC_LDO_1V2 that consumes approximately 5 μA. Therefore, GP_ADC_EN must be set to 0 if the ADC is not used.

27.2.3 Operating Modes

27.2.3.1 Manual Mode

If GP_ADC_CTRL_REG[GP_ADC_START] is set to 1 the conversion is started. After a conversion, bit GP_ADC_START is set to 0, bit GP_ADC_INT is set to 1 (interrupt) and GP_ADC_RESULT_REG contains the valid ADC value. Software should always check that bit GP_ADC_START = 0 before starting a new conversion.

27.2.3.2 Continuous Mode

Setting GP_ADC_CTRL_REG[GP_ADC_CONT] to 1 enables the Continuous mode, which automatically starts a new ADC conversion after the current conversion is done. The GP_ADC_START bit is only needed once to trigger the first conversion. While Continuous mode is active, GP_ADC_RESULT_REG always contains the latest ADC value.

To correctly terminate Continuous mode, the GP_ADC_CONT bit must first be disabled. It must then wait until the GP_ADC_START bit is cleared to 0, so the ADC is in a defined state.

Note: Before making any changes to the ADC settings, Continuous mode must be disabled by setting bit GP_ADC_CONT to 0, while waiting until bit GP_ADC_START = 0.

At full speed, the ADC consumes approximately 75 μA. If the data rate is less than 100 ksample/s, the current consumption would be about 13 μA.

Programmable Delay

The time interval between two successive ADC conversions is programmable with GP_ADC_CTRL3_REG [GP_ADC_INTERVAL] in units of 1.024 ms. If GP_ADC_INTERVAL = 0, the conversion will restart immediately. If GP_ADC_INTERVAL is non-zero, it can take up to 1 ms before the first conversion is executed, because the ADC first synchronizes to the delay clock.

27.2.4 Conversion Modes

27.2.4.1 ADC Conversion

Each ADC conversion has three phases:

- Sampling
- Conversion
- Storage

The ADC conversion starts with the Sampling phase. This phase ends after the time set in GP_ADC_CTRL2_REG[GP_ADC_SMPL_TIME] and triggers the Conversion phase. When the conversion is ready, the ADC value is stored after a delay set in GP_ADC_CTRL2_REG[GP_ADC_STORE_DEL].

Sampling Phase

The sampling time constant τ_{ADC} depends on the output impedance of the source, the internal resistive dividers, and the internal sampling capacitor.

Table 131: ADC sampling time constant

ADC Input	τ_{ADC}
VBAT	500 ns
GPADC0, GPADC1 (GP_ADC_ATTN3X = 0)	$R_{OUT} * 0.5 \text{ pF}$
GPADC0, GPADC1 (GP_ADC_ATTN3X = 1)	$(R_{OUT} + 160 \text{ k}\Omega) * 0.5 \text{ pF}$

The settling time is approximately $7 * \tau_{ADC}$ for 10 bits accuracy and $9 * \tau_{ADC}$ for 12 bits accuracy. The settling time is clocked with $f_{ADC_CLK}/32$ and is counted with GP_ADC_CTRL2_REG[GP_ADC_SMPL_TIME].

Formula:

$$GP_ADC_SMPL_TIME = 7 * \tau_{ADC} * (f_{ADC_CLK} / 32)$$

This value must be rounded up.

For a settling time less than one ADC_CLK cycle, GP_ADC_SMPL_TIME can be set to 0.

Example: To measure VBAT with $\tau_{ADC} = 500 \text{ ns}$ and $f_{ADC_CLK} = 32 \text{ MHz}$:

$$GP_ADC_SMPL_TIME = 7 * 500E-9 * 32E6 / 32 = 3.5 \Rightarrow 4.$$

Conversion and Storage Phase

The ADC conversion time is around 125 ns, done with a fast, internal oscillator (100 MHz typ.). The conversion can be handshaked or a storage delay of a fixed number of cycles can be programmed.

Handshake mode (GP_ADC_STORE_DEL = 0)

In Handshake mode, the conversion result is available in GP_ADC_RESULT_REG after the conversion time (in ADC_CLK cycles) plus the synchronization time. Conversion and storage time (in ADC_CLK cycles):

$$f_{ADC_CLK} = 32 \text{ MHz: } 4 + 3$$

$$f_{ADC_CLK} = 96 \text{ MHz: } 12 + 3$$

Fixed mode (GP_ADC_STORE_DEL > 0)

In Fixed mode, the conversion result is available in GP_ADC_RESULT_REG after the programmed storage delay, whether or not the conversion is ready.

Conversion and storage time (in ADC_CLK cycles):

$$GP_ADC_STORE_DEL + 1$$

The total ADC conversion time is shown in [Table 132](#).

Table 132: Total ADC conversion time

GP_ADC_STORE_DEL	ADC Conversion Time (ADC_CLK Cycles)
0 (recommended)	$(4 \text{ or } 12) + 32 * GP_ADC_SMPL_TIME + 3$
> 0 (Note 1)	$32 * GP_ADC_SMPL_TIME + (GP_ADC_STORE_DEL + 1)$

Note 1 For $GP_ADC_SMPL_TIME = 0$ and $ADC_CLK = 96 \text{ MHz}$ the $GP_ADC_STORE_DEL$ value must at least be 11. See Section 27.2.10 to determine the value of $GP_ADC_SMPL_TIME$ based on the input impedance.

27.2.4.2 Oversampling Mode

In Oversampling mode, multiple successive conversions are executed, and the results are averaged to increase the Effective Number of Bits (ENOB). The number of conversions is programmable with $GP_ADC_CTRL2_REG[GP_ADC_CONV_NRS]$ and is given by $2^{GP_ADC_CONV_NRS}$.

The resulting $GP_ADC_RESULT_REG$ is 16 bits left-aligned and the effective number of significant bits increases with the number of conversions, as shown in Table 133.

Table 133: Oversampling mode effective number of bits

GP_ADC_CONV_NRS	Effective number of Bits (Left-Aligned) in GP_ADC_RESULT_REG
0	9.05
1	9.45
2	9.83
3	10.21
4	10.52
5	10.85
6	11.10
7	11.27

The preferred settings for acquiring the results of Table 133 are given in Table 134.

Table 134: Preferred settings for ENOB measurements

Description	Description register setting
Run digital at PLL speed	$PLL_SYS_CTRL1_REG[PLL_EN] = 1$
Use internal 100 MHz clock as SAR clock	$GP_ADC_CTRL_REG[GP_ADC_CLK_SEL] = 0$
Use auto zero and reference sampling in the LDO to suppress noise	$GP_ADC_CTRL_REG[GP_ADC_LDO_ZERO] = 1$
Disable chopping (default)	$GP_ADC_CTRL_REG[GP_ADC_CHOP] = 0$
Sign is not inverted (default)	$GP_ADC_CTRL_REG[GP_ADC_SIGN] = 0$
Measure single ended	$GP_ADC_CTRL_REG[GP_ADC_SE] = 1$
Single-Ended: (for example, P1_09)	$GP_ADC_CTRL_REG[GP_ADC_SEL] = 0$
Enable dynamic LDO current load	$GP_ADC_CTRL2_REG[GP_ADC_IDYN] = 1$
Enable static LDO 20A current load	$GP_ADC_CTRL2_REG[GP_ADC_I20U] = 1$
32 ADC clock cycles sampling time	$GP_ADC_CTRL2_REG[GP_ADC_SMPL_TIME] = 1$
Negative Offset centered (zero offset)	$GP_ADC_OFFN_REG = 0x200$
Positive Offset centered (zero offset)	$GP_ADC_OFFP_REG = 0x200$

27.2.4.3 Chopper Mode

By enabling Chopper mode, the internal ADC offset is cancelled by swapping the inputs and outputs between conversions. This method also smooths other non-ideal effects and is recommended for DC and slowly changing signals.

Chopper mode can be enabled in Manual, Continuous and Oversampling mode. When Oversampling mode is not active, two samples are taken with opposite signs. In the other cases, an even number of conversions is done, based on the value of GP_ADC_CTRL2_REG[GP_ADC_CONV_NRS].

Chopper mode is enabled by setting bit GP_ADC_CTRL2_REG[GP_ADC_CHOP] to 1. The mid-scale value of the ADC is the 'natural' zero point of the ADC (ADC result = 511.5 = 1FF or 200 Hex = 01.1111.1111 or 10.0000.0000 Bin). Ideally, this corresponds to $V_i = 1.2 \text{ V} / 2 = 0.6 \text{ V}$ in single-ended mode and $V_i = 0.0 \text{ V}$ in differential mode.

27.2.5 Additional Settings

If bit GP_ADC_CTRL2_REG[GP_ADC_ATTN3X] is set to 1, the input range is scaled by a factor of three, and the zero-point changes accordingly (1.8 V single-ended and to 0.0 V differential).

With bit GP_ADC_CTRL2_REG[GP_ADC_MUTE] = 1, the ADC input is switched to the mid-scale input level, so the ADC result ideally should be 511.5. If instead a value of 515 is observed, the output offset is +3.5.

With bit GP_ADC_CTRL2_REG[GP_ADC_SIGN] = 1 the sign of both the ADC input and output is inverted. Two sign changes have no effect on the signal path, but the sign of the ADC offset will change.

At the same output offset of +3.5 the ADC result with opposite GP_ADC_SIGN will be 508. The sum of these values equals $515 + 508 = 1023$. This is the mid-scale value of an 11-bit ADC, so one additional bit, due to the oversampling by a factor of two.

The LSB of this 11-bit word should be ignored when a 10-bit word is preferred. In that case the result is 511.5, so the actual output value will be either 511 or 512.

27.2.6 Non-Ideal Effects

Besides Differential Non-Linearity (DNL) and Integral Non-Linearity (INL), each ADC has a gain error (linear) and an offset error (linear). The gain error (E_G) of the GPADC slightly affects the effective input range. The offset error (E_{ofs}) causes the effective input scale to become non-centered. The offset error can be reduced by chopping or by offset calibration.

The ADC result also includes some noise. If the input signal itself is noise free (inductive effects included), the average noise level will be ± 1 LSB. Taking more samples and calculating the average value will reduce the noise and increase the resolution. This can be done by programming GP_ADC_CTRL2_REG[GP_ADC_CONV_NRS] to a non-zero value.

With a perfect input signal (for example, if a filter capacitor is placed close to the input pin) most of the noise comes from the low-power voltage regulator (LDO) of the ADC. Since DA1469x is targeted for ultra-compact applications, there is no pin available to add a capacitor at this voltage regulator output.

The dynamic current of the ADC causes extra noise at the regulator output. This noise can be reduced by setting bits GP_ADC_CTRL2_REG[GP_ADC_I20U] and GP_ADC_CTRL2_REG[GP_ADC_IDYN] to 1. Bit GP_ADC_I20U enables a constant 20 μA load current at the regulator output, so that the current will not drop to zero. Bit GP_ADC_IDYN enables a 10 μA load current during sampling phase, so that the load current during sampling and conversion phase becomes approximately the same.

27.2.7 Offset Calibration

A relative high offset E_{ofs} (up to 20 mV, so approximately 20 LSB) is caused by a very small dynamic comparator. This offset can be cancelled with the chopping function, but it still causes unwanted saturation effects at zero scale or full scale. With GP_ADC_OFFP_REG and GP_ADC_OFFN_REG the offset can be compensated in the ADC network itself. To calibrate the ADC follow the steps in [Table 135](#).

Table 135: GPADC calibration procedure for single-ended and differential modes

Step	Single-ended mode (GP_ADC_SE = 1)	Differential mode (GP_ADC_SE = 0)
1	Set GP_ADC_OFFP = GP_ADC_OFFN = 0x200; GP_ADC_MUTE = 0x1; GP_ADC_SIGN = 0x0	Set GP_ADC_OFFP = GP_ADC_OFFN = 0x200; GP_ADC_MUTE = 0x1; GP_ADC_SIGN = 0x0
2	Start conversion	Start conversion
3	adc_off_p = GP_ADC_RESULT - 0x200	adc_off_p = GP_ADC_RESULT - 0x200
4	Set GP_ADC_SIGN = 0x1	Set GP_ADC_SIGN = 0x1

Step	Single-ended mode (GP_ADC_SE = 1)	Differential mode (GP_ADC_SE = 0)
5	Start conversion	Start conversion
6	$adc_off_n = GP_ADC_RESULT - 0x200$	$adc_off_n = GP_ADC_RESULT - 0x200$
7	$GP_ADC_OFFP = 0x200 - 2 * adc_off_p$ $GP_ADC_OFFN = 0x200 - 2 * adc_off_n$	$GP_ADC_OFFP = 0x200 - adc_off_p$ $GP_ADC_OFFN = 0x200 - adc_off_n$

Note 1 The average of GP_ADC_OFFP and GP_ADC_OFFN should be 0x200 (with a margin of E_{ofs}).

To increase accuracy, it is recommended to set the GP_ADC_CTRL2_REG[GP_ADC_SMPL_TIME] = 2 or 3 and GP_ADC_CTRL2_REG[GP_ADC_CONV_NRS] = 3 or 4.

It is recommended to implement the above calibration routine during the initialization phase of DA1469x. To verify the calibration results, check whether the GP_ADC_RESULT value is close to 0x200 while bit GP_ADC_CTRL_REG[GP_ADC_MUTE] = 1.

27.2.8 Zero-Scale Adjustment

The GP_ADC_OFFP and GP_ADC_OFFN registers can also be used to set the zero-scale or full-scale input level at a certain target value. For instance, they can be used to calibrate GP_ADC_RESULT to 0x000 at an input voltage of exactly 0.0 V, or to calibrate the zero scale of a sensor.

27.2.9 Common Mode Adjustment

The common mode level of the differential signal must be 0.6 V (or 1.8 V with GP_ADC_ATTN3X = 1). If the common mode input level of 0.6 V cannot be achieved, the common mode level of the GPADC can be adjusted via GP_ADC_OFFP_REG and GP_ADC_OFFN_REG according to [Table 136](#). The GPADC can tolerate a common mode margin of up to 50 mV.

Table 136: Common mode adjustment

CM Voltage (V _{cm})	GP_ADC_OFFP = GP_ADC_OFFN
0.3 V	0x300
0.6 V	0x200
0.9 V	0x100

Any other common mode levels between 0.0 V and 1.2 V can be calculated from the table above. Offset calibration can be combined with common mode adjustment by replacing the 0x200 value in the offset calibration routine with the value required to get the appropriate common mode level.

Note: The input voltage limits for the ADC in differential mode are: -1.3 V to +1.3 V (for GP_ADC_ATTN3X = 0, see [Table 129](#)). The differential input range of the ADC is: -1.2 V < V[P0_09, P0_25] < +1.2 V. Therefore, if V_{cm} < 0.5 V or V_{cm} > 0.7 V, the input can no longer cover the whole ADC range.

27.2.10 Input Impedance, Inductance and Input Settling

The GPADC has no input buffer stage. During the sampling phase, a capacitor of 0.5 pF is switched to the input line. The precharge of this capacitor is at midscale level so the input impedance is infinite.

During the sampling phase, a certain settling time is required. A 10-bit accuracy requires at least seven time-constants τ_{ADC}, determined by the output impedance of the input signal source, the internal resistive dividers, and the 0.5 pF sampling capacitor. See [Table 131](#).

The inductance from the signal source to the ADC input pin must be very small. Otherwise filter capacitors are required from the input pins to ground (single-ended mode), or from pin to pin (differential mode).

To measure the noise level of the ADC and the LDO, bit GP_ADC_CTRL_REG[GP_ADC_MUTE] must be set to 1. The internal noise level should be less than ±2 LSB on average. When a higher noise level is observed on the input channel(s), applying external filter capacitor(s) will reduce the noise.

27.2.11 Reading Temperature Sensors

The General-Purpose ADC can read all temperature sensors integrated on the chip. The following temperature sensors are available:

1. The one used by the charger circuitry that provides a pretty good accuracy of the die temperature. To enable reading from it, in the GP_ADC_CTRL_REG, GP_ADC_DIFF_TEMP_EN] must be 0, GP_ADC_SEL must be 20, and GP_ADC_DIFF_TEMP_SEL must be 2. The formula that converts the ADC reading into temperature is as follows:
 - a. For uncalibrated measurements: $T = (\text{GPADC_value} - 734) / 2.3$ (10-bits resolution)
 - b. For measurements, using a single-point calibration: Store the GPADC-readout (GPADCTCAL) at a well-defined temperature "TCAL" (e.g. at room temperature)
 $T = \text{TCAL} + (\text{GPADC_value} - \text{GPADCTCAL}) / 2.3$
2. Three more simple diode-based sensors that are spread in the die and can be used for relative measurements only. They are placed next to the radio, the charger, and the bandgap respectively. To enable reading from each one, in the GP_ADC_CTRL_REG, GP_ADC_DIFF_TEMP_EN must be 1, GP_ADC_SEL must be 20 and GP_ADC_DIFF_TEMP_SEL defines which sensor will be read. The formula for converting the sensor reads into temperature difference, is as follows:
 $dT(t1 - t0) = (\text{GPADC_value}(t0) - \text{GPADC_value}(t1)) / 82$,
where t0 and t1 designate the successive reading time points.

Please note that, while measuring and/or calibrating, the system's power dissipation should be kept the same, otherwise the measurement is affected by the internal thermal gradient.

27.3 Programming

There is a simple sequence of steps that should be followed to program and use the General-Purpose AD Converter:

1. Enable the reference LDO by setting the GP_ADC_CTRL_REG[GP_ADC_EN] bit. This bit will also enable the digital part of the ADC.
2. Set up the GPIO input (Px_yy_MODE_REG[PID] = 26).
3. Select the input channel GP_ADC_CTRL_REG[GP_ADC_SEL].
4. Select the sampling mode (differential, single ended) by writing the GP_ADC_CTRL_REG[GP_ADC_SE] bit.
5. Select between manual and continuous mode of sampling (GP_ADC_CTRL_REG[GP_ADC_CONT]).
6. Set up extra options (see GP_ADC_CTRLx_REG description)
7. Start the conversion by setting GP_ADC_CTRL_REG[GP_ADC_START] bit.
8. Wait for GP_ADC_CTRL_REG[GP_ADC_START] to become 0 or interrupt being triggered (when used).
9. Clear the ADC interrupt by writing any value to GP_ADC_CLEAR_INT_REG.
10. Get the ADC result from the GP_ADC_RESULT_REG.

28. $\Sigma\Delta$ ADC

Device:	DA14691	DA14695	DA14697	DA14699
Feature Availability:	✓	✓	✓	✓

28.1 Introduction

The DA1469x is equipped with a second order 14 bits $\Sigma\Delta$ ADC. The conversion time for a 14-bit resolution is about 1 ms, allowing for a sampling rate equal to 1000 samples per second.

The reference voltage can be selected between the internal 1.2 V reference or an external voltage reference. It also supports VBAT measuring as well as eight external channels for sensing.

Features

- 14-bit resolution
- Maximum sampling rate of 1000 sample/s
- Single-ended as well as differential input with two input scales
- Eight single-ended in VBG100 (four in VBG86) or four differential external input channels in VFBGA100 (two in VFBGA86)
- Battery monitoring function
- DMA support with the GP DMA.

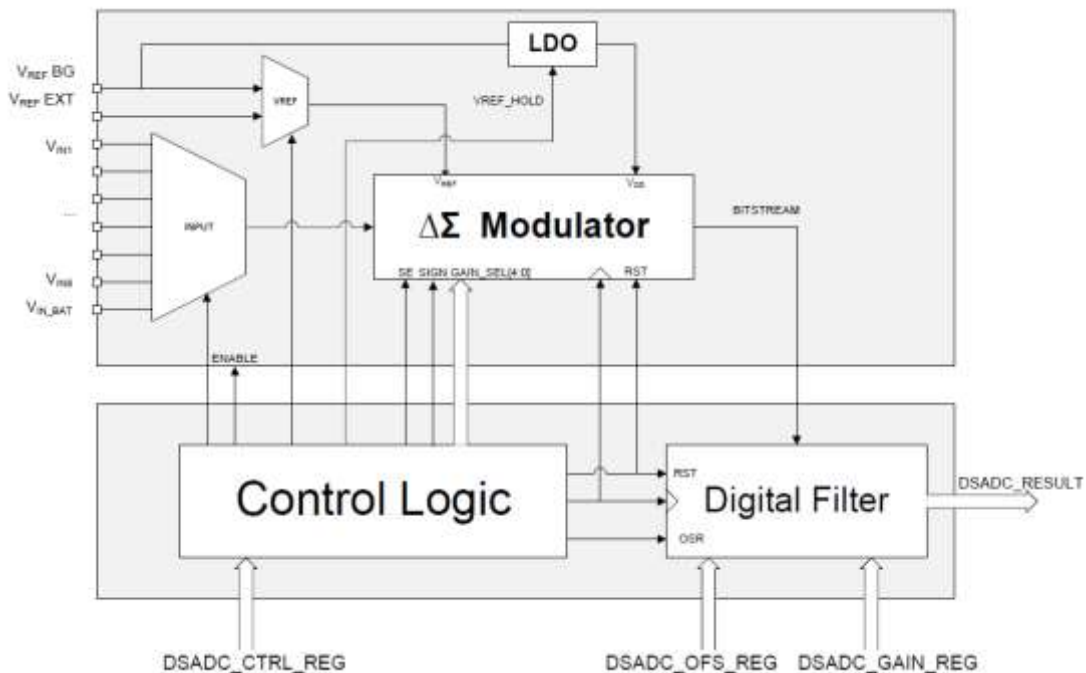

Figure 62. Block diagram of the $\Delta\Sigma$ ADC

28.2 Architecture

The block comprises an analogue part including the $\Delta\Sigma$ -Modulator and auxiliary circuitry, and a digital part containing the digital filter and control logic.

An 8-input multiplexer and a separate VBAT input is placed in front of the modulator. A reference selector is also added that allows an external reference voltage to be used. The internal reference voltage of 1.2 V is selected by default.

The analogue block is a modulator allowing 14 bits accuracy to be achieved (thermal noise floor). For single shot measurements, a higher oversampling rate (OSR) is required than for normal Sigma-Delta operation due to step-response behavior.

The digital block includes the digital filter and control logic for analogue. It takes care of the chopper and dynamic element matching algorithm. It also provides the clock and reset to the ADC and control signals to the input mux and reference-selection mux.

An internal divider of 160 k Ω and 3*160 k Ω is utilized for reading the battery voltage.

An external reference voltage can be applied at pins SDADC_REF (P0_16) and SDADC_GND (P0_06) of no more than 1.2 V to improve precision.

28.3 Programming

There is a simple sequence of steps that needs to be followed to program and use the $\Sigma\Delta$ AD Converter:

1. Enable the SDADC block by setting the SDADC_CTRL_REG[SDADC_EN] bit.
2. Set up the GPIO input (Px_yy_MODE_REG[PID] = 26).
3. Select the input channel for the positive side (SDADC_CTRL_REG[SDADC_INP_SEL]) and the negative side (SDADC_CTRL_REG[SDADC_INN_SEL], negative side is ignored in single ended mode).
4. Select the Voltage reference (SDADC_CTRL_REG[SDADC_VREF_SEL]).
5. Select the sampling mode (differential, single ended) by writing the SDADC_CTRL_REG[GP_ADC_SE] bit.
6. Select between manual and continuous mode of sampling (SDADC_CTRL_REG[SDADC_CONT]).
7. Set up extra options (see SDADC_CTRL_REG description)
8. Start the conversion by setting SDADC_CTRL_REG[SDADC_START] bit.
9. Wait for SDADC_CTRL_REG[SDADC_START] to become 0 or interrupt being triggered (when used).
10. Clear the ADC interrupt by writing any value to SDADC_CLEAR_INT_REG.
11. Get the ADC result from the SDADC_RESULT_REG.

29. Audio Unit (AU)

Device	DA14691	DA14695	DA14697	DA14699
Feature Availability	✓	✓	✓	✓

29.1 Introduction

The Audio Unit is made up of two digital interfaces, namely: a PDM and PCM. Its also has a Sampling Rate Converter (SRC), which is used for adjusting the sampling rate of audio samples between the two interfaces and memory.

The PDM interface provides a serial connection for one stereo or two mono input devices (for example, MEMS microphones) or output devices. The interface has a single clock PDM_CLK and one input/output PDM_DI/PDM_DO that can carry two channels in a time divided manner.

The PCM controller implements up to 192 kHz synchronous interface to external audio devices, ISDN circuits, and serial data interfaces. It enables master and slave modes and supports I2S and TDM formats.

The AU has dedicated DMA channels for the PCM and PDM streams. The PCM data flow is further supported by an internal dedicated 8x32-bit FIFO that cannot be used in stereo mode.

Features

- Supported conversions:
 - SRC_IN (32 bits) to SRC_OUT (32 bits)
 - PDM_IN (1bit) to SRC_OUT (32 bits)
 - SRC_IN (32 bits) to PDM_OUT (1 bit)
- SRC_IN, SRC_OUT Sample rates 8 kHz to 192 kHz
- SNR > 100 dB
- Single Buffer I/O with DMA support
- Automatic mode to adjust sample rate to the applied frame sync (for example, PCM_FSC)
- Manual mode to generate interrupts at the programmed sample rate. Adjustment is done by SW based on buffer pointers
- PCM (Master/Slave) interface
 - PCM_FSC
 - Master/slave 4 kHz to 96 kHz
 - Strobe Length 1, 8, 16, 24, 32, 40, 48, and 64 bits
 - PCM_FSC before or on the first bit (In Master mode)
 - 2x32 channels
 - Programmable slot delay up-to 31*8 bits
 - Formats
 - PCM mode
 - I2S mode (Left/Right channel selection) with N*8 for Left and N*8 for Right
 - IOM2 mode (double clock per bit)
 - Programmable clock and frame sync inversion
- PDM interface
 - PDM_CLK frequency 62.5 kHz - 4 MHz
 - Down-sampling to 32 bits in SRC
 - PDM_CLK on/off to support Sleep mode
 - PDM_DATA
 - (input): 1 Channel in stereo format
 - (output): 2 Channels in mono format, 1 Channel in stereo format
 - Programmable Left/Right channel selection.

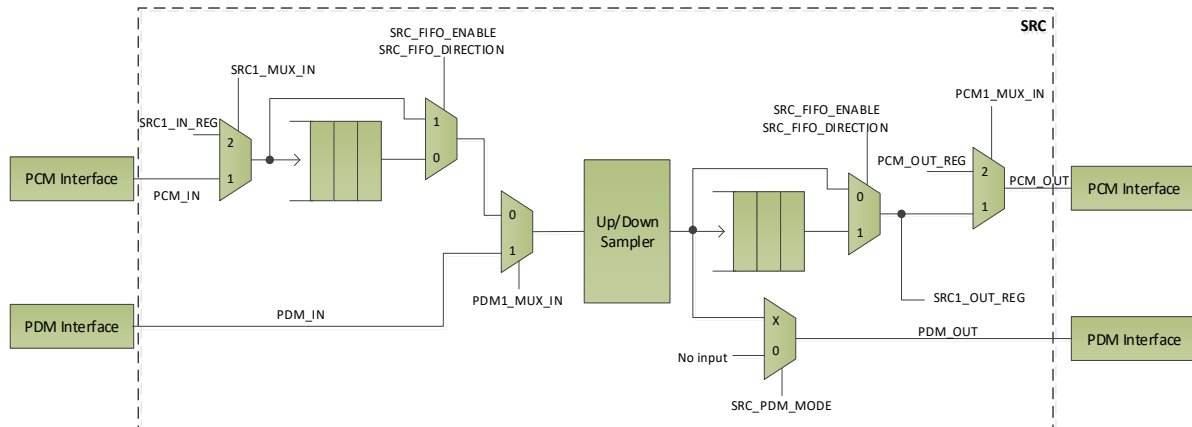

Figure 63. Audio unit block diagram

29.2 Architecture

29.2.1 Data Paths

The SRC block converts two 32-bit channels into, either a stereo pair, or two mono streams. PCM linear data pairs are transferred to SRC1_IN1/2; the output is 2x32-bit left-aligned on SRC1_OUT1/2. The two 1-bit PDM data inputs are received on PDM_IN and are converted to 2x32 bits, left-aligned to SRC_OUT.

The SRCx_IN input multiplexer (Figure 63) is controlled by APU_MUX_REG[PDM1_MUX_IN]. The input of these multiplexers comes from the audio interfaces or the SRC1_IN1/2_REG. The data to these registers is left-aligned, bits 31-8 are mapped on bits 23-0 of the SRC.

The 32 bits SRC outputs can be read in SRC1_OUT1_REG and SRC1_OUT2_REG and can also be routed to the PCM interface. The input selection of these multiplexers is also controlled by APU_MUX_REG[PCM1_MUX_IN].

An 8x32-bit FIFO can be connected to the SRC input or output data path when not in stereo mode. When the FIFO services the SRC input data path, an SRC input event triggers a FIFO write, while a CPU read access triggers a FIFO read. SRC_IN_IRQ is issued when the FIFO level increments to four samples. When the FIFO services the SRC output data path, an SRC output event triggers a FIFO read, while a CPU write access triggers a FIFO write. SRC_OUT_IRQ is issued when the FIFO level drops below five samples. FIFO operation can be completely disabled.

The SRC can be configured to operate in two different modes of operation:

- Manual mode
- Automatic mode.

In **manual mode**, the input/output sampling rate is determined by SRC1_IN_FS_REG / SRC1_OUT_FS_REG registers.

In **automatic mode**, the input/output sampling rate is automatically derived from the external synchronization signals and can only be read back at SRC1_IN_FS_REG / SRC1_OUT_FS_REG registers.

When PDM is used (input/output), SRC operates in automatic mode. The sampling rate reported in SRC1_IN_FS_REG register is PDM_CLK/64, 64 being the default oversampling ratio.

29.2.2 Up/Down Sampler

The Up/Down Sampler performs the required arbitrary resampling by polynomial interpolation at an 8x oversampled input rate and 16x oversampled output rate.

For maximum flexibility, a generic single cycle multiplier facilitates variable coefficient multiplications. The multiplier is combined with optional pre and post adders into an arithmetic unit.

29.2.3 PCM Interface

29.2.3.1 Channel Access and Delay

The PCM interface has two 32-bit registers for TX and RX, namely PCM1_IN1/OUT1_REG and PCM1_IN1/OUT2_REG for input and output directions respectively. These registers can be arranged as eight channels of 8 bits each, named channel 1 to channel 8. By a configurable clock inversion, channel delay and strobe length adjustment, various formats like PCM, I2S, TDM and IOM2 can be supported.

The 8 PCM channels can be delayed with a maximum delay of 31x8bits by configuring PCM1_CTRL_REG[PCM_CH_DEL]. Note that a high delay count in combination with a slow clock, can lead to the PCM_FSC sync occurring before all channels are shifted in or out. The received bits of the current channel may not be properly aligned in that case.

29.2.3.2 Clock Generation

The PCM clock (PCM_CLK) must be generated according to the required sample rate. There are two ways of generating the clock:

- **The Fractional Option.** Dividing the system clock by an integer and a fractional part (for example, inserting jitter in the clock pulse train). This is programmed in the PCM_DIV_REG and PCM_FDIV_REG respectively.
- **The Integer Only option.** Approximate the sample rate by adding more clock pulses than bits required. These extra pulses are ignored. This approach is used when external slave devices cannot tolerate the inserted jitter on the clock line. It is configured in PCM_DIV_REG.

The PCM_DIV_REG[PCM_DIV] is a 12 bits field which holds the integer part of the desired clock divider. The fractional part of the divider is stored in the 16 bits PCM_FDIV_REG register. The value of the register is calculated in the following way:

- The position of the left most 1 of the value in binary format defines the denominator
- The amount of 1s define the numerator of the fraction as explained in the example of [Table 137](#).

Table 137: PCM_FDIV_REG programming example

PCM_FDIV_REG (Hex)	PCM_FDIV_REG (Binary)	Numerator	Denominator	Fraction
0x0110	0b100010000	2	9	2/9
0x0101	0b100000001	2	9	2/9
0x1ABC	0b1101010111100	8	13	8/13
0xBEEF	0b1011111011101111	13	16	13/16
0xFEEE	0b1111111011101110	13	16	13/16

The FSC pulse is generated from the PCM_CLK by further dividing it by PCM_FSC_DIV.

Both clock generation options are explained in the following table, with 8 bits, 16 bits, 32 bits, and 48 bits in various sample rates.

Table 138: Fractional and Integer Only clock divisors for various PCM frequencies and sample rates

Sample rate (kHz)	Bits	Desired bit clock (kHz)	XTAL (kHz)					PLL (kHz)				
			32000					96000				
			Desired divider	Fractional option		Integer Only option		Desired divider	Fractional option		Integer Only option	
PCM_DIV_REG	PCM_FDI_V_REG	PCM_DIV_REG		Actual word size (Bits)	PCM_DIV_REG	PCM_FDIV_REG	PCM_DIV_REG		Actual word size (Bits)			
8	1*8	64	500	500		500	8	1500	1500		1500	8
8	1*16	128	250	250		250	16	750	750		750	16
8	1*24	192	166.667	166	2/3	160	25	500	500		500	24
8	1*32	256	125	125		125	32	375	375		375	32
8	2*8	128	250	250		250	8	750	750		750	8
8	2*16	256	125	125		125	16	375	375		375	16
8	2*24	384	83.333	83	1/3	80	25	250	250		250	24
8	2*32	512	62.5	62	1/2	50	40	187,5	187	1/2	150	40
16	1*8	128	250	250		250	8	750	750		750	8
16	1*16	256	125	125		125	16	375	375		375	16
16	1*24	384	83.333	83	1/3	80	25	250	250		250	24
16	1*32	512	62.5	62	1/2	50	40	187,5	187	1/2	150	40
16	2*8	256	125	125		125	8	375	375		375	8
16	2*16	512	62.5	62	1/2	50	20	187,5	187	1/2	150	20
16	2*24	768	41.667	41	2/3	40	25	125	125		125	24
16	2*32	1024	31.25	31	1/4	25	40	93,75	93	3/4	75	40
32	1*8	256	125	125		125	8	375	375		375	8
32	1*16	512	62.5	62	1/2	50	20	187,5	187	1/2	150	20
32	1*24	768	41.667	41	2/3	40	25	125	125		125	24
32	1*32	1024	31.25	31	1/4	20	50	93.75	93	3/4	75	40
32	2*8	512	62.5	62	1/2	50	10	187.5	187	1/2	150	10
32	2*16	1024	31.25	31	1/4	20	25	93.75	93	3/4	75	20

Multi-Core Bluetooth 5.2 SoC Family with System PMU

			XTAL (kHz)					PLL (kHz)				
			32000					96000				
32	2*2 4	1536	20.833	20	5/6	20	25	62.5	62	1/2	50	30
32	2*3 2	2048	15.625	15	5/8	10	50	46.875	46	7/8	25	60
48	1*8	384	83.333	83	1/3	N/A	N/A	250	250		250	8
48	1*1 6	768	41.667	41	2/3	N/A	N/A	125	125		125	16
48	1*2 4	1152	27.778	27	7/9	N/A	N/A	83.3333	83	1/3	80	25
48	1*3 2	1536	20.833	20	5/6	N/A	N/A	62.5	62	1/2	50	40
48	2*8	768	41.667	41	2/3	N/A	N/A	125	125		125	8
48	2*1 6	1536	20.833	20	5/6	N/A	N/A	62.5	62	1/2	50	20
48	2*2 4	2304	13.889	13	8/9	N/A	N/A	41.6666	41	2/3	40	25
48	2*3 2	3072	10.417	10	2/5	N/A	N/A	31.25	31	1/4	25	40

The yellow marked fields designate that the actual word size achieved in the Integer Only option, is larger than the required bits. The last clock pulses will be ignored in this case. For example, to get 24 bits at 8 kHz sampling rate, a clock of 192 kHz is required. In the Integer Only option, this is not possible. A higher clock will be generated (200 kHz), which results in a word of 25 bits. In this case, the last bit will be ignored.

29.2.3.3 External Synchronization

With the PCM interface in slave mode, the PCM interface supports direct routing through the sample rate converter (SRC). Any drift in PCM_FSC or other frame sync frequencies like 44.1 kHz, can be directly resampled to for example, 48 kHz internal sample rate.

29.2.3.4 Data Formats

29.2.3.4.1 PCM Master Mode

Master mode is selected if `PCM1_CTRL_REG[PCM_MASTER] = 1`.

In master mode, PCM_FSC is output and falls always over Channel 0. The duration of PCM_FSC is programmable with `PCM1_CTRL_REG[PCM_FSCLEN] = 1` or 8, 16, 24, 32 clock pulses high. The start position is programmable with `PCM1_CTRL_REG[PCM_FSCDEL]` and can be placed before or on the first bit of channel 0. The repetition frequency of PCM_FSC is programmable in `PCM1_CTRL_REG[PCM_FSC_DIV]` from 8 to 192 kHz.

If master mode selected, PCM_CLK is output and provides one or two clocks per data bit programmable in `PCM1_CTRL_REG[PCM_CLK_BIT]`. Note that, for `PCM_CLK_BIT=1`, the length of the FSC (`FSC_LEN`) is doubled.

The polarity of the signal can be inverted with bit `PCM1_CTRL_REG[PCM_CLKINV]`.

The PCM_CLK frequency selection is described in Section [29.2.3.2](#).

29.2.3.4.2 PCM Slave Mode

In slave mode, (bit `MASTER = 0`) PCM_FSC is input and determines the starting point of channel 0. The repetition rate of PCM_FSC must be equal to PCM_SYNC and must be high for at least one PCM_CLK cycle. Within one frame, PCM_FSC must be low for at least PCM_CLK cycle. Bit `PCM_FSCDEL` sets the start position of PCM_FSC before or on the first bit (MSB).

In Slave mode, PCM_CLK is input. The minimum received frequency is 256 kHz, the maximum is 12.288 MHz.

In Slave mode, the main counter can be stopped and resumed on a PCM1_FSC or PCM2_FSC rising edge.

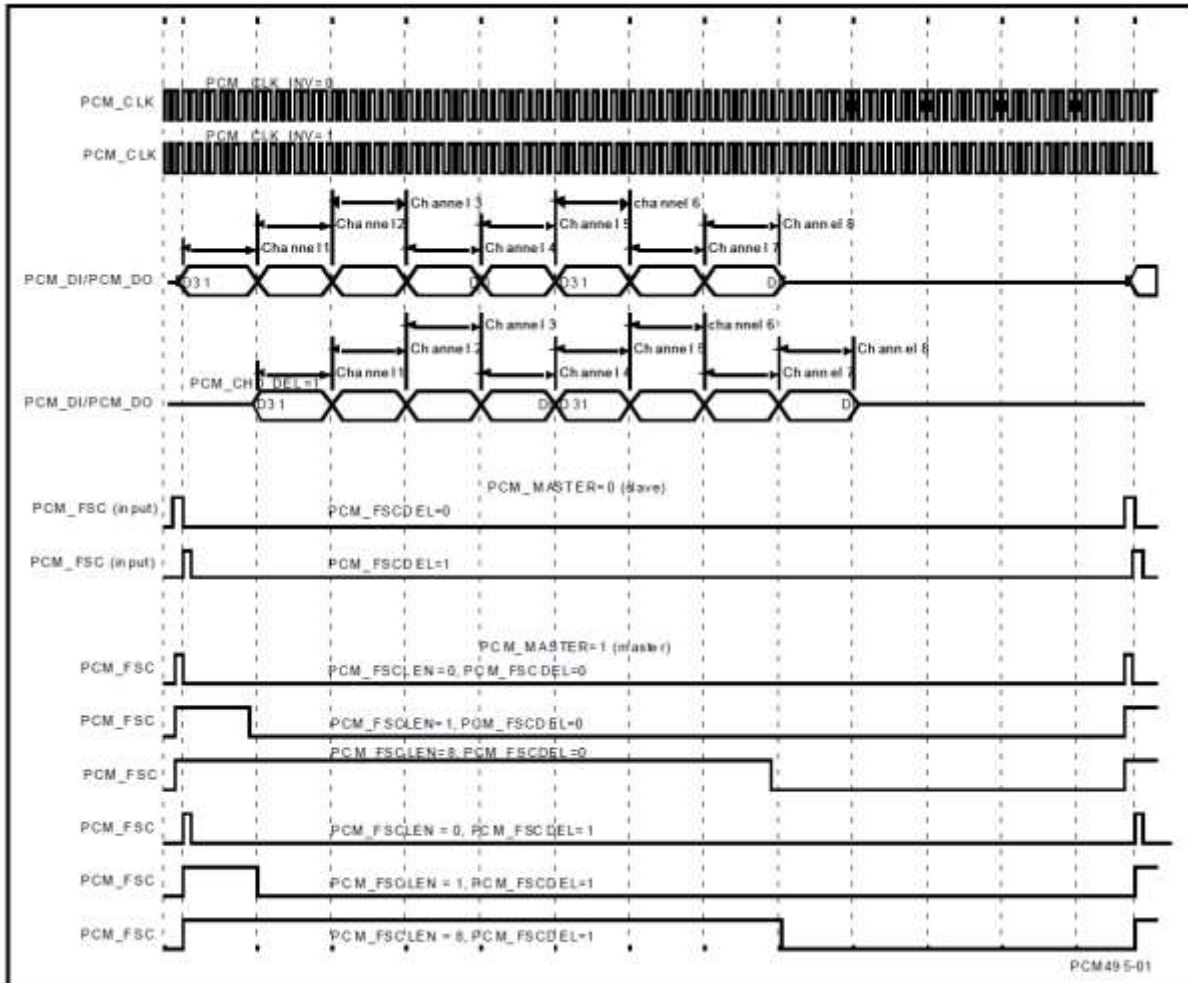

Figure 64. PCM interface formats

29.2.3.4.3 I2S Formats

The digital audio interface supports I2S mode, Left Justified mode, Right Justified mode and TDM mode.

I2S mode

To support I2S mode, the MSB of the right channel is valid on the second rising edge of the bit clock after the rising edge of the PCM_FSC, and the MSB of the left channel is valid on the second rising edge of the bit clock after the falling edge of the PCM_FSC.

Settings for I2S mode:

- PCM_FSC_EDGE: 1 (all after PCM_FSC)
- PCM_FSCLEN: 4 (4x8 High, 4x8 Low)
- PCM_FSC_DEL: 0 (one bit delayed)
- PCM_CLK_INV: 1 (output on falling edge)
- PCM_CH_DEL: 0 (no channel delay)

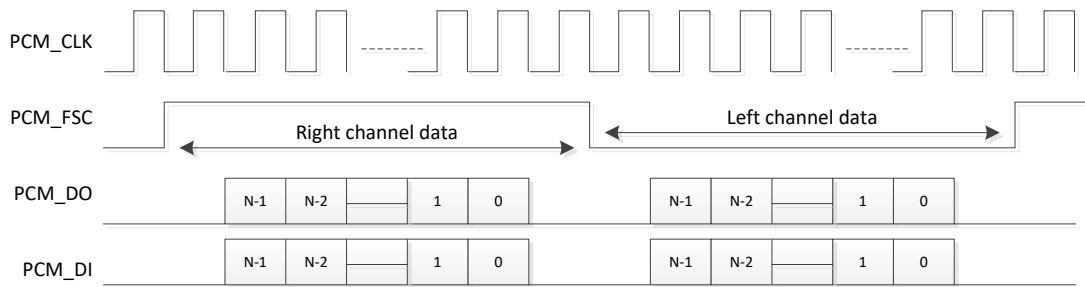

Figure 65. I2S mode

TDM mode

A time is specified from the normal 'start of frame' condition using register bits PCM_CH_DEL. In the left-justified TDM example illustrated in Figure 66, the left channel data is valid PCM_CH_DEL clock cycles, after the rising edge of the PCM_FSC, and the right channel data is valid the same PCM_CH_DEL number of clock cycles after the falling edge of the PCM_FSC.

By delaying the channels, left and right alignment can also be achieved.

Settings for TDM mode:

- PCM_FSC_EDGE: 1 (rising and falling PCM_FSC)
- PCM_FSCLLEN: Master 1 to 4
Slave waiting for edge
- PCM_FSC_DEL: 1 (no bit delay)
- PCM_CLK_INV: 1 (output on falling edge)
- PCM_CH0_DEL: Slave 0-31 (channel delay)
Master 1-3

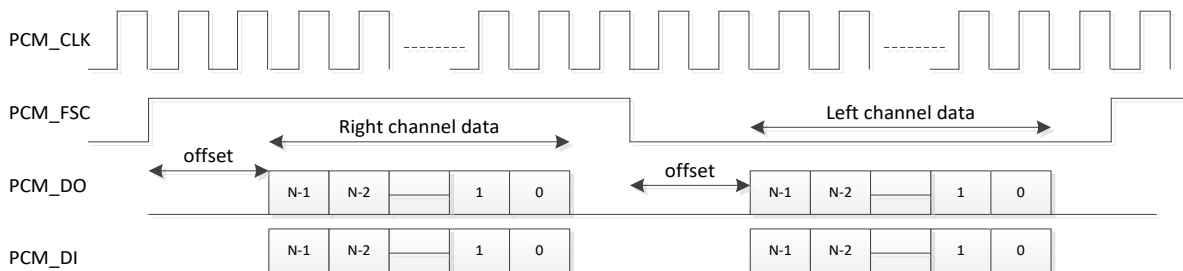

Figure 66. TDM mode (left justified mode)

Offset is always in multiples of 8.

IOM mode

In the IOM format, the PCM_CLK frequency is twice the data bit cell duration. In Slave mode, synchronization is on the first rising edge of PCM_FSC while data is clocked in on the second falling edge.

Settings for IOM mode:

- PCM_FSC_EDGE: 0 (rising edge PCM_FSC)
- PCM_FSCLLEN: 0 (one cycle)
- PCM_FSC_DEL: 1 (no bit delay)
- PCM_CLK_INV: 0 (output on rising edge)
- PCM_CH0_DEL: 0 (no delay)
- PCM_CLK_BIT: 1

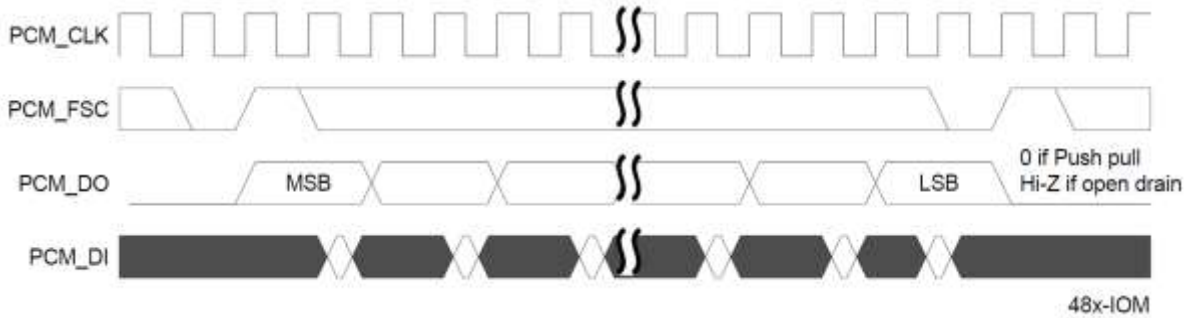

Figure 67. IOM format

29.2.4 PDM Interface

The PDM comprises two signals, namely the DATA and the CLK, and supports stereo streams. PDM_DATA is encoded so that the left channel is clocked in on the falling edge of CLK and the right channel is clocked on the rising edge of PDM_CLK as shown in Figure 68.

The interface supports MEMS microphone sleep mode by disabling the PDM_CLK. The PDM interface signals can be mapped on any GPIO by programming PID=32 and PID=33 for DATA and CLK respectively in the Px_yz_MODE_REG.

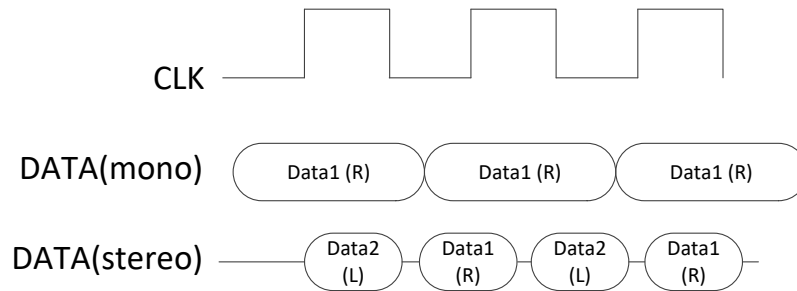

Figure 68. PDM Mono/Stereo formats

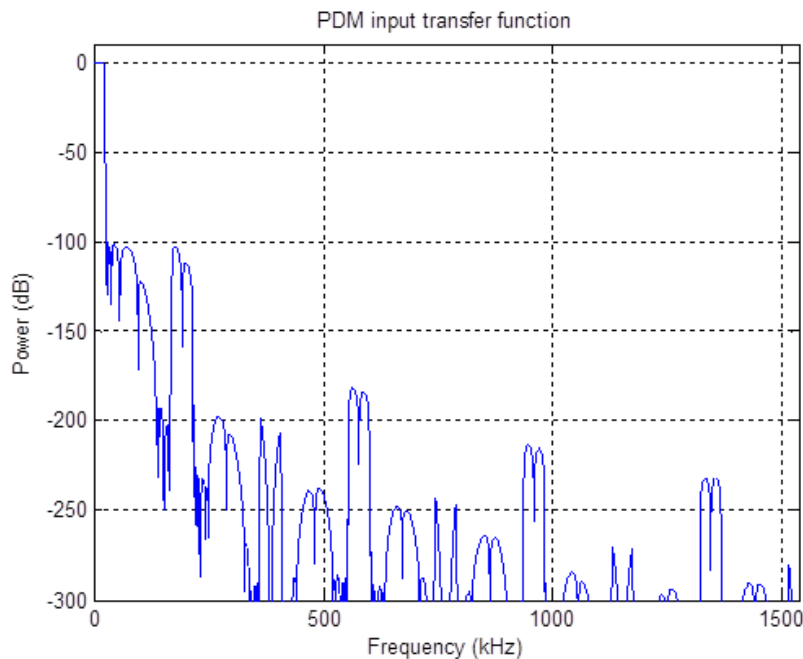

Figure 69. SRC PDM input transfer function

It should be noted that the audio quality degrades when the oversampling ratio is less than 64. For an 8 kHz sample rate the minimum recommended PDM clock rate is $64 \times 8 \text{ kHz} = 512 \text{ kHz}$.

29.2.5 DMA Support

If more than one sample needs to be transferred to or from the CPU, or the sample rate is so high that it interrupts the CPU too often, the DMA controller must be engaged to perform the transactions. Three channels are reserved in the DMA to support the PCM, the SRC (IN) and the SRC (OUT) directions.

29.2.6 Interrupts

After a Sample Rate Conversion, the input up-sampler and output down-sampler, generate edge triggered interrupts on SRC_IN_SYNC and SRC_OUT_SYNC to the CPU which do not have to be cleared. Note that only one sample shall be read from or written to a single register at a time (there are no FIFOs included).

29.3 Programming

29.3.1 PDM Input to PCM Output

There is a simple sequence of steps that needs to be followed to configure the Audio Unit:

1. Configure the GPIOs functionality used for the PDM and PCM I/F by writing the appropriate P_x_y_y_MODE_REG[PID] = 32,33 (PDM) and 28-31 (PCM).
2. Configure the GPIOs direction (P_x_y_y_MODE_REG[PUPD]).
3. Configure PDM I/F:
 - a. Configure as Master by setting the PDM_DIV_REG[PDM_MASTER_MODE] bit.
 - b. Set PDM clock divider (PDM_DIV_REG[PDM_DIV]).
 - c. Enable PDM (internal) block clock (PDM_DIV_REG[CLK_PDM_EN]).
4. Configure PCM I/F (Actual word size should be taken into consideration to calculate the values of PCM_FSC_DIV_REG and PCM_FSCLLEN):
 - a. Select the clock source (PCM_DIV_REG[PCM_SRC_SEL]).
 - b. Setup PCM clock division (PCM_DIV_REG[PCM_DIV], PCM_FDIV_REG).
 - c. Enable the clock (master mode) by setting the PCM_DIV_REG[CLK_PCM_EN] bit.
 - d. Disable PCM (PCM1_CTRL_REG[PCM_EN] = 0).
 - e. Set PCM Framesync divider (PCM1_CTRL_REG[PCM_FSC_DIV]).
 - f. (PCM1_CTRL_REG[PCM_FSC_EDGE]).
 - g. Set channel delay in multiples of 8 bits (PCM1_CTRL_REG[PCM_CH_DEL]).
 - h. Set the number of clock cycles per data bit (PCM1_CTRL_REG[PCM_CLK_BIT]).
 - i. Set polarity of PCM FSC (PCM1_CTRL_REG[PCM_FSCINV]).
 - j. Set polarity of PCM CLK (PCM1_CTRL_REG[PCM_CLKINV]).
 - k. Set PCM DO output mode (PCM1_CTRL_REG[PCM_PPOD]).
 - l. Set PCM FSC start time (PCM1_CTRL_REG[PCM_FSCDEL]).
 - m. Set PCM FSC data length (PCM1_CTRL_REG[PCM_FSCLLEN]).
 - n. Set PCM in Master mode (PCM1_CTRL_REG[PCM_MASTER] = 1).
5. Configure the Sample Rate Converter:
 - a. Set the SRC clock divider (SRC_DIV_REG[SRC_DIV]).
 - b. Enable the SRC block clock by setting the SRC_DIV_REG[CLK_SRC_EN] bit.
 - c. Select the SRC input Up Sampling IIR filters setting according to the sample rate (SRC1_CTRL_REG[SRC_IN_DS]).
 - d. Configure the SRC input sample rate (SRC1_IN_FS_REG).
 - e. Select the SRC output Up Sampling IIR filters setting according to the sample rate (SRC1_CTRL_REG[SRC_OUT_US]).
 - f. Configure the SRC output sample rate (SRC1_OUT_FS_REG).
 - g. Select the PDM as input to SRC (APU_MUX_REG[PDM1_MUX_IN] = 1).

- h. Enable the SRC FIFO (SRC1_CTRL_REG[SRC_FIFO_ENABLE]) and set direction (SRC1_CTRL_REG[SRC_FIFO_DIRECTION] = 1). Note that in stereo mode, FIFO cannot be used!
 - i. Select the output to PCM (APU_MUX_REG[PCM1_MUX_IN] = 1).
 - j. Set APU_MUX_REG[SRC1_MUX_IN] = 0.
 - k. Set SRC input to Automatic conversion mode (SRC1_CTRL_REG[SRC_IN_AMODE] = 1).
6. Enable SRC (SRC1_CTRL_REG[SRC_EN] = 1).
7. Enable PCM (PCM1_CTRL_REG[PCM_EN] = 1).

30. I2C Interface

Device:	DA14691	DA14695	DA14697	DA14699
Feature Availability:	✓	✓	✓	✓

30.1 Introduction

The I2C Interface is a programmable control bus that provides support for the communications link between Integrated Circuits in a system. It is a simple two-wire bus with a software-defined protocol for system control, which is used in temperature sensors and voltage level translators to EEPROMs, general-purpose I/O, A/D and D/A converters. It comprises 32 levels deep in both directions.

Features

- Two-wire I2C serial interface consists of a serial data line (SDA) and a serial clock (SCL)
- Three speeds are supported:
 - Standard mode (0 to 100 kbit/s)
 - Fast mode (<= 400 kbit/s)
 - High Speed mode (<= 3.4 Mbit/s)
- Clock synchronization
- 32 locations deep transmit/receive FIFOs (32 x 8-bit Rx, 32 x 10-bit Tx)
- Master transmit, Master receive operation
- 7-bit or 10-bit addressing
- 7-bit or 10-bit combined format transfers
- Bulk transmit mode
- Default slave address of 0x055
- Interrupt or polled-mode operation
- Handles Bit and Byte waiting at both bus speeds
- Programmable SDA hold time
- DMA support.

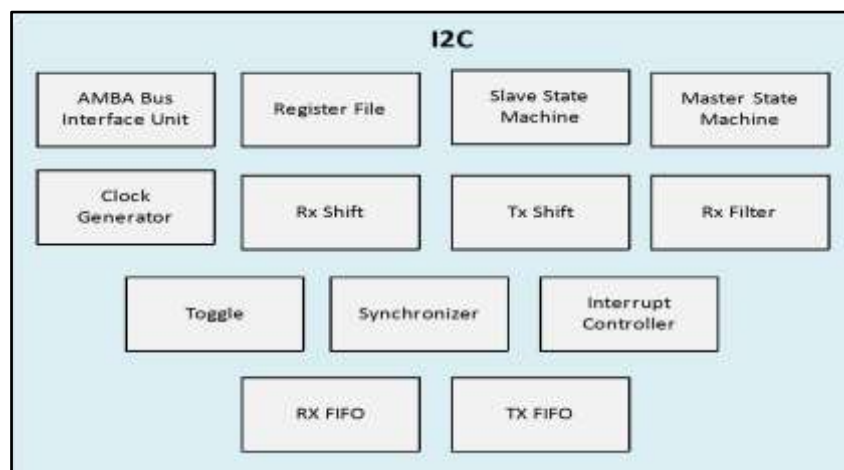

Figure 70. I2C Controller block diagram

The I2C Controller block diagram is shown in [Figure 70](#). It contains the following subblocks:

- AMBA Bus Interface Unit. Interfacing through the APB interface to access the register file
- Register File. Contains configuration registers and is the interface with software
- Master State Machine. Generates the I2C protocol for the master transfers
- Clock Generator. Calculates the required timing to do the following:
 - Generate the SCL clock when configured as a master

- Check for bus idle
- Generate a START and a STOP
- Setup the data and hold the data
- Rx Shift. Takes data into the design and extracts it in byte format
- Tx Shift. Presents data supplied by CPU for transfer on the I2C bus
- Rx Filter. Detects the events in the bus; for example, start, stop and arbitration lost
- Toggle. Generates pulses on both sides and toggles to transfer signals across clock domains
- Synchronizer. Transfers signals from one clock domain to another
- Interrupt Controller. Generates the raw interrupt and interrupt flags, allowing them to be set and cleared
- RX FIFO/TX. Holds the RX FIFO and TX FIFO register banks and controllers, along with their status levels.

30.2 Architecture

30.2.1 I2C Behavior

The I2C can be controlled (through software) to be a I2C master only, communicating with other I2C slaves

The master is responsible for generating the clock and controlling the transfer of data. The slave is responsible for transmitting or receiving data to and from the master. Data acknowledgement is sent by the device that receives data, which can be master or slave. The I2C protocol allows multiple masters to reside on the I2C bus. It uses an arbitration procedure to determine bus ownership.

Each slave has a unique address that is determined by the system designer. When a master wants to communicate with a slave, the master transmits a START/RESTART condition that is then followed by the slave's address and a control bit (R/W) to determine if the master wants to transmit data or receive data from the slave. The slave then sends an acknowledge pulse (ACK) after the address.

If the master (master-transmitter) is writing to the slave (slave-receiver), the receiver gets one byte of data. This transaction continues until the master terminates the transmission with a STOP condition. If the master is reading from a slave (master-receiver), the slave transmits (slave-transmitter) a byte of data to the master, and the master then acknowledges the transaction with the ACK pulse. This transaction continues until the master terminates the transmission by not acknowledging (NACK) the transaction after the last byte is received, and then the master issues a STOP condition or addresses another slave after issuing a RESTART condition. This behavior is illustrated in [Figure 71](#).

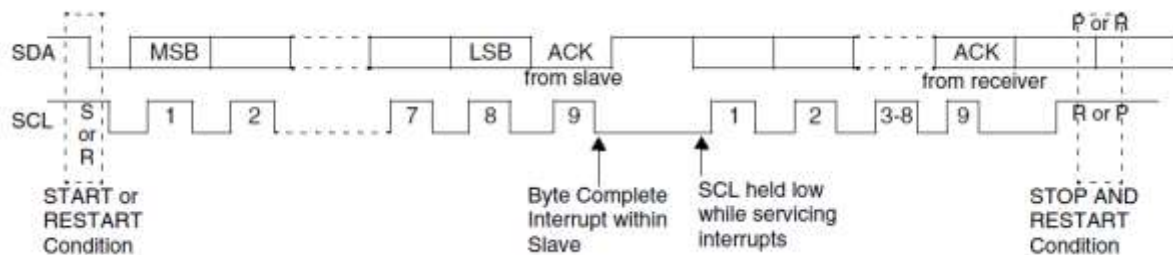

Figure 71. Data transfer on the I2C bus

The I2C is a synchronous serial interface. The SDA line is a bidirectional signal and changes only while the SCL line is low, except for STOP, START, and RESTART conditions. The output drivers are open-drain or open-collector to perform wire-AND functions on the bus. The maximum number of devices on the bus is limited by only the maximum capacitance specification of 400 pF. Data is transmitted in byte packages.

30.2.1.1 START and STOP Generation

When operating as an I2C master, putting data into the transmit FIFO causes the I2C Controller to generate a START condition on the I2C bus. Writing a 1 to I2C_DATA_CMD_REG[9] causes the i2c to generate a STOP condition on the I2C bus; a STOP condition is not issued if this bit is not set, even if the transmit FIFO is empty.

When operating as a slave, the I2C Controller does not generate START and STOP conditions, as per the protocol. However, if a read request is made to the I2C Controller, it holds the SCL line low until read data has

been supplied to it. This stalls the I2C bus until read data is provided to the slave I2C Controller, or the I2C Controller slave is disabled by writing a 0 to I2C_ENABLE.

30.2.1.2 Combined Formats

The I2C Controller supports mixed read and write combined format transactions in both 7-bit and 10-bit addressing modes.

The I2C Controller does not support mixed address and mixed address format - that is, a 7-bit address transaction followed by a 10-bit address transaction or vice versa - combined format transactions.

To initiate combined format transfers, I2C_CON.I2C_RESTART_EN should be set to 1. With this value set and operating as a master, when the I2C Controller completes an I2C transfer, it checks the transmit FIFO and executes the next transfer. If the direction of this transfer differs from the previous transfer, the combined format is used to issue the transfer. If the transmit FIFO is empty when the current I2C transfer completes, a STOP is issued, and the next transfer is issued following a START condition.

30.2.2 I2C Protocols

The I2C Controller has the following protocols:

- START and STOP Conditions
- Addressing Slave Protocol
- Transmitting and Receiving Protocol
- START BYTE Transfer Protocol.

30.2.2.1 START and STOP Conditions

When the bus is idle, both the SCL and SDA signals are pulled high through external pull-up resistors on the bus. When the master wants to start a transmission on the bus, the master issues a START condition. This is defined to be a high-to-low transition of the SDA signal while SCL is 1. When the master wants to terminate the transmission, the master issues a STOP condition. This is defined to be a low-to-high transition of the SDA line while SCL is 1. [Figure 72](#) shows the timing of the START and STOP conditions. When data is being transmitted on the bus, the SDA line must be stable when SCL is 1.

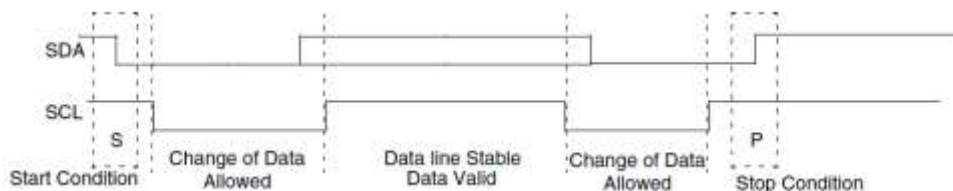

Figure 72. START and STOP conditions

Note: The signal transitions for the START/STOP conditions, as depicted in [Figure 72](#), reflect those observed at the output signals of the Master driving the I2C bus. Care should be taken when observing the SDA/SCL signals at the input signals of the Slave(s), because unequal line delays may result in an incorrect SDA/SCL timing relationship.

30.2.2.2 Addressing Slave Protocol

There are two address formats: 7-bit address format and 10-bit address format.

7-bit Address Format

During the 7-bit address format, the first seven bits (bits 7:1) of the first byte set the slave address and the LSB bit (bit 0) is the R/W bit as shown in [Figure 73](#). When bit 0 (R/W) is set to 0, the master writes to the slave. When bit 0 (R/W) is set to 1, the master reads from the slave.

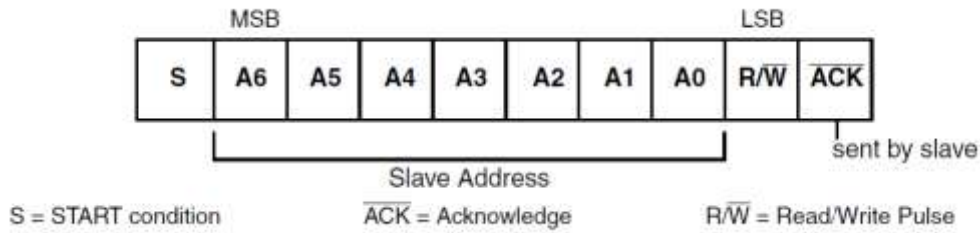

Figure 73. 7-bit address format

10-bit Address Format

During 10-bit addressing, two bytes are transferred to set the 10-bit address. The transfer of the first byte contains the following bit definition. The first five bits (bits 7:3) notify the slaves that this is a 10-bit transfer followed by the next two bits (bits 2:1), which set the slaves address bits 9:8, and the LSB bit (bit 0) is the R/W bit. The second byte transferred sets bits 7:0 of the slave address. Figure 74 shows the 10-bit address format, and Table 139 defines the special purpose and reserved first byte addresses.

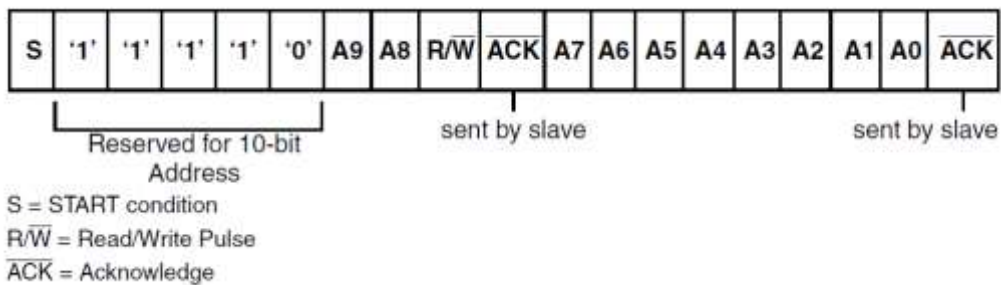

Figure 74. 10-bit address format

Table 139: I2C definition of bits in first byte

Slave address	R/W bits	Description
0000 000	0	General Call Address. I2C Controller places the data in the receive buffer and issues a General Call interrupt.
0000 000	1	START byte. For more details, refer to “START BYTE Transfer Protocol” 0000
0000 001	X	CBUS address. I2C Controller ignores these accesses
0000 010	X	Reserved
0000 011	X	Reserved
0000 1XX	X	High-speed master code (for more information, refer to “Multiple Master Arbitration”
1111 1XX	X	Reserved
1111 0XX	X	10-bit slave addressing

The I2C Controller does not restrict you from using these reserved addresses. However, if you use these reserved addresses, you may run into incompatibilities with other I2C components.

30.2.2.3 Transmitting and Receiving Protocols

The master can initiate data transmission and reception to/from the bus, acting as either a master-transmitter or master-receiver. A slave responds to requests from the master to either transmit data or receive data to/from the bus, acting as either a slave-transmitter or slave-receiver, respectively.

Master-Transmitter and Slave-Receiver

All data is transmitted in byte format, with no limit on the number of bytes transferred per data transfer. After the master sends the address and R/W bit or the master transmits a byte of data to the slave, the slave-receiver must respond with the acknowledge signal (ACK). When a slave-receiver does not respond with an ACK pulse, the master aborts the transfer by issuing a STOP condition. The slave must leave the SDA line high so that the master can abort the transfer.

If the master-transmitter is transmitting data as shown in Figure 75, then the slave-receiver responds to the master-transmitter with an acknowledge pulse after every byte of data is received.

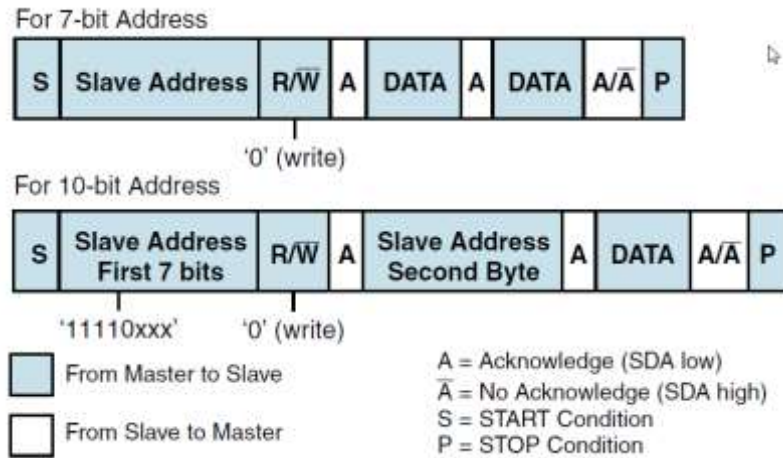

Figure 75. Master-Transmitter protocol

Master-Receiver and Slave-Transmitter

If the master is receiving data as shown in Figure 76 then the master responds to the slave-transmitter with an acknowledge pulse after a byte of data has been received, except for the last byte. This is the way the master-receiver notifies the slave-transmitter that this is the last byte. The slave-transmitter relinquishes the SDA line after detecting the No Acknowledge (NACK) so that the master can issue a STOP condition.

When a master does not want to relinquish the bus with a STOP condition, the master can issue a RESTART condition. This is identical to a START condition except it occurs after the ACK pulse. The master can then communicate with the same slave or a different slave.

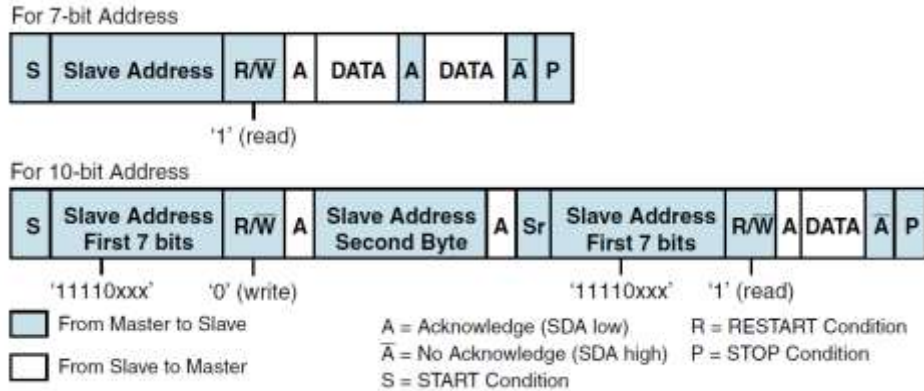

Figure 76. Master-Receiver protocol

START BYTE Transfer Protocol

The START BYTE transfer protocol is set up for systems that do not have an on-board dedicated I2C hardware module. When the I2C Controller is addressed as a slave, it always samples the I2C bus at the highest speed supported so that it never requires a START BYTE transfer. However, when I2C Controller is a master, it supports the generation of START BYTE transfers at the beginning of every transfer in case a slave device requires it. This protocol consists of seven zeros being transmitted followed by a 1, as illustrated in Figure 77. This allows the processor that is polling the bus to under-sample the address phase until 0 is detected. Once the microcontroller detects a 0, it switches from the under-sampling rate to the correct rate of the master.

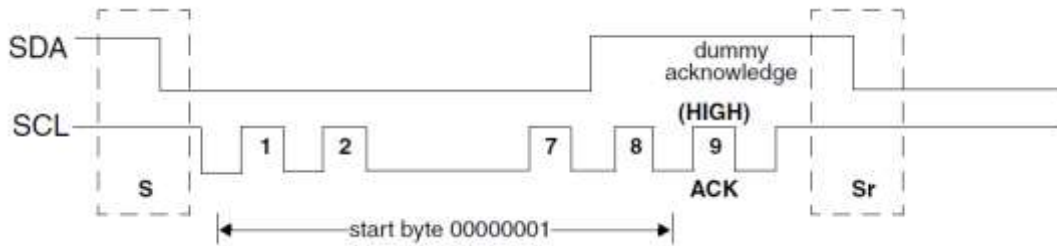

Figure 77. START BYTE transfer

The START BYTE procedure is as follows:

1. Master generates a START condition.
2. Master transmits the START byte (0000 0001).
3. Master transmits the ACK clock pulse. (Present only to conform with the byte handling format used on the bus)
4. No slave sets the ACK signal to 0.
5. Master generates a RESTART (R) condition.

A hardware receiver does not respond to the START BYTE because it is a reserved address and resets after the RESTART condition is generated.

30.2.3 Multiple Master Arbitration

The I2C Controller bus protocol allows multiple masters to reside on the same bus. If there are two masters on the same I2C-bus, there is an arbitration procedure if both try to take control of the bus at the same time by generating a START condition at the same time. Once a master (for example, a microcontroller) has control of the bus, no other master can take control until the first master sends a STOP condition and places the bus in an idle state.

Arbitration takes place on the SDA line, while the SCL line is 1. The master, which transmits a 1 while the other master transmits 0, loses arbitration and turns off its data output stage. The master that lost arbitration can continue to generate clocks until the end of the byte transfer. If both masters are addressing the same slave device, the arbitration could go into the data phase. [Figure 78](#) illustrates the timing of when two masters are arbitrating on the bus.

For high-speed mode, the arbitration cannot go into the data phase because each master is programmed with a unique high-speed master code. This 8-bit code is defined by the system designer and is set by writing to the High-Speed Master Mode Code Address Register, I2C_HS_MADDR. Because the codes are unique, only one master can win arbitration, which occurs by the end of the transmission of the high-speed master code.

Control of the bus is determined by address or master code and data sent by competing masters, so there is no central master or any order of priority on the bus.

Arbitration is not allowed between the following conditions:

- A RESTART condition and a data bit
- A STOP condition and a data bit
- A RESTART condition and a STOP condition.

Slaves are not involved in the arbitration process.

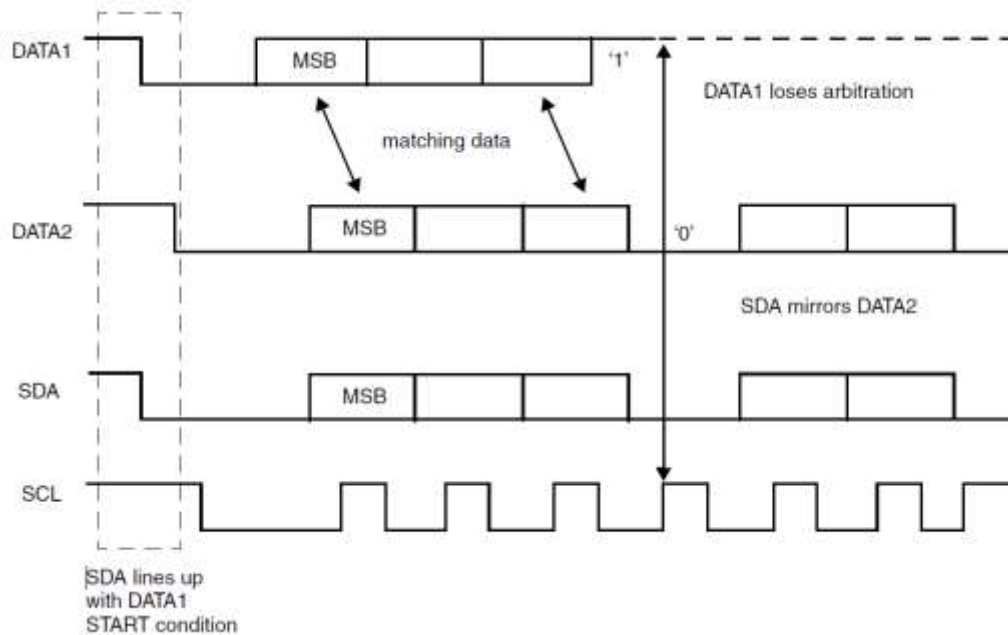

Figure 78. Multiple Master arbitration

30.2.4 Clock Synchronization

When two or more masters try to transfer information on the bus at the same time, they must arbitrate and synchronize the SCL clock. All masters generate their own clock to transfer messages. Data is valid only during the high period of SCL clock. Clock synchronization is performed using the wired-AND connection to the SCL signal. When the master transitions the SCL clock to 0, the master starts counting the low time of the SCL clock and transitions the SCL clock signal to 1 at the beginning of the next clock period. However, if another master is holding the SCL line to 0, then the master goes into a HIGH wait state until the SCL clock line transitions to 1.

All masters then count off their high time, and the master with the shortest high time, transitions the SCL line to 0. The masters then count out their low time. The one with the longest low time, forces the other master into a HIGH wait state. Therefore, a synchronized SCL clock is generated, which is illustrated in Figure 79. Optionally, slaves may hold the SCL line low, to slow down the timing on the I2C bus.

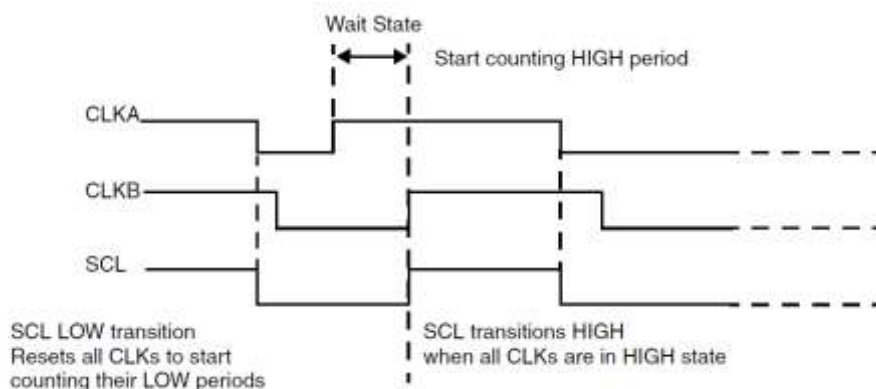

Figure 79. Multiple Master clock synchronization

30.3 Programming

There is a simple sequence of steps that needs to be followed to configure and use the I2C Controllers:

1. Set up the GPIOs to be used for the I2C interface ($Px_yy_MODE_REG[PID] = 21$ to 24).
2. Configure I2C clock frequency.
For $CLK_COM_REG[I2Cx_CLK_SEL] = 0$ (DivN clock):
 - a. Standard mode (100 kbit/s) : $I2Cx_CON_REG[I2C_SPEED] = 1$.

- b. Full speed mode (400 kbits/s) : I2Cx_CON_REG[I2C_SPEED] = 2.
- c. High speed mode (1 Mbit/s) : I2C_CON_REG[I2C_SPEED] = 3.
3. Set up the Controller as:
 - a. Master: I2Cx_CON_REG[I2C_MASTER_MODE] = 1 and I2Cx_CON_REG[I2C_SLAVE_DISABLE] = 1.
 - b. Slave: I2Cx_CON_REG[I2C_MASTER_MODE] = 0 and I2Cx_CON_REG[I2C_SLAVE_DISABLE] = 0.
4. Choose whether the controller starts its transfers in 7 or 10-bit addressing mode when acting as a master (I2Cx_CON_REG[I2C_10BITADDR_MASTER]) or when acting as a slave, whether the controller responds to 7- or 10-bit addresses (I2Cx_CON_REG[I2C_10BITADDR_SLAVE]).
5. Set target slave address in:
 - a. Master mode (I2Cx_TAR_REG[IC_TAR] = 0x55 (default)).
 - b. Slave mode (I2Cx_SAR_REG[IC_SAR] = 0x55 (default)).
6. Set threshold level on RX and TX FIFO (I2Cx_RX_TL_REG, I2Cx_TX_TL_REG).
7. Enable the required interrupts (I2Cx_INTR_MASK_REG).
8. Enable the I2C Controller by setting the CLK_COM_REG[I2Cx_ENABLE] bit.
9. Read a byte:
 - a. Prepare to transmit the read command byte (I2Cx_DATA_CMD_REG[I2C_CMD] = 1).
 - b. Wait until TX FIFO is empty (I2Cx_STATUS_REG[TFE] = 1).
 - c. Wait until master has finished reading the byte from slave device (I2Cx_STATUS_REG[MST_ACTIVITY] = 0).
10. Write a byte:
 - a. Prepare to transmit the write command byte (I2Cx_DATA_CMD_REG[I2C_CMD] = 0 and I2Cx_DATA_CMD_REG[I2C_DAT] = command byte).
 - b. Wait until TX FIFO is empty (I2Cx_STATUS_REG[TFE] = 1).
 - c. Wait until master has finished reading the response byte from slave device (I2Cx_STATUS_REG[MST_ACTIVITY] = 0).

31. UART

Device:	DA14691	DA14695	DA14697	DA14699
Feature Availability:	✓	✓	✓	✓

31.1 Introduction

The DA1469x contains three instances of this block. These are: UART, UART2, and UART3.

The UART is compliant to industry-standard 16550 and is used for serial communication with a peripheral. Data is written from a master (CPU) over the APB bus to the UART. It is converted to serial form and transmitted to the destination device. Serial data is also received by the UART and stored for the master (CPU) to read back.

There is also DMA support on the UART block, so the internal FIFOs can be used. UART2 and UART3 support hardware flow control signals (RTS, CTS).

Features

- Dedicated 16 bytes Transmit and 16 B Receive FIFO for each UART
- Hardware flow control and 9-bit mode support (CTS/RTS, UART2 and UART3)
- Shadow registers reduces software overhead and include a software programmable reset
- Transmitter Holding Register Empty (THRE) interrupt mode
- Functionality based on 16550 industry standard:
 - Programmable character properties, such as number of data bits per character (5-8)
 - Optional parity bit (with odd or even select) and number of stop bits (1, 1.5 or 2)
 - Line break generation and detection
 - Prioritized interrupt identification
- Programmable serial data baud rate as calculated by the following: $\text{baud rate} = (\text{serial clock frequency}) / (16 \times \text{divisor})$ and the fractional part $\text{UART_DLF}/16$
- ISO7816 support (UART3).

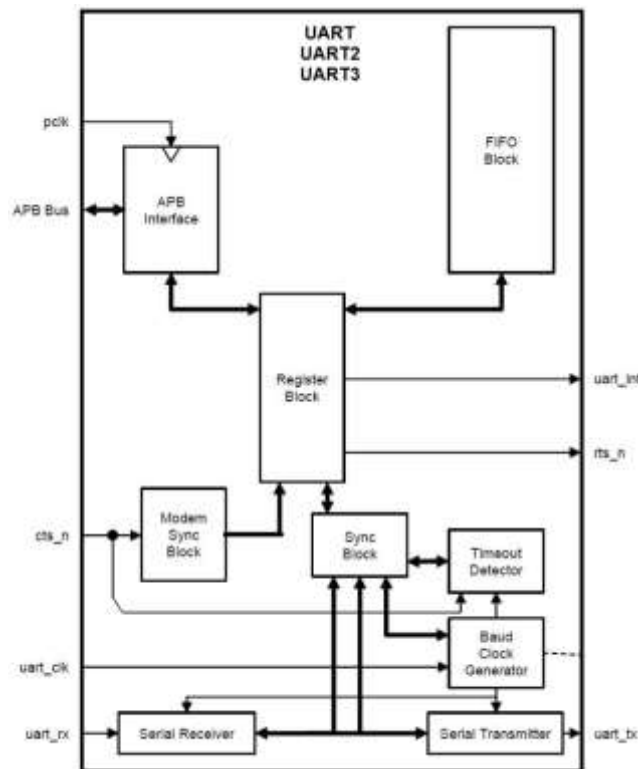

Figure 80. UART block diagram

31.2 Architecture

31.2.1 UART (RS232) Serial Protocol

Because the serial communication between the UART and the selected device is asynchronous, additional bits (start and stop) are added to the serial data to indicate the beginning and end. Utilizing these bits allows two devices to be synchronized. This structure of serial data accompanied by start and stop bits is referred to as a character, as shown in [Figure 81](#).

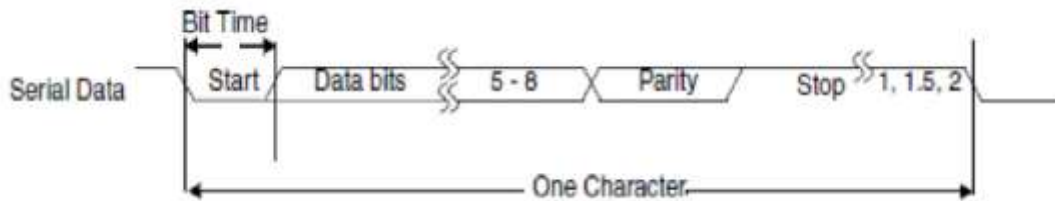

Figure 81. Serial data format

An additional parity bit may be added to the serial character. This bit appears after the last data bit, but before the stop bit(s) in the character structure. It provides the UART with the ability to perform simple error checking on the received data.

The UART Line Control Register (UART_LCR_REG) is used to control the serial character characteristics. The individual bits of the data word are sent after the start bit, starting with the least-significant bit (LSB). These are followed by the optional parity bit, followed by the stop bit(s), which can be 1, 1.5, or 2.

All the bits in the transmission (with exception of the half-stop bit when 1.5 stop bits are used) are transmitted for exactly the same time duration. This is referred to as a Bit Period or Bit Time. One Bit Time equals 16 baud clocks. To ensure stability on the line, the receiver samples the serial input data at approximately the mid-point of the Bit Time, once the start bit has been detected. As the exact number of baud clocks that each bit was transmitted for is known, calculating the mid-point for sampling is not difficult, that is every 16 baud clocks after the mid-point sample of the start bit. [Figure 82](#) shows the sampling points of the first couple of bits in a serial character.

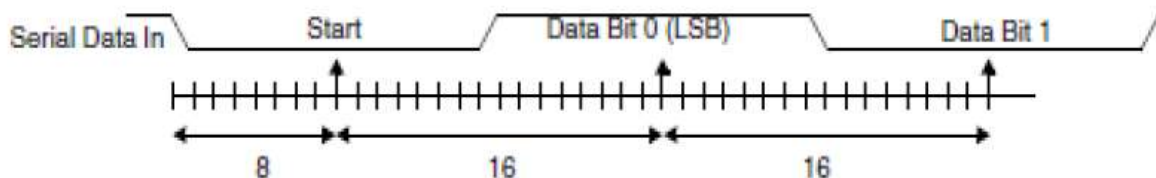

Figure 82. Receiver serial data sampling points

As part of the 16550 standard, an optional baud clock reference output signal (baudout_n) is supplied to provide timing information to receiving devices that require it. The baud rate of the UART is controlled by the serial clock (*sclk* or *pclk* in a single clock implementation) and the Divisor Latch Register (DLH and DLL). The registers settings for common baud rate values are presented in the following tables:

Table 140: UART baud rate generation

Baud rate (Note 2)	Divider	Divisor latch	DLH reg	DLL reg	DLF reg	Actual BR	Error %
1200	1666.667	1666.6875	6	130	11	1199.99	0.00
2400	833.333	833.3125	3	65	5	2400.06	0.00
4800	416.667	416.6875	1	160	11	4799.76	0.00
9600	208.333	208.3125	0	208	5	9600.96	0.01
14400	138.889	138.875	0	138	14	14401.44	0.01
19200	104.167	104.1875	0	104	3	19196.16	0.02
28800	69.444	69.4375	0	69	7	28802.88	0.01
38400	52.083	52.0625	0	52	1	38415.37	0.04

Baud rate (Note 2)	Divider	Divisor latch	DLH reg	DLL reg	DLF reg	Actual BR	Error %
57600	34.722	34.75	0	34	12	57553.96	0.08
115200	17.361	17.375	0	17	6	115107.91	0.08
230400	8.681	8.6875	0	8	11	230215.83	0.08
460800	4.340	4.3125	0	4	5	463768.12	0.64
921600	2.170	2.1875	0	2	3	914285.71	0.79
1000000	2	2	0	2	0	1000000	0.00

Note 2 Values are valid for UART CLK = 32 MHz (divN_clk).

Table 141: UART2/3 baud rate generation

Baud rate (Note 1)	Divider	Divisor latch	DLH reg	DLL reg	DLF reg	Actual BR	Error %
1200	5000.000	5000	19	136	0	1200.00	0.00
2400	2500.000	2500	9	196	0	2400.00	0.00
4800	1250.000	1250	4	226	0	4800.00	0.00
9600	625.000	625	2	113	0	9600.00	0.00
14400	416.667	416.6875	1	160	11	14399.28	0.00
19200	312.500	312.5	1	56	8	19200.00	0.00
28800	208.333	208.3125	0	208	5	28802.88	0.01
38400	156.250	156.25	0	156	4	38400.00	0.00
57600	104.167	104.1875	0	104	3	57588.48	0.02
115200	52.083	52.0625	0	52	1	115246.10	0.04
230400	26.042	26.0625	0	26	1	230215.83	0.08
460800	13.021	13	0	13	0	461538.46	0.16
921600	6.510	6.5	0	6	8	923076.92	0.16
1000000	6	6	0	6	0	1000000	0.00
3000000	2	2	0	2	0	3000000	0.00

Note 1 Values are valid for CLK_COM_REG[UART2/3_CLK_SEL] = 1 and sys_clk = 96 MHz. For CLK_COM_REG[UART2/3_CLK_SEL] = 0, see [Table 140](#).

31.2.2 Clock Support

The UART has two system clocks (*pclk* and *sclk*). Having the second asynchronous serial clock (*sclk*) implemented, accommodates accurate serial baud rate settings, as well as APB bus interface requirements.

With the two-clock design, a synchronization module is implemented for synchronization of all control and data across the two system clock boundaries.

A serial clock faster than four-times the *pclk* does not leave enough time for a complete incoming character to be received and pushed into the receiver FIFO. However, in most cases, the *pclk* signal is faster than the serial clock and this should never be an issue.

The serial clock modules must have time to see new register values and reset their respective state machines. This total time is guaranteed to be no more than eight clock cycles of the slower of the two system clocks. Therefore, no data should be transmitted or received before this maximum time expires, after initial configuration.

31.2.3 Interrupts

The assertion of the UART interrupt (UART_INT) occurs whenever one of the several prioritized interrupt types are enabled and active. The following interrupt types can be enabled with the IER register:

- Receiver Error
- Receiver Data Available
- Character Timeout (in FIFO mode only)
- Transmitter Holding Register Empty at/below threshold (in Programmable THRE interrupt mode).

When an interrupt occurs, the master accesses the UART_IIR_REG to determine the source of the interrupt before dealing with it accordingly. These interrupt types are described in more detail in [Table 142](#).

Table 142: UART interrupt priorities

Interrupt ID Bits [3-0]	Interrupt set and reset functions			
	Priority	Interrupt type	Interrupt source	Interrupt reset control
0001	-	None		
0110	Highest	Receiver Line status	Overrun/parity/ framing errors or break interrupt	Reading the line status register
0100	1	Receiver Data Available	Receiver data available (non-FIFO mode or FIFOs disabled) or RCVR FIFO trigger level reached (FIFO mode and FIFOs enabled)	Reading the receiver buffer register (non-FIFO mode or FIFOs disabled) or the FIFO drops below the trigger level (FIFO mode and FIFOs enabled)
1100	2	Character timeout indication	No characters in or out of the RCVR FIFO during the last four character times and there is at least one character in it during this time.	Reading the receiver buffer register
0010	3	Transmitter holding register empty	Transmitter holding register empty (Prog. THRE Mode disabled) or XMIT FIFO at or below threshold (Prog. THRE Mode enabled).	Reading the IIR register (if source of interrupt); or, writing into THR (FIFOs or THRE Mode not selected or disabled) or XMIT FIFO above threshold (FIFOs and THRE Mode selected and enabled).
0000	4	Reserved	-	-
0111	Lowest	Busy detect	Line Control Register was written while the UART is busy (RX or TX line is low)	Reading the UART status register

31.2.4 Programmable THRE Interrupt

The UART can be configured to have a Programmable THRE Interrupt mode available to increase system performance.

When Programmable THRE Interrupt mode is selected, it can be enabled through the Interrupt Enable Register (IER[7]). When FIFOs and the THRE Mode are implemented and enabled, THRE Interrupts are active at, and below, a programmed transmitter FIFO empty threshold level, as opposed to empty, as shown in the flowchart in [Figure 83](#).

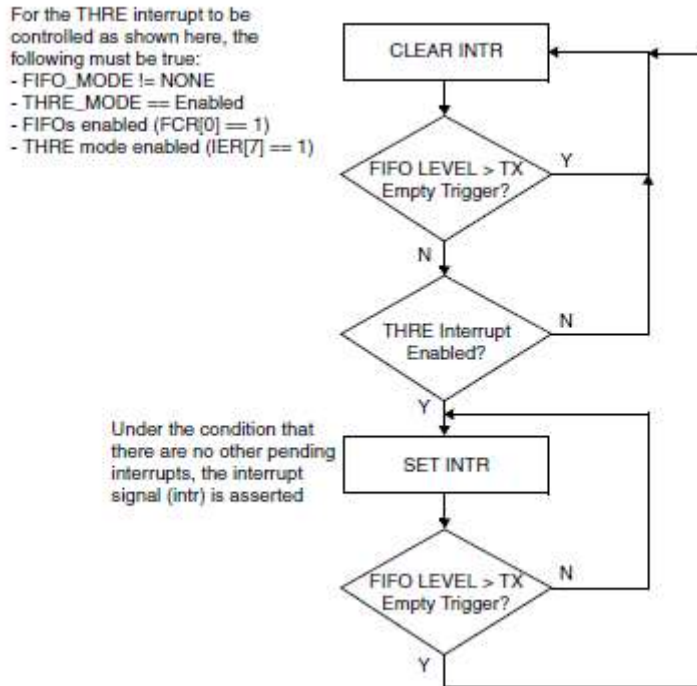

Figure 83. Flowchart of interrupt generation for programmable THRE Interrupt mode

This threshold level is programmed into FCR[5:4]. The available empty thresholds are: empty, 2, ¼ and ½. See UART_FCR_REG for threshold setting details. Selection of the best threshold value depends on the system's ability to begin a new transmission sequence in a timely manner. However, one of these thresholds should prove optimum in increasing system performance by preventing the transmitter FIFO from running empty.

In addition to the interrupt change, Line Status Register (LSR[5]) also switches function from indicating transmitter FIFO empty, to FIFO full. This allows software to fill the FIFO each transmit sequence, by polling LSR[5] before writing another character. The flow then becomes, “fill transmitter FIFO whenever an interrupt occurs and there is data to transmit”, instead of waiting until the FIFO is completely empty. Waiting until the FIFO is empty, causes a performance hit whenever the system is too busy to respond immediately.

Even if everything else is selected and enabled, if the FIFOs are disabled via FCR[0], the Programmable THRE Interrupt mode is also disabled. When not selected or disabled, THRE interrupts and LSR[5] function normally (both reflecting an empty THR or FIFO). The flowchart of THRE interrupt generation, when not in programmable THRE interrupt mode, is shown in [Figure 84](#).

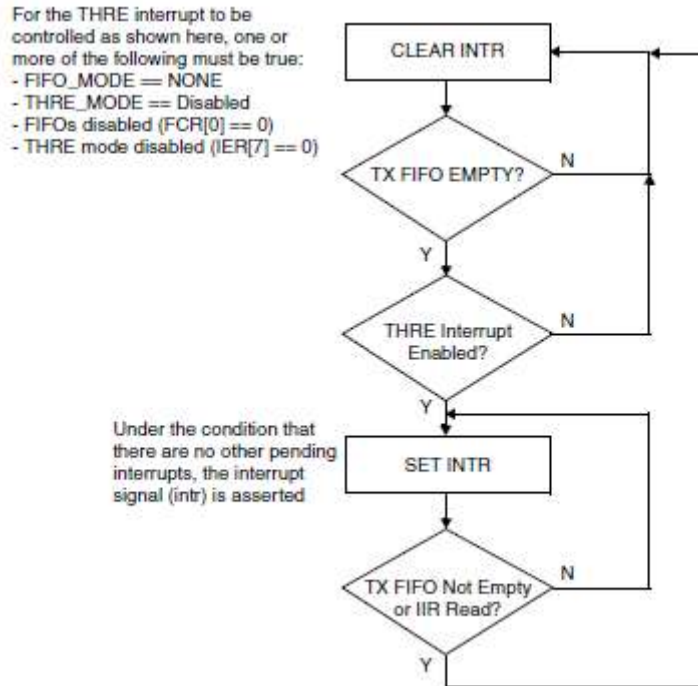

Figure 84. Flowchart of interrupt generation when not in programmable THRE Interrupt mode

31.2.5 Shadow Registers

The shadow registers *shadow* some of the existing register bits that are regularly modified by software. These can be used to reduce the software overhead that is introduced by having to perform read-modify-writes.

- UART_SRBR_REG support a host burst mode where the host increments its address, but still accesses the same Receive buffer register
- UART_STHR support a host burst mode where the host increments its address, but still accesses the same transmit holding register
- UART_SFE_REG accesses the FCR[0] register without accessing the other UART_FCR_REG bits
- UART_SRT_REG accesses the FCR[7-6] register without accessing the other UART_FCR_REG bits
- UART_STER_REG accesses the FCR[5-4] register without accessing the other UART_FCR_REG bits.

31.2.6 Direct Test Mode

The on-chip UARTs can be used for the Direct Test Mode required for the final product PHY layer testing. It can be done either over the HCI layer, which engages a full CTS/RTS UART or using a 2-wire UART directly as described in the *Bluetooth Low Energy Specification (Volume 6, Part F)*.

31.3 Programming

There is a simple sequence of steps that need to be followed to configure and use the UART controllers:

1. Set up the GPIOs to be used for the UART interface (Px_yy_MODE_REG[PID] = 1 to 10).
2. Select the UART clock (CLK_COM_REG[UART2/3_CLK_SEL]). This step is not needed when UART is used.
3. Enable the selected UART by setting the CLK_COM_REG[UARTx_ENABLE] bit.
4. Enable access to Divisor Latch Registers (DLL and DLH) by setting the UARTx_LCR_REG[UART_DLAB] bit.
5. Set the desired baud rate. To calculate the registers values for the desired baud rate, use the formula:

$$\text{Divisor} = \text{UART CLK} / (16 \times \text{Baud rate}).$$
 - a. UARTx_IER_DLH_REG: High byte of the Divisor integer part.
 - b. UARTx_RBR_THR_DLL_REG: Low byte of the Divisor integer part.

- c. UARTx_DLF_REG: The fractional part of the Divisor.
- 6. Configure the brake control bit, parity, number of stop bits and data length (UARTx_LCR_REG).
- 7. Enable and configure the FIFO (UARTx_IIR_FCR_REG).
- 8. Configure the generated interrupts, if needed (UARTx_IER_DLH_REG).
- 9. Send a byte:
 - a. Check if Transmit Hold Register (THR) is empty (UARTx_LSR_REG[UART_THRE]).
 - b. Load the byte to THR (UARTx_RBR_THR_DLL_REG).
 - c. Check if the byte was transmitted (UARTx_LSR_REG[UART_TEMT]).
- 10. Receive a byte:
 - a. Wait until serial data is ready (UARTx_LSR_REG[UART_DR]).
 - b. Read the incoming byte from the THR (UARTx_RBR_THR_DLL_REG).

32. Smart Card Interface

Device:	DA14691	DA14695	DA14697	DA14699
Feature Availability:	✓	✓	✓	✓

32.1 Introduction

The DA1469x features a Smart Card interface implemented using the UART3 block. The UART3 block supports asynchronous protocol smartcards as defined in the ISO 7816-3 (Class B and C) standard.

Features

- ISO/IEC 7816-3 (Class B and C) complaint
- UART Line with Flow Control Signals
- Interrupt line
- DMA support
- An Error signal support with indication for character repetition
- Inverse and direct convention
- Guard time.

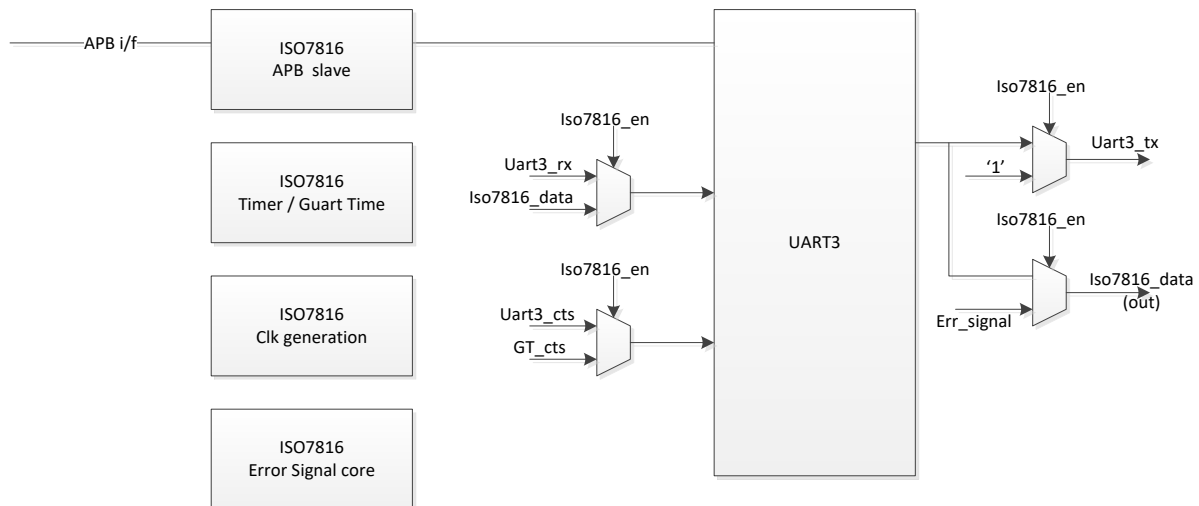

Figure 85. Smart Card (ISO7816-3) block diagram

32.2 Architecture

32.2.1 ISO7816-3 Clock Generation

The ISO7816-3 block operates on a system-based clock with a 50 % duty cycle. The clock frequency is calculated using the formula:

$$F_{SCLK} / [2 * (UART3_CTRL_REG[ISO7816_CLK_DIV] + 1)]$$

The UART3_CTRL_REG[ISO7816_CLK_DIV] value can be updated at any time, whether the ISO7816-3 clock is enabled or not. The operation of the clock can be checked at any given time by polling the UART3_CTRL_REG[ISO7816_CLK_STATUS] bit and disabled by clearing the ISO7816_CLK_EN[ISO7816_CLK_EN] bit. The UART3_CTRL_REG[ISO7816_CLK_LEVEL] reflects the logical level of the clock while it has been disabled.

32.2.2 ISO7816-3 Timer – Guard Time

The ISO7816-3 block is equipped with an ISO7816-3 Timer/Guard Timer and can operate in two modes:

- UART3_TIMER_REG[ISO7816_TIM_MODE] = 0.
The timer is clocked with the clock of the ISO7816 module and will start when

UART3_TIMER_REG[ISO7816_TIM_EN] = 1. It will count from 0 to UART3_TIMER_REG[ISO7816_TIM_MAX] value. The value of the timer can be read from UART3_TIMER_REG[ISO_TIM_MAX] register field.

At the point where the top value is reached, the timer will stop and the UART3_IRQ_STATUS_REG[ISO7816_TIM_EXPIRED_IRQ] will be set. If the UART3_CTRL_REG[ISO7816_TIM_EXPIRED_IRQMASK] is 1, an interrupt will be generated. The interrupt will be cleared when UART3_TIMER_REG[ISO7816_TIM_EN] is set.

- UART3_TIMER_REG[ISO7816_TIM_MODE] = 1.

The timer is clocked with the 1/16 of the UART bit clock (1/16 etu). If the UART fractional divider has been set, the 1/16 of the UART bit clock will not have a fixed value. If the UART3_TIMER_REG [ISO7816_TIM_EN] bit is set, the timer will start counting from 0 to UART3_TIMER_REG[ISO_TIM_MAX] value, each time a start bit is transmitted by the UART.

If the UART3_TIMER_REG[ISO_TIM_MAX] value is set equal to $16 * \text{GuarTime} - 1$, the timer will count the minimum delay between the leading edges of two consecutive characters (Guard time). In case of no FIFO mode and $GT > 12$ etu, the expiration of the timer indicates that the module is allowed to send the next character (Guard Time elapsed). In case of FIFO mode and $GT > 12$ etu, the UART3_CTRL_REG[ISO7816_AUTO_GT] bit can be set so the module will be able to send the next character automatically each time the Guard Time is reached.

32.2.3 ISO7816-3 Error Detection

The ISO7816-3 block is designed to support the functionality described in the Section 7.3 of ISO7816-3 specification document.

Transmit Phase

The transmitter checks the ISO7816 data level for 11etu sampling time after a character's leading edge is detected. The module samples the data line at 11etu time and creates two types of interrupts:

- The ISO7816_ERR_TX_TIME_IRQ interrupt is created each time a character is sent.
- The ISO7816_ERR_TX_VALUE_IRQ interrupt is created each time the receiver sends an error.

The software must check if an ISO7816_ERR_TX_VALUE_IRQ interrupt is generated to retransmit the character. The IRQs are generated at the same time.

Receive Phase

The receiver will hold the data line level Low between 1 etu (minimum) and 2 etu (maximum) at 10.5 etu time. The error detection circuit will use the UART parity check and create an error signal to the transmitter at the proper time. The error signal pulse width and offset can be configured using the UART3_ERR_CTRL_REG register. Furthermore, the ISO7816-3 block can hold the UART_Rx signal High during the error signal transmitting to prevent UART errors from happening.

32.3 Programming

There is a simple sequence of steps that needs to be followed to configure the Smart Card Controller:

1. Set up the GPIOs to be used for the ISO7816-3 interface (Px_yy_MODE_REG[PID] = 11 to 12). Reset (output) and card insert (input) signals shall be configured as GPIOs (Px_yy_MODE_REG[PID] = 0).
2. Enable UART3 by setting the CLK_COM_REG[UART3_ENABLE] bit.
3. Set up UART3 clock (CLK_COM_REG[UART3_CLK_SEL]).
4. Enable the ISO7816-3 module by setting the UART3_CONFIG_REG[ISO7816_ENABLE] bit.
5. Set up the ISO7816-3 clock (UART3_CTRL_REG[ISO7816_CLK_DIV]).
6. Initialize UART3 as follows:
 - a. Configure FIFO, if needed (UART3_IIR_FCR_REG, UART3_SRT_REG, UART3_STET_REG, UART3_SFE_REG). Note that if Error detection is enabled, the TX FIFO shall remain disabled.
 - b. Configure ISO7816 convention:
7. Select data length (UART3_LCR_REG[UART_DLS]):
 - i. Select the number of stop bits (UART3_LCR_REG[UART_STOP]).
 - ii. Enable/disable parity (UART3_LCR_REG[UART_PEN]).

- iii. Select even or odd parity (UART3_LCR_REG[UART_EPS]).
 - iv. If needed, enable Error detection (UART3_CONFIG_REG[ISO7816_ERR_SIG_EN]) and configure the error pulse width and offset (UART3_ERR_CTRL_REG).
 - v. Select direct/inverse convention (UART3_CONFIG_REG[ISO7816_CONVENTION]).
 - b. Configure the baud rate. To calculate the registers values for the desired baud rate, use the formula: $\text{Divisor} = F_i * (\text{ISO7816_CLK_DIV} + 1) / (8 * D_i)$. For F_i and D_i values, refer to ISO/IEC 7816-3 Standard Specification, table 7 and table 8:
 - i. Enable access to the Divisor Latch register: UART3_LCR_REG[UART_DLAB] = 1.
 - ii. Set the High byte of the Divisor integer part (UART3_IER_DLH_REG).
 - iii. Set the Low byte of the Divisor integer part (UART3_RBR_THR_DLL_REG).
 - iv. Set the fractional part of the Divisor (UART3_DLF_REG).
 - c. Configure the generated interrupts, if needed (UART3_CTRL_REG).
8. Send a byte:
- a. Set up the Guard Timer (UART3_TIMER_REG).
 - b. In case of TX FIFO is enabled, check if FIFO is full (UART3_USR_REG[UART_TFNF]) or check if Transmit Hold Register (THR) is empty (UART3_LSR_REG[UART_THRE]).
 - c. Load the byte to THR (UART3_RBR_THR_DLL_REG).
 - d. Check if the byte was transmitted (UART3_LSR_REG[UART_TEMT]).
9. Receive a byte:
- a. Set up the Wait Time (UART3_TIMER_REG).
 - b. Wait until serial data is ready (UART3_LSR_REG[UART_DR]) or timer expiration.
 - c. Read the received byte from the THR (UART3_RBR_THR_DLL_REG).

33. SPI+ Interface

Device:	DA14691	DA14695	DA14697	DA14699
Feature Availability:	✓	✓	✓	✓

33.1 Introduction

The DA1469x contains two instances of this block, namely, SPI and SPI2.

The SPI+ interface supports a subset of the Serial Peripheral Interface (SPI™). The serial interface can transmit and receive 8, 16, or 32 bits in master/slave mode and transmit 9 bits in master mode. The SPI+ interface has enhanced functionality with 8-byte RX and 4-byte TX FIFOs.

Features

- Slave and Master mode
- 8 bit, 9 bit, 16 bit or 32 bit operation
- Clock speeds up to 32 MHz for the SPI controller. Programmable output frequencies of SPI source clock divided by 2, 4, 8, 14
- SPI clock line speed up to 16 MHz
- SPI mode 0, 1, 2, 3 support (clock edge and phase)
- Programmable SPI_DO idle level
- Maskable Interrupt generation
- Bus load reduction by unidirectional writes-only and reads-only modes
- Dedicated 8-byte RX and 4-byte TX FIFOs for each SPI block
- DMA support.

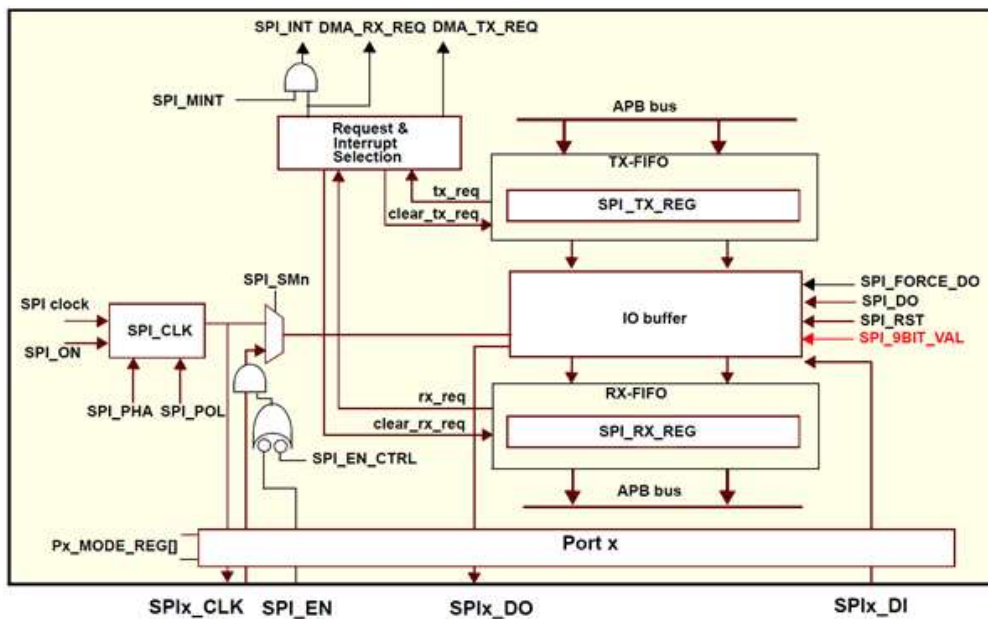

Figure 86. SPI block diagram

33.2 Architecture

33.2.1 Master Mode

This mode is the default mode. To enable SPITM operation, the individual port signal must first be enabled. Next, the SPI must be configured in SPI_CTRL_REG, for the desired mode. Finally, bit SPI_ON must be set to 1.

A SPI transfer cycle starts after writing to the SPI_RX_TX_REG. Writing to SPI_RX_TX_REG also sets the SPI_TXH. As soon as the holding register is copied to the IO buffer, the SPI_TXH is reset. Then a serial transfer cycle of 8/9/16/32 clock-cycles is started leading to 8/9/16/32 bits being transmitted on SPI_DO. Simultaneously, data is received on SPI_DI and shifted into the IO buffer. The transfer cycle finishes after the 8th/9th/16th/32nd clock cycle and SPI_INT_BIT bit is set in the SPI_CTRL_REG, and SPI_INT_PENDING bit in (RE)SET_INT_PENDING_REG is set. The received bits in the IO buffer are copied to the SPI_RX_TX_REG where they can be read by the CPU.

Interrupts to the CPU can be disabled using the SPI_MINT bit. To clear the SPI interrupt source, any value to SPI_CLEAR_INT_REG must be written. Take note that SPI_INT will be set if the RX-FIFO contains unread data.

33.2.2 Slave Mode

The slave mode is selected with SPI_SMn set to 1 and the Px_MODE_REG must also select SPI_CLK as input. The functionality of the IO buffer in slave and master mode is identical. The SPI module clocks data in from SPI_DI and out on SPI_DO on every active edge of SPI_CLK, as shown in [Figure 87](#). The SPI has an active low clock enable SPI_EN, which can be enabled with bit SPI_EN_CTRL=1.

In slave mode, the internal SPI clock must be four times greater than the SPI_CLK coming from the master. The SPI_EN serves as a clock enable and bit synchronization, if enabled with bit SPI_EN_CTRL. As soon as SPI_EN is deactivated between the MSB and LSB bits, the I/O buffer is reset.

33.2.3 SPI_POL and SPI_PHA

The phase and polarity of the serial clock can be changed with bits SPI_POL and SPI_PHA in the SPI_CTRL_REG.

33.2.4 SPI_DO Idle Levels

The idle level of signal SPI_DO depends on the master or slave mode, polarity and phase mode of the clock.

In master mode, pin SPI_DO gets the value of bit SPI_DO if the SPI is idle in all modes (mode 0 to 3). Also if slave is in SPI mode 0 or 2, then SPI_DO bit is the initial and final idle level.

In SPI modes 1 and 3, there is no clock edge after the sampled lsb and pin SPI_DO gets the lsb value of the IO buffer. If required, the SPI_DO can be forced to the SPI_DO bit level by resetting the SPI to the idle state. This is done by shortly setting bit SPI_RST to 1. (Optionally, SPI_FORCE_DO can be set, but this does not reset the IO buffer). The following diagrams show the timing of the SPI™ interface.

33.2.5 Write Only Mode

In “write only” mode (SPI_FIFO_MODE = 10) only the TX-FIFO is used. Received data will be copied to the SPI_RX_TX_REG, but if a new SPI transfer is finished before the old data is read from the memory, this register will be overwritten.

SPI_INT acts as a tx_request signal, indicating that there is still place in the FIFO. It is 0 when the FIFO is full or 1 when it's not full. This is shown in the SPI_CTRL_REG[SPI_TXH], which is 1 if the TX-FIFO is full. Writing to the FIFO if this bit is still 1, will result in transmission of undefined data. If all data has been transferred, SPI_CTRL_REG1 [SPI_BUSY] will become 0.

33.2.6 Read Only Mode

In “read-only” mode (SPI_FIFO_MODE = 01), only the RX-FIFO is used. Transfers will start immediately when the SPI is turned on in this mode. In transmit direction, the SPI_DO pin will transmit the IO buffer contents being the actual value of the SPI_TX_REGx (all 0's after reset). This means that no dummy writes are needed for read only transfers.

In Slave mode, transfers only take place if the external master initiates them, but in master mode this means that transfers will continue until the RX-FIFO is full. If this happens, SPI_CTRL_REG1[SPI_BUSY] will become 0. If

exactly N words need to be read from SPI device, first read (N - fifosize+1) words. Then it waits until the SPI_BUSY becomes 0, set SPI_FIFO_MODE to 00 and finally reads the remaining (fifosize +1) words. Here, fifosize is 4/2/1 words for 8/16/32 bits mode respectively.

If this is not done, more data will be read from the SPI device until the FIFO is completely filled, or the SPI is turned off.

33.2.7 Bidirectional Transfers with FIFO

If SPI_FIFO_MODE is 00, both registers are used as a FIFO. SPI_TXH indicates that TX-FIFO is full, SPI_INT indicates that there is data in the RX-FIFO.

33.2.8 TXreq Mode

In case of the no FIFO mode, a Tx_buffer available event is generated when Tx buffer is empty. This event triggers the DMA with a dma_tx_request when SPI_DMA_TXREQ_MODE is set. Additionally, the same event generates an interrupt to the CPU when SPI_TX_FIFO_NOFULL_MASK is set.

33.2.9 DMA Operation Requirements

If the DMA operation is needed when the TX-FIFO is disabled (SPI_CTRL_REG[SPI_FIFO_MODE] = 0x3) and SPI_CTRL_REG[SPI_DMA_TXREQ_MODE] = 0, the CPU needs to write one byte to the SPI_RX_TX_REG register before the DMA takes control of the data transfer.

Additionally, the edge-sensitive requests have to be enabled in the Tx DMA channel (DMAx_CTRL_REG[REQ_SENSE] = 0x1). Otherwise, the DMA priorities should be programmed in favor of the Rx DMA channel, when both channels (Rx/Tx) are used.

If SPI_CTRL_REG[SPI_PRIORITY] is set, edge-sensitive DMA requests cannot be used, since the SPI Rx/Tx DMA requests do not de-assert until the RX-FIFO is empty and the TX-FIFO is full. So, in this mode (and SPI_CTRL_REG[SPI_FIFO_MODE] = 0x3), the only way to use the DMA to serve SPI in both directions, is by programming the DMA channel priorities in favor of the Rx DMA channel.

It should be noted that Tx DMA requests are not supported when:

1. SPI_CTRL_REG[SPI_FIFO_MODE]=0x0 or 0x2 (both FIFOs enabled or Tx FIFO only) and SPI_CTRL_REG[SPI_WORD]=0x2 (32-bit SPI data enabled). The Tx DMA requests can only be supported for 8-bit and 16-bit SPI data.
2. SPI_CTRL_REG[SPI_FIFO_MODE]=0x1 (Rx FIFO only mode).

33.2.10 The 9-Bit Mode

The 9-bit mode can be used to support 9-bit displays. This is selected with SPI_CTRL_REG[SPI_WORD] set to '11'. The value of the ninth bit is set in the SPI_CTRL_REG1[SPI_9BIT_VAL] and is used to determine if the next 8 bits form a command word or data word. Because the 9th bit is not part of the data, the FIFOs are still used in the 8-bit mode. The 9th bit is received but not saved because it is shifted out of the 8-bit shift register upon reception.

33.2.11 Timing Diagrams

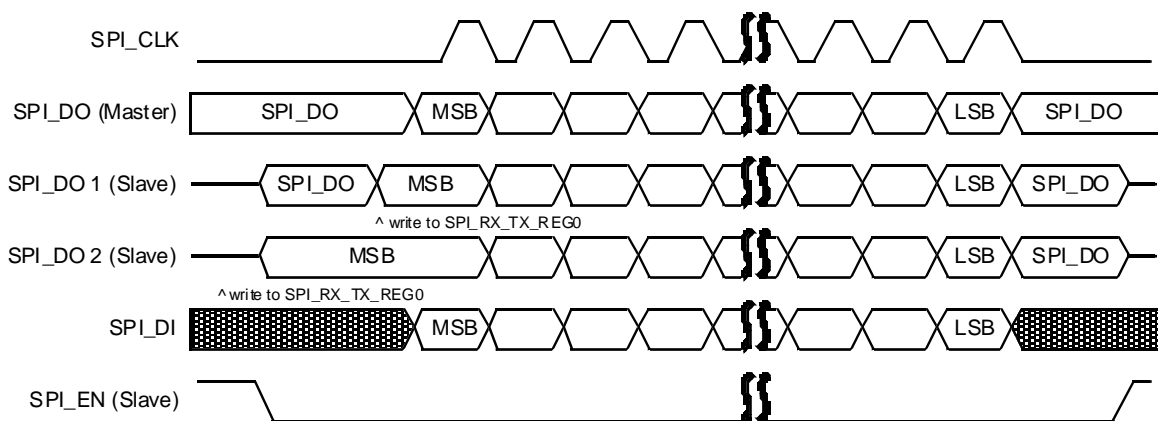

Figure 87. SPI Master/Slave mode 0: SPI_POL=0 and SPI_PHA=0

Note 1 If 9-bit SPI mode, the MSB bit in transmit direction is determined by bit SPI_CTRL_REG[SPI_9BIT_VAL]. In receive direction, the MSB is received but not stored.

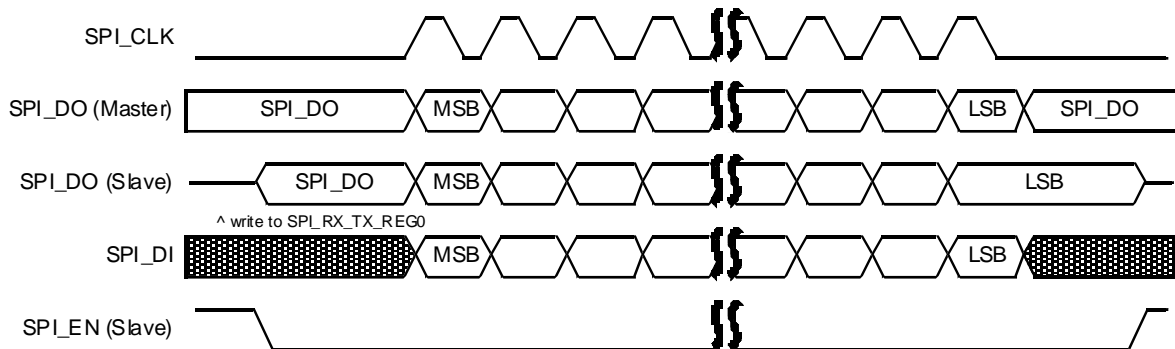

Figure 88. SPI Master/Slave mode 1: SPI_POL=0 and SPI_PHA=1

For the MSB bit refer to [Note 1](#).

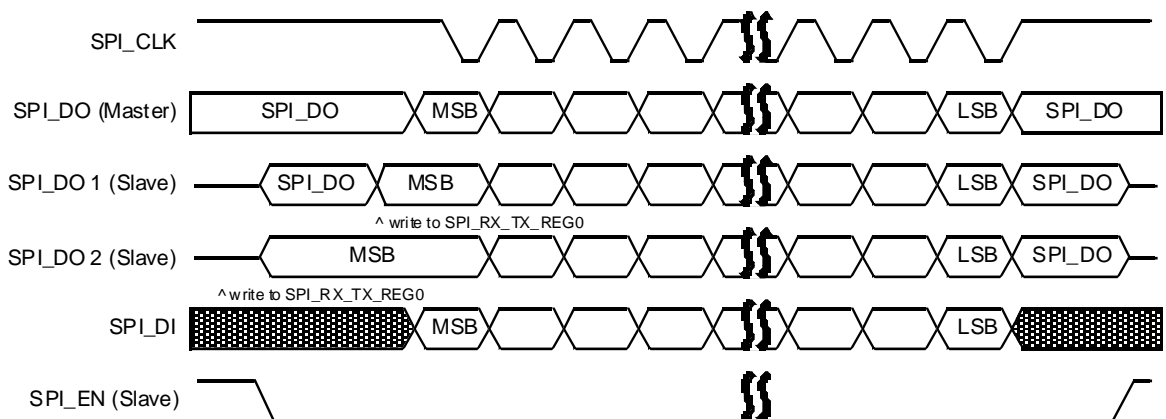

Figure 89. SPI Master/Slave mode 2: SPI_POL=1 and SPI_PHA=0

For the MSB bit refer to [Note 1](#).

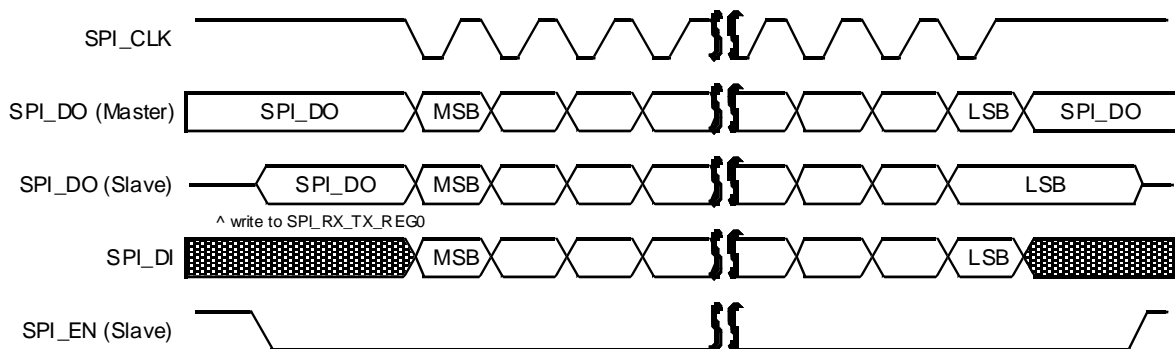

Figure 90. SPI Master/slave mode 3: SPI_POL=1 and SPI_PHA=1

For the MSB bit see [Note 1](#).

33.2.12 SPI Timing

The timing of the SPI interface when the SPI controller is in slave mode is presented in [Figure 91](#).

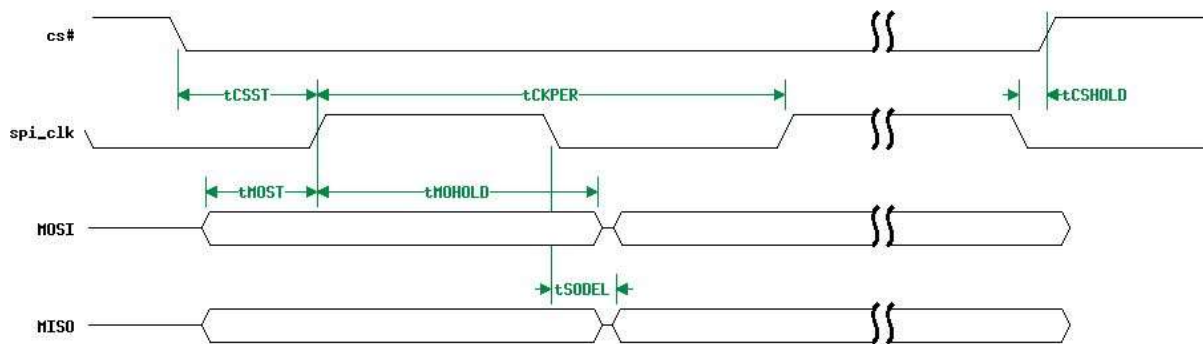

Figure 91. SPI Slave mode timing (CPOL = 0, CPHA = 0)

Table 143: SPI timing parameters

Parameter	Description	Typ	Unit
tCKPER_96M	Min spi_clk clock period when sys_clk = 96 MHz	41.6	ns
tCKPER_32M	Min spi_clk clock period when sys_clk = 32 MHz	125	ns
tCSST	CS active time before the first edge of spi_clk	$2 * \text{sys_clk} + 10$	ns
tCSHOLD	CS non-active time after the last edge of spi_clk	0	ns
tMOST	Master input data latching setup time	1	ns
tMOHOLD	Master input data hold time	1	ns
tSODEL	Slave output data delay	9	ns

33.3 Programming

There is a simple sequence of steps that can be followed to configure and use the SPI controllers:

1. Set up the GPIOs to be used for the SPI interface ($Px_yy_MODE_REG[PID] = 13$ to 20).
2. Set SPI mode as master by clearing the $SPIx_CTRL_REG[SPI_SMN]$ bit or slave by setting it. In SPI slave mode, enable the SPI_EN pin ($SPIx_CTRL_REG[SPI_EN_CTRL]$).
3. Set up SPI clock frequency ($SPIx_CTRL_REG[SPI_CLK]$).
4. Select SPI clock phase ($SPIx_CTRL_REG[SPI_PHA]$).
5. Select SPI clock polarity ($SPIx_CTRL_REG[SPI_POL]$).
6. Select SPI word size ($SPIx_CTRL_REG[SPI_WORD]$).
7. Set up SPI FIFO mode if needed ($SPIx_CTRL_REG[SPI_FIFO_MODE]$).
8. Enable SPI by setting the $SPIx_CTRL_REG[SPI_ON]$ bit.
9. Assert the CS pin.
10. Write the data to $SPIx_RX_TX_REG$.
11. Poll the $SPIx_CTRL_REG[SPI_INT_BIT]$ until it becomes 1.
12. Read the data from $SPIx_RX_TX_REG$.
13. Clear SPI_INT_BIT by writing the $SPIx_CLEAR_INT_REG$ register.
14. De-assert the CS pin.

To reset/update the SPI controller configuration, a dedicated sequence should be followed:

1. Disable SPI controller by clearing the $SPIx_CTRL_REG[SPI_ON]$ bit.
2. Reset the SPI controller by setting the $SPIx_CTRL_REG[SPI_RST]$ bit.
3. Update the SPI configuration
4. Enable the SPI controller ($SPIx_CTRL_REG[SPI_ON] = 1$).
5. Release SPI reset ($SPIx_CTRL_REG[SPI_RST] = 0$).

6. Set up SPI_INT_BIT (SPIx_CTRL_REG[SPI_MINT]).

34. Real Time Clock

Device:	DA14691	DA14695	DA14697	DA14699
Feature Availability:	✓	✓	✓	✓

34.1 Introduction

The DA1469x is equipped with a Real Time Clock (RTC) which provides complete clock and calendar information with automatic time units' adjustment and easy configuration.

Features

- Complete time of day clock: 12/24 hour, hours, minutes, seconds, and hundredths
- Calendar function: day of week, date of month, month, year, century, leap year compensation, and year 2000 compliant
- Alarm function: month, date, hour, minute, second, and hundredths resolution
- Event interrupt on any calendar or time unit
- Available during sleep
- Granularity of 10 ms.

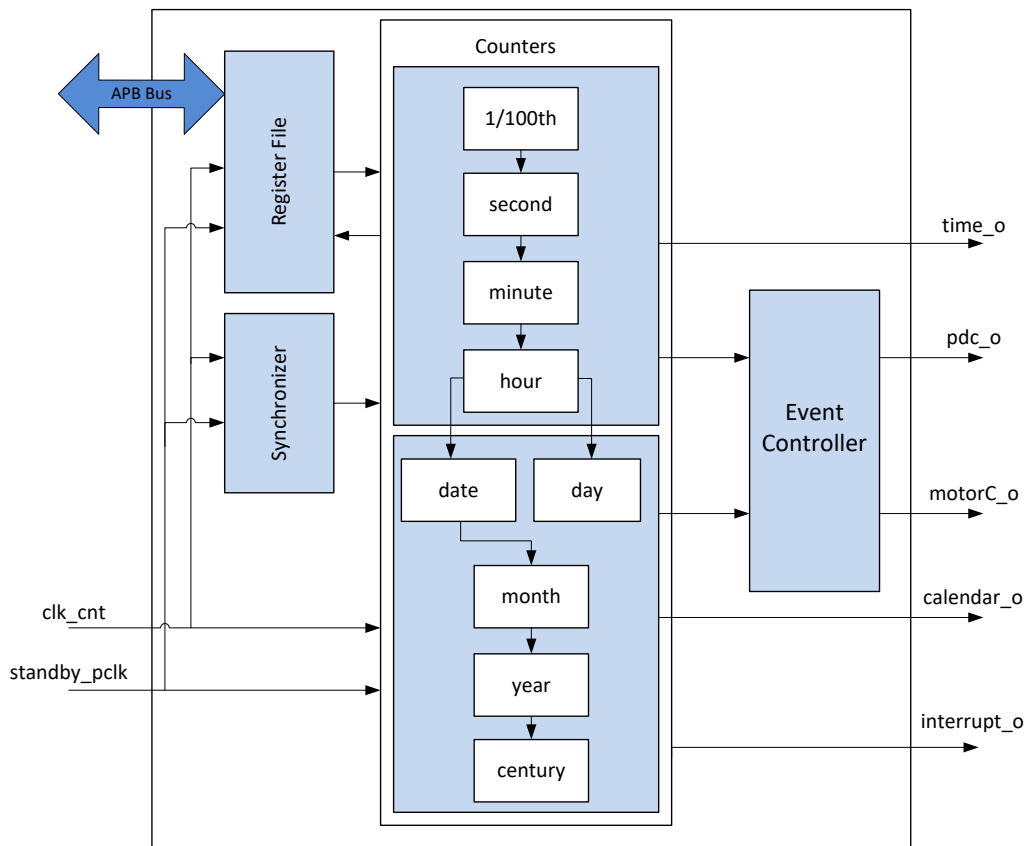

Figure 92. Real Time Clock block diagram

34.2 Architecture

The architecture of the Real Time Clock is depicted in [Figure 92](#).

The RTC supports a year range from 1900 to 2999 as well as full month, date, minute, second, and hundredth of second ranges. It also supports hour ranges of 0 to 23 (24-hour format), or 1 to 12 with a.m./p.m. flag (12-hour format).

Alarms can be generated in two ways: as a one-time alarm, or as a recurring alarm. In addition to alarms, the RTC can detect when a particular event occurs. Each field of the calendar and time counter can generate an

event when it rolls over. For example, an event can be generated every new month, new week, new day, new half day (12-hour mode), new minute, or new second. Both alarms and events can generate an interrupt. All the interrupts can be set, enabled, disabled, or masked at any time.

The RTC block has been enhanced with the RTC_EVENT_CONTROLLER.

This controller is triggered every 10 ms or when there is a roll-over. It comprises a 12-bit counter which counts down starting from a configurable value (programmed in RTC_MOTOR_EVENT_PERIOD). This operation can be enabled/disabled by RTC_MOTOR_EVENT_EN.

Every time the counter reaches 0, an event signal is asserted, generating a pulse to the Motor Controller. This signal is used as a trigger for the motor controller operation.

The RTC_EVENT_CONTROLLER also comprises a 13-bit counter which counts down starting from a configurable value (programmed in RTC_PDC_EVENT_PERIOD). This operation can be enabled/disabled by RTC_PDC_EVENT_EN.

Every time this counter reaches 0, a signal towards the PDC is asserted. The same signal is also driven to the Cortex-M33 RTC_EVENT interrupt line. The signal is automatically de-asserted after the RTC_PDC_EVENT_CLEAR_REG is read.

Both counters are accessible by the Cortex-M33 CPU (RTC_PDC_EVENT_CNT_REG and RTC_MOTOR_EVENT_CNT_REG).

34.3 Programming

There is a simple sequence of steps that needs to be followed to configure the RTC:

1. Configure the 100 Hz RTC granularity if needed:
 - a. Based on the selected LP clock (for example, 32768 Hz), set the CLK_RTCDIV_REG[RTC_DIV_INT] = 327 (= 0x147).
This value should be equal to the integer divisor part of the formula
 $F_{LP_CLK}/100 = 327.680$.
 - b. Based on the selected LP clock (for example, 32768 Hz), set the CLK_RTCDIV_REG[RTC_DIV_FRAC] = 680 (= 0x2A8).
This value should be equal to the fractional divisor part of the formula
 $F_{LP_CLK}/100 = 327.680$.
 - c. To achieve better accuracy of the divisor, configure the denominator for the fractional division accordingly (CLK_RTCDIV_REG[RTC_DIV_DENOM]).
 - d. Enable the 100 Hz RTC granularity by setting the CLK_RTCDIV_REG [RTC_DIV_ENABLE] bit.
2. Enable the time functionality by clearing the RTC_CONTROL_REG[RTC_TIME_DISABLE].
3. Enable the calendar functionality by clearing the RTC_CONTROL_REG[RTC_CAL_DISABLE].
4. Choose between 12 or 24 hours based mode (RTC_HOUR_MODE_REG[RTC_HMS]).
5. Configure the time (RTC_TIME_REG).
6. Configure the date (RTC_CALENDAR_REG).
7. Set up a time alarm if needed (RTC_ALARM_ENABLE_REG).
8. Set up a calendar alarm if needed (RTC_CALENDAR_ALARM_REG).
9. Enable the configured alarms (RTC_ALARM_ENABLE_REG[RTC_ALARM_xxxx_EN]).
10. Configure the interrupt generation when an alarm happens (RTC_INTERRUPT_ENABLE_REG). Disable the interrupt generation with RTC_INTERRUPT_DISABLE_REG.
11. Configure the event flag generation when an alarm happens (RTC_EVENT_FLAGS_REG).
12. Choose if software reset resets the RTC (RTC_KEEP_RTC_REG[RTC_KEEP]).
13. Set up the Event Controller, if needed:
 - a. If trigger to PDC is enable:
 - i. Set up the event period (RTC_PDC_EVENT_PERIOD_REG[RTC_PDC_EVENT_PERIOD]).
 - ii. Enable the PDC to trigger (RTC_EVENT_CTRL_REG[RTC_PDC_EVENT_EN]).
 - b. If trigger to Motor Controller is enable:

- i. Set up the event period (RTC_MOTOR_EVENT_PERIOD_REG[RTC_MOTOR_EVENT_PERIOD]).
- ii. Enable the Motor Controller to trigger (RTC_EVENT_CTRL_REG[RTC_MOTOR_EVENT_EN]).

35. General Purpose Timers

Device:	DA14691	DA14695	DA14697	DA14699
Feature Availability:	✓	✓	✓	✓

35.1 Introduction

The Timers block contains four identical 24-bit wide timers (namely, Timer, Timer2, Timer3, and Timer4) that are software controlled, programmable, and can be used for various tasks. Timer and Timer2 are in the timers' power domain (PD_TMR), while Timer3 and Timer4 are in the system power domain (PD_SYS).

Features

- Four 24-bit general purpose timers
- Pulse Width Modulated signal (PWM)
- Two channels for capture input triggered by GPIOs (Timer has four channels)
- One shot pulse with programmable pulse width (only valid for Timer and Timer2)
- 5-bit clock pre-scaler
- Selectable system or sleep clock source
- Up/down counting capability with free running mode
- Active while system is in sleep mode
- Dedicated interrupt line per timer (Timer supports one extra interrupt line for complex capture events)

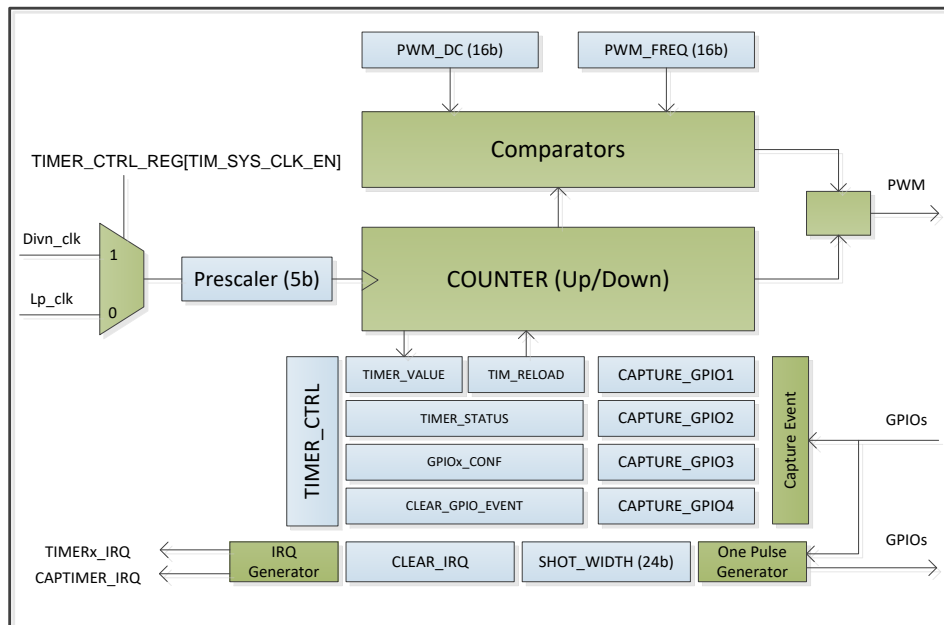

Figure 93. General Purpose Timer's block diagram

35.2 Architecture

There are four instances of the same Timer block (Timer, Timer2, Timer3, and Timer4) in the system with minor modifications between the instances. The Timer's block diagram is shown in [Figure 93](#). The only differences between the actual instances are the following:

- Timer and Timer2 are part of the PD_TMR domain, while Timer3 and Timer 4 are part of the PD_SYS power domain.
- Timer3 and Timer4 do not support the one-shot feature.
- Timer supports four channels (GPIOs) for capturing events, while the rest supports two channels. Timer also has a separate interrupt line dedicated to these channel activities.

- Timer and Timer2 can drive specific GPIOs, even when the system is in sleep mode.

In general, each block has a configurable free-running up/down counter that operates either on the system clock (sys_clk) or the low power clock (lp_clk) with a pre-scaler of 5 bits. This results in a minimum frequency of one kHz and a maximum of 32 MHz.

Each block has a PWM generator which does not affect the actual timer running. The PWM generator can define the frequency and the duty cycle of the generated PWM signal by further dividing the clock by maximum ($2^{16}+1$), resulting in a minimum speed of 0.015 kHz. A 16-bit PWM duty cycle enables 65535 steps for defining the pulse width. Note that for the minimum PWM frequency only 50 % duty cycle is possible. Also, note that the values in the respective registers for the duty cycle and the frequency represent clock counts. Duty cycle value needs to be always less than frequency to the PWM generator to work correctly.

Capturing an edge of a GPIO is another feature of the Timer block. As a matter of fact, any edge on any (configurable) GPIO can be sensed to trigger a Timer's snapshot stored into a separate register. Another (or the same) GPIO can be configured for capturing a second edge, hence storing a second snapshot into a second register. The difference of these two registers indicates the time distance of the two triggering events, hence it can be used for measuring the frequency of a signal or the timing interval between two interrupts coming from external devices.

One-shot is also supported. Upon a trigger configured as an input on a GPIO, another GPIO serves as an output, delivering a pulse of configurable width. This is basically a PWM reply in hardware.

There are specific GPIOs that can be configured to be input events to the Timer blocks. The actual configuration is presented in [Table 144](#).

Table 144: Timer's Input GPIOs

Timer Input	Value	GPIO
TIMER_GPIOx_CONF_REG	0-32	0: Disabled, 1-32: P0_0 to P0_31
TIMER2_GPIOx_CONF_REG	0-32	0: Disabled, 1-23: P1_0 to P1_22, 24-32: P0_23 to P0_31
TIMER3_GPIOx_CONF_REG	0-32	0: Disabled, 1-32: P0_0 to P0_31
TIMER4_GPIOx_CONF_REG	0-32	0: Disabled, 1-23: P1_0 to P1_22, 24-32: P0_23 to P0_31

Note that Timer and Timer2 are able to output PWM signals available during sleep (CLK_TMR_REG[TMR_PWM/2_AON_MODE]) on P1_01 and P1_06 accordingly.

35.3 Programming

There is a simple sequence of steps that needs to be followed to program the GP Timers:

1. Disable the Timer by clearing the `TIMERx_CTRL_REG[TIM_EN]` bit and the `TIMERx_CTRL_REG[TIM_CLK_EN]` bit.
2. Select Timer's clock (`TIMER_CTRL_REG[TIM_SYS_CLK_EN]`) and pre-scaler (`TIMER_PRESCALER_REG`).
3. Enable Timer's clock (`TIMERx_CTRL_REG[TIM_CLK_EN]`).
4. Select Timer's mode (`TIMER_CTRL_REG[TIM_ONESHOT_MODE_EN]`).
 - a. One shot mode (TIMER/TIMER2):
 - i. Set delay phase (`TIMER/2_RELOAD_REG`).
 - ii. Set shot phase duration (`TIMER/2_SHOTWIDTH_REG`).
 - iii. Select one shot/primary capture event input (`TIMER/2_GPIO1_CONF_REG`) and trigger polarity (`TIMER/2_CTRL_REG[TIM_IN1_EVENT_FALL_EN]`).
 - iv. Select the secondary capture event input (`TIMER/2_GPIO2_CONF_REG`) and trigger polarity (`TIMER/2_CTRL_REG[TIM_IN2_EVENT_FALL_EN]`).
 - b. Counter mode (all Timers):
 - i. Set timer's up/down direction (`TIMER_CTRL_REG[TIM_COUNT_DOWN_EN]`).
 - ii. Set timer's reload or max value (`TIMERx_RELOAD_REG`).
 - iii. Enable free run mode if timer counts upwards by setting the `TIMERx_CTRL_REG[TIM_FREE_RUN_MODE_EN]` bit.

- iv. Set up capture events input (TIMERx_GPIOy_CONF_REG) and trigger polarity (TIMERx_CTRL_REG[TIM_INx_EVENT_FALL_EN]). Note that TIMER supports up to four capture events inputs.
5. Configure PWM:
 - a. Set up frequency (TIMERx_PWM_FREQ_REG).
 - b. Configure duty cycle (TIMERx_PWM_DC_REG).
6. Select if event on the selected input GPIOs creates a CAPTIM interrupt (TIMERx_CTRL_REG[TIM_CAP_GPIOy_IRQ_EN]).
7. Set up GPIO as Timer output (Px_yy_MODE_REG[PID] = 3, Px_yy_MODE_REG[PID] = 49 to 54, see P0_00_MODE_REG description).
Note that TIMER and TIMER2 PWM outputs can be activated at specific pins (P1_01 and P1_06) during sleep by setting the CLK_TMR_REG[TMRx_PWM_AON_MODE] bits.
8. Enable Timer interrupt by setting the TIMERx_CTRL_REG[TIM_IRQ_EN] bit.
9. Enable Timer by setting the TIMERx_CTRL_REG[TIM_EN] bit.

36. Watchdog Timers

Device:	DA14691	DA14695	DA14697	DA14699
Feature Availability:	✓	✓	✓	✓

36.1 Introduction

The DA1469x contains two watchdog timers:

- The System watchdog that is in the always ON power domain
- The CMAC watchdog that is in the radio power domain.

They protect the system from getting stuck because of software problems both in the application processor (Cortex-M33) and in the CMAC area (Cortex-M0+). They are clocked by internally generated clocks, RC32K or RCX, and the low power clock, XTAL32K or RCX, respectively.

CMAC watchdog is accessible by the Cortex-M33 if the radio power domain is powered up.

Features

- System Watchdog:
 - A 13 bits down counter running on either RC32K or RCX further divides these clocks by 320 and can operate for 84 seconds or three minutes, depending on the clock.
 - Internal programmable clock sources are RC32K or RCX, of which RC32K is the default. If RCX is used as a sleep clock, RC32K might be turned off.
 - Generates:
 - NMI to Cortex-M33 if counter reaches 0.
 - Hardware reset if counter reaches -16.
 - Protected by a lock bit to avoid freeze by mistake.
 - Automatically frozen when Cortex-M33 is in debug mode.
- CMAC Watchdog:
 - A 13 bits down counter running on the lp_clk further divides this clock by 32.
 - Generates:
 - Early notification interrupt to Cortex-M0+ if counter reaches 16.
 - CMAC2SYS_IRQ to Cortex-M33 if counter reaches 0.
 - Hardware reset if counter reaches -16.
 - Protected by a lock bit to avoid freeze by mistake.
 - Automatically frozen when Cortex-M0+ is in debug mode.

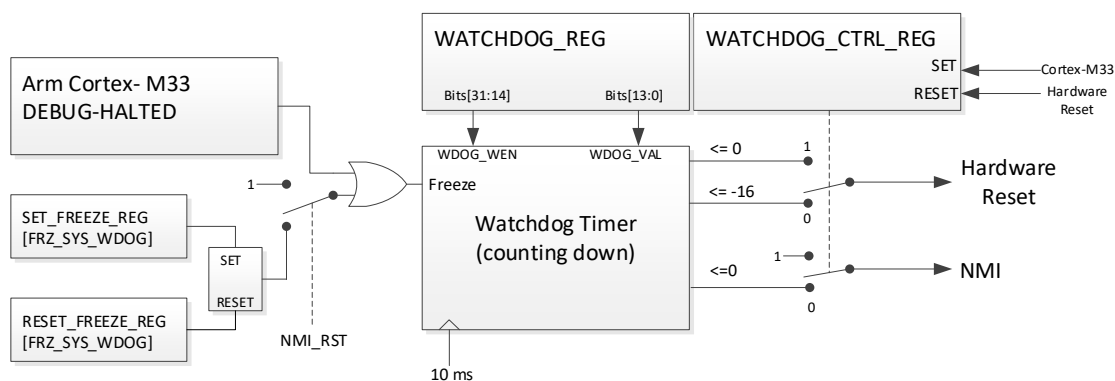

Figure 94. System watchdog block diagram

36.2 Architecture

The System Watchdog is supplied by the always on domain (PD_AON) and is automatically enabled as soon as the system powers up. It is decremented by one every 10 ms, assuming the default source clock is the RC32K.

The timer value can be accessed through the WATCHDOG_REG which is set to max value at reset. This results in a maximum watchdog time-out of 87 seconds. If the RCX is used as a source clock, the time-out time is even longer, depending on the RCX frequency.

During write access WATCHDOG_REG bits [31-14] must be 0. This provides extra filtering for a software run-away writing all ones to the WATCHDOG_REG. If the watchdog reaches 0, the counter value will get a negative value setting bit 13. The counter sequence is 1, 0, 1FFF16 (-1), 1FFE16(-2),...,1FF016 (-16).

If WATCHDOG_CTRL_REG[NMI_RST] = 0, the watchdog timer will generate an NMI to the Cortex-M33 when the watchdog timer reaches 0 and a hardware reset when the counter becomes less or equal to -16. The NMI handler must write any value > -16 to the WATCHDOG_REG to prevent the generation of a WDOG reset within $16 \times 10 = 160$ ms.

If WATCHDOG_CTRL_REG[NMI_RST] = 1, the watchdog timer generates a WDOG reset if the timer becomes less or equal than 0.

The system watchdog can be frozen by Cortex-M33. It is always frozen automatically when the debugger is attached, and the Cortex-M33 CPU is halted during debugging. However, even if the watchdog is frozen by Cortex-M33, when Cortex-M33 gets into any sleep mode (PD_SYS is turned off), the system watchdog will be automatically resumed to operate during sleep.

The CMAC Watchdog is basically the same circuit with the following amendments:

- It resides in the radio power domain (PD_RAD). It will be active as soon as the radio power domain is enabled.
- Its clock source is the low power clock (lp_clk). It is further divided by 32 to provide a clock period of 1 ms (assuming lp_clk is XTAL32K). Hence, this watchdog can reach maximum 16 ms before reaching 0.
- It has one extra notification compared to the system watchdog:
 - When 16 is reached, an interrupt will be issued to the Cortex-M0+ (CMAC).
 - When 0 is reached, an interrupt will be issued to the Cortex-M33.
 - When -16 is reached, a hardware reset will be triggered.

This watchdog is also automatically halted when the debugger is attached and the Cortex-M0+ is halted during debugging.

36.3 Programming

36.3.1 System Watchdog

There is a simple sequence of steps that needs to be followed to program the System Watchdog Timer:

1. Switch to RCX clock as source if needed (CLK_RCX_REG[RCX_ENABLE]).
2. Freeze watchdog by setting the SET_FREEZE_REG[FRZ_SYS_WDOG] bit (optionally).
3. Select NMI and reset events (WATCHDOG_CTRL_REG[NMI_RST]).
4. Wait until WATCHDOG_CTRL_REG[WRITE_BUSY] = 0.
5. Enable writing of the watchdog timer (WATCHDOG_REG[WDOG_WEN] = 0).
6. Write watchdog timer reload value (WATCHDOG_REG[WDOG_VAL], see register description).
7. Resume watchdog (RESET_FREEZE_REG[FRZ_SYS_WDOG] = 1), if frozen.

36.3.2 CMAC Watchdog

There is no specific sequence of steps for the CMAC Watchdog since it gets automatically enabled. Some general points are referred below:

- The CMAC watchdog is automatically enabled when the radio power domain is activated.
- CMAC takes care of reloading the watchdog timer frequently. M33 intervention is not necessary.
- M33 can freeze/unfreeze the CMAC watchdog (SET_FREEZE_REG[FRZ_SYS_WDOG]) and reload the watchdog timer (CM_WDOG_REG[CM_WDOG_CNT]), if needed.
- CMAC watchdog automatically freezes when Cortex-M0+ is halted via the SWD.
- When the system power domain is powered down, it's not possible to freeze CMAC watchdog via software.

37. USB Controller

Device:	DA14691	DA14695	DA14697	DA14699
Feature Availability:	✓	✓	✓	✓

37.1 Introduction

The USB interface is an integrated USB Node controller compatible with the full speed (FS) and low speed (LS) *USB specification, version 1.1 (V1.1)*.

It integrates a Serial Interface Engine (SIE) and USB endpoint (EP) FIFOs. Seven endpoint pipes are supported: one for the mandatory control endpoint and the other six for interrupt endpoints. Each endpoint pipe has a dedicated FIFO, 8 bytes for the control endpoint and 64 bytes for the other endpoints.

The USB transceiver module is accessed through USB_Dp and USB_Dm pins.

Features

- Full Speed/Low Speed USB node.
- Interfaces to USB V1.1 transceiver with programmable rise and fall times and integrated D+/D- pull-up resistors.
- Serial Interface Engine (SIE) consisting of a Media Access Controller (MAC), *USB Specification 1.0* and *1.1* compliant.
- USB Function Controller with seven FIFO-based Endpoints:
 - One bidirectional Control Endpoint 0 (8 B).
 - Three Transmit Endpoints (64 B each).
 - Three Receive Endpoints (64 B each).
- Automatic Data PID toggling/checking and NAK packet recovery (maximum 256x32 bytes of data = 8 kB).

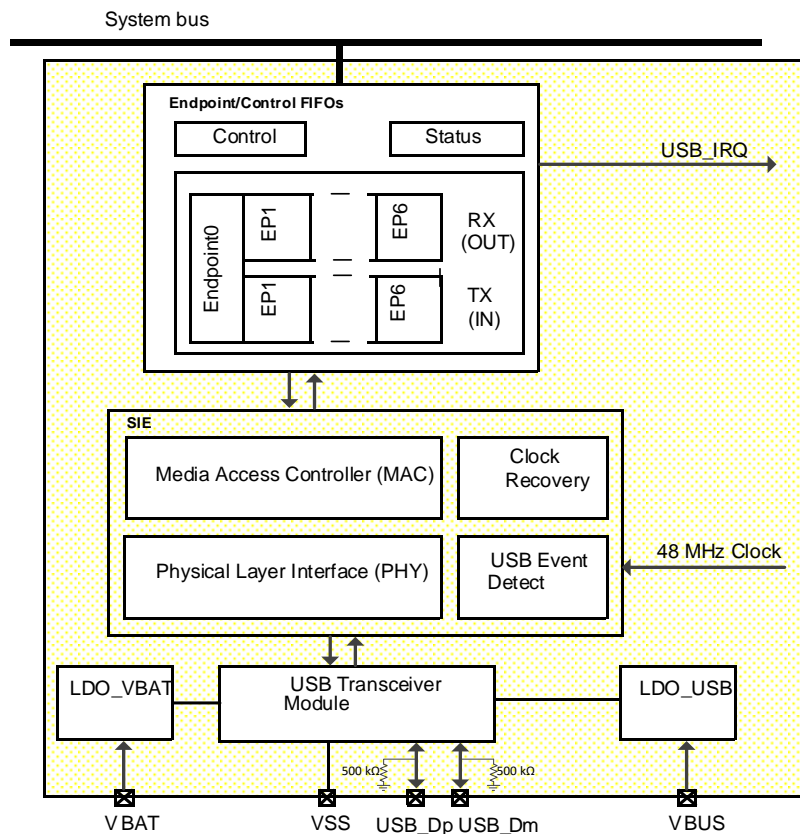

Figure 95. USB Node block diagram

37.2 Architecture

37.2.1 Serial Interface Engine

The SIE is comprised of physical (PHY) and Media Access Controller (MAC) modules. The PHY module includes the digital-clock recovery circuit, a digital glitch filter, End of Packet (EOP) detection circuitry, and bit stuffing and unstuffing logic. The MAC module includes packet formatting, CRC generation and checking, and endpoint address detection. It provides the necessary control to give the NAK, ACK, and STALL responses determined by the Endpoint Pipe Controller (EPC) for the specified endpoint pipe. The SIE is also responsible for detecting and reporting USB-specific events, such as NodeReset, NodeSuspend, and NodeResume. The module output signals to the transceiver are well matched (under 1 ns) to minimize skew on the USB signals.

The USB specifications use bit stuffing and unstuffing as the method to ensure adequate electrical transitions on the line to enable clock recovery at the receiving end. The bit stuffing block ensures that whenever a string of consecutive 1's is encountered, a 0 is inserted after every sixth 1 in the data stream. The bit unstuffing logic reverses this process.

The clock recovery block uses the incoming NRZI data to extract a data clock (12 MHz for FS, 1.5 MHz for LS) from a 48 MHz (FS)/6 MHz (LS) input clock. The extracted data clock is used in the data recovery circuit. The output of this block is binary data which is decoded from the NRZI stream and can be appropriately sampled using the extracted 12(1.5) MHz clock. The jitter performance and timing characteristics meet the requirements in *Chapter 7 of the USB Specification*.

37.2.2 Endpoint Pipe Controller (EPC)

The EPC provides the interface for USB function endpoints. An endpoint is the ultimate source or sink of data. An endpoint pipe facilitates the movement of data between USB and memory and completes the path between the USB host and the function endpoint. According to the *USB specification*, up to 31 such endpoints are supported at any given time. USB allows a total of 16 unidirectional endpoints for receive and 16 for transmit. As the control endpoint 0 is always bidirectional, the total number is 31. The FS/LS USB node supports a maximum of seven endpoint pipes with the same function address. See [Figure 96](#) for a schematic diagram of the EPC operation.

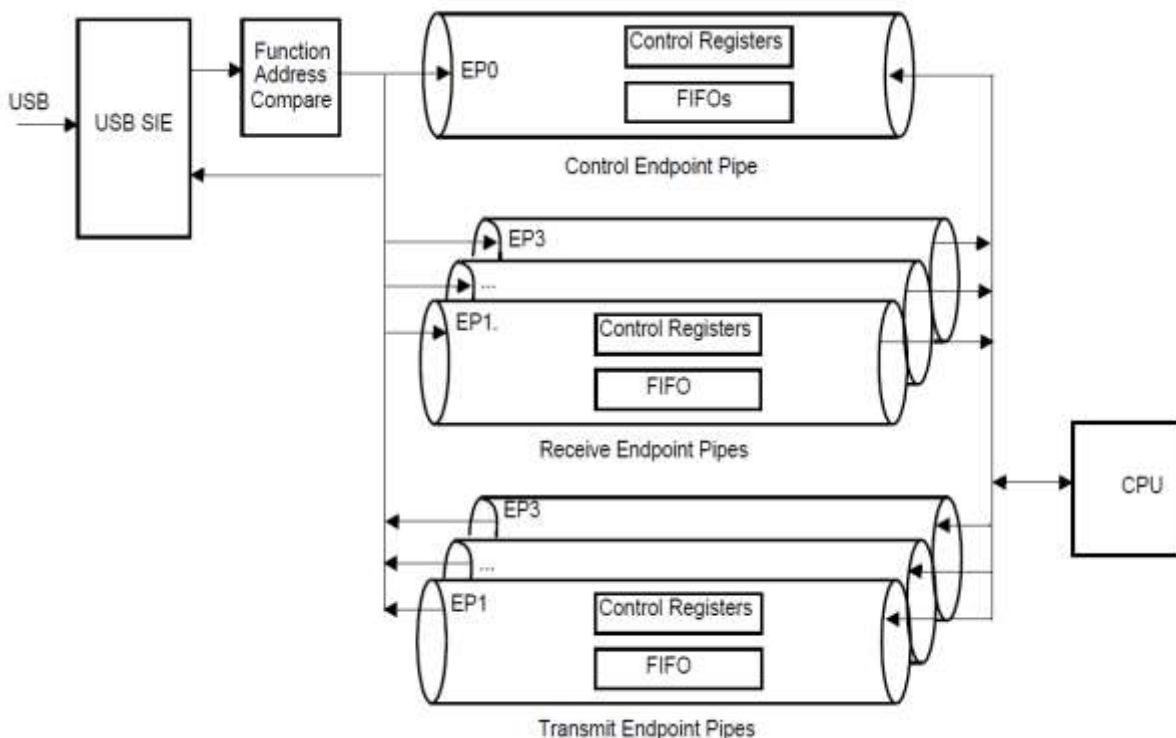

Figure 96. Endpoint operation

A USB function is a USB device that can transmit and receive information on the bus. A function may have one or more configurations, each of which defines the interfaces that make up the device. Each interface, in turn, is composed of one or more endpoints.

Each endpoint is an addressable entity on USB and is required to respond to IN and OUT tokens from the USB host (typically a PC). IN tokens indicate that the host has requested to receive information from an endpoint, and OUT tokens indicate that it is about to send information to an endpoint.

On detection of an IN token addressed to an endpoint, the endpoint pipe should respond with a data packet. If the endpoint pipe is currently stalled, a STALL handshake packet is sent under software control. If the endpoint pipe is enabled but no data is present, a Negative Acknowledgment (NAK) handshake packet is sent automatically. If the endpoint pipe is isochronous and enabled but no data is present, a bit stuff error followed by an “end of packet” is sent on the bus.

Similarly, on detection of an OUT token addressed to an endpoint, the endpoint pipe should receive a data packet sent by the host and load it into the appropriate FIFO. If the endpoint pipe is stalled, a STALL handshake packet is sent. If the endpoint pipe is enabled but no buffer is present for data storage, a NAK handshake packet is sent.

A disabled endpoint does not respond to IN, OUT, or SETUP tokens.

The EPC maintains separate status and control information for each endpoint pipe.

For IN tokens, the EPC transfers data from the associated FIFO to the host. For OUT tokens, the EPC transfers data in the opposite direction.

37.2.3 Functional States

37.2.3.1 Line Condition Detection

At any given time, the USB node is in one of the following states:

- **NodeOperational:** this is the normal operating state of the node. In this state, the node is configured for operation on the USB.
- **NodeSuspend:** Device operation suspended due to USB inactivity.
 - A USB node is expected to enter NodeSuspend state when 3 ms have elapsed and no bus activities have been detected.
 - The USB node looks for this event and signals it by setting the SD3 bit in the USB_ALTEV register, which causes an USB_INT, if enabled, to be generated. The firmware should respond by putting the USB node in NodeSuspend state.
- **NodeResume:** Device wake-up from the suspended state.
 - In NodeResume state, a constant "K" is signaled on the USB and should last at least 1 ms and no more than 15 ms. After that, the USB host should continue sending the NodeResume signal for at least another 20 ms, and then completes the NodeResume operation by issuing the End Of Packet (EOP) sequence
- **NodeReset:** Device reset.
 - When detecting a NodeResume or NodeReset signal while in NodeSuspend state, the USB node can signal it to the CPU by generating an interrupt.

The NodeSuspend, NodeResume, or NodeReset line condition causes a transition from one operating state to another. These conditions are detected by specialized hardware and reported via the Alternate Event (ALTEV) register. If interrupts are enabled, an interrupt is generated upon the occurrence of any of the specified conditions.

Refer to Section [37.2.11](#) on how to obtain the lowest power consumption in the NodeSuspend state.

The USB node can resume the normal operation in two ways:

- **Host initiated.** When a resume signal followed by LS EOP on the USB is detected, an ALTEV[RESUME] interrupt is generated. The firmware responds by setting the NodeOperational in the USB_NFSR_REG (see also Section [37.2.11](#)).
- **Device initiated.** When a local event is detected, for example, a GPIO key is pressed, a KEYB_INT is generated. The firmware releases the USB node from the NodeSuspend state by initiating a NodeResume signal on the USB using the NFSR register. The node firmware must ensure at least 5 ms of Idle on the USB by checking the SD5 in the USB_ALTEV before going to the NodeResume state.

To successfully detect the EOP, the firmware must respond by setting NodeOperational in the USB_NFRS_REG. Once an EOP is detected, the USB_ALTEV_REG[EOP] is set. If no EOP is received from the host within 100 ms, the software must re-initiate NodeResume.

USB specifications require that a device must be ready to respond to USB tokens within 10 ms after wake-up or reset.

37.2.4 Functional State Diagram

[Figure 97](#) shows the device states and transitions as well as the conditions that trigger each transition. All FS/LS USB node state transitions are initiated by the firmware.

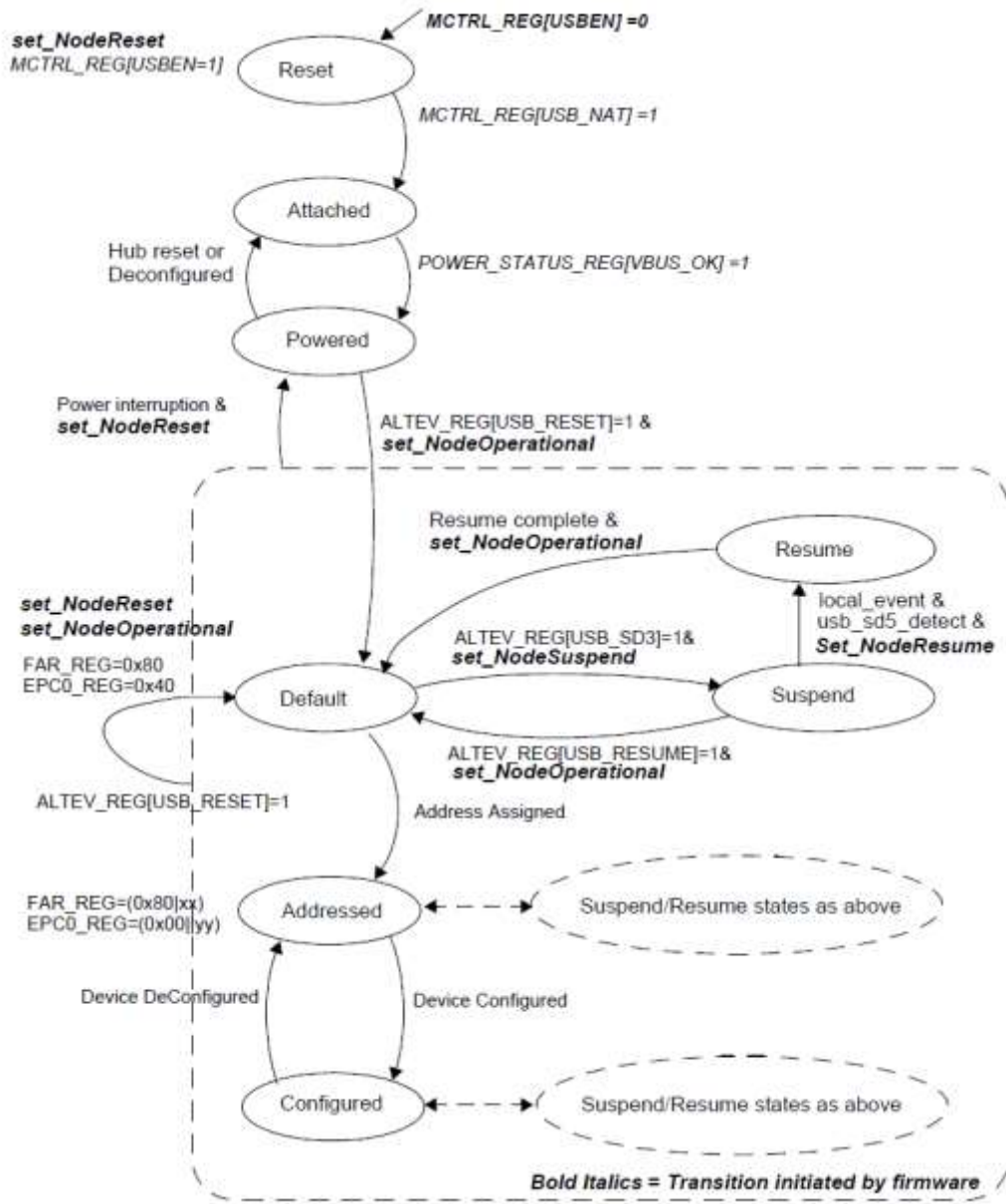

Figure 97. Node Functional State Diagram

Note 2 When the node is not in NodeOperational state, all registers are frozen except for the endpoint controller state machines and the TX_EN, LAST, and RX_EN bits which are reset.

Note 3 In NodeResume state, resume signaling is propagated upstream.

Note 4 In NodeSuspend state, the node may enter a low power state and is able to detect resume signaling.

Table 145: Functional States

State Transition	Condition Asserted
set_NodeReset	Node Functional State register NFS[1:0] bits are written with 00 _b The firmware should only initiate set_NodeReset if RESET in the ALTEV register is set.
set_NodeSuspend	Node Functional State register NFS[1:0] bits are written with 11 _b The firmware should only initiate set_suspend if SD3 in the ALTEV register is set.
set_NodeOperation	Node Functional State register NFS[1:0] bits are written with 10 _b
set_NodeResume	Node Functional State register NFS[1:0] bits are written with 01 _b The firmware should only initiate clear_suspend if SD5 in the ALTEV register is set.
usb_reset_detect	USB_RESET in the ALTEV register is set to 1.

State Transition	Condition Asserted
local_event	A local event that should wake up the USB.
usb_sd5_detect	USB_SD5 in the ALTEV register is set to 1.
usb_suspend_detect	USB_SD3 in the ALTEV register is set to 1.
usb_resume_detect	RESUME in the ALTEV register is set to 1.
resume_complete	The node should stay in NodeResume state for at least 10 ms and then must enter NodeOperational state to detect the EOP from the host, which terminates this Remote Resume operation. EOP is signaled when EOP in the ALTEV register is set to 1.

37.2.5 Address Detection

Packets are broadcasted from the host controller to all the nodes on the USB network. Address detection is implemented in hardware to allow selective reception of packets and to permit optimal use of microcontroller bandwidth. One function address with seven different endpoint combinations is decoded in parallel. If a match is found, that particular packet is received into the FIFO; otherwise, it is ignored.

Figure 98 shows the block diagram of the function address and endpoint decoding. The incoming USB Token, Packet Address field, and four bits Endpoint field are extracted from the incoming bit stream. The address field is compared to the Function Address register (FADR) and if a match is detected, the USB Endpoint field is compared to all EP bit fields in the Endpoint Control registers (EPCx). The transmit Endpoint Control registers are compared with IN tokens and the receive Endpoint Control registers are compared with OUT tokens. A match then enables the respective endpoint FIFO and transfers the payload data to/from the FIFO. Note that EPC0 is bidirectional and is enabled for IN, OUT, and SETUP tokens.

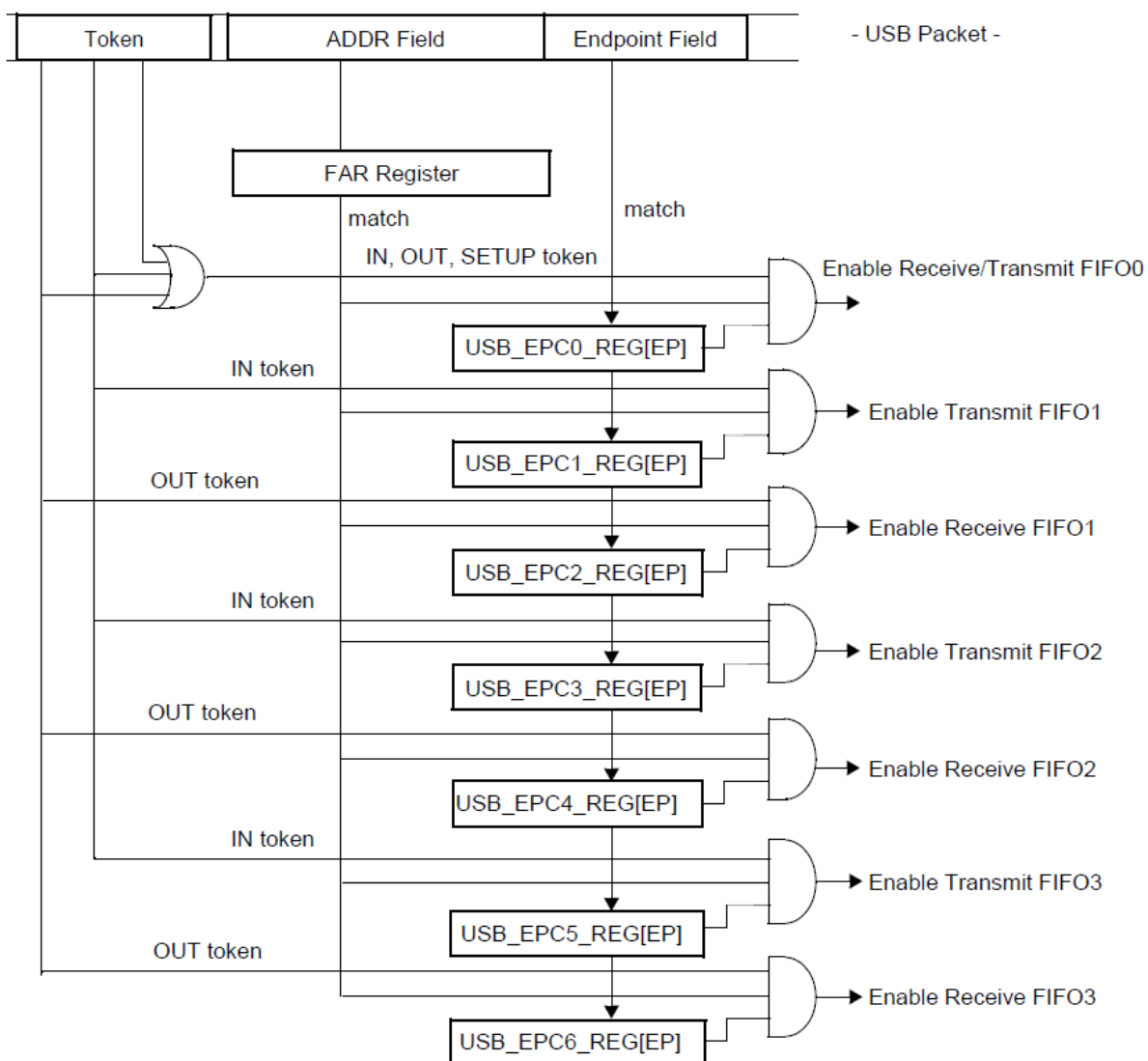

Figure 98. USB function address/endpoint decoding

37.2.6 Transmit and Receive Endpoint FIFOs

The FS/LS USB node uses a total of seven transmit and receive FIFOs: one bidirectional transmit and receive FIFO for the mandatory control endpoint, three transmit FIFOs, and three receive FIFOs. As shown in Table 146, the bidirectional FIFO for the control endpoint is 8 bytes deep. The additional unidirectional FIFOs are of 64 bytes each for both transmit and receive. Each FIFO can be programmed for one exclusive USB endpoint, used together with one globally decoded USB function address. The firmware must not enable both transmit and receive FIFOs for endpoint zero at any given time.

Table 146: USB Node Endpoint Sizes

Endpoint No.	TX FIFO		RX FIFO	
	Size (B)	Name	Size (B)	Name
0	8 FIFO0			
1	64	TXFIFO1 (IN)		
2			64	RXFIFO1 (OUT)
3	64	TXFIFO2 (IN)		
4			64	RXFIFO2 (OUT)
5	64	TXFIFO3 (IN)		

Endpoint No.	TX FIFO		RX FIFO	
	Size (B)	Name	Size (B)	Name
6			64	RXFIFO3 (OUT)

If two endpoints in the same direction are programmed with the same endpoint number [EP field] and both are enabled, data is received or transmitted to/from the endpoint with the lower number until that endpoint is disabled for bulk or interrupt transfers, or becomes full or empty for ISO transfers. For example, if receive EP1 and receive EP2 both use endpoint 3 and are both isochronous, the first OUT packet is received into EP1 and the second OUT packet into EP2, assuming no firmware interaction in between. For ISO endpoints, this allows implementing a ping-pong buffer scheme together with the frame number match logic. Endpoints in different directions programmed with the same endpoint number operate independently.

37.2.7 Bidirectional Control Endpoint FIFO0

FIFO0 should be used for the bidirectional control endpoint zero. It can be configured to receive data sent to the default address with the DEF bit in the EPC0 register.

The Endpoint 0 FIFO can hold a single receive or transmit packet with up to 8 bytes of data.

NOTE

A packet written to the FIFO is transmitted if an IN token for the respective endpoint is received. If an error condition is detected, the packet data remains in the FIFO and the transmission is retried with the next IN token.

The FIFO contents can be flushed to allow a response to an OUT token or to write new data into the FIFO for the next IN token.

Figure 99 shows the Endpoint 0 state machine. SETUP_FIX and STALL_FIX are always considered to be 0. With SETUP_FIX = 0, no state change will take place if a SETUP is received.

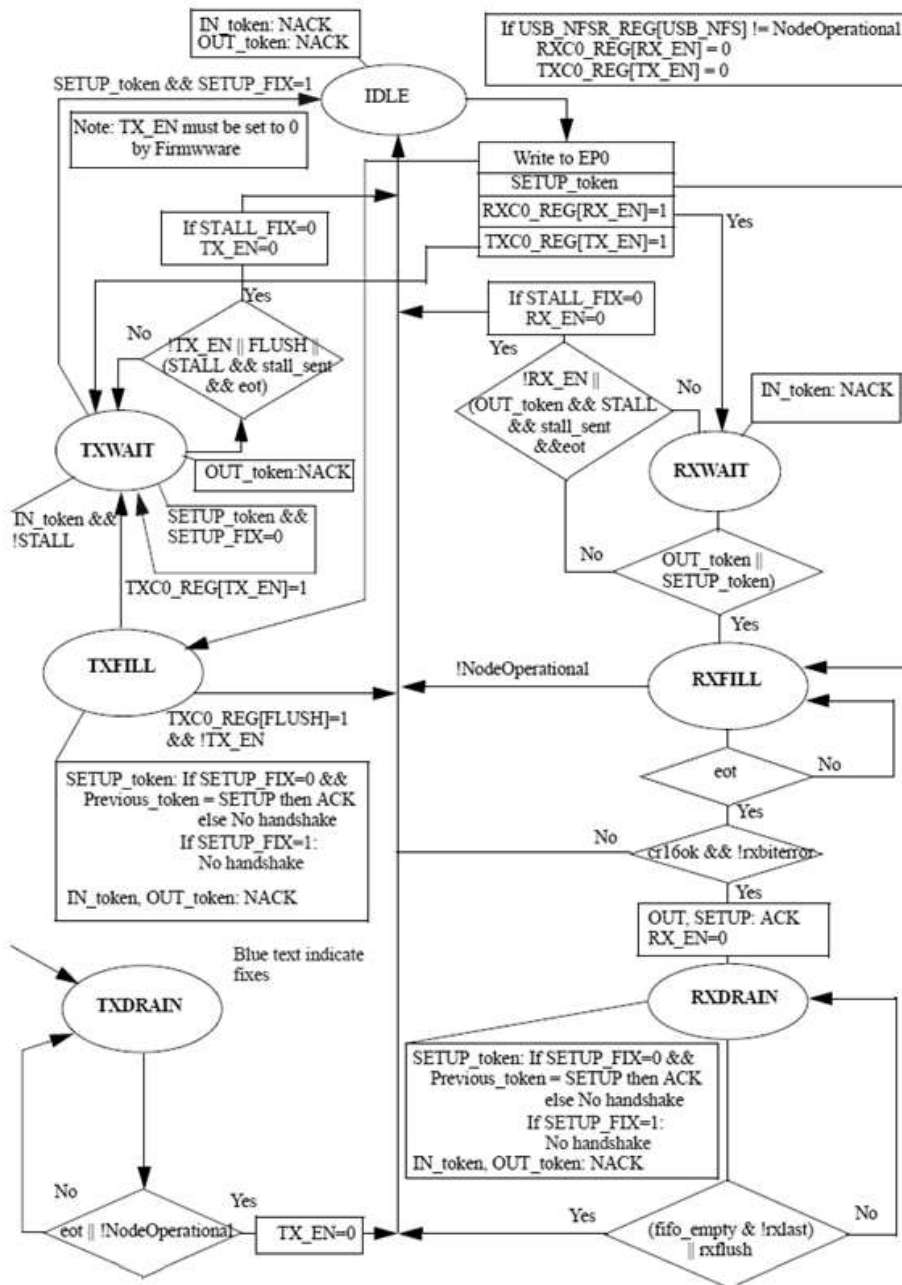

Figure 99. Endpoint 0 operation

37.2.8 Transmit Endpoint FIFO

The Transmit FIFOs for Endpoints 1, 3, and 5 support bulk and interrupt USB packet transfer larger than the actual FIFO size. Therefore, the firmware must update the FIFO contents while the USB packet is transmitted on the bus.

Figure 100 illustrates the operation of the transmit FIFOs.

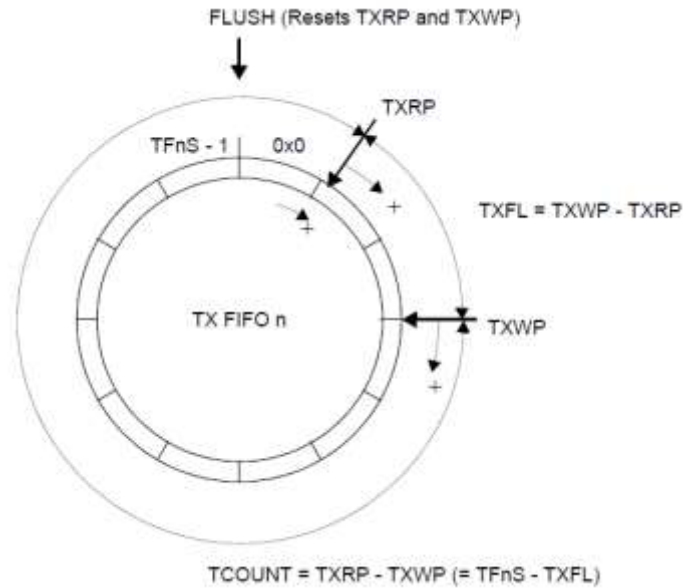

Figure 100. USB Tx FIFO operation

- **TFnS: Transmit FIFO n Size**

This is the total number of bytes available within the FIFO.

- **TXRP: Transmit Read Pointer**

This pointer is incremented every time the Endpoint Controller reads from the transmit FIFO. This pointer wraps around to zero if TFnS is reached. TXRP is never incremented beyond the value of the write pointer TXWP.

An underrun condition occurs if TXRP equals TXWP and an attempt is made to transmit more bytes when the LAST bit in the USB_TXCx_REG register is not set.

- **TXWP: Transmit Write Pointer**

This pointer is incremented every time the firmware writes to the transmit FIFO. This pointer wraps around to zero if TFnS is reached.

If an attempt is made to write more bytes to the FIFO than actual space available (FIFO overrun), the write to the FIFO is ignored and TCOUNT is checked for an indication of the number of empty bytes remaining.

- **TXFL: Transmit FIFO Level**

This value indicates how many bytes are currently in the FIFO.

A FIFO warning is issued if TXFL decreases to a specific value. The respective WARNn bit in the FWR register is set if TXFL is equal to or less than the number specified by the TFWL bit in the TXCn register.

- **TCOUNT: Transmit FIFO Count**

This value indicates how many empty bytes can be filled within the transmit FIFO. This value is accessible by firmware via the TXSn register.

37.2.9 Receive Endpoint FIFO

The Receive FIFOs for the Endpoints 2, 4, and 6 support bulk and interrupt USB packet transfer larger than the actual FIFO size. If the packet length exceeds the FIFO size, the firmware must read the FIFO contents while the USB packet is being received on the bus.

Figure 101 illustrates the operation of the receive FIFOs.

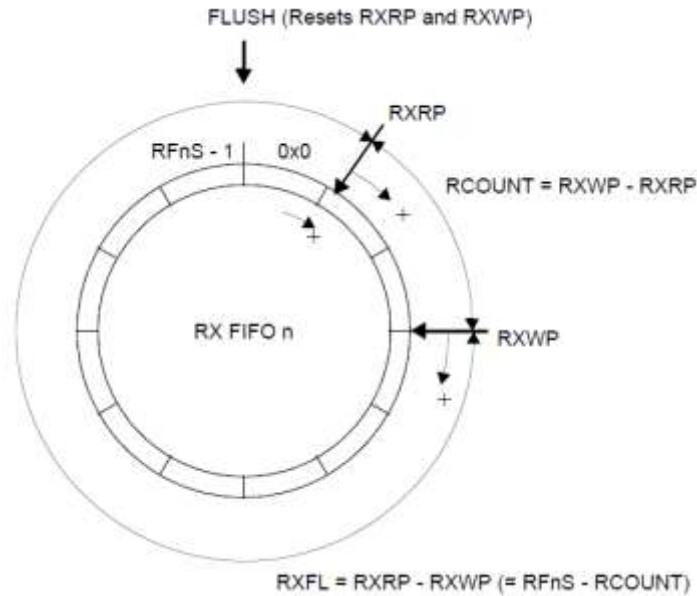

Figure 101. USB Rx FIFO operation

- **RFnS: Receive FIFO n Size**

This is the total number of bytes available within the FIFO.

- **RXRP: Receive Read Pointer**

This pointer is incremented with every read of the firmware from the receive FIFO. This pointer wraps around to zero if RFnS is reached. RXRP is never incremented beyond the value of RXWP.

If an attempt is made to read more bytes than the actually available bytes (FIFO underrun), the last byte is read repeatedly.

- **RXWP: Receive Write Pointer**

This pointer is incremented every time the Endpoint Controller writes to the receive FIFO. This pointer wraps around to zero if RFnS is reached.

An overrun condition occurs if RXRP equals RXWP and an attempt is made to write an additional byte.

- **RXFL: Receive FIFO Level**

This value indicates how many more bytes can be received until an overrun condition occurs with the next write to the FIFO.

A FIFO warning is issued if RXFL decreases to a specific value. The respective WARNn bit in the FWR register is set if RXFL is equal to or less than the number specified by the RFWL bit in the RXCn register.

- **RCOUNT: Receive FIFO Count**

This value indicates how many bytes can be read from the receive FIFO. This value is accessible by firmware via the RXSn register.

37.2.10 Interrupt Hierarchy

Figure 102 shows the register hierarchy for generating USB interrupt events. Each bit in the event register can be masked by setting the corresponding bit in the xxxMSK_REG. A USBFS_IRQ to the CPU is generated if one or more bits in the MAEV_REG are set and the corresponding bits in the MAMSK_REG are set to 1. Bit 7 in the MAMSK_REG is a global interrupt enabled for the USBFS_IRQ.

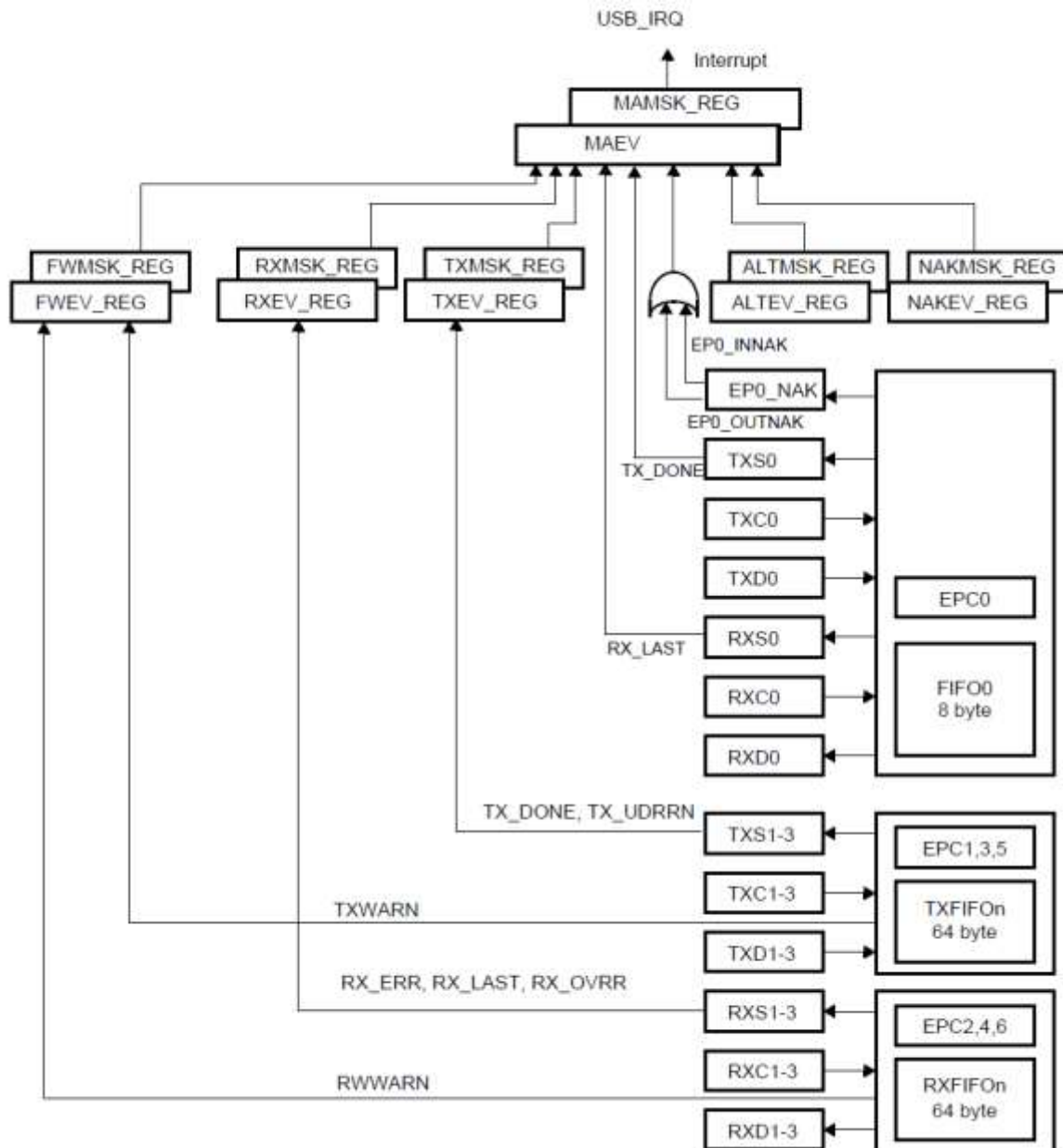

Figure 102. USB Interrupt register hierarchy

37.2.11 USB Power Saving Modes

In NodeSuspend state the USB transceiver is automatically switched to a low power mode. Optimal power saving rest of the chip level can be obtained by:

- Executing from on-chip RAM or ROM. On-chip access is more power efficient than external memory access. With external FLASH, appropriate gating of the chip selects may be applied
- Switching the PLL to bypass mode and then switching it off (CLK_CTRL_REG=0)
- Switching XTAL supply to AVD1 (AVD_SUPPLY=1, default state)
- Switching off AVD_XTAL (LDO_XTAL_ON = 0) to eliminate current through external potentiometers
- Switching off DCDC converter, LED current, GenDSP, and others
- Setting bandgap at the lowest voltage and internal current (BANDGAP_REG = 0x8)
- Enable LDO_SUSPEND and switch off CHARGE control circuit.

Note that the XTAL cannot be switched off. So, there is always a clock available for interrupt generation and keyboard scanning.

In suspend mode, any activity on the USB generates the USB_ALTEV[RESUME] interrupt.

The firmware must respond by:

- Starting the PLL and switching the system clock from XTAL to PLL mode to provide 48 MHz to the USB clock.
- Re-enabling all functions and setting that have been turned off to reduce the currents in suspend mode.

Note that the total time needed to bring the USB module back to operational mode is determined by the PLL startup time.

The CPU resumes normal operation after USB_NFSR register is set in NodeOperational state.

37.2.11.1 Freezing USB Node

The USB module provides support for an In-System-Emulator. If SET_FREEZE_REG[FRZ_USB] is set, the USB module will exhibit the following behaviors:

- The automatic Clear-on-Read function of status flags is disabled.
- The FIFOs are not updated.

To enable the module, the RESET_FREEZE_REG[FRZ_USB] must be set to 1 again.

37.2.11.2 Integrated Resistors

The USB transceiver has integrated resistors as specified in *USB Specification 2.0 ECN "pull-up/pull-down resistors"*.

The resistors switching can be overruled as shown in [Figure 103](#) and [Figure 104](#), if USB_UX20CDR_REG[RPU_TEST_EN] = 1.

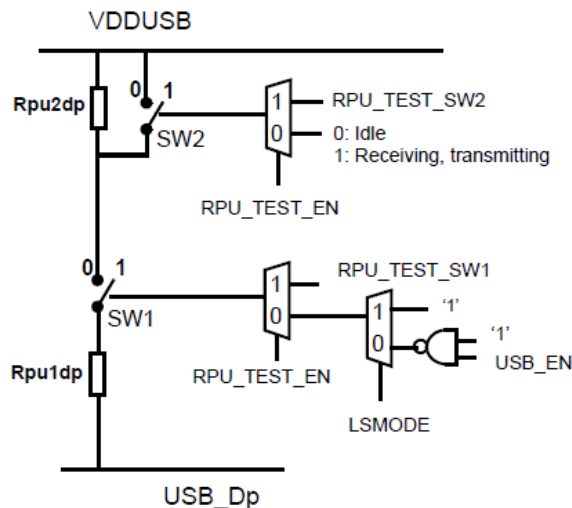

Figure 103. USB_Dp resistor switching

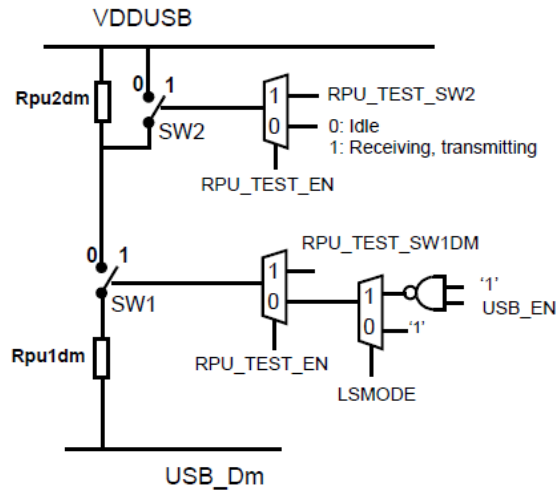

Figure 104. USB_Dm resistor switching

38. Haptic Driver

Device:	DA14691	DA14695	DA14697	DA14699
Feature Availability:	x	x	✓	✓

38.1 Introduction

The haptic feedback driver and controller in DA1469x can be used in conjunction with external devices of type Linear Resonant Actuator (LRA) or Eccentric Rotating Mass (ERM). It automatically adapts to the resonant frequency of the haptic feedback actuator and has a configurable supply current to set the force of the haptic feedback. Furthermore, active acceleration and rapid stop functionality is implemented, enabling short bursts of haptic feedback to represent, for example, typing on a keyboard while using a touch screen.

Features

- Fully digitally controlled drive current
- Fully digitally and software controlled resonant frequency search
- Differential output driver capable of LRA and ERM
- Automatic LRA resonant frequency tracking within +/- 20 % of programmed frequency
- “Active acceleration” and “rapid stop” technology for crisper haptic pattern generation, fully software controlled
- Built-in short circuit protection
- Edge Rate Control for minimized EMI
- Minimized power consumption in IDLE Mode
- 250 mA max output current.

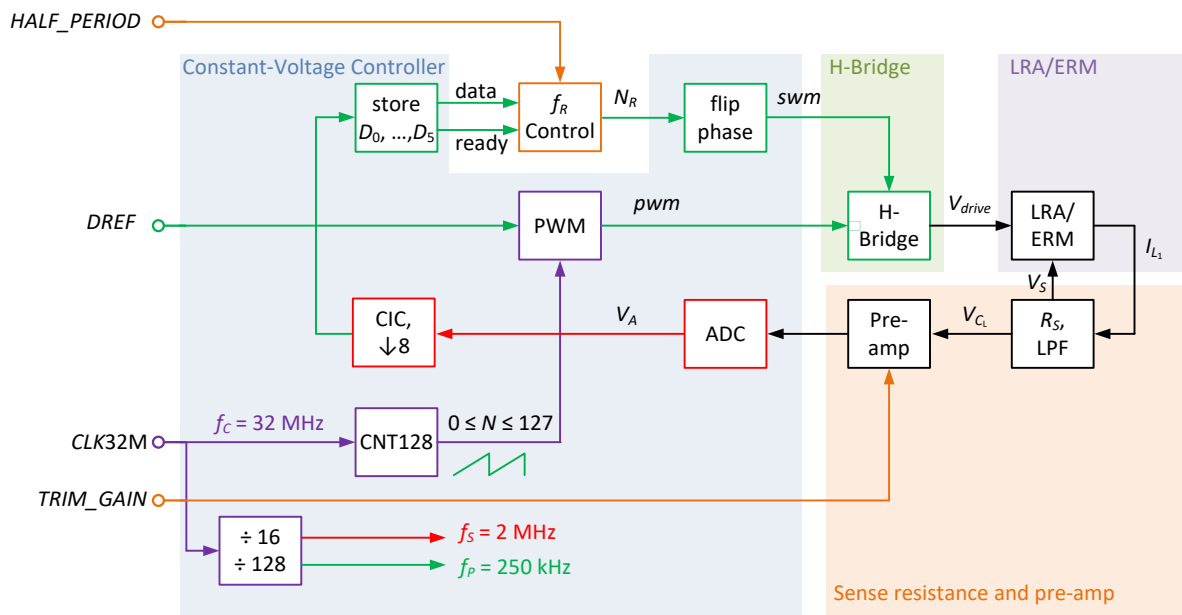

Figure 105. Block diagram of the haptic driver

38.2 Architecture

The haptic feedback driver architecture is shown in Figure 105. It has the following subblocks:

- Clock dividers:
 - The system operates on the 32 MHz clock (system clock) and generates local frequencies of 2 MHz and 250 kHz, which are divided by 16 and 128, respectively.
 - Conceptually, a ramp generator (CNT128) provides a 250 kHz signal used for generating the pulse width modulation control for the H-bridge driver.
- Pulse Width Modulator (PWM):

- The 250 kHz ramp signal is compared with the value LRA_CTRL3_REG[DREF] to generate a square wave signal to drive the H-bridge with a variable duty cycle.
- The placement of the activation pulse can be controlled with LRA_CTRL2_REG[PWM_MODE] at the beginning/end of or in the middle of the period. The placement can also alternate between these settings to control the harmonic content of the supply current.
- Flip Phase:
 - A programmable activation frequency of the LRA/ERM can be configured by LRA_CTRL2_REG[HALF_PERIOD] in multiples of 4 μ s.
 - For applications using an ERM, it is sufficient to set it to a fixed value.
 - For applications using an LRA, its value must track the resonant frequency of the external component, which is notoriously sensitive to a range of environmental conditions. Refer to Section 38.2.1 for a detailed explanation.
- H-Bridge driver:
 - Fully configurable for edge rate control (ERC) and short circuit protection (SCP).
 - These configurations can be optimized using LRA_BRD_LS_REG and LRA_BRD_HS_REG for the low and high side of the bridge, respectively.
- LRA/ERM, external components to close the controller loop:
 - A wide range of haptic feedback devices is supported with a maximum load current up to 250 mA.
- Sense resistance (R_s) and low-pass filter:
 - The nominal value of R_s is 1 Ω but varies by up to ± 20 % due to process variations. These variations should be calibrated to fix the loop gain.
 - The sense resistance is applied on both sides of the H-Bridge and the appropriate sense voltage is automatically connected to the pre-amp via a low-pass filter to minimize the switching transients.
- Pre-Amplifier:
 - As the maximum current is limited to 250 mA, the sense voltage is nominally limited to 20 mV and thus may be amplified to exploit the full range of the subsequent ADC.
 - Depending on the desired load current, the pre-amplifier gain may be configured to six, eight (default), 10, or 12. The highest gain factor is meant to be used for the least desired current settings and the gain settings of six and 10 are meant to partially compensate the gain variations due to process tolerance of the sense resistance.
- Analog to Digital Converter (ADC):
 - The 10-bit sense voltage is padded with zeros to a 16-bit signed representation with eight fractional bits.
 - The sampling rate is 2 MHz.
 - The offset voltage representing zero load current can be compensated by programming LRA_ADC_CTRL1_REG[LRA_ADC_OFFSET] to have an 8-bit signed value and three fractional bits.
- Cascaded Integrator Comb (CIC) filtering and decimation by a factor of eight:
 - This block computes a running mean and decimates the sense signal to the control rate of 250 kHz.
- Store D_1, \dots, D_8 :
 - During each phase of the actuation (a half period), eight samples are stored at equidistant sample times. These samples can be used to aid resonant frequency tracking.
 - During the first half period, samples D_1 through D_8 are stored and during the second half period, samples D_9 through D_{16} are stored.
 - The samples are stored in LRA_FLT_SMP $_x$ _REG[LRA_SMP_ $(2x - 1)$, LRA_SMP_ $2x$] with $1 \leq x \leq 8$.
 - After a specific sample given by LRA_CTRL1_REG[IRQ_IDX] is stored, an interrupt is generated to trigger calculation of the updated value of LRA_CTRL2_REG[HALF_PERIOD]. When the index is set to 0xF, the interrupt is generated after sample 16 is stored. When the index is set to 0x7 (default), the interrupt is generated both after sample 8 is stored and after sample 16 is stored. This functionality is useful when the load behaves in a symmetric fashion.

38.2.1 Resonance Control

When an LRA is used as a load, the resonant frequency of the external device must be tracked across a wide range of environmental variations to maintain a constant haptic feedback force.

In constant voltage mode, the steady state current in the LRA is set by the series resistance R_1 as shown in Figure 106, modulated by the back-electromotive-force (back-EMF) generated by the parallel resonant circuit L_2, C_1, R_2 in the same figure. When resonance is achieved, the current in the device represents a square wave with a dip in each half curve representing half a sinusoidal. The sense signal is a linear representation of this load current.

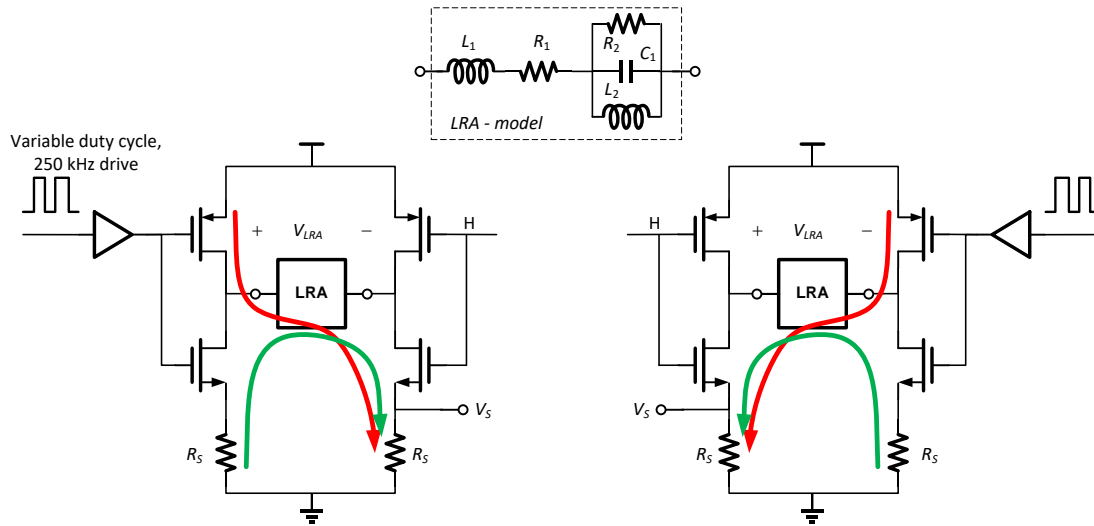

Figure 106. Circuit diagram of the Haptic Driver and Equivalent electrical model of an LRA

The mathematical background is given here for reference. The LRA is driven by pulse width modulated signals, and the polarity of this PWM signal is changed every half period $T/2$. The amplitude of the LRA response is proportional to pulse width of the PWM signal. We can approximate the voltage drives as:

$$v(t) = P \cdot V \tag{1}$$

In the equation above, the polarity $P = +1$ or -1 :

$$\begin{aligned} \text{when } \text{mod}(t, T) < \frac{T}{2}, P = 1, \\ \text{Otherwise, } P = -1 \end{aligned}$$

We can approximate the response of the LRA as:

$$x(t) = A \cos(\omega t) + B \sin(\omega t) \tag{2}$$

where $\omega = \frac{2\pi}{T}$, A is the 'in phase' amplitude, and B is the 'quadrature' amplitude.

A simplified equation describing the electrical behavior of the system is:

$$v(t) = R_1 i(t) + \varphi \frac{d}{dt} x(t) \tag{3}$$

where R_1 is the DC resistance and φ is a constant that translates currents into forces.

The LRA control system measures the current relative to the polarity of the voltage during a constant voltage segment:

$$i_M(t) = P \cdot i(t) = \frac{V}{R_1} - \omega A \sin(\omega t) + \omega B \cos(\omega t) \tag{4}$$

Every half a period, the LRA control algorithm does a least squares fit a constant, sine and cosine term to the measured current $i_M(t)$, and adjust the phase and the frequency of the drive signal $v(t)$ such that $B = 0$ and A is positive (or negative for fast breaking). The amplitude of the LRA response is directly proportional to the sine

term. The sine term can be used as input for a secondary control loop that varies the drive strength in such a way that the desired response amplitude A is achieved in minimal time (overdrive).

The software provided as part of the SDK approximates the sense signal with a combination of a constant value, a sine function, and a cosine function, elucidating to what degree the drive signal is tuned to the resonant frequency. The result is used to update the value of HALF_PERIOD in accordance to the resonant frequency.

38.3 Programming

The haptic feedback driver supports ERM and LRA devices. It has two basic means of operation:

- ERM can be setup for a desired force with a specific duty cycle pre-set using LRA_CTRL3_REG[DREF]. The enable signal LRA_CTRL1_REG[LRA_EN] switches it on and off.
- LRA can operate at varying strengths. For optimal usage, LRA needs to be actuated at its resonant frequency. This resonance depends on various factors (temperature, orientation, movement, humidity, and others), hence it needs to be controlled.

There is a simple sequence of steps that need to be followed:

1. Configuration:

Pre-set the desired initial conditions for the actuation frequency (LRA_CTRL2_REG[HALF_PERIOD]), the current amplitude (LRA_CTRL3_REG[DREF]), and the initial duty cycle of the constant current controller (LRA_CTRL3_REG[DREF]).

There are two operational modes:

- Constant current mode: it is enabled by default.
- Constant duty cycle mode: it can be selected by setting the state-space filter coefficients to 0 (LRA_FLT_COEFn_REG, with $n = 1, 2,$ and 3) and selecting the ADC output samples (LRA_CTRL1_REG[SMP_SEL]) to be stored for the resonance control algorithm. Note that the values of the above registers should be chosen according to the external haptic device used.

2. Enable/Disable:

Setting the LRA_CTRL1_REG[LRA_EN] bit enables the haptic feedback; hence the current is controlled automatically. However, the resonant frequency remains at its initial setting.

3. Resonance Control:

To track the resonant frequency, an interrupt-controlled software loop needs to be activated. Every half cycle of the actuation (around 2.5 ms intervals, when resonance frequency is set at 200 Hz) an interrupt is generated which should trigger the Cortex-M33 to run the code routine, reading up to eight automatically stored samples, calculating the updated resonant frequency, and writing it back to the register.

- #### 4. Amplitude Modulation:
- If an amplitude modulation is required, the patterns that adjust the current over time should run in software. A special case of amplitude modulation, like the fast start-up and rapid stop functionality, which requires abrupt pulses (that is, typing sensation on a touch screen), can also be implemented in software.

38.4 Legal

NOTWITHSTANDING ANYTHING TO THE CONTRARY IN THIS DOCUMENT OR IN ANY OTHER AGREEMENT, CUSTOMER ACKNOWLEDGES THAT THE PRODUCTS ARE PROVIDED WITHOUT ANY WARRANTY OF NON-INFRINGEMENT, AND THAT IF ANY LICENSE OR RIGHT IS REQUIRED TO BE OBTAINED FROM ANY THIRD PARTY, THIS RESPONSIBILITY SHALL REST SOLELY WITH CUSTOMER.

39. LEDs Driver

Device:	DA14691	DA14695	DA14697	DA14699
Feature Availability:	x	x	✓	✓

39.1 Introduction

The LED driver features two matched white LED outputs with an absolute accuracy of +/-5 %. It supports two solutions for brightness dimming: a selectable output load current and PWM dimming.

The selectable output load is a dimming mode that changes the brightness by changing/reducing the maximum output current. It is controlled by three bits (eight possible settings). The minimum setting is 2.5 mA with an increment of 2.5 mA, so maximal 20 mA. The reduced current settings are especially interesting to be used as a coarse brightness control for short pulses, for example, for a heart rate monitor application.

PWM dimming changes the brightness by modulating the output current from 0 % to 100 % duty-adjustable pulse. The LED brightness is controlled by adjusting the relative ratios of the on and off times. Since the dimming frequency (timer operating on the low power clock) is higher than the human-eye sensitive range (>100 Hz), the effective brightness is perceived by averaging the on and off times. The PWM operation is possible for all eight load settings instead of just the maximum setting.

The block diagram of just one driver is presented in [Figure 107](#). Two of these are instantiated in the system.

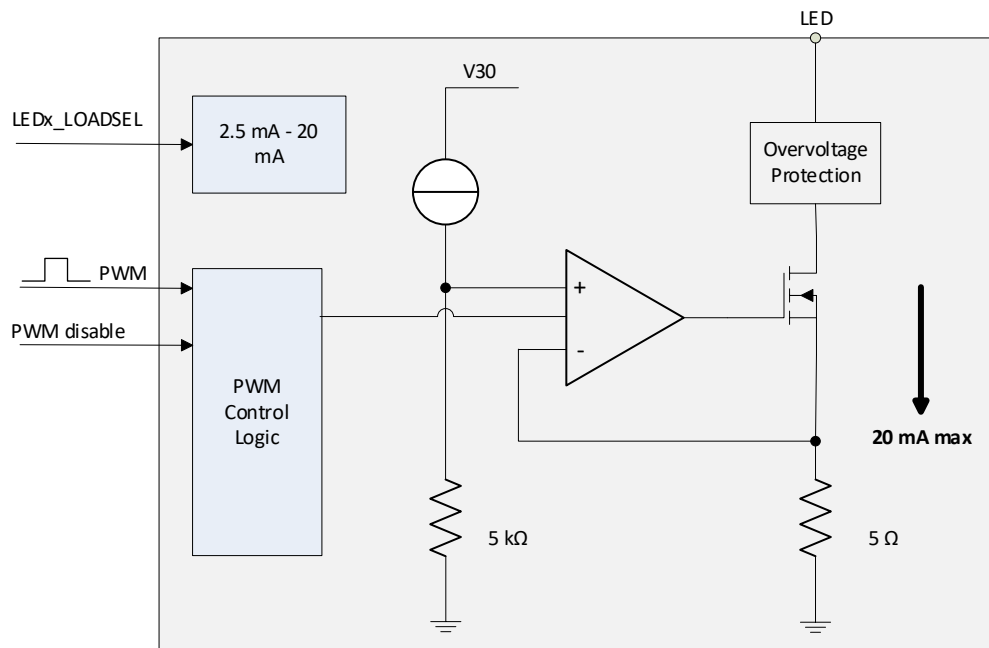

Figure 107. LED Driver block diagram

39.2 Architecture

The LED driver contains the following functional blocks:

- Output load setting. Input is an accurate reference current from a bandgap, and outputs are various (mirrored) currents
- High gain op-amp
- Matched resistor network
- PWM control logic
- Overvoltage protection.

A reference current, coming from the bandgap, is mirrored into selectable output current(s). This current is routed through a resistor, resulting in a reference voltage on the positive input of the op-amp. Due to the negative feedback and the high gain, the op-amp in combination with the output transistor tries to force the same

voltage on the negative input and over the output resistor, resulting in the selected output load current. The overvoltage protection shields the LED driver from excessive high voltages, which can be up to VBUS max, on the LED pins.

Note that, the LED driver requires biasing currents which are only available if the Bandgap is activated. Hence, no LED driver operation is feasible during any sleep modes where Bandgap is disabled and only periodically refreshed.

39.3 Programming

There is a simple sequence of steps that needs to be followed to program the LED drivers:

1. Define the PWM frequency and duty cycle for each LED driver by configuring PWMLD_DUTY_CYCLE_LED1/2_REG and PWMLD_FREQUENCY_REG. Note that it is possible to use different duty cycles for the two drivers, however they share the same frequency configuration register
2. Configure the sinking current by programming PWMLD_CTRL_REG[LEDx_LOAD_SEL]. This defines the sinking current according to the following formula:

$$I_{LED(sink)} = 2.5 \text{ mA} + (LEDx_LOAD_SEL \times 2.5 \text{ mA}) \quad (5)$$

3. Enable the LED drivers by asserting PWMLD_CTRL_REG[LED1_EN, LED2_EN].
4. Activate PWM by asserting PWMLD_CTRL_REG[PWM_ENABLE].

Note that the PWM can be stopped by writing to either SET_FREEZE_REG[FRZ_PWMLD] or PWMLD_CTRL_REG[SW_PAUSE_EN]. Furthermore, the control logic of the LEDs resides in PD_PER. PD_COM can be switched off during sleep with no impact on the LEDs operation.

40. Input/Output Ports

Device:	DA14691	DA14695	DA14697	DA14699
P1_12 to P1_22:	x	x	✓	✓

40.1 Introduction

The DA1469x has software-configurable input/output (I/O) pin assignment organized into ports Port 0 and Port 1.

Features

- Port 0 has 32 pins and Port 1 has 23 pins (including M33_SWCLK, M33_SWDIO, CMAC_SWCLK, and CMAC_SWDIO)
- Fully programmable pin assignment (PPA)
- Selectable pull-up and pull-down resistors of 25 kΩ per pin
- Programmable open-drain functionality
- Pull-up voltage at V30/V18P voltage configurable per pin
- Fixed assignment for analog pin, motor controller, and LCD controller pins
- Pins can retain their last state when system enters the Extended, Deep Sleep, or Hibernation mode.

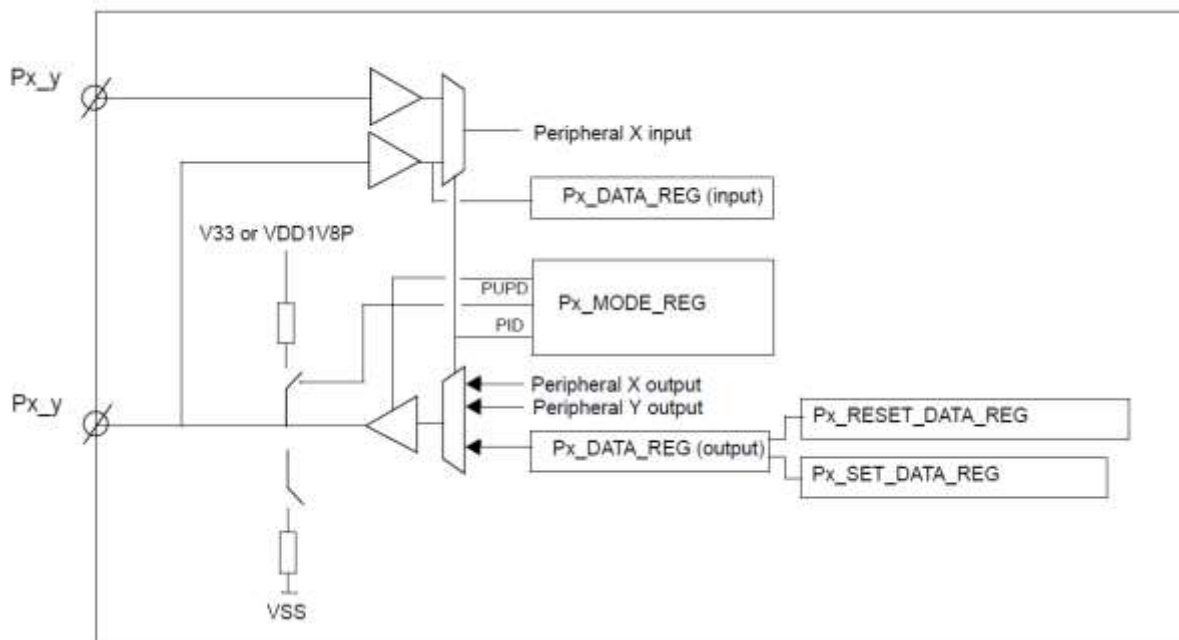

Figure 108. Port P0 and P1 with Programmable Pin Assignment

40.2 Architecture

40.2.1 Programmable Pin Assignment

The Programmable Pin Assignment (PPA) provides a multiplexing function to the I/O pins of on-chip peripherals. Any peripheral input or output signals can be freely mapped to any I/O port bit by setting `Px_yy_MODE_REG[5:0]`

0x00 to 0x3B: Peripheral IO ID (PID)

Refer to the `Px_yy_MODE_REGS` for an overview of the available PIDs. Analog, GPADC, and SDADC signals have fixed pin assignment to limit interference with the digital domain. The same applies to Motor and LCD Controller signals. The M33_SWD interface is mapped on P0_10 and P0_11 and the CMAC_SWD interface on P0_12 and P0_13.

40.2.1.1 Priority

The firmware has the possibility to assign the same peripheral output to more than one pin. It is users' responsibility to make a unique assignment.

In case more than one input signals are assigned to a peripheral input, the left most pin in the lowest port pin number has priority, for example, P0_00_MODE_REG has priority over P0_01_MODE_REG.

40.2.1.2 Direction Control

The port direction is controlled by setting Pxy_MODE_REG[9:8].

In output mode and analog mode, the pull-up/down resistors are automatically disabled.

40.2.2 General Purpose Port Registers

The general-purpose ports are selected with PID = 0. The port function is accessible through registers:

- Px_DATA_REG: Port data input/output register
- Px_SET_OUTPUT_DATA_REG: Port set output register
- Px_RESET_OUTPUT_DATA_REG: Port reset output register.

40.2.2.1 Port Data Register

The registers input Px_DATA_REG and output Px_DATA_REG are mapped on the same address.

The data input register (Px_DATA_REG) is a read-only register that returns the current state on each port pin even if the output direction is selected, regardless of the programmed PID, unless the analog function is selected (in this case it reads 0). The Cortex-M33 CPU can read this register at any time even when the pin is configured as an output.

The data output register (Px_DATA_REG) holds the data to be driven on the output port pins. In this configuration, writing to the register changes the output value.

40.2.2.2 Port Set Data Output Register

Writing a 1 in the set data output register (Px_SET_DATA_REG) sets the corresponding output pin. Writing a 0 is ignored.

40.2.2.3 Port Reset Data Output Register

Writing a 1 in the reset data output register (Px_RESET_DATA_REG) resets the corresponding output pin. Writing a 0 is ignored.

40.2.3 Fixed Assignment Functionality

There are certain signals that have a fixed mapping on specific general purpose IOs. This assignment is shown in [Table 147](#).

Table 147: Fixed assignment of specific signals

GPI O	SWD (Note 2)	QSPI RAM	Analog (Note 3)	Clock s (Note 4)	PWM (Note 8)	Motor controller	LCD controller (Note 5)	Diagnostics
P0_00		QSPIR_D0				PG3_4		
P0_01		QSPIR_D1				PG4_2		
P0_02		QSPIR_D2				PG4_1		
P0_03		QSPIR_D3				PG3_2		
P0_04		QSPIR_CS				PG3_1		
P0_05		QSPIR_CLK				PG3_3		
P0_06			SDADC_GND					
P0_07			NTC Input					
P0_08			GPADC_2 \ SDADC_2			PG4_3		
P0_09			GPADC_3 \ SDADC_3			PG4_4		
P0_10	M33_SWD IO							
P0_11	M33_SWCLK							
P0_12	CMAC_SWDIO			XTAL32M				
P0_13	CMAC_SWCLK			RC32M				
P0_14				XTAL32k				
P0_15				DIVN				
P0_16			SDADC_REF	RCX				WOKENUP or CMAC_SLP_TIMER_EXPIRE (Note 7)
P0_17				RC32k		PG2_1		
P0_18						PG2_2		CMAC_DIAG_7 (Note 6)

Multi-Core Bluetooth 5.2 SoC Family with System PMU

GPI O	SWD (Note 2)	QSPI RAM	Analog (Note 3)	Clocks (Note 4)	PWM (Note 8)	Motor controller	LCD controller (Note 5)	Diagnostics
P0_19						PG2_3		CMAC_DIAG_6 (Note 6)
P0_20						PG2_4		CMAC_DIAG_5 (Note 6)
P0_21						PG1_3		CMAC_DIAG_4 (Note 6)
P0_22								
P0_23								
P0_24						PG1_4	LCD_TE	CMAC_DIAG_3 (Note 6)
P0_25			GPADC_1 \ SDADC_1					BANDGAP_ENABLE (Note 7)
P0_26						PG0_1	LCD_VCK	CMAC_DIAG_13 (Note 6)
P0_27						PG0_2	LCD_ENB/PLCD_ENAB	CMAC_DIAG_12 (Note 6)
P0_28						PG0_3	LCD_VST/PLCD_VSYNC	CMAC_DIAG_11 (Note 6)
P0_29						PG0_4	LCD_HCK/PLCD_CLK	CMAC_DIAG_10 (Note 6)
P0_30						PG1_1	LCD_HST/PLCD_HSYNC	CMAC_DIAG_9 (Note 6)
P0_31						PG1_2	LCD_XRST	CMAC_DIAG_8 (Note 6)
P1_00			NTC Supply					
P1_01					Timer.PWM			
P1_02							LCD_BLUE0	
P1_03							LCD_BLUE1	
P1_04							LCD_GREEN0	
P1_05							LCD_GREEN1	
P1_06					Timer.PWM2			CMAC_DIAG_14 (Note 6)
P1_07							LCD_RED0	
P1_08							LCD_RED1	

GPI O	SWD (Note 2)	QSPI RAM	Analog (Note 3)	Clocks (Note 4)	PWM (Note 8)	Motor controller	LCD controller (Note 5)	Diagnostics
P1_09			GPADC_0 \ SDADC_0					CMAC_DIAG_15 (Note 6)
P1_10							LCD_VCOM / LCD_FRP / LCD_EXTCOMIN	
P1_11							LCD_XFRP	
P1_12			GPADC_5					
P1_13			GPADC_4				LCD_VCK	
P1_14			SDADC_4				LCD_ENB / PLCD_ENAB	
P1_15							LCD_VST / PLCD_VSYNC	
P1_16							LCD_HCK / PLCD_CLK	
P1_17							LCD_HST / PLCD_HSYNC	
P1_18			GPADC_6					
P1_19			GPADC_7					
P1_20			SDADC_5					
P1_21			SDADC_6				LCD_XRST	
P1_22			SDADC_7				LCD_TE	

Note 2 The SWD signals mapping is defined by SYS_CTRL_REG[DEBUGGER_ENABLE] and SYS_CTRL_REG[CMAC_DEBUGGER_ENABLE]. However, these signals are mapped on the ports by default.

Note 3 The ADC case can be selected by the PID bit field on the respective Px port.

Note 4 Enable specific clock outputs through GPIO_CLK_SEL_REG register.

Note 5 Refer to LCD Controller chapter to choose the correct LCD pinning combination between the available LCD interfaces.

Note 6 CMAC_DIAG_[2:0] can be assigned to any GPIO through the Programmable Pin Assignment (PPA). For a complete functionality description of the CMAC diagnostics, see Section 14.2.2 Configurable MAC (CMAC).

Note 7 PMU_CTRL_REG[MAP_BANDGAP_EN].

Note 8 Timer.PWM and Timer.PWM2 signals are available during sleep (CLK_TMR_REG[TMR_PWM/2_AON_MODE]).

40.2.4 GPIO State Retention While Sleeping

Before setting the system to any sleep modes, the state of the pads needs to be retained to avoid external components being affected by the GPIOs changing states when the system goes to sleep and to avoid any floating driving signals from shut-off power domains leading to increasing power dissipation.

The state of the pads is automatically latched by always-on latches by setting the corresponding PAD_LATCH_EN bit in the Px_RESET_PAD_LATCH_REG. These bits latch the digital control signals going into the pad and latch the data output separately for each pin. Hence, if the pad has been set as an output driving high, it retains its precise state. Px_SET_PAD_LATCH_REG is used to unlatch the pins.

The signals in red in [Figure 109](#) and [Figure 110](#) are latched.

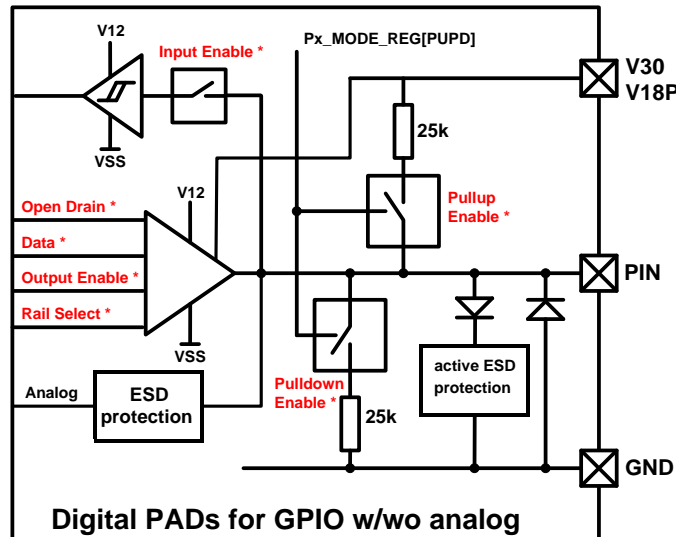

Figure 109. Latching of digital pad signals

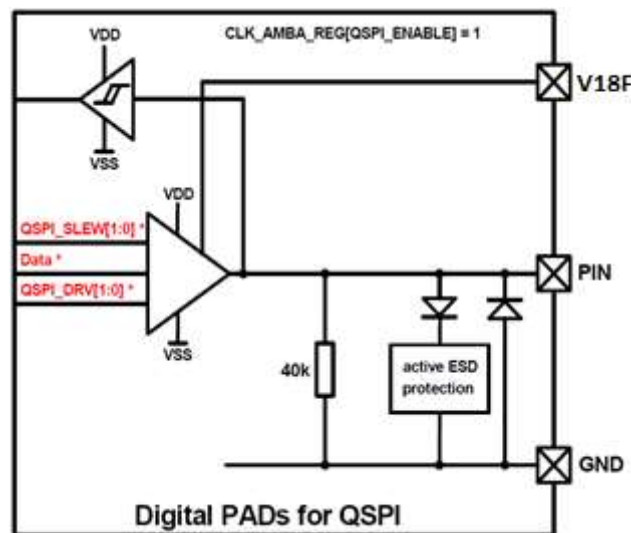

Figure 110. Latching of QSPI pad signals

After the system waking up, the software must disable the latching by setting the corresponding PAD_LATCH_EN bits of the Px_PAD_LATCH_REG so that all pads can be accessed and controlled again.

For QSPI pads, the pad latching is overwritten by the QSPI controller as soon as the clock of the controller is enabled.

40.2.5 Special I/O Considerations

There are certain considerations in using the GPIOs:

- To use P0_14 or P0_15 in GPIO mode, USBPAD_REG[USBPAD_EN] must be set. However, the levels allowed on these pins are 0 V and 3 V. The voltage comes from the V30 rail. If 1.8 V is selected as the pin supply, a current of 150 μ A is to be expected. Moreover, these pins should not be used in sleep modes, because the USBPAD_REG which belongs to the system power domain is powered off in sleep modes and those pins do not support state retention during power down.
- P0_18, P0_16, P1_00, P0_07, P1_09, P0_27(VFBGA86) and P0_16, P1_00, P1_06, P0_18, P0_06, P0_07(VFBGA100) GPIOs might affect the performance of radio and XTAL32MHz crystal oscillator when being toggled while RF activity occurs or XTAL32MHz oscillates. It is recommended to use them at low speed and not to use them when radio is active. If used as outputs, the weak-drive capability should be selected (weak-drive capability does not apply to all the above GPIOs).
- P1_12, P1_18, and P1_19 might affect XTAL32K performance when being toggled at high frequencies while XTAL32K is in use. It is recommended to use them at low speed when set as outputs.
- P0_12 and P0_13 are by default connected to CMAC_SWDIO and CMAC_SWCLK. If GPIO function is needed they must be programmed accordingly.

41. Radio

Device:	DA14691	DA14695	DA14697	DA14699
Feature Availability:	✓	✓	✓	✓

41.1 Introduction

The Radio Transceiver provides a 103 dB RF link budget for reliable wireless communications. All RF blocks are supplied by on-chip low dropout regulators (LDOs). The bias scheme is programmable and optimized for minimum power consumption. The radio block diagram is given in Figure 111. It comprises the Receiver, Transmitter, Synthesizer, Rx/Tx combiner block, and Biasing LDOs.

Features

- Single ended RFIO interface, 50 Ω matched
- Alignment free operation
- -97 dBm receiver sensitivity
- Configurable transmit output power from -18 dBm up to 6 dBm
- Ultra-low power consumption
- Fast frequency tuning minimizes overhead

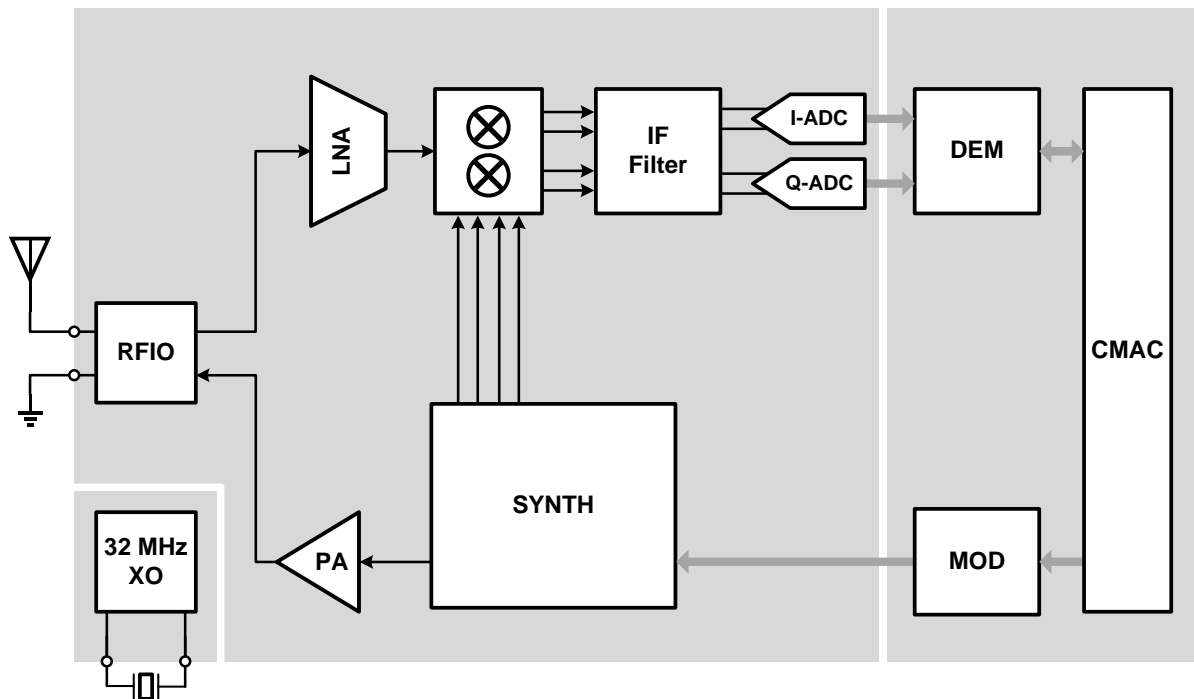

Figure 111. Radio block diagram

41.2 Architecture

41.2.1 Receiver

The RX frontend consists of a selective matching network, a low noise amplifier (LNA), and an image rejection down conversion mixer. The intermediate frequency (IF) part of the receiver comprises a filter with programmable gain. The LNA and IF Filter gains are controlled by the AGC. This provides the necessary signal conditioning prior to digitalization. The digital demodulator block (DEM) provides a synchronous bit stream.

41.2.2 Synthesizer

The RF synthesizer generates the quadrature LO signal for the mixer. It also generates the modulated TX output signal. The DCO runs at twice the required frequency and a dedicated divide-by-two circuit generates the

2.4 GHz signals in the required phase relations. The reference frequency is the 32 MHz crystal clock. The modulation of the TX frequency is performed by two-point modulation.

41.2.3 Transmitter

The RF power amplifier (RFPA) is an extremely efficient Class-D structure, providing typically -18 dBm to +6 dBm to the antenna. It is fed by the VCO's divide-by-two circuit and delivers its TX power to the antenna pin through the combined RX/TX matching circuit.

41.2.4 RFIO

The RX/TX combiner block is a unique feature of the DA1469x. It makes sure that the received power is applied to the LNA with minimum losses towards the RFPA. In TX mode, the LNA poses a minimal load for the RFPA and its input pins are protected from the RFPA. In both modes, the single ended RFIO port is matched to 50 Ω to provide the simplest possible interfacing to the antenna on the printed circuit board.

41.2.5 Biasing

All RF blocks are supplied by on-chip low dropout regulators (LDOs). The bias scheme is programmable and optimized for minimum power consumption.

41.2.6 RF Monitoring

The radio is equipped with a monitoring block, of which the responsibility is to acquire the data provided by the functional RF Units and other various analog resources and the packing of the data in words of 32 bits (when necessary), and to store them in system's memory, to achieve the production test of the corresponding blocks. The data can be the output of the Demodulator (I and Q) and the data provided by the GPADC.

42. Registers

This section contains a detailed view of the DA1469x registers. It is organized as follows:

- An overview table is presented initially, which depicts all register names, addresses and descriptions.
- A detailed bit level description of each register follows.

The register file of the Cortex-M33 and Cortex-M0+ can be found in the following documents, available on the Arm website:

Devices Generic User Guide:

[arm_cortex_m33_dgug_100235_0002_00_en.pdf](#)
[DUI0662B_cortex_m0p_r0p1_dgug.pdf](#)

Technical Reference Manual:

[Cortex_m33_trm_100230_0002_00_en.pdf](#)
[DDI0484C_cortex_m0p_r0p1_trm.pdf](#)

These documents contain the register descriptions for the Nested Vectored Interrupt Controller (NVIC), the System Control Block (SCB) and the System Timer (SysTick).

42.1 AMBA Bus Registers

Table 148: Register map DW

Address	Register	Description
0x30020000	AHB_DMA_PL1_REG	AHB-DMA layer priority level for RFTP (AHB DMA layer only)
0x30020004	AHB_DMA_PL2_REG	AHB-DMA layer priority level for LCD (AHB DMA layer only)
0x30020008	AHB_DMA_PL3_REG	AHB-DMA layer Priority level for GEN-DMA (AHB DMA layer only)
0x3002000C	AHB_DMA_PL4_REG	AHB-DMA layer Priority level for CRYPTO-DMA (AHB DMA layer only)
0x30020048	AHB_DMA_DFLT_MASTER_REG	Default master ID number (AHB DMA layer only)
0x3002004C	AHB_DMA_WTEN_REG	Weighted-Token Arbitration Scheme Enable (AHB DMA layer only)
0x30020050	AHB_DMA_TCL_REG	Master clock refresh period (AHB DMA layer only)
0x30020054	AHB_DMA_CCLM1_REG	USB Master clock tokens (AHB DMA layer only)
0x30020058	AHB_DMA_CCLM2_REG	GenDMA Master clock tokens (AHB DMA layer only)
0x3002005C	AHB_DMA_CCLM3_REG	CRYPTO Master clock tokens (AHB DMA layer only)
0x30020060	AHB_DMA_CCLM4_REG	CRYPTO Master clock tokens (AHB DMA layer only)
0x30020090	AHB_DMA_VERSION_REG	Version ID (AHB DMA layer only)

Table 149: [AHB_DMA_PL1_REG](#) (0x30020000)

Bit	Mode	Symbol	Description	Reset
31:4	R	-	Reserved	0x0
3:0	R/W	AHB_DMA_PL1	Arbitration priority for master RFTP. 0: lowest, 15: highest.	0xF

Table 150: [AHB_DMA_PL2_REG](#) (0x30020004)

Bit	Mode	Symbol	Description	Reset
31:4	R/W	-	Reserved	0x0
3:0	R/W	AHB_DMA_PL2	Arbitration priority for master LCD. 0: lowest, 15: highest.	0xE

Table 151: **AHB_DMA_PL3_REG (0x30020008)**

Bit	Mode	Symbol	Description	Reset
31:4	R	-	Reserved	0x0
3:0	R/W	AHB_DMA_PL3	Arbitration priority for master GEN-DMA. 0: lowest, 15: highest.	0xD

Table 152: **AHB_DMA_PL4_REG (0x3002000C)**

Bit	Mode	Symbol	Description	Reset
31:4	R	-	Reserved	0x0
3:0	R/W	AHB_DMA_PL4	Arbitration priority for master CRYPTO-DMA. 0: lowest, 15: highest.	0xC

Table 153: **AHB_DMA_DFLT_MASTER_REG (0x30020048)**

Bit	Mode	Symbol	Description	Reset
31:4	R	-	Reserved	0x0
3:0	R/W	AHB_DMA_DFLT_MASTER	Default master ID number register. The default master is the master that is granted by the bus when no master has requested ownership. 0: Dummy master 1: RFPT 2: LCD 3: GEN-DMA 3: CRYPTO-DMA	0x0

Table 154: **AHB_DMA_WTEN_REG (0x3002004C)**

Bit	Mode	Symbol	Description	Reset
31:1	R	-	Reserved	0x0
0	R/W	AHB_DMA_WTEN	Weighted-token arbitration scheme enable.	0x0

Table 155: **AHB_DMA_TCL_REG (0x30020050)**

Bit	Mode	Symbol	Description	Reset
31:16	R	-	Reserved	0x0
15:0	R/W	AHB_DMA_TCL	Master clock refresh period, counting clock cycles. An arbitration period is defined over this number of tokens. When a new arbitration period starts, the master counters are reloaded. Recommended value is the sum of the AHB_DMA_CCLMx_REG values plus 2 tokens for each master, i.e. plus 6.	0xFFFF

Table 156: **AHB_DMA_CCLM1_REG (0x30020054)**

Bit	Mode	Symbol	Description	Reset
31:16	R	-	Reserved	0x0

Bit	Mode	Symbol	Description	Reset
15:0	R/W	AHB_DMA_CCLM	Number of tokens (counted in AHB clock cycles) that a master can use on the bus before it has to arbitrate on a bus master with low priority and having tokens. Masters with tokens remaining have priority over masters that have used all of their tokens. User should configure all the token values ensuring that the sum does not exceeds the total allocated number of tokens. If a value of zero is configured, then the bus is deemed to have infinite tokens and will always operate in the upper-tier of arbitration.	0xF

Table 157: [AHB_DMA_CCLM2_REG \(0x30020058\)](#)

Bit	Mode	Symbol	Description	Reset
31:16	R	-	Reserved	0x0
15:0	R/W	AHB_DMA_CCLM	Refer to AHB_DMA_CCLM1_REG	0xF

Table 158: [AHB_DMA_CCLM3_REG \(0x3002005C\)](#)

Bit	Mode	Symbol	Description	Reset
31:16	R	-	Reserved	0x0
15:0	R/W	AHB_DMA_CCLM	AHB_DMA_CCLM1_REG	0xF

Table 159: [AHB_DMA_CCLM4_REG \(0x30020060\)](#)

Bit	Mode	Symbol	Description	Reset
31:16	R	-	Reserved	0x0
15:0	R/W	AHB_DMA_CCLM	AHB_DMA_CCLM1_REG	0xF

Table 160: [AHB_DMA_VERSION_REG \(0x30020090\)](#)

Bit	Mode	Symbol	Description	Reset
31:0	R	AHB_DMA_VERSION		0x323133 2A

42.2 LCD Controller Registers

Table 161: Register map LCDC

Address	Register	Description
0x30030000	LCDC_MODE_REG	Display Mode
0x30030004	LCDC_CLKCTRL_REG	Clock Divider
0x30030008	LCDC_BGCOLOR_REG	Background Color
0x3003000C	LCDC_RESXY_REG	Resolution X,Y
0x30030014	LCDC_FRONTPORCHX Y_REG	Front Porch X and Y

Multi-Core Bluetooth 5.2 SoC Family with System PMU

Address	Register	Description
0x30030018	LCDC_BLANKINGXY_REG	Blanking X and Y
0x3003001C	LCDC_BACKPORCHXY_REG	Back Porch X and Y
0x30030028	LCDC_DBIB_CFG_REG	MIPI Config Register
0x3003002C	LCDC_GPIO_REG	General Purpose IO (2-bits)
0x30030030	LCDC_LAYER0_MODE_REG	Layer0 Mode
0x30030034	LCDC_LAYER0_STARTXY_REG	Layer0 Start XY
0x30030038	LCDC_LAYER0_SIZEXY_REG	Layer0 Size XY
0x3003003C	LCDC_LAYER0_BASEADDR_REG	Layer0 Base Addr
0x30030040	LCDC_LAYER0_STRIDE_REG	Layer0 Stride
0x30030044	LCDC_LAYER0_RESXY_REG	Layer0 Res XY
0x30030090	LCDC_JDI_RESXY_REG	Resolution XY for the JDI parallel I/F
0x30030094	LCDC_JDI_FBX_BLANKING_REG	Horizontal front/back blanking (hck half periods)
0x30030098	LCDC_JDI_FBY_BLANKING_REG	Vertical front/back blanking (vck half periods)
0x3003009C	LCDC_JDI_HCK_WIDTH_REG	HCK high/low width
0x300300A0	LCDC_JDI_XRST_WIDTH_REG	XRST width
0x300300A4	LCDC_JDI_VST_DELAY_REG	XRST-to-VST delay
0x300300A8	LCDC_JDI_VST_WIDTH_REG	VST width
0x300300AC	LCDC_JDI_VCK_DELAY_REG	XRST-to-VCK delay
0x300300B0	LCDC_JDI_HST_DELAY_REG	VCK-to-HST delay
0x300300B4	LCDC_JDI_HST_WIDTH_REG	HST width
0x300300B8	LCDC_JDI_ENB_START_HLINE_REG	ENB start horizontal line
0x300300BC	LCDC_JDI_ENB_END_HLINE_REG	ENB end horizontal line
0x300300C0	LCDC_JDI_ENB_START_CLK_REG	ENB start delay
0x300300C4	LCDC_JDI_ENB_WIDTH_CLK_REG	ENB width
0x300300E8	LCDC_DBIB_CMD_REG	MIPI DBIB Command Register
0x300300F4	LCDC_IDREG_REG	Identification Register

Address	Register	Description
0x300300F8	LCDC_INTERRUPT_REG	Interrupt Register
0x300300FC	LCDC_STATUS_REG	Status Register
0x30030184	LCDC_CRC_REG	CRC check
0x30030188	LCDC_LAYER0_OFFSET_X_REG	Layer0 OffsetX and DMA prefetch

Table 162: LCDC_MODE_REG (0x30030000)

Bit	Mode	Symbol	Description	Reset
31	R/W	LCDC_MODE_EN	Mode register. 0 : disable 1 : enable	0x0
30:29	R/W	-	Reserved	0x0
28	R/W	LCDC_VSYNC_POL	VSYNC polarity. 0: positive 1: negative	0x0
27	R/W	LCDC_HSYNC_POL	HSYNC polarity. 0: positive 1: negative	0x0
26	R/W	LCDC_DE_POL	DE polarity. 0: positive 1: negative	0x0
25:24	R/W	-	Reserved	0x0
23	R/W	LCDC_VSYNC_SCPL	Set VSYNC for a single cycle per line. 0: disable 1: enable	0x0
22	R/W	LCDC_PIXCLKOUT_POL	Pixel clock out polarity. 0: positive 1: negative	0x0
21:20	R/W	-	Reserved	0x0
19	R/W	LCDC_FORCE_BLANK	Forces output to blank. 0: disable 1: enable	0x0
18	R/W	-	Reserved	0x0
17	R/W	LCDC_SFRAME_UPD	Single frame update. 0: disable 1: enable	0x0
16:12	R/W	-	Reserved	0x0
11	R/W	LCDC_PIXCLKOUT_SEL	Selects the pixel out clock for the display. 0: based on the pixel pipeline clock 1: based on the format pipeline clock See also the LCDC_CLKCTRL_REG.	0x0
10:9	R/W	-	Reserved	0x0
8:5	R/W	LCDC_OUT_MODE	Selection of the output mode	0x0

Bit	Mode	Symbol	Description	Reset
			0000: Parallel RGB 1000: JDI MIP All the other values are reserved.	
4	R/W	LCDC_MIPI_OFF	MIPI off. (SPI mode of MIPI standard) 0: disabled 1: enabled	0x0
3	R/W	LCDC_FORM_OFF	Formating off 0: disabled 1: enabled	0x0
2	R/W	-	Reserved	0x0
1	R/W	LCDC_DSCAN	Double horizontal scan 0: disabled 1: enabled	0x0
0	R/W	LCDC_TMODE	Test mode 0: disabled 1: enabled	0x0

Table 163: LCDC_CLKCTRL_REG (0x30030004)

Bit	Mode	Symbol	Description	Reset
31:27	R/W	LCDC_SEC_CLK_DIV	Secondary clock divider that generates the format pipeline clock. Source clock of this divider is the main clock of LCD controller. The period of the generated clock is defined as : (LCDC_SEC_CLK_DIV + 1) x period_of_main_clock.	0x0
26:14	R/W	-	Reserved	0x0
13:8	R/W	LCDC_DMA_HOLD	Hold time before DMA activated.	0x4
7:6	R/W	-	Reserved	0x0
5:0	R/W	LCDC_CLK_DIV	Clock divider that generates the pixel pipeline clock. Source clock of this divider is the format pipeline clock (see also LCDC_SEC_CLK_DIV). The period of the generated clock is defines as : LCDC_CLK_DIV x period_of_format_clk. A zero value gives division by one.	0x1

Table 164: LCDC_BGCOLOR_REG (0x30030008)

Bit	Mode	Symbol	Description	Reset
31:24	R/W	LCDC_BG_RED	Red color used as background.	0x0
23:16	R/W	LCDC_BG_GREEN	Green color used as background.	0x0
15:8	R/W	LCDC_BG_BLUE	Blue color used as background.	0x0
7:0	R/W	LCDC_BG_ALPHA	Alpha color used as background.	0x0

Table 165: LCDC_RESXY_REG (0x3003000C)

Bit	Mode	Symbol	Description	Reset
31:16	R/W	LCDC_RES_X	Resolution X in pixels.	0x0

Bit	Mode	Symbol	Description	Reset
15:0	R/W	LCDC_RES_Y	Resolution Y in pixels.	0x0

Table 166: LCDC_FRONTPORCHXY_REG (0x30030014)

Bit	Mode	Symbol	Description	Reset
31:16	R/W	LCDC_FPORCH_X	Front porch X (lines)	0x0
15:0	R/W	LCDC_FPORCH_Y	Front porch Y (pixel clocks)	0x0

Table 167: LCDC_BLANKINGXY_REG (0x30030018)

Bit	Mode	Symbol	Description	Reset
31:16	R/W	LCDC_BLANKING_X	Blanking period X (VSYNC lines)	0x0
15:0	R/W	LCDC_BLANKING_Y	Blanking period Y (HSYNC pulse length)	0x0

Table 168: LCDC_BACKPORCHXY_REG (0x3003001C)

Bit	Mode	Symbol	Description	Reset
31:16	R/W	LCDC_BPORCH_X	Back porch X (lines)	0x0
15:0	R/W	LCDC_BPORCH_Y	Back porch Y (pixel clocks)	0x0

Table 169: LCDC_DBIB_CFG_REG (0x30030028)

Bit	Mode	Symbol	Description	Reset
31	R/W	LCDC_DBIB_TE_DIS	Disable the sampling of the tearing effect signal, which is provided by the LCD device. 0: the tearing effect signal is sampled 1: the tearing effect signal is not sampled.	0x0
30	R/W	LCDC_DBIB_CSX_FORCE	Forces the DBIB CSX value. When is enabled the DBIB CSX takes the value of the LCDC_DBIB_CSX_FORCE_VAL. 0 : disable 1 : enable	0x0
29	R/W	LCDC_DBIB_CSX_FORCE_VAL	Value of DBIB CSX to be forced, if bit 30 is set. Defines also the active level of the DBIB CSX even if the bit 30 is not set.	0x0
28	R/W	LCDC_DBIB_SPI_PADDING	Data padding : 0 : disable 1 : enable	0x0
27:26	R/W	-	Reserved	0x0
25	R/W	LCDC_DBIB_RESX	DBIB RESX, reset signal for MIPI DBIB display.	0x0
24	R/W	LCDC_DBIB_DMA_EN	Send pixels from DMA to DBIB display. 0 : disable 1 : enable	0x0
23	R/W	LCDC_DBIB_SPI3_EN	Enable SPI3 interface. 0 : disable 1 : enable	0x0

Bit	Mode	Symbol	Description	Reset
22	R/W	LCDC_DBIB_SPI4_EN	Enable SPI4 interface. 0 : disable 1 : enable	0x0
21	R/W	-	Reserved	0x0
20	R/W	LCDC_DBIB_SPI_CP HA	Sets the data phase for the SPI interface	0x0
19	R/W	LCDC_DBIB_SPI_CP OL	Sets the polarity of the clock (SCL)	0x0
18	R/W	LCDC_DBIB_SPI_JDI	Enables the line addressing between the horizontal lines (JDI SPI output format). 0 : disable 1 : enable	0x0
17	R/W	LCDC_DBIB_SPI_HO LD	Enables the command HOLD mode of operation. Commands and data transmissions binding. 0 : disable 1 : enable	0x0
16	R/W	LCDC_DBIB_SPI_INV _ADDR	Enables horizontal line address inversion. 0 : disable 1 : enable	0x0
15	R/W	LCDC_DBIB_INV_DA TA	Data inversion 0 : disable 1 : enable	0x0
14	R/W	LCDC_DBIB_JDI_INV _PIX	MSB-LSB bit selection for JDI parallel interface 0 : disable (MSB - LSB) 1 : enable (LSB -MSB)	0x0
13	R/W	LCDC_DBIB_JDI_SOF T_RST	JDI timing generation soft reset. 0 : disable 1 : enable	0x0
12:5	R/W	-	Reserved	0x0
4:0	R/W	LCDC_DBIB_FMT	Defines the output format and depends of the type of the output interface. For the SPI3/SPI4 are supported the following formats: 0x06 : RGB111-1 {2b00, R(n), G(n), B(n), R(n+1), G(n+1), B(n+1)} 0x07 : RGB111-2 {R(n), G(n), B(n), 1b0, R(n+1), G(n+1), B(n+1), 1b0} 0x08 : RGB111-3 {R(n), G(n), B(n), R(n+1), G(n+1), B(n+1), R(n+2), G(n+2), B(n+2),... } 0x09 : RGB111-4 {D(n), D(n+1), D(n+2),...} 0x10 : RGB332 0x11 : RGB444 0x12 : RGB565 0x13 : RGB666 0x14 : RGB888 For the JDI parallel interface should be used the format : 0x0A : RGB222	0x0

Table 170: **LCDC_GPIO_REG** (0x3003002C)

Bit	Mode	Symbol	Description	Reset
31:2	-	-	Reserved	0x0
1	R/W	LCDC_TE_INV	Applies an inversion on the TE (tearing effect) signal. 0 : the inversion is not applied on the TE signal 1 : the inversion is applied on TE signal	0x0
0	R/W	LCDC_PARIF_SEL	Selection of the parallel interface type that is forwarded to the gpio pins. 0 : JDI interface signals 1 : Clasic parallel interface	0x0

Table 171: **LCDC_LAYER0_MODE_REG** (0x30030030)

Bit	Mode	Symbol	Description	Reset
31	R/W	LCDC_L0_EN	Enable layer. 0 : disable 1 : enable	0x0
30:5	R/W	-	Reserved	0x0
4:0	R/W	LCDC_L0_COLOUR_MODE	Colour Mode: 00001: 16-bit RGBX5551 color format, 00010: 32-bit RGBX8888 color format, 00100: 8-bit RGB332 color format, 00101: 16-bit RGB565 color format, 00110: 32-bit XRGB8888, 00111: L8 Grayscale/Palette format, 01000: L1 Grayscale/Palette format, 01001: L4 Grayscale/Palette format, 01101: ABGR8888, 01110: BGRA8888	0x0

Table 172: **LCDC_LAYER0_STARTXY_REG** (0x30030034)

Bit	Mode	Symbol	Description	Reset
31:16	R/W	LCDC_L0_START_X	Start X (offset pixels)	0x0
15:0	R/W	LCDC_L0_START_Y	Start Y (offset pixels)	0x0

Table 173: **LCDC_LAYER0_SIZEXY_REG** (0x30030038)

Bit	Mode	Symbol	Description	Reset
31:16	R/W	LCDC_L0_SIZE_X	Size X (Size of layer in pixels)	0x0
15:0	R/W	LCDC_L0_SIZE_Y	Size Y (Size of layer in pixels)	0x0

Table 174: **LCDC_LAYER0_BASEADDR_REG** (0x3003003C)

Bit	Mode	Symbol	Description	Reset
31:0	R/W	LCDC_L0_FB_ADDR	Base Address of the frame buffer	0x0

Table 175: LCDC_LAYER0_STRIDE_REG (0x30030040)

Bit	Mode	Symbol	Description	Reset
31:21	R/W	-	Reserved	0x0
20:19	R/W	LCDC_L0_FIFO_THR	Layer dma fifo threshold burst start 00: half fifo (default) 01: 2 burst size 10: 4 burst size 11: 8 burst size	0x0
18:16	R/W	LCDC_L0_BURST_LEN	Layer burst length 000: 16-beats (default) 001: 2-beats 010: 4-beats 011: 8-beats 100: 16-beats	0x0
15:0	R/W	LCDC_L0_STRIDE	Layer Stride (distance from line to line in bytes)	0x0

Table 176: LCDC_LAYER0_RESXY_REG (0x30030044)

Bit	Mode	Symbol	Description	Reset
31:16	R/W	LCDC_L0_RES_X	Resolution X (Resolution of layer in pixels)	0x0
15:0	R/W	LCDC_L0_RES_Y	Resolution Y (Resolution of layer in pixels)	0x0

Table 177: LCDC_JDI_RESXY_REG (0x30030090)

Bit	Mode	Symbol	Description	Reset
31:16	R/W	LCDC_JDI_RES_X	Number of horizontal transfers. Should be equal to the half of the horizontal resolution (in pixels).	0x0
15:0	R/W	LCDC_JDI_RES_Y	Number of vertical transfers. Should be equal to the double of the vertical resolution (in lines).	0x0

Table 178: LCDC_JDI_FBX_BLANKING_REG (0x30030094)

Bit	Mode	Symbol	Description	Reset
31:16	R/W	LCDC_JDI_FXBLANKING	Horizontal front blanking as a number of hck half periods	0x0
15:0	R/W	LCDC_JDI_BXBLANKING	Horizontal back blanking as a number of hck half periods	0x0

Table 179: LCDC_JDI_FBY_BLANKING_REG (0x30030098)

Bit	Mode	Symbol	Description	Reset
31:16	R/W	LCDC_JDI_FYBLANKING	Vertical front blanking as a number of vck half periods	0x0
15:0	R/W	LCDC_JDI_BYBLANKING	Vertical back blanking as a number of vck half periods	0x0

Table 180: LCDC_JDI_HCK_WIDTH_REG (0x3003009C)

Bit	Mode	Symbol	Description	Reset
31:0	R/W	LCDC_JDI_HCK_WIDTH	Number of format pipeline clock cycles that define the half period of the of the HCK (high and low width). The minimum allowed value is 2.	0x0

Table 181: LCDC_JDI_XRST_WIDTH_REG (0x300300A0)

Bit	Mode	Symbol	Description	Reset
31:0	R/W	LCDC_JDI_XRST_WIDTH	Number of format pipeline clock cycles of XRST width	0x0

Table 182: LCDC_JDI_VST_DELAY_REG (0x300300A4)

Bit	Mode	Symbol	Description	Reset
31:0	R/W	LCDC_JDI_VST_DELAY	XRST-to-VST delay in format pipeline clock cycles	0x0

Table 183: LCDC_JDI_VST_WIDTH_REG (0x300300A8)

Bit	Mode	Symbol	Description	Reset
31:0	R/W	LCDC_JDI_VST_WIDTH	VST width in format pipeline clock cycles	0x0

Table 184: LCDC_JDI_VCK_DELAY_REG (0x300300AC)

Bit	Mode	Symbol	Description	Reset
31:0	R/W	LCDC_JDI_VCK_DELAY	XRST-to-VCK delay in format pipeline clock cycles	0x0

Table 185: LCDC_JDI_HST_DELAY_REG (0x300300B0)

Bit	Mode	Symbol	Description	Reset
31:0	R/W	LCDC_JDI_HST_DELAY	VCK-to-HST delay in format pipeline clock cycles	0x0

Table 186: LCDC_JDI_HST_WIDTH_REG (0x300300B4)

Bit	Mode	Symbol	Description	Reset
31:0	R/W	LCDC_JDI_HST_WIDTH	HST width in format pipeline clock cycles	0x0

Table 187: LCDC_JDI_ENB_START_HLINE_REG (0x300300B8)

Bit	Mode	Symbol	Description	Reset
31:0	R/W	LCDC_JDI_ENB_START_HLINE	The number of the first horizontal line where the ENB signal is asserted	0x0

Table 188: **LCDC_JDI_ENB_END_HLINE_REG (0x300300BC)**

Bit	Mode	Symbol	Description	Reset
31:0	R/W	LCDC_JDI_ENB_END_HLINE	The number of the last horizontal line where the ENB signal is asserted	0x0

Table 189: **LCDC_JDI_ENB_START_CLK_REG (0x300300C0)**

Bit	Mode	Symbol	Description	Reset
31:0	R/W	LCDC_JDI_ENB_START_CLK	Defines the number of the HCK half periods that should take place after a transition in the VCK and before to be enabled of the ENB.	0x0

Table 190: **LCDC_JDI_ENB_WIDTH_CLK_REG (0x300300C4)**

Bit	Mode	Symbol	Description	Reset
31:0	R/W	LCDC_JDI_ENB_WIDTH_CLK	ENB (high) width in HCK half periods	0x0

Table 191: **LCDC_DBIB_CMD_REG (0x300300E8)**

Bit	Mode	Symbol	Description	Reset
31	R/W	-	Reserved	0x0
30	R/W	LCDC_DBIB_CMD_SEND	Send command to the DBI interface	0x0
29	R/W	-	Reserved	0x0
28	R/W	-	Reserved	0x0
27	R/W	LCDC_DBIB_CMD_STORE	This bit has meaning only when LCDC_DBIB_CFG_REG[LCDC_DBIB_SPI_JDI] = 1. When is enabled, stores the LCDC_DBIB_CMD_VAL to the register that keeps the Y position.	0x0
26:16	R/W	-	Reserved	0x0
15:0	R/W	LCDC_DBIB_CMD_VAL	Data to send to the DBI interface	0x0

Table 192: **LCDC_IDREG_REG (0x300300F4)**

Bit	Mode	Symbol	Description	Reset
31:0	R	LCDC_ID	Identification register	0x87452365

Table 193: **LCDC_INTERRUPT_REG (0x300300F8)**

Bit	Mode	Symbol	Description	Reset
31	R/W	LCDC_IRQ_TRIGGER_SEL	IRQ trigger control 0: Level triggering 1: Edge triggering In the case of the level triggering, the request remains active in the LCDC until to be cleared. The request can be cleared by performing a write access in the	0x0

Bit	Mode	Symbol	Description	Reset
			LCDC_INTERRUPT_REG. This is not required in the case of the edge triggering.	
30:6	-	-	Reserved	0x0
5	R/W	LCDC_FRAME_END_I RQ_EN	Continuous mode: frame end. Single mode: frame end or idle.	0x0
4	R/W	-	Reserved	0x0
3	R/W	LCDC_TE_IRQ_EN	TE interrupt enable. See also the configuration bit LCDC_DBIB_CFG_REG[LCDC_DBIB_TE_DIS]	0x0
2	R/W	-	Reserved	0x0
1	R/W	LCDC_HSYNC_IRQ_E N	HSYNC interrupt enabled	0x0
0	R/W	LCDC_VSYNC_IRQ_E N	VSYNC or TE interrupt enabled. See also the configuration bit LCDC_DBIB_CFG_REG[LCDC_DBIB_TE_DIS] for the TE signal.	0x1

Table 194: LCDC_STATUS_REG (0x300300FC)

Bit	Mode	Symbol	Description	Reset
31:16	-	-	Reserved	0x0
15	R	LCDC_JDI_TIM_SW_ RST	JDI timing generation soft reset (active high)	0x0
14	R	LCDC_FRAME_STAR T	Frame start (active high)	0x0
13	R	LCDC_FRAME_END	Frame end (active high)	0x0
12	R	LCDC_DBIB_CMD_PE NDING	Transferring of command in progress. 0: idle 1: in progress	0x0
11	R	LCDC_DBIB_CMD_FI FO_FULL	Command fifo full indication. 0: is not full 1: is full	0x0
10	R	LCDC_DBIB_CMD_FI FO_EMPTY_N	Command fifo empty indication (negative) 0: the fifo is empty 1: the fifo is not empty	0x0
9	-	-	Reserved	0x0
8	R	LCDC_DBIB_TE	The DBIB tearing effect signal	0x0
7	R	LCDC_STICKY_UNDE RFLOW	Sticky underflow (clear with write in the LCDC_INTERRUPT_REG) 0: There is no underflow 1: Underflow has been detected. Remains high until to be cleared by performing a write access on the register LCDC_INTERRUPT_REG.	0x0
6	R	LCDC_UNDERFLOW	Underflow on the current transfer. 0: There is no underflow 1: Underflow has been detected.	0x0
5	R	LCDC_LAST_ROW	Last row (Last row is currently displayed)	0x0
4	R	LCDC_STAT_CS SYNC	CSYNC signal level	0x0

Bit	Mode	Symbol	Description	Reset
3	R	LCDC_STAT_VSYNC	VSYNC signal level	0x0
2	R	LCDC_STAT_HSYNC	HSYNC signal level	0x0
1	R	LCDC_FRAMEGEN_B USY	The frame generator is busy (active high).	0x0
0	R	LCDC_STAT_ACTIVE	Active (When not in vertical blanking)	0x0

Table 195: LCDC_CRC_REG (0x30030184)

Bit	Mode	Symbol	Description	Reset
31:0	R	LCDC_CRC	CRC check.	0x0

Table 196: LCDC_LAYER0_OFFSETX_REG (0x30030188)

Bit	Mode	Symbol	Description	Reset
31:16	R/W	LCDC_L0_DMA_PRE FETCH	DMA fifo prefetch level (range: 0-4) 0x0 : Prefetch mechanism is disabled 0x1 : Prefetch at least 44 bytes 0x2 : Prefetch at least 84 bytes 0x3 : Prefetch at least 116 bytes 0x4 : Prefetch at least 108 bytes Any other value : Reserved	0x0
15:0	R/W	LCDC_L0_OFFSETX	Offset X (negative) of X start pixel (range [n-1,0], n : pixels /8)	0x0

42.3 LRA/ERM Registers

Table 197: Register map LRA

Address	Register	Description
0x50030A00	LRA_CTRL1_REG	General Purpose LRA Control Register
0x50030A04	LRA_CTRL2_REG	General Purpose LRA Control Register
0x50030A08	LRA_CTRL3_REG	General Purpose LRA Control Register
0x50030A0C	LRA_FLT_SMP1_REG	LRA Sample Register
0x50030A10	LRA_FLT_SMP2_REG	LRA Sample Register
0x50030A14	LRA_FLT_SMP3_REG	LRA Sample Register
0x50030A18	LRA_FLT_SMP4_REG	LRA Sample Register
0x50030A1C	LRA_FLT_SMP5_REG	LRA Sample Register
0x50030A20	LRA_FLT_SMP6_REG	LRA Sample Register
0x50030A24	LRA_FLT_SMP7_REG	LRA Sample Register
0x50030A28	LRA_FLT_SMP8_REG	LRA Sample Register
0x50030A2C	LRA_FLT_COEF1_REG	LRA Filter Coefficient Register
0x50030A30	LRA_FLT_COEF2_REG	LRA Filter Coefficient Register
0x50030A34	LRA_FLT_COEF3_REG	LRA Filter Coefficient Register

Address	Register	Description
0x50030A38	LRA_BRD_LS_REG	LRA Bridge Register
0x50030A3C	LRA_BRD_HS_REG	LRA Bridge Register
0x50030A40	LRA_BRD_STAT_REG	LRA Bridge Status Register
0x50030A44	LRA_ADC_CTRL1_REG	General Purpose ADC Control Register
0x50030A50	LRA_ADC_RESULT_REG	General Purpose ADC Result Register
0x50030A54	LRA_LDO_REG	LRA LDO Register
0x50030A58	LRA_DFT_REG	LRA test Register

Table 198: [LRA_CTRL1_REG](#) (0x50030A00)

Bit	Mode	Symbol	Description	Reset
31:28	-	-	Reserved	0x0
27:24	R	SMP_IDX	Current bin index (0-15). Check if equal to IRQ_IDX before and/or after updating HALF_PERIOD with ISR.	0x0
23:19	-	-	Reserved	0x0
18	R/W	IRQ_SCP_EVENT_EN	0 = interrupt scp event disabled 1 = interrupt scp event enabled	0x0
17	R/W	IRQ_ADC_EN	0 = interrupt adc disabled 1 = interrupt adc enabled	0x0
16	R/W	IRQ_CTRL_EN	0 = interrupt controller disabled 1 = interrupt controller enabled	0x0
15:12	R/W	IRQ_IDX	At which sample index an IRQ will be generated (0-15). When IRQ_IDX < 8, IRQs are generated at both half cycles (IRQ_IDX and IRQ_IDX+8), otherwise only in the second half cycle.	0x7
11:8	R/W	IRQ_DIV	Divider value of the interrupt request. Number of LRA/ERM periods, between successive IRQs. 0,1=every (half) cycle, depending on IRQ_IDX; 2=every second cycle, IRQ at the end of first or both half cycles (based on IRQ_IDX), etc.	0x1
7:6	R/W	SMP_SEL	Select which samples to store for the resonance control algorithm. 0=Sense voltage after down-sampling 1=Error voltage (after subtraction of VREF and down-sampled sense voltage input) 2=Duty cycle signal after loop-filter 3=Duty cycle signal after summation with DREF	0x3
5	R/W	PULLDOWN_EN	LXP and LXN node pull down enable, when SC_EVENT=0 && LOOP_EN=0	0x0
4	R/W	LOOP_EN	0=disable loop 1=enable loop	0x0
3	R/W	LDO_EN	0=LRA LDO disabled 1=LRA LDO enabled	0x0
2	R/W	ADC_EN	0=LRA ADC disabled 1=LRA ADC enabled	0x0
1	R/W	HBRIDGE_EN	0=hbridge disabled	0x0

Bit	Mode	Symbol	Description	Reset
			1=hbridge enabled	
0	R/W	LRA_EN	0=lra controller disabled 1=lra controller enabled	0x0

Table 199: LRA_CTRL2_REG (0x50030A04)

Bit	Mode	Symbol	Description	Reset
31:16	R/W	HALF_PERIOD	Half of the LRA period, in units of 4 μ s (= 125 kHz divided by the resonant frequency of the LRA).	0x271
15:6	-	-	Reserved	0x0
5	R/W	AUTO_MODE	Automatic frequency control (0=disabled;, 1=enabled, not yet implemented)	0x0
4	R/W	SMP_MODE	Sampling mode for data aiding automatic resonance control (0=averaging, 1=last sample)	0x0
3	R/W	POLARITY	Polarity of the square wave (0=normal; 1=inverted); Use for rapid stop.	0x0
2	R/W	FLT_IN_SEL	0 = normal operation 1 = ADC output overruled by register field MAN_FLT_IN	0x0
1:0	R/W	PWM_MODE	PWM pulse placement: 0=middle, 1=left, 2=right, 3=alternate	0x0

Table 200: LRA_CTRL3_REG (0x50030A08)

Bit	Mode	Symbol	Description	Reset
31:16	R/W	VREF	Voltage reference for haptic feedback driver (1 bit sign + 7 bits integer + 8 bits fractional. (range -128 ... +127.99). The voltage is computed based on the desired reference current (IREF) that flows into the haptic device. $VREF = IREF \times TRIM_GAIN \times AGC_GAIN \times 128 / 2.4$, with IREF in Amperes, TRIM_GAIN = 6, 8 (default), 10 or 12 as defined in LRA_BRD_HS_REG, ADC_GAIN is the normalized gain of the ADC (i.e. $ADC_GAIN = GP_ADC_VALUE \times 300 \text{ mA} / [I_{LRA} \times 128]$).	0x0
15:0	R/W	DREF	Duty cycle reference, start value from which the current control loop settles (1 sign bit, 7 integer bits, 8 fractional bits, -128 ... +127.99). Valid settings 5% through 95% (0x0666 - 0x799A).	0x4000

Table 201: LRA_FLT_SMP1_REG (0x50030A0C)

Bit	Mode	Symbol	Description	Reset
31:16	R	LRA_SMP_2	Second sample in first half-cycle used for resonance control algorithm.	0x0
15:0	R	LRA_SMP_1	First sample in first half-cycle used for resonance control algorithm.	0x0

Table 202: LRA_FLT_SMP2_REG (0x50030A10)

Bit	Mode	Symbol	Description	Reset
31:16	R	LRA_SMP_4	Fourth sample in first half-cycle used for resonance control algorithm.	0x0
15:0	R	LRA_SMP_3	Third sample in first half-cycle used for resonance control algorithm.	0x0

Table 203: LRA_FLT_SMP3_REG (0x50030A14)

Bit	Mode	Symbol	Description	Reset
31:16	R	LRA_SMP_6	Sixth sample in first half-cycle used for resonance control algorithm.	0x0
15:0	R	LRA_SMP_5	Fifth sample in first half-cycle used for resonance control algorithm.	0x0

Table 204: LRA_FLT_SMP4_REG (0x50030A18)

Bit	Mode	Symbol	Description	Reset
31:16	R	LRA_SMP_8	Eighth sample in first half-cycle used for resonance control algorithm.	0x0
15:0	R	LRA_SMP_7	Seventh sample in first half-cycle used for resonance control algorithm.	0x0

Table 205: LRA_FLT_SMP5_REG (0x50030A1C)

Bit	Mode	Symbol	Description	Reset
31:16	R	LRA_SMP_10	Second sample in second half-cycle used for resonance control algorithm.	0x0
15:0	R	LRA_SMP_9	First sample in second half-cycle used for resonance control algorithm.	0x0

Table 206: LRA_FLT_SMP6_REG (0x50030A20)

Bit	Mode	Symbol	Description	Reset
31:16	R	LRA_SMP_12	Fourth sample in second half-cycle used for resonance control algorithm.	0x0
15:0	R	LRA_SMP_11	Third sample in second half-cycle used for resonance control algorithm.	0x0

Table 207: LRA_FLT_SMP7_REG (0x50030A24)

Bit	Mode	Symbol	Description	Reset
31:16	R	LRA_SMP_14	Sixth sample in second half-cycle used for resonance control algorithm.	0x0
15:0	R	LRA_SMP_13	Fifth sample in second half-cycle used for resonance control algorithm.	0x0

Table 208: LRA_FLT_SMP8_REG (0x50030A28)

Bit	Mode	Symbol	Description	Reset
31:16	R	LRA_SMP_16	Eighth sample in second half-cycle used for resonance control algorithm.	0x0
15:0	R	LRA_SMP_15	Seventh sample in second half-cycle used for resonance control algorithm.	0x0

Table 209: LRA_FLT_COEF1_REG (0x50030A2C)

Bit	Mode	Symbol	Description	Reset
31:16	R/W	FLT_COEF_01	Loop filter state-space coefficient a12 (1 sign bit, 1 integer bit, 14 fractional bits, range -2.000 .. +1.999).	0x19A
15:0	R/W	FLT_COEF_00	Loop filter state-space coefficient a11 (1 sign bit, 1 integer bit, 14 fractional bits, range -2.000 .. +1.999).	0xE66

Table 210: LRA_FLT_COEF2_REG (0x50030A30)

Bit	Mode	Symbol	Description	Reset
31:16	R/W	FLT_COEF_10	Loop filter state-space coefficient a21 (1 sign bit, 1 integer bit, 14 fractional bits, range -2.000 .. +1.999).	0xE66
15:0	R/W	FLT_COEF_02	Loop filter state-space coefficient b1 (1 sign bit, 1 integer bit, 14 fractional bits, range -2.000 .. +1.999). Note: For correct intended loop gain, modify the intended value of b1 to b1/ADC_GAIN, where ADC_GAIN is the normalized gain of the ADC (i.e. $ADC_GAIN = GP_ADC_VALUE \times 300 \text{ mA} / [I_{LRA} \times 128]$).	0xF3E

Table 211: LRA_FLT_COEF3_REG (0x50030A34)

Bit	Mode	Symbol	Description	Reset
31:16	R/W	FLT_COEF_12	Loop filter state-space coefficient b2 (1 sign bit, 1 integer bit, 14 fractional bits, range -2.000 .. +1.999). Note: For correct intended loop gain, modify the intended value of b1 to b1/ADC_GAIN, where ADC_GAIN is the normalized gain of the ADC (i.e. $ADC_GAIN = GP_ADC_VALUE \times 300 \text{ mA} / [I_{LRA} \times 128]$).	0x16CE
15:0	R/W	FLT_COEF_11	Loop filter state-space coefficient a22 (1 sign bit, 1 integer bit, 14 fractional bits, range -2.000 .. +1.999).	0x19A

Table 212: LRA_BRD_LS_REG (0x50030A38)

Bit	Mode	Symbol	Description	Reset
14	-	-	Reserved	0x0
11:8	R/W	SCP_LS_TRIM_N	LSN short-circuit protection limit trimming	0x0
7:4	R/W	SCP_LS_TRIM_P	LSP short-circuit protection limit trimming	0x0
3	R/W	SCP_LS_EN	LS short-circuit protection enable	0x0
2:1	R/W	ERC_LS_TRIM	LS edge-rate control trimming. High-to-Low switching slewing: 00: 25 MV/s	0x0

Bit	Mode	Symbol	Description	Reset
			01: 50 MV/s 10: 75 MV/s 11: 100 MV/s	
0	R/W	ERC_LS_EN	LS edge-rate control enable	0x0

Table 213: LRA_BRD_HS_REG (0x50030A3C)

Bit	Mode	Symbol	Description	Reset
31:15	-	-	Reserved	0x0
14:11	R/W	TRIM_GAIN	Current-sensing amplifier gain settings: 0001: x6 0010: x8 0100: x10 1000: x12	0x0
10:8	R/W	HSGND_TRIM	HS gnd trim, default at 100 000: 2.2V and 111:3.6V with 0.2V per step	0x0
7:4	R/W	SCP_HS_TRIM	HS short-circuit protection limit trimming	0x0
3	R/W	SCP_HS_EN	HS short-circuit protection enable	0x0
2:1	R/W	ERC_HS_TRIM	HS edge-rate control trimming. Lowto-High switching slewing: 00: 25 MV/s 01: 50 MV/s 10: 75 MV/s 11: 100 MV/s	0x0
0	R/W	ERC_HS_EN	HS edge-rate control enable	0x0

Table 214: LRA_BRD_STAT_REG (0x50030A40)

Bit	Mode	Symbol	Description	Reset
31:14	-	-	Reserved	0x0
13	R	SCP_HS_OUT	HS short circuit comparator output	0x0
12	R	SCP_LS_COMP_OUT_N	LSN short circuit comparator output	0x0
11	R	SCP_LS_COMP_OUT_P	LSP short circuit comparator output	0x0
10	R	SC_EVENT_LS	1: LS short-circuit event detected 0: no LS short-circuit event detected	0x0
9	R	SC_EVENT_HS	1: HS short-circuit event detected 0: no HS short-circuit event detected	0x0
8	R	LOOP_STAT	1: Loop saturation detected 0: Loop not saturated	0x0
7	R	LSN_ON	LSN control status	0x0
6	R	LSP_ON	LSP control status	0x0
5	R	HSN_ON	HSN control status	0x0
4	R	HSP_ON	HSP control status	0x0

Bit	Mode	Symbol	Description	Reset
3	R	LSN_STAT	LSN power FET gate actual status	0x0
2	R	LSP_STAT	LSP power FET gate actual status	0x0
1	R	HSN_STAT	HSN power FET gate actual status	0x0
0	R	HSP_STAT	HSP power FET gate actual status	0x0

Table 215: LRA_ADC_CTRL1_REG (0x50030A44)

Bit	Mode	Symbol	Description	Reset
31	R	LRA_ADC_BUSY	0:ADC conversion ready. 1:ADC conversion in progress.	0x0
30:17	-	-	Reserved	0x0
16:9	R/W	LRA_ADC_OFFSET	ADC offset compensation value. Signed value with 3 fractional bits. -16 (0x80) to +15.875 (0x7F) in intervals of 0.125 (0x01). Note: ADC gain error must be compensated in the calculation of VREF.	0x0
8	R/W	LRA_ADC_TEST_PAR AM	Select which inputs will be enabled on the ADC. 0,1 = normal inputs (i.e. both I and Q inputs connected to LRA-current-sense voltage source) 2 = I channel connected to the analog input testbus on PORTS P14 and P15, Q channel is muted. 3 =Q channel connected to the analog input testbus on PORTS P14 and P15, I channel is muted. Note: The LRA_ADC_CTRL1_REG[ADC_MUTE] field takes precedence over this test functionality.	0x0
7	R/W	LRA_ADC_TEST_IN_ SEL	Select analog testbus on ADC input.	0x0
6:3	R/W	LRA_ADC_FREQ	ADC clock divider	0x4
2	R/W	LRA_ADC_SIGN	Change polarity of ADC input	0x0
1	R/W	LRA_ADC_MUTE	0: Normal operation 1: Short the inputs of the ADC (used for DC offset cal)	0x0
0	R0/W	LRA_ADC_START	If a 1 is written the ADC conversion will start	0x0

Table 216: LRA_ADC_RESULT_REG (0x50030A50)

Bit	Mode	Symbol	Description	Reset
31:16	R/W	MAN_FLT_IN	Manual value to replace the ADC output. Select its use by FLT_IN_SEL.	0x0
15:0	R	GP_ADC_VAL	Returns the 10 up to 16 bits linear value of the last AD conversion as a signed value. The most significant 11 bits are always valid, the lower 5 bits are only valid in case oversampling has been applied. Two samples results in one extra bit and 32 samples results in 5 extra bits. In the context of the LRA constant current or constant duty cycle control systems, the (non-oversampled) value is interpreted as a signed value with 7 integer bits and 3 fractional bits: -128.000 (0x8000) to +127.875 (0x7FE0) in steps of 0.125 (0x0010).	0x4000

Bit	Mode	Symbol	Description	Reset
			Note that the measured values in this context are always positive.	

Table 217: LRA_LDO_REG (0x50030A54)

Bit	Mode	Symbol	Description	Reset
31	R	LDO_OK	0: LDO not yet ok 1: LDO voltage is ready	0x0
1	R/W	LDO_TST	When set to 1, LDO output is connected to the testbus through a test switch	0x0
0	R/W	LDO_VREF_HOLD	0: Indicates that the reference input is tracked, 1: Indicates that the reference input is sampled	0x0

Table 218: LRA_DFT_REG (0x50030A58)

Bit	Mode	Symbol	Description	Reset
31:29	R/W	SPARE	spare registers bits , currently not used	0x0
28	R/W	SWM_SEL	0=use SWM from controller 1=use SWM_MAN	0x0
27	R/W	SWM_MAN	swm manual	0x0
26	R/W	PWM_SEL	0=use PWM from controller 1=use PWM_MAN	0x0
25	R/W	PWM_MAN	pwm manual	0x0
24:23	R/W	TIMER_TRIM	20ns unit delay cell trimming bits	0x0
22:21	R/W	TIMER_SCALE_TRIM	Selection of delay of MAG and DEMAG signal: 00: 60ns 01: 80ns 10: 100ns 11: 120ns	0x0
20	R/W	DFT_SEL	not used	0x0
19	R/W	DFT_FORCE_HSPN	Force HSP and HSN power FETs on: 0: not activated 1: HSP and HSN are forced on	0x0
18	R/W	DFT_EN_TIMER	Enable for the timer trimming	0x0
17:16	R/W	DFT_STALL	Force state machine in a certain state: 00: No test 01: High-Z 10: Mag 11: Demag	0x0
15:0	R/W	DFT_CTRL	Selection of test bus connection	0x0

42.4 Memory Controller Registers

Table 219: Register map MEMCTRL

Address	Register	Description
0x50050004	MEM_PRIO_REG	Priority Control Register
0x50050008	MEM_STALL_REG	Maximum Stall cycles Control Register
0x5005000C	MEM_STATUS_REG	Memory Arbiter Status Register
0x50050010	MEM_STATUS2_REG	RAM cells Status Register
0x50050020	CMI_CODE_BASE_REG	CMAC code Base Address Register
0x50050024	CMI_DATA_BASE_REG	CMAC data Base Address Register
0x50050028	CMI_SHARED_BASE_REG	CMAC shared data Base Address Register
0x5005002C	CMI_END_REG	CMAC end Address Register
0x50050030	SNC_BASE_REG	Sensor Node Controller Base Address Register
0x50050074	BUSY_SET_REG	BSR Set Register
0x50050078	BUSY_RESET_REG	BSR Reset Register
0x5005007C	BUSY_STAT_REG	BSR Status Register

Table 220: MEM_PRIO_REG (0x50050004)

Bit	Mode	Symbol	Description	Reset
5:4	R/W	AHB_PRIO	Priority for the AHB interface. 00: low priority (default) 01: mid priority 1x: high priority	0x0
3:2	R/W	AHB2_PRIO	Priority for the AHB2 interface. 00: low priority (default) 01: mid priority 1x: high priority	0x0
1:0	R/W	SNC_PRIO	Priority for the SNC interface. 00: low priority (default) 01: mid priority 1x: high priority	0x0

Table 221: MEM_STALL_REG (0x50050008)

Bit	Mode	Symbol	Description	Reset
11:8	R/W	AHB_MAX_STALL	Maximum allowed number of stall cycles for the AHB interface. If exceeded, the interface will get top priority (above high priority). Valid for a single access so the next access (of a burst) might end up in the queue for the same number of wait cycles. 0: don't use, not feasible and can block other interfaces 1: max 1 stall cycle 15: max 15 stall cycles	0xF
7:4	R/W	AHB2_MAX_STALL	Maximum allowed number of stall cycles for the AHB2 interface. If exceeded, the interface will get top priority (above high priority). Valid for a single access so the next access (of a burst) might end up in the queue for the same number of wait cycles.	0xF

Bit	Mode	Symbol	Description	Reset
			0: don't use, not feasible and can block other interfaces 1: max 1 stall cycle 15: max 15 stall cycles	
3:0	R/W	SNC_MAX_STALL	Maximum allowed number of stall cycles for the SNC interface. If exceeded, the interface will get top priority (above high priority). Valid for a single access so the next access (of a burst) might end up in the que for the same number of wait cycles. 0: don't use, not feasible and can block other interfaces 1: max 1 stall cycle 15: max 15 stall cycles	0xF

Table 222: MEM_STATUS_REG (0x5005000C)

Bit	Mode	Symbol	Description	Reset
13	W	CMI_CLEAR_READY	Writing a '1' clears CMI_NOT_READY bit.	0x0
12	R	CMI_NOT_READY	0: Normal operation 1: CMI access performed which couldn't be handled right away (interface doesn't allow wait cycles)	0x0
11:8	R	AHB2_WR_BUFF_CNT	The maximum number of arbiter clock cycles that an AHB2 access has been buffered.	0x0
7:4	R	AHB_WR_BUFF_CNT	The maximum number of arbiter clock cycles that an AHB access has been buffered.	0x0
3	W	AHB2_CLR_WR_BUFFER	Writing a '1' clears AHB2_WR_BUFF_CNT.	0x0
2	W	AHB_CLR_WR_BUFFER	Writing a '1' clears AHB_WR_BUFF_CNT.	0x0
1	R	AHB2_WRITE_BUFFER	0: No AHB2 write access is buffered. 1: Currently a single AHB2 write access is buffered in the arbiter.	0x0
0	R	AHB_WRITE_BUFFER	0: No AHB write access is buffered. 1: Currently a single AHB write access is buffered in the arbiter.	0x0

Table 223: MEM_STATUS2_REG (0x50050010)

Bit	Mode	Symbol	Description	Reset
7	RW1C	RAM8_OFF_BUT_ACCESS	Reading a '1' indicates RAM8 was off but still access was performed. Writing a '1' will clear the status back to '0'.	0x0
6	RW1C	RAM7_OFF_BUT_ACCESS	Reading a '1' indicates RAM7 was off but still access was performed. Writing a '1' will clear the status back to '0'.	0x0
5	RW1C	RAM6_OFF_BUT_ACCESS	Reading a '1' indicates RAM6 was off but still access was performed. Writing a '1' will clear the status back to '0'.	0x0
4	RW1C	RAM5_OFF_BUT_ACCESS	Reading a '1' indicates RAM5 was off but still access was performed. Writing a '1' will clear the status back to '0'.	0x0

Bit	Mode	Symbol	Description	Reset
3	RW1C	RAM4_OFF_BUT_ACCESS	Reading a '1' indicates RAM4 was off but still access was performed. Writing a '1' will clear the status back to '0'.	0x0
2	RW1C	RAM3_OFF_BUT_ACCESS	Reading a '1' indicates RAM3 was off but still access was performed. Writing a '1' will clear the status back to '0'.	0x0
1	RW1C	RAM2_OFF_BUT_ACCESS	Reading a '1' indicates RAM2 was off but still access was performed. Writing a '1' will clear the status back to '0'.	0x0
0	RW1C	RAM1_OFF_BUT_ACCESS	Reading a '1' indicates RAM1 was off but still access was performed. Writing a '1' will clear the status back to '0'.	0x0

Table 224: CMI_CODE_BASE_REG (0x50050020)

Bit	Mode	Symbol	Description	Reset
18:10	R/W	CMI_CODE_BASE_ADDR	Base address for CMAC code with steps of 1 kB. 0x001: 1 kB base address 0x010: 16 kB base address 0x100: 256 kB base address	0x0
9:0	R	-	Reserved	0x0

Table 225: CMI_DATA_BASE_REG (0x50050024)

Bit	Mode	Symbol	Description	Reset
18:2	R/W	CMI_DATA_BASE_ADDR	Base address for CMAC data with steps of 4 bytes. 0x00001: 4 byte base address 0x00010: 64 byte base address 0x00100: 1 kB base address 0x01000: 16 kB base address 0x10000: 256 kB base address	0x0
1:0	R	-	Reserved	0x0

Table 226: CMI_SHARED_BASE_REG (0x50050028)

Bit	Mode	Symbol	Description	Reset
18:10	R/W	CMI_SHARED_BASE_ADDR	Base address for CMAC shared data with steps of 1 kB. 0x001: 1 kB base address 0x010: 16 kB base address 0x100: 256 kB base address	0x0
9:0	R	-	Reserved	0x0

Table 227: CMI_END_REG (0x5005002C)

Bit	Mode	Symbol	Description	Reset
18:10	R/W	CMI_END_ADDR	End address for CMAC code and data accesses with steps of 1 kB.	0x1FF

Bit	Mode	Symbol	Description	Reset
			0x000: accesses up to 1kB are allowed 0x001: accesses up to 2kB are allowed 0x01F: accesses up to 32kB are allowed 0x1FF: accesses up to 512kB are allowed	
9:0	R	-	Reserved	0x3FF

Table 228: **SNC_BASE_REG (0x50050030)**

Bit	Mode	Symbol	Description	Reset
18:2	R/W	SNC_BASE_ADDRES S	Base address for SNC interface with steps of 4 bytes. 0x00001: 4 byte base address 0x00010: 64 byte base address 0x00100: 1 kB base address 0x01000: 16 kB base address 0x10000: 256 kB base address	0x0
1:0	R	-	Reserved	0x0

Table 229: **BUSY_SET_REG (0x50050074)**

Bit	Mode	Symbol	Description	Reset
31:30	WS	BUSY_SPARE	Writing a non-zero value to this field sets the corresponding BUSY bit, but only if it was not claimed (BUSY=0). Reading returns 0 to allow read/modify/write to the register.	0x0
29:28	WS	BUSY_MOTOR	Writing a non-zero value to this field sets the corresponding BUSY bit, but only if it was not claimed (BUSY=0). Reading returns 0 to allow read/modify/write to the register.	0x0
27:26	WS	BUSY_TIMER2	Writing a non-zero value to this field sets the corresponding BUSY bit, but only if it was not claimed (BUSY=0). Reading returns 0 to allow read/modify/write to the register.	0x0
25:24	WS	BUSY_TIMER	Writing a non-zero value to this field sets the corresponding BUSY bit, but only if it was not claimed (BUSY=0). Reading returns 0 to allow read/modify/write to the register.	0x0
23:22	WS	BUSY_UART3	Writing a non-zero value to this field sets the corresponding BUSY bit, but only if it was not claimed (BUSY=0). Reading returns 0 to allow read/modify/write to the register.	0x0
21:20	WS	BUSY_GPADC	Writing a non-zero value to this field sets the corresponding BUSY bit, but only if it was not claimed (BUSY=0). Reading returns 0 to allow read/modify/write to the register.	0x0

Bit	Mode	Symbol	Description	Reset
19:18	WS	BUSY_PDM	Writing a non-zero value to this field sets the corresponding BUSY bit, but only if it was not claimed (BUSY=0). Reading returns 0 to allow read/modify/write to the register.	0x0
17:16	WS	BUSY_SRC	Writing a non-zero value to this field sets the corresponding BUSY bit, but only if it was not claimed (BUSY=0). Reading returns 0 to allow read/modify/write to the register.	0x0
15:14	WS	BUSY_PCM	Writing a non-zero value to this field sets the corresponding BUSY bit, but only if it was not claimed (BUSY=0). Reading returns 0 to allow read/modify/write to the register.	0x0
13:12	WS	BUSY_SDADC	Writing a non-zero value to this field sets the corresponding BUSY bit, but only if it was not claimed (BUSY=0). Reading returns 0 to allow read/modify/write to the register.	0x0
11:10	WS	BUSY_I2C2	Writing a non-zero value to this field sets the corresponding BUSY bit, but only if it was not claimed (BUSY=0). Reading returns 0 to allow read/modify/write to the register.	0x0
9:8	WS	BUSY_I2C	Writing a non-zero value to this field sets the corresponding BUSY bit, but only if it was not claimed (BUSY=0). Reading returns 0 to allow read/modify/write to the register.	0x0
7:6	WS	BUSY_SPI2	Writing a non-zero value to this field sets the corresponding BUSY bit, but only if it was not claimed (BUSY=0). Reading returns 0 to allow read/modify/write to the register.	0x0
5:4	WS	BUSY_SPI	Writing a non-zero value to this field sets the corresponding BUSY bit, but only if it was not claimed (BUSY=0). Reading returns 0 to allow read/modify/write to the register.	0x0
3:2	WS	BUSY_UART2	Writing a non-zero value to this field sets the corresponding BUSY bit, but only if it was not claimed (BUSY=0). Reading returns 0 to allow read/modify/write to the register.	0x0
1:0	WS	BUSY_UART	Writing a non-zero value to this field sets the corresponding BUSY bit, but only if it was not claimed (BUSY=0). Reading returns 0 to allow read/modify/write to the register.	0x0

Table 230: **BUSY_RESET_REG (0x50050078)**

Bit	Mode	Symbol	Description	Reset
31:30	RW1C	BUSY_SPARE	Clear the BUSY bitfield, by writing the master code which has claimed to this field Reading returns 0 to allow read/modify/write to the register.	0x0
29:28	RW1C	BUSY_MOTOR	Clear the BUSY bitfield, by writing the master code which has claimed to this field Reading returns 0 to allow read/modify/write to the register.	0x0
27:26	RW1C	BUSY_TIMER2	Clear the BUSY bitfield, by writing the master code which has claimed to this field Reading returns 0 to allow read/modify/write to the register.	0x0
25:24	RW1C	BUSY_TIMER	Clear the BUSY bitfield, by writing the master code which has claimed to this field Reading returns 0 to allow read/modify/write to the register.	0x0
23:22	RW1C	BUSY_UART3	Clear the BUSY bitfield, by writing the master code which has claimed to this field Reading returns 0 to allow read/modify/write to the register.	0x0
21:20	RW1C	BUSY_GPADC	Clear the BUSY bitfield, by writing the master code which has claimed to this field Reading returns 0 to allow read/modify/write to the register.	0x0
19:18	RW1C	BUSY_PDM	Clear the BUSY bitfield, by writing the master code which has claimed to this field Reading returns 0 to allow read/modify/write to the register.	0x0
17:16	RW1C	BUSY_SRC	Clear the BUSY bitfield, by writing the master code which has claimed to this field Reading returns 0 to allow read/modify/write to the register.	0x0
15:14	RW1C	BUSY_PCM	Clear the BUSY bitfield, by writing the master code which has claimed to this field Reading returns 0 to allow read/modify/write to the register.	0x0
13:12	RW1C	BUSY_SDADC	Clear the BUSY bitfield, by writing the master code which has claimed to this field Reading returns 0 to allow read/modify/write to the register.	0x0
11:10	RW1C	BUSY_I2C2	Clear the BUSY bitfield, by writing the master code which has claimed to this field Reading returns 0 to allow read/modify/write to the register.	0x0
9:8	RW1C	BUSY_I2C	Clear the BUSY bitfield, by writing the master code which has claimed to this field Reading returns 0 to allow read/modify/write to the register.	0x0
7:6	RW1C	BUSY_SPI2	Clear the BUSY bitfield, by writing the master code which has claimed to this field	0x0

Bit	Mode	Symbol	Description	Reset
			Reading returns 0 to allow read/modify/write to the register.	
5:4	RW1C	BUSY_SPI	Clear the BUSY bitfield, by writing the master code which has claimed to this field Reading returns 0 to allow read/modify/write to the register.	0x0
3:2	RW1C	BUSY_UART2	Clear the BUSY bitfield, by writing the master code which has claimed to this field Reading returns 0 to allow read/modify/write to the register.	0x0
1:0	RW1C	BUSY_UART	Clear the BUSY bitfield, by writing the master code which has claimed to this field Reading returns 0 to allow read/modify/write to the register.	0x0

Table 231: **BUSY_STAT_REG (0x5005007C)**

Bit	Mode	Symbol	Description	Reset
31:30	R	BUSY_SPARE	A non-zero value indicates the resource is busy. The value represents which master is using it.	0x0
29:28	R	BUSY_MOTOR	A non-zero value indicates the resource is busy. The value represents which master is using it.	0x0
27:26	R	BUSY_TIMER2	A non-zero value indicates the resource is busy. The value represents which master is using it.	0x0
25:24	R	BUSY_TIMER	A non-zero value indicates the resource is busy. The value represents which master is using it.	0x0
23:22	R	BUSY_UART3	A non-zero value indicates the resource is busy. The value represents which master is using it.	0x0
21:20	R	BUSY_GPADC	A non-zero value indicates the resource is busy. The value represents which master is using it.	0x0
19:18	R	BUSY_PDM	A non-zero value indicates the resource is busy. The value represents which master is using it.	0x0
17:16	R	BUSY_SRC	A non-zero value indicates the resource is busy. The value represents which master is using it.	0x0
15:14	R	BUSY_PCM	A non-zero value indicates the resource is busy. The value represents which master is using it.	0x0
13:12	R	BUSY_SDADC	A non-zero value indicates the resource is busy. The value represents which master is using it.	0x0
11:10	R	BUSY_I2C2	A non-zero value indicates the resource is busy. The value represents which master is using it.	0x0
9:8	R	BUSY_I2C	A non-zero value indicates the resource is busy. The value represents which master is using it.	0x0
7:6	R	BUSY_SPI2	A non-zero value indicates the resource is busy. The value represents which master is using it.	0x0
5:4	R	BUSY_SPI	A non-zero value indicates the resource is busy. The value represents which master is using it.	0x0
3:2	R	BUSY_UART2	A non-zero value indicates the resource is busy. The value represents which master is using it.	0x0

Bit	Mode	Symbol	Description	Reset
1:0	R	BUSY_UART	A non-zero value indicates the resource is busy. The value represents which master is using it.	0x0

42.5 OTP Controller Registers

Table 232: Register map OTPC

Address	Register	Description
0x30070000	OTPC_MODE_REG	Mode register
0x30070004	OTPC_STAT_REG	Status register
0x30070008	OTPC_PADDR_REG	The address of the word that will be programmed, when the PROG mode is used.
0x3007000C	OTPC_PWORD_REG	The 32-bit word that will be programmed, when the PROG mode is used.
0x30070010	OTPC_TIM1_REG	Various timing parameters of the OTP cell.
0x30070014	OTPC_TIM2_REG	Various timing parameters of the OTP cell.

Table 233: OTPC_MODE_REG (0x30070000)

Bit	Mode	Symbol	Description	Reset
31:8	-	-	Reserved	0x0
7:6	R/W	OTPC_MODE_PRG_SEL	Defines the part of the OTP cell that is programmed by the controller during the PROG mode, for each program request that is applied. 0x0 : Both normal and redundancy arrays are programmed. This is the normal way of programming. 0x1 : Only the normal array is programmed. 0x2 : Only the redundancy array is programmed. 0x3 : Reserved The value of this configuration field can be modified only when the controller is in an inactive mode (PDOWN, DSTBY, STBY). The setting will take effect when will be enabled again the PROG mode.	0x0
5	R/W	OTPC_MODE_HT_MARGIN_EN	Defines the temperature condition under which is performed a margin read. It affects only the initial margin read (RINI mode) and the programming verification margin read (PVFY). 0 : Regular temperature condition (less than 85°C) 1 : High temperature condition (85°C or more) The value of this configuration field can be modified only when the controller is in an inactive mode (PDOWN, DSTBY, STBY). The selection will take effect at the next PVFY or RINI mode that will be enabled. The READ mode is not affected by the setting of this configuration bit.	0x0
4	R/W	OTPC_MODE_USE_TST_ROW	Selects the memory area of the OTP cell that will be used. 0 - Uses the main memory area of the OTP cell	0x0

Bit	Mode	Symbol	Description	Reset
			1 - Uses the test row of the OTP cell The value of this configuration field can be modified only when the controller is in an inactive mode (PDOWN, DSTBY, STBY). The selection will take effect at the next programming or reading mode that will be enabled.	
3	-	-	Reserved	0x0
2:0	R/W	OTPC_MODE_MODE	<p>Defines the mode of operation of the OTPC controller. The encoding of the modes is as follows:</p> <p>0x0: PDOWN. The power supply of the OTP memory is OFF.</p> <p>0x1: DSTBY. The OTP memory is in deep standby mode (power supply ON and internal LDO OFF).</p> <p>0x2: STBY. The OTP memory is powered (power supply ON and internal LDO ON, but is not selected).</p> <p>0x3: READ. The OTP memory is in the normal read mode.</p> <p>0x4: PROG. The OTP memory is in programming mode.</p> <p>0x5: PVFY. The OTP memory is in programming verification mode (margin read after programming).</p> <p>0x6: RINI. The OTP memory is in initial read mode (initial margin read).</p> <p>0x7: Reserved.</p> <p>Whenever the OTPC_MODE_REG[MODE] is changing, the status bit OTPC_STAT_REG[OTPC_STAT_MRDY] gets the value zero. The new mode will be ready for use when the OTPC_STAT_MRDY become again 1. During the mode transition the OTPC_MODE_REG[MODE] become read only. Do not try to use or change any function of the controller until the OTPC_STAT_MRDY bit to become equal to 1.</p>	0x0

Table 234: OTPC_STAT_REG (0x30070004)

Bit	Mode	Symbol	Description	Reset
31:3	-	-	Reserved	0x0
2	R	OTPC_STAT_MRDY	<p>Indicates the progress of the transition from a mode of operation to a new mode of operation.</p> <p>0 : There is a transition in progress in a new mode of operation . Wait until the transition to be completed.</p> <p>1 : The transition to the new mode of operation has been completed. The function that has been enabled by the new mode can be used. A new mode can be applied.</p> <p>This status bit gets the value zero every time where the OTPC_MODE_REG[MODE] is changing. Do not try to use or change any function of the controller until this status bit to becomes equal to 1.</p>	0x1
1	R	OTPC_STAT_PBUF_EMPTY	<p>Indicates the status of the programming buffer (PBUF).</p> <p>0 : The PBUF contains the address and the data of a programming request. The OTPC_PADDR_REG and the OTPC_PWORD_REG should not be written as long as this status bit is zero.</p>	0x1

Bit	Mode	Symbol	Description	Reset
			<p>1 : The PBUF is empty and a new programming request can be registered in the PBUF by using the OTPC_PADDR_REG and the OTPC_PWORD_REG registers.</p> <p>This status bit gets the value zero every time where a programming is triggered by the OTPC_PADDR_REG (only if the PROG mode is active).</p>	
0	R	OTPC_STAT_PRDY	<p>Indicates the state of the programming process.</p> <p>0: The controller is busy. A programming is in progress. 1: The logic which performs programming is idle.</p>	0x1

Table 235: OTPC_PADDR_REG (0x30070008)

Bit	Mode	Symbol	Description	Reset
31:10	-	-	Reserved	0x0
9:0	R/W	OTPC_PADDR	<p>The OTPC_PADDR_REG and the OTPC_PWORD_REG consist the PBUF buffer that keeps the information that will be programmed in the OTP, by using the PROG mode. The PBUF holds the address (OTPC_PADDR_REG) and the data (OTPC_PWORD_REG) of each of the programming requests that are applied in the OTP memory.</p> <p>The OTPC_PADDR_REG refers to a word address. The OTPC_PADDR_REG has to be written after the OTP_PWORD_REG and only if the OTPC_STAT_REG[OTPC_STAT_PBUF_EMPTY]=1. The register is read only for as long the PBUF is not empty (OTPC_STAT_REG[OTPC_STAT_PBUF_EMPTY]=0). A writing to the OTPC_PADDR_REG triggers the controller to start the programming procedure (only if the PROG mode is active).</p>	0x0

Table 236: OTPC_PWORD_REG (0x3007000C)

Bit	Mode	Symbol	Description	Reset
31:0	R/W	OTPC_PWORD	<p>The OTPC_PADDR_REG and the OTPC_PWORD_REG consist the PBUF buffer that keeps the information that will be programmed in the OTP memory, by using the PROG mode. The PBUF holds the address (OTPC_PADDR_REG) and the data (OTPC_PWORD_REG) of each of the programming requests that are applied in the OTP memory.</p> <p>The OTP_PWORD_REG must be written before the OTPC_PADDR_REG and only if OTPC_STAT_REG[OTPC_STAT_PBUF_EMPTY] = 1. The register is read only for as long the PBUF is not empty (OTPC_STAT_REG[OTPC_STAT_PBUF_EMPTY]=0).</p>	0x0

Table 237: **OTPC_TIM1_REG** (0x30070010)

Bit	Mode	Symbol	Description	Reset
31	-	-	Reserved	0x0
30:24	R/W	OTPC_TIM1_US_T_C SP	The number of microseconds (minus one) that are required after the selection of the OTP memory, until to be ready for programming. It must be : - at least 10us - no more than 100us	0x9
23:20	R/W	OTPC_TIM1_US_T_C S	The number of microseconds (minus one) that are required after the selection of the OTP memory, until to be ready for any kind of read. It must be at least 10us.	0x9
19:16	R/W	OTPC_TIM1_US_T_P L	The number of microseconds (minus one) that are required until to be enabled the LDO of the OTP. It must be at least 10us.	0x9
15	-	-	Reserved	0x0
14:12	R/W	OTPC_TIM1_CC_T_R D	Defines the number of hclk_c clock periods that give a time interval at least higher than 120ns. The calculation of the time interval is performed like this : $2 * (OTPC_TIM1_CC_T_RD + 1) * hclk_clock_period > 120$ ns. This timing parameter refers to the access time of the OTP memory.	0x1
11:10	-	-	Reserved	0x0
9:8	R/W	OTPC_TIM1_CC_T_2 ONS	The number of hclk_c clock periods (minus one) that give a time interval that is at least higher than 20 ns.	0x0
7	-	-	Reserved	0x0
6:0	R/W	OTPC_TIM1_CC_T_1 US	The number of hclk_c clock periods (minus one) that give a time interval equal to 1us. This setting affects all the timing parameters that refer to microseconds, due to that defines the correspondence of a microsecond to a number of hclk_c clock cycles.	0x1F

Table 238: **OTPC_TIM2_REG** (0x30070014)

Bit	Mode	Symbol	Description	Reset
31	R/W	OTPC_TIM2_US_ADD _CC_EN	Adds an additional hclk_c clock cycle at all the time intervals that count in microseconds. 0 : The extra hclk_c clock cycle is not applied 1 : The extra hclk_c clock cycle is applied	0x1
30:29	R/W	OTPC_TIM2_US_T_S AS	The number of microseconds (minus one) that are required after the exit from the deep sleep standby mode and before to become ready to enter in an active mode (reading or programming). It must be at least 2us.	0x1
28:24	R/W	OTPC_TIM2_US_T_P PH	The number of microseconds (minus one) that are required after the last programming pulse and before to be disabled the programming mode in the OTP memory. It must be: - at least 5us - no more than 20us	0x4
23:21	R/W	OTPC_TIM2_US_T_V DS	The number of microseconds (minus one) that are required after the enabling of the power supply of the OTP memory and before to become ready for the enabling of the internal LDO. It must be at least 1us.	0x0

Bit	Mode	Symbol	Description	Reset
20:16	R/W	OTPC_TIM2_US_T_P PS	The number of microseconds (minus one) that are required after the enabling of the programming in the OTP memory and before to be applied the first programming pulse. It must be : - at least 5us - no more than 20us	0x4
15	-	-	Reserved	0x0
14:8	R/W	OTPC_TIM2_US_T_P PR	The number of microseconds (minus one) for recovery after a programming sequence. It must be : - at least 5us - no more than 100us	0x4
7:5	R/W	OTPC_TIM2_US_T_P WI	The number of microseconds (minus one) between two consecutive programming pulses. It must be : - at least 1us - no more than 5us	0x0
4:0	R/W	OTPC_TIM2_US_T_P W	The number of microseconds (minus one) that lasts the programming of each bit. It must be : - at least 10us - no more than 20us	0x9

42.6 LED Controller Registers

Table 239: Register map PWM for LEDs

Address	Register	Description
0x50030500	PWMLED_DUTY_CYCLE_LED1_REG	Defines duty cycle for PWM1
0x50030504	PWMLED_DUTY_CYCLE_LED2_REG	Defines duty cycle for PWM2
0x50030508	PWMLED_FREQUENCY_REG	Defines the PWM frequency
0x5003050C	PWMLED_CTRL_REG	PWM Control register

Table 240: PWMLED_DUTY_CYCLE_LED1_REG (0x50030500)

Bit	Mode	Symbol	Description	Reset
15:8	R/W	LED1_PWM_START_CYCLE	Defines the cycle in which the PWM becomes high. if start_cycle is larger than freq or end_cycle is equal to start_cycle, pwm out is always 0	0x0
7:0	R/W	LED1_PWM_END_CYCLE	Defines the cycle in which the PWM becomes low. If end_cycle is larger than freq and start_cycle is not larger than freq, output is always 1	0x0

Table 241: PWMLED_DUTY_CYCLE_LED2_REG (0x50030504)

Bit	Mode	Symbol	Description	Reset
15:8	R/W	LED2_PWM_START_CYCLE	Defines the cycle in which the PWM becomes high. if start_cycle is larger than freq or end_cycle is equal to start_cycle, pwm out is always 0	0x0
7:0	R/W	LED2_PWM_END_CYCLE	Defines the cycle in which the PWM becomes low. If end_cycle is larger then freq and start_cycle is not larger then freq, output is always 1	0x0

Table 242: PWMLED_FREQUENCY_REG (0x50030508)

Bit	Mode	Symbol	Description	Reset
7:0	R/W	LED_PWM_FREQUENCY	Defines the frequency of PWM 1 2, period = PWM_CLK * (FREQ+1)	0x0

Table 243: PWMLED_CTRL_REG (0x5003050C)

Bit	Mode	Symbol	Description	Reset
13:11	R/W	LED2_LOAD_SEL	Defines LED2 output current: 2.5mA + (LED2_LOAD_SEL*2.5mA). Max = 20mA.	0x0
10:8	R/W	LED1_LOAD_SEL	Defines LED1 output current: 2.5mA + (LED1_LOAD_SEL*2.5mA). Max = 20mA.	0x0
7	R/W	LED2_EN	0 = LED2 disabled 1 = LED2 enabled	0x0
6	R/W	LED1_EN	0 = LED1 disabled 1 = LED1 enabled	0x0
5:2	R/W	LED_TRIM	LED current trimming bits	0x0
1	R/W	SW_PAUSE_EN	0 = PWM are not blocked by SW 1 = PWM 1 and 2 are paused	0x0
0	R/W	PWM_ENABLE	0 = PWM 1,2 are disabled 1 = PWM 1,2 are enabled	0x0

42.7 QSPI Flash Registers

Table 244: Register map QSPIC

Address	Register	Description
0x38000000	QSPIC_CTRLBUS_REG	SPI Bus control register for the Manual mode
0x38000004	QSPIC_CTRLMODE_REG	Mode Control register
0x38000008	QSPIC_RECVDATA_REG	Received data for the Manual mode
0x3800000C	QSPIC_BURSTCMDA_REG	The way of reading in Auto mode (command register A)
0x38000010	QSPIC_BURSTCMDDB_REG	The way of reading in Auto mode (command register B)
0x38000014	QSPIC_STATUS_REG	The status register of the QSPI controller

Address	Register	Description
0x38000018	QSPIC_WRITEDATA_REG	Write data to SPI Bus for the Manual mode
0x3800001C	QSPIC_READDATA_REG	Read data from SPI Bus for the Manual mode
0x38000020	QSPIC_DUMMYDATA_REG	Send dummy clocks to SPI Bus for the Manual mode
0x38000024	QSPIC_ERASECTRL_REG	QSPI Erase control register
0x38000028	QSPIC_ERASECMDA_REG	The way of erasing in Auto mode (command register A)
0x3800002C	QSPIC_ERASECMDDB_REG	The way of erasing in Auto mode (command register B)
0x38000030	QSPIC_BURSTBRK_REG	Read break sequence in Auto mode
0x38000034	QSPIC_STATUSCMD_REG	The way of reading the status of external device in Auto mode
0x38000038	QSPIC_CHKKERASE_REG	Check erase progress in Auto mode
0x3800003C	QSPIC_GP_REG	QSPI General Purpose control register
0x38000040	QSPIC_UCODE_START	QSPIC uCode memory
0x38000080	QSPIC_CTR_CTRL_REG	Control register for the decryption engine of the QSPIC
0x38000084	QSPIC_CTR_SADDR_REG	Start address of the encrypted content in the QSPI flash
0x38000088	QSPIC_CTR_EADDR_REG	End address of the encrypted content in the QSPI flash
0x3800008C	QSPIC_CTR_NONCE_0_3_REG	Nonce bytes 0 to 3 for the AES-CTR algorithm
0x38000090	QSPIC_CTR_NONCE_4_7_REG	Nonce bytes 4 to 7 for the AES-CTR algorithm
0x38000094	QSPIC_CTR_KEY_0_3_REG	Key bytes 0 to 3 for the AES-CTR algorithm
0x38000098	QSPIC_CTR_KEY_4_7_REG	Key bytes 4 to 7 for the AES-CTR algorithm
0x3800009C	QSPIC_CTR_KEY_8_11_REG	Key bytes 8 to 11 for the AES-CTR algorithm
0x380000A0	QSPIC_CTR_KEY_12_15_REG	Key bytes 12 to 15 for the AES-CTR algorithm
0x380000A4	QSPIC_CTR_KEY_16_19_REG	Key bytes 16 to 19 for the AES-CTR algorithm
0x380000A8	QSPIC_CTR_KEY_20_23_REG	Key bytes 20 to 23 for the AES-CTR algorithm
0x380000AC	QSPIC_CTR_KEY_24_27_REG	Key bytes 24 to 27 for the AES-CTR algorithm
0x380000B0	QSPIC_CTR_KEY_28_31_REG	Key bytes 28 to 31 for the AES-CTR algorithm

Table 245: QSPIC_CTRLBUS_REG (0x38000000)

Bit	Mode	Symbol	Description	Reset
31:5	-	-	Reserved	0x0
4	W	QSPIC_DIS_CS	Write 1 to disable the chip select (active low) when the controller is in Manual mode.	0x0
3	W	QSPIC_EN_CS	Write 1 to enable the chip select (active low) when the controller is in Manual mode.	0x0
2	W	QSPIC_SET_QUAD	Write 1 to set the bus mode in Quad mode when the controller is in Manual mode.	0x0
1	W	QSPIC_SET_DUAL	Write 1 to set the bus mode in Dual mode when the controller is in Manual mode.	0x0
0	W	QSPIC_SET_SINGLE	Write 1 to set the bus mode in Single SPI mode when the controller is in Manual mode.	0x0

Table 246: QSPIC_CTRLMODE_REG (0x38000004)

Bit	Mode	Symbol	Description	Reset
31:14	-	-	Reserved	0x0
13	R/W	QSPIC_USE_32BA	Controls the length of the address that the external memory device uses. 0: The external memory device uses 24 bits address. 1: The external memory device uses 32 bits address. The controller uses this bit in order to decide the number of the address bytes that has to transfer to the external device during Auto mode.	0x0
12	R/W	QSPIC_BUF_LIM_EN	This bit has meaning only for the read in auto mode. Defines the behavior of the controller when the internal buffer is full and there are more data to be retrieved for the current burst. 0: The access in the flash device is not terminated when the internal buffer has no empty space. In this case the QSPI_SCK clock is blocked until to free space in the internal buffer. 1: The access in the flash device is terminated when the internal buffer has no empty space. A new access in the flash device will be initiated when will be requested addresses that are not present in the internal buffer. In both cases the access in the flash device is terminated when there is no any read request.	0x0
11:9	R/W	QSPIC_PCLK_MD	Read pipe clock delay relative to the falling edge of QSPI_SCK. Refer to QSPI Timing for timing parameters and recommended values: 0 to 7	0x0
8	R/W	QSPIC_RPIPE_EN	Controls the use of the data read pipe. 0: The read pipe is disabled; the sampling clock is defined according to the QSPIC_RXD_NEG setting. 1: The read pipe is enabled. The delay of the sampling clock is defined according to the QSPI_PCLK_MD setting. (Recommended)	0x0
7	R/W	QSPIC_RXD_NEG	Defines the clock edge that is used for the capturing of the received data, when the read pipe is not active (QSPIC_RPIPE_EN = 0).	0x0

Bit	Mode	Symbol	Description	Reset
			<p>0: Sampling of the received data with the positive edge of the QSPI_SCK</p> <p>1: Sampling of the received data with the negative edge of the QSPI_SCK</p> <p>The internal QSPI_SCK clock that is used by the controller for the capturing of the received data has a skew in respect of the QSPI_SCK that is received by the external memory device. In order to be improved the timing requirements of the read path, the controller supports a read pipe register with programmable clock delay. See also the QSPIC_RPIPE_EN register.</p>	
6	R/W	QSPIC_HRDY_MD	<p>This configuration bit is useful when the frequency of the QSPI clock is much lower than the clock of the AMBA bus, in order to not locks the AMBA bus for a long time.</p> <p>0: Adds wait states via hready signal when an access is performed on the QSPIC_WRITEDATA, QSPIC_READDATA and QSPIC_DUMMYDATA registers. It is not needed to checked the QSPIC_BUSY of the QSPIC_STATUS_REG.</p> <p>1: The controller don't adds wait states via the hready signal, when is performed access on the QSPIC_WRITEDATA, QSPIC_READDATA and QSPIC_DUMMYDATA registers. The QSPIC_BUSY bit of the QSPIC_STATUS_REG must be checked in order to be detected the completion of the requested access.</p> <p>It is applicable only when the controller is in Manual mode. In the case of the Auto mode, the controller always adds wait states via the hready signal.</p>	0x0
5	R/W	QSPIC_IO3_DAT	The value of QSPI_IO3 pad if QSPI_IO3_OEN is 1	0x0
4	R/W	QSPIC_IO2_DAT	The value of QSPI_IO2 pad if QSPI_IO2_OEN is 1	0x0
3	R/W	QSPIC_IO3_OEN	<p>QSPI_IO3 output enable. Use this only in SPI or Dual SPI mode to control /HOLD signal. When the Auto Mode is selected (QSPIC_AUTO_MD = 1) and the QUAD SPI is used, set this bit to zero.</p> <p>0: The QSPI_IO3 pad is input.</p> <p>1: The QSPI_IO3 pad is output.</p>	0x0
2	R/W	QSPIC_IO2_OEN	<p>QSPI_IO2 output enable. Use this only in SPI or Dual SPI mode to control /WP signal. When the Auto Mode is selected (QSPIC_AUTO_MD = 1) and the QUAD SPI is used, set this bit to zero.</p> <p>0: The QSPI_IO2 pad is input.</p> <p>1: The QSPI_IO2 pad is output.</p>	0x0
1	R/W	QSPIC_CLK_MD	<p>Mode of the generated QSPI_SCK clock</p> <p>0: Use Mode 0 for the QSPI_CLK. The QSPI_SCK is low when QSPI_CS is high.</p> <p>1: Use Mode 3 for the QSPI_CLK. The QSPI_SCK is high when QSPI_CS is high.</p>	0x0
0	R/W	QSPIC_AUTO_MD	<p>Mode of operation</p> <p>0: The Manual Mode is selected.</p>	0x0

Bit	Mode	Symbol	Description	Reset
			1: The Auto Mode is selected. During an erasing the QSPIC_AUTO_MD goes in read only mode (see QSPIC_ERASE_EN)	

Table 247: QSPIC_RECVDATA_REG (0x38000008)

Bit	Mode	Symbol	Description	Reset
31:0	R	QSPIC_RECVDATA	This register contains the received data when the QSPIC_READDATA_REG register is used in Manual mode, in order to be retrieved data from the external memory device and QSPIC_HRDY_MD=1 && QSPIC_BUSY=0.	0x0

Table 248: QSPIC_BURSTCMDA_REG (0x3800000C)

Bit	Mode	Symbol	Description	Reset
31:30	R/W	QSPIC_DMY_TX_MD	It describes the mode of the SPI bus during the Dummy bytes phase. 0x0: Single SPI 0x1: Dual 0x2: Quad 0x3: Reserved	0x0
29:28	R/W	QSPIC_EXT_TX_MD	It describes the mode of the SPI bus during the Extra Byte phase. 0x0: Single SPI 0x1: Dual 0x2: Quad 0x3: Reserved	0x0
27:26	R/W	QSPIC_ADR_TX_MD	It describes the mode of the SPI bus during the address phase. 0x0: Single SPI 0x1: Dual 0x2: Quad 0x3: Reserved	0x0
25:24	R/W	QSPIC_INST_TX_MD	It describes the mode of the SPI bus during the instruction phase. 0x0: Single SPI 0x1: Dual 0x2: Quad 0x3: Reserved	0x0
23:16	R/W	QSPIC_EXT_BYTE	The value of an extra byte which will be transferred after address (only if QSPIC_EXT_BYTE_EN= 1). Usually this is the Mode Bits in Dual/Quad SPI I/O instructions.	0x0
15:8	R/W	QSPIC_INST_WB	Instruction Value for Wrapping Burst. This value is the selected instruction when QSPIC_WRAP_MD is equal to 1 and the access is a wrapping burst of length and size described by the bit fields QSPIC_WRAP_LEN and QSPIC_WRAP_SIZE respectively.	0x0
7:0	R/W	QSPIC_INST	Instruction Value for Incremental Burst or Single read access. This value is the selected instruction at the	0x0

Bit	Mode	Symbol	Description	Reset
			cases of incremental burst or single read access. Also this value is used when a wrapping burst is not supported (QSPIC_WRAP_MD)	

Table 249: QSPIC_BURSTCMBD_REG (0x38000010)

Bit	Mode	Symbol	Description	Reset
31:16	-	-	Reserved	0x0
15	R/W	QSPIC_DMY_FORCE	By setting this bit, the number of dummy bytes is forced to be equal to 3. In this case the QSPIC_DMY_NUM field is overruled and has no function. 0: The number of dummy bytes is controlled by the QSPIC_DMY_NUM field 1: Three dummy bytes are used. The QSPIC_DMY_NUM is overruled.	0x0
14:12	R/W	QSPIC_CS_HIGH_MIN	Between the transmissions of two different instructions to the flash memory, the SPI bus stays in idle state (QSPI_CS high) for at least this number of QSPI_SCK clock cycles. See the QSPIC_ERS_CS_HI register for some exceptions.	0x0
11:10	R/W	QSPIC_WRAP_SIZE	It describes the selected data size of a wrapping burst (QSPIC_WRAP_MD). 0x0: byte access (8-bits) 0x1: half word access (16 bits) 0x2: word access (32-bits) 0x3: Reserved	0x0
9:8	R/W	QSPIC_WRAP_LEN	It describes the selected length of a wrapping burst (QSPIC_WRAP_MD). 0x0: 4 beat wrapping burst 0x1: 8 beat wrapping burst 0x2: 16 beat wrapping burst 0x3: Reserved	0x0
7	R/W	QSPIC_WRAP_MD	Wrap mode 0: The QSPIC_INST is the selected instruction at any access. 1: The QSPIC_INST_WB is the selected instruction at any wrapping burst access of length and size described by the registers QSPIC_WRAP_LEN and QSPIC_WRAP_SIZE respectively. In all other cases the QSPIC_INST is the selected instruction. Use this feature only when the serial FLASH memory supports a special instruction for wrapping burst access.	0x0
6	R/W	QSPIC_INST_MD	Instruction mode 0: Transmit instruction at any burst access. 1: Transmit instruction only in the first access after the selection of Auto Mode.	0x0
5:4	R/W	QSPIC_DMY_NUM	Number of Dummy Bytes 0x0: Zero Dummy Bytes (Don't Send Dummy Bytes) 0x1: Send 1 Dummy Byte 0x2: Send 2 Dummy Bytes	0x0

Bit	Mode	Symbol	Description	Reset
			0x3: Send 4 Dummy Bytes When QSPIC_DMY_FORCE is enabled, the QSPIC_DMY_NUM is overruled. In this case the number of dummy bytes is defined by the QSPIC_DMY_FORCE and is equal to 3, independent of the value of the QSPIC_DMY_NUM.	
3	R/W	QSPIC_EXT_HF_DS	Extra Half Disable Output 0: if QSPIC_EXT_BYTE_EN=1, is transmitted the complete QSPIC_EXT_BYTE 1: if QSPIC_EXT_BYTE_EN=1, the output is disabled (hi-z) during the transmission of bits [3:0] of QSPIC_EXT_BYTE	0x0
2	R/W	QSPIC_EXT_BYTE_EN	Extra Byte Enable 0: Don't Send QSPIC_EXT_BYTE 1: Send QSPIC_EXT_BYTE	0x0
1:0	R/W	QSPIC_DAT_RX_MD	It describes the mode of the SPI bus during the data phase. 0x0: Single SPI 0x1: Dual 0x2: Quad 0x3: Reserved	0x0

Table 250: QSPIC_STATUS_REG (0x38000014)

Bit	Mode	Symbol	Description	Reset
31:1	-	-	Reserved	0x0
0	R	QSPIC_BUSY	The status of the SPI Bus. 0: The SPI Bus is idle 1: The SPI Bus is active. Read data, write data or dummy data activity is in progress. Has meaning only in Manual mode and only when QSPIC_HRDY_MD = 1.	0x0

Table 251: QSPIC_WRITEDATA_REG (0x38000018)

Bit	Mode	Symbol	Description	Reset
31:0	W	QSPIC_WRITEDATA	Writing to this register is generating a data transfer from the controller to the external memory device. The data written in this register, is then transferred to the memory using the selected mode of the SPI bus (SPI, Dual SPI, Quad SPI). The data size of the access to this register can be 32-bits / 16-bits/ 8-bits and is equal to the number of the transferred bits. This register has meaning only when the controller is in Manual mode.	0x0

Table 252: QSPIC_READDATA_REG (0x3800001C)

Bit	Mode	Symbol	Description	Reset
31:0	R	QSPIC_READDATA	A read access at this register generates a data transfer from the external memory device to the QSPIC controller. The data is transferred using the selected mode of the SPI bus (SPI, Dual SPI, Quad SPI). The data size of the access to this register can be 32-bits / 16-bits / 8-bits and is equal to the number of the transferred bits. This register has meaning only when the controller is in Manual mode.	0x0

Table 253: QSPIC_DUMMYDATA_REG (0x38000020)

Bit	Mode	Symbol	Description	Reset
31:0	W	QSPIC_DUMMYDATA	Writing to this register generates a number of clock pulses to the SPI bus. During the last clock of this activity in the SPI bus, the QSPI_IOx data pads are in hi-z state. The data size of the access to this register can be 32-bits / 16-bits / 8-bits. The number of generated pulses is equal to: (size of AHB bus access) / (size of SPI bus). The size of SPI bus is equal to 1, 2 or 4 for Single, Dual or Quad SPI mode respectively. This register has meaning only when the controller is in Manual mode.	0x0

Table 254: QSPIC_ERASECTRL_REG (0x38000024)

Bit	Mode	Symbol	Description	Reset
31:28	-	-	Reserved	0x0
27:25	R	QSPIC_ERS_STATE	It shows the progress of sector/block erasing (read only). 0x0: No Erase. 0x1: Pending erase request 0x2: Erase procedure is running 0x3: Suspended Erase procedure 0x4: Finishing the Erase procedure 0x5..0x7: Reserved	0x0
24	R/W	QSPIC_ERASE_EN	During Manual mode (QSPIC_AUTO_MD = 0). This bit is in read only mode. During Auto mode (QSPIC_AUTO_MD = 1). To request the erasing of the block/sector (QSPIC_ERS_ADDR, 12'b0) write 1 to this bit. This bit is cleared automatically with the end of the erasing. Until the end of erasing the QSPIC_ERASE_EN remains in read only mode. During the same period of time the controller remains in Auto Mode (QSPIC_AUTO_MD goes in read only mode).	0x0
23:4	R/W	QSPIC_ERS_ADDR	Defines the address of the block/sector that is requested to be erased. If QSPIC_USE_32BA = 0 (24 bits addressing), bits QSPIC_ERASECTRL_REG[23-12] determine the block/sector address bits [23-12]. QSPIC_ERASECTRL_REG[11-4] are ignored by the controller.	0x0

Bit	Mode	Symbol	Description	Reset
			If QSPIC_USE_32BA = 1 (32 bits addressing) bits QSPIC_ERASECTRL_REG[23-4] determine the block / sectors address bits [31:12]	
3:0	-	-	Reserved	0x0

Table 255: QSPIC_ERASECMDA_REG (0x38000028)

Bit	Mode	Symbol	Description	Reset
31:24	R/W	QSPIC_RES_INST	The code value of the erase resume instruction	0x0
23:16	R/W	QSPIC_SUS_INST	The code value of the erase suspend instruction.	0x0
15:8	R/W	QSPIC_WEN_INST	The code value of the write enable instruction.	0x0
7:0	R/W	QSPIC_ERS_INST	The code value of the erase instruction.	0x0

Table 256: QSPIC_ERASECMDDB_REG (0x3800002C)

Bit	Mode	Symbol	Description	Reset
31:30	-	-	Reserved	0x0
29:24	R/W	QSPIC_RESSUS_DLY	Defines a timer that counts the minimum allowed delay between an erase suspend command and the previous erase resume command (or the initial erase command). 0: Dont wait. The controller starts immediately to suspend the erase procedure. 1..63: The controller waits for at least this number of 222kHz clock cycles before the suspension of erasing. Time starts counting after the end of the previous erase resume command (or the initial erase command)	0x0
23:20	-	-	Reserved	0x0
19:16	R/W	QSPIC_ERSRES_HLD	The controller must stay without flash memory reading requests for this number of AMBA hclk clock cycles, before to perform the command of erase or erase resume 15 - 0	0x0
15	-	-	Reserved	0x0
14:10	R/W	QSPIC_ERS_CS_HI	After the execution of instructions: write enable, erase, erase suspend and erase resume, the QSPI_CS remains high for at least this number of qspi bus clock cycles.	0x0
9:8	R/W	QSPIC_EAD_TX_MD	The mode of the QSPI Bus during the address phase of the erase instruction 0x0: Single 0x1: Dual 0x2: Quad 0x3: Reserved	0x0
7:6	R/W	QSPIC_RES_TX_MD	The mode of the QSPI Bus during the transmission of the resume instruction 0x0: Single 0x1: Dual 0x2: Quad 0x3: Reserved	0x0

Bit	Mode	Symbol	Description	Reset
5:4	R/W	QSPIC_SUS_TX_MD	The mode of the QSPI Bus during the transmission of the suspend instruction. 0x0: Single 0x1: Dual 0x2: Quad 0x3: Reserved	0x0
3:2	R/W	QSPIC_WEN_TX_MD	The mode of the QSPI Bus during the transmission of the write enable instruction. 0x0: Single 0x1: Dual 0x2: Quad 0x3: Reserved	0x0
1:0	R/W	QSPIC_ERS_TX_MD	The mode of the QSPI Bus during the instruction phase of the erase instruction 0x0: Single 0x1: Dual 0x2: Quad 0x3: Reserved	0x0

Table 257: QSPIC_BURSTBRK_REG (0x38000030)

Bit	Mode	Symbol	Description	Reset
31:21	-	-	Reserved	0x0
20	R/W	QSPIC_SEC_HF_DS	Disable output during the transmission of the second half (QSPIC_BRK_WRD[3:0]). Setting this bit is only useful if QSPIC_BRK_EN = 1 and QSPIC_BRK_SZ = 1. 0: The controller drives the QSPI bus during the transmission of the QSPIC_BRK_WRD[3:0]. 1: The controller leaves the QSPI bus in Hi-Z during the transmission of the QSPIC_BRK_WORD[3:0].	0x0
19:18	R/W	QSPIC_BRK_TX_MD	The mode of the QSPI Bus during the transmission of the burst break sequence. 0x0: Single 0x1: Dual 0x2: Quad 0x3: Reserved	0x0
17	R/W	QSPIC_BRK_SZ	The size of Burst Break Sequence 0: One byte (Send QSPIC_BRK_WRD[15:8]) 1: Two bytes (Send QSPIC_BRK_WRD[15:0])	0x0
16	R/W	QSPIC_BRK_EN	Controls the application of a special command (read burst break sequence) that is used in order to force the device to abandon the continuous read mode. 0: The special command is not applied 1: The special command is applied This special command is applied by the controller to the external device under the following conditions: - the controller is in Auto mode - the QSPIC_INST_MD = 1	0x0

Bit	Mode	Symbol	Description	Reset
			<ul style="list-style-type: none"> - the previous command that has been applied in the external device was read - the controller want to apply to the external device a command different than the read. 	
15:0	R/W	QSPIC_BRK_WRD	This is the value of a special command (read burst break sequence) that is applied by the controller to the external memory device, in order to force the memory device to abandon the continuous read mode.	0x0

Table 258: QSPIC_STATUSCMD_REG (0x38000034)

Bit	Mode	Symbol	Description	Reset
31:23	-	-	Reserved	0x0
22	R/W	QSPIC_STSDLY_SEL	<p>Defines the timer which is used to count the delay that it has to wait before to read the FLASH Status Register, after an erase or an erase resume command.</p> <p>0: The delay is controlled by the QSPIC_RESSTS_DLY which counts on the qspi clock.</p> <p>1: The delay is controlled by the QSPIC_RESSUS_DLY which counts on the 222 kHz clock.</p>	0x0
21:16	R/W	QSPIC_RESSTS_DLY	<p>Defines a timer that counts the minimum required delay between the reading of the status register and of the previous erase or erase resume instruction.</p> <p>0: Dont wait. The controller starts to reading the Flash memory status register immediately.</p> <p>1..63: The controller waits for at least this number of QSPI_CLK cycles and afterwards it starts to reading the Flash memory status register. The timer starts to count after the end of the previous erase or erase resume command.</p> <p>The actual timer that will be used by the controller before the reading of the Flash memory status register is defined by the QSPIC_STSDLY_SEL.</p>	0x0
15	R/W	QSPIC_BUSY_VAL	<p>Defines the value of the Busy bit which means that the flash is busy.</p> <p>0: The flash is busy when the Busy bit is equal to 0.</p> <p>1: The flash is busy when the Busy bit is equal to 1.</p>	0x0
14:12	R/W	QSPIC_BUSY_POS	It describes who from the bits of status represents the Busy bit (7 - 0).	0x0
11:10	R/W	QSPIC_RSTAT_RX_M D	<p>The mode of the QSPI Bus during the receive status phase of the read status instruction</p> <p>0x0: Single</p> <p>0x1: Dual</p> <p>0x2: Quad</p> <p>0x3: Reserved</p>	0x0
9:8	R/W	QSPIC_RSTAT_TX_M D	<p>The mode of the QSPI Bus during the instruction phase of the read status instruction.</p> <p>0x0: Single</p> <p>0x1: Dual</p> <p>0x2: Quad</p>	0x0

Bit	Mode	Symbol	Description	Reset
			0x3: Reserved	
7:0	R/W	QSPIC_RSTAT_INST	The code value of the read status instruction. It is transmitted during the instruction phase of the read status instruction.	0x0

Table 259: QSPIC_CHCKERASE_REG (0x38000038)

Bit	Mode	Symbol	Description	Reset
31:0	W	QSPIC_CHCKERASE	Writing any value to this register during erasing, forces the controller to read the flash memory status register. Depending on the value of the Busy bit, it updates the QSPIC_ERASE_EN.	0x0

Table 260: QSPIC_GP_REG (0x3800003C)

Bit	Mode	Symbol	Description	Reset
4:3	R/W	QSPIC_PADS_SLEW	QSPI pads slew rate control. Indicative values under certain conditions: 0: Rise=1.7 V/ns, Fall=1.9 V/ns (weak) 1: Rise=2.0 V/ns, Fall=2.3 V/ns 2: Rise=2.3 V/ns, Fall=2.6 V/ns 3: Rise=2.4 V/ns, Fall=2.7 V/ns (strong) Conditions: FLASH pin capacitance 6 pF, Vcc=1.8V, T=25C and Idrive=16mA.	0x0
2:1	R/W	QSPIC_PADS_DRV	QSPI pads drive current 0: 4 mA 1: 8 mA 2: 12 mA 3: 16 mA	0x0
0	-	-	Reserved	0x0

Table 261: QSPIC_UCODE_START (0x38000040)

Bit	Mode	Symbol	Description	Reset
31:0	R/W	QSPIC_UCODE_X	The controller has a dedicated memory cell of 16 words x 32 bits that is used for the storing of the microcode that describes the initialization process of the external flash device. The first word (word 0) of this memory can be accessed by accessing the QSPIC_UCODE_START register. The next words can be accessed by accessing the QSPIC_UCODE_START + 4*X (X=1 .. 15).	0x0

Table 262: QSPIC_CTR_CTRL_REG (0x38000080)

Bit	Mode	Symbol	Description	Reset
0	R/W	QSPIC_CTR_EN	Controls the AES-CTR decryption feature of the QSPIC, which enables the decryption (on-the-fly) of the data that are retrieved from the flash memory device. 0: The AES-CTR decryption is disabled.	0x0

Bit	Mode	Symbol	Description	Reset
			<p>1: The controller will decrypt the content of the flash memory device that is placed in the address space that is defined by the QSPIC_CTRL_SADDR_REG and QSPIC_CTRL_EADDR_REG registers. The data that are placed outside the previous space are not decrypted by the QSPIC. The decryption is performed by using the AES-CTR algorithm. The AES key is defined by the QSPIC_CTRL_KEY_x_y_REG registers and the nonce value by the QSPIC_CTRL_NONCE_x_y_REG registers.</p> <p>This configuration bit has meaning only while the controller is in Auto mode. The on-the-fly decryption is not provided in Manual mode.</p>	

Table 263: QSPIC_CTRL_SADDR_REG (0x38000084)

Bit	Mode	Symbol	Description	Reset
31:10	R/W	QSPIC_CTRL_SADDR	Defines the bits [31:10] of the start address in the flash memory, where an encrypted image is placed. The bits [9:0] are considered always as zero. This has meaning only when the decryption is active. See also the register QSPIC_CTRL_CTRL_REG[QSPIC_CTRL_EN].	0x0
9:0	-	-	Reserved	0x0

Table 264: QSPIC_CTRL_EADDR_REG (0x38000088)

Bit	Mode	Symbol	Description	Reset
31:10	R/W	QSPIC_CTRL_EADDR	Defines the bits [31:10] of the end address in the flash memory, where an encrypted image is placed. The bits [9:0] are considered always as 0x3ff. This has meaning only when the decryption is active. See also the register QSPIC_CTRL_CTRL_REG[QSPIC_CTRL_EN].	0x0
9:0	-	-	Reserved	0x3FF

Table 265: QSPIC_CTRL_NONCE_0_3_REG (0x3800008C)

Bit	Mode	Symbol	Description	Reset
31:0	R/W	QSPIC_CTRL_NONCE_0_3	<p>Defines the 8 bytes of the nonce value (N0 - N7) that is used by the AES-CTR algorithm in order to be constructed the counter block (CTRB). The total size of the counter block is 128 bits or 16 bytes :</p> <p>CTRB0 CTRB1 CTRB2 CTRB3...CTRB14 CTRB15.</p> <p>The first 8 bytes (CTRB0 - CTRB7) of the counter block consisted by the nonce value.</p> <p>The next 8 bytes of the counter block (CTRB8-CTRB15), are produced automatically by the hardware based on the address offset inside the encrypted image, from where are retrieved the requested data.</p> <p>The mapping of the nonce bytes to the corresponding QSPIC_CTRL_NONCE_X_Y_REG registers is the following :</p>	0x0

Bit	Mode	Symbol	Description	Reset
			<p>{CTRB0, CTRB1, CTRB2, CTRB3} = {N0, N1, N2, N3} = QSPIC_NONCE_0_3_REG[31:0] {CTRB4, CTRB5, CTRB6, CTRB7} = {N4, N5, N6, N7} = QSPIC_NONCE_4_7_REG[31:0]</p> <p>All these registers make sense only when QSPIC_CTRL_REG[QSPIC_CTRL_EN] = 1. Do not perform access to an encrypted address range while the updating process of the nonce value is in progress.</p>	

Table 266: QSPIC_CTRL_NONCE_4_7_REG (0x38000090)

Bit	Mode	Symbol	Description	Reset
31:0	R/W	QSPIC_CTRL_NONCE_4_7	See the description in the QSPIC_NONCE_0_3.	0x0

Table 267: QSPIC_CTRL_KEY_0_3_REG (0x38000094)

Bit	Mode	Symbol	Description	Reset
31:0	W	QSPIC_CTRL_KEY_0_3	<p>Defines the key that is used by the AES-CTR algorithm, when the on-the-fly decryption is enabled (QSPIC_CTRL_REG[QSPIC_CTRL_EN] = 1). The size of the decryption key is 256bits or 32 bytes :</p> <p>K0 K1 K2 K3...K30 K31.</p> <p>The mapping of the bytes to the corresponding QSPIC_CTRL_KEY_X_Y_REG registers is the following :</p> <p>{K0, K1, K2, K3} = QSPIC_CTRL_KEY_0_3_REG[31:0] {K4, K5, K6, K7} = QSPIC_CTRL_KEY_4_7_REG[31:0] {K8, K9, K10, K11} = QSPIC_CTRL_KEY_8_11_REG[31:0] {K12, K13, K14, K15} = QSPIC_CTRL_KEY_12_15_REG[31:0] {K16, K17, K18, K19} = QSPIC_CTRL_KEY_16_19_REG[31:0] {K20, K21, K22, K23} = QSPIC_CTRL_KEY_20_23_REG[31:0] {K24, K25, K26, K27} = QSPIC_CTRL_KEY_24_27_REG[31:0] {K28, K29, K30, K31} = QSPIC_CTRL_KEY_28_31_REG[31:0]</p> <p>All these registers make sense only when QSPIC_CTRL_REG[QSPIC_CTRL_EN] = 1. Do not perform access to an encrypted address range while the updating process of the decryption key is in progress.</p>	0x0

Table 268: QSPIC_CTRL_KEY_4_7_REG (0x38000098)

Bit	Mode	Symbol	Description	Reset
31:0	W	QSPIC_CTRL_KEY_4_7	See the description in the QSPIC_CTRL_KEY_0_3.	0x0

Table 269: QSPIC_CTRL_KEY_8_11_REG (0x3800009C)

Bit	Mode	Symbol	Description	Reset
31:0	W	QSPIC_CTRL_KEY_8_11	See the description in the QSPIC_CTRL_KEY_0_3.	0x0

Table 270: QSPIC_CTRL_KEY_12_15_REG (0x380000A0)

Bit	Mode	Symbol	Description	Reset
31:0	W	QSPIC_CTRL_KEY_12_15	See the description in the QSPIC_CTRL_KEY_0_3.	0x0

Table 271: QSPIC_CTRL_KEY_16_19_REG (0x380000A4)

Bit	Mode	Symbol	Description	Reset
31:0	W	QSPIC_CTRL_KEY_16_19	See the description in the QSPIC_CTRL_KEY_0_3.	0x0

Table 272: QSPIC_CTRL_KEY_20_23_REG (0x380000A8)

Bit	Mode	Symbol	Description	Reset
31:0	W	QSPIC_CTRL_KEY_20_23	See the description in the QSPIC_CTRL_KEY_0_3.	0x0

Table 273: QSPIC_CTRL_KEY_24_27_REG (0x380000AC)

Bit	Mode	Symbol	Description	Reset
31:0	W	QSPIC_CTRL_KEY_24_27	See the description in the QSPIC_CTRL_KEY_0_3.	0x0

Table 274: QSPIC_CTRL_KEY_28_31_REG (0x380000B0)

Bit	Mode	Symbol	Description	Reset
31:0	W	QSPIC_CTRL_KEY_28_31	See the description in the QSPIC_CTRL_KEY_0_3.	0x0

42.8 QSPI Ram Registers

Table 275: Register map QSPIC2

Address	Register	Description
0x34000000	QSPIC2_CTRLBUS_REG	SPI Bus control register for the Manual mode

Address	Register	Description
0x34000004	QSPIC2_CTRLMODE_REG	Mode control register
0x34000008	QSPIC2_RECVDATA_REG	Received data for the Manual mode
0x3400000C	QSPIC2_BURSTCMDA_REG	The way of reading in Auto mode (command register A)
0x34000010	QSPIC2_BURSTCMDDB_REG	The way of reading in Auto mode (command register B)
0x34000014	QSPIC2_STATUS_REG	The status register of the QSPI controller
0x34000018	QSPIC2_WRITEDATA_REG	Write data to SPI Bus for the Manual mode
0x3400001C	QSPIC2_READDATA_REG	Read data from SPI Bus for the Manual mode
0x34000020	QSPIC2_DUMMYDATA_REG	Send dummy clocks to SPI Bus for the Manual mode
0x34000024	QSPIC2_ERASECTRL_REG	Erase control register
0x34000028	QSPIC2_ERASECMDA_REG	The way of erasing in Auto mode (command register A)
0x3400002C	QSPIC2_ERASECMDDB_REG	The way of erasing in Auto mode (command register B)
0x34000030	QSPIC2_BURSTBRK_REG	Read break sequence in Auto mode
0x34000034	QSPIC2_STATUSCMD_REG	The way of reading the status of external device in Auto mode
0x34000038	QSPIC2_CHKKERASE_REG	Check erase progress in Auto mode
0x3400003C	QSPIC2_GP_REG	General purpose QSPIC2 register
0x34000040	QSPIC2_AWRITECMD_REG	The way of writing in Auto mode when the external device is a serial SRAM
0x34000044	QSPIC2_MEMBLLEN_REG	External memory burst length configuration

Table 276: QSPIC2_CTRLBUS_REG (0x34000000)

Bit	Mode	Symbol	Description	Reset
31:5	-	-	Reserved	0x0
4	W	QSPIC_DIS_CS	Write 1 to disable the chip select (active low) when the controller is in Manual mode.	0x0
3	W	QSPIC_EN_CS	Write 1 to enable the chip select (active low) when the controller is in Manual mode.	0x0
2	W	QSPIC_SET_QUAD	Write 1 to set the bus mode in Quad mode when the controller is in Manual mode.	0x0
1	W	QSPIC_SET_DUAL	Write 1 to set the bus mode in Dual mode when the controller is in Manual mode.	0x0
0	W	QSPIC_SET_SINGLE	Write 1 to set the bus mode in Single SPI mode when the controller is in Manual mode.	0x0

Table 277: QSPIC2_CTRLMODE_REG (0x34000004)

Bit	Mode	Symbol	Description	Reset
31:17	-	-	Reserved	0x0
16	R/W	QSPIC_CLK_FREE_EN	<p>Controls the behavior of the QSPI_SCK when the QSPI_CS is high and the QSPIC_CS_MD=1.</p> <p>0: Is produced one QSPI_SCK clock pulse after each 0 to 1 transition in the QSPI_CS.</p> <p>1: The QSPI_SCK clock remains always active, while the QSPI_CS is inactive.</p> <p>This setting has meaning only when the QSPIC_CS_MD=1.</p>	0x0
15	R/W	QSPIC_CS_MD	<p>Controls the clock edge with which is produced the QSPI_CS signal.</p> <p>0: The QSPI_CS is produced with the rising edge of the QSPI_SCK. The QSPI_SCK is always inactive while the QSPI_CS is high.</p> <p>1: The QSPI_CS is produced with the falling edge of the QSPI_SCK. The behavior of the QSPI_SCK while the QSPI_CS is high, is controlled by the QSPIC_CLK_FREE_EN.</p>	0x0
14	R/W	QSPIC_SRAM_EN	<p>Defines the type of the external device that is connected on the QSPIC controller</p> <p>0: The external memory device is a serial Flash</p> <p>1: The external memory device is a serial SRAM</p> <p>When the external device is a serial SRAM, the erase suspend/ resume functionality of the controller is disabled. In this case the writing of the QSPIC_ERASECTRL_REG[QSPIC_ERASE_EN] bit has no effect. Also, the memory space where the external device is mapped, is considered as writable.</p>	0x0
13	R/W	QSPIC_USE_32BA	<p>Controls the length of the address that the external memory device uses.</p> <p>0: The external memory device uses 24 bits address.</p> <p>1: The external memory device uses 32 bits address.</p> <p>The controller uses this bit in order to decide the number of the address bytes that has to transfer to the external device during Auto mode.</p>	0x0
12	R/W	QSPIC_FORCENSEQ_EN	<p>Controls the way with which is addressed by the QSPI controller a burst request from the AMBA bus.</p> <p>0: The controller translates a burst access on the AMBA bus as a burst access on the QSPI bus. That results to the minimum number of command/address phases.</p> <p>1: The controller will split a burst access on the AMBA bus into a number of single accesses on the QSPI bus. That results to a separate command for each beat of the burst. E.g a 4-beat word incremental AMBA read access will be split into 4 different sequences on the QSPI bus: command/address/extra clock/read data. The QSPI_CS will be low only for the time that is needed for each of these single access.</p>	0x0

Bit	Mode	Symbol	Description	Reset
			This configuration bit is useful when the clock frequency of the QSPI bus is much higher than the clock of the AMBA bus. In this case the interval for which the CS remains low is minimized, achieving lower power dissipation with respect of the case where the QSPIC_FORCENSEQ_EN=0, at cost of performance.	
11:9	R/W	QSPIC_PCLK_MD	Controls the read pipe clock delay relative to the falling edge of QSPI_SCK. Refer to QSPI Timing for timing parameters	0x0
8	R/W	QSPIC_RPIPE_EN	Controls the use of the data read pipe. 0: The read pipe is disabled, the sampling clock is defined according to the QSPIC_RXD_NEG setting. 1: The read pipe is enabled. The delay of the sampling clock is defined according to the QSPI_PCLK_MD setting. (Recommended)	0x0
7	R/W	QSPIC_RXD_NEG	Defines the clock edge that is used for the capturing of the received data, when the read pipe is not active (QSPIC_RPIPE_EN = 0). 0: Sampling of the received data with the positive edge of the QSPI_SCK 1: Sampling of the received data with the negative edge of the QSPI_SCK The internal QSPI_SCK clock that is used by the controller for the capturing of the received data has a skew in respect of the QSPI_SCK that is received by the external memory device. In order to be improved the timing requirements of the read path, the controller supports a read pipe register with programmable clock delay. See also the QSPIC_RPIPE_EN register.	0x0
6	R/W	QSPIC_HRDY_MD	This configuration bit is useful when the frequency of the QSPI clock is much lower than the clock of the AMBA bus, in order to not locks the AMBA bus for a long time. 0: Adds wait states via hready signal when an access is performed on the QSPIC_WRITEDATA, QSPIC_READDATA and QSPIC_DUMMYDATA registers. It is not needed to checked the QSPIC_BUSY of the QSPIC_STATUS_REG. 1: The controller don't adds wait states via the hready signal, when is performed access on the QSPIC_WRITEDATA, QSPIC_READDATA and QSPIC_DUMMYDATA registers. The QSPIC_BUSY bit of the QSPIC_STATUS_REG must be checked in order to be detected the completion of the requested access. It is applicable only when the controller is in Manual mode. In the case of the Auto mode, the controller always adds wait states via the hready signal.	0x0
5	R/W	QSPIC_IO3_DAT	The value of QSPI_IO3 pad if QSPI_IO3_OEN is 1	0x0
4	R/W	QSPIC_IO2_DAT	The value of QSPI_IO2 pad if QSPI_IO2_OEN is 1	0x0
3	R/W	QSPIC_IO3_OEN	QSPI_IO3 output enable. Use this only in SPI or Dual SPI mode to control /HOLD signal. When the Auto Mode is selected (QSPIC_AUTO_MD = 1) and the QUAD SPI is used, set this bit to zero.	0x0

Bit	Mode	Symbol	Description	Reset
			0: The QSPI_IO3 pad is input. 1: The QSPI_IO3 pad is output.	
2	R/W	QSPIC_IO2_OEN	QSPI_IO2 output enable. Use this only in SPI or Dual SPI mode to control /WP signal. When the Auto Mode is selected (QSPIC_AUTO_MD = 1) and the QUAD SPI is used, set this bit to zero. 0: The QSPI_IO2 pad is input. 1: The QSPI_IO2 pad is output.	0x0
1	R/W	QSPIC_CLK_MD	Mode of the generated QSPI_SCK clock 0: Use Mode 0 for the QSPI_CLK. The QSPI_SCK is low when QSPI_CS is high. 1: Use Mode 3 for the QSPI_CLK. The QSPI_SCK is high when QSPI_CS is high. See also the register QSPIC_CS_MD and the QSPIC_CLK_FREE_EN	0x0
0	R/W	QSPIC_AUTO_MD	Mode of operation 0: The Manual Mode is selected. 1: The Auto Mode is selected. During an erasing the QSPIC_AUTO_MD goes in read only mode (see QSPIC_ERASE_EN)	0x0

Table 278: **QSPIC2_RECVDATA_REG (0x34000008)**

Bit	Mode	Symbol	Description	Reset
31:0	R	QSPIC_RECVDATA	This register contains the received data when the QSPIC_READDATA_REG register is used in Manual mode, in order to be retrieved data from the external memory device and QSPIC_HRDY_MD=1 && QSPIC_BUSY=0.	0x0

Table 279: **QSPIC2_BURSTCMDA_REG (0x3400000C)**

Bit	Mode	Symbol	Description	Reset
31:30	R/W	QSPIC_DMY_TX_MD	It describes the mode of the SPI bus during the Dummy bytes phase. 0x0: Single SPI 0x1: Dual 0x2: Quad 0x3: Reserved	0x0
29:28	R/W	QSPIC_EXT_TX_MD	It describes the mode of the SPI bus during the Extra Byte phase. 0x0: Single SPI 0x1: Dual 0x2: Quad 0x3: Reserved	0x0
27:26	R/W	QSPIC_ADR_TX_MD	It describes the mode of the SPI bus during the address phase. 0x0: Single SPI	0x0

Bit	Mode	Symbol	Description	Reset
			0x1: Dual 0x2: Quad 0x3: Reserved	
25:24	R/W	QSPIC_INST_TX_MD	It describes the mode of the SPI bus during the instruction phase. 0x0: Single SPI 0x1: Dual 0x2: Quad 0x3: Reserved	0x0
23:16	R/W	QSPIC_EXT_BYTE	The value of an extra byte which will be transferred after address (only if QSPIC_EXT_BYTE_EN= 1). Usually this is the Mode Bits in Dual/Quad SPI I/O instructions.	0x0
15:8	R/W	QSPIC_INST_WB	Instruction Value for Wrapping Burst. This value is the selected instruction when QSPIC_WRAP_MD is equal to 1 and the access is a wrapping burst of length and size described by the bit fields QSPIC_WRAP_LEN and QSPIC_WRAP_SIZE respectively.	0x0
7:0	R/W	QSPIC_INST	Instruction Value for Incremental Burst or Single read access. This value is the selected instruction at the cases of incremental burst or single read access. Also this value is used when a wrapping burst is not supported (QSPIC_WRAP_MD)	0x0

Table 280: QSPIC2_BURSTCMBD_REG (0x34000010)

Bit	Mode	Symbol	Description	Reset
31:16	-	-	Reserved	0x0
15	R/W	QSPIC_DMY_FORCE	By setting this bit, the number of dummy bytes is forced to be equal to 3. In this case the QSPIC_DMY_NUM field is overruled and has no function. 0: The number of dummy bytes is controlled by the QSPIC_DMY_NUM field 1: Three dummy bytes are used. The QSPIC_DMY_NUM is overruled.	0x0
14:12	R/W	QSPIC_CS_HIGH_MIN	Between the transmission of two different instructions to the flash memory, the qspi bus stays in idle state (QSPI_CS high) for at least this number of QSPI_SCK clock cycles. See the QSPIC_ERS_CS_HI and the QSPIC_WR_CS_HIGH_MIN registers for some exceptions.	0x0
11:10	R/W	QSPIC_WRAP_SIZE	It describes the selected data size of a wrapping burst (QSPIC_WRAP_MD). 0x0: Byte access (8-bits) 0x1: Half word access (16 bits) 0x2: Word access (32-bits) 0x3: Reserved	0x0
9:8	R/W	QSPIC_WRAP_LEN	It describes the selected length of a wrapping burst (QSPIC_WRAP_MD). 0x0: 4 beat wrapping burst 0x1: 8 beat wrapping burst	0x0

Bit	Mode	Symbol	Description	Reset
			0x2: 16 beat wrapping burst 0x3: Reserved	
7	R/W	QSPIC_WRAP_MD	Wrap mode 0: The QSPIC_INST is the selected instruction at any access. 1: The QSPIC_INST_WB is the selected instruction at any wrapping burst access of length and size described by the registers QSPIC_WRAP_LEN and QSPIC_WRAP_SIZE respectively. In all other cases the QSPIC_INST is the selected instruction. Use this feature only when the serial FLASH memory supports a special instruction for wrapping burst access.	0x0
6	R/W	QSPIC_INST_MD	Instruction mode 0: Transmit instruction at any burst access. 1: Transmit instruction only in the first access after the selection of Auto Mode.	0x0
5:4	R/W	QSPIC_DMY_NUM	Number of Dummy Bytes 0x0: Zero Dummy Bytes (Don't Send Dummy Bytes) 0x1: Send 1 Dummy Byte 0x2: Send 2 Dummy Bytes 0x3: Send 4 Dummy Bytes When QSPIC_DMY_FORCE is enabled, the QSPIC_DMY_NUM is overruled. In this case the number of dummy bytes is defined by the QSPIC_DMY_FORCE and is equal to 3, independent of the value of the QSPIC_DMY_NUM.	0x0
3	R/W	QSPIC_EXT_HF_DS	Extra Half Disable Output 0: if QSPIC_EXT_BYTE_EN=1 then transmit the complete QSPIC_EXT_BYTE 1: if QSPIC_EXT_BYTE_EN=1 then disable (hi-z) output during the transmission of bits [3:0] of QSPIC_EXT_BYTE	0x0
2	R/W	QSPIC_EXT_BYTE_EN	Extra Byte Enable 0: Don't Send QSPIC_EXT_BYTE 1: Send QSPIC_EXT_BYTE	0x0
1:0	R/W	QSPIC_DAT_RX_MD	It describes the mode of the SPI bus during the data phase. 0x0: Single SPI 0x1: Dual 0x2: Quad 0x3: Reserved	0x0

Table 281: QSPIC2_STATUS_REG (0x34000014)

Bit	Mode	Symbol	Description	Reset
31:1	-	-	Reserved	0x0
0	R	QSPIC_BUSY	The status of the SPI Bus.	0x0

Bit	Mode	Symbol	Description	Reset
			<p>0: The SPI Bus is idle</p> <p>1: The SPI Bus is active. Read data, write data or dummy data activity is in progress.</p> <p>Has meaning only in Manual mode and only when QSPIC_HRDY_MD = 1.</p>	

Table 282: QSPIC2_WRITEDATA_REG (0x34000018)

Bit	Mode	Symbol	Description	Reset
31:0	W	QSPIC_WRITEDATA	<p>Writing to this register is generating a data transfer from the controller to the external memory device. The data written in this register, is then transferred to the memory using the selected mode of the SPI bus (SPI, Dual SPI, Quad SPI). The data size of the access to this register can be 32-bits / 16-bits/ 8-bits and is equal to the number of the transferred bits.</p> <p>This register has meaning only when the controller is in Manual mode.</p>	0x0

Table 283: QSPIC2_READDATA_REG (0x3400001C)

Bit	Mode	Symbol	Description	Reset
31:0	R	QSPIC_READDATA	<p>A read access at this register generates a data transfer from the external memory device to the QSPIC controller. The data is transferred using the selected mode of the SPI bus (SPI, Dual SPI, Quad SPI). The data size of the access to this register can be 32-bits / 16-bits / 8-bits and is equal to the number of the transferred bits.</p> <p>This register has meaning only when the controller is in Manual mode.</p>	0x0

Table 284: QSPIC2_DUMMYDATA_REG (0x34000020)

Bit	Mode	Symbol	Description	Reset
31:0	W	QSPIC_DUMMYDATA	<p>Writing to this register generates a number of clock pulses to the SPI bus. During the last clock of this activity in the SPI bus, the QSPI_IOx data pads are in hi-z state. The data size of the access to this register can be 32-bits / 16-bits/ 8-bits. The number of generated pulses is equal to: (size of AHB bus access) / (size of SPI bus). The size of SPI bus is equal to 1, 2 or 4 for Single, Dual or Quad SPI mode respectively.</p> <p>This register has meaning only when the controller is in Manual mode.</p>	0x0

Table 285: QSPIC2_ERASECTRL_REG (0x34000024)

Bit	Mode	Symbol	Description	Reset
31:28	-	-	Reserved	0x0

Bit	Mode	Symbol	Description	Reset
27:25	R	QSPIC_ERS_STATE	It shows the progress of sector/block erasing (read only). 0x0: No Erase. 0x1: Pending erase request 0x2: Erase procedure is running 0x3: Suspended Erase procedure 0x4: Finishing the Erase procedure 0x5..0x7: Reserved	0x0
24	R/W	QSPIC_ERASE_EN	This bit has meaning only when the external device is a serial FLASH (QSPIC_SRAM_EN=0). During Manual mode (QSPIC_AUTO_MD = 0) : This bit is in read only mode. During Auto mode (QSPIC_AUTO_MD = 1). To request the erasing of the block/sector (QSPIC_ERS_ADDR, 12'b0) write 1 to this bit. This bit is cleared automatically with the end of the erasing. Until the end of erasing the QSPIC_ERASE_EN remains in read only mode. During the same period of time the controller remains in Auto Mode (QSPIC_AUTO_MD goes in read only mode). In the case where the external device is a serial SRAM (QSPIC_SRAM_EN=1) this bit is in read only mode.	0x0
23:4	R/W	QSPIC_ERS_ADDR	Defines the address of the block/sector that is requested to be erased. If QSPIC_USE_32BA = 0 (24 bits addressing), bits QSPIC_ERASECTRL_REG[23-12] determine the block/sector address bits [23-12]. QSPIC_ERASECTRL_REG[11-4] are ignored by the controller. If QSPIC_USE_32BA = 1 (32 bits addressing) bits QSPIC_ERASECTRL_REG[23-4] determine the block / sectors address bits [31:12]	0x0
3:0	-	-	Reserved	0x0

Table 286: QSPIC2_ERASECMDA_REG (0x34000028)

Bit	Mode	Symbol	Description	Reset
31:24	R/W	QSPIC_RES_INST	The code value of the erase resume instruction	0x0
23:16	R/W	QSPIC_SUS_INST	The code value of the erase suspend instruction.	0x0
15:8	R/W	QSPIC_WEN_INST	The code value of the write enable instruction.	0x0
7:0	R/W	QSPIC_ERS_INST	The code value of the erase instruction.	0x0

Table 287: QSPIC2_ERASECMDDB_REG (0x3400002C)

Bit	Mode	Symbol	Description	Reset
31:30	-	-	Reserved	0x0
29:24	R/W	QSPIC_RESSUS_DLY	Defines a timer that counts the minimum allowed delay between an erase suspend command and the previous erase resume command (or the initial erase command).	0x0

Bit	Mode	Symbol	Description	Reset
			0x00: Dont wait. The controller starts immediately to suspend the erase procedure. 0x01..0x3F: The controller waits for at least this number of 288 KHz clock cycles before the suspension of erasing. Time starts counting after the end of the previous erase resume command (or the initial erase command)	
23:20	-	-	Reserved	0x0
19:16	R/W	QSPIC_ERSRES_HLD	The controller must stay without flash memory reading requests for this number of AMBA hclk clock cycles, before to perform the command of erase or erase resume. Allowable range : 0xF - 0x0	0x0
15	-	-	Reserved	0x0
14:10	R/W	QSPIC_ERS_CS_HI	After the execution of instructions: write enable, erase, erase suspend and erase resume, the QSPI_CS remains high for at least this number of QSPI_SCK clock cycles.	0x0
9:8	R/W	QSPIC_EAD_TX_MD	The mode of the SPI Bus during the address phase of the erase instruction 0x0: Single SPI 0x1: Dual 0x2: Quad 0x3: Reserved	0x0
7:6	R/W	QSPIC_RES_TX_MD	The mode of the SPI Bus during the transmission of the resume instruction 0x0: Single SPI 0x1: Dual 0x2: Quad 0x3: Reserved	0x0
5:4	R/W	QSPIC_SUS_TX_MD	The mode of the SPI Bus during the transmission of the suspend instruction. 0x0: Single SPI 0x1: Dual 0x2: Quad 0x3: Reserved	0x0
3:2	R/W	QSPIC_WEN_TX_MD	The mode of the SPI Bus during the transmission of the write enable instruction. 0x0: Single SPI 0x1: Dual 0x2: Quad 0x3: Reserved	0x0
1:0	R/W	QSPIC_ERS_TX_MD	The mode of the SPI Bus during the instruction phase of the erase instruction 0x0: Single SPI 0x1: Dual 0x2: Quad 0x3: Reserved	0x0

Table 288: QSPIC2_BURSTBRK_REG (0x34000030)

Bit	Mode	Symbol	Description	Reset
31:21	-	-	Reserved	0x0
20	R/W	QSPIC_SEC_HF_DS	Disable output during the transmission of the second half (QSPIC_BRK_WRD[3:0]). Setting this bit is only useful if QSPIC_BRK_EN =1 and QSPIC_BRK_SZ= 1. 0: The controller drives the SPI bus during the transmission of the QSPIC_BRK_WRD[3:0]. 1: The controller leaves the SPI bus in Hi-Z during the transmission of the QSPIC_BRK_WORD[3:0].	0x0
19:18	R/W	QSPIC_BRK_TX_MD	The mode of the SPI Bus during the transmission of the read break sequence. 0x0: Single SPI 0x1: Dual 0x2: Quad 0x3: Reserved	0x0
17	R/W	QSPIC_BRK_SZ	The size of the read break sequence. 0: One byte (Send QSPIC_BRK_WRD[15:8]) 1: Two bytes (Send QSPIC_BRK_WRD[15:0])	0x0
16	R/W	QSPIC_BRK_EN	Controls the application of a special command (read break sequence) that is used in order to force the device to abandon the continuous read mode. 0: The special command is not applied 1: The special command is applied This special command is applied by the controller to the external device under the following conditions: - the controller is in Auto mode - the QSPIC_INST_MD = 1 - the previous command that has been applied in the external device was read - the controller want to apply to the external device a command different than the read.	0x0
15:0	R/W	QSPIC_BRK_WRD	This is the value of a special command (read break sequence) that is applied by the controller to the external memory device, in order to force the memory device to abandon the continuous read mode.	0x0

Table 289: QSPIC2_STATUSCMD_REG (0x34000034)

Bit	Mode	Symbol	Description	Reset
31:23	-	-	Reserved	0x0
22	R/W	QSPIC_STSDLY_SEL	Defines the timer which is used to count the delay that it has to wait before to read the FLASH Status Register, after an erase or an erase resume command. 0: The delay is controlled by the QSPIC_RESSTS_DLY which counts on the qspi clock. 1: The delay is controlled by the QSPIC_RESSUS_DLY which counts on the 288 kHz clock.	0x0

Bit	Mode	Symbol	Description	Reset
21:16	R/W	QSPIC_RESSTS_DLY	Defines a timer that counts the minimum required delay between the reading of the status register and of the previous erase or erase resume instruction. 0x00: Dont wait. The controller starts to reading the Flash memory status register immediately. 0x01..0x3F: The controller waits for at least this number of QSPI_CLK cycles and afterwards it starts to reading the Flash memory status register. The timer starts to count after the end of the previous erase or erase resume command. The actual timer that will be used by the controller before the reading of the Flash memory status register is defined by the QSPIC_STSDLY_SEL.	0x0
15	R/W	QSPIC_BUSY_VAL	Defines the value of the Busy bit which means that the flash is busy. 0: The flash is busy when the Busy bit is equal to 0. 1: The flash is busy when the Busy bit is equal to 1.	0x0
14:12	R/W	QSPIC_BUSY_POS	Defines the bit of the Flash status register which represents the Busy bit (0x7 - 0x0).	0x0
11:10	R/W	QSPIC_RSTAT_RX_M D	The mode of the SPI Bus during the reception phase of the read status instruction, where the value of status register is retrieved. 0x0: Single SPI 0x1: Dual 0x2: Quad 0x3: Reserved	0x0
9:8	R/W	QSPIC_RSTAT_TX_M D	The mode of the SPI Bus during the instruction phase of the read status instruction. 0x0: Single SPI 0x1: Dual 0x2: Quad 0x3: Reserved	0x0
7:0	R/W	QSPIC_RSTAT_INST	The code value of the read status instruction. It is transmitted during the instruction phase of the read status instruction.	0x0

Table 290: QSPIC2_CHKERASE_REG (0x34000038)

Bit	Mode	Symbol	Description	Reset
31:0	W	QSPIC_CHKERASE	Writing any value to this register during erasing, forces the controller to read the flash memory status register. Depending on the value of the Busy bit, it updates the QSPIC_ERASE_EN. This register has meaning only when the controller is in Auto mode and there is an erase in progress (QSPIC_ERASE_EN =1). It has no meaning when the external device is a serial SRAM.	0x0

Table 291: QSPIC2_GP_REG (0x3400003C)

Bit	Mode	Symbol	Description	Reset
4:3	R/W	QSPIC_PADS_SLEW	QSPI pads slew rate control. Indicative values under certain conditions: 0x0 : Rise=1.7 V/ns, Fall=1.9 V/ns (weak) 0x1 : Rise=2.0 V/ns, Fall=2.3 V/ns 0x2 : Rise=2.3 V/ns, Fall=2.6 V/ns 0x3 : Rise=2.4 V/ns, Fall=2.7 V/ns (strong) Conditions: FLASH pin capacitance 6pF, Vcc=1.8V, T=25C and Idrive=16mA	0x0
2:1	R/W	QSPIC_PADS_DRV	QSPI pads drive current 0x0 : 4 mA 0x1 : 8 mA 0x2 : 12 mA 0x3 : 16 mA	0x0
0	R/W	-	Reserved	0x0

Table 292: QSPIC2_AWRITECMD_REG (0x34000040)

Bit	Mode	Symbol	Description	Reset
31:19	-	-	Reserved	0x0
18:14	R/W	QSPIC_WR_CS_HIGH_MIN	After the execution of the write command, the QSPI_CS remains high for at least this number of QSPI_SCK clock cycles.	0x0
13:12	R/W	QSPIC_WR_DAT_TX_MD	The mode of the SPI Bus during the data phase of the write command. 0x0: Single SPI 0x1: Dual 0x2: Quad 0x3: Reserved	0x0
11:10	R/W	QSPIC_WR_ADR_TX_MD	The mode of the SPI Bus during the address phase of the write command. 0x0: Single SPI 0x1: Dual 0x2: Quad 0x3: Reserved	0x0
9:8	R/W	QSPIC_WR_INST_TX_MD	The mode of the SPI Bus during the instruction phase of the write command. 0x0: Single SPI 0x1: Dual 0x2: Quad 0x3: Reserved	0x0
7:0	R/W	QSPIC_WR_INST	This is the value of the instruction that is used, in order to be programmed the external SRAM device.	0x0

Table 293: QSPIC2_MEMBLLEN_REG (0x34000044)

Bit	Mode	Symbol	Description	Reset
31:14	-	-	Reserved	0x0

Bit	Mode	Symbol	Description	Reset
13:4	R/W	QSPIC_T_CEM_CC	<p>Defines the maximum allowed time tCEM for which the QSPIC_CS can stay active (QSPI_CS=0). It has meaning only when QSPIC_T_CEM_EN is equal to 1. See also the description of the QSPIC_T_CEM_EN for more details.</p> <p>The tCEM is expressed in number of qspi clock cycles and can be calculated as follows :</p> $tCEM / (qspi_clock_period)$ <p>If the result of the above equation is higher than 0x3FF, use the value 0x3FF.</p>	0x0
3	R/W	QSPIC_T_CEM_EN	<p>This bit enables the controlling of the maximum time tCEM for which the QSPI_CS remains active. It has meaning only when the Auto mode is active (QSPIC_AUTO_MD=1) and the external device is a serial SRAM (QSPIC_SRAM_EN=1). In the case where the external device is a serial Flash (QSPIC_SRAM_EN=0) or the controller is in Manual mode (QSPIC_AUTO_MD=0), this field has no any effect.</p> <p>This feature is usefull in the case where the external serial device is a dynamic RAM that requires refresh. If the refresh is applied only when the device is in the idle state (QSPI_CS = 1), the time for which the device remains in the active state (QSPI_CS = 0) should be limited by a maximum threshold.</p> <p>0:There is no any constraint regarding the maximum allowed time for which the QSPI_CS can stay active. This is the case also when QSPIC_SRAM_EN=0 or QSPIC_AUTO_MD=0.</p> <p>1:There is a maximum allowed time interval tCEM for which the QSPI_CS can stay active during a burst access (for reading or writing of data). For the controller this is considered as equal to QSPIC_T_CEM_CC x qspi_clock_period. In the case where the data transfer requires the QSPI_CS to stays active for more than QSPIC_T_CEM_CC qspi clock cycles, the QSPI controller splits the access on the SPI bus in more than one bursts, by inserting inactive periods (QSPI_CS = 0) between them. This will cost extra clock cycles for the realization of the original access, due to the additional commands that are required in the SPI bus.</p> <p>The value in the QSPIC_T_CEM_CC should be updated every time where the frequency of the qspi clock is modified. The qspi clock frequency should not be decreased more than a lowest frequency. This is the lowest frequency that enables the be performed a 32-bit word read and write access, without violating the tCEM timing requirement (the QSPI controller allows to be performed at least the transferring of one beat of the requested burst, independent of the QSPIC_T_CEM_CC limit).</p>	0x0

Bit	Mode	Symbol	Description	Reset
2:0	R/W	QSPIC_MEMBLLEN	<p>In this register is defined the expected behavior of the external memory device regarding the length of a burst operation :</p> <p>0x0: The external memory device is capable to implement incremental burst of unspecified length. 0x1: The external memory device implements a wrapping burst of length 4 bytes. 0x2: The external memory device implements a wrapping burst of length 8 bytes. 0x3: The external memory device implements a wrapping burst of length 16 bytes. 0x4: The external memory device implements a wrapping burst of length 32 bytes. 0x5: The external memory device implements a wrapping burst of length 64 bytes. 0x6 - 0x7 : Reserved</p> <p>This setting is used by the QSPI controller when the Auto mode is enabled (QSPIC_AUTO_MD=1), in order to handle the various burst requests of the AHB bus, in respect of the requirements of the external memory device.</p> <p>The external memory device may need to be configured by applying special instruction, in order to be defined the kind of the burst operation. This can be implemented by applying this special instruction with the QSPI controller in Manual mode (QSPIC_AUTO_MD=1). Refer to the datasheet of the external device for more information.</p>	0x0

42.9 RF Monitor Registers

Table 294: Register map RFPT

Address	Register	Description
0x50040600	RFMON_CTRL_REG	Control register
0x50040604	RFMON_ADDR_REG	AHB master start address
0x50040608	RFMON_LEN_REG	Data length register
0x5004060C	RFMON_STAT_REG	Status register
0x50040610	RFMON_CRV_ADDR_REG	AHB master current address
0x50040614	RFMON_CRV_LEN_REG	The remaining data to be transferred

Table 295: [RFMON_CTRL_REG](#) (0x50040600)

Bit	Mode	Symbol	Description	Reset
31:3	-	-	Reserved	0x0
2	R/W	RFMON_BREQ_FORCE	Write this bit with 1, when the required throughput for the transferring of the captured data is close to the capacity	0x0

Bit	Mode	Symbol	Description	Reset
			of the system bus/memory. The controller will be aggressive in the usage of the bus. The availability of the bus will be affected for the remaining masters.	
1	R/W	RFMON_CIRC_EN	Write with 1 to enable the circular mode. In circular mode the controller continuously writes data in to the memory until being disabled by software. Data are transferred in the circular buffer in the memory, as defined by RFMON_ADDR_REG and RFMON_LEN_REG registers. Disabling of the controller is realized by writing RFMON_PACK_EN with 0.	0x0
0	R/W	RFMON_PACK_EN	Starts capturing data from the test bus 0 : No data captured. 1 : Data captured. Should be written with 1 to start data acquisition. When the controller is not in circular mode (RFMON_CIRC_EN = 0) and after capturing a predefined number of words (RFMON_LEN), this bit will be auto cleared. In circular mode (RFMON_CIRC_EN = 1) the RFMON_PACK_EN remains 1 to be cleared by software.	0x0

Table 296: RFMON_ADDR_REG (0x50040604)

Bit	Mode	Symbol	Description	Reset
31:2	R/W	RFMON_ADDR	It is the bits [31:2] of base address that is used by the AHB master interface of the controller. Defines the AHB address where the controller will start storing data at. Bits [1:0] of the address are always considered to be 0.	0x0
1:0	-	-	Reserved	0x0

Table 297: RFMON_LEN_REG (0x50040608)

Bit	Mode	Symbol	Description	Reset
31:17	-	-	Reserved	0x0
16:0	R/W	RFMON_LEN	The number of words (minus one) that should be captured.	0x0

Table 298: RFMON_STAT_REG (0x5004060C)

Bit	Mode	Symbol	Description	Reset
31:2	-	-	Reserved	0x0
1	RW1C	RFMON_OFLOW_STK	Indicates that during transfer of data, at least one overflow has been detected. 0 : The transfer completed without overflows. 1 : At least one overflow occurred in the fifo. Write 1 to clear this bit.	0x0
0	R	RFMON_ACTIVE	Indicates the state of the controller. 0 : The controller is idle.	0x0

Bit	Mode	Symbol	Description	Reset
			1 : The controller is active. The capturing process and/or the dma activity is in progress. The controller will be activated (RFMON_ACTIVE == 1), when RFMON_PACK_EN will be written with 1. Will return to inactive state, after the end of the capturing process (RFMON_PACK_EN==0) and the completion of the transfer of all data to memory.	

Table 299: RFMON_CRV_ADDR_REG (0x50040610)

Bit	Mode	Symbol	Description	Reset
31:2	R	RFMON_CRV_ADDR	Bits [31:2] of AHB address that will be used by the controller in the next memory access. The bits [1:0] are always 0.	0x0
1:0	-	-	Reserved	0x0

Table 300: RFMON_CRV_LEN_REG (0x50040614)

Bit	Mode	Symbol	Description	Reset
31:17	-	-	Reserved	0x0
16:0	R	RFMON_CRV_LEN	Indicates the number of words (minus 1) that remain to be transferred.	0x0

42.10 Real Time Clock Registers

Table 301: Register map RTC

Address	Register	Description
0x50000400	RTC_CONTROL_REG	RTC Control Register
0x50000404	RTC_HOUR_MODE_REG	RTC Hour Mode Register
0x50000408	RTC_TIME_REG	RTC Time Register
0x5000040C	RTC_CALENDAR_REG	RTC Calendar Register
0x50000410	RTC_TIME_ALARM_REG	RTC Time Alarm Register
0x50000414	RTC_CALENDAR_ALARM_REG	RTC Calendar Alarm Register
0x50000418	RTC_ALARM_ENABLE_REG	RTC Alarm Enable Register
0x5000041C	RTC_EVENT_FLAGS_REG	RTC Event Flags Register
0x50000420	RTC_INTERRUPT_ENABLE_REG	RTC Interrupt Enable Register
0x50000424	RTC_INTERRUPT_DISABLE_REG	RTC Interrupt Disable Register
0x50000428	RTC_INTERRUPT_MASK_REG	RTC Interrupt Mask Register

Address	Register	Description
0x5000042C	RTC_STATUS_REG	RTC Status Register
0x50000430	RTC_KEEP_RTC_REG	RTC Keep RTC Register
0x50000480	RTC_EVENT_CTRL_REG	RTC Event Control Register
0x50000484	RTC_MOTOR_EVENT_PERIOD_REG	RTC Motor Event Period Register
0x50000488	RTC_PDC_EVENT_PERIOD_REG	RTC PDC Event Period Register
0x5000048C	RTC_PDC_EVENT_CLEAR_REG	RTC PDC Event Clear Register
0x50000490	RTC_MOTOR_EVENT_COUNTER_REG	RTC Motor Event Counter Register
0x50000494	RTC_PDC_EVENT_COUNTER_REG	RTC PDC Event Counter Register

Table 302: RTC_CONTROL_REG (0x50000400)

Bit	Mode	Symbol	Description	Reset
1	R/W	RTC_CAL_DISABLE	When this field is set high the RTC stops incrementing the calendar value.	0x1
0	R/W	RTC_TIME_DISABLE	When this field is set high the RTC stops incrementing the time value.	0x1

Table 303: RTC_HOUR_MODE_REG (0x50000404)

Bit	Mode	Symbol	Description	Reset
0	R/W	RTC_HMS	When this field is set high the RTC operates in 12 hour clock mode; otherwise, times are in 24 hour clock format.	0x0

Table 304: RTC_TIME_REG (0x50000408)

Bit	Mode	Symbol	Description	Reset
31	R/W	RTC_TIME_CH	The value in this register has altered since last read. Read and clear.	0x0
30	R/W	RTC_TIME_PM	In 12 hour clock mode, indicates PM when set.	0x0
29:28	R/W	RTC_TIME_HR_T	Hours tens. Represented in BCD digit (0-2).	0x0
27:24	R/W	RTC_TIME_HR_U	Hours units. Represented in BCD digit (0-9).	0x0
23	-	-	Reserved	0x0
22:20	R/W	RTC_TIME_M_T	Minutes tens. Represented in BCD digit (0-5).	0x0
19:16	R/W	RTC_TIME_M_U	Minutes units. Represented in BCD digit (0-9).	0x0
15	-	-	Reserved	0x0
14:12	R/W	RTC_TIME_S_T	Seconds tens. Represented in BCD digit (0-9).	0x0
11:8	R/W	RTC_TIME_S_U	Seconds units. Represented in BCD digit (0-9).	0x0
7:4	R/W	RTC_TIME_H_T	Hundredths of a second tens. Represented in BCD digit (0-9).	0x0

Bit	Mode	Symbol	Description	Reset
3:0	R/W	RTC_TIME_H_U	Hundredths of a second units. Represented in BCD digit (0-9).	0x0

Table 305: RTC_CALENDAR_REG (0x5000040C)

Bit	Mode	Symbol	Description	Reset
31	R/W	RTC_CAL_CH	The value in this register has altered since last read. Read and clear	0x0
30	-	-	Reserved	0x0
29:28	R/W	RTC_CAL_C_T	Century tens. Represented in BCD digit (1-2).	0x2
27:24	R/W	RTC_CAL_C_U	Century units. Represented in BCD digit (0-9).	0x0
23:20	R/W	RTC_CAL_Y_T	Year tens. Represented in BCD digit (0-9).	0x0
19:16	R/W	RTC_CAL_Y_U	Year units. Represented in BCD digit (0-9).	0x0
15:14	-	-	Reserved	0x0
13:12	R/W	RTC_CAL_D_T	Date tens. Represented in BCD digit (0-3).	0x0
11:8	R/W	RTC_CAL_D_U	Date units. Represented in BCD digit (0-9).	0x1
7	R/W	RTC_CAL_M_T	Month tens. Represented in BCD digit (0-1).	0x0
6:3	R/W	RTC_CAL_M_U	Month units. Represented in BCD digit (0-9).	0x1
2:0	R/W	RTC_DAY	Day of the week (arbitrary) units. Represented in BCD digit (0-7).	0x7

Table 306: RTC_TIME_ALARM_REG (0x50000410)

Bit	Mode	Symbol	Description	Reset
31	-	-	Reserved	0x0
30	R/W	RTC_TIME_PM	In 12 hour clock mode, indicates PM when set.	0x0
29:28	R/W	RTC_TIME_HR_T	Hours tens. Represented in BCD digit (0-2).	0x0
27:24	R/W	RTC_TIME_HR_U	Hours units. Represented in BCD digit (0-9).	0x0
23	-	-	Reserved	0x0
22:20	R/W	RTC_TIME_M_T	Minutes tens. Represented in BCD digit (0-5).	0x0
19:16	R/W	RTC_TIME_M_U	Minutes units. Represented in BCD digit (0-9).	0x0
15	-	-	Reserved	0x0
14:12	R/W	RTC_TIME_S_T	Seconds tens. Represented in BCD digit (0-9).	0x0
11:8	R/W	RTC_TIME_S_U	Seconds units. Represented in BCD digit (0-9).	0x0
7:4	R/W	RTC_TIME_H_T	Hundredths of a second tens. Represented in BCD digit (0-9).	0x0
3:0	R/W	RTC_TIME_H_U	Hundredths of a second units. Represented in BCD digit (0-9).	0x0

Table 307: RTC_CALENDAR_ALARM_REG (0x50000414)

Bit	Mode	Symbol	Description	Reset
31:14	R/W	-	Reserved	0x0
13:12	R/W	RTC_CAL_D_T	Date tens. Represented in BCD digit (0-3).	0x0

Bit	Mode	Symbol	Description	Reset
11:8	R/W	RTC_CAL_D_U	Date units. Represented in BCD digit (0-9).	0x0
7	R/W	RTC_CAL_M_T	Month tens. Represented in BCD digit (0-1).	0x0
6:3	R/W	RTC_CAL_M_U	Month units. Represented in BCD digit (0-9).	0x0
2:0	-	-	Reserved	0x0

Table 308: RTC_ALARM_ENABLE_REG (0x50000418)

Bit	Mode	Symbol	Description	Reset
5	R/W	RTC_ALARM_MNTH_EN	Alarm on month enable. Enable to trigger alarm when data specified in Calendar Alarm Register (M_T and M_U) has been reached.	0x0
4	R/W	RTC_ALARM_DATE_EN	Alarm on date enable. Enable to trigger alarm when data specified in Calendar Alarm Register (D_T and D_U) has been reached.	0x0
3	R/W	RTC_ALARM_HOUR_EN	Alarm on hour enable. Enable to trigger alarm when data specified in Time Alarm Register (PM, HR_T and HR_U) has been reached.	0x0
2	R/W	RTC_ALARM_MIN_EN	Alarm on minute enable. Enable to trigger alarm when data specified in Time Alarm Register (M_T and M_U) has been reached.	0x0
1	R/W	RTC_ALARM_SEC_EN	Alarm on second enable. Enable to trigger alarm when data specified in Time Alarm Register (S_T and S_U) has been reached.	0x0
0	R/W	RTC_ALARM_HOS_EN	Alarm on hundredths of a second enable. Enable to trigger alarm when data specified in Time Alarm Register (H_T and H_U) has been reached.	0x0

Table 309: RTC_EVENT_FLAGS_REG (0x5000041C)

Bit	Mode	Symbol	Description	Reset
6	R	RTC_EVENT_ALARM	Alarm event flag. Indicate that alarm event occurred since the last reset.	0x0
5	R	RTC_EVENT_MNTH	Month rolls over event flag. Indicate that month rolls over event occurred since the last reset.	0x0
4	R	RTC_EVENT_DATE	Date rolls over event flag. Indicate that date rolls over event occurred since the last reset.	0x0
3	R	RTC_EVENT_HOUR	Hour rolls over event flag. Indicate that hour rolls over event occurred since the last reset.	0x0
2	R	RTC_EVENT_MIN	Minute rolls over event flag. Indicate that minute rolls over event occurred since the last reset.	0x0
1	R	RTC_EVENT_SEC	Second rolls over event flag. Indicate that second rolls over event occurred since the last reset.	0x0
0	R	RTC_EVENT_HOS	Hundredths of a second event flag. Indicate that hundredths of a second rolls over event occurred since the last reset.	0x0

Table 310: RTC_INTERRUPT_ENABLE_REG (0x50000420)

Bit	Mode	Symbol	Description	Reset
6	W	RTC_ALARM_INT_EN	Interrupt on alarm enable. Enable to issue the interrupt when alarm event occurred.	0x0
5	W	RTC_MNTH_INT_EN	Interrupt on month enable. Enable to issue the interrupt when month event occurred.	0x0
4	W	RTC_DATE_INT_EN	Interrupt on date enable. Enable to issue the interrupt when date event occurred.	0x0
3	W	RTC_HOUR_INT_EN	Interrupt on hour enable. Enable to issue the interrupt when hour event occurred.	0x0
2	W	RTC_MIN_INT_EN	Interrupt on minute enable. Enable to issue the interrupt when minute event occurred.	0x0
1	W	RTC_SEC_INT_EN	Interrupt on second enable. Enable to issue the interrupt when second event occurred.	0x0
0	W	RTC_HOS_INT_EN	Interrupt on hundredths of a second enable. Enable to issue the interrupt when hundredths of a second event occurred.	0x0

Table 311: RTC_INTERRUPT_DISABLE_REG (0x50000424)

Bit	Mode	Symbol	Description	Reset
6	W	RTC_ALARM_INT_DIS	Interrupt on alarm disable. Disable to issue the interrupt when alarm event occurred.	0x0
5	W	RTC_MNTH_INT_DIS	Interrupt on month disable. Disable to issue the interrupt when month event occurred.	0x0
4	W	RTC_DATE_INT_DIS	Interrupt on date disable. Disable to issue the interrupt when date event occurred.	0x0
3	W	RTC_HOUR_INT_DIS	Interrupt on hour disable. Disable to issue the interrupt when hour event occurred.	0x0
2	W	RTC_MIN_INT_DIS	Interrupt on minute disable. Disable to issue the interrupt when minute event occurred.	0x0
1	W	RTC_SEC_INT_DIS	Interrupt on second disable. Disable to issue the interrupt when second event occurred.	0x0
0	W	RTC_HOS_INT_DIS	Interrupt on hundredths of a second disable. Disable to issue the interrupt when hundredths of a second event occurred.	0x0

Table 312: RTC_INTERRUPT_MASK_REG (0x50000428)

Bit	Mode	Symbol	Description	Reset
6	R	RTC_ALARM_INT_MSK	Mask alarm interrupt. It can be cleared (set) by setting corresponding bit (ALRM) in Interrupt Enable Register (Interrupt Disable Register).	0x1
5	R	RTC_MNTH_INT_MSK	Mask month interrupt. It can be cleared (set) by setting corresponding bit (MNTH) in Interrupt Enable Register (Interrupt Disable Register).	0x1
4	R	RTC_DATE_INT_MSK	Mask date interrupt. It can be cleared (set) by setting corresponding bit (DATE) in Interrupt Enable Register (Interrupt Disable Register).	0x1

Bit	Mode	Symbol	Description	Reset
3	R	RTC_HOUR_INT_MSK	IMask hour interrupt. It can be cleared (set) by setting corresponding bit (HOUR) in Interrupt Enable Register (Interrupt Disable Register).	0x1
2	R	RTC_MIN_INT_MSK	IMask minute interrupt. It can be cleared (set) by setting corresponding bit (MIN) in Interrupt Enable Register (Interrupt Disable Register).	0x1
1	R	RTC_SEC_INT_MSK	IMask second interrupt. It can be cleared (set) by setting corresponding bit (SEC) in Interrupt Enable Register (Interrupt Disable Register).	0x1
0	R	RTC_HOS_INT_MSK	Mask hundredths of a second interrupt. It can be cleared (set) by setting corresponding bit (HOS) in Interrupt Enable Register (Interrupt Disable Register).	0x1

Table 313: RTC_STATUS_REG (0x5000042C)

Bit	Mode	Symbol	Description	Reset
3	R	RTC_VALID_CAL_ALM	Valid Calendar Alarm. If cleared then indicates that invalid entry occurred when writing to Calendar Alarm Register.	0x1
2	R	RTC_VALID_TIME_ALM	Valid Time Alarm. If cleared then indicates that invalid entry occurred when writing to Time Alarm Register.	0x1
1	R	RTC_VALID_CAL	Valid Calendar. If cleared then indicates that invalid entry occurred when writing to Calendar Register.	0x1
0	R	RTC_VALID_TIME	Valid Time. If cleared then indicates that invalid entry occurred when writing to Time Register.	0x1

Table 314: RTC_KEEP_RTC_REG (0x50000430)

Bit	Mode	Symbol	Description	Reset
0	R/W	RTC_KEEP	Keep RTC. When high, the time and calendar registers and any other registers which directly affect or are affected by the time and calendar registers are NOT reset when software reset is applied. When low, the software reset will reset every register except the keep RTC and control registers.	0x1

Table 315: RTC_EVENT_CTRL_REG (0x50000480)

Bit	Mode	Symbol	Description	Reset
1	R/W	RTC_PDC_EVENT_EN	0 = Event to PDC is disabled. No clear any pending event 1 = Even to PDC is enabled	0x0
0	R/W	RTC_MOTOR_EVENT_EN	0 = Event to Motor is disabled 1 = Event to Motor is enabled	0x0

Table 316: **RTC_MOTOR_EVENT_PERIOD_REG (0x50000484)**

Bit	Mode	Symbol	Description	Reset
11:0	R/W	RTC_MOTOR_EVENT_PERIOD	RTC will send an event to motor (if RTC_MOTOR_EVENT_EN=1) every (RTC_MOTOR_EVENT_PERIOD+1)*10ms	0x0

Table 317: **RTC_PDC_EVENT_PERIOD_REG (0x50000488)**

Bit	Mode	Symbol	Description	Reset
12:0	R/W	RTC_PDC_EVENT_PERIOD	RTC will send an event to PDC (if RTC_PDC_EVENT_EN=1) every (RTC_PDC_EVENT_PERIOD+1)*10ms	0x0

Table 318: **RTC_PDC_EVENT_CLEAR_REG (0x5000048C)**

Bit	Mode	Symbol	Description	Reset
0	R	PDC_EVENT_CLEAR	On read, PDC event is cleared	0x0

Table 319: **RTC_MOTOR_EVENT_CNT_REG (0x50000490)**

Bit	Mode	Symbol	Description	Reset
11:0	R	RTC_MOTOR_EVENT_CNT	It gives the current value of the Motor event counter (0 to RTC_MOTOR_EVENT_PERIOD)	0x0

Table 320: **RTC_PDC_EVENT_CNT_REG (0x50000494)**

Bit	Mode	Symbol	Description	Reset
12:0	R	RTC_PDC_EVENT_CNT	It gives the current value of the PDC event counter (0 to RTC_PDC_EVENT_PERIOD)	0x0

42.11 Motor Controller Registers

Table 321: Register map SMOTOR

Address	Register	Description
0x50030E00	SMOTOR_CTRL_REG	Motor control register
0x50030E04	PG0_CTRL_REG	Pattern generator 0 control register
0x50030E08	PG1_CTRL_REG	Pattern generator 1 control register
0x50030E0C	PG2_CTRL_REG	Pattern generator 2 control register
0x50030E10	PG3_CTRL_REG	Pattern generator 3 control register
0x50030E14	PG4_CTRL_REG	Pattern generator 4 control register
0x50030E18	SMOTOR_TRIGGER_REG	Motor controller trigger register
0x50030E20	SMOTOR_CMD_FIFO_REG	Motor control command FIFO register

Address	Register	Description
0x50030E24	SMOTOR_CMD_READ_PTR_REG	Command read pointer register
0x50030E28	SMOTOR_CMD_WRITE_PTR_REG	Command write pointer register
0x50030E2C	SMOTOR_STATUS_REG	Motor controller status register
0x50030E30	SMOTOR_IRQ_CLEAR_REG	Motor control IRQ clear register
0x50030E40	WAVETABLE_BASE	Base address of the wavetable
0x50030E80	CMD_TABLE_BASE	Base address of the command table

Table 322: SMOTOR_CTRL_REG (0x50030E00)

Bit	Mode	Symbol	Description	Reset
28	R/W	TRIG_RTC_EVENT_EN	0 = RTC event does not trigger command pop 1 = RTC event triggers command pop	0x0
27	R/W	MC_LP_CLK_TRIG_EN	0 = Divided sleep clock does not trigger command pop 1 = Divided sleep clock triggers command pop	0x0
26	R/W	SMOTOR_THRESHOLD_IRQ_EN	IRQ in the event of the FIFO level (write pointer - read pointer) reaching, or is below the threshold determined by SMOTOR_THRESHOLD. 0 = Interrupt requests disabled 1 = Interrupt requests enabled	0x0
25:21	R/W	SMOTOR_THRESHOLD_LD	Determines the FIFO level (write pointer - read pointer) at or below which and IRQ can be triggered using SMOTOR_THRESHOLD_IRQ_EN.	0x0
20	R/W	SMOTOR_FIFO_UNR_IRQ_EN	IRQ in the event of FIFO underrun: 0 = Interrupt requests disabled 1 = Interrupt requests enabled	0x0
19	R/W	SMOTOR_FIFO_OVF_IRQ_EN	IRQ in the event of FIFO overflow: 0 = Interrupt requests disabled 1 = Interrupt requests enabled	0x0
18	R/W	SMOTOR_GENEND_IRQ_EN	IRQ in the event a pattern generator (configured to do so through its corresponding GENEND_IRQ_EN bit) has ended generating a pattern: 0 = Interrupt requests disabled 1 = Interrupt requests enabled	0x0
17	R/W	SMOTOR_GENSTART_IRQ_EN	IRQ in the event a pattern generator (configured to do so through its corresponding GENSTART_IRQ_EN bit) has just started generating a pattern: 0 = Interrupt requests disabled 1 = Interrupt requests enabled	0x0
16:7	R/W	SMOTOR_MOI	Idle time of a PG after generating a waveform. A PG will remain busy for the last signal's MOI to finish.	0x0
6:1	R/W	CYCLIC_SIZE	Depth of the cyclic buffer, only valid if CYCLIC_MODE is 1.	0x0
0	R/W	CYCLIC_MODE	Determines operation mode of command FIFO: 0 = Normal FIFO mode	0x0

Bit	Mode	Symbol	Description	Reset
			1 = Cyclic buffer mode, CYCLIC_SIZE determines buffer depth	

Table 323: **PG0_CTRL_REG (0x50030E04)**

Bit	Mode	Symbol	Description	Reset
15	R/W	GENEND_IRQ_EN	Determines if the corresponding pattern generator will contribute to the generation of the IRQ when it is done generating a pattern. It is only valid if SMOTOR_GENEND_IRQ_EN is enabled: 0 = Interrupt requests disabled 1 = Interrupt requests enabled	0x0
14	R/W	GENSTART_IRQ_EN	Determines if the corresponding pattern generator will contribute to the generation of the IRQ when it starts generating a pattern. It is only valid if SMOTOR_GENSTART_IRQ_EN is enabled: 0 = Interrupt requests disabled 1 = Interrupt requests enabled	0x0
13	R/W	PG_START_MODE	0 = Auto start mode: pattern generator will start whenever all enabled signals have received a command 1 = Manual start mode: pattern generator will only start if it has been given a PG_START, and all enabled signals have received a command	0x0
12	R/W	PG_MODE	0 = Flex mode 1 = Pair mode	0x0
11	R/W	SIG3_EN	0 = Signal disabled 1 = Signal enabled	0x1
10	R/W	SIG2_EN	0 = Signal disabled 1 = Signal enabled	0x1
9	R/W	SIG1_EN	0 = Signal disabled 1 = Signal enabled	0x1
8	R/W	SIG0_EN	0 = Signal disabled 1 = Signal enabled	0x1
7:6	R/W	OUT3_SIG	Selects which signal is routed to the output.	0x3
5:4	R/W	OUT2_SIG	Selects which signal is routed to the output.	0x2
3:2	R/W	OUT1_SIG	Selects which signal is routed to the output.	0x1
1:0	R/W	OUT0_SIG	Selects which signal is routed to the output.	0x0

Table 324: **PG1_CTRL_REG (0x50030E08)**

Bit	Mode	Symbol	Description	Reset
15	R/W	GENEND_IRQ_EN	Determines if the corresponding pattern generator will contribute to the generation of the IRQ when it is done generating a pattern. It is only valid if SMOTOR_GENEND_IRQ_EN is enabled: 0 = Interrupt requests disabled 1 = Interrupt requests enabled	0x0

Bit	Mode	Symbol	Description	Reset
14	R/W	GENSTART_IRQ_EN	Determines if the corresponding pattern generator will contribute to the generation of the IRQ when it starts generating a pattern. It is only valid if SMOTOR_GENSTART_IRQ_EN is enabled: 0 = Interrupt requests disabled 1 = Interrupt requests enabled	0x0
13	R/W	PG_START_MODE	0 = Auto start mode: pattern generator will start whenever all enabled signals have received a command 1 = Manual start mode: pattern generator will only start if it has been given a PG_START, and all enabled signals have received a command	0x0
12	R/W	PG_MODE	0 = Flex mode 1 = Pair mode	0x0
11	R/W	SIG3_EN	0 = Signal disabled 1 = Signal enabled	0x1
10	R/W	SIG2_EN	0 = Signal disabled 1 = Signal enabled	0x1
9	R/W	SIG1_EN	0 = Signal disabled 1 = Signal enabled	0x1
8	R/W	SIG0_EN	0 = Signal disabled 1 = Signal enabled	0x1
7:6	R/W	OUT3_SIG	Selects which signal is routed to the output.	0x3
5:4	R/W	OUT2_SIG	Selects which signal is routed to the output.	0x2
3:2	R/W	OUT1_SIG	Selects which signal is routed to the output.	0x1
1:0	R/W	OUT0_SIG	Selects which signal is routed to the output.	0x0

Table 325: PG2_CTRL_REG (0x50030E0C)

Bit	Mode	Symbol	Description	Reset
15	R/W	GENEND_IRQ_EN	Determines if the corresponding pattern generator will contribute to the generation of the IRQ when it is done generating a pattern. It is only valid if SMOTOR_GENEND_IRQ_EN is enabled: 0 = Interrupt requests disabled 1 = Interrupt requests enabled	0x0
14	R/W	GENSTART_IRQ_EN	Determines if the corresponding pattern generator will contribute to the generation of the IRQ when it starts generating a pattern. It is only valid if SMOTOR_GENSTART_IRQ_EN is enabled: 0 = Interrupt requests disabled 1 = Interrupt requests enabled	0x0
13	R/W	PG_START_MODE	0 = Auto start mode: pattern generator will start whenever all enabled signals have received a command 1 = Manual start mode: pattern generator will only start if it has been given a PG_START, and all enabled signals have received a command	0x0
12	R/W	PG_MODE	0 = Flex mode 1 = Pair mode	0x0

Bit	Mode	Symbol	Description	Reset
11	R/W	SIG3_EN	0 = Signal disabled 1 = Signal enabled	0x1
10	R/W	SIG2_EN	0 = Signal disabled 1 = Signal enabled	0x1
9	R/W	SIG1_EN	0 = Signal disabled 1 = Signal enabled	0x1
8	R/W	SIG0_EN	0 = Signal disabled 1 = Signal enabled	0x1
7:6	R/W	OUT3_SIG	Selects which signal is routed to the output.	0x3
5:4	R/W	OUT2_SIG	Selects which signal is routed to the output.	0x2
3:2	R/W	OUT1_SIG	Selects which signal is routed to the output.	0x1
1:0	R/W	OUT0_SIG	Selects which signal is routed to the output.	0x0

Table 326: PG3_CTRL_REG (0x50030E10)

Bit	Mode	Symbol	Description	Reset
15	R/W	GENEND_IRQ_EN	Determines if the corresponding pattern generator will contribute to the generation of the IRQ when it is done generating a pattern. It is only valid if SMOTOR_GENEND_IRQ_EN is enabled: 0 = Interrupt requests disabled 1 = Interrupt requests enabled	0x0
14	R/W	GENSTART_IRQ_EN	Determines if the corresponding pattern generator will contribute to the generation of the IRQ when it starts generating a pattern. It is only valid if SMOTOR_GENSTART_IRQ_EN is enabled: 0 = Interrupt requests disabled 1 = Interrupt requests enabled	0x0
13	R/W	PG_START_MODE	0 = Auto start mode: pattern generator will start whenever all enabled signals have received a command 1 = Manual start mode: pattern generator will only start if it has been given a PG_START, and all enabled signals have received a command	0x0
12	R/W	PG_MODE	0 = Flex mode 1 = Pair mode	0x0
11	R/W	SIG3_EN	0 = Signal disabled 1 = Signal enabled	0x1
10	R/W	SIG2_EN	0 = Signal disabled 1 = Signal enabled	0x1
9	R/W	SIG1_EN	0 = Signal disabled 1 = Signal enabled	0x1
8	R/W	SIG0_EN	0 = Signal disabled 1 = Signal enabled	0x1
7:6	R/W	OUT3_SIG	Selects which signal is routed to the output.	0x3
5:4	R/W	OUT2_SIG	Selects which signal is routed to the output.	0x2
3:2	R/W	OUT1_SIG	Selects which signal is routed to the output.	0x1

Bit	Mode	Symbol	Description	Reset
1:0	R/W	OUT0_SIG	Selects which signal is routed to the output.	0x0

Table 327: PG4_CTRL_REG (0x50030E14)

Bit	Mode	Symbol	Description	Reset
15	R/W	GENEND_IRQ_EN	Determines if the corresponding pattern generator will contribute to the generation of the IRQ when it is done generating a pattern. It is only valid if SMOTOR_GENEND_IRQ_EN is enabled: 0 = Interrupt requests disabled 1 = Interrupt requests enabled	0x0
14	R/W	GENSTART_IRQ_EN	Determines if the corresponding pattern generator will contribute to the generation of the IRQ when it starts generating a pattern. It is only valid if SMOTOR_GENSTART_IRQ_EN is enabled: 0 = Interrupt requests disabled 1 = Interrupt requests enabled	0x0
13	R/W	PG_START_MODE	0 = Auto start mode: pattern generator will start whenever all enabled signals have received a command 1 = Manual start mode: pattern generator will only start if it has been given a PG_START, and all enabled signals have received a command	0x0
12	R/W	PG_MODE	0 = Flex mode 1 = Pair mode	0x0
11	R/W	SIG3_EN	0 = Signal disabled 1 = Signal enabled	0x1
10	R/W	SIG2_EN	0 = Signal disabled 1 = Signal enabled	0x1
9	R/W	SIG1_EN	0 = Signal disabled 1 = Signal enabled	0x1
8	R/W	SIG0_EN	0 = Signal disabled 1 = Signal enabled	0x1
7:6	R/W	OUT3_SIG	Selects which signal is routed to the output.	0x3
5:4	R/W	OUT2_SIG	Selects which signal is routed to the output.	0x2
3:2	R/W	OUT1_SIG	Selects which signal is routed to the output.	0x1
1:0	R/W	OUT0_SIG	Selects which signal is routed to the output.	0x0

Table 328: SMOTOR_TRIGGER_REG (0x50030E18)

Bit	Mode	Symbol	Description	Reset
5	R0/W	PG4_START	Writing 1 to this bit will start PG4, only effective in manual mode.	0x0
4	R0/W	PG3_START	Writing 1 to this bit will start PG3, only effective in manual mode.	0x0
3	R0/W	PG2_START	Writing 1 to this bit will start PG2, only effective in manual mode.	0x0
2	R0/W	PG1_START	Writing 1 to this bit will start PG1, only effective in manual mode.	0x0

Bit	Mode	Symbol	Description	Reset
1	R0/W	PG0_START	Writing 1 to this bit will start PG0, only effective in manual mode.	0x0
0	R0/W	POP_CMD	Writing 1 will pop one (or more, depending on the N_CMDs field of the first) command(s) from the command buffer into its corresponding pattern generator.	0x0

Table 329: SMOTOR_CMD_FIFO_REG (0x50030E20)

Bit	Mode	Symbol	Description	Reset
15:0	W	SMOTOR_CMD_FIFO	Writing to this address will push a command into the command FIFO.	0x0

Table 330: SMOTOR_CMD_READ_PTR_REG (0x50030E24)

Bit	Mode	Symbol	Description	Reset
5:0	R	SMOTOR_CMD_READ_PTR	Pointer to the next command to be popped from the FIFO. The command at SMOTOR_CMD_READ_PTR-1 is the last command that has been popped from the FIFO into its corresponding PG.	0x0

Table 331: SMOTOR_CMD_WRITE_PTR_REG (0x50030E28)

Bit	Mode	Symbol	Description	Reset
5:0	R/W	SMOTOR_CMD_WRITE_PTR	Pointer to the location in the FIFO where the next command will be pushed at. The last command pushed to the FIFO is at SMOTOR_CMD_WRITE_PTR - 1. Can only be changed in cyclic mode	0x0

Table 332: SMOTOR_STATUS_REG (0x50030E2C)

Bit	Mode	Symbol	Description	Reset
9	R	PG4_BUSY	Tells whether the PG is busy/generating a waveform.	0x0
8	R	PG3_BUSY	Tells whether the PG is busy/generating a waveform.	0x0
7	R	PG2_BUSY	Tells whether the PG is busy/generating a waveform.	0x0
6	R	PG1_BUSY	Tells whether the PG is busy/generating a waveform.	0x0
5	R	PG0_BUSY	Tells whether the PG is busy/generating a waveform.	0x0
4	R	THRESHOLD_IRQ_STATUS	Tells whether the THRESHOLD_IRQ fired. Can be cleared with corresponding _CLEAR bit.	0x0
3	R	FIFO_UNR_IRQ_STATUS	Tells whether the FIFO_UNR_IRQ fired. Can be cleared with corresponding _CLEAR bit.	0x0
2	R	FIFO_OVF_IRQ_STATUS	Tells whether the FIFO_OVF_IRQ fired. Can be cleared with corresponding _CLEAR bit.	0x0
1	R	GENEND_IRQ_STATUS	Tells whether the GENEND_IRQ fired. Can be cleared with corresponding _CLEAR bit.	0x0
0	R	GENSTART_IRQ_STATUS	Tells whether the GENSTART_IRQ fired. Can be cleared with corresponding _CLEAR bit.	0x0

Table 333: **SMOTOR_IRQ_CLEAR_REG** (0x50030E30)

Bit	Mode	Symbol	Description	Reset
4	R0/W	THRESHOLD_IRQ_CLEAR	Clears the THRESHOLD_IRQ_STATUS bit.	0x0
3	R0/W	FIFO_UNR_IRQ_CLEAR	Clears the FIFO_UNR_IRQ_STATUS bit.	0x0
2	R0/W	FIFO_OVF_IRQ_CLEAR	Clears the FIFO_OVF_IRQ_STATUS bit.	0x0
1	R0/W	GENEND_IRQ_CLEAR	Clears the GENEND_IRQ_STATUS bit.	0x0
0	R0/W	GENSTART_IRQ_CLEAR	Clears the GENSTART_IRQ_STATUS bit.	0x0

Table 334: **WAVETABLE_BASE** (0x50030E40)

Bit	Mode	Symbol	Description	Reset
28:24	R/W	-	Reserved	0x0
20:16	R/W	-	Reserved	0x0
12:8	R/W	-	Reserved	0x0
4:0	R/W	-	Reserved	0x0

Table 335: **CMD_TABLE_BASE** (0x50030E80)

Bit	Mode	Symbol	Description	Reset
31:0	R	-	Reserved	N/A

42.12 Sensor Node Controller Registers

Table 336: Register map SNC

Address	Register	Description
0x50020C00	SNC_CTRL_REG	Sensor Node Control Register
0x50020C04	SNC_STATUS_REG	Sensor Node Status Register
0x50020C08	SNC_LP_TIMER_REG	Sensor Node Low-Power Timer Register
0x50020C0C	SNC_PC_REG	Sensor Node Program Counter
0x50020C10	SNC_R1_REG	Sensor Node core - Operand 1 Register
0x50020C14	SNC_R2_REG	Sensor Node core - Operand 2 Register
0x50020C18	SNC_TMP1_REG	Sensor Node core - Temporary Register 1
0x50020C1C	SNC_TMP2_REG	Sensor Node core - Temporary Register 2

Table 337: **SNC_CTRL_REG** (0x50020C00)

Bit	Mode	Symbol	Description	Reset
31:9	R	-	Reserved	0x0

Bit	Mode	Symbol	Description	Reset
8	R/W	SNC_IRQ_ACK	<p>When set, the specific bit-field auto-clears the SNC_IRQ_EN field, if the latter is already set. By this way, the IRQ line towards either the CM33 and/or the PDC is cleared. Hence, the CM33 should set this bit-field as soon as it captures the interrupt from the Sensor Node.</p> <p>Note: Any SW writes to this bit-field will be discarded if the SNC_IRQ_EN bit-field is not set. It is finally noted that the SNC_IRQ_ACK bit-field is also auto-clear and it is de-asserted together with SNC_IRQ_EN.</p>	0x0
7:6	R/W	SNC_IRQ_CONFIG	<p>The specific bit-field determines if the IRQ line of the Sensor Node will be routed towards either the host processor (CM33) or the Power Domains Controller (PDC), or to both of them, according to the following configuration:</p> <p>0x0 = Neither the CM33 nor the PDC are triggered, both IRQ lines are low regardless of the value of SNC_IRQ_EN bit-field.</p> <p>0x1 = CM33 should be triggered, provided that SNC_IRQ_EN is set</p> <p>0x2 = PDC should be triggered, provided that SNC_IRQ_EN is set</p> <p>0x3 = Both CM33 and PDC should be triggered, provided that SNC_IRQ_EN is set</p> <p>Note: It must be noted that the specific bit-field is locked after set the SNC_IRQ_EN field of the same register. Hence, the SNC IRQ configuration cannot be changed after the IRQ bit-field is set and before the IRQ is acknowledged (by CM33). It is also noted that after having set SNC_IRQ_EN via SW, the specific bit-field can be de-asserted only by setting the SNC_IRQ_ACK bit-field (see also the description of this bit-field, also residing in SNC_CTRL_REG).</p>	0x0
5	R/W	SNC_IRQ_EN	<p>When set, the specific bit-field may generate a (level-sensitive) IRQ to trigger either the host processor (CM33) or the Power Domains Controller (PDC) or both, depending on the configuration set in the SNC_IRQ_CONFIG bit-field of SNC_CTRL_REG. As soon as the SNC_IRQ_EN is set, it can be cleared only by setting the SNC_IRQ_ACK bit-field.</p>	0x0
4	R/W	SNC_BRANCH_LOOP_INIT	<p>When set, it clears the value of the counter used in the Sensor Node's branch command (COBR), when performing an iterative branch of up to 128 times. This bit-field is auto-cleared with the next SNC clock.</p>	0x0
3	R/W	SNC_RESET	<p>This is the Sensor Node Controller's synchronous clear bit-field. When set, it resets the state of the Sensor Node Controller and sets back its program counter (SNC_PC_REG) to the programmed base address, as determined by SNC_BASE_REG register (located in memory controller). This bit-field is auto-cleared with the next SNC clock.</p> <p>Note: Setting this bit-field may interrupt the Sensor Node's regular execution and any command currently being executed may be abnormally terminated.</p>	0x0
2	R/W	BUS_ERROR_DETECT_EN	<p>When set, it enables the detection of system bus errors that may occur in case a non-mapped address is used</p>	0x0

Bit	Mode	Symbol	Description	Reset
			by the Sensor Node controller, when performing a register access. Note: In case of a bus error detection, the Sensor Node will set to '1' the BUS_ERROR_STATUS bit-field of SNC_STATUS_REG and will continue normally to the next command.	
1	R/W	SNC_SW_CTRL	When set, this bit-field bypasses the enable of Sensor Node that comes from the PDC. In this mode, the Sensor Node can be started and stopped via the SNC_EN bit-field of SNC_CTRL_REG. Note: This mode is suggested to be used for debugging purposes. Also, the base address of the Sensor Node should have been programmed to the target value, before this bit-field is set.	0x0
0	R/W	SNC_EN	Sensor Node Controller's enable bit-field. When set, it may activate the Sensor Node, provided that the SNC_SW_CTRL bit-field is also set. If not, then the specific bit-field is not effective and Sensor Node's actual enable is controller by the Power Domains Controller (PDC). Note: When SNC_SW_CTRL bit-field is set, the Sensor Node is controlled by the user. Thus, in that mode, it can be started and stopped by setting and resetting the SNC_EN field. When SNC_EN is reset, the Sensor Node will first complete the last on-going command before being halted.	0x0

Table 338: SNC_STATUS_REG (0x50020C04)

Bit	Mode	Symbol	Description	Reset
31:7	R	-	Reserved	0x0
6	R	SNC_PC_LOADED	0 : Sensor node's program counter is controlled by the Sensor Node's FSM, incremented by 4 after the fetching of each 32-bit command word. 1 : Sensor node's program counter is loaded with a new value. The assertion of this signal requires the Sensor Node to have been first stopped, so the user must first check that the SNC_IS_STOPPED bit-field of this register is asserted, before writing the program counter. The SNC_PC_LOADED bit-field is auto-clear and it is reset to '0' as soon as the user has re-started the Sensor Node. Note: To start and stop the Sensor Node manually, the SNC_SW_CTRL and SNC_EN bit-fields of SNC_CTRL_REG must have been set by the user. This mode of operation is bypassing the Power Domains Controller and it is to be used for debugging purposes.	0x0
5	R	SNC_IS_STOPPED	0 : Sensor Node is operational and its FSM is running. 1 : Sensor Node is stopped and its FSM is halted. To leave this state, the SNC_EN bit-field of SNC_CTRL_REG must be set, provided that the SNC_SW_CTRL bit-field of the same register is also set. This mode is used for debugging purposes, bypassing the enable of SNC coming from the Power Domains Controller.	0x1

Bit	Mode	Symbol	Description	Reset
			Note: The SNC_PC_REG register can be modified by SW if and only if the SNC_IS_STOPPED bit is set. Otherwise, the writes to SNC_PC_REG are discarded.	
4	R	HARD_FAULT_STAT US	<p>0 : No opcode error has occurred, Sensor Node continues normally.</p> <p>1 : An opcode error has occurred. Sensor Node will continue its execution, but will set also the specific bit-field to '1', for debugging purposes.</p> <p>Note: After being set, this bit-field will be cleared only when the Sensor Node is re-initialized, by starting again from its base address. The latter can happen either by activating the SNC_RESET bit-field of SNC_CTRL_REG or by stopping and starting again the Sensor Node. This is possible only when the PDC is bypassed, so when the Sensor Node is controlled by SNC_EN and SNC_SW_CTRL bit-fields of SNC_CTRL_REG.</p>	0x0
3	R	BUS_ERROR_STATU S	<p>0 : No system bus error detected, Sensor Node continues normally</p> <p>1 : Bus error occurred. Sensor Node will continue, but it will also set the specific flag, which can be used for debugging purposes.</p> <p>Note: This bit-field will be reset to '0' only when the Sensor Node is re-initialized, by starting again from its base address.</p>	0x0
2	R	SNC_DONE_STATUS	<p>0 : Sensor Node has not yet completed the target program's execution.</p> <p>1 : Sensor Node has completed the target program's execution. Together with the update of the status bit, a pulse is also generated to notify the PDC that the Sensor Node is done.</p> <p>Note: This bit-field is set only when the "SLP" (sleep) command is executed, which should be issued after the completion of all pending tasks of the Sensor Node. It will be reset to '0' only when the Sensor Node re-starts, by executing from the base address.</p> <p>This can be done by either toggling (de-asserting and re-asserting again) the SNC_EN bit-field of SNC_CTRL_REG, if the SNC is controlled by SW, or by just re-setting the SNC state via the SNC_RESET bit-field of the same register.</p>	0x0
1	R/W	GR_FLAG	<p>Sensor Node's 'GR' (greater) flag. It can be modified either by the Sensor Node's core (by executing an "RDCGR" command) or by the Sensor Node's microcode, when the latter directly modifies the specific bit-field of SNC_STATUS_REG.</p> <p>When the Sensor Node's FSM is in its initial state (which may happen either by switching-on the PD_COM power domain or by resetting the Sensor Node via SNC_CTRL_REG.SNC_RESET), the specific bit-field is kept to '0', for initialization purposes.</p> <p>When the Sensor Node is stopped and then reset, the Sensor Node's FSM is not in its initial state and in that case, the GR_FLAG bit-field should be reset by the user (if the application needs this to be initialized to '0'). Otherwise, it can be left as it is, until being updated by the Sensor Node itself (upon executing an "RDCGR" command).</p>	0x0

Bit	Mode	Symbol	Description	Reset
			In general, however, this bit-field should not be modified by either the host processor (CM33) or the CMAC processor (CM0+), and especially when the Sensor Node is enabled and operational.	
0	R/W	EQ_FLAG	<p>Sensor Node's 'EQ' (equalhigh) flag. It can be modified either by the Sensor Node's core (by executing an "RDCBI" command) or by the Sensor Node's microcode, when the latter directly modifies the specific bit-field of SNC_STATUS_REG.</p> <p>When the Sensor Node's FSM is in its initial state (which may happen either by switching-on the PD_COM power domain or by resetting the Sensor Node via SNC_CTRL_REG.SNC_RESET), the specific bit-field is kept to '0', for initialization purposes.</p> <p>When the Sensor Node is stopped and then reset, the Sensor Node's FSM is not in its initial state and in that case, the EQ_FLAG bit-field should be reset by the user (if the application needs this to be initialized to '0'). Otherwise, it can be left as it is, until being updated by the Sensor Node itself (upon executing an "RDCBI" command).</p> <p>In general, however, this bit-field should not be modified by either the host processor (CM33) or the CMAC processor (CM0+), and especially when the Sensor Node is enabled and operational.</p>	0x0

Table 339: SNC_LP_TIMER_REG (0x50020C08)

Bit	Mode	Symbol	Description	Reset
31:8	R	-	Reserved	0x0
7:0	R	LP_TIMER	This bit-field returns the current value of the Sensor Node's 8-bit timer, running with the low-power clock and may be used for debugging purposes. The specific timer is used to implement a delay of up to 256 ticks of the low-power clock.	0x0

Table 340: SNC_PC_REG (0x50020C0C)

Bit	Mode	Symbol	Description	Reset
31:19	R	-	Reserved	0x400
18:2	R/W	PC_REG	<p>This bit-field returns the Sensor Node's program counter bits [18:2], which at the same time is the program counter's offset from the starting address of SYSRAM (0x20.000.000), and it is can be set by the user, as soon as Sensor Node has been stopped.</p> <p>The 13 MSBs of the program counter are tied to '0x400', since the Sensor Node always executes from SYSRAM, while its 2 LSBs are always tied to '0', since memory accesses are always of 32-bit.</p> <p>NOTE: The Sensor Node can be stopped by clearing the SNC_EN bit-field of SNC_CTRL_REG and provided that the Power Domains Controller (PDC) is bypassed. The latter can be done by setting to '1' the SNC_SW_CTRL bit-field of SNC_CTRL_REG.</p>	0x0

Bit	Mode	Symbol	Description	Reset
1:0	R	-	Reserved	0x0

Table 341: **SNC_R1_REG** (0x50020C10)

Bit	Mode	Symbol	Description	Reset
31:0	R	R1_REG	Returns the current value of the first 32-bit of the last SNC command executed.	0x0

Table 342: **SNC_R2_REG** (0x50020C14)

Bit	Mode	Symbol	Description	Reset
31:0	R	R2_REG	Returns the current value of the second 32-bit word of the last SNC command executed. This is useful for the SNC commands composed by two 32-bit words.	0x0

Table 343: **SNC_TMP1_REG** (0x50020C18)

Bit	Mode	Symbol	Description	Reset
31:0	R	TMP1_REG	Returns the current value of the Sensor Node's first temporary register. To be used for debugging purposes.	0x0

Table 344: **SNC_TMP2_REG** (0x50020C1C)

Bit	Mode	Symbol	Description	Reset
31:0	R	TMP2_REG	Returns the current value of the Sensor Node's second temporary register. To be used for debugging purposes.	0x0

42.13 SPI Controller Registers

Table 345: Register map SPI

Address	Register	Description
0x50020300	SPI_CTRL_REG	SPI control register 0
0x50020304	SPI_RX_TX_REG	SPI RX/TX register0
0x50020308	SPI_CLEAR_INT_REG	SPI clear interrupt register
0x50020400	SPI2_CTRL_REG	SPI control register 0
0x50020404	SPI2_RX_TX_REG	SPI RX/TX register0
0x50020408	SPI2_CLEAR_INT_REG	SPI clear interrupt register

Table 346: **SPI_CTRL_REG** (0x50020300)

Bit	Mode	Symbol	Description	Reset
31:26	-	-	Reserved	0x0
25	R/W	SPI_TX_FIFO_NOTFU LL_MASK	When 1, SPI Interrupt is generated when TX fifo is not full	0x0

Bit	Mode	Symbol	Description	Reset
24	R/W	SPI_DMA_TXREQ_MODE	In case SPI_FIFO_MODE=3 0 = DMA TX request is generated when transaction is finished 1 = DMA TX request is generated when tx buffer is free	0x0
23	R	SPI_TX_FIFO_EMPTY	0 = Transmit fifo is not empty 1 = Transmit fifo is empty	0x1
22	R	SPI_RX_FIFO_FULL	0 = Receive fifo is not full 1 = Receive fifo is full	0x0
21	R	SPI_RX_FIFO_EMPTY	0 = Receive fifo is not empty 1 = Receive fifo is empty	0x1
20	R/W	SPI_9BIT_VAL	Determines the value of the first bit in 9 bits SPI mode.	0x0
19	R	SPI_BUSY	0 = The SPI is not busy with a transfer. This means that either no TX-data is available or that the transfers have been suspended due to a full RX-FIFO. The SPI_CTRL_REG[SPI_INT_BIT] can be used to distinguish between these situations. 1 = The SPI is busy with a transfer.	0x0
18	R/W	SPI_PRIORITY	0 = The SPI has low priority, the DMA request signals are reset after the corresponding acknowledge. 1 = The SPI has high priority, DMA request signals remain active until the FIFOS are filled/emptied, so the DMA holds the AHB bus.	0x0
17:16	R/W	SPI_FIFO_MODE	0 = TX-FIFO and RX-FIFO used (Bidirectional mode). 1 = RX-FIFO used (Read Only Mode) TX-FIFO single depth, no flow control 2 = TX-FIFO used (Write Only Mode), RX-FIFO single depth, no flow control 3 = No FIFOs used (backwards compatible mode)	0x3
15	R/W	SPI_EN_CTRL	0 = SPI_EN pin disabled in slave mode. Pin SPI_EN is don't care. 1 = SPI_EN pin enabled in slave mode.	0x0
14	R/W	SPI_MINT	0 = Disable SPI_INT_BIT to ICU 1 = Enable SPI_INT_BIT to ICU.	0x0
13	R	SPI_INT_BIT	0 = RX Register or FIFO is empty. 1 = SPI interrupt. Data has been transmitted and received. Must be reset by SW by writing to SPI_CLEAR_INT_REG.	0x0
12	R	SPI_DI	Returns the actual value of pin SPI_DIN (delayed with two internal SPI clock cycles)	0x0
11	R	SPI_TXH	0 = TX-FIFO is not full, data can be written. 1 = TX-FIFO is full, data can not be written.	0x0
10	R/W	SPI_FORCE_DO	0 = normal operation 1 = Force SPIDO output level to value of SPI_DO.	0x0
9:8	R/W	SPI_WORD	00 = 8 bits mode 01 = 16 bit mode 10 = 32 bits mode 11 = 9 bits mode. Only valid in master mode.	0x0

Bit	Mode	Symbol	Description	Reset
7	R/W	SPI_RST	0 = normal operation 1 = Reset SPI. Same function as SPI_ON except that internal clock remain active.	0x0
6	R/W	SPI_SMN	Master/slave mode 0 = Master 1 = Slave	0x0
5	R/W	SPI_DO	Pin SPI_DO output level when SPI is idle or when SPI_FORCE_DO=1	0x0
4:3	R/W	SPI_CLK	Select SPI_CLK clock output frequency in master mode: 00 = SPI_CLK / 8 01 = SPI_CLK / 4 10 = SPI_CLK / 2 11 = SPI_CLK / 14	0x0
2	R/W	SPI_POL	Select SPI_CLK polarity. 0 = SPI_CLK is initially low. 1 = SPI_CLK is initially high.	0x0
1	R/W	SPI_PHA	Select SPI_CLK phase. See functional timing diagrams in SPI chapter	0x0
0	R/W	SPI_ON	0 = SPI Module switched off (power saving). Everything is reset except SPI_CTRL_REG. When this bit is cleared the SPI will remain active in master mode until the shift register and holding register are both empty. 1 = SPI Module switched on. Should only be set after all control bits have their desired values. So two writes are needed!	0x0

Table 347: SPI_RX_TX_REG (0x50020304)

Bit	Mode	Symbol	Description	Reset
31:0	R0/W	SPI_DATA	Write: SPI_TX_REG output register 0 (TX-FIFO) Read: SPI_RX_REG input register 0 (RX-FIFO) In 8 or 9 bits mode bits 31 to 8 are not used, they contain old data. In 16 bits mode bits 31 to 16 are not used, they contain old data.	0x0

Table 348: SPI_CLEAR_INT_REG (0x50020308)

Bit	Mode	Symbol	Description	Reset
31:0	R0/W	SPI_CLEAR_INT	Writing any value to this register will clear the SPI_CTRL_REG[SPI_INT_BIT] Reading returns 0.	0x0

Table 349: SPI2_CTRL_REG (0x50020400)

Bit	Mode	Symbol	Description	Reset
31:26	-	-	Reserved	0x0

Bit	Mode	Symbol	Description	Reset
25	R/W	SPI_TX_FIFO_NOTFULL_MASK	When 1, SPI Interrupt is generated when TX fifo is not full	0x0
24	R/W	SPI_DMA_TXREQ_MODE	In case SPI_FIFO_MODE=3 0 = DMA TX request is generated when transaction is finished 1 = DMA TX request is generated when tx buffer is free	0x0
23	R	SPI_TX_FIFO_EMPTY	0 = Transmit fifo is not empty 1 = Transmit fifo is empty	0x1
22	R	SPI_RX_FIFO_FULL	0 = Receive fifo is not full 1 = Receive fifo is full	0x0
21	R	SPI_RX_FIFO_EMPTY	0 = Receive fifo is not empty 1 = Receive fifo is empty	0x1
20	R/W	SPI_9BIT_VAL	Determines the value of the first bit in 9 bits SPI mode.	0x0
19	R	SPI_BUSY	0 = The SPI is not busy with a transfer. This means that either no TX-data is available or that the transfers have been suspended due to a full RX-FIFO. The SPI_CTRL_REG[SPI_INT_BIT] can be used to distinguish between these situations. 1 = The SPI is busy with a transfer.	0x0
18	R/W	SPI_PRIORITY	0 = The SPI has low priority, the DMA request signals are reset after the corresponding acknowledge. 1 = The SPI has high priority, DMA request signals remain active until the FIFOS are filled/emptied, so the DMA holds the AHB bus.	0x0
17:16	R/W	SPI_FIFO_MODE	0 = TX-FIFO and RX-FIFO used (Bidirectional mode). 1 = RX-FIFO used (Read Only Mode) TX-FIFO single depth, no flow control 2 = TX-FIFO used (Write Only Mode), RX-FIFO single depth, no flow control 3 = No FIFOs used (backwards compatible mode)	0x3
15	R/W	SPI_EN_CTRL	0 = SPI_EN pin disabled in slave mode. Pin SPI_EN is don't care. 1 = SPI_EN pin enabled in slave mode.	0x0
14	R/W	SPI_MINT	0 = Disable SPI_INT_BIT to ICU 1 = Enable SPI_INT_BIT to ICU.	0x0
13	R	SPI_INT_BIT	0 = RX Register or FIFO is empty. 1 = SPI interrupt. Data has been transmitted and received. Must be reset by SW by writing to SPI_CLEAR_INT_REG.	0x0
12	R	SPI_DI	Returns the actual value of pin SPI_DIN (delayed with two internal SPI clock cycles)	0x0
11	R	SPI_TXH	0 = TX-FIFO is not full, data can be written. 1 = TX-FIFO is full, data can not be written.	0x0
10	R/W	SPI_FORCE_DO	0 = normal operation 1 = Force SPIDO output level to value of SPI_DO.	0x0
9:8	R/W	SPI_WORD	00 = 8 bits mode 01 = 16 bit mode	0x0

Bit	Mode	Symbol	Description	Reset
			10 = 32 bits mode 11 = 9 bits mode. Only valid in master mode.	
7	R/W	SPI_RST	0 = normal operation 1 = Reset SPI. Same function as SPI_ON except that internal clock remain active.	0x0
6	R/W	SPI_SMN	Master/slave mode 0 = Master 1 = Slave	0x0
5	R/W	SPI_DO	Pin SPI_DO output level when SPI is idle or when SPI_FORCE_DO=1	0x0
4:3	R/W	SPI_CLK	Select SPI_CLK clock output frequency in master mode: 00 = SPI_CLK / 8 01 = SPI_CLK / 4 10 = SPI_CLK / 2 11 = SPI_CLK / 14	0x0
2	R/W	SPI_POL	Select SPI_CLK polarity. 0 = SPI_CLK is initially low. 1 = SPI_CLK is initially high.	0x0
1	R/W	SPI_PHA	Select SPI_CLK phase. See functional timing diagrams in SPI chapter	0x0
0	R/W	SPI_ON	0 = SPI Module switched off (power saving). Everything is reset except SPI_CTRL_REG. When this bit is cleared the SPI will remain active in master mode until the shift register and holding register are both empty. 1 = SPI Module switched on. Should only be set after all control bits have their desired values. So two writes are needed!	0x0

Table 350: SPI2_RX_TX_REG (0x50020404)

Bit	Mode	Symbol	Description	Reset
31:0	R0/W	SPI_DATA	Write: SPI_TX_REG output register 0 (TX-FIFO) Read: SPI_RX_REG input register 0 (RX-FIFO) In 8 or 9 bits mode bits 31 to 8 are not used, they contain old data. In 16 bits mode bits 31 to 16 are not used, they contain old data.	0x0

Table 351: SPI2_CLEAR_INT_REG (0x50020408)

Bit	Mode	Symbol	Description	Reset
31:0	R0/W	SPI_CLEAR_INT	Writing any value to this register will clear the SPI_CTRL_REG[SPI_INT_BIT] Reading returns 0.	0x0

42.14 Timers Registers

Table 352: Register map Timer1

Address	Register	Description
0x50010200	TIMER_CTRL_REG	Timer control register
0x50010204	TIMER_TIMER_VAL_REG	Timer counter value
0x50010208	TIMER_STATUS_REG	Timer status register
0x5001020C	TIMER_GPIO1_CONF_REG	Timer gpio1 selection
0x50010210	TIMER_GPIO2_CONF_REG	Timer gpio2 selection
0x50010214	TIMER_RELOAD_REG	Timer reload value and Delay in shot mode
0x50010218	TIMER_SHOTWIDTH_REG	Timer Shot duration in shot mode
0x5001021C	TIMER_PRESCALER_REG	Timer prescaler value
0x50010220	TIMER_CAPTURE_GPIO1_REG	Timer value for event on GPIO1
0x50010224	TIMER_CAPTURE_GPIO2_REG	Timer value for event on GPIO2
0x50010228	TIMER_PRESCALER_VAL_REG	Timer prescaler counter value
0x5001022C	TIMER_PWM_FREQ_REG	Timer pwm frequency register
0x50010230	TIMER_PWM_DC_REG	Timer pwm dc register
0x50010234	TIMER_GPIO3_CONF_REG	Timer gpio3 selection
0x50010238	TIMER_GPIO4_CONF_REG	Timer gpio4 selection
0x5001023C	TIMER_CAPTURE_GPIO3_REG	Timer value for event on GPIO1
0x50010240	TIMER_CAPTURE_GPIO4_REG	Timer value for event on GPIO1
0x50010244	TIMER_CLEAR_GPIO_EVENT_REG	Timer clear gpio event register
0x50010248	TIMER_CLEAR_IRQ_REG	Timer clear interrupt
0x50010300	TIMER2_CTRL_REG	Timer control register
0x50010304	TIMER2_TIMER_VAL_REG	Timer counter value
0x50010308	TIMER2_STATUS_REG	Timer status register
0x5001030C	TIMER2_GPIO1_CONF_REG	Timer gpio1 selection
0x50010310	TIMER2_GPIO2_CONF_REG	Timer gpio2 selection
0x50010314	TIMER2_RELOAD_REG	Timer reload value and Delay in shot mode
0x50010318	TIMER2_SHOTWIDTH_REG	Timer Shot duration in shot mode

Multi-Core Bluetooth 5.2 SoC Family with System PMU

Address	Register	Description
0x5001031C	TIMER2_PRESCALER_REG	Timer prescaler value
0x50010320	TIMER2_CAPTURE_GPIO1_REG	Timer value for event on GPIO1
0x50010324	TIMER2_CAPTURE_GPIO2_REG	Timer value for event on GPIO2
0x50010328	TIMER2_PRESCALER_VAL_REG	Timer prescaler counter value
0x5001032C	TIMER2_PWM_FREQ_REG	Timer pwm frequency register
0x50010330	TIMER2_PWM_DC_REG	Timer pwm dc register
0x50010334	TIMER2_CLEAR_IRQ_REG	Timer clear interrupt
0x50040A00	TIMER3_CTRL_REG	Timer control register
0x50040A04	TIMER3_TIMER_VAL_REG	Timer counter value
0x50040A08	TIMER3_STATUS_REG	Timer status register
0x50040A0C	TIMER3_GPIO1_CONF_REG	Timer gpio1 selection
0x50040A10	TIMER3_GPIO2_CONF_REG	Timer gpio2 selection
0x50040A14	TIMER3_RELOAD_REG	Timer reload value and Delay in shot mode
0x50040A1C	TIMER3_PRESCALER_REG	Timer prescaler value
0x50040A20	TIMER3_CAPTURE_GPIO1_REG	Timer value for event on GPIO1
0x50040A24	TIMER3_CAPTURE_GPIO2_REG	Timer value for event on GPIO2
0x50040A28	TIMER3_PRESCALER_VAL_REG	Timer prescaler counter value
0x50040A2C	TIMER3_PWM_FREQ_REG	Timer pwm frequency register
0x50040A30	TIMER3_PWM_DC_REG	Timer pwm dc register
0x50040A34	TIMER3_CLEAR_IRQ_REG	Timer clear interrupt
0x50040B00	TIMER4_CTRL_REG	Timer control register
0x50040B04	TIMER4_TIMER_VAL_REG	Timer counter value
0x50040B08	TIMER4_STATUS_REG	Timer status register
0x50040B0C	TIMER4_GPIO1_CONF_REG	Timer gpio1 selection
0x50040B10	TIMER4_GPIO2_CONF_REG	Timer gpio2 selection
0x50040B14	TIMER4_RELOAD_REG	Timer reload value and Delay in shot mode
0x50040B1C	TIMER4_PRESCALER_REG	Timer prescaler value

Address	Register	Description
0x50040B20	TIMER4_CAPTURE_GPIO1_REG	Timer value for event on GPIO1
0x50040B24	TIMER4_CAPTURE_GPIO2_REG	Timer value for event on GPIO2
0x50040B28	TIMER4_PRESCALER_VAL_REG	Timer prescaler counter value
0x50040B2C	TIMER4_PWM_FREQ_REG	Timer pwm frequency register
0x50040B30	TIMER4_PWM_DC_REG	Timer pwm dc register
0x50040B34	TIMER4_CLEAR_IRQ_REG	Timer clear interrupt

Table 353: TIMER_CTRL_REG (0x50010200)

Bit	Mode	Symbol	Description	Reset
31:15	-	-	Reserved	0x0
14	R/W	TIM_CAP_GPIO4_IRQ_EN	0 = Event on GPIO4 does not create a CAPTIM interrupt 1 = Event on GPIO4 creates a CAPTIM interrupt	0x0
13	R/W	TIM_CAP_GPIO3_IRQ_EN	0 = Event on GPIO3 does not create a CAPTIM interrupt 1 = Event on GPIO3 creates a CAPTIM interrupt	0x0
12	R/W	TIM_CAP_GPIO2_IRQ_EN	0 = Event on GPIO2 does not create a CAPTIM interrupt 1 = Event on GPIO2 creates a CAPTIM interrupt	0x0
11	R/W	TIM_CAP_GPIO1_IRQ_EN	0 = Event on GPIO1 does not create a CAPTIM interrupt 1 = Event on GPIO1 creates a CAPTIM interrupt	0x0
10	R/W	TIM_IN4_EVENT_FALL_EN	Event input 4 edge type 1 = falling edge 0 = rising edge	0x0
9	R/W	TIM_IN3_EVENT_FALL_EN	Event input 3 edge type 1 = falling edge 0 = rising edge	0x0
8	R/W	TIM_CLK_EN	Timer clock enable 1 = clock enabled 0 = clock disabled	0x0
7	R/W	TIM_SYS_CLK_EN	Select clock 1 = Timer uses the DIVN clock 0 = Timer uses the Ip clock	0x0
6	R/W	TIM_FREE_RUN_MODE_EN	Valid when timer counts up, if it is '1' timer does not zero when reaches to reload value. it becomes zero only when it reaches the max value.	0x0
5	R/W	TIM_IRQ_EN	Interrupt mask 1 = timer IRQ is unmasked 0 = timer IRQ is masked	0x0

Bit	Mode	Symbol	Description	Reset
4	R/W	TIM_IN2_EVENT_FALL_EN	Event input 2 edge type 1 = falling edge 0 = rising edge	0x0
3	R/W	TIM_IN1_EVENT_FALL_EN	Event input 1 edge type 1 = falling edge 0 = rising edge	0x0
2	R/W	TIM_COUNT_DOWN_EN	Timer count direction 1 = down 0 = up	0x0
1	R/W	TIM_ONESHOT_MODE_EN	Timer mode 1 = One shot enabled 0 = Counter enabled	0x0
0	R/W	TIM_EN	Timer enable 1 = On 0 = Off	0x0

Table 354: **TIMER_TIMER_VAL_REG (0x50010204)**

Bit	Mode	Symbol	Description	Reset
31:24	-	-	Reserved	0x0
23:0	R	TIM_TIMER_VALUE	Gives the current timer value	0x0

Table 355: **TIMER_STATUS_REG (0x50010208)**

Bit	Mode	Symbol	Description	Reset
31:8	-	-	Reserved	0x0
7	R	TIM_GPIO4_EVENT_PENDING	When 1, GPIO4 event is pending.	0x0
6	R	TIM_GPIO3_EVENT_PENDING	When 1, GPIO3 event is pending.	0x0
5	R	TIM_GPIO2_EVENT_PENDING	When 1, GPIO2 event is pending.	0x0
4	R	TIM_GPIO1_EVENT_PENDING	When 1, GPIO1 event is pending.	0x0
3:2	R	TIM_ONESHOT_PHASE	OneShot phase 0 = Wait for event 1 = Delay phase 2 = Start Shot 3 = Shot phase	0x0
1	R	TIM_IN2_STATE	Gives the logic level of the IN1	0x0
0	R	TIM_IN1_STATE	Gives the logic level of the IN2	0x0

Table 356: **TIMER_GPIO1_CONF_REG (0x5001020C)**

Bit	Mode	Symbol	Description	Reset
31:6	-	-	Reserved	0x0

Bit	Mode	Symbol	Description	Reset
5:0	R/W	TIM_GPIO1_CONF	Select one of the 32 GPIOs as IN1, Valid value 0-32. 1 for the first gpio, 32 for the last gpio. 0 Disable input	0x0

Table 357: **TIMER_GPIO2_CONF_REG** (0x50010210)

Bit	Mode	Symbol	Description	Reset
31:6	-	-	Reserved	0x0
5:0	R/W	TIM_GPIO2_CONF	Select one of the 32 GPIOs as IN2, Valid value 0-32. 1 for the first gpio, 32 for the last gpio. 0 Disable input	0x0

Table 358: **TIMER_RELOAD_REG** (0x50010214)

Bit	Mode	Symbol	Description	Reset
31:24	-	-	Reserved	0x0
23:0	R/W	TIM_RELOAD	Reload or max value in timer mode, Delay phase duration in oneshot mode. Actual delay is the register value plus synchronization time (3 clock cycles)	0x0

Table 359: **TIMER_SHOTWIDTH_REG** (0x50010218)

Bit	Mode	Symbol	Description	Reset
31:24	-	-	Reserved	0x0
23:0	R/W	TIM_SHOTWIDTH	Shot phase duration in oneshot mode	0x0

Table 360: **TIMER_PRESCALER_REG** (0x5001021C)

Bit	Mode	Symbol	Description	Reset
31:5	-	-	Reserved	0x0
4:0	R/W	TIM_PRESCALER	Defines the timer count frequency. CLOCK frequency / (TIM_PRESCALER+1)	0x0

Table 361: **TIMER_CAPTURE_GPIO1_REG** (0x50010220)

Bit	Mode	Symbol	Description	Reset
31:24	-	-	Reserved	0x0
23:0	R	TIM_CAPTURE_GPIO 1	Gives the Capture time for event on GPIO1	0x0

Table 362: **TIMER_CAPTURE_GPIO2_REG** (0x50010224)

Bit	Mode	Symbol	Description	Reset
31:24	-	-	Reserved	0x0
23:0	R	TIM_CAPTURE_GPIO 2	Gives the Capture time for event on GPIO2	0x0

Table 363: **TIMER_PRESCALER_VAL_REG** (0x50010228)

Bit	Mode	Symbol	Description	Reset
31:5	-	-	Reserved	0x0
4:0	R	TIM_PRESCALER_VAL	Gives the current prescaler counter value	0x0

Table 364: **TIMER_PWM_FREQ_REG** (0x5001022C)

Bit	Mode	Symbol	Description	Reset
31:16	-	-	Reserved	0x0
15:0	R/W	TIM_PWM_FREQ	Defines the PWM frequency. Timer clock frequency / (TIM_PWM_FREQ+1) Timer clock is clock after prescaler	0x0

Table 365: **TIMER_PWM_DC_REG** (0x50010230)

Bit	Mode	Symbol	Description	Reset
31:16	-	-	Reserved	0x0
15:0	R/W	TIM_PWM_DC	Defines the PWM duty cycle. TIM_PWM_DC / (TIM_PWM_FREQ+1)	0x0

Table 366: **TIMER_GPIO3_CONF_REG** (0x50010234)

Bit	Mode	Symbol	Description	Reset
31:6	-	-	Reserved	0x0
5:0	R/W	TIM_GPIO3_CONF	Select one of the 32 GPIOs as IN3, Valid value 0-32. 1 for the first gpio, 32 for the last gpio. 0 Disable input	0x0

Table 367: **TIMER_GPIO4_CONF_REG** (0x50010238)

Bit	Mode	Symbol	Description	Reset
31:6	-	-	Reserved	0x0
5:0	R/W	TIM_GPIO4_CONF	Select one of the 32 GPIOs as IN4, Valid value 0-32. 1 for the first gpio, 32 for the last gpio. 0 Disable input	0x0

Table 368: **TIMER_CAPTURE_GPIO3_REG** (0x5001023C)

Bit	Mode	Symbol	Description	Reset
31:24	-	-	Reserved	0x0
23:0	R	TIM_CAPTURE_GPIO3	Gives the Capture time for event on GPIO3	0x0

Table 369: **TIMER_CAPTURE_GPIO4_REG** (0x50010240)

Bit	Mode	Symbol	Description	Reset
31:24	-	-	Reserved	0x0

Bit	Mode	Symbol	Description	Reset
23:0	R	TIM_CAPTURE_GPIO4	Gives the Capture time for event on GPIO4	0x0

Table 370: **TIMER_CLEAR_GPIO_EVENT_REG (0x50010244)**

Bit	Mode	Symbol	Description	Reset
3	R0/W	TIM_CLEAR_GPIO4_EVENT	1 = Clear GPIO4 event. Return always 0	0x0
2	R0/W	TIM_CLEAR_GPIO3_EVENT	1 = Clear GPIO3 event. Return always 0	0x0
1	R0/W	TIM_CLEAR_GPIO2_EVENT	1 = Clear GPIO2 event. Return always 0	0x0
0	R0/W	TIM_CLEAR_GPIO1_EVENT	1 = Clear GPIO1 event. Return always 0	0x0

Table 371: **TIMER_CLEAR_IRQ_REG (0x50010248)**

Bit	Mode	Symbol	Description	Reset
0	R0/W	TIM_CLEAR_IRQ	Write any value clear interrupt	0x0

Table 372: **TIMER2_CTRL_REG (0x50010300)**

Bit	Mode	Symbol	Description	Reset
31:9	-	-	Reserved	0x0
8	R/W	TIM_CLK_EN	Timer clock enable 1 = clock enabled 0 = clock disabled	0x0
7	R/W	TIM_SYS_CLK_EN	Select clock 1 = Timer uses the DIVN clock 0 = Timer uses the Ip clock	0x0
6	R/W	TIM_FREE_RUN_MODE_EN	Valid when timer counts up, if it is '1' timer does not zero when reaches to reload value. it becomes zero only when it reaches the max value.	0x0
5	R/W	TIM_IRQ_EN	Interrupt mask 1 = timer IRQ is unmasked 0 = timer IRQ is masked	0x0
4	R/W	TIM_IN2_EVENT_FALL_EN	Event input 2 edge type 1 = falling edge 0 = rising edge	0x0
3	R/W	TIM_IN1_EVENT_FALL_EN	Event input 1 edge type 1 = falling edge 0 = rising edge	0x0
2	R/W	TIM_COUNT_DOWN_EN	Timer count direction 1 = down 0 = up	0x0
1	R/W	TIM_ONESHOT_MODE_EN	Timer mode 1 = One shot enabled	0x0

Bit	Mode	Symbol	Description	Reset
			0 = Counter enabled	
0	R/W	TIM_EN	Timer enable 1 = On 0 = Off	0x0

Table 373: **TIMER2_TIMER_VAL_REG (0x50010304)**

Bit	Mode	Symbol	Description	Reset
31:24	-	-	Reserved	0x0
23:0	R	TIM_TIMER_VALUE	Gives the current timer value	0x0

Table 374: **TIMER2_STATUS_REG (0x50010308)**

Bit	Mode	Symbol	Description	Reset
31:4	-	-	Reserved	0x0
3:2	R	TIM_ONESHOT_PHASE	OneShot phase 0 = Wait for event 1 = Delay phase 2 = Start Shot 3 = Shot phase	0x0
1	R	TIM_IN2_STATE	Gives the logic level of the IN1	0x0
0	R	TIM_IN1_STATE	Gives the logic level of the IN2	0x0

Table 375: **TIMER2_GPIO1_CONF_REG (0x5001030C)**

Bit	Mode	Symbol	Description	Reset
31:6	-	-	Reserved	0x0
5:0	R/W	TIM_GPIO1_CONF	Select one of the 32 GPIOs as IN1, Valid value 0-32. 1 for the first gpio, 32 for the last gpio. 0 Disable input	0x0

Table 376: **TIMER2_GPIO2_CONF_REG (0x50010310)**

Bit	Mode	Symbol	Description	Reset
31:6	-	-	Reserved	0x0
5:0	R/W	TIM_GPIO2_CONF	Select one of the 32 GPIOs as IN2, Valid value 0-32. 1 for the first gpio, 32 for the last gpio. 0 Disable input	0x0

Table 377: **TIMER2_RELOAD_REG (0x50010314)**

Bit	Mode	Symbol	Description	Reset
31:24	-	-	Reserved	0x0
23:0	R/W	TIM_RELOAD	Reload or max value in timer mode, Delay phase duration in oneshot mode. Actual delay is the register value plus synchronization time (3 clock cycles)	0x0

Table 378: **TIMER2_SHOTWIDTH_REG (0x50010318)**

Bit	Mode	Symbol	Description	Reset
31:24	-	-	Reserved	0x0
23:0	R/W	TIM_SHOTWIDTH	Shot phase duration in oneshot mode	0x0

Table 379: **TIMER2_PRESCALER_REG (0x5001031C)**

Bit	Mode	Symbol	Description	Reset
31:5	-	-	Reserved	0x0
4:0	R/W	TIM_PRESCALER	Defines the timer count frequency. $CLOCK \text{ frequency} / (TIM_PRESCALER+1)$	0x0

Table 380: **TIMER2_CAPTURE_GPIO1_REG (0x50010320)**

Bit	Mode	Symbol	Description	Reset
31:24	-	-	Reserved	0x0
23:0	R	TIM_CAPTURE_GPIO 1	Gives the Capture time for event on GPIO1	0x0

Table 381: **TIMER2_CAPTURE_GPIO2_REG (0x50010324)**

Bit	Mode	Symbol	Description	Reset
31:24	-	-	Reserved	0x0
23:0	R	TIM_CAPTURE_GPIO 2	Gives the Capture time for event on GPIO2	0x0

Table 382: **TIMER2_PRESCALER_VAL_REG (0x50010328)**

Bit	Mode	Symbol	Description	Reset
31:5	-	-	Reserved	0x0
4:0	R	TIM_PRESCALER_VAL	Gives the current prescaler counter value	0x0

Table 383: **TIMER2_PWM_FREQ_REG (0x5001032C)**

Bit	Mode	Symbol	Description	Reset
31:16	-	-	Reserved	0x0
15:0	R/W	TIM_PWM_FREQ	Defines the PWM frequency. $Timer \text{ clock frequency} / (TIM_PWM_FREQ+1)$ Timer clock is clock after prescaler	0x0

Table 384: **TIMER2_PWM_DC_REG (0x50010330)**

Bit	Mode	Symbol	Description	Reset
31:16	-	-	Reserved	0x0
15:0	R/W	TIM_PWM_DC	Defines the PWM duty cycle. $TIM_PWM_DC / (TIM_PWM_FREQ+1)$	0x0

Table 385: **TIMER2_CLEAR_IRQ_REG (0x50010334)**

Bit	Mode	Symbol	Description	Reset
0	R/W	TIM_CLEAR_IRQ	Write any value clear interrupt	0x0

Table 386: **TIMER3_CTRL_REG (0x50040A00)**

Bit	Mode	Symbol	Description	Reset
31:9	-	-	Reserved	0x0
8	R/W	TIM_CLK_EN	Timer clock enable 1 = clock enabled 0 = clock disabled	0x0
7	R/W	TIM_SYS_CLK_EN	Select clock 1 = Timer uses the DIVN clock 0 = Timer uses the lp clock	0x0
6	R/W	TIM_FREE_RUN_MODE_EN	Valid when timer counts up, if it is '1' timer does not zero when reaches to reload value. it becomes zero only when it reaches the max value.	0x0
5	R/W	TIM_IRQ_EN	Interrupt mask 1 = timer IRQ is unmasked 0 = timer IRQ is masked	0x0
4	R/W	TIM_IN2_EVENT_FALL_EN	Event input 2 edge type 1 = falling edge 0 = rising edge	0x0
3	R/W	TIM_IN1_EVENT_FALL_EN	Event input 1 edge type 1 = falling edge 0 = rising edge	0x0
2	R/W	TIM_COUNT_DOWN_EN	Timer count direction 1 = down 0 = up	0x0
1	R/W	-	Reserved	0x0
0	R/W	TIM_EN	Timer enable 1 = On 0 = Off	0x0

Table 387: **TIMER3_TIMER_VAL_REG (0x50040A04)**

Bit	Mode	Symbol	Description	Reset
31:24	-	-	Reserved	0x0
23:0	R	TIM_TIMER_VALUE	Gives the current timer value	0x0

Table 388: **TIMER3_STATUS_REG (0x50040A08)**

Bit	Mode	Symbol	Description	Reset
31:4	-	-	Reserved	0x0

Bit	Mode	Symbol	Description	Reset
3:2	R	TIM_ONESHOT_PHASE	OneShot phase 0 = Wait for event 1 = Delay phase 2 = Start Shot 3 = Shot phase	0x0
1	R	TIM_IN2_STATE	Gives the logic level of the IN1	0x0
0	R	TIM_IN1_STATE	Gives the logic level of the IN2	0x0

Table 389: **TIMER3_GPIO1_CONF_REG (0x50040A0C)**

Bit	Mode	Symbol	Description	Reset
31:6	-	-	Reserved	0x0
5:0	R/W	TIM_GPIO1_CONF	Select one of the 32 GPIOs as IN1, Valid value 0-32. 1 for the first gpio, 32 for the last gpio. 0 Disable input	0x0

Table 390: **TIMER3_GPIO2_CONF_REG (0x50040A10)**

Bit	Mode	Symbol	Description	Reset
31:6	-	-	Reserved	0x0
5:0	R/W	TIM_GPIO2_CONF	Select one of the 32 GPIOs as IN2, Valid value 0-32. 1 for the first gpio, 32 for the last gpio. 0 Disable input	0x0

Table 391: **TIMER3_RELOAD_REG (0x50040A14)**

Bit	Mode	Symbol	Description	Reset
31:24	-	-	Reserved	0x0
23:0	R/W	TIM_RELOAD	Reload or max value in timer mode. Actual delay is the register value plus synchronization time (3 clock cycles)	0x0

Table 392: **TIMER3_PRESCALER_REG (0x50040A1C)**

Bit	Mode	Symbol	Description	Reset
31:5	-	-	Reserved	0x0
4:0	R/W	TIM_PRESCALER	Defines the timer count frequency. CLOCK frequency / (TIM_PRESCALER+1)	0x0

Table 393: **TIMER3_CAPTURE_GPIO1_REG (0x50040A20)**

Bit	Mode	Symbol	Description	Reset
31:24	-	-	Reserved	0x0
23:0	R	TIM_CAPTURE_GPIO1	Gives the Capture time for event on GPIO1	0x0

Table 394: **TIMER3_CAPTURE_GPIO2_REG (0x50040A24)**

Bit	Mode	Symbol	Description	Reset
31:24	-	-	Reserved	0x0
23:0	R	TIM_CAPTURE_GPIO2	Gives the Capture time for event on GPIO2	0x0

Table 395: **TIMER3_PRESCALER_VAL_REG (0x50040A28)**

Bit	Mode	Symbol	Description	Reset
31:5	-	-	Reserved	0x0
4:0	R	TIM_PRESCALER_VAL	Gives the current prescaler counter value	0x0

Table 396: **TIMER3_PWM_FREQ_REG (0x50040A2C)**

Bit	Mode	Symbol	Description	Reset
31:16	-	-	Reserved	0x0
15:0	R/W	TIM_PWM_FREQ	Defines the PWM frequency. Timer clock frequency / (TIM_PWM_FREQ+1) Timer clock is clock after prescaler	0x0

Table 397: **TIMER3_PWM_DC_REG (0x50040A30)**

Bit	Mode	Symbol	Description	Reset
31:16	-	-	Reserved	0x0
15:0	R/W	TIM_PWM_DC	Defines the PWM duty cycle. TIM_PWM_DC / (TIM_PWM_FREQ+1)	0x0

Table 398: **TIMER3_CLEAR_IRQ_REG (0x50040A34)**

Bit	Mode	Symbol	Description	Reset
0	R0/W	TIM_CLEAR_IRQ	Write any value clear interrupt	0x0

Table 399: **TIMER4_CTRL_REG (0x50040B00)**

Bit	Mode	Symbol	Description	Reset
31:9	-	-	Reserved	0x0
8	R/W	TIM_CLK_EN	Timer clock enable 1 = clock enabled 0 = clock disabled	0x0
7	R/W	TIM_SYS_CLK_EN	Select clock 1 = Timer uses the DIVN clock 0 = Timer uses the Ip clock	0x0
6	R/W	TIM_FREE_RUN_MODE_EN	Valid when timer counts up, if it is '1' timer does not zero when reaches to reload value. it becomes zero only when it reaches the max value.	0x0
5	R/W	TIM_IRQ_EN	Interrupt mask	0x0

Bit	Mode	Symbol	Description	Reset
			1 = timer IRQ is unmasked 0 = timer IRQ is masked	
4	R/W	TIM_IN2_EVENT_FALL_EN	Event input 2 edge type 1 = falling edge 0 = rising edge	0x0
3	R/W	TIM_IN1_EVENT_FALL_EN	Event input 1 edge type 1 = falling edge 0 = rising edge	0x0
2	R/W	TIM_COUNT_DOWN_EN	Timer count direction 1 = down 0 = up	0x0
1	R/W	-	Reserved	0x0
0	R/W	TIM_EN	Timer enable 1 = On 0 = Off	0x0

Table 400: **TIMER4_TIMER_VAL_REG (0x50040B04)**

Bit	Mode	Symbol	Description	Reset
31:24	-	-	Reserved	0x0
23:0	R	TIM_TIMER_VALUE	Gives the current timer value	0x0

Table 401: **TIMER4_STATUS_REG (0x50040B08)**

Bit	Mode	Symbol	Description	Reset
31:4	-	-	Reserved	0x0
3:2	R	TIM_ONESHOT_PHASE	OneShot phase 0 = Wait for event 1 = Delay phase 2 = Start Shot 3 = Shot phase	0x0
1	R	TIM_IN2_STATE	Gives the logic level of the IN1	0x0
0	R	TIM_IN1_STATE	Gives the logic level of the IN2	0x0

Table 402: **TIMER4_GPIO1_CONF_REG (0x50040B0C)**

Bit	Mode	Symbol	Description	Reset
31:6	-	-	Reserved	0x0
5:0	R/W	TIM_GPIO1_CONF	Select one of the 32 GPIOs as IN1, Valid value 0-32. 1 for the first gpio, 32 for the last gpio. 0 Disable input	0x0

Table 403: **TIMER4_GPIO2_CONF_REG (0x50040B10)**

Bit	Mode	Symbol	Description	Reset
31:6	-	-	Reserved	0x0

Bit	Mode	Symbol	Description	Reset
5:0	R/W	TIM_GPIO2_CONF	Select one of the 32 GPIOs as IN2, Valid value 0-32. 1 for the first gpio, 32 for the last gpio. 0 Disable input	0x0

Table 404: **TIMER4_RELOAD_REG (0x50040B14)**

Bit	Mode	Symbol	Description	Reset
31:24	-	-	Reserved	0x0
23:0	R/W	TIM_RELOAD	Reload or max value in timer mode. Actual delay is the register value plus synchronization time (3 clock cycles)	0x0

Table 405: **TIMER4_PRESCALER_REG (0x50040B1C)**

Bit	Mode	Symbol	Description	Reset
31:5	-	-	Reserved	0x0
4:0	R/W	TIM_PRESCALER	Defines the timer count frequency. CLOCK frequency / (TIM_PRESCALER+1)	0x0

Table 406: **TIMER4_CAPTURE_GPIO1_REG (0x50040B20)**

Bit	Mode	Symbol	Description	Reset
31:24	-	-	Reserved	0x0
23:0	R	TIM_CAPTURE_GPIO 1	Gives the Capture time for event on GPIO1	0x0

Table 407: **TIMER4_CAPTURE_GPIO2_REG (0x50040B24)**

Bit	Mode	Symbol	Description	Reset
31:24	-	-	Reserved	0x0
23:0	R	TIM_CAPTURE_GPIO 2	Gives the Capture time for event on GPIO2	0x0

Table 408: **TIMER4_PRESCALER_VAL_REG (0x50040B28)**

Bit	Mode	Symbol	Description	Reset
31:5	-	-	Reserved	0x0
4:0	R	TIM_PRESCALER_VAL	Gives the current prescaler counter value	0x0

Table 409: **TIMER4_PWM_FREQ_REG (0x50040B2C)**

Bit	Mode	Symbol	Description	Reset
31:16	-	-	Reserved	0x0
15:0	R/W	TIM_PWM_FREQ	Defines the PWM frequency. Timer clock frequency / (TIM_PWM_FREQ+1) Timer clock is clock after prescaler	0x0

Table 410: **TIMER4_PWM_DC_REG** (0x50040B30)

Bit	Mode	Symbol	Description	Reset
31:16	-	-	Reserved	0x0
15:0	R/W	TIM_PWM_DC	Defines the PWM duty cycle. $TIM_PWM_DC / (TIM_PWM_FREQ+1)$	0x0

Table 411: **TIMER4_CLEAR_IRQ_REG** (0x50040B34)

Bit	Mode	Symbol	Description	Reset
0	R0/W	TIM_CLEAR_IRQ	Write any value clear interrupt	0x0

42.15 True Random Number Generator Controller Registers

Table 412: Register map TRNG

Address	Register	Description
0x50040C00	TRNG_CTRL_REG	TRNG control register
0x50040C04	TRNG_FIFOLVL_REG	TRNG FIFO level register
0x50040C08	TRNG_VER_REG	TRNG Version register

Table 413: **TRNG_CTRL_REG** (0x50040C00)

Bit	Mode	Symbol	Description	Reset
31:2	-	-	Reserved	0x0
1	R/W	-	Reserved	0x0
0	R/W	TRNG_ENABLE	0: Disable the TRNG 1: Enable the TRNG this signal is ignored when the FIFO is full	0x0

Table 414: **TRNG_FIFOLVL_REG** (0x50040C04)

Bit	Mode	Symbol	Description	Reset
31:6	-	-	Reserved	0x0
5	R	TRNG_FIFOFULL	1:FIFO full indication. This bit is cleared if the FIFO is read.	0x0
4:0	R	TRNG_FIFOLVL	Number of 32 bit words of random data in the FIFO (max 31) until the FIFO is full. When it is 0 and TRNG_FIFOFULL is 1, it means the FIFO is full.	0x0

Table 415: **TRNG_VER_REG** (0x50040C08)

Bit	Mode	Symbol	Description	Reset
31:24	R	TRNG_MAJ	Major version number	0x0
23:16	R	TRNG_MIN	Minor version number	0x0
15:0	R	TRNG_SVN	SVN revision number	0x103

42.16 UART Registers

Table 416: Register map UART

Address	Register	Description
0x50020000	UART_RBR_THR_DLL_REG	Receive Buffer Register
0x50020004	UART_IER_DLH_REG	Interrupt Enable Register
0x50020008	UART_IIR_FCR_REG	Interrupt Identification Register/FIFO Control Register
0x5002000C	UART_LCR_REG	Line Control Register
0x50020010	UART_MCR_REG	Modem Control Register
0x50020014	UART_LSR_REG	Line Status Register
0x5002001C	UART_SCR_REG	Scratchpad Register
0x50020030	UART_SRBR_STHR0_REG	Shadow Receive/Transmit Buffer Register
0x50020034	UART_SRBR_STHR1_REG	Shadow Receive/Transmit Buffer Register
0x50020038	UART_SRBR_STHR2_REG	Shadow Receive/Transmit Buffer Register
0x5002003C	UART_SRBR_STHR3_REG	Shadow Receive/Transmit Buffer Register
0x50020040	UART_SRBR_STHR4_REG	Shadow Receive/Transmit Buffer Register
0x50020044	UART_SRBR_STHR5_REG	Shadow Receive/Transmit Buffer Register
0x50020048	UART_SRBR_STHR6_REG	Shadow Receive/Transmit Buffer Register
0x5002004C	UART_SRBR_STHR7_REG	Shadow Receive/Transmit Buffer Register
0x50020050	UART_SRBR_STHR8_REG	Shadow Receive/Transmit Buffer Register
0x50020054	UART_SRBR_STHR9_REG	Shadow Receive/Transmit Buffer Register
0x50020058	UART_SRBR_STHR10_REG	Shadow Receive/Transmit Buffer Register
0x5002005C	UART_SRBR_STHR11_REG	Shadow Receive/Transmit Buffer Register
0x50020060	UART_SRBR_STHR12_REG	Shadow Receive/Transmit Buffer Register
0x50020064	UART_SRBR_STHR13_REG	Shadow Receive/Transmit Buffer Register
0x50020068	UART_SRBR_STHR14_REG	Shadow Receive/Transmit Buffer Register
0x5002006C	UART_SRBR_STHR15_REG	Shadow Receive/Transmit Buffer Register
0x5002007C	UART_USR_REG	UART Status register.
0x50020080	UART_TFL_REG	Transmit FIFO Level

Multi-Core Bluetooth 5.2 SoC Family with System PMU

Address	Register	Description
0x50020084	UART_RFL_REG	Receive FIFO Level.
0x50020088	UART_SRR_REG	Software Reset Register.
0x50020090	UART_SBCR_REG	Shadow Break Control Register
0x50020094	UART_SDMAM_REG	Shadow DMA Mode
0x50020098	UART_SFE_REG	Shadow FIFO Enable
0x5002009C	UART_SRT_REG	Shadow RCVR Trigger
0x500200A0	UART_STET_REG	Shadow TX Empty Trigger
0x500200A4	UART_HTX_REG	Halt TX
0x500200A8	UART_DMASA_REG	DMA Software Acknowledge
0x500200C0	UART_DLF_REG	Divisor Latch Fraction Register
0x500200F8	UART_UCV_REG	Component Version
0x500200FC	UART_CTR_REG	Component Type Register
0x50020100	UART2_RBR_THR_DLL_REG	Receive Buffer Register
0x50020104	UART2_IER_DLH_REG	Interrupt Enable Register
0x50020108	UART2_IIR_FCR_REG	Interrupt Identification Register/FIFO Control Register
0x5002010C	UART2_LCR_REG	Line Control Register
0x50020110	UART2_MCR_REG	Modem Control Register
0x50020114	UART2_LSR_REG	Line Status Register
0x50020118	UART2_MSR_REG	Modem Status Register
0x5002011C	UART2_SCR_REG	Scratchpad Register
0x50020130	UART2_SRBR_STHR0_REG	Shadow Receive/Transmit Buffer Register
0x50020134	UART2_SRBR_STHR1_REG	Shadow Receive/Transmit Buffer Register
0x50020138	UART2_SRBR_STHR2_REG	Shadow Receive/Transmit Buffer Register
0x5002013C	UART2_SRBR_STHR3_REG	Shadow Receive/Transmit Buffer Register
0x50020140	UART2_SRBR_STHR4_REG	Shadow Receive/Transmit Buffer Register
0x50020144	UART2_SRBR_STHR5_REG	Shadow Receive/Transmit Buffer Register
0x50020148	UART2_SRBR_STHR6_REG	Shadow Receive/Transmit Buffer Register
0x5002014C	UART2_SRBR_STHR7_REG	Shadow Receive/Transmit Buffer Register
0x50020150	UART2_SRBR_STHR8_REG	Shadow Receive/Transmit Buffer Register
0x50020154	UART2_SRBR_STHR9_REG	Shadow Receive/Transmit Buffer Register
0x50020158	UART2_SRBR_STHR10_REG	Shadow Receive/Transmit Buffer Register
0x5002015C	UART2_SRBR_STHR11_REG	Shadow Receive/Transmit Buffer Register

Multi-Core Bluetooth 5.2 SoC Family with System PMU

Address	Register	Description
0x50020160	UART2_SRBR_STHR12_REG	Shadow Receive/Transmit Buffer Register
0x50020164	UART2_SRBR_STHR13_REG	Shadow Receive/Transmit Buffer Register
0x50020168	UART2_SRBR_STHR14_REG	Shadow Receive/Transmit Buffer Register
0x5002016C	UART2_SRBR_STHR15_REG	Shadow Receive/Transmit Buffer Register
0x5002017C	UART2_USR_REG	UART Status register.
0x50020180	UART2_TFL_REG	Transmit FIFO Level
0x50020184	UART2_RFL_REG	Receive FIFO Level.
0x50020188	UART2_SRR_REG	Software Reset Register.
0x5002018C	UART2_SRTS_REG	Shadow Request to Send
0x50020190	UART2_SBCR_REG	Shadow Break Control Register
0x50020194	UART2_SDMAM_REG	Shadow DMA Mode
0x50020198	UART2_SFE_REG	Shadow FIFO Enable
0x5002019C	UART2_SRT_REG	Shadow RCVR Trigger
0x500201A0	UART2_STET_REG	Shadow TX Empty Trigger
0x500201A4	UART2_HTX_REG	Halt TX
0x500201A8	UART2_DMASA_REG	DMA Software Acknowledge
0x500201C0	UART2_DLF_REG	Divisor Latch Fraction Register
0x500201C4	UART2_RAR_REG	Receive Address Register
0x500201C8	UART2_TAR_REG	Transmit Address Register
0x500201CC	UART2_LCR_EXT	Line Extended Control Register
0x500201F8	UART2_UCV_REG	Component Version
0x500201FC	UART2_CTR_REG	Component Type Register
0x50020200	UART3_RBR_THR_DLL_REG	Receive Buffer Register
0x50020204	UART3_IER_DLH_REG	Interrupt Enable Register
0x50020208	UART3_IIR_FCR_REG	Interrupt Identification Register/FIFO Control Register
0x5002020C	UART3_LCR_REG	Line Control Register
0x50020210	UART3_MCR_REG	Modem Control Register
0x50020214	UART3_LSR_REG	Line Status Register
0x50020218	UART3_MSR_REG	Modem Status Register
0x5002021C	UART3_CONFIG_REG	ISO7816 Config Register
0x50020230	UART3_SRBR_STHR0_REG	Shadow Receive/Transmit Buffer Register
0x50020234	UART3_SRBR_STHR1_REG	Shadow Receive/Transmit Buffer Register
0x50020238	UART3_SRBR_STHR2_REG	Shadow Receive/Transmit Buffer Register
0x5002023C	UART3_SRBR_STHR3_REG	Shadow Receive/Transmit Buffer Register

Multi-Core Bluetooth 5.2 SoC Family with System PMU

Address	Register	Description
0x50020240	UART3_SRBR_STHR4_REG	Shadow Receive/Transmit Buffer Register
0x50020244	UART3_SRBR_STHR5_REG	Shadow Receive/Transmit Buffer Register
0x50020248	UART3_SRBR_STHR6_REG	Shadow Receive/Transmit Buffer Register
0x5002024C	UART3_SRBR_STHR7_REG	Shadow Receive/Transmit Buffer Register
0x50020250	UART3_SRBR_STHR8_REG	Shadow Receive/Transmit Buffer Register
0x50020254	UART3_SRBR_STHR9_REG	Shadow Receive/Transmit Buffer Register
0x50020258	UART3_SRBR_STHR10_REG	Shadow Receive/Transmit Buffer Register
0x5002025C	UART3_SRBR_STHR11_REG	Shadow Receive/Transmit Buffer Register
0x50020260	UART3_SRBR_STHR12_REG	Shadow Receive/Transmit Buffer Register
0x50020264	UART3_SRBR_STHR13_REG	Shadow Receive/Transmit Buffer Register
0x50020268	UART3_SRBR_STHR14_REG	Shadow Receive/Transmit Buffer Register
0x5002026C	UART3_SRBR_STHR15_REG	Shadow Receive/Transmit Buffer Register
0x5002027C	UART3_USR_REG	UART Status register.
0x50020280	UART3_TFL_REG	Transmit FIFO Level
0x50020284	UART3_RFL_REG	Receive FIFO Level.
0x50020288	UART3_SRR_REG	Software Reset Register.
0x5002028C	UART3_SRTS_REG	Shadow Request to Send
0x50020290	UART3_SBCR_REG	Shadow Break Control Register
0x50020294	UART3_SDMAM_REG	Shadow DMA Mode
0x50020298	UART3_SFE_REG	Shadow FIFO Enable
0x5002029C	UART3_SRT_REG	Shadow RCVR Trigger
0x500202A0	UART3_STET_REG	Shadow TX Empty Trigger
0x500202A4	UART3_HTX_REG	Halt TX
0x500202A8	UART3_DMASA_REG	DMA Software Acknowledge
0x500202C0	UART3_DLF_REG	Divisor Latch Fraction Register
0x500202C4	UART3_RAR_REG	Receive Address Register
0x500202C8	UART3_TAR_REG	Transmit Address Register
0x500202CC	UART3_LCR_EXT	Line Extended Control Register
0x500202E0	UART3_CTRL_REG	ISO7816 Control Register
0x500202E4	UART3_TIMER_REG	ISO7816 Timer Register
0x500202E8	UART3_ERR_CTRL_REG	ISO7816 Error Signal Control Register

Address	Register	Description
0x500202EC	UART3_IRQ_STATUS_REG	ISO7816 Interrupt Status Register
0x500202F8	UART3_UCV_REG	Component Version
0x500202FC	UART3_CTR_REG	Component Type Register

Table 417: UART_RBR_THR_DLL_REG (0x50020000)

Bit	Mode	Symbol	Description	Reset
31:8	-	-	Reserved	0x0
7:0	R/W	RBR_THR_DLL	<p>Receive Buffer Register: (RBR).</p> <p>This register contains the data byte received on the serial input port (sin) in UART mode or the serial infrared input (sir_in) in infrared mode. The data in this register is valid only if the Data Ready (DR) bit in the Line status Register (LSR) is set. If FIFOs are disabled (FCR[0] set to zero), the data in the RBR must be read before the next data arrives, otherwise it will be overwritten, resulting in an overrun error. If FIFOs are enabled (FCR[0] set to one), this register accesses the head of the receive FIFO. If the receive FIFO is full and this register is not read before the next data character arrives, then the data already in the FIFO will be preserved but any incoming data will be lost. An overrun error will also occur.</p> <p>Transmit Holding Register: (THR)</p> <p>This register contains data to be transmitted on the serial output port (sout) in UART mode or the serial infrared output (sir_out_n) in infrared mode. Data should only be written to the THR when the THR Empty (THRE) bit (LSR[5]) is set. If FIFO's are disabled (FCR[0] set to zero) and THRE is set, writing a single character to the THR clears the THRE. Any additional writes to the THR before the THRE is set again causes the THR data to be overwritten. If FIFO's are enabled (FCR[0] set to one) and THRE is set, x number of characters of data may be written to the THR before the FIFO is full. The number x (default=16) is determined by the value of FIFO Depth that you set during configuration. Any attempt to write data when the FIFO is full results in the write data being lost.</p> <p>Divisor Latch (Low): (DLL)</p> <p>This register makes up the lower 8-bits of a 16-bit, read/write, Divisor Latch register that contains the baud rate divisor for the UART. This register may only be accessed when the DLAB bit (LCR[7]) is set. The output baud rate is equal to the serial clock (sclk) frequency divided by sixteen times the value of the baud rate divisor, as follows:</p> $\text{baud rate} = (\text{serial clock freq}) / (16 * \text{divisor})$ <p>Note that with the Divisor Latch Registers (DLL and DLH) set to zero, the baud clock is disabled and no serial communications will occur. Also, once the DLL is set, at least 8 clock cycles of the slowest DW_apb_uart clock should be allowed to pass before transmitting or receiving data.</p>	0x0

Bit	Mode	Symbol	Description	Reset
			<p>Divisor Latch (High): (DLH) (Note: This register is placed in UART_IER_DLH_REG with offset 0x4)</p> <p>Upper 8-bits of a 16-bit, read/write, Divisor Latch register that contains the baud rate divisor for the UART. This register may be accessed only when the DLAB bit (LCR[7]) is set. The output baud rate is equal to the serial clock frequency divided by sixteen times the value of the baud rate divisor, as follows:</p> $\text{baud rate} = (\text{serial clock freq}) / (16 * \text{divisor}).$ <p>Note that with the Divisor Latch Registers (DLL and DLH) set to zero, the baud clock is disabled and no serial communications occur. Also, once the DLH is set, at least 8 clock cycles of the slowest DW_apb_uart clock should be allowed to pass before transmitting or receiving data.</p>	

Table 418: UART_IER_DLH_REG (0x50020004)

Bit	Mode	Symbol	Description	Reset
31:8	-	-	Reserved	0x0
7	R/W	PTIME_DLH7	<p>Interrupt Enable Register: PTIME, Programmable THRE Interrupt Mode Enable. This is used to enable/disable the generation of THRE Interrupt. 0 = disabled 1 = enabled</p> <p>Divisor Latch (High): Bit[7] of the 8 bit DLH register.</p>	0x0
6:5	R/W	DLH6_5	Divisor Latch (High): Bit[6:5] of the 8 bit DLH register	0x0
4	R/W	ELCOLR_DLH4	<p>Interrupt Enable Register: (read only) ELCOLR, this bit controls the method for clearing the status in the LSR register. This is applicable only for Overrun Error, Parity Error, Framing Error, and Break Interrupt status bits.</p> <p>Always 0 = LSR status bits are cleared either on reading Rx FIFO (RBR Read) or On reading LSR register.</p> <p>Divisor Latch (High): Bit[4] of the 8 bit DLH register</p>	0x0
3	R/W	EDSSI_DLH3	<p>Interrupt Enable Register: reserved</p> <p>Divisor Latch (High): Bit[3] of the 8 bit DLH register</p>	0x0
2	R/W	ELSI_DLH2	<p>Interrupt Enable Register: ELSI, Enable Receiver Line Status Interrupt. This is used to enable/disable the generation of Receiver Line Status Interrupt. This is the highest priority interrupt. 0 = disabled 1 = enabled</p> <p>Divisor Latch (High): Bit[2] of the 8 bit DLH register.</p>	0x0
1	R/W	ETBEI_DLH1	<p>Interrupt Enable Register: ETBEI, Enable Transmit Holding Register Empty Interrupt. This is used to enable/disable the generation of Transmitter Holding Register Empty Interrupt. This is the third highest priority interrupt. 0 = disabled 1 = enabled</p> <p>Divisor Latch (High): Bit[1] of the 8 bit DLH register.</p>	0x0
0	R/W	ERBFI_DLH0	<p>Interrupt Enable Register: ERBFI, Enable Received Data Available Interrupt. This is used to enable/disable the generation of Received Data Available Interrupt and the Character Timeout Interrupt (if in FIFO mode and FIFO's enabled). These are the second highest priority interrupts. 0 = disabled 1 = enabled</p> <p>Divisor Latch (High): Bit[0] of the 8 bit DLH register.</p>	0x0

Table 419: UART_IIR_FCR_REG (0x50020008)

Bit	Mode	Symbol	Description	Reset
31:8	-	-	Reserved	0x0
7:0	R/W	IIR_FCR	<p>On Read Interrupt Identification Register :</p> <p>Bits[7:6], FIFO's Enabled (or FIFOSE): This is used to indicate whether the FIFO's are enabled or disabled. 00 = disabled. 11 = enabled.</p> <p>Bits[5:4], Reserved</p> <p>Bits[3:0], Interrupt ID (or IID): This indicates the highest priority pending interrupt which can be one of the following types: 0001 = no interrupt pending. 0010 = THR empty. 0100 = received data available. 0110 = receiver line status. 0111 = busy detect. 1100 = character timeout.</p> <p>On Write FIFO Control Register</p> <p>Bits[7:6], RCVR Trigger (or RT):. This is used to select the trigger level in the receiver FIFO at which the Received Data Available Interrupt will be generated. In auto flow control mode it is used to determine when the rts_n signal will be de-asserted. It also determines when the dma_rx_req_n signal will be asserted when in certain modes of operation. The following trigger levels are supported: 00 = 1 character in the FIFO 01 = FIFO 1/4 full 10 = FIFO 1/2 full 11 = FIFO 2 less than full</p> <p>Bits[5:4], TX Empty Trigger (or TET): This is used to select the empty threshold level at which the THRE Interrupts will be generated when the mode is active. It also determines when the dma_tx_req_n signal will be asserted when in certain modes of operation. The following trigger levels are supported: 00 = FIFO empty 01 = 2 characters in the FIFO 10 = FIFO 1/4 full 11 = FIFO 1/2 full</p> <p>Bit[3], DMA Mode (or DMAM): This determines the DMA signalling mode used for the dma_tx_req_n and dma_rx_req_n output signals. 0 = mode 0 1 = mode 1</p> <p>Bit[2], XMIT FIFO Reset (or XFIFOR): This resets the control portion of the transmit FIFO and treats the FIFO as empty. Note that this bit is 'self-clearing' and it is not necessary to clear this bit.</p> <p>Bit[1], RCVR FIFO Reset (or RFIFOR): This resets the control portion of the receive FIFO and treats the FIFO as empty. Note that this bit is 'self-clearing' and it is not necessary to clear this bit.</p> <p>Bit[0], FIFO Enable (or FIFOE): This enables/disables the transmit (XMIT) and receive (RCVR) FIFO's. Whenever the value of this bit is changed both the XMIT and RCVR controller portion of FIFO's will be reset.</p>	0x1

Table 420: UART_LCR_REG (0x5002000C)

Bit	Mode	Symbol	Description	Reset
31:8	-	-	Reserved	0x0
7	R/W	UART_DLAB	<p>Divisor Latch Access Bit.</p> <p>This bit is used to enable reading and writing of the Divisor Latch register (DLL and DLH) to set the baud rate of the UART.</p> <p>This bit must be cleared after initial baud rate setup in order to access other registers.</p>	0x0
6	R/W	UART_BC	<p>Break Control Bit.</p> <p>This is used to cause a break condition to be transmitted to the receiving device. If set to one the serial output is forced to the spacing (logic 0) state. When not in Loopback Mode, as determined by MCR[4], the serial line is forced low until the Break bit is cleared.</p>	0x0
5	-	-	Reserved	0x0
4	R/W	UART_EPS	<p>Even Parity Select. Writeable only when UART is not busy (USR[0] is zero).</p> <p>This is used to select between even and odd parity, when parity is enabled (PEN set to one). If set to one, an even number of logic 1s is transmitted or checked. If set to zero, an odd number of logic 1s is transmitted or checked.</p>	0x0
3	R/W	UART_PEN	<p>Parity Enable. Writeable only when UART is not busy (USR[0] is zero)</p> <p>This bit is used to enable and disable parity generation and detection in transmitted and received serial character respectively.</p> <p>0 = parity disabled 1 = parity enabled</p>	0x0
2	R/W	UART_STOP	<p>Number of stop bits.</p> <p>This is used to select the number of stop bits per character that the peripheral transmits and receives. If set to zero, one stop bit is transmitted in the serial data. If set to one and the data bits are set to 5 (LCR[1:0] set to zero) one and a half stop bits is transmitted. Otherwise, two stop bits are transmitted. Note that regardless of the number of stop bits selected, the receiver checks only the first stop bit.</p> <p>0 = 1 stop bit 1 = 1.5 stop bits when DLS (LCR[1:0]) is zero, else 2 stop bit</p>	0x0
1:0	R/W	UART_DLS	<p>Data Length Select.</p> <p>This is used to select the number of data bits per character that the peripheral transmits and receives. The number of bit that may be selected areas follows:</p> <p>00 = 5 bits 01 = 6 bits 10 = 7 bits 11 = 8 bits</p>	0x0

Table 421: UART_MCR_REG (0x50020010)

Bit	Mode	Symbol	Description	Reset
31:7	-	-	Reserved	0x0
6	R/W	-	Reserved	0x0
5	R/W	-	Reserved	0x0
4	R/W	UART_LB	<p>LoopBack Bit.</p> <p>This is used to put the UART into a diagnostic mode for test purposes.</p> <p>If operating in UART mode (SIR_MODE not active, MCR[6] set to zero), data on the sout line is held high, while serial data output is looped back to the sin line, internally. In this mode all the interrupts are fully functional. Also, in loopback mode, the modem control inputs (dsr_n, cts_n, ri_n, dcd_n) are disconnected and the modem control outputs (dtr_n, rts_n, out1_n, out2_n) are looped back to the inputs, internally.</p> <p>If operating in infrared mode (SIR_MODE active, MCR[6] set to one), data on the sir_out_n line is held low, while serial data output is inverted and looped back to the sir_in line.</p>	0x0
3	R/W	-	Reserved	0x0
2	R/W	-	Reserved	0x0
1	R/W	-	Reserved	0x0
0	R/W	-	Reserved	0x0

Table 422: UART_LSR_REG (0x50020014)

Bit	Mode	Symbol	Description	Reset
31:8	-	-	Reserved	0x0
7	R	UART_RFE	<p>Receiver FIFO Error bit.</p> <p>This bit is only relevant when FIFOs are enabled (FCR[0] set to one). This is used to indicate if there is at least one parity error, framing error, or break indication in the FIFO.</p> <p>0 = no error in RX FIFO 1 = error in RX FIFO</p> <p>This bit is cleared when the LSR is read and the character with the error is at the top of the receiver FIFO and there are no subsequent errors in the FIFO.</p>	0x0
6	R	UART_TEMT	<p>Transmitter Empty bit.</p> <p>If FIFOs enabled (FCR[0] set to one), this bit is set whenever the Transmitter Shift Register and the FIFO are both empty. If FIFOs are disabled, this bit is set whenever the Transmitter Holding Register and the Transmitter Shift Register are both empty.</p>	0x1
5	R	UART_THRE	<p>Transmit Holding Register Empty bit.</p> <p>If THRE mode is disabled (IER[7] set to zero) and regardless of FIFO's being implemented/enabled or not, this bit indicates that the THR or TX FIFO is empty.</p> <p>This bit is set whenever data is transferred from the THR or TX FIFO to the transmitter shift register and no new data has been written to the THR or TX FIFO. This also</p>	0x1

Bit	Mode	Symbol	Description	Reset
			causes a THRE Interrupt to occur, if the THRE Interrupt is enabled. If both modes are active (IER[7] set to one and FCR[0] set to one respectively), the functionality is switched to indicate the transmitter FIFO is full, and no longer controls THRE interrupts, which are then controlled by the FCR[5:4] threshold setting.	
4	R	UART_BI	<p>Break Interrupt bit.</p> <p>This is used to indicate the detection of a break sequence on the serial input data.</p> <p>It is set whenever the serial input, sin, is held in a logic '0' state for longer than the sum of start time + data bits + parity + stop bits.</p> <p>In the FIFO mode, the character associated with the break condition is carried through the FIFO and is revealed when the character is at the top of the FIFO.</p> <p>Reading the LSR clears the BI bit. In the non-FIFO mode, the BI indication occurs immediately and persists until the LSR is read.</p>	0x0
3	R	UART_FE	<p>Framing Error bit.</p> <p>This is used to indicate the occurrence of a framing error in the receiver. A framing error occurs when the receiver does not detect a valid STOP bit in the received data.</p> <p>In the FIFO mode, since the framing error is associated with a character received, it is revealed when the character with the framing error is at the top of the FIFO.</p> <p>When a framing error occurs, the UART tries to resynchronize. It does this by assuming that the error was due to the start bit of the next character and then continues receiving the other bit i.e. data, and/or parity and stop. It should be noted that the Framing Error (FE) bit (LSR[3]) is set if a break interrupt has occurred, as indicated by Break Interrupt (BI) bit (LSR[4]).</p> <p>0 = no framing error 1 = framing error</p> <p>Reading the LSR clears the FE bit.</p>	0x0
2	R	UART_PE	<p>Parity Error bit.</p> <p>This is used to indicate the occurrence of a parity error in the receiver if the Parity Enable (PEN) bit (LCR[3]) is set.</p> <p>In the FIFO mode, since the parity error is associated with a character received, it is revealed when the character with the parity error arrives at the top of the FIFO.</p> <p>It should be noted that the Parity Error (PE) bit (LSR[2]) is set if a break interrupt has occurred, as indicated by Break Interrupt (BI) bit (LSR[4]).</p> <p>0 = no parity error 1 = parity error</p> <p>Reading the LSR clears the PE bit.</p>	0x0
1	R	UART_OE	<p>Overrun error bit.</p> <p>This is used to indicate the occurrence of an overrun error.</p> <p>This occurs if a new data character was received before the previous data was read.</p>	0x0

Bit	Mode	Symbol	Description	Reset
			In the non-FIFO mode, the OE bit is set when a new character arrives in the receiver before the previous character was read from the RBR. When this happens, the data in the RBR is overwritten. In the FIFO mode, an overrun error occurs when the FIFO is full and a new character arrives at the receiver. The data in the FIFO is retained and the data in the receive shift register is lost. 0 = no overrun error 1 = overrun error Reading the LSR clears the OE bit.	
0	R	UART_DR	Data Ready bit. This is used to indicate that the receiver contains at least one character in the RBR or the receiver FIFO. 0 = no data ready 1 = data ready This bit is cleared when the RBR is read in non-FIFO mode, or when the receiver FIFO is empty, in FIFO mode.	0x0

Table 423: **UART_SCR_REG (0x5002001C)**

Bit	Mode	Symbol	Description	Reset
31:8	-	-	Reserved	0x0
7:0	R/W	UART_SCRATCH_PA D	This register is for programmers to use as a temporary storage space. It has no defined purpose in the UART Ctrl.	0x0

Table 424: **UART_SRBR_STHR0_REG (0x50020030)**

Bit	Mode	Symbol	Description	Reset
31:8	-	-	Reserved	0x0
7:0	R/W	SRBR_STHRx	Shadow Receive Buffer Register x: This is a shadow register for the RBR and has been allocated sixteen 32-bit locations so as to accommodate burst accesses from the master. This register contains the data byte received on the serial input port (sin) in UART mode or the serial infrared input (sir_in) in infrared mode. The data in this register is valid only if the Data Ready (DR) bit in the Line status Register (LSR) is set. If FIFOs are disabled (FCR[0] set to zero), the data in the RBR must be read before the next data arrives, otherwise it will be overwritten, resulting in an overrun error. If FIFOs are enabled (FCR[0] set to one), this register accesses the head of the receive FIFO. If the receive FIFO is full and this register is not read before the next data character arrives, then the data already in the FIFO will be preserved but any incoming data will be lost. An overrun error will also occur. Shadow Transmit Holding Register 0: This is a shadow register for the THR and has been allocated sixteen 32-bit locations so as to accommodate burst accesses from the master. This register contains data to be transmitted on the serial output port (sout) in UART mode or the serial infrared output (sir_out_n) in infrared mode. Data should only be written to the THR	0x0

Bit	Mode	Symbol	Description	Reset
			when the THR Empty (THRE) bit (LSR[5]) is set. If FIFO's are disabled (FCR[0] set to zero) and THRE is set, writing a single character to the THR clears the THRE. Any additional writes to the THR before the THRE is set again causes the THR data to be overwritten. If FIFO's are enabled (FCR[0] set to one) and THRE is set, x number of characters of data may be written to the THR before the FIFO is full. The number x (default=16) is determined by the value of FIFO Depth that you set during configuration. Any attempt to write data when the FIFO is full results in the write data being lost.	

Table 425: **UART_SRBR_STHR1_REG (0x50020034)**

Bit	Mode	Symbol	Description	Reset
31:8	-	-	Reserved	0x0
7:0	R/W	SRBR_STHRx	Shadow Receive Buffer Register x: This is a shadow register for the RBR and has been allocated sixteen 32-bit locations so as to accommodate burst accesses from the master. This register contains the data byte received on the serial input port (sin) in UART mode or the serial infrared input (sir_in) in infrared mode. The data in this register is valid only if the Data Ready (DR) bit in the Line status Register (LSR) is set. If FIFOs are disabled (FCR[0] set to zero), the data in the RBR must be read before the next data arrives, otherwise it will be overwritten, resulting in an overrun error. If FIFOs are enabled (FCR[0] set to one), this register accesses the head of the receive FIFO. If the receive FIFO is full and this register is not read before the next data character arrives, then the data already in the FIFO will be preserved but any incoming data will be lost. An overrun error will also occur. Shadow Transmit Holding Register 0: This is a shadow register for the THR and has been allocated sixteen 32-bit locations so as to accommodate burst accesses from the master. This register contains data to be transmitted on the serial output port (sout) in UART mode or the serial infrared output (sir_out_n) in infrared mode. Data should only be written to the THR when the THR Empty (THRE) bit (LSR[5]) is set. If FIFO's are disabled (FCR[0] set to zero) and THRE is set, writing a single character to the THR clears the THRE. Any additional writes to the THR before the THRE is set again causes the THR data to be overwritten. If FIFO's are enabled (FCR[0] set to one) and THRE is set, x number of characters of data may be written to the THR before the FIFO is full. The number x (default=16) is determined by the value of FIFO Depth that you set during configuration. Any attempt to write data when the FIFO is full results in the write data being lost.	0x0

Table 426: **UART_SRBR_STHR2_REG (0x50020038)**

Bit	Mode	Symbol	Description	Reset
31:8	-	-	Reserved	0x0

Bit	Mode	Symbol	Description	Reset
7:0	R/W	SRBR_STHRx	Shadow Receive Buffer Register x: This is a shadow register for the RBR and has been allocated sixteen 32-bit locations so as to accommodate burst accesses from the master. This register contains the data byte received on the serial input port (sin) in UART mode or the serial infrared input (sir_in) in infrared mode. The data in this register is valid only if the Data Ready (DR) bit in the Line status Register (LSR) is set. If FIFOs are disabled (FCR[0] set to zero), the data in the RBR must be read before the next data arrives, otherwise it will be overwritten, resulting in an overrun error. If FIFOs are enabled (FCR[0] set to one), this register accesses the head of the receive FIFO. If the receive FIFO is full and this register is not read before the next data character arrives, then the data already in the FIFO will be preserved but any incoming data will be lost. An overrun error will also occur. Shadow Transmit Holding Register 0: This is a shadow register for the THR and has been allocated sixteen 32-bit locations so as to accommodate burst accesses from the master. This register contains data to be transmitted on the serial output port (sout) in UART mode or the serial infrared output (sir_out_n) in infrared mode. Data should only be written to the THR when the THR Empty (THRE) bit (LSR[5]) is set. If FIFO's are disabled (FCR[0] set to zero) and THRE is set, writing a single character to the THR clears the THRE. Any additional writes to the THR before the THRE is set again causes the THR data to be overwritten. If FIFO's are enabled (FCR[0] set to one) and THRE is set, x number of characters of data may be written to the THR before the FIFO is full. The number x (default=16) is determined by the value of FIFO Depth that you set during configuration. Any attempt to write data when the FIFO is full results in the write data being lost.	0x0

Table 427: **UART_SRBR_STHR3_REG (0x5002003C)**

Bit	Mode	Symbol	Description	Reset
31:8	-	-	Reserved	0x0
7:0	R/W	SRBR_STHRx	Shadow Receive Buffer Register x: This is a shadow register for the RBR and has been allocated sixteen 32-bit locations so as to accommodate burst accesses from the master. This register contains the data byte received on the serial input port (sin) in UART mode or the serial infrared input (sir_in) in infrared mode. The data in this register is valid only if the Data Ready (DR) bit in the Line status Register (LSR) is set. If FIFOs are disabled (FCR[0] set to zero), the data in the RBR must be read before the next data arrives, otherwise it will be overwritten, resulting in an overrun error. If FIFOs are enabled (FCR[0] set to one), this register accesses the head of the receive FIFO. If the receive FIFO is full and this register is not read before the next data character arrives, then the data already in the FIFO will be preserved but any incoming data will be lost. An overrun error will also occur. Shadow Transmit Holding Register 0: This is a shadow register for the THR and has been allocated sixteen 32-bit locations so as to accommodate	0x0

Bit	Mode	Symbol	Description	Reset
			burst accesses from the master. This register contains data to be transmitted on the serial output port (sout) in UART mode or the serial infrared output (sir_out_n) in infrared mode. Data should only be written to the THR when the THR Empty (THRE) bit (LSR[5]) is set. If FIFO's are disabled (FCR[0] set to zero) and THRE is set, writing a single character to the THR clears the THRE. Any additional writes to the THR before the THRE is set again causes the THR data to be overwritten. If FIFO's are enabled (FCR[0] set to one) and THRE is set, x number of characters of data may be written to the THR before the FIFO is full. The number x (default=16) is determined by the value of FIFO Depth that you set during configuration. Any attempt to write data when the FIFO is full results in the write data being lost.	

Table 428: **UART_SRBR_STHR4_REG (0x50020040)**

Bit	Mode	Symbol	Description	Reset
31:8	-	-	Reserved	0x0
7:0	R/W	SRBR_STHRx	Shadow Receive Buffer Register x: This is a shadow register for the RBR and has been allocated sixteen 32-bit locations so as to accommodate burst accesses from the master. This register contains the data byte received on the serial input port (sin) in UART mode or the serial infrared input (sir_in) in infrared mode. The data in this register is valid only if the Data Ready (DR) bit in the Line status Register (LSR) is set. If FIFOs are disabled (FCR[0] set to zero), the data in the RBR must be read before the next data arrives, otherwise it will be overwritten, resulting in an overrun error. If FIFOs are enabled (FCR[0] set to one), this register accesses the head of the receive FIFO. If the receive FIFO is full and this register is not read before the next data character arrives, then the data already in the FIFO will be preserved but any incoming data will be lost. An overrun error will also occur. Shadow Transmit Holding Register 0: This is a shadow register for the THR and has been allocated sixteen 32-bit locations so as to accommodate burst accesses from the master. This register contains data to be transmitted on the serial output port (sout) in UART mode or the serial infrared output (sir_out_n) in infrared mode. Data should only be written to the THR when the THR Empty (THRE) bit (LSR[5]) is set. If FIFO's are disabled (FCR[0] set to zero) and THRE is set, writing a single character to the THR clears the THRE. Any additional writes to the THR before the THRE is set again causes the THR data to be overwritten. If FIFO's are enabled (FCR[0] set to one) and THRE is set, x number of characters of data may be written to the THR before the FIFO is full. The number x (default=16) is determined by the value of FIFO Depth that you set during configuration. Any attempt to write data when the FIFO is full results in the write data being lost.	0x0

Table 429: **UART_SRBR_STHR5_REG (0x50020044)**

Bit	Mode	Symbol	Description	Reset
31:8	-	-	Reserved	0x0
7:0	R/W	SRBR_STHRx	Shadow Receive Buffer Register x: This is a shadow register for the RBR and has been allocated sixteen 32-bit locations so as to accommodate burst accesses from the master. This register contains the data byte received on the serial input port (sin) in UART mode or the serial infrared input (sir_in) in infrared mode. The data in this register is valid only if the Data Ready (DR) bit in the Line status Register (LSR) is set. If FIFOs are disabled (FCR[0] set to zero), the data in the RBR must be read before the next data arrives, otherwise it will be overwritten, resulting in an overrun error. If FIFOs are enabled (FCR[0] set to one), this register accesses the head of the receive FIFO. If the receive FIFO is full and this register is not read before the next data character arrives, then the data already in the FIFO will be preserved but any incoming data will be lost. An overrun error will also occur. Shadow Transmit Holding Register 0: This is a shadow register for the THR and has been allocated sixteen 32-bit locations so as to accommodate burst accesses from the master. This register contains data to be transmitted on the serial output port (sout) in UART mode or the serial infrared output (sir_out_n) in infrared mode. Data should only be written to the THR when the THR Empty (THRE) bit (LSR[5]) is set. If FIFO's are disabled (FCR[0] set to zero) and THRE is set, writing a single character to the THR clears the THRE. Any additional writes to the THR before the THRE is set again causes the THR data to be overwritten. If FIFO's are enabled (FCR[0] set to one) and THRE is set, x number of characters of data may be written to the THR before the FIFO is full. The number x (default=16) is determined by the value of FIFO Depth that you set during configuration. Any attempt to write data when the FIFO is full results in the write data being lost.	0x0

Table 430: **UART_SRBR_STHR6_REG (0x50020048)**

Bit	Mode	Symbol	Description	Reset
31:8	-	-	Reserved	0x0
7:0	R/W	SRBR_STHRx	Shadow Receive Buffer Register x: This is a shadow register for the RBR and has been allocated sixteen 32-bit locations so as to accommodate burst accesses from the master. This register contains the data byte received on the serial input port (sin) in UART mode or the serial infrared input (sir_in) in infrared mode. The data in this register is valid only if the Data Ready (DR) bit in the Line status Register (LSR) is set. If FIFOs are disabled (FCR[0] set to zero), the data in the RBR must be read before the next data arrives, otherwise it will be overwritten, resulting in an overrun error. If FIFOs are enabled (FCR[0] set to one), this register accesses the head of the receive FIFO. If the receive FIFO is full and this register is not read before the next data character arrives, then the data already in the FIFO will be preserved but any incoming data will be lost. An overrun	0x0

Bit	Mode	Symbol	Description	Reset
			error will also occur. Shadow Transmit Holding Register 0: This is a shadow register for the THR and has been allocated sixteen 32-bit locations so as to accommodate burst accesses from the master. This register contains data to be transmitted on the serial output port (sout) in UART mode or the serial infrared output (sir_out_n) in infrared mode. Data should only be written to the THR when the THR Empty (THRE) bit (LSR[5]) is set. If FIFO's are disabled (FCR[0] set to zero) and THRE is set, writing a single character to the THR clears the THRE. Any additional writes to the THR before the THRE is set again causes the THR data to be overwritten. If FIFO's are enabled (FCR[0] set to one) and THRE is set, x number of characters of data may be written to the THR before the FIFO is full. The number x (default=16) is determined by the value of FIFO Depth that you set during configuration. Any attempt to write data when the FIFO is full results in the write data being lost.	

Table 431: **UART_SRBR_STHR7_REG (0x5002004C)**

Bit	Mode	Symbol	Description	Reset
31:8	-	-	Reserved	0x0
7:0	R/W	SRBR_STHRx	Shadow Receive Buffer Register x: This is a shadow register for the RBR and has been allocated sixteen 32-bit locations so as to accommodate burst accesses from the master. This register contains the data byte received on the serial input port (sin) in UART mode or the serial infrared input (sir_in) in infrared mode. The data in this register is valid only if the Data Ready (DR) bit in the Line status Register (LSR) is set. If FIFOs are disabled (FCR[0] set to zero), the data in the RBR must be read before the next data arrives, otherwise it will be overwritten, resulting in an overrun error. If FIFOs are enabled (FCR[0] set to one), this register accesses the head of the receive FIFO. If the receive FIFO is full and this register is not read before the next data character arrives, then the data already in the FIFO will be preserved but any incoming data will be lost. An overrun error will also occur. Shadow Transmit Holding Register 0: This is a shadow register for the THR and has been allocated sixteen 32-bit locations so as to accommodate burst accesses from the master. This register contains data to be transmitted on the serial output port (sout) in UART mode or the serial infrared output (sir_out_n) in infrared mode. Data should only be written to the THR when the THR Empty (THRE) bit (LSR[5]) is set. If FIFO's are disabled (FCR[0] set to zero) and THRE is set, writing a single character to the THR clears the THRE. Any additional writes to the THR before the THRE is set again causes the THR data to be overwritten. If FIFO's are enabled (FCR[0] set to one) and THRE is set, x number of characters of data may be written to the THR before the FIFO is full. The number x (default=16) is determined by the value of FIFO Depth that you set during configuration. Any attempt to write data when the FIFO is full results in the write data being lost.	0x0

Table 432: **UART_SRBR_STHR8_REG (0x50020050)**

Bit	Mode	Symbol	Description	Reset
31:8	-	-	Reserved	0x0
7:0	R/W	SRBR_STHRx	Shadow Receive Buffer Register x: This is a shadow register for the RBR and has been allocated sixteen 32-bit locations so as to accommodate burst accesses from the master. This register contains the data byte received on the serial input port (sin) in UART mode or the serial infrared input (sir_in) in infrared mode. The data in this register is valid only if the Data Ready (DR) bit in the Line status Register (LSR) is set. If FIFOs are disabled (FCR[0] set to zero), the data in the RBR must be read before the next data arrives, otherwise it will be overwritten, resulting in an overrun error. If FIFOs are enabled (FCR[0] set to one), this register accesses the head of the receive FIFO. If the receive FIFO is full and this register is not read before the next data character arrives, then the data already in the FIFO will be preserved but any incoming data will be lost. An overrun error will also occur. Shadow Transmit Holding Register 0: This is a shadow register for the THR and has been allocated sixteen 32-bit locations so as to accommodate burst accesses from the master. This register contains data to be transmitted on the serial output port (sout) in UART mode or the serial infrared output (sir_out_n) in infrared mode. Data should only be written to the THR when the THR Empty (THRE) bit (LSR[5]) is set. If FIFO's are disabled (FCR[0] set to zero) and THRE is set, writing a single character to the THR clears the THRE. Any additional writes to the THR before the THRE is set again causes the THR data to be overwritten. If FIFO's are enabled (FCR[0] set to one) and THRE is set, x number of characters of data may be written to the THR before the FIFO is full. The number x (default=16) is determined by the value of FIFO Depth that you set during configuration. Any attempt to write data when the FIFO is full results in the write data being lost.	0x0

Table 433: **UART_SRBR_STHR9_REG (0x50020054)**

Bit	Mode	Symbol	Description	Reset
31:8	-	-	Reserved	0x0
7:0	R/W	SRBR_STHRx	Shadow Receive Buffer Register x: This is a shadow register for the RBR and has been allocated sixteen 32-bit locations so as to accommodate burst accesses from the master. This register contains the data byte received on the serial input port (sin) in UART mode or the serial infrared input (sir_in) in infrared mode. The data in this register is valid only if the Data Ready (DR) bit in the Line status Register (LSR) is set. If FIFOs are disabled (FCR[0] set to zero), the data in the RBR must be read before the next data arrives, otherwise it will be overwritten, resulting in an overrun error. If FIFOs are enabled (FCR[0] set to one), this register accesses the head of the receive FIFO. If the receive FIFO is full and this register is not read before the next data character	0x0

Bit	Mode	Symbol	Description	Reset
			arrives, then the data already in the FIFO will be preserved but any incoming data will be lost. An overrun error will also occur. Shadow Transmit Holding Register 0: This is a shadow register for the THR and has been allocated sixteen 32-bit locations so as to accommodate burst accesses from the master. This register contains data to be transmitted on the serial output port (sout) in UART mode or the serial infrared output (sir_out_n) in infrared mode. Data should only be written to the THR when the THR Empty (THRE) bit (LSR[5]) is set. If FIFO's are disabled (FCR[0] set to zero) and THRE is set, writing a single character to the THR clears the THRE. Any additional writes to the THR before the THRE is set again causes the THR data to be overwritten. If FIFO's are enabled (FCR[0] set to one) and THRE is set, x number of characters of data may be written to the THR before the FIFO is full. The number x (default=16) is determined by the value of FIFO Depth that you set during configuration. Any attempt to write data when the FIFO is full results in the write data being lost.	

Table 434: **UART_SRBR_STHR10_REG (0x50020058)**

Bit	Mode	Symbol	Description	Reset
31:8	-	-	Reserved	0x0
7:0	R/W	SRBR_STHRx	Shadow Receive Buffer Register x: This is a shadow register for the RBR and has been allocated sixteen 32-bit locations so as to accommodate burst accesses from the master. This register contains the data byte received on the serial input port (sin) in UART mode or the serial infrared input (sir_in) in infrared mode. The data in this register is valid only if the Data Ready (DR) bit in the Line status Register (LSR) is set. If FIFOs are disabled (FCR[0] set to zero), the data in the RBR must be read before the next data arrives, otherwise it will be overwritten, resulting in an overrun error. If FIFOs are enabled (FCR[0] set to one), this register accesses the head of the receive FIFO. If the receive FIFO is full and this register is not read before the next data character arrives, then the data already in the FIFO will be preserved but any incoming data will be lost. An overrun error will also occur. Shadow Transmit Holding Register 0: This is a shadow register for the THR and has been allocated sixteen 32-bit locations so as to accommodate burst accesses from the master. This register contains data to be transmitted on the serial output port (sout) in UART mode or the serial infrared output (sir_out_n) in infrared mode. Data should only be written to the THR when the THR Empty (THRE) bit (LSR[5]) is set. If FIFO's are disabled (FCR[0] set to zero) and THRE is set, writing a single character to the THR clears the THRE. Any additional writes to the THR before the THRE is set again causes the THR data to be overwritten. If FIFO's are enabled (FCR[0] set to one) and THRE is set, x number of characters of data may be written to the THR before the FIFO is full. The number x (default=16) is determined by the value of FIFO Depth that you set during configuration. Any attempt to write	0x0

Bit	Mode	Symbol	Description	Reset
			data when the FIFO is full results in the write data being lost.	

Table 435: **UART_SRBR_STHR11_REG (0x5002005C)**

Bit	Mode	Symbol	Description	Reset
31:8	-	-	Reserved	0x0
7:0	R/W	SRBR_STHRx	Shadow Receive Buffer Register x: This is a shadow register for the RBR and has been allocated sixteen 32-bit locations so as to accommodate burst accesses from the master. This register contains the data byte received on the serial input port (sin) in UART mode or the serial infrared input (sir_in) in infrared mode. The data in this register is valid only if the Data Ready (DR) bit in the Line status Register (LSR) is set. If FIFOs are disabled (FCR[0] set to zero), the data in the RBR must be read before the next data arrives, otherwise it will be overwritten, resulting in an overrun error. If FIFOs are enabled (FCR[0] set to one), this register accesses the head of the receive FIFO. If the receive FIFO is full and this register is not read before the next data character arrives, then the data already in the FIFO will be preserved but any incoming data will be lost. An overrun error will also occur. Shadow Transmit Holding Register 0: This is a shadow register for the THR and has been allocated sixteen 32-bit locations so as to accommodate burst accesses from the master. This register contains data to be transmitted on the serial output port (sout) in UART mode or the serial infrared output (sir_out_n) in infrared mode. Data should only be written to the THR when the THR Empty (THRE) bit (LSR[5]) is set. If FIFO's are disabled (FCR[0] set to zero) and THRE is set, writing a single character to the THR clears the THRE. Any additional writes to the THR before the THRE is set again causes the THR data to be overwritten. If FIFO's are enabled (FCR[0] set to one) and THRE is set, x number of characters of data may be written to the THR before the FIFO is full. The number x (default=16) is determined by the value of FIFO Depth that you set during configuration. Any attempt to write data when the FIFO is full results in the write data being lost.	0x0

Table 436: **UART_SRBR_STHR12_REG (0x50020060)**

Bit	Mode	Symbol	Description	Reset
31:8	-	-	Reserved	0x0
7:0	R/W	SRBR_STHRx	Shadow Receive Buffer Register x: This is a shadow register for the RBR and has been allocated sixteen 32-bit locations so as to accommodate burst accesses from the master. This register contains the data byte received on the serial input port (sin) in UART mode or the serial infrared input (sir_in) in infrared mode. The data in this register is valid only if the Data Ready (DR) bit in the Line status Register (LSR) is set. If FIFOs are disabled (FCR[0] set to zero), the data in the RBR must be read before the next data arrives, otherwise it will be	0x0

Bit	Mode	Symbol	Description	Reset
			overwritten, resulting in an overrun error. If FIFOs are enabled (FCR[0] set to one), this register accesses the head of the receive FIFO. If the receive FIFO is full and this register is not read before the next data character arrives, then the data already in the FIFO will be preserved but any incoming data will be lost. An overrun error will also occur. Shadow Transmit Holding Register 0: This is a shadow register for the THR and has been allocated sixteen 32-bit locations so as to accommodate burst accesses from the master. This register contains data to be transmitted on the serial output port (sout) in UART mode or the serial infrared output (sir_out_n) in infrared mode. Data should only be written to the THR when the THR Empty (THRE) bit (LSR[5]) is set. If FIFO's are disabled (FCR[0] set to zero) and THRE is set, writing a single character to the THR clears the THRE. Any additional writes to the THR before the THRE is set again causes the THR data to be overwritten. If FIFO's are enabled (FCR[0] set to one) and THRE is set, x number of characters of data may be written to the THR before the FIFO is full. The number x (default=16) is determined by the value of FIFO Depth that you set during configuration. Any attempt to write data when the FIFO is full results in the write data being lost.	

Table 437: **UART_SRBR_STHR13_REG (0x50020064)**

Bit	Mode	Symbol	Description	Reset
31:8	-	-	Reserved	0x0
7:0	R/W	SRBR_STHRx	Shadow Receive Buffer Register x: This is a shadow register for the RBR and has been allocated sixteen 32-bit locations so as to accommodate burst accesses from the master. This register contains the data byte received on the serial input port (sin) in UART mode or the serial infrared input (sir_in) in infrared mode. The data in this register is valid only if the Data Ready (DR) bit in the Line status Register (LSR) is set. If FIFOs are disabled (FCR[0] set to zero), the data in the RBR must be read before the next data arrives, otherwise it will be overwritten, resulting in an overrun error. If FIFOs are enabled (FCR[0] set to one), this register accesses the head of the receive FIFO. If the receive FIFO is full and this register is not read before the next data character arrives, then the data already in the FIFO will be preserved but any incoming data will be lost. An overrun error will also occur. Shadow Transmit Holding Register 0: This is a shadow register for the THR and has been allocated sixteen 32-bit locations so as to accommodate burst accesses from the master. This register contains data to be transmitted on the serial output port (sout) in UART mode or the serial infrared output (sir_out_n) in infrared mode. Data should only be written to the THR when the THR Empty (THRE) bit (LSR[5]) is set. If FIFO's are disabled (FCR[0] set to zero) and THRE is set, writing a single character to the THR clears the THRE. Any additional writes to the THR before the THRE is set again causes the THR data to be overwritten. If FIFO's are enabled (FCR[0] set to one)	0x0

Bit	Mode	Symbol	Description	Reset
			and THRE is set, x number of characters of data may be written to the THR before the FIFO is full. The number x (default=16) is determined by the value of FIFO Depth that you set during configuration. Any attempt to write data when the FIFO is full results in the write data being lost.	

Table 438: **UART_SRBR_STHR14_REG (0x50020068)**

Bit	Mode	Symbol	Description	Reset
31:8	-	-	Reserved	0x0
7:0	R/W	SRBR_STHRx	Shadow Receive Buffer Register x: This is a shadow register for the RBR and has been allocated sixteen 32-bit locations so as to accommodate burst accesses from the master. This register contains the data byte received on the serial input port (sin) in UART mode or the serial infrared input (sir_in) in infrared mode. The data in this register is valid only if the Data Ready (DR) bit in the Line status Register (LSR) is set. If FIFOs are disabled (FCR[0] set to zero), the data in the RBR must be read before the next data arrives, otherwise it will be overwritten, resulting in an overrun error. If FIFOs are enabled (FCR[0] set to one), this register accesses the head of the receive FIFO. If the receive FIFO is full and this register is not read before the next data character arrives, then the data already in the FIFO will be preserved but any incoming data will be lost. An overrun error will also occur. Shadow Transmit Holding Register 0: This is a shadow register for the THR and has been allocated sixteen 32-bit locations so as to accommodate burst accesses from the master. This register contains data to be transmitted on the serial output port (sout) in UART mode or the serial infrared output (sir_out_n) in infrared mode. Data should only be written to the THR when the THR Empty (THRE) bit (LSR[5]) is set. If FIFO's are disabled (FCR[0] set to zero) and THRE is set, writing a single character to the THR clears the THRE. Any additional writes to the THR before the THRE is set again causes the THR data to be overwritten. If FIFO's are enabled (FCR[0] set to one) and THRE is set, x number of characters of data may be written to the THR before the FIFO is full. The number x (default=16) is determined by the value of FIFO Depth that you set during configuration. Any attempt to write data when the FIFO is full results in the write data being lost.	0x0

Table 439: **UART_SRBR_STHR15_REG (0x5002006C)**

Bit	Mode	Symbol	Description	Reset
31:8	-	-	Reserved	0x0
7:0	R/W	SRBR_STHRx	Shadow Receive Buffer Register x: This is a shadow register for the RBR and has been allocated sixteen 32-bit locations so as to accommodate burst accesses from the master. This register contains the data byte received on the serial input port (sin) in UART mode or the serial infrared input (sir_in) in infrared mode. The data in this	0x0

Bit	Mode	Symbol	Description	Reset
			<p>register is valid only if the Data Ready (DR) bit in the Line status Register (LSR) is set. If FIFOs are disabled (FCR[0] set to zero), the data in the RBR must be read before the next data arrives, otherwise it will be overwritten, resulting in an overrun error. If FIFOs are enabled (FCR[0] set to one), this register accesses the head of the receive FIFO. If the receive FIFO is full and this register is not read before the next data character arrives, then the data already in the FIFO will be preserved but any incoming data will be lost. An overrun error will also occur. Shadow Transmit Holding Register 0: This is a shadow register for the THR and has been allocated sixteen 32-bit locations so as to accommodate burst accesses from the master. This register contains data to be transmitted on the serial output port (sout) in UART mode or the serial infrared output (sir_out_n) in infrared mode. Data should only be written to the THR when the THR Empty (THRE) bit (LSR[5]) is set. If FIFO's are disabled (FCR[0] set to zero) and THRE is set, writing a single character to the THR clears the THRE. Any additional writes to the THR before the THRE is set again causes the THR data to be overwritten. If FIFO's are enabled (FCR[0] set to one) and THRE is set, x number of characters of data may be written to the THR before the FIFO is full. The number x (default=16) is determined by the value of FIFO Depth that you set during configuration. Any attempt to write data when the FIFO is full results in the write data being lost.</p>	

Table 440: **UART_USR_REG (0x5002007C)**

Bit	Mode	Symbol	Description	Reset
31:5	-	-	Reserved	0x0
4	R	UART_RFF	<p>Receive FIFO Full.</p> <p>This is used to indicate that the receive FIFO is completely full.</p> <p>0 = Receive FIFO not full 1 = Receive FIFO Full</p> <p>This bit is cleared when the RX FIFO is no longer full.</p>	0x0
3	R	UART_RFNE	<p>Receive FIFO Not Empty.</p> <p>This is used to indicate that the receive FIFO contains one or more entries.</p> <p>0 = Receive FIFO is empty 1 = Receive FIFO is not empty</p> <p>This bit is cleared when the RX FIFO is empty.</p>	0x0
2	R	UART_TFE	<p>Transmit FIFO Empty.</p> <p>This is used to indicate that the transmit FIFO is completely empty.</p> <p>0 = Transmit FIFO is not empty 1 = Transmit FIFO is empty</p> <p>This bit is cleared when the TX FIFO is no longer empty.</p>	0x1
1	R	UART_TFNF	<p>Transmit FIFO Not Full.</p> <p>This is used to indicate that the transmit FIFO is not full.</p>	0x1

Bit	Mode	Symbol	Description	Reset
			0 = Transmit FIFO is full 1 = Transmit FIFO is not full This bit is cleared when the TX FIFO is full.	
0	R	UART_BUSY	UART Busy. This indicates that a serial transfer is in progress, when cleared indicates that the uart is idle or inactive. 0 = uart is idle or inactive 1 =uart is busy (actively transferring data) Note that it is possible for the UART Busy bit to be cleared even though a new character may have been sent from another device. That is, if the uart has no data in the THR and RBR and there is no transmission in progress and a start bit of a new character has just reached the uart. This is due to the fact that a valid start is not seen until the middle of the bit period and this duration is dependent on the baud divisor that has been programmed. If a second system clock has been implemented (CLOCK_MODE == Enabled) the assertion of this bit will also be delayed by several cycles of the slower clock.	0x0

Table 441: **UART_TFL_REG (0x50020080)**

Bit	Mode	Symbol	Description	Reset
4:0	R	UART_TRANSMIT_FIFO_LEVEL	Transmit FIFO Level. This indicates the number of data entries in the transmit FIFO.	0x0

Table 442: **UART_RFL_REG (0x50020084)**

Bit	Mode	Symbol	Description	Reset
4:0	R	UART_RECEIVE_FIFO_LEVEL	Receive FIFO Level. This indicates the number of data entries in the receive FIFO.	0x0

Table 443: **UART_SRR_REG (0x50020088)**

Bit	Mode	Symbol	Description	Reset
31:3	-	-	Reserved	0x0
2	W	UART_XFR	XMIT FIFO Reset. This is a shadow register for the XMIT FIFO Reset bit (FCR[2]). This can be used to remove the burden on software having to store previously written FCR values (which are pretty static) just to reset the transmit FIFO. This resets the control portion of the transmit FIFO and treats the FIFO as empty. Note that this bit is 'self-clearing'. It is not necessary to clear this bit.	0x0
1	W	UART_RFR	RCVR FIFO Reset. This is a shadow register for the RCVR FIFO Reset bit (FCR[1]). This can be used to remove the burden on software having to store previously written FCR values (which are pretty static) just to reset the receive FIFO	0x0

Bit	Mode	Symbol	Description	Reset
			This resets the control portion of the receive FIFO and treats the FIFO as empty. Note that this bit is 'self-clearing'. It is not necessary to clear this bit.	
0	W	UART_UR	UART Reset. This asynchronously resets the UART Ctrl and synchronously removes the reset assertion. For a two clock implementation both pclk and sclk domains are reset.	0x0

Table 444: **UART_SBCR_REG** (0x50020090)

Bit	Mode	Symbol	Description	Reset
31:1	-	-	Reserved	0x0
0	R/W	UART_SHADOW_BR EAK_CONTROL	Shadow Break Control Bit. This is a shadow register for the Break bit (LCR[6]), this can be used to remove the burden of having to performing a read modify write on the LCR. This is used to cause a break condition to be transmitted to the receiving device. If set to one the serial output is forced to the spacing (logic 0) state. When not in Loopback Mode, as determined by MCR[4], the sout line is forced low until the Break bit is cleared.	0x0

Table 445: **UART_SDMAM_REG** (0x50020094)

Bit	Mode	Symbol	Description	Reset
31:1	-	-	Reserved	0x0
0	R/W	UART_SHADOW_DM A_MODE	Shadow DMA Mode. This is a shadow register for the DMA mode bit (FCR[3]). This can be used to remove the burden of having to store the previously written value to the FCR in memory and having to mask this value so that only the DMA Mode bit gets updated. This determines the DMA signalling mode used for the dma_tx_req_n and dma_rx_req_n output signals. 0 = mode 0 1 = mode 1	0x0

Table 446: **UART_SFE_REG** (0x50020098)

Bit	Mode	Symbol	Description	Reset
31:1	-	-	Reserved	0x0
0	R/W	UART_SHADOW_FIF O_ENABLE	Shadow FIFO Enable. This is a shadow register for the FIFO enable bit (FCR[0]). This can be used to remove the burden of having to store the previously written value to the FCR in memory and having to mask this value so that only the FIFO enable bit gets updated. This enables/disables the transmit (XMIT) and receive (RCVR) FIFOs. If this bit is set to zero (disabled) after being enabled then both the XMIT and RCVR controller portion of FIFOs are reset.	0x0

Table 447: **UART_SRT_REG (0x5002009C)**

Bit	Mode	Symbol	Description	Reset
31:2	-	-	Reserved	0x0
1:0	R/W	UART_SHADOW_RCVR_TRIGGER	<p>Shadow RCVR Trigger.</p> <p>This is a shadow register for the RCVR trigger bits (FCR[7:6]). This can be used to remove the burden of having to store the previously written value to the FCR in memory and having to mask this value so that only the RCVR trigger bit gets updated.</p> <p>This is used to select the trigger level in the receiver FIFO at which the Received Data Available Interrupt is generated. It also determines when the dma_rx_req_n signal is asserted when DMA Mode (FCR[3]) = 1. The following trigger levels are supported:</p> <p>00 = 1 character in the FIFO 01 = FIFO ¼ full 10 = FIFO ½ full 11 = FIFO 2 less than full</p>	0x0

Table 448: **UART_STET_REG (0x500200A0)**

Bit	Mode	Symbol	Description	Reset
31:2	-	-	Reserved	0x0
1:0	R/W	UART_SHADOW_TX_EMPTY_TRIGGER	<p>Shadow TX Empty Trigger.</p> <p>This is a shadow register for the TX empty trigger bits (FCR[5:4]). This can be used to remove the burden of having to store the previously written value to the FCR in memory and having to mask this value so that only the TX empty trigger bit gets updated.</p> <p>This is used to select the empty threshold level at which the THRE Interrupts are generated when the mode is active. The following trigger levels are supported:</p> <p>00 = FIFO empty 01 = 2 characters in the FIFO 10 = FIFO ¼ full 11 = FIFO ½ full</p>	0x0

Table 449: **UART_HTX_REG (0x500200A4)**

Bit	Mode	Symbol	Description	Reset
31:1	-	-	Reserved	0x0
0	R/W	UART_HALT_TX	<p>This register is use to halt transmissions, so that the transmit FIFO can be filled by the master when FIFOs are implemented and enabled.</p> <p>0 = Halt TX disabled 1 = Halt TX enabled</p> <p>Note, if FIFOs are not enabled, the setting of the halt TX register has no effect on operation.</p>	0x0

Table 450: **UART_DMA_SA_REG (0x500200A8)**

Bit	Mode	Symbol	Description	Reset
31:1	-	-	Reserved	0x0
0	W	UART_DMA_SA	This register is use to perform DMA software acknowledge if a transfer needs to be terminated due to an error condition. For example, if the DMA disables the channel, then the DW_apb_uart should clear its request. This will cause the TX request, TX single, RX request and RX single signals to de-assert. Note that this bit is 'self-clearing' and it is not necessary to clear this bit.	0x0

Table 451: **UART_DLF_REG (0x500200C0)**

Bit	Mode	Symbol	Description	Reset
3:0	R/W	UART_DLF	The fractional value is added to integer value set by DLH, DLL. Fractional value is equal UART_DLF/16	0x0

Table 452: **UART_UCV_REG (0x500200F8)**

Bit	Mode	Symbol	Description	Reset
31:0	R	UART_UCV	Component Version	0x343031 2A

Table 453: **UART_CTR_REG (0x500200FC)**

Bit	Mode	Symbol	Description	Reset
31:0	R	UART_CTR	Component Type Register	0x445701 10

Table 454: **UART2_RBR_THR_DLL_REG (0x50020100)**

Bit	Mode	Symbol	Description	Reset
8	R/W	RBR_THR_9BIT	When 9BIT_DATA_EN, On read :Receive Buffer bit 8 - On write Transmit Buffer bit 8 when LCR_EXT[3]=1	0x0
7:0	R/W	RBR_THR_DLL	Receive Buffer Register: (RBR). This register contains the data byte received on the serial input port (sin) in UART mode or the serial infrared input (sir_in) in infrared mode. The data in this register is valid only if the Data Ready (DR) bit in the Line status Register (LSR) is set. If FIFOs are disabled (FCR[0] set to zero), the data in the RBR must be read before the next data arrives, otherwise it will be overwritten, resulting in an overrun error. If FIFOs are enabled (FCR[0] set to one), this register accesses the head of the receive FIFO. If the receive FIFO is full and this register is not read before the next data character arrives, then the data already in the FIFO will be preserved but any incoming data will be lost. An overrun error will also occur. Transmit Holding Register: (THR) This register contains data to be transmitted on the serial output port (sout) in UART mode or the serial infrared output (sir_out_n) in infrared mode. Data should	0x0

Bit	Mode	Symbol	Description	Reset
			<p>only be written to the THR when the THR Empty (THRE) bit (LSR[5]) is set. If FIFO's are disabled (FCR[0] set to zero) and THRE is set, writing a single character to the THR clears the THRE. Any additional writes to the THR before the THRE is set again causes the THR data to be overwritten. If FIFO's are enabled (FCR[0] set to one) and THRE is set, x number of characters of data may be written to the THR before the FIFO is full. The number x (default=16) is determined by the value of FIFO Depth that you set during configuration. Any attempt to write data when the FIFO is full results in the write data being lost.</p> <p>Divisor Latch (Low): (DLL)</p> <p>This register makes up the lower 8-bits of a 16-bit, read/write, Divisor Latch register that contains the baud rate divisor for the UART. This register may only be accessed when the DLAB bit (LCR[7]) is set. The output baud rate is equal to the serial clock (sclk) frequency divided by sixteen times the value of the baud rate divisor, as follows:</p> $\text{baud rate} = (\text{serial clock freq}) / (16 * \text{divisor})$ <p>Note that with the Divisor Latch Registers (DLL and DLH) set to zero, the baud clock is disabled and no serial communications will occur. Also, once the DLL is set, at least 8 clock cycles of the slowest DW_apb_uart clock should be allowed to pass before transmitting or receiving data.</p> <p>Divisor Latch (High): (DLH) (Note: This register is placed in UART_IER_DLH_REG with offset 0x4)</p> <p>Upper 8-bits of a 16-bit, read/write, Divisor Latch register that contains the baud rate divisor for the UART. This register may be accessed only when the DLAB bit (LCR[7]) is set. The output baud rate is equal to the serial clock frequency divided by sixteen times the value of the baud rate divisor, as follows:</p> $\text{baud rate} = (\text{serial clock freq}) / (16 * \text{divisor}).$ <p>Note that with the Divisor Latch Registers (DLL and DLH) set to zero, the baud clock is disabled and no serial communications occur. Also, once the DLH is set, at least 8 clock cycles of the slowest DW_apb_uart clock should be allowed to pass before transmitting or receiving data.</p>	

Table 455: **UART2_IER_DLH_REG (0x50020104)**

Bit	Mode	Symbol	Description	Reset
31:8	-	-	Reserved	0x0
7	R/W	PTIME_DLH7	<p>Interrupt Enable Register: PTIME, Programmable THRE Interrupt Mode Enable. This is used to enable/disable the generation of THRE Interrupt. 0 = disabled 1 = enabled</p> <p>Divisor Latch (High): Bit[7] of the 8 bit DLH register.</p>	0x0
6:5	R/W	DLH6_5	Divisor Latch (High): Bit[6:5] of the 8 bit DLH register	0x0
4	R/W	ELCOLR_DLH4	Interrupt Enable Register: ELCOLR (read only), this bit controls the method for clearing the status in the LSR	0x0

Bit	Mode	Symbol	Description	Reset
			register. This is applicable only for Overrun Error, Parity Error, Framing Error, and Break Interrupt status bits. 0 = LSR status bits are cleared either on reading Rx FIFO (RBR Read) or On reading LSR register. Divisor Latch (High): Bit[4] of the 8 bit DLH register	
3	R/W	EDSSI_DLH3	Interrupt Enable Register: EDSSI, Enable Modem Status Interrupt. This is used to enable/disable the generation of Modem Status Interrupt. This is the fourth highest priority interrupt. 0 = disabled 1 = enabled Divisor Latch (High): Bit[3] of the 8 bit DLH register	0x0
2	R/W	ELSI_DLH2	Interrupt Enable Register: ELSI, Enable Receiver Line Status Interrupt. This is used to enable/disable the generation of Receiver Line Status Interrupt. This is the highest priority interrupt. 0 = disabled 1 = enabled Divisor Latch (High): Bit[2] of the 8 bit DLH register.	0x0
1	R/W	ETBEI_DLH1	Interrupt Enable Register: ETBEI, Enable Transmit Holding Register Empty Interrupt. This is used to enable/disable the generation of Transmitter Holding Register Empty Interrupt. This is the third highest priority interrupt. 0 = disabled 1 = enabled Divisor Latch (High): Bit[1] of the 8 bit DLH register.	0x0
0	R/W	ERBFI_DLH0	Interrupt Enable Register: ERBFI, Enable Received Data Available Interrupt. This is used to enable/disable the generation of Received Data Available Interrupt and the Character Timeout Interrupt (if in FIFO mode and FIFO's enabled). These are the second highest priority interrupts. 0 = disabled 1 = enabled Divisor Latch (High): Bit[0] of the 8 bit DLH register.	0x0

Table 456: **UART2_IIR_FCR_REG (0x50020108)**

Bit	Mode	Symbol	Description	Reset
31:8	-	-	Reserved	0x0
7:0	R/W	IIR_FCR	On Read Interrupt Identification Register : Bits[7:6], FIFO's Enabled (or FIFOSE): This is used to indicate whether the FIFO's are enabled or disabled. 00 = disabled. 11 = enabled. Bits[5:4],Reserved Bits[3:0], Interrupt ID (or IID): This indicates the highest priority pending interrupt which can be one of the following types:0001 = no interrupt pending. 0010 = THR empty. 0100 = received data available. 0110 = receiver line status. 0111 = busy detect. 1100 = character timeout. On Write FIFO Control Register Bits[7:6], RCVR Trigger (or RT):. This is used to select the trigger level in the receiver FIFO at which the Received Data Available Interrupt will be generated. In auto flow control mode it is used to determine when the rts_n signal will be de-asserted. It also determines when the dma_rx_req_n signal will be asserted when in certain modes of operation. The following trigger levels are supported: 00 = 1 character in the FIFO 01 = FIFO 1/4 full 10 = FIFO 1/2 full 11 = FIFO 2 less than full	0x1

Bit	Mode	Symbol	Description	Reset
			<p>Bits[5:4], TX Empty Trigger (or TET): This is used to select the empty threshold level at which the THRE Interrupts will be generated when the mode is active. It also determines when the dma_tx_req_n signal will be asserted when in certain modes of operation. The following trigger levels are supported: 00 = FIFO empty 01 = 2 characters in the FIFO 10 = FIFO 1/4 full 11 = FIFO 1/2 full</p> <p>Bit[3], DMA Mode (or DMAM): This determines the DMA signalling mode used for the dma_tx_req_n and dma_rx_req_n output signals. 0 = mode 0 1 = mode 1</p> <p>Bit[2], XMIT FIFO Reset (or XFIFOR): This resets the control portion of the transmit FIFO and treats the FIFO as empty. Note that this bit is 'self-clearing' and it is not necessary to clear this bit.</p> <p>Bit[1], RCVR FIFO Reset (or RFIFOR): This resets the control portion of the receive FIFO and treats the FIFO as empty. Note that this bit is 'self-clearing' and it is not necessary to clear this bit.</p> <p>Bit[0], FIFO Enable (or FIFOE): This enables/disables the transmit (XMIT) and receive (RCVR) FIFO's. Whenever the value of this bit is changed both the XMIT and RCVR controller portion of FIFO's will be reset.</p>	

Table 457: UART2_LCR_REG (0x5002010C)

Bit	Mode	Symbol	Description	Reset
31:8	-	-	Reserved	0x0
7	R/W	UART_DLAB	<p>Divisor Latch Access Bit.</p> <p>This bit is used to enable reading and writing of the Divisor Latch register (DLL and DLH) to set the baud rate of the UART.</p> <p>This bit must be cleared after initial baud rate setup in order to access other registers.</p>	0x0
6	R/W	UART_BC	<p>Break Control Bit.</p> <p>This is used to cause a break condition to be transmitted to the receiving device. If set to one the serial output is forced to the spacing (logic 0) state. When not in Loopback Mode, as determined by MCR[4], the sout line is forced low until the Break bit is cleared.</p>	0x0
5	R/W	UART_SP	<p>Stick Parity. (writeable only when UART is not busy USR[0] is 0); otherwise always writable and always readable. This bit is used to force parity value. When PEN, EPS and Stick Parity are set to 1, the parity bit is transmitted and checked as logic 0. If PEN and Stick Parity are set to 1 and EPS is a logic 0, then parity bit is transmitted and checked as a logic 1. If this bit is set to 0, Stick Parity is disabled.</p>	0x0
4	R/W	UART_EPS	<p>Even Parity Select. Writeable only when UART is not busy (USR[0] is zero).</p> <p>This is used to select between even and odd parity, when parity is enabled (PEN set to one). If set to one, an even number of logic 1s is transmitted or checked. If set to zero, an odd number of logic 1s is transmitted or checked.</p>	0x0

Bit	Mode	Symbol	Description	Reset
3	R/W	UART_PEN	Parity Enable. Writeable only when UART is not busy (USR[0] is zero) This bit is used to enable and disable parity generation and detection in transmitted and received serial character respectively. 0 = parity disabled 1 = parity enabled	0x0
2	R/W	UART_STOP	Number of stop bits. This is used to select the number of stop bits per character that the peripheral transmits and receives. If set to zero, one stop bit is transmitted in the serial data. If set to one and the data bits are set to 5 (LCR[1:0] set to zero) one and a half stop bits is transmitted. Otherwise, two stop bits are transmitted. Note that regardless of the number of stop bits selected, the receiver checks only the first stop bit. 0 = 1 stop bit 1 = 1.5 stop bits when DLS (LCR[1:0]) is zero, else 2 stop bit	0x0
1:0	R/W	UART_DLS	Data Length Select. This is used to select the number of data bits per character that the peripheral transmits and receives. The number of bit that may be selected areas follows: 00 = 5 bits 01 = 6 bits 10 = 7 bits 11 = 8 bits	0x0

Table 458: **UART2_MCR_REG** (0x50020110)

Bit	Mode	Symbol	Description	Reset
31:7	-	-	Reserved	0x0
6	R/W	-	Reserved	0x0
5	R/W	UART_AFCE	Auto Flow Control Enable. When FIFOs are enabled and the Auto Flow Control Enable (AFCE) bit is set, Auto Flow Control features are enabled as described in "Auto Flow Control". 0 = Auto Flow Control Mode disabled 1 = Auto Flow Control Mode enabled	0x0
4	R/W	UART_LB	LoopBack Bit. This is used to put the UART into a diagnostic mode for test purposes. Data on the sout line is held high, while serial data output is looped back to the sin line, internally. In this mode all the interrupts are fully functional. Also, in loopback mode, the modem control inputs (dsr_n, cts_n, ri_n, dcd_n) are disconnected and the modem control outputs (dtr_n, rts_n) are looped back to the inputs, internally.	0x0
3	R/W	-	Reserved	0x0
2	R/W	-	Reserved	0x0

Bit	Mode	Symbol	Description	Reset
1	R/W	UART_RTS	<p>Request to Send.</p> <p>This is used to directly control the Request to Send (rts_n) output. The Request To Send (rts_n) output is used to inform the modem or data set that the UART is ready to exchange data.</p> <p>When Auto RTS Flow Control is not enabled (MCR[5] set to zero), the rts_n signal is set low by programming MCR[1] (RTS) to a high. In Auto Flow Control, active (MCR[5] set to one) and FIFOs enable (FCR[0] set to one), the rts_n output is controlled in the same way, but is also gated with the receiver FIFO threshold trigger (rts_n is inactive high when above the threshold). The rts_n signal is de-asserted when MCR[1] is set low.</p> <p>Note that in Loopback mode (MCR[4] set to one), the rts_n output is held inactive high while the value of this location is internally looped back to an input.</p>	0x0
0	R/W	-	Reserved	0x0

Table 459: UART2_LSR_REG (0x50020114)

Bit	Mode	Symbol	Description	Reset
8	R	UART_ADDR_RCVD	<p>Address Received Bit.</p> <p>If 9Bit data mode (LCR_EXT[0]=1) is enabled, this bit is used to indicate the 9th bit of the receive data is set to 1. This bit can also be used to indicate whether the incoming character is address or data.</p> <p>1 = Indicates the character is address. 0 = Indicates the character is data.</p> <p>In the FIFO mode, since the 9th bit is associated with a character received, it is revealed when the character with the 9th bit set to 1 is at the top of the FIFO.</p> <p>Reading the LSR clears the 9BIT.</p> <p>Note: User needs to ensure that interrupt gets cleared (reading LSR register) before the next address byte arrives. If there is a delay in clearing the interrupt, then Software will not be able to distinguish between multiple address related interrupt.</p>	0x0
7	R	UART_RFE	<p>Receiver FIFO Error bit.</p> <p>This bit is only relevant when FIFOs are enabled (FCR[0] set to one). This is used to indicate if there is at least one parity error, framing error, or break indication in the FIFO.</p> <p>0 = no error in RX FIFO 1 = error in RX FIFO</p> <p>This bit is cleared when the LSR is read and the character with the error is at the top of the receiver FIFO and there are no subsequent errors in the FIFO.</p>	0x0
6	R	UART_TEMT	<p>Transmitter Empty bit.</p> <p>If FIFOs enabled (FCR[0] set to one), this bit is set whenever the Transmitter Shift Register and the FIFO are both empty. If FIFOs are disabled, this bit is set whenever the Transmitter Holding Register and the Transmitter Shift Register are both empty.</p>	0x1

Bit	Mode	Symbol	Description	Reset
5	R	UART_THRE	<p>Transmit Holding Register Empty bit.</p> <p>If THRE mode is disabled (IER[7] set to zero) and regardless of FIFO's being implemented/enabled or not, this bit indicates that the THR or TX FIFO is empty.</p> <p>This bit is set whenever data is transferred from the THR or TX FIFO to the transmitter shift register and no new data has been written to the THR or TX FIFO. This also causes a THRE Interrupt to occur, if the THRE Interrupt is enabled. If both modes are active (IER[7] set to one and FCR[0] set to one respectively), the functionality is switched to indicate the transmitter FIFO is full, and no longer controls THRE interrupts, which are then controlled by the FCR[5:4] threshold setting.</p>	0x1
4	R	UART_BI	<p>Break Interrupt bit.</p> <p>This is used to indicate the detection of a break sequence on the serial input data.</p> <p>If in UART mode (SIR_MODE == Disabled), it is set whenever the serial input, sin, is held in a logic '0' state for longer than the sum of start time + data bits + parity + stop bits.</p> <p>In the FIFO mode, the character associated with the break condition is carried through the FIFO and is revealed when the character is at the top of the FIFO. Reading the LSR clears the BI bit. In the non-FIFO mode, the BI indication occurs immediately and persists until the LSR is read.</p>	0x0
3	R	UART_FE	<p>Framing Error bit.</p> <p>This is used to indicate the occurrence of a framing error in the receiver. A framing error occurs when the receiver does not detect a valid STOP bit in the received data.</p> <p>In the FIFO mode, since the framing error is associated with a character received, it is revealed when the character with the framing error is at the top of the FIFO. When a framing error occurs, the UART tries to resynchronize. It does this by assuming that the error was due to the start bit of the next character and then continues receiving the other bit i.e. data, and/or parity and stop. It should be noted that the Framing Error (FE) bit (LSR[3]) is set if a break interrupt has occurred, as indicated by Break Interrupt (BI) bit (LSR[4]).</p> <p>0 = no framing error 1 = framing error</p> <p>Reading the LSR clears the FE bit.</p>	0x0
2	R	UART_PE	<p>Parity Error bit.</p> <p>This is used to indicate the occurrence of a parity error in the receiver if the Parity Enable (PEN) bit (LCR[3]) is set.</p> <p>In the FIFO mode, since the parity error is associated with a character received, it is revealed when the character with the parity error arrives at the top of the FIFO.</p> <p>It should be noted that the Parity Error (PE) bit (LSR[2]) is set if a break interrupt has occurred, as indicated by Break Interrupt (BI) bit (LSR[4]).</p> <p>0 = no parity error</p>	0x0

Bit	Mode	Symbol	Description	Reset
			1 = parity error Reading the LSR clears the PE bit.	
1	R	UART_OE	Overrun error bit. This is used to indicate the occurrence of an overrun error. This occurs if a new data character was received before the previous data was read. In the non-FIFO mode, the OE bit is set when a new character arrives in the receiver before the previous character was read from the RBR. When this happens, the data in the RBR is overwritten. In the FIFO mode, an overrun error occurs when the FIFO is full and a new character arrives at the receiver. The data in the FIFO is retained and the data in the receive shift register is lost. 0 = no overrun error 1 = overrun error Reading the LSR clears the OE bit.	0x0
0	R	UART_DR	Data Ready bit. This is used to indicate that the receiver contains at least one character in the RBR or the receiver FIFO. 0 = no data ready 1 = data ready This bit is cleared when the RBR is read in non-FIFO mode, or when the receiver FIFO is empty, in FIFO mode.	0x0

Table 460: UART2_MSR_REG (0x50020118)

Bit	Mode	Symbol	Description	Reset
31:5	-	-	Reserved	0x0
4	R	UART_CTS	Clear to Send. This is used to indicate the current state of the modem control line cts_n. This bit is the complement of cts_n. When the Clear to Send input (cts_n) is asserted it is an indication that the modem or data set is ready to exchange data with the UART Ctrl. 0 = cts_n input is de-asserted (logic 1) 1 = cts_n input is asserted (logic 0) In Loopback Mode (MCR[4] = 1), CTS is the same as MCR[1] (RTS).	0x1
3:1	-	-	Reserved	0x0
0	R	UART_DCTS	Delta Clear to Send. This is used to indicate that the modem control line cts_n has changed since the last time the MSR was read. 0 = no change on cts_n since last read of MSR 1 = change on cts_n since last read of MSR Reading the MSR clears the DCTS bit. In Loopback Mode (MCR[4] = 1), DCTS reflects changes on MCR[1] (RTS).	0x0

Bit	Mode	Symbol	Description	Reset
			Note, if the DCTS bit is not set and the cts_n signal is asserted (low) and a reset occurs (software or otherwise), then the DCTS bit is set when the reset is removed if the cts_n signal remains asserted.	

Table 461: **UART2_SCR_REG (0x5002011C)**

Bit	Mode	Symbol	Description	Reset
31:8	-	-	Reserved	0x0
7:0	R/W	UART_SCRATCH_PA D	This register is for programmers to use as a temporary storage space. It has no defined purpose in the UART Ctrl.	0x0

Table 462: **UART2_SRBR_STHR0_REG (0x50020130)**

Bit	Mode	Symbol	Description	Reset
31:8	-	-	Reserved	0x0
7:0	R/W	SRBR_STHRx	Shadow Receive Buffer Register x: This is a shadow register for the RBR and has been allocated sixteen 32-bit locations so as to accommodate burst accesses from the master. This register contains the data byte received on the serial input port (sin) in UART mode or the serial infrared input (sir_in) in infrared mode. The data in this register is valid only if the Data Ready (DR) bit in the Line status Register (LSR) is set. If FIFOs are disabled (FCR[0] set to zero), the data in the RBR must be read before the next data arrives, otherwise it will be overwritten, resulting in an overrun error. If FIFOs are enabled (FCR[0] set to one), this register accesses the head of the receive FIFO. If the receive FIFO is full and this register is not read before the next data character arrives, then the data already in the FIFO will be preserved but any incoming data will be lost. An overrun error will also occur. Shadow Transmit Holding Register 0: This is a shadow register for the THR and has been allocated sixteen 32-bit locations so as to accommodate burst accesses from the master. This register contains data to be transmitted on the serial output port (sout) in UART mode or the serial infrared output (sir_out_n) in infrared mode. Data should only be written to the THR when the THR Empty (THRE) bit (LSR[5]) is set. If FIFO's are disabled (FCR[0] set to zero) and THRE is set, writing a single character to the THR clears the THRE. Any additional writes to the THR before the THRE is set again causes the THR data to be overwritten. If FIFO's are enabled (FCR[0] set to one) and THRE is set, x number of characters of data may be written to the THR before the FIFO is full. The number x (default=16) is determined by the value of FIFO Depth that you set during configuration. Any attempt to write data when the FIFO is full results in the write data being lost.	0x0

Table 463: **UART2_SRBR_STHR1_REG (0x50020134)**

Bit	Mode	Symbol	Description	Reset
31:8	-	-	Reserved	0x0
7:0	R/W	SRBR_STHRx	Shadow Receive Buffer Register x: This is a shadow register for the RBR and has been allocated sixteen 32-bit locations so as to accommodate burst accesses from the master. This register contains the data byte received on the serial input port (sin) in UART mode or the serial infrared input (sir_in) in infrared mode. The data in this register is valid only if the Data Ready (DR) bit in the Line status Register (LSR) is set. If FIFOs are disabled (FCR[0] set to zero), the data in the RBR must be read before the next data arrives, otherwise it will be overwritten, resulting in an overrun error. If FIFOs are enabled (FCR[0] set to one), this register accesses the head of the receive FIFO. If the receive FIFO is full and this register is not read before the next data character arrives, then the data already in the FIFO will be preserved but any incoming data will be lost. An overrun error will also occur. Shadow Transmit Holding Register 0: This is a shadow register for the THR and has been allocated sixteen 32-bit locations so as to accommodate burst accesses from the master. This register contains data to be transmitted on the serial output port (sout) in UART mode or the serial infrared output (sir_out_n) in infrared mode. Data should only be written to the THR when the THR Empty (THRE) bit (LSR[5]) is set. If FIFO's are disabled (FCR[0] set to zero) and THRE is set, writing a single character to the THR clears the THRE. Any additional writes to the THR before the THRE is set again causes the THR data to be overwritten. If FIFO's are enabled (FCR[0] set to one) and THRE is set, x number of characters of data may be written to the THR before the FIFO is full. The number x (default=16) is determined by the value of FIFO Depth that you set during configuration. Any attempt to write data when the FIFO is full results in the write data being lost.	0x0

Table 464: **UART2_SRBR_STHR2_REG (0x50020138)**

Bit	Mode	Symbol	Description	Reset
31:8	-	-	Reserved	0x0
7:0	R/W	SRBR_STHRx	Shadow Receive Buffer Register x: This is a shadow register for the RBR and has been allocated sixteen 32-bit locations so as to accommodate burst accesses from the master. This register contains the data byte received on the serial input port (sin) in UART mode or the serial infrared input (sir_in) in infrared mode. The data in this register is valid only if the Data Ready (DR) bit in the Line status Register (LSR) is set. If FIFOs are disabled (FCR[0] set to zero), the data in the RBR must be read before the next data arrives, otherwise it will be overwritten, resulting in an overrun error. If FIFOs are enabled (FCR[0] set to one), this register accesses the head of the receive FIFO. If the receive FIFO is full and this register is not read before the next data character arrives, then the data already in the FIFO will be preserved but any incoming data will be lost. An overrun	0x0

Bit	Mode	Symbol	Description	Reset
			error will also occur. Shadow Transmit Holding Register 0: This is a shadow register for the THR and has been allocated sixteen 32-bit locations so as to accommodate burst accesses from the master. This register contains data to be transmitted on the serial output port (sout) in UART mode or the serial infrared output (sir_out_n) in infrared mode. Data should only be written to the THR when the THR Empty (THRE) bit (LSR[5]) is set. If FIFO's are disabled (FCR[0] set to zero) and THRE is set, writing a single character to the THR clears the THRE. Any additional writes to the THR before the THRE is set again causes the THR data to be overwritten. If FIFO's are enabled (FCR[0] set to one) and THRE is set, x number of characters of data may be written to the THR before the FIFO is full. The number x (default=16) is determined by the value of FIFO Depth that you set during configuration. Any attempt to write data when the FIFO is full results in the write data being lost.	

Table 465: **UART2_SRBR_STHR3_REG (0x5002013C)**

Bit	Mode	Symbol	Description	Reset
31:8	-	-	Reserved	0x0
7:0	R/W	SRBR_STHRx	Shadow Receive Buffer Register x: This is a shadow register for the RBR and has been allocated sixteen 32-bit locations so as to accommodate burst accesses from the master. This register contains the data byte received on the serial input port (sin) in UART mode or the serial infrared input (sir_in) in infrared mode. The data in this register is valid only if the Data Ready (DR) bit in the Line status Register (LSR) is set. If FIFOs are disabled (FCR[0] set to zero), the data in the RBR must be read before the next data arrives, otherwise it will be overwritten, resulting in an overrun error. If FIFOs are enabled (FCR[0] set to one), this register accesses the head of the receive FIFO. If the receive FIFO is full and this register is not read before the next data character arrives, then the data already in the FIFO will be preserved but any incoming data will be lost. An overrun error will also occur. Shadow Transmit Holding Register 0: This is a shadow register for the THR and has been allocated sixteen 32-bit locations so as to accommodate burst accesses from the master. This register contains data to be transmitted on the serial output port (sout) in UART mode or the serial infrared output (sir_out_n) in infrared mode. Data should only be written to the THR when the THR Empty (THRE) bit (LSR[5]) is set. If FIFO's are disabled (FCR[0] set to zero) and THRE is set, writing a single character to the THR clears the THRE. Any additional writes to the THR before the THRE is set again causes the THR data to be overwritten. If FIFO's are enabled (FCR[0] set to one) and THRE is set, x number of characters of data may be written to the THR before the FIFO is full. The number x (default=16) is determined by the value of FIFO Depth that you set during configuration. Any attempt to write data when the FIFO is full results in the write data being lost.	0x0

Table 466: **UART2_SRBR_STHR4_REG (0x50020140)**

Bit	Mode	Symbol	Description	Reset
31:8	-	-	Reserved	0x0
7:0	R/W	SRBR_STHRx	Shadow Receive Buffer Register x: This is a shadow register for the RBR and has been allocated sixteen 32-bit locations so as to accommodate burst accesses from the master. This register contains the data byte received on the serial input port (sin) in UART mode or the serial infrared input (sir_in) in infrared mode. The data in this register is valid only if the Data Ready (DR) bit in the Line status Register (LSR) is set. If FIFOs are disabled (FCR[0] set to zero), the data in the RBR must be read before the next data arrives, otherwise it will be overwritten, resulting in an overrun error. If FIFOs are enabled (FCR[0] set to one), this register accesses the head of the receive FIFO. If the receive FIFO is full and this register is not read before the next data character arrives, then the data already in the FIFO will be preserved but any incoming data will be lost. An overrun error will also occur. Shadow Transmit Holding Register 0: This is a shadow register for the THR and has been allocated sixteen 32-bit locations so as to accommodate burst accesses from the master. This register contains data to be transmitted on the serial output port (sout) in UART mode or the serial infrared output (sir_out_n) in infrared mode. Data should only be written to the THR when the THR Empty (THRE) bit (LSR[5]) is set. If FIFO's are disabled (FCR[0] set to zero) and THRE is set, writing a single character to the THR clears the THRE. Any additional writes to the THR before the THRE is set again causes the THR data to be overwritten. If FIFO's are enabled (FCR[0] set to one) and THRE is set, x number of characters of data may be written to the THR before the FIFO is full. The number x (default=16) is determined by the value of FIFO Depth that you set during configuration. Any attempt to write data when the FIFO is full results in the write data being lost.	0x0

Table 467: **UART2_SRBR_STHR5_REG (0x50020144)**

Bit	Mode	Symbol	Description	Reset
31:8	-	-	Reserved	0x0
7:0	R/W	SRBR_STHRx	Shadow Receive Buffer Register x: This is a shadow register for the RBR and has been allocated sixteen 32-bit locations so as to accommodate burst accesses from the master. This register contains the data byte received on the serial input port (sin) in UART mode or the serial infrared input (sir_in) in infrared mode. The data in this register is valid only if the Data Ready (DR) bit in the Line status Register (LSR) is set. If FIFOs are disabled (FCR[0] set to zero), the data in the RBR must be read before the next data arrives, otherwise it will be overwritten, resulting in an overrun error. If FIFOs are enabled (FCR[0] set to one), this register accesses the head of the receive FIFO. If the receive FIFO is full and this register is not read before the next data character	0x0

Bit	Mode	Symbol	Description	Reset
			arrives, then the data already in the FIFO will be preserved but any incoming data will be lost. An overrun error will also occur. Shadow Transmit Holding Register 0: This is a shadow register for the THR and has been allocated sixteen 32-bit locations so as to accommodate burst accesses from the master. This register contains data to be transmitted on the serial output port (sout) in UART mode or the serial infrared output (sir_out_n) in infrared mode. Data should only be written to the THR when the THR Empty (THRE) bit (LSR[5]) is set. If FIFO's are disabled (FCR[0] set to zero) and THRE is set, writing a single character to the THR clears the THRE. Any additional writes to the THR before the THRE is set again causes the THR data to be overwritten. If FIFO's are enabled (FCR[0] set to one) and THRE is set, x number of characters of data may be written to the THR before the FIFO is full. The number x (default=16) is determined by the value of FIFO Depth that you set during configuration. Any attempt to write data when the FIFO is full results in the write data being lost.	

Table 468: **UART2_SRBR_STHR6_REG (0x50020148)**

Bit	Mode	Symbol	Description	Reset
31:8	-	-	Reserved	0x0
7:0	R/W	SRBR_STHRx	Shadow Receive Buffer Register x: This is a shadow register for the RBR and has been allocated sixteen 32-bit locations so as to accommodate burst accesses from the master. This register contains the data byte received on the serial input port (sin) in UART mode or the serial infrared input (sir_in) in infrared mode. The data in this register is valid only if the Data Ready (DR) bit in the Line status Register (LSR) is set. If FIFOs are disabled (FCR[0] set to zero), the data in the RBR must be read before the next data arrives, otherwise it will be overwritten, resulting in an overrun error. If FIFOs are enabled (FCR[0] set to one), this register accesses the head of the receive FIFO. If the receive FIFO is full and this register is not read before the next data character arrives, then the data already in the FIFO will be preserved but any incoming data will be lost. An overrun error will also occur. Shadow Transmit Holding Register 0: This is a shadow register for the THR and has been allocated sixteen 32-bit locations so as to accommodate burst accesses from the master. This register contains data to be transmitted on the serial output port (sout) in UART mode or the serial infrared output (sir_out_n) in infrared mode. Data should only be written to the THR when the THR Empty (THRE) bit (LSR[5]) is set. If FIFO's are disabled (FCR[0] set to zero) and THRE is set, writing a single character to the THR clears the THRE. Any additional writes to the THR before the THRE is set again causes the THR data to be overwritten. If FIFO's are enabled (FCR[0] set to one) and THRE is set, x number of characters of data may be written to the THR before the FIFO is full. The number x (default=16) is determined by the value of FIFO Depth that you set during configuration. Any attempt to write	0x0

Bit	Mode	Symbol	Description	Reset
			data when the FIFO is full results in the write data being lost.	

Table 469: **UART2_SRBR_STHR7_REG (0x5002014C)**

Bit	Mode	Symbol	Description	Reset
31:8	-	-	Reserved	0x0
7:0	R/W	SRBR_STHRx	Shadow Receive Buffer Register x: This is a shadow register for the RBR and has been allocated sixteen 32-bit locations so as to accommodate burst accesses from the master. This register contains the data byte received on the serial input port (sin) in UART mode or the serial infrared input (sir_in) in infrared mode. The data in this register is valid only if the Data Ready (DR) bit in the Line status Register (LSR) is set. If FIFOs are disabled (FCR[0] set to zero), the data in the RBR must be read before the next data arrives, otherwise it will be overwritten, resulting in an overrun error. If FIFOs are enabled (FCR[0] set to one), this register accesses the head of the receive FIFO. If the receive FIFO is full and this register is not read before the next data character arrives, then the data already in the FIFO will be preserved but any incoming data will be lost. An overrun error will also occur. Shadow Transmit Holding Register 0: This is a shadow register for the THR and has been allocated sixteen 32-bit locations so as to accommodate burst accesses from the master. This register contains data to be transmitted on the serial output port (sout) in UART mode or the serial infrared output (sir_out_n) in infrared mode. Data should only be written to the THR when the THR Empty (THRE) bit (LSR[5]) is set. If FIFO's are disabled (FCR[0] set to zero) and THRE is set, writing a single character to the THR clears the THRE. Any additional writes to the THR before the THRE is set again causes the THR data to be overwritten. If FIFO's are enabled (FCR[0] set to one) and THRE is set, x number of characters of data may be written to the THR before the FIFO is full. The number x (default=16) is determined by the value of FIFO Depth that you set during configuration. Any attempt to write data when the FIFO is full results in the write data being lost.	0x0

Table 470: **UART2_SRBR_STHR8_REG (0x50020150)**

Bit	Mode	Symbol	Description	Reset
31:8	-	-	Reserved	0x0
7:0	R/W	SRBR_STHRx	Shadow Receive Buffer Register x: This is a shadow register for the RBR and has been allocated sixteen 32-bit locations so as to accommodate burst accesses from the master. This register contains the data byte received on the serial input port (sin) in UART mode or the serial infrared input (sir_in) in infrared mode. The data in this register is valid only if the Data Ready (DR) bit in the Line status Register (LSR) is set. If FIFOs are disabled (FCR[0] set to zero), the data in the RBR must be read before the next data arrives, otherwise it will be	0x0

Bit	Mode	Symbol	Description	Reset
			overwritten, resulting in an overrun error. If FIFOs are enabled (FCR[0] set to one), this register accesses the head of the receive FIFO. If the receive FIFO is full and this register is not read before the next data character arrives, then the data already in the FIFO will be preserved but any incoming data will be lost. An overrun error will also occur. Shadow Transmit Holding Register 0: This is a shadow register for the THR and has been allocated sixteen 32-bit locations so as to accommodate burst accesses from the master. This register contains data to be transmitted on the serial output port (sout) in UART mode or the serial infrared output (sir_out_n) in infrared mode. Data should only be written to the THR when the THR Empty (THRE) bit (LSR[5]) is set. If FIFO's are disabled (FCR[0] set to zero) and THRE is set, writing a single character to the THR clears the THRE. Any additional writes to the THR before the THRE is set again causes the THR data to be overwritten. If FIFO's are enabled (FCR[0] set to one) and THRE is set, x number of characters of data may be written to the THR before the FIFO is full. The number x (default=16) is determined by the value of FIFO Depth that you set during configuration. Any attempt to write data when the FIFO is full results in the write data being lost.	

Table 471: **UART2_SRBR_STHR9_REG (0x50020154)**

Bit	Mode	Symbol	Description	Reset
31:8	-	-	Reserved	0x0
7:0	R/W	SRBR_STHRx	Shadow Receive Buffer Register x: This is a shadow register for the RBR and has been allocated sixteen 32-bit locations so as to accommodate burst accesses from the master. This register contains the data byte received on the serial input port (sin) in UART mode or the serial infrared input (sir_in) in infrared mode. The data in this register is valid only if the Data Ready (DR) bit in the Line status Register (LSR) is set. If FIFOs are disabled (FCR[0] set to zero), the data in the RBR must be read before the next data arrives, otherwise it will be overwritten, resulting in an overrun error. If FIFOs are enabled (FCR[0] set to one), this register accesses the head of the receive FIFO. If the receive FIFO is full and this register is not read before the next data character arrives, then the data already in the FIFO will be preserved but any incoming data will be lost. An overrun error will also occur. Shadow Transmit Holding Register 0: This is a shadow register for the THR and has been allocated sixteen 32-bit locations so as to accommodate burst accesses from the master. This register contains data to be transmitted on the serial output port (sout) in UART mode or the serial infrared output (sir_out_n) in infrared mode. Data should only be written to the THR when the THR Empty (THRE) bit (LSR[5]) is set. If FIFO's are disabled (FCR[0] set to zero) and THRE is set, writing a single character to the THR clears the THRE. Any additional writes to the THR before the THRE is set again causes the THR data to be overwritten. If FIFO's are enabled (FCR[0] set to one)	0x0

Bit	Mode	Symbol	Description	Reset
			and THRE is set, x number of characters of data may be written to the THR before the FIFO is full. The number x (default=16) is determined by the value of FIFO Depth that you set during configuration. Any attempt to write data when the FIFO is full results in the write data being lost.	

Table 472: **UART2_SRBR_STHR10_REG (0x50020158)**

Bit	Mode	Symbol	Description	Reset
31:8	-	-	Reserved	0x0
7:0	R/W	SRBR_STHRx	Shadow Receive Buffer Register x: This is a shadow register for the RBR and has been allocated sixteen 32-bit locations so as to accommodate burst accesses from the master. This register contains the data byte received on the serial input port (sin) in UART mode or the serial infrared input (sir_in) in infrared mode. The data in this register is valid only if the Data Ready (DR) bit in the Line status Register (LSR) is set. If FIFOs are disabled (FCR[0] set to zero), the data in the RBR must be read before the next data arrives, otherwise it will be overwritten, resulting in an overrun error. If FIFOs are enabled (FCR[0] set to one), this register accesses the head of the receive FIFO. If the receive FIFO is full and this register is not read before the next data character arrives, then the data already in the FIFO will be preserved but any incoming data will be lost. An overrun error will also occur. Shadow Transmit Holding Register 0: This is a shadow register for the THR and has been allocated sixteen 32-bit locations so as to accommodate burst accesses from the master. This register contains data to be transmitted on the serial output port (sout) in UART mode or the serial infrared output (sir_out_n) in infrared mode. Data should only be written to the THR when the THR Empty (THRE) bit (LSR[5]) is set. If FIFO's are disabled (FCR[0] set to zero) and THRE is set, writing a single character to the THR clears the THRE. Any additional writes to the THR before the THRE is set again causes the THR data to be overwritten. If FIFO's are enabled (FCR[0] set to one) and THRE is set, x number of characters of data may be written to the THR before the FIFO is full. The number x (default=16) is determined by the value of FIFO Depth that you set during configuration. Any attempt to write data when the FIFO is full results in the write data being lost.	0x0

Table 473: **UART2_SRBR_STHR11_REG (0x5002015C)**

Bit	Mode	Symbol	Description	Reset
31:8	-	-	Reserved	0x0
7:0	R/W	SRBR_STHRx	Shadow Receive Buffer Register x: This is a shadow register for the RBR and has been allocated sixteen 32-bit locations so as to accommodate burst accesses from the master. This register contains the data byte received on the serial input port (sin) in UART mode or the serial infrared input (sir_in) in infrared mode. The data in this	0x0

Bit	Mode	Symbol	Description	Reset
			<p>register is valid only if the Data Ready (DR) bit in the Line status Register (LSR) is set. If FIFOs are disabled (FCR[0] set to zero), the data in the RBR must be read before the next data arrives, otherwise it will be overwritten, resulting in an overrun error. If FIFOs are enabled (FCR[0] set to one), this register accesses the head of the receive FIFO. If the receive FIFO is full and this register is not read before the next data character arrives, then the data already in the FIFO will be preserved but any incoming data will be lost. An overrun error will also occur. Shadow Transmit Holding Register 0: This is a shadow register for the THR and has been allocated sixteen 32-bit locations so as to accommodate burst accesses from the master. This register contains data to be transmitted on the serial output port (sout) in UART mode or the serial infrared output (sir_out_n) in infrared mode. Data should only be written to the THR when the THR Empty (THRE) bit (LSR[5]) is set. If FIFO's are disabled (FCR[0] set to zero) and THRE is set, writing a single character to the THR clears the THRE. Any additional writes to the THR before the THRE is set again causes the THR data to be overwritten. If FIFO's are enabled (FCR[0] set to one) and THRE is set, x number of characters of data may be written to the THR before the FIFO is full. The number x (default=16) is determined by the value of FIFO Depth that you set during configuration. Any attempt to write data when the FIFO is full results in the write data being lost.</p>	

Table 474: UART2_SRRB_STHR12_REG (0x50020160)

Bit	Mode	Symbol	Description	Reset
31:8	-	-	Reserved	0x0
7:0	R/W	SRBR_STHR _x	<p>Shadow Receive Buffer Register x: This is a shadow register for the RBR and has been allocated sixteen 32-bit locations so as to accommodate burst accesses from the master. This register contains the data byte received on the serial input port (sin) in UART mode or the serial infrared input (sir_in) in infrared mode. The data in this register is valid only if the Data Ready (DR) bit in the Line status Register (LSR) is set. If FIFOs are disabled (FCR[0] set to zero), the data in the RBR must be read before the next data arrives, otherwise it will be overwritten, resulting in an overrun error. If FIFOs are enabled (FCR[0] set to one), this register accesses the head of the receive FIFO. If the receive FIFO is full and this register is not read before the next data character arrives, then the data already in the FIFO will be preserved but any incoming data will be lost. An overrun error will also occur. Shadow Transmit Holding Register 0: This is a shadow register for the THR and has been allocated sixteen 32-bit locations so as to accommodate burst accesses from the master. This register contains data to be transmitted on the serial output port (sout) in UART mode or the serial infrared output (sir_out_n) in infrared mode. Data should only be written to the THR when the THR Empty (THRE) bit (LSR[5]) is set. If FIFO's are disabled (FCR[0] set to zero) and THRE is</p>	0x0

Bit	Mode	Symbol	Description	Reset
			set, writing a single character to the THR clears the THRE. Any additional writes to the THR before the THRE is set again causes the THR data to be overwritten. If FIFO's are enabled (FCR[0] set to one) and THRE is set, x number of characters of data may be written to the THR before the FIFO is full. The number x (default=16) is determined by the value of FIFO Depth that you set during configuration. Any attempt to write data when the FIFO is full results in the write data being lost.	

Table 475: **UART2_SRBR_STHR13_REG (0x50020164)**

Bit	Mode	Symbol	Description	Reset
31:8	-	-	Reserved	0x0
7:0	R/W	SRBR_STHRx	Shadow Receive Buffer Register x: This is a shadow register for the RBR and has been allocated sixteen 32-bit locations so as to accommodate burst accesses from the master. This register contains the data byte received on the serial input port (sin) in UART mode or the serial infrared input (sir_in) in infrared mode. The data in this register is valid only if the Data Ready (DR) bit in the Line status Register (LSR) is set. If FIFOs are disabled (FCR[0] set to zero), the data in the RBR must be read before the next data arrives, otherwise it will be overwritten, resulting in an overrun error. If FIFOs are enabled (FCR[0] set to one), this register accesses the head of the receive FIFO. If the receive FIFO is full and this register is not read before the next data character arrives, then the data already in the FIFO will be preserved but any incoming data will be lost. An overrun error will also occur. Shadow Transmit Holding Register 0: This is a shadow register for the THR and has been allocated sixteen 32-bit locations so as to accommodate burst accesses from the master. This register contains data to be transmitted on the serial output port (sout) in UART mode or the serial infrared output (sir_out_n) in infrared mode. Data should only be written to the THR when the THR Empty (THRE) bit (LSR[5]) is set. If FIFO's are disabled (FCR[0] set to zero) and THRE is set, writing a single character to the THR clears the THRE. Any additional writes to the THR before the THRE is set again causes the THR data to be overwritten. If FIFO's are enabled (FCR[0] set to one) and THRE is set, x number of characters of data may be written to the THR before the FIFO is full. The number x (default=16) is determined by the value of FIFO Depth that you set during configuration. Any attempt to write data when the FIFO is full results in the write data being lost.	0x0

Table 476: **UART2_SRBR_STHR14_REG (0x50020168)**

Bit	Mode	Symbol	Description	Reset
31:8	-	-	Reserved	0x0
7:0	R/W	SRBR_STHRx	Shadow Receive Buffer Register x: This is a shadow register for the RBR and has been allocated sixteen 32-	0x0

Bit	Mode	Symbol	Description	Reset
			<p>bit locations so as to accommodate burst accesses from the master. This register contains the data byte received on the serial input port (sin) in UART mode or the serial infrared input (sir_in) in infrared mode. The data in this register is valid only if the Data Ready (DR) bit in the Line status Register (LSR) is set. If FIFOs are disabled (FCR[0] set to zero), the data in the RBR must be read before the next data arrives, otherwise it will be overwritten, resulting in an overrun error. If FIFOs are enabled (FCR[0] set to one), this register accesses the head of the receive FIFO. If the receive FIFO is full and this register is not read before the next data character arrives, then the data already in the FIFO will be preserved but any incoming data will be lost. An overrun error will also occur. Shadow Transmit Holding Register 0: This is a shadow register for the THR and has been allocated sixteen 32-bit locations so as to accommodate burst accesses from the master. This register contains data to be transmitted on the serial output port (sout) in UART mode or the serial infrared output (sir_out_n) in infrared mode. Data should only be written to the THR when the THR Empty (THRE) bit (LSR[5]) is set. If FIFO's are disabled (FCR[0] set to zero) and THRE is set, writing a single character to the THR clears the THRE. Any additional writes to the THR before the THRE is set again causes the THR data to be overwritten. If FIFO's are enabled (FCR[0] set to one) and THRE is set, x number of characters of data may be written to the THR before the FIFO is full. The number x (default=16) is determined by the value of FIFO Depth that you set during configuration. Any attempt to write data when the FIFO is full results in the write data being lost.</p>	

Table 477: UART2_SRBR_STHR15_REG (0x5002016C)

Bit	Mode	Symbol	Description	Reset
31:8	-	-	Reserved	0x0
7:0	R/W	SRBR_STHRx	<p>Shadow Receive Buffer Register x: This is a shadow register for the RBR and has been allocated sixteen 32-bit locations so as to accommodate burst accesses from the master. This register contains the data byte received on the serial input port (sin) in UART mode or the serial infrared input (sir_in) in infrared mode. The data in this register is valid only if the Data Ready (DR) bit in the Line status Register (LSR) is set. If FIFOs are disabled (FCR[0] set to zero), the data in the RBR must be read before the next data arrives, otherwise it will be overwritten, resulting in an overrun error. If FIFOs are enabled (FCR[0] set to one), this register accesses the head of the receive FIFO. If the receive FIFO is full and this register is not read before the next data character arrives, then the data already in the FIFO will be preserved but any incoming data will be lost. An overrun error will also occur. Shadow Transmit Holding Register 0: This is a shadow register for the THR and has been allocated sixteen 32-bit locations so as to accommodate burst accesses from the master. This register contains data to be transmitted on the serial output port (sout) in</p>	0x0

Bit	Mode	Symbol	Description	Reset
			UART mode or the serial infrared output (sir_out_n) in infrared mode. Data should only be written to the THR when the THR Empty (THRE) bit (LSR[5]) is set. If FIFO's are disabled (FCR[0] set to zero) and THRE is set, writing a single character to the THR clears the THRE. Any additional writes to the THR before the THRE is set again causes the THR data to be overwritten. If FIFO's are enabled (FCR[0] set to one) and THRE is set, x number of characters of data may be written to the THR before the FIFO is full. The number x (default=16) is determined by the value of FIFO Depth that you set during configuration. Any attempt to write data when the FIFO is full results in the write data being lost.	

Table 478: **UART2_USR_REG (0x5002017C)**

Bit	Mode	Symbol	Description	Reset
31:5	-	-	Reserved	0x0
4	R	UART_RFF	Receive FIFO Full. This is used to indicate that the receive FIFO is completely full. 0 = Receive FIFO not full 1 = Receive FIFO Full This bit is cleared when the RX FIFO is no longer full.	0x0
3	R	UART_RFNE	Receive FIFO Not Empty. This is used to indicate that the receive FIFO contains one or more entries. 0 = Receive FIFO is empty 1 = Receive FIFO is not empty This bit is cleared when the RX FIFO is empty.	0x0
2	R	UART_TFE	Transmit FIFO Empty. This is used to indicate that the transmit FIFO is completely empty. 0 = Transmit FIFO is not empty 1 = Transmit FIFO is empty This bit is cleared when the TX FIFO is no longer empty.	0x1
1	R	UART_TFNF	Transmit FIFO Not Full. This is used to indicate that the transmit FIFO is not full. 0 = Transmit FIFO is full 1 = Transmit FIFO is not full This bit is cleared when the TX FIFO is full.	0x1
0	R	UART_BUSY	UART Busy. This indicates that a serial transfer is in progress, when cleared indicates that the DW_apb_uart is idle or inactive. 0 - DW_apb_uart is idle or inactive 1 - DW_apb_uart is busy (actively transferring data) Note that it is possible for the UART Busy bit to be cleared even though a new character may have been sent from another device. That is, if the DW_apb_uart has no data in the THR and RBR and there is no transmission in progress and a start bit of a new character has just reached the DW_apb_uart. This is due to the fact that a valid start is not seen until the middle of the bit period	0x0

Bit	Mode	Symbol	Description	Reset
			and this duration is dependent on the baud divisor that has been programmed. If a second system clock has been implemented (CLOCK_MODE == Enabled) the assertion of this bit will also be delayed by several cycles of the slower clock.	

Table 479: **UART2_TFL_REG** (0x50020180)

Bit	Mode	Symbol	Description	Reset
4:0	R	UART_TRANSMIT_FIFO_LEVEL	Transmit FIFO Level. This indicates the number of data entries in the transmit FIFO.	0x0

Table 480: **UART2_RFL_REG** (0x50020184)

Bit	Mode	Symbol	Description	Reset
4:0	R	UART_RECEIVE_FIFO_LEVEL	Receive FIFO Level. This indicates the number of data entries in the receive FIFO.	0x0

Table 481: **UART2_SRR_REG** (0x50020188)

Bit	Mode	Symbol	Description	Reset
31:3	-	-	Reserved	0x0
2	W	UART_XFR	XMIT FIFO Reset. This is a shadow register for the XMIT FIFO Reset bit (FCR[2]). This can be used to remove the burden on software having to store previously written FCR values (which are pretty static) just to reset the transmit FIFO. This resets the control portion of the transmit FIFO and treats the FIFO as empty. Note that this bit is 'self-clearing'. It is not necessary to clear this bit.	0x0
1	W	UART_RFR	RCVR FIFO Reset. This is a shadow register for the RCVR FIFO Reset bit (FCR[1]). This can be used to remove the burden on software having to store previously written FCR values (which are pretty static) just to reset the receive FIFO. This resets the control portion of the receive FIFO and treats the FIFO as empty. Note that this bit is 'self-clearing'. It is not necessary to clear this bit.	0x0
0	W	UART_UR	UART Reset. This asynchronously resets the UART Ctrl and synchronously removes the reset assertion. For a two clock implementation both pclk and sclk domains are reset.	0x0

Table 482: **UART2_SRTS_REG** (0x5002018C)

Bit	Mode	Symbol	Description	Reset
31:1	-	-	Reserved	0x0

Bit	Mode	Symbol	Description	Reset
0	R/W	UART_SHADOW_REQUEST_TO_SEND	<p>Shadow Request to Send.</p> <p>This is a shadow register for the RTS bit (MCR[1]), this can be used to remove the burden of having to performing a read-modify-write on the MCR. This is used to directly control the Request to Send (rts_n) output. The Request To Send (rts_n) output is used to inform the modem or data set that the UART Ctrl is ready to exchange data.</p> <p>When Auto RTS Flow Control is not enabled (MCR[5] = 0), the rts_n signal is set low by programming MCR[1] (RTS) to a high.</p> <p>In Auto Flow Control, (active MCR[5] = 1) and FIFOs enable (FCR[0] = 1), the rts_n output is controlled in the same way, but is also gated with the receiver FIFO threshold trigger (rts_n is inactive high when above the threshold).</p> <p>Note that in Loopback mode (MCR[4] = 1), the rts_n output is held inactive-high while the value of this location is internally looped back to an input.</p>	0x0

Table 483: **UART2_SBCR_REG** (0x50020190)

Bit	Mode	Symbol	Description	Reset
31:1	-	-	Reserved	0x0
0	R/W	UART_SHADOW_BREAK_CONTROL	<p>Shadow Break Control Bit.</p> <p>This is a shadow register for the Break bit (LCR[6]), this can be used to remove the burden of having to performing a read modify write on the LCR. This is used to cause a break condition to be transmitted to the receiving device.</p> <p>If set to one the serial output is forced to the spacing (logic 0) state. When not in Loopback Mode, as determined by MCR[4], the sout line is forced low until the Break bit is cleared.</p>	0x0

Table 484: **UART2_SDMAM_REG** (0x50020194)

Bit	Mode	Symbol	Description	Reset
31:1	-	-	Reserved	0x0
0	R/W	UART_SHADOW_DMA_MODE	<p>Shadow DMA Mode.</p> <p>This is a shadow register for the DMA mode bit (FCR[3]). This can be used to remove the burden of having to store the previously written value to the FCR in memory and having to mask this value so that only the DMA Mode bit gets updated. This determines the DMA signalling mode used for the dma_tx_req_n and dma_rx_req_n output signals.</p> <p>0 = mode 0 1 = mode 1</p>	0x0

Table 485: **UART2_SFE_REG** (0x50020198)

Bit	Mode	Symbol	Description	Reset
31:1	-	-	Reserved	0x0
0	R/W	UART_SHADOW_FIFO_ENABLE	Shadow FIFO Enable. This is a shadow register for the FIFO enable bit (FCR[0]). This can be used to remove the burden of having to store the previously written value to the FCR in memory and having to mask this value so that only the FIFO enable bit gets updated. This enables/disables the transmit (XMIT) and receive (RCVR) FIFOs. If this bit is set to zero (disabled) after being enabled then both the XMIT and RCVR controller portion of FIFOs are reset.	0x0

Table 486: **UART2_SRT_REG** (0x5002019C)

Bit	Mode	Symbol	Description	Reset
31:2	-	-	Reserved	0x0
1:0	R/W	UART_SHADOW_RCVR_TRIGGER	Shadow RCVR Trigger. This is a shadow register for the RCVR trigger bits (FCR[7:6]). This can be used to remove the burden of having to store the previously written value to the FCR in memory and having to mask this value so that only the RCVR trigger bit gets updated. This is used to select the trigger level in the receiver FIFO at which the Received Data Available Interrupt is generated. It also determines when the dma_rx_req_n signal is asserted when DMA Mode (FCR[3]) = 1. The following trigger levels are supported: 00 = 1 character in the FIFO 01 = FIFO ¼ full 10 = FIFO ½ full 11 = FIFO 2 less than full	0x0

Table 487: **UART2_STET_REG** (0x500201A0)

Bit	Mode	Symbol	Description	Reset
31:2	-	-	Reserved	0x0
1:0	R/W	UART_SHADOW_TX_EMPTY_TRIGGER	Shadow TX Empty Trigger. This is a shadow register for the TX empty trigger bits (FCR[5:4]). This can be used to remove the burden of having to store the previously written value to the FCR in memory and having to mask this value so that only the TX empty trigger bit gets updated. This is used to select the empty threshold level at which the THRE Interrupts are generated when the mode is active. The following trigger levels are supported: 00 = FIFO empty 01 = 2 characters in the FIFO 10 = FIFO ¼ full 11 = FIFO ½ full	0x0

Table 488: **UART2_HTX_REG** (0x500201A4)

Bit	Mode	Symbol	Description	Reset
31:1	-	-	Reserved	0x0
0	R/W	UART_HALT_TX	This register is use to halt transmissions, so that the transmit FIFO can be filled by the master when FIFOs are implemented and enabled. 0 = Halt TX disabled 1 = Halt TX enabled Note, if FIFOs are not enabled, the setting of the halt TX register has no effect on operation.	0x0

Table 489: **UART2_DMASA_REG** (0x500201A8)

Bit	Mode	Symbol	Description	Reset
31:1	-	-	Reserved	0x0
0	W	UART_DMASA	This register is use to perform DMA software acknowledge if a transfer needs to be terminated due to an error condition. For example, if the DMA disables the channel, then the DW_apb_uart should clear its request. This will cause the TX request, TX single, RX request and RX single signals to de-assert. Note that this bit is 'self-clearing' and it is not necessary to clear this bit.	0x0

Table 490: **UART2_DLF_REG** (0x500201C0)

Bit	Mode	Symbol	Description	Reset
31:4	-	-	Reserved	0x0
3:0	R/W	UART_DLF	The fractional value is added to integer value set by DLH, DLL. Fractional value is equal UART_DLF/16	0x0

Table 491: **UART2_RAR_REG** (0x500201C4)

Bit	Mode	Symbol	Description	Reset
7:0	R/W	UART_RAR	This is an address matching register during receive mode. If the 9-th bit is set in the incoming character then the remaining 8-bits will be checked against this register value. If the match happens then sub-sequent characters with 9-th bit set to 0 will be treated as data byte until the next address byte is received. Note: - This register is applicable only when 'ADDR_MATCH'(LCR_EXT[1] and 'DLS_E' (LCR_EXT[0]) bits are set to 1. RAR should be programmed only when UART is not busy.	0x0

Table 492: **UART2_TAR_REG** (0x500201C8)

Bit	Mode	Symbol	Description	Reset
7:0	R/W	UART_TAR	This is an address matching register during transmit mode. If DLS_E (LCR_EXT[0]) bit is enabled, then uart	0x0

Bit	Mode	Symbol	Description	Reset
			<p>will send the 9-bit character with 9-th bit set to 1 and remaining 8-bit address will be sent from this register provided 'SEND_ADDR' (LCR_EXT[2]) bit is set to 1.</p> <p>Note:</p> <ul style="list-style-type: none"> - This register is used only to send the address. The normal data should be sent by programming THR register. - Once the address is started to send on the DW_apb_uart serial lane, then 'SEND_ADDR' bit will be auto-cleared by the hardware. 	

Table 493: UART2_LCR_EXT (0x500201CC)

Bit	Mode	Symbol	Description	Reset
3	R/W	UART_TRANSMIT_MODE	<p>Transmit mode control bit. This bit is used to control the type of transmit mode during 9-bit data transfers.</p> <p>1 = In this mode of operation, Transmit Holding Register (THR) and Shadow Transmit Holding Register (STHR) are 9-bit wide. The user needs to ensure that the THR/STHR register is written correctly for address/data.</p> <p>Address: 9th bit is set to 1, Data : 9th bit is set to 0.</p> <p>Note: Transmit address register (TAR) is not applicable in this mode of operation.</p> <p>0 = In this mode of operation, Transmit Holding Register (THR) and Shadow Transmit Holding register (STHR) are 8-bit wide. The user needs to program the address into Transmit Address Register (TAR) and data into the THR/STHR register. SEND_ADDR bit is used as a control knob to indicate the uart on when to send the address.</p>	0x0
2	R/W	UART_SEND_ADDR	<p>Send address control bit. This bit is used as a control knob for the user to determine when to send the address during transmit mode.</p> <p>1 = 9-bit character will be transmitted with 9-th bit set to 1 and the remaining 8-bits will match to what is being programmed in 'Transmit Address Register'.</p> <p>0 = 9-bit character will be transmitted with 9-th bit set to 0 and the remaining 8-bits will be taken from the TXFIFO which is programmed through 8-bit wide THR/STHR register.</p> <p>Note:</p> <ol style="list-style-type: none"> 1. This bit is auto-cleared by the hardware, after sending out the address character. User is not expected to program this bit to 0. 2. This field is applicable only when DLS_E bit is set to 1 and TRANSMIT_MODE is set to 0. 	0x0
1	R/W	UART_ADDR_MATCH	<p>Address Match Mode. This bit is used to enable the address match feature during receive.</p> <p>1 = Address match mode; uart will wait until the incoming character with 9-th bit set to 1. And further checks to see if the address matches with what is programmed in 'Receive Address Match Register'. If match is found, then sub-sequent characters will be</p>	0x0

Bit	Mode	Symbol	Description	Reset
			<p>treated as valid data and DW_apb_uart starts receiving data.</p> <p>0 = Normal mode; DW_apb_uart will start to receive the data and 9-bit character will be formed and written into the receive RXFIFO. User is responsible to read the data and differentiate b/n address and data.</p> <p>Note: This field is applicable only when DLS_E is set to 1.</p>	
0	R/W	UART_DLS_E	Extension for DLS. This bit is used to enable 9-bit data for transmit and receive transfers.	0x0

Table 494: **UART2_UCV_REG (0x500201F8)**

Bit	Mode	Symbol	Description	Reset
31:0	R	UART_UCV	Component Version	0x343031 2A

Table 495: **UART2_CTR_REG (0x500201FC)**

Bit	Mode	Symbol	Description	Reset
31:0	R	UART_CTR	Component Type Register	0x445701 10

Table 496: **UART3_RBR_THR_DLL_REG (0x50020200)**

Bit	Mode	Symbol	Description	Reset
8	R/W	RBR_THR_9BIT	When 9BIT_DATA_EN, On read :Receive Buffer bit 8 - On write Transmit Buffer bit 8 when LCR_EXT[3]=1	0x0
7:0	R/W	RBR_THR_DLL	<p>Receive Buffer Register: (RBR).</p> <p>This register contains the data byte received on the serial input port (sin) in UART mode or the serial infrared input (sir_in) in infrared mode. The data in this register is valid only if the Data Ready (DR) bit in the Line status Register (LSR) is set. If FIFOs are disabled (FCR[0] set to zero), the data in the RBR must be read before the next data arrives, otherwise it will be overwritten, resulting in an overrun error. If FIFOs are enabled (FCR[0] set to one), this register accesses the head of the receive FIFO. If the receive FIFO is full and this register is not read before the next data character arrives, then the data already in the FIFO will be preserved but any incoming data will be lost. An overrun error will also occur.</p> <p>Transmit Holding Register: (THR)</p> <p>This register contains data to be transmitted on the serial output port (sout) in UART mode or the serial infrared output (sir_out_n) in infrared mode. Data should only be written to the THR when the THR Empty (THRE) bit (LSR[5]) is set. If FIFO's are disabled (FCR[0] set to zero) and THRE is set, writing a single character to the THR clears the THRE. Any additional writes to the THR before the THRE is set again causes the THR data to be overwritten. If FIFO's are enabled (FCR[0] set to one) and THRE is set, x number of characters of data may be</p>	0x0

Bit	Mode	Symbol	Description	Reset
			<p>written to the THR before the FIFO is full. The number x (default=16) is determined by the value of FIFO Depth that you set during configuration. Any attempt to write data when the FIFO is full results in the write data being lost.</p> <p>Divisor Latch (Low): (DLL)</p> <p>This register makes up the lower 8-bits of a 16-bit, read/write, Divisor Latch register that contains the baud rate divisor for the UART. This register may only be accessed when the DLAB bit (LCR[7]) is set. The output baud rate is equal to the serial clock (sclk) frequency divided by sixteen times the value of the baud rate divisor, as follows:</p> $\text{baud rate} = (\text{serial clock freq}) / (16 * \text{divisor})$ <p>Note that with the Divisor Latch Registers (DLL and DLH) set to zero, the baud clock is disabled and no serial communications will occur. Also, once the DLL is set, at least 8 clock cycles of the slowest DW_apb_uart clock should be allowed to pass before transmitting or receiving data.</p> <p>Divisor Latch (High): (DLH) (Note: This register is placed in UART_IER_DLH_REG with offset 0x4)</p> <p>Upper 8-bits of a 16-bit, read/write, Divisor Latch register that contains the baud rate divisor for the UART. This register may be accessed only when the DLAB bit (LCR[7]) is set. The output baud rate is equal to the serial clock frequency divided by sixteen times the value of the baud rate divisor, as follows:</p> $\text{baud rate} = (\text{serial clock freq}) / (16 * \text{divisor}).$ <p>Note that with the Divisor Latch Registers (DLL and DLH) set to zero, the baud clock is disabled and no serial communications occur. Also, once the DLH is set, at least 8 clock cycles of the slowest DW_apb_uart clock should be allowed to pass before transmitting or receiving data.</p>	

Table 497: **UART3_IER_DLH_REG (0x50020204)**

Bit	Mode	Symbol	Description	Reset
31:8	-	-	Reserved	0x0
7	R/W	PTIME_DLH7	<p>Interrupt Enable Register: PTIME, Programmable THRE Interrupt Mode Enable. This is used to enable/disable the generation of THRE Interrupt. 0 = disabled 1 = enabled</p> <p>Divisor Latch (High): Bit[7] of the 8 bit DLH register.</p>	0x0
6:5	R/W	DLH6_5	Divisor Latch (High): Bit[6:5] of the 8 bit DLH register	0x0
4	R/W	ELCOLR_DLH4	<p>Interrupt Enable Register: ELCOLR (read only), this bit controls the method for clearing the status in the LSR register. This is applicable only for Overrun Error, Parity Error, Framing Error, and Break Interrupt status bits.</p> <p>0 = LSR status bits are cleared either on reading Rx FIFO (RBR Read) or On reading LSR register.</p> <p>Divisor Latch (High): Bit[4] of the 8 bit DLH register</p>	0x0
3	R/W	EDSSI_DLH3	Interrupt Enable Register: EDSSI, Enable Modem Status Interrupt. This is used to enable/disable the generation	0x0

Bit	Mode	Symbol	Description	Reset
			of Modem Status Interrupt. This is the fourth highest priority interrupt. 0 = disabled 1 = enabled Divisor Latch (High): Bit[3] of the 8 bit DLH register	
2	R/W	ELSI_DLH2	Interrupt Enable Register: ELSI, Enable Receiver Line Status Interrupt. This is used to enable/disable the generation of Receiver Line Status Interrupt. This is the highest priority interrupt. 0 = disabled 1 = enabled Divisor Latch (High): Bit[2] of the 8 bit DLH register.	0x0
1	R/W	ETBEI_DLH1	Interrupt Enable Register: ETBEI, Enable Transmit Holding Register Empty Interrupt. This is used to enable/disable the generation of Transmitter Holding Register Empty Interrupt. This is the third highest priority interrupt. 0 = disabled 1 = enabled Divisor Latch (High): Bit[1] of the 8 bit DLH register.	0x0
0	R/W	ERBFI_DLH0	Interrupt Enable Register: ERBFI, Enable Received Data Available Interrupt. This is used to enable/disable the generation of Received Data Available Interrupt and the Character Timeout Interrupt (if in FIFO mode and FIFO's enabled). These are the second highest priority interrupts. 0 = disabled 1 = enabled Divisor Latch (High): Bit[0] of the 8 bit DLH register.	0x0

Table 498: **UART3_IIR_FCR_REG (0x50020208)**

Bit	Mode	Symbol	Description	Reset
31:8	-	-	Reserved	0x0
7:0	R/W	IIR_FCR	On Read Interrupt Identification Register : Bits[7:6], FIFO's Enabled (or FIFOSE): This is used to indicate whether the FIFO's are enabled or disabled. 00 = disabled. 11 = enabled. Bits[5:4],Reserved Bits[3:0], Interrupt ID (or IID): This indicates the highest priority pending interrupt which can be one of the following types:0001 = no interrupt pending. 0010 = THR empty. 0100 = received data available. 0110 = receiver line status. 0111 = busy detect. 1100 = character timeout. On Write FIFO Control Register Bits[7:6], RCVR Trigger (or RT):. This is used to select the trigger level in the receiver FIFO at which the Received Data Available Interrupt will be generated. In auto flow control mode it is used to determine when the rts_n signal will be de-asserted. It also determines when the dma_rx_req_n signal will be asserted when in certain modes of operation. The following trigger levels are supported: 00 = 1 character in the FIFO 01 = FIFO 1/4 full 10 = FIFO 1/2 full 11 = FIFO 2 less than full Bits[5:4], TX Empty Trigger (or TET): This is used to select the empty threshold level at which the THRE Interrupts will be generated when the mode is active. It also determines when the dma_tx_req_n signal will be asserted when in certain modes of operation. The following trigger levels are supported: 00 = FIFO empty 01 = 2 characters in the FIFO 10 = FIFO 1/4 full 11 = FIFO 1/2 full	0x1

Bit	Mode	Symbol	Description	Reset
			<p>Bit[3], DMA Mode (or DMAM): This determines the DMA signalling mode used for the dma_tx_req_n and dma_rx_req_n output signals. 0 = mode 0 1 = mode 1</p> <p>Bit[2], XMIT FIFO Reset (or XFIFOR): This resets the control portion of the transmit FIFO and treats the FIFO as empty. Note that this bit is 'self-clearing' and it is not necessary to clear this bit.</p> <p>Bit[1], RCVR FIFO Reset (or RFIFOR): This resets the control portion of the receive FIFO and treats the FIFO as empty. Note that this bit is 'self-clearing' and it is not necessary to clear this bit.</p> <p>Bit[0], FIFO Enable (or FIFOE): This enables/disables the transmit (XMIT) and receive (RCVR) FIFO's. Whenever the value of this bit is changed both the XMIT and RCVR controller portion of FIFO's will be reset.</p>	

Table 499: UART3_LCR_REG (0x5002020C)

Bit	Mode	Symbol	Description	Reset
31:8	-	-	Reserved	0x0
7	R/W	UART_DLAB	<p>Divisor Latch Access Bit.</p> <p>This bit is used to enable reading and writing of the Divisor Latch register (DLL and DLH) to set the baud rate of the UART.</p> <p>This bit must be cleared after initial baud rate setup in order to access other registers.</p>	0x0
6	R/W	UART_BC	<p>Break Control Bit.</p> <p>This is used to cause a break condition to be transmitted to the receiving device. If set to one the serial output is forced to the spacing (logic 0) state. When not in Loopback Mode, as determined by MCR[4], the serial line is forced low until the Break bit is cleared.</p>	0x0
5	R/W	UART_SP	<p>Stick Parity. (writeable only when UART is not busy (USR[0] is 0); otherwise always writable and always readable. This bit is used to force parity value. When PEN, EPS and Stick Parity are set to 1, the parity bit is transmitted and checked as logic 0. If PEN and Stick Parity are set to 1 and EPS is a logic 0, then parity bit is transmitted and checked as a logic 1. If this bit is set to 0, Stick Parity is disabled.</p>	0x0
4	R/W	UART_EPS	<p>Even Parity Select. Writeable only when UART is not busy (USR[0] is zero).</p> <p>This is used to select between even and odd parity, when parity is enabled (PEN set to one). If set to one, an even number of logic 1s is transmitted or checked. If set to zero, an odd number of logic 1s is transmitted or checked.</p>	0x0
3	R/W	UART_PEN	<p>Parity Enable. Writeable only when UART is not busy (USR[0] is zero)</p> <p>This bit is used to enable and disable parity generation and detection in transmitted and received serial character respectively.</p> <p>0 = parity disabled 1 = parity enabled</p>	0x0

Bit	Mode	Symbol	Description	Reset
2	R/W	UART_STOP	<p>Number of stop bits.</p> <p>This is used to select the number of stop bits per character that the peripheral transmits and receives. If set to zero, one stop bit is transmitted in the serial data. If set to one and the data bits are set to 5 (LCR[1:0] set to zero) one and a half stop bits is transmitted. Otherwise, two stop bits are transmitted. Note that regardless of the number of stop bits selected, the receiver checks only the first stop bit.</p> <p>0 = 1 stop bit 1 = 1.5 stop bits when DLS (LCR[1:0]) is zero, else 2 stop bit</p>	0x0
1:0	R/W	UART_DLS	<p>Data Length Select.</p> <p>This is used to select the number of data bits per character that the peripheral transmits and receives. The number of bit that may be selected areas follows:</p> <p>00 = 5 bits 01 = 6 bits 10 = 7 bits 11 = 8 bits</p>	0x0

Table 500: UART3_MCR_REG (0x50020210)

Bit	Mode	Symbol	Description	Reset
31:7	-	-	Reserved	0x0
6	R/W	-	Reserved	0x0
5	R/W	UART_AFCE	<p>Auto Flow Control Enable.</p> <p>When FIFOs are enabled and the Auto Flow Control Enable (AFCE) bit is set, Auto Flow Control features are enabled as described in "Auto Flow Control".</p> <p>0 = Auto Flow Control Mode disabled 1 = Auto Flow Control Mode enabled</p>	0x0
4	R/W	UART_LB	<p>LoopBack Bit.</p> <p>This is used to put the UART into a diagnostic mode for test purposes.</p> <p>Data on the sout line is held high, while serial data output is looped back to the sin line, internally. In this mode all the interrupts are fully functional. Also, in loopback mode, the modem control inputs (dsr_n, cts_n, ri_n, dcd_n) are disconnected and the modem control outputs (dtr_n, rts_n) are looped back to the inputs, internally.</p>	0x0
3	R/W	-	Reserved	0x0
2	R/W	-	Reserved	0x0
1	R/W	UART_RTS	<p>Request to Send.</p> <p>This is used to directly control the Request to Send (rts_n) output. The Request To Send (rts_n) output is used to inform the modem or data set that the UART is ready to exchange data.</p> <p>When Auto RTS Flow Control is not enabled (MCR[5] set to zero), the rts_n signal is set low by programming</p>	0x0

Bit	Mode	Symbol	Description	Reset
			MCR[1] (RTS) to a high. In Auto Flow Control, active (MCR[5] set to one) and FIFOs enable (FCR[0] set to one), the rts_n output is controlled in the same way, but is also gated with the receiver FIFO threshold trigger (rts_n is inactive high when above the threshold). The rts_n signal is de-asserted when MCR[1] is set low. Note that in Loopback mode (MCR[4] set to one), the rts_n output is held inactive high while the value of this location is internally looped back to an input.	
0	R/W	-	Reserved	0x0

Table 501: **UART3_LSR_REG (0x50020214)**

Bit	Mode	Symbol	Description	Reset
8	R	UART_ADDR_RCVD	Address Received Bit. If 9Bit data mode (LCR_EXT[0]=1) is enabled, this bit is used to indicate the 9th bit of the receive data is set to 1. This bit can also be used to indicate whether the incoming character is address or data. 1 = Indicates the character is address. 0 = Indicates the character is data. In the FIFO mode, since the 9th bit is associated with a character received, it is revealed when the character with the 9th bit set to 1 is at the top of the FIFO. Reading the LSR clears the 9BIT. Note: User needs to ensure that interrupt gets cleared (reading LSR register) before the next address byte arrives. If there is a delay in clearing the interrupt, then Software will not be able to distinguish between multiple address related interrupt.	0x0
7	R	UART_RFE	Receiver FIFO Error bit. This bit is only relevant when FIFOs are enabled (FCR[0] set to one). This is used to indicate if there is at least one parity error, framing error, or break indication in the FIFO. 0 = no error in RX FIFO 1 = error in RX FIFO This bit is cleared when the LSR is read and the character with the error is at the top of the receiver FIFO and there are no subsequent errors in the FIFO.	0x0
6	R	UART_TEMT	Transmitter Empty bit. If FIFOs enabled (FCR[0] set to one), this bit is set whenever the Transmitter Shift Register and the FIFO are both empty. If FIFOs are disabled, this bit is set whenever the Transmitter Holding Register and the Transmitter Shift Register are both empty.	0x1
5	R	UART_THRE	Transmit Holding Register Empty bit. If THRE mode is disabled (IER[7] set to zero) and regardless of FIFO's being implemented/enabled or not, this bit indicates that the THR or TX FIFO is empty. This bit is set whenever data is transferred from the THR or TX FIFO to the transmitter shift register and no new data has been written to the THR or TX FIFO. This also causes a THRE Interrupt to occur, if the THRE Interrupt	0x1

Bit	Mode	Symbol	Description	Reset
			is enabled. If both modes are active (IER[7] set to one and FCR[0] set to one respectively), the functionality is switched to indicate the transmitter FIFO is full, and no longer controls THRE interrupts, which are then controlled by the FCR[5:4] threshold setting.	
4	R	UART_BI	<p>Break Interrupt bit.</p> <p>This is used to indicate the detection of a break sequence on the serial input data.</p> <p>If in UART mode (SIR_MODE == Disabled), it is set whenever the serial input, sin, is held in a logic '0' state for longer than the sum of start time + data bits + parity + stop bits.</p> <p>In the FIFO mode, the character associated with the break condition is carried through the FIFO and is revealed when the character is at the top of the FIFO.</p> <p>Reading the LSR clears the BI bit. In the non-FIFO mode, the BI indication occurs immediately and persists until the LSR is read.</p>	0x0
3	R	UART_FE	<p>Framing Error bit.</p> <p>This is used to indicate the occurrence of a framing error in the receiver. A framing error occurs when the receiver does not detect a valid STOP bit in the received data.</p> <p>In the FIFO mode, since the framing error is associated with a character received, it is revealed when the character with the framing error is at the top of the FIFO.</p> <p>When a framing error occurs, the UART tries to resynchronize. It does this by assuming that the error was due to the start bit of the next character and then continues receiving the other bit i.e. data, and/or parity and stop. It should be noted that the Framing Error (FE) bit (LSR[3]) is set if a break interrupt has occurred, as indicated by Break Interrupt (BI) bit (LSR[4]).</p> <p>0 = no framing error 1 = framing error</p> <p>Reading the LSR clears the FE bit.</p>	0x0
2	R	UART_PE	<p>Parity Error bit.</p> <p>This is used to indicate the occurrence of a parity error in the receiver if the Parity Enable (PEN) bit (LCR[3]) is set.</p> <p>In the FIFO mode, since the parity error is associated with a character received, it is revealed when the character with the parity error arrives at the top of the FIFO.</p> <p>It should be noted that the Parity Error (PE) bit (LSR[2]) is set if a break interrupt has occurred, as indicated by Break Interrupt (BI) bit (LSR[4]).</p> <p>0 = no parity error 1 = parity error</p> <p>Reading the LSR clears the PE bit.</p>	0x0
1	R	UART_OE	<p>Overrun error bit.</p> <p>This is used to indicate the occurrence of an overrun error.</p> <p>This occurs if a new data character was received before the previous data was read.</p>	0x0

Bit	Mode	Symbol	Description	Reset
			In the non-FIFO mode, the OE bit is set when a new character arrives in the receiver before the previous character was read from the RBR. When this happens, the data in the RBR is overwritten. In the FIFO mode, an overrun error occurs when the FIFO is full and a new character arrives at the receiver. The data in the FIFO is retained and the data in the receive shift register is lost. 0 = no overrun error 1 = overrun error Reading the LSR clears the OE bit.	
0	R	UART_DR	Data Ready bit. This is used to indicate that the receiver contains at least one character in the RBR or the receiver FIFO. 0 = no data ready 1 = data ready This bit is cleared when the RBR is read in non-FIFO mode, or when the receiver FIFO is empty, in FIFO mode.	0x0

Table 502: **UART3_MSR_REG** (0x50020218)

Bit	Mode	Symbol	Description	Reset
31:5	-	-	Reserved	0x0
4	R	UART_CTS	Clear to Send. This is used to indicate the current state of the modem control line cts_n. This bit is the complement of cts_n. When the Clear to Send input (cts_n) is asserted it is an indication that the modem or data set is ready to exchange data with the UART Ctrl. 0 = cts_n input is de-asserted (logic 1) 1 = cts_n input is asserted (logic 0) In Loopback Mode (MCR[4] = 1), CTS is the same as MCR[1] (RTS).	0x1
3:1	-	-	Reserved	0x0
0	R	UART_DCTS	Delta Clear to Send. This is used to indicate that the modem control line cts_n has changed since the last time the MSR was read. 0 = no change on cts_n since last read of MSR 1 = change on cts_n since last read of MSR Reading the MSR clears the DCTS bit. In Loopback Mode (MCR[4] = 1), DCTS reflects changes on MCR[1] (RTS). Note, if the DCTS bit is not set and the cts_n signal is asserted (low) and a reset occurs (software or otherwise), then the DCTS bit is set when the reset is removed if the cts_n signal remains asserted.	0x0

Table 503: **UART3_CONFIG_REG (0x5002021C)**

Bit	Mode	Symbol	Description	Reset
31:8	-	-	Reserved	0x0
7:3	R/W	ISO7816_SCRATCH_PAD	This register is for programmers to use as a temporary storage space. It has no defined purpose in the UART Ctrl.	0x0
2	R/W	ISO7816_ENABLE	0 : Normal Uart 1 : ISO7816 Enabled	0x0
1	R/W	ISO7816_ERR_SIG_EN	0 : Error Signal feature disabled 1 : Error Signal feature enabled	0x0
0	R/W	ISO7816_CONVENTION	0 : Direct convention 1 : Inverse convention	0x0

Table 504: **UART3_SRBR_STHR0_REG (0x50020230)**

Bit	Mode	Symbol	Description	Reset
31:8	-	-	Reserved	0x0
7:0	R/W	SRBR_STHRx	Shadow Receive Buffer Register x: This is a shadow register for the RBR and has been allocated sixteen 32-bit locations so as to accommodate burst accesses from the master. This register contains the data byte received on the serial input port (sin) in UART mode or the serial infrared input (sir_in) in infrared mode. The data in this register is valid only if the Data Ready (DR) bit in the Line status Register (LSR) is set. If FIFOs are disabled (FCR[0] set to zero), the data in the RBR must be read before the next data arrives, otherwise it will be overwritten, resulting in an overrun error. If FIFOs are enabled (FCR[0] set to one), this register accesses the head of the receive FIFO. If the receive FIFO is full and this register is not read before the next data character arrives, then the data already in the FIFO will be preserved but any incoming data will be lost. An overrun error will also occur. Shadow Transmit Holding Register 0: This is a shadow register for the THR and has been allocated sixteen 32-bit locations so as to accommodate burst accesses from the master. This register contains data to be transmitted on the serial output port (sout) in UART mode or the serial infrared output (sir_out_n) in infrared mode. Data should only be written to the THR when the THR Empty (THRE) bit (LSR[5]) is set. If FIFO's are disabled (FCR[0] set to zero) and THRE is set, writing a single character to the THR clears the THRE. Any additional writes to the THR before the THRE is set again causes the THR data to be overwritten. If FIFO's are enabled (FCR[0] set to one) and THRE is set, x number of characters of data may be written to the THR before the FIFO is full. The number x (default=16) is determined by the value of FIFO Depth that you set during configuration. Any attempt to write data when the FIFO is full results in the write data being lost.	0x0

Table 505: **UART3_SRBR_STHR1_REG (0x50020234)**

Bit	Mode	Symbol	Description	Reset
31:8	-	-	Reserved	0x0
7:0	R/W	SRBR_STHRx	Shadow Receive Buffer Register x: This is a shadow register for the RBR and has been allocated sixteen 32-bit locations so as to accommodate burst accesses from the master. This register contains the data byte received on the serial input port (sin) in UART mode or the serial infrared input (sir_in) in infrared mode. The data in this register is valid only if the Data Ready (DR) bit in the Line status Register (LSR) is set. If FIFOs are disabled (FCR[0] set to zero), the data in the RBR must be read before the next data arrives, otherwise it will be overwritten, resulting in an overrun error. If FIFOs are enabled (FCR[0] set to one), this register accesses the head of the receive FIFO. If the receive FIFO is full and this register is not read before the next data character arrives, then the data already in the FIFO will be preserved but any incoming data will be lost. An overrun error will also occur. Shadow Transmit Holding Register 0: This is a shadow register for the THR and has been allocated sixteen 32-bit locations so as to accommodate burst accesses from the master. This register contains data to be transmitted on the serial output port (sout) in UART mode or the serial infrared output (sir_out_n) in infrared mode. Data should only be written to the THR when the THR Empty (THRE) bit (LSR[5]) is set. If FIFO's are disabled (FCR[0] set to zero) and THRE is set, writing a single character to the THR clears the THRE. Any additional writes to the THR before the THRE is set again causes the THR data to be overwritten. If FIFO's are enabled (FCR[0] set to one) and THRE is set, x number of characters of data may be written to the THR before the FIFO is full. The number x (default=16) is determined by the value of FIFO Depth that you set during configuration. Any attempt to write data when the FIFO is full results in the write data being lost.	0x0

Table 506: **UART3_SRBR_STHR2_REG (0x50020238)**

Bit	Mode	Symbol	Description	Reset
31:8	-	-	Reserved	0x0
7:0	R/W	SRBR_STHRx	Shadow Receive Buffer Register x: This is a shadow register for the RBR and has been allocated sixteen 32-bit locations so as to accommodate burst accesses from the master. This register contains the data byte received on the serial input port (sin) in UART mode or the serial infrared input (sir_in) in infrared mode. The data in this register is valid only if the Data Ready (DR) bit in the Line status Register (LSR) is set. If FIFOs are disabled (FCR[0] set to zero), the data in the RBR must be read before the next data arrives, otherwise it will be overwritten, resulting in an overrun error. If FIFOs are enabled (FCR[0] set to one), this register accesses the head of the receive FIFO. If the receive FIFO is full and this register is not read before the next data character arrives, then the data already in the FIFO will be preserved but any incoming data will be lost. An overrun	0x0

Bit	Mode	Symbol	Description	Reset
			error will also occur. Shadow Transmit Holding Register 0: This is a shadow register for the THR and has been allocated sixteen 32-bit locations so as to accommodate burst accesses from the master. This register contains data to be transmitted on the serial output port (sout) in UART mode or the serial infrared output (sir_out_n) in infrared mode. Data should only be written to the THR when the THR Empty (THRE) bit (LSR[5]) is set. If FIFO's are disabled (FCR[0] set to zero) and THRE is set, writing a single character to the THR clears the THRE. Any additional writes to the THR before the THRE is set again causes the THR data to be overwritten. If FIFO's are enabled (FCR[0] set to one) and THRE is set, x number of characters of data may be written to the THR before the FIFO is full. The number x (default=16) is determined by the value of FIFO Depth that you set during configuration. Any attempt to write data when the FIFO is full results in the write data being lost.	

Table 507: **UART3_SRBR_STHR3_REG (0x5002023C)**

Bit	Mode	Symbol	Description	Reset
31:8	-	-	Reserved	0x0
7:0	R/W	SRBR_STHRx	Shadow Receive Buffer Register x: This is a shadow register for the RBR and has been allocated sixteen 32-bit locations so as to accommodate burst accesses from the master. This register contains the data byte received on the serial input port (sin) in UART mode or the serial infrared input (sir_in) in infrared mode. The data in this register is valid only if the Data Ready (DR) bit in the Line status Register (LSR) is set. If FIFOs are disabled (FCR[0] set to zero), the data in the RBR must be read before the next data arrives, otherwise it will be overwritten, resulting in an overrun error. If FIFOs are enabled (FCR[0] set to one), this register accesses the head of the receive FIFO. If the receive FIFO is full and this register is not read before the next data character arrives, then the data already in the FIFO will be preserved but any incoming data will be lost. An overrun error will also occur. Shadow Transmit Holding Register 0: This is a shadow register for the THR and has been allocated sixteen 32-bit locations so as to accommodate burst accesses from the master. This register contains data to be transmitted on the serial output port (sout) in UART mode or the serial infrared output (sir_out_n) in infrared mode. Data should only be written to the THR when the THR Empty (THRE) bit (LSR[5]) is set. If FIFO's are disabled (FCR[0] set to zero) and THRE is set, writing a single character to the THR clears the THRE. Any additional writes to the THR before the THRE is set again causes the THR data to be overwritten. If FIFO's are enabled (FCR[0] set to one) and THRE is set, x number of characters of data may be written to the THR before the FIFO is full. The number x (default=16) is determined by the value of FIFO Depth that you set during configuration. Any attempt to write data when the FIFO is full results in the write data being lost.	0x0

Table 508: **UART3_SRBR_STHR4_REG (0x50020240)**

Bit	Mode	Symbol	Description	Reset
31:8	-	-	Reserved	0x0
7:0	R/W	SRBR_STHRx	Shadow Receive Buffer Register x: This is a shadow register for the RBR and has been allocated sixteen 32-bit locations so as to accommodate burst accesses from the master. This register contains the data byte received on the serial input port (sin) in UART mode or the serial infrared input (sir_in) in infrared mode. The data in this register is valid only if the Data Ready (DR) bit in the Line status Register (LSR) is set. If FIFOs are disabled (FCR[0] set to zero), the data in the RBR must be read before the next data arrives, otherwise it will be overwritten, resulting in an overrun error. If FIFOs are enabled (FCR[0] set to one), this register accesses the head of the receive FIFO. If the receive FIFO is full and this register is not read before the next data character arrives, then the data already in the FIFO will be preserved but any incoming data will be lost. An overrun error will also occur. Shadow Transmit Holding Register 0: This is a shadow register for the THR and has been allocated sixteen 32-bit locations so as to accommodate burst accesses from the master. This register contains data to be transmitted on the serial output port (sout) in UART mode or the serial infrared output (sir_out_n) in infrared mode. Data should only be written to the THR when the THR Empty (THRE) bit (LSR[5]) is set. If FIFO's are disabled (FCR[0] set to zero) and THRE is set, writing a single character to the THR clears the THRE. Any additional writes to the THR before the THRE is set again causes the THR data to be overwritten. If FIFO's are enabled (FCR[0] set to one) and THRE is set, x number of characters of data may be written to the THR before the FIFO is full. The number x (default=16) is determined by the value of FIFO Depth that you set during configuration. Any attempt to write data when the FIFO is full results in the write data being lost.	0x0

Table 509: **UART3_SRBR_STHR5_REG (0x50020244)**

Bit	Mode	Symbol	Description	Reset
31:8	-	-	Reserved	0x0
7:0	R/W	SRBR_STHRx	Shadow Receive Buffer Register x: This is a shadow register for the RBR and has been allocated sixteen 32-bit locations so as to accommodate burst accesses from the master. This register contains the data byte received on the serial input port (sin) in UART mode or the serial infrared input (sir_in) in infrared mode. The data in this register is valid only if the Data Ready (DR) bit in the Line status Register (LSR) is set. If FIFOs are disabled (FCR[0] set to zero), the data in the RBR must be read before the next data arrives, otherwise it will be overwritten, resulting in an overrun error. If FIFOs are enabled (FCR[0] set to one), this register accesses the head of the receive FIFO. If the receive FIFO is full and this register is not read before the next data character	0x0

Bit	Mode	Symbol	Description	Reset
			arrives, then the data already in the FIFO will be preserved but any incoming data will be lost. An overrun error will also occur. Shadow Transmit Holding Register 0: This is a shadow register for the THR and has been allocated sixteen 32-bit locations so as to accommodate burst accesses from the master. This register contains data to be transmitted on the serial output port (sout) in UART mode or the serial infrared output (sir_out_n) in infrared mode. Data should only be written to the THR when the THR Empty (THRE) bit (LSR[5]) is set. If FIFO's are disabled (FCR[0] set to zero) and THRE is set, writing a single character to the THR clears the THRE. Any additional writes to the THR before the THRE is set again causes the THR data to be overwritten. If FIFO's are enabled (FCR[0] set to one) and THRE is set, x number of characters of data may be written to the THR before the FIFO is full. The number x (default=16) is determined by the value of FIFO Depth that you set during configuration. Any attempt to write data when the FIFO is full results in the write data being lost.	

Table 510: UART3_SRBR_STHR6_REG (0x50020248)

Bit	Mode	Symbol	Description	Reset
31:8	-	-	Reserved	0x0
7:0	R/W	SRBR_STHRx	Shadow Receive Buffer Register x: This is a shadow register for the RBR and has been allocated sixteen 32-bit locations so as to accommodate burst accesses from the master. This register contains the data byte received on the serial input port (sin) in UART mode or the serial infrared input (sir_in) in infrared mode. The data in this register is valid only if the Data Ready (DR) bit in the Line status Register (LSR) is set. If FIFOs are disabled (FCR[0] set to zero), the data in the RBR must be read before the next data arrives, otherwise it will be overwritten, resulting in an overrun error. If FIFOs are enabled (FCR[0] set to one), this register accesses the head of the receive FIFO. If the receive FIFO is full and this register is not read before the next data character arrives, then the data already in the FIFO will be preserved but any incoming data will be lost. An overrun error will also occur. Shadow Transmit Holding Register 0: This is a shadow register for the THR and has been allocated sixteen 32-bit locations so as to accommodate burst accesses from the master. This register contains data to be transmitted on the serial output port (sout) in UART mode or the serial infrared output (sir_out_n) in infrared mode. Data should only be written to the THR when the THR Empty (THRE) bit (LSR[5]) is set. If FIFO's are disabled (FCR[0] set to zero) and THRE is set, writing a single character to the THR clears the THRE. Any additional writes to the THR before the THRE is set again causes the THR data to be overwritten. If FIFO's are enabled (FCR[0] set to one) and THRE is set, x number of characters of data may be written to the THR before the FIFO is full. The number x (default=16) is determined by the value of FIFO Depth that you set during configuration. Any attempt to write	0x0

Bit	Mode	Symbol	Description	Reset
			data when the FIFO is full results in the write data being lost.	

Table 511: **UART3_SRBR_STHR7_REG (0x5002024C)**

Bit	Mode	Symbol	Description	Reset
31:8	-	-	Reserved	0x0
7:0	R/W	SRBR_STHRx	Shadow Receive Buffer Register x: This is a shadow register for the RBR and has been allocated sixteen 32-bit locations so as to accommodate burst accesses from the master. This register contains the data byte received on the serial input port (sin) in UART mode or the serial infrared input (sir_in) in infrared mode. The data in this register is valid only if the Data Ready (DR) bit in the Line status Register (LSR) is set. If FIFOs are disabled (FCR[0] set to zero), the data in the RBR must be read before the next data arrives, otherwise it will be overwritten, resulting in an overrun error. If FIFOs are enabled (FCR[0] set to one), this register accesses the head of the receive FIFO. If the receive FIFO is full and this register is not read before the next data character arrives, then the data already in the FIFO will be preserved but any incoming data will be lost. An overrun error will also occur. Shadow Transmit Holding Register 0: This is a shadow register for the THR and has been allocated sixteen 32-bit locations so as to accommodate burst accesses from the master. This register contains data to be transmitted on the serial output port (sout) in UART mode or the serial infrared output (sir_out_n) in infrared mode. Data should only be written to the THR when the THR Empty (THRE) bit (LSR[5]) is set. If FIFO's are disabled (FCR[0] set to zero) and THRE is set, writing a single character to the THR clears the THRE. Any additional writes to the THR before the THRE is set again causes the THR data to be overwritten. If FIFO's are enabled (FCR[0] set to one) and THRE is set, x number of characters of data may be written to the THR before the FIFO is full. The number x (default=16) is determined by the value of FIFO Depth that you set during configuration. Any attempt to write data when the FIFO is full results in the write data being lost.	0x0

Table 512: **UART3_SRBR_STHR8_REG (0x50020250)**

Bit	Mode	Symbol	Description	Reset
31:8	-	-	Reserved	0x0
7:0	R/W	SRBR_STHRx	Shadow Receive Buffer Register x: This is a shadow register for the RBR and has been allocated sixteen 32-bit locations so as to accommodate burst accesses from the master. This register contains the data byte received on the serial input port (sin) in UART mode or the serial infrared input (sir_in) in infrared mode. The data in this register is valid only if the Data Ready (DR) bit in the Line status Register (LSR) is set. If FIFOs are disabled (FCR[0] set to zero), the data in the RBR must be read before the next data arrives, otherwise it will be	0x0

Bit	Mode	Symbol	Description	Reset
			overwritten, resulting in an overrun error. If FIFOs are enabled (FCR[0] set to one), this register accesses the head of the receive FIFO. If the receive FIFO is full and this register is not read before the next data character arrives, then the data already in the FIFO will be preserved but any incoming data will be lost. An overrun error will also occur. Shadow Transmit Holding Register 0: This is a shadow register for the THR and has been allocated sixteen 32-bit locations so as to accommodate burst accesses from the master. This register contains data to be transmitted on the serial output port (sout) in UART mode or the serial infrared output (sir_out_n) in infrared mode. Data should only be written to the THR when the THR Empty (THRE) bit (LSR[5]) is set. If FIFO's are disabled (FCR[0] set to zero) and THRE is set, writing a single character to the THR clears the THRE. Any additional writes to the THR before the THRE is set again causes the THR data to be overwritten. If FIFO's are enabled (FCR[0] set to one) and THRE is set, x number of characters of data may be written to the THR before the FIFO is full. The number x (default=16) is determined by the value of FIFO Depth that you set during configuration. Any attempt to write data when the FIFO is full results in the write data being lost.	

Table 513: **UART3_SRBR_STHR9_REG (0x50020254)**

Bit	Mode	Symbol	Description	Reset
31:8	-	-	Reserved	0x0
7:0	R/W	SRBR_STHRx	Shadow Receive Buffer Register x: This is a shadow register for the RBR and has been allocated sixteen 32-bit locations so as to accommodate burst accesses from the master. This register contains the data byte received on the serial input port (sin) in UART mode or the serial infrared input (sir_in) in infrared mode. The data in this register is valid only if the Data Ready (DR) bit in the Line status Register (LSR) is set. If FIFOs are disabled (FCR[0] set to zero), the data in the RBR must be read before the next data arrives, otherwise it will be overwritten, resulting in an overrun error. If FIFOs are enabled (FCR[0] set to one), this register accesses the head of the receive FIFO. If the receive FIFO is full and this register is not read before the next data character arrives, then the data already in the FIFO will be preserved but any incoming data will be lost. An overrun error will also occur. Shadow Transmit Holding Register 0: This is a shadow register for the THR and has been allocated sixteen 32-bit locations so as to accommodate burst accesses from the master. This register contains data to be transmitted on the serial output port (sout) in UART mode or the serial infrared output (sir_out_n) in infrared mode. Data should only be written to the THR when the THR Empty (THRE) bit (LSR[5]) is set. If FIFO's are disabled (FCR[0] set to zero) and THRE is set, writing a single character to the THR clears the THRE. Any additional writes to the THR before the THRE is set again causes the THR data to be overwritten. If FIFO's are enabled (FCR[0] set to one)	0x0

Bit	Mode	Symbol	Description	Reset
			and THRE is set, x number of characters of data may be written to the THR before the FIFO is full. The number x (default=16) is determined by the value of FIFO Depth that you set during configuration. Any attempt to write data when the FIFO is full results in the write data being lost.	

Table 514: **UART3_SRBR_STHR10_REG (0x50020258)**

Bit	Mode	Symbol	Description	Reset
31:8	-	-	Reserved	0x0
7:0	R/W	SRBR_STHRx	Shadow Receive Buffer Register x: This is a shadow register for the RBR and has been allocated sixteen 32-bit locations so as to accommodate burst accesses from the master. This register contains the data byte received on the serial input port (sin) in UART mode or the serial infrared input (sir_in) in infrared mode. The data in this register is valid only if the Data Ready (DR) bit in the Line status Register (LSR) is set. If FIFOs are disabled (FCR[0] set to zero), the data in the RBR must be read before the next data arrives, otherwise it will be overwritten, resulting in an overrun error. If FIFOs are enabled (FCR[0] set to one), this register accesses the head of the receive FIFO. If the receive FIFO is full and this register is not read before the next data character arrives, then the data already in the FIFO will be preserved but any incoming data will be lost. An overrun error will also occur. Shadow Transmit Holding Register 0: This is a shadow register for the THR and has been allocated sixteen 32-bit locations so as to accommodate burst accesses from the master. This register contains data to be transmitted on the serial output port (sout) in UART mode or the serial infrared output (sir_out_n) in infrared mode. Data should only be written to the THR when the THR Empty (THRE) bit (LSR[5]) is set. If FIFO's are disabled (FCR[0] set to zero) and THRE is set, writing a single character to the THR clears the THRE. Any additional writes to the THR before the THRE is set again causes the THR data to be overwritten. If FIFO's are enabled (FCR[0] set to one) and THRE is set, x number of characters of data may be written to the THR before the FIFO is full. The number x (default=16) is determined by the value of FIFO Depth that you set during configuration. Any attempt to write data when the FIFO is full results in the write data being lost.	0x0

Table 515: **UART3_SRBR_STHR11_REG (0x5002025C)**

Bit	Mode	Symbol	Description	Reset
31:8	-	-	Reserved	0x0
7:0	R/W	SRBR_STHRx	Shadow Receive Buffer Register x: This is a shadow register for the RBR and has been allocated sixteen 32-bit locations so as to accommodate burst accesses from the master. This register contains the data byte received on the serial input port (sin) in UART mode or the serial infrared input (sir_in) in infrared mode. The data in this	0x0

Bit	Mode	Symbol	Description	Reset
			<p>register is valid only if the Data Ready (DR) bit in the Line status Register (LSR) is set. If FIFOs are disabled (FCR[0] set to zero), the data in the RBR must be read before the next data arrives, otherwise it will be overwritten, resulting in an overrun error. If FIFOs are enabled (FCR[0] set to one), this register accesses the head of the receive FIFO. If the receive FIFO is full and this register is not read before the next data character arrives, then the data already in the FIFO will be preserved but any incoming data will be lost. An overrun error will also occur. Shadow Transmit Holding Register 0: This is a shadow register for the THR and has been allocated sixteen 32-bit locations so as to accommodate burst accesses from the master. This register contains data to be transmitted on the serial output port (sout) in UART mode or the serial infrared output (sir_out_n) in infrared mode. Data should only be written to the THR when the THR Empty (THRE) bit (LSR[5]) is set. If FIFO's are disabled (FCR[0] set to zero) and THRE is set, writing a single character to the THR clears the THRE. Any additional writes to the THR before the THRE is set again causes the THR data to be overwritten. If FIFO's are enabled (FCR[0] set to one) and THRE is set, x number of characters of data may be written to the THR before the FIFO is full. The number x (default=16) is determined by the value of FIFO Depth that you set during configuration. Any attempt to write data when the FIFO is full results in the write data being lost.</p>	

Table 516: UART3_SRRB_STHR12_REG (0x50020260)

Bit	Mode	Symbol	Description	Reset
31:8	-	-	Reserved	0x0
7:0	R/W	SRBR_STHR _x	<p>Shadow Receive Buffer Register x: This is a shadow register for the RBR and has been allocated sixteen 32-bit locations so as to accommodate burst accesses from the master. This register contains the data byte received on the serial input port (sin) in UART mode or the serial infrared input (sir_in) in infrared mode. The data in this register is valid only if the Data Ready (DR) bit in the Line status Register (LSR) is set. If FIFOs are disabled (FCR[0] set to zero), the data in the RBR must be read before the next data arrives, otherwise it will be overwritten, resulting in an overrun error. If FIFOs are enabled (FCR[0] set to one), this register accesses the head of the receive FIFO. If the receive FIFO is full and this register is not read before the next data character arrives, then the data already in the FIFO will be preserved but any incoming data will be lost. An overrun error will also occur. Shadow Transmit Holding Register 0: This is a shadow register for the THR and has been allocated sixteen 32-bit locations so as to accommodate burst accesses from the master. This register contains data to be transmitted on the serial output port (sout) in UART mode or the serial infrared output (sir_out_n) in infrared mode. Data should only be written to the THR when the THR Empty (THRE) bit (LSR[5]) is set. If FIFO's are disabled (FCR[0] set to zero) and THRE is</p>	0x0

Bit	Mode	Symbol	Description	Reset
			set, writing a single character to the THR clears the THRE. Any additional writes to the THR before the THRE is set again causes the THR data to be overwritten. If FIFO's are enabled (FCR[0] set to one) and THRE is set, x number of characters of data may be written to the THR before the FIFO is full. The number x (default=16) is determined by the value of FIFO Depth that you set during configuration. Any attempt to write data when the FIFO is full results in the write data being lost.	

Table 517: **UART3_SRBR_STHR13_REG (0x50020264)**

Bit	Mode	Symbol	Description	Reset
31:8	-	-	Reserved	0x0
7:0	R/W	SRBR_STHRx	Shadow Receive Buffer Register x: This is a shadow register for the RBR and has been allocated sixteen 32-bit locations so as to accommodate burst accesses from the master. This register contains the data byte received on the serial input port (sin) in UART mode or the serial infrared input (sir_in) in infrared mode. The data in this register is valid only if the Data Ready (DR) bit in the Line status Register (LSR) is set. If FIFOs are disabled (FCR[0] set to zero), the data in the RBR must be read before the next data arrives, otherwise it will be overwritten, resulting in an overrun error. If FIFOs are enabled (FCR[0] set to one), this register accesses the head of the receive FIFO. If the receive FIFO is full and this register is not read before the next data character arrives, then the data already in the FIFO will be preserved but any incoming data will be lost. An overrun error will also occur. Shadow Transmit Holding Register 0: This is a shadow register for the THR and has been allocated sixteen 32-bit locations so as to accommodate burst accesses from the master. This register contains data to be transmitted on the serial output port (sout) in UART mode or the serial infrared output (sir_out_n) in infrared mode. Data should only be written to the THR when the THR Empty (THRE) bit (LSR[5]) is set. If FIFO's are disabled (FCR[0] set to zero) and THRE is set, writing a single character to the THR clears the THRE. Any additional writes to the THR before the THRE is set again causes the THR data to be overwritten. If FIFO's are enabled (FCR[0] set to one) and THRE is set, x number of characters of data may be written to the THR before the FIFO is full. The number x (default=16) is determined by the value of FIFO Depth that you set during configuration. Any attempt to write data when the FIFO is full results in the write data being lost.	0x0

Table 518: **UART3_SRBR_STHR14_REG (0x50020268)**

Bit	Mode	Symbol	Description	Reset
31:8	-	-	Reserved	0x0
7:0	R/W	SRBR_STHRx	Shadow Receive Buffer Register x: This is a shadow register for the RBR and has been allocated sixteen 32-	0x0

Bit	Mode	Symbol	Description	Reset
			<p>bit locations so as to accommodate burst accesses from the master. This register contains the data byte received on the serial input port (sin) in UART mode or the serial infrared input (sir_in) in infrared mode. The data in this register is valid only if the Data Ready (DR) bit in the Line status Register (LSR) is set. If FIFOs are disabled (FCR[0] set to zero), the data in the RBR must be read before the next data arrives, otherwise it will be overwritten, resulting in an overrun error. If FIFOs are enabled (FCR[0] set to one), this register accesses the head of the receive FIFO. If the receive FIFO is full and this register is not read before the next data character arrives, then the data already in the FIFO will be preserved but any incoming data will be lost. An overrun error will also occur. Shadow Transmit Holding Register 0: This is a shadow register for the THR and has been allocated sixteen 32-bit locations so as to accommodate burst accesses from the master. This register contains data to be transmitted on the serial output port (sout) in UART mode or the serial infrared output (sir_out_n) in infrared mode. Data should only be written to the THR when the THR Empty (THRE) bit (LSR[5]) is set. If FIFO's are disabled (FCR[0] set to zero) and THRE is set, writing a single character to the THR clears the THRE. Any additional writes to the THR before the THRE is set again causes the THR data to be overwritten. If FIFO's are enabled (FCR[0] set to one) and THRE is set, x number of characters of data may be written to the THR before the FIFO is full. The number x (default=16) is determined by the value of FIFO Depth that you set during configuration. Any attempt to write data when the FIFO is full results in the write data being lost.</p>	

Table 519: UART3_SRBR_STHR15_REG (0x5002026C)

Bit	Mode	Symbol	Description	Reset
31:8	-	-	Reserved	0x0
7:0	R/W	SRBR_STHRx	<p>Shadow Receive Buffer Register x: This is a shadow register for the RBR and has been allocated sixteen 32-bit locations so as to accommodate burst accesses from the master. This register contains the data byte received on the serial input port (sin) in UART mode or the serial infrared input (sir_in) in infrared mode. The data in this register is valid only if the Data Ready (DR) bit in the Line status Register (LSR) is set. If FIFOs are disabled (FCR[0] set to zero), the data in the RBR must be read before the next data arrives, otherwise it will be overwritten, resulting in an overrun error. If FIFOs are enabled (FCR[0] set to one), this register accesses the head of the receive FIFO. If the receive FIFO is full and this register is not read before the next data character arrives, then the data already in the FIFO will be preserved but any incoming data will be lost. An overrun error will also occur. Shadow Transmit Holding Register 0: This is a shadow register for the THR and has been allocated sixteen 32-bit locations so as to accommodate burst accesses from the master. This register contains data to be transmitted on the serial output port (sout) in</p>	0x0

Bit	Mode	Symbol	Description	Reset
			UART mode or the serial infrared output (sir_out_n) in infrared mode. Data should only be written to the THR when the THR Empty (THRE) bit (LSR[5]) is set. If FIFO's are disabled (FCR[0] set to zero) and THRE is set, writing a single character to the THR clears the THRE. Any additional writes to the THR before the THRE is set again causes the THR data to be overwritten. If FIFO's are enabled (FCR[0] set to one) and THRE is set, x number of characters of data may be written to the THR before the FIFO is full. The number x (default=16) is determined by the value of FIFO Depth that you set during configuration. Any attempt to write data when the FIFO is full results in the write data being lost.	

Table 520: **UART3_USR_REG (0x5002027C)**

Bit	Mode	Symbol	Description	Reset
31:5	-	-	Reserved	0x0
4	R	UART_RFF	Receive FIFO Full. This is used to indicate that the receive FIFO is completely full. 0 = Receive FIFO not full 1 = Receive FIFO Full This bit is cleared when the RX FIFO is no longer full.	0x0
3	R	UART_RFNE	Receive FIFO Not Empty. This is used to indicate that the receive FIFO contains one or more entries. 0 = Receive FIFO is empty 1 = Receive FIFO is not empty This bit is cleared when the RX FIFO is empty.	0x0
2	R	UART_TFE	Transmit FIFO Empty. This is used to indicate that the transmit FIFO is completely empty. 0 = Transmit FIFO is not empty 1 = Transmit FIFO is empty This bit is cleared when the TX FIFO is no longer empty.	0x1
1	R	UART_TFNF	Transmit FIFO Not Full. This is used to indicate that the transmit FIFO is not full. 0 = Transmit FIFO is full 1 = Transmit FIFO is not full This bit is cleared when the TX FIFO is full.	0x1
0	R	UART_BUSY	UART Busy. This indicates that a serial transfer is in progress, when cleared indicates that the DW_apb_uart is idle or inactive. 0 - DW_apb_uart is idle or inactive 1 - DW_apb_uart is busy (actively transferring data) Note that it is possible for the UART Busy bit to be cleared even though a new character may have been sent from another device. That is, if the DW_apb_uart has no data in the THR and RBR and there is no transmission in progress and a start bit of a new character has just reached the DW_apb_uart. This is due to the fact that a valid start is not seen until the middle of the bit period	0x0

Bit	Mode	Symbol	Description	Reset
			and this duration is dependent on the baud divisor that has been programmed. If a second system clock has been implemented (CLOCK_MODE == Enabled) the assertion of this bit will also be delayed by several cycles of the slower clock.	

Table 521: **UART3_TFL_REG** (0x50020280)

Bit	Mode	Symbol	Description	Reset
4:0	R	UART_TRANSMIT_FIFO_LEVEL	Transmit FIFO Level. This indicates the number of data entries in the transmit FIFO.	0x0

Table 522: **UART3_RFL_REG** (0x50020284)

Bit	Mode	Symbol	Description	Reset
4:0	R	UART_RECEIVE_FIFO_LEVEL	Receive FIFO Level. This indicates the number of data entries in the receive FIFO.	0x0

Table 523: **UART3_SRR_REG** (0x50020288)

Bit	Mode	Symbol	Description	Reset
31:3	-	-	Reserved	0x0
2	W	UART_XFR	XMIT FIFO Reset. This is a shadow register for the XMIT FIFO Reset bit (FCR[2]). This can be used to remove the burden on software having to store previously written FCR values (which are pretty static) just to reset the transmit FIFO. This resets the control portion of the transmit FIFO and treats the FIFO as empty. Note that this bit is 'self-clearing'. It is not necessary to clear this bit.	0x0
1	W	UART_RFR	RCVR FIFO Reset. This is a shadow register for the RCVR FIFO Reset bit (FCR[1]). This can be used to remove the burden on software having to store previously written FCR values (which are pretty static) just to reset the receive FIFO. This resets the control portion of the receive FIFO and treats the FIFO as empty. Note that this bit is 'self-clearing'. It is not necessary to clear this bit.	0x0
0	W	UART_UR	UART Reset. This asynchronously resets the UART Ctrl and synchronously removes the reset assertion. For a two clock implementation both pclk and sclk domains are reset.	0x0

Table 524: **UART3_SRTS_REG** (0x5002028C)

Bit	Mode	Symbol	Description	Reset
31:1	-	-	Reserved	0x0

Bit	Mode	Symbol	Description	Reset
0	R/W	UART_SHADOW_REQUEST_TO_SEND	<p>Shadow Request to Send.</p> <p>This is a shadow register for the RTS bit (MCR[1]), this can be used to remove the burden of having to performing a read-modify-write on the MCR. This is used to directly control the Request to Send (rts_n) output. The Request To Send (rts_n) output is used to inform the modem or data set that the UART Ctrl is ready to exchange data.</p> <p>When Auto RTS Flow Control is not enabled (MCR[5] = 0), the rts_n signal is set low by programming MCR[1] (RTS) to a high.</p> <p>In Auto Flow Control, (active MCR[5] = 1) and FIFOs enable (FCR[0] = 1), the rts_n output is controlled in the same way, but is also gated with the receiver FIFO threshold trigger (rts_n is inactive high when above the threshold).</p> <p>Note that in Loopback mode (MCR[4] = 1), the rts_n output is held inactive-high while the value of this location is internally looped back to an input.</p>	0x0

Table 525: **UART3_SBCR_REG** (0x50020290)

Bit	Mode	Symbol	Description	Reset
31:1	-	-	Reserved	0x0
0	R/W	UART_SHADOW_BREAK_CONTROL	<p>Shadow Break Control Bit.</p> <p>This is a shadow register for the Break bit (LCR[6]), this can be used to remove the burden of having to performing a read modify write on the LCR. This is used to cause a break condition to be transmitted to the receiving device.</p> <p>If set to one the serial output is forced to the spacing (logic 0) state. When not in Loopback Mode, as determined by MCR[4], the sout line is forced low until the Break bit is cleared.</p>	0x0

Table 526: **UART3_SDMAM_REG** (0x50020294)

Bit	Mode	Symbol	Description	Reset
31:1	-	-	Reserved	0x0
0	R/W	UART_SHADOW_DMA_MODE	<p>Shadow DMA Mode.</p> <p>This is a shadow register for the DMA mode bit (FCR[3]). This can be used to remove the burden of having to store the previously written value to the FCR in memory and having to mask this value so that only the DMA Mode bit gets updated. This determines the DMA signalling mode used for the dma_tx_req_n and dma_rx_req_n output signals.</p> <p>0 = mode 0 1 = mode 1</p>	0x0

Table 527: **UART3_SFE_REG** (0x50020298)

Bit	Mode	Symbol	Description	Reset
31:1	-	-	Reserved	0x0
0	R/W	UART_SHADOW_FIFO_ENABLE	Shadow FIFO Enable. This is a shadow register for the FIFO enable bit (FCR[0]). This can be used to remove the burden of having to store the previously written value to the FCR in memory and having to mask this value so that only the FIFO enable bit gets updated. This enables/disables the transmit (XMIT) and receive (RCVR) FIFOs. If this bit is set to zero (disabled) after being enabled then both the XMIT and RCVR controller portion of FIFOs are reset.	0x0

Table 528: **UART3_SRT_REG** (0x5002029C)

Bit	Mode	Symbol	Description	Reset
31:2	-	-	Reserved	0x0
1:0	R/W	UART_SHADOW_RCVR_TRIGGER	Shadow RCVR Trigger. This is a shadow register for the RCVR trigger bits (FCR[7:6]). This can be used to remove the burden of having to store the previously written value to the FCR in memory and having to mask this value so that only the RCVR trigger bit gets updated. This is used to select the trigger level in the receiver FIFO at which the Received Data Available Interrupt is generated. It also determines when the dma_rx_req_n signal is asserted when DMA Mode (FCR[3]) = 1. The following trigger levels are supported: 00 = 1 character in the FIFO 01 = FIFO ¼ full 10 = FIFO ½ full 11 = FIFO 2 less than full	0x0

Table 529: **UART3_STET_REG** (0x500202A0)

Bit	Mode	Symbol	Description	Reset
31:2	-	-	Reserved	0x0
1:0	R/W	UART_SHADOW_TX_EMPTY_TRIGGER	Shadow TX Empty Trigger. This is a shadow register for the TX empty trigger bits (FCR[5:4]). This can be used to remove the burden of having to store the previously written value to the FCR in memory and having to mask this value so that only the TX empty trigger bit gets updated. This is used to select the empty threshold level at which the THRE Interrupts are generated when the mode is active. The following trigger levels are supported: 00 = FIFO empty 01 = 2 characters in the FIFO 10 = FIFO ¼ full 11 = FIFO ½ full	0x0

Table 530: **UART3_HTX_REG** (0x500202A4)

Bit	Mode	Symbol	Description	Reset
31:1	-	-	Reserved	0x0
0	R/W	UART_HALT_TX	This register is use to halt transmissions, so that the transmit FIFO can be filled by the master when FIFOs are implemented and enabled. 0 = Halt TX disabled 1 = Halt TX enabled Note, if FIFOs are not enabled, the setting of the halt TX register has no effect on operation.	0x0

Table 531: **UART3_DMASA_REG** (0x500202A8)

Bit	Mode	Symbol	Description	Reset
31:1	-	-	Reserved	0x0
0	W	UART_DMASA	This register is use to perform DMA software acknowledge if a transfer needs to be terminated due to an error condition. For example, if the DMA disables the channel, then the DW_apb_uart should clear its request. This will cause the TX request, TX single, RX request and RX single signals to de-assert. Note that this bit is 'self-clearing' and it is not necessary to clear this bit.	0x0

Table 532: **UART3_DLF_REG** (0x500202C0)

Bit	Mode	Symbol	Description	Reset
31:4	-	-	Reserved	0x0
3:0	R/W	UART_DLF	The fractional value is added to integer value set by DLH, DLL. Fractional value is equal UART_DLF/16	0x0

Table 533: **UART3_RAR_REG** (0x500202C4)

Bit	Mode	Symbol	Description	Reset
7:0	R/W	UART_RAR	This is an address matching register during receive mode. If the 9-th bit is set in the incoming character then the remaining 8-bits will be checked against this register value. If the match happens then sub-sequent characters with 9-th bit set to 0 will be treated as data byte until the next address byte is received. Note: - This register is applicable only when 'ADDR_MATCH'(LCR_EXT[1] and 'DLS_E' (LCR_EXT[0]) bits are set to 1. RAR should be programmed only when UART is not busy.	0x0

Table 534: **UART3_TAR_REG** (0x500202C8)

Bit	Mode	Symbol	Description	Reset
7:0	R/W	UART_TAR	This is an address matching register during transmit mode. If DLS_E (LCR_EXT[0]) bit is enabled, then uart	0x0

Bit	Mode	Symbol	Description	Reset
			<p>will send the 9-bit character with 9-th bit set to 1 and remaining 8-bit address will be sent from this register provided 'SEND_ADDR' (LCR_EXT[2]) bit is set to 1.</p> <p>Note:</p> <ul style="list-style-type: none"> - This register is used only to send the address. The normal data should be sent by programming THR register. - Once the address is started to send on the DW_apb_uart serial lane, then 'SEND_ADDR' bit will be auto-cleared by the hardware. 	

Table 535: **UART3_LCR_EXT (0x500202CC)**

Bit	Mode	Symbol	Description	Reset
3	R/W	UART_TRANSMIT_MODE	<p>Transmit mode control bit. This bit is used to control the type of transmit mode during 9-bit data transfers.</p> <p>1 = In this mode of operation, Transmit Holding Register (THR) and Shadow Transmit Holding Register (STHR) are 9-bit wide. The user needs to ensure that the THR/STHR register is written correctly for address/data.</p> <p>Address: 9th bit is set to 1, Data : 9th bit is set to 0.</p> <p>Note: Transmit address register (TAR) is not applicable in this mode of operation.</p> <p>0 = In this mode of operation, Transmit Holding Register (THR) and Shadow Transmit Holding register (STHR) are 8-bit wide. The user needs to program the address into Transmit Address Register (TAR) and data into the THR/STHR register. SEND_ADDR bit is used as a control knob to indicate the uart on when to send the address.</p>	0x0
2	R/W	UART_SEND_ADDR	<p>Send address control bit. This bit is used as a control knob for the user to determine when to send the address during transmit mode.</p> <p>1 = 9-bit character will be transmitted with 9-th bit set to 1 and the remaining 8-bits will match to what is being programmed in 'Transmit Address Register'.</p> <p>0 = 9-bit character will be transmitted with 9-th bit set to 0 and the remaining 8-bits will be taken from the TXFIFO which is programmed through 8-bit wide THR/STHR register.</p> <p>Note:</p> <ol style="list-style-type: none"> 1. This bit is auto-cleared by the hardware, after sending out the address character. User is not expected to program this bit to 0. 2. This field is applicable only when DLS_E bit is set to 1 and TRANSMIT_MODE is set to 0. 	0x0
1	R/W	UART_ADDR_MATCH	<p>Address Match Mode. This bit is used to enable the address match feature during receive.</p> <p>1 = Address match mode; uart will wait until the incoming character with 9-th bit set to 1. And further checks to see if the address matches with what is programmed in 'Receive Address Match Register'. If match is found, then sub-sequent characters will be</p>	0x0

Bit	Mode	Symbol	Description	Reset
			treated as valid data and DW_apb_uart starts receiving data. 0 = Normal mode; DW_apb_uart will start to receive the data and 9-bit character will be formed and written into the receive RXFIFO. User is responsible to read the data and differentiate b/n address and data. Note: This field is applicable only when DLS_E is set to 1.	
0	R/W	UART_DLS_E	Extension for DLS. This bit is used to enable 9-bit data for transmit and receive transfers.	0x0

Table 536: **UART3_CTRL_REG (0x500202E0)**

Bit	Mode	Symbol	Description	Reset
31:12	-	-	Reserved	0x0
11	R/W	ISO7816_AUTO_GT	0 : uart sends when tx data is available 1 : uart sends new character after guard time	0x0
10	R/W	ISO7816_ERR_TX_VALUE_IRQMASK	0 : ERR_TX_VALUE IRQ is masked 1 : ERR_TX_VALUE IRQ is enabled	0x0
9	R/W	ISO7816_ERR_TX_TIME_IRQMASK	0 : ERR_TX_TIME IRQ is masked 1 : ERR_TX_TIME IRQ is enabled	0x0
8	R/W	ISO7816_TIM_EXPIRED_IRQMASK	0 : timer expired IRQ is masked 1 : timer expired IRQ is enabled	0x0
7	R	ISO7816_CLK_STATUS	0 : iso7816 clock is stopped 1 : iso7816 clock is running	0x0
6	R/W	ISO7816_CLK_LEVEL	0 : iso7816 clock level low when stopped 1 : iso7816 clock level high when stopped	0x0
5	R/W	ISO7816_CLK_EN	0 : iso7816 clock disabled 1 : iso7816 clock enabled	0x0
4:0	R/W	ISO7816_CLK_DIV	ISO7816 clk freq = sclk/(2*(ISO7816_CLK_DIV+1))	0x0

Table 537: **UART3_TIMER_REG (0x500202E4)**

Bit	Mode	Symbol	Description	Reset
31:18	-	-	Reserved	0x0
17	R/W	ISO7816_TIM_MODE	0 : Timer will count up to max value then stops. Timer has to be disabled and enabled again to restart. Timer is clocked with the ISO7816 clock 1 : Timer will count guard time. ISO7816_TIM_MAX has to be 16*GuardTime-1	0x0

Bit	Mode	Symbol	Description	Reset
16	R/W	ISO7816_TIM_EN	0 : Timer is disabled 1 : Timer is enabled	0x0
15:0	R/W	ISO7816_TIM_MAX	On write : timer will count from 0 to ISO7816_TIM_MAX On read : gives the current timer value	0x0

Table 538: **UART3_ERR_CTRL_REG (0x500202E8)**

Bit	Mode	Symbol	Description	Reset
31:9	-	-	Reserved	0x0
8:4	R/W	ISO7816_ERR_PULSE_WIDTH	When Error Signal feature is enable and receive mode, it gives the width of the error signal in 1/16etu	0x10
3:0	R/W	ISO7816_ERR_PULSE_OFFSET	When Error Signal feature is enable and receive mode, it gives the offset of the error signal in 1/16etu from the 9.6etu	0xE

Table 539: **UART3_IRQ_STATUS_REG (0x500202EC)**

Bit	Mode	Symbol	Description	Reset
31:3	-	-	Reserved	0x0
2	R/W	ISO7816_ERR_TX_VALUE_IRQ	On read 1 : : If error signal is enabled and in transmit mode, module generates IRQ when receiver does not receive correctly the character On Write 1 : Clear IRQ	0x0
1	R/W	ISO7816_ERR_TX_TIME_IRQ	On read 1 : If error signal is enabled and in transmit mode, module generates IRQ when it checks the error signal On Write 1 : Clear IRQ	0x0
0	R	ISO7816_TIM_EXPIRED_IRQ	On read 1 : when Timer is expired. Timer has to be disabled to clear the IRQ. When sclk is lower than pclk then this bit has to be checked if it's cleared before return form the IRQ Handler	0x0

Table 540: **UART3_UCV_REG (0x500202F8)**

Bit	Mode	Symbol	Description	Reset
31:0	R	UART_UCV	Component Version	0x3430312A

Table 541: **UART3_CTR_REG** (0x500202FC)

Bit	Mode	Symbol	Description	Reset
31:0	R	UART_CTR	Component Type Register	0x445701 10

42.17 USB Controller Registers

Table 542: Register map USB

Address	Register	Description
0x50040000	USB_MCTRL_REG	Main Control Register)
0x50040004	USB_XCVDIAG_REG	Transceiver diagnostic Register (for test purpose only)
0x50040008	USB_TCR_REG	Transceiver configuration Register
0x5004000C	USB_UTR_REG	USB test Register (for test purpose only)
0x50040010	USB_FAR_REG	Function Address Register
0x50040014	USB_NFSR_REG	Node Functional State Register
0x50040018	USB_MAEV_REG	Main Event Register
0x5004001C	USB_MAMSK_REG	Main Mask Register
0x50040020	USB_ALTEV_REG	Alternate Event Register
0x50040024	USB_ALTMSK_REG	Alternate Mask Register
0x50040028	USB_TXEV_REG	Transmit Event Register
0x5004002C	USB_TXMSK_REG	Transmit Mask Register
0x50040030	USB_RXEV_REG	Receive Event Register
0x50040034	USB_RXMSK_REG	Receive Mask Register
0x50040038	USB_NAKEV_REG	NAK Event Register
0x5004003C	USB_NAKMSK_REG	NAK Mask Register
0x50040040	USB_FWEV_REG	FIFO Warning Event Register
0x50040044	USB_FWMSK_REG	FIFO Warning Mask Register
0x50040048	USB_FNH_REG	Frame Number High Byte Register
0x5004004C	USB_FNL_REG	Frame Number Low Byte Register
0x5004007C	USB_UX20CDR_REG	Transceiver 2.0 Configuration and Diagnostics Register(for test purpose only)
0x50040080	USB_EPC0_REG	Endpoint Control 0 Register
0x50040084	USB_TXD0_REG	Transmit Data 0 Register
0x50040088	USB_TXS0_REG	Transmit Status 0 Register
0x5004008C	USB_TXC0_REG	Transmit command 0 Register
0x50040090	USB_EP0_NAK_REG	EP0 INNAK and OUTNAK Register
0x50040094	USB_RXD0_REG	Receive Data 0 Register
0x50040098	USB_RXS0_REG	Receive Status 0 Register
0x5004009C	USB_RXC0_REG	Receive Command 0 Register
0x500400A0	USB_EPC1_REG	Endpoint Control Register 1
0x500400A4	USB_TXD1_REG	Transmit Data Register 1

Address	Register	Description
0x500400A8	USB_TXS1_REG	Transmit Status Register 1
0x500400AC	USB_TXC1_REG	Transmit Command Register 1
0x500400B0	USB_EPC2_REG	Endpoint Control Register 2
0x500400B4	USB_RXD1_REG	Receive Data Register,1
0x500400B8	USB_RXS1_REG	Receive Status Register 1
0x500400BC	USB_RXC1_REG	Receive Command Register 1
0x500400C0	USB_EPC3_REG	Endpoint Control Register 3
0x500400C4	USB_TXD2_REG	Transmit Data Register 2
0x500400C8	USB_TXS2_REG	Transmit Status Register 2
0x500400CC	USB_TXC2_REG	Transmit Command Register 2
0x500400D0	USB_EPC4_REG	Endpoint Control Register 4
0x500400D4	USB_RXD2_REG	Receive Data Register 2
0x500400D8	USB_RXS2_REG	Receive Status Register 2
0x500400DC	USB_RXC2_REG	Receive Command Register 2
0x500400E0	USB_EPC5_REG	Endpoint Control Register 5
0x500400E4	USB_TXD3_REG	Transmit Data Register 3
0x500400E8	USB_TXS3_REG	Transmit Status Register 3
0x500400EC	USB_TXC3_REG	Transmit Command Register 3
0x500400F0	USB_EPC6_REG	Endpoint Control Register 6
0x500400F4	USB_RXD3_REG	Receive Data Register 3
0x500400F8	USB_RXS3_REG	Receive Status Register 3
0x500400FC	USB_RXC3_REG	Receive Command Register 3
0x500401A0	USB_DMA_CTRL_REG	USB DMA control register
0x500401A8	USB_CHARGER_CTRL_REG	USB Charger Control Register
0x500401AC	USB_CHARGER_STAT_REG	USB Charger Status Register

Table 543: USB_MCTRL_REG (0x50040000)

Bit	Mode	Symbol	Description	Reset
31:15	-	-	Reserved	0x0
4	R/W	LSMODE	Low Speed Mode This bit enables USB 1.5 Mbit/s low speed and swaps D+ and D- pull-up resistors. Changing speed may only be done if USBEN is set to 0. Also D+ and D- rise and fall times are adjusted according to the USB specification.	0x0
3	R/W	USB_NAT	Node Attached This bit indicates that this node is ready to be detected as attached to USB. When cleared to 0 the transceiver forces SE0 on the USB port to prevent the hub (to which this node is connected to) from detecting an attach event. After reset or when the USB node is disabled, this bit is cleared to 0 to give the device time before it must	0x0

Bit	Mode	Symbol	Description	Reset
			respond to commands. After this bit has been set to 1, the device no longer drives the USB and should be ready to receive Reset signalling from the hub. Note: This bit can only be set is USBEN is '1'	
2	-	-	Reserved	0x0
1	R/W	USB_DBG	Debug Mode. When this bit is set, the following registers are writable: Main Event (MAEV), Alternate Event (ALTEV), NAK Event (NAKEV), Transmit Status and Receive Status. Setting the DBG bit forces the node into a locked state. The node states can be read out of the transceiver diagnostic register (XCVDIAG) at location 0xFF6802 by setting the DIAG bit in the Test Control register (UTR). Note: The operation of CoR bits is not effected by entering Debug mode) Note: This bit can only be set is USBEN is '1'	0x0
0	R/W	USBEN	USB EnableSetting this bit to 1 enables the Full/Low Speed USB node. If the USBEN bit is cleared to 0, the USB is disabled and the 48 MHz clock within the USB node is stopped. In addition, all USB registers are set to their reset state. Note that the transceiver forces SE0 on the bus to prevent the hub to detected the USB node, when it is disabled (not attached). The USBEN bit is cleared to 0 after reset	0x0

Table 544: **USB_XCVDIAG_REG (0x50040004)**

Bit	Mode	Symbol	Description	Reset
31:8	-	-	Reserved	0x0
7	R	USB_VPIN	With Bit0 = 1 this bit shows the level of the USB_Dp receive data from transceiver; i.e. D+ <= VSE.	0x0
6	R	USB_VMIN	With Bit0 = 1 this bit shows the level USB_Dm receive data from transceiver; i.e. D- <= VSE.	0x0
5	R	USB_RCV	With Bit0 = 1 this bit shows the differential level of the receive comparator.	0x0
4	-	-	Reserved	0x0
3	R/W	USB_XCV_TXEN	With Bit0 = 1, this bit enables test Bits 2,1. Must be kept to '0' for normal operation	0x0
2	R/W	USB_XCV_TXn	With Bit3,0 = 1, this bit sets USB_Dm to a high level, independent of LSMODE selection	0x0
1	R/W	USB_XCV_TXp	With Bit3,0 = 1, this bit sets USB_Dp to a high level, independent of LSMODE selection	0x0
0	R/W	USB_XCV_TEST	Enable USB_XCVDIAG_REG 0: Normal operation, test bits disabled 1: Enable test bits 7,6,5,3,2,1	0x0

Table 545: **USB_TCR_REG (0x50040008)**

Bit	Mode	Symbol	Description	Reset
31:8	-	-	Reserved	0x0
7:5	R/W	USB_VADJ	Reference Voltage/ Threshold voltage Adjust Controls the single-ended receiver threshold. Shall not be modified unless instructed by Dialog Semiconductor Only enabled if USB_UTR_REG[7] = 1	0x4
4:0	R/W	USB_CADJ	Transmitter Current Adjust Controls the driver edge rate control current. Shall not be modified unless instructed by Dialog Semiconductor Only enabled if USB_UTR_REG[7] = 1	0x10

Table 546: **USB_UTR_REG (0x5004000C)**

Bit	Mode	Symbol	Description	Reset
31:8	-	-	Reserved	0x0
7	R/W	USB_DIAG	Diagnostic enable '0': Normal operational. '1': Access to the USB_XCVDIAG_REG and USB_TCR_REG enabled. For diagnostic purposes only	0x0
6	R/W	USB_NCRC	No CRC16 When this bit is set to 1, all packets transmitted by the Full/Low Speed USB node are sent without a trailing CRC16. Receive operations are unaffected. This mode is used to check that CRC errors can be detected by other nodes. For diagnostic purposes only	0x0
5	R/W	USB_SF	Short Frame Enables the Frame timer to lock and track, short, non-compliant USB frame sizes. The Short Frame bit should not be set during normal operation. For test purposes only	0x0
4:0	R/W	USB_UTR_RES	Reserved. Must be kept to '0'	0x0

Table 547: **USB_FAR_REG (0x50040010)**

Bit	Mode	Symbol	Description	Reset
31:8	-	-	Reserved	0x0
7	R/W	USB_AD_EN	Address Enable When set to 1, USB address field bits 6-0 are used in address comparison When cleared to 0, the device does not respond to any token on the USB bus. Note: If the DEF bit in the Endpoint Control 0 register is set, Endpoint 0 responds to the default address.	0x0
6:0	R/W	USB_AD	Address This field holds the 7-bit function address used to transmit and receive all tokens addressed to this device.	0x0

Table 548: **USB_NFSR_REG** (0x50040014)

Bit	Mode	Symbol	Description	Reset
31:2	-	-	Reserved	0x0
1:0	R/W	USB_NFS	<p>The Node Functional State Register reports and controls the current functional state of the USB node.</p> <p>00: NodeReset. This is the USB Reset state. This is entered upon a module reset or by software upon detection of a USB Reset. Upon entry, all endpoint pipes are disabled. DEF in the Endpoint Control 0 (EPC0) register and AD_EN in the Function Address (FAR) register should be cleared by software on entry to this state. On exit, DEF should be reset so the device responds to the default address.</p> <p>01: NodeResume In this state, resume signalling is generated. This state should be entered by firmware to initiate a remote wake-up sequence by the device. The node must remain in this state for at least 1 ms and no more than 15 ms.</p> <p>10: NodeOperational This is the normal operational state. In this state the node is configured for operation on the USB bus.</p> <p>11: NodeSuspend Suspend state should be entered by firmware on detection of a Suspend event while in Operational state. While in Suspend state, the transceivers operate in their low-power suspend mode. All endpoint controllers and the bits TX_EN, LAST and RX_EN are reset, while all other internal states are frozen. On detection of bus activity, the RESUME bit in the ALTEV register is set. In response, software can cause entry to NodeOperational state.</p>	0x0

Table 549: **USB_MAEV_REG** (0x50040018)

Bit	Mode	Symbol	Description	Reset
31:12	-	-	Reserved	0x0
11	R/W	USB_CH_EV	<p>USB Charger event</p> <p>This bit is set if one of the bits in USB_CHARGER_STAT_REG[2-0] change. This bit is cleared to 0 when if USB_CHARGER_STAT_REG is read.</p>	0x0
10	R/W	USB_EP0_NAK	<p>Endpoint 0 NAK Event</p> <p>This bit is an OR of EP0_NAK_REG[EP0_OUTNAK] and EP0_NAK_REG[EP0_INNAK] bits. USB_EP0_NAK is cleared to 0 when EP0_NAK_REG is read.</p>	0x0
9	R/W	USB_EP0_RX	<p>Endpoint 0 Receive Event</p> <p>This bit is a copy of the RXS0[RX_LAST] and is cleared to 0 when this RXS0 register is read.</p> <p>Note: Since Endpoint 0 implements a store and forward principle, an overrun condition for FIFO0 cannot occur</p>	0x0
8	R/W	USB_EP0_TX	<p>Endpoint 0 Transmit Event</p> <p>This bit is a copy of the TXS0[TX_DONE] bit and is cleared to 0 when the TXS0 register is read.</p>	0x0

Bit	Mode	Symbol	Description	Reset
			Note: Since Endpoint 0 implements a store and forward principle, an underrun condition for FIFO0 cannot occur.	
7	R/W	USB_INTR	Master Interrupt Enable This bit is hardwired to 0 in the Main Event (MAEV) register; bit 7 in the Main Mask (MAMSK) register is the Master Interrupt Enable.	0x0
6	R/W	USB_RX_EV	Receive Event This bit is set to 1 if any of the unmasked bits in the Receive Event (RXEV) register is set to 1. It indicates that a SETUP or OUT transaction has been completed. This bit is cleared to 0 when all of the RX_LAST bits in each Receive Status (RXSn) register and all RXOVRN bits in the RXEV register are cleared to 0.	0x0
5	R/W	USB_ULD	Unlocked/Locked Detected This bit is set to 1, when the frame timer has either entered unlocked condition from a locked condition, or has re-entered a locked condition from an unlocked condition as determined by the UL bit in the Frame Number (FNH or FNL) register. This bit is cleared to 0 when the register is read.	0x0
4	R/W	USB_NAK	Negative Acknowledge Event This bit indicates that one of the unmasked NAK Event (NAKEV) register bits has been set to 1. This bit is cleared to 0 when the NAKEV register is read.	0x0
3	R/W	USB_FRAME	Frame Event This bit is set to 1, if the frame counter is updated with a new value. This can be due to the receipt of a valid SOF packet on the USB or to an artificial update if the frame counter was unlocked or a frame was missed. This bit is cleared to 0 when the register is read.	0x0
2	R/W	USB_TX_EV	Transmit Event This bit is set to 1, if any of the unmasked bits in the Transmit Event (TXEV) register (TXFIFO _n or TXUNDRN _n) is set to 1. Therefore, it indicates that an IN transaction has been completed. This bit is cleared to 0 when all the TX_DONE bits and the TXUNDRN bits in each Transmit Status (TXSn) register are cleared to 0.	0x0
1	R/W	USB_ALT	Alternate Event This bit indicates that one of the unmasked ALTEV register bits has been set to 1. This bit is cleared to 0 by reading the ALTEV register.	0x0
0	R/W	USB_WARN	Warning Event This bit indicates that one of the unmasked bits in the FIFO Warning Event (FWEV) register has been set to 1. This bit is cleared to 0 by reading the FWEV register.	0x0

Table 550: USB_MAMSK_REG (0x5004001C)

Bit	Mode	Symbol	Description	Reset
31:12	-	-	Reserved	0x0
11	R/W	USB_M_CH_EV	The Main Mask Register masks out events reported in the MAEV registers. A bit set to 1, enables the interrupts for the respective event in the MAEV register. If the	0x0

Bit	Mode	Symbol	Description	Reset
			corresponding bit is cleared to 0, interrupt generation for this event is disabled. Same Bit Definition as MAEV Register	
10	R/W	USB_M_EP0_NAK	Same Bit Definition as MAEV Register	0x0
9	R/W	USB_M_EP0_RX	Same Bit Definition as MAEV Register	0x0
8	R/W	USB_M_EP0_TX	Same Bit Definition as MAEV Register	0x0
7	R/W	USB_M_INTR	Same Bit Definition as MAEV Register	0x0
6	R/W	USB_M_RX_EV	Same Bit Definition as MAEV Register	0x0
5	R/W	USB_M_ULD	Same Bit Definition as MAEV Register	0x0
4	R/W	USB_M_NAK	Same Bit Definition as MAEV Register	0x0
3	R/W	USB_M_FRAME	Same Bit Definition as MAEV Register	0x0
2	R/W	USB_M_TX_EV	Same Bit Definition as MAEV Register	0x0
1	R/W	USB_M_ALT	Same Bit Definition as MAEV Register	0x0
0	R/W	USB_M_WARN	Same Bit Definition as MAEV Register	0x0

Table 551: **USB_ALTEV_REG (0x50040020)**

Bit	Mode	Symbol	Description	Reset
31:8	-	-	Reserved	0x0
7	R/W	USB_RESUME	Resume Resume signalling is detected on the USB when the device is in Suspend state (NFS in the NFSR register is set to SUSPEND), and a non IDLE signal is present on the USB, indicating that this device should begin its wake-up sequence and enter Operational state. This bit is cleared when the register is read.	0x0
6	R/W	USB_RESET	Reset This bit is set to 1, when 2.5 us of SEO have been detected on the upstream port. In response, the functional state should be reset (NFS in the NFSR register is set to RESET), where it must remain for at least 100 us. The functional state can then return to Operational state. This bit is cleared when the register is read	0x0
5	R/W	USB_SD5	Suspend Detect 5 ms This bit is set to 1 after 5 ms of IDLE have been detected on the upstream port, indicating that this device is permitted to perform a remote wake-up operation. The resume may be initiated under firmware control by writing the resume value to the NFSR register. This bit is cleared when the register is read.	0x0
4	R/W	USB_SD3	Suspend Detect 3 ms This bit is set to 1 after 3 ms of IDLE have been detected on the upstream port, indicating that the device should be suspended. The suspend occurs under firmware control by writing the suspend value to the Node Functional State (NFSR) register. This bit is cleared when the register is read.	0x0
3	R/W	USB_EOP	End of Packet	0x0

Bit	Mode	Symbol	Description	Reset
			A valid EOP sequence was been detected on the USB. It is used when this device has initiated a Remote wake-up sequence to indicate that the Resume sequence has been acknowledged and completed by the host. This bit is cleared when the register is read.	
2	-	-	Reserved	0x0
1:0	-	-	Reserved	0x0

Table 552: **USB_ALTMSK_REG** (0x50040024)

Bit	Mode	Symbol	Description	Reset
31:8	-	-	Reserved	0x0
7	R/W	USB_M_RESUME	A bit set to 1 in this register enables automatic setting of the ALT bit in the MAEV register when the respective event in the ALTEV register occurs. Otherwise, setting MAEV.ALT bit is disabled. Same Bit Definition as ALTEV Register	0x0
6	R/W	USB_M_RESET	Same Bit Definition as ALTEV Register	0x0
5	R/W	USB_M_SD5	Same Bit Definition as ALTEV Register	0x0
4	R/W	USB_M_SD3	Same Bit Definition as ALTEV Register	0x0
3	R/W	USB_M_EOP	Same Bit Definition as ALTEV Register	0x0
2	-	-	Reserved	0x0
1:0	-	-	Reserved	0x0

Table 553: **USB_TXEV_REG** (0x50040028)

Bit	Mode	Symbol	Description	Reset
31:7	-	-	Reserved	0x0
6:4	R	USB_TXUDRRN31	Transmit Underrun n: 3:1 The bit n is a copy of the respective TX_URUN bit from the corresponding Transmit Status register (TXSn). Whenever any of the Transmit FIFOs underflows, the respective TXUDRRN bit is set to 1. These bits are cleared to 0 when the corresponding Transmit Status register is read	0x0
3	-	-	Reserved	0x0
2:0	R	USB_TXFIFO31	Transmit FIFO n: 3:1 The bit n is a copy of the TX_DONE bit from the corresponding Transmit Status register (TXSn). A bit is set to 1 when the IN transaction for the corresponding transmit endpoint n has been completed. These bits are cleared to 0 when the corresponding TXSn register is read.	0x0

Table 554: **USB_TXMSK_REG** (0x5004002C)

Bit	Mode	Symbol	Description	Reset
31:7	-	-	Reserved	0x0

Bit	Mode	Symbol	Description	Reset
6:4	R/W	USB_M_TXUDRRN31	The Transmit Mask Register is used to select the bits of the TXEV registers, which causes the TX_EV bit in the MAEV register to be set to 1. When a bit is set to 1 and the corresponding bit in the TXEV register is set to 1, the TX_EV bit in the MAEV register is set to 1. When cleared to 0, the corresponding bit in the TXEV register does not cause TX_EV to be set to 1. Same Bit Definition as TXEV Register	0x0
3	-	-	Reserved	0x0
2:0	R/W	USB_M_TXFIFO31	Same Bit Definition as TXEV Register	0x0

Table 555: **USB_RXEV_REG (0x50040030)**

Bit	Mode	Symbol	Description	Reset
31:7	-	-	Reserved	0x0
6:4	R	USB_RXOVRN31	Receive Overrun n: 3:1 The bit n is set to 1 in the event of an overrun condition in the corresponding receive FIFO n. They are cleared to 0 when the register is read. The firmware must check the respective RX_ERR bits that packets received for the other receive endpoints (EP2, EP4 and EP6,) are not corrupted by errors, as these endpoints support data streaming (packets which are longer than the actual FIFO depth).	0x0
3	-	-	Reserved	0x0
2:0	R	USB_RXFIFO31	Receive FIFO n: 3:1 The bit n is set to 1 whenever either RX_ERR or RX_LAST in the respective Receive Status register (RXSn) is set to 1. Reading the corresponding RXSn register automatically clears these bits. The CoR function is disabled, when the Freeze signal is asserted. The USB node discards all packets for Endpoint 0 received with errors. This is necessary in case of retransmission due to media errors, ensuring that a good copy of a SETUP packet is captured. Otherwise, the FIFO may potentially be tied up, holding corrupted data and unable to receive a retransmission of the same packet. If data streaming is used for the receive endpoints (EP2, EP4 and EP6, EP8) the firmware must check the respective RX_ERR bits to ensure the packets received are not corrupted by errors.	0x0

Table 556: **USB_RXMSK_REG (0x50040034)**

Bit	Mode	Symbol	Description	Reset
31:7	-	-	Reserved	0x0
6:4	R/W	USB_M_RXOVRN31	The Receive Mask Register is used to select the bits of the RXEV registers, which causes the RX_EV bit in the MAEV register to be set to 1. When set to 1 and the corresponding bit in the RXEV register is set to 1, RX_EV bit in the MAEV register is set to 1. When cleared to 0, the corresponding bit in the RXEV register does not	0x0

Bit	Mode	Symbol	Description	Reset
			cause RX_EV to be set to 1. Same Bit Definition as RXEV Register	
3	-	-	Reserved	0x0
2:0	R/W	USB_M_RXFIFO31	Same Bit Definition as RXEV Register	0x0

Table 557: **USB_NAKEV_REG** (0x50040038)

Bit	Mode	Symbol	Description	Reset
31:7	-	-	Reserved	0x0
6:4	R	USB_OUT31	OUT n: 3:1 The bit n is set to 1 when a NAK handshake is generated for an enabled address/endpoint combination (AD_EN in the FAR register is set to 1 and EP_EN in the EPCx register is set to 1) in response to an OUT token. This bit is not set if NAK is generated as result of an overrun condition. It is cleared when the register is read.	0x0
3	-	-	Reserved	0x0
2:0	R	USB_IN31	IN n: 3:1 The bit n is set to 1 when a NAK handshake is generated for an enabled address/endpoint combination (AD_EN in the Function Address, FAR, register is set to 1 and EP_EN in the Endpoint Control, EPCx, register is set to 1) in response to an IN token. This bit is cleared when the register is read.	0x0

Table 558: **USB_NAKMSK_REG** (0x5004003C)

Bit	Mode	Symbol	Description	Reset
31:7	-	-	Reserved	0x0
6:4	R/W	USB_M_OUT31	When set and the corresponding bit in the NAKEV register is set, the NAK bit in the MAEV register is set. When cleared, the corresponding bit in the NAKEV register does not cause NAK to be set. Same Bit Definition as NAKEV Register	0x0
3	-	-	Reserved	0x0
2:0	R/W	USB_M_IN31	Same Bit Definition as NAKEV Register	0x0

Table 559: **USB_FWEV_REG** (0x50040040)

Bit	Mode	Symbol	Description	Reset
31:7	-	-	Reserved	0x0
6:4	R	USB_RXWARN31	Receive Warning n: 3:1 The bit n is set to 1 when the respective receive endpoint FIFO reaches the warning limit, as specified by the RFWL bits of the respective EPCx register. This bit is cleared when the warning condition is cleared by either reading data from the FIFO or when the FIFO is flushed.	0x0
3	-	-	Reserved	0x0
2:0	R	USB_TXWARN31	Transmit Warning n: 3:1	0x0

Bit	Mode	Symbol	Description	Reset
			The bit n is set to 1 when the respective transmit endpoint FIFO reaches the warning limit, as specified by the TFWL bits of the respective TXCn register, and transmission from the respective endpoint is enabled. This bit is cleared when the warning condition is cleared by either writing new data to the FIFO when the FIFO is flushed, or when transmission is done, as indicated by the TX_DONE bit in the TXSn register.	

Table 560: USB_FWMSK_REG (0x50040044)

Bit	Mode	Symbol	Description	Reset
31:7	-	-	Reserved	0x0
6:4	R/W	USB_M_RXWARN31	The FIFO Warning Mask Register selects, which FWEV bits are reported in the MAEV register. A bit set to 1 and the corresponding bit in the FWEV register is set 1, causes the WARN bit in the MAEV register to be set to 1. When cleared to 0, the corresponding bit in the FWEV register does not cause WARN to be set to 1. Same Bit Definition as FWEV Register	0x0
3	-	-	Reserved	0x0
2:0	R/W	USB_M_TXWARN31	The FIFO Warning Mask Register selects, which FWEV bits are reported in the MAEV register. A bit set to 1 and the corresponding bit in the FWEV register is set 1, causes the WARN bit in the MAEV register to be set to 1. When cleared to 0, the corresponding bit in the FWEV register does not cause WARN to be set to 1. Same Bit Definition as FWEV Register	0x0

Table 561: USB_FNH_REG (0x50040048)

Bit	Mode	Symbol	Description	Reset
31:8	-	-	Reserved	0x0
7	R	USB_MF	Missed SOF Flag This flag is set to 1, when the frame number in a valid received SOF does not match the expected next value, or when an SOF is not received within 12060 bit times. This bit is set by the hardware and is cleared by reading the FNH register.	0x1
6	R	USB_UL	Unlock Flag This bit indicates that at least two frames were received without an expected frame number, or that no valid SOF was received within 12060 bit times. If this bit is set, the frame number from the next valid SOF packet is loaded in FN. This bit is set by the hardware and is cleared by reading the FNH register.	0x1
5	R	USB_RFC	Reset Frame Count Writing a 1 to this bit resets the frame number to 00016, after which this bit clears itself to 0 again. This bit always reads 0.	0x0
4:3	-	-	Reserved	0x0
2:0	R	USB_FN_10_8	Frame Number	0x0

Bit	Mode	Symbol	Description	Reset
			<p>This 3-bit field contains the three most significant bits (MSB) of the current frame number, received in the last SOF packet. If a valid frame number is not received within 12060 bit times (Frame Length Maximum, FLMAX, with tolerance) of the previous change, the frame number is incremented artificially. If two successive frames are missed or are incorrect, the current FN is frozen and loaded with the next frame number from a valid SOF packet.</p> <p>If the frame number low byte was read by firmware before reading the FNH register, the user actually reads the contents of a buffer register which holds the value of the three frame number bits of this register when the low byte was read. Therefore, the correct sequence to read the frame number is: FNL, FNH. Read operations to the FNH register, without first reading the Frame Number Low Byte (FNL) register directly, read the actual value of the three MSBs of the frame number.</p>	

Table 562: **USB_FNL_REG (0x5004004C)**

Bit	Mode	Symbol	Description	Reset
31:8	-	-	Reserved	0x0
7:0	R	USB_FN	The Frame Number Low Byte Register holds the low byte of the frame number. To ensure consistency, reading this low byte causes the three frame number bits in the FNH register to be locked until this register is read. The correct sequence to read the frame number is: FNL, FNH.	0x0

Table 563: **USB_UX20CDR_REG (0x5004007C)**

Bit	Mode	Symbol	Description	Reset
31:8	-	-	Reserved	0x0
7	R	RPU_TEST7	Test bit	0x0
6	R/W	RPU_TEST_SW2	<p>0: Closes SW2 switch to reduced pull-up resistor connected to the USB_Dp and USB_Dm.</p> <p>1: Opens SW2 switch resistor connected to the USB_Dp and USB_Dm (independent of the VBus state).</p>	0x0
5	R/W	RPU_TEST_SW1	<p>0: Enable the pull-up resistor on USB_Dp (SW1 closed)</p> <p>1: Disable the pull-up resistor on USB_Dp (SW1 open) (Independent of the VBus state).</p>	0x0
4	R/W	RPU_TEST_EN	<p>Pull-Up Resistor Test Enable</p> <p>0: Normal operation</p> <p>1: Enables the test features controlled by RPU_TEST_SW1, RPU_TEST_SW1DM and RPU_TEST_SW2</p>	0x0
3	-	-	Reserved	0x0
2	R/W	RPU_TEST_SW1DM	<p>0: Enable the pull-up resistor on USB_Dm (SW1DM closed)</p> <p>1: Disable the pull-up resistor on USB_Dm (SW1DM open) (Independent of the VBus state).</p>	0x0

Bit	Mode	Symbol	Description	Reset
1	R/W	RPU_RCDELAY	Test bit, must be kept 0	0x0
0	R/W	RPU_SSPROTEN	Test bit, must be kept 0	0x0

Table 564: **USB_EPC0_REG (0x50040080)**

Bit	Mode	Symbol	Description	Reset
31:8	-	-	Reserved	0x0
7	R/W	USB_STALL	<p>Stall</p> <p>Setting this bit to 1 causes the chip to generate STALL handshakes under the following conditions:</p> <ul style="list-style-type: none"> - The transmit FIFO is enabled and an IN token is received. - The receive FIFO is enabled and an OUT token is received. <p>Note: A SETUP token does not cause a STALL handshake to be generated when this bit is set.</p> <p>Upon transmitting the STALL handshake, the RX_LAST and the TX_DONE bits in the respective Receive/Transmit Status registers are set to 1.</p>	0x0
6	R/W	USB_DEF	<p>Default Address</p> <p>When set to 1, the device responds to the default address regardless of the contents of FAR6-0/EP03-0 fields. When an IN packet is transmitted for the endpoint, the DEF bit is automatically cleared to 0.</p> <p>This bit aids in the transition from default address to assigned address. The transition from the default address 00000000000b to an address assigned during bus enumeration may not occur in the middle of the SET_ADDRESS control sequence. This is necessary to complete the control sequence. However, the address must change immediately after this sequence finishes in order to avoid errors when another control sequence immediately follows the SET_ADDRESS command.</p> <p>On USB reset, the firmware has 10 ms for set-up, and should write 8016 to the FAR register and 0016 to the EPC0 register. On receipt of a SET_ADDRESS command, the firmware must write 4016 to the EPC0 register and (8016 or <assigned_function_address>) to the FAR register. It must then queue a zero length IN packet to complete the status phase of the SET_ADDRESS control sequence.</p>	0x0
5:4	-	-	Reserved	0x0
3:0	R	USB_EP	<p>Endpoint Address</p> <p>This field holds the 4-bit Endpoint address. For Endpoint 0, these bits are hardwired to 0000b. Writing a 1 to any of the EP bits is ignored.</p>	0x0

Table 565: **USB_TXD0_REG (0x50040084)**

Bit	Mode	Symbol	Description	Reset
31:8	-	-	Reserved	0x0
7:0	W	USB_TXFD	Transmit FIFO Data Byte	0x0

Bit	Mode	Symbol	Description	Reset
			The firmware is expected to write only the packet payload data. The PID and CRC16 are created automatically.	

Table 566: **USB_TXS0_REG (0x50040088)**

Bit	Mode	Symbol	Description	Reset
31:7	-	-	Reserved	0x0
6	R	USB_ACK_STAT	Acknowledge Status This bit indicates the status, as received from the host, of the ACK for the packet previously sent. This bit is to be interpreted when TX_DONE is set to 1. It is set to 1, when an ACK is received; otherwise, it remains cleared. This bit is also cleared to 0, when this register is read.	0x0
5	R	USB_TX_DONE	Transmission Done When set to 1, this bit indicates that a packet has completed transmission. It is cleared to 0, when this register is read.	0x0
4:0	R	USB_TCOUNT	Transmission Count This 5-bit field indicates the number of empty bytes available in the FIFO. This field is never larger than 8 for Endpoint 0.	0x8

Table 567: **USB_TXC0_REG (0x5004008C)**

Bit	Mode	Symbol	Description	Reset
31:5	-	-	Reserved	0x0
4	R/W	USB_IGN_IN	Ignore IN Tokens When this bit is set to 1, the endpoint will ignore any IN tokens directed to its configured address.	0x0
3	R/W	USB_FLUSH	Flush FIFO Writing a 1 to this bit flushes all data from the control endpoint FIFOs, resets the endpoint to Idle state, clears the FIFO read and write pointer, and then clears itself. If the endpoint is currently using the FIFO0 to transfer data on USB, flushing is delayed until after the transfer is done. It is equivalent to the FLUSH bit in the RXC0 register.	0x0
2	R/W	USB_TOGGLE_TX0	Toggle This bit specifies the PID used when transmitting the packet. A value of 0 causes a DATA0 PID to be generated, while a value of 1 causes a DATA1 PID to be generated. This bit is not altered by the hardware.	0x0
1	-	-	Reserved	0x0
0	R/W	USB_TX_EN	Transmission Enable This bit enables data transmission from the FIFO. It is cleared to 0 by hardware after transmitting a single packet, or a STALL handshake, in response to an IN token. It must be set to 1 by firmware to start packet transmission. The RX_EN bit in the Receive Command 0 (RXC0) register takes precedence over this bit; i.e. if	0x0

Bit	Mode	Symbol	Description	Reset
			RX_EN is set, TX_EN bit is ignored until RX_EN is reset. Zero length packets are indicated by setting this bit without writing any data to the FIFO.	

Table 568: **USB_EP0_NAK_REG (0x50040090)**

Bit	Mode	Symbol	Description	Reset
31:2	-	-	Reserved	0x0
1	R	USB_EP0_OUTNAK	End point 0 OUT NAK This bit n is set to 1 when a NAK handshake is generated for an enabled address/endpoint combination (AD_EN in the FAR register is set to 1) in response to an OUT token. This bit is not set if NAK is generated as result of an overrun condition. It is cleared when the register is read.	0x0
0	R	USB_EP0_INNAK	End point 0 IN NAK This bit is set to 1 when a NAK handshake is generated for an enabled address/endpoint combination (AD_EN in the FAR register is set to 1) in response to an IN token. This bit is cleared when the register is read.	0x0

Table 569: **USB_RXD0_REG (0x50040094)**

Bit	Mode	Symbol	Description	Reset
31:8	-	-	Reserved	0x0
7:0	R	USB_RXFD	Receive FIFO Data Byte The firmware should expect to read only the packet payload data. The PID and CRC16 are removed from the incoming data stream automatically. In TEST mode this register allow read/write access.	0x0

Table 570: **USB_RXS0_REG (0x50040098)**

Bit	Mode	Symbol	Description	Reset
31:8	-	-	Reserved	0x0
7	-	-	Reserved	0x0
6	R	USB_SETUP	Setup This bit indicates that the setup packet has been received. This bit is unchanged for zero length packets. It is cleared to 0 when this register is read.	0x0
5	R	USB_TOGGLE_RX0	Toggle This bit specified the PID used when receiving the packet. A value of 0 indicates that the last successfully received packet had a DATA0 PID, while a value of 1 indicates that this packet had a DATA1 PID. This bit is unchanged for zero length packets. It is cleared to 0 when this register is read.	0x0
4	R	USB_RX_LAST	Receive Last Bytes	0x0

Bit	Mode	Symbol	Description	Reset
			This bit indicates that an ACK was sent upon completion of a successful receive operation. This bit is unchanged for zero length packets. It is cleared to 0 when this register is read.	
3:0	R	USB_RCOUNT	Receive Count This 4-bit field contains the number of bytes presently in the RX FIFO. This number is never larger than 8 for Endpoint 0.	0x0

Table 571: **USB_RXC0_REG (0x5004009C)**

Bit	Mode	Symbol	Description	Reset
31:6	-	-	Reserved	0x0
5	-	-	Reserved	0x0
4	-	-	Reserved	0x0
3	R/W	USB_FLUSH	Flush Writing a 1 to this bit flushes all data from the control endpoint FIFOs, resets the endpoint to Idle state, clears the FIFO read and write pointer, and then clears itself. If the endpoint is currently using FIFO0 to transfer data on USB, flushing is delayed until after the transfer is done. This bit is cleared to 0 on reset. This bit is equivalent to FLUSH in the TXC0 register.	0x0
2	R/W	USB_IGN_SETUP	Ignore SETUP Tokens When this bit is set to 1, the endpoint ignores any SETUP tokens directed to its configured address.	0x0
1	R/W	USB_IGN_OUT	Ignore OUT Tokens When this bit is set to 1, the endpoint ignores any OUT tokens directed to its configured address.	0x0
0	R/W	USB_RX_EN	Receive Enable OUT packet reception is disabled after every data packet is received, or when a STALL handshake is returned in response to an OUT token. A 1 must be written to this bit to re-enable data reception. Reception of SETUP packets is always enabled. In the case of back-to-back SETUP packets (for a given endpoint) where a valid SETUP packet is received with no other intervening non-SETUP tokens, the Endpoint Controller discards the new SETUP packet and returns an ACK handshake. If any other reasons prevent the Endpoint Controller from accepting the SETUP packet, it must not generate a handshake. This allows recovery from a condition where the ACK of the first SETUP token was lost by the host.	0x0

Table 572: **USB_EPC1_REG (0x500400A0)**

Bit	Mode	Symbol	Description	Reset
31:8	-	-	Reserved	0x0
7	R/W	USB_STALL	Stall Setting this bit to 1 causes the chip to generate STALL handshakes under the following conditions:	0x0

Bit	Mode	Symbol	Description	Reset
			The transmit FIFO is enabled and an IN token is received. The receive FIFO is enabled and an OUT token is received. Setting this bit to 1 does not generate a STALL handshake in response to a SETUP token	
6	-	-	Reserved	0x0
5	R/W	USB_ISO	Isochronous When this bit is set to 1, the endpoint is isochronous. This implies that no NAK is sent if the endpoint is not ready but enabled; i.e. If an IN token is received and no data is available in the FIFO to transmit, or if an OUT token is received and the FIFO is full since there is no USB handshake for isochronous transfers.	0x0
4	R/W	USB_EP_EN	Endpoint Enable When this bit is set to 1, the EP[3:0] field is used in address comparison, together with the AD[6:0] field in the FAR register. When cleared to 0, the endpoint does not respond to any token on the USB bus.	0x0
3:0	R/W	USB_EP	Endpoint Address This 4-bit field holds the endpoint address.	0x0

Table 573: **USB_TXD1_REG (0x500400A4)**

Bit	Mode	Symbol	Description	Reset
31:8	-	-	Reserved	0x0
7:0	W	USB_TXFD	Transmit FIFO Data Byte The firmware is expected to write only the packet payload data. PID and CRC16 are inserted automatically in the transmit data stream. In TEST mode this register allow read/write access via the core bus.	0x0

Table 574: **USB_TXS1_REG (0x500400A8)**

Bit	Mode	Symbol	Description	Reset
31:8	-	-	Reserved	0x0
7	R	USB_TX_URUN	Transmit FIFO Underrun This bit is set to 1, if the transmit FIFO becomes empty during a transmission, and no new data is written to the FIFO. If so, the Media Access Controller (MAC) forces a bit stuff error followed by an EOP. This bit is cleared to 0, when this register is read.	0x0
6	R	USB_ACK_STAT	Acknowledge Status This bit is interpreted when TX_DONE is set. It's function differs depending on whether ISO (ISO in the EPCx register is set) or non-ISO operation (ISO is reset) is used. For non-ISO operation, this bit indicates the acknowledge status (from the host) about the ACK for	0x0

Bit	Mode	Symbol	Description	Reset
			the previously sent packet. This bit itself is set to 1, when an ACK is received; otherwise, it is cleared to 0. For ISO operation, this bit is set if a frame number LSB match (see IGN_ISOMSK bit in the USB_TXCx_REG) occurs, and data was sent in response to an IN token. Otherwise, this bit is cleared to 0, the FIFO is flushed and TX_DONE is set. This bit is also cleared to 0, when this register is read.	
5	R	USB_TX_DONE	Transmission Done When set to 1, this bit indicates that the endpoint responded to a USB packet. Three conditions can cause this bit to be set: A data packet completed transmission in response to an IN token with non-ISO operation. The endpoint sent a STALL handshake in response to an IN token A scheduled ISO frame was transmitted or discarded. This bit is cleared to 0 when this register is read.	0x0
4:0	R	USB_TCOUNT	Transmission Count This 5-bit field holds the number of empty bytes available in the FIFO. If this number is greater than 31, a value of 31 is actually reported.	0x1F

Table 575: USB_TXC1_REG (0x500400AC)

Bit	Mode	Symbol	Description	Reset
31:8	-	-	Reserved	0x0
7	R/W	USB_IGN_ISOMSK	Ignore ISO Mask This bit has an effect only if the endpoint is set to be isochronous. If set to 1, this bit disables locking of specific frame numbers with the alternate function of the TOGGLE bit. Thus data is transmitted upon reception of the next IN token. If cleared to 0, data is only transmitted when FNL0 matches TOGGLE. This bit is cleared to 0 after reset.	0x0
6:5	R/W	USB_TFWL	Transmit FIFO Warning Limit These bits specify how many more bytes can be transmitted from the respective FIFO before an underrun condition occurs. If the number of bytes remaining in the FIFO is equal to or less than the selected warning limit, the TXWARN bit in the FWEV register is set. To avoid interrupts caused by setting this bit while the FIFO is being filled before a transmission begins, TXWARN is only set when transmission from the endpoint is enabled (TX_ENn in the TXCn register is set). TFWL[1:0] : 00: TFWL disabled 01: Less than 5 bytes remaining in FIFO 10: Less than 9 bytes remaining in FIFO 11: Less than 17 bytes remaining in FIFO	0x0
4	R/W	USB_RFF	Refill FIFO Setting the LAST bit to 1 automatically saves the Transmit Read Pointer (TXRP) to a buffer. When the	0x0

Bit	Mode	Symbol	Description	Reset
			RFF bit is set to 1, the buffered TXRP is reloaded into the TXRP. This allows the user to repeat the last transaction if no ACK was received from the host. If the MAC is currently using the FIFO to transmit, TXRP is reloaded only after the transmission is complete. After reload, this bit is cleared to 0 by hardware.	
3	R/W	USB_FLUSH	Flush FIFO Writing a 1 to this bit flushes all data from the corresponding transmit FIFO, resets the endpoint to Idle state, and clears both the FIFO read and write pointers. If the MAC is currently using the FIFO to transmit, data is flushed after the transmission is complete. After data flushing, this bit is cleared to 0 by hardware.	0x0
2	R/W	USB_TOGGLE_TX	Toggle The function of this bit differs depending on whether ISO (ISO bit in the EPCn register is set to 1) or non-ISO operation (ISO bit is cleared to 0) is used. For non-ISO operation, it specifies the PID used when transmitting the packet. A value of 0 causes a DATA0 PID to be generated, while a value of 1 causes a DATA1 PID to be generated. For ISO operation, this bit and the LSB of the frame counter (FNL0) act as a mask for the TX_EN bit to allow pre-queuing of packets to specific frame numbers; i.e. transmission is enabled only if bit 0 in the FNL register is set to TOGGLE. If an IN token is not received while this condition is true, the contents of the FIFO are flushed with the next SOF. If the endpoint is set to ISO, data is always transferred with a DATA0 PID.	0x0
1	R/W	USB_LAST	Last Byte Setting this bit to 1 indicates that the entire packet has been written into the FIFO. This is used especially for streaming data to the FIFO while the actual transmission occurs. If the LAST bit is not set to 1 and the transmit FIFO becomes empty during a transmission, a stuff error followed by an EOP is forced on the bus. Zero length packets are indicated by setting this bit without writing any data to the FIFO. The transmit state machine transmits the payload data, CRC16 and the EOP signal before clearing this bit.	0x0
0	R/W	USB_TX_EN	Transmission Enable This bit enables data transmission from the FIFO. It is cleared to 0 by hardware after transmitting a single packet or after a STALL handshake in response to an IN token. It must be set to 1 by firmware to start packet transmission.	0x0

Table 576: USB_EPC2_REG (0x500400B0)

Bit	Mode	Symbol	Description	Reset
31:8	-	-	Reserved	0x0
7	R/W	USB_STALL	Stall Setting this bit to 1 causes the chip to generate STALL handshakes under the following conditions:	0x0

Bit	Mode	Symbol	Description	Reset
			The transmit FIFO is enabled and an IN token is received. The receive FIFO is enabled and an OUT token is received. Setting this bit to 1 does not generate a STALL handshake in response to a SETUP token	
6	-	-	Reserved	0x0
5	R/W	USB_ISO	Isochronous When this bit is set to 1, the endpoint is isochronous. This implies that no NAK is sent if the endpoint is not ready but enabled; i.e. If an IN token is received and no data is available in the FIFO to transmit, or if an OUT token is received and the FIFO is full since there is no USB handshake for isochronous transfers.	0x0
4	R/W	USB_EP_EN	Endpoint Enable When this bit is set to 1, the EP[3:0] field is used in address comparison, together with the AD[6:0] field in the FAR register. When cleared to 0, the endpoint does not respond to any token on the USB bus.	0x0
3:0	R/W	USB_EP	Endpoint Address This 4-bit field holds the endpoint address.	0x0

Table 577: **USB_RXD1_REG (0x500400B4)**

Bit	Mode	Symbol	Description	Reset
31:8	-	-	Reserved	0x0
7:0	R	USB_RXFD	Receive FIFO Data Byte The firmware should expect to read only the packet payload data. The PID and CRC16 are terminated by the receive state machine. In TEST mode this register allow read/write access via the core bus.	0x0

Table 578: **USB_RXS1_REG (0x500400B8)**

Bit	Mode	Symbol	Description	Reset
14:8	R	USB_RXCOUNT	it contains the number of bytes presently in the endpoint receive FIFO (range 0..64)	0x0
7	R	USB_RX_ERR	Receive Error When set to 1, this bit indicates a media error, such as bit-stuffing or CRC. If this bit is set to 1, the firmware must flush the respective FIFO.	0x0
6	R	USB_SETUP	Setup This bit indicates that the setup packet has been received. It is cleared when this register is read.	0x0
5	R	USB_TOGGLE_RX	Toggle The function of this bit differs depending on whether ISO (ISO in the EPCn register is set) or non-ISO operation (ISO is reset) is used. For non-ISO operation, a value of 0 indicates that the last successfully received packet had a DATA0 PID,	0x0

Bit	Mode	Symbol	Description	Reset
			while a value of 1 indicates that this packet had a DATA1 PID. For ISO operation, this bit reflects the LSB of the frame number (FNL0) after a packet was successfully received for this endpoint. This bit is reset to 0 by reading the RXSn register.	
4	R	USB_RX_LAST	Receive Last This bit indicates that an ACK was sent upon completion of a successful receive operation. This bit is cleared to 0 when this register is read.	0x0
3:0	R	USB_RCOUNT	Receive Counter This 4-bit field contains the number of bytes presently in the endpoint receive FIFO. If this number is greater than 15, a value of 15 is actually reported.	0x0

Table 579: USB_RXC1_REG (0x500400BC)

Bit	Mode	Symbol	Description	Reset
31:7	-	-	Reserved	0x0
6:5	R/W	USB_RFWL	Receive FIFO Warning Limit These bits specify how many more bytes can be received to the respective FIFO before an overrun condition occurs. If the number of empty bytes remaining in the FIFO is equal to or less than the selected warning limit, the RXWARN bit in the FWEV register is set to 1.RFWL[1:0] : 00: RFWL disabled 01: Less than 5 bytes remaining in FIFO 10: Less than 9 bytes remaining in FIFO 11: Less than 17 bytes remaining in FIFO	0x0
4	-	-	Reserved	0x0
3	R/W	USB_FLUSH	Flush FIFO Writing a 1 to this bit flushes all data from the corresponding receive FIFO, resets the endpoint to Idle state, and resets both the FIFO read and write pointers. If the MAC is currently using the FIFO to receive data, flushing is delayed until after receiving is completed.	0x0
2	R/W	USB_IGN_SETUP	Ignore SETUP Tokens When this bit is set to 1, the endpoint ignores any SETUP tokens directed to its configured address.	0x0
1	-	-	Reserved	0x0
0	R/W	USB_RX_EN	Receive Enable OUT packet cannot be received after every data packet is received, or when a STALL handshake is returned in response to an OUT token. This bit must be written with a 1 to re-enable data reception. SETUP packets can always be received. In the case of back-to-back SETUP packets (for a given endpoint) where a valid SETUP packet has been received with no other intervening non-SETUP tokens, the receive state machine discards the new SETUP packet and returns an ACK handshake. If, for any other reason, the receive state machine cannot	0x0

Bit	Mode	Symbol	Description	Reset
			accept the SETUP packet, no HANDSHAKE should be generated.	

Table 580: **USB_EPC3_REG (0x500400C0)**

Bit	Mode	Symbol	Description	Reset
31:8	-	-	Reserved	0x0
7	R/W	USB_STALL	Stall Setting this bit to 1 causes the chip to generate STALL handshakes under the following conditions: The transmit FIFO is enabled and an IN token is received. The receive FIFO is enabled and an OUT token is received. Setting this bit to 1 does not generate a STALL handshake in response to a SETUP token	0x0
6	-	-	Reserved	0x0
5	R/W	USB_ISO	Isochronous When this bit is set to 1, the endpoint is isochronous. This implies that no NAK is sent if the endpoint is not ready but enabled; i.e. If an IN token is received and no data is available in the FIFO to transmit, or if an OUT token is received and the FIFO is full since there is no USB handshake for isochronous transfers.	0x0
4	R/W	USB_EP_EN	Endpoint Enable When this bit is set to 1, the EP[3:0] field is used in address comparison, together with the AD[6:0] field in the FAR register. When cleared to 0, the endpoint does not respond to any token on the USB bus.	0x0
3:0	R/W	USB_EP	Endpoint Address This 4-bit field holds the endpoint address.	0x0

Table 581: **USB_TXD2_REG (0x500400C4)**

Bit	Mode	Symbol	Description	Reset
31:8	-	-	Reserved	0x0
7:0	W	USB_TXFD	Transmit FIFO Data Byte The firmware is expected to write only the packet payload data. PID and CRC16 are inserted automatically in the transmit data stream. In TEST mode this register allow read/write access via the core bus.	0x0

Table 582: **USB_TXS2_REG (0x500400C8)**

Bit	Mode	Symbol	Description	Reset
31:8	-	-	Reserved	0x0
7	R	USB_TX_URUN	Transmit FIFO Underrun This bit is set to 1, if the transmit FIFO becomes empty during a transmission, and no new data is written to the	0x0

Bit	Mode	Symbol	Description	Reset
			FIFO. If so, the Media Access Controller (MAC) forces a bit stuff error followed by an EOP. This bit is cleared to 0, when this register is read.	
6	R	USB_ACK_STAT	<p>Acknowledge Status</p> <p>This bit is interpreted when TX_DONE is set. It's function differs depending on whether ISO (ISO in the EPCx register is set) or non-ISO operation (ISO is reset) is used.</p> <p>For non-ISO operation, this bit indicates the acknowledge status (from the host) about the ACK for the previously sent packet. This bit itself is set to 1, when an ACK is received; otherwise, it is cleared to 0.</p> <p>For ISO operation, this bit is set if a frame number LSB match (see IGN_ISOMSK bit in the USB_TXCx_REG) occurs, and data was sent in response to an IN token. Otherwise, this bit is cleared to 0, the FIFO is flushed and TX_DONE is set.</p> <p>This bit is also cleared to 0, when this register is read.</p>	0x0
5	R	USB_TX_DONE	<p>Transmission Done</p> <p>When set to 1, this bit indicates that the endpoint responded to a USB packet. Three conditions can cause this bit to be set:</p> <p>A data packet completed transmission in response to an IN token with non-ISO operation.</p> <p>The endpoint sent a STALL handshake in response to an IN token</p> <p>A scheduled ISO frame was transmitted or discarded.</p> <p>This bit is cleared to 0 when this register is read.</p>	0x0
4:0	R	USB_TCOUNT	<p>Transmission Count</p> <p>This 5-bit field holds the number of empty bytes available in the FIFO. If this number is greater than 31, a value of 31 is actually reported.</p>	0x1F

Table 583: USB_TXC2_REG (0x500400CC)

Bit	Mode	Symbol	Description	Reset
31:8	-	-	Reserved	0x0
7	R/W	USB_IGN_ISOMSK	<p>Ignore ISO Mask</p> <p>This bit has an effect only if the endpoint is set to be isochronous. If set to 1, this bit disables locking of specific frame numbers with the alternate function of the TOGGLE bit. Thus data is transmitted upon reception of the next IN token. If cleared to 0, data is only transmitted when FNL0 matches TOGGLE. This bit is cleared to 0 after reset.</p>	0x0
6:5	R/W	USB_TFWL	<p>Transmit FIFO Warning Limit</p> <p>These bits specify how many more bytes can be transmitted from the respective FIFO before an underrun condition occurs. If the number of bytes remaining in the FIFO is equal to or less than the selected warning limit, the TXWARN bit in the FWEV register is set. To avoid interrupts caused by setting this bit while the FIFO is being filled before a transmission begins, TXWARN is</p>	0x0

Bit	Mode	Symbol	Description	Reset
			only set when transmission from the endpoint is enabled (TX_ENn in the TXCn register is set). TFWL[1:0] : 00: TFWL disabled 01: Less than 5 bytes remaining in FIFO 10: Less than 9 bytes remaining in FIFO 11: Less than 17 bytes remaining in FIFO	
4	R/W	USB_RFF	Refill FIFO Setting the LAST bit to 1 automatically saves the Transmit Read Pointer (TXRP) to a buffer. When the RFF bit is set to 1, the buffered TXRP is reloaded into the TXRP. This allows the user to repeat the last transaction if no ACK was received from the host. If the MAC is currently using the FIFO to transmit, TXRP is reloaded only after the transmission is complete. After reload, this bit is cleared to 0 by hardware.	0x0
3	R/W	USB_FLUSH	Flush FIFO Writing a 1 to this bit flushes all data from the corresponding transmit FIFO, resets the endpoint to Idle state, and clears both the FIFO read and write pointers. If the MAC is currently using the FIFO to transmit, data is flushed after the transmission is complete. After data flushing, this bit is cleared to 0 by hardware.	0x0
2	R/W	USB_TOGGLE_TX	Toggle The function of this bit differs depending on whether ISO (ISO bit in the EPCn register is set to 1) or non-ISO operation (ISO bit is cleared to 0) is used. For non-ISO operation, it specifies the PID used when transmitting the packet. A value of 0 causes a DATA0 PID to be generated, while a value of 1 causes a DATA1 PID to be generated. For ISO operation, this bit and the LSB of the frame counter (FNL0) act as a mask for the TX_EN bit to allow pre-queuing of packets to specific frame numbers; i.e. transmission is enabled only if bit 0 in the FNL register is set to TOGGLE. If an IN token is not received while this condition is true, the contents of the FIFO are flushed with the next SOF. If the endpoint is set to ISO, data is always transferred with a DATA0 PID.	0x0
1	R/W	USB_LAST	Last Byte Setting this bit to 1 indicates that the entire packet has been written into the FIFO. This is used especially for streaming data to the FIFO while the actual transmission occurs. If the LAST bit is not set to 1 and the transmit FIFO becomes empty during a transmission, a stuff error followed by an EOP is forced on the bus. Zero length packets are indicated by setting this bit without writing any data to the FIFO. The transmit state machine transmits the payload data, CRC16 and the EOP signal before clearing this bit.	0x0
0	R/W	USB_TX_EN	Transmission Enable This bit enables data transmission from the FIFO. It is cleared to 0 by hardware after transmitting a single packet or after a STALL handshake in response to an IN	0x0

Bit	Mode	Symbol	Description	Reset
			token. It must be set to 1 by firmware to start packet transmission.	

Table 584: **USB_EPC4_REG (0x500400D0)**

Bit	Mode	Symbol	Description	Reset
31:8	-	-	Reserved	0x0
7	R/W	USB_STALL	Stall Setting this bit to 1 causes the chip to generate STALL handshakes under the following conditions: The transmit FIFO is enabled and an IN token is received. The receive FIFO is enabled and an OUT token is received. Setting this bit to 1 does not generate a STALL handshake in response to a SETUP token	0x0
6	-	-	Reserved	0x0
5	R/W	USB_ISO	Isochronous When this bit is set to 1, the endpoint is isochronous. This implies that no NAK is sent if the endpoint is not ready but enabled; i.e. If an IN token is received and no data is available in the FIFO to transmit, or if an OUT token is received and the FIFO is full since there is no USB handshake for isochronous transfers.	0x0
4	R/W	USB_EP_EN	Endpoint Enable When this bit is set to 1, the EP[3:0] field is used in address comparison, together with the AD[6:0] field in the FAR register. When cleared to 0, the endpoint does not respond to any token on the USB bus.	0x0
3:0	R/W	USB_EP	Endpoint Address This 4-bit field holds the endpoint address.	0x0

Table 585: **USB_RXD2_REG (0x500400D4)**

Bit	Mode	Symbol	Description	Reset
31:8	-	-	Reserved	0x0
7:0	R	USB_RXFD	Receive FIFO Data Byte The firmware should expect to read only the packet payload data. The PID and CRC16 are terminated by the receive state machine. In TEST mode this register allow read/write access via the core bus.	0x0

Table 586: **USB_RXS2_REG (0x500400D8)**

Bit	Mode	Symbol	Description	Reset
14:8	R	USB_RXCOUNT	it contains the number of bytes presently in the endpoint receive FIFO (range 0..64)	0x0
7	R	USB_RX_ERR	Receive Error	0x0

Bit	Mode	Symbol	Description	Reset
			When set to 1, this bit indicates a media error, such as bit-stuffing or CRC. If this bit is set to 1, the firmware must flush the respective FIFO.	
6	R	USB_SETUP	Setup This bit indicates that the setup packet has been received. It is cleared when this register is read.	0x0
5	R	USB_TOGGLE_RX	Toggle The function of this bit differs depending on whether ISO (ISO in the EPCn register is set) or non-ISO operation (ISO is reset) is used. For non-ISO operation, a value of 0 indicates that the last successfully received packet had a DATA0 PID, while a value of 1 indicates that this packet had a DATA1 PID. For ISO operation, this bit reflects the LSB of the frame number (FNL0) after a packet was successfully received for this endpoint. This bit is reset to 0 by reading the RXSn register.	0x0
4	R	USB_RX_LAST	Receive Last This bit indicates that an ACK was sent upon completion of a successful receive operation. This bit is cleared to 0 when this register is read.	0x0
3:0	R	USB_RCOUNT	Receive Counter This 4-bit field contains the number of bytes presently in the endpoint receive FIFO. If this number is greater than 15, a value of 15 is actually reported.	0x0

Table 587: **USB_RXC2_REG (0x500400DC)**

Bit	Mode	Symbol	Description	Reset
31:7	-	-	Reserved	0x0
6:5	R/W	USB_RFWL	Receive FIFO Warning Limit These bits specify how many more bytes can be received to the respective FIFO before an overrun condition occurs. If the number of empty bytes remaining in the FIFO is equal to or less than the selected warning limit, the RXWARN bit in the FWEV register is set to 1.RFWL[1:0] : 00: RFWL disabled 01: Less than 5 bytes remaining in FIFO 10: Less than 9 bytes remaining in FIFO 11: Less than 17 bytes remaining in FIFO	0x0
4	-	-	Reserved	0x0
3	R/W	USB_FLUSH	Flush FIFO Writing a 1 to this bit flushes all data from the corresponding receive FIFO, resets the endpoint to Idle state, and resets both the FIFO read and write pointers. If the MAC is currently using the FIFO to receive data, flushing is delayed until after receiving is completed.	0x0
2	R/W	USB_IGN_SETUP	Ignore SETUP Tokens	0x0

Bit	Mode	Symbol	Description	Reset
			When this bit is set to 1, the endpoint ignores any SETUP tokens directed to its configured address.	
1	-	-	Reserved	0x0
0	R/W	USB_RX_EN	Receive Enable OUT packet cannot be received after every data packet is received, or when a STALL handshake is returned in response to an OUT token. This bit must be written with a 1 to re-enable data reception. SETUP packets can always be received. In the case of back-to-back SETUP packets (for a given endpoint) where a valid SETUP packet has been received with no other intervening non-SETUP tokens, the receive state machine discards the new SETUP packet and returns an ACK handshake. If, for any other reason, the receive state machine cannot accept the SETUP packet, no HANDSHAKE should be generated.	0x0

Table 588: **USB_EPC5_REG (0x500400E0)**

Bit	Mode	Symbol	Description	Reset
31:8	-	-	Reserved	0x0
7	R/W	USB_STALL	Stall Setting this bit to 1 causes the chip to generate STALL handshakes under the following conditions: The transmit FIFO is enabled and an IN token is received. The receive FIFO is enabled and an OUT token is received. Setting this bit to 1 does not generate a STALL handshake in response to a SETUP token	0x0
6	-	-	Reserved	0x0
5	R/W	USB_ISO	Isochronous When this bit is set to 1, the endpoint is isochronous. This implies that no NAK is sent if the endpoint is not ready but enabled; i.e. If an IN token is received and no data is available in the FIFO to transmit, or if an OUT token is received and the FIFO is full since there is no USB handshake for isochronous transfers.	0x0
4	R/W	USB_EP_EN	Endpoint Enable When this bit is set to 1, the EP[3:0] field is used in address comparison, together with the AD[6:0] field in the FAR register. When cleared to 0, the endpoint does not respond to any token on the USB bus.	0x0
3:0	R/W	USB_EP	Endpoint Address This 4-bit field holds the endpoint address.	0x0

Table 589: **USB_TXD3_REG (0x500400E4)**

Bit	Mode	Symbol	Description	Reset
31:8	-	-	Reserved	0x0
7:0	W	USB_TXFD	Transmit FIFO Data Byte	0x0

Bit	Mode	Symbol	Description	Reset
			The firmware is expected to write only the packet payload data. PID and CRC16 are inserted automatically in the transmit data stream. In TEST mode this register allow read/write access via the core bus.	

Table 590: **USB_TXS3_REG (0x500400E8)**

Bit	Mode	Symbol	Description	Reset
31:8	-	-	Reserved	0x0
7	R	USB_TX_URUN	Transmit FIFO Underrun This bit is set to 1, if the transmit FIFO becomes empty during a transmission, and no new data is written to the FIFO. If so, the Media Access Controller (MAC) forces a bit stuff error followed by an EOP. This bit is cleared to 0, when this register is read.	0x0
6	R	USB_ACK_STAT	Acknowledge Status This bit is interpreted when TX_DONE is set. It's function differs depending on whether ISO (ISO in the EPCx register is set) or non-ISO operation (ISO is reset) is used. For non-ISO operation, this bit indicates the acknowledge status (from the host) about the ACK for the previously sent packet. This bit itself is set to 1, when an ACK is received; otherwise, it is cleared to 0. For ISO operation, this bit is set if a frame number LSB match (see IGN_ISOMSK bit in the USB_TXCx_REG) occurs, and data was sent in response to an IN token. Otherwise, this bit is cleared to 0, the FIFO is flushed and TX_DONE is set. This bit is also cleared to 0, when this register is read.	0x0
5	R	USB_TX_DONE	Transmission Done When set to 1, this bit indicates that the endpoint responded to a USB packet. Three conditions can cause this bit to be set: A data packet completed transmission in response to an IN token with non-ISO operation. The endpoint sent a STALL handshake in response to an IN token A scheduled ISO frame was transmitted or discarded. This bit is cleared to 0 when this register is read.	0x0
4:0	R	USB_TCOUNT	Transmission Count This 5-bit field holds the number of empty bytes available in the FIFO. If this number is greater than 31, a value of 31 is actually reported.	0x1F

Table 591: **USB_TXC3_REG (0x500400EC)**

Bit	Mode	Symbol	Description	Reset
31:8	-	-	Reserved	0x0
7	R/W	USB_IGN_ISOMSK	Ignore ISO Mask	0x0

Bit	Mode	Symbol	Description	Reset
			This bit has an effect only if the endpoint is set to be isochronous. If set to 1, this bit disables locking of specific frame numbers with the alternate function of the TOGGLE bit. Thus data is transmitted upon reception of the next IN token. If cleared to 0, data is only transmitted when FNL0 matches TOGGLE. This bit is cleared to 0 after reset.	
6:5	R/W	USB_TFWL	<p>Transmit FIFO Warning Limit</p> <p>These bits specify how many more bytes can be transmitted from the respective FIFO before an underrun condition occurs. If the number of bytes remaining in the FIFO is equal to or less than the selected warning limit, the TXWARN bit in the FWEV register is set. To avoid interrupts caused by setting this bit while the FIFO is being filled before a transmission begins, TXWARN is only set when transmission from the endpoint is enabled (TX_ENn in the TXCn register is set).</p> <p>TFWL[1:0] :</p> <p>00: TFWL disabled</p> <p>01: Less than 5 bytes remaining in FIFO</p> <p>10: Less than 9 bytes remaining in FIFO</p> <p>11: Less than 17 bytes remaining in FIFO</p>	0x0
4	R/W	USB_RFF	<p>Refill FIFO</p> <p>Setting the LAST bit to 1 automatically saves the Transmit Read Pointer (TXRP) to a buffer. When the RFF bit is set to 1, the buffered TXRP is reloaded into the TXRP. This allows the user to repeat the last transaction if no ACK was received from the host. If the MAC is currently using the FIFO to transmit, TXRP is reloaded only after the transmission is complete. After reload, this bit is cleared to 0 by hardware.</p>	0x0
3	R/W	USB_FLUSH	<p>Flush FIFO</p> <p>Writing a 1 to this bit flushes all data from the corresponding transmit FIFO, resets the endpoint to Idle state, and clears both the FIFO read and write pointers. If the MAC is currently using the FIFO to transmit, data is flushed after the transmission is complete. After data flushing, this bit is cleared to 0 by hardware.</p>	0x0
2	R/W	USB_TOGGLE_TX	<p>Toggle</p> <p>The function of this bit differs depending on whether ISO (ISO bit in the EPCn register is set to 1) or non-ISO operation (ISO bit is cleared to 0) is used.</p> <p>For non-ISO operation, it specifies the PID used when transmitting the packet. A value of 0 causes a DATA0 PID to be generated, while a value of 1 causes a DATA1 PID to be generated.</p> <p>For ISO operation, this bit and the LSB of the frame counter (FNL0) act as a mask for the TX_EN bit to allow pre-queuing of packets to specific frame numbers; i.e. transmission is enabled only if bit 0 in the FNL register is set to TOGGLE. If an IN token is not received while this condition is true, the contents of the FIFO are flushed with the next SOF. If the endpoint is set to ISO, data is always transferred with a DATA0 PID.</p>	0x0
1	R/W	USB_LAST	Last Byte	0x0

Bit	Mode	Symbol	Description	Reset
			Setting this bit to 1 indicates that the entire packet has been written into the FIFO. This is used especially for streaming data to the FIFO while the actual transmission occurs. If the LAST bit is not set to 1 and the transmit FIFO becomes empty during a transmission, a stuff error followed by an EOP is forced on the bus. Zero length packets are indicated by setting this bit without writing any data to the FIFO. The transmit state machine transmits the payload data, CRC16 and the EOP signal before clearing this bit.	
0	R/W	USB_TX_EN	Transmission Enable This bit enables data transmission from the FIFO. It is cleared to 0 by hardware after transmitting a single packet or after a STALL handshake in response to an IN token. It must be set to 1 by firmware to start packet transmission.	0x0

Table 592: USB_EPC6_REG (0x500400F0)

Bit	Mode	Symbol	Description	Reset
31:8	-	-	Reserved	0x0
7	R/W	USB_STALL	Stall Setting this bit to 1 causes the chip to generate STALL handshakes under the following conditions: The transmit FIFO is enabled and an IN token is received. The receive FIFO is enabled and an OUT token is received. Setting this bit to 1 does not generate a STALL handshake in response to a SETUP token	0x0
6	-	-	Reserved	0x0
5	R/W	USB_ISO	Isochronous When this bit is set to 1, the endpoint is isochronous. This implies that no NAK is sent if the endpoint is not ready but enabled; i.e. If an IN token is received and no data is available in the FIFO to transmit, or if an OUT token is received and the FIFO is full since there is no USB handshake for isochronous transfers.	0x0
4	R/W	USB_EP_EN	Endpoint Enable When this bit is set to 1, the EP[3:0] field is used in address comparison, together with the AD[6:0] field in the FAR register. When cleared to 0, the endpoint does not respond to any token on the USB bus.	0x0
3:0	R/W	USB_EP	Endpoint Address This 4-bit field holds the endpoint address.	0x0

Table 593: USB_RXD3_REG (0x500400F4)

Bit	Mode	Symbol	Description	Reset
31:8	-	-	Reserved	0x0
7:0	R	USB_RXFD	Receive FIFO Data Byte	0x0

Bit	Mode	Symbol	Description	Reset
			The firmware should expect to read only the packet payload data. The PID and CRC16 are terminated by the receive state machine. In TEST mode this register allow read/write access via the core bus.	

Table 594: **USB_RXS3_REG (0x500400F8)**

Bit	Mode	Symbol	Description	Reset
14:8	R	USB_RXCOUNT	it contains the number of bytes presently in the endpoint receive FIFO (range 0..64)	0x0
7	R	USB_RX_ERR	Receive Error When set to 1, this bit indicates a media error, such as bit-stuffing or CRC. If this bit is set to 1, the firmware must flush the respective FIFO.	0x0
6	R	USB_SETUP	Setup This bit indicates that the setup packet has been received. It is cleared when this register is read.	0x0
5	R	USB_TOGGLE_RX	Toggle The function of this bit differs depending on whether ISO (ISO in the EPCn register is set) or non-ISO operation (ISO is reset) is used. For non-ISO operation, a value of 0 indicates that the last successfully received packet had a DATA0 PID, while a value of 1 indicates that this packet had a DATA1 PID. For ISO operation, this bit reflects the LSB of the frame number (FNL0) after a packet was successfully received for this endpoint. This bit is reset to 0 by reading the RXSn register.	0x0
4	R	USB_RX_LAST	Receive Last This bit indicates that an ACK was sent upon completion of a successful receive operation. This bit is cleared to 0 when this register is read.	0x0
3:0	R	USB_RCOUNT	Receive Counter This 4-bit field contains the number of bytes presently in the endpoint receive FIFO. If this number is greater than 15, a value of 15 is actually reported.	0x0

Table 595: **USB_RXC3_REG (0x500400FC)**

Bit	Mode	Symbol	Description	Reset
31:7	-	-	Reserved	0x0
6:5	R/W	USB_RFWL	Receive FIFO Warning Limit These bits specify how many more bytes can be received to the respective FIFO before an overrun condition occurs. If the number of empty bytes remaining in the FIFO is equal to or less than the selected warning limit, the RXWARN bit in the FWEV register is set to 1.RFWL[1:0] : 00: RFWL disabled	0x0

Bit	Mode	Symbol	Description	Reset
			01: Less than 5 bytes remaining in FIFO 10: Less than 9 bytes remaining in FIFO 11: Less than 17 bytes remaining in FIFO	
4	-	-	Reserved	0x0
3	R/W	USB_FLUSH	Flush FIFO Writing a 1 to this bit flushes all data from the corresponding receive FIFO, resets the endpoint to Idle state, and resets both the FIFO read and write pointers. If the MAC is currently using the FIFO to receive data, flushing is delayed until after receiving is completed.	0x0
2	R/W	USB_IGN_SETUP	Ignore SETUP Tokens When this bit is set to 1, the endpoint ignores any SETUP tokens directed to its configured address.	0x0
1	-	-	Reserved	0x0
0	R/W	USB_RX_EN	Receive Enable OUT packet cannot be received after every data packet is received, or when a STALL handshake is returned in response to an OUT token. This bit must be written with a 1 to re-enable data reception. SETUP packets can always be received. In the case of back-to-back SETUP packets (for a given endpoint) where a valid SETUP packet has been received with no other intervening non-SETUP tokens, the receive state machine discards the new SETUP packet and returns an ACK handshake. If, for any other reason, the receive state machine cannot accept the SETUP packet, no HANDSHAKE should be generated.	0x0

Table 596: **USB_DMA_CTRL_REG (0x500401A0)**

Bit	Mode	Symbol	Description	Reset
31:7	-	-	Reserved	0x0
6	R/W	USB_DMA_EN	0 = USB DMA control off. (Normal operation) 1 = USB_DMA on. DMA channels 0 and 1 are connected by USB Endpoint according bits USB_DMA_TX and USB_DMA_RX	0x0
5:3	R/W	USB_DMA_TX	000 = DMA channels 1 is connected Tx USB Endpoint 1 001 = DMA channels 1 is connected Tx USB Endpoint 3 010 = DMA channels 1 is connected Tx USB Endpoint 5 100, 1xx = Reserved	0x0
2:0	R/W	USB_DMA_RX	000 = DMA channels 0 is connected Rx USB Endpoint 2 001 = DMA channels 0 is connected Rx USB Endpoint 4 010 = DMA channels 0 is connected Rx USB Endpoint 6 100, 1xx = Reserved	0x0

Table 597: **USB_CHARGER_CTRL_REG (0x500401A8)**

Bit	Mode	Symbol	Description	Reset
31:6	-	-	Reserved	0x0

Bit	Mode	Symbol	Description	Reset
5	R/W	IDM_SINK_ON	0 = Disable 1 = Enable the Idm_sink to USBm	0x0
4	R/W	IDP_SINK_ON	0 = Disable 1 = Enable the Idp_sink to USBp	0x0
3	R/W	VDM_SRC_ON	0 = Disable 1 = Enable Vdm_src to USBm and USB_DCP_DET status bit.	0x0
2	R/W	VDP_SRC_ON	0 = Disable 1 = Enable the Vdp_src to USB_CHG_DET status bit.	0x0
1	R/W	IDP_SRC_ON	0 = Disable 1 = Enable the Idp_src and Rdm_dwn.	0x0
0	R/W	USB_CHARGE_ON	0 = Disable USB charger detect circuit. 1 = Enable USB charger detect circuit.	0x0

Table 598: **USB_CHARGER_STAT_REG (0x500401AC)**

Bit	Mode	Symbol	Description	Reset
31:6	R	-	Reserved	0x0
5	R	USB_DM_VAL2	0 = USBm <2.3V 1 = USBm >2.5V	0x0
4	R	USB_DP_VAL2	0: USBp < 2.3V 1: USBp > 2.5V	0x0
3	R	USB_DM_VAL	0 = USBm < 0.8V 1 = USBm > 1.5V (PS2 or Proprietary Charger)	0x0
2	R	USB_DP_VAL	0 = USBp < 0.8V 1 = USBp > 1.5V	0x0
1	R	USB_CHG_DET	0 = Standard downstream or nothing connected. 1 = Charging Downstream Port (CDP) or Dedicated Charging.	0x0
0	R	USB_DCP_DET	0 = Charging downstream port is detected. 1 = Dedicated charger is detected. Control bit VDM_SRC_ON must be set to validate this status bit. Note: This register shows the actual status.	0x0

42.18 Silicon Version Registers

Table 599: Register map Version

Address	Register	Description
0x50040200	CHIP_ID1_REG	Chip identification register 1.
0x50040204	CHIP_ID2_REG	Chip identification register 2.
0x50040208	CHIP_ID3_REG	Chip identification register 3.
0x5004020C	CHIP_ID4_REG	Chip identification register 4.

Address	Register	Description
0x50040210	CHIP_SWC_REG	Software compatibility register.
0x50040214	CHIP_REVISION_REG	Chip revision register.
0x500402F8	CHIP_TEST1_REG	Chip test register 1.
0x500402FC	CHIP_TEST2_REG	Chip test register 2.

Table 600: CHIP_ID1_REG (0x50040200)

Bit	Mode	Symbol	Description	Reset
31:8	R	-	Reserved	0x0
7:0	R	CHIP_ID1	First character of device type in ASCII.	0x33

Table 601: CHIP_ID2_REG (0x50040204)

Bit	Mode	Symbol	Description	Reset
31:8	R	-	Reserved	0x0
7:0	R	CHIP_ID2	Second character of device type in ASCII.	0x30

Table 602: CHIP_ID3_REG (0x50040208)

Bit	Mode	Symbol	Description	Reset
31:8	R	-	Reserved	0x0
7:0	R	CHIP_ID3	Third character of device type in ASCII.	0x38

Table 603: CHIP_ID4_REG (0x5004020C)

Bit	Mode	Symbol	Description	Reset
31:8	R	-	Reserved	0x0
7:0	R	CHIP_ID4	Fourth character of device type in ASCII.	0x30

Table 604: CHIP_SWC_REG (0x50040210)

Bit	Mode	Symbol	Description	Reset
31:4	R	-	Reserved	0x0
3:0	R	CHIP_SWC	SoftWare Compatibility code. Integer (default = 0) which is incremented if a silicon change has impact on the CPU Firmware. Can be used by software developers to write silicon revision dependent code.	0x0

Table 605: CHIP_REVISION_REG (0x50040214)

Bit	Mode	Symbol	Description	Reset
31:8	R	-	Reserved	0x0
7:0	R	CHIP_REVISION	Chip version, corresponds with type number in ASCII. 0x41 = 'A', 0x42 = 'B'	0x41

Table 606: **CHIP_TEST1_REG** (0x500402F8)

Bit	Mode	Symbol	Description	Reset
31:8	R	-	Reserved	0x0
7:0	R	CHIP_LAYOUT_REVISION	Chip layout revision, corresponds with type number in ASCII. 0x41 = 'A', 0x42 = 'B'	0x41

Table 607: **CHIP_TEST2_REG** (0x500402FC)

Bit	Mode	Symbol	Description	Reset
31:4	R	-	Reserved	0x0
3:0	R	CHIP_METAL_OPTION	Chip metal option value.	0x0

42.19 Wake-Up Controller Registers

Table 608: Register map WakeUp

Address	Register	Description
0x50000100	WKUP_CTRL_REG	Control register for the wakeup counter
0x50000108	WKUP_RESET_IRQ_REG	Reset wakeup interrupt
0x50000114	WKUP_SELECT_P0_REG	select which inputs from P0 port can trigger wkup counter
0x50000118	WKUP_SELECT_P1_REG	select which inputs from P1 port can trigger wkup counter
0x50000128	WKUP_POL_P0_REG	select the sensitivity polarity for each P0 input
0x5000012C	WKUP_POL_P1_REG	select the sensitivity polarity for each P1 input
0x5000013C	WKUP_STATUS_P0_REG	Event status register for P0
0x50000140	WKUP_STATUS_P1_REG	Event status register for P1
0x50000148	WKUP_CLEAR_P0_REG	Clear event register for P0
0x5000014C	WKUP_CLEAR_P1_REG	Clear event register for P1
0x50000154	WKUP_SEL_GPIO_P0_REG	select which inputs from P0 port can trigger interrupt
0x50000158	WKUP_SEL_GPIO_P1_REG	select which inputs from P1 port can trigger interrupt

Table 609: **WKUP_CTRL_REG** (0x50000100)

Bit	Mode	Symbol	Description	Reset
15:8	-	-	Reserved	0x0
7	R/W	WKUP_ENABLE_IRQ	0: no interrupt will be enabled 1: if you have an event an IRQ will be generated	0x0
6	R/W	WKUP_SFT_KEYHIT	0 = no effect	0x0

Bit	Mode	Symbol	Description	Reset
			1 = emulate key hit. First make this bit 0 before any new key hit can be sensed.	
5:0	R/W	WKUP_DEB_VALUE	Wakeup debounce time. If set to 0, no debouncing will be done. Debounce time: N*1 ms. N = 1..63	0x0

Table 610: **WKUP_RESET_IRQ_REG (0x50000108)**

Bit	Mode	Symbol	Description	Reset
15:0	W	WKUP_IRQ_RST	writing any value to this register will reset the interrupt. reading always returns 0.	0x0

Table 611: **WKUP_SELECT_P0_REG (0x50000114)**

Bit	Mode	Symbol	Description	Reset
31:0	R/W	WKUP_SELECT_P0	0: input P0_xx is not enabled for wakeup event 1: input P0_xx is enabled for wakeup event	0x0

Table 612: **WKUP_SELECT_P1_REG (0x50000118)**

Bit	Mode	Symbol	Description	Reset
22:0	R/W	WKUP_SELECT_P1	0: input P1_xx is not enabled for wakeup event 1: input P1_xx is enabled for wakeup event	0x0

Table 613: **WKUP_POL_P0_REG (0x50000128)**

Bit	Mode	Symbol	Description	Reset
31:0	R/W	WKUP_POL_P0	0: enabled input P0_xx will give an event if that input goes high 1: enabled input P0_xx will give an event if that input goes low	0x0

Table 614: **WKUP_POL_P1_REG (0x5000012C)**

Bit	Mode	Symbol	Description	Reset
22:0	R/W	WKUP_POL_P1	0: enabled input P1_xx will give an event if that input goes high 1: enabled input P1_xx will give an event if that input goes low	0x0

Table 615: **WKUP_STATUS_P0_REG (0x5000013C)**

Bit	Mode	Symbol	Description	Reset
31:0	R	WKUP_STAT_P0	Contains the latched value of any toggle of the GPIOs Port P0. WKUP_STAT_P0[0] -> P0_00.	0x0

Table 616: [WKUP_STATUS_P1_REG \(0x50000140\)](#)

Bit	Mode	Symbol	Description	Reset
22:0	R	WKUP_STAT_P1	Contains the latched value of any toggle of the GPIOs Port P1. WKUP_STAT_P1[0] -> P1_00.	0x0

Table 617: [WKUP_CLEAR_P0_REG \(0x50000148\)](#)

Bit	Mode	Symbol	Description	Reset
31:0	W	WKUP_CLEAR_P0	Clear latched value of the GPIOs P0 when corresponding bit is 1	0x0

Table 618: [WKUP_CLEAR_P1_REG \(0x5000014C\)](#)

Bit	Mode	Symbol	Description	Reset
22:0	W	WKUP_CLEAR_P1	Clear latched value of the GPIOs P1 when corresponding bit is 1	0x0

Table 619: [WKUP_SEL_GPIO_P0_REG \(0x50000154\)](#)

Bit	Mode	Symbol	Description	Reset
31:0	R/W	WKUP_SEL_GPIO_P0	0: input P0_xx is not enabled for GPIO interrupt 1: input P0_xx is enabled for GPIO interrupt	0x0

Table 620: [WKUP_SEL_GPIO_P1_REG \(0x50000158\)](#)

Bit	Mode	Symbol	Description	Reset
22:0	R/W	WKUP_SEL_GPIO_P1	0: input P1_xx is not enabled for GPIO interrupt 1: input P1_xx is enabled for GPIO interrupt	0x0

42.20 Watchdog Controller Registers

Table 621: Register map WDOG

Address	Register	Description
0x50000700	WATCHDOG_REG	Watchdog timer register.
0x50000704	WATCHDOG_CTRL_REG	Watchdog control register.

Table 622: [WATCHDOG_REG \(0x50000700\)](#)

Bit	Mode	Symbol	Description	Reset
31:14	R0/W	WDOG_WEN	Bit [31:14] = 0 = Write enable for Watchdog timer else Write disable. This filter prevents unintentional presetting the watchdog with a SW run-away.	0x0
13	R/W	WDOG_VAL_NEG	0 = Watchdog timer value is positive. 1 = Watchdog timer value is negative.	0x0

Bit	Mode	Symbol	Description	Reset
12:0	R/W	WDOG_VAL	<p><u>Write</u>: Watchdog timer reload value. Note that all bits [31-14] must be 0 to reload this register.</p> <p><u>Read</u>: Actual Watchdog timer value. Decremented by 1 every ~10 msec (RC32K) or ~29 msec (RCX), i.e. the Watchdog timer clock tick.</p> <p>Bit 13 indicates a negative counter value. 2, 1, 0, 3FFF₁₆, 3FFE₁₆ etc. An NMI or WDOG (SYS) reset is generated under the following conditions:</p> <p>If WATCHDOG_CTRL_REG[NMI_RST] = 0 then</p> <p style="padding-left: 20px;">If WDOG_VAL = 0 -> NMI (Non Maskable Interrupt)</p> <p style="padding-left: 20px;">if WDOG_VAL = 3FFF₁₆ -> WDOG reset -> reload 1FFF₁₆</p> <p>If WATCHDOG_CTRL_REG[NMI_RST] = 1 then</p> <p style="padding-left: 20px;">if WDOG_VAL <= 0 -> WDOG reset -> reload 1FFF₁₆</p> <p>Note 1: The programmed value WDOG_VAL is updated in the (independent) Watchdog timer at the 2nd next RC32K or RCX clock tick.</p> <p>Note 2: Select RC32K or RCX with CLK_RCX_REG[RCX_ENABLE]. The RC32K is selected by default.</p> <p>Note 3: If WATCHDOG_CTRL_REG[NMI_RST] = 0, the time between the NMI generation and the WDOG reset generation is 15 Watchdog timer clock ticks.</p>	0x1FFF

Table 623: WATCHDOG_CTRL_REG (0x50000704)

Bit	Mode	Symbol	Description	Reset
31:4	R	-	Reserved	0x0
3	R	WRITE_BUSY	<p>0 = A new WATCHDOG_REG[WDOG_VAL] can be written.</p> <p>1 = No new WATCHDOG_REG[WDOG_VAL] can be written.</p> <p>Note: It takes some time before the programmed WDOG_VAL is updated in the (independent) Watchdog timer. During this time it is not possible to write a new value to WATCHDOG_REG[WDOG_VAL].</p>	0x0
2	R/W	WDOG_FREEZE_EN	<p>0 = Watchdog timer can not be frozen when NMI_RST=0.</p> <p>1 = Watchdog timer can be frozen/resumed using SET_FREEZE_REG[FRZ_WDOG]/RESET_FREEZE_REG[FRZ_WDOG] when NMI_RST=0.</p> <p>Note: Although this bit is retained during sleep, the SET_FREEZE_REG[FRZ_SYS_WDOG] is not, so the watchdog cannot be frozen during CM33 sleep.</p>	0x1
1	R/W	-	Reserved	0x1
0	R/W	NMI_RST	<p>0 = Watchdog timer generates NMI at value 0, and WDOG (SYS) reset at <= -16. Timer can be frozen/resumed using SET_FREEZE_REG[FRZ_WDOG]/RESET_FREEZE_REG[FRZ_WDOG].</p> <p>1 = Watchdog timer generates a WDOG (SYS) reset at value 0 and can not be frozen by Software.</p> <p>Note that this bit can only be set to 1 by software and</p>	0x0

Bit	Mode	Symbol	Description	Reset
			only be reset with a WDOG (SYS) reset or software reset. The watchdog is always frozen when the Cortex-M33 is halted in DEBUG State.	

42.21 General Purpose / ΣΔ ADC Registers

Table 624: Register map GPADC

Address	Register	Description
0x50020800	SDADC_CTRL_REG	Sigma Delta ADC Control Register
0x50020808	SDADC_TEST_REG	Sigma Delta ADC Test Register
0x5002080C	SDADC_GAIN_CORR_REG	Sigma Delta ADC Gain Correction Register
0x50020810	SDADC_OFFS_CORR_REG	Sigma Delta ADC Offset Correction Register
0x50020814	SDADC_CLEAR_INT_REG	Sigma Delta ADC Clear Interrupt Register
0x50020818	SDADC_RESULT_REG	Sigma Delta ADC Result Register
0x50030900	GP_ADC_CTRL_REG	General Purpose ADC Control Register
0x50030904	GP_ADC_CTRL2_REG	General Purpose ADC Second Control Register
0x50030908	GP_ADC_CTRL3_REG	General Purpose ADC Third Control Register
0x5003090C	GP_ADC_OFFP_REG	General Purpose ADC Positive Offset Register
0x50030910	GP_ADC_OFFN_REG	General Purpose ADC Negative Offset Register
0x50030914	GP_ADC_CLEAR_INT_REG	General Purpose ADC Clear Interrupt Register
0x50030918	GP_ADC_RESULT_REG	General Purpose ADC Result Register

Table 625: [SDADC_CTRL_REG](#) (0x50020800)

Bit	Mode	Symbol	Description	Reset
17	R/W	SDADC_DMA_EN	0: DMA functionality disabled 1: DMA functionality enabled	0x0
16	R/W	SDADC_MINT	0: Disable (mask) SDADC_ADC_INT. 1: Enable SDADC_ADC_INT to ICU.	0x0
15	R	SDADC_INT	1: AD conversion ready and has generated an interrupt. Must be cleared by writing any value to SDADC_CLEAR_INT_REG.	0x0
14	R	SDADC_LDO_OK	1: Internal LDO is ready for use	0x0
13	R/W	SDADC_VREF_SEL	0: Internal bandgap reference. 1: External reference.	0x0
12	R/W	SDADC_CONT	0: Manual ADC mode, a single result will be generated after setting the SDADC_START bit. 1: Continuous ADC mode, new ADC results will be constantly stored in SDADC_RESULT_REG. Still SDADC_START has to be set to start the execution.	0x0

Bit	Mode	Symbol	Description	Reset
			Wait for SDADC_START to become zero after clearing the SDADC_CONT bit to stop the continuous mode.	
11:10	R/W	SDADC_OSR	Oversample Rate 0: 128x 1: 256x 2: 512x 3: 1024x	0x0
9	R/W	SDADC_SE	0: Differential mode 1: Single ended mode (Input selection negative side is ignored)	0x0
8:6	R/W	SDADC_INN_SEL	Input selection of negative side. 0: ADC0 / P1[09] 1: ADC1 / P0[25] 2: ADC2 / P0[08] 3: ADC3 / P0[09] 4: ADC4 / P1[14] 5: ADC5 / P1[20] 6: ADC6 / P1[21] 7: ADC7 / P1[22]	0x0
5:2	R/W	SDADC_INP_SEL	Input selection of positive side. 0: ADC0 / P1[09] 1: ADC1 / P0[25] 2: ADC2 / P0[08] 3: ADC3 / P0[09] 4: ADC4 / P1[14] 5: ADC5 / P1[20] 6: ADC6 / P1[21] 7: ADC7 / P1[22] 8: VBAT (via 4x attenuator, INN connected to ground)	0x0
1	R/W	SDADC_START	0: ADC conversion ready. 1: If a 1 is written, the ADC starts a conversion. After the conversion this bit will be set to 0 and the SDADC_INT bit will be set. It is not allowed to write this bit while it is not (yet) zero.	0x0
0	R/W	SDADC_EN	0: LDO is off and ADC is disabled. 1: LDO, bias currents and modulator are enabled.	0x0

Table 626: SDADC_TEST_REG (0x50020808)

Bit	Mode	Symbol	Description	Reset
15:11	R/W	-	Reserved	0xF
10	R/W	-	Reserved	0x0
9:8	R/W	-	Reserved	0x1
7:6	R/W	SDADC_CLK_FREQ	0: 250 kHz 1: 500 kHz 2: 1 MHz (default) 3: 2 MHz	0x2

Bit	Mode	Symbol	Description	Reset
5	R/W	-	Reserved	0x0
4	R/W	-	Reserved	0x0
3	R/W	-	Reserved	0x0
2	R/W	-	Reserved	0x0
1	R/W	-	Reserved	0x0
0	R/W	-	Reserved	0x0

Table 627: SDADC_GAIN_CORR_REG (0x5002080C)

Bit	Mode	Symbol	Description	Reset
9:0	R/W	SDADC_GAIN_CORR	Gain adjust	0x0

Table 628: SDADC_OFFS_CORR_REG (0x50020810)

Bit	Mode	Symbol	Description	Reset
9:0	R/W	SDADC_OFFS_CORR	Offset adjust	0x0

Table 629: SDADC_CLEAR_INT_REG (0x50020814)

Bit	Mode	Symbol	Description	Reset
15:0	R0/W	SDADC_CLR_INT	Writing any value to this register will clear the ADC_INT interrupt. Reading returns 0.	0x0

Table 630: SDADC_RESULT_REG (0x50020818)

Bit	Mode	Symbol	Description	Reset
15:0	R	SDADC_VAL	Returns up to 16 bits linear value of the last AD conversion. The effective resolution depends on the OSR used.	0x0

Table 631: GP_ADC_CTRL_REG (0x50030900)

Bit	Mode	Symbol	Description	Reset
18	R/W	GP_ADC_DIFF_TEMP_EN	1: Enable the on-chip temperature sensors	0x0
17:16	R/W	GP_ADC_DIFF_TEMP_SEL	0= Gnd, 1 =sensor near radio, 2 =sensor near charger, 3 =sensor near bandgap with sensors disabled (GP_ADC_DIFF_TEMP_EN = 0) :0 = GND 1 = Z, 2= V(ntc) from charger, 3 = V(temp) from charger	0x0
15	R/W	GP_ADC_LDO_ZERO	1: Samples and disconnects VREF, should be refreshed frequently. Note that the LDO consumes power when bit is set.	0x0
14	R/W	GP_ADC_CHOP	0: Chopper mode off 1: Chopper mode enabled. Takes two samples with opposite GP_ADC_SIGN to cancel the internal offset voltage of the ADC; Highly recommended for DC-measurements.	0x0

Bit	Mode	Symbol	Description	Reset
13	R/W	GP_ADC_SIGN	0: Default 1: Conversion with opposite sign at input and output to cancel out the internal offset of the ADC and low-frequency	0x0
12:8	R/W	GP_ADC_SEL	ADC input selection. If GP_ADC_SE = 1 (single ended mode): 0: GP ADC0 (P1_09) 1: GP ADC1 (P0_25) 2: GP ADC2 (P0_08) 3: GP ADC3 (P0_09) 4: VDD (internal) 5: V30 (GP_ADC_ATTN3X scaler automatically selected) 6: V30 (GP_ADC_ATTN3X scaler automatically selected) 7: Reserved 8: VBAT1 (5V to 1.2V scaler selected) 9: VSSA (analog ground) 10-15: Reserved 16: GP ADC4 (P1_13) 17: GP ADC5 (P1_12) 18: GP ADC6 (P1_18) 19: GP ADC7 (P1_19) 20: Diff Temperature sensor, See GP_ADC_DIFF_TEMP_SEL 21-31: Reserved If GP_ADC_SE = 0 (differential mode): 0: P1[09] vs P0[25] All other combinations are P0[08] vs P0[09].	0x0
7	R/W	GP_ADC_MUTE	0: Normal operation 1: Mute ADC input. Takes sample at mid-scale (to determine the internal offset and/or noise of the ADC with regards to VDD_REF which is also sampled by the ADC).	0x0
6	R/W	GP_ADC_SE	0: Differential mode 1: Single ended mode	0x0
5	R/W	GP_ADC_MINT	0: Disable (mask) GP_ADC_INT. 1: Enable GP_ADC_INT to ICU.	0x0
4	R	GP_ADC_INT	1: AD conversion ready and has generated an interrupt. Must be cleared by writing any value to GP_ADC_CLEAR_INT_REG.	0x0
3	R/W	GP_ADC_CLK_SEL	0: Internal high-speed ADC clock used (recommended). 1: Digital clock used (ADC_CLK).	0x0
2	R/W	GP_ADC_CONT	0: Manual ADC mode, a single result will be generated after setting the GP_ADC_START bit. 1: Continuous ADC mode, new ADC results will be constantly stored in GP_ADC_RESULT_REG. Still GP_ADC_START has to be set to start the execution. The time between conversions is configurable with GP_ADC_INTERVAL.	0x0

Bit	Mode	Symbol	Description	Reset
1	R/W	GP_ADC_START	0: ADC conversion ready. 1: If a 1 is written, the ADC starts a conversion. After the conversion this bit will be set to 0 and the GP_ADC_INT bit will be set. It is not allowed to write this bit while it is not (yet) zero.	0x0
0	R/W	GP_ADC_EN	0: LDO is off and ADC is disabled.. 1: LDO is turned on and afterwards the ADC is enabled.	0x0

Table 632: GP_ADC_CTRL2_REG (0x50030904)

Bit	Mode	Symbol	Description	Reset
15:12	R/W	GP_ADC_STORE_DE L	0: Data is stored after handshake synchronisation 1: Data is stored two ADC_CLK cycles after internal start trigger 15: Data is stored sixteen ADC_CLK cycles after internal start trigger	0x0
11:8	R/W	GP_ADC_SMPL_TIME	0: The sample time (switch is closed) is one ADC_CLK cycle 1: The sample time is 1*32 ADC_CLK cycles 2: The sample time is 2*32 ADC_CLK cycles 15: The sample time is 15*32 ADC_CLK cycles	0x0
7:5	R/W	GP_ADC_CONV_NRS	0: 1 sample is taken or 2 in case ADC_CHOP is active. 1: 2 samples are taken. 2: 4 samples are taken. 7: 128 samples are taken.	0x0
4	R/W	-	Reserved	0x0
3	R/W	GP_ADC_DMA_EN	0: DMA functionality disabled 1: DMA functionality enabled	0x0
2	R/W	GP_ADC_I20U	1: Adds 20uA constant load current at the ADC LDO to minimize ripple on the reference voltage of the ADC.	0x0
1	R/W	GP_ADC_IDYN	1: Enables dynamic load current at the ADC LDO to minimize ripple on the reference voltage of the ADC.	0x0
0	R/W	GP_ADC_ATTN3X	0: Input voltages up to 1.2V allowed. 1: Input voltages up to 3.6V allowed by enabling 3x attenuator. (if ADC_SEL=7 or 8, this bit is automatically set to 1) Enabling the attenuator requires a longer sampling time.	0x0

Table 633: GP_ADC_CTRL3_REG (0x50030908)

Bit	Mode	Symbol	Description	Reset
15:8	R/W	GP_ADC_INTERVAL	Defines the interval between two ADC conversions in case GP_ADC_CONT is set. 0: No extra delay between two conversions. 1: 1.024ms interval between two conversions. 2: 2.048ms interval between two conversions. 255: 261.12ms interval between two conversions.	0x0

Bit	Mode	Symbol	Description	Reset
7:0	R/W	GP_ADC_EN_DEL	Defines the delay for enabling the ADC after enabling the LDO. 0: Not allowed 1: 32x ADC_CLK period. n: n*32x ADC_CLK period.	0x40

Table 634: GP_ADC_OFFP_REG (0x5003090C)

Bit	Mode	Symbol	Description	Reset
9:0	R/W	GP_ADC_OFFP	Offset adjust of 'positive' array of ADC-network (effective if "GP_ADC_SE=0", or "GP_ADC_SE=1 AND GP_ADC_SIGN=0")	0x200

Table 635: GP_ADC_OFFN_REG (0x50030910)

Bit	Mode	Symbol	Description	Reset
9:0	R/W	GP_ADC_OFFN	Offset adjust of 'negative' array of ADC-network (effective if "GP_ADC_SE=0", or "GP_ADC_SE=1 AND GP_ADC_SIGN=1")	0x200

Table 636: GP_ADC_CLEAR_INT_REG (0x50030914)

Bit	Mode	Symbol	Description	Reset
15:0	R0/W	GP_ADC_CLR_INT	Writing any value to this register will clear the ADC_INT interrupt. Reading returns 0.	0x0

Table 637: GP_ADC_RESULT_REG (0x50030918)

Bit	Mode	Symbol	Description	Reset
15:0	R	GP_ADC_VAL	Returns the 10 up to 16 bits linear value of the last AD conversion. The upper 10 bits are always valid, the lower 6 bits are only valid in case oversampling has been applied. Two samples results in one extra bit and 64 samples results in six extra bits.	0x0

42.22 General Purpose I/O Registers

Table 638: Register map GPIO

Address	Register	Description
0x50020A00	P0_DATA_REG	P0 Data input / output Register
0x50020A04	P1_DATA_REG	P1 Data input / output Register
0x50020A08	P0_SET_DATA_REG	P0 Set port pins Register
0x50020A0C	P1_SET_DATA_REG	P1 Set port pins Register
0x50020A10	P0_RESET_DATA_REG	P0 Reset port pins Register
0x50020A14	P1_RESET_DATA_REG	P1 Reset port pins Register
0x50020A18	P0_00_MODE_REG	P0_00 Mode Register

Multi-Core Bluetooth 5.2 SoC Family with System PMU

Address	Register	Description
0x50020A1C	P0_01_MODE_REG	P0_01 Mode Register
0x50020A20	P0_02_MODE_REG	P0_02 Mode Register
0x50020A24	P0_03_MODE_REG	P0_03 Mode Register
0x50020A28	P0_04_MODE_REG	P0_04 Mode Register
0x50020A2C	P0_05_MODE_REG	P0_05 Mode Register
0x50020A30	P0_06_MODE_REG	P0_06 Mode Register
0x50020A34	P0_07_MODE_REG	P0_07 Mode Register
0x50020A38	P0_08_MODE_REG	P0_08 Mode Register
0x50020A3C	P0_09_MODE_REG	P0_09 Mode Register
0x50020A40	P0_10_MODE_REG	P0_10 Mode Register
0x50020A44	P0_11_MODE_REG	P0_11 Mode Register
0x50020A48	P0_12_MODE_REG	P0_12 Mode Register
0x50020A4C	P0_13_MODE_REG	P0_13 Mode Register
0x50020A50	P0_14_MODE_REG	P0_14 Mode Register
0x50020A54	P0_15_MODE_REG	P0_15 Mode Register
0x50020A58	P0_16_MODE_REG	P0_16 Mode Register
0x50020A5C	P0_17_MODE_REG	P0_17 Mode Register
0x50020A60	P0_18_MODE_REG	P0_18 Mode Register
0x50020A64	P0_19_MODE_REG	P0_19 Mode Register
0x50020A68	P0_20_MODE_REG	P0_20 Mode Register
0x50020A6C	P0_21_MODE_REG	P0_21 Mode Register
0x50020A70	P0_22_MODE_REG	P0_22 Mode Register
0x50020A74	P0_23_MODE_REG	P0_23 Mode Register
0x50020A78	P0_24_MODE_REG	P0_24 Mode Register
0x50020A7C	P0_25_MODE_REG	P0_25 Mode Register
0x50020A80	P0_26_MODE_REG	P0_26 Mode Register
0x50020A84	P0_27_MODE_REG	P0_27 Mode Register
0x50020A88	P0_28_MODE_REG	P0_28 Mode Register
0x50020A8C	P0_29_MODE_REG	P0_29 Mode Register
0x50020A90	P0_30_MODE_REG	P0_30 Mode Register
0x50020A94	P0_31_MODE_REG	P0_31 Mode Register
0x50020A98	P1_00_MODE_REG	P1_00 Mode Register
0x50020A9C	P1_01_MODE_REG	P1_01 Mode Register
0x50020AA0	P1_02_MODE_REG	P1_02 Mode Register
0x50020AA4	P1_03_MODE_REG	P1_03 Mode Register
0x50020AA8	P1_04_MODE_REG	P1_04 Mode Register
0x50020AAC	P1_05_MODE_REG	P1_05 Mode Register
0x50020AB0	P1_06_MODE_REG	P1_06 Mode Register
0x50020AB4	P1_07_MODE_REG	P1_07 Mode Register
0x50020AB8	P1_08_MODE_REG	P1_08 Mode Register
0x50020ABC	P1_09_MODE_REG	P1_09 Mode Register

Address	Register	Description
0x50020AC0	P1_10_MODE_REG	P1_10 Mode Register
0x50020AC4	P1_11_MODE_REG	P1_11 Mode Register
0x50020AC8	P1_12_MODE_REG	P1_12 Mode Register
0x50020ACC	P1_13_MODE_REG	P1_13 Mode Register
0x50020AD0	P1_14_MODE_REG	P1_14 Mode Register
0x50020AD4	P1_15_MODE_REG	P1_15 Mode Register
0x50020AD8	P1_16_MODE_REG	P1_16 Mode Register
0x50020ADC	P1_17_MODE_REG	P1_17 Mode Register
0x50020AE0	P1_18_MODE_REG	P1_18 Mode Register
0x50020AE4	P1_19_MODE_REG	P1_19 Mode Register
0x50020AE8	P1_20_MODE_REG	P1_20 Mode Register
0x50020AEC	P1_21_MODE_REG	P1_21 Mode Register
0x50020AF0	P1_22_MODE_REG	P1_22 Mode Register
0x50020AF4	P0_PADPWR_CTRL_REG	P0 Output Power Control Register
0x50020AF8	P1_PADPWR_CTRL_REG	P1 Output Power Control Register
0x50020AFC	GPIO_CLK_SEL_REG	Select which clock to map on ports P0/P1
0x50020B00	PAD_WEAK_CTRL_REG	Weak Pads Control Register

Table 639: P0_DATA_REG (0x50020A00)

Bit	Mode	Symbol	Description	Reset
31:0	R/W	P0_DATA	Set P0 output register when written; Returns the value of P0 port when read	0x1410

Table 640: P1_DATA_REG (0x50020A04)

Bit	Mode	Symbol	Description	Reset
22:0	R/W	P1_DATA	Set P1 output register when written; Returns the value of P1 port when read	0x0

Table 641: P0_SET_DATA_REG (0x50020A08)

Bit	Mode	Symbol	Description	Reset
31:0	R0/W	P0_SET	Writing a 1 to P0[y] sets P0[y] to 1. Writing 0 is discarded; Reading returns 0	0x0

Table 642: P1_SET_DATA_REG (0x50020A0C)

Bit	Mode	Symbol	Description	Reset
22:0	R0/W	P1_SET	Writing a 1 to P1[y] sets P1[y] to 1. Writing 0 is discarded; Reading returns 0	0x0

Table 643: **P0_RESET_DATA_REG (0x50020A10)**

Bit	Mode	Symbol	Description	Reset
31:0	R0/W	P0_RESET	Writing a 1 to P0[y] sets P0[y] to 0. Writing 0 is discarded; Reading returns 0	0x0

Table 644: **P1_RESET_DATA_REG (0x50020A14)**

Bit	Mode	Symbol	Description	Reset
22:0	R0/W	P1_RESET	Writing a 1 to P1[y] sets P1[y] to 0. Writing 0 is discarded; Reading returns 0	0x0

Table 645: **P0_00_MODE_REG (0x50020A18)**

Bit	Mode	Symbol	Description	Reset
10	R/W	PPOD	0: Push pull 1: Open drain	0x0
9:8	R/W	PUPD	00 = Input, no resistors selected 01 = Input, pull-up selected 10 = Input, pull-down selected 11 = Output, no resistors selected In ADC mode, these bits are don't care	0x2
7:6	R	-	Reserved	0x0
5:0	R/W	PID	Function of port: 0: GPIO (see also the PUPD bit-field) 1: UART_RX 2: UART_TX 3: UART2_RX 4: UART2_TX 5: UART2_CTSN 6: UART2_RTSN 7: UART3_RX 8: UART3_TX 9: UART3_CTSN 10: UART3_RTSN 11: ISO_CLK 12: ISO_DATA 13: SPI_DI 14: SPI_DO 15: SPI_CLK 16: SPI_EN 17: SPI2_DI 18: SPI2_DO 19: SPI2_CLK 20: SPI2_EN 21: I2C_SCL 22: I2C_SDA 23: I2C2_SCL 24: I2C2_SDA 25: USB_SOF	0x0

Bit	Mode	Symbol	Description	Reset
			26: ADC (dedicated pins, see also the "Input/Output Ports" chapter of Datasheet) 27: USB (dedicated pins P0_14 and P0_15) 28: PCM_DI 29: PCM_DO 30: PCM_FSC 31: PCM_CLK 32: PDM_DATA 33: PDM_CLK 34: COEX_EXT_ACT 35: COEX_SMART_ACT 36: COEX_SMART_PRI 37: PORT0_DCF 38: PORT1_DCF 39: PORT2_DCF 40: PORT3_DCF 41: PORT4_DCF 42: CLOCK (see also GPIO_CLK_SEL_REG for the dedicated pins mapping of supported clocks) 43: PG (dedicated pins, see also the "Input/Output Ports" chapter of Datasheet) 44: LCD (dedicated pins see also the "Input/Output Ports" chapter of Datasheet) 45: LCD_SPI_DC 46: LCD_SPI_DO 47: LCD_SPI_CLK 48: LCD_SPI_EN 49: TIM_PWM 50: TIM2_PWM 51: TIM_1SHOT 52: TIM2_1SHOT 53: TIM3_PWM 54: TIM4_PWM 55: Reserved 56: CMAC_DIAG0 57: CMAC_DIAG1 58: CMAC_DIAG2 59: CMAC_DIAGX (dedicated pins, see also the "Input/Output Ports" chapter of Datasheet) 60: Reserved 61: Reserved 62: Reserved 63: Reserved	

Table 646: **P0_01_MODE_REG** (0x50020A1C)

Bit	Mode	Symbol	Description	Reset
10	R/W	PPOD	0: Push pull	0x0

Bit	Mode	Symbol	Description	Reset
			1: Open drain	
9:8	R/W	PUPD	00 = Input, no resistors selected 01 = Input, pull-up selected 10 = Input, pull-down selected 11 = Output, no resistors selected In ADC mode, these bits are don't care	0x2
7:6	R	-	Reserved	0x0
5:0	R/W	PID	See P0_00_MODE_REG[PID]	0x0

Table 647: P0_02_MODE_REG (0x50020A20)

Bit	Mode	Symbol	Description	Reset
10	R/W	PPOD	0: Push pull 1: Open drain	0x0
9:8	R/W	PUPD	00 = Input, no resistors selected 01 = Input, pull-up selected 10 = Input, pull-down selected 11 = Output, no resistors selected In ADC mode, these bits are don't care	0x2
7:6	R	-	Reserved	0x0
5:0	R/W	PID	See P0_00_MODE_REG[PID]	0x0

Table 648: P0_03_MODE_REG (0x50020A24)

Bit	Mode	Symbol	Description	Reset
10	R/W	PPOD	0: Push pull 1: Open drain	0x0
9:8	R/W	PUPD	00 = Input, no resistors selected 01 = Input, pull-up selected 10 = Input, pull-down selected 11 = Output, no resistors selected In ADC mode, these bits are don't care	0x2
7:6	R	-	Reserved	0x0
5:0	R/W	PID	See P0_00_MODE_REG[PID]	0x0

Table 649: P0_04_MODE_REG (0x50020A28)

Bit	Mode	Symbol	Description	Reset
10	R/W	PPOD	0: Push pull 1: Open drain	0x0
9:8	R/W	PUPD	00 = Input, no resistors selected 01 = Input, pull-up selected 10 = Input, pull-down selected 11 = Output, no resistors selected In ADC mode, these bits are don't care	0x1
7:6	R	-	Reserved	0x0
5:0	R/W	PID	See P0_00_MODE_REG[PID]	0x0

Table 650: P0_05_MODE_REG (0x50020A2C)

Bit	Mode	Symbol	Description	Reset
10	R/W	PPOD	0: Push pull 1: Open drain	0x0
9:8	R/W	PUPD	00 = Input, no resistors selected 01 = Input, pull-up selected 10 = Input, pull-down selected 11 = Output, no resistors selected In ADC mode, these bits are don't care	0x2
7:6	R	-	Reserved	0x0
5:0	R/W	PID	See P0_00_MODE_REG[PID]	0x0

Table 651: P0_06_MODE_REG (0x50020A30)

Bit	Mode	Symbol	Description	Reset
10	R/W	PPOD	0: Push pull 1: Open drain	0x0
9:8	R/W	PUPD	00 = Input, no resistors selected 01 = Input, pull-up selected 10 = Input, pull-down selected 11 = Output, no resistors selected In ADC mode, these bits are don't care	0x2
7:6	R	-	Reserved	0x0
5:0	R/W	PID	See P0_00_MODE_REG[PID]	0x0

Table 652: P0_07_MODE_REG (0x50020A34)

Bit	Mode	Symbol	Description	Reset
10	R/W	PPOD	0: Push pull 1: Open drain	0x0
9:8	R/W	PUPD	00 = Input, no resistors selected 01 = Input, pull-up selected 10 = Input, pull-down selected 11 = Output, no resistors selected In ADC mode, these bits are don't care.	0x2
7:6	R	-	Reserved	0x0
5:0	R/W	PID	See P0_00_MODE_REG[PID]	0x0

Table 653: P0_08_MODE_REG (0x50020A38)

Bit	Mode	Symbol	Description	Reset
10	R/W	PPOD	0: Push pull 1: Open drain	0x0
9:8	R/W	PUPD	00 = Input, no resistors selected 01 = Input, pull-up selected 10 = Input, pull-down selected 11 = Output, no resistors selected In ADC mode, these bits are don't care.	0x2

Bit	Mode	Symbol	Description	Reset
7:6	R	-	Reserved	0x0
5:0	R/W	PID	See P0_00_MODE_REG[PID]	0x0

Table 654: P0_09_MODE_REG (0x50020A3C)

Bit	Mode	Symbol	Description	Reset
10	R/W	PPOD	0: Push pull 1: Open drain	0x0
9:8	R/W	PUPD	00 = Input, no resistors selected 01 = Input, pull-up selected 10 = Input, pull-down selected 11 = Output, no resistors selected In ADC mode, these bits are don't care.	0x2
7:6	R	-	Reserved	0x0
5:0	R/W	PID	See P0_00_MODE_REG[PID]	0x0

Table 655: P0_10_MODE_REG (0x50020A40)

Bit	Mode	Symbol	Description	Reset
10	R/W	PPOD	0: Push pull 1: Open drain	0x0
9:8	R/W	PUPD	00 = Input, no resistors selected 01 = Input, pull-up selected 10 = Input, pull-down selected 11 = Output, no resistors selected In ADC mode, these bits are don't care.	0x1
7:6	R	-	Reserved	0x0
5:0	R/W	PID	See P0_00_MODE_REG[PID]	0x0

Table 656: P0_11_MODE_REG (0x50020A44)

Bit	Mode	Symbol	Description	Reset
10	R/W	PPOD	0: Push pull 1: Open drain	0x0
9:8	R/W	PUPD	00 = Input, no resistors selected 01 = Input, pull-up selected 10 = Input, pull-down selected 11 = Output, no resistors selected In ADC mode, these bits are don't care.	0x2
7:6	R	-	Reserved	0x0
5:0	R/W	PID	See P0_00_MODE_REG[PID]	0x0

Table 657: **P0_12_MODE_REG** (0x50020A48)

Bit	Mode	Symbol	Description	Reset
10	R/W	PPOD	0: Push pull 1: Open drain	0x0
9:8	R/W	PUPD	00 = Input, no resistors selected 01 = Input, pull-up selected 10 = Input, pull-down selected 11 = Output, no resistors selected In ADC mode, these bits are don't care.	0x1
7:6	R	-	Reserved	0x0
5:0	R/W	PID	See P0_00_MODE_REG[PID]	0x0

Table 658: **P0_13_MODE_REG** (0x50020A4C)

Bit	Mode	Symbol	Description	Reset
10	R/W	PPOD	0: Push pull 1: Open drain	0x0
9:8	R/W	PUPD	00 = Input, no resistors selected 01 = Input, pull-up selected 10 = Input, pull-down selected 11 = Output, no resistors selected In ADC mode, these bits are don't care.	0x2
7:6	R	-	Reserved	0x0
5:0	R/W	PID	See P0_00_MODE_REG[PID]	0x0

Table 659: **P0_14_MODE_REG** (0x50020A50)

Bit	Mode	Symbol	Description	Reset
10	R/W	PPOD	0: Push pull 1: Open drain	0x0
9:8	R/W	PUPD	00 = Input, no resistors selected 01 = Input, pull-up selected 10 = Input, pull-down selected 11 = Output, no resistors selected In ADC mode, these bits are don't care.	0x2
7:6	R	-	Reserved	0x0
5:0	R/W	PID	See P0_00_MODE_REG[PID]	0x0

Table 660: **P0_15_MODE_REG** (0x50020A54)

Bit	Mode	Symbol	Description	Reset
10	R/W	PPOD	0: Push pull 1: Open drain	0x0
9:8	R/W	PUPD	00 = Input, no resistors selected 01 = Input, pull-up selected 10 = Input, pull-down selected	0x2

Bit	Mode	Symbol	Description	Reset
			11 = Output, no resistors selected In ADC mode, these bits are don't care.	
7:6	R	-	Reserved	0x0
5:0	R/W	PID	See P0_00_MODE_REG[PID]	0x0

Table 661: P0_16_MODE_REG (0x50020A58)

Bit	Mode	Symbol	Description	Reset
10	R/W	PPOD	0: Push pull 1: Open drain	0x0
9:8	R/W	PUPD	00 = Input, no resistors selected 01 = Input, pull-up selected 10 = Input, pull-down selected 11 = Output, no resistors selected In ADC mode, these bits are don't care.	0x2
7:6	R	-	Reserved	0x0
5:0	R/W	PID	See P0_00_MODE_REG[PID]	0x0

Table 662: P0_17_MODE_REG (0x50020A5C)

Bit	Mode	Symbol	Description	Reset
10	R/W	PPOD	0: Push pull 1: Open drain	0x0
9:8	R/W	PUPD	00 = Input, no resistors selected 01 = Input, pull-up selected 10 = Input, pull-down selected 11 = Output, no resistors selected In ADC mode, these bits are don't care.	0x2
7:6	R	-	Reserved	0x0
5:0	R/W	PID	See P0_00_MODE_REG[PID]	0x0

Table 663: P0_18_MODE_REG (0x50020A60)

Bit	Mode	Symbol	Description	Reset
10	R/W	PPOD	0: Push pull 1: Open drain	0x0
9:8	R/W	PUPD	00 = Input, no resistors selected 01 = Input, pull-up selected 10 = Input, pull-down selected 11 = Output, no resistors selected In ADC mode, these bits are don't care.	0x2
7:6	R	-	Reserved	0x0
5:0	R/W	PID	See P0_00_MODE_REG[PID]	0x0

Table 664: **P0_19_MODE_REG** (0x50020A64)

Bit	Mode	Symbol	Description	Reset
10	R/W	PPOD	0: Push pull 1: Open drain	0x0
9:8	R/W	PUPD	00 = Input, no resistors selected 01 = Input, pull-up selected 10 = Input, pull-down selected 11 = Output, no resistors selected In ADC mode, these bits are don't care.	0x2
7:6	R	-	Reserved	0x0
5:0	R/W	PID	See P0_00_MODE_REG[PID]	0x0

Table 665: **P0_20_MODE_REG** (0x50020A68)

Bit	Mode	Symbol	Description	Reset
10	R/W	PPOD	0: Push pull 1: Open drain	0x0
9:8	R/W	PUPD	00 = Input, no resistors selected 01 = Input, pull-up selected 10 = Input, pull-down selected 11 = Output, no resistors selected In ADC mode, these bits are don't care.	0x2
7:6	R	-	Reserved	0x0
5:0	R/W	PID	See P0_00_MODE_REG[PID]	0x0

Table 666: **P0_21_MODE_REG** (0x50020A6C)

Bit	Mode	Symbol	Description	Reset
10	R/W	PPOD	0: Push pull 1: Open drain	0x0
9:8	R/W	PUPD	00 = Input, no resistors selected 01 = Input, pull-up selected 10 = Input, pull-down selected 11 = Output, no resistors selected In ADC mode, these bits are don't care.	0x2
7:6	R	-	Reserved	0x0
5:0	R/W	PID	See P0_00_MODE_REG[PID]	0x0

Table 667: **P0_22_MODE_REG** (0x50020A70)

Bit	Mode	Symbol	Description	Reset
10	R/W	PPOD	0: Push pull 1: Open drain	0x0
9:8	R/W	PUPD	00 = Input, no resistors selected 01 = Input, pull-up selected 10 = Input, pull-down selected	0x2

Bit	Mode	Symbol	Description	Reset
			11 = Output, no resistors selected In ADC mode, these bits are don't care.	
7:6	R	-	Reserved	0x0
5:0	R/W	PID	See P0_00_MODE_REG[PID]	0x0

Table 668: P0_23_MODE_REG (0x50020A74)

Bit	Mode	Symbol	Description	Reset
10	R/W	PPOD	0: Push pull 1: Open drain	0x0
9:8	R/W	PUPD	00 = Input, no resistors selected 01 = Input, pull-up selected 10 = Input, pull-down selected 11 = Output, no resistors selected In ADC mode, these bits are don't care.	0x2
7:6	R	-	Reserved	0x0
5:0	R/W	PID	See P0_00_MODE_REG[PID]	0x0

Table 669: P0_24_MODE_REG (0x50020A78)

Bit	Mode	Symbol	Description	Reset
10	R/W	PPOD	0: Push pull 1: Open drain	0x0
9:8	R/W	PUPD	00 = Input, no resistors selected 01 = Input, pull-up selected 10 = Input, pull-down selected 11 = Output, no resistors selected In ADC mode, these bits are don't care.	0x2
7:6	R	-	Reserved	0x0
5:0	R/W	PID	See P0_00_MODE_REG[PID]	0x0

Table 670: P0_25_MODE_REG (0x50020A7C)

Bit	Mode	Symbol	Description	Reset
10	R/W	PPOD	0: Push pull 1: Open drain	0x0
9:8	R/W	PUPD	00 = Input, no resistors selected 01 = Input, pull-up selected 10 = Input, pull-down selected 11 = Output, no resistors selected In ADC mode, these bits are don't care.	0x2
7:6	R	-	Reserved	0x0
5:0	R/W	PID	See P0_00_MODE_REG[PID]	0x0

Table 671: **P0_26_MODE_REG** (0x50020A80)

Bit	Mode	Symbol	Description	Reset
10	R/W	PPOD	0: Push pull 1: Open drain	0x0
9:8	R/W	PUPD	00 = Input, no resistors selected 01 = Input, pull-up selected 10 = Input, pull-down selected 11 = Output, no resistors selected In ADC mode, these bits are don't care.	0x2
7:6	R	-	Reserved	0x0
5:0	R/W	PID	See P0_00_MODE_REG[PID]	0x0

Table 672: **P0_27_MODE_REG** (0x50020A84)

Bit	Mode	Symbol	Description	Reset
10	R/W	PPOD	0: Push pull 1: Open drain	0x0
9:8	R/W	PUPD	00 = Input, no resistors selected 01 = Input, pull-up selected 10 = Input, pull-down selected 11 = Output, no resistors selected In ADC mode, these bits are don't care.	0x2
7:6	R	-	Reserved	0x0
5:0	R/W	PID	See P0_00_MODE_REG[PID]	0x0

Table 673: **P0_28_MODE_REG** (0x50020A88)

Bit	Mode	Symbol	Description	Reset
10	R/W	PPOD	0: Push pull 1: Open drain	0x0
9:8	R/W	PUPD	00 = Input, no resistors selected 01 = Input, pull-up selected 10 = Input, pull-down selected 11 = Output, no resistors selected In ADC mode, these bits are don't care.	0x2
7:6	R	-	Reserved	0x0
5:0	R/W	PID	See P0_00_MODE_REG[PID]	0x0

Table 674: **P0_29_MODE_REG** (0x50020A8C)

Bit	Mode	Symbol	Description	Reset
10	R/W	PPOD	0: Push pull 1: Open drain	0x0
9:8	R/W	PUPD	00 = Input, no resistors selected 01 = Input, pull-up selected 10 = Input, pull-down selected	0x2

Bit	Mode	Symbol	Description	Reset
			11 = Output, no resistors selected In ADC mode, these bits are don't care.	
7:6	R	-	Reserved	0x0
5:0	R/W	PID	See P0_00_MODE_REG[PID]	0x0

Table 675: P0_30_MODE_REG (0x50020A90)

Bit	Mode	Symbol	Description	Reset
10	R/W	PPOD	0: Push pull 1: Open drain	0x0
9:8	R/W	PUPD	00 = Input, no resistors selected 01 = Input, pull-up selected 10 = Input, pull-down selected 11 = Output, no resistors selected In ADC mode, these bits are don't care.	0x2
7:6	R	-	Reserved	0x0
5:0	R/W	PID	See P0_00_MODE_REG[PID]	0x0

Table 676: P0_31_MODE_REG (0x50020A94)

Bit	Mode	Symbol	Description	Reset
10	R/W	PPOD	0: Push pull 1: Open drain	0x0
9:8	R/W	PUPD	00 = Input, no resistors selected 01 = Input, pull-up selected 10 = Input, pull-down selected 11 = Output, no resistors selected In ADC mode, these bits are don't care.	0x2
7:6	R	-	Reserved	0x0
5:0	R/W	PID	See P0_00_MODE_REG[PID]	0x0

Table 677: P1_00_MODE_REG (0x50020A98)

Bit	Mode	Symbol	Description	Reset
10	R/W	PPOD	0: Push pull 1: Open drain	0x0
9:8	R/W	PUPD	00 = Input, no resistors selected 01 = Input, pull-up selected 10 = Input, pull-down selected 11 = Output, no resistors selected In ADC mode, these bits are don't care	0x2
7:6	R	-	Reserved	0x0
5:0	R/W	PID	See P0_00_MODE_REG[PID]	0x0

Table 678: P1_01_MODE_REG (0x50020A9C)

Bit	Mode	Symbol	Description	Reset
10	R/W	PPOD	0: Push pull 1: Open drain	0x0
9:8	R/W	PUPD	00 = Input, no resistors selected 01 = Input, pull-up selected 10 = Input, pull-down selected 11 = Output, no resistors selected In ADC mode, these bits are don't care	0x2
7:6	R	-	Reserved	0x0
5:0	R/W	PID	See P0_00_MODE_REG[PID]	0x0

Table 679: P1_02_MODE_REG (0x50020AA0)

Bit	Mode	Symbol	Description	Reset
10	R/W	PPOD	0: Push pull 1: Open drain	0x0
9:8	R/W	PUPD	00 = Input, no resistors selected 01 = Input, pull-up selected 10 = Input, pull-down selected 11 = Output, no resistors selected In ADC mode, these bits are don't care	0x2
7:6	R	-	Reserved	0x0
5:0	R/W	PID	See P0_00_MODE_REG[PID]	0x0

Table 680: P1_03_MODE_REG (0x50020AA4)

Bit	Mode	Symbol	Description	Reset
10	R/W	PPOD	0: Push pull 1: Open drain	0x0
9:8	R/W	PUPD	00 = Input, no resistors selected 01 = Input, pull-up selected 10 = Input, pull-down selected 11 = Output, no resistors selected In ADC mode, these bits are don't care	0x2
7:6	R	-	Reserved	0x0
5:0	R/W	PID	See P0_00_MODE_REG[PID]	0x0

Table 681: P1_04_MODE_REG (0x50020AA8)

Bit	Mode	Symbol	Description	Reset
10	R/W	PPOD	0: Push pull 1: Open drain	0x0
9:8	R/W	PUPD	00 = Input, no resistors selected 01 = Input, pull-up selected 10 = Input, pull-down selected 11 = Output, no resistors selected In ADC mode, these bits are don't care	0x2
7:6	R	-	Reserved	0x0

Bit	Mode	Symbol	Description	Reset
5:0	R/W	PID	See P0_00_MODE_REG[PID]	0x0

Table 682: P1_05_MODE_REG (0x50020AAC)

Bit	Mode	Symbol	Description	Reset
10	R/W	PPOD	0: Push pull 1: Open drain	0x0
9:8	R/W	PUPD	00 = Input, no resistors selected 01 = Input, pull-up selected 10 = Input, pull-down selected 11 = Output, no resistors selected In ADC mode, these bits are don't care	0x2
7:6	R	-	Reserved	0x0
5:0	R/W	PID	See P0_00_MODE_REG[PID]	0x0

Table 683: P1_06_MODE_REG (0x50020AB0)

Bit	Mode	Symbol	Description	Reset
10	R/W	PPOD	0: Push pull 1: Open drain	0x0
9:8	R/W	PUPD	00 = Input, no resistors selected 01 = Input, pull-up selected 10 = Input, pull-down selected 11 = Output, no resistors selected In ADC mode, these bits are don't care	0x2
7:6	R	-	Reserved	0x0
5:0	R/W	PID	See P0_00_MODE_REG[PID]	0x0

Table 684: P1_07_MODE_REG (0x50020AB4)

Bit	Mode	Symbol	Description	Reset
10	R/W	PPOD	0: Push pull 1: Open drain	0x0
9:8	R/W	PUPD	00 = Input, no resistors selected 01 = Input, pull-up selected 10 = Input, pull-down selected 11 = Output, no resistors selected In ADC mode, these bits are don't care	0x2
7:6	R	-	Reserved	0x0
5:0	R/W	PID	See P0_00_MODE_REG[PID]	0x0

Table 685: P1_08_MODE_REG (0x50020AB8)

Bit	Mode	Symbol	Description	Reset
10	R/W	PPOD	0: Push pull 1: Open drain	0x0
9:8	R/W	PUPD	00 = Input, no resistors selected	0x2

Bit	Mode	Symbol	Description	Reset
			01 = Input, pull-up selected 10 = Input, pull-down selected 11 = Output, no resistors selected In ADC mode, these bits are don't care.	
7:6	R	-	Reserved	0x0
5:0	R/W	PID	See P0_00_MODE_REG[PID]	0x0

Table 686: P1_09_MODE_REG (0x50020ABC)

Bit	Mode	Symbol	Description	Reset
10	R/W	PPOD	0: Push pull 1: Open drain	0x0
9:8	R/W	PUPD	00 = Input, no resistors selected 01 = Input, pull-up selected 10 = Input, pull-down selected 11 = Output, no resistors selected In ADC mode, these bits are don't care.	0x2
7:6	R	-	Reserved	0x0
5:0	R/W	PID	See P0_00_MODE_REG[PID]	0x0

Table 687: P1_10_MODE_REG (0x50020AC0)

Bit	Mode	Symbol	Description	Reset
10	R/W	PPOD	0: Push pull 1: Open drain	0x0
9:8	R/W	PUPD	00 = Input, no resistors selected 01 = Input, pull-up selected 10 = Input, pull-down selected 11 = Output, no resistors selected In ADC mode, these bits are don't care.	0x2
7:6	R	-	Reserved	0x0
5:0	R/W	PID	See P0_00_MODE_REG[PID]	0x0

Table 688: P1_11_MODE_REG (0x50020AC4)

Bit	Mode	Symbol	Description	Reset
10	R/W	PPOD	0: Push pull 1: Open drain	0x0
9:8	R/W	PUPD	00 = Input, no resistors selected 01 = Input, pull-up selected 10 = Input, pull-down selected 11 = Output, no resistors selected In ADC mode, these bits are don't care.	0x2
7:6	R	-	Reserved	0x0
5:0	R/W	PID	See P0_00_MODE_REG[PID]	0x0

Table 689: P1_12_MODE_REG (0x50020AC8)

Bit	Mode	Symbol	Description	Reset
10	R/W	PPOD	0: Push pull 1: Open drain	0x0
9:8	R/W	PUPD	00 = Input, no resistors selected 01 = Input, pull-up selected 10 = Input, pull-down selected 11 = Output, no resistors selected In ADC mode, these bits are don't care.	0x2
7:6	R	-	Reserved	0x0
5:0	R/W	PID	See P0_00_MODE_REG[PID]	0x0

Table 690: P1_13_MODE_REG (0x50020ACC)

Bit	Mode	Symbol	Description	Reset
10	R/W	PPOD	0: Push pull 1: Open drain	0x0
9:8	R/W	PUPD	00 = Input, no resistors selected 01 = Input, pull-up selected 10 = Input, pull-down selected 11 = Output, no resistors selected In ADC mode, these bits are don't care.	0x2
7:6	R	-	Reserved	0x0
5:0	R/W	PID	See P0_00_MODE_REG[PID]	0x0

Table 691: P1_14_MODE_REG (0x50020AD0)

Bit	Mode	Symbol	Description	Reset
10	R/W	PPOD	0: Push pull 1: Open drain	0x0
9:8	R/W	PUPD	00 = Input, no resistors selected 01 = Input, pull-up selected 10 = Input, pull-down selected 11 = Output, no resistors selected In ADC mode, these bits are don't care.	0x2
7:6	R	-	Reserved	0x0
5:0	R/W	PID	See P0_00_MODE_REG[PID]	0x0

Table 692: P1_15_MODE_REG (0x50020AD4)

Bit	Mode	Symbol	Description	Reset
10	R/W	PPOD	0: Push pull 1: Open drain	0x0
9:8	R/W	PUPD	00 = Input, no resistors selected 01 = Input, pull-up selected	0x2

Bit	Mode	Symbol	Description	Reset
			10 = Input, pull-down selected 11 = Output, no resistors selected In ADC mode, these bits are don't care.	
7:6	R	-	Reserved	0x0
5:0	R/W	PID	See P0_00_MODE_REG[PID]	0x0

Table 693: P1_16_MODE_REG (0x50020AD8)

Bit	Mode	Symbol	Description	Reset
10	R/W	PPOD	0: Push pull 1: Open drain	0x0
9:8	R/W	PUPD	00 = Input, no resistors selected 01 = Input, pull-up selected 10 = Input, pull-down selected 11 = Output, no resistors selected In ADC mode, these bits are don't care.	0x2
7:6	R	-	Reserved	0x0
5:0	R/W	PID	See P0_00_MODE_REG[PID]	0x0

Table 694: P1_17_MODE_REG (0x50020ADC)

Bit	Mode	Symbol	Description	Reset
10	R/W	PPOD	0: Push pull 1: Open drain	0x0
9:8	R/W	PUPD	00 = Input, no resistors selected 01 = Input, pull-up selected 10 = Input, pull-down selected 11 = Output, no resistors selected In ADC mode, these bits are don't care.	0x2
7:6	R	-	Reserved	0x0
5:0	R/W	PID	See P0_00_MODE_REG[PID]	0x0

Table 695: P1_18_MODE_REG (0x50020AE0)

Bit	Mode	Symbol	Description	Reset
10	R/W	PPOD	0: Push pull 1: Open drain	0x0
9:8	R/W	PUPD	00 = Input, no resistors selected 01 = Input, pull-up selected 10 = Input, pull-down selected 11 = Output, no resistors selected In ADC mode, these bits are don't care.	0x2
7:6	R	-	Reserved	0x0
5:0	R/W	PID	See P0_00_MODE_REG[PID]	0x0

Table 696: P1_19_MODE_REG (0x50020AE4)

Bit	Mode	Symbol	Description	Reset
10	R/W	PPOD	0: Push pull 1: Open drain	0x0
9:8	R/W	PUPD	00 = Input, no resistors selected 01 = Input, pull-up selected 10 = Input, pull-down selected 11 = Output, no resistors selected In ADC mode, these bits are don't care.	0x2
7:6	R	-	Reserved	0x0
5:0	R/W	PID	See P0_00_MODE_REG[PID]	0x0

Table 697: P1_20_MODE_REG (0x50020AE8)

Bit	Mode	Symbol	Description	Reset
10	R/W	PPOD	0: Push pull 1: Open drain	0x0
9:8	R/W	PUPD	00 = Input, no resistors selected 01 = Input, pull-up selected 10 = Input, pull-down selected 11 = Output, no resistors selected In ADC mode, these bits are don't care.	0x2
7:6	R	-	Reserved	0x0
5:0	R/W	PID	See P0_00_MODE_REG[PID]	0x0

Table 698: P1_21_MODE_REG (0x50020AEC)

Bit	Mode	Symbol	Description	Reset
10	R/W	PPOD	0: Push pull 1: Open drain	0x0
9:8	R/W	PUPD	00 = Input, no resistors selected 01 = Input, pull-up selected 10 = Input, pull-down selected 11 = Output, no resistors selected In ADC mode, these bits are don't care.	0x2
7:6	R	-	Reserved	0x0
5:0	R/W	PID	See P0_00_MODE_REG[PID]	0x0

Table 699: P1_22_MODE_REG (0x50020AF0)

Bit	Mode	Symbol	Description	Reset
10	R/W	PPOD	0: Push pull 1: Open drain	0x0
9:8	R/W	PUPD	00 = Input, no resistors selected 01 = Input, pull-up selected 10 = Input, pull-down selected	0x2

Bit	Mode	Symbol	Description	Reset
			11 = Output, no resistors selected In ADC mode, these bits are don't care.	
7:6	R	-	Reserved	0x0
5:0	R/W	PID	See P0_00_MODE_REG[PID]	0x0

Table 700: P0_PADPWR_CTRL_REG (0x50020AF4)

Bit	Mode	Symbol	Description	Reset
31:6	R/W	P0_OUT_CTRL	0 = P0_x port output is powered by the V30 rail (default) 1 = P0_x port output is powered by the 1V8P rail bit x controls the power supply of P0[x]	0x0
5:0	R/W	RESERVED_P0_OUT_CTRL	Reserved bits: P0_05 down to P0_00 are always supplied by V18P. So these bits don't control anything	0x0

Table 701: P1_PADPWR_CTRL_REG (0x50020AF8)

Bit	Mode	Symbol	Description	Reset
22:0	R/W	P1_OUT_CTRL	0 = P1_x port output is powered by the V30 rail (default) 1 = P1_x port output is powered by the 1V8P rail bit x controls the power supply of P1[x]	0x0

Table 702: GPIO_CLK_SEL_REG (0x50020AFC)

Bit	Mode	Symbol	Description	Reset
9	R/W	DIVN_OUTPUT_EN	DIVN output enable bit-field. When set, it enables the mapping of DIVN clock on dedicated GPIO (P0_15). The specific GPIO must be configured as GPIO output.	0x0
8	R/W	RC32M_OUTPUT_EN	RC32M output enable bit-field. When set, it enables the mapping of RC32M clock on dedicated GPIO (P0_13). The specific GPIO must be configured as GPIO output.	0x0
7	R/W	XTAL32M_OUTPUT_EN	XTAL32M output enable bit-field. When set, it enables the mapping of XTAL32M clock on dedicated GPIO (P0_12). The specific GPIO must be configured as GPIO output.	0x0
6	R/W	RCX_OUTPUT_EN	RCX output enable bit-field. When set, it enables the mapping of RCX clock on dedicated GPIO (P0_16). The specific GPIO must be configured as GPIO output.	0x0
5	R/W	RC32K_OUTPUT_EN	RC32K output enable bit-field. When set, it enables the mapping of RC32K clock on dedicated GPIO (P0_17). The specific GPIO must be configured as GPIO output.	0x0
4	R/W	XTAL32K_OUTPUT_EN	XTAL32K output enable bit-field. When set, it enables the mapping of XTAL32K clock on dedicated GPIO (P0_14). The specific GPIO must be configured as GPIO output.	0x0
3	R/W	FUNC_CLOCK_EN	If set, it enables the mapping of the selected clock signal, according to FUNC_CLOCK_SEL bit-field.	0x0
2:0	R/W	FUNC_CLOCK_SEL	Select which clock to map when PID = FUNC_CLOCK. 0x0: XTAL32K	0x0

Bit	Mode	Symbol	Description	Reset
			0x1: RC32K 0x2: RCX 0x3: XTAL32M 0x4: RC32M 0x5: DIVN 0x6: Reserved 0x7: Reserved	

Table 703: PAD_WEAK_CTRL_REG (0x50020B00)

Bit	Mode	Symbol	Description	Reset
12	R/W	P1_09_LOWDRV	0 = Normal operation 1 = Reduces the driving strength of P1_09 pad Note: This mode should be coupled with the selection of VDD1V8P supply rail for the specific pad (see also the description of P1_PADPWDR_CTRL_REG).	0x0
11	R/W	P1_06_LOWDRV	0 = Normal operation 1 = Reduces the driving strength of P1_06 pad Note: This mode should be coupled with the selection of VDD1V8P supply rail for the specific pad (see also the description of P1_PADPWDR_CTRL_REG).	0x0
10	R/W	P1_02_LOWDRV	0 = Normal operation 1 = Reduces the driving strength of P1_02 pad Note: This mode should be coupled with the selection of VDD1V8P supply rail for the specific pad (see also the description of P1_PADPWDR_CTRL_REG).	0x0
9	R/W	P1_01_LOWDRV	0 = Normal operation 1 = Reduces the driving strength of P1_01 pad Note: This mode should be coupled with the selection of VDD1V8P supply rail for the specific pad (see also the description of P1_PADPWDR_CTRL_REG).	0x0
8	R/W	P1_00_LOWDRV	0 = Normal operation 1 = Reduces the driving strength of P1_00 pad Note: This mode should be coupled with the selection of VDD1V8P supply rail for the specific pad (see also the description of P1_PADPWDR_CTRL_REG).	0x0
7	R/W	P0_27_LOWDRV	0 = Normal operation 1 = Reduces the driving strength of P0_27 pad Note: This mode should be coupled with the selection of VDD1V8P supply rail for the specific pad (see also the description of P0_PADPWDR_CTRL_REG).	0x0
6	R/W	P0_26_LOWDRV	0 = Normal operation 1 = Reduces the driving strength of P0_26 pad Note: This mode should be coupled with the selection of VDD1V8P supply rail for the specific pad (see also the description of P0_PADPWDR_CTRL_REG).	0x0
5	R/W	P0_25_LOWDRV	0 = Normal operation 1 = Reduces the driving strength of P0_25 pad	0x0

Bit	Mode	Symbol	Description	Reset
			Note: This mode should be coupled with the selection of VDD1V8P supply rail for the specific pad (see also the description of P0_PADPWDR_CTRL_REG).	
4	R/W	P0_18_LOWDRV	0 = Normal operation 1 = Reduces the driving strength of P0_18 pad Note: This mode should be coupled with the selection of VDD1V8P supply rail for the specific pad (see also the description of P0_PADPWDR_CTRL_REG).	0x0
3	R/W	P0_17_LOWDRV	0 = Normal operation 1 = Reduces the driving strength of P0_17 pad Note: This mode should be coupled with the selection of VDD1V8P supply rail for the specific pad (see also the description of P0_PADPWDR_CTRL_REG).	0x0
2	R/W	P0_16_LOWDRV	0 = Normal operation 1 = Reduces the driving strength of P0_16 pad Note: This mode should be coupled with the selection of VDD1V8P supply rail for the specific pad (see also the description of P0_PADPWDR_CTRL_REG).	0x0
1	R/W	P0_07_LOWDRV	0 = Normal operation 1 = Reduces the driving strength of P0_07 pad Note: This mode should be coupled with the selection of VDD1V8P supply rail for the specific pad (see also the description of P0_PADPWDR_CTRL_REG).	0x0
0	R/W	P0_06_LOWDRV	0 = Normal operation 1 = Reduces the driving strength of P0_06 pad Note: This mode should be coupled with the selection of VDD1V8P supply rail for the specific pad (see also the description of P0_PADPWDR_CTRL_REG).	0x0

42.23 General Purpose Registers

Table 704: Register map GPREG

Address	Register	Description
0x50040300	SET_FREEZE_REG	Controls freezing of various timers/counters (incl. DMA and USB).
0x50040304	RESET_FREEZE_REG	Controls unfreezing of various timers/counters (incl. DMA and USB).
0x50040308	DEBUG_REG	Various debug information register.
0x5004030C	GP_STATUS_REG	General purpose system status register.
0x50040310	GP_CONTROL_REG	General purpose system control register.
0x50040318	USBPAD_REG	USB pads control register

Table 705: [SET_FREEZE_REG](#) (0x50040300)

Bit	Mode	Symbol	Description	Reset
31:11	R	-	Reserved	0x0
10	R/W	FRZ_CMACE_WDOG	If '1', the CMACE SW Watchdog Timer is frozen, '0' is discarded.	0x0

Bit	Mode	Symbol	Description	Reset
9	R/W	FRZ_SWTIM4	If '1', the SW Timer4 is frozen, '0' is discarded.	0x0
8	R/W	FRZ_SWTIM3	If '1', the SW Timer3 is frozen, '0' is discarded.	0x0
7	R/W	FRZ_PWMLED	If '1', the PWM LED is frozen, '0' is discarded.	0x0
6	R/W	FRZ_SWTIM2	If '1', the SW Timer2 is frozen, '0' is discarded.	0x0
5	R/W	FRZ_DMA	If '1', the DMA is frozen, '0' is discarded.	0x0
4	R/W	FRZ_USB	If '1', the USB is frozen, '0' is discarded.	0x0
3	R/W	FRZ_SYS_WDOG	If '1', the SYS SW Watchdog Timer is frozen, '0' is discarded. WATCHDOG_CTRL_REG[NMI_RST] must be '0' to allow the freeze function.	0x0
2	R/W	FRZ_RESERVED		0x0
1	R/W	FRZ_SWTIM	If '1', the SW Timer is frozen, '0' is discarded.	0x0
0	R/W	FRZ_WKUPTIM	If '1', the Wake Up Timer is frozen, '0' is discarded.	0x0

Table 706: **RESET_FREEZE_REG (0x50040304)**

Bit	Mode	Symbol	Description	Reset
31:11	R	-	Reserved	0x0
10	R/W	FRZ_CMACE_WDOG	If '1', the CMACE SW Watchdog Timer continues, '0' is discarded.	0x0
9	R/W	FRZ_SWTIM4	If '1', the SW Timer4 continues, '0' is discarded.	0x0
8	R/W	FRZ_SWTIM3	If '1', the SW Timer3 continues, '0' is discarded.	0x0
7	R/W	FRZ_PWMLED	If '1', the PWM LED continues, '0' is discarded.	0x0
6	R/W	FRZ_SWTIM2	If '1', the SW Timer2 continues, '0' is discarded.	0x0
5	R/W	FRZ_DMA	If '1', the DMA continues, '0' is discarded.	0x0
4	R/W	FRZ_USB	If '1', the USB continues, '0' is discarded.	0x0
3	R/W	FRZ_SYS_WDOG	If '1', the SYS SW Watchdog Timer continues, '0' is discarded.	0x0
2	R/W	FRZ_RESERVED		0x0
1	R/W	FRZ_SWTIM	If '1', the SW Timer continues, '0' is discarded.	0x0
0	R/W	FRZ_WKUPTIM	If '1', the Wake Up Timer continues, '0' is discarded.	0x0

Table 707: **DEBUG_REG (0x50040308)**

Bit	Mode	Symbol	Description	Reset
31:16	R	-	Reserved	0x0
15:10	R	-	Reserved	0x0
9	R/W	-	Reserved	0x0
8	R/W	CROSS_CPU_HALT_SENSITIVITY	Select the cross CPU halt sensitivity. 0: Level triggered, 1: Pulse triggered. Note: This bit is retained.	0x1
7	R/W	SYS_CPUWAIT_ON_JTAG	1: Stall the processor core out of reset (only after a wake-up from JTAG). Debugger access continue when	0x0

Bit	Mode	Symbol	Description	Reset
			the core is stalled. When set to '0' again the core resumes instruction execution. This feature is independent of the PDC (Power Domain Controller) settings. If this bit is set and there is SW/JTAG activity during deep sleep, the SYS CPU is stalled after the wake-up. Note: This bit is retained.	
6	R/W	SYS_CPUWAIT	1: Stall the processor core out of reset (always after a wake-up). Debugger access continue when the core is stalled. When set to '0' again the core resumes instruction execution. Note: This bit is retained.	0x0
5	R	CMAC_CPU_IS_HALTED	1: CMAC CPU is halted.	0x0
4	R	SYS_CPU_IS_HALTED	1: SYS CPU (ARM CM33) is halted.	0x0
3	R/W	HALT_CMAC_SYS_CPU_EN	1: Enable CMAC CPU halting to the SYS CPU (ARM CM33). Note 1: This bit is retained. Note 2: Set this bit to '0' before going into deep sleep to prevent unpredictable halting behavior after waking up.	0x0
2	R/W	HALT_SYS_CMAC_CPU_EN	1: Enable SYS CPU (ARM CM33) halting to the CMAC CPU. Note 1: This bit is retained. Note 2: Set this bit to '0' before going into deep sleep to prevent unpredictable halting behavior after waking up.	0x0
1	R/W	CMAC_CPU_FREEZE_EN	1: Enable Freezing <u>on-chip peripherals</u> (see Note 2) by the CMAC CPU. Note 1: This bit is retained. Note 2: See [RE]SET_FREEZE_REG for the specific <u>on-chip peripherals</u> .	0x0
0	R/W	SYS_CPU_FREEZE_EN	1: Enable Freezing <u>on-chip peripherals</u> (see Note 2) by the SYS CPU (ARM CM33). Default '1', freezing of the on-chip peripherals is enabled when the Cortex-M33 is halted in DEBUG State. If '0', freezing of the on-chip peripherals is <u>only</u> depending on [RE]SET_FREEZE_REG <u>except</u> the system watchdog timer. The system watchdog timer is always frozen when the Cortex-M33 is halted in DEBUG State. Note 1: This bit is retained. Note 2: See [RE]SET_FREEZE_REG for the specific <u>on-chip peripherals</u> .	0x1

Table 708: GP_STATUS_REG (0x5004030C)

Bit	Mode	Symbol	Description	Reset
31:2	R	-	Reserved	0x0
1	R/W	-	Reserved	0x0

Bit	Mode	Symbol	Description	Reset
0	R/W	CAL_PHASE	If '1', it designates that the chip is in Calibration Phase i.e. the OTP has been initially programmed but no Calibration has occurred.	0x0

Table 709: GP_CONTROL_REG (0x50040310)

Bit	Mode	Symbol	Description	Reset
31:2	R	-	Reserved	0x0
1	R/W	CMAC_H2H_BRIDGE_BYPASS	If '1', the AHB-to-AHB bridge is bypassed, reducing the wait cycles needed to access the CMAC Register File, only when the system clock source is the XTAL and both hclk and cmac_hclk are running at 32 MHz, i.e. at the XTAL clock rate.	0x0
0	R/W	-	Reserved	0x0

Table 710: USBPAD_REG (0x50040318)

Bit	Mode	Symbol	Description	Reset
2	R/W	USBPHY_FORCE_SW2_ON	0: Pull up resistor SW2 is controlled by the USB controller. It is off when the USB is not enabled. 1: Force the pull up resistor on USBP to be 2.3Kohm	0x0
1	R/W	USBPHY_FORCE_SW1_OFF	0: Pull up resistor SW1 is controlled by the USB controller. It is off when the USB is not enabled. 1: Force the pull up resistor on USBP to be switched off.	0x0
0	R/W	USBPAD_EN	0: The power for the USB PHY and USB pads is switched on when the USB is enabled. 1: The power for the USB PHY and USB pads is forced on.	0x0

42.24 I2C Controller Registers

Table 711: Register map I2C

Address	Register	Description
0x50020600	I2C_CON_REG	I2C Control Register
0x50020604	I2C_TAR_REG	I2C Target Address Register
0x50020608	I2C_SAR_REG	I2C Slave Address Register
0x5002060c	I2C_HS_MADDR_REG	I2C High Speed Master Mode Code Address Register
0x50020610	I2C_DATA_CMD_REG	I2C Rx/Tx Data Buffer and Command Register
0x50020614	I2C_SS_SCL_HCNT_REG	Standard Speed I2C Clock SCL High Count Register
0x50020618	I2C_SS_SCL_LCNT_REG	Standard Speed I2C Clock SCL Low Count Register
0x5002061c	I2C_FS_SCL_HCNT_REG	Fast Speed I2C Clock SCL High Count Register
0x50020620	I2C_FS_SCL_LCNT_REG	Fast Speed I2C Clock SCL Low Count Register

Multi-Core Bluetooth 5.2 SoC Family with System PMU

Address	Register	Description
0x50020624	I2C_HS_SCL_HCNT_REG	High Speed I2C Clock SCL High Count Register
0x50020628	I2C_HS_SCL_LCNT_REG	High Speed I2C Clock SCL Low Count Register
0x5002062c	I2C_INTR_STAT_REG	I2C Interrupt Status Register
0x50020630	I2C_INTR_MASK_REG	I2C Interrupt Mask Register
0x50020634	I2C_RAW_INTR_STAT_REG	I2C Raw Interrupt Status Register
0x50020638	I2C_RX_TL_REG	I2C Receive FIFO Threshold Register
0x5002063c	I2C_TX_TL_REG	I2C Transmit FIFO Threshold Register
0x50020640	I2C_CLR_INTR_REG	Clear Combined and Individual Interrupt Register
0x50020644	I2C_CLR_RX_UNDER_REG	Clear RX_UNDER Interrupt Register
0x50020648	I2C_CLR_RX_OVER_REG	Clear RX_OVER Interrupt Register
0x5002064c	I2C_CLR_TX_OVER_REG	Clear TX_OVER Interrupt Register
0x50020650	I2C_CLR_RD_REQ_REG	Clear RD_REQ Interrupt Register
0x50020654	I2C_CLR_TX_ABRT_REG	Clear TX_ABRT Interrupt Register
0x50020658	I2C_CLR_RX_DONE_REG	Clear RX_DONE Interrupt Register
0x5002065c	I2C_CLR_ACTIVITY_REG	Clear ACTIVITY Interrupt Register
0x50020660	I2C_CLR_STOP_DET_REG	Clear STOP_DET Interrupt Register
0x50020664	I2C_CLR_START_DET_REG	Clear START_DET Interrupt Register
0x50020668	I2C_CLR_GEN_CALL_REG	Clear GEN_CALL Interrupt Register
0x5002066c	I2C_ENABLE_REG	I2C Enable Register
0x50020670	I2C_STATUS_REG	I2C Status Register
0x50020674	I2C_TXFLR_REG	I2C Transmit FIFO Level Register
0x50020678	I2C_RXFLR_REG	I2C Receive FIFO Level Register
0x5002067c	I2C_SDA_HOLD_REG	I2C SDA Hold Time Length Register
0x50020680	I2C_TX_ABRT_SOURCE_REG	I2C Transmit Abort Source Register
0x50020688	I2C_DMA_CR_REG	DMA Control Register
0x5002068c	I2C_DMA_TDLR_REG	DMA Transmit Data Level Register
0x50020690	I2C_DMA_RDLR_REG	I2C Receive Data Level Register
0x50020694	I2C_SDA_SETUP_REG	I2C SDA Setup Register
0x50020698	I2C_ACK_GENERAL_CALL_REG	I2C ACK General Call Register
0x5002069c	I2C_ENABLE_STATUS_REG	I2C Enable Status Register

Multi-Core Bluetooth 5.2 SoC Family with System PMU

Address	Register	Description
0x500206a0	I2C_IC_FS_SPKLEN_REG	I2C SS and FS spike suppression limit Size
0x500206a4	I2C_IC_HS_SPKLEN_REG	I2C HS spike suppression limit Size
0x50020700	I2C2_CON_REG	I2C Control Register
0x50020704	I2C2_TAR_REG	I2C Target Address Register
0x50020708	I2C2_SAR_REG	I2C Slave Address Register
0x5002070c	I2C2_HS_MADDR_REG	I2C High Speed Master Mode Code Address Register
0x50020710	I2C2_DATA_CMD_REG	I2C Rx/Tx Data Buffer and Command Register
0x50020714	I2C2_SS_SCL_HCNT_REG	Standard Speed I2C Clock SCL High Count Register
0x50020718	I2C2_SS_SCL_LCNT_REG	Standard Speed I2C Clock SCL Low Count Register
0x5002071c	I2C2_FS_SCL_HCNT_REG	Fast Speed I2C Clock SCL High Count Register
0x50020720	I2C2_FS_SCL_LCNT_REG	Fast Speed I2C Clock SCL Low Count Register
0x50020724	I2C2_HS_SCL_HCNT_REG	High Speed I2C Clock SCL High Count Register
0x50020728	I2C2_HS_SCL_LCNT_REG	High Speed I2C Clock SCL Low Count Register
0x5002072c	I2C2_INTR_STAT_REG	I2C Interrupt Status Register
0x50020730	I2C2_INTR_MASK_REG	I2C Interrupt Mask Register
0x50020734	I2C2_RAW_INTR_STAT_REG	I2C Raw Interrupt Status Register
0x50020738	I2C2_RX_TL_REG	I2C Receive FIFO Threshold Register
0x5002073c	I2C2_TX_TL_REG	I2C Transmit FIFO Threshold Register
0x50020740	I2C2_CLR_INTR_REG	Clear Combined and Individual Interrupt Register
0x50020744	I2C2_CLR_RX_UNDER_REG	Clear RX_UNDER Interrupt Register
0x50020748	I2C2_CLR_RX_OVER_REG	Clear RX_OVER Interrupt Register
0x5002074c	I2C2_CLR_TX_OVER_REG	Clear TX_OVER Interrupt Register
0x50020750	I2C2_CLR_RD_REQ_REG	Clear RD_REQ Interrupt Register
0x50020754	I2C2_CLR_TX_ABRT_REG	Clear TX_ABRT Interrupt Register
0x50020758	I2C2_CLR_RX_DONE_REG	Clear RX_DONE Interrupt Register
0x5002075c	I2C2_CLR_ACTIVITY_REG	Clear ACTIVITY Interrupt Register
0x50020760	I2C2_CLR_STOP_DET_REG	Clear STOP_DET Interrupt Register
0x50020764	I2C2_CLR_START_DET_REG	Clear START_DET Interrupt Register

Address	Register	Description
0x50020768	I2C2_CLR_GEN_CALL_REG	Clear GEN_CALL Interrupt Register
0x5002076c	I2C2_ENABLE_REG	I2C Enable Register
0x50020770	I2C2_STATUS_REG	I2C Status Register
0x50020774	I2C2_TXFLR_REG	I2C Transmit FIFO Level Register
0x50020778	I2C2_RXFLR_REG	I2C Receive FIFO Level Register
0x5002077c	I2C2_SDA_HOLD_REG	I2C SDA Hold Time Length Register
0x50020780	I2C2_TX_ABRT_SOURCE_REG	I2C Transmit Abort Source Register
0x50020788	I2C2_DMA_CR_REG	DMA Control Register
0x5002078c	I2C2_DMA_TDLR_REG	DMA Transmit Data Level Register
0x50020790	I2C2_DMA_RDLR_REG	I2C Receive Data Level Register
0x50020794	I2C2_SDA_SETUP_REG	I2C SDA Setup Register
0x50020798	I2C2_ACK_GENERAL_CALL_REG	I2C ACK General Call Register
0x5002079c	I2C2_ENABLE_STATUS_REG	I2C Enable Status Register
0x500207a0	I2C2_IC_FS_SPKLEN_REG	I2C SS and FS spike suppression limit Size
0x500207a4	I2C2_IC_HS_SPKLEN_REG	I2C HS spike suppression limit Size

Table 712: I2C_CON_REG (0x50020600)

Bit	Mode	Symbol/Description	Reset
31:11	-	- Reserved	0x0
10	R	I2C_STOP_DET_IF_MASTER_ACTIVE In Master mode: 1 = Issue the STOP_DET interrupt only when master is active. 0 = Issue the STOP_DET irrespective of whether master is active or not.	0x0
9	R/W	I2C_RX_FIFO_FULL_HLD_CTRL This bit controls whether DW_apb_i2c should hold the bus when the RX FIFO is physically full to its RX_BUFFER_DEPTH. 1 = Hold bus when RX_FIFO is full. 0 = Overflow when RX_FIFO is full.	0x0
8	R/W	I2C_TX_EMPTY_CTRL This bit controls the generation of the TX_EMPTY interrupt as described in the IC_RAW_INTR_STAT register. 1 = Controlled generation of TX_EMPTY interrupt. 0 = Default behaviour of TX_EMPTY interrupt.	0x0
7	R/W	I2C_STOP_DET_IFADDRESSED 1 = Slave issues STOP_DET intr only if addressed. 0 = Slave issues STOP_DET intr always. During a general call address, this slave does not issue the STOP_DET interrupt if STOP_DET_IF_ADDRESSED = 1'b1, even if the slave responds to the general	0x0

Bit	Mode	Symbol/Description	Reset
		call address by generating ACK. The STOP_DET interrupt is generated only when the transmitted address matches the slave address (SAR).	
6	R/W	I2C_SLAVE_DISABLE Slave enabled or disabled after reset is applied, which means software does not have to configure the slave. 0 = Slave is enabled. 1 = Slave is disabled. Software should ensure that if this bit is written with '0', then bit 0 should also be written with a '0'.	0x1
5	R/W	I2C_RESTART_EN Determine whether RESTART conditions may be sent when acting as a master. 0 = Disable 1 = Enable	0x1
4	R/W	I2C_10BITADDR_MASTER Control whether the controller starts its transfers in 7- or 10-bit addressing mode when acting as a master. 0 = 7-bit addressing 1 = 10-bit addressing	0x1
3	R/W	I2C_10BITADDR_SLAVE When acting as a slave, this bit controls whether the controller responds to 7- or 10-bit addresses. 0 = 7-bit addressing 1 = 10-bit addressing	0x1
2:1	R/W	I2C_SPEED These bits control at which speed the controller operates. 1 = Standard mode (100 kbit/s) 2 = Fast mode (400 kbit/s) 3 = High speed mode	0x3
0	R/W	I2C_MASTER_MODE This bit controls whether the controller master is enabled. 0 = Master disabled 1 = Master enabled Software should ensure that if this bit is written with '1' then bit 6 should also be written with a '1'.	0x1

Table 713: I2C_TAR_REG (0x50020604)

Bit	Mode	Symbol/Description	Reset
31:12	-	- Reserved	0x0
11	R/W	SPECIAL On read This bit indicates whether software performs a General Call or START BYTE command. 0 = Ignore bit 10 GC_OR_START and use IC_TAR normally. 1 = Perform special I2C command as specified in GC_OR_START bit.	0x0

Bit	Mode	Symbol/Description	Reset
		On write 1 = Enables programming of GENERAL_CALL or START_BYTE transmission. 0 = Disables programming of GENERAL_CALL or START_BYTE transmission. Write to this register succeed only when IC_ENABLE[0] is set to 0.	
10	R/W	GC_OR_START On read If bit 11 (SPECIAL) is set to 1, then this bit indicates whether a General Call or START byte command is to be performed by the controller. 0 = General Call Address - after issuing a General Call, only writes may be performed. Attempting to issue a read command results in setting bit 6 (TX_ABRT) of the IC_RAW_INTR_STAT register. The controller remains in General Call mode until the SPECIAL bit value (bit 11) is cleared. 1 = START BYTE On write 1 = START byte transmission 0 = GENERAL_CALL byte transmission Write to this register succeed only when IC_ENABLE[0] is set to 0.	0x0
9:0	R/W	IC_TAR This is the target address for any master transaction. When transmitting a General Call, these bits are ignored. To generate a START BYTE, the CPU needs to write only once into these bits. Note: If the IC_TAR and IC_SAR are the same, loopback exists but the FIFOs are shared between master and slave, so full loopback is not feasible. Only one direction loopback mode is supported (simplex), not duplex. A master cannot transmit to itself; it can transmit to only a slave. Write to this register succeed only when IC_ENABLE[0] is set to 0.	0x55

Table 714: I2C_SAR_REG (0x50020608)

Bit	Mode	Symbol/Description	Reset
31:10	-	- Reserved	0x0
9:0	R/W	IC_SAR The IC_SAR holds the slave address when the I2C is operating as a slave. For 7-bit addressing, only IC_SAR[6:0] is used. This register can be written only when the I2C interface is disabled, which corresponds to the IC_ENABLE register being set to 0. Write at other times have no effect. Write to this register succeed only when IC_ENABLE[0] is set to 0.	0x55

Table 715: I2C_HS_MADDR_REG (0x5002060C)

Bit	Mode	Symbol/Description	Reset
2:0	R/W	I2C_IC_HS_MAR This bit field holds the value of the I2C HS mode master code. HS-mode master codes are reserved 8-bit codes (00001xxx) that are not used for slave addressing or other purposes. Each master has its unique master code; up to eight high-speed mode masters can be present on the same I2C bus system. Valid values are from 0 to 7. This register can be written only when the I2C interface is disabled, which corresponds to the IC_ENABLE[0] register being set to 0. Write at other times have no effect.	0x1

Table 716: I2C_DATA_CMD_REG (0x50020610)

Bit	Mode	Symbol/Description	Reset
30:11	-	- Reserved	0x0
10	W	I2C_RESTART This bit controls whether a RESTART is issued before the byte is sent or received. 1 = If IC_RESTART_EN is 1, a RESTART is issued before the data is sent/received (according to the value of CMD), regardless of whether or not the transfer direction is changing from the previous command; if IC_RESTART_EN is 0, a STOP followed by a START is issued instead. 0 = If IC_RESTART_EN is 1, a RESTART is issued only if the transfer direction is changing from the previous command; if IC_RESTART_EN is 0, a STOP followed by a START is issued instead.	0x0
9	W	I2C_STOP This bit controls whether a STOP is issued after the byte is sent or received. 1 = STOP is issued after this byte, regardless of whether or not the TX FIFO is empty. If the TX FIFO is not empty, the master immediately tries to start a new transfer by issuing a START and arbitrating for the bus. 0 = STOP is not issued after this byte, regardless of whether or not the TX FIFO is empty. If the TX FIFO is not empty, the master continues the current transfer by sending/receiving data bytes according to the value of the CMD bit. If the TX FIFO is empty, the master holds the SCL line low and stalls the bus until a new command is available in the TX FIFO.	0x0
8	W	I2C_CMD This bit controls whether a read or a write is performed. This bit does not control the direction when the I2C Ctrl acts as a slave. It controls only the direction when it acts as a master. 1 = Read 0 = Write When a command is entered in the TX FIFO, this bit distinguishes the write and read commands. In slave-receiver mode, this bit is a "don't care" because writes to this register are not required. In slave-transmitter mode, a "0" indicates that CPU data is to be transmitted and as DAT or IC_DATA_CMD[7:0]. When programming this bit, you should remember the following: attempting to perform a read operation after a General Call command has been sent results in a TX_ABRT interrupt (bit 6 of the I2C_RAW_INTR_STAT_REG), unless bit 11 (SPECIAL) in the I2C_TAR register has been cleared. If a "1" is written to this bit after receiving a RD_REQ interrupt, then a TX_ABRT interrupt occurs. NOTE: It is possible that while attempting a master I2C read transfer on the controller, a RD_REQ interrupt may have occurred simultaneously due to a remote I2C master addressing the controller. In this type of scenario, it ignores the I2C_DATA_CMD write, generates a TX_ABRT interrupt, and waits to service the RD_REQ interrupt.	0x0
7:0	R/W	I2C_DAT This register contains the data to be transmitted or received on the I2C bus. If you are writing to this register and want to perform a read, bits 7:0 (DAT) are ignored by the controller. However, when you read this register, these bits return the value of data received on the controller's interface.	0x0

Table 717: **I2C_SS_SCL_HCNT_REG (0x50020614)**

Bit	Mode	Symbol/Description	Reset
15:0	R/W	<p>IC_SS_SCL_HCNT</p> <p>This register must be set before any I2C bus transaction can take place to ensure proper I/O timing. This register sets the SCL clock high-period count for standard speed. This register can be written only when the I2C interface is disabled which corresponds to the IC_ENABLE register being set to 0. Write at other times have no effect.</p> <p>The minimum valid value is 6; hardware prevents values less than this being written, and if attempted results in 6 being set.</p> <p>NOTE: This register must not be programmed to a value higher than 65525, because the controller uses a 16-bit counter to flag an I2C bus idle condition when this counter reaches a value of IC_SS_SCL_HCNT + 10.</p>	0x91

Table 718: **I2C_SS_SCL_LCNT_REG (0x50020618)**

Bit	Mode	Symbol/Description	Reset
15:0	R/W	<p>IC_SS_SCL_LCNT</p> <p>This register must be set before any I2C bus transaction can take place to ensure proper I/O timing. This register sets the SCL clock low period count for standard speed.</p> <p>This register can be written only when the I2C interface is disabled which corresponds to the I2C_ENABLE register being set to 0. Write at other times have no effect.</p> <p>The minimum valid value is 8; hardware prevents values less than this being written, and if attempted, results in 8 being set.</p>	0xAB

Table 719: **I2C_FS_SCL_HCNT_REG (0x5002061C)**

Bit	Mode	Symbol/Description	Reset
15:0	R/W	<p>IC_FS_SCL_HCNT</p> <p>This register must be set before any I2C bus transaction can take place to ensure proper I/O timing. This register sets the SCL clock high-period count for fast speed. It is used in high-speed mode to send the Master Code and START BYTE or General CALL. This register can be written only when the I2C interface is disabled, which corresponds to the I2C_ENABLE register being set to 0. Writes at other times have no effect.</p> <p>The minimum valid value is 6; hardware prevents values less than this being written, and if attempted results in 6 being set.</p>	0x1A

Table 720: **I2C_FS_SCL_LCNT_REG (0x50020620)**

Bit	Mode	Symbol/Description	Reset
15:0	R/W	<p>IC_FS_SCL_LCNT</p> <p>This register must be set before any I2C bus transaction can take place to ensure proper I/O timing. This register sets the SCL clock low-period count for fast speed. It is used in high-speed mode to send the Master Code and START BYTE or General CALL. This register can be written only when the I2C interface is disabled, which corresponds to the I2C_ENABLE register being set to 0. Write at other times have no effect.</p> <p>The minimum valid value is 8; hardware prevents values less than this being written, and if attempted results in 8 being set. For designs with APB_DATA_WIDTH = 8, the order of programming is important to ensure the</p>	0x32

Bit	Mode	Symbol/Description	Reset
		correct operation of the controller. The lower byte must be programmed first. Then the upper byte is programmed.	

Table 721: **I2C_HS_SCL_HCNT_REG (0x50020624)**

Bit	Mode	Symbol/Description	Reset
15:0	R/W	<p>IC_HS_SCL_HCNT</p> <p>This register must be set before any I2C bus transaction can take place to ensure proper I/O timing. This register sets the SCL clock high period count for high speed. See "IC_CLK Frequency Configuration".</p> <p>The SCL High time depends on the loading of the bus. For 100 pF loading, the SCL High time is 60 ns; for 400 pF loading, the SCL High time is 120 ns. This register goes away and becomes read-only returning 0s if IC_MAX_SPEED_MODE != high.</p> <p>This register can be written only when the I2C interface is disabled, which corresponds to the IC_ENABLE[0] register being set to 0. Write at other times have no effect.</p> <p>The minimum valid value is 6; hardware prevents values less than this being written, and if attempted results in 6 being set. For designs with APB_DATA_WIDTH = 8, the order of programming is important to ensure the correct operation of the DW_apb_i2c. The lower byte must be programmed first. Then the upper byte is programmed.</p>	0x6

Table 722: **I2C_HS_SCL_LCNT_REG (0x50020628)**

Bit	Mode	Symbol/Description	Reset
15:0	R/W	<p>IC_HS_SCL_LCNT</p> <p>This register must be set before any I2C bus transaction can take place to ensure proper I/O timing. This register sets the SCL clock low period count for high speed. For more information, see "IC_CLK Frequency Configuration".</p> <p>The SCL low time depends on the loading of the bus. For 100 pF loading, the SCL low time is 160 ns; for 400 pF loading, the SCL low time is 320 ns. This register goes away and becomes read-only returning 0s if IC_MAX_SPEED_MODE != high.</p> <p>This register can be written only when the I2C interface is disabled, which corresponds to the IC_ENABLE[0] register being set to 0. Write at other times have no effect.</p> <p>The minimum valid value is 8; hardware prevents values less than this being written, and if attempted results in 8 being set. For designs with APB_DATA_WIDTH == 8, the order of programming is important to ensure the correct operation of the DW_apb_i2c. The lower byte must be programmed first. Then the upper byte is programmed. If the value is less than 8 then the count value gets changed to 8.</p>	0x10

Table 723: **I2C_INTR_STAT_REG (0x5002062C)**

Bit	Mode	Symbol/Description	Reset
31:15	-	- Reserved	0x0
14	R	<p>R_SCL_STUCK_AT_LOW</p> <p>1 = R_SCL_STUCK_AT_LOW interrupt is active. 0 = R_SCL_STUCK_AT_LOW interrupt is inactive.</p>	0x0

Bit	Mode	Symbol/Description	Reset
13	R	<p>R_MASTER_ON_HOLD</p> <p>Indicate whether master is holding the bus and TX FIFO is empty. Enabled only when I2C_DYNAMIC_TAR_UPDATE=1 and IC_EMPTYFIFO_HOLD_MASTER_EN=1.</p>	0x0
12	R	<p>R_RESTART_DET</p> <p>Indicate whether a RESTART condition has occurred on the I2C interface when DW_apb_i2c is operating in Slave mode and the slave is being addressed. Enabled only when IC_SLV_RESTART_DET_EN=1.</p> <p>Note: However, in high-speed mode or during a START BYTE transfer, the RESTART comes before the address field as per the I2C protocol. In this case, the slave is not the addressed slave when the RESTART is issued, therefore DW_apb_i2c does not generate the RESTART_DET interrupt.</p>	0x0
11	R	<p>R_GEN_CALL</p> <p>Set only when a General Call address is received and it is acknowledged. It stays set until it is cleared either by disabling controller or when the CPU reads bit 0 of the I2C_CLR_GEN_CALL register. The controller stores the received data in the RX buffer.</p>	0x0
10	R	<p>R_START_DET</p> <p>Indicate whether a START or RESTART condition has occurred on the I2C interface regardless of whether controller is operating in slave or master mode.</p>	0x0
9	R	<p>R_STOP_DET</p> <p>Indicate whether a STOP condition has occurred on the I2C interface regardless of whether controller is operating in slave or master mode.</p>	0x0
8	R	<p>R_ACTIVITY</p> <p>This bit captures I2C Ctrl activity and stays set until it is cleared. There are four ways to clear it:</p> <ul style="list-style-type: none"> => Disabling the I2C Ctrl => Reading the IC_CLR_ACTIVITY register => Reading the IC_CLR_INTR register => System reset <p>Once this bit is set, it stays set unless one of the four methods is used to clear it. Even if the controller module is idle, this bit remains set until cleared, indicating that there was activity on the bus.</p>	0x0
7	R	<p>R_RX_DONE</p> <p>When the controller is acting as a slave-transmitter, this bit is set to 1 if the master does not acknowledge a transmitted byte. This occurs on the last byte of the transmission, indicating that the transmission is done.</p>	0x0
6	R	<p>R_TX_ABORT</p> <p>This bit indicates if the controller, as an I2C transmitter, is unable to complete the intended actions on the contents of the transmit FIFO. This situation can occur both as an I2C master or an I2C slave, and is referred to as a "transmit abort".</p> <p>When this bit is set to 1, the I2C_TX_ABORT_SOURCE register indicates the reason why the transmit abort takes places.</p> <p>NOTE: The controller flushes/resets/empties the TX FIFO whenever this bit is set. The TX FIFO remains in this flushed state until the register I2C_CLR_TX_ABORT is read. Once this read is performed, the TX FIFO is then ready to accept more data bytes from the APB interface.</p>	0x0
5	R	<p>R_RD_REQ</p> <p>This bit is set to 1 when the controller is acting as a slave and another I2C master is attempting to read data from the controller. The controller holds the I2C bus in a</p>	0x0

Bit	Mode	Symbol/Description	Reset
		wait state (SCL=0) until this interrupt is serviced, which means that the slave has been addressed by a remote master that is asking for data to be transferred. The processor must respond to this interrupt and then write the requested data to the I2C_DATA_CMD register. This bit is set to 0 just after the processor reads the I2C_CLR_RD_REQ register.	
4	R	R_TX_EMPTY This bit is set to 1 when the transmit buffer is at or below the threshold value set in the I2C_TX_TL register. It is automatically cleared by hardware when the buffer level goes above the threshold. When the IC_ENABLE bit 0 is 0, the TX FIFO is flushed and held in reset. There the TX FIFO looks like it has no data within it, so this bit is set to 1, provided there is activity in the master or slave state machines. When there is no longer activity, then with ic_en=0, this bit is set to 0.	0x0
3	R	R_TX_OVER Set during transmit if the transmit buffer is filled to 32 and the processor attempts to issue another I2C command by writing to the IC_DATA_CMD register. When the module is disabled, this bit keeps its level until the master or slave state machines go into idle, and when ic_en goes to 0, this interrupt is cleared	0x0
2	R	R_RX_FULL Set when the receive buffer reaches or goes above the RX_TL threshold in the I2C_RX_TL register. It is automatically cleared by hardware when buffer level goes below the threshold. If the module is disabled (I2C_ENABLE[0]=0), the RX FIFO is flushed and held in reset; therefore the RX FIFO is not full. So this bit is cleared once, the I2C_ENABLE bit 0 is programmed with a 0 regardless of the activity that continues.	0x0
1	R	R_RX_OVER Set if the receive buffer is completely filled to 32 and an additional byte is received from an external I2C device. The controller acknowledges this, but any data bytes received after the FIFO is full are lost. If the module is disabled (I2C_ENABLE[0]=0), this bit keeps its level until the master or slave state machines go into idle, and when ic_en goes to 0, this interrupt is cleared.	0x0
0	R	R_RX_UNDER Set if the processor attempts to read the receive buffer when it is empty by reading from the IC_DATA_CMD register. If the module is disabled (I2C_ENABLE[0]=0), this bit keeps its level until the master or slave state machines go into idle, and when ic_en goes to 0, this interrupt is cleared.	0x0

Table 724: I2C_INTR_MASK_REG (0x50020630)

Bit	Mode	Symbol/Description	Reset
31:15	-	- Reserved	0x0
14	R	M_SCL_STUCK_AT_LOW M_SCL_STUCK_AT_LOW Register field Reserved bits.	0x0
13	R/W	M_MASTER_ON_HOLD These bits mask their corresponding interrupt status bits in the I2C_INTR_STAT register.	0x0
12	R/W	M_RESTART_DET These bits mask their corresponding interrupt status bits in the I2C_INTR_STAT register.	0x0
11	R/W	M_GEN_CALL	0x1

Bit	Mode	Symbol/Description	Reset
		These bits mask their corresponding interrupt status bits in the I2C_INTR_STAT register.	
10	R/W	M_START_DET These bits mask their corresponding interrupt status bits in the I2C_INTR_STAT register.	0x0
9	R/W	M_STOP_DET These bits mask their corresponding interrupt status bits in the I2C_INTR_STAT register.	0x0
8	R/W	M_ACTIVITY These bits mask their corresponding interrupt status bits in the I2C_INTR_STAT register.	0x0
7	R/W	M_RX_DONE These bits mask their corresponding interrupt status bits in the I2C_INTR_STAT register.	0x1
6	R/W	M_TX_ABRT These bits mask their corresponding interrupt status bits in the I2C_INTR_STAT register.	0x1
5	R/W	M_RD_REQ These bits mask their corresponding interrupt status bits in the I2C_INTR_STAT register.	0x1
4	R/W	M_TX_EMPTY These bits mask their corresponding interrupt status bits in the I2C_INTR_STAT register.	0x1
3	R/W	M_TX_OVER These bits mask their corresponding interrupt status bits in the I2C_INTR_STAT register.	0x1
2	R/W	M_RX_FULL These bits mask their corresponding interrupt status bits in the I2C_INTR_STAT register.	0x1
1	R/W	M_RX_OVER These bits mask their corresponding interrupt status bits in the I2C_INTR_STAT register.	0x1
0	R/W	M_RX_UNDER These bits mask their corresponding interrupt status bits in the I2C_INTR_STAT register.	0x1

Table 725: I2C_RAW_INTR_STAT_REG (0x50020634)

Bit	Mode	Symbol/Description	Reset
31:15	-	- Reserved	0x0
14	R	SCL_STUCK_AT_LOW CL_STUCK_AT_LOW Register field Reserved bits.	0x0
13	R	MASTER_ON_HOLD	0x0

Bit	Mode	Symbol/Description	Reset
		ndicate whether master is holding the bus and TX FIFO is empty. Enabled only when I2C_DYNAMIC_TAR_UPDATE=1 and IC_EMPTYFIFO_HOLD_MASTER_EN=1.	
12	R	RESTART_DET Indicate whether a RESTART condition has occurred on the I2C interface when DW_apb_i2c is operating in Slave mode and the slave is being addressed. Enabled only when IC_SLV_RESTART_DET_EN=1. Note: However, in high-speed mode or during a START BYTE transfer, the RESTART comes before the address field as per the I2C protocol. In this case, the slave is not the addressed slave when the RESTART is issued, therefore DW_apb_i2c does not generate the RESTART_DET interrupt.	0x0
11	R	GEN_CALL Set only when a General Call address is received and it is acknowledged. It stays set until it is cleared either by disabling controller or when the CPU reads bit 0 of the I2C_CLR_GEN_CALL register. I2C Ctrl stores the received data in the Rx buffer.	0x0
10	R	START_DET Indicate whether a START or RESTART condition has occurred on the I2C interface regardless of whether controller is operating in slave or master mode.	0x0
9	R	STOP_DET Indicate whether a STOP condition has occurred on the I2C interface regardless of whether controller is operating in slave or master mode.	0x0
8	R	ACTIVITY This bit captures I2C Ctrl activity and stays set until it is cleared. There are four ways to clear it: => Disabling the I2C Ctrl => Reading the IC_CLR_ACTIVITY register => Reading the IC_CLR_INTR register => System reset Once this bit is set, it stays set unless one of the four methods is used to clear it. Even if the controller module is idle, this bit remains set until cleared, indicating that there was activity on the bus.	0x0
7	R	RX_DONE When the controller is acting as a slave-transmitter, this bit is set to 1 if the master does not acknowledge a transmitted byte. This occurs on the last byte of the transmission, indicating that the transmission is done.	0x0
6	R	TX_ABRT This bit indicates if the controller, as an I2C transmitter, is unable to complete the intended actions on the contents of the transmit FIFO. This situation can occur both as an I2C master or an I2C slave and is referred to as a "transmit abort". When this bit is set to 1, the I2C_TX_ABRT_SOURCE register indicates the reason why the transmit abort takes place. NOTE: The controller flushes/resets/empties the TX FIFO whenever this bit is set. The TX FIFO remains in this flushed state until the register I2C_CLR_TX_ABRT is read. When this read is performed, the TX FIFO is then ready to accept more data bytes from the APB interface.	0x0
5	R	RD_REQ This bit is set to 1 when I2C Ctrl is acting as a slave and another I2C master is attempting to read data from the controller. The controller holds the I2C bus in a wait state (SCL=0) until this interrupt is serviced, which means that the slave has been addressed by a remote master that is asking for data to be transferred. The	0x0

Bit	Mode	Symbol/Description	Reset
		processor must respond to this interrupt and then write the requested data to the I2C_DATA_CMD register. This bit is set to 0 just after the processor reads the I2C_CLR_RD_REQ register.	
4	R	<p>TX_EMPTY</p> <p>This bit is set to 1 when the transmit buffer is at or below the threshold value set in the I2C_TX_TL register. It is automatically cleared by hardware when the buffer level goes above the threshold. When the IC_ENABLE bit 0 is 0, the TX FIFO is flushed and held in reset. There the TX FIFO looks like it has no data within it, so this bit is set to 1, provided there is activity in the master or slave state machines. When there is no longer activity, then with ic_en=0, this bit is set to 0.</p>	0x0
3	R	<p>TX_OVER</p> <p>Set during transmit if the transmit buffer is filled to 32 and the processor attempts to issue another I2C command by writing to the IC_DATA_CMD register. When the module is disabled, this bit keeps its level until the master or slave state machines go into idle, and when ic_en goes to 0, this interrupt is cleared .</p>	0x0
2	R	<p>RX_FULL</p> <p>Set when the receive buffer reaches or goes above the RX_TL threshold in the I2C_RX_TL register. It is automatically cleared by hardware when buffer level goes below the threshold. If the module is disabled (I2C_ENABLE[0]=0), the RX FIFO is flushed and held in reset; therefore the RX FIFO is not full. So this bit is cleared once the I2C_ENABLE bit 0 is programmed with a 0, regardless of the activity that continues.</p>	0x0
1	R	<p>RX_OVER</p> <p>Set if the receive buffer is completely filled to 32 and an additional byte is received from an external I2C device. The controller acknowledges this, but any data bytes received after the FIFO is full are lost. If the module is disabled (I2C_ENABLE[0]=0), this bit keeps its level until the master or slave state machines go into idle, and when ic_en goes to 0, this interrupt is cleared.</p>	0x0
0	R	<p>RX_UNDER</p> <p>Set if the processor attempts to read the receive buffer when it is empty by reading from the IC_DATA_CMD register. If the module is disabled (I2C_ENABLE[0]=0), this bit keeps its level until the master or slave state machines go into idle, and when ic_en goes to 0, this interrupt is cleared.</p>	0x0

Table 726: I2C_RX_TL_REG (0x50020638)

Bit	Mode	Symbol/Description	Reset
31:5	-	- Reserved	0x0
4:0	R/W	<p>RX_TL</p> <p>Receive FIFO Threshold Level Controls the level of entries (or above) that triggers the RX_FULL interrupt (bit 2 in I2C_RAW_INTR_STAT register). The valid range is 0-31, with the additional restriction that hardware does not allow this value to be set to a value larger than the depth of the buffer. If an attempt is made to do that, the actual value set will be the maximum depth of the buffer. A value of 0 sets the threshold for 1 entry, and a value of 31 sets the threshold for 32 entries.</p>	0x0

Table 727: I2C_TX_TL_REG (0x5002063C)

Bit	Mode	Symbol/Description	Reset
31:5	-	- Reserved	0x0

Bit	Mode	Symbol/Description	Reset
4:0	R/W	TX_TL Transmit FIFO Threshold Level Controls the level of entries (or below) that trigger the TX_EMPTY interrupt (bit 4 in I2C_RAW_INTR_STAT register). The valid range is 0-31, with the additional restriction that it may not be set to value larger than the depth of the buffer. If an attempt is made to do that, the actual value set will be the maximum depth of the buffer. A value of 0 sets the threshold for 0 entries, and a value of 31 sets the threshold for 32 entries.	0x0

Table 728: I2C_CLR_INTR_REG (0x50020640)

Bit	Mode	Symbol/Description	Reset
31:1	-	- Reserved	0x0
0	R	CLR_INTR Read this register to clear the combined interrupt, all individual interrupts, and the I2C_TX_ABRT_SOURCE register. This bit does not clear hardware clearable interrupts but software clearable interrupts. See Bit 9 of the I2C_TX_ABRT_SOURCE register for an exception to clearing I2C_TX_ABRT_SOURCE.	0x0

Table 729: I2C_CLR_RX_UNDER_REG (0x50020644)

Bit	Mode	Symbol/Description	Reset
31:1	-	- Reserved	0x0
0	R	CLR_RX_UNDER Read this register to clear the RX_UNDER interrupt (bit 0) of the I2C_RAW_INTR_STAT register.	0x0

Table 730: I2C_CLR_RX_OVER_REG (0x50020648)

Bit	Mode	Symbol/Description	Reset
31:1	-	- Reserved	0x0
0	R	CLR_RX_OVER Read this register to clear the RX_OVER interrupt (bit 1) of the I2C_RAW_INTR_STAT register.	0x0

Table 731: I2C_CLR_TX_OVER_REG (0x5002064C)

Bit	Mode	Symbol/Description	Reset
31:1	-	- Reserved	0x0
0	R	CLR_TX_OVER Read this register to clear the TX_OVER interrupt (bit 3) of the I2C_RAW_INTR_STAT register.	0x0

Table 732: I2C_CLR_RD_REQ_REG (0x50020650)

Bit	Mode	Symbol/Description	Reset
31:1	-	- Reserved	0x0
0	R	CLR_RD_REQ Read this register to clear the RD_REQ interrupt (bit 5) of the I2C_RAW_INTR_STAT register.	0x0

Table 733: I2C_CLR_TX_ABRT_REG (0x50020654)

Bit	Mode	Symbol/Description	Reset
31:1	-	- Reserved	0x0
0	R	CLR_TX_ABRT Read this register to clear the TX_ABRT interrupt (bit 6) of the IC_RAW_INTR_STAT register, and the I2C_TX_ABRT_SOURCE register. This also releases the TX FIFO from the flushed/reset state, allowing more writes to the TX FIFO. See Bit 9 of the I2C_TX_ABRT_SOURCE register for an exception to clearing IC_TX_ABRT_SOURCE.	0x0

Table 734: I2C_CLR_RX_DONE_REG (0x50020658)

Bit	Mode	Symbol/Description	Reset
31:1	-	- Reserved	0x0
0	R	CLR_RX_DONE Read this register to clear the RX_DONE interrupt (bit 7) of the I2C_RAW_INTR_STAT register.	0x0

Table 735: I2C_CLR_ACTIVITY_REG (0x5002065C)

Bit	Mode	Symbol/Description	Reset
31:1	-	- Reserved	0x0
0	R	CLR_ACTIVITY Reading this register clears the ACTIVITY interrupt if the I2C is not active anymore. If the I2C module is still active on the bus, the ACTIVITY interrupt bit continues to be set. It is automatically cleared by hardware if the module is disabled and if there is no further activity on the bus. The value read from this register to get status of the ACTIVITY interrupt (bit 8) of the IC_RAW_INTR_STAT register.	0x0

Table 736: I2C_CLR_STOP_DET_REG (0x50020660)

Bit	Mode	Symbol/Description	Reset
31:1	-	- Reserved	0x0
0	R	CLR_STOP_DET	0x0

Bit	Mode	Symbol/Description	Reset
		Read this register to clear the STOP_DET interrupt (bit 9) of the IC_RAW_INTR_STAT register.	

Table 737: I2C_CLR_START_DET_REG (0x50020664)

Bit	Mode	Symbol/Description	Reset
31:1	-	- Reserved	0x0
0	R	CLR_START_DET Read this register to clear the START_DET interrupt (bit 10) of the IC_RAW_INTR_STAT register.	0x0

Table 738: I2C_CLR_GEN_CALL_REG (0x50020668)

Bit	Mode	Symbol/Description	Reset
31:1	-	- Reserved	0x0
0	R	CLR_GEN_CALL Read this register to clear the GEN_CALL interrupt (bit 11) of I2C_RAW_INTR_STAT register.	0x0

Table 739: I2C_ENABLE_REG (0x5002066C)

Bit	Mode	Symbol/Description	Reset
31:3	-	- Reserved	0x0
2	R/W	I2C_TX_CMD_BLOCK In Master mode: 1 = Block the transmission of data on I2C bus even if TX FIFO has data to transmit. 0 = The transmission of data starts on I2C bus automatically as soon as the first data is available in the TX FIFO.	0x0
1	R/W	I2C_ABORT The software can abort the I2C transfer in master mode by setting this bit. The software can set this bit only when ENABLE is already set; otherwise, the controller ignores any write to ABORT bit. The software cannot clear the ABORT bit once set. In response to an ABORT, the controller issues a STOP and flushes the TX FIFO after completing the current transfer, then sets the TX_ABORT interrupt after the abort operation. The ABORT bit is cleared automatically after the abort operation.	0x0
0	R/W	I2C_EN Control whether the controller is enabled. 0 = Disable the controller (TX and RX FIFOs are held in an erased state) 1 = Enable the controller Software can disable the controller while it is active. However, it is important that care be taken to ensure that the controller is disabled properly. When the controller is disabled, the following occurs: * The TX FIFO and RX FIFO get flushed.	0x0

Bit	Mode	Symbol/Description	Reset
		<p>* Status bits in the IC_INTR_STAT register are still active until the controller goes into IDLE state.</p> <p>If the module is transmitting, it stops as well as deletes the contents of the transmit buffer after the current transfer is complete. If the module is receiving, the controller stops the current transfer at the end of the current byte and does not acknowledge the transfer.</p> <p>There is a two ic_clk delay when enabling or disabling the controller.</p>	

Table 740: I2C_STATUS_REG (0x50020670)

Bit	Mode	Symbol/Description	Reset
31:11	-	- Reserved	0x0
10	R	<p>LV_HOLD_RX_FIFO_FULL</p> <p>This bit indicates the BUS Hold in Slave mode due to RX FIFO is Full and an additional byte has been received.</p> <p>1 = Slave holds the bus due to Rx FIFO is full.</p> <p>0 = Slave is not holding the bus or Bus hold is not due to Rx FIFO is full.</p>	0x0
9	R	<p>SLV_HOLD_TX_FIFO_EMPTY</p> <p>This bit indicates the BUS Hold in Slave mode for the Read request when the TX FIFO is empty. The Bus is in hold until the TX FIFO has data to Transmit for the read request.</p> <p>1 = Slave holds the bus due to TX FIFO is empty.</p> <p>0 = Slave is not holding the bus or Bus hold is not due to TX FIFO is empty.</p>	0x0
8	R	<p>MST_HOLD_RX_FIFO_FULL</p> <p>This bit indicates the BUS Hold in Master mode due to RX FIFO is Full and additional byte is received.</p> <p>1 = Master holds the bus due to RX FIFO is full.</p> <p>0 = Master is not holding the bus or Bus hold is not due to RX FIFO is full.</p>	0x0
7	R	<p>MST_HOLD_TX_FIFO_EMPTY</p> <p>The DW_apb_i2c master stalls the write transfer when TX FIFO is empty, and the the last byte does not have the Stop bit set. This bit indicates the BUS hold when the master holds the bus because of the TX FIFO being empty, and the the previous transferred command does not have the Stop bit set.</p> <p>1 = Master holds the bus due to TX FIFO is empty.</p> <p>0 = Master is not holding the bus or Bus hold is not due to TX FIFO is empty.</p>	0x0
6	R	<p>SLV_ACTIVITY</p> <p>Slave FSM Activity Status. When the Slave Finite State Machine (FSM) is not in the IDLE state, this bit is set.</p> <p>0 = Slave FSM is in IDLE state so the Slave part of the controller is not Active.</p> <p>1 = Slave FSM is not in IDLE state so the Slave part of the controller is Active.</p>	0x0
5	R	<p>MST_ACTIVITY</p> <p>Master FSM Activity Status. When the Master Finite State Machine (FSM) is not in the IDLE state, this bit is set.</p> <p>0 = Master FSM is in IDLE state so the Master part of the controller is not Active.</p> <p>1 = Master FSM is not in IDLE state so the Master part of the controller is Active.</p>	0x0
4	R	RFF	0x0

Bit	Mode	Symbol/Description	Reset
		Receive FIFO Completely Full. When the receive FIFO is completely full, this bit is set. When the receive FIFO contains one or more empty location, this bit is cleared. 0 = Receive FIFO is not full. 1 = Receive FIFO is full.	
3	R	RFNE Receive FIFO Not Empty. This bit is set when the receive FIFO contains one or more entries; it is cleared when the receive FIFO is empty. 0 = Receive FIFO is empty. 1 = Receive FIFO is not empty.	0x0
2	R	TFE Transmit FIFO Completely Empty. When the transmit FIFO is completely empty, this bit is set. When it contains one or more valid entries, this bit is cleared. This bit field does not request an interrupt. 0 = Transmit FIFO is not empty. 1 = Transmit FIFO is empty.	0x1
1	R	TFNF Transmit FIFO Not Full. Set when the transmit FIFO contains one or more empty locations, and is cleared when the FIFO is full. 0 = Transmit FIFO is full. 1 = Transmit FIFO is not full.	0x1
0	R	I2C_ACTIVITY I2C Activity Status.	0x0

Table 741: I2C_TXFLR_REG (0x50020674)

Bit	Mode	Symbol/Description	Reset
31:6	-	- Reserved	0x0
5:0	R	TXFLR Transmit FIFO Level. Contain the number of valid data entries in the transmit FIFO. Size is constrained by the TXFLR value.	0x0

Table 742: I2C_RXFLR_REG (0x50020678)

Bit	Mode	Symbol/Description	Reset
31:6	-	- Reserved	0x0
5:0	R	RXFLR Receive FIFO Level. Contain the number of valid data entries in the receive FIFO. Size is constrained by the RXFLR value.	0x0

Table 743: I2C_SDA_HOLD_REG (0x5002067C)

Bit	Mode	Symbol/Description	Reset
23:16	R/W	I2C_SDA_RX_HOLD Set the required SDA hold time in units of ic_clk period when receiving.	0x0

Bit	Mode	Symbol/Description	Reset
15:0	R/W	I2C_SDA_TX_HOLD Set the required SDA hold time in units of ic_clk period when transmitting.	0x1

Table 744: I2C_TX_ABRT_SOURCE_REG (0x50020680)

Bit	Mode	Symbol/Description	Reset
16	R	ABRT_USER_ABRT Master-Transmitter: This is a master-mode-only bit. Master has detected the transfer abort (IC_ENABLE[1]).	0x0
15	R	ABRT_SLVRD_INTX Slave-Transmitter: When the processor side responds to a slave mode request for data to be transmitted to a remote master and a user writes a 1 in CMD (bit 8) of I2C_DATA_CMD register. 1 = Slave trying to transmit to remote master in read mode. 0 = Slave trying to transmit to remote master in read mode- scenario not present.	0x0
14	R	ABRT_SLV_ARBLOST Slave-Transmitter: Slave lost the bus while transmitting data to a remote master. I2C_TX_ABRT_SOURCE[12] is set at the same time. Note: Even though the slave never "owns" the bus, something could go wrong on the bus. This is a fail safe check. For instance, during a data transmission at the low-to-high transition of SCL, if what is on the data bus is not what is supposed to be transmitted, then the controller no longer own the bus. 1 = Slave lost arbitration to remote master. 0 = Slave lost arbitration to remote master- scenario not present.	0x0
13	R	ABRT_SLVFLUSH_TXFIFO Slave-Transmitter: Slave has received a read command and some data exists in the TX FIFO so the slave issues a TX_ABRT interrupt to flush old data in TX FIFO. 1 = Slave flushes existing data in TX-FIFO upon getting read command. 0 = Slave flushes existing data in TX-FIFO upon getting read command- scenario not present.	0x0
12	R	ARB_LOST Master-Transmitter or Slave-Transmitter: Master has lost arbitration, or if I2C_TX_ABRT_SOURCE[14] is also set, then the slave transmitter has lost arbitration. Note: I2C can be both master and slave at the same time. 1 = Master or Slave-Transmitter lost arbitration. 0 = Master or Slave-Transmitter lost arbitration- scenario not present.	0x0
11	R	ABRT_MASTER_DIS Master-Transmitter or Master-Receiver: User tries to initiate a Master operation with the Master mode disabled. 1 = User initiating master operation when MASTER disable. 0 = User initiating master operation when MASTER disabled- scenario not present.	0x0
10	R	ABRT_10B_RD_NORSTR Master-Receiver: The restart is disabled (IC_RESTART_EN bit (I2C_CON[5]) = 0) and the master sends a read command in 10-bit addressing mode. 1 = Master trying to read in 10-bit addressing mode when RESTART disabled. 0 = Master not trying to read in 10-bit addressing mode when RESTART disabled.	0x0
9	R	ABRT_SBYTE_NORSTR	0x0

Bit	Mode	Symbol/Description	Reset
		<p>Master: To clear Bit 9, the source of the ABRT_SBYTE_NORSTRT must be fixed first; restart must be enabled (I2C_CON[5]=1), the SPECIAL bit must be cleared (I2C_TAR[11]), or the GC_OR_START bit must be cleared (I2C_TAR[10]). Once the source of the ABRT_SBYTE_NORSTRT is fixed, then this bit can be cleared in the same manner as other bits in this register. If the source of the ABRT_SBYTE_NORSTRT is not fixed before attempting to clear this bit, bit 9 clears for one cycle and then gets re-asserted. 1: The restart is disabled (IC_RESTART_EN bit (I2C_CON[5]) = 0) and the user is trying to send a START Byte.</p> <p>1 = User trying to send START byte when RESTART disabled. 0 = User trying to send START byte when RESTART disabled- scenario not present.</p>	
8	R	<p>ABRT_HS_NORSTRT</p> <p>Master-Transmitter or Master-Receiver: The restart is disabled (IC_RESTART_EN bit (I2C_CON[5]) = 0) and the user is trying to use the master to transfer data in High Speed mode.</p> <p>1 = User trying to switch Master to HS mode when RESTART disabled. 0 = User trying to switch Master to HS mode when RESTART disabled- scenario not present.</p>	0x0
7	R	<p>ABRT_SBYTE_ACKDET</p> <p>Master: Master has sent a START Byte and the START Byte was acknowledged (wrong behavior).</p> <p>1 = ACK detected for START byte. 0 = ACK detected for START byte- scenario not present.</p>	0x0
6	R	<p>ABRT_HS_ACKDET</p> <p>Master: Master is in High Speed mode and the High Speed Master code was acknowledged (wrong behavior).</p> <p>1 = HS Master code ACKed in HS Mode. 0 = HS Master code ACKed in HS Mode- scenario not present.</p>	0x0
5	R	<p>ABRT_GCALL_READ</p> <p>Master-Transmitter: The controller in master mode sent a General Call but the user programmed the byte following the General Call to be a read from the bus (IC_DATA_CMD[9] is set to 1).</p> <p>1 = GCALL is followed by read from bus. 0 = GCALL is followed by read from bus-scenario not present.</p>	0x0
4	R	<p>ABRT_GCALL_NOACK</p> <p>Master-Transmitter: The controller in master mode sent a General Call and no slave on the bus acknowledged the General Call.</p> <p>1 = GCALL not ACKed by any slave. 0 = GCALL not ACKed by any slave-scenario not present.</p>	0x0
3	R	<p>ABRT_TXDATA_NOACK</p> <p>Master-Transmitter: This is a master-mode only bit. Master has received an acknowledgement for the address, but when it sent data byte(s) following the address, it did not receive an acknowledge from the remote slave(s).</p> <p>1 = Transmitted data not ACKed by addressed slave. 0 = Transmitted data non-ACKed by addressed slave-scenario not present.</p>	0x0
2	R	<p>ABRT_10ADDR2_NOACK</p> <p>Master-Transmitter or Master-Receiver: Master is in 10-bit address mode and the second address byte of the 10-bit address was not acknowledged by any slave.</p> <p>1 = Byte 2 of 10-bit address not ACKed by any slave.</p>	0x0

Bit	Mode	Symbol/Description	Reset
		0 = This abort is not generated.	
1	R	ABRT_10ADDR1_NOACK Master-Transmitter or Master-Receiver: Master is in 10-bit address mode and the first 10-bit address byte was not acknowledged by any slave. 1 = Byte 1 of 10-bit address not ACKed by any slave. 0 = This abort is not generated.	0x0
0	R	ABRT_7B_ADDR_NOACK Master-Transmitter or Master-Receiver: Master is in 7-bit addressing mode and the address sent was not acknowledged by any slave. 1 = This abort is generated because of NOACK for 7-bit address. 0 = This abort is not generated.	0x0

Table 745: **I2C_DMA_CR_REG (0x50020688)**

Bit	Mode	Symbol/Description	Reset
1	R/W	TDMAE Transmit DMA Enable. This bit enables/disables the transmit FIFO DMA channel. 0 = Transmit DMA disabled. 1 = Transmit DMA enabled.	0x0
0	R/W	RDMAE Receive DMA Enable. This bit enables/disables the receive FIFO DMA channel. 0 = Receive DMA disabled. 1 = Receive DMA enabled.	0x0

Table 746: **I2C_DMA_TDLR_REG (0x5002068C)**

Bit	Mode	Symbol/Description	Reset
4:0	R/W	DMATDL Transmit Data Level. This bit field controls the level at which a DMA request is made by the transmit logic. It is equal to the watermark level; that is, the dma_tx_req signal is generated when the number of valid data entries in the transmit FIFO is equal to or below this field value, and TDMAE = 1.	0x0

Table 747: **I2C_DMA_RDLR_REG (0x50020690)**

Bit	Mode	Symbol/Description	Reset
4:0	R/W	DMARDL Receive Data Level. This bit field controls the level at which a DMA request is made by the receive logic. The watermark level = DMARDL+1; that is, dma_rx_req is generated when the number of valid data entries in the receive FIFO is equal to or more than this field value + 1, and RDMAE = 1. For instance, when DMARDL is 0, then dma_rx_req is asserted when 1 or more data entries are present in the receive FIFO.	0x0

Table 748: **I2C_SDA_SETUP_REG (0x50020694)**

Bit	Mode	Symbol/Description	Reset
15:8	-	- Reserved	0x0

Bit	Mode	Symbol/Description	Reset
7:0	R/W	<p>SDA_SETUP</p> <p>SDA Setup.</p> <p>This register controls the amount of time delay (number of I2C clock periods) between the rising edge of SCL and SDA changing by holding SCL low when I2C block services a read request while operating as a slave-transmitter. The relevant I2C requirement is t_{SU:DAT} (note 4) as detailed in the I2C Bus Specification. This register must be programmed with a value equal to or greater than 2.</p> <p>It is recommended that if the required delay is 1000 ns, then for an I2C frequency of 10 MHz, IC_SDA_SETUP should be programmed to a value of 11. Write to this register succeed only when IC_ENABLE[0] = 0.</p>	0x64

Table 749: I2C_ACK_GENERAL_CALL_REG (0x50020698)

Bit	Mode	Symbol/Description	Reset
15:1	-	- Reserved	0x0
0	R/W	<p>ACK_GEN_CALL</p> <p>ACK General Call. When set to 1, I2C Ctrl responds with a ACK (by asserting ic_data_oe) when it receives a General Call. When set to 0, the controller does not generate General Call interrupts.</p> <p>1 = Generate ACK for a General Call. 0 = Generate NACK for General Call.</p>	0x0

Table 750: I2C_ENABLE_STATUS_REG (0x5002069C)

Bit	Mode	Symbol/Description	Reset
15:3	-	- Reserved	0x0
2	R	<p>SLV_RX_DATA_LOST</p> <p>Slave Received Data Lost. This bit indicates if a Slave-Receiver operation is aborted with at least one data byte received from an I2C transfer due to the setting of IC_ENABLE from 1 to 0. When read as 1, the controller is deemed to have actively engaged in an aborted I2C transfer (with matching address) and the data phase of the I2C transfer is entered, even though a data byte is responded with a NACK. NOTE: If the remote I2C master terminates the transfer with a STOP condition before the controller has a chance to NACK a transfer, and IC_ENABLE is set to 0, then this bit is also set to 1. When read as 0, the controller is deemed to have disabled without being actively involved in the data phase of a Slave-Receiver transfer.</p> <p>NOTE: The CPU can safely read this bit when IC_EN (bit 0) is read as 0.</p> <p>1 = Slave RX Data is lost. 0 = Slave RX Data is not lost.</p>	0x0
1	R	<p>SLV_DISABLED_WHILE_BUSY</p> <p>Slave Disabled While Busy (Transmit, Receive). This bit indicates if a potential or active Slave operation has aborted due to the setting of the IC_ENABLE register from 1 to 0. This bit is set when the CPU writes a 0 to the IC_ENABLE register while:</p> <p>(a) I2C Ctrl is receiving the address byte of the Slave-Transmitter operation from a remote master; OR,</p> <p>(b) address and data bytes of the Slave-Receiver operation from a remote master.</p> <p>When read as 1, the controller is deemed to have forced a NACK during any part of an I2C transfer, irrespective of whether the I2C address matches the slave</p>	0x0

Bit	Mode	Symbol/Description	Reset
		<p>address set in I2C Ctrl (IC_SAR register) OR if the transfer is completed before IC_ENABLE is set to 0, but has not taken effect.</p> <p>NOTE: If the remote I2C master terminates the transfer with a STOP condition before the the controller has a chance to NACK a transfer, and IC_ENABLE is set to 0, then this bit is also set to 1.</p> <p>When read as 0, the controller is deemed to be disabled when there is master activity, or when the I2C bus is idle.</p> <p>NOTE: The CPU can safely read this bit when IC_EN (bit 0) is read as 0.</p> <p>1 = Slave is disabled when it is active.</p> <p>0 = Slave is disabled when it is idle.</p>	
0	R	<p>IC_EN</p> <p>ic_en Status. This bit always reflects the value driven on the output port ic_en. When read as 1, the controller is deemed to be in an enabled state.</p> <p>When read as 0, the controller is deemed completely inactive.</p> <p>NOTE: The CPU can safely read this bit anytime. When this bit is read as 0, the CPU can safely read SLV_RX_DATA_LOST (bit 2) and SLV_DISABLED_WHILE_BUSY (bit 1).</p> <p>1 = I2C enabled.</p> <p>0 = I2C disabled.</p>	0x0

Table 751: I2C_IC_FS_SPKLEN_REG (0x500206A0)

Bit	Mode	Symbol/Description	Reset
15:8	-	- Reserved	0x0
7:0	R/W	<p>I2C_FS_SPKLEN</p> <p>This register must be set before any I2C bus transaction can take place to ensure stable operation. This register sets the duration, measured in ic_clk cycles, of the longest spike in the SCL or SDA lines that are filtered out by the spike suppression logic. This register can be written only when the I2C interface is disabled which corresponds to the IC_ENABLE register being set to 0. Write at other times have no effect. The minimum valid value is 1; hardware prevents values less than this being written, and if attempted results in 1 being set.</p>	0x1

Table 752: I2C_IC_HS_SPKLEN_REG (0x500206A4)

Bit	Mode	Symbol/Description	Reset
7:0	R/W	<p>I2C_HS_SPKLEN</p> <p>This register must be set before any I2C bus transaction can take place to ensure stable operation. This register sets the duration, measured in ic_clk cycles, of the longest spike in the SCL or SDA lines that are filtered out by the spike suppression logic. This register can be written only when the I2C interface is disabled which corresponds to the IC_ENABLE[0] register being set to 0. Write at other times have no effect.</p> <p>The minimum valid value is 1; hardware prevents values less than this being written, and if attempted results in 1 being set.</p>	0x1

Table 753: I2C2_CON_REG (0x50020700)

Bit	Mode	Symbol/Description	Reset
31:11	-	-	0x0

Bit	Mode	Symbol/Description	Reset
		Reserved	
10	R	I2C_STOP_DET_IF_MASTER_ACTIVE In Master mode: 1 = Issue the STOP_DET interrupt only when master is active. 0 = Issue the STOP_DET irrespective of whether master is active or not.	0x0
9	R/W	I2C_RX_FIFO_FULL_HLD_CTRL This bit controls whether DW_apb_i2c should hold the bus when the RX FIFO is physically full to its RX_BUFFER_DEPTH. 1 = Hold bus when RX_FIFO is full. 0 = Overflow when RX_FIFO is full.	0x0
8	R/W	I2C_TX_EMPTY_CTRL This bit controls the generation of the TX_EMPTY interrupt as described in the IC_RAW_INTR_STAT register. 1 = Controlled generation of TX_EMPTY interrupt. 0 = Default behaviour of TX_EMPTY interrupt.	0x0
7	R/W	I2C_STOP_DET_IFADDRESSED 1 = Slave issues STOP_DET intr only if addressed. 0 = Slave issues STOP_DET intr always. During a general call address, this slave does not issue the STOP_DET interrupt if STOP_DET_IF_ADDRESSED = 1'b1, even if the slave responds to the general call address by generating ACK. The STOP_DET interrupt is generated only when the transmitted address matches the slave address (SAR).	0x0
6	R/W	I2C_SLAVE_DISABLE Slave enabled or disabled after reset is applied, which means software does not have to configure the slave. 0 = Slave is enabled. 1 = Slave is disabled. Software should ensure that if this bit is written with '0', then bit 0 should also be written with a '0'.	0x1
5	R/W	I2C_RESTART_EN Determine whether RESTART conditions may be sent when acting as a master. 0 = Disable 1 = Enable	0x1
4	R/W	I2C_10BITADDR_MASTER Control whether the controller starts its transfers in 7- or 10-bit addressing mode when acting as a master. 0 = 7-bit addressing 1 = 10-bit addressing	0x1
3	R/W	I2C_10BITADDR_SLAVE When acting as a slave, this bit controls whether the controller responds to 7- or 10-bit addresses. 0 = 7-bit addressing 1 = 10-bit addressing	0x1
2:1	R/W	I2C_SPEED These bits control at which speed the controller operates. 1 = Standard mode (100 kbit/s) 2 = Fast mode (400 kbit/s)	0x3

Bit	Mode	Symbol/Description	Reset
		3 = High speed mode	
0	R/W	I2C_MASTER_MODE This bit controls whether the controller master is enabled. 0 = Master disabled 1 = Master enabled Software should ensure that if this bit is written with '1' then bit 6 should also be written with a '1'.	0x1

Table 754: I2C2_TAR_REG (0x50020704)

Bit	Mode	Symbol/Description	Reset
31:12	-	- Reserved	0x0
11	R/W	SPECIAL On read This bit indicates whether software performs a General Call or START BYTE command. 0 = Ignore bit 10 GC_OR_START and use IC_TAR normally. 1 = Perform special I2C command as specified in GC_OR_START bit. On write 1 = Enables programming of GENERAL_CALL or START_BYTE transmission. 0 = Disables programming of GENERAL_CALL or START_BYTE transmission. Write to this register succeed only when IC_ENABLE[0] is set to 0.	0x0
10	R/W	GC_OR_START On read If bit 11 (SPECIAL) is set to 1, then this bit indicates whether a General Call or START byte command is to be performed by the controller. 0 = General Call Address - after issuing a General Call, only writes may be performed. Attempting to issue a read command results in setting bit 6 (TX_ABRT) of the IC_RAW_INTR_STAT register. The controller remains in General Call mode until the SPECIAL bit value (bit 11) is cleared. 1 = START BYTE On write 1 = START byte transmission 0 = GENERAL_CALL byte transmission Write to this register succeed only when IC_ENABLE[0] is set to 0.	0x0
9:0	R/W	IC_TAR This is the target address for any master transaction. When transmitting a General Call, these bits are ignored. To generate a START BYTE, the CPU needs to write only once into these bits. Note: If the IC_TAR and IC_SAR are the same, loopback exists but the FIFOs are shared between master and slave, so full loopback is not feasible. Only one direction loopback mode is supported (simplex), not duplex. A master cannot transmit to itself; it can transmit to only a slave. Write to this register succeed only when IC_ENABLE[0] is set to 0.	0x55

Table 755: I2C2_SAR_REG (0x50020708)

Bit	Mode	Symbol/Description	Reset
31:10	-	- Reserved	0x0
9:0	R/W	IC_SAR The IC_SAR holds the slave address when the I2C is operating as a slave. For 7-bit addressing, only IC_SAR[6:0] is used. This register can be written only when the I2C interface is disabled, which corresponds to the IC_ENABLE register being set to 0. Write at other times have no effect. Write to this register succeed only when IC_ENABLE[0] is set to 0.	0x55

Table 756: I2C2_HS_MADDR_REG (0x5002070C)

Bit	Mode	Symbol/Description	Reset
2:0	R/W	I2C_IC_HS_MAR This bit field holds the value of the I2C HS mode master code. HS-mode master codes are reserved 8-bit codes (00001xxx) that are not used for slave addressing or other purposes. Each master has its unique master code; up to eight high-speed mode masters can be present on the same I2C bus system. Valid values are from 0 to 7. This register can be written only when the I2C interface is disabled, which corresponds to the IC_ENABLE[0] register being set to 0. Write at other times have no effect.	0x1

Table 757: I2C2_DATA_CMD_REG (0x50020710)

Bit	Mode	Symbol/Description	Reset
30:11	-	- Reserved	0x0
10	W	I2C_RESTART This bit controls whether a RESTART is issued before the byte is sent or received. 1 = If IC_RESTART_EN is 1, a RESTART is issued before the data is sent/received (according to the value of CMD), regardless of whether or not the transfer direction is changing from the previous command; if IC_RESTART_EN is 0, a STOP followed by a START is issued instead. 0 = If IC_RESTART_EN is 1, a RESTART is issued only if the transfer direction is changing from the previous command; if IC_RESTART_EN is 0, a STOP followed by a START is issued instead.	0x0
9	W	I2C_STOP This bit controls whether a STOP is issued after the byte is sent or received. 1 = STOP is issued after this byte, regardless of whether or not the TX FIFO is empty. If the TX FIFO is not empty, the master immediately tries to start a new transfer by issuing a START and arbitrating for the bus. 0 = STOP is not issued after this byte, regardless of whether or not the TX FIFO is empty. If the TX FIFO is not empty, the master continues the current transfer by sending/receiving data bytes according to the value of the CMD bit. If the TX FIFO is empty, the master holds the SCL line low and stalls the bus until a new command is available in the TX FIFO.	0x0
8	W	I2C_CMD This bit controls whether a read or a write is performed. This bit does not control the direction when the I2C Ctrl acts as a slave. It controls only the direction when it acts as a master. 1 = Read	0x0

Bit	Mode	Symbol/Description	Reset
		<p>0 = Write</p> <p>When a command is entered in the TX FIFO, this bit distinguishes the write and read commands. In slave-receiver mode, this bit is a "don't care" because writes to this register are not required. In slave-transmitter mode, a "0" indicates that CPU data is to be transmitted and as DAT or IC_DATA_CMD[7:0]. When programming this bit, you should remember the following: attempting to perform a read operation after a General Call command has been sent results in a TX_ABRT interrupt (bit 6 of the I2C_RAW_INTR_STAT_REG), unless bit 11 (SPECIAL) in the I2C_TAR register has been cleared.</p> <p>If a "1" is written to this bit after receiving a RD_REQ interrupt, then a TX_ABRT interrupt occurs.</p> <p>NOTE: It is possible that while attempting a master I2C read transfer on the controller, a RD_REQ interrupt may have occurred simultaneously due to a remote I2C master addressing the controller. In this type of scenario, it ignores the I2C_DATA_CMD write, generates a TX_ABRT interrupt, and waits to service the RD_REQ interrupt.</p>	
7:0	R/W	<p>I2C_DAT</p> <p>This register contains the data to be transmitted or received on the I2C bus. If you are writing to this register and want to perform a read, bits 7:0 (DAT) are ignored by the controller. However, when you read this register, these bits return the value of data received on the controller's interface.</p>	0x0

Table 758: I2C2_SS_SCL_HCNT_REG (0x50020714)

Bit	Mode	Symbol/Description	Reset
15:0	R/W	<p>IC_SS_SCL_HCNT</p> <p>This register must be set before any I2C bus transaction can take place to ensure proper I/O timing. This register sets the SCL clock high-period count for standard speed. This register can be written only when the I2C interface is disabled which corresponds to the IC_ENABLE register being set to 0. Write at other times have no effect.</p> <p>The minimum valid value is 6; hardware prevents values less than this being written, and if attempted results in 6 being set.</p> <p>NOTE: This register must not be programmed to a value higher than 65525, because the controller uses a 16-bit counter to flag an I2C bus idle condition when this counter reaches a value of IC_SS_SCL_HCNT + 10.</p>	0x91

Table 759: I2C2_SS_SCL_LCNT_REG (0x50020718)

Bit	Mode	Symbol/Description	Reset
15:0	R/W	<p>IC_SS_SCL_LCNT</p> <p>This register must be set before any I2C bus transaction can take place to ensure proper I/O timing. This register sets the SCL clock low period count for standard speed.</p> <p>This register can be written only when the I2C interface is disabled which corresponds to the I2C_ENABLE register being set to 0. Write at other times have no effect.</p> <p>The minimum valid value is 8; hardware prevents values less than this being written, and if attempted, results in 8 being set.</p>	0xAB

Table 760: I2C2_FS_SCL_HCNT_REG (0x5002071C)

Bit	Mode	Symbol/Description	Reset
15:0	R/W	<p>IC_FS_SCL_HCNT</p> <p>This register must be set before any I2C bus transaction can take place to ensure proper I/O timing. This register sets the SCL clock high-period count for fast speed. It is used in high-speed mode to send the Master Code and START BYTE or General CALL. This register can be written only when the I2C interface is disabled, which corresponds to the I2C_ENABLE register being set to 0. Writes at other times have no effect.</p> <p>The minimum valid value is 6; hardware prevents values less than this being written, and if attempted results in 6 being set.</p>	0x1A

Table 761: I2C2_FS_SCL_LCNT_REG (0x50020720)

Bit	Mode	Symbol/Description	Reset
15:0	R/W	<p>IC_FS_SCL_LCNT</p> <p>This register must be set before any I2C bus transaction can take place to ensure proper I/O timing. This register sets the SCL clock low-period count for fast speed. It is used in high-speed mode to send the Master Code and START BYTE or General CALL. This register can be written only when the I2C interface is disabled, which corresponds to the I2C_ENABLE register being set to 0. Write at other times have no effect.</p> <p>The minimum valid value is 8; hardware prevents values less than this being written, and if attempted results in 8 being set. For designs with APB_DATA_WIDTH = 8, the order of programming is important to ensure the correct operation of the controller. The lower byte must be programmed first. Then the upper byte is programmed.</p>	0x32

Table 762: I2C2_HS_SCL_HCNT_REG (0x50020724)

Bit	Mode	Symbol/Description	Reset
15:0	R/W	<p>IC_HS_SCL_HCNT</p> <p>This register must be set before any I2C bus transaction can take place to ensure proper I/O timing. This register sets the SCL clock high period count for high speed. See "IC_CLK Frequency Configuration".</p> <p>The SCL High time depends on the loading of the bus. For 100 pF loading, the SCL High time is 60 ns; for 400 pF loading, the SCL High time is 120 ns. This register goes away and becomes read-only returning 0s if IC_MAX_SPEED_MODE != high.</p> <p>This register can be written only when the I2C interface is disabled, which corresponds to the IC_ENABLE[0] register being set to 0. Write at other times have no effect.</p> <p>The minimum valid value is 6; hardware prevents values less than this being written, and if attempted results in 6 being set. For designs with APB_DATA_WIDTH = 8, the order of programming is important to ensure the correct operation of the DW_apb_i2c. The lower byte must be programmed first. Then the upper byte is programmed.</p>	0x6

Table 763: I2C2_HS_SCL_LCNT_REG (0x50020728)

Bit	Mode	Symbol/Description	Reset
15:0	R/W	IC_HS_SCL_LCNT	0x10

Bit	Mode	Symbol/Description	Reset
		<p>This register must be set before any I2C bus transaction can take place to ensure proper I/O timing. This register sets the SCL clock low period count for high speed. For more information, see "IC_CLK Frequency Configuration".</p> <p>The SCL low time depends on the loading of the bus. For 100 pF loading, the SCL low time is 160 ns; for 400 pF loading, the SCL low time is 320 ns. This register goes away and becomes read-only returning 0s if IC_MAX_SPEED_MODE != high.</p> <p>This register can be written only when the I2C interface is disabled, which corresponds to the IC_ENABLE[0] register being set to 0. Write at other times have no effect.</p> <p>The minimum valid value is 8; hardware prevents values less than this being written, and if attempted results in 8 being set. For designs with APB_DATA_WIDTH == 8, the order of programming is important to ensure the correct operation of the DW_apb_i2c. The lower byte must be programmed first. Then the upper byte is programmed. If the value is less than 8 then the count value gets changed to 8.</p>	

Table 764: I2C2_INTR_STAT_REG (0x5002072C)

Bit	Mode	Symbol/Description	Reset
31:15	-	- Reserved	0x0
14	R	R_SCL_STUCK_AT_LOW 1 = R_SCL_STUCK_AT_LOW interrupt is active. 0 = R_SCL_STUCK_AT_LOW interrupt is inactive.	0x0
13	R	R_MASTER_ON_HOLD Indicate whether master is holding the bus and TX FIFO is empty. Enabled only when I2C_DYNAMIC_TAR_UPDATE=1 and IC_EMPTYFIFO_HOLD_MASTER_EN=1.	0x0
12	R	R_RESTART_DET Indicate whether a RESTART condition has occurred on the I2C interface when DW_apb_i2c is operating in Slave mode and the slave is being addressed. Enabled only when IC_SLV_RESTART_DET_EN=1. Note: However, in high-speed mode or during a START BYTE transfer, the RESTART comes before the address field as per the I2C protocol. In this case, the slave is not the addressed slave when the RESTART is issued, therefore DW_apb_i2c does not generate the RESTART_DET interrupt.	0x0
11	R	R_GEN_CALL Set only when a General Call address is received and it is acknowledged. It stays set until it is cleared either by disabling controller or when the CPU reads bit 0 of the I2C_CLR_GEN_CALL register. The controller stores the received data in the RX buffer.	0x0
10	R	R_START_DET Indicate whether a START or RESTART condition has occurred on the I2C interface regardless of whether controller is operating in slave or master mode.	0x0
9	R	R_STOP_DET Indicate whether a STOP condition has occurred on the I2C interface regardless of whether controller is operating in slave or master mode.	0x0
8	R	R_ACTIVITY	0x0

Bit	Mode	Symbol/Description	Reset
		<p>This bit captures I2C Ctrl activity and stays set until it is cleared. There are four ways to clear it:</p> <ul style="list-style-type: none"> => Disabling the I2C Ctrl => Reading the IC_CLR_ACTIVITY register => Reading the IC_CLR_INTR register => System reset <p>Once this bit is set, it stays set unless one of the four methods is used to clear it. Even if the controller module is idle, this bit remains set until cleared, indicating that there was activity on the bus.</p>	
7	R	<p>R_RX_DONE</p> <p>When the controller is acting as a slave-transmitter, this bit is set to 1 if the master does not acknowledge a transmitted byte. This occurs on the last byte of the transmission, indicating that the transmission is done.</p>	0x0
6	R	<p>R_TX_ABORT</p> <p>This bit indicates if the controller, as an I2C transmitter, is unable to complete the intended actions on the contents of the transmit FIFO. This situation can occur both as an I2C master or an I2C slave, and is referred to as a "transmit abort". When this bit is set to 1, the I2C_TX_ABORT_SOURCE register indicates the reason why the transmit abort takes places.</p> <p>NOTE: The controller flushes/resets/empties the TX FIFO whenever this bit is set. The TX FIFO remains in this flushed state until the register I2C_CLR_TX_ABORT is read. Once this read is performed, the TX FIFO is then ready to accept more data bytes from the APB interface.</p>	0x0
5	R	<p>R_RD_REQ</p> <p>This bit is set to 1 when the controller is acting as a slave and another I2C master is attempting to read data from the controller. The controller holds the I2C bus in a wait state (SCL=0) until this interrupt is serviced, which means that the slave has been addressed by a remote master that is asking for data to be transferred. The processor must respond to this interrupt and then write the requested data to the I2C_DATA_CMD register. This bit is set to 0 just after the processor reads the I2C_CLR_RD_REQ register.</p>	0x0
4	R	<p>R_TX_EMPTY</p> <p>This bit is set to 1 when the transmit buffer is at or below the threshold value set in the I2C_TX_TL register. It is automatically cleared by hardware when the buffer level goes above the threshold. When the IC_ENABLE bit 0 is 0, the TX FIFO is flushed and held in reset. There the TX FIFO looks like it has no data within it, so this bit is set to 1, provided there is activity in the master or slave state machines. When there is no longer activity, then with ic_en=0, this bit is set to 0.</p>	0x0
3	R	<p>R_TX_OVER</p> <p>Set during transmit if the transmit buffer is filled to 32 and the processor attempts to issue another I2C command by writing to the IC_DATA_CMD register. When the module is disabled, this bit keeps its level until the master or slave state machines go into idle, and when ic_en goes to 0, this interrupt is cleared</p>	0x0
2	R	<p>R_RX_FULL</p> <p>Set when the receive buffer reaches or goes above the RX_TL threshold in the I2C_RX_TL register. It is automatically cleared by hardware when buffer level goes below the threshold. If the module is disabled (I2C_ENABLE[0]=0), the RX FIFO is flushed and held in reset; therefore the RX FIFO is not full. So this bit is cleared once, the I2C_ENABLE bit 0 is programmed with a 0 regardless of the activity that continues.</p>	0x0
1	R	<p>R_RX_OVER</p>	0x0

Bit	Mode	Symbol/Description	Reset
		Set if the receive buffer is completely filled to 32 and an additional byte is received from an external I2C device. The controller acknowledges this, but any data bytes received after the FIFO is full are lost. If the module is disabled (I2C_ENABLE[0]=0), this bit keeps its level until the master or slave state machines go into idle, and when ic_en goes to 0, this interrupt is cleared.	
0	R	R_RX_UNDER Set if the processor attempts to read the receive buffer when it is empty by reading from the IC_DATA_CMD register. If the module is disabled (I2C_ENABLE[0]=0), this bit keeps its level until the master or slave state machines go into idle, and when ic_en goes to 0, this interrupt is cleared.	0x0

Table 765: I2C2_INTR_MASK_REG (0x50020730)

Bit	Mode	Symbol/Description	Reset
31:15	-	- Reserved	0x0
14	R	M_SCL_STUCK_AT_LOW M_SCL_STUCK_AT_LOW Register field Reserved bits.	0x0
13	R/W	M_MASTER_ON_HOLD These bits mask their corresponding interrupt status bits in the I2C_INTR_STAT register.	0x0
12	R/W	M_RESTART_DET These bits mask their corresponding interrupt status bits in the I2C_INTR_STAT register.	0x0
11	R/W	M_GEN_CALL These bits mask their corresponding interrupt status bits in the I2C_INTR_STAT register.	0x1
10	R/W	M_START_DET These bits mask their corresponding interrupt status bits in the I2C_INTR_STAT register.	0x0
9	R/W	M_STOP_DET These bits mask their corresponding interrupt status bits in the I2C_INTR_STAT register.	0x0
8	R/W	M_ACTIVITY These bits mask their corresponding interrupt status bits in the I2C_INTR_STAT register.	0x0
7	R/W	M_RX_DONE These bits mask their corresponding interrupt status bits in the I2C_INTR_STAT register.	0x1
6	R/W	M_TX_ABRT These bits mask their corresponding interrupt status bits in the I2C_INTR_STAT register.	0x1
5	R/W	M_RD_REQ These bits mask their corresponding interrupt status bits in the I2C_INTR_STAT register.	0x1
4	R/W	M_TX_EMPTY	0x1

Bit	Mode	Symbol/Description	Reset
		These bits mask their corresponding interrupt status bits in the I2C_INTR_STAT register.	
3	R/W	M_TX_OVER These bits mask their corresponding interrupt status bits in the I2C_INTR_STAT register.	0x1
2	R/W	M_RX_FULL These bits mask their corresponding interrupt status bits in the I2C_INTR_STAT register.	0x1
1	R/W	M_RX_OVER These bits mask their corresponding interrupt status bits in the I2C_INTR_STAT register.	0x1
0	R/W	M_RX_UNDER These bits mask their corresponding interrupt status bits in the I2C_INTR_STAT register.	0x1

Table 766: I2C2_RAW_INTR_STAT_REG (0x50020734)

Bit	Mode	Symbol/Description	Reset
31:15	-	- Reserved	0x0
14	R	SCL_STUCK_AT_LOW CL_STUCK_AT_LOW Register field Reserved bits.	0x0
13	R	MASTER_ON_HOLD Indicate whether master is holding the bus and TX FIFO is empty. Enabled only when I2C_DYNAMIC_TAR_UPDATE=1 and IC_EMPTYFIFO_HOLD_MASTER_EN=1.	0x0
12	R	RESTART_DET Indicate whether a RESTART condition has occurred on the I2C interface when DW_apb_i2c is operating in Slave mode and the slave is being addressed. Enabled only when IC_SLV_RESTART_DET_EN=1. Note: However, in high-speed mode or during a START BYTE transfer, the RESTART comes before the address field as per the I2C protocol. In this case, the slave is not the addressed slave when the RESTART is issued, therefore DW_apb_i2c does not generate the RESTART_DET interrupt.	0x0
11	R	GEN_CALL Set only when a General Call address is received and it is acknowledged. It stays set until it is cleared either by disabling controller or when the CPU reads bit 0 of the I2C_CLR_GEN_CALL register. I2C Ctrl stores the received data in the Rx buffer.	0x0
10	R	START_DET Indicate whether a START or RESTART condition has occurred on the I2C interface regardless of whether controller is operating in slave or master mode.	0x0
9	R	STOP_DET Indicate whether a STOP condition has occurred on the I2C interface regardless of whether controller is operating in slave or master mode.	0x0
8	R	ACTIVITY This bit captures I2C Ctrl activity and stays set until it is cleared. There are four ways to clear it:	0x0

Bit	Mode	Symbol/Description	Reset
		=> Disabling the I2C Ctrl => Reading the IC_CLR_ACTIVITY register => Reading the IC_CLR_INTR register => System reset Once this bit is set, it stays set unless one of the four methods is used to clear it. Even if the controller module is idle, this bit remains set until cleared, indicating that there was activity on the bus.	
7	R	RX_DONE When the controller is acting as a slave-transmitter, this bit is set to 1 if the master does not acknowledge a transmitted byte. This occurs on the last byte of the transmission, indicating that the transmission is done.	0x0
6	R	TX_ABORT This bit indicates if the controller, as an I2C transmitter, is unable to complete the intended actions on the contents of the transmit FIFO. This situation can occur both as an I2C master or an I2C slave and is referred to as a "transmit abort". When this bit is set to 1, the I2C_TX_ABORT_SOURCE register indicates the reason why the transmit abort takes place. NOTE: The controller flushes/resets/empties the TX FIFO whenever this bit is set. The TX FIFO remains in this flushed state until the register I2C_CLR_TX_ABORT is read. When this read is performed, the TX FIFO is then ready to accept more data bytes from the APB interface.	0x0
5	R	RD_REQ This bit is set to 1 when I2C Ctrl is acting as a slave and another I2C master is attempting to read data from the controller. The controller holds the I2C bus in a wait state (SCL=0) until this interrupt is serviced, which means that the slave has been addressed by a remote master that is asking for data to be transferred. The processor must respond to this interrupt and then write the requested data to the I2C_DATA_CMD register. This bit is set to 0 just after the processor reads the I2C_CLR_RD_REQ register.	0x0
4	R	TX_EMPTY This bit is set to 1 when the transmit buffer is at or below the threshold value set in the I2C_TX_TL register. It is automatically cleared by hardware when the buffer level goes above the threshold. When the IC_ENABLE bit 0 is 0, the TX FIFO is flushed and held in reset. There the TX FIFO looks like it has no data within it, so this bit is set to 1, provided there is activity in the master or slave state machines. When there is no longer activity, then with ic_en=0, this bit is set to 0.	0x0
3	R	TX_OVER Set during transmit if the transmit buffer is filled to 32 and the processor attempts to issue another I2C command by writing to the IC_DATA_CMD register. When the module is disabled, this bit keeps its level until the master or slave state machines go into idle, and when ic_en goes to 0, this interrupt is cleared .	0x0
2	R	RX_FULL Set when the receive buffer reaches or goes above the RX_TL threshold in the I2C_RX_TL register. It is automatically cleared by hardware when buffer level goes below the threshold. If the module is disabled (I2C_ENABLE[0]=0), the RX FIFO is flushed and held in reset; therefore the RX FIFO is not full. So this bit is cleared once the I2C_ENABLE bit 0 is programmed with a 0, regardless of the activity that continues.	0x0
1	R	RX_OVER Set if the receive buffer is completely filled to 32 and an additional byte is received from an external I2C device. The controller acknowledges this, but any data bytes received after the FIFO is full are lost. If the module is disabled	0x0

Bit	Mode	Symbol/Description	Reset
		(I2C_ENABLE[0]=0), this bit keeps its level until the master or slave state machines go into idle, and when ic_en goes to 0, this interrupt is cleared.	
0	R	RX_UNDER Set if the processor attempts to read the receive buffer when it is empty by reading from the IC_DATA_CMD register. If the module is disabled (I2C_ENABLE[0]=0), this bit keeps its level until the master or slave state machines go into idle, and when ic_en goes to 0, this interrupt is cleared.	0x0

Table 767: I2C2_RX_TL_REG (0x50020738)

Bit	Mode	Symbol/Description	Reset
31:5	-	- Reserved	0x0
4:0	R/W	RX_TL Receive FIFO Threshold Level Controls the level of entries (or above) that triggers the RX_FULL interrupt (bit 2 in I2C_RAW_INTR_STAT register). The valid range is 0-31, with the additional restriction that hardware does not allow this value to be set to a value larger than the depth of the buffer. If an attempt is made to do that, the actual value set will be the maximum depth of the buffer. A value of 0 sets the threshold for 1 entry, and a value of 31 sets the threshold for 32 entries.	0x0

Table 768: I2C2_TX_TL_REG (0x5002073C)

Bit	Mode	Symbol/Description	Reset
31:5	-	- Reserved	0x0
4:0	R/W	TX_TL Transmit FIFO Threshold Level Controls the level of entries (or below) that trigger the TX_EMPTY interrupt (bit 4 in I2C_RAW_INTR_STAT register). The valid range is 0-31, with the additional restriction that it may not be set to value larger than the depth of the buffer. If an attempt is made to do that, the actual value set will be the maximum depth of the buffer. A value of 0 sets the threshold for 0 entries, and a value of 31 sets the threshold for 32 entries.	0x0

Table 769: I2C2_CLR_INTR_REG (0x50020740)

Bit	Mode	Symbol/Description	Reset
31:1	-	- Reserved	0x0
0	R	CLR_INTR Read this register to clear the combined interrupt, all individual interrupts, and the I2C_TX_ABRT_SOURCE register. This bit does not clear hardware clearable interrupts but software clearable interrupts. See Bit 9 of the I2C_TX_ABRT_SOURCE register for an exception to clearing I2C_TX_ABRT_SOURCE.	0x0

Table 770: I2C2_CLR_RX_UNDER_REG (0x50020744)

Bit	Mode	Symbol/Description	Reset
31:1	-	-	0x0

Bit	Mode	Symbol/Description	Reset
		Reserved	
0	R	CLR_RX_UNDER Read this register to clear the RX_UNDER interrupt (bit 0) of the I2C_RAW_INTR_STAT register.	0x0

Table 771: I2C2_CLR_RX_OVER_REG (0x50020748)

Bit	Mode	Symbol/Description	Reset
31:1	-	- Reserved	0x0
0	R	CLR_RX_OVER Read this register to clear the RX_OVER interrupt (bit 1) of the I2C_RAW_INTR_STAT register.	0x0

Table 772: I2C2_CLR_TX_OVER_REG (0x5002074C)

Bit	Mode	Symbol/Description	Reset
31:1	-	- Reserved	0x0
0	R	CLR_TX_OVER Read this register to clear the TX_OVER interrupt (bit 3) of the I2C_RAW_INTR_STAT register.	0x0

Table 773: I2C2_CLR_RD_REQ_REG (0x50020750)

Bit	Mode	Symbol/Description	Reset
31:1	-	- Reserved	0x0
0	R	CLR_RD_REQ Read this register to clear the RD_REQ interrupt (bit 5) of the I2C_RAW_INTR_STAT register.	0x0

Table 774: I2C2_CLR_TX_ABRT_REG (0x50020754)

Bit	Mode	Symbol/Description	Reset
31:1	-	- Reserved	0x0
0	R	CLR_TX_ABRT Read this register to clear the TX_ABRT interrupt (bit 6) of the IC_RAW_INTR_STAT register, and the I2C_TX_ABRT_SOURCE register. This also releases the TX FIFO from the flushed/reset state, allowing more writes to the TX FIFO. See Bit 9 of the I2C_TX_ABRT_SOURCE register for an exception to clearing IC_TX_ABRT_SOURCE.	0x0

Table 775: I2C2_CLR_RX_DONE_REG (0x50020758)

Bit	Mode	Symbol/Description	Reset
31:1	-	- Reserved	0x0
0	R	CLR_RX_DONE Read this register to clear the RX_DONE interrupt (bit 7) of the I2C_RAW_INTR_STAT register.	0x0

Table 776: I2C2_CLR_ACTIVITY_REG (0x5002075C)

Bit	Mode	Symbol/Description	Reset
31:1	-	- Reserved	0x0
0	R	CLR_ACTIVITY Reading this register clears the ACTIVITY interrupt if the I2C is not active anymore. If the I2C module is still active on the bus, the ACTIVITY interrupt bit continues to be set. It is automatically cleared by hardware if the module is disabled and if there is no further activity on the bus. The value read from this register to get status of the ACTIVITY interrupt (bit 8) of the IC_RAW_INTR_STAT register.	0x0

Table 777: I2C2_CLR_STOP_DET_REG (0x50020760)

Bit	Mode	Symbol/Description	Reset
31:1	-	- Reserved	0x0
0	R	CLR_STOP_DET Read this register to clear the STOP_DET interrupt (bit 9) of the IC_RAW_INTR_STAT register.	0x0

Table 778: I2C2_CLR_START_DET_REG (0x50020764)

Bit	Mode	Symbol/Description	Reset
31:1	-	- Reserved	0x0
0	R	CLR_START_DET Read this register to clear the START_DET interrupt (bit 10) of the IC_RAW_INTR_STAT register.	0x0

Table 779: I2C2_CLR_GEN_CALL_REG (0x50020768)

Bit	Mode	Symbol/Description	Reset
31:1	-	- Reserved	0x0
0	R	CLR_GEN_CALL Read this register to clear the GEN_CALL interrupt (bit 11) of I2C_RAW_INTR_STAT register.	0x0

Table 780: I2C2_ENABLE_REG (0x5002076C)

Bit	Mode	Symbol/Description	Reset
31:3	-	- Reserved	0x0
2	R/W	I2C_TX_CMD_BLOCK In Master mode: 1 = Block the transmission of data on I2C bus even if TX FIFO has data to transmit. 0 = The transmission of data starts on I2C bus automatically as soon as the first data is available in the TX FIFO.	0x0
1	R/W	I2C_ABORT The software can abort the I2C transfer in master mode by setting this bit. The software can set this bit only when ENABLE is already set; otherwise, the controller ignores any write to ABORT bit. The software cannot clear the ABORT bit once set. In response to an ABORT, the controller issues a STOP and flushes the TX FIFO after completing the current transfer, then sets the TX_ABORT interrupt after the abort operation. The ABORT bit is cleared automatically after the abort operation.	0x0
0	R/W	I2C_EN Control whether the controller is enabled. 0 = Disable the controller (TX and RX FIFOs are held in an erased state) 1 = Enable the controller Software can disable the controller while it is active. However, it is important that care be taken to ensure that the controller is disabled properly. When the controller is disabled, the following occurs: * The TX FIFO and RX FIFO get flushed. * Status bits in the IC_INTR_STAT register are still active until the controller goes into IDLE state. If the module is transmitting, it stops as well as deletes the contents of the transmit buffer after the current transfer is complete. If the module is receiving, the controller stops the current transfer at the end of the current byte and does not acknowledge the transfer. There is a two ic_clk delay when enabling or disabling the controller.	0x0

Table 781: I2C2_STATUS_REG (0x50020770)

Bit	Mode	Symbol/Description	Reset
31:11	-	- Reserved	0x0
10	R	LV_HOLD_RX_FIFO_FULL This bit indicates the BUS Hold in Slave mode due to RX FIFO is Full and an additional byte has been received. 1 = Slave holds the bus due to Rx FIFO is full. 0 = Slave is not holding the bus or Bus hold is not due to Rx FIFO is full.	0x0
9	R	SLV_HOLD_TX_FIFO_EMPTY This bit indicates the BUS Hold in Slave mode for the Read request when the TX FIFO is empty. The Bus is in hold until the TX FIFO has data to Transmit for the read request. 1 = Slave holds the bus due to TX FIFO is empty. 0 = Slave is not holding the bus or Bus hold is not due to TX FIFO is empty.	0x0

Bit	Mode	Symbol/Description	Reset
8	R	<p>MST_HOLD_RX_FIFO_FULL</p> <p>This bit indicates the BUS Hold in Master mode due to RX FIFO is Full and additional byte is received.</p> <p>1 = Master holds the bus due to RX FIFO is full.</p> <p>0 = Master is not holding the bus or Bus hold is not due to RX FIFO is full.</p>	0x0
7	R	<p>MST_HOLD_TX_FIFO_EMPTY</p> <p>The DW_apb_i2c master stalls the write transfer when TX FIFO is empty, and the the last byte does not have the Stop bit set. This bit indicates the BUS hold when the master holds the bus because of the TX FIFO being empty, and the the previous transferred command does not have the Stop bit set.</p> <p>1 = Master holds the bus due to TX FIFO is empty.</p> <p>0 = Master is not holding the bus or Bus hold is not due to TX FIFO is empty.</p>	0x0
6	R	<p>SLV_ACTIVITY</p> <p>Slave FSM Activity Status. When the Slave Finite State Machine (FSM) is not in the IDLE state, this bit is set.</p> <p>0 = Slave FSM is in IDLE state so the Slave part of the controller is not Active.</p> <p>1 = Slave FSM is not in IDLE state so the Slave part of the controller is Active.</p>	0x0
5	R	<p>MST_ACTIVITY</p> <p>Master FSM Activity Status. When the Master Finite State Machine (FSM) is not in the IDLE state, this bit is set.</p> <p>0 = Master FSM is in IDLE state so the Master part of the controller is not Active.</p> <p>1 = Master FSM is not in IDLE state so the Master part of the controller is Active.</p>	0x0
4	R	<p>RFF</p> <p>Receive FIFO Completely Full. When the receive FIFO is completely full, this bit is set. When the receive FIFO contains one or more empty location, this bit is cleared.</p> <p>0 = Receive FIFO is not full.</p> <p>1 = Receive FIFO is full.</p>	0x0
3	R	<p>RFNE</p> <p>Receive FIFO Not Empty. This bit is set when the receive FIFO contains one or more entries; it is cleared when the receive FIFO is empty.</p> <p>0 = Receive FIFO is empty.</p> <p>1 = Receive FIFO is not empty.</p>	0x0
2	R	<p>TFE</p> <p>Transmit FIFO Completely Empty. When the transmit FIFO is completely empty, this bit is set. When it contains one or more valid entries, this bit is cleared. This bit field does not request an interrupt.</p> <p>0 = Transmit FIFO is not empty.</p> <p>1 = Transmit FIFO is empty.</p>	0x1
1	R	<p>TFNF</p> <p>Transmit FIFO Not Full. Set when the transmit FIFO contains one or more empty locations, and is cleared when the FIFO is full.</p> <p>0 = Transmit FIFO is full.</p> <p>1 = Transmit FIFO is not full.</p>	0x1
0	R	<p>I2C_ACTIVITY</p> <p>I2C Activity Status.</p>	0x0

Table 782: I2C2_TXFLR_REG (0x50020774)

Bit	Mode	Symbol/Description	Reset
31:6	-	- Reserved	0x0
5:0	R	TXFLR Transmit FIFO Level. Contain the number of valid data entries in the transmit FIFO. Size is constrained by the TXFLR value.	0x0

Table 783: I2C2_RXFLR_REG (0x50020778)

Bit	Mode	Symbol/Description	Reset
31:6	-	- Reserved	0x0
5:0	R	RXFLR Receive FIFO Level. Contain the number of valid data entries in the receive FIFO. Size is constrained by the RXFLR value.	0x0

Table 784: I2C2_SDA_HOLD_REG (0x5002077C)

Bit	Mode	Symbol/Description	Reset
23:16	R/W	I2C_SDA_RX_HOLD Set the required SDA hold time in units of ic_clk period when receiving.	0x0
15:0	R/W	I2C_SDA_TX_HOLD Set the required SDA hold time in units of ic_clk period when transmitting.	0x1

Table 785: I2C2_TX_ABRT_SOURCE_REG (0x50020780)

Bit	Mode	Symbol/Description	Reset
16	R	ABRT_USER_ABRT Master-Transmitter: This is a master-mode-only bit. Master has detected the transfer abort (IC_ENABLE[1]).	0x0
15	R	ABRT_SLVRD_INTX Slave-Transmitter: When the processor side responds to a slave mode request for data to be transmitted to a remote master and a user writes a 1 in CMD (bit 8) of I2C_DATA_CMD register. 1 = Slave trying to transmit to remote master in read mode. 0 = Slave trying to transmit to remote master in read mode- scenario not present.	0x0
14	R	ABRT_SLV_ARBLOST Slave-Transmitter: Slave lost the bus while transmitting data to a remote master. I2C_TX_ABRT_SOURCE[12] is set at the same time. Note: Even though the slave never "owns" the bus, something could go wrong on the bus. This is a fail safe check. For instance, during a data transmission at the low-to-high transition of SCL, if what is on the data bus is not what is supposed to be transmitted, then the controller no longer own the bus. 1 = Slave lost arbitration to remote master. 0 = Slave lost arbitration to remote master- scenario not present.	0x0
13	R	ABRT_SLVFLUSH_TXFIFO	0x0

Bit	Mode	Symbol/Description	Reset
		Slave-Transmitter: Slave has received a read command and some data exists in the TX FIFO so the slave issues a TX_ABRT interrupt to flush old data in TX FIFO. 1 = Slave flushes existing data in TX-FIFO upon getting read command. 0 = Slave flushes existing data in TX-FIFO upon getting read command- scenario not present.	
12	R	ARB_LOST Master-Transmitter or Slave-Transmitter: Master has lost arbitration, or if I2C_TX_ABRT_SOURCE[14] is also set, then the slave transmitter has lost arbitration. Note: I2C can be both master and slave at the same time. 1 = Master or Slave-Transmitter lost arbitration. 0 = Master or Slave-Transmitter lost arbitration- scenario not present.	0x0
11	R	ABRT_MASTER_DIS Master-Transmitter or Master-Receiver: User tries to initiate a Master operation with the Master mode disabled. 1 = User initiating master operation when MASTER disable. 0 = User initiating master operation when MASTER disabled- scenario not present.	0x0
10	R	ABRT_10B_RD_NORSTRT Master-Receiver: The restart is disabled (IC_RESTART_EN bit (I2C_CON[5]) = 0) and the master sends a read command in 10-bit addressing mode. 1 = Master trying to read in 10-bit addressing mode when RESTART disabled. 0 = Master not trying to read in 10-bit addressing mode when RESTART disabled.	0x0
9	R	ABRT_SBYTE_NORSTRT Master: To clear Bit 9, the source of the ABRT_SBYTE_NORSTRT must be fixed first; restart must be enabled (I2C_CON[5]=1), the SPECIAL bit must be cleared (I2C_TAR[11]), or the GC_OR_START bit must be cleared (I2C_TAR[10]). Once the source of the ABRT_SBYTE_NORSTRT is fixed, then this bit can be cleared in the same manner as other bits in this register. If the source of the ABRT_SBYTE_NORSTRT is not fixed before attempting to clear this bit, bit 9 clears for one cycle and then gets re-asserted. 1: The restart is disabled (IC_RESTART_EN bit (I2C_CON[5]) = 0) and the user is trying to send a START Byte. 1 = User trying to send START byte when RESTART disabled. 0 = User trying to send START byte when RESTART disabled- scenario not present.	0x0
8	R	ABRT_HS_NORSTRT Master-Transmitter or Master-Receiver: The restart is disabled (IC_RESTART_EN bit (I2C_CON[5]) = 0) and the user is trying to use the master to transfer data in High Speed mode. 1 = User trying to switch Master to HS mode when RESTART disabled. 0 = User trying to switch Master to HS mode when RESTART disabled- scenario not present.	0x0
7	R	ABRT_SBYTE_ACKDET Master: Master has sent a START Byte and the START Byte was acknowledged (wrong behavior). 1 = ACK detected for START byte. 0 = ACK detected for START byte- scenario not present.	0x0
6	R	ABRT_HS_ACKDET Master: Master is in High Speed mode and the High Speed Master code was acknowledged (wrong behavior). 1 = HS Master code ACKed in HS Mode.	0x0

Bit	Mode	Symbol/Description	Reset
		0 = HS Master code ACKed in HS Mode- scenario not present.	
5	R	ABRT_GCALL_READ Master-Transmitter: The controller in master mode sent a General Call but the user programmed the byte following the General Call to be a read from the bus (IC_DATA_CMD[9] is set to 1). 1 = GCALL is followed by read from bus. 0 = GCALL is followed by read from bus-scenario not present.	0x0
4	R	ABRT_GCALL_NOACK Master-Transmitter: The controller in master mode sent a General Call and no slave on the bus acknowledged the General Call. 1 = GCALL not ACKed by any slave. 0 = GCALL not ACKed by any slave-scenario not present.	0x0
3	R	ABRT_TXDATA_NOACK Master-Transmitter: This is a master-mode only bit. Master has received an acknowledgement for the address, but when it sent data byte(s) following the address, it did not receive an acknowledge from the remote slave(s). 1 = Transmitted data not ACKed by addressed slave. 0 = Transmitted data non-ACKed by addressed slave-scenario not present.	0x0
2	R	ABRT_10ADDR2_NOACK Master-Transmitter or Master-Receiver: Master is in 10-bit address mode and the second address byte of the 10-bit address was not acknowledged by any slave. 1 = Byte 2 of 10-bit address not ACKed by any slave. 0 = This abort is not generated.	0x0
1	R	ABRT_10ADDR1_NOACK Master-Transmitter or Master-Receiver: Master is in 10-bit address mode and the first 10-bit address byte was not acknowledged by any slave. 1 = Byte 1 of 10-bit address not ACKed by any slave. 0 = This abort is not generated.	0x0
0	R	ABRT_7B_ADDR_NOACK Master-Transmitter or Master-Receiver: Master is in 7-bit addressing mode and the address sent was not acknowledged by any slave. 1 = This abort is generated because of NOACK for 7-bit address. 0 = This abort is not generated.	0x0

Table 786: I2C2_DMA_CR_REG (0x50020788)

Bit	Mode	Symbol/Description	Reset
1	R/W	TDMAE Transmit DMA Enable. This bit enables/disables the transmit FIFO DMA channel. 0 = Transmit DMA disabled. 1 = Transmit DMA enabled.	0x0
0	R/W	RDMAE Receive DMA Enable. This bit enables/disables the receive FIFO DMA channel. 0 = Receive DMA disabled. 1 = Receive DMA enabled.	0x0

Table 787: I2C2_DMA_TDLR_REG (0x5002078C)

Bit	Mode	Symbol/Description	Reset
4:0	R/W	DMATDL Transmit Data Level. This bit field controls the level at which a DMA request is made by the transmit logic. It is equal to the watermark level; that is, the dma_tx_req signal is generated when the number of valid data entries in the transmit FIFO is equal to or below this field value, and TDMAE = 1.	0x0

Table 788: I2C2_DMA_RDLR_REG (0x50020790)

Bit	Mode	Symbol/Description	Reset
4:0	R/W	DMARDL Receive Data Level. This bit field controls the level at which a DMA request is made by the receive logic. The watermark level = DMARDL+1; that is, dma_rx_req is generated when the number of valid data entries in the receive FIFO is equal to or more than this field value + 1, and RDMAE = 1. For instance, when DMARDL is 0, then dma_rx_req is asserted when 1 or more data entries are present in the receive FIFO.	0x0

Table 789: I2C2_SDA_SETUP_REG (0x50020794)

Bit	Mode	Symbol/Description	Reset
15:8	-	- Reserved	0x0
7:0	R/W	SDA_SETUP SDA Setup. This register controls the amount of time delay (number of I2C clock periods) between the rising edge of SCL and SDA changing by holding SCL low when I2C block services a read request while operating as a slave-transmitter. The relevant I2C requirement is tSU:DAT (note 4) as detailed in the I2C Bus Specification. This register must be programmed with a value equal to or greater than 2. It is recommended that if the required delay is 1000 ns, then for an I2C frequency of 10 MHz, IC_SDA_SETUP should be programmed to a value of 11. Write to this register succeed only when IC_ENABLE[0] = 0.	0x64

Table 790: I2C2_ACK_GENERAL_CALL_REG (0x50020798)

Bit	Mode	Symbol/Description	Reset
15:1	-	- Reserved	0x0
0	R/W	ACK_GEN_CALL ACK General Call. When set to 1, I2C Ctrl responds with a ACK (by asserting ic_data_oe) when it receives a General Call. When set to 0, the controller does not generate General Call interrupts. 1 = Generate ACK for a General Call. 0 = Generate NACK for General Call.	0x0

Table 791: I2C2_ENABLE_STATUS_REG (0x5002079C)

Bit	Mode	Symbol/Description	Reset
15:3	-	-	0x0

Bit	Mode	Symbol/Description	Reset
		Reserved	
2	R	<p>SLV_RX_DATA_LOST</p> <p>Slave Received Data Lost. This bit indicates if a Slave-Receiver operation is aborted with at least one data byte received from an I2C transfer due to the setting of IC_ENABLE from 1 to 0. When read as 1, the controller is deemed to have actively engaged in an aborted I2C transfer (with matching address) and the data phase of the I2C transfer is entered, even though a data byte is responded with a NACK. NOTE: If the remote I2C master terminates the transfer with a STOP condition before the controller has a chance to NACK a transfer, and IC_ENABLE is set to 0, then this bit is also set to 1. When read as 0, the controller is deemed to have disabled without being actively involved in the data phase of a Slave-Receiver transfer.</p> <p>NOTE: The CPU can safely read this bit when IC_EN (bit 0) is read as 0.</p> <p>1 = Slave RX Data is lost. 0 = Slave RX Data is not lost.</p>	0x0
1	R	<p>SLV_DISABLED_WHILE_BUSY</p> <p>Slave Disabled While Busy (Transmit, Receive). This bit indicates if a potential or active Slave operation has aborted due to the setting of the IC_ENABLE register from 1 to 0. This bit is set when the CPU writes a 0 to the IC_ENABLE register while:</p> <p>(a) I2C Ctrl is receiving the address byte of the Slave-Transmitter operation from a remote master; OR,</p> <p>(b) address and data bytes of the Slave-Receiver operation from a remote master. When read as 1, the controller is deemed to have forced a NACK during any part of an I2C transfer, irrespective of whether the I2C address matches the slave address set in I2C Ctrl (IC_SAR register) OR if the transfer is completed before IC_ENABLE is set to 0, but has not taken effect.</p> <p>NOTE: If the remote I2C master terminates the transfer with a STOP condition before the the controller has a chance to NACK a transfer, and IC_ENABLE is set to 0, then this bit is also set to 1.</p> <p>When read as 0, the controller is deemed to be disabled when there is master activity, or when the I2C bus is idle.</p> <p>NOTE: The CPU can safely read this bit when IC_EN (bit 0) is read as 0.</p> <p>1 = Slave is disabled when it is active. 0 = Slave is disabled when it is idle.</p>	0x0
0	R	<p>IC_EN</p> <p>ic_en Status. This bit always reflects the value driven on the output port ic_en. When read as 1, the controller is deemed to be in an enabled state. When read as 0, the controller is deemed completely inactive.</p> <p>NOTE: The CPU can safely read this bit anytime. When this bit is read as 0, the CPU can safely read SLV_RX_DATA_LOST (bit 2) and SLV_DISABLED_WHILE_BUSY (bit 1).</p> <p>1 = I2C enabled. 0 = I2C disabled.</p>	0x0

Table 792: I2C2_IC_FS_SPKLEN_REG (0x500207A0)

Bit	Mode	Symbol/Description	Reset
15:8	-	- Reserved	0x0
7:0	R/W	I2C_FS_SPKLEN	0x1

Bit	Mode	Symbol/Description	Reset
		This register must be set before any I2C bus transaction can take place to ensure stable operation. This register sets the duration, measured in ic_clk cycles, of the longest spike in the SCL or SDA lines that are filtered out by the spike suppression logic. This register can be written only when the I2C interface is disabled which corresponds to the IC_ENABLE register being set to 0. Write at other times have no effect. The minimum valid value is 1; hardware prevents values less than this being written, and if attempted results in 1 being set.	

Table 793: I2C2_IC_HS_SPKLEN_REG (0x500207A4)

Bit	Mode	Symbol/Description	Reset
7:0	R/W	I2C_HS_SPKLEN This register must be set before any I2C bus transaction can take place to ensure stable operation. This register sets the duration, measured in ic_clk cycles, of the longest spike in the SCL or SDA lines that are filtered out by the spike suppression logic. This register can be written only when the I2C interface is disabled which corresponds to the IC_ENABLE[0] register being set to 0. Write at other times have no effect. The minimum valid value is 1; hardware prevents values less than this being written, and if attempted results in 1 being set.	0x1

42.25 Power Domain Controller Registers

Table 794: Register map PDC

Address	Register	Description
0x50000200	PDC_CTRL0_REG	PDC control register
0x50000204	PDC_CTRL1_REG	PDC control register
0x50000208	PDC_CTRL2_REG	PDC control register
0x5000020C	PDC_CTRL3_REG	PDC control register
0x50000210	PDC_CTRL4_REG	PDC control register
0x50000214	PDC_CTRL5_REG	PDC control register
0x50000218	PDC_CTRL6_REG	PDC control register
0x5000021C	PDC_CTRL7_REG	PDC control register
0x50000220	PDC_CTRL8_REG	PDC control register
0x50000224	PDC_CTRL9_REG	PDC control register
0x50000228	PDC_CTRL10_REG	PDC control register
0x5000022C	PDC_CTRL11_REG	PDC control register
0x50000230	PDC_CTRL12_REG	PDC control register
0x50000234	PDC_CTRL13_REG	PDC control register
0x50000238	PDC_CTRL14_REG	PDC control register
0x5000023C	PDC_CTRL15_REG	PDC control register
0x50000280	PDC_ACKNOWLEDGE_REG	Clear a pending PDC bit
0x50000284	PDC_PENDING_REG	Shows any pending wakeup event
0x50000288	PDC_PENDING_SNC_REG	Shows any pending IRQ to SNC

Address	Register	Description
0x5000028C	PDC_PENDING_CM33_REG	Shows any pending IRQ to CM33
0x50000290	PDC_PENDING_CMAC_REG	Shows any pending IRQ to CMAC
0x50000294	PDC_SET_PENDING_REG	Set a pending PDC bit

Table 795: [PDC_CTRL0_REG \(0x50000200\)](#)

Bit	Mode	Symbol	Description	Reset
12:11	R/W	PDC_MASTER	Chooses which master is triggered when waking up 0x0: entry is disabled. 0x1: PD_SYS is woken up and CM33 is triggered 0x2: PD_RAD is woken up and CMAC is triggered 0x3: PD_COM is woken up and SNC is triggered	0x0
10	R/W	EN_COM	If set, enables PD_COM for GPIO access. This bit is implied when PDC_MASTER=SNC	0x0
9	R/W	EN_PER	If set, enables PD_PER	0x0
8	R/W	EN_TMR	If set, enables PD_TMR	0x0
7	R/W	EN_XTAL	If set, the XTAL32M will be started	0x0
6:2	R/W	TRIG_ID	Selects which individual bit from the selected bank is used for wakeup. For the peripheral banks, selected with TRIG_SELECT = 0x2 or 0x3, only the lower 4 bits are considered.	0x0
1:0	R/W	TRIG_SELECT	Selects which bank is used as wakeup trigger When TRIG_SELECT is 0x0, selects GPIO port0 through the WAKEUP block. When TRIG_SELECT is 0x1, selects GPIO port1 through the WAKEUP block. When TRIG_SELECT is 0x2 or 0x3, selects the peripheral IRQ. peripheral IRQ table: 0x0: Timer 0x1: Timer2 0x2: Timer3 0x3: Timer4 0x4: RTC Alarm/Rollover 0x5: RTC Timer 0x6: CMAC Timer OR wake up from CMAC debugger 0x7: Motor Controller 0x8: XTAL32MRDY_IRQ 0x9: RFDIAG_IRQ 0xA: CMAC2SYS_IRQ OR VBUS Present IRQ OR JTAG present OR Debounced IO 0xB: Sensor Node Controller 0xC to 0xE: reserved 0xF: Software trigger only	0x0

Bit	Mode	Symbol	Description	Reset

Table 796: PDC_CTRL1_REG (0x50000204)

Bit	Mode	Symbol	Description	Reset
12:11	R/W	PDC_MASTER	Chooses which master is triggered when waking up 0x0: entry is disabled. 0x1: PD_SYS is woken up and CM33 is triggered 0x2: PD_RAD is woken up and CMAC is triggered 0x3: PD_COM is woken up and SNC is triggered	0x0
10	R/W	EN_COM	If set, enables PD_COM for GPIO access. This bit is implied when PDC_MASTER=SNC	0x0
9	R/W	EN_PER	If set, enables PD_PER	0x0
8	R/W	EN_TMR	If set, enables PD_TMR	0x0
7	R/W	EN_XTAL	If set, the XTAL32M will be started	0x0
6:2	R/W	TRIG_ID	For description, see PDC_CTRL0_REG.TRIG_ID	0x0
1:0	R/W	TRIG_SELECT	For description, see PDC_CTRL0_REG.TRIG_SELECT	0x0

Table 797: PDC_CTRL2_REG (0x50000208)

Bit	Mode	Symbol	Description	Reset
12:11	R/W	PDC_MASTER	Chooses which master is triggered when waking up 0x0: entry is disabled. 0x1: PD_SYS is woken up and CM33 is triggered 0x2: PD_RAD is woken up and CMAC is triggered 0x3: PD_COM is woken up and SNC is triggered	0x0
10	R/W	EN_COM	If set, enables PD_COM for GPIO access. This bit is implied when PDC_MASTER=SNC	0x0
9	R/W	EN_PER	If set, enables PD_PER	0x0
8	R/W	EN_TMR	If set, enables PD_TMR	0x0
7	R/W	EN_XTAL	If set, the XTAL32M will be started	0x0
6:2	R/W	TRIG_ID	For description, see PDC_CTRL0_REG.TRIG_ID	0x0
1:0	R/W	TRIG_SELECT	For description, see PDC_CTRL0_REG.TRIG_SELECT	0x0

Table 798: PDC_CTRL3_REG (0x5000020C)

Bit	Mode	Symbol	Description	Reset
12:11	R/W	PDC_MASTER	Chooses which master is triggered when waking up 0x0: entry is disabled. 0x1: PD_SYS is woken up and CM33 is triggered 0x2: PD_RAD is woken up and CMAC is triggered 0x3: PD_COM is woken up and SNC is triggered	0x0
10	R/W	EN_COM	If set, enables PD_COM for GPIO access. This bit is implied when PDC_MASTER=SNC	0x0
9	R/W	EN_PER	If set, enables PD_PER	0x0

Bit	Mode	Symbol	Description	Reset
8	R/W	EN_TMR	If set, enables PD_TMR	0x0
7	R/W	EN_XTAL	If set, the XTAL32M will be started	0x0
6:2	R/W	TRIG_ID	For description, see PDC_CTRL0_REG.TRIG_ID	0x0
1:0	R/W	TRIG_SELECT	For description, see PDC_CTRL0_REG.TRIG_SELECT	0x0

Table 799: PDC_CTRL4_REG (0x50000210)

Bit	Mode	Symbol	Description	Reset
12:11	R/W	PDC_MASTER	Chooses which master is triggered when waking up 0x0: entry is disabled. 0x1: PD_SYS is woken up and CM33 is triggered 0x2: PD_RAD is woken up and CMAC is triggered 0x3: PD_COM is woken up and SNC is triggered	0x0
10	R/W	EN_COM	If set, enables PD_COM for GPIO access. This bit is implied when PDC_MASTER=SNC	0x0
9	R/W	EN_PER	If set, enables PD_PER	0x0
8	R/W	EN_TMR	If set, enables PD_TMR	0x0
7	R/W	EN_XTAL	If set, the XTAL32M will be started	0x0
6:2	R/W	TRIG_ID	For description, see PDC_CTRL0_REG.TRIG_ID	0x0
1:0	R/W	TRIG_SELECT	For description, see PDC_CTRL0_REG.TRIG_SELECT	0x0

Table 800: PDC_CTRL5_REG (0x50000214)

Bit	Mode	Symbol	Description	Reset
12:11	R/W	PDC_MASTER	Chooses which master is triggered when waking up 0x0: entry is disabled. 0x1: PD_SYS is woken up and CM33 is triggered 0x2: PD_RAD is woken up and CMAC is triggered 0x3: PD_COM is woken up and SNC is triggered	0x0
10	R/W	EN_COM	If set, enables PD_COM for GPIO access. This bit is implied when PDC_MASTER=SNC	0x0
9	R/W	EN_PER	If set, enables PD_PER	0x0
8	R/W	EN_TMR	If set, enables PD_TMR	0x0
7	R/W	EN_XTAL	If set, the XTAL32M will be started	0x0
6:2	R/W	TRIG_ID	For description, see PDC_CTRL0_REG.TRIG_ID	0x0
1:0	R/W	TRIG_SELECT	For description, see PDC_CTRL0_REG.TRIG_SELECT	0x0

Table 801: PDC_CTRL6_REG (0x50000218)

Bit	Mode	Symbol	Description	Reset
12:11	R/W	PDC_MASTER	Chooses which master is triggered when waking up 0x0: entry is disabled. 0x1: PD_SYS is woken up and CM33 is triggered 0x2: PD_RAD is woken up and CMAC is triggered 0x3: PD_COM is woken up and SNC is triggered	0x0

Bit	Mode	Symbol	Description	Reset
10	R/W	EN_COM	If set, enables PD_COM for GPIO access. This bit is implied when PDC_MASTER=SNC	0x0
9	R/W	EN_PER	If set, enables PD_PER	0x0
8	R/W	EN_TMR	If set, enables PD_TMR	0x0
7	R/W	EN_XTAL	If set, the XTAL32M will be started	0x0
6:2	R/W	TRIG_ID	For description, see PDC_CTRL0_REG.TRIG_ID	0x0
1:0	R/W	TRIG_SELECT	For description, see PDC_CTRL0_REG.TRIG_SELECT	0x0

Table 802: PDC_CTRL7_REG (0x5000021C)

Bit	Mode	Symbol	Description	Reset
12:11	R/W	PDC_MASTER	Chooses which master is triggered when waking up 0x0: entry is disabled. 0x1: PD_SYS is woken up and CM33 is triggered 0x2: PD_RAD is woken up and CMAC is triggered 0x3: PD_COM is woken up and SNC is triggered	0x0
10	R/W	EN_COM	If set, enables PD_COM for GPIO access. This bit is implied when PDC_MASTER=SNC	0x0
9	R/W	EN_PER	If set, enables PD_PER	0x0
8	R/W	EN_TMR	If set, enables PD_TMR	0x0
7	R/W	EN_XTAL	If set, the XTAL32M will be started	0x0
6:2	R/W	TRIG_ID	For description, see PDC_CTRL0_REG.TRIG_ID	0x0
1:0	R/W	TRIG_SELECT	For description, see PDC_CTRL0_REG.TRIG_SELECT	0x0

Table 803: PDC_CTRL8_REG (0x50000220)

Bit	Mode	Symbol	Description	Reset
12:11	R/W	PDC_MASTER	Chooses which master is triggered when waking up 0x0: entry is disabled. 0x1: PD_SYS is woken up and CM33 is triggered 0x2: PD_RAD is woken up and CMAC is triggered 0x3: PD_COM is woken up and SNC is triggered	0x0
10	R/W	EN_COM	If set, enables PD_COM for GPIO access. This bit is implied when PDC_MASTER=SNC	0x0
9	R/W	EN_PER	If set, enables PD_PER	0x0
8	R/W	EN_TMR	If set, enables PD_TMR	0x0
7	R/W	EN_XTAL	If set, the XTAL32M will be started	0x0
6:2	R/W	TRIG_ID	For description, see PDC_CTRL0_REG.TRIG_ID	0x0
1:0	R/W	TRIG_SELECT	For description, see PDC_CTRL0_REG.TRIG_SELECT	0x0

Table 804: PDC_CTRL9_REG (0x50000224)

Bit	Mode	Symbol	Description	Reset
12:11	R/W	PDC_MASTER	Chooses which master is triggered when waking up 0x0: entry is disabled.	0x0

Bit	Mode	Symbol	Description	Reset
			0x1: PD_SYS is woken up and CM33 is triggered 0x2: PD_RAD is woken up and CMAC is triggered 0x3: PD_COM is woken up and SNC is triggered	
10	R/W	EN_COM	If set, enables PD_COM for GPIO access. This bit is implied when PDC_MASTER=SNC	0x0
9	R/W	EN_PER	If set, enables PD_PER	0x0
8	R/W	EN_TMR	If set, enables PD_TMR	0x0
7	R/W	EN_XTAL	If set, the XTAL32M will be started	0x0
6:2	R/W	TRIG_ID	For description, see PDC_CTRL0_REG.TRIG_ID	0x0
1:0	R/W	TRIG_SELECT	For description, see PDC_CTRL0_REG.TRIG_SELECT	0x0

Table 805: PDC_CTRL10_REG (0x50000228)

Bit	Mode	Symbol	Description	Reset
12:11	R/W	PDC_MASTER	Chooses which master is triggered when waking up 0x0: entry is disabled. 0x1: PD_SYS is woken up and CM33 is triggered 0x2: PD_RAD is woken up and CMAC is triggered 0x3: PD_COM is woken up and SNC is triggered	0x0
10	R/W	EN_COM	If set, enables PD_COM for GPIO access. This bit is implied when PDC_MASTER=SNC	0x0
9	R/W	EN_PER	If set, enables PD_PER	0x0
8	R/W	EN_TMR	If set, enables PD_TMR	0x0
7	R/W	EN_XTAL	If set, the XTAL32M will be started	0x0
6:2	R/W	TRIG_ID	For description, see PDC_CTRL0_REG.TRIG_ID	0x0
1:0	R/W	TRIG_SELECT	For description, see PDC_CTRL0_REG.TRIG_SELECT	0x0

Table 806: PDC_CTRL11_REG (0x5000022C)

Bit	Mode	Symbol	Description	Reset
12:11	R/W	PDC_MASTER	Chooses which master is triggered when waking up 0x0: entry is disabled. 0x1: PD_SYS is woken up and CM33 is triggered 0x2: PD_RAD is woken up and CMAC is triggered 0x3: PD_COM is woken up and SNC is triggered	0x0
10	R/W	EN_COM	If set, enables PD_COM for GPIO access. This bit is implied when PDC_MASTER=SNC	0x0
9	R/W	EN_PER	If set, enables PD_PER	0x0
8	R/W	EN_TMR	If set, enables PD_TMR	0x0
7	R/W	EN_XTAL	If set, the XTAL32M will be started	0x0
6:2	R/W	TRIG_ID	For description, see PDC_CTRL0_REG.TRIG_ID	0x0
1:0	R/W	TRIG_SELECT	For description, see PDC_CTRL0_REG.TRIG_SELECT	0x0

Table 807: PDC_CTRL12_REG (0x50000230)

Bit	Mode	Symbol	Description	Reset
12:11	R/W	PDC_MASTER	Chooses which master is triggered when waking up 0x0: entry is disabled. 0x1: PD_SYS is woken up and CM33 is triggered 0x2: PD_RAD is woken up and CMAC is triggered 0x3: PD_COM is woken up and SNC is triggered	0x0
10	R/W	EN_COM	If set, enables PD_COM for GPIO access. This bit is implied when PDC_MASTER=SNC	0x0
9	R/W	EN_PER	If set, enables PD_PER	0x0
8	R/W	EN_TMR	If set, enables PD_TMR	0x0
7	R/W	EN_XTAL	If set, the XTAL32M will be started	0x0
6:2	R/W	TRIG_ID	For description, see PDC_CTRL0_REG.TRIG_ID	0x0
1:0	R/W	TRIG_SELECT	For description, see PDC_CTRL0_REG.TRIG_SELECT	0x0

Table 808: PDC_CTRL13_REG (0x50000234)

Bit	Mode	Symbol	Description	Reset
12:11	R/W	PDC_MASTER	Chooses which master is triggered when waking up 0x0: entry is disabled. 0x1: PD_SYS is woken up and CM33 is triggered 0x2: PD_RAD is woken up and CMAC is triggered 0x3: PD_COM is woken up and SNC is triggered	0x0
10	R/W	EN_COM	If set, enables PD_COM for GPIO access. This bit is implied when PDC_MASTER=SNC	0x0
9	R/W	EN_PER	If set, enables PD_PER	0x0
8	R/W	EN_TMR	If set, enables PD_TMR	0x0
7	R/W	EN_XTAL	If set, the XTAL32M will be started	0x0
6:2	R/W	TRIG_ID	For description, see PDC_CTRL0_REG.TRIG_ID	0x0
1:0	R/W	TRIG_SELECT	For description, see PDC_CTRL0_REG.TRIG_SELECT	0x0

Table 809: PDC_CTRL14_REG (0x50000238)

Bit	Mode	Symbol	Description	Reset
12:11	R/W	PDC_MASTER	Chooses which master is triggered when waking up 0x0: entry is disabled. 0x1: PD_SYS is woken up and CM33 is triggered 0x2: PD_RAD is woken up and CMAC is triggered 0x3: PD_COM is woken up and SNC is triggered	0x0
10	R/W	EN_COM	If set, enables PD_COM for GPIO access. This bit is implied when PDC_MASTER=SNC	0x0
9	R/W	EN_PER	If set, enables PD_PER	0x0
8	R/W	EN_TMR	If set, enables PD_TMR	0x0
7	R/W	EN_XTAL	If set, the XTAL32M will be started	0x0
6:2	R/W	TRIG_ID	For description, see PDC_CTRL0_REG.TRIG_ID	0x0
1:0	R/W	TRIG_SELECT	For description, see PDC_CTRL0_REG.TRIG_SELECT	0x0

Table 810: **PDC_CTRL15_REG (0x5000023C)**

Bit	Mode	Symbol	Description	Reset
12:11	R/W	PDC_MASTER	Chooses which master is triggered when waking up 0x0: entry is disabled. 0x1: PD_SYS is woken up and CM33 is triggered 0x2: PD_RAD is woken up and CMAC is triggered 0x3: PD_COM is woken up and SNC is triggered	0x0
10	R/W	EN_COM	If set, enables PD_COM for GPIO access. This bit is implied when PDC_MASTER=SNC	0x0
9	R/W	EN_PER	If set, enables PD_PER	0x0
8	R/W	EN_TMR	If set, enables PD_TMR	0x0
7	R/W	EN_XTAL	If set, the XTAL32M will be started	0x0
6:2	R/W	TRIG_ID	For description, see PDC_CTRL0_REG.TRIG_ID	0x0
1:0	R/W	TRIG_SELECT	For description, see PDC_CTRL0_REG.TRIG_SELECT	0x0

Table 811: **PDC_ACKNOWLEDGE_REG (0x50000280)**

Bit	Mode	Symbol	Description	Reset
4:0	W	PDC_ACKNOWLEDGE	Writing to this field acknowledges the PDC IRQ request. The data controls which request is acknowledged	0x0

Table 812: **PDC_PENDING_REG (0x50000284)**

Bit	Mode	Symbol	Description	Reset
15:0	R	PDC_PENDING	Indicates which IRQ ids are pending	0x0

Table 813: **PDC_PENDING_SNC_REG (0x50000288)**

Bit	Mode	Symbol	Description	Reset
15:0	R	PDC_PENDING	Indicates which IRQ ids are pending towards the SensorNodeController	0x0

Table 814: **PDC_PENDING_CM33_REG (0x5000028C)**

Bit	Mode	Symbol	Description	Reset
15:0	R	PDC_PENDING	Indicates which IRQ ids are pending towards the CM33	0x0

Table 815: **PDC_PENDING_CM33_REG (0x50000290)**

Bit	Mode	Symbol	Description	Reset
15:0	R	PDC_PENDING	Indicates which IRQ ids are pending towards the CMAC	0x0

Table 816: PDC_SET_PENDING_REG (0x50000294)

Bit	Mode	Symbol	Description	Reset
4:0	W	PDC_SET_PENDING	Writing to this field sets the PDC wakeup request and IRQ. The data controls which request is acknowledged	0x0

42.26 DCDC Converter Registers

Table 817: Register map DCDC

Address	Register	Description
0x50000304	DCDC_CTRL1_REG	DCDC First Control Register
0x50000308	DCDC_CTRL2_REG	DCDC Second Control Register
0x5000030C	DCDC_V14_REG	DCDC V14 Control Register
0x50000310	DCDC_VDD_REG	DCDC VDD Control Register
0x50000314	DCDC_V18_REG	DCDC V18 Control Register
0x50000318	DCDC_V18P_REG	DCDC V18P Control Register
0x50000320	DCDC_STATUS1_REG	DCDC First Status Register
0x50000330	DCDC_IRQ_STATUS_REG	DCDC Interrupt Status Register
0x50000334	DCDC_IRQ_CLEAR_REG	DCDC Interrupt Clear Register
0x50000338	DCDC_IRQ_MASK_REG	DCDC Interrupt Mask Register

Table 818: DCDC_CTRL1_REG (0x50000304)

Bit	Mode	Symbol	Description	Reset
31	R/W	DCDC_SH_ENABLE	Enables sample and hold circuit in output comparators.	0x1
30:26	R/W	DCDC_STARTUP_DELAY	Delay between turning bias on and converter becoming active 0 - 31 us, 1 us step size	0xA
25:20	R/W	DCDC_IDLE_MAX_FAST_DOWNRAMP	Maximum output idle time for fast current limit downramping. 0 - 7875 ns, 125 ns step size	0x20
19:15	R/W	DCDC_SW_TIMEOUT	P and N switch timeout, if switch is closed longer than this a timeout is generated and the FSM is forced to the next state Writing 0 disables timeout functionality 62.5 - 1937.5 ns, 62.5 ns step size	0x10
14	R/W	DCDC_FAST_STARTUP	Set current limit to maximum during initial startup	0x0
13	R/W	DCDC_MAN_LV_MODE	Manually activates low voltage settings	0x0
12	R/W	DCDC_AUTO_LV_MODE	Switches to low voltage settings when battery voltage drops below 2.5 V	0x1

Bit	Mode	Symbol	Description	Reset
11:10	R/W	DCDC_IDLE_CLK_DIV	Idle Clock Divider 00 = 2 01 = 4 10 = 8 11 = 16	0x1
9:2	R/W	DCDC_PRIORITY	Charge priority register (4x 2 bit ID) Charge sequence is [1:0] > [3:2] > [5:4] > [7:6] V14 = 00 V18 = 01 VDD = 10 V18P = 11	0xB4
1	R/W	DCDC_FW_ENABLE	Freewheel switch enable	0x0
0	R/W	DCDC_ENABLE	Enable setting for DCDC converter	0x0

Table 819: DCDC_CTRL2_REG (0x50000308)

Bit	Mode	Symbol	Description	Reset
27:24	R/W	DCDC_V_NOK_CNT_MAX	Maximum number of V_NOK events on an output before V_AVAILABLE is reset	0x8
23	R	-	Reserved	0x0
22	R/W	DCDC_N_COMP_TRIM_MAN	Enables manual trimming for N side comparator	0x0
21:16	R/W	DCDC_N_COMP_TRIM_VAL	Manual trim value for N side comparator Signed magnitude representation 011111 = +13 mV 000000 = 100000 = -22 mV 111111 = -56 mV	0x8
15:12	R/W	DCDC_TIMEOUT_IRQ_TRIG	Number of timeout events before timeout interrupt is generated	0x8
11:8	R/W	DCDC_TIMEOUT_IRQ_RES	Number of successive non-timed out charge events required to clear timeout event counter	0x8
7:6	R/W	DCDC_SLOPE_CONTROL	Sets strength of N and P switch drivers	0x3
5:4	R/W	DCDC_VBTSTRP_TRIM	Trim bootstrap voltage $V = 1.6 V + 100 mV * N$	0x1
3:2	R/W	DCDC_LSSUP_TRIM	Trim low side supply voltage $V = 2 V + 300 mV * N$	0x3
1:0	R/W	DCDC_HSGND_TRIM	Trim high side ground $V = V_{BAT} - (2 V + 400 mV * N)$	0x3

Table 820: DCDC_V14_REG (0x5000030C)

Bit	Mode	Symbol	Description	Reset
31	R/W	DCDC_V14_FAST_RAMPING	Fast current ramping (improves response time at the cost of more ripple)	0x0
30:28	R	-	Reserved	0x0

Bit	Mode	Symbol	Description	Reset
27	R/W	DCDC_V14_TRIM	Output voltage trim 1.4 V at trim setting 0x0, steps of 25 mV	0x0
26:22	R/W	DCDC_V14_CUR_LIM_MAX_HV	Maximum current limit (high battery voltage mode) $I = 30 \text{ mA} * (1 + N)$	0xD
21:17	R/W	DCDC_V14_CUR_LIM_MAX_LV	Maximum current limit (low battery voltage mode) $I = 30 \text{ mA} * (1 + N)$	0x6
16:12	R/W	DCDC_V14_CUR_LIM_MIN	Minimum current limit $I = 30 \text{ mA} * (1 + N)$	0x4
11:7	R/W	DCDC_V14_IDLE_HYST	Idle time hysteresis 0 - 3875 ns, 125 ns step size IDLE_MAX = IDLE_MIN + IDLE_HYST Maximum idle time before decreasing CUR_LIM	0x4
6:2	R/W	DCDC_V14_IDLE_MIN	Minimum idle time 0 - 3875 ns, 125 ns step size Minimum idle time, CUR_LIM is increased if this limit is not reached	0x10
1	R/W	DCDC_V14_ENABLE_HV	Output enable (high battery voltage mode) 0 = Disabled 1 = Enabled	0x1
0	R/W	DCDC_V14_ENABLE_LV	Output enable (low battery voltage mode) 0 = Disabled 1 = Enabled	0x1

Table 821: DCDC_VDD_REG (0x50000310)

Bit	Mode	Symbol	Description	Reset
31	R/W	DCDC_VDD_FAST_RAMPING	Fast current ramping (improves response time at the cost of more ripple)	0x0
30	R	-	Reserved	0x0
29:27	R/W	DCDC_VDD_TRIM	Output voltage trim 1.2 V at trim setting 0x4, steps of 25 mV	0x4
26:22	R/W	DCDC_VDD_CUR_LIM_MAX_HV	Maximum current limit (high battery voltage mode) $I = 30 \text{ mA} * (1 + N)$	0x18
21:17	R/W	DCDC_VDD_CUR_LIM_MAX_LV	Maximum current limit (low battery voltage mode) $I = 30 \text{ mA} * (1 + N)$	0xD
16:12	R/W	DCDC_VDD_CUR_LIM_MIN	Minimum current limit $I = 30 \text{ mA} * (1 + N)$	0x4
11:7	R/W	DCDC_VDD_IDLE_HYST	Idle time hysteresis 0 - 3875 ns, 125 ns step size IDLE_MAX = IDLE_MIN + IDLE_HYST Maximum idle time before decreasing CUR_LIM	0x4
6:2	R/W	DCDC_VDD_IDLE_MIN	Minimum idle time 0 - 3875 ns, 125 ns step size	0x10

Bit	Mode	Symbol	Description	Reset
			Minimum idle time, CUR_LIM is increased if this limit is not reached	
1	R/W	DCDC_VDD_ENABLE_HV	Output enable (high battery voltage mode) 0 = Disabled 1 = Enabled	0x1
0	R/W	DCDC_VDD_ENABLE_LV	Output enable (low battery voltage mode) 0 = Disabled 1 = Enabled	0x1

Table 822: DCDC_V18_REG (0x50000314)

Bit	Mode	Symbol	Description	Reset
31	R/W	DCDC_V18_FAST_RAMPING	Fast current ramping (improves response time at the cost of more ripple)	0x0
30:27	R/W	DCDC_V18_TRIM	Output voltage trim 1.8 V at trim setting 0x8, steps of 25 mV	0x8
26:22	R/W	DCDC_V18_CUR_LIM_MAX_HV	Maximum current limit (high battery voltage mode) $I = 30 \text{ mA} * (1 + N)$	0x1F
21:17	R/W	DCDC_V18_CUR_LIM_MAX_LV	Maximum current limit (low battery voltage mode) $I = 30 \text{ mA} * (1 + N)$	0x1F
16:12	R/W	DCDC_V18_CUR_LIM_MIN	Minimum current limit $I = 30 \text{ mA} * (1 + N)$	0x4
11:7	R/W	DCDC_V18_IDLE_HYST	Idle time hysteresis 0 - 3875 ns, 125 ns step size $IDLE_MAX = IDLE_MIN + IDLE_HYST$ Maximum idle time before decreasing CUR_LIM	0x4
6:2	R/W	DCDC_V18_IDLE_MIN	Minimum idle time 0 - 3875 ns, 125 ns step size Minimum idle time, CUR_LIM is increased if this limit is not reached	0x10
1	R/W	DCDC_V18_ENABLE_HV	Output enable (high battery voltage mode) 0 = Disabled 1 = Enabled	0x1
0	R/W	DCDC_V18_ENABLE_LV	Output enable (low battery voltage mode) 0 = Disabled 1 = Enabled	0x0

Table 823: DCDC_V18P_REG (0x50000318)

Bit	Mode	Symbol	Description	Reset
31	R/W	DCDC_V18P_FAST_RAMPING	Fast current ramping (improves response time at the cost of more ripple)	0x0
30:27	R/W	DCDC_V18P_TRIM	Output voltage trim 1.8 V at trim setting 0x8, steps of 25 mV	0x8

Bit	Mode	Symbol	Description	Reset
26:22	R/W	DCDC_V18P_CUR_LI M_MAX_HV	Maximum current limit (high battery voltage mode) $I = 30 \text{ mA} * (1 + N)$	0x1F
21:17	R/W	DCDC_V18P_CUR_LI M_MAX_LV	Maximum current limit (low battery voltage mode) $I = 30 \text{ mA} * (1 + N)$	0x1F
16:12	R/W	DCDC_V18P_CUR_LI M_MIN	Minimum current limit $I = 30 \text{ mA} * (1 + N)$	0x4
11:7	R/W	DCDC_V18P_IDLE_H YST	Idle time hysteresis 0 - 3875 ns, 125 ns step size IDLE_MAX = IDLE_MIN + IDLE_HYST Maximum idle time before decreasing CUR_LIM	0x4
6:2	R/W	DCDC_V18P_IDLE_MI N	Minimum idle time 0 - 3875 ns, 125 ns step size Minimum idle time, CUR_LIM is increased if this limit is not reached	0x10
1	R/W	DCDC_V18P_ENABL E_HV	Output enable (high battery voltage mode) 0 = Disabled 1 = Enabled	0x1
0	R/W	DCDC_V18P_ENABL E_LV	Output enable (low battery voltage mode) 0 = Disabled 1 = Enabled	0x0

Table 824: DCDC_STATUS1_REG (0x50000320)

Bit	Mode	Symbol	Description	Reset
27	R	DCDC_V18P_AVAILA BLE	Indicates whether V18P is available Requires that converter is enabled, output is enabled and V_OK has occurred. Reset when too many V_NOK events have occurred.	0x0
26	R	DCDC_VDD_AVAILAB LE	Indicates whether VDD is available Requires that converter is enabled, output is enabled and V_OK has occurred. Reset when too many V_NOK events have occurred.	0x0
25	R	DCDC_V18_AVAILAB LE	Indicates whether V18 is available Requires that converter is enabled, output is enabled and V_OK has occurred. Reset when too many V_NOK events have occurred.	0x0
24	R	DCDC_V14_AVAILAB LE	Indicates whether V14 is available Requires that converter is enabled, output is enabled and V_OK has occurred. Reset when too many V_NOK events have occurred.	0x0
23	R	DCDC_V18P_COMP_ OK	OK output of V18P comparator	0x0
22	R	DCDC_VDD_COMP_ OK	OK output of VDD comparator	0x0
21	R	DCDC_V18_COMP_O K	OK output of V18 comparator	0x0
20	R	DCDC_V14_COMP_O K	OK output of V14 comparator	0x0

Bit	Mode	Symbol	Description	Reset
19	R	DCDC_V18P_COMP_NOK	NOK output of V18P comparator	0x0
18	R	DCDC_VDD_COMP_NOK	NOK output of VDD comparator	0x0
17	R	DCDC_V18_COMP_NOK	NOK output of V18 comparator	0x0
16	R	DCDC_V14_COMP_NOK	NOK output of V14 comparator	0x0
15:12	R	-	Reserved	0x0
11	R	DCDC_N_COMP_P	DCDC N side dynamic comparator P output	0x0
10	R	DCDC_N_COMP_N	DCDC N side dynamic comparator N output	0x0
9	R	DCDC_P_COMP	DCDC P side continuous time comparator output	0x0
8	R	DCDC_N_COMP	DCDC N side continuous time comparator output	0x0
7	R	DCDC_LV_MODE	Indicates if the converter is in low battery voltage mode	0x0
6	R	DCDC_V18P_SW_STATE	DCDC state machine V18P output	0x0
5	R	DCDC_VDD_SW_STATE	DCDC state machine VDD output	0x0
4	R	DCDC_V18_SW_STATE	DCDC state machine V18 output	0x0
3	R	DCDC_V14_SW_STATE	DCDC state machine V14 output	0x0
2	R	DCDC_N_SW_STATE	DCDC state machine NSW output	0x0
1	R	DCDC_P_SW_STATE	DCDC state machine PSW output	0x0
0	R	DCDC_STARTUP_COMPLETE	Indicates if the converter is enabled and the startup counter has expired (internal biasing settled)	0x0

Table 825: DCDC_IRQ_STATUS_REG (0x50000330)

Bit	Mode	Symbol	Description	Reset
4	R	DCDC_LOW_VBAT_IRQ_STATUS	Low VBAT detector triggered (battery voltage below 2.5 V)	0x0
3	R	DCDC_V18P_TIMEOUT_IRQ_STATUS	Timeout occurred on V18P output	0x0
2	R	DCDC_VDD_TIMEOUT_IRQ_STATUS	Timeout occurred on VDD output	0x0
1	R	DCDC_V18_TIMEOUT_IRQ_STATUS	Timeout occurred on V18 output	0x0
0	R	DCDC_V14_TIMEOUT_IRQ_STATUS	Timeout occurred on V14 output	0x0

Table 826: DCDC_IRQ_CLEAR_REG (0x50000334)

Bit	Mode	Symbol	Description	Reset
4	R0/W	DCDC_LOW_VBAT_IRQ_CLEAR	Clear low VBAT interrupt	0x0

Bit	Mode	Symbol	Description	Reset
3	R0/W	DCDC_V18P_TIMEOU T_IRQ_CLEAR	Clear V18P timeout interrupt	0x0
2	R0/W	DCDC_VDD_TIMEOU T_IRQ_CLEAR	Clear VDD timeout interrupt	0x0
1	R0/W	DCDC_V18_TIMEOUT _IRQ_CLEAR	Clear V18 timeout interrupt	0x0
0	R0/W	DCDC_V14_TIMEOUT _IRQ_CLEAR	Clear V14 timeout interrupt	0x0

Table 827: DCDC_IRQ_MASK_REG (0x50000338)

Bit	Mode	Symbol	Description	Reset
4	R/W	DCDC_LOW_VBAT_I RQ_MASK	Mask low VBAT interrupt	0x0
3	R/W	DCDC_V18P_TIMEOU T_IRQ_MASK	Mask V18P timeout interrupt	0x1
2	R/W	DCDC_VDD_TIMEOU T_IRQ_MASK	Mask VDD timeout interrupt	0x1
1	R/W	DCDC_V18_TIMEOUT _IRQ_MASK	Mask V18 timeout interrupt	0x1
0	R/W	DCDC_V14_TIMEOUT _IRQ_MASK	Mask V14 timeout interrupt	0x1

42.27 DMA Controller Registers

Table 828: Register map DMA

Address	Register	Description
0x50040800	DMA0_A_START_REG	Start address A of DMA channel 0
0x50040804	DMA0_B_START_REG	Start address B of DMA channel 0
0x50040808	DMA0_INT_REG	DMA receive interrupt register channel 0
0x5004080C	DMA0_LEN_REG	DMA receive length register channel 0
0x50040810	DMA0_CTRL_REG	Control register for the DMA channel 0
0x50040814	DMA0_IDX_REG	Index value of DMA channel 0
0x50040820	DMA1_A_START_REG	Start address A of DMA channel 1
0x50040824	DMA1_B_START_REG	Start address B of DMA channel 1
0x50040828	DMA1_INT_REG	DMA receive interrupt register channel 1
0x5004082C	DMA1_LEN_REG	DMA receive length register channel 1
0x50040830	DMA1_CTRL_REG	Control register for the DMA channel 1
0x50040834	DMA1_IDX_REG	Index value of DMA channel 1
0x50040840	DMA2_A_START_REG	Start address A of DMA channel 2
0x50040844	DMA2_B_START_REG	Start address B of DMA channel 2
0x50040848	DMA2_INT_REG	DMA receive interrupt register channel 2
0x5004084C	DMA2_LEN_REG	DMA receive length register channel 2

Address	Register	Description
0x50040850	DMA2_CTRL_REG	Control register for the DMA channel 2
0x50040854	DMA2_IDX_REG	Index value of DMA channel 2
0x50040860	DMA3_A_START_REG	Start address A of DMA channel 3
0x50040864	DMA3_B_START_REG	Start address B of DMA channel 3
0x50040868	DMA3_INT_REG	DMA receive interrupt register channel 3
0x5004086C	DMA3_LEN_REG	DMA receive length register channel 3
0x50040870	DMA3_CTRL_REG	Control register for the DMA channel 3
0x50040874	DMA3_IDX_REG	Index value of DMA channel 3
0x50040880	DMA4_A_START_REG	Start address A of DMA channel 4
0x50040884	DMA4_B_START_REG	Start address B of DMA channel 4
0x50040888	DMA4_INT_REG	DMA receive interrupt register channel 4
0x5004088C	DMA4_LEN_REG	DMA receive length register channel 4
0x50040890	DMA4_CTRL_REG	Control register for the DMA channel 4
0x50040894	DMA4_IDX_REG	Index value of DMA channel 4
0x500408A0	DMA5_A_START_REG	Start address A of DMA channel 5
0x500408A4	DMA5_B_START_REG	Start address B of DMA channel 5
0x500408A8	DMA5_INT_REG	DMA receive interrupt register channel 5
0x500408AC	DMA5_LEN_REG	DMA receive length register channel 5
0x500408B0	DMA5_CTRL_REG	Control register for the DMA channel 5
0x500408B4	DMA5_IDX_REG	Index value of DMA channel 5
0x500408C0	DMA6_A_START_REG	Start address A of DMA channel 6
0x500408C4	DMA6_B_START_REG	Start address B of DMA channel 6
0x500408C8	DMA6_INT_REG	DMA receive interrupt register channel 6
0x500408CC	DMA6_LEN_REG	DMA receive length register channel 6
0x500408D0	DMA6_CTRL_REG	Control register for the DMA channel 6
0x500408D4	DMA6_IDX_REG	Index value of DMA channel 6
0x500408E0	DMA7_A_START_REG	Start address A of DMA channel 7
0x500408E4	DMA7_B_START_REG	Start address B of DMA channel 7
0x500408E8	DMA7_INT_REG	DMA receive interrupt register channel 7
0x500408EC	DMA7_LEN_REG	DMA receive length register channel 7
0x500408F0	DMA7_CTRL_REG	Control register for the DMA channel 7
0x500408F4	DMA7_IDX_REG	Index value of DMA channel 7
0x50040900	DMA_REQ_MUX_REG	DMA channel assignments
0x50040904	DMA_INT_STATUS_REG	DMA interrupt status register
0x50040908	DMA_CLEAR_INT_REG	DMA clear interrupt register
0x5004090C	DMA_INT_MASK_REG	DMA Interrupt mask register

Table 829: [DMA0_A_START_REG \(0x50040800\)](#)

Bit	Mode	Symbol	Description	Reset
31:0	R/W	DMA0_A_START	Source start address	0x0

Table 830: DMA0_B_START_REG (0x50040804)

Bit	Mode	Symbol	Description	Reset
31:0	R/W	DMA0_B_START	Destination start address	0x0

Table 831: DMA0_INT_REG (0x50040808)

Bit	Mode	Symbol	Description	Reset
15:0	R/W	DMA0_INT	Number of transfers until an interrupt is generated. The interrupt is generated after a transfer, if DMAx_INT_REG is equal to DMAx_IDX_REG and before DMAx_IDX_REG is incremented. The bit-field DMA_IRQ_ENABLEx of DMA_INT_MASK_REG must be set to '1' to let the controller generate the interrupt.	0x0

Table 832: DMA0_LEN_REG (0x5004080C)

Bit	Mode	Symbol	Description	Reset
15:0	R/W	DMA0_LEN	DMA channel's transfer length. DMAx_LEN of value 0, 1, 2, ... results into an actual transfer length of 1, 2, 3, ...	0x0

Table 833: DMA0_CTRL_REG (0x50040810)

Bit	Mode	Symbol	Description	Reset
15	R/W	BUS_ERROR_DETECT	0 = Ignores bus error response from the AHB bus, so DMA continues normally. 1 = Detects the bus response and tracks any bus error may occur during the transfer. If a bus error is detected, the channel completes the current read-write DMA cycle (either in burst or single transfers mode) and then closes the transfer, de-asserting DMA_ON bit automatically. It is noted that the respective bus error detection status bit of DMA_INT_STATUS_REG is automatically cleared as soon as the channel is switched-on again, in order to perform a new transfer.	0x1
14:13	R/W	BURST_MODE	Enables the DMA read/write bursts, according to the following configuration: 00 = Bursts are disabled 01 = Bursts of 4 are enabled 10 = Bursts of 8 are enabled 11 = Reserved	0x0
12	R/W	REQ_SENSE	0 = DMA operates with level-sensitive peripheral requests (default) 1 = DMA operates with (positive) edge-sensitive peripheral requests	0x0
11	R/W	DMA_INIT	0 = DMA performs copy A1 to B1, A2 to B2, etc ... 1 = DMA performs copy of A1 to B1, B2, etc ... This feature is useful for memory initialization to any value. Thus, BIN_C must be set to '1', while AIN_C is don't care, as only one fetch from A is done. This process cannot be interrupted by other DMA channels. It is also	0x0

Bit	Mode	Symbol	Description	Reset
			noted that DMA_INIT should not be used when DREQ_MODE='1'.	
10	R/W	DMA_IDLE	0 = Blocking mode, the DMA performs a fast back-to-back copy, disabling bus access for any bus master with lower priority. 1 = Interrupting mode, the DMA inserts a wait cycle after each store allowing the CPU to steal cycles or cache to perform a burst read. If DREQ_MODE='1', DMA_IDLE is don't care.	0x0
9:7	R/W	DMA_PRIO	The priority level determines which DMA channel will be granted access for transferring data, in case more than one channels are active and request the bus at the same time. The greater the value, the higher the priority. In specific: 000 = lowest priority 111 = highest priority If different channels with equal priority level values request the bus at the same time, an inherent priority mechanism is applied. According to this mechanism, if, for example, both the DMA0 and DMA1 channels have the same priority level, then DMA0 will first be granted access to the bus.	0x0
6	R/W	CIRCULAR	0 = Normal mode. The DMA channel stops after having completed the transfer of length determined by DMAx_LEN_REG. DMA_ON automatically deasserts when the transfer is completed. 1 = Circular mode (applicable only if DREQ_MODE = '1'). In this mode, DMA_ON never deasserts, as the DMA channel automatically resets DMAx_IDX_REG and starts a new transfer.	0x0
5	R/W	AINC	Enable increment of source address. 0 = do not increment (source address stays the same during the transfer) 1 = increment according to the value of BW bit-field (by 1, when BW="00" ; by 2, when BW="01" ; by 4, when BW="10")	0x0
4	R/W	BINC	Enable increment of destination address. 0 = do not increment (destination address stays the same during the transfer) 1 = increment according to the value of BW bit-field (by 1, when BW="00" ; by 2, when BW="01" ; by 4, when BW="10")	0x0
3	R/W	DREQ_MODE	0 = DMA channel starts immediately 1 = DMA channel must be triggered by peripheral DMA request (see also the description of DMA_REQ_MUX_REG)	0x0
2:1	R/W	BW	Bus transfer width: 00 = 1 Byte (suggested for peripherals like UART and 8-bit SPI) 01 = 2 Bytes (suggested for peripherals like I2C and 16-bit SPI) 10 = 4 Bytes (suggested for Memory-to-Memory transfers) 11 = Reserved	0x0

Bit	Mode	Symbol	Description	Reset
0	R/W	DMA_ON	<p>0 = DMA channel is off, clocks are disabled 1 = DMA channel is enabled. This bit will be automatically cleared after the completion of a transfer, if circular mode is not enabled. In circular mode, this bit stays set.</p> <p>Note: If DMA_ON is disabled by SW while the DMA channel is active, it cannot be enabled again until the channel has completed the last on-going read-write cycle and has stopped. Thus, the SW has to check that the reading of DMAx_CTRL_REG.DMA_ON returns 0, before setting again the specific bit-field.</p>	0x0

Table 834: DMA0_IDX_REG (0x50040814)

Bit	Mode	Symbol	Description	Reset
15:0	R	DMA0_IDX	<p>This (read-only) register determines the data items already transferred by the DMA channel. Hence, if its value is 1, then the DMA channel has already copied one data item and it is currently performing the next copy. If its value is 2, then two items have already been copied and so on.</p> <p>When the transfer is completed (so when DMAx_CTRL_REG.DMA_ON has been cleared) and DMAx_CTRL_REG.CIRCULAR is not set, the register keeps its (last) value (which should be equal to DMAx_LEN_REG) and it is automatically reset to 0 upon starting a new transfer. In CIRCULAR mode, the register is automatically initialized to 0 as soon as the DMA channel starts-over again.</p>	0x0

Table 835: DMA1_A_START_REG (0x50040820)

Bit	Mode	Symbol	Description	Reset
31:0	R/W	DMA1_A_START	Source start address	0x0

Table 836: DMA1_B_START_REG (0x50040824)

Bit	Mode	Symbol	Description	Reset
31:0	R/W	DMA1_B_START	Destination start address	0x0

Table 837: DMA1_INT_REG (0x50040828)

Bit	Mode	Symbol	Description	Reset
15:0	R/W	DMA1_INT	Number of transfers until an interrupt is generated. The interrupt is generated after a transfer, if DMAx_INT_REG is equal to DMAx_IDX_REG and before DMAx_IDX_REG is incremented. The bit-field DMA_IRQ_ENABLEx of DMA_INT_MASK_REG must be set to '1' to let the controller generate the interrupt.	0x0

Table 838: DMA1_LEN_REG (0x5004082C)

Bit	Mode	Symbol	Description	Reset
15:0	R/W	DMA1_LEN	DMA channel's transfer length. DMAx_LEN of value 0, 1, 2, ... results into an actual transfer length of 1, 2, 3, ...	0x0

Table 839: DMA1_CTRL_REG (0x50040830)

Bit	Mode	Symbol	Description	Reset
15	R/W	BUS_ERROR_DETECT	0 = Ignores bus error response from the AHB bus, so DMA continues normally. 1 = Detects the bus response and tracks any bus error may occur during the transfer. If a bus error is detected, the channel completes the current read-write DMA cycle (either in burst or single transfers mode) and then closes the transfer, de-asserting DMA_ON bit automatically. It is noted that the respective bus error detection status bit of DMA_INT_STATUS_REG is automatically cleared as soon as the channel is switched-on again, in order to perform a new transfer.	0x1
14:13	R/W	BURST_MODE	Enables the DMA read/write bursts, according to the following configuration: 00 = Bursts are disabled 01 = Bursts of 4 are enabled 10 = Bursts of 8 are enabled 11 = Reserved	0x0
12	R/W	REQ_SENSE	0 = DMA operates with level-sensitive peripheral requests (default) 1 = DMA operates with (positive) edge-sensitive peripheral requests	0x0
11	R/W	DMA_INIT	0 = DMA performs copy A1 to B1, A2 to B2, etc ... 1 = DMA performs copy of A1 to B1, B2, etc ... This feature is useful for memory initialization to any value. Thus, BINCR must be set to '1', while AINCR is don't care, as only one fetch from A is done. This process cannot be interrupted by other DMA channels. It is also noted that DMA_INIT should not be used when DREQ_MODE='1'.	0x0
10	R/W	DMA_IDLE	0 = Blocking mode, the DMA performs a fast back-to-back copy, disabling bus access for any bus master with lower priority. 1 = Interrupting mode, the DMA inserts a wait cycle after each store allowing the CPU to steal cycles or cache to perform a burst read. If DREQ_MODE='1', DMA_IDLE is don't care.	0x0
9:7	R/W	DMA_PRIO	The priority level determines which DMA channel will be granted access for transferring data, in case more than one channels are active and request the bus at the same time. The greater the value, the higher the priority. In specific: 000 = lowest priority 111 = highest priority If different channels with equal priority level values request the bus at the same time, an inherent priority mechanism is applied. According to this mechanism, if,	0x0

Bit	Mode	Symbol	Description	Reset
			for example, both the DMA0 and DMA1 channels have the same priority level, then DMA0 will first be granted access to the bus.	
6	R/W	CIRCULAR	0 = Normal mode. The DMA channel stops after having completed the transfer of length determined by DMAx_LEN_REG. DMA_ON automatically deasserts when the transfer is completed. 1 = Circular mode (applicable only if DREQ_MODE = '1'). In this mode, DMA_ON never deasserts, as the DMA channel automatically resets DMAx_IDX_REG and starts a new transfer.	0x0
5	R/W	AINC	Enable increment of source address. 0 = do not increment (source address stays the same during the transfer) 1 = increment according to the value of BW bit-field (by 1, when BW="00" ; by 2, when BW="01" ; by 4, when BW="10")	0x0
4	R/W	BINC	Enable increment of destination address. 0 = do not increment (destination address stays the same during the transfer) 1 = increment according to the value of BW bit-field (by 1, when BW="00" ; by 2, when BW="01" ; by 4, when BW="10")	0x0
3	R/W	DREQ_MODE	0 = DMA channel starts immediately 1 = DMA channel must be triggered by peripheral DMA request (see also the description of DMA_REQ_MUX_REG)	0x0
2:1	R/W	BW	Bus transfer width: 00 = 1 Byte (suggested for peripherals like UART and 8-bit SPI) 01 = 2 Bytes (suggested for peripherals like I2C and 16-bit SPI) 10 = 4 Bytes (suggested for Memory-to-Memory transfers) 11 = Reserved	0x0
0	R/W	DMA_ON	0 = DMA channel is off, clocks are disabled 1 = DMA channel is enabled. This bit will be automatically cleared after the completion of a transfer, if circular mode is not enabled. In circular mode, this bit stays set. Note: If DMA_ON is disabled by SW while the DMA channel is active, it cannot be enabled again until the channel has completed the last on-going read-write cycle and has stopped. Thus, the SW has to check that the reading of DMAx_CTRL_REG.DMA_ON returns 0, before setting again the specific bit-field.	0x0

Table 840: DMA1_IDX_REG (0x50040834)

Bit	Mode	Symbol	Description	Reset
15:0	R	DMA1_IDX	This (read-only) register determines the data items already transferred by the DMA channel. Hence, if its value is 1, then the DMA channel has already copied	0x0

Bit	Mode	Symbol	Description	Reset
			<p>one data item and it is currently performing the next copy. If its value is 2, then two items have already been copied and so on.</p> <p>When the transfer is completed (so when DMAx_CTRL_REG.DMA_ON has been cleared) and DMAx_CTRL_REG.CIRCULAR is not set, the register keeps its (last) value (which should be equal to DMAx_LEN_REG) and it is automatically reset to 0 upon starting a new transfer. In CIRCULAR mode, the register is automatically initialized to 0 as soon as the DMA channel starts-over again.</p>	

Table 841: DMA2_A_START_REG (0x50040840)

Bit	Mode	Symbol	Description	Reset
31:0	R/W	DMA2_A_START	Source start address	0x0

Table 842: DMA2_B_START_REG (0x50040844)

Bit	Mode	Symbol	Description	Reset
31:0	R/W	DMA2_B_START	Destination start address	0x0

Table 843: DMA2_INT_REG (0x50040848)

Bit	Mode	Symbol	Description	Reset
15:0	R/W	DMA2_INT	Number of transfers until an interrupt is generated. The interrupt is generated after a transfer, if DMAx_INT_REG is equal to DMAx_IDX_REG and before DMAx_IDX_REG is incremented. The bit-field DMA_IRQ_ENABLEx of DMA_INT_MASK_REG must be set to '1' to let the controller generate the interrupt.	0x0

Table 844: DMA2_LEN_REG (0x5004084C)

Bit	Mode	Symbol	Description	Reset
15:0	R/W	DMA2_LEN	DMA channel's transfer length. DMAx_LEN of value 0, 1, 2, ... results into an actual transfer length of 1, 2, 3, ...	0x0

Table 845: DMA2_CTRL_REG (0x50040850)

Bit	Mode	Symbol	Description	Reset
15	R/W	BUS_ERROR_DETECT	<p>0 = Ignores bus error response from the AHB bus, so DMA continues normally.</p> <p>1 = Detects the bus response and tracks any bus error may occur during the transfer. If a bus error is detected, the channel completes the current read-write DMA cycle (either in burst or single transfers mode) and then closes the transfer, de-asserting DMA_ON bit automatically.</p> <p>It is noted that the respective bus error detection status bit of DMA_INT_STATUS_REG is automatically cleared as soon as the channel is switched-on again, in order to perform a new transfer.</p>	0x1

Bit	Mode	Symbol	Description	Reset
14:13	R/W	BURST_MODE	Enables the DMA read/write bursts, according to the following configuration: 00 = Bursts are disabled 01 = Bursts of 4 are enabled 10 = Bursts of 8 are enabled 11 = Reserved	0x0
12	R/W	REQ_SENSE	0 = DMA operates with level-sensitive peripheral requests (default) 1 = DMA operates with (positive) edge-sensitive peripheral requests	0x0
11	R/W	DMA_INIT	0 = DMA performs copy A1 to B1, A2 to B2, etc ... 1 = DMA performs copy of A1 to B1, B2, etc ... This feature is useful for memory initialization to any value. Thus, BINC must be set to '1', while AINC is don't care, as only one fetch from A is done. This process cannot be interrupted by other DMA channels. It is also noted that DMA_INIT should not be used when DREQ_MODE='1'.	0x0
10	R/W	DMA_IDLE	0 = Blocking mode, the DMA performs a fast back-to-back copy, disabling bus access for any bus master with lower priority. 1 = Interrupting mode, the DMA inserts a wait cycle after each store allowing the CPU to steal cycles or cache to perform a burst read. If DREQ_MODE='1', DMA_IDLE is don't care.	0x0
9:7	R/W	DMA_PRIO	The priority level determines which DMA channel will be granted access for transferring data, in case more than one channels are active and request the bus at the same time. The greater the value, the higher the priority. In specific: 000 = lowest priority 111 = highest priority If different channels with equal priority level values request the bus at the same time, an inherent priority mechanism is applied. According to this mechanism, if, for example, both the DMA0 and DMA1 channels have the same priority level, then DMA0 will first be granted access to the bus.	0x0
6	R/W	CIRCULAR	0 = Normal mode. The DMA channel stops after having completed the transfer of length determined by DMAx_LEN_REG. DMA_ON automatically deasserts when the transfer is completed. 1 = Circular mode (applicable only if DREQ_MODE = '1'). In this mode, DMA_ON never deasserts, as the DMA channel automatically resets DMAx_IDX_REG and starts a new transfer.	0x0
5	R/W	AINC	Enable increment of destination address. 0 = do not increment (destination address stays the same during the transfer) 1 = increment according to the value of BW bit-field (by 1, when BW="00" ; by 2, when BW="01" ; by 4, when BW="10")	0x0
4	R/W	BINC	Enable increment of destination address	0x0

Bit	Mode	Symbol	Description	Reset
			0 = do not increment 1 = increment according value of BW	
3	R/W	DREQ_MODE	0 = DMA channel starts immediately 1 = DMA channel must be triggered by peripheral DMA request (see also the description of DMA_REQ_MUX_REG)	0x0
2:1	R/W	BW	Bus transfer width: 00 = 1 Byte (suggested for peripherals like UART and 8-bit SPI) 01 = 2 Bytes (suggested for peripherals like I2C and 16-bit SPI) 10 = 4 Bytes (suggested for Memory-to-Memory transfers) 11 = Reserved	0x0
0	R/W	DMA_ON	0 = DMA channel is off, clocks are disabled 1 = DMA channel is enabled. This bit will be automatically cleared after the completion of a transfer, if circular mode is not enabled. In circular mode, this bit stays set. Note: If DMA_ON is disabled by SW while the DMA channel is active, it cannot be enabled again until the channel has completed the last on-going read-write cycle and has stopped. Thus, the SW has to check that the reading of DMAx_CTRL_REG.DMA_ON returns 0, before setting again the specific bit-field.	0x0

Table 846: DMA2_IDX_REG (0x50040854)

Bit	Mode	Symbol	Description	Reset
15:0	R	DMA2_IDX	This (read-only) register determines the data items already transferred by the DMA channel. Hence, if its value is 1, then the DMA channel has already copied one data item and it is currently performing the next copy. If its value is 2, then two items have already been copied and so on. When the transfer is completed (so when DMAx_CTRL_REG.DMA_ON has been cleared) and DMAx_CTRL_REG.CIRCULAR is not set, the register keeps its (last) value (which should be equal to DMAx_LEN_REG) and it is automatically reset to 0 upon starting a new transfer. In CIRCULAR mode, the register is automatically initialized to 0 as soon as the DMA channel starts-over again.	0x0

Table 847: DMA3_A_START_REG (0x50040860)

Bit	Mode	Symbol	Description	Reset
31:0	R/W	DMA3_A_START	Source start address	0x0

Table 848: DMA3_B_START_REG (0x50040864)

Bit	Mode	Symbol	Description	Reset
31:0	R/W	DMA3_B_START	Destination start address	0x0

Table 849: DMA3_INT_REG (0x50040868)

Bit	Mode	Symbol	Description	Reset
15:0	R/W	DMA3_INT	Number of transfers until an interrupt is generated. The interrupt is generated after a transfer, if DMAx_INT_REG is equal to DMAx_IDX_REG and before DMAx_IDX_REG is incremented. The bit-field DMA_IRQ_ENABLEx of DMA_INT_MASK_REG must be set to '1' to let the controller generate the interrupt.	0x0

Table 850: DMA3_LEN_REG (0x5004086C)

Bit	Mode	Symbol	Description	Reset
15:0	R/W	DMA3_LEN	DMA channel's transfer length. DMAx_LEN of value 0, 1, 2, ... results into an actual transfer length of 1, 2, 3, ...	0x0

Table 851: DMA3_CTRL_REG (0x50040870)

Bit	Mode	Symbol	Description	Reset
15	R/W	BUS_ERROR_DETECT	0 = Ignores bus error response from the AHB bus, so DMA continues normally. 1 = Detects the bus response and tracks any bus error may occur during the transfer. If a bus error is detected, the channel completes the current read-write DMA cycle (either in burst or single transfers mode) and then closes the transfer, de-asserting DMA_ON bit automatically. It is noted that the respective bus error detection status bit of DMA_INT_STATUS_REG is automatically cleared as soon as the channel is switched-on again, in order to perform a new transfer.	0x1
14:13	R/W	BURST_MODE	Enables the DMA read/write bursts, according to the following configuration: 00 = Bursts are disabled 01 = Bursts of 4 are enabled 10 = Bursts of 8 are enabled 11 = Reserved	0x0
12	R/W	REQ_SENSE	0 = DMA operates with level-sensitive peripheral requests (default) 1 = DMA operates with (positive) edge-sensitive peripheral requests	0x0
11	R/W	DMA_INIT	0 = DMA performs copy A1 to B1, A2 to B2, etc ... 1 = DMA performs copy of A1 to B1, B2, etc ... This feature is useful for memory initialization to any value. Thus, BINC must be set to '1', while AINC is don't care, as only one fetch from A is done. This process cannot be interrupted by other DMA channels. It is also noted that DMA_INIT should not be used when DREQ_MODE='1'.	0x0

Bit	Mode	Symbol	Description	Reset
10	R/W	DMA_IDLE	0 = Blocking mode, the DMA performs a fast back-to-back copy, disabling bus access for any bus master with lower priority. 1 = Interrupting mode, the DMA inserts a wait cycle after each store allowing the CPU to steal cycles or cache to perform a burst read. If DREQ_MODE='1', DMA_IDLE is don't care.	0x0
9:7	R/W	DMA_PRIO	The priority level determines which DMA channel will be granted access for transferring data, in case more than one channels are active and request the bus at the same time. The greater the value, the higher the priority. In specific: 000 = lowest priority 111 = highest priority If different channels with equal priority level values request the bus at the same time, an inherent priority mechanism is applied. According to this mechanism, if, for example, both the DMA0 and DMA1 channels have the same priority level, then DMA0 will first be granted access to the bus.	0x0
6	R/W	CIRCULAR	0 = Normal mode. The DMA channel stops after having completed the transfer of length determined by DMAx_LEN_REG. DMA_ON automatically deasserts when the transfer is completed. 1 = Circular mode (applicable only if DREQ_MODE = '1'). In this mode, DMA_ON never deasserts, as the DMA channel automatically resets DMAx_IDX_REG and starts a new transfer.	0x0
5	R/W	AINC	Enable increment of source address. 0 = do not increment (source address stays the same during the transfer) 1 = increment according to the value of BW bit-field (by 1, when BW="00" ; by 2, when BW="01" ; by 4, when BW="10")	0x0
4	R/W	BINC	Enable increment of destination address. 0 = do not increment (destination address stays the same during the transfer) 1 = increment according to the value of BW bit-field (by 1, when BW="00" ; by 2, when BW="01" ; by 4, when BW="10")	0x0
3	R/W	DREQ_MODE	0 = DMA channel starts immediately 1 = DMA channel must be triggered by peripheral DMA request (see also the description of DMA_REQ_MUX_REG)	0x0
2:1	R/W	BW	Bus transfer width: 00 = 1 Byte (suggested for peripherals like UART and 8-bit SPI) 01 = 2 Bytes (suggested for peripherals like I2C and 16-bit SPI) 10 = 4 Bytes (suggested for Memory-to-Memory transfers) 11 = Reserved	0x0
0	R/W	DMA_ON	0 = DMA channel is off, clocks are disabled	0x0

Bit	Mode	Symbol	Description	Reset
			<p>1 = DMA channel is enabled. This bit will be automatically cleared after the completion of a transfer, if circular mode is not enabled. In circular mode, this bit stays set.</p> <p>Note: If DMA_ON is disabled by SW while the DMA channel is active, it cannot be enabled again until the channel has completed the last on-going read-write cycle and has stopped. Thus, the SW has to check that the reading of DMAx_CTRL_REG.DMA_ON returns 0, before setting again the specific bit-field.</p>	

Table 852: DMA3_IDX_REG (0x50040874)

Bit	Mode	Symbol	Description	Reset
15:0	R	DMA3_IDX	<p>This (read-only) register determines the data items already transferred by the DMA channel. Hence, if its value is 1, then the DMA channel has already copied one data item and it is currently performing the next copy. If its value is 2, then two items have already been copied and so on.</p> <p>When the transfer is completed (so when DMAx_CTRL_REG.DMA_ON has been cleared) and DMAx_CTRL_REG.CIRCULAR is not set, the register keeps its (last) value (which should be equal to DMAx_LEN_REG) and it is automatically reset to 0 upon starting a new transfer. In CIRCULAR mode, the register is automatically initialized to 0 as soon as the DMA channel starts-over again.</p>	0x0

Table 853: DMA4_A_START_REG (0x50040880)

Bit	Mode	Symbol	Description	Reset
31:0	R/W	DMA4_A_START	Source start address	0x0

Table 854: DMA4_B_START_REG (0x50040884)

Bit	Mode	Symbol	Description	Reset
31:0	R/W	DMA4_B_START	Destination start address	0x0

Table 855: DMA4_INT_REG (0x50040888)

Bit	Mode	Symbol	Description	Reset
15:0	R/W	DMA4_INT	Number of transfers until an interrupt is generated. The interrupt is generated after a transfer, if DMAx_INT_REG is equal to DMAx_IDX_REG and before DMAx_IDX_REG is incremented. The bit-field DMA_IRQ_ENABLEx of DMA_INT_MASK_REG must be set to '1' to let the controller generate the interrupt.	0x0

Table 856: DMA4_LEN_REG (0x5004088C)

Bit	Mode	Symbol	Description	Reset
15:0	R/W	DMA4_LEN	DMA channel's transfer length. DMAx_LEN of value 0, 1, 2, ... results into an actual transfer length of 1, 2, 3, ...	0x0

Table 857: DMA4_CTRL_REG (0x50040890)

Bit	Mode	Symbol	Description	Reset
15	R/W	BUS_ERROR_DETECT	0 = Ignores bus error response from the AHB bus, so DMA continues normally. 1 = Detects the bus response and tracks any bus error may occur during the transfer. If a bus error is detected, the channel completes the current read-write DMA cycle (either in burst or single transfers mode) and then closes the transfer, de-asserting DMA_ON bit automatically. It is noted that the respective bus error detection status bit of DMA_INT_STATUS_REG is automatically cleared as soon as the channel is switched-on again, in order to perform a new transfer.	0x1
14:13	R/W	BURST_MODE	Enables the DMA read/write bursts, according to the following configuration: 00 = Bursts are disabled 01 = Bursts of 4 are enabled 10 = Bursts of 8 are enabled 11 = Reserved	0x0
12	R/W	REQ_SENSE	0 = DMA operates with level-sensitive peripheral requests (default) 1 = DMA operates with (positive) edge-sensitive peripheral requests	0x0
11	R/W	DMA_INIT	0 = DMA performs copy A1 to B1, A2 to B2, etc ... 1 = DMA performs copy of A1 to B1, B2, etc ... This feature is useful for memory initialization to any value. Thus, BINCC must be set to '1', while AINC is don't care, as only one fetch from A is done. This process cannot be interrupted by other DMA channels. It is also noted that DMA_INIT should not be used when DREQ_MODE='1'.	0x0
10	R/W	DMA_IDLE	0 = Blocking mode, the DMA performs a fast back-to-back copy, disabling bus access for any bus master with lower priority. 1 = Interrupting mode, the DMA inserts a wait cycle after each store allowing the CPU to steal cycles or cache to perform a burst read. If DREQ_MODE='1', DMA_IDLE is don't care.	0x0
9:7	R/W	DMA_PRIO	The priority level determines which DMA channel will be granted access for transferring data, in case more than one channels are active and request the bus at the same time. The greater the value, the higher the priority. In specific: 000 = lowest priority 111 = highest priority If different channels with equal priority level values request the bus at the same time, an inherent priority mechanism is applied. According to this mechanism, if,	0x0

Bit	Mode	Symbol	Description	Reset
			for example, both the DMA0 and DMA1 channels have the same priority level, then DMA0 will first be granted access to the bus.	
6	R/W	CIRCULAR	0 = Normal mode. The DMA channel stops after having completed the transfer of length determined by DMAx_LEN_REG. DMA_ON automatically deasserts when the transfer is completed. 1 = Circular mode (applicable only if DREQ_MODE = '1'). In this mode, DMA_ON never deasserts, as the DMA channel automatically resets DMAx_IDX_REG and starts a new transfer.	0x0
5	R/W	AINC	Enable increment of source address. 0 = do not increment (source address stays the same during the transfer) 1 = increment according to the value of BW bit-field (by 1, when BW="00" ; by 2, when BW="01" ; by 4, when BW="10")	0x0
4	R/W	BINC	Enable increment of destination address. 0 = do not increment (destination address stays the same during the transfer) 1 = increment according to the value of BW bit-field (by 1, when BW="00" ; by 2, when BW="01" ; by 4, when BW="10")	0x0
3	R/W	DREQ_MODE	0 = DMA channel starts immediately 1 = DMA channel must be triggered by peripheral DMA request (see also the description of DMA_REQ_MUX_REG)	0x0
2:1	R/W	BW	Bus transfer width: 00 = 1 Byte (suggested for peripherals like UART and 8-bit SPI) 01 = 2 Bytes (suggested for peripherals like I2C and 16-bit SPI) 10 = 4 Bytes (suggested for Memory-to-Memory transfers) 11 = Reserved	0x0
0	R/W	DMA_ON	0 = DMA channel is off, clocks are disabled 1 = DMA channel is enabled. This bit will be automatically cleared after the completion of a transfer, if circular mode is not enabled. In circular mode, this bit stays set. Note: If DMA_ON is disabled by SW while the DMA channel is active, it cannot be enabled again until the channel has completed the last on-going read-write cycle and has stopped. Thus, the SW has to check that the reading of DMAx_CTRL_REG.DMA_ON returns 0, before setting again the specific bit-field.	0x0

Table 858: DMA4_IDX_REG (0x50040894)

Bit	Mode	Symbol	Description	Reset
15:0	R	DMA4_IDX	This (read-only) register determines the data items already transferred by the DMA channel. Hence, if its value is 1, then the DMA channel has already copied	0x0

Bit	Mode	Symbol	Description	Reset
			<p>one data item and it is currently performing the next copy. If its value is 2, then two items have already been copied and so on.</p> <p>When the transfer is completed (so when DMAx_CTRL_REG.DMA_ON has been cleared) and DMAx_CTRL_REG.CIRCULAR is not set, the register keeps its (last) value (which should be equal to DMAx_LEN_REG) and it is automatically reset to 0 upon starting a new transfer. In CIRCULAR mode, the register is automatically initialized to 0 as soon as the DMA channel starts-over again.</p>	

Table 859: DMA5_A_START_REG (0x500408A0)

Bit	Mode	Symbol	Description	Reset
31:0	R/W	DMA5_A_START	Source start address	0x0

Table 860: DMA5_B_START_REG (0x500408A4)

Bit	Mode	Symbol	Description	Reset
31:0	R/W	DMA5_B_START	Destination start address	0x0

Table 861: DMA5_INT_REG (0x500408A8)

Bit	Mode	Symbol	Description	Reset
15:0	R/W	DMA5_INT	Number of transfers until an interrupt is generated. The interrupt is generated after a transfer, if DMAx_INT_REG is equal to DMAx_IDX_REG and before DMAx_IDX_REG is incremented. The bit-field DMA_IRQ_ENABLEx of DMA_INT_MASK_REG must be set to '1' to let the controller generate the interrupt.	0x0

Table 862: DMA5_LEN_REG (0x500408AC)

Bit	Mode	Symbol	Description	Reset
15:0	R/W	DMA5_LEN	DMA channel's transfer length. DMAx_LEN of value 0, 1, 2, ... results into an actual transfer length of 1, 2, 3, ...	0x0

Table 863: DMA5_CTRL_REG (0x500408B0)

Bit	Mode	Symbol	Description	Reset
15	R/W	BUS_ERROR_DETECT	<p>0 = Ignores bus error response from the AHB bus, so DMA continues normally.</p> <p>1 = Detects the bus response and tracks any bus error may occur during the transfer. If a bus error is detected, the channel completes the current read-write DMA cycle (either in burst or single transfers mode) and then closes the transfer, de-asserting DMA_ON bit automatically.</p> <p>It is noted that the respective bus error detection status bit of DMA_INT_STATUS_REG is automatically cleared as soon as the channel is switched-on again, in order to perform a new transfer.</p>	0x1

Bit	Mode	Symbol	Description	Reset
14:13	R/W	BURST_MODE	Enables the DMA read/write bursts, according to the following configuration: 00 = Bursts are disabled 01 = Bursts of 4 are enabled 10 = Bursts of 8 are enabled 11 = Reserved	0x0
12	R/W	REQ_SENSE	0 = DMA operates with level-sensitive peripheral requests (default) 1 = DMA operates with (positive) edge-sensitive peripheral requests	0x0
11	R/W	DMA_INIT	0 = DMA performs copy A1 to B1, A2 to B2, etc ... 1 = DMA performs copy of A1 to B1, B2, etc ... This feature is useful for memory initialization to any value. Thus, BINC must be set to '1', while AINC is don't care, as only one fetch from A is done. This process cannot be interrupted by other DMA channels. It is also noted that DMA_INIT should not be used when DREQ_MODE='1'.	0x0
10	R/W	DMA_IDLE	0 = Blocking mode, the DMA performs a fast back-to-back copy, disabling bus access for any bus master with lower priority. 1 = Interrupting mode, the DMA inserts a wait cycle after each store allowing the CPU to steal cycles or cache to perform a burst read. If DREQ_MODE='1', DMA_IDLE is don't care.	0x0
9:7	R/W	DMA_PRIO	The priority level determines which DMA channel will be granted access for transferring data, in case more than one channels are active and request the bus at the same time. The greater the value, the higher the priority. In specific: 000 = lowest priority 111 = highest priority If different channels with equal priority level values request the bus at the same time, an inherent priority mechanism is applied. According to this mechanism, if, for example, both the DMA0 and DMA1 channels have the same priority level, then DMA0 will first be granted access to the bus.	0x0
6	R/W	CIRCULAR	0 = Normal mode. The DMA channel stops after having completed the transfer of length determined by DMAx_LEN_REG. DMA_ON automatically deasserts when the transfer is completed. 1 = Circular mode (applicable only if DREQ_MODE = '1'). In this mode, DMA_ON never deasserts, as the DMA channel automatically resets DMAx_IDX_REG and starts a new transfer.	0x0
5	R/W	AINC	Enable increment of source address. 0 = do not increment (source address stays the same during the transfer) 1 = increment according to the value of BW bit-field (by 1, when BW="00" ; by 2, when BW="01" ; by 4, when BW="10")	0x0
4	R/W	BINC	Enable increment of destination address.	0x0

Bit	Mode	Symbol	Description	Reset
			0 = do not increment (destination address stays the same during the transfer) 1 = increment according to the value of BW bit-field (by 1, when BW="00" ; by 2, when BW="01" ; by 4, when BW="10")	
3	R/W	DREQ_MODE	0 = DMA channel starts immediately 1 = DMA channel must be triggered by peripheral DMA request (see also the description of DMA_REQ_MUX_REG)	0x0
2:1	R/W	BW	Bus transfer width: 00 = 1 Byte (suggested for peripherals like UART and 8-bit SPI) 01 = 2 Bytes (suggested for peripherals like I2C and 16-bit SPI) 10 = 4 Bytes (suggested for Memory-to-Memory transfers) 11 = Reserved	0x0
0	R/W	DMA_ON	0 = DMA channel is off, clocks are disabled 1 = DMA channel is enabled. This bit will be automatically cleared after the completion of a transfer, if circular mode is not enabled. In circular mode, this bit stays set. Note: If DMA_ON is disabled by SW while the DMA channel is active, it cannot be enabled again until the channel has completed the last on-going read-write cycle and has stopped. Thus, the SW has to check that the reading of DMAx_CTRL_REG.DMA_ON returns 0, before setting again the specific bit-field.	0x0

Table 864: DMA5_IDX_REG (0x500408B4)

Bit	Mode	Symbol	Description	Reset
15:0	R	DMA5_IDX	This (read-only) register determines the data items already transferred by the DMA channel. Hence, if its value is 1, then the DMA channel has already copied one data item and it is currently performing the next copy. If its value is 2, then two items have already been copied and so on. When the transfer is completed (so when DMAx_CTRL_REG.DMA_ON has been cleared) and DMAx_CTRL_REG.CIRCULAR is not set, the register keeps its (last) value (which should be equal to DMAx_LEN_REG) and it is automatically reset to 0 upon starting a new transfer. In CIRCULAR mode, the register is automatically initialized to 0 as soon as the DMA channel starts-over again.	0x0

Table 865: DMA6_A_START_REG (0x500408C0)

Bit	Mode	Symbol	Description	Reset
31:0	R/W	DMA6_A_START	Source start address	0x0

Table 866: DMA6_B_START_REG (0x500408C4)

Bit	Mode	Symbol	Description	Reset
31:0	R/W	DMA6_B_START	Destination start address	0x0

Table 867: DMA6_INT_REG (0x500408C8)

Bit	Mode	Symbol	Description	Reset
15:0	R/W	DMA6_INT	Number of transfers until an interrupt is generated. The interrupt is generated after a transfer, if DMAx_INT_REG is equal to DMAx_IDX_REG and before DMAx_IDX_REG is incremented. The bit-field DMA_IRQ_ENABLEx of DMA_INT_MASK_REG must be set to '1' to let the controller generate the interrupt.	0x0

Table 868: DMA6_LEN_REG (0x500408CC)

Bit	Mode	Symbol	Description	Reset
15:0	R/W	DMA6_LEN	DMA channel's transfer length. DMAx_LEN of value 0, 1, 2, ... results into an actual transfer length of 1, 2, 3, ...	0x0

Table 869: DMA6_CTRL_REG (0x500408D0)

Bit	Mode	Symbol	Description	Reset
15	R/W	BUS_ERROR_DETECT	0 = Ignores bus error response from the AHB bus, so DMA continues normally. 1 = Detects the bus response and tracks any bus error may occur during the transfer. If a bus error is detected, the channel completes the current read-write DMA cycle (either in burst or single transfers mode) and then closes the transfer, de-asserting DMA_ON bit automatically. It is noted that the respective bus error detection status bit of DMA_INT_STATUS_REG is automatically cleared as soon as the channel is switched-on again, in order to perform a new transfer.	0x1
14:13	R/W	BURST_MODE	Enables the DMA read/write bursts, according to the following configuration: 00 = Bursts are disabled 01 = Bursts of 4 are enabled 10 = Bursts of 8 are enabled 11 = Reserved	0x0
12	R/W	REQ_SENSE	0 = DMA operates with level-sensitive peripheral requests (default) 1 = DMA operates with (positive) edge-sensitive peripheral requests	0x0
11	R/W	DMA_INIT	0 = DMA performs copy A1 to B1, A2 to B2, etc ... 1 = DMA performs copy of A1 to B1, B2, etc ... This feature is useful for memory initialization to any value. Thus, BINC must be set to '1', while AINC is don't care, as only one fetch from A is done. This process cannot be interrupted by other DMA channels. It is also noted that DMA_INIT should not be used when DREQ_MODE='1'.	0x0

Bit	Mode	Symbol	Description	Reset
10	R/W	DMA_IDLE	0 = Blocking mode, the DMA performs a fast back-to-back copy, disabling bus access for any bus master with lower priority. 1 = Interrupting mode, the DMA inserts a wait cycle after each store allowing the CPU to steal cycles or cache to perform a burst read. If DREQ_MODE='1', DMA_IDLE is don't care.	0x0
9:7	R/W	DMA_PRIO	The priority level determines which DMA channel will be granted access for transferring data, in case more than one channels are active and request the bus at the same time. The greater the value, the higher the priority. In specific: 000 = lowest priority 111 = highest priority If different channels with equal priority level values request the bus at the same time, an inherent priority mechanism is applied. According to this mechanism, if, for example, both the DMA0 and DMA1 channels have the same priority level, then DMA0 will first be granted access to the bus.	0x0
6	R/W	CIRCULAR	0 = Normal mode. The DMA channel stops after having completed the transfer of length determined by DMAx_LEN_REG. DMA_ON automatically deasserts when the transfer is completed. 1 = Circular mode (applicable only if DREQ_MODE = '1'). In this mode, DMA_ON never deasserts, as the DMA channel automatically resets DMAx_IDX_REG and starts a new transfer.	0x0
5	R/W	AINC	Enable increment of source address. 0 = do not increment (source address stays the same during the transfer) 1 = increment according to the value of BW bit-field (by 1, when BW="00" ; by 2, when BW="01" ; by 4, when BW="10")	0x0
4	R/W	BINC	Enable increment of destination address. 0 = do not increment (destination address stays the same during the transfer) 1 = increment according to the value of BW bit-field (by 1, when BW="00" ; by 2, when BW="01" ; by 4, when BW="10")	0x0
3	R/W	DREQ_MODE	0 = DMA channel starts immediately 1 = DMA channel must be triggered by peripheral DMA request (see also the description of DMA_REQ_MUX_REG)	0x0
2:1	R/W	BW	Bus transfer width: 00 = 1 Byte (suggested for peripherals like UART and 8-bit SPI) 01 = 2 Bytes (suggested for peripherals like I2C and 16-bit SPI) 10 = 4 Bytes (suggested for Memory-to-Memory transfers) 11 = Reserved	0x0
0	R/W	DMA_ON	0 = DMA channel is off, clocks are disabled	0x0

Bit	Mode	Symbol	Description	Reset
			<p>1 = DMA channel is enabled. This bit will be automatically cleared after the completion of a transfer, if circular mode is not enabled. In circular mode, this bit stays set.</p> <p>Note: If DMA_ON is disabled by SW while the DMA channel is active, it cannot be enabled again until the channel has completed the last on-going read-write cycle and has stopped. Thus, the SW has to check that the reading of DMAx_CTRL_REG.DMA_ON returns 0, before setting again the specific bit-field.</p>	

Table 870: DMA6_IDX_REG (0x500408D4)

Bit	Mode	Symbol	Description	Reset
15:0	R	DMA6_IDX	<p>This (read-only) register determines the data items already transferred by the DMA channel. Hence, if its value is 1, then the DMA channel has already copied one data item and it is currently performing the next copy. If its value is 2, then two items have already been copied and so on.</p> <p>When the transfer is completed (so when DMAx_CTRL_REG.DMA_ON has been cleared) and DMAx_CTRL_REG.CIRCULAR is not set, the register keeps its (last) value (which should be equal to DMAx_LEN_REG) and it is automatically reset to 0 upon starting a new transfer. In CIRCULAR mode, the register is automatically initialized to 0 as soon as the DMA channel starts-over again.</p>	0x0

Table 871: DMA7_A_START_REG (0x500408E0)

Bit	Mode	Symbol	Description	Reset
31:0	R/W	DMA7_A_START	<p>Source start address</p> <p>NOTE: See also the DMA chapter of the Datasheet for the allowed range of the DMA7 channel's source address in Secure Boot mode.</p>	0x0

Table 872: DMA7_B_START_REG (0x500408E4)

Bit	Mode	Symbol	Description	Reset
31:0	R/W	DMA7_B_START	<p>Destination start address</p> <p>NOTE: See also the DMA chapter of the Datasheet for the allowed range of the DMA7 channel's destination address in Secure Boot mode.</p>	0x0

Table 873: DMA7_INT_REG (0x500408E8)

Bit	Mode	Symbol	Description	Reset
15:0	R/W	DMA7_INT	<p>Number of transfers until an interrupt is generated. The interrupt is generated after a transfer, if DMAx_INT_REG is equal to DMAx_IDX_REG and before DMAx_IDX_REG is incremented. The bit-field</p>	0x0

Bit	Mode	Symbol	Description	Reset
			DMA_IRQ_ENABLE _x of DMA_INT_MASK_REG must be set to '1' to let the controller generate the interrupt.	

Table 874: DMA7_LEN_REG (0x500408EC)

Bit	Mode	Symbol	Description	Reset
15:0	R/W	DMA7_LEN	DMA channel's transfer length. DMA _x _LEN of value 0, 1, 2, ... results into an actual transfer length of 1, 2, 3, ...	0x0

Table 875: DMA7_CTRL_REG (0x500408F0)

Bit	Mode	Symbol	Description	Reset
15	R/W	BUS_ERROR_DETECT	0 = Ignores bus error response from the AHB bus, so DMA continues normally. 1 = Detects the bus response and tracks any bus error may occur during the transfer. If a bus error is detected, the channel completes the current read-write DMA cycle (either in burst or single transfers mode) and then closes the transfer, de-asserting DMA_ON bit automatically. It is noted that the respective bus error detection status bit of DMA_INT_STATUS_REG is automatically cleared as soon as the channel is switched-on again, in order to perform a new transfer. NOTE: In secure boot mode, the bus error detection mode of DMA7 channel is always enabled, overruling the specific bit-field's programmed value.	0x1
14:13	R/W	BURST_MODE	Enables the DMA read/write bursts, according to the following configuration: 00 = Bursts are disabled 01 = Bursts of 4 are enabled 10 = Bursts of 8 are enabled 11 = Reserved	0x0
12	R/W	REQ_SENSE	0 = DMA operates with level-sensitive peripheral requests (default) 1 = DMA operates with (positive) edge-sensitive peripheral requests	0x0
11	R/W	DMA_INIT	0 = DMA performs copy A1 to B1, A2 to B2, etc ... 1 = DMA performs copy of A1 to B1, B2, etc ... This feature is useful for memory initialization to any value. Thus, BINC must be set to '1', while AINC is don't care, as only one fetch from A is done. This process cannot be interrupted by other DMA channels. It is also noted that DMA_INIT should not be used when DREQ_MODE='1'. NOTE: This bit-field is overruled to '0' when the DMA7 channel is configured as "trusted" channel (in Secure Boot mode).	0x0
10	R/W	DMA_IDLE	0 = Blocking mode, the DMA performs a fast back-to-back copy, disabling bus access for any bus master with lower priority. 1 = Interrupting mode, the DMA inserts a wait cycle after each store allowing the CPU to steal cycles or cache to	0x0

Bit	Mode	Symbol	Description	Reset
			perform a burst read. If DREQ_MODE='1', DMA_IDLE is don't care. *NOTE: This bit-field is overruled to '0' when the DMA7 channel is configured as "trusted" channel (in Secure Boot mode).	
9:7	R/W	DMA_PRIO	The priority level determines which DMA channel will be granted access for transferring data, in case more than one channels are active and request the bus at the same time. The greater the value, the higher the priority. In specific: 000 = lowest priority 111 = highest priority If different channels with equal priority level values request the bus at the same time, an inherent priority mechanism is applied. According to this mechanism, if, for example, both the DMA0 and DMA1 channels have the same priority level, then DMA0 will first be granted access to the bus.	0x0
6	R/W	CIRCULAR	0 = Normal mode. The DMA channel stops after having completed the transfer of length determined by DMAx_LEN_REG. DMA_ON automatically deasserts when the transfer is completed. 1 = Circular mode (applicable only if DREQ_MODE = '1'). In this mode, DMA_ON never deasserts, as the DMA channel automatically resets DMAx_IDX_REG and starts a new transfer.	0x0
5	R/W	AINC	Enable increment of source address. 0 = do not increment (source address stays the same during the transfer) 1 = increment according to the value of BW bit-field (by 1, when BW="00" ; by 2, when BW="01" ; by 4, when BW="10")	0x0
4	R/W	BINC	Enable increment of destination address. 0 = do not increment (destination address stays the same during the transfer) 1 = increment according to the value of BW bit-field (by 1, when BW="00" ; by 2, when BW="01" ; by 4, when BW="10")	0x0
3	R/W	DREQ_MODE	0 = DMA channel starts immediately 1 = DMA channel must be triggered by peripheral DMA request (see also the description of DMA_REQ_MUX_REG) *NOTE: This bit-field is overruled to '0' when channel DMA7 is configured as "trusted" channel (in Secure Boot mode).	0x0
2:1	R/W	BW	Bus transfer width: 00 = 1 Byte (suggested for peripherals like UART and 8-bit SPI) 01 = 2 Bytes (suggested for peripherals like I2C and 16-bit SPI) 10 = 4 Bytes (suggested for Memory-to-Memory transfers) 11 = Reserved	0x0

Bit	Mode	Symbol	Description	Reset
			NOTE: This bit-field is overruled to "10" when channel DMA7 is configured as "trusted" channel (in Secure Boot mode).	
0	R/W	DMA_ON	<p>0 = DMA channel is off, clocks are disabled 1 = DMA channel is enabled. This bit will be automatically cleared after the completion of a transfer, if circular mode is not enabled. In circular mode, this bit stays set.</p> <p>Note: If DMA_ON is disabled by SW while the DMA channel is active, it cannot be enabled again until the channel has completed the last on-going read-write cycle and has stopped. Thus, the SW has to check that the reading of DMAx_CTRL_REG.DMA_ON returns 0, before setting again the specific bit-field.</p>	0x0

Table 876: DMA7_IDX_REG (0x500408F4)

Bit	Mode	Symbol	Description	Reset
15:0	R	DMA7_IDX	<p>This (read-only) register determines the data items already transferred by the DMA channel. Hence, if its value is 1, then the DMA channel has already copied one data item and it is currently performing the next copy. If its value is 2, then two items have already been copied and so on.</p> <p>When the transfer is completed (so when DMAx_CTRL_REG.DMA_ON has been cleared) and DMAx_CTRL_REG.CIRCULAR is not set, the register keeps its (last) value (which should be equal to DMAx_LEN_REG) and it is automatically reset to 0 upon starting a new transfer. In CIRCULAR mode, the register is automatically initialized to 0 as soon as the DMA channel starts-over again.</p>	0x0

Table 877: DMA_REQ_MUX_REG (0x50040900)

Bit	Mode	Symbol	Description	Reset
15:12	R/W	DMA67_SEL	<p>Select which combination of peripherals are mapped on the DMA channels. The peripherals are mapped as pairs on two channels.</p> <p>Here, the first DMA request is mapped on channel 6 and the second on channel 7.</p> <p>See DMA01_SEL for the peripheral mapping.</p>	0xF
11:8	R/W	DMA45_SEL	<p>Select which combination of peripherals are mapped on the DMA channels. The peripherals are mapped as pairs on two channels.</p> <p>Here, the first DMA request is mapped on channel 4 and the second on channel 5.</p> <p>See DMA01_SEL for the peripherals' mapping.</p>	0xF
7:4	R/W	DMA23_SEL	<p>Select which combination of peripherals are mapped on the DMA channels. The peripherals are mapped as pairs on two channels.</p> <p>Here, the first DMA request is mapped on channel 2 and the second on channel 3.</p> <p>See DMA01_SEL for the peripherals' mapping.</p>	0xF

Bit	Mode	Symbol	Description	Reset
3:0	R/W	DMA01_SEL	<p>Select which combination of peripherals are mapped on the DMA channels. The peripherals are mapped as pairs on two channels.</p> <p>Here, the first DMA request is mapped on channel 0 and the second on channel 1.</p> <p>0x0: SPI_rx / SPI_tx 0x1: SPI2_rx / SPI2_tx 0x2: UART_rx / UART_tx 0x3: UART2_rx / UART2_tx 0x4: I2C_rx / I2C_tx 0x5: I2C2_rx / I2C2_tx 0x6: USB_rx / USB_tx 0x7: UART3_rx/UART3_tx 0x8: PCM_rx / PCM_tx 0x9: SRC_out / SRC_in (for all the supported conversions) 0xA: Reserved 0xB: Reserved 0xC: GP_ADC / - 0xD: SD_ADC / - 0xE: Reserved 0xF: None</p> <p>Note: If any of the four available peripheral selector fields (DMA01_SEL, DMA23_SEL, DMA45_SEL, DMA67_SEL) have the same value, the lesser significant selector has higher priority and will control the DMA acknowledge signal driven to the selected peripheral. Hence, if DMA01_SEL = DMA23_SEL, the channels 0 and 1 will provide the Rx and Tx DMA acknowledge signals for the selected peripheral. Consequently, it is suggested to assign the intended peripheral value to a unique selector field.</p>	0xF

Table 878: DMA_INT_STATUS_REG (0x50040904)

Bit	Mode	Symbol	Description	Reset
15	R	DMA_BUS_ERR7	<p>0 = No bus error response is detected for channel 7 1 = Bus error response detected for channel 7</p> <p>NOTE: This bit-field is auto-clear and it is initialized to '0' as soon as a new transfer is started. It is also noted that when the specific channel becomes secure (so when either of the PROT_AES_KEY_READ and PROT_QSPI_KEY_READ bits of SECURE_BOOT_REG is set), this bit-field is overruled to '0', masking the bus error status reporting to the user.</p>	0x0
14	R	DMA_BUS_ERR6	<p>0 = No bus error response is detected for channel 6 1 = Bus error response detected for channel 6</p> <p>NOTE: This bit-field is auto-clear and it is initialized to '0' as soon as a new transfer is started.</p>	0x0
13	R	DMA_BUS_ERR5	<p>0 = No bus error response is detected for channel 5 1 = Bus error response detected for channel 5</p>	0x0

Bit	Mode	Symbol	Description	Reset
			NOTE: This bit-field is auto-clear and it is initialized to '0' as soon as a new transfer is started.	
12	R	DMA_BUS_ERR4	0 = No bus error response is detected for channel 4 1 = Bus error response detected for channel 4 NOTE: This bit-field is auto-clear and it is initialized to '0' as soon as a new transfer is started.	0x0
11	R	DMA_BUS_ERR3	0 = No bus error response is detected for channel 3 1 = Bus error response detected for channel 3 NOTE: This bit-field is auto-clear and it is initialized to '0' as soon as a new transfer is started.	0x0
10	R	DMA_BUS_ERR2	0 = No bus error response is detected for channel 2 1 = Bus error response detected for channel 2 NOTE: This bit-field is auto-clear and it is initialized to '0' as soon as a new transfer is started.	0x0
9	R	DMA_BUS_ERR1	0 = No bus error response is detected for channel 1 1 = Bus error response detected for channel 1 NOTE: This bit-field is auto-clear and it is initialized to '0' as soon as a new transfer is started.	0x0
8	R	DMA_BUS_ERR0	0 = No bus error response is detected for channel 0 1 = Bus error response detected for channel 0 NOTE: This bit-field is auto-clear and it is initialized to '0' as soon as a new transfer is started.	0x0
7	R	DMA_IRQ_CH7	0 = IRQ on channel 7 is not set 1 = IRQ on channel 7 is set	0x0
6	R	DMA_IRQ_CH6	0 = IRQ on channel 6 is not set 1 = IRQ on channel 6 is set	0x0
5	R	DMA_IRQ_CH5	0 = IRQ on channel 5 is not set 1 = IRQ on channel 5 is set	0x0
4	R	DMA_IRQ_CH4	0 = IRQ on channel 4 is not set 1 = IRQ on channel 4 is set	0x0
3	R	DMA_IRQ_CH3	0 = IRQ on channel 3 is not set 1 = IRQ on channel 3 is set	0x0
2	R	DMA_IRQ_CH2	0 = IRQ on channel 2 is not set 1 = IRQ on channel 2 is set	0x0
1	R	DMA_IRQ_CH1	0 = IRQ on channel 1 is not set 1 = IRQ on channel 1 is set	0x0
0	R	DMA_IRQ_CH0	0 = IRQ on channel 0 is not set 1 = IRQ on channel 0 is set	0x0

Table 879: DMA_CLEAR_INT_REG (0x50040908)

Bit	Mode	Symbol	Description	Reset
7	R0/W	DMA_RST_IRQ_CH7	Writing a 1 will reset the status bit of DMA_INT_STATUS_REG for channel 7 ; writing a 0 will have no effect	0x0

Bit	Mode	Symbol	Description	Reset
6	R0/W	DMA_RST_IRQ_CH6	Writing a 1 will reset the status bit of DMA_INT_STATUS_REG for channel 6 ; writing a 0 will have no effect	0x0
5	R0/W	DMA_RST_IRQ_CH5	Writing a 1 will reset the status bit of DMA_INT_STATUS_REG for channel 5 ; writing a 0 will have no effect	0x0
4	R0/W	DMA_RST_IRQ_CH4	Writing a 1 will reset the status bit of DMA_INT_STATUS_REG for channel 4 ; writing a 0 will have no effect	0x0
3	R0/W	DMA_RST_IRQ_CH3	Writing a 1 will reset the status bit of DMA_INT_STATUS_REG for channel 3 ; writing a 0 will have no effect	0x0
2	R0/W	DMA_RST_IRQ_CH2	Writing a 1 will reset the status bit of DMA_INT_STATUS_REG for channel 2 ; writing a 0 will have no effect	0x0
1	R0/W	DMA_RST_IRQ_CH1	Writing a 1 will reset the status bit of DMA_INT_STATUS_REG for channel 1 ; writing a 0 will have no effect	0x0
0	R0/W	DMA_RST_IRQ_CH0	Writing a 1 will reset the status bit of DMA_INT_STATUS_REG for channel 0 ; writing a 0 will have no effect	0x0

Table 880: DMA_INT_MASK_REG (0x5004090C)

Bit	Mode	Symbol	Description	Reset
7	R/W	DMA_IRQ_ENABLE7	0 = disable interrupts on channel 7 1 = enable interrupts on channel 7	0x0
6	R/W	DMA_IRQ_ENABLE6	0 = disable interrupts on channel 6 1 = enable interrupts on channel 6	0x0
5	R/W	DMA_IRQ_ENABLE5	0 = disable interrupts on channel 5 1 = enable interrupts on channel 5	0x0
4	R/W	DMA_IRQ_ENABLE4	0 = disable interrupts on channel 4 1 = enable interrupts on channel 4	0x0
3	R/W	DMA_IRQ_ENABLE3	0 = disable interrupts on channel 3 1 = enable interrupts on channel 3	0x0
2	R/W	DMA_IRQ_ENABLE2	0 = disable interrupts on channel 2 1 = enable interrupts on channel 2	0x0
1	R/W	DMA_IRQ_ENABLE1	0 = disable interrupts on channel 1 1 = enable interrupts on channel 1	0x0
0	R/W	DMA_IRQ_ENABLE0	0 = disable interrupts on channel 0 1 = enable interrupts on channel 0	0x0

42.28 Charger Registers

Table 881: Register map CHARGER

Address	Register	Description
0x50040400	CHARGER_CTRL_REG	Charger main control register
0x50040404	CHARGER_TEST_CTRL_REG	Charger test control register
0x50040408	CHARGER_STATUS_REG	Charger main status register
0x5004040C	CHARGER_VOLTAGE_PARAM_REG	Charger voltage settings register
0x50040410	CHARGER_CURRENT_PARAM_REG	Charger current settings register
0x50040414	CHARGER_TEMPSET_PARAM_REG	Charger battery temperature settings register
0x50040418	CHARGER_PRE_CHARGE_TIMER_REG	Maximum pre-charge time limit register
0x5004041C	CHARGER_CC_CHARGE_TIMER_REG	Maximum CC-charge time limit register
0x50040420	CHARGER_CV_CHARGE_TIMER_REG	Maximum CV-charge time limit register
0x50040424	CHARGER_TOTAL_CHARGE_TIMER_REG	Maximum total charge time limit register
0x50040428	CHARGER_JEITA_V_CHARGE_REG	JEITA-compliant Charge voltage settings register
0x5004042C	CHARGER_JEITA_V_PRECHARGE_REG	JEITA-compliant Pre-Charge voltage settings register
0x50040430	CHARGER_JEITA_V_REPLENISH_REG	JEITA-compliant Replenish settings register
0x50040434	CHARGER_JEITA_V_OVP_REG	JEITA-compliant OVP settings register
0x50040438	CHARGER_JEITA_CURRENT_REG	JEITA-compliant current settings register
0x5004043C	CHARGER_VBAT_COMP_TIMER_REG	Main Vbat comparator timer register
0x50040440	CHARGER_VOVP_COMP_TIMER_REG	Vbat OVP comparator timer register
0x50040444	CHARGER_TDIE_COMP_TIMER_REG	Die temperature comparator timer register
0x50040448	CHARGER_TBAT_MON_TIMER_REG	Battery temperature monitor interval timer
0x5004044C	CHARGER_TBAT_COMP_TIMER_REG	Battery temperature (main) comparator timer
0x50040450	CHARGER_THOT_COMP_TIMER_REG	Battery temperature comparator timer for "Hot" zone
0x50040454	CHARGER_PWR_UP_TIMER_REG	Charger power-up (settling) timer
0x50040458	CHARGER_STATE_IRQ_MASK_REG	Mask register of Charger FSM IRQs
0x5004045C	CHARGER_ERROR_IRQ_MASK_REG	Mask register of Charger Error IRQs

Address	Register	Description
0x50040460	CHARGER_STATE_IRQ_STATUS_REG	Status register of Charger FSM IRQs
0x50040464	CHARGER_ERROR_IRQ_STATUS_REG	Status register of Charger Error IRQs
0x50040468	CHARGER_STATE_IRQ_CLR_REG	Interrupt clear register of Charger FSM IRQs
0x5004046C	CHARGER_ERROR_IRQ_CLR_REG	Interrupt clear register of Charger Error IRQs

Table 882: CHARGER_CTRL_REG (0x50040400)

Bit	Mode	Symbol	Description	Reset
27:22	R	EOC_INTERVAL_CHECK_TIMER	<p>The specific bit-field determines the current state of the timer used to periodically check the End-of-Charge signal, as soon as the Charger's FSM is either in CC_CHARGE or CV_CHARGE state. Thus, as soon as the Charger's FSM enters the CC_CHARGE state:</p> <ul style="list-style-type: none"> - The timer starts increasing when a positive edge detection on End-of-Charge signal occurs. - It keeps increasing until reaching the programmed EOC_INTERVAL_CHECK_THRES value, if and only if there is no detection of a negative edge on End-of-Charge signal. If this happens, the timer resets and starts over with a new End-of-Charge positive edge. - The timer also resets after having reached its programmed threshold or when the Charger's FSM next state is END_OF_CHARGE. This happens only after having found End-of-Charge signal asserted for 4 consecutive checks and provided that the specific signal has not de-asserted during the timer's interval. <p>Note: It must be noted that out of these two states, the specific timer is kept to zero. It is also noted that this timer runs at the 1Mhz clock of the Charger's block and its value always ranges from 0 to the EOC_INTERVAL_CHECK_THRES value set in the respective bit-field of CHARGER_CTRL_REG.</p>	0x0
21:16	R/W	EOC_INTERVAL_CHECK_THRES	<p>This bit-field determines the periodic interval of checking the End-of-Charge signal, when the Charger's FSM is either in CC_CHARGE or in CV_CHARGE state. To implement this, a dedicated timer has been used, counting from zero up to the value programmed into this bit-field (see also EOC_INTERVAL_CHECK_TIMER field's description).</p> <p>As soon as this timer reaches the programmed value, the End-of-Charge signal is sampled and depending on its status (high or low), another counter, keeping the number of consecutive End-of-Charge events, is increased or not. See also the description of the EOC_DEBOUNCE_CNT bit-field of CHARGER_STATUS_REG, for this counter.</p> <p>Note: The specific bit-field should always be programmed to a non-zero value.</p>	0x3F
15	R/W	REPLENISH_MODE	<p>When this bit-field is set and the Charger's FSM is in the BYPASSED state (thus, in Bypass mode), the internal multiplexer inside the digital part of the charger selects</p>	0x0

Bit	Mode	Symbol	Description	Reset
			<p>the Replenish, instead of the Pre-charge setting to be driven to the main Vbat comparator of the Charger's analogue circuitry. By this way, SW can read the respective analogue comparator's output in CHARGER_STATUS_REG (bit-field MAIN_VBAT_COMP_OUT), after the battery's voltage has reached the End-of-Charge level, and determine if the battery voltage has dropped below the Replenish level, re-starting the battery charging accordingly.</p> <p>Note: When the Charger's FSM is active and operational, this bit-field is don't care and the FSM determines which level (Pre-charge or Replenish) will be selected and driven to the analogue, depending on the current state. It is also noted that the supported Pre-charge and Replenish levels can be viewed in the respective bit-fields defined in CHARGER_VOLTAGE_PARAM_REG register.</p>	
14	R/W	PRE_CHARGE_MODE	<p>When set, this bit-field enables a signal of the same name with the bit-field, driven from the Charger's digital part towards the analogue circuitry, in order to determine the current in Pre-Charge mode. If the Charger's FSM is active and operational, the specific bit-field is don't care. Hence, it is considered only when the Charger's FSM has reached the BYPASSED state (thus, in Bypass mode).</p> <p>With the Charger's FSM being bypassed, SW should take over control and set the specific bit-field, in order to deliver the Pre-Charge instead of the normal Charge current to the Charger's analogue circuitry, during the Pre-Charge phase.</p> <p>Note: See also the description of CHARGER_CURRENT_PARAM_REG register for the Pre-Charge and normal Charge current levels supported.</p>	0x1
13	R/W	CHARGE_LOOP_HOLD	<p>When set, this bit-field disables charging, provided that the Charger's FSM has switched to the BYPASSED state. This is possible only by setting the CHARGER_BYPASS bit-field of this register.</p> <p>Thus, as soon as the Charger's FSM is bypassed, the respective signal driven by the FSM is overruled by this bit-field, making the analogue part of the Charger controllable also in this mode. If the Charger's FSM is not bypassed, this bit-field is don't care.</p>	0x1
12	R/W	JEITA_SUPPORT_DISABLED	<p>0 = Charger's JEITA FSM monitoring the battery temperature checks also if battery temperature is in the Warm or Cool zones.</p> <p>In that case, it updates accordingly all the Charger's voltage levels (Charge, Pre-Charge, Replenish and OVP) programmed in CHARGER_VOLTAGE_PARAM_REG, as well as the charge and pre-charge current settings of CHARGER_CURRENT_PARAM_REG, depending on the temperature zone determined by the analogue circuitry of the Charger (see also the JEITA registers of the Charger's register file for the Voltage/Current levels in Warm and Cool temperature zones).</p> <p>1 = Charger's JEITA FSM monitoring the battery temperature checks only if battery temperature is either</p>	0x0

Bit	Mode	Symbol	Description	Reset
			<p>in the Hot or Cold zones. In that case, it notifies the main Charger FSM to stop charging automatically, when in Hot zone. The same will happen also for the case of Cold, unless the NTC_LOW_DISABLE bit-field of CHARGER_CTRL_REG is set.</p> <p>Note : It is not recommended to have the specific bit-field kept to '0' (and thus the JEITA support enabled), if at the same time the bit-field TBAT_PROT_ENABLE of the same register is also '0'. Thus, JEITA support should be coupled with the Battery's temperature protection.</p>	
11:10	R/W	TBAT_MONITOR_MODE	<p>Battery temperature pack monitoring modes, according to the following encoding:</p> <p>00 = Battery temperature state checked and updated once, as soon as the charger is powered-up and settled.</p> <p>01 = Battery temperature state checked periodically, depending on TBAT_MON_TIMER_REG.TBAT_MON_INTERVAL and provided that Charger has been powered-up and charger's FSM is enabled.</p> <p>10 = Battery temperature state checked periodically depending on TBAT_MON_TIMER_REG.TBAT_MON_INTERVAL, provided that Charger is powered-up and regardless if the Charger's FSM is enabled or not. Hence, this mode can be effective regardless of the state of CHARGE_START bit-field of CHARGER_CTRL_REG.</p> <p>11 = When selected, it freezes the Battery temperature monitor FSM, as soon as the latter reaches the CHECK_IDLE state (see also CHARGER_STATUS_REG.CHARGER_JEITA_STATE bit-field's description for the states of this FSM). In this mode, the monitoring of Battery temperature is possible only by checking the status of TBAT_HOT_COMP_OUT and MAIN_TBAT_COMP_OUT bit-fields of CHARGER_STATUS_REG, thus by letting SW take over monitoring. This setting may be used in conjunction with Bypass mode (by setting CHARGER_BYPASS of CHARGER_CTRL_REG), so that both charging and battery temperature status monitoring are controlled by SW.</p>	0x0
9	R/W	CHARGE_TIMERS_HALT_ENABLE	<p>0 = Charge timeout timers continue running when charging is disabled because of a Die or of a Battery temperature error.</p> <p>1 = Charge timeout timers are halted in case of a Die or of a Battery temperature error.</p> <p>In that case, the global charge timer is stopped as soon as the Charger's FSM moves to TDIE_PROT or TBAT_PROT state. Also, either the Pre-Charge, the CC_CHARGE or the CV_CHARGE timer is also stopped, depending on the charging state of the FSM when the Die/Battery temperature error has been detected.</p>	0x1
8	R/W	-	Reserved	0x0
7	R/W	NTC_LOW_DISABLE	<p>0 = Charging is disabled when the battery temperature is found to have reached the "COLD" region. Therefore, the Charger's FSM moves directly to "TBAT_PROT" error and generates an IRQ to notify the system</p>	0x0

Bit	Mode	Symbol	Description	Reset
			<p>accordingly, in case the respective IRQ mask bit of CHARGER_ERROR_IRQ_MASK_REG is set. Also, CHARGER_ERROR_IRQ_STATUS_REG.</p> <p>TBAT_ERROR_IRQ field is updated accordingly.</p> <p>1 = Charging is allowed to continue, even when the battery temperature pack reaches the "COLD" region. Consequently, the FSM continues charging and no battery temperature error event is generated.</p>	
6	R/W	TBAT_PROT_ENABLE	<p>0 = Battery temperature protection disabled</p> <p>1 = Battery temperature protection enabled.</p> <p>Charging will be stopped in case Battery temperature reaches "Hot" zone. It will also be disabled when reaching "Cold" zone, provided that CHARGER_CTRL_REG.NTC_LOW_DISABLE is not set. This is handled by the Charger's FSM, which moves directly to the respective error state (TBAT_PROT), also generating an Error IRQ if the respective IRQ mask bit is set (see also CHARGER_ERROR_IRQ_MASK_REG).</p>	0x1
5	R/W	TDIE_ERROR_RESUME	<p>0 = FSM will not resume from a Die temperature error. Consequently, its state will be staying to "TDIE_PROT", for as long as this bit-field is kept low, regardless of the status of the die temperature comparator. Also, disabling the specific bit-field will reset the Die temperature error debounce counter, when the Charger's FSM is in TDIE_PROT state (so when a Die temperature error has been already detected) and the specific counter will remain frozen to 0 until the TDIE_ERROR_RESUME bit-field is set (see also the TDIE_ERROR_DEBOUNCE_CNT bit-field of CHARGER_STATUS_REG).</p> <p>1 = FSM will resume from a Die temperature error, as soon as the respective analogue comparator confirms that die temperature is again below the maximum allowed level.</p> <p>It is noted that the maximum Die temperature level is programmable via the CHARGER_TEMPSET_PARAM_REG register's respective bit-field (T_DIE_MAX).</p>	0x1
4	R/W	TDIE_PROT_ENABLE	<p>0 = Die temperature protection is disabled, thus charging will not be disabled by the Charger's FSM in case of a Die temperature error.</p> <p>1 = Die temperature protection is enabled, thus the Charger's FSM will move to "TDIE_PROT" state, disabling charging at the same time.</p> <p>It is noted that the Die temperature error event will be logged in the respective status bit of CHARGER_IRQ_ERROR_STATUS_REG and an IRQ will be generated, if and only if the corresponding mask bit of CHARGER_IRQ_MASK_REG is set.</p>	0x1
3	R/W	CHARGER_RESUME	<p>0 = Charger's FSM is not able to resume from a charge timeout error or a Vbat OVP (Over-Voltage Protection) error. Consequently, FSM stays in "ERROR" state.</p> <p>1 = Charger's FSM will resume from a charge timeout or from an OVP error, thus its state will move from "ERROR" to "DISABLED" state, so that the charge cycle starts-over.</p>	0x1

Bit	Mode	Symbol	Description	Reset
			It is noted that in the case of a Vbat OVP error, the FSM will leave "ERROR" state, as soon as the Vbat comparator for the OVP level shows that Vbat is again OK (so lower than the OVP setting).	
2	R/W	CHARGER_BYPASS	0 = Charger's FSM is active and running, notifying SW upon switching between its states 1 = Charger's FSM is bypassed, so its state stays to "BYPASS", so SW should take over the monitoring of the battery voltage and control of the charger.	0x0
1	R/W	CHARGE_START	0 = Charger's FSM is disabled, FSM stays at "DISABLED" state 1 = Charger's FSM is enabled, so FSM's state can move from DISABLED to the actual charge states, starting from "PRE_CHARGE".	0x0
0	R/W	CHARGER_ENABLE	0 = Charger's analogue circuitry is powered-down 1 = Charger's analogue circuitry is being powered-up and will be available after a certain settling time (in ms). As soon as this bit-field is set, the Charger's FSM waits for this settling time, before proceeding into DISABLED state, where it checks the Vbat level, as well as the Die temperature and the Battery temperature states. This is mandatory, before the actual charging begins, so before the FSM moves to PRE_CHARGE state. It is finally noted that the settling time is configurable via CHARGER_PWR_UP_TIMER_REG, counting with the 1Khz clock. Note: The Charger clocks must have been enabled first, by setting the CLK_SYS_REG[CLK_CHG_EN] bit-field to '1', in order to let the FSM proceed.	0x0

Table 883: CHARGER_TEST_CTRL_REG (0x50040404)

Bit	Mode	Symbol	Description	Reset
16:14	R/W	-	Reserved	0x0
13:9	R/W	-	Reserved	0xF
8:4	R/W	-	Reserved	0x8
3:0	R/W	-	Reserved	0x8

Table 884: CHARGER_STATUS_REG (0x50040408)

Bit	Mode	Symbol	Description	Reset
29:27	R	OVP_EVENTS_DEBO UNCE_CNT	The specific bit-field returns the consecutive number of times Vbat has exceeded the programmed Over-Voltage Protection (OVP) level. It is used to determine when the Charger's FSM will exit any of the charging states (PRE/CC/CV_CHARGE) and will switch to the ERROR state due to an OVP error. This will happen as soon as the respective counter of OVP events reaches or exceeds a fixed number (4), similar to the approach adopted in the End-of-Charge and Die Temperature debouncing mechanisms. The specific counter increases only while the Charger's FSM is in any of the three charging states, the Vbat OVP	0x0

Bit	Mode	Symbol	Description	Reset
			<p>interval check timer has reached the threshold set and when Vbat OVP comparator's output is asserted.</p> <p>Note 1 : By default, as soon as the counter reaches 4, the FSM will switch to the ERROR state and the counter will reset again. Thus, in that case the specific counter ranges from 0 to 4 and vice-versa. However, if the monitoring of Vbat OVP comparator's state is less frequent than 5 (4+1) times the CHARGER_OVP_COMP_TIMER_REG[OVP_INTERVAL_CHECK_THRES] and Vbat has exceeded the OVP voltage level based on the comparator's output signal, then this counter will exceed 4 and may overflow.</p> <p>This will not harm, however, the detection of the OVP event, as it only increases the number of OVP event occurrences by the debounce timer, until the OVP comparator timer's settling time has expired. Thus, the Charger FSM will again switch to ERROR when the counter has reached or exceeded 4 (bit [2] of OVP_EVENTS_DEBOUNCE_CNT is set) and the OVP comparator's timer has expired.</p> <p>Note 2: See also the OVP_INTERVAL_CHECK_TIMER, OVP_INTERVAL_CHECK_THRES of CHARGER_OVP_COMP_TIMER_REG, for the debouncing mechanism of the Vbat OVP comparator's output.</p>	
26:24	R	EOC_EVENTS_DEBOUNCE_CNT	<p>The specific bit-field returns the number of times the End-of-Charge signal has been consecutively found to be high. It is used to determine when the Charger's FSM will switch from CV_CHARGE to END_OF_CHARGE state, implementing a debounce mechanism on End-of-Charge signal, coming from the analogue circuitry of the Charger towards the FSM.</p> <p>The specific counter, running with the Charger's 1Mhz clock:</p> <ul style="list-style-type: none"> - Increases after detecting that the End-of-Charge signal is high when the respective interval for the End-of-Charge check expires. This actually happens after having detected a positive edge on End-of-Charge signal, since only after that is it possible for the interval timer to start ticking. - Resets to zero when End-of-Charge is seen low when the interval timer has expired or when an End-of-Charge negative edge is seen before the timer's expiration, starting-over. - Does not count if End-of-Charge signal is seen high and either the CV_MODE signal (also driven by the analogue circuitry) or the End-of-Charge signal of the previous clock cycle is seen low. - Is reset when the Charger's FSM is not in either the CC_CHARGE or the CV_CHARGE state or after having reached "100"(4). This is the threshold after which the End-of-Charge signal is considered stable by the Charger's FSM, to switch to the END_OF_CHARGE state. Thus, in practice, the specific counter (and bit-field) ranges between 0 and 4. <p>Note: See also the EOC_INTERVAL_CHECK_TIMER/THRES bit-fields of CHARGER_CTRL_REG.</p>	0x0

Bit	Mode	Symbol	Description	Reset
23:21	R	TDIE_ERROR_DEBOUNCE_CNT	<p>The specific bit-field returns the consecutive number of times the Die temperature is seen either above (for the case of an error) or below (for the case of recovering from an error) the set Die temperature level. This is performed by a counter, which is increased:</p> <ul style="list-style-type: none"> - Each time the Die temperature comparator shows that Die temperature exceeds the set level, and while charging is active, provided that Die temperature protection is enabled. If, however, the CHARGER_CTRL_REG.TDIE_PROT_ENABLE bit-field is not set, the counter is reset and stays frozen to zero. - Each time the Die temperature comparator shows that Die temperature is again below the set level, and while the FSM is in the Die temperature protection error state (TDIE_PROT) and the TDIE_ERROR_RESUME bit-field of CHARGER_CTRL_REG is set. If the specific bit-field is not set, the debounce counter is reset to 0 and it is kept frozen until the FSM is again enabled to resume from Die temperature errors. <p>If the Die temperature comparator of the Charger's analogue circuitry shows that temperature has exceeded the programmed level for four consecutive times and charging is active, the Charger's FSM considers this as a Die temperature error and moves to the TDIE_PROT state, resetting the timer at the same time and of course halting charging.</p> <p>To recover from this state and resume charging, the FSM needs to see that Die temperature is below the programmed level for four consecutive times, again, provided that the TDIE_ERROR_RESUME bit-field of CHARGER_CTRL_REG is set. As soon as this happens, the error counter is again reset and the Charger's FSM resumes, by moving to PRE_CHARGE state. Consequently, the counter's value always ranges from 0 to 4.</p> <p>Note: When the Charger's FSM is in BYPASSED state, then this bit-field is reset and kept frozen to zero. Consequently, the number of times Die temperature has exceeded the pre-programmed threshold should be determined by SW.</p>	0x0
20:18	R	CHARGER_JEITA_STATE	<p>Returns the state of the Charger's JEITA FSM. This FSM is used to update the state of the battery temperature pack, depending on the value programmed in CHARGER_CTRL_REG.TBAT_MONITOR_MODE bit-field. The encoding of the states is as follows:</p> <ul style="list-style-type: none"> 0x0 = CHECK_IDLE 0x1 = CHECK_THOT 0x2 = CHECK_TCOLD 0x3 = CHECK_TWARM 0x4 = CHECK_TCOOL 0x5 = CHECK_TNORMAL 0x6 = UPDATE_TBAT <p>The FSM initially is in CHECK_IDLE state and starts checking the battery's temperature by visiting the states that check for the respective temperature area (Hot, Cold, Warm, Cool, Normal), in this order.</p>	0x0

Bit	Mode	Symbol	Description	Reset
			If the battery temperature is found to be in one of the aforementioned zones, it directly moves to UPDATE_TBAT state, to update the battery temperature's state and notify the main FSM of the Charger about the battery temperature status, before returning to the CHECK_IDLE state. A Charger State IRQ will also be generated upon refreshing the battery temperature status (see also the description of CHARGER_STATE_IRQ_MASK_REG register).	
17:14	R	CHARGER_STATE	<p>Indicating the state of the Charger's main FSM, based on the following encoding:</p> <p>0x0 = POWER_UP (Charger's power-up not yet set) 0x1 = INIT (Charger is being power-up, FSM waiting for the analogue to settle) 0x2 = DISABLED (Charger powered-up but charging not yet started) 0x3 = PRE_CHARGE (Pre-Charge state) 0x4 = CC_CHARGE (Constant Current state) 0x5 = CV_CHARGE (Constant Voltage state) 0x6 = END_OF_CHARGE (End-of-Charge state) 0x7 = TDIE_PROT (Die temperature protection state, visited when Die temperature limit is exceeded) 0x8 = TBAT_PROT (Battery temperature protection state, visited when Battery temperature is either COLD or HOT) 0x9 = BYPASSED (Bypassed state, visited only when the FSM is bypassed and SW takes over control) 0xA = ERROR (Error state, visited when a charge time-out occurs or in the case of Vbat exceeding over-voltage level)</p>	0x0
13:9	R	TBAT_STATUS	<p>Battery pack temperature status, according to the following ("1-Hot"-like) encoding:</p> <p>0x1 : Battery temperature in COLD zone (default) 0x2 : Battery temperature in COOL zone 0x4 : Battery temperature in NORMAL zone (above COOL and below WARM zones) 0x8 : Battery temperature in WARM zone 0x10 : Battery temperature in HOT zone</p> <p>It is noted that, according to the JEITA standard (supported if the JEITA_SUPPORT_DISABLED bit-field of CHARGER_CTRL_REG is not set), if the battery pack temperature is in the "HOT" zone, charging will always be stopped. The same will happen also for the case of the COLD zone, unless the "NTC_LOW_DISABLE" bit-field of CHARGER_CTRL_REG is set. In that case, charging will be continued.</p> <p>It is finally noted that only the aforementioned values are available for this bit-field, since it is 1-Hot encoding based. Not more than 1 bit can be high at the same time, since this would mean that battery temperature is at two different temperature zones concurrently.</p>	0x1
8	R	MAIN_TBAT_COMP_OUT	Returns the status of the main battery temperature comparator. This comparator by default checks if the battery temperature is in the Cold zone. However, if JEITA support is enabled and battery temperature is	0x0

Bit	Mode	Symbol	Description	Reset
			<p>found to not be in either the Hot or the Cold zone, the same comparator is used to check for the Warm and Cool zones, as JEITA suggests.</p> <p>The specific bit-field is suggested to be used in bypass mode and when the JEITA support is disabled (so when the battery temperature is checked against the Hot and the Cold zones). In that case, the comparator checks the battery temperature against the Cold level and its status can be as follows:</p> <p>0 = Battery temperature pack is found to be below the Cold level, so in the non-allowed Cold temperature zone. Thus, charging will be disabled, provided that the NTC_LOW_DISABLE bit-field of CHARGER_CTRL_REG is not set.</p> <p>1 = Battery temperature pack is found to be above the non-allowed Cold temperature zone. Thus, charging will be continued, provided that battery temperature will not be in the Hot zone as well.</p> <p>When the Charger's main FSM is active and JEITA is enabled, the Charger's digital block takes over and controls the respective comparator's output.</p>	
7	R	TBAT_HOT_COMP_OUT	<p>Returns the status of the battery temperature comparator dedicated to the Hot temperature zone.</p> <p>0 = Battery temperature pack is found to be below the Hot zone</p> <p>1 = Battery temperature pack is found to be in the non-allowed Hot temperature zone. Thus, charging will be disabled, provided that battery temperature protection is enabled.</p>	0x0
6	R	TDIE_COMP_OUT	<p>0 = Die temperature is found to be below the programmed level, set in CHARGER_TEMPSET_PARAM_REG.TDIE_SET level (normal operation)</p> <p>1 = Die temperature is found to be above the set level.</p> <p>Charging will be disabled if Die temperature protection is enabled and the Die temperature is found to be above the set level four consecutive times (see also TDIE_ERROR_DEBOUNCE_CNT bit-field). In that case, the Charger's FSM will also move the respective error state (TDIE_PROT) and an IRQ may be generated, if the respective mask bit of CHARGER_ERROR_IRQ_MASK_REG is set.</p>	0x0
5	R	VBAT_OVP_COMP_OUT	<p>0 = Vbat has not exceeded the Over-Voltage Protection (OVP) voltage limit, according to the respective analogue comparator's output.</p> <p>1 = Vbat is found to have exceeded the OVP voltage setting, thus charging should be disabled.</p> <p>The OVP voltage settings are defined in CHARGER_VOLTAGE_PARAM_REG.V_OVP (for the Normal battery temperature zone), as well as in CHARGER_JEITA_V_OVP_REG (for Cool and Warm temperature zones, to comply with JEITA).</p>	0x0
4	R	MAIN_VBAT_COMP_OUT	<p>This bit-field reflects the status of the main Vbat comparator residing in the analogue circuitry of the Charger.</p>	0x0

Bit	Mode	Symbol	Description	Reset
			<p>This comparator is used to check Vbat against either the Pre-Charge or the Replenish voltage level, depending on what is driven by the Charger's digital block.</p> <p>Thus, when the FSM is active, the comparator gets as reference the Replenish setting as soon as the FSM has reached the END_OF_CHARGE state. Otherwise, the Pre-Charge voltage setting is driven, including the Bypass mode.</p> <p>According to the above, the encoding is as follows for the case the comparator compares Vbat against the Pre-Charge level:</p> <p>0 = Vbat has not exceeded the set Pre-Charge voltage level.</p> <p>1 = Vbat has reached or exceeded the set Pre-Charge voltage level.</p> <p>For the case the comparator compares against the Replenish level (when the FSM has reached the END_OF_CHARGE state, so when the charging has been completed), the encoding is as follows:</p> <p>0 = Vbat has dropped below the set Replenish level, so charging will re-start and the FSM will move to the PRE_CHARGE state.</p> <p>1 = Vbat is still greater or equal to the set Replenish level, thus charging remains in hold and the FSM in END_OF_CHARGE state.</p>	
3	R	END_OF_CHARGE	<p>0 = Actual charge current is above the current level programmed in I_END_OF_CHARGE field of CHARGER_CURRENT_PARAM_REG (or charger is off)</p> <p>1 = Actual charge current is below the current level programmed in I_END_OF_CHARGE bit-field of CHARGER_CURRENT_PARAM_REG.</p>	0x0
2	R	CHARGER_CV_MODE	<p>0 = Charger's voltage loop not in regulation (or Charger is off)</p> <p>1 = Charger's Constant Voltage (CV) mode active, voltage loop in regulation</p>	0x0
1	R	CHARGER_CC_MODE	<p>0 = Charger's Current loop not in regulation (or Charger is off)</p> <p>1 = Charger's Constant Current (CC) mode active, current loop in regulation</p>	0x0
0	R	CHARGER_IS_POWERED_UP	<p>0 = Charger is either off or it is being powered-on but the analogue circuitry is not yet settled. The charger's main FSM is either in POWER_UP or INIT states.</p> <p>1 = Charger is powered-up, so its analogue circuitry should now be settled. The Charger's FSM has left both power-up states (POWER_UP, INIT), so charging can start.</p>	0x0

Table 885: CHARGER_VOLTAGE_PARAM_REG (0x5004040C)

Bit	Mode	Symbol	Description	Reset
23:18	R/W	V_OVP	This bit-field determines the VBAT Over-voltage protection limit. This Over-voltage protection level is used by the Charger's analogue circuitry and specifically	0x32

Bit	Mode	Symbol	Description	Reset
			<p>by a dedicated comparator, the output of which is sampled by the digital block of the Charger. As soon as VBAT is detected to have reached or exceeded this level, the Charger's FSM moves to ERROR state, interrupting charging. If the respective Error IRQ mask bit is set, an Error IRQ pulse will be also generated.</p> <p>Regarding the actual range of supported values for this bit-field, see the the description of V_CHARGE bit-field of this register.</p>	
17:12	R/W	V_REPLENISH	<p>This bit-field determines the absolute value (in V) of the Replenish voltage threshold. As soon as charging has been completed and the Charger's FSM has reached the END_OF_CHARGE state, the respective analogue comparator of the Charger compares VBAT with the Replenish level. If VBAT is found to have dropped below this level, charging should start-over again and in that case, the FSM moves again to the PRE_CHARGE state.</p> <p>Regarding the supported Replenish voltage levels, see the description of V_CHARGE bit-field.</p>	0x21
11:6	R/W	V_PRECHARGE	<p>This bit-field determines the voltage level at which the battery is considered as Pre-charged and therefore the Charger's FSM should move to the CC_CHARGE state, entering the Constant Current charging phase.</p> <p>Regarding the supported Pre-Charge voltage levels, see also the description of V_CHARGE bit-field of this register.</p>	0x8
5:0	R/W	V_CHARGE	<p>This bit-field determines the charge voltage levels supported. The supported levels are determined according to the following encoding:</p> <ul style="list-style-type: none"> 0 : 2.80V 1 : 2.85V 2 : 2.90V 3 : 2.95V 4 : 3.00V 5 : 3.05V 6 : 3.10V 7 : 3.15V 8 : 3.20V 9 : 3.25V 10 : 3.30V 11 : 3.35V 12 : 3.40V 13 : 3.45V 14 : 3.50V 15 : 3.55V 16 : 3.60V 17 : 3.65V 18 : 3.70V 19 : 3.75V 20 : 3.80V 21 : 3.82V 22 : 3.84V 	0x2B

Bit	Mode	Symbol	Description	Reset
			23 : 3.86V	
			24 : 3.88V	
			25 : 3.90V	
			26 : 3.92V	
			27 : 3.94V	
			28 : 3.96V	
			29 : 3.98V	
			30 : 4.00V	
			31 : 4.02V	
			32 : 4.04V	
			33 : 4.06V	
			34 : 4.08V	
			35 : 4.10V	
			36 : 4.12V	
			37 : 4.14V	
			38 : 4.16V	
			39 : 4.18V	
			40 : 4.20V	
			41 : 4.22V	
			42 : 4.24V	
			43 : 4.26V	
			44 : 4.28V	
			45 : 4.30V	
			46 : 4.32V	
			47 : 4.34V	
			48 : 4.36V	
			49 : 4.38V	
			50 : 4.40V	
			51 : 4.42V	
			52 : 4.44V	
			53 : 4.46V	
			54 : 4.48V	
			55 : 4.50V	
			56 : 4.52V	
			57 : 4.54V	
			58 : 4.56V	
			59 : 4.58V	
			60 : 4.60V	
			61 : 4.70V	
			62 : 4.80V	
			63 : 4.90V*	
			It has to be noted that the specific values correspond to the normal battery temperature zone. However, the specific register field may be updated by the JEITA FSM (which checks the battery temperature either once or periodically), in order to adapt the charge voltage to the battery temperature zone (see also CHARGER_CTRL_REG.TBAT_MONITOR_MODE field as well). This is valid also for the other three fields of the current register. Consequently, in that case the register	

Bit	Mode	Symbol	Description	Reset
			<p>returns the Charge voltage settings that abide to the JEITA requirements for the battery (either COOL, WARM or NORMAL).</p> <p>Note: Option "63" (4.90V) is not supported for V_CHARGE, V_PRECHARGE and V_REPLENISH bit-fields (and respective levels). It should be used only in the V_OVP bit-field, as the (maximum) Over-voltage protection level.</p>	

Table 886: CHARGER_CURRENT_PARAM_REG (0x50040410)

Bit	Mode	Symbol	Description	Reset
15	R/W	I_EOC_DOUBLE_RANGE	When set, the specific bit-field enables an increase of the (%) range of End-of-Charge current setting. Consequently, the default lower and upper limits of 4% of I_CHARGE (value 0x0 of I_END_OF_CHARGE bit-field) and 16% (value 0x7 of the same bit-field) are increased to 8.8% and 35.2% respectively, as soon as the I_EOC_DOUBLE_RANGE field is set.	0x0
14:12	R/W	I_END_OF_CHARGE	<p>End-of-Charge current setting, ranging from 4%("000") to 16% ("111") of the charge current set, with a step size of 1.5% for the first 4 settings and 2% for the last 4 settings, as follows (when I_EOC_DOUBLE_RANGE = 0):</p> <p>000 : 4%</p> <p>001 : 5.5%</p> <p>010 : 7%</p> <p>011 : 8.5%</p> <p>100 : 10%</p> <p>101 : 12%</p> <p>110 : 14%</p> <p>111 : 16%</p> <p>When I_EOC_DOUBLE_RANGE = 1, the range is:</p> <p>000 : 8.8%</p> <p>001 : 12.1%</p> <p>010 : 15.4%</p> <p>011 : 18.7%</p> <p>100 : 22%</p> <p>101 : 26.4%</p> <p>110 : 30.8%</p> <p>111 : 35.2%</p>	0x2
11:6	R/W	I_PRECHARGE	<p>This bit-field determines the Pre-Charge current, in mA, ranging from 0.5 to 56mA, according to the following encoding:</p> <p>0 : 0.5 mA</p> <p>1 : 1 mA</p> <p>2 : 1.5mA</p> <p>3 : 2 mA</p> <p>4 : 2.5mA</p> <p>5 : 3 mA</p> <p>6 : 3.5mA</p>	0x3

Bit	Mode	Symbol	Description	Reset
			7 : 4 mA	
			8 : 4.5mA	
			9 : 5 mA	
			10 : 5.5mA	
			11 : 6 mA	
			12 : 6.5mA	
			13 : 7 mA	
			14 : 7.5mA	
			15 : 8 mA	
			16 : 9 mA	
			17 : 10 mA	
			18 : 11 mA	
			19 : 12 mA	
			20 : 13 mA	
			21 : 14 mA	
			22 : 15 mA	
			23 : 16 mA	
			24 : 17 mA	
			25 : 18 mA	
			26 : 19 mA	
			27 : 20 mA	
			28 : 21 mA	
			29 : 22 mA	
			30 : 23 mA	
			31 : 24 mA	
			32 : 26 mA	
			33 : 28 mA	
			34 : 30 mA	
			35 : 32 mA	
			36 : 34 mA	
			37 : 36 mA	
			38 : 38 mA	
			39 : 40 mA	
			40 : 42 mA	
			41 : 44 mA	
			42 : 46 mA	
			43 : 48 mA	
			44 : 50 mA	
			45 : 52 mA	
			46 : 54 mA	
			47 : 56 mA	
			48 : 56 mA	
			49 : 56 mA	
			50 : 56 mA	
			51 : 56 mA	
			52 : 56 mA	
			53 : 56 mA	
			54 : 56 mA	

Bit	Mode	Symbol	Description	Reset
			55 : 56 mA 56 : 56 mA 57 : 56 mA 58 : 56 mA 59 : 56 mA 60 : 56 mA 61 : 56 mA 62 : 56 mA 63 : 56 mA	
5:0	R/W	I_CHARGE	This bit-field determines the charge current range, in mA. The range is from 5mA to 560mA, according to the following encoding: 0 : 5 mA 1 : 10 mA 2 : 15 mA 3 : 20 mA 4 : 25 mA 5 : 30 mA 6 : 35 mA 7 : 40 mA 8 : 45 mA 9 : 50 mA 10 : 55 mA 11 : 60 mA 12 : 65 mA 13 : 70 mA 14 : 75 mA 15 : 80 mA 16 : 90 mA 17 : 100 mA 18 : 110 mA 19 : 120 mA 20 : 130 mA 21 : 140 mA 22 : 150 mA 23 : 160 mA 24 : 170 mA 25 : 180 mA 26 : 190 mA 27 : 200 mA 28 : 210 mA 29 : 220 mA 30 : 230 mA 31 : 240 mA 32 : 260 mA 33 : 280 mA 34 : 300 mA 35 : 320 mA	0x6

Bit	Mode	Symbol	Description	Reset
			36 : 340 mA 37 : 360 mA 38 : 380 mA 39 : 400 mA 40 : 420 mA 41 : 440 mA 42 : 460 mA 43 : 480 mA 44 : 500 mA 45 : 520 mA 46 : 540 mA 47 : 560 mA 48 : 560 mA 49 : 560 mA 50 : 560 mA 51 : 560 mA 52 : 560 mA 53 : 560 mA 54 : 560 mA 55 : 560 mA 56 : 560 mA 57 : 560 mA 58 : 560 mA 59 : 560 mA 60 : 560 mA 61 : 560 mA 62 : 560 mA 63 : 560 mA Note: It has to be noted that the specific values correspond to the normal battery temperature zone. However, the specific register field may be updated by the JEITA FSM (which checks the battery temperature either once or periodically), in order to adapt the Charge current to the new battery temperature zone (see also CHARGER_CTRL_REG.TBAT_MONITOR_MODE field as well). This is valid also for the Pre-Charge current field of this register and provided that JEITA support is enabled in CHARGER_CTRL_REG. Consequently, in that case the register return the Charge current settings that abide to the JEITA requirements for the battery (either COOL, WARM or NORMAL).	

Table 887: CHARGER_TEMPSET_PARAM_REG (0x50040414)

Bit	Mode	Symbol	Description	Reset
26:24	R/W	TDIE_MAX	This bit-field determines the maximum Die temperature level limit, ranging from 0C to 130C, according to the following encoding: 000: 0 C (mainly for test purposes) 001: 50 C	0x3

Multi-Core Bluetooth 5.2 SoC Family with System PMU

Bit	Mode	Symbol	Description	Reset
			010: 80 C 011: 90 C 100: 100 C 101: 110 C 110: 120 C 111: 130 C	
23:18	R/W	TBAT_HOT	This bit-field determines the battery temperature above which the charge current is zero, defining the "Hot" battery temperature zone. It ranges from minus 10C to 53C. The range is the same with the one defined in detail in TBAT_COLD bit-field.	0x37
17:12	R/W	TBAT_WARM	This bit-field determines the battery temperature above which the charge current is reduced, defining the "Warm" temperature zone. It ranges from minus 10C to 53C. The range is the same with the one defined in detail in TBAT_COLD bit-field.	0x2D
11:6	R/W	TBAT_COOL	This bit-field determines the battery temperature below which the charge current is reduced, defining the "Cool" temperature zone. It ranges from minus 10C to 53C and the range is the same with the one defined in TBAT_COLD bit-field.	0x14
5:0	R/W	TBAT_COLD	This bit-field determines the battery temperature below which the charge current is zero, defining the "Cold" temperature zone. It ranges from minus 10C to 53C, according to the following encoding: 0 : -10 C 1 : -9 C 2 : -8 C 3 : -7 C 4 : -6 C 5 : -5 C 6 : -4 C 7 : -3 C 8 : -2 C 9 : -1 C 10: 0 C 11: 1 C 12: 2 C 13: 3 C 14: 4 C 15: 5 C 16: 6 C 17: 7 C 18: 8 C 19: 9 C 20: 10 C 21: 11 C 22: 12 C 23: 13 C 24: 14 C 25: 15 C	0xA

Bit	Mode	Symbol	Description	Reset
			26 : 16 C	
			27 : 17 C	
			28 : 18 C	
			29 : 19 C	
			30 : 20 C	
			31 : 21 C	
			32 : 22 C	
			33 : 23 C	
			34 : 24 C	
			35 : 25 C	
			36 : 26 C	
			37 : 27 C	
			38 : 28 C	
			39 : 29 C	
			40 : 30 C	
			41 : 31 C	
			42 : 32 C	
			43 : 33 C	
			44 : 34 C	
			45 : 35 C	
			46 : 36 C	
			47 : 37 C	
			48 : 38 C	
			49 : 39 C	
			50 : 40 C	
			51 : 41 C	
			52 : 42 C	
			53 : 43 C	
			54 : 44 C	
			55 : 45 C	
			56 : 46 C	
			57 : 47 C	
			58 : 48 C	
			59 : 49 C	
			60 : 50 C	
			61 : 51 C	
			62 : 52 C	
			63 : 53 C	

Table 888: CHARGER_PRE_CHARGE_TIMER_REG (0x50040418)

Bit	Mode	Symbol	Description	Reset
30:16	R	PRE_CHARGE_TIMER	Returns the current value of the Pre-Charge timeout counter, running at a 1Hz clock. The range of the specific timer is identical to the one of the CC-Charge and the CV-Charge timers, so it may count up to 6 hours, ranging from 0 to MAX_PRE_CHARGE_TIMER. It is reset to 0 when the Charger's FSM is either in DISABLED or in END_OF_CHARGE state.	0x0

Bit	Mode	Symbol	Description	Reset
15	R	-	Reserved	0x0
14:0	R/W	MAX_PRE_CHARGE_TIME	This bit-field determines the maximum time (measured in ticks of the Charger's 1Hz clock) allowed for the Pre-Charge stage. If this is exceeded, a Pre-Charge time-out error will be captured by the Charger's control unit and its FSM will move to the respective state (ERROR). In order to exit this state and re-start charging, the CHARGER_RESUME bit-field of CHARGER_CTRL_REG must be set. Note: The specific bit-field should be always set to a non-zero value.	0x708

Table 889: CHARGER_CC_CHARGE_TIMER_REG (0x5004041C)

Bit	Mode	Symbol	Description	Reset
30:16	R	CC_CHARGE_TIMER	Returns the current value of the CC-Charge timeout counter, running at a 1Hz clock. The range of the specific timer is identical to the one of the Pre-Charge and the CV-Charge timers, so it may count up to 6 hours, ranging from 0 to MAX_CC_CHARGE_TIME. It is reset to 0 when the Charger's FSM is either in DISABLED or in END_OF_CHARGE state.	0x0
15	R	-	Reserved	0x0
14:0	R/W	MAX_CC_CHARGE_TIME	This bit-field determines the maximum time (measured in ticks of the Charger's 1Hz clock) allowed for the CC (Constant Current) charging stage. If this is exceeded, a CC charge time-out error will be captured by the Charger's control unit and its FSM will move to the ERROR state. In order to exit this state and re-start charging, the CHARGER_RESUME bit-field of CHARGER_CTRL_REG must be set. Note: The specific bit-field should be always set to a non-zero value.	0x1C20

Table 890: CHARGER_CV_CHARGE_TIMER_REG (0x50040420)

Bit	Mode	Symbol	Description	Reset
30:16	R	CV_CHARGE_TIMER	Returns the current value of the CV-Charge timeout counter, running at a 1Hz clock. The range of the specific timer is identical to the one of the Pre-Charge and the CC-Charge timers, so it may count up to 6 hours, ranging from 0 to MAX_CV_CHARGE_TIME. It is reset to 0 when the Charger's FSM is either in DISABLED or in END_OF_CHARGE state.	0x0
15	R	-	Reserved	0x0
14:0	R/W	MAX_CV_CHARGE_TIME	This bit-field determines the maximum time (measured in ticks of the Charger's 1Hz clock) allowed for the CV (Constant Voltage) charging stage. If this is exceeded, a CV charge time-out error will be captured by the Charger's control unit and its FSM will move to the ERROR state. In order to exit this state and re-start charging, the CHARGER_RESUME bit-field of CHARGER_CTRL_REG must be set.	0x1C20

Bit	Mode	Symbol	Description	Reset
			Note: The specific bit-field should be always set to a non-zero value.	

Table 891: **CHARGER_TOTAL_CHARGE_TIMER_REG (0x50040424)**

Bit	Mode	Symbol	Description	Reset
31:16	R	TOTAL_CHARGE_TIMER	Returns the current value of the overall charge timeout counter, running at a 1Hz clock. This timer has been set to 16 bits, so that it can count up to 10.5 hours, and ranges from 0 to MAX_TOTAL_CHARGE_TIME. It is reset to 0 when the Charger's FSM is either in DISABLED or in END_OF_CHARGE state.	0x0
15:0	R/W	MAX_TOTAL_CHARGE_TIME	This bit-field determines the maximum overall charging time allowed (measured in ticks of the 1Hz clock). If this is exceeded, a total charge time-out error will be captured by the Charger's controller and its FSM will move to the ERROR state. An IRQ will be also generated if the respective IRQ mask bit of CHARGER_ERROR_IRQ_MASK_REG is already set. In order to exit this state, the "CHARGER_RESUME" bit-field of CHARGER_CTRL_REG must be set, to enable the Charger's FSM switch from ERROR to DISABLED state and start-over. Note: The specific bit-field should be always set to a non-zero value.	0x3F48

Table 892: **CHARGER_JEITA_V_CHARGE_REG (0x50040428)**

Bit	Mode	Symbol	Description	Reset
11:6	R/W	V_CHARGE_TWARM	Charge voltage setting for the Warm battery temperature zone. Regarding the range of values of this bit-field, see also the description of V_CHARGE field of CHARGER_VOLTAGE_PARAM_REG register.	0x29
5:0	R/W	V_CHARGE_TCOOL	Charge voltage setting for the Cool battery temperature zone. Regarding the range of values of this bit-field, see also the description of V_CHARGE field of CHARGER_VOLTAGE_PARAM_REG register.	0x28

Table 893: **CHARGER_JEITA_V_PRECHARGE_REG (0x5004042C)**

Bit	Mode	Symbol	Description	Reset
11:6	R/W	V_PRECHARGE_TWARM	Pre-Charge voltage setting for the Warm battery temperature zone. Regarding the range of values of this bit-field, see also the description of V_CHARGE field of CHARGER_VOLTAGE_PARAM_REG register.	0x6
5:0	R/W	V_PRECHARGE_TCOOL	Pre-Charge current setting for the Cool battery temperature zone. Regarding the range of values of this bit-field, see also the description of V_CHARGE field of CHARGER_VOLTAGE_PARAM_REG register.	0x7

Table 894: CHARGER_JEITA_V_REPLENISH_REG (0x50040430)

Bit	Mode	Symbol	Description	Reset
11:6	R/W	V_REPLENISH_TWAR M	Replenish voltage setting for the Warm battery temperature zone. Regarding the range of values of this bit-field, see also the description of V_CHARGE field of CHARGER_VOLTAGE_PARAM_REG.	0x1E
5:0	R/W	V_REPLENISH_TCOO L	Replenish voltage setting for the Cool battery temperature zone. Regarding the range of values of this bit-field, see also the description of V_CHARGE field of CHARGER_VOLTAGE_PARAM_REG.	0x1F

Table 895: CHARGER_JEITA_V_OVP_REG (0x50040434)

Bit	Mode	Symbol	Description	Reset
11:6	R/W	V_OVP_TWARM	VBAT Over-voltage Protection (OVP) setting for the Warm battery temperature zone. Regarding the range of values of this bit-field, see also the description of V_CHARGE field of CHARGER_VOLTAGE_PARAM_REG.	0x35
5:0	R/W	V_OVP_TCOOL	VBAT Over-voltage Protection (OVP) setting for the Cool battery temperature zone. Regarding the range of values of this bit-field, see also the description of V_CHARGE field of CHARGER_VOLTAGE_PARAM_REG.	0x36

Table 896: CHARGER_JEITA_CURRENT_REG (0x50040438)

Bit	Mode	Symbol	Description	Reset
23:18	R/W	I_PRECHARGE_TWA RM	Pre-Charge current setting for the Warm battery temperature zone. Regarding the range of values of this bit-field, see also the description of I_PRECHARGE field of CHARGER_CURRENT_PARAM_REG register.	0x1
17:12	R/W	I_PRECHARGE_TCO OL	Pre-Charge current setting for the Cool battery temperature zone. Regarding the range of values of this bit-field, see also the description of I_PRECHARGE field of CHARGER_CURRENT_PARAM_REG register.	0x2
11:6	R/W	I_CHARGE_TWARM	Charge current setting for the Warm battery temperature pack zone. Regarding the range of values of this bit-field, see also the description of I_CHARGE field of CHARGER_CURRENT_PARAM_REG register.	0x4
5:0	R/W	I_CHARGE_TCOOL	Charge current setting for the "COOL" battery temperature level. Regarding the range of values of this bit-field, see also the description of I_CHARGE field of CHARGER_CURRENT_PARAM_REG register.	0x5

Table 897: CHARGER_VBAT_COMP_TIMER_REG (0x5004043C)

Bit	Mode	Symbol	Description	Reset
25:16	R	VBAT_COMP_TIMER	Returns the current value of the timer used to determine when the output of the Vbat comparator (checking Vbat vs Pre_Charge and Replenish levels) must be sampled by the digital. As soon as the timer expires (down-counting to 0, starting from the value set in VBAT_COMP_SETTLING), the comparator's output is	0x0

Bit	Mode	Symbol	Description	Reset
			latched by the Charger's digital block and used by the FSM. Note: When the Charger's FSM is in BYPASSED state, this timer is kept to zero and the SW takes over. In this mode, the specific comparator checks the level of Vbat against the Pre-Charge level. Hence, SW can periodically sample the status of this comparator by reading the MAIN_VBAT_COMP_OUT bit-field of CHARGER_STATUS_REG, to determine if Vbat has exceeded the Pre-Charge level or not.	
15:10	R	-	Reserved	0x0
9:0	R/W	VBAT_COMP_SETTLING	Settling time threshold (in us) for the Vbat comparator checking Vbat vs the programmed Pre-Charge and Replenish levels. The settings (voltage levels) of the comparator are controlled by the digital block of the Charger and they are driven based on the state of the main FSM (PRE_CHARGE, END_OF_CHARGE).	0x63

Table 898: CHARGER_VOVP_COMP_TIMER_REG (0x50040440)

Bit	Mode	Symbol	Description	Reset
31:26	R	OVP_INTERVAL_CHECK_TIMER	The specific bit-field determines the current state of the timer used to periodically check the output of the Over-Voltage Protection comparator's output signal, as soon as the Charger's FSM reaches any of the charging states (PRE/CC/CV_CHARGE). When this happens, the timer starts ticking with the 1Mhz clock, ranging from 0 up to the programmed interval threshold (see also OVP_INTERVAL_CHECK_THRES field). As soon as this timer reaches the programmed threshold value, the Vbat OVP comparator's output is evaluated, increasing or not the counter keeping the consecutive OVP events. It is noted that out of the charging states, the specific timer is kept frozen to zero, not counting. Note : See also the OVP_OCCURRENCES_CNT bit-field of CHARGER_STATUS_REG for the consecutive OVP events counter.	0x0
25:16	R	VBAT_OVP_COMP_TIMER	Returns the current value of the timer used to determine when the Vbat Over-Voltage protection (OVP) comparator's output must be sampled by the digital. As soon as the timer expires (down-counting to 0, starting from VBAT_OVP_COMP_SETTLING), the comparator's output is latched by the Charger's digital block and used by the main FSM. Note: When the Charger's FSM is in BYPASSED state, this timer is kept to zero and the SW takes over, sampling the status of the VBAT_OVP_COMP_OUT bit-field of CHARGER_STATUS_REG to determine if the Vbat has exceeded the OVP limit.	0x0
15:10	R/W	OVP_INTERVAL_CHECK_THRES	This bit-field determines the periodic interval of checking the dedicated Vbat OVP comparator's output, when the Charger's FSM is in any of the charging states (PRE/CC/CV_CHARGE). The implementation is based on a dedicated timer, counting from zero up to the value programmed into this bit-field (see also	0x3F

Bit	Mode	Symbol	Description	Reset
			<p>OVP_INTERVAL_CHECK_TIMER field's description) and only when the FSM is in any of the three charging states. Out of these states, the timer is kept frozen to zero.</p> <p>As soon as this timer reaches the programmed threshold, the Vbat OVP comparator's output is sampled and depending on its level, (high or low), another counter, keeping the number of consecutive OVP events, is increased or not. The programmed threshold value should always be non-zero.</p> <p>Note: See also the OVP_DEBOUNCE_CNT bit-field of CHARGER_STATUS_REG, for the consecutive OVP events counter.</p>	
9:0	R/W	VBAT_OVP_COMP_SETTLING	Settling time threshold (in us) for the Vbat comparator checking Vbat vs the programmed Over-Voltage level.	0x63

Table 899: CHARGER_TDIE_COMP_TIMER_REG (0x50040444)

Bit	Mode	Symbol	Description	Reset
25:16	R	TDIE_COMP_TIMER	<p>Returns the current value of the timer used to determine when the Die temperature comparator's output must be sampled by the digital. As soon as the timer expires (down-counting to 0, starting from TDIE_COMP_SETTLING) the comparator's output is latched by the Charger's digital block and used by the main FSM. After expiring, the timer starts-over again, down-counting, to enable the continuous monitoring of Die temperature by the digital.</p> <p>Note: When the Charger's FSM is in BYPASSED state, this timer is kept to zero and the SW takes over, sampling the status of the TDIE_PROT_COMP_OUT bit-field of CHARGER_STATUS_REG to determine if the Die temperature limit has been exceeded.</p>	0x0
15:10	R	-	Reserved	0x0
9:0	R/W	TDIE_COMP_SETTLING	Settling time threshold (in us) for the Die temperature comparator.	0x63

Table 900: CHARGER_TBAT_MON_TIMER_REG (0x50040448)

Bit	Mode	Symbol	Description	Reset
25:16	R	TBAT_MON_TIMER	<p>This is the battery temperature monitoring timer, counting with the Charger's 1KHz clock. If the battery monitor mode is accordingly set in the TBAT_MONITOR_MODE bit-field of CHARGER_CTRL_REG (so either to 0x1 or 0x2), this timer is initially loaded with the value set in TBAT_MON_INTERVAL bit-field in the subsequent 1khz cycles starts down-counting to 0. As soon as the specific timer expires, the JEITA FSM starts-over again, to refresh the battery temperature status.</p>	0x0
15:10	R	-	Reserved	0x0
9:0	R/W	TBAT_MON_INTERVAL	Timing interval (in ms) for the Battery temperature monitoring. This interval determines how often the JEITA FSM will be checking and potentially refreshing the	0x63

Bit	Mode	Symbol	Description	Reset
			<p>Battery temperature status, by selecting accordingly the proper level (Hot, Cold, Warm, Cool or Normal), based on the feedback of the two battery temperature comparators being present in the Charger's analogue circuitry (one for the Hot level and one for Cold, Cool and Warm, to support JEITA).</p> <p>Note: The specific bit-field should be always set to a non-zero value.</p>	

Table 901: CHARGER_TBAT_COMP_TIMER_REG (0x5004044C)

Bit	Mode	Symbol	Description	Reset
25:16	R	TBAT_COMP_TIMER	Returns the main battery temperature comparator's timer, used for the latching of the comparator's output. The output of the comparator is used by the JEITA FSM, to determine the current battery temperature pack's status.	0x0
15:10	R	-	Reserved	0x0
9:0	R/W	TBAT_COMP_SETTLING	<p>Settling time (specified in us) for the main battery temperature comparator, checking for the "COOL", "COLD" and "WARM" levels. The charger's digital block uses a dedicated timer to sample the specific comparator's output. The comparator's output is latched as soon as the timer expires, reaching 0. Then, the timer is reloaded with the settling time value and starts-over, down-counting to 0.</p> <p>Note: The specific bit-field should be always set to a non-zero value.</p>	0x63

Table 902: CHARGER_THOT_COMP_TIMER_REG (0x50040450)

Bit	Mode	Symbol	Description	Reset
25:16	R	THOT_COMP_TIMER	Returns the battery temperature comparator's timer dedicated for the "Hot" level.	0x0
15:10	R	-	Reserved	0x0
9:0	R/W	THOT_COMP_SETTLING	<p>Charger's battery temperature comparator settling time (specified in us), specifically for the Hot temperature zone. The charger's digital block uses a dedicated timer to sample the specific comparator's output. The comparator's output is latched as soon as the timer expires, reaching 0. Then, the timer is reloaded with the settling time value and starts-over again</p> <p>Note: The specific bit-field should be always set to a non-zero value.</p>	0x63

Table 903: CHARGER_PWR_UP_TIMER_REG (0x50040454)

Bit	Mode	Symbol	Description	Reset
25:16	R	CHARGER_PWR_UP_TIMER	<p>Returns the current value of the charger's power-up timer, running with the 1Khz clock.</p> <p>Note: The specific timer is reset to the value programmed to CHARGER_PWR_UP_SETTLING bit-field, when the Charger's analogue circuitry has been</p>	0x0

Bit	Mode	Symbol	Description	Reset
			enabled, after being disabled initially. By setting CHARGER_CTRL_REG[CHARGER_ENABLE] to '0', the analogue part is disabled and in order to be properly enable, SW has to wait for 1ms (one 1Khz clock period) time. The latter is needed to ensure that the power-up timer's control signals in the Charger's digital part will be cleared when the analogue part is again enabled, so that a proper new start-up of the Charger's FSM is possible.	
15:10	R	-	Reserved	0x0
9:0	R/W	CHARGER_PWR_UP_SETTLING	This bit-field determines the charger's power-up (settling) time, required for the analogue circuitry of the charger. As soon as the charger is powered-on by setting the CHARGER_ENABLE bit-field of CHARGER_CTRL_REG, the charger's FSM loads a dedicated timer with this value and waits for this timer to expire, before proceeding to the next states. Note: The specific bit-field should be always set to a non-zero value.	0x63

Table 904: CHARGER_STATE_IRQ_MASK_REG (0x50040458)

Bit	Mode	Symbol	Description	Reset
11	R/W	CV_TO_PRECHARGE_IRQ_EN	When set, this bit-field enables the IRQ generation as soon as the Charger's FSM switches from CV_CHARGE to PRE_CHARGE state.	0x0
10	R/W	CC_TO_PRECHARGE_IRQ_EN	When set, this bit-field enables the IRQ generation as soon as the Charger's FSM switches from CC_CHARGE to PRE_CHARGE state.	0x0
9	R/W	CV_TO_CC_IRQ_EN	When set, this bit-field enables the IRQ generation as soon as the Charger's FSM switches from CV_CHARGE to CC_CHARGE state.	0x0
8	R/W	TBAT_STATUS_UPDATE_IRQ_EN	When set, this bit-field enables the generation of the Charger's state IRQ as soon as the battery temperature status is refreshed by the Charger's Battery temperature monitor (JEITA) FSM. As soon as the specific FSM checks the current battery temperature level, it notifies the main Charger FSM that it has run and that the Battery temperature pack state is checked (and potentially refreshed with a new status).	0x0
7	R/W	TBAT_PROT_TO_PRECHARGE_IRQ_EN	When set, this bit-field enables the Charger's state IRQ generation as soon as the Charger's FSM switches from the Battery temperature protection state (TBAT_PROT) to PRE_CHARGE, resuming charging.	0x0
6	R/W	TDIE_PROT_TO_PRECHARGE_IRQ_EN	When set, this bit-field enables the Charger's state IRQ generation as soon as the Charger's FSM switches from the Die temperature protection state (TDIE_PROT) to PRE_CHARGE, resuming charging.	0x0
5	R/W	EOC_TO_PRECHARGE_IRQ_EN	When set, this bit-field enables the Charger's State IRQ generation as soon as the Charger's FSM switches from END_OF_CHARGE again to PRE_CHARGE state. This happens when the Vbat voltage level is detected to be below the Replenish level set.	0x0

Bit	Mode	Symbol	Description	Reset
4	R/W	CV_TO_EOC_IRQ_EN	When set, this bit-field enables the IRQ generation as soon as the Charger's FSM switches from CV_CHARGE to END_OF_CHARGE state.	0x0
3	R/W	CC_TO_EOC_IRQ_EN	When set, this bit-field enables the IRQ generation as soon as the Charger's FSM switches from CC_CHARGE to END_OF_CHARGE state.	0x0
2	R/W	CC_TO_CV_IRQ_EN	When set, this bit-field enables the IRQ generation as soon as the Charger's FSM switches from CC_CHARGE to CV_CHARGE state.	0x0
1	R/W	PRECHARGE_TO_CC_IRQ_EN	When set, this bit-field enables the IRQ generation as soon as the Charger's FSM switches from PRE_CHARGE to CC_CHARGE state..	0x0
0	R/W	DISABLED_TO_PRECHARGE_IRQ_EN	When set, this bit-field enables the IRQ generation as soon as the Charger's FSM switches from DISABLED to PRE_CHARGE state.	0x0

Table 905: CHARGER_ERROR_IRQ_MASK_REG (0x5004045C)

Bit	Mode	Symbol	Description	Reset
6	R/W	TBAT_ERROR_IRQ_EN	When set, it enables the generation of Battery temperature IRQs. The IRQ is generated as soon as the JEITA FSM detects that the battery temperature is either in the "Hot" or in the "Cold" temperature region, by sampling the respective comparators' output.	0x0
5	R/W	TDIE_ERROR_IRQ_EN	When set, it enables the generation of Die temperature error IRQs. The IRQ is generated as soon as a Die temperature error is captured, so as soon as the Charger's FSM moves to the TDIE_PROT state. For this to happen, the Die temperature comparator should indicate that Die temperature has exceeded the limit defined in CHARGER_TEMPSET_PARAM_REG.TDIE_MAX.	0x0
4	R/W	VBAT_OVP_ERROR_IRQ_EN	When set, it enables the generation of VBAT_OVP IRQs. The IRQ is generated as soon as the dedicated Vbat comparator shows that Vbat has exceeded the OVP level and the Charger's FSM has switched to the respective error state ("ERROR").	0x0
3	R/W	TOTAL_CHARGE_TIMEOUT_IRQ_EN	When set, it enables the total charge timeout IRQs. The IRQ is generated as soon as the Charger's global charge timer expires, reaching 0.	0x0
2	R/W	CV_CHARGE_TIMEOUT_IRQ_EN	When set, it enables the CV charge timeout IRQs. The IRQ is generated as soon as the Charger's state timer expires, reaching 0 when the FSM is in the CV_CHARGE state.	0x0
1	R/W	CC_CHARGE_TIMEOUT_IRQ_EN	When set, it enables the CC charge timeout IRQs. The IRQ is generated as soon as the Charger's state timer, expires, reaching 0.	0x0
0	R/W	PRECHARGE_TIMEOUT_IRQ_EN	When set, it enables the Pre-Charge timeout IRQs. The IRQ is generated as soon as the Charger's state timer expires, reaching 0.	0x0

Table 906: CHARGER_STATE_IRQ_STATUS_REG (0x50040460)

Bit	Mode	Symbol	Description	Reset
11	R	CV_TO_PRECHARGE_IRQ	0 = No transition of the Charger's FSM from CV_CHARGE to PRE_CHARGE state has been captured 1 = Charger's FSM has switched from CV_CHARGE to PRE_CHARGE state	0x0
10	R	CC_TO_PRECHARGE_IRQ	0 = No transition of the Charger's FSM from CC_CHARGE to PRE_CHARGE state has been captured 1 = Charger's FSM has switched from CC_CHARGE to PRE_CHARGE state	0x0
9	R	CV_TO_CC_IRQ	0 = No transition of the Charger's FSM from CV_CHARGE to CC_CHARGE state has been captured 1 = Charger's FSM has switched from CV_CHARGE to CC_CHARGE state	0x0
8	R	TBAT_STATUS_UPDATE_IRQ	0 = No battery temperature status update event has been captured 1 = Battery temperature pack's status has been checked and refreshed by the Charger's Battery temperature monitor FSM. Thus, the new status of the battery temperature should be checked by SW.	0x0
7	R	TBAT_PROT_TO_PRECHARGE_IRQ	0 = No transition of the Charger's FSM from TBAT_PROT to PRE_CHARGE state has been captured 1 = Charger's FSM has switched from TBAT_PROT to PRE_CHARGE state, resuming charging after having recovered from a battery temperature error.	0x0
6	R	TDIE_PROT_TO_PRECHARGE_IRQ	0 = No transition of the Charger's FSM from TDIE_PROT to PRE_CHARGE state has been captured 1 = Charger's FSM has switched from TDIE_PROT to PRE_CHARGE state, resuming charging after having recovered from a Die temperature error.	0x0
5	R	EOC_TO_PRECHARGE_IRQ	0 = No transition of the Charger's FSM from END_OF_CHARGE to PRE_CHARGE state has been captured 1 = Charger's FSM has switched from END_OF_CHARGE to PRE_CHARGE state	0x0
4	R	CV_TO_EOC_IRQ	0 = No transition of the Charger's FSM from CV_CHARGE to END_OF_CHARGE state has been captured 1 = Charger's FSM has switched from CV_CHARGE to END_OF_CHARGE state	0x0
3	R	CC_TO_EOC_IRQ	0 = No transition of the Charger's FSM from CC_CHARGE to END_OF_CHARGE state has been captured 1 = Charger's FSM has switched from CC_CHARGE to END_OF_CHARGE state	0x0
2	R	CC_TO_CV_IRQ	0 = No transition of the Charger's FSM from CC_CHARGE to CV_CHARGE state has been captured 1 = Charger's FSM has switched from CC_CHARGE to CV_CHARGE state	0x0

Bit	Mode	Symbol	Description	Reset
1	R	PRECHARGE_TO_CC_IRQ	0 = No transition of the Charger's FSM from PRE_CHARGE to CC_CHARGE state has been captured 1 = Charger's FSM has switched from PRE_CHARGE to CC_CHARGE state	0x0
0	R	DISABLED_TO_PRECHARGE_IRQ	0 = No transition of the Charger's FSM from DISABLED to PRE_CHARGE state has been captured 1 = Charger's FSM has switched from DISABLED to PRE_CHARGE state	0x0

Table 907: CHARGER_ERROR_IRQ_STATUS_REG (0x50040464)

Bit	Mode	Symbol	Description	Reset
6	R	TBAT_ERROR_IRQ	0 = No Battery temperature error IRQ event is captured, so charging may continue 1 = A Battery temperature error IRQ event has been captured, declaring that the Charger's FSM has moved to the respective error state (TBAT_PROT). Note : The status bit is updated automatically when the Battery temperature is detected to be either in the HOT or in the COLD zone, regardless of the state of the respective IRQ mask bit.	0x0
5	R	TDIE_ERROR_IRQ	0 = No Die temperature error IRQ events have been captured, so charging may continue 1 = A Die temperature error IRQ event is captured, declaring that the Charger's FSM has switched to the respective error state (TDIE_PROT) and charging will be automatically stopped. Note : The status bit is updated automatically when a Die temperature error is detected, thus when the die temperature is found to have exceeded the programmed level, regardless of the state of the respective IRQ mask bit. The same applies to all the rest of the bits of CHARGER_ERROR_IRQ_STATUS_REG.	0x0
4	R	VBAT_OVP_ERROR_IRQ	0 = Vbat has not exceeded the Over-Voltage Protection (OVP) level, so charging may continue 1 = Vbat has exceeded the Over-Voltage level, thus an OVP error event has been captured. The Charger's FSM switches to the respective error state (ERROR) as soon as the OVP event is captured by the digital part of the Charger and charging will be automatically stopped.	0x0
3	R	TOTAL_CHARGE_TIME_EOUT_IRQ	0 = Total charge time counter has not yet reached the maximum charge time (set in CHARGER_TOTAL_CHARGE_TIME_REG) 1 = Total charge time counter has reached the maximum charge time programmed. The Charger's FSM will move to the respective error state (ERROR) and charging will be automatically stopped, as soon as the specific event is captured.	0x0
2	R	CV_CHARGE_TIMEOUT_IRQ	0 = State charge time counter has not yet reached the maximum CV charge time (set in CHARGER_CV_CHARGE_TIME_REG) 1 = Total charge time counter has reached the maximum CV charge time programmed. The Charger's FSM will	0x0

Bit	Mode	Symbol	Description	Reset
			move to the respective error state (ERROR) and charging will be automatically stopped, as soon as the specific event is captured.	
1	R	CC_CHARGE_TIMEO UT_IRQ	0 = State charge time counter has not yet reached the maximum CC charge time (set in CHARGER_CC_CHARGE_TIME_REG) 1 = Total charge time counter has reached the maximum CC charge time programmed. The Charger's FSM will move to the respective error state (ERROR) and charging will be automatically stopped, as soon as the specific event is captured.	0x0
0	R	PRECHARGE_TIMEO UT_IRQ	0 = State charge time counter has not yet reached the maximum Pre-charge time (set in CHARGER_PRECHARGE_TIME_REG) 1 = Total charge time counter has reached the maximum Pre-charge time programmed. The Charger's FSM will move to the respective error state (ERROR) and charging will be automatically stopped, as soon as the specific event is captured.	0x0

Table 908: CHARGER_STATE_IRQ_CLR_REG (0x50040468)

Bit	Mode	Symbol	Description	Reset
11	R0/W	CV_TO_PRECHARGE _IRQ_CLR	Writing a 1 will reset the respective Charger's State IRQ status bit ; writing a 0 will have no effect	0x0
10	R0/W	CC_TO_PRECHARGE _IRQ_CLR	Writing a 1 will reset the respective Charger's State IRQ status bit ; writing a 0 will have no effect	0x0
9	R0/W	CV_TO_CC_IRQ_CLR	Writing a 1 will reset the respective Charger's State IRQ status bit ; writing a 0 will have no effect	0x0
8	R0/W	TBAT_STATUS_UPD ATE_IRQ_CLR	Writing a 1 will reset the Battery temperature status update IRQ status bit ; writing a 0 will have no effect	0x0
7	R0/W	TBAT_PROT_TO_PR ECHARGE_IRQ_CLR	Writing a 1 will reset the respective Charger's State IRQ status bit ; writing a 0 will have no effect	0x0
6	R0/W	TDIE_PROT_TO_PRE CHARGE_IRQ_CLR	Writing a 1 will reset the respective Charger's State IRQ status bit ; writing a 0 will have no effect	0x0
5	R0/W	EOC_TO_PRECHARG E_IRQ_CLR	Writing a 1 will reset the respective Charger's State IRQ status bit ; writing a 0 will have no effect	0x0
4	R0/W	CV_TO_EOC_IRQ_CL R	Writing a 1 will reset the respective Charger's State IRQ status bit ; writing a 0 will have no effect	0x0
3	R0/W	CC_TO_EOC_IRQ_CL R	Writing a 1 will reset the respective Charger's State IRQ status bit ; writing a 0 will have no effect	0x0
2	R0/W	CC_TO_CV_IRQ_CLR	Writing a 1 will reset the respective Charger's State IRQ status bit ; writing a 0 will have no effect	0x0
1	R0/W	PRECHARGE_TO_CC _IRQ_CLR	Writing a 1 will reset the respective Charger's State IRQ status bit ; writing a 0 will have no effect	0x0
0	R0/W	DISABLED_TO_PREC HARGE_IRQ_CLR	Writing a 1 will reset the respective Charger's State IRQ status bit ; writing a 0 will have no effect	0x0

Table 909: CHARGER_ERROR_IRQ_CLR_REG (0x5004046C)

Bit	Mode	Symbol	Description	Reset
6	R0/W	TBAT_ERROR_IRQ_CLR	Writing a 1 will reset the respective Charger's Error IRQ status bit ; writing a 0 will have no effect	0x0
5	R0/W	TDIE_ERROR_IRQ_CLR	Writing a 1 will reset the respective Charger's Error IRQ status bit ; writing a 0 will have no effect	0x0
4	R0/W	VBAT_OVP_ERROR_IRQ_CLR	Writing a 1 will reset the respective Charger's Error IRQ status bit ; writing a 0 will have no effect	0x0
3	R0/W	TOTAL_CHARGE_TIMEO EOUT_IRQ_CLR	Writing a 1 will reset the respective Charger's Error IRQ status bit ; writing a 0 will have no effect	0x0
2	R0/W	CV_CHARGE_TIMEO UT_IRQ_CLR	Writing a 1 will reset the respective Charger's Error IRQ status bit ; writing a 0 will have no effect	0x0
1	R0/W	CC_CHARGE_TIMEO UT_IRQ_CLR	Writing a 1 will reset the respective Charger's Error IRQ status bit ; writing a 0 will have no effect	0x0
0	R0/W	PRECHARGE_TIMEO UT_IRQ_CLR	Writing a 1 will reset the respective Charger's Error IRQ status bit ; writing a 0 will have no effect	0x0

42.29 Clock Generation Controller Registers

Table 910: Register map CRG

Address	Register	Description
0x50000000	CLK_AMBA_REG	HCLK, PCLK, divider and clock gates
0x50000010	CLK_RADIO_REG	Radio PLL control register
0x50000014	CLK_CTRL_REG	Clock control register
0x50000018	CLK_TMR_REG	Clock control for the timers
0x5000001c	CLK_SWITCH2XTAL_REG	Switches clock from RC32M to XTAL32M
0x50000020	PMU_CTRL_REG	Power Management Unit control register
0x50000024	SYS_CTRL_REG	System Control register
0x50000028	SYS_STAT_REG	System status register
0x5000003c	CLK_RC32K_REG	32 kHz RC oscillator register
0x50000040	CLK_XTAL32K_REG	32 kHz XTAL oscillator register
0x50000044	CLK_RC32M_REG	Fast RC control register
0x50000048	CLK_RCX_REG	RCX-oscillator control register
0x5000004c	CLK_RTCDIV_REG	Divisor for RTC 100Hz clock
0x50000050	BANDGAP_REG	bandgap trimming
0x50000054	VBUS_IRQ_MASK_REG	IRQ masking
0x50000058	VBUS_IRQ_CLEAR_REG	Clear pending IRQ register
0x50000060	BOD_CTRL_REG	Brown Out Detection control register
0x50000064	BOD_LVL_CTRL0_REG	
0x50000068	BOD_LVL_CTRL1_REG	
0x5000006c	BOD_LVL_CTRL2_REG	

Multi-Core Bluetooth 5.2 SoC Family with System PMU

Address	Register	Description
0x50000070	P0_PAD_LATCH_REG	Control the state retention of the GPIO ports
0x50000074	P0_SET_PAD_LATCH_REG	Control the state retention of the GPIO ports
0x50000078	P0_RESET_PAD_LATCH_REG	Control the state retention of the GPIO ports
0x5000007c	P1_PAD_LATCH_REG	Control the state retention of the GPIO ports
0x50000080	P1_SET_PAD_LATCH_REG	Control the state retention of the GPIO ports
0x50000084	P1_RESET_PAD_LATCH_REG	Control the state retention of the GPIO ports
0x50000090	BOD_STATUS_REG	
0x50000094	POR_VBAT_CTRL_REG	Controls the POR on VBAT
0x50000098	POR_PIN_REG	Selects a GPIO pin for POR generation
0x5000009c	POR_TIMER_REG	Time for POR to happen
0x500000a0	LDO_VDDD_HIGH_CTRL_REG	LDO control register
0x500000a4	BIAS_VREF_SEL_REG	
0x500000bc	RESET_STAT_REG	Reset status register
0x500000c0	RAM_PWR_CTRL_REG	Control power state of System RAMS
0x500000cc	SECURE_BOOT_REG	Controls secure booting
0x500000d4	DISCHARGE_RAIL_REG	Immediate rail resetting. There is no LDO/DCDC gating
0x500000ec	ANA_STATUS_REG	Analog Signals Status Register
0x500000f0	POWER_CTRL_REG	Power control register
0x500000f4	PMU_SLEEP_REG	Configures the sleep/wakeup strategy
0x500000f8	PMU_TRIM_REG	LDO trimming register
0x50010000	CLK_FREQ_TRIM_REG	Xtal frequency trimming register.
0x50010010	TRIM_CTRL_REG	Control trimming of the XTAL32M
0x50010018	XTALRDY_CTRL_REG	Control register for XTALRDY IRQ
0x5001001c	XTALRDY_STAT_REG	Difference between XTAL_OK and XTALRDY_IRQ in LP clock cycles
0x50010030	XTAL32M_CTRL0_REG	Control register for XTAL32M
0x50010034	XTAL32M_CTRL1_REG	Control register for XTAL32M
0x50010038	XTAL32M_CTRL2_REG	Control register for XTAL32M
0x5001003c	XTAL32M_CTRL3_REG	Control register for XTAL32M
0x50010050	XTAL32M_STAT0_REG	Status register for XTAL32M
0x50010054	XTAL32M_STAT1_REG	Status register for XTAL32M
0x50010060	PLL_SYS_CTRL1_REG	System PLL control register 1.
0x50010064	PLL_SYS_CTRL2_REG	System PLL control register 2.
0x50010068	PLL_SYS_CTRL3_REG	System PLL control register 3.
0x50010070	PLL_SYS_STATUS_REG	System PLL status register.
0x50020904	CLK_COM_REG	Peripheral divider register
0x50020908	SET_CLK_COM_REG	Peripheral divider register SET register. Reads back 0x0000
0x5002090c	RESET_CLK_COM_REG	Peripheral divider register RESET register. Reads back 0x0000

Address	Register	Description
0x50030c04	CLK_PER_REG	Peripheral divider register
0x50030c08	SET_CLK_PER_REG	Peripheral divider register SET register, reads 0x0000
0x50030c0c	RESET_CLK_PER_REG	Peripheral divider register RESET register, reads 0x0000
0x50030c40	PCM_DIV_REG	PCM divider and enables
0x50030c44	PCM_FDIV_REG	PCM fractional division register
0x50030c48	PDM_DIV_REG	PDM divider and enables
0x50030c4c	SRC_DIV_REG	SRC divider and enables
0x50040500	CLK_SYS_REG	Peripheral divider register
0x50040504	BATCHCHECK_REG	

Table 911: [CLK_AMBA_REG \(0x50000000\)](#)

Bit	Mode	Symbol/Description	Reset
15	R/W	QSPI2_ENABLE Clock enable for QSPI RAM controller	0x0
14:13	R/W	QSPI2_DIV QSPI divider 00 = divide by 1 01 = divide by 2 10 = divide by 4 11 = divide by 8	0x0
12	R/W	QSPI_ENABLE Clock enable for QSPI controller	0x0
11:10	R/W	QSPI_DIV QSPI divider 00 = divide by 1 01 = divide by 2 10 = divide by 4 11 = divide by 8	0x0
9	R/W	OTP_ENABLE Clock enable for OTP controller	0x0
8	R/W	TRNG_CLK_ENABLE Clock enable for TRNG block	0x0
7	R/W	- Reserved	0x0
6	R/W	AES_CLK_ENABLE Clock enable for AES crypto block	0x0
5:4	R/W	PCLK_DIV APB interface clock, Cascaded with HCLK: 00 = divide hclk by 1 01 = divide hclk by 2 10 = divide hclk by 4 11 = divide hclk by 8	0x2

Bit	Mode	Symbol/Description	Reset
3	R/W	- Reserved	0x0
2:0	R/W	HCLK_DIV AHB interface and microprocessor clock. Source clock divided by: 000 = divide clk by 1 001 = divide clk by 2 010 = divide clk by 4 011 = divide clk by 8 1xx = divide clk by 16	0x2

Table 912: CLK_RADIO_REG (0x50000010)

Bit	Mode	Symbol/Description	Reset
5	R/W	RFCU_ENABLE Enable the RF control Unit clock	0x0
4	R/W	CMAC_SYNCH_RESET Force synchronous reset to CMAC core and Sleep Timer. Its effective only when both Radio and Timer Power Domains are powered and the clocks are enabled. CMAC CPU and CMAC registers, including the retained ones, will be reset. It should be kept in reset for enough time to make sure that it will be captured by CMAC, Low Power and APB clocks.	0x1
3	R/W	CMAC_CLK_SEL Selects the clock source 1 = DIV1 clock 0 = DIVN clock	0x0
2	R/W	CMAC_CLK_ENABLE Enables the clock	0x0
1:0	R/W	CMAC_DIV Division factor for CMAC 0x0 = divide by 1 0x1 = divide by 2 0x2 = divide by 4 0x3 = divide by 8	0x0

Table 913: CLK_CTRL_REG (0x50000014)

Bit	Mode	Symbol/Description	Reset
15	R	RUNNING_AT_PLL96M Indicates that the PLL96MHz clock is used as clock, and may not be switched off	0x0
14	R	RUNNING_AT_XTAL32M Indicates that the XTAL32M clock is used as clock, and may not be switched off	0x0
13	R	RUNNING_AT_RC32M Indicates that the RC32M clock is used as clock	0x1
12	R	RUNNING_AT_LP_CLK Indicates that either the LP_CLK is being used as clock	0x0

Bit	Mode	Symbol/Description	Reset
11:7	R	- Reserved	0x0
6	R/W	- Reserved	0x1
5	R/W	- Reserved	0x0
4	R/W	USB_CLK_SRC Selects the USB source clock 0 : PLL clock, divided by 2 1 : HCLK	0x0
3:2	R/W	LP_CLK_SEL Sets the clock source of the LowerPower clock 0x0: RC32K 0x1: RCX 0x2: XTAL32K through the oscillator with an external Crystal. 0x3: XTAL32K through an external square wave generator (set PID of GPIO to FUNC_GPIO)	0x0
1:0	R/W	SYS_CLK_SEL Selects the clock source. 0x0 : XTAL32M 0x1 : RC32M 0x2 : The Low Power clock is used 0x3 : The PLL96Mhz is used	0x1

Table 914: CLK_TMR_REG (0x50000018)

Bit	Mode	Symbol/Description	Reset
2	R/W	TMR2_PWM_AON_MODE Maps Timer2_pwm onto P1_06. This state is preserved during deep sleep, to allow PWM output on the pad during deep sleep.	0x0
1	R/W	TMR_PWM_AON_MODE Maps Timer1_pwm onto P1_01 This state is preserved during deep sleep, to allow PWM output on the pad during deep sleep.	0x0
0	R/W	WAKEUPCT_ENABLE Enables the clock	0x0

Table 915: CLK_SWITCH2XTAL_REG (0x5000001C)

Bit	Mode	Symbol/Description	Reset
0	W	SWITCH2XTAL When writing to this register, the clock switch will happen from RC32M to XTAL32M. If any other clock is selected than RC32M, the selection is discarded.	0x0

Table 916: **PMU_CTRL_REG (0x50000020)**

Bit	Mode	Symbol/Description	Reset
8	R/W	ENABLE_CLKLESS Selects the clockless sleep mode. Wakeup is done asynchronously. When set to '1', the lp_clk is stopped during deep sleep, until a wakeup event (not debounced) is detected by the WAKUPCT block. When set to '0', the lp_clk continues running, so the MAC counters keep on running. This mode cannot be combined with regulated sleep, so keep SLEEP_TIMER=0 when using ENABLE_CLKLESS.	0x0
7	R/W	RETAIN_CACHE Selects the retainability of the cache block during deep sleep. '1' is retainable, '0' is power gated	0x0
6	R/W	SYS_SLEEP Put the System powerdomain (PD_SYS) in powerdown. If this bit is '1', and there is no pending IRQ in the PDC for the M33, the PD_SYS will be switched off. Wakeup should be handled by the PDC.	0x0
5	R/W	RESET_ON_WAKEUP Perform a Hardware Reset after waking up. Booter will be started.	0x0
4	R/W	MAP_BANDGAP_EN Setting this bit will: -map bandgap_enable to P0_25 -map (wokenup OR cmac_slp_timer_expire) to P0_16	0x0
3	R/W	COM_SLEEP Put the Communications powerdomain (PD_COM) in powerdown	0x1
2	R/W	TIM_SLEEP Put the Timers Powerdomain (PD_TIM) in powerdown.	0x1
1	R/W	RADIO_SLEEP Put the digital part of the radio, including CMAC (PD_RAD) in powerdown	0x1
0	R/W	PERIPH_SLEEP Put the peripherals power domain (PD_PER) in powerdown	0x1

Table 917: **SYS_CTRL_REG (0x50000024)**

Bit	Mode	Symbol/Description	Reset
15	W	SW_RESET Writing a '1' to this bit will generate a SW_RESET.	0x0
14:11	R	- Reserved	0x0
10	R/W	CACHERAM_MUX Controls accessibility of Cache RAM: 0: the cache controller is bypassed, the cacheRAM is visible in the memory space 1: the cache controller is enabled, the cacheRAM is not visible anymore in the memory space	0x0

Bit	Mode	Symbol/Description	Reset
9	R/W	TIMEOUT_DISABLE Disables timeout in Power statemachine. By default, the statemachine continues if after 2 ms the blocks are not started up. This can be read back from ANA_STATUS_REG	0x0
8	R/W	- Reserved	0x0
7	R/W	DEBUGGER_ENABLE Enable the debugger. This bit is set by the booter according to the OTP header. If not set, the SWDIO and SW_CLK can be used as gpio ports.	0x0
6	R/W	- Reserved	0x0
5	R/W	- Reserved	0x1
4	R/W	QSPI_INIT Enables QSPI initialization after wakeup	0x0
3	R/W	REMAP_INTVECT 0: normal operation 1: If ARM is in address range 0 to 0x1FF then the address is remapped to SYS-RAM 0x0080.0000 to 0x0080.01FF. This allows to put the interrupt vector table to be placed in RAM while executing from QSPI.	0x0
2:0	R/W	REMAP_ADR0 Controls which memory is located at address 0x0000 for execution. 0x0: ROM 0x1: OTP un-cached 0x2: QSPI FLASH cached (see also the CACHE_FLASH_REG.FLASH_REGION.* descriptions) Note 1: When REMAP_ADR0=0x2, address 0x0 is mapped to FLASH_REGION_BASE + FLASH_REGION_OFFSET<<2. Note 2: When REMAP_ADR0=0x2, the CPU can <u>only</u> access the Flash region [FLASH_REGION_BASE + FLASH_REGION_OFFSET<<2, FLASH_REGION_SIZE] from the 0x16000000 address range. The complete Flash can be accessed via the 0x36000000 address range but only uncached. 0x3: RAMS un-cached 0x4: QSPI FLASH un-cached (for verification only) 0x5: SYSRAM2 (for testing purposes only) 0x6: Cache Data RAM un-cached (CACHERAM_MUX=0, for testing purposes only) Note 1: DWord (64 bits) access is not supported by the Cache Data RAM interface in mirrored mode (only 32, 16 and 8 bits). Note 2: DMA access is not supported by the Cache Data RAM interface when REMAP_ADR0=0x6.	0x0

Table 918: SYS_STAT_REG (0x50000028)

Bit	Mode	Symbol/Description	Reset
13	R	POWER_IS_UP Indicates that the Startup statemachine is finished, and all power regulation is in order.	0x1

Bit	Mode	Symbol/Description	Reset
		In UltraFastWakeup mode, the SW needs to wait for this signal before starting any heavy traffic.	
12	R	DBG_IS_ACTIVE Indicates that a debugger is attached.	0x0
11	R	COM_IS_UP Indicates that PD_COM is functional	0x0
10	R	COM_IS_DOWN Indicates that PD_COM is in power down	0x1
9	R	TIM_IS_UP Indicates that PD_TIM is functional	0x0
8	R	TIM_IS_DOWN Indicates that PD_TIM is in power down	0x1
7	R	MEM_IS_UP Indicates that PD_MEM is functional	0x1
6	R	MEM_IS_DOWN Indicates that PD_MEM is in power down	0x0
5	R	SYS_IS_UP Indicates that PD_SYS is functional	0x1
4	R	SYS_IS_DOWN Indicates that PD_SYS is in power down	0x0
3	R	PER_IS_UP Indicates that PD_PER is functional	0x0
2	R	PER_IS_DOWN Indicates that PD_PER is in power down	0x1
1	R	RAD_IS_UP Indicates that PD_RAD is functional	0x0
0	R	RAD_IS_DOWN Indicates that PD_RAD is in power down	0x1

Table 919: CLK_RC32K_REG (0x5000003C)

Bit	Mode	Symbol/Description	Reset
4:1	R/W	RC32K_TRIM 0000 = lowest frequency 0111 = default 1111 = highest frequency	0x7
0	R/W	RC32K_ENABLE Enables the 32kHz RC oscillator	0x1

Table 920: CLK_XTAL32K_REG (0x50000040)

Bit	Mode	Symbol/Description	Reset
9	R/W	-	0x0

Bit	Mode	Symbol/Description	Reset
		Reserved	
8	R/W	- Reserved	0x0
7	R/W	XTAL32K_DISABLE_AMPREG Setting this bit disables the amplitude regulation of the XTAL32kHz oscillator. Set this bit to '1' for an external clock to XTAL32Kp Keep this bit '0' with a crystal between XTAL32Kp and XTAL32Km	0x0
6:3	R/W	XTAL32K_CUR Bias current for the 32kHz XTAL oscillator. 0000 is minimum, 1111 is maximum, 0011 is default. For each application there is an optimal setting for which the start-up behavior is optimal	0x5
2:1	R/W	XTAL32K_RBIAS Setting for the bias resistor. 00 is maximum, 11 is minimum. Preferred setting will be provided by Dialog	0x3
0	R/W	XTAL32K_ENABLE Enables the 32kHz XTAL oscillator	0x0

Table 921: CLK_RC32M_REG (0x50000044)

Bit	Mode	Symbol/Description	Reset
25	R/W	- Reserved	0x0
24:22	R/W	- Reserved	0x0
21:20	R/W	RC32M_INIT_RANGE Course frequency adjustment	0x1
19:12	R/W	RC32M_INIT_DEL Fine frequency adjustment	0x80
11:9	R/W	RC32M_INIT_DTCF Fine duty-cycle adjustment. 0x0: minimum 0x2: default 0x4: maximum 0x5 until 0x7: oscillator does not work.	0x2
8:5	R/W	RC32M_INIT_DTC Course duty-cycle adjustment. 0x0: minimum 0x5: default 0xA: maximum 0xB until 0xF: oscillator does not work	0x5
4:1	R/W	RC32M_BIAS Bias adjustment	0x7
0	R/W	RC32M_ENABLE Enables the 32MHz RC oscillator	0x0

Table 922: CLK_RCX_REG (0x50000048)

Bit	Mode	Symbol/Description	Reset
11:8	R/W	RCX_BIAS LDO bias current. 0x0: minimum 0xF: maximum	0xA
7	R/W	RCX_C0 Add unit capacitance to RC-time delay.	0x1
6:2	R/W	RCX_CADJUST Adjust capacitance part of RC-time delay. 0x00: minimum capacitance 0x1F: maximum capacitance	0x1F
1	R/W	RCX_RADJUST Adjust resistance part of RC-time delay. Lower resistance increases power consumption. 0x0: maximum resistance 0x1: minimum resistance	0x0
0	R/W	RCX_ENABLE Enable the RCX oscillator	0x0

Table 923: CLK_RTCDIV_REG (0x5000004C)

Bit	Mode	Symbol/Description	Reset
21	R/W	RTC_RESET_REQ Reset request for the RTC module	0x0
20	R/W	RTC_DIV_ENABLE Enable for the 100 Hz generation for the RTC block	0x0
19	R/W	RTC_DIV_DENOM Selects the denominator for the fractional division: 0b0: 1000 0b1: 1024	0x0
18:10	R/W	RTC_DIV_INT Integer divisor part for RTC 100Hz generation	0x147
9:0	R/W	RTC_DIV_FRAC Fractional divisor part for RTC 100Hz generation. if RTC_DIV_DENOM=1, <RTC_DIV_FRAC> out of 1024 cycles will divide by <RTC_DIV_INT+1>, the rest is <RTC_DIV_INT> If RTC_DIV_DENOM=0, <RTC_DIV_FRAC> out of 1000 cycles will divide by <RTC_DIV_INT+1>, the rest is <RTC_DIV_INT>	0x2A8

Table 924: BANDGAP_REG (0x50000050)

Bit	Mode	Symbol/Description	Reset
12	R/W	BANDGAP_ENABLE_CLAMP	0x0

Bit	Mode	Symbol/Description	Reset
		Enables a supply clamp inside the bandgap that improves PSRR. Should be enabled by software after cold boot.	
11:6	R/W	BGR_ITRIM Current trimming for bias	0x0
5	R/W	- Reserved	0x1
4:0	R/W	BGR_TRIM Trim register for bandgap	0x0

Table 925: **VBUS_IRQ_MASK_REG (0x50000054)**

Bit	Mode	Symbol/Description	Reset
1	R/W	VBUS_IRQ_EN_RISE Setting this bit to '1' enables VBUS_IRQ generation when the VBUS starts to ramp above threshold	0x0
0	R/W	VBUS_IRQ_EN_FALL Setting this bit to '1' enables VBUS_IRQ generation when the VBUS starts to fall below threshold	0x0

Table 926: **VBUS_IRQ_CLEAR_REG (0x50000058)**

Bit	Mode	Symbol/Description	Reset
15:0	W	VBUS_IRQ_CLEAR Writing any value to this register will reset the VBUS_IRQ line	0x0

Table 927: **BOD_CTRL_REG (0x50000060)**

Bit	Mode	Symbol/Description	Reset
17	R/W	- Reserved	0x0
16	R/W	BOD_V14_RST_EN If set, generate power-on reset on channel V14	0x1
15	R/W	BOD_V18F_RST_EN If set, generate power-on reset on channel V18F	0x1
14	R/W	BOD_VDD_RST_EN If set, generate power-on reset on channel VDD	0x1
13	R/W	BOD_V18P_RST_EN If set, generate power-on reset on channel V18P	0x1
12	R/W	BOD_V18_RST_EN If set, generate power-on reset on channel V18	0x1
11	R/W	BOD_V30_RST_EN If set, generate power-on reset on channel V30	0x1
10	R/W	BOD_VBAT_RST_EN If set, generate power-on reset on channel VBAT	0x1

Bit	Mode	Symbol/Description	Reset
9	R/W	BOD_V14_EN Enable brown-out detection for channel V14	0x0
8	R/W	BOD_V18F_EN Enable brown-out detection for channel V18F	0x0
7	R/W	BOD_VDD_EN Enable brown-out detection for channel VDD	0x1
6	R/W	BOD_V18P_EN Enable brown-out detection for channel V18P	0x0
5	R/W	BOD_V18_EN Enable brown-out detection for channel V18	0x0
4	R/W	BOD_V30_EN Enable brown-out detection for channel V30	0x0
3	R/W	BOD_VBAT_EN Enable brown-out detection for channel VBAT	0x0
2	R/W	BOD_STATUS_CLEAR Clears the brownout status register	0x0
1:0	R/W	BOD_CLK_DIV Brown-out detector clock divider. 0x0: BOD_CLK/1 0x1: BOD_CLK/2 0x2: BOD_CLK/4 0x3: BOD_CLK/8 (BOD_CLK = 1MHz)	0x0

Table 928: BOD_LVL_CTRL0_REG (0x50000064)

Bit	Mode	Symbol/Description	Reset
26:18	R/W	BOD_LVL_V18 Brown-out detection level for V18; disable the bod channel before adjusting the level setting. $V_{TH_BOD} = 1.2 * (BOD_LVL+1)/192$	0x107
17:9	R/W	BOD_LVL_V30 Brown-out detection level for V30; disable the bod channel before adjusting the level setting. $V_{TH_BOD} = 1.2 * (BOD_LVL+1)/192$	0x107
8:0	R/W	BOD_LVL_VBAT Brown-out detection level for VBAT; disable the bod channel before adjusting the level setting. $V_{TH_BOD} = 1.5 * (1.2 * (BOD_LVL+1)/192)$	0xAF

Table 929: BOD_LVL_CTRL1_REG (0x50000068)

Bit	Mode	Symbol/Description	Reset
24:17	R/W	BOD_LVL_VDD_RET Brown-out detection level for VDD in sleep; disable the bod channel before adjusting the level setting.	0x6F

Bit	Mode	Symbol/Description	Reset
		$VTH_BOD = 1.2 * (BOD_LVL+1)/192$	
16:9	R/W	BOD_LVL_VDD_ON Brown-out detection level for VDD in active; disable the bod channel before adjusting the level setting. $VTH_BOD = 1.2 * (BOD_LVL+1)/192$	0x80
8:0	R/W	BOD_LVL_V18P Brown-out detection level for V18P; disable the bod channel before adjusting the level setting. $VTH_BOD = 1.2 * (BOD_LVL+1)/192$	0x107

Table 930: BOD_LVL_CTRL2_REG (0x5000006C)

Bit	Mode	Symbol/Description	Reset
17:9	R/W	BOD_LVL_V14 Brown-out detection level for V14; disable the bod channel before adjusting the level setting. $VTH_BOD = 1.2 * (BOD_LVL+1)/192$	0xC7
8:0	R/W	BOD_LVL_V18F Brown-out detection level for V18F; disable the bod channel before adjusting the level setting. $VTH_BOD = 1.2 * (BOD_LVL+1)/192$	0x107

Table 931: P0_PAD_LATCH_REG (0x50000070)

Bit	Mode	Symbol/Description	Reset
31:0	R/W	P0_LATCH_EN Direct write to the individual pad latching signals. Latches the control signals of the pads for state retention in powerdown mode. 0 = Control signals are retained 1 = Latch is transparent, pad can be recontrolled	0xFFFF FFF

Table 932: P0_SET_PAD_LATCH_REG (0x50000074)

Bit	Mode	Symbol/Description	Reset
31:0	RWS	P0_SET_LATCH_EN Direct Set of the marked bits. Reading returns 0x0.	0x0

Table 933: P0_RESET_PAD_LATCH_REG (0x50000078)

Bit	Mode	Symbol/Description	Reset
31:0	RW1C	P0_RESET_LATCH_EN Direct Reset of the marked bits. Reading returns 0x0.	0x0

Table 934: P1_PAD_LATCH_REG (0x5000007C)

Bit	Mode	Symbol/Description	Reset
22:0	R/W	P1_LATCH_EN	

Bit	Mode	Symbol/Description	Reset
		Direct write to the individual pad latching signals. Latches the control signals of the pads for state retention in powerdown mode. 0 = Control signals are retained 1 = Latch is transparent, pad can be recontrolled	0x7FFFF F

Table 935: P1_SET_PAD_LATCH_REG (0x50000080)

Bit	Mode	Symbol/Description	Reset
22:0	RWS	P1_SET_LATCH_EN Direct Set of the marked bits. Reading returns 0x0.	0x0

Table 936: P1_RESET_PAD_LATCH_REG (0x50000084)

Bit	Mode	Symbol/Description	Reset
22:0	RW1C	P1_RESET_LATCH_EN Direct Reset of the marked bits. Reading returns 0x0.	0x0

Table 937: BOD_STATUS_REG (0x50000090)

Bit	Mode	Symbol/Description	Reset
6	R	BOD_V14 1: below trigger level (BOD event) 0: above trigger level	0x0
5	R	BOD_V18F 1: below trigger level (BOD event) 0: above trigger level	0x0
4	R	BOD_VDD 1: below trigger level (BOD event) 0: above trigger level	0x0
3	R	BOD_V18P 1: below trigger level (BOD event) 0: above trigger level	0x0
2	R	BOD_V18 1: below trigger level (BOD event) 0: above trigger level	0x0
1	R	BOD_V30 1: below trigger level (BOD event) 0: above trigger level	0x0
0	R	BOD_VBAT	0x0

Bit	Mode	Symbol/Description	Reset
		1: below trigger level (BOD event) 0: above trigger level	

Table 938: **POR_VBAT_CTRL_REG (0x50000094)**

Bit	Mode	Symbol/Description	Reset
13	R/W	POR_VBAT_MASK_N Enables propagation of the generated POR	0x1
12	R/W	POR_VBAT_ENABLE Enables generation of the POR	0x1
11:8	R/W	POR_VBAT_HYST_LOW Controls hysteresis of POR. 20mV per step. Must be set to 0x2 when thres_ctrl_low is set to 0xf.	0x2
7:4	R/W	POR_VBAT_THRES_HIGH High-side (PTAT) threshold contribution: Level --> Threshold 0x0 --> 1.25V 0x1 --> 1.27V 0x2 --> 1.29V 0x3 --> 1.31V 0x4 --> 1.44V 0x5 --> 1.49V 0x6 --> 1.53V 0x7 --> 1.58V 0x8 --> 1.63V 0x9 --> 1.68V 0xA --> 1.73V 0xB --> 1.78V 0xC --> 1.83V 0xD --> 1.87V 0xE --> 1.92V 0xF --> 1.97V	0x6
3:0	R/W	POR_VBAT_THRES_LOW Low-side (CTAT) threshold contribution Level --> Threshold 0xC --> 1.25V 0xC --> 1.27V 0xC --> 1.29V 0xC --> 1.31V 0x0 --> 1.44V 0x1 --> 1.49V 0x2 --> 1.53V 0x3 --> 1.58V 0x4 --> 1.63V 0x5 --> 1.68V	0xF

Bit	Mode	Symbol/Description	Reset
		0x6 --> 1.73V 0x7 --> 1.78V 0x8 --> 1.83V 0x9 --> 1.87V 0xA --> 1.92V 0xB --> 1.97V 0xF --> 1.63V; use only with POR_VBAT_THRES_LOW=0x6 and POR_VBAT_THRES_HYST=0x2	

Table 939: POR_PIN_REG (0x50000098)

Bit	Mode	Symbol/Description	Reset
7	R/W	POR_PIN_POLARITY 0: Active Low 1: Active High Note: This applies only for the GPIO pin. Reset pad is always active High	0x0
6	R/W	- Reserved	0x0
5:0	R/W	POR_PIN_SELECT 0x00: P0_00 ... 0x1f: P0_31 0x20: P1_00 ... 0x36: P1_22 0x37 to 0x3E: reserved 0x3F: POR generation disabled	0x3F

Table 940: POR_TIMER_REG (0x5000009C)

Bit	Mode	Symbol/Description	Reset
6:0	R/W	POR_TIME Time for the POReset to happen. Formula: Time = POR_TIME x 4096 x RC32 clock period Default value: ~3 seconds	0x18

Table 941: LDO_VDDD_HIGH_CTRL_REG (0x500000A0)

Bit	Mode	Symbol/Description	Reset
5:4	R/W	- Reserved	0x0
3	R/W	LDO_VDDD_HIGH_LOW_ZOUT_DISABLE Disables the low Zout switch. The low Zout switch pulls the output of the LDO to ground. When 0, the output of the LDO is pulled to ground when the LDO is	0x0

Bit	Mode	Symbol/Description	Reset
		disabled. When 1, the output of the LDO remains floating when the LDO is disabled.	
2	R/W	LDO_VDDD_HIGH_STATIC_LOAD_ENABLE Enables a static load of approx. 10 uA at the output of the LDO VDDD_HIGH.	0x0
1	R/W	LDO_VDDD_HIGH_ENABLE 0: LDO VDDD_HIGH off, 1: LDO VDDD_HIGH on.	0x0
0	R/W	LDO_VDDD_HIGH_VREF_HOLD 0: Indicates that the reference input is tracked, 1: Indicates that the reference input is sampled.	0x0

Table 942: **BIAS_VREF_SEL_REG (0x500000A4)**

Bit	Mode	Symbol/Description	Reset
7:4	R/W	BIAS_VREF_RF2_SEL same coding as BIAS_VREF_RF1_SEL.	0xB
3:0	R/W	BIAS_VREF_RF1_SEL Vref_code Vref_Voltage (mV) 0:900 1:930 2:960 3:990 4:1020 5:1050 6:1080 7:1110 8:1140 9:1170 10:1200 11:1230 12:1260 13:1290 14:1320 15:1350	0xB

Table 943: **RESET_STAT_REG (0x500000BC)**

Bit	Mode	Symbol/Description	Reset
5	R/W	CMAC_WDOGRESET_STAT Indicates that a CMAC-Watchdog timeout has happened. Note that it is also set when a POReset has happened.	0x1
4	R/W	SWD_HWRESET_STAT Indicates that a write to SWD_RESET_REG has happened. Note that it is also set when a POReset has happened.	0x1
3	R/W	WDOGRESET_STAT Indicates that a Watchdog timeout has happened. Note that it is also set when a POReset has happened.	0x1

Bit	Mode	Symbol/Description	Reset
2	R/W	SWRESET_STAT Indicates that a SW Reset has happened	0x1
1	R/W	HWRESET_STAT Indicates that a HW Reset has happened	0x1
0	R/W	PORESET_STAT Indicates that a PowerOn Reset has happened. All bitfields of RESET_STAT_REG should be read (in order to check the source of reset) and then cleared to '0', allowing thus the HW to automatically set to '1' the proper bitfields during the next reset event.	0x1

Table 944: RAM_PWR_CTRL_REG (0x500000C0)

Bit	Mode	Symbol/Description	Reset
15:14	R/W	RAM8_PWR_CTRL See description of RAM1_PWR_CTRL.	0x0
13:12	R/W	RAM7_PWR_CTRL See description of RAM1_PWR_CTRL.	0x0
11:10	R/W	RAM6_PWR_CTRL See description of RAM1_PWR_CTRL.	0x0
9:8	R/W	RAM5_PWR_CTRL See description of RAM1_PWR_CTRL.	0x0
7:6	R/W	RAM4_PWR_CTRL See description of RAM1_PWR_CTRL.	0x0
5:4	R/W	RAM3_PWR_CTRL See description of RAM1_PWR_CTRL.	0x0
3:2	R/W	RAM2_PWR_CTRL See description of RAM1_PWR_CTRL.	0x0
1:0	R/W	RAM1_PWR_CTRL Power state control of the individual RAMs. May only change when the memory isn't accessed. When PD_MEM_IS_UP: 0x0: Normal operation 0x1: Normal operation 0x2: Retained (no access possible) 0x3: Off (memory content corrupted) When PD_MEM_IS_DOWN: 0x0: Retained 0x1: Off (memory content corrupted) 0x2: Retained 0x3: Off (memory content corrupted)	0x0

Table 945: SECURE_BOOT_REG (0x500000CC)

Bit	Mode	Symbol/Description	Reset
7	R/W	PROT_QSPI_KEY_READ	0x0

Bit	Mode	Symbol/Description	Reset
		This bit will permanently disable CPU read capability at OTP offset 0x00000B00 and for the complete segment	
6	R/W	<p>PROT_QSPI_KEY_WRITE</p> <p>This bit will permanently disable ANY write capability at OTP offset 0x00000B00 and for the complete segment</p>	0x0
5	R/W	<p>PROT_AES_KEY_READ</p> <p>This bit will permanently disable CPU read capability at OTP offset 0x00000A00 and for the complete segment</p>	0x0
4	R/W	<p>PROT_AES_KEY_WRITE</p> <p>This bit will permanently disable ANY write capability at OTP offset 0x00000A00 and for the complete segment</p>	0x0
3	R/W	<p>PROT_SIG_KEY_WRITE</p> <p>This bit will permanently disable ANY write capability at OTP offset 0x000008C0 and for the complete segment</p>	0x0
2	R/W	<p>FORCE_CMAC_DEBUGGER_OFF</p> <p>This bit will permanently disable the CMAC debugger</p>	0x0
1	R/W	<p>FORCE_DEBUGGER_OFF</p> <p>Follows the respective OTP flag value. Its value is updated by the BootROM code. 1: The system debugger SWD is totally disabled. 0: The system debugger is enabled with DEBUGGER_ENABLE</p>	0x0
0	R/W	<p>SECURE_BOOT</p> <p>Follows the respective OTP flag value. Its value is updated by the BootROM code. 1: system is a secure system supporting secure boot 0: system is not supporting secure boot</p>	0x0

Table 946: DISCHARGE_RAIL_REG (0x500000D4)

Bit	Mode	Symbol/Description	Reset
2	R/W	<p>RESET_V18P</p> <p>1: Enables immediate discharging of the V18P rail. Note that the source is not disabled. 0: disable immediate discharging of the V18P rail. This bit is ORed with the automatic function controlled by PMU_RESET_RAIL_REG.RESET_V18P</p>	0x0
1	R/W	<p>RESET_V18</p> <p>1: Enables immediate discharging of the V18 rail. Note that the source is not disabled. 0: disable immediate discharging of the V18 rail. This bit is ORed with the automatic function controlled by PMU_RESET_RAIL_REG.RESET_V18</p>	0x0
0	R/W	<p>RESET_V14</p> <p>1: Enables immediate discharging of the V14 rail. Note that the source is not disabled. 0: disable immediate discharging of the V14 rail. This bit is ORed with the automatic function controlled by PMU_RESET_RAIL_REG.RESET_V14</p>	0x0

Table 947: ANA_STATUS_REG (0x500000EC)

Bit	Mode	Symbol/Description	Reset
14	R	COMP_VBUS_HIGH COMP_VBUS_HIGH = 1 -> VBUS > 4V	0x0
13	R	COMP_VBUS_LOW COMP_VBUS_LOW = 1 -> VBUS > 3.4V	0x0
12	R	COMP_VBAT_HIGH COMP_VBAT_HIGH = 1 -> VBAT > 2.5V	0x0
11	R	COMP_VBAT_LOW COMP_VBAT_LOW = 1 -> VBAT > 1.667V	0x0
10	R	COMP_VDD_OK COMP_VDD_OK = 1 -> VDD > 1.125V	0x0
9	R	VBUS_AVAILABLE High when VBUS > (VBAT + 150 mV). Hysteresis is approx. 40 mV	0x0
8	R	BANDGAP_OK When high bandgap is active	0x0
7	R	LDO_3V0_VBAT_OK When high LDO_VBAT is active	0x0
6	R	LDO_3V0_VBUS_OK When high LDO_VBUS is active	0x0
5	R	LDO_1V8P_OK When high LDO_IO2 is active	0x0
4	R	LDO_1V8_OK When high LDO_IO is active	0x0
3	R	LDO_RADIO_OK When high LDO_RADIO is active	0x0
2	R	LDO_CORE_OK When high LDO_CORE(LDO1V2) is active	0x0
1	R	LDO_VDD_HIGH_OK When high the ADC LDO is active. This LDO also supplies part of the LRA	0x0
0	R	BOD_VIN_NOK General output of the BOD to indicate that one of the monitored inputs is below the trigger-level.	0x0

Table 948: POWER_CTRL_REG (0x500000F0)

Bit	Mode	Symbol/Description	Reset
31:29	R/W	VDD_SLEEP_LEVEL Level setting for VDD rail when using sleep LDO 0x0: 0.75 V 0x1: 0.80 V 0x2: 0.85 V 0x3: 0.90 V 0x4: N.A.	0x0

Bit	Mode	Symbol/Description	Reset
		0x5: N.A. 0x6: N.A. 0x7: N.A.	
28:25	R/W	VDD_CLAMP_LEVEL Level setting for VDD when using clamp Typical output voltages (not regulated): 0x0: 1037 mV 0x1: 1005 mV 0x2: 978 mV 0x3: 946 mV 0x4: 1120 mV 0x5: 1089 mV 0x6: 1058 mV 0x7: 1030 mV 0x8: 952 mV 0x9: 918 mV 0xA: 889 mV 0xB: 861 mV 0xC: 862 mV 0xD: 828 mV 0xE: 798 mV 0xF: 706 mV (changed to be lower than Ido_core_ret level)	0x4
24	R/W	CLAMP_3V0_VBAT_ENABLE Enables (1) or disables (0) clamp that can supply V30 from VBAT	0x0
23	R/W	V18_LEVEL Level setting for V18 rail 0x0: 1.2 V 0x1: 1.8 V	0x1
22:20	R/W	V14_LEVEL Level setting for V14 rail 0x0: 1.20 V 0x1: 1.25 V 0x2: 1.30 V 0x3: 1.35 V 0x4: 1.40 V 0x5: 1.45 V 0x6: 1.50 V 0x7: 1.55 V	0x4
19:18	R/W	V30_LEVEL Level setting for V30 rail 0x0: 3.0 V 0x1: do not use 0x2: 3.3 V 0x3: 3.3 V	0x0
17:16	R/W	VDD_LEVEL Level setting for VDD rail	0x3

Bit	Mode	Symbol/Description	Reset
		0x0: 0.9 V 0x1: 1.0 V 0x2: 1.1 V 0x3: 1.2 V	
15	R/W	LDO_3V0_REF Selects reference source for V30 LDOs 0x0: VDD rail 0x1: Bandgap output	0x0
14	R/W	LDO_CORE_RET_ENABLE_SLEEP Enables (1) or disables (0) LDO_CORE_RET in sleep mode	0x1
13	R/W	LDO_CORE_RET_ENABLE_ACTIVE Enables (1) or disables (0) LDO_CORE_RET in active mode	0x0
12	R/W	LDO_CORE_ENABLE Enables (1) or disables (0) LDO_CORE	0x1
11	R/W	LDO_3V0_RET_ENABLE_SLEEP Enables (1) or disables (0) LDO_3V0_RET in sleep mode	0x1
10	R/W	LDO_3V0_RET_ENABLE_ACTIVE Enables (1) or disables (0) LDO_3V0_RET in active mode	0x0
9:8	R/W	LDO_3V0_MODE Controls for LDO_3V0 0x0: Disabled 0x1: LDO_VBAT enabled 0x2: LDO_VBUS enabled 0x3: Automatic selection of LDO_VBAT or LDO_VBUS	0x3
7	R/W	LDO_RADIO_ENABLE Enables (1) or disables (0) LDO_RADIO	0x1
6	R/W	LDO_1V8_RET_ENABLE_SLEEP Enables (1) or disables (0) LDO_1V8_RET in sleep mode	0x1
5	R/W	LDO_1V8_RET_ENABLE_ACTIVE Enables (1) or disables (0) LDO_1V8_RET in active mode	0x0
4	R/W	LDO_1V8_ENABLE Enables (1) or disables (0) LDO_1V8	0x1
3	R/W	SW_1V8F_ENABLE_FORCE Forces switch between V18P and V18F rails on	0x1
2	R/W	LDO_1V8P_RET_ENABLE_SLEEP Enables (1) or disables (0) LDO_1V8P_RET in sleep mode	0x1
1	R/W	LDO_1V8P_RET_ENABLE_ACTIVE Enables (1) or disables (0) LDO_1V8P_RET in active mode	0x0
0	R/W	LDO_1V8P_ENABLE Enables (1) or disables (0) LDO_1V8P	0x1

Table 949: **PMU_SLEEP_REG (0x500000F4)**

Bit	Mode	Symbol/Description	Reset
19	R/W	- Reserved	0x0
18	R/W	CLAMP_VDD_WKUP_MAX Forces the VDD clamp voltage to its maximum value when waking up from sleep.	0x0
17	R/W	ULTRA_FAST_WAKEUP Allows the core to start running on the RC32M while the PMU is still waiting for supplies to settle to the final value. Only use in combination with FAST_WAKEUP and 0.9 V on VDD during sleep.	0x0
16	R/W	FAST_WAKEUP Speeds up the wakeup process by enabling all LDOs simultaneously instead of in staggered order. Only use if all voltages have been retained during sleep.	0x1
15:12	R/W	BOD_SLEEP_INTERVAL This is a value defining the interval every which Brown Out Detection is activated to check on the power rails voltage. The value represents BG_REFRESH_INTERVALs	0x0
11:0	R/W	BG_REFRESH_INTERVAL This is a value defining the interval every which the Bandgap will be activated for refresh. The value represents ticks of lp_clk/64 e.g. 30,5 us * 64 = 1,9 ms.	0x80

Table 950: **PMU_TRIM_REG (0x500000F8)**

Bit	Mode	Symbol/Description	Reset
15:12	R/W	LDO_1V8_TRIM Trim setting for LDO_1V8 Unsigned binary notation, trim range ±10 %	0x8
11:8	R/W	LDO_1V8P_TRIM Trim setting for LDO_1V8P Unsigned binary notation, trim range ±10 %	0x8
7:4	R/W	LDO_SUPPLY_VBAT_TRIM Trim setting for LDO_SUPPLY_VBAT Sign-magnitude notation, trim range ±10 %	0x0
3:0	R/W	LDO_SUPPLY_VBUS_TRIM Trim setting for LDO_SUPPLY_VBUS Sign-magnitude notation, trim range ±10 %	0x0

Table 951: **CLK_FREQ_TRIM_REG (0x50010000)**

Bit	Mode	Symbol/Description	Reset
29:20	R/W	XTAL32M_START Xtal frequency trimming register - START phase of startup 0x2BF = lowest frequency (high load capacitance) 0x000 = highest frequency (low load capacitance) Clload = 5.0p + 6.09p * XTAL32M_TRIM/0x2BF- this includes the PCB parasitic capacitances of the reference desing	0x2BF
19:10	R/W	XTAL32M_RAMP	0x2BF

Bit	Mode	Symbol/Description	Reset
		Xtal frequency trimming register - RAMP phase of startup. 0x2BF = lowest frequency (high load capacitance) 0x000 = highest frequency (low load capacitance) Cload = 5.0p + 6.09p * XTAL32M_TRIM/0x2BF- this includes the PCB parasitic capacitances of the reference desing	
9:0	R/W	XTAL32M_TRIM Xtal frequency trimming register. 0x2BF = lowest frequency (high load capacitance) 0x000 = highest frequency (low load capacitance) Cload = 5.0p + 6.09p * XTAL32M_TRIM/0x2BF- this includes the PCB parasitic capacitances of the reference desing	0x170

Table 952: TRIM_CTRL_REG (0x50010010)

Bit	Mode	Symbol/Description	Reset
13:8	R/W	XTAL_SETTLE_N Designates that the XTAL can be safely used as the CPU clock. When XTAL_CLK_CNT reases this value, the signal XTAL_SETTLE_READY will be set	0x5
7:6	R/W	XTAL_TRIM_SELECT Select which source controls the XTAL trimming 0b00: xtal counter. Starts CLK_FREQ_TRIM_REG[XTAL32M_START] after COUNT_N * 32 xtal pulses trim is changed to CLK_FREQ_TRIM_REG[XTAL32M_TRIM]. 0b01: xtal OK filter. Starts with CLK_FREQ_TRIM_REG[XTAL32M_START], when xtal is ramping is changed to CLK_FREQ_TRIM_REG[XTAL32M_TRIM]. 0b10: statically forced off. Only uses CLK_FREQ_TRIM_REG[XTAL32M_TRIM]. 0b11: xtal OK filter, 2 stage. Starts with CLK_FREQ_TRIM_REG[XTAL32M_START] switches to CLK_FREQ_TRIM_REG[XTAL32M_RAMP] after timeout (sw1='1', XTAL32M_CTRL0_REG[XTAL32M_SW_DELAY]), and switches to CLK_FREQ_TRIM_REG[XTAL32M_TRIM] when sw2='1'.	0x0
5:0	R/W	XTAL_COUNT_N Defines the number of XTAL cycles to be counted, before the xtal trimming is applied, in steps of 32. 0x01: 32 0x02: 64 0x3f:2016	0x22

Table 953: XTALRDY_CTRL_REG (0x50010018)

Bit	Mode	Symbol/Description	Reset
8	R/W	XTALRDY_CLK_SEL XTALRDY IRQ timer clock selection: 0: 32KHz 1: 256kHz	0x1
7:0	R/W	XTALRDY_CNT Number of 32kHz or 256kHz cycles between the crystal is enabled, and the XTALRDY_IRQ is fired. Frequency set by XTALRDY_CLK_SEL. 0x00: no interrupt	0x0

Bit	Mode	Symbol/Description	Reset

Table 954: XTALRDY_STAT_REG (0x5001001C)

Bit	Mode	Symbol/Description	Reset
15:8	R	XTALRDY_COUNT Current value of IRQ counter	0x0
7:0	R	XTALRDY_STAT Value of IRQ counter when trimming is switched from RAMP to TRIM	0x0

Table 955: XTAL32M_CTRL0_REG (0x50010030)

Bit	Mode	Symbol/Description	Reset
31	R/W	- Reserved	0x0
30	R/W	XTAL32M_DXTAL_SYSPLL_ENABLE Enables DXTAL for the system PLL.	0x0
29	R/W	- Reserved	0x0
28:26	R/W	- Reserved	0x2
25	R/W	- Reserved	0x1
24:22	R/W	- Reserved	0x6
21	R/W	- Reserved	0x0
20:18	R/W	- Reserved	0x0
17:15	R/W	XTAL32M_CORE_CUR_SET Core current trim setting. 0x0: min current ... 0x3: default current ... 0x6 max amplitude 0x7 is equal to 0x3.	0x5
14	R/W	- Reserved	0x1
13	R/W	- Reserved	0x1
12	R/W	- Reserved	0x0

Bit	Mode	Symbol/Description	Reset
11	R/W	- Reserved	0x0
10	R/W	- Reserved	0x1
9	R/W	- Reserved	0x1
8	R/W	- Reserved	0x0
7	R/W	- Reserved	0x1
6	R/W	- Reserved	0x0
5	R/W	- Reserved	0x1
4	R/W	- Reserved	0x1
3	R/W	XTAL32M_RCOSC_CALIBRATE Request an RC-oscillator calibration. If set, calibration will be started after xtal startup.	0x0
2	R/W	- Reserved	0x1
1	R/W	XTAL32M_RCOSC_XTAL_DRIVE Enable drive of crystal by RCOSC, needed for fast startup	0x0
0	R/W	XTAL32M_CXCOMP_ENABLE Enable the shunt-capacitance compensation amplifier circuit (OSF BOOST).	0x0

Table 956: XTAL32M_CTRL1_REG (0x50010034)

Bit	Mode	Symbol/Description	Reset
31	R/W	- Reserved	0x0
30:28	R/W	XTAL32M_STARTUP_TDISCHARGE Discharge time. 0x0: disable 0x1: 8 us 0x2: 4 us 0x3: 2 us 0x4: 1 us 0x5: 1/2 us 0x6: 1/8 us 0x7: 1/32 us	0x7
27	R/W	- Reserved	0x0

Bit	Mode	Symbol/Description	Reset
26:24	R/W	XTAL32M_STARTUP_TSETTLE Settle time. 0x0: 16 us 0x1: 8 us 0x2: 4 us 0x3: 2 us 0x4: 1 us 0x5: 1/2 us 0x6: 1/4 us 0x7: 1/8 us	0x5
23	R/W	XTAL32M_XTAL_ENABLE Enable xtal (startup) or enable xtal block (software control mode) - testing only, to enable xtal, use PDC.	0x0
22:13	R/W	XTAL32M_STARTUP_TDRIVE_LSB LSB part of the sequence drive time. From 0 to 32us with steps of 1/32us.	0x1F
12:8	R/W	XTAL32M_DRIVE_CYCLES Number of sequences to drive at startup.	0x8
7:5	R/W	XTAL32M_STARTUP_TDRIVE Drive time of the sequence. 0x0: 32 us 0x1: 16 us 0x2: 8 us 0x3: 4 us 0x4: 2 us 0x5: 1 us 0x6: 1/2 us 0x7: 1/4 us	0x5
4:0	R/W	XTAL32M_RCOSC_SYNC_DELAY_TRIM Synchronization mode delay trim..	0x4

Table 957: XTAL32M_CTRL2_REG (0x50010038)

Bit	Mode	Symbol/Description	Reset
31:24	R/W	- Reserved	0x0
23:22	R/W	- Reserved	0x0
21:14	R/W	XTAL32M_RCOSC_TRIM_SNS Trim sensitivity used during calibration of the RC-oscillator. $XTAL_RCOSC_TRIM_SNS = 128 / (M0 * S)$ M0=8196 S = sensitivity of RCOSC (~128ppm/LSB) Using the internal frequency counter $S = (FreqDetHigh - FreqDetLow) / (M * D)$	0x79

Bit	Mode	Symbol/Description	Reset
		FreqDetHigh, FreqDetLow: the frequency counter reading (XTAL32M_STAT0_REG.FREQ_DET_OUT) at trim setting T0 and T1 (XTAL32M_CTRL3_REG.XTAL32M_RCOSC_TRIM) D = T0 - T1 M -> see XTAL32M_CTRL2_REG.XTAL32M_FREQ_DET_LEN XTAL_RCOSC_TRIM_SNS = 64 * D / (FreqDetHigh-FreqDetLow), when XTAL32M_FREQ_DET_LEN = 1	
13:12	R/W	XTAL32M_CXCOMP_PHI_TRIM Phase correction for cxcomp circuit.	0x0
11:3	R/W	XTAL32M_CXCOMP_TRIM_CAP Size of shunt capacitance compensation cap	0x0
2:0	R/W	- Reserved	0x7

Table 958: XTAL32M_CTRL3_REG (0x5001003C)

Bit	Mode	Symbol/Description	Reset
31	R/W	- Reserved	0x0
30	R/W	XTAL32M_RCOSC_TRIM_STROBE Force RC-oscillator trim setting.	0x0
29	R/W	- Reserved	0x0
28	R/W	- Reserved	0x0
27	R/W	- Reserved	0x0
26	R/W	- Reserved	0x0
25	R/W	- Reserved	0x0
24	R/W	- Reserved	0x0
23	R/W	- Reserved	0x0
22	R/W	XTAL32M_FREQ_DET_START Force start frequency detector.	0x0
21	R/W	- Reserved	0x0
20	R/W	- Reserved	0x0
19	R/W	- Reserved	0x1

Bit	Mode	Symbol/Description	Reset
18	R/W	XTAL32M_SW_CTRL_MODE Enable all the software overrides, the state-machine will remain in IDLE.	0x0
17:14	R/W	XTAL32M_RCOSC_BAND_SELECT Set RCOSC band select - apply with RCOSC_TRIM_STROBE	0x5
13:4	R/W	XTAL32M_RCOSC_TRIM Set RCOSC trim (fine) - apply with RCOSC_TRIM_STROBE	0x225
3	R/W	- Reserved	0x0
2	R/W	- Reserved	0x1
1	R/W	- Reserved	0x0
0	R/W	- Reserved	0x1

Table 959: XTAL32M_STAT0_REG (0x50010050)

Bit	Mode	Symbol/Description	Reset
31:28	R	XTAL32M_RCOSC_BAND_SELECT_STAT Currently selected band.	0x0
27:18	R	- Reserved	0x0
17	R	- Reserved	0x0
16	R	- Reserved	0x0
15	R	XTAL32M_RCOSC_CALIBRATION_DONE Signals that the calibration phase has been completed.	0x0
14	R	- Reserved	0x0
13:0	R	- Reserved	0x0

Table 960: XTAL32M_STAT1_REG (0x50010054)

Bit	Mode	Symbol/Description	Reset
31:27	R	- Reserved	0x0
26	R	- Reserved	0x0
25	R	- Reserved	0x0

Bit	Mode	Symbol/Description	Reset
24	R	- Reserved	0x0
23	R	- Reserved	0x0
22:11	R	- Reserved	0x0
10	R	- Reserved	0x0
9	R	- Reserved	0x0
8	R	- Reserved	0x0
7:4	R	XTAL32M_CAL_STATE Current state of the calibration state-machine. 0x0: CAL_DELAY - Delay for the biasing to settle 0x1: CAL_SYNC - Enables synchronization circuit 0x2: CAL_FREQDET - Enables the frequency detector 0x3: CAL_OFFSET - Evaluate OFFSET trimresult 0x4: CAL_MULT_SHIFT - Evaluate (delta) trimresult 0x5: CAL_TRIM - Generate new trimvalue 0x6: CAL_BAND_UPDOWN - Delay after band change 0x7: CAL_END - Calibration ended 0x8: CAL_IDLE - Calibration IDLE (default state)	0x0
3:0	R	XTAL32M_STATE Current state of the startup state-machine. 0x0: XTAL_WAIT_LDO - Allow for setting of the biasing 0x1: XTAL_DRIVE - Crystal is driven by rcosc 0x2: XTAL_DISCHARGE - Discharge loadcaps 0x3: XTAL_SETTLE - Allows for settling of the xtal signal 0x4: XTAL_SYNC - Restart RCOSC, and synchronize 0x5: XTAL_OVERLOAD_DETECT - amplitude detection mode by overload bit 0x6: XTAL_OVERLOAD_BLANK_SETTLE - setting delay for amplitude regulator when drive ends 0x7: XTAL_OVERLOAD_BLANK - blank glitch from enabling gm_current 0x8: XTAL_RUN - Startup ended 0x9: XTAL_SAMPLE - Delay before sample amplitude control 0xa: XTAL_SW2_MASK - Delay for masked SW2 0xb: XTAL_IDLE - Idle state (default)	0x0

Table 961: **PLL_SYS_CTRL1_REG (0x50010060)**

Bit	Mode	Symbol/Description	Reset
15	R/W	- Reserved	0x0

Bit	Mode	Symbol/Description	Reset
14	R/W	PLL_SEL_MIN_CUR_INT 0: VCO current read from min_current <5:0>, 1: VCO current is internally determined with a calibration algorithm.	0x1
13:12	R/W	- Reserved	0x2
11	R/W	PLL_PRE_DIV PLL input divider (1: Indicates divide by 2).	0x1
10:4	R/W	PLL_N_DIV PLL loop divider N (x means divide by x, 0 means divide by 1)	0x6
3	R/W	LDO_PLL_VREF_HOLD 0: Indicates that the reference input is tracked, 1: Indicates that the reference input is sampled.	0x0
2	R/W	LDO_PLL_ENABLE 0: LDO PLL off, 1: LDO PLL on.	0x0
1	R/W	PLL_EN 0: Power down 1: PLL on	0x0
0	R/W	- Reserved	0x0

Table 962: PLL_SYS_CTRL2_REG (0x50010064)

Bit	Mode	Symbol/Description	Reset
31:16	R	- Reserved	0x0
15	R/W	PLL_RECALIB Recalibrate	0x0
14:10	R/W	- Reserved	0x3
9:5	R/W	- Reserved	0x0
4:0	R/W	- Reserved	0x0

Table 963: PLL_SYS_CTRL3_REG (0x50010068)

Bit	Mode	Symbol/Description	Reset
15:13	R/W	- Reserved	0x4
12	R/W	- Reserved	0x0
11	R/W	-	0x0

Bit	Mode	Symbol/Description	Reset
		Reserved	
10	R/W	- Reserved	0x0
9	R/W	- Reserved	0x0
8	R/W	- Reserved	0x0
7	R/W	PLL_TEST_VCTR 1: map loopfilter voltage on external pin <tbid>	0x0
6:1	R/W	PLL_MIN_CURRENT VCO current trimming.	0x38
0	R/W	- Reserved	0x0

Table 964: PLL_SYS_STATUS_REG (0x50010070)

Bit	Mode	Symbol/Description	Reset
15	R	LDO_PLL_OK 1: Indicates that LDO PLL is in regulation.	0x0
14:12	R	- Reserved	0x0
11	R	PLL_CALIBRATION_END Indicates that calibration has finished.	0x0
10:5	R	PLL_BEST_MIN_CUR Calibrated VCO current.	0x0
4:1	R	- Reserved	0x0
0	R	PLL_LOCK_FINE 1: PLL locked	0x0

Table 965: CLK_COM_REG (0x50020904)

Bit	Mode	Symbol/Description	Reset
17:16	R/W	LCD_EXT_CLK_SEL Select LCD external clock speed. 0x0: 1 Hz 0x1: 62.5 Hz 0x2: 125 Hz 0x3: off	0x3
15:14	R/W	SNC_DIV Division factor for SNC, w.r.t. pclk setting 0x0 = divide by 1 0x1 = divide by 2	0x0

Bit	Mode	Symbol/Description	Reset
		0x2 = divide by 4 0x3 = divide by 8	
13	R/W	- Reserved	0x0
12	R/W	I2C2_CLK_SEL Selects the clock source 1 = DIV1 clock 0 = DIVN clock	0x0
11	R/W	I2C2_ENABLE Enables the clock	0x0
10	R/W	I2C_CLK_SEL Selects the clock source 1 = DIV1 clock 0 = DIVN clock	0x0
9	R/W	I2C_ENABLE Enables the clock	0x0
8	R/W	SPI2_CLK_SEL Selects the clock source 1 = DIV1 clock 0 = DIVN clock	0x0
7	R/W	SPI2_ENABLE Enables the clock	0x0
6	R/W	SPI_CLK_SEL Selects the clock source 1 = DIV1 clock 0 = DIVN clock	0x0
5	R/W	SPI_ENABLE Enables the clock	0x0
4	R/W	UART3_CLK_SEL Selects the clock source 1 = DIV1 clock 0 = DIVN clock	0x0
3	R/W	UART3_ENABLE Enables the clock	0x0
2	R/W	UART2_CLK_SEL Selects the clock source 1 = DIV1 clock 0 = DIVN clock	0x0
1	R/W	UART2_ENABLE Enables the clock	0x0
0	R/W	UART_ENABLE Enables the clock	0x0

Table 966: SET_CLK_COM_REG (0x50020908)

Bit	Mode	Symbol/Description	Reset
17:16	RWS	LCD_EXT_CLK_SEL Select LCD external clock speed. 0x0: 1 Hz 0x1: 62.5 Hz 0x2: 125 Hz 0x3: off	0x0
15:14	RWS	SNC_DIV Division factor for SNC, w.r.t. pclk setting 0x0 = divide by 1 0x1 = divide by 2 0x2 = divide by 4 0x3 = divide by 8	0x0
13	RWS	- Reserved	0x0
12	RWS	I2C2_CLK_SEL Selects the clock source 1 = DIV1 clock 0 = DIVN clock	0x0
11	RWS	I2C2_ENABLE Enables the clock	0x0
10	RWS	I2C_CLK_SEL Selects the clock source 1 = DIV1 clock 0 = DIVN clock	0x0
9	RWS	I2C_ENABLE Enables the clock	0x0
8	RWS	SPI2_CLK_SEL Selects the clock source 1 = DIV1 clock 0 = DIVN clock	0x0
7	RWS	SPI2_ENABLE Enables the clock	0x0
6	RWS	SPI_CLK_SEL Selects the clock source 1 = DIV1 clock 0 = DIVN clock	0x0
5	RWS	SPI_ENABLE Enables the clock	0x0
4	RWS	UART3_CLK_SEL Selects the clock source 1 = DIV1 clock 0 = DIVN clock	0x0

Bit	Mode	Symbol/Description	Reset
3	RWS	UART3_ENABLE Enables the clock	0x0
2	RWS	UART2_CLK_SEL Selects the clock source 1 = DIV1 clock 0 = DIVN clock	0x0
1	RWS	UART2_ENABLE Enables the clock	0x0
0	RWS	UART_ENABLE Enables the clock	0x0

Table 967: RESET_CLK_COM_REG (0x5002090C)

Bit	Mode	Symbol/Description	Reset
17:16	RW1C	LCD_EXT_CLK_SEL Select LCD external clock speed. 0x0: 1 Hz 0x1: 62.5 Hz 0x2: 125 Hz 0x3: off	0x0
15:14	RW1C	SNC_DIV Division factor for SNC, w.r.t. pclk setting 0x0 = divide by 1 0x1 = divide by 2 0x2 = divide by 4 0x3 = divide by 8	0x0
13	RW1C	- Reserved	0x0
12	RW1C	I2C2_CLK_SEL Selects the clock source 1 = DIV1 clock 0 = DIVN clock	0x0
11	RW1C	I2C2_ENABLE Enables the clock	0x0
10	RW1C	I2C_CLK_SEL Selects the clock source 1 = DIV1 clock 0 = DIVN clock	0x0
9	RW1C	I2C_ENABLE Enables the clock	0x0
8	RW1C	SPI2_CLK_SEL Selects the clock source 1 = DIV1 clock 0 = DIVN clock	0x0

Bit	Mode	Symbol/Description	Reset
7	RW1C	SPI2_ENABLE Enables the clock	0x0
6	RW1C	SPI_CLK_SEL Selects the clock source 1 = DIV1 clock 0 = DIVN clock	0x0
5	RW1C	SPI_ENABLE Enables the clock	0x0
4	RW1C	UART3_CLK_SEL Selects the clock source 1 = DIV1 clock 0 = DIVN clock	0x0
3	RW1C	UART3_ENABLE Enables the clock	0x0
2	RW1C	UART2_CLK_SEL Selects the clock source 1 = DIV1 clock 0 = DIVN clock	0x0
1	RW1C	UART2_ENABLE Enables the clock	0x0
0	RW1C	UART_ENABLE Enables the clock	0x0

Table 968: CLK_PER_REG (0x50030C04)

Bit	Mode	Symbol/Description	Reset
12:8	R/W	MC_TRIG_DIV Trigger divider for the motor controller 0x0: divide LP_CLK by 1 0x1: divide LP_CLK by 2 ... 0x1F: divide LP_CLK by 32	0x0
7:3	R/W	MC_CLK_DIV Clock divider for the motor controller slot. The slots are clocked on (a PCLK synchronized version of) the LP clock, and can be further divided by this divider: 0x0: divide LP clock by 1 0x1: divide LP clock by 2 ... 0x1F: divide LP clock by 32	0x0
2	R/W	MC_CLK_EN Enables the clock	0x0
1	R/W	LRA_CLK_EN Enables the clock	0x0
0	R/W	GPADC_CLK_SEL	0x0

Bit	Mode	Symbol/Description	Reset
		Selects the clock source 1 = DIV1 clock 0 = DIVN clock/ 2	

Table 969: SET_CLK_PER_REG (0x50030C08)

Bit	Mode	Symbol/Description	Reset
12:8	RWS	MC_TRIG_DIV Trigger divider for the motor controller 0x0: divide LP_CLK by 1 0x1: divide LP_CLK by 2 ... 0x1F: divide LP_CLK by 32	0x0
7:3	RWS	MC_CLK_DIV Clock divider for the motor controller slot. The slots are clocked on (a PCLK synchronized version of) the LP clock, and can be further divided by this divider: 0x0: divide LP clock by 1 0x1: divide LP clock by 2 ... 0x1F: divide LP clock by 32	0x0
2	RWS	MC_CLK_EN Enables the clock	0x0
1	RWS	LRA_CLK_EN Enables the clock	0x0
0	RWS	GPADC_CLK_SEL Selects the clock source 1 = DIV1 clock 0 = DIVN clock/ 2	0x0

Table 970: RESET_CLK_PER_REG (0x50030C0C)

Bit	Mode	Symbol/Description	Reset
12:8	RW1C	MC_TRIG_DIV Trigger divider for the motor controller 0x0: divide LP_CLK by 1 0x1: divide LP_CLK by 2 ... 0x1F: divide LP_CLK by 32	0x0
7:3	RW1C	MC_CLK_DIV Clock divider for the motor controller slot. The slots are clocked on (a PCLK synchronized version of) the LP clock, and can be further divided by this divider: 0x0: divide LP clock by 1 0x1: divide LP clock by 2 ... 0x1F: divide LP clock by 32	0x0
2	RW1C	MC_CLK_EN	0x0

Bit	Mode	Symbol/Description	Reset
		Enables the clock	
1	RW1C	LRA_CLK_EN Enables the clock	0x0
0	RW1C	GPADC_CLK_SEL Selects the clock source 1 = DIV1 clock 0 = DIVN clock/ 2	0x0

Table 971: **PCM_DIV_REG (0x50030C40)**

Bit	Mode	Symbol/Description	Reset
13	R/W	PCM_SRC_SEL Selects the clock source 1 = DIV1 clock 0 = DIVN clock	0x0
12	R/W	CLK_PCM_EN Enable for the internally generated PCM clock The PCM_DIV must be set before or together with CLK_PCM_EN.	0x0
11:0	R/W	PCM_DIV PCM clock divider. Minimum value is 0x2.	0x0

Table 972: **PCM_FDIV_REG (0x50030C44)**

Bit	Mode	Symbol/Description	Reset
15:0	R/W	PCM_FDIV These bits define the fractional division part of the PCM clock. The left most '1' defines the denominator, the number of '1' bits define the numerator. E.g. 0x0110 means 2/9, with a distribution of 1.0001.0000 0xfeee means 13/16, with a distribution of 1111.1110.1110.1110	0x0

Table 973: **PDM_DIV_REG (0x50030C48)**

Bit	Mode	Symbol/Description	Reset
9	R/W	PDM_MASTER_MODE Master mode selection 0: slave mode 1: master mode	0x0
8	R/W	CLK_PDM_EN Enable for the internally generated PDM clock The PDM_DIV must be set before or together with CLK_PDM_EN.	0x0
7:0	R/W	PDM_DIV PDM clock divider	0x0

Table 974: SRC_DIV_REG (0x50030C4C)

Bit	Mode	Symbol/Description	Reset
8	R/W	CLK_SRC_EN Enable for the internally generated SRC clock The SRC_DIV must be set before or together with CLK_SRC_EN.	0x0
7:0	R/W	SRC_DIV SRC clock divider	0x0

Table 975: CLK_SYS_REG (0x50040500)

Bit	Mode	Symbol/Description	Reset
5	R/W	CLK_CHG_EN Enables the clocks for the charger FSM block	0x0
4	R/W	LCD_RESET_REQ Generates a SW reset towards the LCD controller.	0x0
3:2	R/W	- Reserved	0x0
1	R/W	LCD_CLK_SEL Selects the clock source 1 = DIV1 clock 0 = DIVN clock	0x0
0	R/W	LCD_ENABLE Enables the clock	0x0

Table 976: BATCHECK_REG (0x50040504)

Bit	Mode	Symbol/Description	Reset
7	R/W	BATCHECK_LOAD_ENABLE Enable a current load on the battery.	0x0
6:4	R/W	BATCHECK_ILOAD Set the current load to (ILOAD+1) mA.	0x0
3:0	R/W	BATCHECK_TRIM Trim the current load with steps of 2.7% from -19.1% to +19.1%. 0: +0.0% , 8: -0% 1: +2.7% , 9: -2.7% 2: +5.5% , 10: -5.5% 3: +8.2% , 11: -8.2% 4: +10.9% , 12: -10.9% 5: +13.6% , 13: -13.6% 6: +16.4% , 14: -16.4% 7: +19.1% , 15: -19.1%	0x0

42.30 Cache Controller Registers

Table 977: Register map CACHE

Address	Register	Description
0x100C0000	CACHE_CTRL1_REG	Cache control register 1
0x100C0004	CACHE_LNSIZECFG_REG	Cache line size configuration register
0x100C0008	CACHE ASSOCCFG_REG	Cache associativity configuration register
0x100C0020	CACHE_CTRL2_REG	Cache control register 2
0x100C0028	CACHE_MRM_HITS_REG	Cache MRM (Miss Rate Monitor) HITS register
0x100C002C	CACHE_MRM_MISSES_REG	Cache MRM (Miss Rate Monitor) MISSES register
0x100C0030	CACHE_MRM_CTRL_REG	Cache MRM (Miss Rate Monitor) CONTROL register
0x100C0034	CACHE_MRM_TINT_REG	Cache MRM (Miss Rate Monitor) TIME INTERVAL register
0x100C0038	CACHE_MRM_MISSES_THRES_REG	Cache MRM (Miss Rate Monitor) THRESHOLD register
0x100C003C	CACHE_MRM_HITS_THRES_REG	Cache MRM (Miss Rate Monitor) HITS THRESHOLD register
0x100C0040	CACHE_FLASH_REG	Cache Flash program size and base address register
0x100C0050	SWD_RESET_REG	SWD HW reset control register

Table 978: CACHE_CTRL1_REG (0x100C0000)

Bit	Mode	Symbol	Description	Reset
31:2	-	-	Reserved	0
1	R/W	CACHE_RES1	Reserved. Always keep 0.	0
0	R0/W	CACHE_FLUSH	Writing a '1' into this bit, flushes the contents of the tag memories which invalidates the content of the cache memory. The read of this bit is always '0'. Note: The flushing of the cache TAG memory takes 0x100 or 0x200 HCLK cycles for a Cache Data RAM size of 8 KB resp. 16 KB.	0

Table 979: CACHE_LNSIZECFG_REG (0x100C0004)

Bit	Mode	Symbol	Description	Reset
31:2	-	-	Reserved	0
1:0	R/W	CACHE_LINE	Cache line size: 0: 8 bytes, 1: 16 bytes, 2: 32 bytes, 3: reserved. Note: Flush the cache just after the dynamic (run-time) reconfiguration of the cache with an 8 bytes cache line size: write the value "01" into the cache control register CACHE_CTRL1_REG just after the write of the value	0

Bit	Mode	Symbol	Description	Reset
			"00" into the cache line size configuration register CACHE_LNSIZECFG_REG.	

Table 980: **CACHE_ASSOCCFG_REG (0x100C0008)**

Bit	Mode	Symbol	Description	Reset
31:2	-	-	Reserved	0
1:0	R/W	CACHE_ASSOC	Cache associativity: 0: 1-way (direct mapped) 1: 2-way 2: 4-way 3: reserved.	2

Table 981: **CACHE_CTRL2_REG (0x100C0020)**

Bit	Mode	Symbol	Description	Reset
31:11	-	-	Reserved	0
10	R/W	CACHE_CGEN	0: Cache controller clock gating is not enabled. 1: Cache controller clock gating is enabled (enabling power saving). Note: This bit must be set to '0' (default) when setting the CACHE_FLUSH bit while executing from other than QSPI FLASH cached, e.g. from Booter or SYSRAM.	0
9	R/W	CACHE_WEN	0: Cache Data and TAG memory read only. 1: Cache Data and TAG memory read/write. The TAG and Data memory are only updated by the cache controller. There is no HW protection to prevent unauthorized access by the ARM. Note: When accessing the memory mapped Cache Data and TAG memory (for debugging purposes) only 32 bits access is allowed to the Cache Data memory and only 16 bits access is allowed to the Cache TAG memory.	0
8:0	R/W	CACHE_LEN	Length of QSPI FLASH cacheable memory. N*64 KByte. N = 0 to 512 (max. of 32 Mbyte). Setting CACHE_LEN=0 disables the cache. Note 1: The max. relevant CACHE_LEN setting depends on the chosen Flash region (program) size. Note 2: The first block (CACHE_LEN=1) includes the memory space specified by CACHE_FLASH_REG[FLASH_REGION_OFFSET].	0

Table 982: **CACHE_MRM_HITS_REG (0x100C0028)**

Bit	Mode	Symbol	Description	Reset
31:0	R/W	MRM_HITS	Contains the amount of cache hits.	0x0

Table 983: **CACHE_MRM_MISSES_REG** (0x100C002C)

Bit	Mode	Symbol	Description	Reset
31:0	R/W	MRM_MISSES	Contains the amount of cache misses.	0x0

Table 984: **CACHE_MRM_CTRL_REG** (0x100C0030)

Bit	Mode	Symbol	Description	Reset
31:5	-	-	Reserved	0
4	R/W	MRM_IRQ_HITS_THRES_STATUS	0: No interrupt is generated. 1: Interrupt (pulse-sensitive) is generated because the number of cache hits reached the programmed threshold (threshold != 0).	0
3	R/W	MRM_IRQ_MISSES_THRES_STATUS	0: No interrupt is generated. 1: Interrupt (pulse-sensitive) is generated because the number of cache misses reached the programmed threshold (threshold != 0).	0
2	R/W	MRM_IRQ_TINT_STATUS	0: No interrupt is generated. 1: Interrupt (pulse-sensitive) is generated because the time interval counter reached the end (time interval != 0).	0
1	R/W	MRM_IRQ_MASK	0: Disables interrupt generation. 1: Enables interrupt generation. Note: The Cache MRM generates a pulse-sensitive interrupt towards the ARM processor,	0
0	R/W	MRM_START	0: Freeze the "misses/hits" counters and reset the time interval counter to the programmed value in CACHE_MRM_TINT_REG. 1: Enables the counters. Note: In case CACHE_MRM_CTRL_REG[MRM_START] is set to '1' and CACHE_MRM_TINT_REG (!=0) is used for the MRM interrupt generation, the time interval counter counts down (on a fixed reference clock of 16 MHz) until it's '0'. At that time CACHE_MRM_CTRL_REG[MRM_START] will be reset automatically to '0' by the MRM hardware and the MRM interrupt will be generated.	0

Table 985: **CACHE_MRM_TINT_REG** (0x100C0034)

Bit	Mode	Symbol	Description	Reset
31:19	-	-	Reserved	0x0
18:0	R/W	MRM_TINT	Defines the time interval for the monitoring in 32 MHz clock cycles. See also the description of CACHE_MRM_CTRL_REG[MRM_IRQ_TINT_STATUS]. Note: When MRM_TINT=0 (unrealistic value), no interrupt will be generated.	0x0

Table 986: **CACHE_MRM_MISSES_THRES_REG (0x100C0038)**

Bit	Mode	Symbol	Description	Reset
31:0	R/W	MRM_MISSES_THRES	Defines the misses threshold to trigger the interrupt generation. See also the description of CACHE_MRM_CTRL_REG[MRM_IRQ_MISSES_THRES_STATUS]. Note: When MRM_MISSES_THRES=0 (unrealistic value), no interrupt will be generated.	0x0

Table 987: **CACHE_MRM_HITS_THRES_REG (0x100C003C)**

Bit	Mode	Symbol	Description	Reset
31:0	R/W	MRM_HITS_THRES	Defines the hits threshold to trigger the interrupt generation. See also the description of CACHE_MRM_CTRL_REG[MRM_IRQ_HITS_THRES_STATUS]. Note: When MRM_HITS_THRES=0 (unrealistic value), no interrupt will be generated.	0x0

Table 988: **CACHE_FLASH_REG (0x100C0040)**

Bit	Mode	Symbol	Description	Reset
31:16	R/W	FLASH_REGION_BASE	These bits corresponds with the Flash region base address bits [31:16]. Default value is '0x1600'. The Flash region base address bits [31:25] are fixed to '0x16' and bits [17:16] are fixed to '0x0'. These register bits are retained. Note 1: The updated value takes effect only after a software reset. Note 2 The Flash region base address setting depends on the chosen Flash region size.	0x1600
15:4	R/W	FLASH_REGION_OFFSET	Flash region offset address (in words). This value is added to the Flash (CPU) address bits [13:2]. These register bits are retained. Note 1: The updated value takes effect only after a software reset.	0x0
3	R	-	Reserved	0x0
2:0	R/W	FLASH_REGION_SIZE	Flash region size. Default value is '6' (0.5 MBytes). 0 = 32 MBytes, 1 = 16 MBytes, 2 = 8 MBytes, 3 = 4 MBytes, 4 = 2 MBytes, 5 = 1 MBytes, 6 = 0.5 MBytes, 7 = 0.25 MBytes. These register bits are retained.	0x6

Bit	Mode	Symbol	Description	Reset
			Note 1: The updated value takes effect only after a software reset. Note 2: See for the max. region (program) size the memory map.	

Table 989: SWD_RESET_REG (0x100C0050)

Bit	Mode	Symbol	Description	Reset
31:1	-	-	Reserved	0
0	R0/W	SWD_HW_RESET_REQ	0: default. 1: HW reset request (from the debugger tool). The register is automatically reset with a HW_RESET. This bit can only be accessed by the debugger software and not by the application.	0

42.31 Audio Unit Registers

Table 990: Register map APU

Address	Register	Description
0x50030600	SRC1_CTRL_REG	SRC1 control register
0x50030604	SRC1_IN_FS_REG	SRC1 Sample input rate
0x50030608	SRC1_OUT_FS_REG	SRC1 Sample output rate
0x5003060C	SRC1_IN1_REG	SRC1 data in 1
0x50030610	SRC1_IN2_REG	SRC1 data in 2
0x50030614	SRC1_OUT1_REG	SRC1 data out 1
0x50030618	SRC1_OUT2_REG	SRC1 data out 2
0x5003061C	APU_MUX_REG	APU mux register
0x50030620	COEF10_SET1_REG	SRC coefficient 1,0 set 1
0x50030624	COEF32_SET1_REG	SRC coefficient 3,2 set 1
0x50030628	COEF54_SET1_REG	SRC coefficient 5,4 set 1
0x5003062C	COEF76_SET1_REG	SRC coefficient 7,6 set 1
0x50030630	COEF98_SET1_REG	SRC coefficient 9,8 set 1
0x50030634	COEF0A_SET1_REG	SRC coefficient 10 set 1
0x50030700	PCM1_CTRL_REG	PCM1 Control register
0x50030704	PCM1_IN1_REG	PCM1 data in 1
0x50030708	PCM1_IN2_REG	PCM1 data in 2
0x5003070C	PCM1_OUT1_REG	PCM1 data out 1
0x50030710	PCM1_OUT2_REG	PCM1 data out 2

Table 991: SRC1_CTRL_REG (0x50030600)

Bit	Mode	Symbol	Description	Reset
31:30	R/W	SRC_PDM_DO_DEL	PDM_DO output delay line (typical) 0: no delay 1: 8 ns 2: 12 ns 3: 16 ns	0
29:28	R/W	SRC_PDM_MODE	PDM Output mode selection on PDM_DO1 00: No output 01: Right channel (data from SRC1_IN_REG) 10: Left channel (data from SRC2_IN_REG) 11: Left and Right channel	0
27:26	R/W	SRC_PDM_DI_DEL	PDM_DI input delay line (typical) 0: no delay 1: 4 ns 2: 8 ns 3: 12 ns	0
25	R0/W	SRC_OUT_FLOWCLR	Writing a 1 clears the SRC1_OUT Overflow/underflow bits 23-22. No more over/underflow indications while bit is 1. Keep 1 until the over/under flow bit is cleared	0
24	W	SRC_IN_FLOWCLR	Writing a 1 clears the SRC1_IN Overflow/underflow bits 21-20. No more over/underflow indications while bit is 1. Keep 1 until the over/under flow bit is cleared	0
23	R	SRC_OUT_UNFLOW	1 = SRC1_OUT Underflow occurred	0
22	R	SRC_OUT_OVFLOW	1 = SRC1_OUT Overflow occurred	0
21	R	SRC_IN_UNFLOW	1 = SRC1_IN Underflow occurred	0
20	R	SRC_IN_OVFLOW	1 = SRC1_IN Overflow occurred	0
19	R0/W	SRC_RESYNC	1 = SRC will restart synchronisation	0
18	R	SRC_OUT_OK	SRC1_OUT Status 0: acquisition in progress 1: acquisition ready (In manual mode this bit is always 1)	0
17:16	R/W	SRC_OUT_US	SRC1_OUT UpSampling IIR filters setting 00: for sample rates up-to 48kHz 01: for sample rates of 96kHz 10: reserved 11: for sample rates of 192kHz	0
15	-	-	Reserved	0
14	R/W	SRC_OUT_CAL_BYPASS	SRC1_OUT1 upsampling filter bypass 0:Do not bypass 1:Bypass filter	0
13	R/W	SRC_OUT_AMODE	SRC1_OUT1 Automatic Conversion mode 0:Manual mode 1:Automatic mode	0
12	R/W	SRC_PDM_OUT_INV	Swap the left and the right output PDM channel	0
11	R/W	SRC_FIFO_DIRECTION	0 = SRC fifo is used to store samples from memory to SRC	0x0

Bit	Mode	Symbol	Description	Reset
			1 = SRC fifo is used to store sample from SRC to memory	
10	R/W	SRC_FIFO_ENABLE	0 = fifo disable. On each src request, one sample is serviced 1 = fifo enable. Fifo is used to store samples from / to src SRC supports only DMA burst size 4 when fifo is enable else no burst	0x0
9	R/W	SRC_OUT_DSD_MODE	0 = SRC1 OUT PDM mode 1 = SRC1 OUT DSD mode	0x0
8	R/W	SRC_IN_DSD_MODE	0: SRC1 IN PDM mode 1: SRC1 IN DSD mode	0x0
7	R/W	SRC_DITHER_DISABLE	Dithering feature 0: Enable 1: Disable	0
6	R	SRC_IN_OK	SRC1_IN status 0: Acquisition in progress 1: Acquisition ready	0
5:4	R/W	SRC_IN_DS	SRC1_IN UpSampling IIR filters setting 00: for sample rates up-to 48kHz 01: for sample rates of 96kHz 10: reserved 11: for sample rates of 192kHz	0
3	R/W	SRC_PDM_IN_INV	Swap the left and the right input PDM channel	0
2	R/W	SRC_IN_CAL_BYPASS	SRC1_IN upsampling filter bypass 0: Do not bypass 1: Bypass filter	0
1	R/W	SRC_IN_AMODE	SRC1_IN Automatic conversion mode 0: Manual mode 1: Automatic mode	0
0	R/W	SRC_EN	SRC1_IN and SRC1_OUT enable 0: disabled 1: enabled	0

Table 992: SRC1_IN_FS_REG (0x50030604)

Bit	Mode	Symbol	Description	Reset
31:24	-	-	Reserved	0
23:0	R/W	SRC_IN_FS	SRC_IN Sample rate $SRC_IN_FS = SRC_DIV * 4096 * Sample_rate / 100$ Sample_rate upper limit is 192kHz. For 96kHz and 192kHz SRC_CTRLx_REG[SRC_IN_DS] must be set as shown below: (for SRC_DIV=1) Sample_rate SRC_IN_FS SRC_IN_DS Audio bandwidth 8000 Hz 0x050000 0 4000 Hz	0

Bit	Mode	Symbol	Description	Reset
			<p>11025 Hz 0x06E400 0 5512 Hz 16000 Hz 0x0A0000 0 8000 Hz 22050 Hz 0x0DC800 0 11025 Hz 32000 Hz 0x140000 0 16000 Hz 44100 Hz 0x1B9000 0 22050 Hz 48000 Hz 0x1E0000 0 24000 Hz 96000 Hz 0x1E0000 1 24000 Hz 192000 Hz 0x1E0000 3 24000 Hz</p> <p>In manual SRC mode, SRC_IN_FS can be set and adjusted to the desired sample rate at any time. In automatic mode the SRC returns the final sample rate as soon as SRC_IN_OK. Note that SRC_DS is not calculated in automatic mode and must be set manually automatic mode with Sample_rate of 96 and 192kHz.</p>	

Table 993: SRC1_OUT_FS_REG (0x50030608)

Bit	Mode	Symbol	Description	Reset																																								
31:24	-	-	Reserved	0																																								
23:0	R/W	SRC_OUT_FS	<p>SRC_OUT Sample rate $SRC_OUT_FS = SRC_DIV * 4096 * Sample_rate / 100$ Sample_rate upper limit is 192kHz. For 96kHz and 192kHz SRC_CTRLx_REG[SRC_DS] must be set as shown below: (for SRC_DIV=1)</p> <table border="1"> <thead> <tr> <th>Sample_rate</th> <th>SRC_OUT_FS</th> <th>SRC_OUT_DS</th> <th>Audio bandwidth</th> </tr> </thead> <tbody> <tr> <td>8000 Hz</td> <td>0x050000</td> <td>0</td> <td>4000 Hz</td> </tr> <tr> <td>11025 Hz</td> <td>0x06E400</td> <td>0</td> <td>5512 Hz</td> </tr> <tr> <td>16000 Hz</td> <td>0x0A0000</td> <td>0</td> <td>8000 Hz</td> </tr> <tr> <td>22050 Hz</td> <td>0x0DC800</td> <td>0</td> <td>11025 Hz</td> </tr> <tr> <td>32000 Hz</td> <td>0x140000</td> <td>0</td> <td>16000 Hz</td> </tr> <tr> <td>44100 Hz</td> <td>0x1B9000</td> <td>0</td> <td>22050 Hz</td> </tr> <tr> <td>48000 Hz</td> <td>0x1E0000</td> <td>0</td> <td>24000 Hz</td> </tr> <tr> <td>96000 Hz</td> <td>0x1E0000</td> <td>1</td> <td>24000 Hz</td> </tr> <tr> <td>192000 Hz</td> <td>0x1E0000</td> <td>3</td> <td>24000 Hz</td> </tr> </tbody> </table> <p>In manual SRC mode, SRC_OUT_FS can be set and adjusted to the desired sample rate at any time. In automatic mode the SRC returns the final sample rate as soon as SRC_OUT_OK. Note that SRC_DS is not</p>	Sample_rate	SRC_OUT_FS	SRC_OUT_DS	Audio bandwidth	8000 Hz	0x050000	0	4000 Hz	11025 Hz	0x06E400	0	5512 Hz	16000 Hz	0x0A0000	0	8000 Hz	22050 Hz	0x0DC800	0	11025 Hz	32000 Hz	0x140000	0	16000 Hz	44100 Hz	0x1B9000	0	22050 Hz	48000 Hz	0x1E0000	0	24000 Hz	96000 Hz	0x1E0000	1	24000 Hz	192000 Hz	0x1E0000	3	24000 Hz	0
Sample_rate	SRC_OUT_FS	SRC_OUT_DS	Audio bandwidth																																									
8000 Hz	0x050000	0	4000 Hz																																									
11025 Hz	0x06E400	0	5512 Hz																																									
16000 Hz	0x0A0000	0	8000 Hz																																									
22050 Hz	0x0DC800	0	11025 Hz																																									
32000 Hz	0x140000	0	16000 Hz																																									
44100 Hz	0x1B9000	0	22050 Hz																																									
48000 Hz	0x1E0000	0	24000 Hz																																									
96000 Hz	0x1E0000	1	24000 Hz																																									
192000 Hz	0x1E0000	3	24000 Hz																																									

Bit	Mode	Symbol	Description	Reset
			calculated in automatic mode and must be set manually automatic mode with Sample_rate of 96 and 192kHz.	

Table 994: SRC1_IN1_REG (0x5003060C)

Bit	Mode	Symbol	Description	Reset
31:0	R/W	SRC_IN	SRC1_IN1	0

Table 995: SRC1_IN2_REG (0x50030610)

Bit	Mode	Symbol	Description	Reset
31:0	R/W	SRC_IN	SRC1_IN2	0

Table 996: SRC1_OUT1_REG (0x50030614)

Bit	Mode	Symbol	Description	Reset
31:0	R	SRC_OUT	SRC1_OUT1	0

Table 997: SRC1_OUT2_REG (0x50030618)

Bit	Mode	Symbol	Description	Reset
31:0	R	SRC_OUT	SRC1_OUT2	0

Table 998: APU_MUX_REG (0x5003061C)

Bit	Mode	Symbol	Description	Reset
6	R/W	PDM1_MUX_IN	PDM1 input mux 0 = SRC1_MUX_IN 1 = PDM input	0x0
5:3	R/W	PCM1_MUX_IN	PCM1 input mux 0 = off 1 = SRC1 output 2 = PCM output registers	0x0
2:0	R/W	SRC1_MUX_IN	SRC1 input mux 0 = off 1 = PCM output 2 = SRC1 input registers	0x0

Table 999: COEF10_SET1_REG (0x50030620)

Bit	Mode	Symbol	Description	Reset
31:16	R/W	SRC_COEF1	coefficient 1	0x79A9
15:0	R/W	SRC_COEF0	coefficient 0	0x9278

Table 1000: COEF32_SET1_REG (0x50030624)

Bit	Mode	Symbol	Description	Reset
31:16	R/W	SRC_COEF3	coefficient 3	0x6D56
15:0	R/W	SRC_COEF2	coefficient 2	0x8B41

Table 1001: COEF54_SET1_REG (0x50030628)

Bit	Mode	Symbol	Description	Reset
31:16	R/W	SRC_COEF5	coefficient 5	0x9BC5
15:0	R/W	SRC_COEF4	coefficient 4	0xBE15

Table 1002: COEF76_SET1_REG (0x5003062C)

Bit	Mode	Symbol	Description	Reset
31:16	R/W	SRC_COEF7	coefficient 7	0x8C28
15:0	R/W	SRC_COEF6	coefficient 6	0x7E1A

Table 1003: COEF98_SET1_REG (0x50030630)

Bit	Mode	Symbol	Description	Reset
31:16	R/W	SRC_COEF9	coefficient 9	0x92D7
15:0	R/W	SRC_COEF8	coefficient 8	0x75E6

Table 1004: COEF0A_SET1_REG (0x50030634)

Bit	Mode	Symbol	Description	Reset
15:0	R/W	SRC_COEF10	coefficient 10	0x41F2

Table 1005: PCM1_CTRL_REG (0x50030700)

Bit	Mode	Symbol	Description	Reset
31:20	R/W	PCM_FSC_DIV	PCM Framesync divider, Values 7-0xFFF. To divide by N, write N-1. (Minimum value N-1=7 for 8 bits PCM_FSC) Note if PCM_CLK_BIT=1, N must always be even	0x0
19:17	R	-	Reserved	0x0
16	R/W	PCM_FSC_EDGE	0: shift channels 1, 2, 3, 4, 5, 6, 7, 8 after PCM_FSC edge 1: shift channels 1, 2, 3, 4 after PCM_FSC edge shift channels 5, 6, 7, 8 after opposite PCM_FSC edge	0x0
15:11	R/W	PCM_CH_DEL	Channel delay in multiples of 8 bits	0x0
10	R/W	PCM_CLK_BIT	0:One clock cycle per data bit 1:Two cloc cycles per data bit	0x0
9	R/W	PCM_FSCINV	0: PCM FSC 1: PCM FSC inverted	0x0

Bit	Mode	Symbol	Description	Reset
8	R/W	PCM_CLKINV	0:PCM CLK 1:PCM CLK inverted	0x0
7	R/W	PCM_PPOD	0:PCM DO push pull 1:PCM DO open drain	0x0
6	R/W	PCM_FSCDEL	0:PCM FSC starts one cycle before MSB bit 1:PCM FSC starts at the same time as MSB bit	0x0
5:2	R/W	PCM_FSCLLEN	0:PCM FSC length equal to 1 data bit N:PCM FSC length equal to N*8	0x0
1	R/W	PCM_MASTER	0:PCM interface in slave mode 1:PCM interface in master mode	0x0
0	R/W	PCM_EN	0:PCM interface disabled 1:PCM interface enabled	0x0

Table 1006: **PCM1_IN1_REG** (0x50030704)

Bit	Mode	Symbol	Description	Reset
31:0	R	PCM_IN	PCM1_IN1 bits 31-0	0x0

Table 1007: **PCM1_IN2_REG** (0x50030708)

Bit	Mode	Symbol	Description	Reset
31:0	R	PCM_IN	PCM1_IN2 bits 31-0	0x0

Table 1008: **PCM1_OUT1_REG** (0x5003070C)

Bit	Mode	Symbol	Description	Reset
31:0	R/W	PCM_OUT	PCM1_OUT1 bits 31-0	0xFFFFFFFF FFF

Table 1009: **PCM1_OUT2_REG** (0x50030710)

Bit	Mode	Symbol	Description	Reset
31:0	R/W	PCM_OUT	PCM1_OUT2 bits 31-0	0xFFFFFFFF FFF

42.32 Analog Miscellaneous Registers

Table 1010: Register map ANAMISC

Address	Register	Description
0x50030B10	CLK_REF_SEL_REG	Select clock for oscillator calibration
0x50030B14	CLK_REF_CNT_REG	Count value for oscillator calibration
0x50030B18	CLK_REF_VAL_REG	DIVN reference cycles, lower 16 bits

Table 1011: **CLK_REF_SEL_REG** (0x50030B10)

Bit	Mode	Symbol	Description	Reset
7:5	R/W	CAL_CLK_SEL	Select reference clock input to be used in calibration: 0x0 : DIVN clock 0x1 : RC32K 0x2 : RC32M 0x3 : XTAL32K 0x4 : RCOSC 0x5, 0x6, 0x7: Reserved	0x0
4	R/W	EXT_CNT_EN_SEL	0 : Enable XTAL_CNT counter by the REF_CLK selected by REF_CLK_SEL. 1 : Enable XTAL_CNT counter from an external input.	0x0
3	R/W	REF_CAL_START	Writing a '1' starts a calibration. This bit is cleared when calibration is finished, and CLK_REF_VAL is ready.	0x0
2:0	R/W	REF_CLK_SEL	Select clock input for calibration: 0x0 : RC32K 0x1 : RC32M 0x2 : XTAL32K 0x3 : RCX 0x4 : RCOSC	0x0

Table 1012: **CLK_REF_CNT_REG** (0x50030B14)

Bit	Mode	Symbol	Description	Reset
15:0	R/W	REF_CNT_VAL	Indicates the calibration time, with a decrement counter to 1.	0x0

Table 1013: **CLK_REF_VAL_REG** (0x50030B18)

Bit	Mode	Symbol	Description	Reset
31:0	R	XTAL_CNT_VAL	Returns the number of DIVN clock cycles counted during the calibration time, defined with REF_CNT_VAL	0x0

42.33 Crypto-Engine Registers

Table 1014: Register map AES_HASH

Address	Register	Description
0x30040000	CRYPTO_CTRL_REG	Crypto Control register
0x30040004	CRYPTO_START_REG	Crypto Start calculation
0x30040008	CRYPTO_FETCH_ADDR_REG	Crypto DMA fetch register
0x3004000C	CRYPTO_LEN_REG	Crypto Length of the input block in bytes
0x30040010	CRYPTO_DEST_ADDR_REG	Crypto DMA destination memory
0x30040014	CRYPTO_STATUS_REG	Crypto Status register

Address	Register	Description
0x30040018	CRYPTO_CLRIRQ_REG	Crypto Clear interrupt request
0x3004001C	CRYPTO_MREG0_REG	Crypto Mode depended register 0
0x30040020	CRYPTO_MREG1_REG	Crypto Mode depended register 1
0x30040024	CRYPTO_MREG2_REG	Crypto Mode depended register 2
0x30040028	CRYPTO_MREG3_REG	Crypto Mode depended register 3
0x30040100	CRYPTO_KEYS_START	Crypto First position of the AES keys storage memory

Table 1015: CRYPTO_CTRL_REG (0x30040000)

Bit	Mode	Symbol	Description	Reset
17	R/W	CRYPTO_AES_KEXP	It forces (active high) the execution of the key expansion process with the starting of the AES encryption/decryption process. The bit will be cleared automatically by the hardware, after the completion of the AES key expansion process.	0x0
16	R/W	CRYPTO_MORE_IN	0 : Define that this is the last input block. When the current input is consumed by the crypto engine and the output data is written to the memory, the calculation ends (CRYPTO_INACTIVE goes to one). 1 : The current input data block is not the last. More input data will follow. When the current input is consumed, the engine stops and waits for more data (CRYPTO_WAIT_FOR_IN goes to one).	0x0
15:10	R/W	CRYPTO_HASH_OUT_LEN	The number of bytes minus one of the hash result which will be saved at the memory by the DMA. In relation with the selected hash algorithm the accepted values are: MD5: 0..15 -> 1-16 bytes SHA-1: 0..19 -> 1-20 bytes SHA-256: 0..31 -> 1 - 32 bytes SHA-256/224: 0..27 -> 1- 28 bytes SHA-384: 0..47 -> 1 - 48 bytes SHA-512: 0..63 -> 1 - 64 bytes SHA-512/224: 0..27 -> 1- 28 bytes SHA-512/256: 0..31 -> 1 - 32 bytes	0x0
9	R/W	CRYPTO_HASH_SEL	Selects the type of the algorithm 0 : The encryption algorithm (AES) 1 : A hash algorithm. The exact algorithm is defined by the fields CRYPTO_ALG and CRYPTO_ALG_MD.	0x0
8	R/W	CRYPTO_IRQ_EN	Interrupt Request Enable 0 : The interrupt generation ability is disabled. 1 : The interrupt generation ability is enabled. Generates an interrupt request at the end of operation.	0x0
7	R/W	CRYPTO_ENCDEC	Encryption/Decryption 0 : Decryption 1 : Encryption	0x0
6:5	R/W	CRYPTO_AES_KEY_SZ	The size of AES Key 0x0 : 128 bits AES Key 0x1 : 192 bits AES Key	0x0

Bit	Mode	Symbol	Description	Reset
			0x2 : 256 bits AES Key 0x3 : 256 bits AES Key	
4	R/W	CRYPTO_OUT_MD	Output Mode. This field makes sense only when the AES algorithm is selected (CRYPTO_HASH_SEL = 0) 0 : Write back to memory all the resulting data 1 : Write back to memory only the final block of the resulting data	0x0
3:2	R/W	CRYPTO_ALG_MD	It defines the mode of operation of the AES algorithm when the controller is configured for an encryption/decryption processing (CRYPTO_HASH_SEL = 0). 0x0 : ECB 0x1 : ECB 0x2 : CTR 0x3 : CBC When the controller is configured to applies a HASH function, this field selects the desired HASH algorithm with the help of the CRYPTO_ALG. 0x0 : HASH algorithms that are based on 32 bits operations 0x1 : HASH algorithms that are based on 64 bits operations 0x2 : Reserved 0x3 : Reserved See also the CRYPTO_ALG field.	0x0
1:0	R/W	CRYPTO_ALG	Algorithm selection. When CRYPTO_HASH_SEL = 0 the only available choice is the AES algorithm. 0x0 : AES 0x1 : Reserved 0x2 : Reserved 0x3 : Reserved When CRYPTO_HASH_SEL = 1, this field selects the desired hash algorithm, with the help of the CRYPTO_ALG_MD field. If CRYPTO_ALG_MD = 0x0 0x0 : MD5 0x1 : SHA-1 0x2 : SHA-256/224 0x3 : SHA-256 If CRYPTO_ALG_MD = 0x1 0x0 : SHA-384 0x1 : SHA-512 0x2 : SHA-512/224 0x3 : SHA-512/256	0x0

Bit	Mode	Symbol	Description	Reset

Table 1016: **CRYPTO_START_REG (0x30040004)**

Bit	Mode	Symbol	Description	Reset
0	R0/W	CRYPTO_START	Write 1 to initiate the processing of the input data. This register is auto-cleared.	0x0

Table 1017: **CRYPTO_FETCH_ADDR_REG (0x30040008)**

Bit	Mode	Symbol	Description	Reset
31:0	R/W	CRYPTO_FETCH_ADDR	The memory address from where will be retrieved the data that will be processed. The value of this register is updated as the calculation proceeds and the output data are written to the memory.	0x0

Table 1018: **CRYPTO_LEN_REG (0x3004000C)**

Bit	Mode	Symbol	Description	Reset
23:0	R/W	CRYPTO_LEN	It contains the number of bytes of input data. If this number is not a multiple of a block size, the data is automatically extended with zeros. The value of this register is updated as the calculation proceeds and the output data are written to the memory.	0x0

Table 1019: **CRYPTO_DEST_ADDR_REG (0x30040010)**

Bit	Mode	Symbol	Description	Reset
31:0	R/W	CRYPTO_DEST_ADDR	Destination address at where the result of the processing is stored. The value of this register is updated as the calculation proceeds and the output data are written to the memory.	0x0

Table 1020: **CRYPTO_STATUS_REG (0x30040014)**

Bit	Mode	Symbol	Description	Reset
2	R	CRYPTO_IRQ_ST	The status of the interrupt request line of the CRYPTO block. 0 : There is no active interrupt request. 1 : An interrupt request is pending.	0x0
1	R	CRYPTO_WAIT_FOR_IN	Indicates the situation where the engine waits for more input data. This is applicable when the CRYPTO_MORE_IN= 1, so the input data are fragmented in the memory. 0 : The crypto is not waiting for more input data. 1 : The crypto waits for more input data. The CRYPTO_INACTIVE flag remains to zero to indicate that the calculation is not finished. The supervisor of the CRYPTO must program to the CRYPTO_FETCH_ADDR and CRYPTO_LEN a new input data fragment. The calculation will be continued as soon as the CRYPTO_START register will be written	0x0

Bit	Mode	Symbol	Description	Reset
			with 1. This action will clear the CRYPTO_WAIT_FOR_IN flag.	
0	R	CRYPTO_INACTIVE	0 : The CRYPTO is active. The processing is in progress. 1 : The CRYPTO is inactive. The processing has finished.	0x1

Table 1021: CRYPTO_CLRIRQ_REG (0x30040018)

Bit	Mode	Symbol	Description	Reset
0	R0/W	CRYPTO_CLRIRQ	Write 1 to clear a pending interrupt request.	0x0

Table 1022: CRYPTO_MREG0_REG (0x3004001C)

Bit	Mode	Symbol	Description	Reset
31:0	R/W	CRYPTO_MREG0	It contains information that are depended by the mode of operation, when is used the AES algorithm: CBC - IV[31:0] CTR - CTRBLK[31:0]. It is the initial value of the 32 bits counter. At any other mode, the contents of this register has no meaning.	0x0

Table 1023: CRYPTO_MREG1_REG (0x30040020)

Bit	Mode	Symbol	Description	Reset
31:0	R/W	CRYPTO_MREG1	It contains information that are depended by the mode of operation, when is used the AES algorithm: CBC - IV[63:32] CTR - CTRBLK[63:32] At any other mode, the contents of this register has no meaning.	0x0

Table 1024: CRYPTO_MREG2_REG (0x30040024)

Bit	Mode	Symbol	Description	Reset
31:0	R/W	CRYPTO_MREG2	It contains information that are depended by the mode of operation, when is used the AES algorithm: CBC - IV[95:64] CTR - CTRBLK[95:64] At any other mode, the contents of this register has no meaning.	0x0

Table 1025: CRYPTO_MREG3_REG (0x30040028)

Bit	Mode	Symbol	Description	Reset
31:0	R/W	CRYPTO_MREG3	It contains information that are depended by the mode of operation, when is used the AES algorithm: CBC - IV[127:96] CTR - CTRBLK[127:96] At any other mode, the contents of this register has no meaning.	0x0

Table 1026: CRYPTO_KEYS_START (0x30040100)

Bit	Mode	Symbol	Description	Reset
31:0	W	CRYPTO_KEY_X	CRYPTO_KEY_(0-63) This is the AES keys storage memory. This memory is accessible via AHB slave interface, only when the CRYPTO is inactive (CRYPTO_INACTIVE = 1).	N/A

43. Ordering Information

Table 1027: Ordering information (samples/production)

Part number	Package	Size (mm)	Shipment form	Pack quantity
DA14691-00000HQ2	VFBGA86	6 x 6 x 0.9	Reel	100/1000 (samples) 4000 (production)
DA14695-00000HQ2	VFBGA86	6 x 6 x 0.9	Reel	100/1000 (samples) 4000 (production)
DA14697-00000HR2	VFBGA100	5 x 5 x 0.9	Reel	100/1000 (samples) 5000 (production)
DA14699-00000HR2	VFBGA100	5 x 5 x 0.9	Reel	100/1000 (samples) 5000 (production)

Table 1028: Ordering information (custom)

Part number	Package	Size (mm)	Shipment form	Pack quantity
DA14697-10000HR2	VFBGA100	5 x 5 x 0.9	Reel	5000

Part Number Legend:

DA1469x-RRXXYYZ

RR: chip revision number

XXX: variant (00T: High Temperature)

YY: package code (HQ: VFBGA86, HR: VFBGA100)

Z: packing method (1: Tray, 2: Reel, A: Mini-Reel)

44. Package Information

44.1 Moisture Sensitivity Level (MSL)

The MSL is an indicator for the maximum allowable time period (floor lifetime) in which a moisture sensitive plastic device, once removed from the dry bag, can be exposed to an environment with a maximum temperature of 30 °C and a maximum relative humidity of 60 % RH before the solder reflow process.

BGA packages are qualified for MSL 3.

MSL level	Floor lifetime
MSL 4	72 hours
MSL 3	168 hours
MSL 2A	4 weeks
MSL 2	1 year
MSL 1	Unlimited at 30 °C/85 % RH

44.2 Soldering Information

Refer to the JEDEC standard J-STD-020 for relevant soldering information. This document can be downloaded from <http://www.jedec.org>.

44.3 Package Outlines

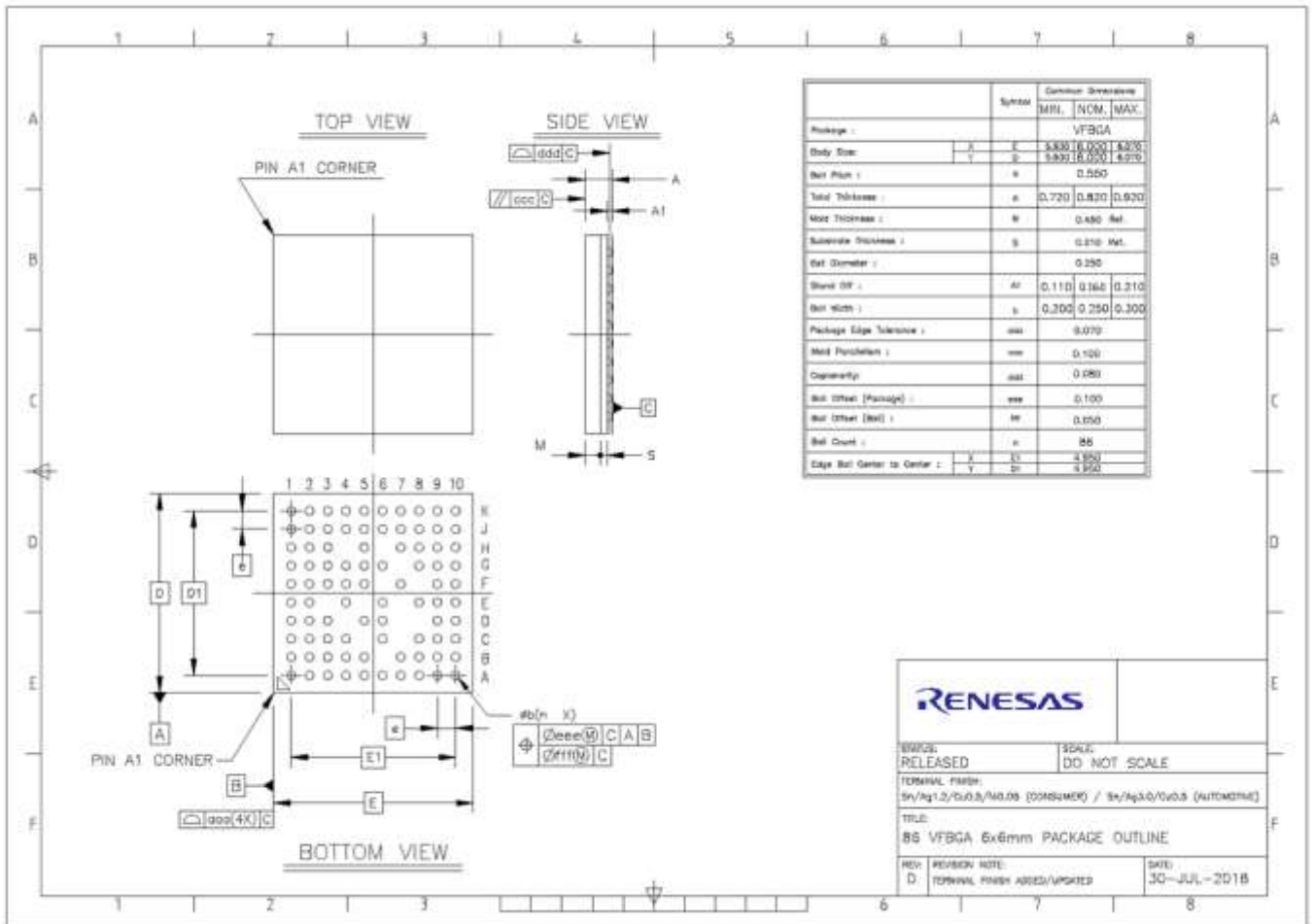

Figure 112. VFBGA86 Package outline drawing

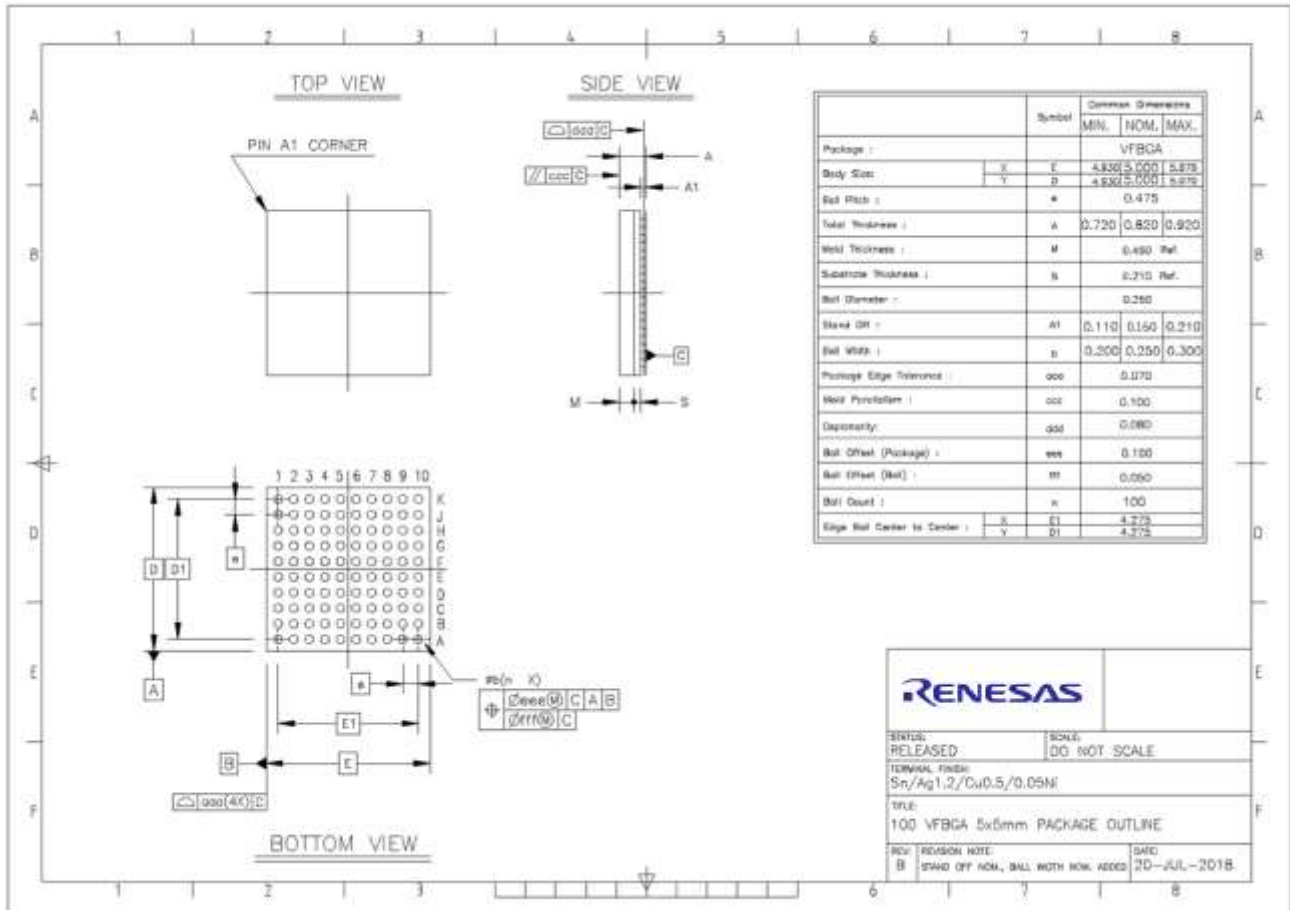

Figure 113. VFPGA100 Package outline drawing

45. Revision History

Revision	Date	Description
3.4	Apr 10, 2025	Converted into Renesas template.
3.3	Apr 22, 2022	<ul style="list-style-type: none"> ▪ Updated logo, disclaimer, copyright ▪ Section 27.2.11.2 Corrected the difftemp conversion function ▪ Section 37.2.3 Corrected USB_NFSR_REG ▪ Updated the description of RC32K ▪ Updated the following tables: <ul style="list-style-type: none"> • DC-DC Converter Characteristics (Table 6) • General Purpose ADC Characteristics (Table 13, Table 18) • Bandgap Characteristics (Table 10) • LDOs Characteristics (Table 20, Table 21, Table 32, Table 38) • RCX Oscillator Characteristics (Table 43) • LRA Characteristics (Table 56) • Battery Check Characteristics (Table 48) ▪ Register description typos and text corrections ▪ Removed references to WLEDs ▪ Removed the LDO_RADIO tables (Table 33, Table 34, Table 35)
3.2	Oct 12, 2020	<ul style="list-style-type: none"> ▪ Editorial corrections ▪ Corrected table 138 ▪ Corrected chapter 7.2.7 (primary charger detection) values ▪ Added rail discharging section in Charger chapter ▪ Updated GPIOs being CMAC SWD pins by default in IO chapter ▪ Added GPADC LDO dependency to V18P ▪ Added DCDC V12/V14 rail characteristics ▪ Added typical value for pin leakage in characteristics
3.1	Oct 18, 2019	<ul style="list-style-type: none"> ▪ Editorial corrections sections 40.2.5 ▪ Added new legal text to section 38.4 ▪ Section 10.2, Table 88, following regs removed (RTC_EVENT_CTRL_REG, RTC_MOTOR_EVENT_PERIOD_REG, RTC_PDC_EVENT_PERIOD_REG) ▪ Table 699 P0_PADPWR_CTRL_REG (0x50020AF4), added text "1.8 V only" to description ▪ Corrected Figure 57: Wake-up Controller Block Diagram ▪ Sections 6.3.3 Wake-up Options, Ultra-Fast (The VDD_SLEEP_LEVEL voltage must be 0.9 V) ▪ Section 15.2.1 removed brackets from (Operand2)
3.0	July 26, 2019	Product status: Final. Datasheet status: Final.
Change details: Specifications updated, JIRA items added, text and graphics edited, disclaimer updated.		
2.0	Apr 20, 2019	Product status: Preliminary. Datasheet status: Qualification.

RoHS Compliance

Renesas Electronics' suppliers certify that its products are in compliance with the requirements of Directive 2011/65/EU of the European Parliament on the restriction of the use of certain hazardous substances in electrical and electronic equipment. RoHS certificates from our suppliers are available on request.

IMPORTANT NOTICE AND DISCLAIMER

RENESAS ELECTRONICS CORPORATION AND ITS SUBSIDIARIES (“RENESAS”) PROVIDES TECHNICAL SPECIFICATIONS AND RELIABILITY DATA (INCLUDING DATASHEETS), DESIGN RESOURCES (INCLUDING REFERENCE DESIGNS), APPLICATION OR OTHER DESIGN ADVICE, WEB TOOLS, SAFETY INFORMATION, AND OTHER RESOURCES “AS IS” AND WITH ALL FAULTS, AND DISCLAIMS ALL WARRANTIES, EXPRESS OR IMPLIED, INCLUDING, WITHOUT LIMITATION, ANY IMPLIED WARRANTIES OF MERCHANTABILITY, FITNESS FOR A PARTICULAR PURPOSE, OR NON-INFRINGEMENT OF THIRD-PARTY INTELLECTUAL PROPERTY RIGHTS.

These resources are intended for developers who are designing with Renesas products. You are solely responsible for (1) selecting the appropriate products for your application, (2) designing, validating, and testing your application, and (3) ensuring your application meets applicable standards, and any other safety, security, or other requirements. These resources are subject to change without notice. Renesas grants you permission to use these resources only to develop an application that uses Renesas products. Other reproduction or use of these resources is strictly prohibited. No license is granted to any other Renesas intellectual property or to any third-party intellectual property. Renesas disclaims responsibility for, and you will fully indemnify Renesas and its representatives against, any claims, damages, costs, losses, or liabilities arising from your use of these resources. Renesas' products are provided only subject to Renesas' Terms and Conditions of Sale or other applicable terms agreed to in writing. No use of any Renesas resources expands or otherwise alters any applicable warranties or warranty disclaimers for these products.

(Disclaimer Rev.1.01 Jan 2024)

Corporate Headquarters

TOYOSU FORESIA, 3-2-24 Toyosu
Koto-ku, Tokyo 135-0061, Japan

www.renesas.com

Trademarks

Renesas and the Renesas logo are trademarks of Renesas Electronics Corporation. All trademarks and registered trademarks are the property of their respective owners.

Contact Information

For further information on a product, technology, the most up-to-date version of a document, or your nearest sales office, please visit www.renesas.com/contact-us

© 2025 Renesas Electronics Corporation. All rights reserved.