

## HJ-131IMH

Ultra-small chip level (4mm \* 4mm, include ANT) ,ultra low power

Bluetooth 5.1 module DataSheet

**DataSheet version: V1.7**



Model : **HJ-131IMH**



Size: 4mm\*4mm\*1.3mm

# CATALOG

1、 Version History.....	- 1 -
2、 Overview.....	- 2 -
2.1 Characteristics.....	- 2 -
3、 Hardware specification.....	- 4 -
3.1 Package and dimensions.....	- 4 -
3.2 Pin Definition.....	- 5 -
3.3 Internal Structure.....	- 7 -
3.4 Reference Design.....	- 7 -
3.4.1 Low Voltage Mode (Can be powered by one single AA size battery, voltage range: 1.1-1.65V).....	- 7 -
3.4.2 HighVoltage Mode (Voltage range: 1.8-3.6V).....	- 8 -
3.4.3 Using the built-in antenna of the module.....	- 8 -
3.4.4 Using an external antenna.....	- 8 -
3.4.5 Notice for Hardware Design.....	- 8 -
3.4.6 Matters needing attention in the use of products.....	- 9 -
4、 Electrical Parameters.....	- 10 -
4.1 Absolute Maximum Range.....	- 10 -
4.2 Recommended Operating Conditions.....	- 10 -
4.3 I/O DC Characteristics.....	- 10 -
4.4 RF Features.....	- 11 -
4.5 Power Dissipation.....	- 11 -
5、 Reflow Soldering Information.....	- 12 -
6、 Notices for Ultrasound Welding.....	- 13 -
7、 Supply Information.....	- 14 -
7.1 Model Definition.....	- 14 -
7.2 Development Kit Board.....	- 15 -
7.3 Packaging method.....	- 15 -

## 1、Version History

Table 1-1 Revision History

No.	Version Number	Release Time	Reviser	Checker	Description
1	V1.2	20191109	LMY	LJH	First edition
2	V1.31	20200101	LMY	ZYP	Update Parameters
3	V1.5	20200206	LMY	LJH	Redefine pin functions
4	V1.7	20200512	LMY	ZYP	Add Development Kit board

## 2、 Overview

### 2.1 Characteristics

- Supply voltage range: High Voltage Mode 1.8V~3.6V;Low Voltage Mode 1.1V~1.65V
- It can be powered by a single AA size battery or a zinc air battery at 1.5V. After voltage regulation,it can also be powered by 2 pcs AA size batteries or lithium cells.
- GPIO max: 6
- 4mm \* 4mm volume includes built-in high-performance antenna(External antenna can also be used)
  
- Memories
  - 32KB of OTP
  - 48KB of RAM
  - 4KB of EEPROM
- External 512Kb EEPROM or 1Mb EEPROM can be used to store user programs and OTA
  
- Functions
  - Support BLE 5.1, embedded low energy Bluetooth protocol stack and GATT service
  - Support BLE master-slave integration (Support 1 slave 1 master or 3 slaves, master and slave work at the same time without affecting each other)
  - Built-in standard firmware supports 1 slave, supports multiple instructions to configure BLE module(Refer to "HJ-131IMH Built-in Firmware Software Function Document")
  - Built-in standard firmware supports transparent transmission,support WeChat, or no program module for customers to develop firmware by themselves
  
- RF Features
  - Operating Frequency: 2.4GHz, Support ISM free Frequency band
  - Transmitting Power: -19.5dBm ~ +2.5dBm
  - Receiver sensitivity: -94dBm
  - TX peak current < 3.5mA ; RX peak current < 2.2mA
  - When using the On-board antenna in an open area, the transmission distance of wireless signal can spread more than 5 metres and less than 10 metres.
  - When using an external antenna in an open area, the transmission distance of wireless signal can

spread more than 40 metres and less than 80 metres.

●Low Power Dissipation

- Sleep current < 2 $\mu$ A
- One second broadcast current: 7 $\mu$ A(0dBm)
- Two second broadcast current: 3.8 $\mu$ A(0dBm)
- 20ms connection gap current 65 $\mu$ A (0dBm)
- 1000ms connection gap current 6.8 $\mu$ A(0dBm)

●Applications

- Tiny medical applications
- Beacons
- Smart toys
- Smart locks
- Remote controls
- Industrial smart devices

●Package: LGA17, pad spacing: 0.8mm, pad size:0.5\*0.5mm

●Size: 4mm\*4mm\*1.3mm(Built-in antenna inside)

●Weight: 0.5g

●Operating temperature range: -40 ~ +85°C(Maximum temperature up to +120°C)

●BQB FCC CE KC SRRC REACH RoHS compliant

### 3、 Hardware specification

#### 3.1 Package and dimensions

The package of HJ-1311MH is LGA17, welding pad spacing is 0.8 mm. Detailed dimensions are shown in the figure 3-1, 3-2, 3-3, 3-4.

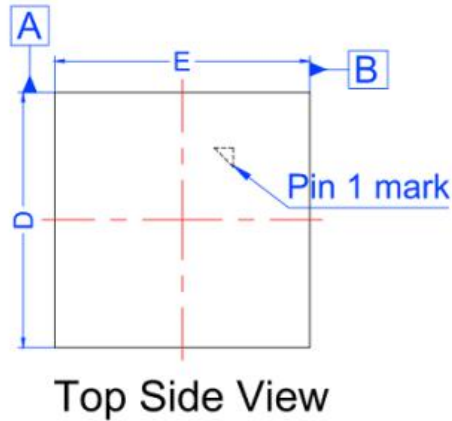

Figure 3-1 Top view

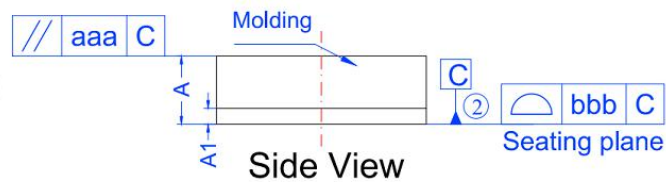

Figure 3-2 Side view

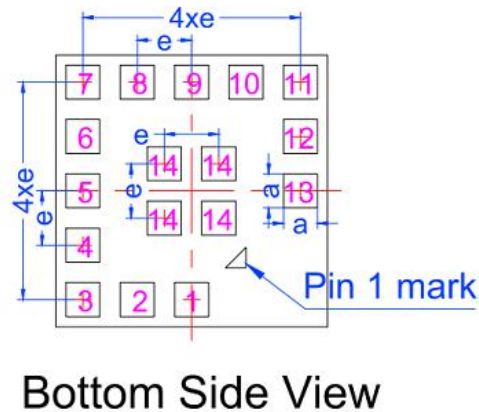

Figure 3-3 Bottom view

*DIMENSIONAL REFERENCES Units:mm*

SYMBOL	DIMENSIONAL REQMTS			SYMBOL	Tolerance of Form & Position
	MIN	NOM	MAX		
A	1.26	1.30	1.34	aaa	0.10
A1	0.27	0.30	0.33	bbb	0.10
D	3.90	4.00	4.10		
E	3.90	4.00	4.10		
a	0.45	0.50	0.55		
e	0.80 REF				

Note:

1. All dimensions are in mm
- ② Datum 'C' is the mounting surface, with which the package is in contact

Figure 3-4 Dimensions picture

### 3.2 Pin Definition

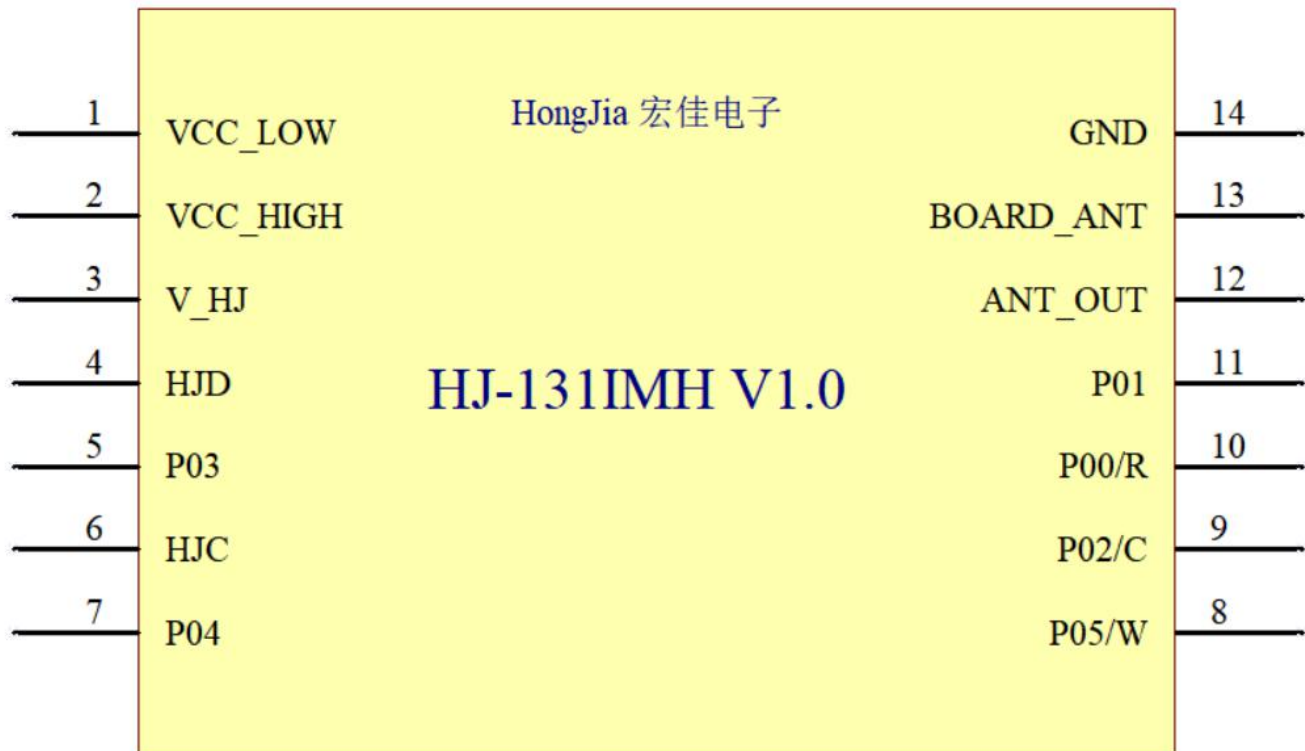

Table 3-1 Pin definition table

Pin	Name	Type	Description	(customized / transparent transmission) function
1	VCC_LOW	Low Power In	Low voltage power input port	Low Voltage Mode input : 1.1-1.65V
2	VCC_HIGH	High Power In	High voltage power input port	High Voltage Mode input : 1.8-3.6V
3	<i>V_HJ</i>	<i>HongJia Reserve</i>	<i>Internal EEPROM power supply pin</i>	<i>Power supply range 1.7-3.6V, please connect with VCC_HIGH if needed</i>
4	<i>HJD</i>	<i>HongJia Reserve</i>	<i>Internal EEPROM SDA pin</i>	<i>If needed, please connect with P03</i>
5	P03	IO	General purposed GPIO	If you need to use internal EEPROM, please connect with HJD
6	<i>HJC</i>	<i>HongJia Reserve</i>	<i>Internal EEPROM SCL pin</i>	<i>If needed, please connect with P04</i>
7	P04	IO	General purposed GPIO	If you need to use internal EEPROM, please connect with HJC
8	P05/W	UART TX	General purposed GPIO	BLE serial prot's TX pin
9	P02/C	WAKEUP/UART RX	Wake-up Pin / UART Pin	Wake-up function and BLE serial RX (Under low power consumption, the pin defaults to the wake-up pin. If the external high level is increased for more than 1ms, BLE can be woken up. After waking up, this pin becomes the UART RX function, which can perform normal data transmission and reception;)
10	P00/R	I/RST	Reset Pin	High-level reset; floating or low-level normal operation
11	P01	O	Connection Status Pin	Connection status (connection = 1; disconnect = 0)
12	ANT_OUT	RF OUT	RF Output	RF output, can be used with external antenna
13	BOARD_ANT	Onboard ANT	Onboard antenna input port	Internal integrated matching circuit. If an internal antenna is used, short circuit the 12 and 13 pins directly.
14	GND	Ground	Power Input GND	Power Negative GND



### 3.3 Internal Structure

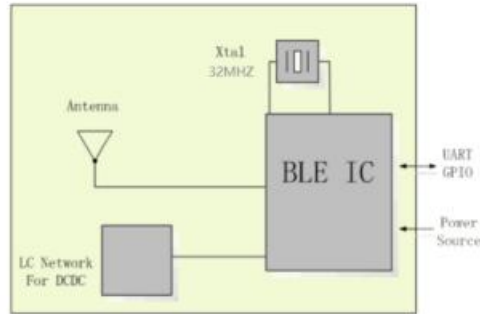

Figure 3-5 HJ-1311MH internal structure frame

### 3.4 Reference Design

#### 3.4.1 Low Voltage Mode (Can be powered by one single AA size battery, voltage range: 1.1-1.65V)

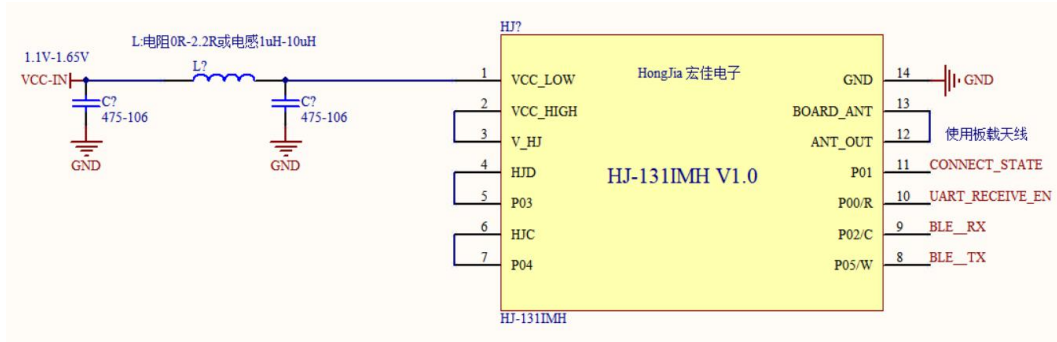

Figure 3-6 Low Voltage Supply Mode

### 3.4.2 High Voltage Mode (Voltage range: 1.8-3.6V)

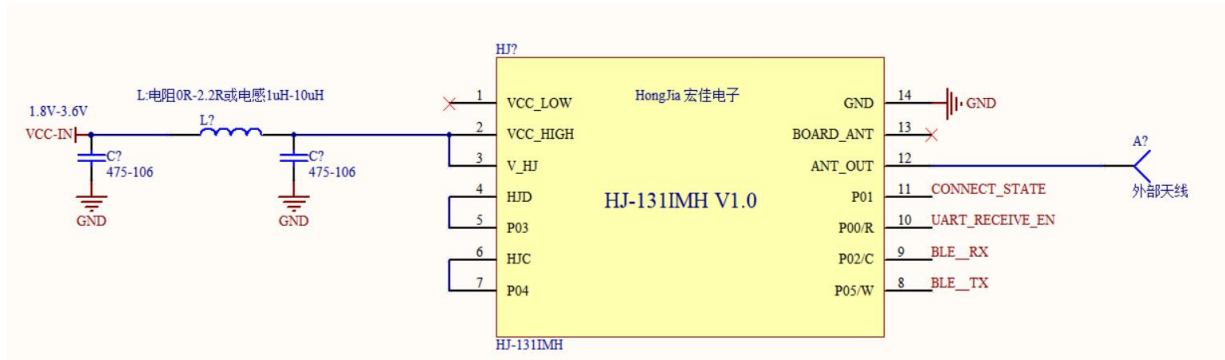
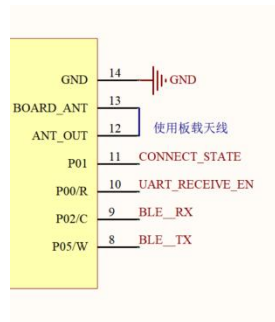
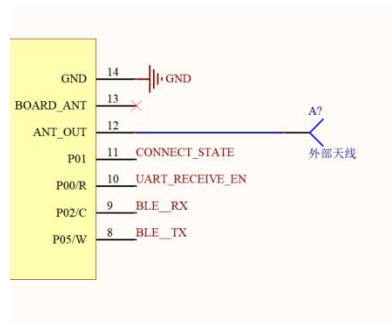

Figure 3-7 High Voltage Supply Mode

### 3.4.3 Using the built-in antenna of the module



### 3.4.4 Using an external antenna



### 3.4.5 Notice for Hardware Design

A. All I/Os can be used.

B. PI filter is added to the power input. L? Can choose resistance or inductance. If the space is limited, it can also be omitted, and a 475-106 ceramic capacitor in 0603 package or 0402 package can be directly connected in parallel.

C. The TP? is the test points, if necessary, add it.

TangShan HongJia Electronic Technology Co., Ltd.

<http://www.tshjdz.com>

C. When using an external antenna, be sure to contact us to let us confirm whether your external PCB antenna or IPEX lead-out antenna PCB design is reasonable.

### **3.4.6 Matters needing attention in the use of products**

A. The module should not be placed in a metal-based enclosure. If a metal enclosure is required, the antenna must be lead out.

B. Among the products that need to install this wireless module, some metal materials such as screws, inductors, etc. should be kept away from the RF antenna part of the wireless module.

C. On the wireless module antenna, Do not place other components. Because other components can degrade wireless performance.

D. Place the wireless module on the peripheral edge of the motherboard as much as possible. The antenna part should be close to the side or corner of the motherboard. The motherboard PCB under the module antenna should be hollowed out with the keepout layer. If hollowing is prohibited, copper or wiring is not allowed under the antenna. Otherwise it will affect RF performance.

E. Please pay attention to the pin diagram for all pins. Please pay attention to the IO mode and status of the IO connected to it.

F. GND must be sound grounding.

G. It is recommended that magnetic beads or inductance filters be applied to the input power supply.

## 4、Electrical Parameters

### 4.1 Absolute Maximum Range

Table 4-1 Absolute maximum ratings

Parameter	MIN	MAX	Unit
Power Supply Voltage (VCC)	1.05	3.7	V
IO Supply Voltage	0	VCC	V
Operating Temperature	-45	+120	°C
Storage Temperature	-55	+135	°C

### 4.2 Recommended Operating Conditions

Table 4-2 Recommended operating conditions

Parameter	MIN	TYP	MAX	Unit
Power Supply Voltage (VCC)	1.8(1.05)	3.3(1.5)	3.6(1.8)	V
IO Supply Voltage	0	3.3(1.8)	VCC	V
Dormant working current		<2		μA
Maximum Operating Current		5		mA
Operating Temperature	-40	+25	+85	°C

### 4.3 I/O DC Characteristics

Table 4-3 I/O DC Characteristics

I/O Pin	Driving Capability	MIN	MAX	Unit
Input low voltage		0	0.4	V
Input high voltage		0.7	VCC	V
Output low voltage	5mA	0	0.6	V
Output high voltage	5mA	3.3	VCC	V

## 4.4 RF Features

Table 4-4 RF Features

Attribute	Value	Remarks
Modulation	GFSK	
Frequency range	2.402 ~ 2.480Ghz	Bandwidth: 2Mhz
Number of channels	40	
Air speed	1Mbps	
RF Port Impedance	50Ω	
Transmit Power	MAX: +2.5dbm	
TX Current consumption	TYP: 3.5mA	
RX Current consumption	TYP: 2.2mA	
Receive sensitivity	TYP: -94dbm, MAX: -95dbm	
Antenna	Onboard PCB Antenna	External antenna can be used

## 4.5 Power Dissipation

Table 4-5 Power Dissipation

Test conditions	TYP	Unit
Dormancy mode	<2	μA
20ms Interval Broadcasting in Slave Mode	180	μA
1S Interval Broadcasting in Slave Mode	7.0	μA
20ms Connection Gap Holding Connection in Slave Mode	65	μA
7.5ms Connection Gap Holding Connection in Slave Mode	110	μA
Scanning in Host Mode	2.3	mA
20ms Connection Gap Holding Connection in Host Mode	78	μA

## 5、 Reflow Soldering Information

Reflow soldering is recommended for welding.

HJ-131IMH module use high temperature resistant materials, manufacturing by Lead-free Process. The maximum temperature resistance is 265°C. Ten continuous reflow soldering has no effect on properties and strength. Specific parameters as shown in Table 5-1.

Table 5-1 Reflow soldering parameters

Parameter	Value
Features	Lead-free process
Average ramp up rate( $T_{S\text{MAX}}$ to $T_p$ )	3°C/sec. max
Temperature Min( $T_{S\text{min}}$ )	150°C
Temperature Max( $T_{S\text{max}}$ )	200°C
Preheat time (Min to Max) ( $t_s$ )	80~100sec.
Peak Temperature ( $T_p$ )	250±5°C
Ramp-down Rate	6°C/sec. max
Time 25°C to Peak Temp ( $T_p$ )	8 min. max

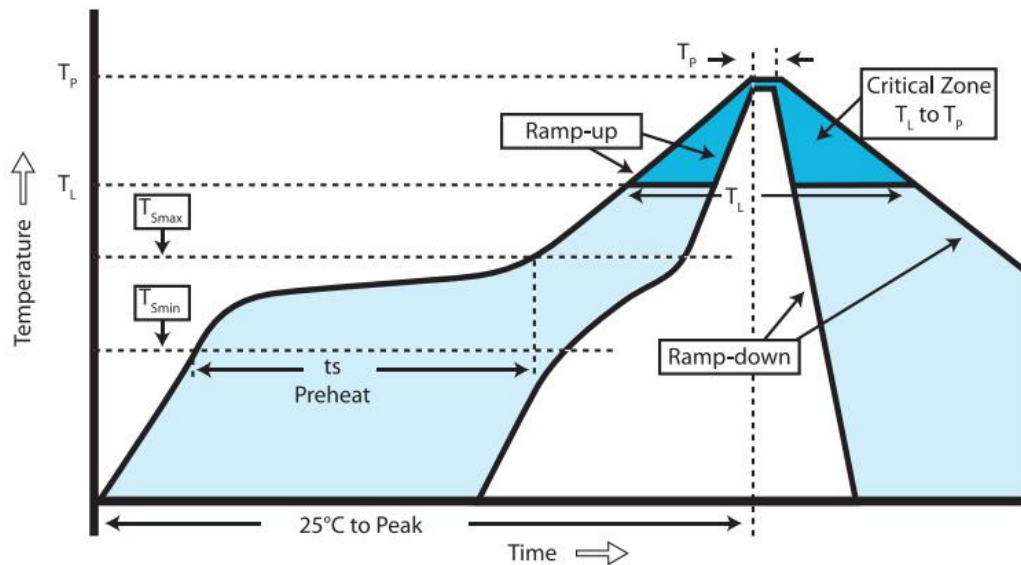

Figure 5-1 Temperature Curve of Reflow Welding

## 6、 Notices for Ultrasound Welding

**Warning:** Please carefully consider using ultrasonic welding technology. If it is necessary to use ultrasonic welding technology, please use 40KHz high frequency ultrasound welding technology. Keep the module away from the ultrasonic soldering line and the fixing column during the design method to prevent damage to the module!

For specific ultrasonic welding matters, please contact our company for technical consultation.

## 7、 Supply Information

### 7.1 Model Definition

Table 7-1 Model Definition

Type	Model	Description
Standard Edition of uart transparent transmission	HJ-131IMH_SPPv2	Include UART port transparent transmission firmware, the firmware module is a bridge between the Bluetooth device or the mobile phone and the MCU. The Customer does not need to understand the BLE protocol stack, and control the UART port command operation and the UART port data, and the operation is simple, short Development cycle to speed up product launch.
Custom version	HJ-131IMH_CUSv2	This version supports custom firmware, the customer proposes functions according to the product requirements, and we will customize the module with the special version firmware to supply the customer.
Customer development Version	HJ-131IMH_EMP	This version of the module has no built-in firmware, customer can develop their own firmware according to the Dialog official chip datasheet and support documents, and only need to provide firmware for us to burn.



## 7.2 Development Kit Board

We have specially prepared an Kit board for developers. The Kit board leads all GPIOs, and onboard USB TO TTL is convenient for debugging and testing with the computer. At the same time we also provide test documents, please contact our sales for details.

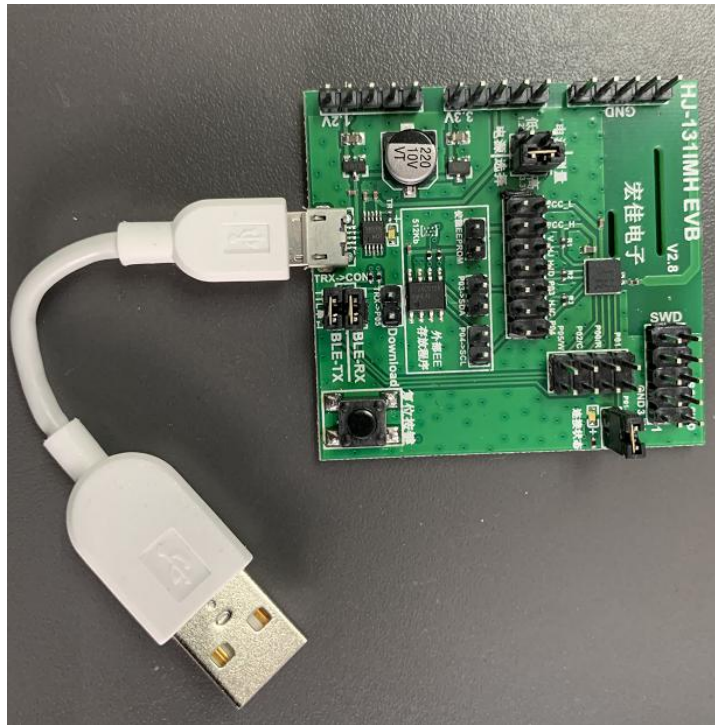

## 7.3 Packaging method

Packaging with tapes and reel. Sealed with chip-level anti-static aluminum foil bag, each bag contains desiccant, use industrial grade vacuum machine to ensure airtight, moisture-proof, waterproof and dustproof (IP65). The actual packing effect is shown in Figure 7-1.



Figure 7-1 External Packing Image

All packages will be labeled with goods information. All packages will be marked with the cargo information, including ROHS and anti-static signs. The production batch information in the item number is 15 bits.



Remarks: P16a I15b S17c001 represents PCB production in January 2016, IC production in February 2015, and SMT patch in the first time in March 2017.

Figure 7-2 Label Sample Diagram

## IMPORTANT NOTICE AND DISCLAIMER

RENESAS ELECTRONICS CORPORATION AND ITS SUBSIDIARIES (“RENESAS”) PROVIDES TECHNICAL SPECIFICATIONS AND RELIABILITY DATA (INCLUDING DATASHEETS), DESIGN RESOURCES (INCLUDING REFERENCE DESIGNS), APPLICATION OR OTHER DESIGN ADVICE, WEB TOOLS, SAFETY INFORMATION, AND OTHER RESOURCES “AS IS” AND WITH ALL FAULTS, AND DISCLAIMS ALL WARRANTIES, EXPRESS OR IMPLIED, INCLUDING, WITHOUT LIMITATION, ANY IMPLIED WARRANTIES OF MERCHANTABILITY, FITNESS FOR A PARTICULAR PURPOSE, OR NON-INFRINGEMENT OF THIRD-PARTY INTELLECTUAL PROPERTY RIGHTS.

These resources are intended for developers who are designing with Renesas products. You are solely responsible for (1) selecting the appropriate products for your application, (2) designing, validating, and testing your application, and (3) ensuring your application meets applicable standards, and any other safety, security, or other requirements. These resources are subject to change without notice. Renesas grants you permission to use these resources only to develop an application that uses Renesas products. Other reproduction or use of these resources is strictly prohibited. No license is granted to any other Renesas intellectual property or to any third-party intellectual property. Renesas disclaims responsibility for, and you will fully indemnify Renesas and its representatives against, any claims, damages, costs, losses, or liabilities arising from your use of these resources. Renesas' products are provided only subject to Renesas' Terms and Conditions of Sale or other applicable terms agreed to in writing. No use of any Renesas resources expands or otherwise alters any applicable warranties or warranty disclaimers for these products.

(Disclaimer Rev.1.01 Jan 2024)

### Corporate Headquarters

TOYOSU FORESIA, 3-2-24 Toyosu,  
Koto-ku, Tokyo 135-0061, Japan  
[www.renesas.com](http://www.renesas.com)

### Trademarks

Renesas and the Renesas logo are trademarks of Renesas Electronics Corporation. All trademarks and registered trademarks are the property of their respective owners.

### Contact Information

For further information on a product, technology, the most up-to-date version of a document, or your nearest sales office, please visit [www.renesas.com/contact-us/](http://www.renesas.com/contact-us/).