

# **HJ-531IMF Ultra-small Chip (5mmx4.75mm,including ANT,1Mb Flash) ultra-low power Bluetooth 5.1 module Datasheet Data Sheet**

**DataSheet version:V1.2**

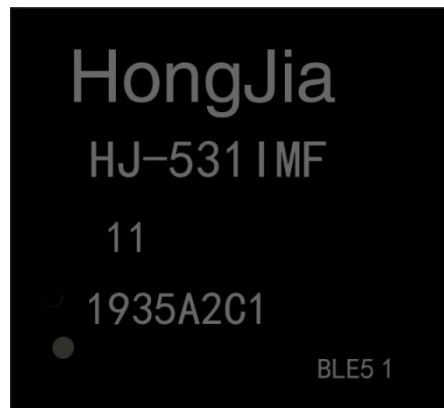

CATALOG

1	Version History.....	- 1 -
2	Overview.....	- 2 -
3	Hardware specification.....	- 4 -
	3.1 Package and dimensions.....	- 4 -
	3.2 Pin Definition.....	- 6 -
	Note: The brackets in "()" are the built-in standard UART transparent transmission firmware function. If the chip is empty, this function is not available.....	- 8 -
	3.3 Internal structure.....	- 8 -
	3.4 Reference Design.....	- 9 -
	3.4.1 Low Voltage Mode (Can be powered by a single AA size battery, voltage range: 1.1-1.65V).....	- 9 -
	3.4.2 High Voltage Mode (voltage range: 1.8V-3.6V) .....	- 9 -
	3.4.3 Using the built-in Flash for save user firmware and support OTA.....	- 10 -
	3.4.4 Using the built-in antenna of the module.....	- 10 -
	3.4.5 Using an external antenna.....	- 11 -
	3.4.5 Notices for Hardware Design.....	- 12 -
	3.4.6 Matters needing attention in the use of products.....	- 12 -
4	Electrical Parameters.....	- 13 -
	4.1 Absolute Maximum Ratings.....	- 13 -
	4.2 Recommended Operating Conditions(Low voltage mode).....	- 13 -
	4.3 I/O DC Characteristics.....	- 13 -
	4.4 RF Features.....	- 14 -
	4.5 Power Dissipation.....	- 14 -
5	Reflow Soldering Information.....	- 15 -
6	Notices for Ultrasound Welding.....	- 16 -
7	Supply Information.....	- 17 -
	7.1 Model Definition.....	- 17 -
	7.2 Packaging method.....	- 17 -

## 1 Version History

Table 1-1 Revision History

No.	Version Number	Release Time	Reviser	Checker	Description
1	V1.0	20200310	LMY	LJH	First edition
2	V1.2	20200512	LMY	ZYP	Update datasheet

## 2 Overview

### 2.1 Features

- Power supply voltage range: 1.8V ~ 3.6V in high voltage mode; 1.1V ~ 1.65V in low voltage mode;
- Can be powered by a single AA battery or a zinc air battery at 1.5V; can also be powered by two AA batteries or a lithium battery after voltage stabilization;
- GPIO maximum number:12
- Size: 5mm\*4.75mm (Includes built-in high-performance ANT and 1Mb flash.External ANT can be expanded)
  
- Memory and ROM
  - Built-in 32KB OTP
  - Built-in 48KB of RAM
  - Includes 1Mb (P25Q10) [Partly 4Mb(PQ25Q40)]of FLASH to user code for OTA .
  
- Function
  - Support BLE 5.1, embedded Bluetooth low energy protocol stack and GATT service
  - BLE supported master-slave integration(Support 1 host-slave or 3 slave. Host and slave work at the same time without affecting each other)
  
- RF Features
  - Operating Frequency: 2.4GHz, Support ISM free Frequency band
  - Transmit Power: -19.5dBm ~ +2.5dBm (Adjustable)
  - High Receive sensitivity: -94dBm
  - TX peak current < 3.5mA; RX peak current <2.2mA;
  - When using the On-board antenna in an open area, the transmission distance of wireless signal can spread more than 5 metres and less than 10 metres.
  - When using an external antenna in an open area, the transmission distance of wireless signal can spread more than 40 metres and less than 80 metres.
  
- Low Power Dissipation

- Dormancy current < 2 $\mu$ A
- Current at 1s broadcast interval: 7 $\mu$ A(0dBm)
- Current at 2s broadcast interval:3.8 $\mu$ A(0dBm)
- Current at 20ms connection gap: 65 $\mu$ A(0dBm)
- Current at 1000ms connection gap: 6.8 $\mu$ A(0dBm)

●Applications

- Tiny medical applications
- Beacons
- Smart toys
- Smart locks
- Remote controls
- Industrial smart devices

●Package: LGA25; pad spacing: 0.6mm; pad size: 0.3mm\*0.5mm

●Size: 5mm\*4.75mm\*1.3mm (Built-in antenna inside)

●Weigh: 1.5g

●Operating temperature range: -40 $^{\circ}$ C ~ +85 $^{\circ}$ C (Maximum temperate up +120 $^{\circ}$ C)

●BQB FCC CE KC SRRC REACH RoHS compliant

### 3 Hardware specification

#### 3.1 Package and dimensions

Package: LGA25, pad spacing: 0.6mm. The detailed dimensions are shown in Figure 3-1, Figure 3-2, Figure 3-3 and Figure 3-4.

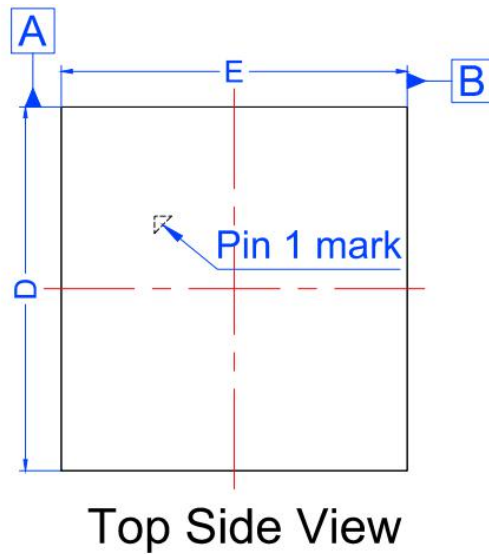

Figure 3-1 Top view

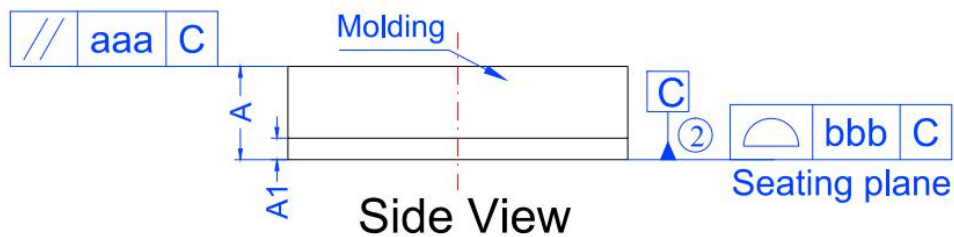
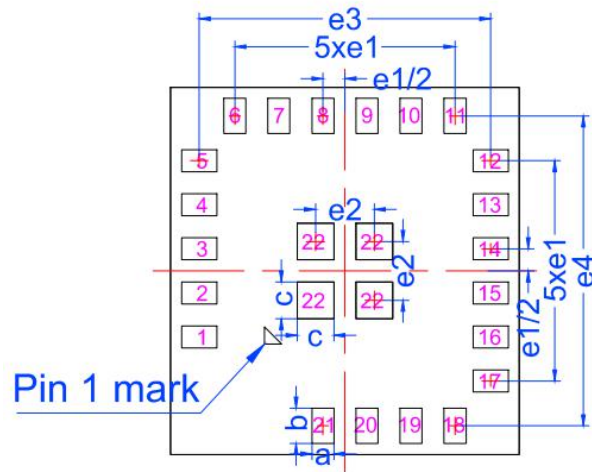

Figure 3-2 Side view



## Bottom Side View

Figure 3-3 Bottom view

*DIMENSIONAL REFERENCES Units:mm*

SYMBOL	DIMENSIONAL REQMTS			SYMBOL	Tolerance of Form & Position
	MIN	NOM	MAX		
<i>A</i>	1.26	1.30	1.34	<i>aaa</i>	0.10
<i>A1</i>	0.27	0.30	0.33	<i>bbb</i>	0.10
<i>D</i>	4.90	5.00	5.10		
<i>E</i>	4.65	4.75	4.85		
<i>a</i>	0.25	0.30	0.35		
<i>b</i>	0.43	0.48	0.53		
<i>c</i>	0.45	0.50	0.55		
<i>e1</i>	0.60 REF				
<i>e2</i>	0.80 REF				
<i>e3</i>	3.97 REF				
<i>e4</i>	4.22 REF				

Note:

1. All dimensions are in mm
- ② Datum 'C' is the mounting surface, with which the package is in contact

Figure 3-4 Dimensions

### 3.2 Pin Definition



Table 3-1 Pin definition table

Pin	Name	Type	Description	Function
1	P0.9 (Connection Status )	GPIO (OUTPUT)	General I/O	Connection status (connection = 1; disconnect = 0)
2	P0.7 (APP data coming point)	GPIO	General I/O	Whether the module is a host or slave, this pin is raised during data is sent out through the TX pin of the module's serial port, and this pin can be lowered only after data is sent out.  Usually this pin keeps a low level to represent idleness. This pin is used as a wake-up sign for long-time connections to low-power devices.
3	P0.5 (UART TX)	GPIO	General I/O	BLE UART TX pin

4	P0.8 (UART receive enable interrupt/UART RX)	GPIO	General I/O	UART receive enable interrupt/function and BLE serial RX (Under low power consumption, the pin defaults to the UART receive enable interrupt pin. If the external high level is increased for more than 1ms, UART receive will enable . After UART receive enable, this pin becomes the UART RX function, which can perform normal data transmission and reception;)
5	P0.2/C	GPIO/Debugger	General I/O	
6	P0.6	GPIO	General I/O	
7	P0.11	GPIO	General I/O	
8	P0.10/W	GPIO/Debugger	General IO/Data port of debug	
9	VCC_LOW	Low Power In	Low voltage power input pin	Low voltage mode input range: 1.1V-1.65V
10	VCC_HIGH	High Power In	High voltage power input pin	High voltage power input range: 1.8V-3.6V
<b>11</b>	<b><i>Flash_vcc</i></b>	<b><i>Flash power In</i></b>	<b><i>Internal Flash power supply pin</i></b>	<b><i>Power supply range 1.65-3.6V, please connect with VCC_HIGH if needed</i></b>
<b>12</b>	<b><i>Flash_sck</i></b>	<b><i>Flash Sck</i></b>	<b><i>Internal Flash clock pin</i></b>	<b><i>If needed, please connect with P0.4</i></b>
13	P0.4/RCM	GPIO	General I/O	
14	P0.3/RCP	GPIO	General I/O	
<b>15</b>	<b><i>Flash_so</i></b>	<b><i>Flash So</i></b>	<b><i>Internal Flash data output pin</i></b>	<b><i>If needed, please connect with P0.3</i></b>
<b>16</b>	<b><i>Flash_si</i></b>	<b><i>Flash Si</i></b>	<b><i>Internal Flash data input pin</i></b>	<b><i>If needed, please connect with P0.0</i></b>
17	P00/RST	GPIO/RST	Reset pin	High-level (1) reset; floating or low-level (0) works normally
<b>18</b>	<b><i>Flash_cs</i></b>	<b><i>Flash Cs</i></b>	<b><i>Internal Flash Chip Select</i></b>	<b><i>If needed, please connect with P0.1</i></b>
19	P0.1	GPIO	General I/O	
20	ANT	RF OUT	RF output pin	RF output, can be external antenna
21	BOARD_ANT	Onboard ANT	On-board antenna input pin	The internal matching circuit has

				been integrated. If you want to use the On-board antenna, you can directly short the 20 and 21 pins.
22	GND	Ground	Power input GND pin	Power negative GND

**Note:** The brackets in "()" are the built-in standard UART transparent transmission firmware function. If the chip is empty, this function is not available.

### 3.3 Internal structure

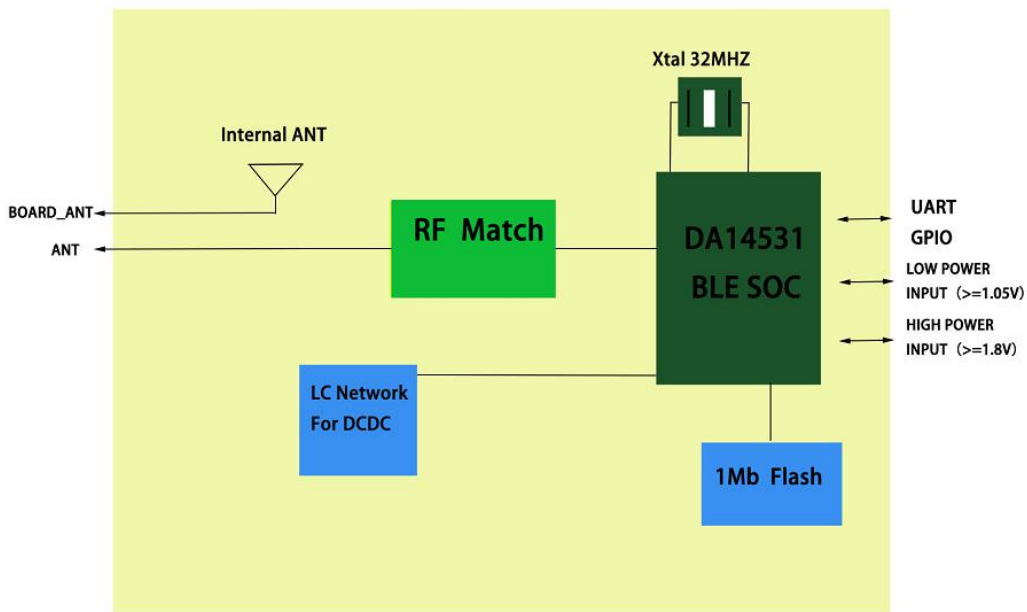

**Focus:** If you use internal ANT, you must 'ANT' connect to 'BOARD\_ANT'

Figure 3-5 HJ-531IMF Internal Block Diagram

### 3.4 Reference Design

#### 3.4.1 Low Voltage Mode (Can be powered by a single AA size battery, voltage range: 1.1-1.65V)

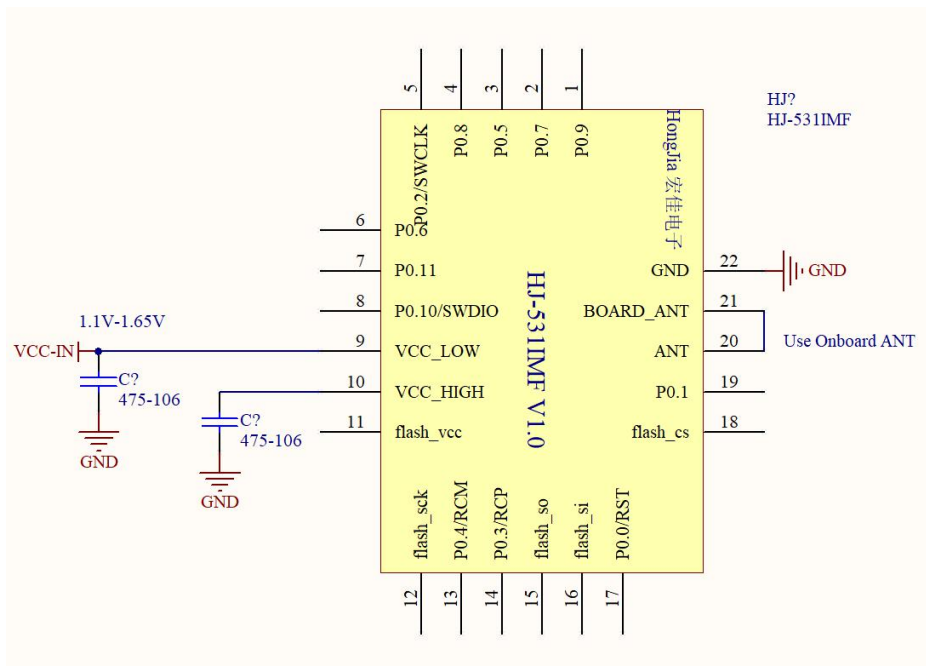

Figure 3-6 HJ-531IMF low-voltage power supply mode

#### 3.4.2 High Voltage Mode (voltage range: 1.8V-3.6V)

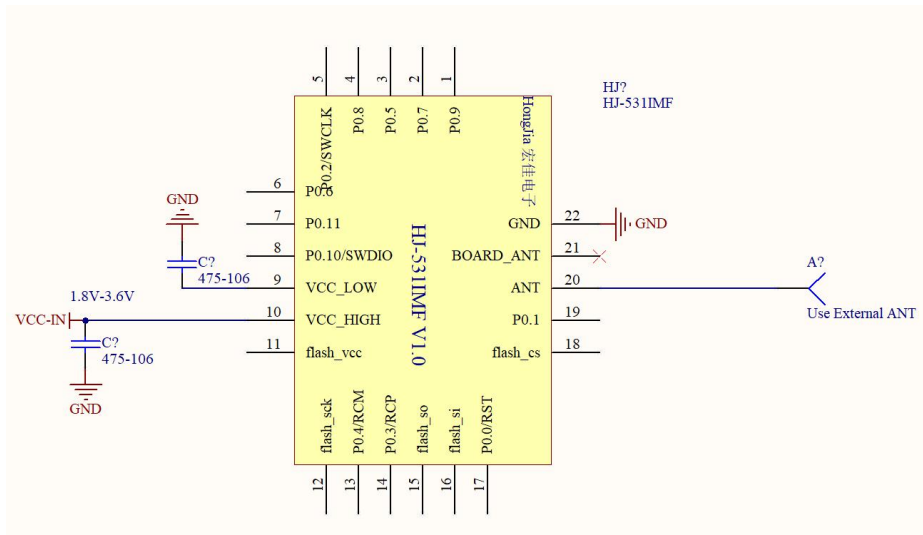
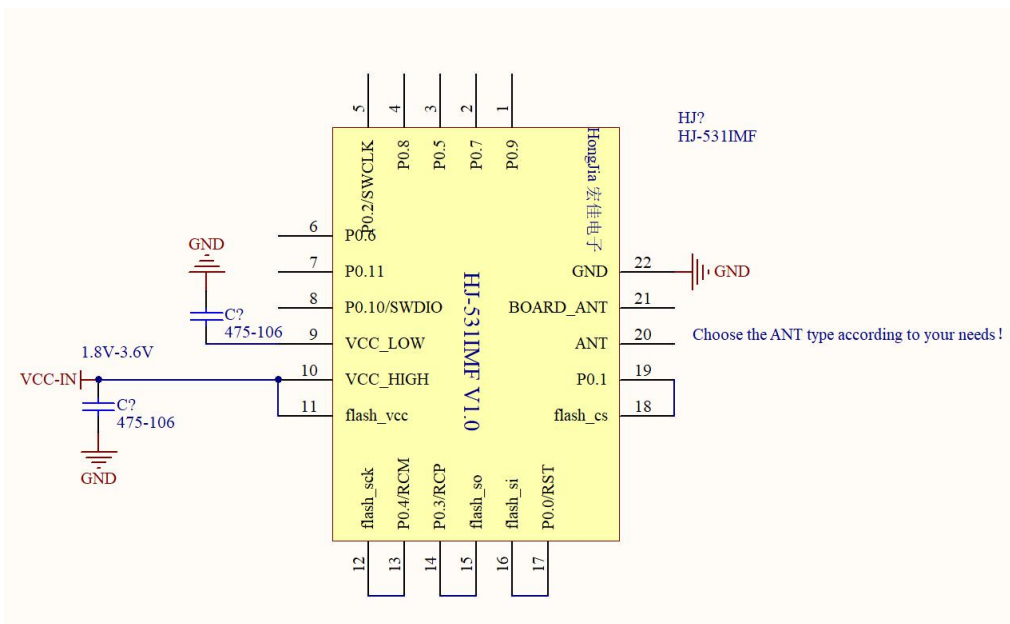
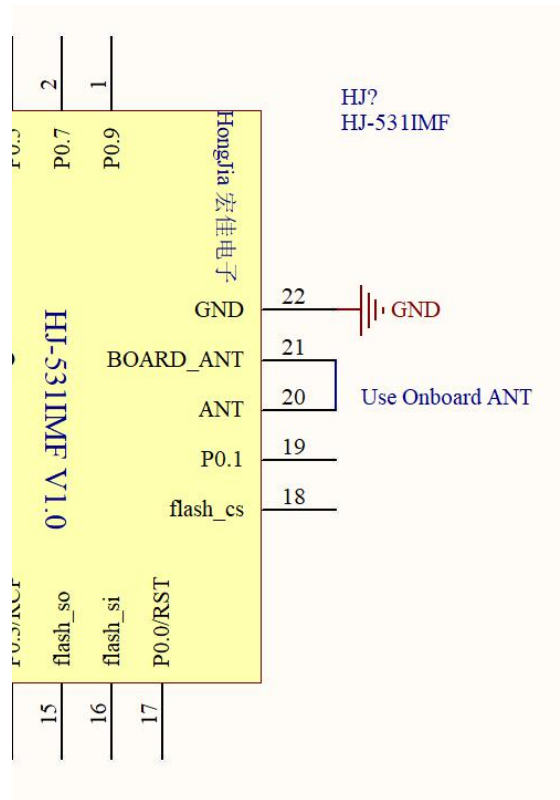

Figure 3-7 HJ-531IMF high voltage power supply mode

### 3.4.3 Using the built-in Flash for save user firmware and support OTA



### 3.4.4 Using the built-in antenna of the module



### 3.4.5 Using an external antenna

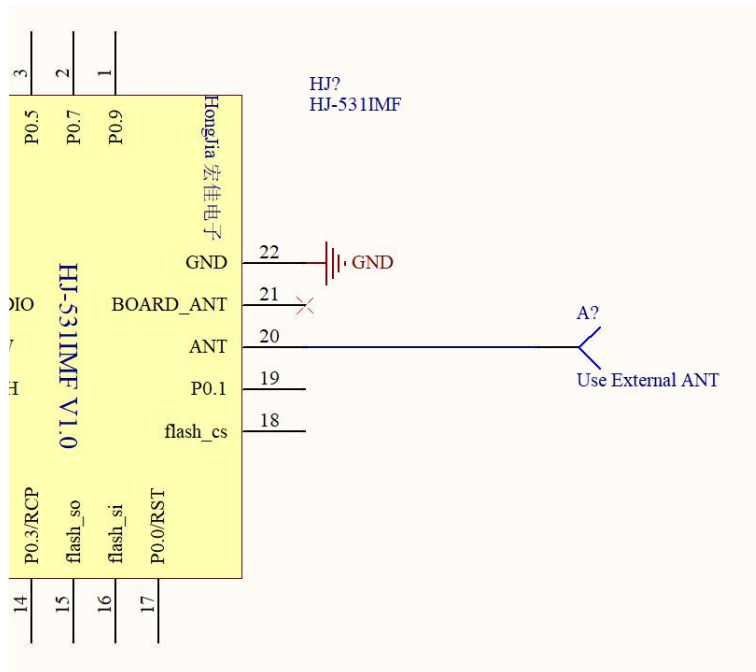

### 3.4.5 Notices for Hardware Design

A. All I/Os can be used.

B. If there is enough space, we recommend adding the PI filter of LC. L? can choose resistor or inductor. Of course, if the space is limited, you can not add it, instead of directly connect a 0603 or 0402 package's ceramic capacitor, capacitance value 475-106.

c、 When using an external antenna, be sure to contact us to let us confirm whether your external PCB antenna or IPEX lead-out antenna PCB design is reasonable.

### 3.4.6 Matters needing attention in the use of products

A. The module should not be placed in a metal-based enclosure. If a metal enclosure is required, the antenna must be lead out.

B. Among the products that need to install this wireless module, some metal materials such as screws, inductors, etc. should be kept away from the RF antenna part of the wireless module.

C. On the wireless module antenna, Do not place other components. Because other components can degrade wireless performance.

D. The wireless module should be placed on the four sides of the motherboard as much as possible. The antenna part should be close to the side or corner of the motherboard. The motherboard PCB under the module antenna should be hollowed out with the keepout layer. If hollowing is prohibited, copper or wiring is not allowed under the antenna. Otherwise it will affect RF performance.

E. Please pay attention to the pin diagram for all pins. Please pay attention to the IO mode and status of the IO connected to it.

F. GND must be sound grounding.

G. It is recommended that magnetic beads or inductance filters be applied to the input power supply.

## 4 Electrical Parameters

### 4.1 Absolute Maximum Ratings

Table 4-1 Absolute maximum ratings

Parameter	MIN	MAX	Unit
Power Supply Voltage (VCC)	1.05	3.8	V
IO Supply Voltage	0	VCC	V
Operating Temperature	-45	+120	°C
Storage Temperature	-55	+135	°C

### 4.2 Recommended Operating Conditions(Low voltage mode)

Table 4-2 Recommended operating conditions

Parameter	MIN	TYP	MAX	Unit
Power Supply Voltage (VCC)	1.8(1.05)	3.3(1.5)	3.6(1.8)	V
IO Supply Voltage	0	3.3(1.8)	VCC	V
Dormant working current		<2		μA
Maximum Operating Current		0.4		mA
Operating Temperature	-40	+25	+85	°C

### 4.3 I/O DC Characteristics

Table 4-3 I/O DC Characteristics

I/O Pin	Driving Capability	MIN	MAX	Unit
Input low voltage		0	0.4	V
Input high voltage		0.7	VCC	V
Output low voltage	5mA	0	0.6	V
Output high voltage	5mA	3.3	VCC	V

## 4.4 RF Features

Table 4-4 RF Features

Attribute	Value	Remarks
Modulation	GFSK	
Frequency range	2.402 ~ 2.480Ghz	Bandwidth: 2Mhz
Number of channels	40	
Air speed	1Mbps	
RF Port Impedance	50Ω	
Transmit Power	MAX: +2.5dbm	
TX Current consumption	TYP: 3.5mA	
RX Current consumption	TYP: 2.2mA	
Receive sensitivity	TYP: -94dbm, MAX: -95dbm	
Antenna	Onboard PCB Antenna	External antenna can be used

## 4.5 Power Dissipation

Table 4-5 Power Dissipation

Test conditions	TYP	Unit
Dormancy mode	<2	μA
20ms Interval Broadcasting in Slave Mode	180	μA
1S Interval Broadcasting in Slave Mode	7.0	μA
20ms Connection Gap Holding Connection in Slave Mode	65	μA
7.5ms Connection Gap Holding Connection in Slave Mode	110	μA
Scanning in Host Mode	2.3	mA
20ms Connection Gap Holding Connection in Host Mode	78	μA

## 5 Reflow Soldering Information

Reflow soldering is recommended for welding.

HJ-131IMH module use high temperature resistant materials, manufacturing by Lead-free Process. The maximum temperature resistance is 265°C. Ten continuous reflow soldering has no effect on properties and strength. Specific parameters as shown in Table 5-1.

Table 5-1 Reflow soldering parameters

Parameter	Value
Features	Lead-free process
Average ramp up rate( $T_{S\text{MAX}}$ to $T_P$ )	3°C/sec. max
Temperature Min( $T_{S\text{min}}$ )	150°C
Temperature Max( $T_{S\text{max}}$ )	200°C
Preheat time (Min to Max) (ts)	80-100 sec.
Peak Temperature ( $T_P$ )	250±5°C
Ramp-down Rate	6°C/sec. max
Time 25°C to Peak Temp ( $T_P$ )	8min. max

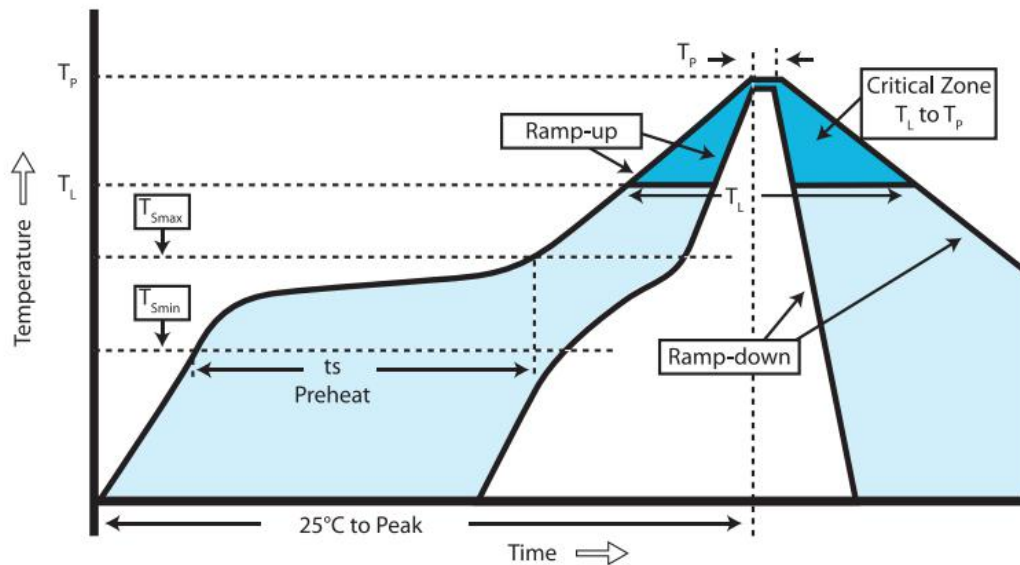

Figure 5-1 Temperature Curve of Reflow Welding

## 6 Notices for Ultrasound Welding

**Warning:** Please carefully consider using ultrasonic welding technology. If it is necessary to use ultrasonic welding technology, please use 40KHz high frequency ultrasound welding technology. Keep the module away from the ultrasonic soldering line and the fixing column during the design method to prevent damage to the module!

For specific ultrasonic welding matters, please contact our company for technical consultation.

## 7 Supply Information

### 7.1 Model Definition

Table 7-1 Model Definition

Type	Model	Description
Standard Edition of uart transparent transmission	HJ-131IMH_SPPv2	Include UART port transparent transmission firmware, the firmware module is a bridge between the Bluetooth device or the mobile phone and the MCU. The Customer does not need to understand the BLE protocol stack, and control the UART port command operation and the UART port data, and the operation is simple, short Development cycle to speed up product launch.
Custom version	HJ-131IMH_CUSv2	This version supports custom firmware, the customer proposes functions according to the product requirements, and we will customize the module with the special version firmware to supply the customer.
Customer development Version	HJ-131IMH_EMP	This version of the module has no built-in firmware, customer can develop their own firmware according to the Dialog DA14531 chip datasheet and support documents.

### 7.2 Packaging method

Packaging with tapes and reel. Sealed with chip-level anti-static aluminum foil bag, each bag contains desiccant, use industrial grade vacuum machine to ensure airtight, moisture-proof, waterproof and dustproof (IP65). The actual packing effect is shown in Figure 7-1.



Figure 7-1 External Packing Image

All packages will be labeled with goods information. All packages will be marked with the cargo information, including ROHS and anti-static signs. The production batch information in the item number is 15 bits.

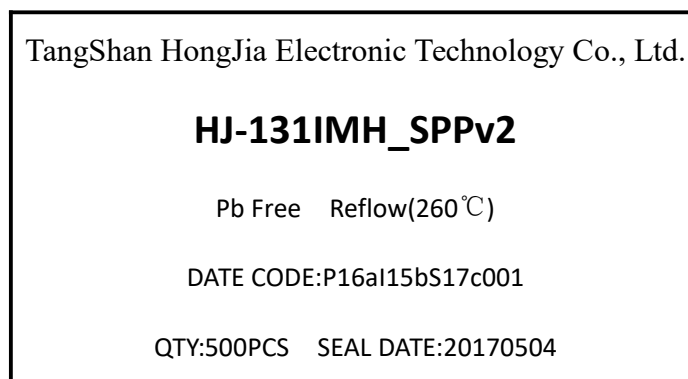

Remarks: P16a I15b S17c001 represents PCB production in January 2016, IC production in February 2015, and SMT patch in the first time in March 2017.

Figure 7-2 Label Sample Diagram

## IMPORTANT NOTICE AND DISCLAIMER

RENESAS ELECTRONICS CORPORATION AND ITS SUBSIDIARIES (“RENESAS”) PROVIDES TECHNICAL SPECIFICATIONS AND RELIABILITY DATA (INCLUDING DATASHEETS), DESIGN RESOURCES (INCLUDING REFERENCE DESIGNS), APPLICATION OR OTHER DESIGN ADVICE, WEB TOOLS, SAFETY INFORMATION, AND OTHER RESOURCES “AS IS” AND WITH ALL FAULTS, AND DISCLAIMS ALL WARRANTIES, EXPRESS OR IMPLIED, INCLUDING, WITHOUT LIMITATION, ANY IMPLIED WARRANTIES OF MERCHANTABILITY, FITNESS FOR A PARTICULAR PURPOSE, OR NON-INFRINGEMENT OF THIRD-PARTY INTELLECTUAL PROPERTY RIGHTS.

These resources are intended for developers who are designing with Renesas products. You are solely responsible for (1) selecting the appropriate products for your application, (2) designing, validating, and testing your application, and (3) ensuring your application meets applicable standards, and any other safety, security, or other requirements. These resources are subject to change without notice. Renesas grants you permission to use these resources only to develop an application that uses Renesas products. Other reproduction or use of these resources is strictly prohibited. No license is granted to any other Renesas intellectual property or to any third-party intellectual property. Renesas disclaims responsibility for, and you will fully indemnify Renesas and its representatives against, any claims, damages, costs, losses, or liabilities arising from your use of these resources. Renesas' products are provided only subject to Renesas' Terms and Conditions of Sale or other applicable terms agreed to in writing. No use of any Renesas resources expands or otherwise alters any applicable warranties or warranty disclaimers for these products.

(Disclaimer Rev.1.01)

### Corporate Headquarters

TOYOSU FORESIA, 3-2-24 Toyosu,  
Koto-ku, Tokyo 135-0061, Japan  
[www.renesas.com](http://www.renesas.com)

### Trademarks

Renesas and the Renesas logo are trademarks of Renesas Electronics Corporation. All trademarks and registered trademarks are the property of their respective owners.

### Contact Information

For further information on a product, technology, the most up-to-date version of a document, or your nearest sales office, please visit [www.renesas.com/contact-us/](http://www.renesas.com/contact-us/).