

LEAD FINISH (SnPb) ARE IN EOL PROCESS - LAST TIME BUY EXPIRES JUNE 15, 2018

FEATURES:

- 256 x 18-bit organization array (IDT72V205)
- 512 x 18-bit organization array (IDT72V215)
- 1,024 x 18-bit organization array (IDT72V225)
- 2,048 x 18-bit organization array (IDT72V235)
- 4,096 x 18-bit organization array (IDT72V245)
- 10 ns read/write cycle time
- 5V input tolerant
- IDT Standard or First Word Fall Through timing
- Single or double register-buffered Empty and Full flags
- Easily expandable in depth and width
- Asynchronous or coincident Read and Write Clocks
- Asynchronous or synchronous programmable Almost-Empty and Almost-Full flags with default settings
- Half-Full flag capability
- Output enable puts output data bus in high-impedance state
- High-performance submicron CMOS technology
- Available in a 64-lead thin quad flatpack (TQFP/STQFP)

- Industrial temperature range (-40°C to +85°C) is available
- Green parts available, see ordering information

DESCRIPTION:

The IDT72V205/72V215/72V225/72V235/72V245 are functionally compatible versions of the IDT72205LB/72215LB/72225LB/72235LB/72245LB, designed to run off a 3.3V supply for exceptionally low power consumption. These devices are very high-speed, low-power First-In, First-Out (FIFO) memories with clocked read and write controls. These FIFOs are applicable for a wide variety of data buffering needs, such as optical disk controllers, Local Area Networks (LANs), and interprocessor communication.

These FIFOs have 18-bit input and output ports. The input port is controlled by a free-running clock (WCLK), and an input enable pin ( $\overline{WEN}$ ). Data is read into the synchronous FIFO on every clock when  $\overline{WEN}$  is asserted. The output port is controlled by another clock pin (RCLK) and another enable pin ( $\overline{REN}$ ). The Read Clock (RCLK) can be tied to the Write Clock for single clock operation or the two clocks can run asynchronous of one another for dual-clock operation. An Output Enable pin ( $\overline{OE}$ ) is provided on the read port for three-state control of the output.

FUNCTIONAL BLOCK DIAGRAM

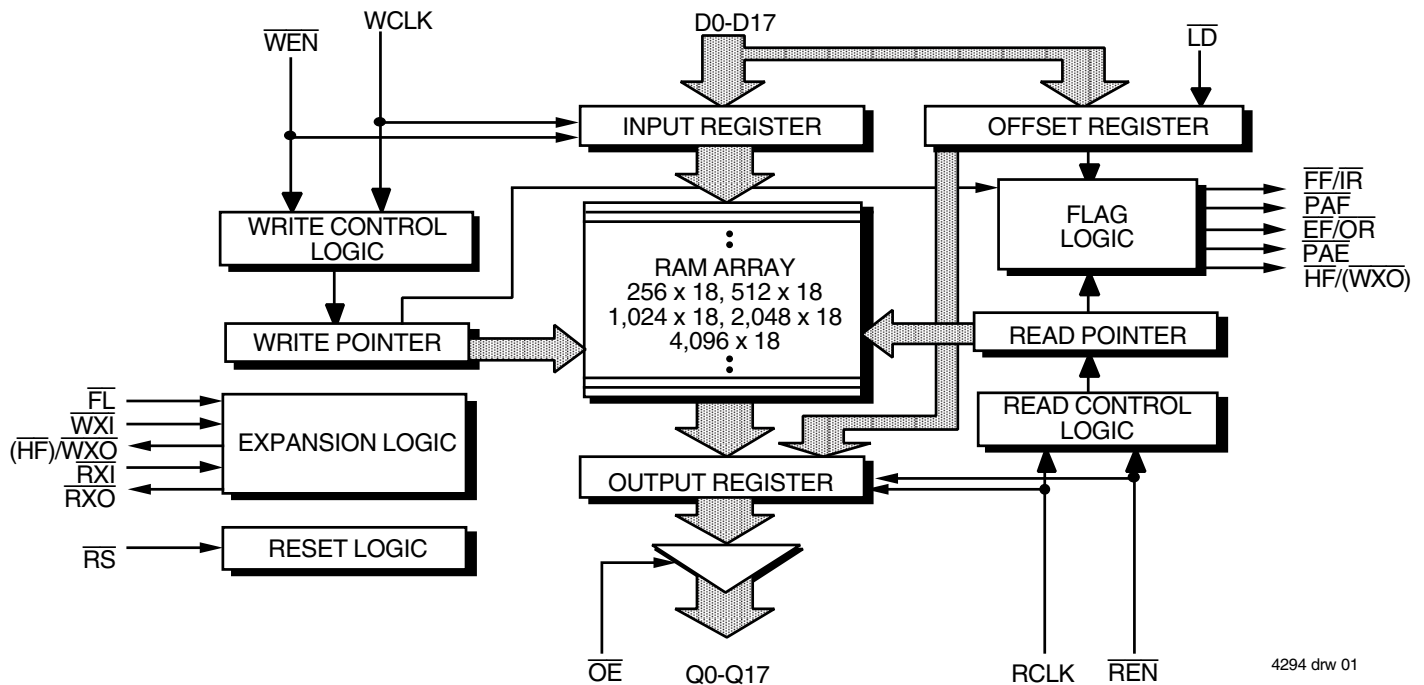

4294 drw 01

## DESCRIPTION (CONTINUED)

The synchronous FIFOs have two fixed flags, Empty Flag/Output Ready ( $\overline{EF}/\overline{OR}$ ) and Full Flag/Input Ready ( $\overline{FF}/\overline{IR}$ ), and two programmable flags, Almost-Empty (PAE) and Almost-Full (PAF). The offset loading of the programmable flags is controlled by a simple state machine, and is initiated by asserting the Load pin ( $\overline{LD}$ ). A Half-Full flag ( $\overline{HF}$ ) is available when the FIFO is used in a single device configuration.

There are two possible timing modes of operation with these devices: IDT Standard mode and First Word Fall-Through (FWFT) mode.

In IDT Standard Mode, the first word written to an empty FIFO will not appear on the data output lines unless a specific read operation is performed. A read

operation, which consists of activating  $\overline{REN}$  and enabling a rising RCLK edge, will shift the word from internal memory to the data output lines.

In FWFT mode, the first word written to an empty FIFO is clocked directly to the data output lines after three transitions of the RCLK signal. A  $\overline{REN}$  does not have to be asserted for accessing the first word.

These devices are depth expandable using a Daisy-Chain technique or First Word Fall Through mode (FWFT). The  $\overline{XI}$  and  $\overline{XO}$  pins are used to expand the FIFOs. In depth expansion configuration, First Load ( $\overline{FL}$ ) is grounded on the first device and set to HIGH for all other devices in the Daisy Chain.

The IDT72V205/72V215/72V225/72V235/72V245 are fabricated using high-speed submicron CMOS technology.

## PIN CONFIGURATIONS

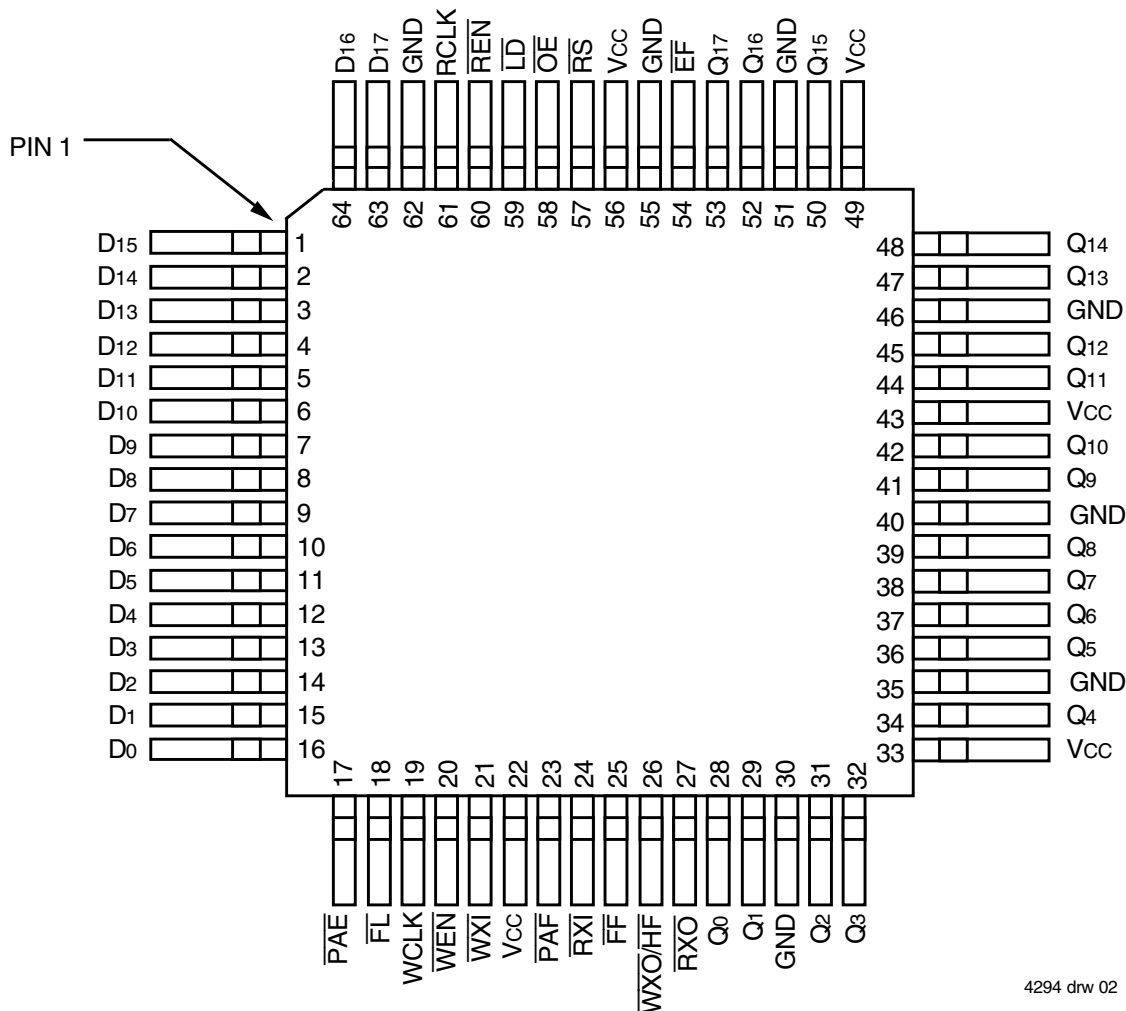

4294 drw 02

TQFP (PN64-1, order code: PF)  
 STQFP (PP64-1, order code: TF)  
 TOP VIEW

## PIN DESCRIPTION

Symbol	Name	I/O	Description
D0–D17	Data Inputs	I	Data inputs for an 18-bit bus.
$\overline{RS}$	Reset	I	When $\overline{RS}$ is set LOW, internal read and write pointers are set to the first location of the RAM array, $\overline{FF}$ and $\overline{PAF}$ go HIGH, and $\overline{PAE}$ and $\overline{EF}$ go LOW. A reset is required before an initial WRITE after power-up.
WCLK	Write Clock	I	When $\overline{WEN}$ is LOW, data is written into the FIFO on a LOW-to-HIGH transition of WCLK, if the FIFO is not full.
$\overline{WEN}$	Write Enable	I	When $\overline{WEN}$ is LOW, data is written into the FIFO on every LOW-to-HIGH transition of WCLK. When $\overline{WEN}$ is HIGH, the FIFO holds the previous data. Data will not be written into the FIFO if the $\overline{FF}$ is LOW.
RCLK	Read Clock	I	When $\overline{REN}$ is LOW, data is read from the FIFO on a LOW-to-HIGH transition of RCLK, if the FIFO is not empty.
$\overline{REN}$	Read Enable	I	When $\overline{REN}$ is LOW, data is read from the FIFO on every LOW-to-HIGH transition of RCLK. When $\overline{REN}$ is HIGH, the output register holds the previous data. Data will not be read from the FIFO if the $\overline{EF}$ is LOW.
$\overline{OE}$	Output Enable	I	When $\overline{OE}$ is LOW, the data output bus is active. If $\overline{OE}$ is HIGH, the output data bus will be in a high-impedance state.
$\overline{LD}$	Load	I	When $\overline{LD}$ is LOW, data on the inputs D0–D11 is written to the offset and depth registers on the LOW-to-HIGH transition of the WCLK, when $\overline{WEN}$ is LOW. When $\overline{LD}$ is LOW, data on the outputs Q0–Q11 is read from the offset and depth registers on the LOW-to-HIGH transition of the RCLK, when $\overline{REN}$ is LOW.
$\overline{FL}$	First Load	I	In the single device or width expansion configuration, $\overline{FL}$ together with $\overline{WXI}$ and $\overline{RXI}$ determine if the mode is IDT Standard mode or First Word Fall Through (FWFT) mode, as well as whether the $\overline{PAE}/\overline{PAF}$ flags are synchronous or asynchronous. (See Table 1.) In the Daisy Chain Depth Expansion configuration, $\overline{FL}$ is grounded on the first device (first load device) and set to HIGH for all other devices in the Daisy Chain.
$\overline{WXI}$	Write Expansion Input	I	In the single device or width expansion configuration, $\overline{WXI}$ together with $\overline{FL}$ and $\overline{RXI}$ determine if the mode is IDT Standard mode or FWFT mode, as well as whether the $\overline{PAE}/\overline{PAF}$ flags are synchronous or asynchronous. (See Table 1.) In the Daisy Chain Depth Expansion configuration, $\overline{WXI}$ is connected to $\overline{WXO}$ (Write Expansion Out) of the previous device.
$\overline{RXI}$	Read Expansion Input	I	In the single device or width expansion configuration, $\overline{RXI}$ together with $\overline{FL}$ and $\overline{WXI}$ , determine if the mode is IDT Standard mode or FWFT mode, as well as whether the $\overline{PAE}/\overline{PAF}$ flags are synchronous or asynchronous. (See Table 1.) In the Daisy Chain Depth Expansion configuration, $\overline{RXI}$ is connected to $\overline{RXO}$ (Read Expansion Out) of the previous device.
$\overline{FF}/\overline{IR}$	Full Flag/ Input Ready	O	In the IDT Standard mode, the $\overline{FF}$ function is selected. $\overline{FF}$ indicates whether or not the FIFO memory is full. In the FWFT mode, the $\overline{IR}$ function is selected. $\overline{IR}$ indicates whether or not there is space available for writing to the FIFO memory.
$\overline{EF}/\overline{OR}$	Empty Flag/ Output Ready	O	In the IDT Standard mode, the $\overline{EF}$ function is selected. $\overline{EF}$ indicates whether or not the FIFO memory is empty. In FWFT mode, the $\overline{OR}$ function is selected. $\overline{OR}$ indicates whether or not there is valid data available at the outputs.
$\overline{PAE}$	Programmable Almost-Empty Flag	O	When $\overline{PAE}$ is LOW, the FIFO is almost-empty based on the offset programmed into the FIFO. The default offset at reset is 31 from empty for IDT72V205, 63 from empty for IDT72V215, and 127 from empty for IDT72V225/72V235/72V245.
$\overline{PAF}$	Programmable Almost-Full Flag	O	When $\overline{PAF}$ is LOW, the FIFO is almost-full based on the offset programmed into the FIFO. The default offset at reset is 31 from full for IDT72V205, 63 from full for IDT72V215, and 127 from full for IDT72V225/72V235/72V245.
$\overline{WXO}/\overline{HF}$	Write Expansion Out/Half-Full Flag	O	In the single device or width expansion configuration, the device is more than half full when $\overline{HF}$ is LOW. In the depth expansion configuration, a pulse is sent from $\overline{WXO}$ to $\overline{WXI}$ of the next device when the last location in the FIFO is written.
$\overline{RXO}$	Read Expansion Out	O	In the depth expansion configuration, a pulse is sent from $\overline{RXO}$ to $\overline{RXI}$ of the next device when the last location in the FIFO is read.
Q0–Q17	Data Outputs	O	Data outputs for an 18-bit bus.
VCC	Power		+3.3V power supply pins.
GND	Ground		Seven ground pins.

## ABSOLUTE MAXIMUM RATINGS

Symbol	Rating	Commercial	Unit
V <sub>TERM</sub> <sup>(2)</sup>	Terminal Voltage with respect to GND	-0.5 to +5	V
T <sub>STG</sub>	Storage Temperature	-55 to +125	°C
I <sub>OUT</sub>	DC Output Current	-50 to +50	mA

### NOTES:

- Stresses greater than those listed under ABSOLUTE MAXIMUM RATINGS may cause permanent damage to the device. This is a stress rating only and functional operation of the device at these or any other conditions above those indicated in the operational sections of this specification is not implied. Exposure to absolute maximum rating conditions for extended periods may affect reliability.
- VCC terminal only.

## RECOMMENDED DC OPERATING CONDITIONS

Symbol	Parameter	Min.	Typ.	Max.	Unit
V <sub>CC</sub>	Supply Voltage Commercial/Industrial	3.0	3.3	3.6	V
GND	Supply Voltage	0	0	0	V
V <sub>IH</sub>	Input High Voltage Commercial/Industrial	2.0	—	5.5	V
V <sub>IL</sub> <sup>(1)</sup>	Input Low Voltage Commercial/Industrial	-0.5	—	0.8	V
T <sub>A</sub>	Operating Temperature Commercial	0	—	70	°C
T <sub>A</sub>	Operating Temperature Industrial	-40	—	85	°C

### NOTE:

- 1.5V undershoots are allowed for 10ns once per cycle.

## DC ELECTRICAL CHARACTERISTICS

(Commercial: V<sub>CC</sub> = 3.3V ± 0.3V, T<sub>A</sub> = 0°C to +70°C; Industrial: V<sub>CC</sub> = 3.3V ± 0.3V, T<sub>A</sub> = -40°C to +85°C)

Symbol	Parameter	IDT72V205 IDT72V215 IDT72V225 IDT72V235 IDT72V245 Commercial & Industrial <sup>(1)</sup> t <sub>CLK</sub> = 10, 15, 20 ns			Unit
		Min.	Typ.	Max.	
I <sub>I</sub> <sup>(2)</sup>	Input Leakage Current (any input)	-1	—	1	μA
I <sub>O</sub> <sup>(3)</sup>	Output Leakage Current	-10	—	10	μA
V <sub>OH</sub>	Output Logic "1" Voltage, I <sub>OH</sub> = -2 mA	2.4	—	—	V
V <sub>OL</sub>	Output Logic "0" Voltage, I <sub>OL</sub> = 8 mA	—	—	0.4	V
I <sub>CC1</sub> <sup>(4,5,6)</sup>	Active Power Supply Current	—	—	30	mA
I <sub>CC2</sub> <sup>(4,7)</sup>	Standby Current	—	—	5	mA

### NOTES:

- Industrial Temperature Range Product for the 15ns speed grade is available as a standard device.
- Measurements with 0.4 ≤ V<sub>IN</sub> ≤ V<sub>CC</sub>.
- $\overline{OE} \geq V_{IH}$ , 0.4 ≤ V<sub>OUT</sub> ≤ V<sub>CC</sub>.
- Tested with outputs disabled (I<sub>OUT</sub> = 0).
- RCLK and WCLK toggle at 20 MHz and data inputs switch at 10 MHz.
- Typical I<sub>CC1</sub> = 2.04 + 0.88\*fs + 0.02\*CL\*fs (in mA).  
These equations are valid under the following conditions:  
V<sub>CC</sub> = 3.3V, T<sub>A</sub> = 25°C, fs = WCLK frequency = RCLK frequency (in MHz, using TTL levels), data switching at fs/2, CL = capacitive load (in pF).
- All Inputs = V<sub>CC</sub> - 0.2V or GND + 0.2V, except RCLK and WCLK, which toggle at 20 MHz.

## CAPACITANCE (T<sub>A</sub> = +25°C, f = 1.0MHz)

Symbol	Parameter <sup>(1)</sup>	Conditions	Max.	Unit
C <sub>IN</sub> <sup>(2)</sup>	Input Capacitance	V <sub>IN</sub> = 0V	10	pF
C <sub>OUT</sub> <sup>(1,2)</sup>	Output Capacitance	V <sub>OUT</sub> = 0V	10	pF

### NOTES:

- With output deselected, ( $\overline{OE} \geq V_{IH}$ ).
- Characterized values, not currently tested.

## AC ELECTRICAL CHARACTERISTICS

(Commercial: VCC = 3.3V ± 0.3V, TA = 0°C to +70°C; Industrial: VCC = 3.3V ± 0.3V, TA = -40°C to +85°C)

Symbol	Parameter	Commercial		Com'l & Ind'l <sup>(1)</sup>		Commercial		Unit
		Min.	Max.	Min.	Max.	Min.	Max.	
f <sub>s</sub>	Clock Cycle Frequency	—	100	—	66.7	—	50	MHz
t <sub>A</sub>	Data Access Time	2	6.5	2	10	2	12	ns
t <sub>CLK</sub>	Clock Cycle Time	10	—	15	—	20	—	ns
t <sub>CLKH</sub>	Clock HIGH Time	4.5	—	6	—	8	—	ns
t <sub>CLKL</sub>	Clock LOW Time	4.5	—	6	—	8	—	ns
t <sub>DS</sub>	Data Set-up Time	3	—	4	—	5	—	ns
t <sub>DH</sub>	Data Hold Time	0.5	—	1	—	1	—	ns
t <sub>ENS</sub>	Enable Set-up Time	3	—	4	—	5	—	ns
t <sub>ENH</sub>	Enable Hold Time	0.5	—	1	—	1	—	ns
t <sub>RS</sub>	Reset Pulse Width <sup>(2)</sup>	10	—	15	—	20	—	ns
t <sub>RSS</sub>	Reset Set-up Time	8	—	10	—	12	—	ns
t <sub>RSR</sub>	Reset Recovery Time	8	—	10	—	12	—	ns
t <sub>RSF</sub>	Reset to Flag and Output Time	—	15	—	15	—	20	ns
t <sub>OLZ</sub>	Output Enable to Output in Low-Z <sup>(3)</sup>	0	—	0	—	0	—	ns
t <sub>OE</sub>	Output Enable to Output Valid	—	6	3	8	3	10	ns
t <sub>OHZ</sub>	Output Enable to Output in High-Z <sup>(3)</sup>	1	6	3	8	3	10	ns
t <sub>WFF</sub>	Write Clock to Full Flag	—	6.5	—	10	—	12	ns
t <sub>REF</sub>	Read Clock to Empty Flag	—	6.5	—	10	—	12	ns
t <sub>PAFA</sub>	Clock to Asynchronous Programmable Almost-Full Flag	—	17	—	20	—	22	ns
t <sub>PAFS</sub>	Write Clock to Synchronous Programmable Almost-Full Flag	—	8	—	10	—	12	ns
t <sub>PAEA</sub>	Clock to Asynchronous Programmable Almost-Empty Flag	—	17	—	20	—	22	ns
t <sub>PAES</sub>	Read Clock to Synchronous Programmable Almost-Empty Flag	—	8	—	10	—	12	ns
t <sub>HF</sub>	Clock to Half-Full Flag	—	17	—	20	—	22	ns
t <sub>EO</sub>	Clock to Expansion Out	—	6.5	—	10	—	12	ns
t <sub>EI</sub>	Expansion In Pulse Width	3	—	6.5	—	8	—	ns
t <sub>EIS</sub>	Expansion In Set-Up Time	3	—	5	—	8	—	ns
t <sub>SKEW1</sub>	Skew time between Read Clock & Write Clock for $\overline{FF}/\overline{IR}$ and $\overline{EF}/\overline{OR}$	5	—	6	—	8	—	ns
t <sub>SKEW2</sub> <sup>(4)</sup>	Skew time between Read Clock & Write Clock for $\overline{PAE}$ and $\overline{PAF}$	14	—	18	—	20	—	ns

### NOTES:

1. Industrial temperature range product for the 15ns speed grade is available as a standard device. All other speed grades are available by special order.
2. Pulse widths less than minimum values are not allowed.
3. Values guaranteed by design, not currently tested.
4. t<sub>SKEW2</sub> applies to synchronous  $\overline{PAE}$  and synchronous  $\overline{PAF}$  only.

## AC TEST CONDITIONS

Input Pulse Levels	GND to 3.0V
Input Rise/Fall Times	3ns
Input Timing Reference Levels	1.5V
Output Reference Levels	1.5V
Output Load	See Figure 1

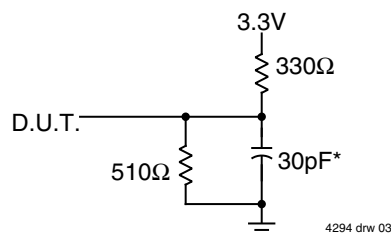

Figure 1. Output Load

\* Includes jig and scope capacitances.



## FUNCTIONAL DESCRIPTION

### TIMING MODES: IDT STANDARD vs FIRST WORD FALL THROUGH (FWFT) MODE

The IDT72V205/72V215/72V225/72V235/72V245 support two different timing modes of operation. The selection of which mode will operate is determined during configuration at Reset ( $\overline{RS}$ ). During a  $\overline{RS}$  operation, the First Load ( $\overline{FL}$ ), Read Expansion Input ( $\overline{RXI}$ ), and Write Expansion Input ( $\overline{WXI}$ ) pins are used to select the timing mode per the truth table shown in Table 3. In IDT Standard Mode, the first word written to an empty FIFO will not appear on the data output lines unless a specific read operation is performed. A read operation, which consists of activating Read Enable ( $\overline{REN}$ ) and enabling a rising Read Clock (RCLK) edge, will shift the word from internal memory to the data output lines. In FWFT mode, the first word written to an empty FIFO is clocked directly to the data output lines after three transitions of the RCLK signal. A  $\overline{REN}$  does not have to be asserted for accessing the first word.

Various signals, both input and output signals operate differently depending on which timing mode is in effect.

#### IDT STANDARD MODE

In this mode, the status flags,  $\overline{FF}$ ,  $\overline{PAF}$ ,  $\overline{HF}$ ,  $\overline{PAE}$ , and  $\overline{EF}$  operate in the manner outlined in Table 1. To write data into the FIFO, Write Enable ( $\overline{WEN}$ ) must be LOW. Data presented to the DATA IN lines will be clocked into the FIFO on subsequent transitions of the Write Clock (WCLK). After the first write is performed, the Empty Flag ( $\overline{EF}$ ) will go HIGH. Subsequent writes will continue to fill up the FIFO. The Programmable Almost-Empty flag ( $\overline{PAE}$ ) will go HIGH after  $n + 1$  words have been loaded into the FIFO, where  $n$  is the empty offset value. The default setting for this value is stated in the footnote of Table 1. This parameter is also user programmable. See section on Programmable Flag Offset Loading.

If one continued to write data into the FIFO, and we assumed no read operations were taking place, the Half-Full Flag ( $\overline{HF}$ ) would toggle to LOW once the 129th (72V205), 257th (72V215), 513th (72V225), 1,025th (72V235), and 2,049th (72V245) word respectively was written into the FIFO. Continuing to write data into the FIFO will cause the Programmable Almost-Full Flag ( $\overline{PAF}$ ) to go LOW. Again, if no reads are performed, the  $\overline{PAF}$  will go LOW after (256- $m$ ) writes for the IDT72V205, (512- $m$ ) writes for the IDT72V215, (1,024- $m$ ) writes for the IDT72V225, (2,048- $m$ ) writes for the IDT72V235 and (4,096- $m$ ) writes for the IDT72V245. The offset " $m$ " is the full offset value. This parameter is also user programmable. See section on Programmable Flag Offset Loading. If there is no full offset specified, the  $\overline{PAF}$  will be LOW when the device is 31 away from completely full for IDT72V205, 63 away from completely full for IDT72V215, and 127 away from completely full for the IDT72V225/72V235/72V245.

When the FIFO is full, the Full Flag ( $\overline{FF}$ ) will go LOW, inhibiting further write operations. If no reads are performed after a reset,  $\overline{FF}$  will go LOW after  $D$  writes to the FIFO.  $D = 256$  writes for the IDT72V205, 512 for the IDT72V215, 1,024 for the IDT72V225, 2,048 for the IDT72V235 and 4,096 for the IDT72V245, respectively.

If the FIFO is full, the first read operation will cause  $\overline{FF}$  to go HIGH. Subsequent read operations will cause  $\overline{PAF}$  and the Half-Full Flag ( $\overline{HF}$ ) to go HIGH at the conditions described in Table 1. If further read operations occur, without write operations, the Programmable Almost-Empty Flag ( $\overline{PAE}$ ) will go LOW when there are  $n$  words in the FIFO, where  $n$  is the empty offset value. If there is no empty offset specified, the  $\overline{PAE}$  will be LOW when the device is 31 away from completely empty for IDT72V205, 63 away from completely empty for IDT72V215, and 127 away from completely empty for IDT72V225/72V235/

72V245. Continuing read operations will cause the FIFO to be empty. When the last word has been read from the FIFO, the  $\overline{EF}$  will go LOW inhibiting further read operations.  $\overline{REN}$  is ignored when the FIFO is empty.

#### FIRST WORD FALL THROUGH MODE (FWFT)

In this mode, the status flags,  $\overline{IR}$ ,  $\overline{PAF}$ ,  $\overline{HF}$ ,  $\overline{PAE}$ , and  $\overline{OR}$  operate in the manner outlined in Table 2. To write data into the FIFO,  $\overline{WEN}$  must be LOW. Data presented to the DATA IN lines will be clocked into the FIFO on subsequent transitions of WCLK. After the first write is performed, the Output Ready ( $\overline{OR}$ ) flag will go LOW. Subsequent writes will continue to fill up the FIFO.  $\overline{PAE}$  will go HIGH after  $n + 2$  words have been loaded into the FIFO, where  $n$  is the empty offset value. The default setting for this value is stated in the footnote of Table 2. This parameter is also user programmable. See section on Programmable Flag Offset Loading.

If one continued to write data into the FIFO, and we assumed no read operations were taking place, the  $\overline{HF}$  would toggle to LOW once the 130th (72V205), 258th (72V215), 514th (72V225), 1,026th (72V235), and 2,050th (72V245) word respectively was written into the FIFO. Continuing to write data into the FIFO will cause the  $\overline{PAF}$  to go LOW. Again, if no reads are performed, the  $\overline{PAF}$  will go LOW after (257- $m$ ) writes for the IDT72V205, (513- $m$ ) writes for the IDT72V215, (1,025- $m$ ) writes for the IDT72V225, (2,049- $m$ ) writes for the IDT72V235 and (4,097- $m$ ) writes for the IDT72V245, where  $m$  is the full offset value. The default setting for this value is stated in the footnote of Table 2.

When the FIFO is full, the Input Ready ( $\overline{IR}$ ) flag will go HIGH, inhibiting further write operations. If no reads are performed after a reset,  $\overline{IR}$  will go HIGH after  $D$  writes to the FIFO.  $D = 257$  writes for the IDT72V205, 513 for the IDT72V215, 1,025 for the IDT72V225, 2,049 for the IDT72V235 and 4,097 for the IDT72V245. Note that the additional word in FWFT mode is due to the capacity of the memory plus output register.

If the FIFO is full, the first read operation will cause the  $\overline{IR}$  flag to go LOW. Subsequent read operations will cause the  $\overline{PAF}$  and  $\overline{HF}$  to go HIGH at the conditions described in Table 2. If further read operations occur, without write operations, the  $\overline{PAE}$  will go LOW when there are  $n + 1$  words in the FIFO, where  $n$  is the empty offset value. If there is no empty offset specified, the  $\overline{PAE}$  will be LOW when the device is 32 away from completely empty for IDT72V205, 64 away from completely empty for IDT72V215, and 128 away from completely empty for IDT72V225/72V235/72V245. Continuing read operations will cause the FIFO to be empty. When the last word has been read from the FIFO,  $\overline{OR}$  will go HIGH inhibiting further read operations.  $\overline{REN}$  is ignored when the FIFO is empty.

#### PROGRAMMABLE FLAG LOADING

Full and Empty flag offset values can be user programmable. The IDT72V205/72V215/72V225/72V235/72V245 has internal registers for these offsets. Default settings are stated in the footnotes of Table 1 and Table 2. Offset values are loaded into the FIFO using the data input lines Do-D11. To load the offset registers, the Load ( $\overline{LD}$ ) pin and  $\overline{WEN}$  pin must be held LOW. Data present on Do-D11 will be transferred into the Empty Offset register on the first LOW-to-HIGH transition of WCLK. By continuing to hold the  $\overline{LD}$  and  $\overline{WEN}$  pin low, data present on Do-D11 will be transferred into the Full Offset register on the next transition of the WCLK. The third transition again writes to the Empty Offset register. Writing all offset registers does not have to occur at one time. One or two offset registers can be written and then by bringing the  $\overline{LD}$  pin HIGH, the FIFO is returned to normal read/write operation. When the  $\overline{LD}$  pin and  $\overline{WEN}$  are again set LOW, the next offset register in sequence is written.

The contents of the offset registers can be read on the data output lines Q0-Q11 when the  $\overline{LD}$  pin is set LOW and  $\overline{REN}$  is set LOW. Data can then be read on the next LOW-to-HIGH transition of RCLK. The first transition of RCLK will present the empty offset value to the data output lines. The next transition of RCLK will present the full offset value. Offset register content can be read out in the IDT Standard mode only. It cannot be read in the FWFT mode.

### SYNCHRONOUS vs ASYNCHRONOUS PROGRAMMABLE FLAG TIMING SELECTION

The IDT72V205/72V215/72V225/72V235/72V245 can be configured during the "Configuration at Reset" cycle described in Table 3 with either asynchronous or synchronous timing for  $\overline{PAE}$  and  $\overline{PAF}$  flags.

If asynchronous  $\overline{PAE}/\overline{PAF}$  configuration is selected (as per Table 3), the  $\overline{PAE}$  is asserted LOW on the LOW-to-HIGH transition of RCLK.  $\overline{PAE}$  is reset to HIGH on the LOW-to-HIGH transition of WCLK. Similarly, the  $\overline{PAF}$  is asserted LOW on the LOW-to-HIGH transition of WCLK and  $\overline{PAF}$  is reset to HIGH on the LOW-to-HIGH transition of RCLK. For detail timing diagrams, see Figure 13 for asynchronous  $\overline{PAE}$  timing and Figure 14 for asynchronous  $\overline{PAF}$  timing.

If synchronous  $\overline{PAE}/\overline{PAF}$  configuration is selected, the  $\overline{PAE}$  is asserted and updated on the rising edge of RCLK only and not WCLK. Similarly,  $\overline{PAF}$  is asserted and updated on the rising edge of WCLK only and not RCLK. For detail timing diagrams, see Figure 22 for synchronous  $\overline{PAE}$  timing and Figure 23 for synchronous  $\overline{PAF}$  timing.

### REGISTER-BUFFERED FLAG OUTPUT SELECTION

The IDT72V205/72V215/72V225/72V235/72V245 can be configured during the "Configuration at Reset" cycle described in Table 4 with single, double or triple register-buffered flag output signals. The various combinations available are described in Table 4 and Table 5. In general, going from single to double or triple buffered flag outputs removes the possibility of metastable flag indications on boundary states (i.e. empty or full conditions). The trade-off is the addition of clock cycle delays for the respective flag to be asserted. Not all combinations of register-buffered flag outputs are supported. Register-buffered outputs apply to the Empty Flag and Full Flag only. Partial flags are not effected. Table 4 and Table 5 summarize the options available.

TABLE 1 — STATUS FLAGS FOR IDT STANDARD MODE

Number of Words in FIFO					$\overline{FF}$	$\overline{PAF}$	$\overline{HF}$	$\overline{PAE}$	$\overline{EF}$
IDT72V205	IDT72V215	IDT72V225	IDT72V235	IDT72V245					
0	0	0	0	0	H	H	H	L	L
1 to n <sup>(1)</sup>	1 to n <sup>(1)</sup>	1 to n <sup>(1)</sup>	1 to n <sup>(1)</sup>	1 to n <sup>(1)</sup>	H	H	H	L	H
(n + 1) to 128	(n + 1) to 256	(n + 1) to 512	(n + 1) to 1,024	(n + 1) to 2,048	H	H	H	H	H
129 to (256-(m+1)) <sup>(2)</sup>	257 to (512-(m+1)) <sup>(2)</sup>	513 to (1,024-(m+1)) <sup>(2)</sup>	1,025 to (2,048-(m+1)) <sup>(2)</sup>	2,049 to (4,096-(m+1)) <sup>(2)</sup>	H	H	L	H	H
(256-m) to 255	(512-m) to 511	(1,024-m) to 1,023	(2,048-m) to 2,047	(4,096-m) to 4,095	H	L	L	H	H
256	512	1,024	2,048	4,096	L	L	L	H	H

NOTES:

- n = Empty Offset (Default Values : IDT72V205 n = 31, IDT72V215 n = 63, IDT72V225/72V235/72V245 n = 127)
- m = Full Offset (Default Values : IDT72V205 m = 31, IDT72V215 m = 63, IDT72V225/72V235/72V245 m = 127)

TABLE 2 — STATUS FLAGS FOR FWFT MODE

Number of Words in FIFO					$\overline{IR}$	$\overline{PAF}$	$\overline{HF}$	$\overline{PAE}$	$\overline{OR}$
IDT72V205	IDT72V215	IDT72V225	IDT72V235	IDT72V245					
0	0	0	0	0	L	H	H	L	H
1 to (n + 1) <sup>(1)</sup>	1 to (n + 1) <sup>(1)</sup>	1 to (n + 1) <sup>(1)</sup>	1 to (n + 1) <sup>(1)</sup>	1 to (n + 1) <sup>(1)</sup>	L	H	H	L	L
(n + 2) to 129	(n + 2) to 257	(n + 2) to 513	(n + 2) to 1,025	(n + 2) to 2,049	L	H	H	H	L
130 to (257-(m+1)) <sup>(2)</sup>	258 to (513-(m+1)) <sup>(2)</sup>	514 to (1,025-(m+1)) <sup>(2)</sup>	1,026 to (2,049-(m+1)) <sup>(2)</sup>	2,050 to (4,097-(m+1)) <sup>(2)</sup>	L	H	L	H	L
(257-m) to 256	(513-m) to 512	(1,025-m) to 1,024	(2,049-m) to 2,048	(4,097-m) to 4,096	L	L	L	H	L
257	513	1,025	2,049	4,097	H	L	L	H	L

NOTES:

- n = Empty Offset (Default Values : IDT72V205 n = 31, IDT72V215 n = 63, IDT72V225/72V235/72V245 n = 127)
- m = Full Offset (Default Values : IDT72V205 m = 31, IDT72V215 m = 63, IDT72V225/72V235/72V245 m = 127)

TABLE 3 — TRUTH TABLE FOR CONFIGURATION AT RESET

$\overline{FL}$	$\overline{RXI}$	$\overline{WXI}$	$\overline{EF/OR}$	$\overline{FF/IR}$	$\overline{PAE}, \overline{PAF}$	FIFO Timing Mode
0	0	0	Single register-buffered Empty Flag	Single register-buffered Full Flag	Asynchronous	Standard
0	0	1	Triple register-buffered Output Ready Flag	Double register-buffered Input Ready Flag	Asynchronous	FWFT
0	1	0	Double register-buffered Empty Flag	Double register-buffered Full Flag	Asynchronous	Standard
0 <sup>(1)</sup>	1	1	Single register-buffered Empty Flag	Single register-buffered Full Flag	Asynchronous	Standard
1	0	0	Single register-buffered Empty Flag	Single register-buffered Full Flag	Synchronous	Standard
1	0	1	Triple register-buffered Output Ready Flag	Double register-buffered Input Ready Flag	Synchronous	FWFT
1	1	0	Double register-buffered Empty Flag	Double register-buffered Full Flag	Synchronous	Standard
1 <sup>(2)</sup>	1	1	Single register-buffered Empty Flag	Single register-buffered Full Flag	Synchronous	Standard

NOTES:

1. In a daisy-chain depth expansion,  $\overline{FL}$  is held LOW for the "first load device". The  $\overline{RXI}$  and  $\overline{WXI}$  inputs are driven by the corresponding  $\overline{RXO}$  and  $\overline{WXO}$  outputs of the preceding device.
2. In a daisy-chain depth expansion,  $\overline{FL}$  is held HIGH for members of the expansion other than the "first load device". The  $\overline{RXI}$  and  $\overline{WXI}$  inputs are driven by the corresponding  $\overline{RXO}$  and  $\overline{WXO}$  outputs of the preceding device.

TABLE 4 — REGISTER-BUFFERED FLAG OUTPUT OPTIONS — IDT STANDARD MODE

Empty Flag ( $\overline{EF}$ ) Buffered Output	Full Flag ( $\overline{FF}$ ) Buffered Output	Partial Flags Timing Mode	Programming at Reset			Flag Timing Diagrams
			$\overline{FL}$	$\overline{RXI}$	$\overline{WXI}$	
Single	Single	Asynch	0	0	0	Figure 9, 10
Single	Single	Sync	1	0	0	Figure 9, 10
Double	Double	Asynch	0	1	0	Figure 24, 26
Double	Double	Sync	1	1	0	Figure 24, 26

TABLE 5 — REGISTER-BUFFERED FLAG OUTPUT OPTIONS — FWFT MODE

Output Ready ( $\overline{OR}$ )	Input Ready ( $\overline{IR}$ )	Partial Flags	Programming at Reset			Flag Timing Diagrams
			$\overline{FL}$	$\overline{RXI}$	$\overline{WXI}$	
Triple	Double	Asynch	0	0	1	Figure 27
Triple	Double	Sync	1	0	1	Figure 20, 21



## SIGNAL DESCRIPTIONS:

### INPUTS:

#### DATA IN (D0 - D17)

Data inputs for 18-bit wide data.

### CONTROLS:

#### RESET ( $\overline{RS}$ )

Reset is accomplished whenever the Reset ( $\overline{RS}$ ) input is taken to a LOW state. During reset, both internal read and write pointers are set to the first location. A reset is required after power-up before a write operation can take place. The Half-Full Flag ( $\overline{HF}$ ) and Programmable Almost-Full Flag ( $\overline{PAF}$ ) will be reset to HIGH after trsf. The Programmable Almost-Empty Flag ( $\overline{PAE}$ ) will be reset to LOW after trsf. The Full Flag ( $\overline{FF}$ ) will reset to HIGH. The Empty Flag ( $\overline{EF}$ ) will reset to LOW in IDT Standard mode but will reset to HIGH in FWFT mode. During reset, the output register is initialized to all zeros and the offset registers are initialized to their default values.

#### WRITE CLOCK (WCLK)

A write cycle is initiated on the LOW-to-HIGH transition of the Write Clock (WCLK). Data setup and hold times must be met with respect to the LOW-to-HIGH transition of WCLK.

The Write and Read Clocks can be asynchronous or coincident.

#### WRITE ENABLE ( $\overline{WEN}$ )

When the  $\overline{WEN}$  input is LOW, data may be loaded into the FIFO RAM array on the rising edge of every WCLK cycle if the device is not full. Data is stored in the RAM array sequentially and independently of any ongoing read operation.

When  $\overline{WEN}$  is HIGH, no new data is written in the RAM array on each WCLK cycle.

To prevent data overflow in the IDT Standard Mode,  $\overline{FF}$  will go LOW, inhibiting further write operations. Upon the completion of a valid read cycle,  $\overline{FF}$  will go HIGH allowing a write to occur. The  $\overline{FF}$  flag is updated on the rising edge of WCLK.

To prevent data overflow in the FWFT mode,  $\overline{IR}$  will go HIGH, inhibiting further write operations. Upon the completion of a valid read cycle,  $\overline{IR}$  will go LOW allowing a write to occur. The  $\overline{IR}$  flag is updated on the rising edge of WCLK.

$\overline{WEN}$  is ignored when the FIFO is full in either FWFT or IDT Standard mode.

#### READ CLOCK (RCLK)

Data can be read on the outputs on the LOW-to-HIGH transition of the Read Clock (RCLK), when Output Enable ( $\overline{OE}$ ) is set LOW.

The Write and Read Clocks can be asynchronous or coincident.

#### READ ENABLE ( $\overline{REN}$ )

When Read Enable is LOW, data is loaded from the RAM array into the output register on the rising edge of every RCLK cycle if the device is not empty.

When the  $\overline{REN}$  input is HIGH, the output register holds the previous data and no new data is loaded into the output register. The data outputs Q0-Qn maintain the previous data value.

In the IDT Standard mode, every word accessed at Qn, including the first word written to an empty FIFO, must be requested using  $\overline{REN}$ . When the last word has been read from the FIFO, the Empty Flag ( $\overline{EF}$ ) will go LOW, inhibiting further read operations.  $\overline{REN}$  is ignored when the FIFO is empty. Once a write is performed,  $\overline{EF}$  will go HIGH allowing a read to occur. The  $\overline{EF}$  flag is updated on the rising edge of RCLK.

In the FWFT mode, the first word written to an empty FIFO automatically goes to the outputs Qn, on the third valid LOW to HIGH transition of RCLK + tsKEW after the first write.  $\overline{REN}$  does not need to be asserted LOW. In order to access all other words, a read must be executed using  $\overline{REN}$ . The RCLK LOW to HIGH transition after the last word has been read from the FIFO, Output Ready ( $\overline{OR}$ ) will go HIGH with a true read (RCLK with  $\overline{REN}$  = LOW), inhibiting further read operations.  $\overline{REN}$  is ignored when the FIFO is empty.

#### OUTPUT ENABLE ( $\overline{OE}$ )

When Output Enable ( $\overline{OE}$ ) is enabled (LOW), the parallel output buffers receive data from the output register. When  $\overline{OE}$  is disabled (HIGH), the Q output data bus is in a high-impedance state.

#### LOAD ( $\overline{LD}$ )

The IDT72V205/72V215/72V225/72V235/72V245 devices contain two 12-bit offset registers with data on the inputs, or read on the outputs. When the Load ( $\overline{LD}$ ) pin is set LOW and  $\overline{WEN}$  is set LOW, data on the inputs D0-D11 is written into the Empty Offset register on the first LOW-to-HIGH transition of the Write Clock (WCLK). When the  $\overline{LD}$  pin and  $\overline{WEN}$  are held LOW then data is written into the Full Offset register on the second LOW-to-HIGH transition of WCLK. The third transition of WCLK again writes to the Empty Offset register.

However, writing all offset registers does not have to occur at one time. One or two offset registers can be written and then by bringing the  $\overline{LD}$  pin HIGH, the FIFO is returned to normal read/write operation. When the  $\overline{LD}$  pin is set LOW, and  $\overline{WEN}$  is LOW, the next offset register in sequence is written.

$\overline{LD}$	$\overline{WEN}$	WCLK	Selection
0	0		Writing to offset registers: Empty Offset Full Offset
0	1		No Operation
1	0		Write Into FIFO
1	1		No Operation

#### NOTE:

- The same selection sequence applies to reading from the registers.  $\overline{REN}$  is enabled and read is performed on the LOW-to-HIGH transition of RCLK.

Figure 2. Writing to Offset Registers

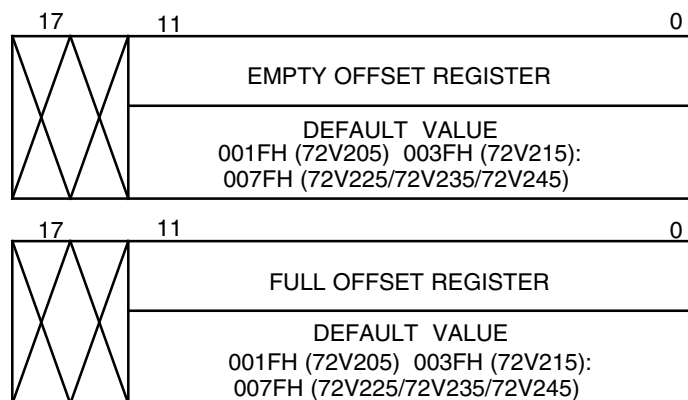

#### NOTE:

- Any bits of the offset register not being programmed should be set to zero.

4294 drw 04

Figure 3. Offset Register Location and Default Values

When the  $\overline{\text{LD}}$  pin is LOW and  $\overline{\text{WEN}}$  is HIGH, the WCLK input is disabled; then a signal at this input can neither increment the write offset register pointer, nor execute a write.

The contents of the offset registers can be read on the output lines when the  $\overline{\text{LD}}$  pin is set LOW and  $\overline{\text{REN}}$  is set LOW; then, data can be read on the LOW-to-HIGH transition of the Read Clock (RCLK). The act of reading the control registers employs a dedicated read offset register pointer. (The read and write pointers operate independently). Offset register content can be read out in the IDT Standard mode only. It is inhibited in the FWFT mode.

A read and a write should not be performed simultaneously to the offset registers.

### FIRST LOAD ( $\overline{\text{FL}}$ )

For the single device mode, see Table 3 for additional information. In the Daisy Chain Depth Expansion configuration,  $\overline{\text{FL}}$  is grounded to indicate it is the first device loaded and is set to HIGH for all other devices in the Daisy Chain. (See Operating Configurations for further details.)

### WRITE EXPANSION INPUT ( $\overline{\text{WXI}}$ )

This is a dual purpose pin. For single device mode, see Table 3 for additional information.  $\overline{\text{WXI}}$  is connected to Write Expansion Out ( $\overline{\text{WXO}}$ ) of the previous device in the Daisy Chain Depth Expansion mode.

### READ EXPANSION INPUT ( $\overline{\text{RXI}}$ )

This is a dual purpose pin. For single device mode, see Table 3 for additional information.  $\overline{\text{RXI}}$  is connected to Read Expansion Out ( $\overline{\text{RXO}}$ ) of the previous device in the Daisy Chain Depth Expansion mode.

## OUTPUTS:

### FULL FLAG/INPUT READY ( $\overline{\text{FF}}/\overline{\text{IR}}$ )

This is a dual purpose pin. In IDT Standard mode, the Full Flag ( $\overline{\text{FF}}$ ) function is selected. When the FIFO is full,  $\overline{\text{FF}}$  will go LOW, inhibiting further write operations. When  $\overline{\text{FF}}$  is HIGH, the FIFO is not full. If no reads are performed after a reset,  $\overline{\text{FF}}$  will go LOW after D writes to the FIFO. D = 256 writes for the IDT72V205, 512 for the IDT72V215, 1,024 for the IDT72V225, 2,048 for the IDT72V235 and 4,096 for the IDT72V245.

In FWFT mode, the Input Ready ( $\overline{\text{IR}}$ ) function is selected.  $\overline{\text{IR}}$  goes LOW when memory space is available for writing in data. When there is no longer any free space left,  $\overline{\text{IR}}$  goes HIGH, inhibiting further write operations.

$\overline{\text{IR}}$  will go HIGH after D writes to the FIFO. D = 257 writes for the IDT72V205, 513 for the IDT72V215, 1,025 for the IDT72V225, 2,049 for the IDT72V235 and 4,097 for the IDT72V245. Note that the additional word in FWFT mode is due to the capacity of the memory plus output register.

$\overline{\text{FF}}/\overline{\text{IR}}$  is synchronous and updated on the rising edge of WCLK.

### EMPTY FLAG/OUTPUT READY ( $\overline{\text{EF}}/\overline{\text{OR}}$ )

This is a dual purpose pin. In the IDT Standard mode, the Empty Flag ( $\overline{\text{EF}}$ ) function is selected. When the FIFO is empty,  $\overline{\text{EF}}$  will go LOW, inhibiting further read operations. When  $\overline{\text{EF}}$  is HIGH, the FIFO is not empty.

In FWFT mode, the Output Ready ( $\overline{\text{OR}}$ ) function is selected.  $\overline{\text{OR}}$  goes LOW at the same time that the first word written to an empty FIFO appears valid on the outputs.  $\overline{\text{OR}}$  stays LOW after the RCLK LOW to HIGH transition that shifts the last word from the FIFO memory to the outputs.  $\overline{\text{OR}}$  goes HIGH only with a true read (RCLK with  $\overline{\text{REN}} = \text{LOW}$ ). The previous data stays at the outputs, indicating the last word was read. Further data reads are inhibited until  $\overline{\text{OR}}$  goes LOW again.

$\overline{\text{EF}}/\overline{\text{OR}}$  is synchronous and updated on the rising edge of RCLK.

### PROGRAMMABLE ALMOST-FULL FLAG ( $\overline{\text{PAF}}$ )

The Programmable Almost-Full Flag ( $\overline{\text{PAF}}$ ) will go LOW when FIFO reaches the almost-full condition. In IDT Standard mode, if no reads are performed after Reset ( $\overline{\text{RS}}$ ), the  $\overline{\text{PAF}}$  will go LOW after (256-m) writes for the IDT72V205, (512-m) writes for the IDT72V215, (1,024-m) writes for the IDT72V225, (2,048-m) writes for the IDT72V235 and (4,096-m) writes for the IDT72V245. The offset "m" is defined in the Full Offset register.

In FWFT mode, if no reads are performed,  $\overline{\text{PAF}}$  will go LOW after 257-m for the IDT72V205, 513-m for the IDT72V215, 1,025 for the IDT72V225, 2,049 for the IDT72V235 and 4,097 for the IDT72V245. The default values for m are noted in Table 1 and 2.

If asynchronous  $\overline{\text{PAF}}$  configuration is selected, the  $\overline{\text{PAF}}$  is asserted LOW on the LOW-to-HIGH transition of the Write Clock (WCLK).  $\overline{\text{PAF}}$  is reset to HIGH on the LOW-to-HIGH transition of the Read Clock (RCLK). If synchronous  $\overline{\text{PAF}}$  configuration is selected (see Table 3), the  $\overline{\text{PAF}}$  is updated on the rising edge of WCLK.

### PROGRAMMABLE ALMOST-EMPTY FLAG ( $\overline{\text{PAE}}$ )

The  $\overline{\text{PAE}}$  flag will go LOW when the FIFO reaches the almost-empty condition. In IDT Standard mode,  $\overline{\text{PAE}}$  will go LOW when there are n words or less in the FIFO. In FWFT mode, the  $\overline{\text{PAE}}$  will go LOW when there are n + 1 words or less in the FIFO. The offset "n" is defined as the empty offset. The default values for n are noted in Table 1 and 2.

If there is no empty offset specified, the Programmable Almost-Empty Flag ( $\overline{\text{PAE}}$ ) will be LOW when the device is 31 away from completely empty for IDT72V205, 63 away from completely empty for IDT72V215, and 127 away from completely empty for IDT72V225/72V235/72V245.

If asynchronous  $\overline{\text{PAE}}$  configuration is selected, the  $\overline{\text{PAE}}$  is asserted LOW on the LOW-to-HIGH transition of the Read Clock (RCLK).  $\overline{\text{PAE}}$  is reset to HIGH on the LOW-to-HIGH transition of the Write Clock (WCLK). If synchronous  $\overline{\text{PAE}}$  configuration is selected (see Table 3), the  $\overline{\text{PAE}}$  is updated on the rising edge of RCLK.

### WRITE EXPANSION OUT/HALF-FULL FLAG ( $\overline{\text{WXO}}/\overline{\text{HF}}$ )

This is a dual-purpose output. In the Single Device and Width Expansion mode, when Write Expansion In ( $\overline{\text{WXI}}$ ) and/or Read Expansion In ( $\overline{\text{RXI}}$ ) are grounded, this output acts as an indication of a half-full memory.

After half of the memory is filled, and at the LOW-to-HIGH transition of the next write cycle, the Half-Full Flag goes LOW and will remain set until the difference between the write pointer and read pointer is less than or equal to one half of the total memory of the device. The Half-Full Flag ( $\overline{\text{HF}}$ ) is then reset to HIGH by the LOW-to-HIGH transition of the Read Clock (RCLK). The  $\overline{\text{HF}}$  is asynchronous.

In the Daisy Chain Depth Expansion mode,  $\overline{\text{WXI}}$  is connected to  $\overline{\text{WXO}}$  of the previous device. This output acts as a signal to the next device in the Daisy Chain by providing a pulse when the previous device writes to the last location of memory.

### READ EXPANSION OUT ( $\overline{\text{RXO}}$ )

In the Daisy Chain Depth Expansion configuration, Read Expansion In ( $\overline{\text{RXI}}$ ) is connected to Read Expansion Out ( $\overline{\text{RXO}}$ ) of the previous device. This output acts as a signal to the next device in the Daisy Chain by providing a pulse when the previous device reads from the last location of memory.

### DATA OUTPUTS (Q0-Q17)

Q0-Q17 are data outputs for 18-bit wide data.

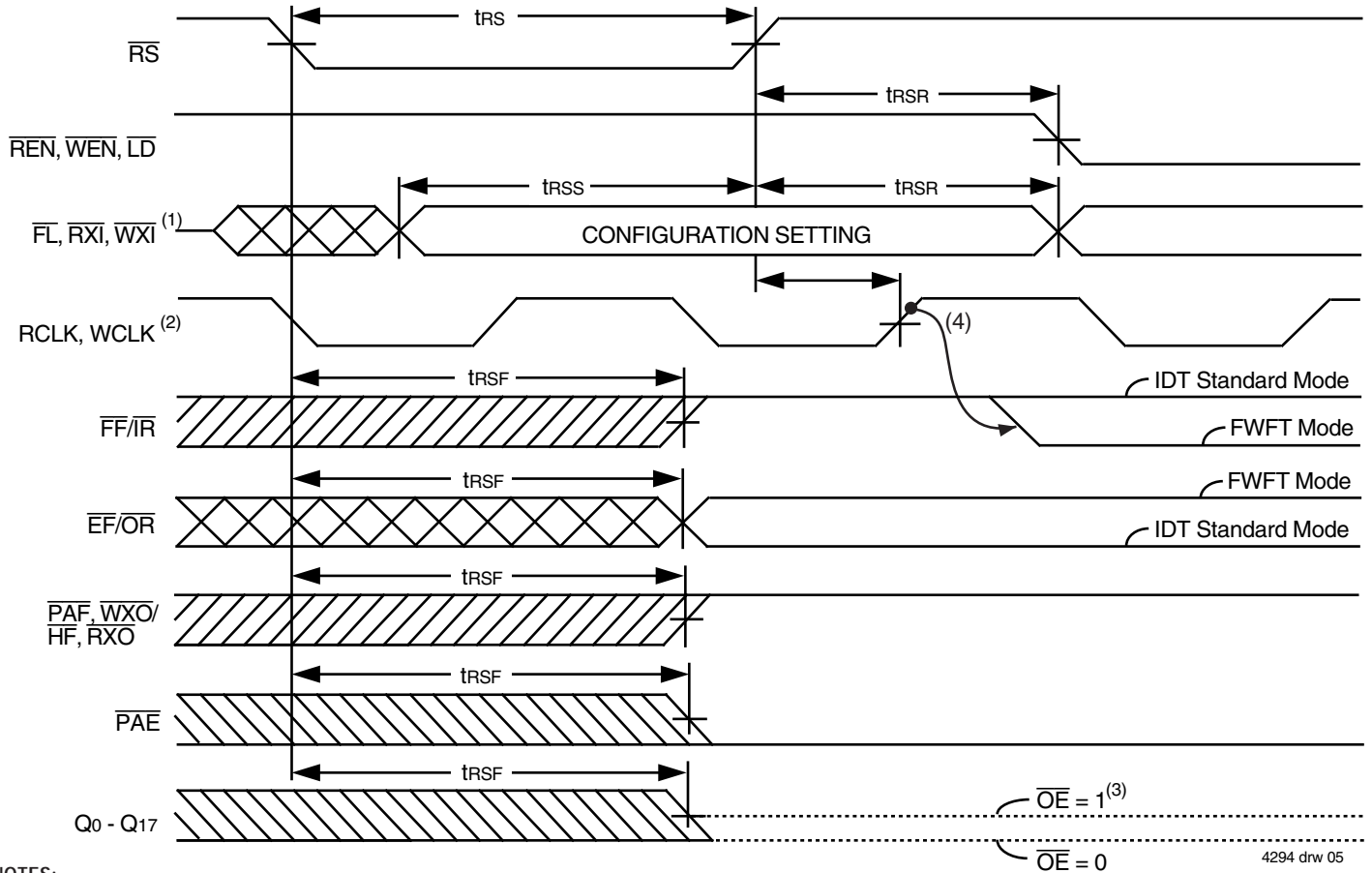

NOTES:

1. Single device mode ( $\overline{FL}$ ,  $\overline{RXI}$ ,  $\overline{WXI}$ ) = (0,0,0), (0,0,1), (0,1,0), (1,0,0), (1,0,1) or (1,1,0).  $\overline{FL}$ ,  $\overline{RXI}$ ,  $\overline{WXI}$  should be static (tied to  $V_{CC}$  or GND).
2. The clocks (RCLK, WCLK) can be free-running asynchronously or coincidentally.
3. After reset, the outputs will be LOW if  $\overline{OE} = 0$  and tri-state if  $\overline{OE} = 1$ .
4. In FWFT mode  $\overline{IR}$  goes LOW based on the WCLK edge after Reset.

Figure 5. Reset Timing<sup>(2)</sup>

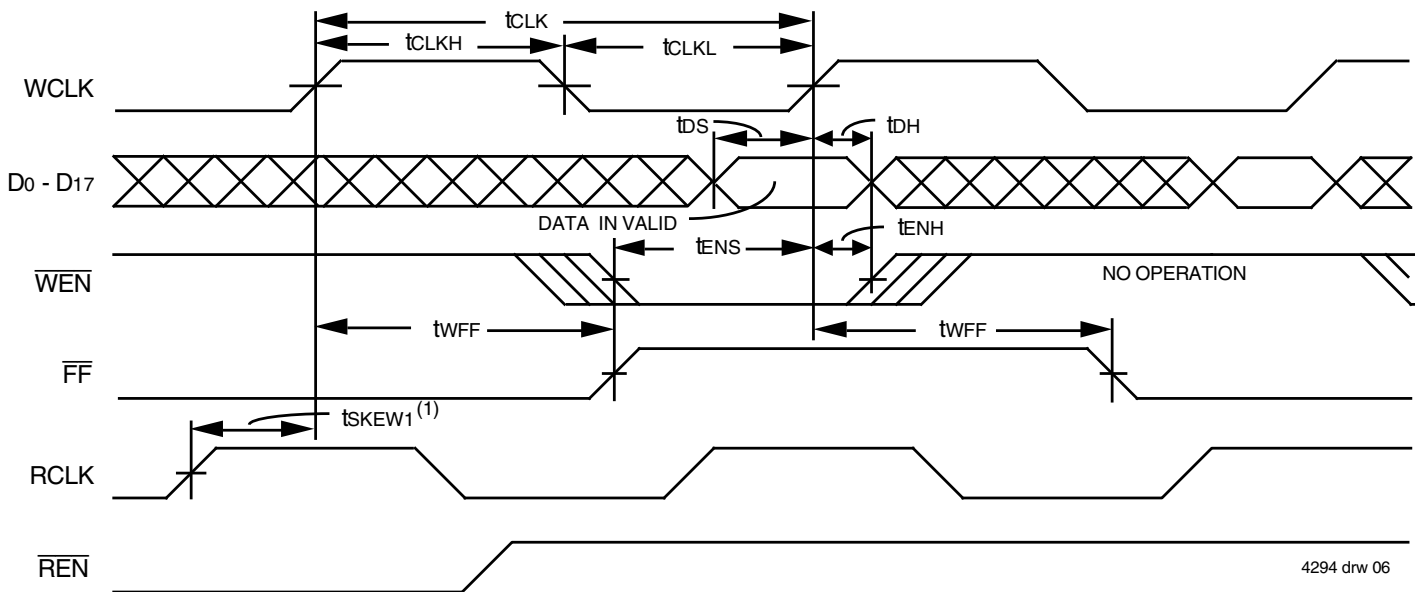

NOTES:

1.  $t_{SKEW1}$  is the minimum time between a rising RCLK edge and a rising WCLK edge to guarantee that  $\overline{FF}$  will go HIGH during the current clock cycle. If the time between the rising edge of RCLK and the rising edge of WCLK is less than  $t_{SKEW1}$ , then  $\overline{FF}$  may not change state until the next WCLK edge.
2. Select this mode by setting ( $\overline{FL}$ ,  $\overline{RXI}$ ,  $\overline{WXI}$ ) = (0,0,0), (0,1,1), (1,0,0) or (1,1,1) during Reset.

Figure 6. Write Cycle Timing with Single Register-Buffered  $\overline{FF}$  (IDT Standard Mode)

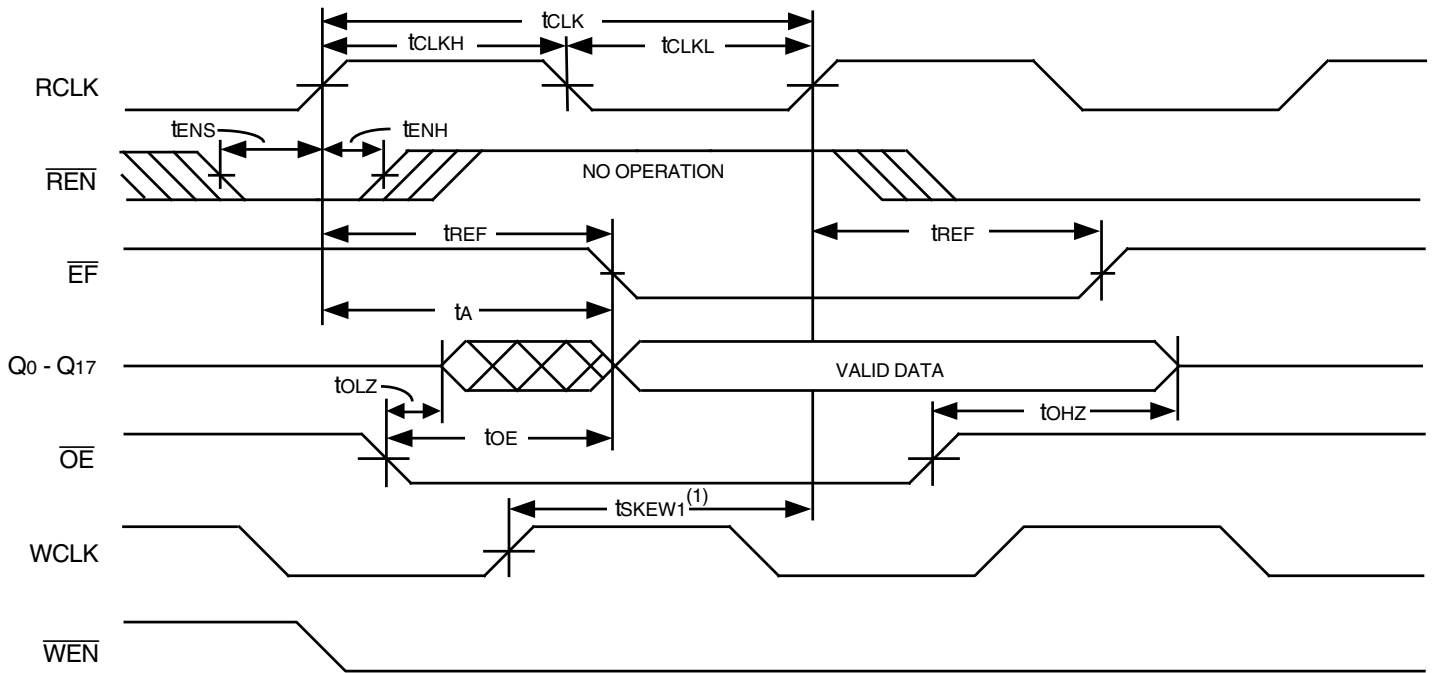

4294 drw 07

NOTES:

1.  $tsKEW1$  is the minimum time between a rising WCLK edge and a rising RCLK edge to guarantee that  $\overline{EF}$  will go HIGH during the current clock cycle. If the time between the rising edge of WCLK and the rising edge of RCLK is less than  $tsKEW1$ , then  $\overline{EF}$  may not change state until the next RCLK edge.
2. Select this mode by setting  $(\overline{FL}, \overline{RXI}, \overline{WXI}) = (0,0,0), (0,1,1), (1,0,0)$  or  $(1,1,1)$  during Reset.

Figure 7. Read Cycle Timing with Single Register-Buffered  $\overline{EF}$  (IDT Standard Mode)

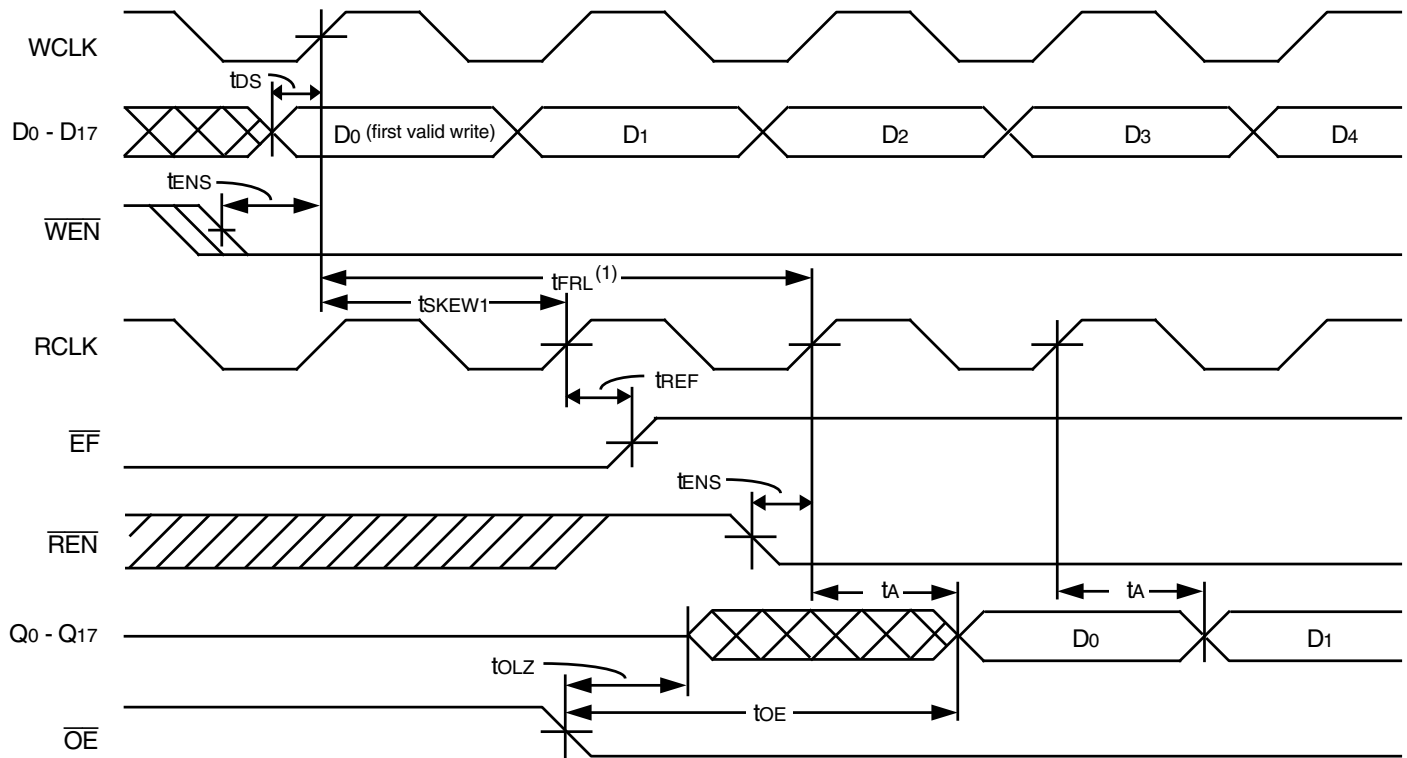

4294 drw 08

NOTES:

1. When  $tsKEW1$  minimum specification,  $tFRL$  (maximum) =  $tCLK + tsKEW1$ . When  $tsKEW1 < \text{minimum specification}$ ,  $tFRL$  (maximum) = either  $2 \cdot tCLK + tsKEW1$  or  $tCLK + tsKEW1$ . The Latency Timing applies only at the Empty Boundary ( $\overline{EF} = \text{LOW}$ ).
2. The first word is available the cycle after  $\overline{EF}$  goes HIGH, always.
3. Select this mode by setting  $(\overline{FL}, \overline{RXI}, \overline{WXI}) = (0,0,0), (0,1,1), (1,0,0)$  or  $(1,1,1)$  during Reset.

Figure 8. First Data Word Latency with Single Register-Buffered  $\overline{EF}$  (IDT Standard Mode)

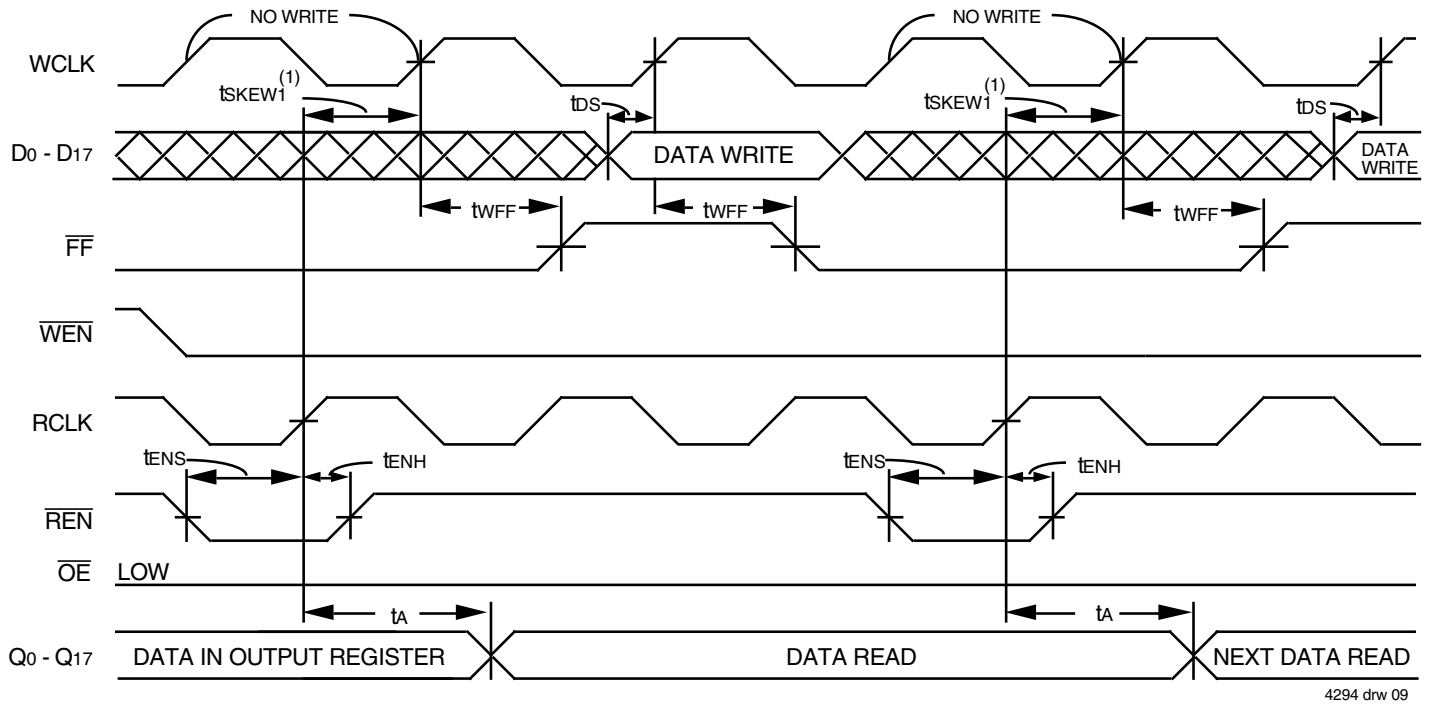

- NOTES:
1.  $t_{sKEW1}$  is the minimum time between a rising RCLK edge and a rising WCLK edge to guarantee that  $\overline{FF}$  will go HIGH during the current clock cycle. If the time between the rising edge of RCLK and the rising edge of WCLK is less than  $t_{sKEW1}$ , then  $\overline{FF}$  may not change state until the next WCLK edge.
  2. Select this mode by setting  $(\overline{FL}, \overline{RXI}, \overline{WXI}) = (0,0,0), (0,1,1), (1,0,0)$  or  $(1,1,1)$  during Reset.

Figure 9. Single Register-Buffered Full Flag Timing (IDT Standard Mode)

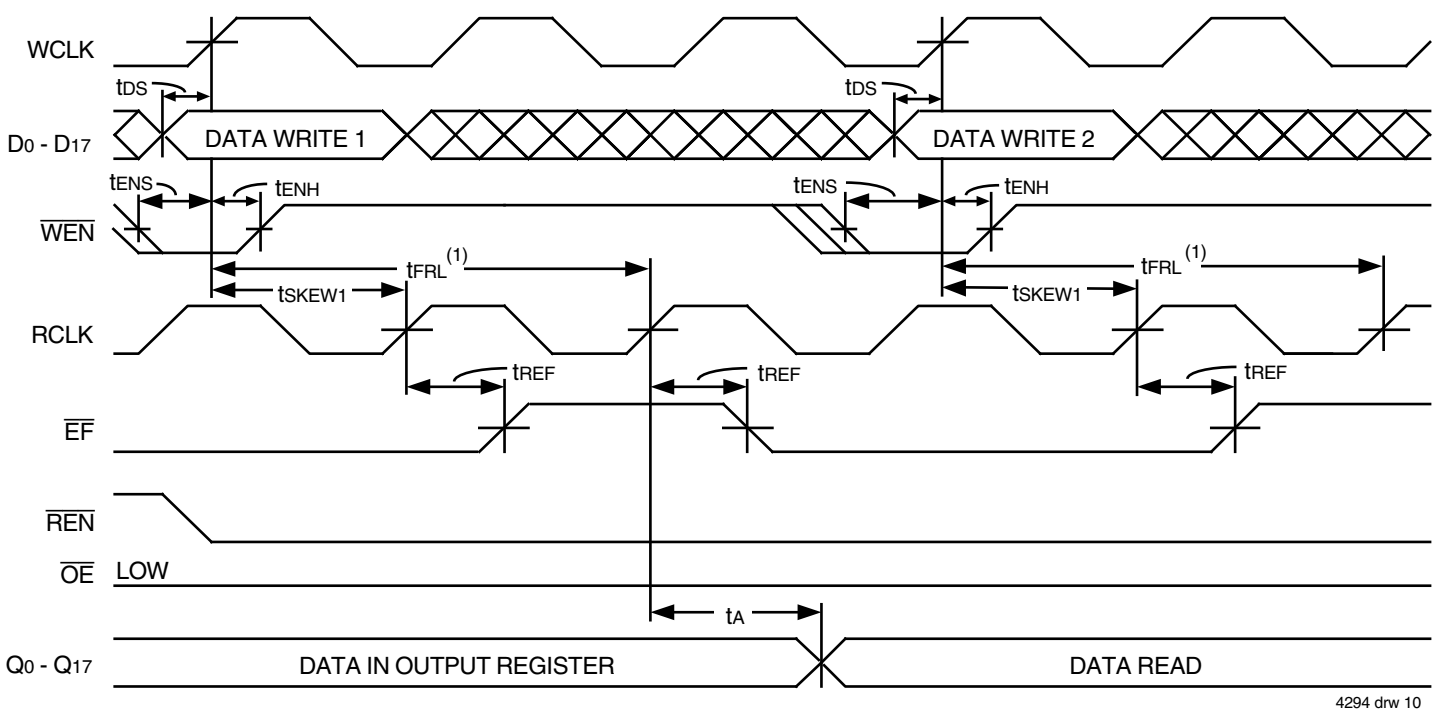

- NOTES:
1. When  $t_{sKEW1}$  minimum specification,  $t_{FRL}$  (maximum) =  $t_{CLK} + t_{sKEW1}$ . When  $t_{sKEW1} <$  minimum specification,  $t_{FRL}$  (maximum) = either  $2 * t_{CLK} + t_{sKEW1}$ , or  $t_{CLK} + t_{sKEW1}$ . The Latency Timing apply only at the Empty Boundary ( $\overline{EF} = \text{LOW}$ ).
  2. Select this mode by setting  $(\overline{FL}, \overline{RXI}, \overline{WXI}) = (0,0,0), (0,1,1), (1,0,0)$  or  $(1,1,1)$  during Reset.

Figure 10. Single Register-Buffered Empty Flag Timing (IDT Standard Mode)

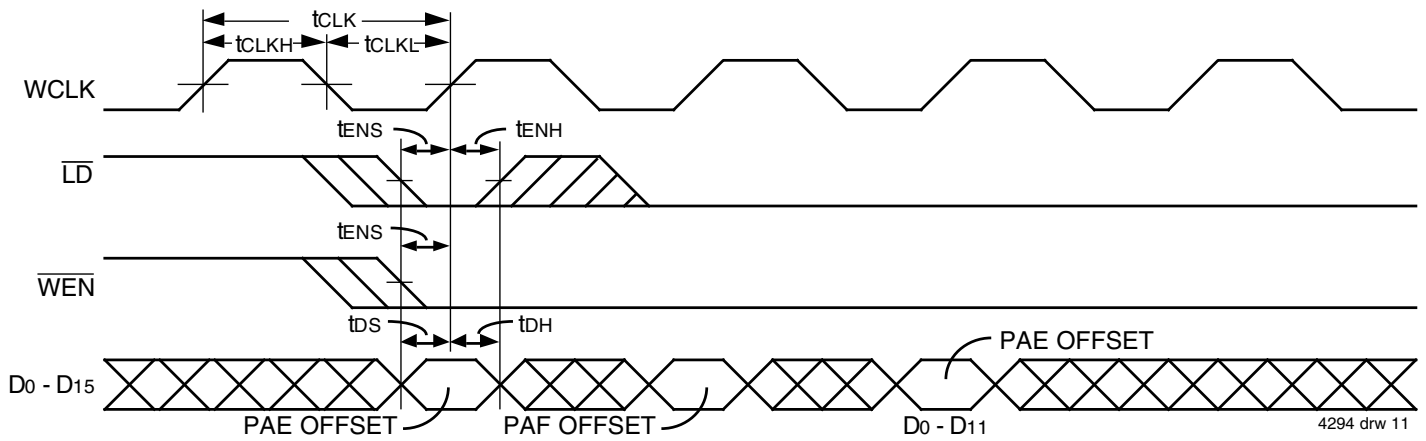

Figure 11. Write Programmable Registers (IDT Standard and FWFT Modes)

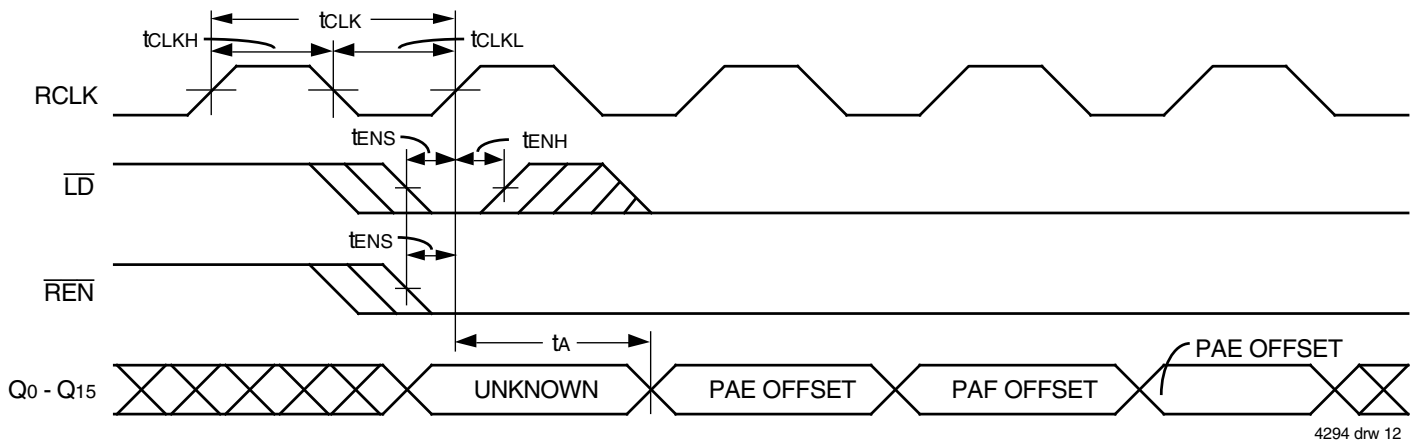
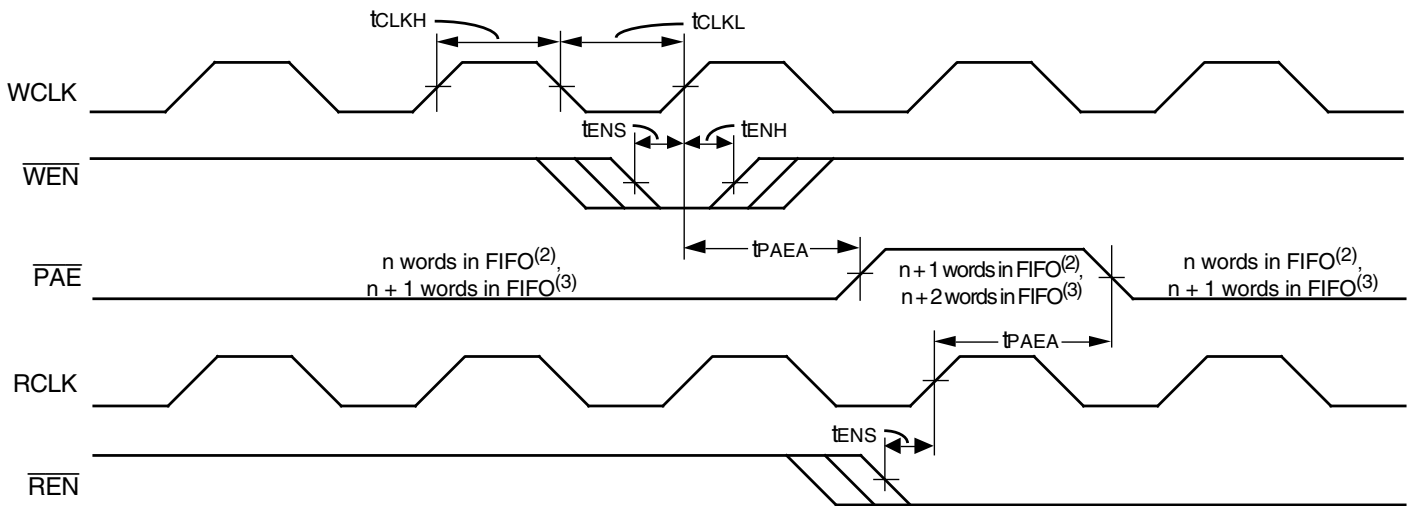

Figure 12. Read Programmable Registers (IDT Standard Mode)



NOTES:

1.  $n = \overline{\text{PAE}}$  offset.
2. For IDT Standard Mode.
3. For FWFT Mode.
4.  $\overline{\text{PAE}}$  is asserted LOW on RCLK transition and reset to HIGH on WCLK transition.
5. Select this mode by setting  $(\overline{\text{FL}}, \overline{\text{RXI}}, \overline{\text{WXI}}) = (0,0,0), (0,0,1), (0,1,0), (0,1,1)$  or  $(1,1,1)$  during Reset.

Figure 13. Asynchronous Programmable Almost-Empty Flag Timing (IDT Standard and FWFT Modes)



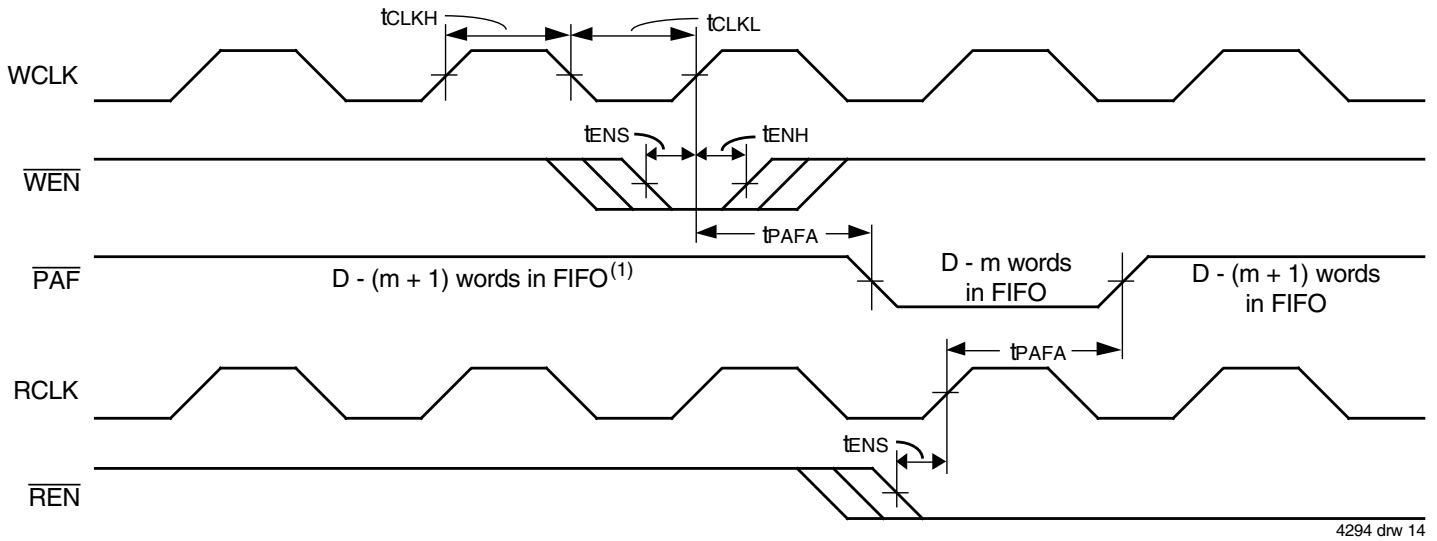

4294 drw 14

**NOTES:**

1. m = PAF offset.
2. D = maximum FIFO Depth.  
 In IDT Standard Mode: D = 256 for the IDT72V205, 512 for the IDT72V215, 1,024 for the IDT72V225, 2,048 for the IDT72V235 and 4,096 for the IDT72V245.  
 In FWFT Mode: D = 257 for the IDT72V205, 513 for the IDT72V215, 1,025 for the IDT72V225, 2,049 for the IDT72V235 and 4,097 for the IDT72V245.
3. PAF is asserted to LOW on WCLK transition and reset to HIGH on RCLK transition.
4. Select this mode by setting (FL, RXI, WXI) = (0,0,0), (0,0,1), (0,1,0), (0,1,1) or (1,1,1) during Reset.

**Figure 14. Asynchronous Programmable Almost-Full Flag Timing (IDT Standard and FWFT Modes)**

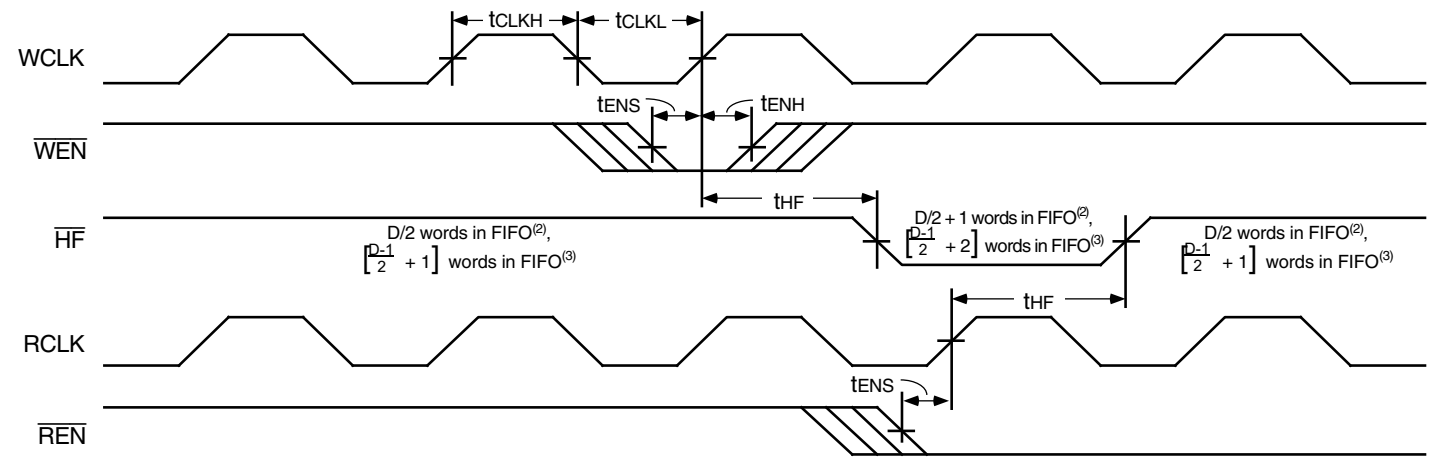

4294 drw 15

**NOTES:**

1. D = maximum FIFO Depth.  
 In IDT Standard Mode: D = 256 for the IDT72V205, 512 for the IDT72V215, 1,024 for the IDT72V225, 2,048 for the IDT72V235 and 4,096 for the IDT72V245.  
 In FWFT Mode: D = 257 for the IDT72V205, 513 for the IDT72V215, 1,025 for the IDT72V225, 2,049 for the IDT72V235 and 4,097 for the IDT72V245.
2. For IDT Standard Mode.
3. For FWFT Mode.
4. Select this mode by setting (FL, RXI, WXI) = (0,0,0), (0,0,1), (0,1,0), (1,0,0), (1,0,1) or (1,1,0) during Reset.

**Figure 15. Half-Full Flag Timing (IDT Standard and FWFT Modes)**

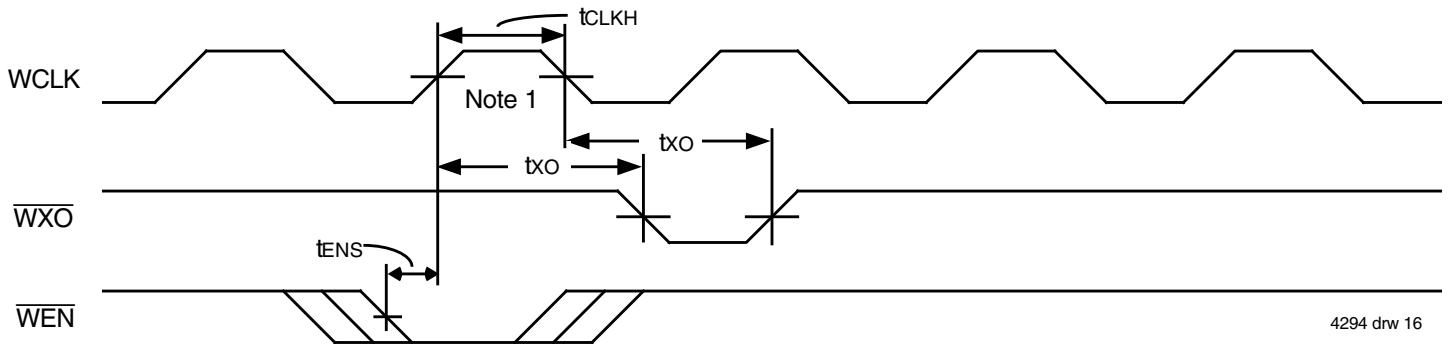

4294 drw 16

NOTE:  
 1. Write to Last Physical Location.

Figure 16. Write Expansion Out Timing

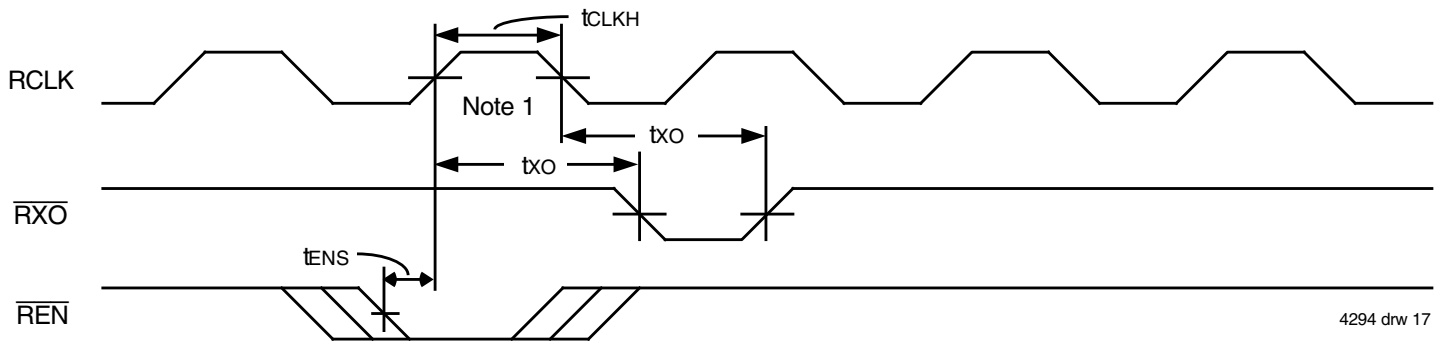

4294 drw 17

NOTE:  
 1. Read from Last Physical Location.

Figure 17. Read Expansion Out Timing

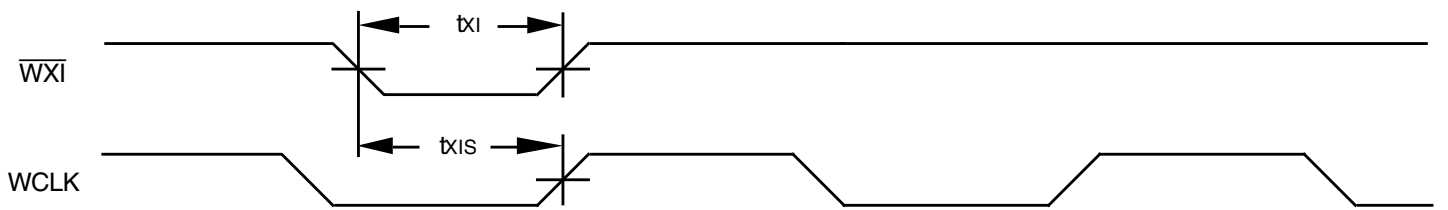

4294 drw 18

Figure 18. Write Expansion In Timing

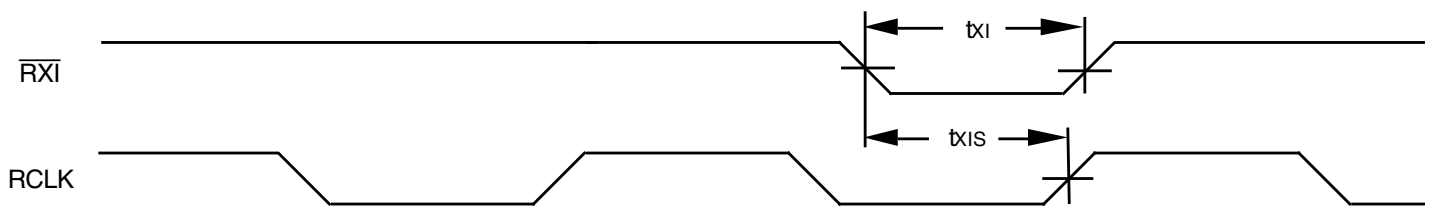

4294 drw 19

Figure 19. Read Expansion In Timing

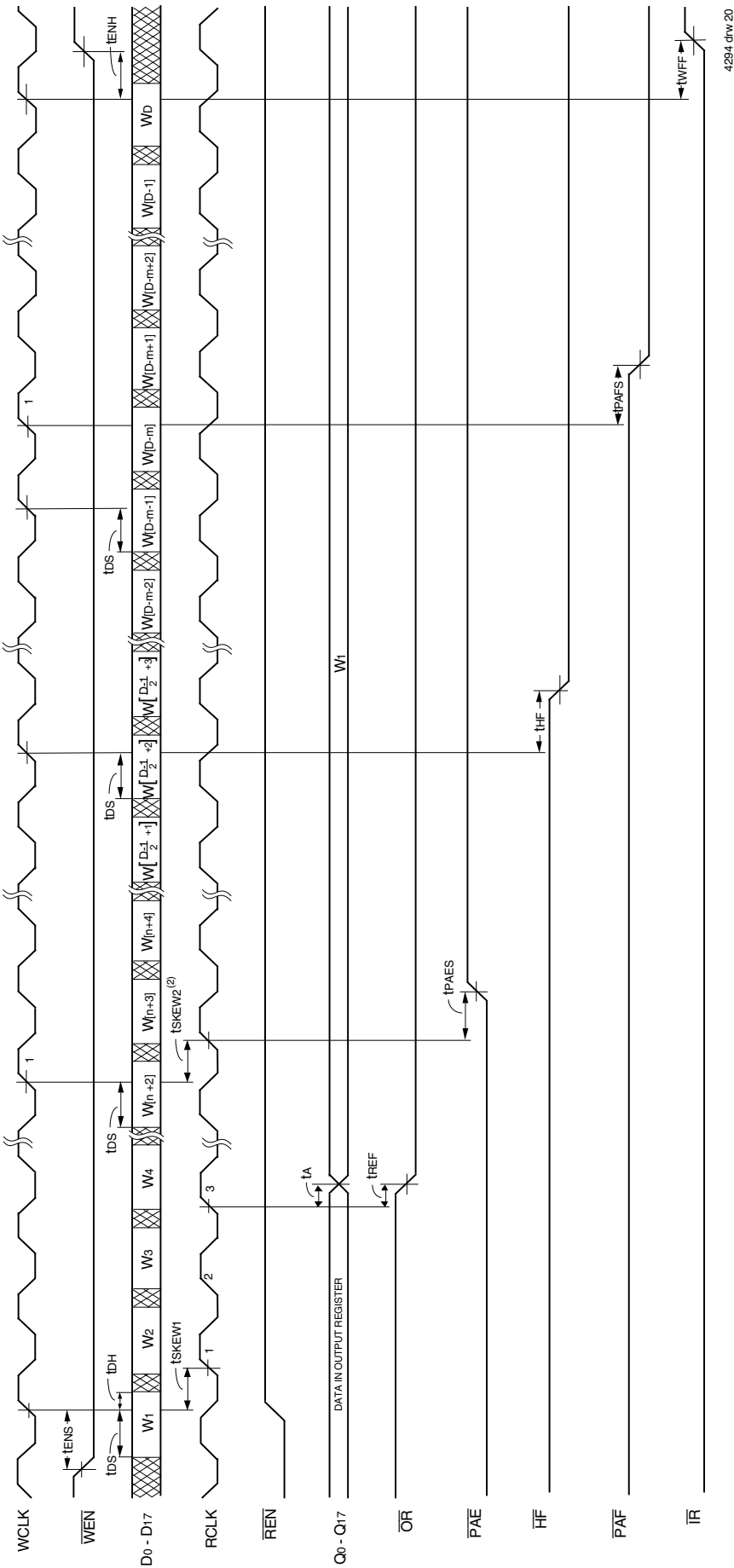

4294 drw.20

- NOTES:**
1.  $t_{SKEW1}$  is the minimum time between a rising WCLK edge and a rising RCLK edge for  $\overline{OR}$  to go LOW after two RCLK cycles plus  $t_{REF}$ . If the time between the rising edge of WCLK and the rising edge of RCLK is less than  $t_{SKEW1}$ , then the  $\overline{OR}$  deassertion may be delayed one extra RCLK cycle.
  2.  $t_{SKEW2}$  is the minimum time between a rising WCLK edge and a rising RCLK edge for  $\overline{PAE}$  to go HIGH during the current clock cycle. If the time between the rising edge of WCLK and the rising edge of RCLK is less than  $t_{SKEW2}$ , then the  $\overline{PAE}$  deassertion may be delayed one extra RCLK cycle.
  3.  $\overline{LD} = \text{HIGH}, \overline{OE} = \text{LOW}$
  4.  $n = \overline{PAE}$  offset,  $m = \overline{PAF}$  offset,  $D =$  maximum FIFO depth = 257 words for the IDT72V205, 513 words for the IDT72V215, 1,025 words for the IDT72V225, 2,049 words for the IDT72V235 and 4,097 words for the IDT72V245.
  5. Select this mode by setting  $(\overline{FL}, \overline{RXI}, \overline{WXI}) = (1,0,1)$  during Reset.

Figure 20. Write Timing with Synchronous Programmable Flags (FWFT Mode)

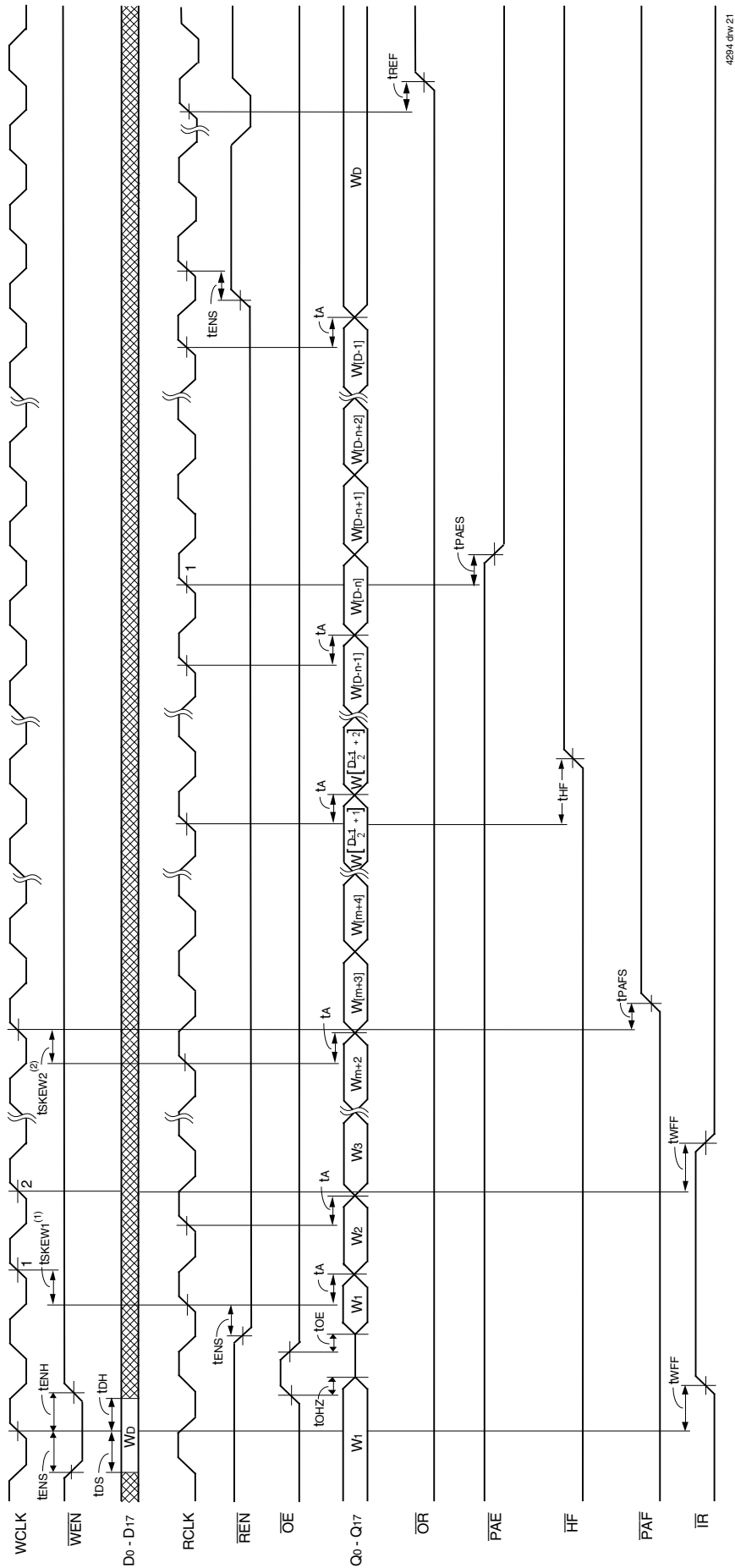

4294.drw/21

**NOTES:**

1. tSKEW1 is the minimum time between a rising RCLK edge and a rising WCLK edge to guarantee that  $\overline{IR}$  will go LOW after one WCLK plus tWFF. If the time between the rising edge of RCLK and the rising edge of WCLK is less than tSKEW1, then the  $\overline{IR}$  assertion may be delayed an extra WCLK cycle.
2. tSKEW2 is the minimum time between a rising RCLK edge and a rising WCLK edge for  $\overline{PAF}$  to go HIGH during the current clock cycle. If the time between the rising edge of RCLK and the rising edge of WCLK is less than tSKEW2, then the  $\overline{PAF}$  deassertion time may be delayed an extra WCLK cycle.
3.  $\overline{LD}$  = HIGH
4. n = PAE offset, m =  $\overline{PAF}$  offset, D = maximum FIFO depth = 257 words for the IDT72V205, 513 words for the IDT72V215, 1,025 words for the IDT72V225, 2,049 words for IDT72V235 and 4,097 words for IDT72V245.
5. Select this mode by setting (FL, RXI, WXI) = (1,0,1) during Reset.

Figure 21. Read Timing with Synchronous Programmable Flags (FWFT Mode)

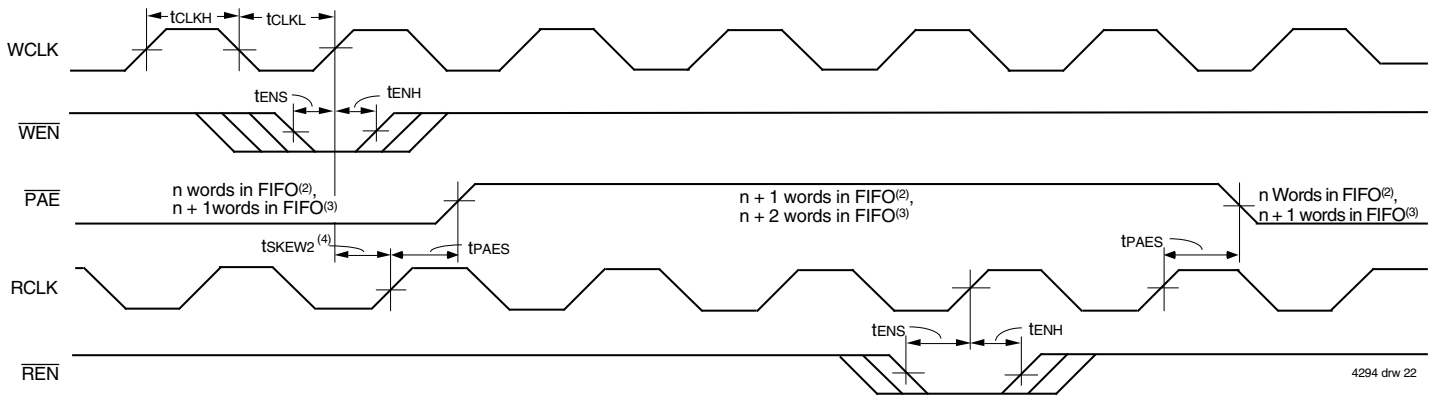

**NOTES:**

1.  $n = \overline{PAE}$  offset.
2. For IDT Standard Mode.
3. For FWFT Mode.
4.  $t_{SKEW2}$  is the minimum time between a rising WCLK edge and a rising RCLK edge for  $\overline{PAE}$  to go HIGH during the current clock cycle. If the time between the rising edge of WCLK and the rising edge of RCLK is less than  $t_{SKEW2}$ , then the  $\overline{PAE}$  deassertion may be delayed one extra RCLK cycle.
5.  $\overline{PAE}$  is asserted and updated on the rising edge of RCLK only.
6. Select this mode by setting  $(\overline{FL}, \overline{RXI}, \overline{WXI}) = (1,0,0), (1,0,1),$  or  $(1,1,0)$  during Reset.

**Figure 22. Synchronous Programmable Almost-Empty Flag Timing (IDT Standard and FWFT Modes)**

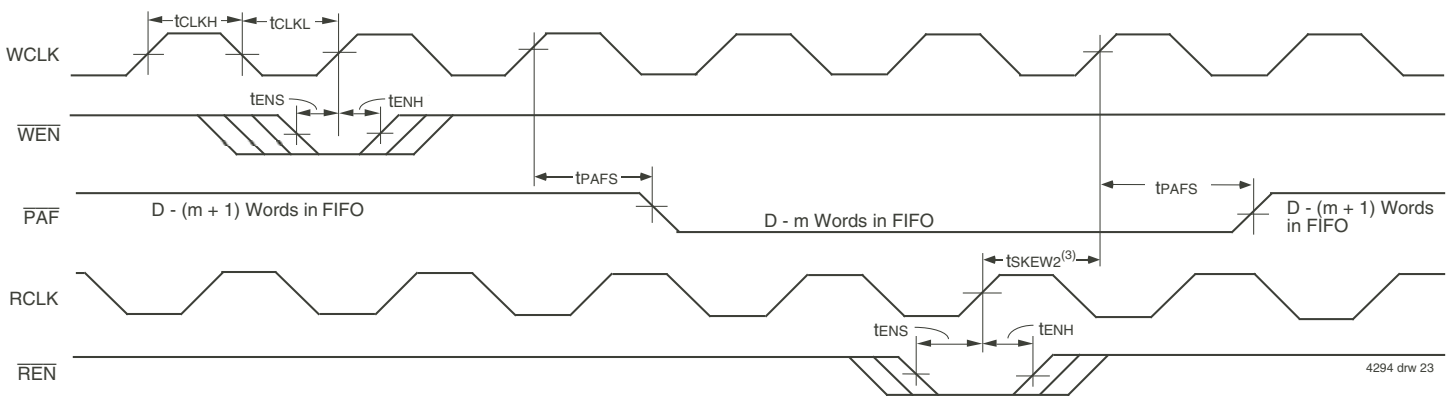

**NOTES:**

1.  $m = \overline{PAF}$  offset.
2.  $D =$  maximum FIFO Depth.  
 In IDT Standard Mode:  $D = 256$  for the IDT72V205, 512 for the IDT72V215, 1,024 for the IDT72V225, 2,048 for the IDT72V235 and 4,096 for the IDT72V245.  
 In FWFT Mode:  $D = 257$  for the IDT72V205, 513 for the IDT72V215, 1,025 for the IDT72V225, 2,049 for the IDT72V235 and 4,097 for the IDT72V245.
3.  $t_{SKEW2}$  is the minimum time between a rising RCLK edge and a rising WCLK edge for  $\overline{PAF}$  to go HIGH during the current clock cycle. If the time between the rising edge of RCLK and the rising edge of WCLK is less than  $t_{SKEW2}$ , then the  $\overline{PAF}$  deassertion time may be delayed an extra WCLK cycle.
4.  $\overline{PAF}$  is asserted and updated on the rising edge of WCLK only.
5. Select this mode by setting  $(\overline{FL}, \overline{RXI}, \overline{WXI}) = (1,0,0), (1,0,1),$  or  $(1,1,0)$  during Reset.

**Figure 23. Synchronous Programmable Almost-Full Flag Timing (IDT Standard and FWFT Modes)**

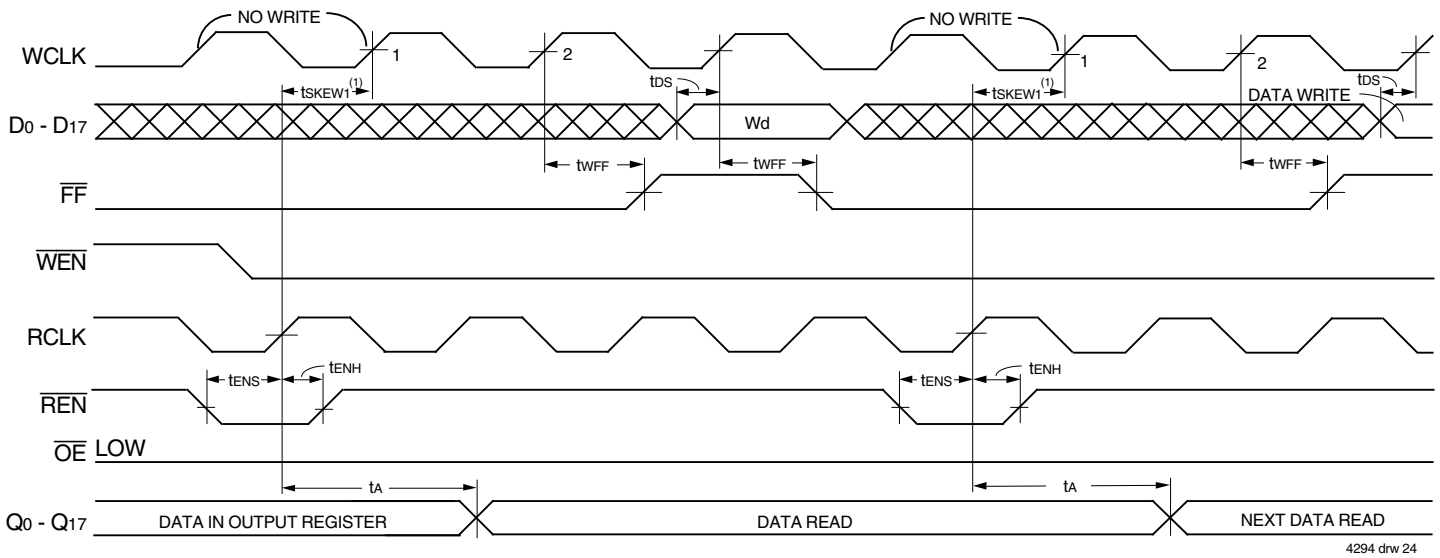

NOTES:

1. tsKEW1 is the minimum time between a rising RCLK edge and a rising WCLK edge to guarantee that FF will go HIGH after one WCLK cycle plus twFF. If the time between the rising edge of RCLK and the rising edge of WCLK is less than tsKEW1, then the FF deassertion time may be delayed an extra WCLK cycle.
2. LD = HIGH.
3. Select this mode by setting (FL, RXI, WXI) = (0,1,0) or (1,1,0) during Reset.

Figure 24. Double Register-Buffered Full Flag Timing (IDT Standard Mode)

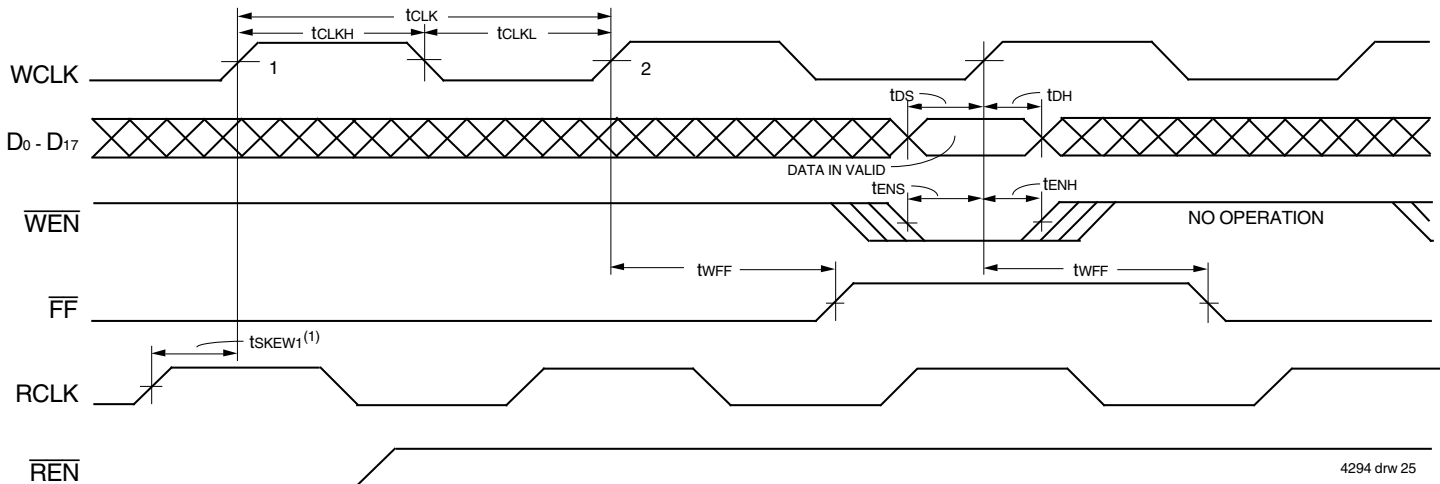

NOTES:

1. tsKEW1 is the minimum time between a rising RCLK edge and a rising WCLK edge to guarantee that FF will go HIGH after one WCLK cycle plus trFF. If the time between the rising edge of RCLK and the rising edge of WCLK is less than tsKEW1, then the FF deassertion may be delayed an extra WCLK cycle.
2. LD = HIGH.
3. Select this mode by setting (FL, RXI, WXI) = (0,1,0) or (1,1,0) during Reset.

Figure 25. Write Cycle Timing with Double Register-Buffered FF (IDT Standard Mode)



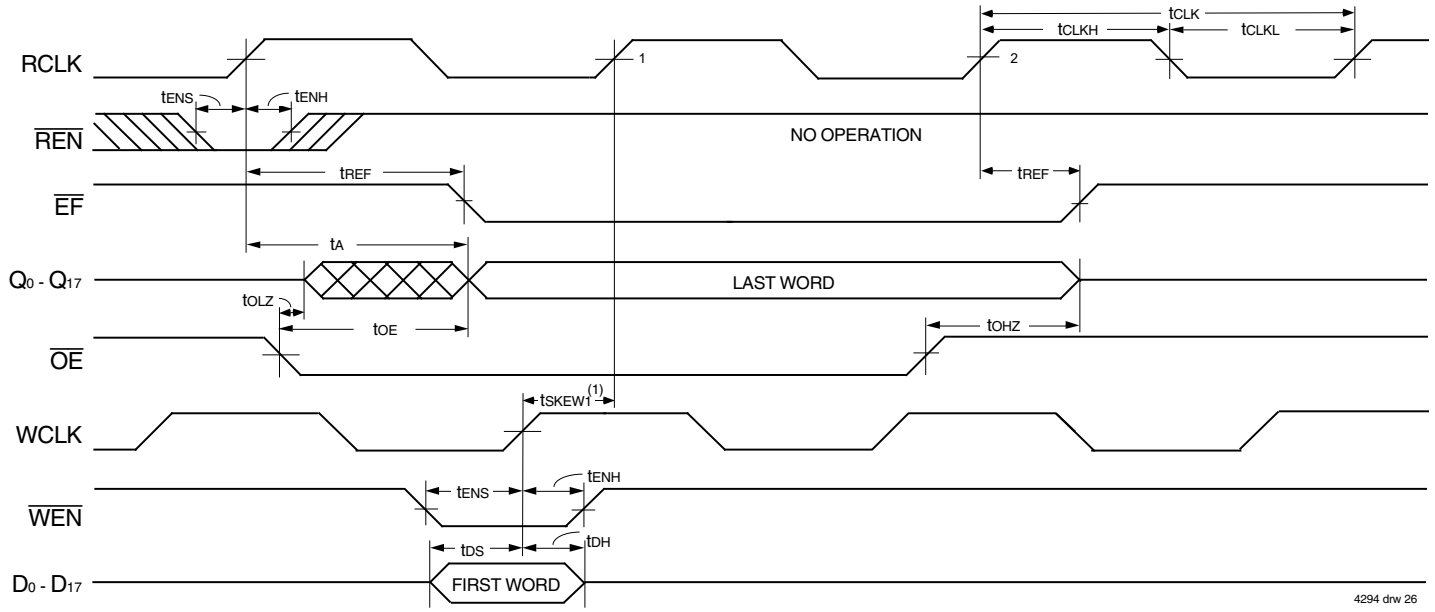

NOTES:

1.  $t_{SKEW1}$  is the minimum time between a rising WCLK edge and a rising RCLK edge to guarantee that  $\overline{EF}$  will go HIGH after one RCLK cycle plus  $t_{REF}$ . If the time between the rising edge of WCLK and the rising edge of RCLK is less than  $t_{SKEW1}$ , then the  $\overline{EF}$  deassertion may be delayed an extra RCLK cycle.
2.  $\overline{LD} = \text{HIGH}$
3. Select this mode by setting  $(\overline{FL}, \overline{RXI}, \overline{WXI}) = (0,1,0)$  or  $(1,1,0)$  during Reset.

Figure 26. Read Cycle Timing with Double Register-Buffered  $\overline{EF}$  (IDT Standard Timing)

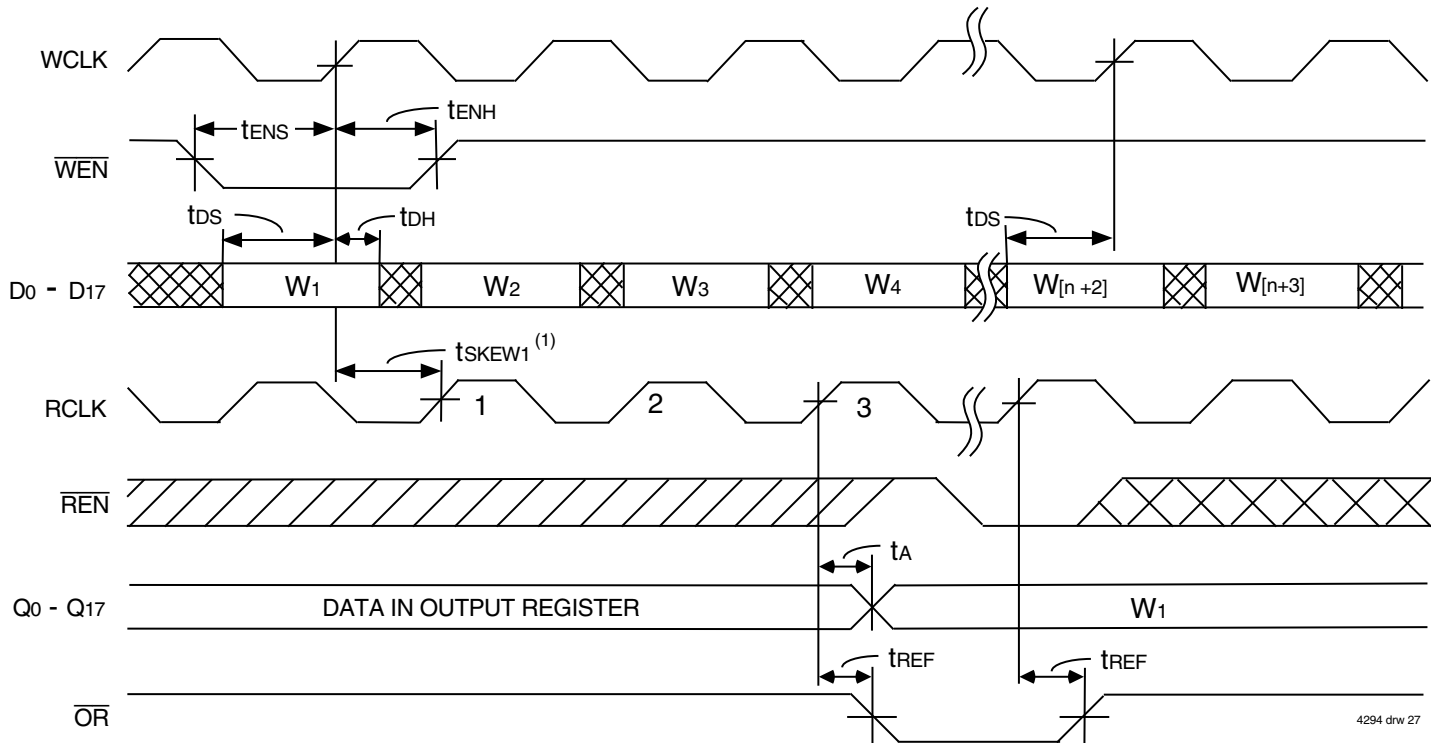

NOTES:

1.  $t_{SKEW1}$  is the minimum time between a rising WCLK edge and a rising RCLK edge for  $\overline{OR}$  to go HIGH during the current cycle. If the time between the rising edge of WCLK and the rising edge of RCLK is less than  $t_{SKEW1}$ , then the  $\overline{OR}$  deassertion may be delayed one extra RCLK cycle.
2.  $\overline{LD} = \text{HIGH}, \overline{OE} = \text{LOW}$
3. Select this mode by setting  $(\overline{FL}, \overline{RXI}, \overline{WXI}) = (0,0,1)$  or  $(1,0,1)$  during Reset.

Figure 27.  $\overline{OR}$  Flag Timing and First Word Fall Through when FIFO is Empty (FWFT mode)

## OPERATING CONFIGURATIONS

### SINGLE DEVICE CONFIGURATION

A single IDT72V205/72V215/72V225/72V235/72V245 may be used when the application requirements are for 256/512/1,024/2,048/4,096 words or less.

These FIFOs are in a single Device Configuration when the First Load ( $\overline{FL}$ ), Write Expansion In ( $\overline{WXI}$ ) and Read Expansion In ( $\overline{RXI}$ ) control inputs are configured as ( $\overline{FL}$ ,  $\overline{RXI}$ ,  $\overline{WXI}$ ) = (0,0,0), (0,0,1), (0,1,0), (1,0,0), (1,0,1) or (1,1,0) during reset (Figure 28).

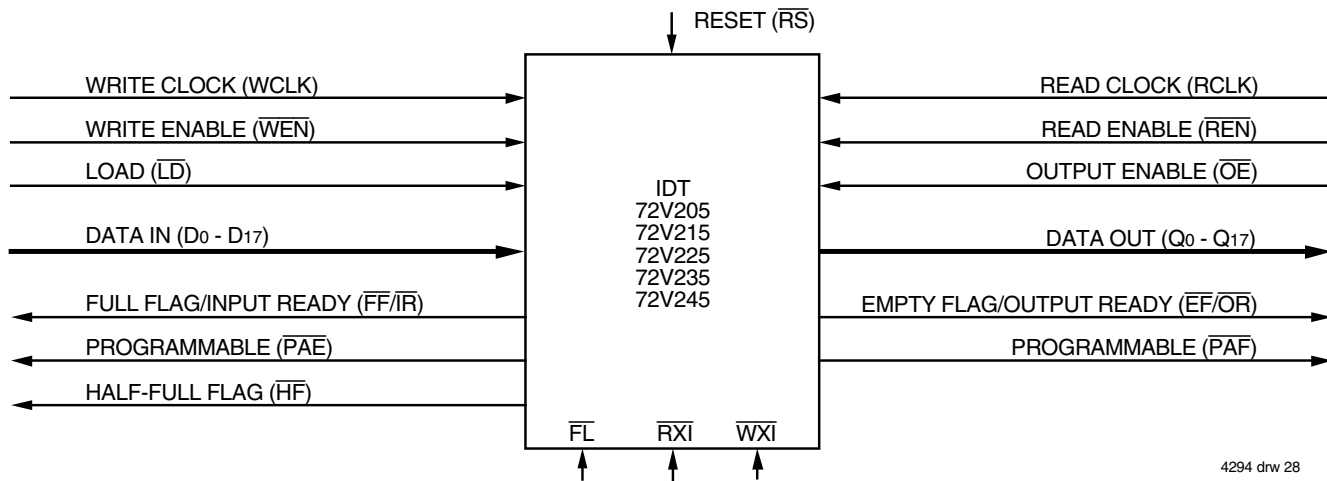

4294 drw 28

Figure 28. Block Diagram of Single 256 x 18, 512 x 18, 1,024 x 18, 2,048 x 18, 4,096 x 18 Synchronous FIFO

### WIDTH EXPANSION CONFIGURATION

Word width may be increased simply by connecting together the control signals of multiple devices. Status flags can be detected from any one device. The exceptions are the Empty Flag/Output Ready and Full Flag/Input Ready. Because of variations in skew between RCLK and WCLK, it is possible for flag assertion and deassertion to vary by one cycle between FIFOs. To avoid problems the user must create composite flags by gating the Empty Flags/Output Ready of every FIFO, and separately gating all Full Flags/Input Ready. Figure

29 demonstrates a 36-word width by using two IDT72V205/72V215/72V225/72V235/72V245s. Any word width can be attained by adding additional IDT72V205/72V215/72V225/72V235/72V245s. These FIFOs are in a single Device Configuration when the First Load ( $\overline{FL}$ ), Write Expansion In ( $\overline{WXI}$ ) and Read Expansion In ( $\overline{RXI}$ ) control inputs are configured as ( $\overline{FL}$ ,  $\overline{RXI}$ ,  $\overline{WXI}$ ) = (0,0,0), (0,0,1), (0,1,0), (1,0,0), (1,0,1) or (1,1,0) during reset (Figure 29). Please see the Application Note AN-83.

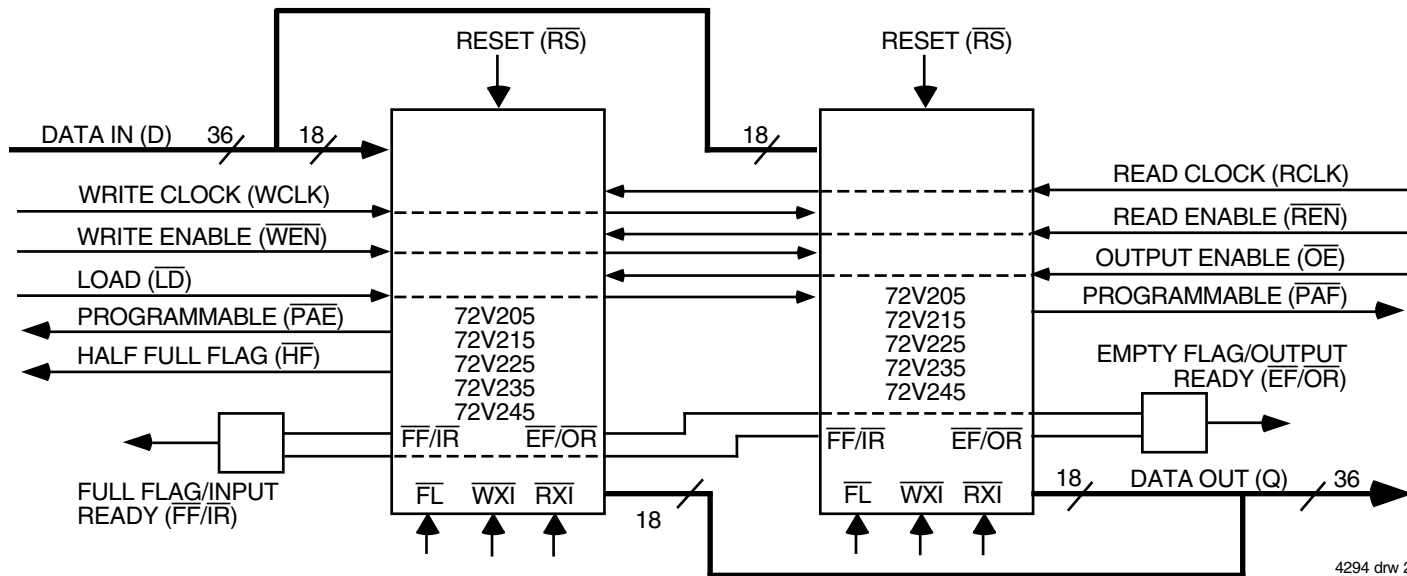

4294 drw 29

**NOTE:**

1. Do not connect any output control signals directly together.

Figure 29. Block Diagram of 256 x 36, 512 x 36, 1,024 x 36, 2,048 x 36, 4,096 x 36 Synchronous FIFO Memory Used in a Width Expansion Configuration

**DEPTH EXPANSION CONFIGURATION — DAISY CHAIN TECHNIQUE (WITH PROGRAMMABLE FLAGS)**

These devices can easily be adapted to applications requiring more than 256/512/1,024/2,048/4,096 words of buffering. Figure 30 shows Depth Expansion using three IDT72V205/72V215/72V225/72V235/72V245s. Maximum depth is limited only by signal loading.

Follow these steps:

1. The first device must be designated by grounding the First Load ( $\overline{FL}$ ) control input.
2. All other devices must have  $\overline{FL}$  in the HIGH state.
3. The Write Expansion Out ( $\overline{WXO}$ ) pin of each device must be tied to the Write Expansion In ( $\overline{WXI}$ ) pin of the next device. See Figure 30.

4. The Read Expansion Out ( $\overline{RXO}$ ) pin of each device must be tied to the Read Expansion In ( $\overline{RXI}$ ) pin of the next device. See Figure 30.
5. All Load ( $\overline{LD}$ ) pins are tied together.
6. The Half-Full Flag ( $\overline{HF}$ ) is not available in this Depth Expansion Configuration.
7.  $\overline{EF}$ ,  $\overline{FF}$ ,  $\overline{PAE}$ , and  $\overline{PAF}$  are created with composite flags by ORing together every respective flags for monitoring. The composite  $\overline{PAE}$  and  $\overline{PAF}$  flags are not precise.
8. In Daisy Chain mode, the flag outputs are single register-buffered and the partial flags are in asynchronous timing mode.

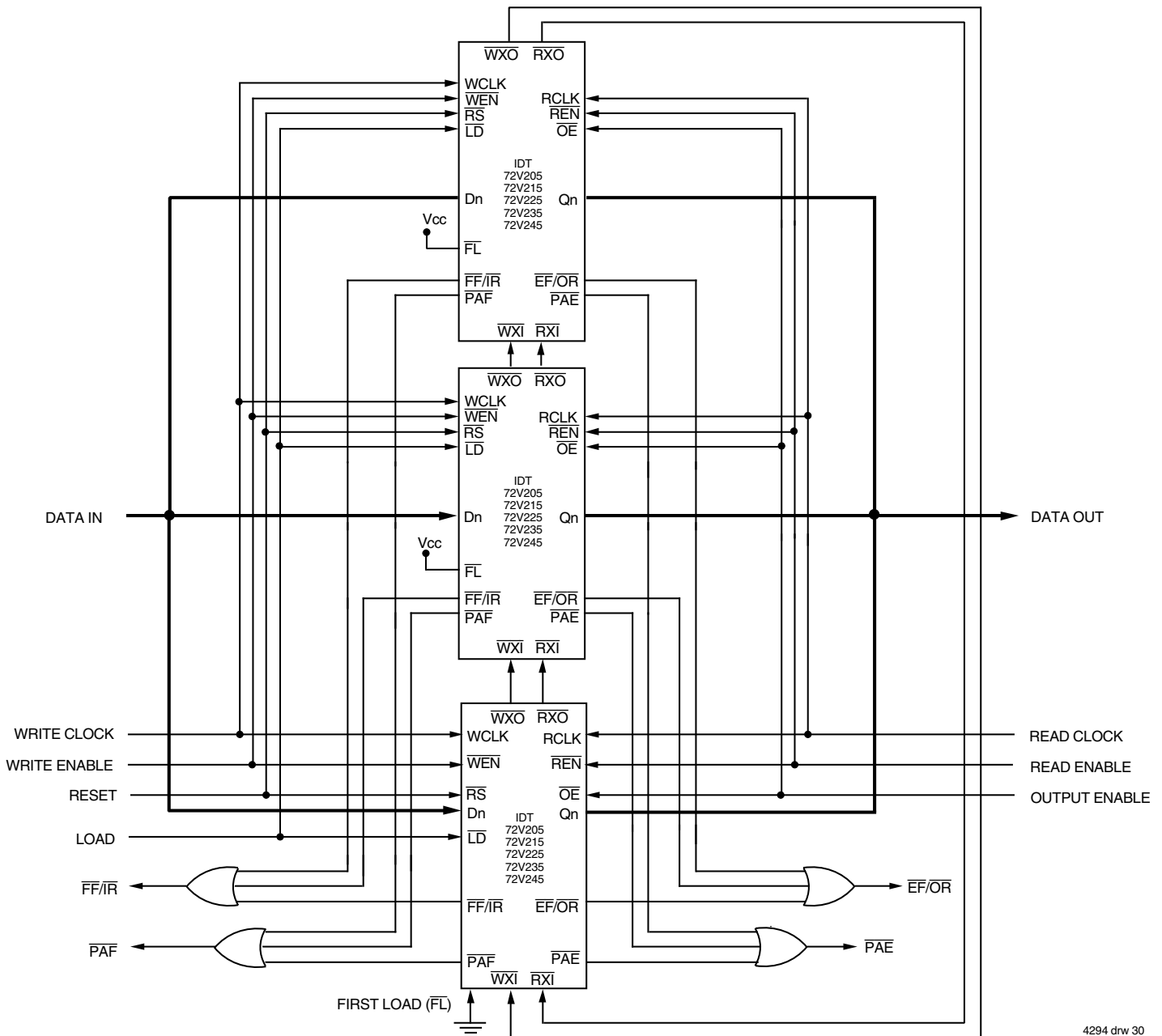

4294 drw 30

Figure 30. Block Diagram of 768 x 18, 1,536 x 18, 3,072 x 18, 6,144 x 18, 12,288 x 18 Synchronous FIFO Memory With Programmable Flags used in Depth Expansion Configuration

**DEPTH EXPANSION CONFIGURATION (FWFT MODE)**

In FWFT mode, the FIFOs can be connected in series (the data outputs of one FIFO connected to the data inputs of the next) with no external logic necessary. The resulting configuration provides a total depth equivalent to the sum of the depths associated with each single FIFO. Figure 31 shows a depth expansion using two IDT72V205/72V215/72V225/72V235/72V245 devices.

Care should be taken to select FWFT mode during Master Reset for all FIFOs in the depth expansion configuration. The first word written to an empty configuration will pass from one FIFO to the next (“ripple down”) until it finally appears at the outputs of the last FIFO in the chain—no read operation is necessary but the RCLK of each FIFO must be free-running. Each time the data word appears at the outputs of one FIFO, that device’s  $\overline{OR}$  line goes LOW, enabling a write to the next FIFO in line.

For an empty expansion configuration, the amount of time it takes for  $\overline{OR}$  of the last FIFO in the chain to go LOW (i.e. valid data to appear on the last FIFO’s outputs) after a word has been written to the first FIFO is the sum of the delays for each individual FIFO:

$$(N - 1) * (4 * \text{transfer clock}) + 3 * \text{TRCLK}$$

where N is the number of FIFOs in the expansion and TRCLK is the RCLK period. Note that extra cycles should be added for the possibility that the tsKEW1

specification is not met between WCLK and transfer clock, or RCLK and transfer clock, for the  $\overline{OR}$  flag.

The “ripple down” delay is only noticeable for the first word written to an empty depth expansion configuration. There will be no delay evident for subsequent words written to the configuration.

The first free location created by reading from a full depth expansion configuration will “bubble up” from the last FIFO to the previous one until it finally moves into the first FIFO of the chain. Each time a free location is created in one FIFO of the chain, that FIFO’s  $\overline{IR}$  line goes LOW, enabling the preceding FIFO to write a word to fill it.

For a full expansion configuration, the amount of time it takes for  $\overline{IR}$  of the first FIFO in the chain to go LOW after a word has been read from the last FIFO is the sum of the delays for each individual FIFO:

$$(N - 1) * (3 * \text{transfer clock}) + 2 \text{ TwCLK}$$

where N is the number of FIFOs in the expansion and TwCLK is the WCLK period. Note that extra cycles should be added for the possibility that the tsKEW1 specification is not met between RCLK and transfer clock, or WCLK and transfer clock, for the  $\overline{IR}$  flag.

The Transfer Clock line should be tied to either WCLK or RCLK, whichever is faster. Both these actions result in data moving, as quickly as possible, to the end of the chain and free locations to the beginning of the chain.

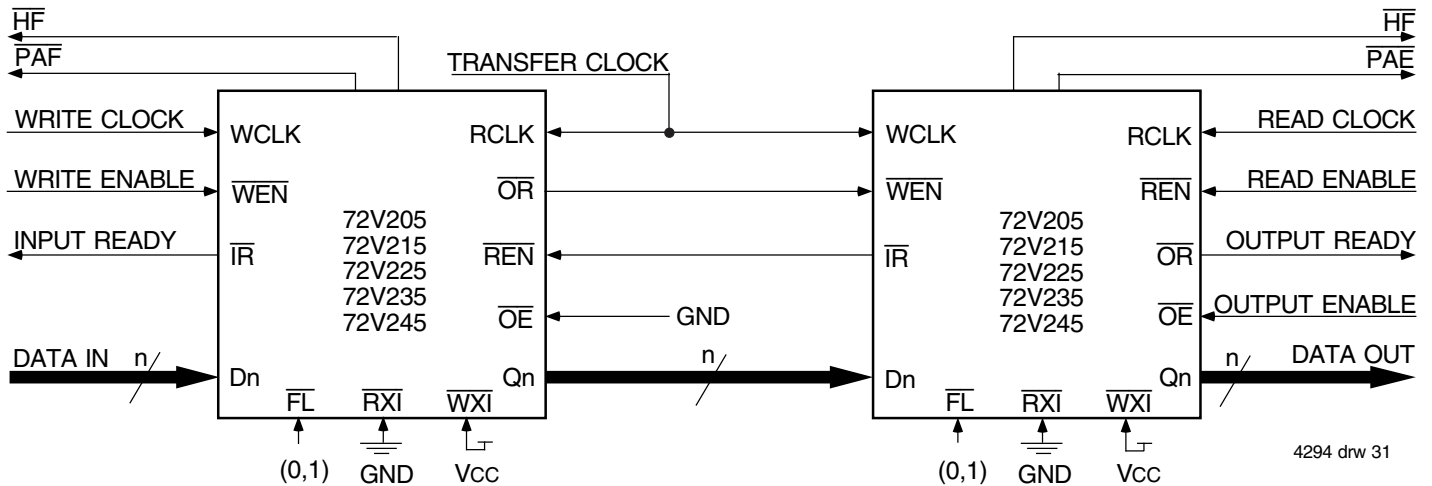
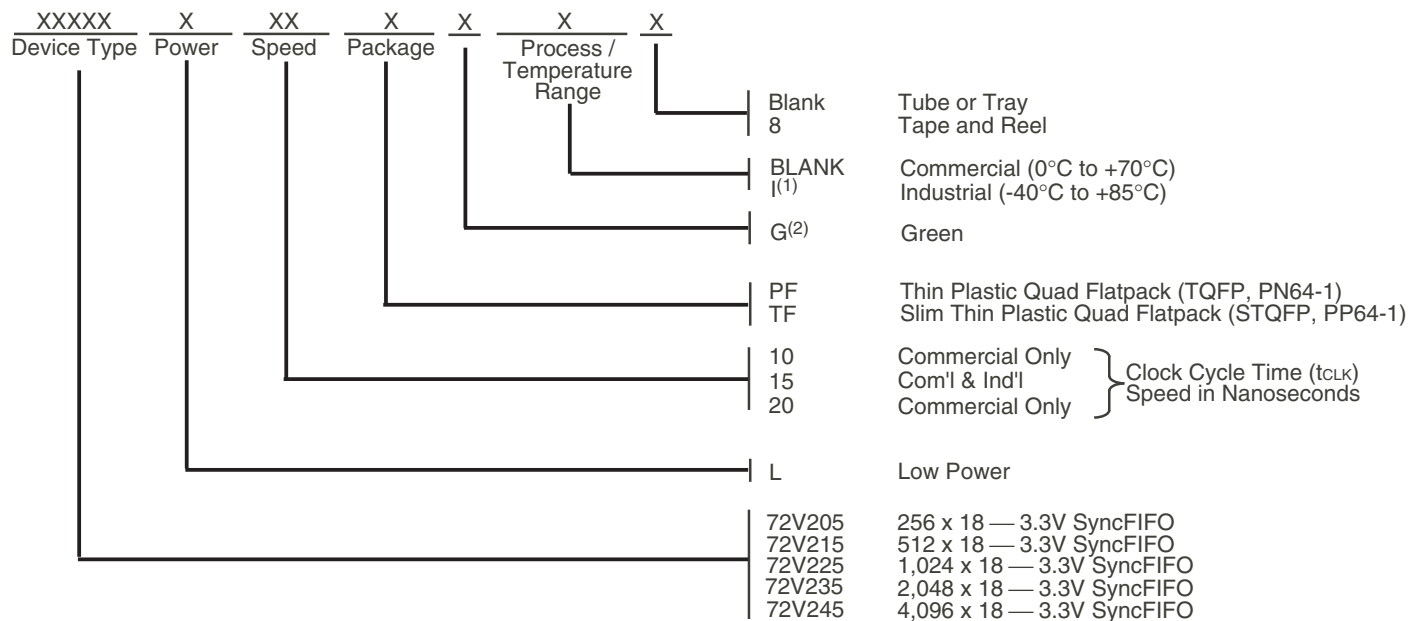

Figure 31. Block Diagram of 512 x 18, 1,024 x 18, 2,048 x 18, 4,096 x 18, 8,192 x 18 Synchronous FIFO Memory With Programmable Flags used in Depth Expansion Configuration

# ORDERING INFORMATION



4294 drw 32

## NOTES:

1. Industrial temperature range product for the 15ns speed grade is available as a standard device. All other speed grades are available by special order.
2. Green parts are available. For specific speeds and packages contact your sales office.

**LEAD FINISH (SNPB) PARTS ARE IN EOL PROCESS. PRODUCT DISCONTINUATION NOTICE - PDN# SP-17-02**

## DATASHEET DOCUMENT HISTORY

05/02/2001	pgs. 4, 5 and 25.
01/11/2002	pg. 4.
02/01/2002	pg. 4.
02/22/2006	pgs. 1 and 25.
10/22/2008	pg. 25.
03/21/2013	pg. 2 and 25.
03/19/2018	Product Discontinuation Notice - PDN# SP-17-02 Last time buy expires June 15, 2018.

## IMPORTANT NOTICE AND DISCLAIMER

RENESAS ELECTRONICS CORPORATION AND ITS SUBSIDIARIES (“RENESAS”) PROVIDES TECHNICAL SPECIFICATIONS AND RELIABILITY DATA (INCLUDING DATASHEETS), DESIGN RESOURCES (INCLUDING REFERENCE DESIGNS), APPLICATION OR OTHER DESIGN ADVICE, WEB TOOLS, SAFETY INFORMATION, AND OTHER RESOURCES “AS IS” AND WITH ALL FAULTS, AND DISCLAIMS ALL WARRANTIES, EXPRESS OR IMPLIED, INCLUDING, WITHOUT LIMITATION, ANY IMPLIED WARRANTIES OF MERCHANTABILITY, FITNESS FOR A PARTICULAR PURPOSE, OR NON-INFRINGEMENT OF THIRD-PARTY INTELLECTUAL PROPERTY RIGHTS.

These resources are intended for developers who are designing with Renesas products. You are solely responsible for (1) selecting the appropriate products for your application, (2) designing, validating, and testing your application, and (3) ensuring your application meets applicable standards, and any other safety, security, or other requirements. These resources are subject to change without notice. Renesas grants you permission to use these resources only to develop an application that uses Renesas products. Other reproduction or use of these resources is strictly prohibited. No license is granted to any other Renesas intellectual property or to any third-party intellectual property. Renesas disclaims responsibility for, and you will fully indemnify Renesas and its representatives against, any claims, damages, costs, losses, or liabilities arising from your use of these resources. Renesas' products are provided only subject to Renesas' Terms and Conditions of Sale or other applicable terms agreed to in writing. No use of any Renesas resources expands or otherwise alters any applicable warranties or warranty disclaimers for these products.

(Disclaimer Rev.1.01)

### Corporate Headquarters

TOYOSU FORESIA, 3-2-24 Toyosu,  
Koto-ku, Tokyo 135-0061, Japan  
[www.renesas.com](http://www.renesas.com)

### Trademarks

Renesas and the Renesas logo are trademarks of Renesas Electronics Corporation. All trademarks and registered trademarks are the property of their respective owners.

### Contact Information

For further information on a product, technology, the most up-to-date version of a document, or your nearest sales office, please visit [www.renesas.com/contact-us/](http://www.renesas.com/contact-us/).